

The Engineering Staff of
TEXAS INSTRUMENTS INCORPORATED
Semiconductor Group



The Voltage Regulator Handbook

ARROW ELECTRONICS, INC.
ELECTRONICS DISTRIBUTION DIVISION
96D COMMERCE WAY
WOBURN, MASSACHUSETTS 01801
617/933/8130



TEXAS INSTRUMENTS
INCORPORATED

The Voltage Regulator Handbook

Compiled by
John D. Spencer
Dale E. Pippenger



TEXAS INSTRUMENTS
INCORPORATED

P.O. Box 5012 Dallas, Texas 75222

IMPORTANT NOTICES

Texas Instruments reserves the right to make changes at any time in order to improve design and to supply the best product possible.

TI cannot assume any responsibility for any circuits shown or represent that they are free from patent infringement.

ISBN 0-89512-101-8
Library of Congress No. 77-87869

Copyright © 1977
Texas Instruments Incorporated

Table of Contents

	<i>Page</i>
REGULATOR ALPHANUMERIC INDEX	v
INTRODUCTION	vii
Part 1	
1 VOLTAGE REGULATORS.	1
1.1 Basic Regulator	1
1.2 Regulator Classifications	3
2 MAJOR ERROR CONTRIBUTORS	7
2.1 Reference.	7
2.2 Sampling Element	11
2.3 Comparator	12
3 REGULATOR DESIGN CONSIDERATIONS.	17
3.1 Positive Versus Negative Regulators	17
3.2 Fixed Versus Adjustable Regulators.	18
3.3 Dual-Tracking Regulators.	19
3.4 Series Regulators	19
3.5 Floating Regulator	20
3.6 Shunt Regulator	22
3.7 Switching Regulator.	23
4 REGULATOR SAFE OPERATING AREA	29
4.1 Regulator Safe Operating Area.	29
4.2 External Pass Transistor	31
4.3 Safe Operating Protection Circuits	32
5 THERMAL CONSIDERATIONS.	39
5.1 Thermal Equation	39
5.2 Heat-Sink Design	46

Table of Contents (Continued)

		<i>Page</i>
6	LAYOUT GUIDELINES	59
6.1	General	59
6.2	Current Paths	59
6.3	Thermal Profile	61
7	INPUT FILTER DESIGN	63
7.1	Transformer/Rectifier Configuration	63
7.2	Capacitor Input Filter	65
7.3	Design Procedure	70

Part 2

	GLOSSARY	79
	REGULATOR SELECTION GUIDE	82
	REGULATOR ALPHANUMERIC INDEX	84
	INDEX TO APPLICATIONS CIRCUITS	85
	INDIVIDUAL DATA SHEETS	
	LM104, LM204, LM304 Negative-Voltage Regulators	87
	LM105, LM205, LM305, LM305A, LM376 Positive-Voltage Regulators	91
	LM109, LM209, LM309 5-Volt Regulators	95
	LM117, LM217, LM317 3-Terminal Adjustable Regulators	99
	Series LM340 Positive-Voltage Regulators	105
	SG1524, SG2524, SG3524 Regulating Pulse Width Modulators	113
	TL430 Adjustable Shunt Regulator	125
	TL431 Adjustable Precision Shunt Regulator	129
	TL432 Timer/Regulator/Comparator Building Blocks	133
	TL494 Pulse-Width-Modulation Control Circuit	135
	TL497 Switching Voltage Regulator	137
	TL7805A 3-Percent 5-Volt Regulator	141
	uA723 Precision Voltage Regulator	143
	Series uA7800 Positive-Voltage Regulators	149
	Series uA78L00 Positive-Voltage Regulators	157
	Series uA78M00 Positive-Voltage Regulators	163
	Series uA7900 Negative-Voltage Regulators	173
	Series uA79M00 Negative-Voltage Regulators	179
	ORDERING INSTRUCTIONS AND MECHANICAL DATA	189

Regulator Alphanumeric Index

	PAGE		PAGE
LM104	87	uA78L05	157
LM105	91	uA78L05A	157
LM109	95	uA78L06	157
LM117	99	uA78L06A	157
LM204	87	uA78L08	157
LM205	91	uA78L08A	157
LM209	95	uA78L09	157
LM217	99	uA78L09A	157
LM304	87	uA78L10	157
LM305	91	uA78L10A	157
LM305A	91	uA78L12	157
LM309	95	uA78L12A	157
LM317	99	uA78L15	157
LM340	105	uA78L15A	157
LM376	91	uA78M05	163
SG1524	113	uA78M06	163
SG2524	113	uA78M08	163
SG3524	113	uA78M12	163
TL430	125	uA78M15	163
TL431	129	uA78M20	163
TL432	133	uA78M22	163
TL494	135	uA78M24	163
TL497	137	uA7905	173
TL7805A	141	uA7906	173
uA723	143	uA7908	173
uA7805	149	uA7912	173
uA7806	149	uA7915	173
uA7808	149	uA7918	173
uA7810	149	uA7924	173
uA7812	149	uA7952	173
uA7815	149	uA79M05	179
uA7818	149	uA79M06	179
uA7822	149	uA79M08	179
uA7824	149	uA79M12	179
uA7885	149	uA79M15	179
uA78L02	157	uA79M20	179
uA78L02A	157	uA79M24	179

INTRODUCTION

Voltage regulation is a basic function in the majority of today's electronic systems yet it often takes a back seat in system development. With continual advancement of semiconductor technology and the advent of the microprocessor, electronics are finding their way into an increasingly broadening field of specialized applications. Too often, a design finds itself stalled in the development of a power supply to complete the total system. This problem is being eased with the development of a new generation of monolithic integrated circuit regulators and discrete components which offer design simplification, improved reliability, and a reduction in system cost and size.

This handbook has been written to encompass the total power supply design and aid the engineer in the selection of regulator integrated circuits and associated components. In addition to basic power supply design theory, related topics such as external pass transistor considerations, input filter designs, voltage rectification techniques, and mounting and heat-sinking techniques are discussed. Complete data sheet information on all components and mechanical hardware are included.

Part 1

1

Voltage Regulators

1.1 BASIC REGULATOR

The purpose of every voltage regulator is to convert a given dc or ac input voltage into a specific stable dc output voltage and maintain that voltage over a wide range of load conditions. To accomplish this, the typical voltage regulator (Figure 1.1) consists of:

- 1) A reference element that provides a known stable level, (V_{REF}).
- 2) A sampling element to sample output voltage level.
- 3) A comparator element for comparing the output voltage sample to the reference and creating an error signal.
- 4) A control element to provide translation of the input voltage to the desired output level over varying load conditions as indicated by the error signal.

Even though regulation methods vary among the three basic regulators: (1) series, (2) shunt, (3) switching, these four basic functions exist in all regulator circuits.

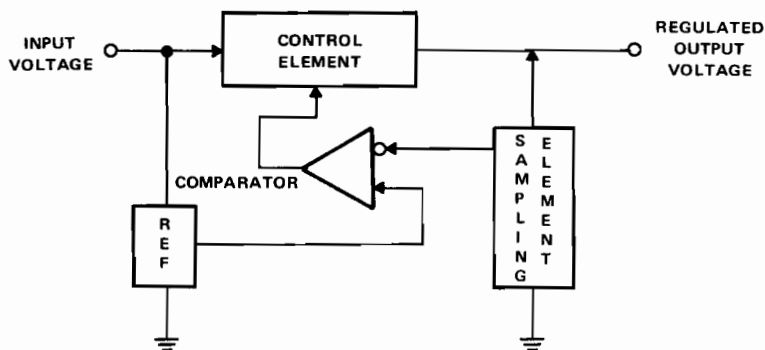

Figure 1.1. Basic Regulator Block Diagram

1.1.1 Reference Element

The reference element forms the foundation of all voltage regulators since output voltage is either equal to or a multiple of the reference. Variations in the reference voltage will be interpreted as output voltage errors by the comparator and cause the output voltage to change accordingly. For good regulation, the reference must be stable for all variations in supply voltages and junction temperatures. Various techniques commonly used in integrated circuit regulators are discussed in detail in the text outlining error considerations.

1.1.2 Sampling Element

The sampling element monitors output voltage and translates it into a level equal to the reference voltage for a desired output voltage. Variations in the output voltage then cause the feedback voltage to change to some value greater than or less than the reference voltage. This delta voltage is the error voltage that directs the regulator to respond appropriately to correct for the output voltage change experienced.

1.1.3 Comparator Element

The comparator element of an integrated circuit voltage regulator not only monitors the feedback voltage for comparison with the reference, but also provides gain for the detected error level. For this reason, the comparator element is also referred to as the error amplifier. The output of the comparator element, the amplified error signal, is then translated by the control circuit to return the output to a prescribed level.

1.1.4 Control Element

All of the previous elements discussed remain virtually unaltered regardless of the type of regulator of which they form a part. The control element varies widely depending on the type of regulator being designed. It is the control that determines the classification of the voltage regulator: series, shunt, or switching. Figure 1.2 shows representations of the basic control element configurations, each of which is discussed in detail. The control element contributes an insignificant amount of error to the regulator's performance since the sense element monitors the output voltage beyond the control element and compensates for its error contributions. The control element reflects directly on the regulator's performance characteristics in that it affects such parameters as minimum input-to-output voltage differential, circuit efficiency, and power dissipation.

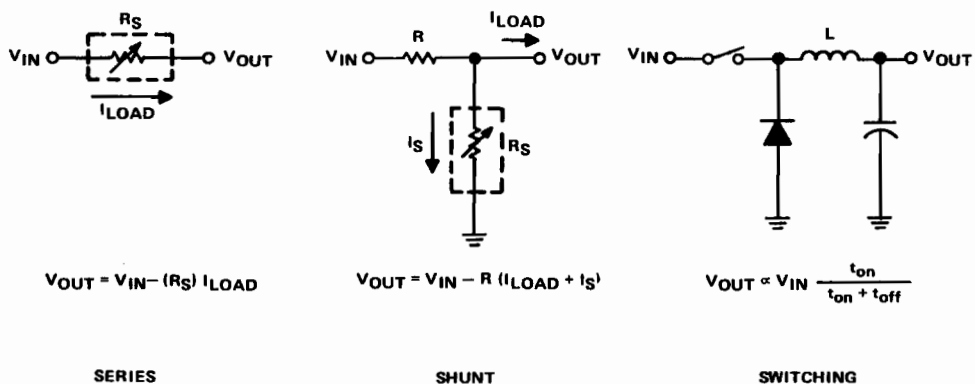

Figure 1.2. Control Element Configurations

1.2 REGULATOR CLASSIFICATIONS

1.2.1 Series Regulator

The series regulator derives its name from the control element it uses. The output voltage is regulated by modulating a series element, usually a transistor, that acts as a variable resistor. Changes in input voltage result in a change in the equivalent resistance of the series element. The product of this resistance and the load current create a changing differential voltage that compensates for a changing input voltage. The basic series regulator is illustrated in Figure 1.3.

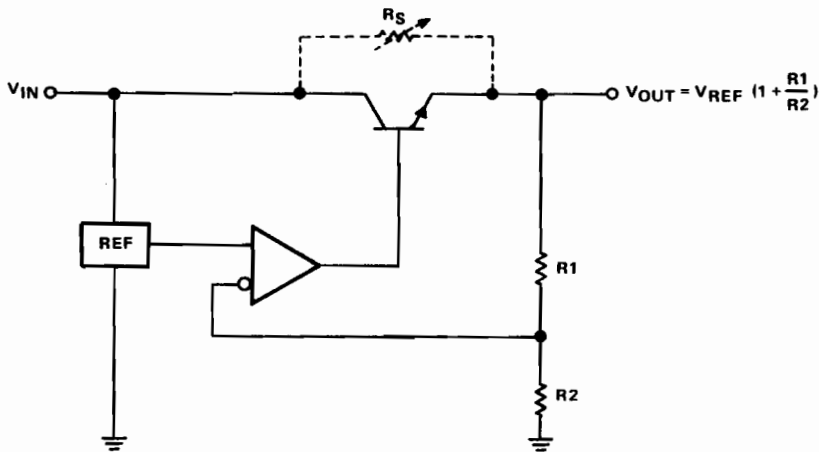

Figure 1.3. Basic Series Regulator

$$V_{OUT} = V_{IN} - V_{DIFF}$$

$$V_{DIFF} = I_{LOAD} R_S$$

$$V_{OUT} = V_{IN} - I_{LOAD} R_S$$

For a changing input voltage:

$$\Delta R_S = \frac{\Delta V_{IN}}{I_{LOAD}}$$

For a changing load current:

$$\Delta R_S = -\frac{\Delta I_{LOAD} R_S}{I_{LOAD} + \Delta I_{LOAD}}$$

Series regulators provide a simple inexpensive way to obtain a source of regulated voltage. In high-current applications, however, the voltage drop maintained across the pass element results in a substantial power loss.

1.2.2 Shunt Regulator

The shunt regulator employs a shunt element that varies its shunt current requirement to account for varying input voltages or changing load conditions. The basic shunt regulator is shown in Figure 1.4.

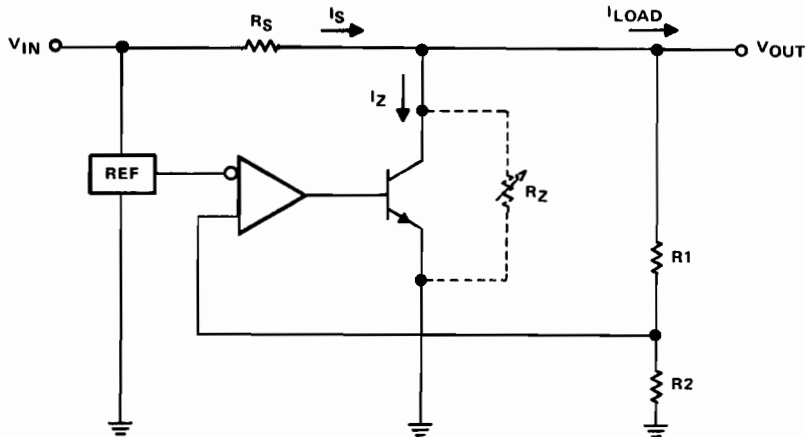

Figure 1.4. Basic Shunt Regulator

$$V_{OUT} = V_{IN} - I_S R_S$$

$$I_S = I_{LOAD} + I_Z$$

$$V_{OUT} = V_{IN} - R_S (I_{LOAD} + I_Z)$$

For a changing load current

$$\Delta I_Z = -\Delta I_{LOAD}$$

For a changing input voltage

$$\Delta I_Z = \frac{\Delta V_{IN}}{R}$$

$$\Delta I_Z = \frac{V_{OUT}}{\Delta R_Z}$$

Even though it is usually less efficient, a shunt regulator may prove to be the best choice for a specific application. The shunt regulator is less sensitive to input voltage transients, it does not reflect load current transients back to the source, and it is inherently short-circuit proof.

1.2.3 Switching Regulator

The switching regulator employs an active switch as its control element, which is used to chop the input voltage at a varying duty cycle¹ based on the regulator's load requirements. See Figure 1.5.

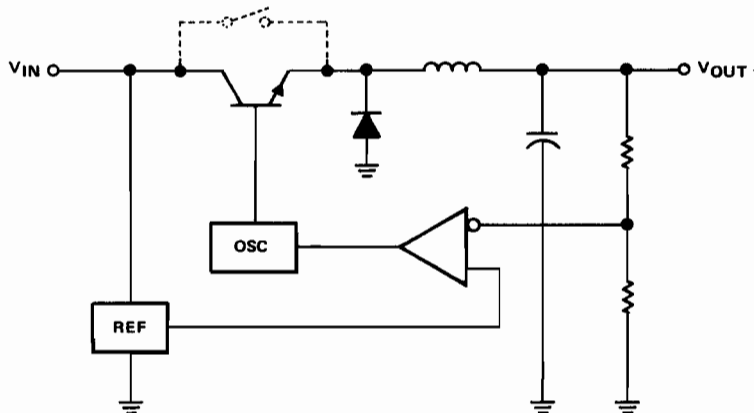

Figure 1.5. Basic Switching Regulator (Step-Down Configuration)

A filter, usually an LC filter, is then used to average the voltage seen at its input and deliver that voltage to the output load. Since the pass transistor is either on (saturated) or off, the power lost in the control element is minimal. For this reason the switching regulator becomes particularly attractive for applications involving large input-to-output differential voltages or high load-current requirements. In the past, switching voltage regulators were discrete designs but recent advancements in integrated circuit technology have resulted in several monolithic switching regulator circuits that contain all of the necessary elements to design step-up, step-down, or inverting voltage converters or mainframe power supplies.

1. The duty cycle may be varied by:
 - a. maintaining a constant on-time, varying the frequency
 - b. maintaining a constant off-time, varying the frequency
 - c. maintaining a constant frequency, varying the on/off times.

The performance of these techniques, their advantages, and disadvantages are discussed in Section 3.

2 Major Error Contributors

The ideal voltage regulator maintains a constant output voltage over varying input voltage, load, and temperature conditions. Realistically, however, these influences affect the regulator's output voltage. In addition, the regulator's internal inaccuracies affect the overall circuit performance. This section discusses the major contributors, their effects, and possible solutions to the problems they create.

2.1 REFERENCE

There are several techniques employed in integrated circuit voltage regulators. Each provides its particular level of performance and problems. The optimum reference depends on the regulator's requirements.

2.1.1 Zener Diode Reference

The zener diode reference, as shown in Figure 2.1, is the simplest technique. The zener voltage itself, V_Z , forms the reference voltage, V_{REF} . This technique is satisfactory for stable supply voltage applications but becomes unstable in unregulated supply voltage applications. The instability results from a changing zener current, I_Z , as the supply voltage varies. The changing zener current precipitates a change in the value of V_Z , the reference voltage. The zener reference model is shown in Figure 2.2.

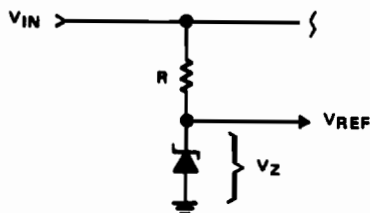

Figure 2.1. Basic Zener Reference

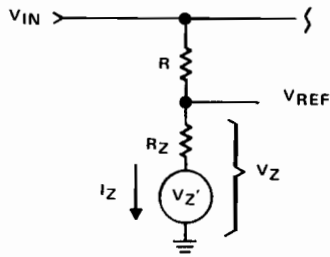

Figure 2.2. Zener Reference Model

$$V_{REF} = V_Z$$

$$V_Z = V_{Z'} + I_Z R_Z$$

$$I_Z = \frac{V_{IN} - V_{Z'}}{R + R_Z}$$

$$V_{REF} = V_{Z'} + R_Z \left(\frac{V_{IN} - V_{Z'}}{R + R_Z} \right)$$

V_{REF} is a function of V_{IN} .

2.1.2 Constant-Current Zener Reference

The zener reference can be refined by the addition of a constant-current source as its supply. Driving the zener diode with a constant current minimizes the effect of zener impedance on the overall stability of the zener reference. An example of this technique is shown in Figure 2.3. The reference voltage of this configuration is relatively independent of changes in supply voltage.

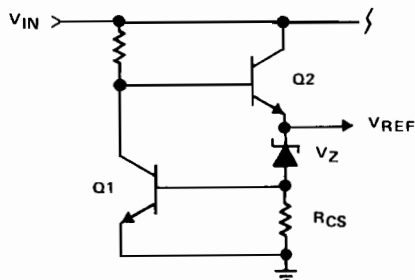

Figure 2.3. Constant-Current Zener Reference

$$V_{REF} = V_Z + V_{BE(Q1)}$$

$$I_Z = \frac{V_{BE(Q1)}}{R_{CS}}$$

V_{REF} is independent of V_{IN} .

In addition to superior supply voltage rejection, the circuit shown in Figure 2.3 yields improved temperature stability. The reference voltage V_{REF} is the sum of the zener voltage V_Z and the base-emitter voltage of Q1 $V_{BE(Q1)}$. A low temperature coefficient can be achieved by balancing the positive temperature coefficient of the zener with the negative temperature coefficient of the base-emitter junction of Q1. The only drawback of the constant-current zener reference is that it requires a supply voltage of 9 volts or more.

2.1.3 Band-Gap Reference

Another popular reference is the band-gap reference, which is developed from the highly predictable emitter-base voltage of integrated transistors. Basically, the reference voltage is derived from the energy-band-gap voltage of the semiconductor material, ($V_{go(\text{silicon})} = 1.204 \text{ V}$). The basic band-gap configuration is shown in Figure 2.4. The reference voltage V_{REF} in this case is:

$$V_{REF} = V_{BE(Q3)} + I_2 R_2$$

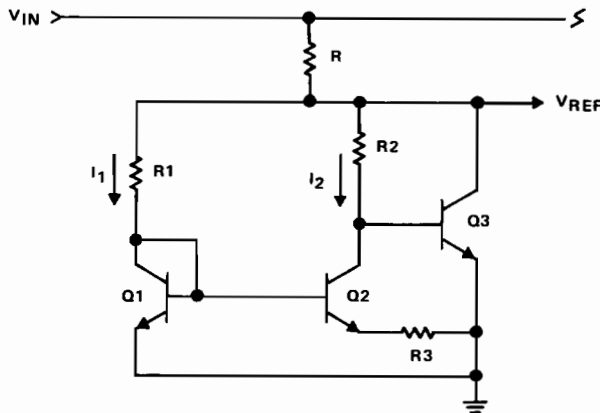

Figure 2.4. Band-Gap Reference

The resistor values of R1 and R2 are selected such that the current through transistors Q1 and Q2 are significantly different ($I_1 = 10 I_2$). The difference in current through transistors Q1 and Q2 results in a difference in their respective base-emitter voltages. This voltage differential ($V_{BE(Q1)} - V_{BE(Q2)}$) will appear across R3. With sufficiently high-gain transistors, the current I_2 passes through R3. I_2 is therefore equal to: $\frac{V_{BE(Q1)} - V_{BE(Q2)}}{R3}$

$$\therefore V_{REF} = V_{BE(Q3)} + (V_{BE(Q1)} - V_{BE(Q2)}) \frac{R2}{R3}$$

Analyzing the effect of temperature on V_{REF} : it can be shown that the difference in emitter-base voltage between two similar transistors operated at different currents is:

$$V_{BE(Q1)} - V_{BE(Q2)} = \frac{KT}{q} \ln \frac{I_1}{I_2}$$

where

K = Boltzmann's constant

T = absolute temperature

q = charge of an electron

I = current

The base-emitter voltage of Q3 can also be expressed as

$$V_{BE(Q3)} = V_{go} \left(1 - \frac{T}{T_0}\right) + V_{BEO} \left(\frac{T}{T_0}\right)$$

where

V_{go} = band-gap potential

V_{BEO} = emitter-base voltage at T_0

V_{REF} can then be expressed as:

$$V_{REF} = V_{go} \left(1 - \frac{T}{T_0}\right) + V_{BEO} \left(\frac{T}{T_0}\right) + \frac{R2}{R3} \frac{KT}{q} \ln \frac{I_1}{I_2}$$

Differentiating with respect to temperature yields

$$\frac{dV_{REF}}{dt} = -\frac{V_{go}}{T_0} + \frac{V_{BEO}}{T_0} + \frac{R2}{R3} \frac{K}{q} \ln \frac{I_1}{I_2}$$

If R_2 , R_3 , and I_1 are appropriately selected such that

$$\frac{R_2}{R_3} \ln \frac{I_1}{I_2} = \left(V_{go} - V_{BE0(Q3)} \right) C$$

where

$$C = \frac{q}{KT_0}$$

and

$$V_{go} = 1.22 \text{ V}$$

The resulting

$$\frac{dV_{REF}}{dt} = 0$$

The reference is temperature-compensated.

The band-gap voltage reference is particularly advantageous for low-voltage applications ($V_{REF} = 1.2 \text{ V}$) and yields a reference level that is stable with supply and temperature variations.

2.2 SAMPLING ELEMENT

The sampling element employed on most integrated circuit voltage regulators is an R_1/R_2 resistor divider network (Figure 2.5) determined by the output-voltage to reference-voltage ratio.

$$\frac{V_{OUT}}{V_{REF}} = 1 + \frac{R_1}{R_2}$$

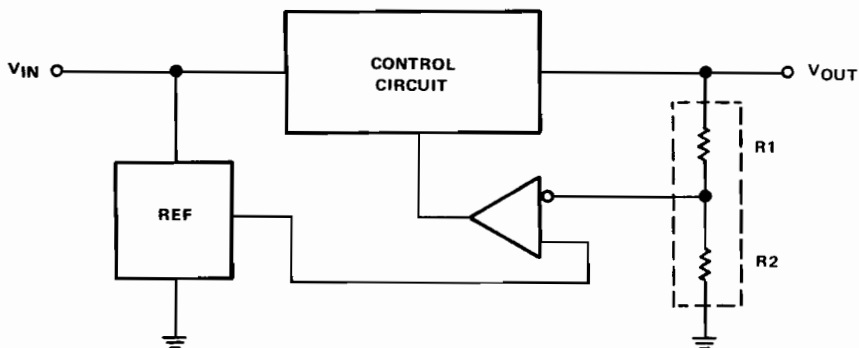

Figure 2.5. R_1/R_2 Ladder Network Sampling Element

Since the feedback voltage is determined by ratio and not absolute value, proportional variations in $R1$ and $R2$ have no effect on the accuracy of the integrated circuit voltage regulator. With proper attention given to the layout of these resistors in an integrated circuit, their contribution to the error of the voltage regulator will be minimal. The initial accuracy is the only parameter affected.

2.3 COMPARATOR

Provided a stable reference and an accurate output sampling element exist, the comparator then becomes the primary factor determining the voltage regulator's performance. Typical amplifier performance parameters such as offset, common-mode and supply rejection ratios, output impedance, and the temperature coefficient affect the accuracy and regulation of the voltage regulator over variations in supply, load, and ambient temperature conditions.

2.3.1 Offset

Offset voltage is viewed by the comparator as an error signal, as illustrated in Figure 2.6, and will cause the output to respond accordingly.

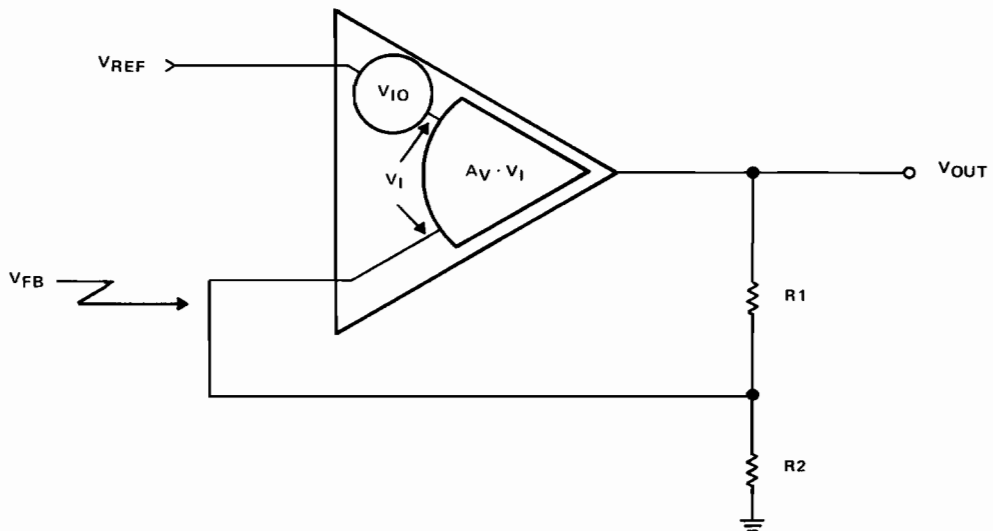

Figure 2.6. Comparator Model Showing Input Offset Voltage Effect

$$V_{OUT} = A_V V_I$$

$$V_I = V_{REF} - V_{IO} - V_{FB}$$

$$V_{FB} = V_{OUT} \left[\frac{R_2}{R_1 + R_2} \right]$$

$$V_{OUT} = \frac{V_{REF} - V_{IO}}{\frac{1}{A_V} + \left[\frac{R_2}{R_1 + R_2} \right]}$$

If A_V is sufficiently large

$$V_{OUT} = (V_{REF} - V_{IO}) \left(1 + \frac{R_1}{R_2} \right)$$

V_{IO} represents an initial error in the output of the integrated circuit voltage regulator. The simplest method of compensating for this error is to adjust the output voltage sampling element R_1/R_2 .

Offset Change with Temperature – The technique discussed above compensates for the comparator's offset voltage and yields an accurate regulator, but only at a specific temperature. As experienced in most amplifiers, the offset voltage varies with temperature proportional to the initial offset level. Trimming the feedback circuit as outlined for the externally adjustable regulator does not reduce the actual offset but merely counteracts it. When subjected to a different ambient temperature, the offset voltage changes and thus error is again introduced in the voltage regulator. Nulling the comparator for input offset improves on this problem as the offset voltage is corrected instead of compensated for. Monolithic integrated circuit regulators employ state-of-the-art technology to trim the integrated circuit amplifiers during the manufacturing process to all but eliminate offset. With minimal offset voltage, minimum drift will be experienced with temperature variations.

2.3.2 Supply Voltage Variations

The comparator's power supply and common-mode rejection ratios are the primary contributors to regulator error introduced by an unregulated input voltage. In an ideal amplifier, the output voltage is a function of the differential input voltage only. Realistically, the common-mode voltage of the input influences the output voltage also. The common-mode voltage is the average input voltage, referenced from the amplifier's virtual ground, as shown in Figure 2.7.

$$\text{Virtual Ground} = \frac{V_{CC+} + V_{CC-}}{2}$$

$$V_{IN(AV)} = \frac{V_S + V_{OUT} \left[\frac{R_2}{R_1 + R_2} \right]}{2}$$

$$V_{CM} = \frac{1}{2} \left[V_S + V_{OUT} \left(\frac{R_2}{R_1 + R_2} \right) - (V_{CC+} + V_{CC-}) \right]$$

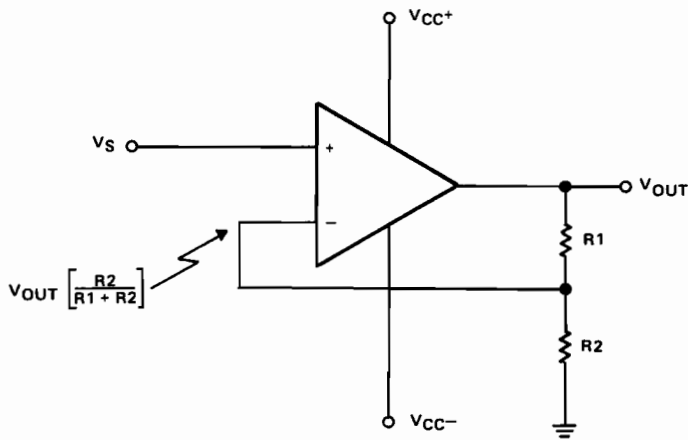

Figure 2.7. Comparator Model Showing Common-Mode Voltage

From this relation it can be seen that unequal variations in either supply rail will result in a change in the common-mode voltage.

The common-mode voltage rejection ratio (CMRR) is the ratio of the amplifier's differential voltage amplification to the common-mode voltage amplification.

$$CMRR = \frac{A_V}{A_{VCM}}$$

$$A_{VCM} = \frac{A_V}{CMRR}$$

That portion of output voltage contributed by the equivalent common-mode input voltage is:

$$V_{OUT} = V_{CM} A_{VCM} = \frac{A_V V_{CM}}{CMRR}$$

The equivalent error introduced then is:

$$\text{COMMON-MODE ERROR} = \frac{V_{CM}}{CMRR}$$

The common-mode error represents an offset voltage to the amplifier. Neglecting the actual offset voltage, the output voltage then becomes:

$$V_{OUT} = \left(V_{REF} + \frac{V_{CM}}{CMRR} \right) \left(1 + \frac{R1}{R2} \right)$$

The utilization of constant-current sources in most modern integrated circuits, however, yields a high power-supply rejection ratio, of such magnitude that the common-mode voltage effect on V_{OUT} can usually be neglected. Preregulation of the input voltage is another popular technique employed to minimize supply voltage variation effects. In addition to improving the effects of common-mode voltage, preregulation contributes to overall regulator performance.

3

Regulator Design Considerations

Various types of integrated circuit voltage regulators are available, each having its own particular characteristics and advantages in various applications. Which type used depends primarily on the designer's needs and trade-offs in performance and cost.

3.1 POSITIVE VERSUS NEGATIVE REGULATORS

As a rule, this division in voltage regulators is self-explanatory; a positive regulator is used to regulate a positive voltage while a negative regulator is used to regulate a negative voltage. What is positive and what is negative may vary, depending on the ground reference.

Figure 3.1 shows the conventional positive and negative voltage regulator applications employing a continuous and common ground. For systems operating on a single supply, the positive and negative regulators may be interchanged by floating the ground reference to the load or input. This approach to design is recommended only where the ground isolation serves as an advantage to the overall systems performance.

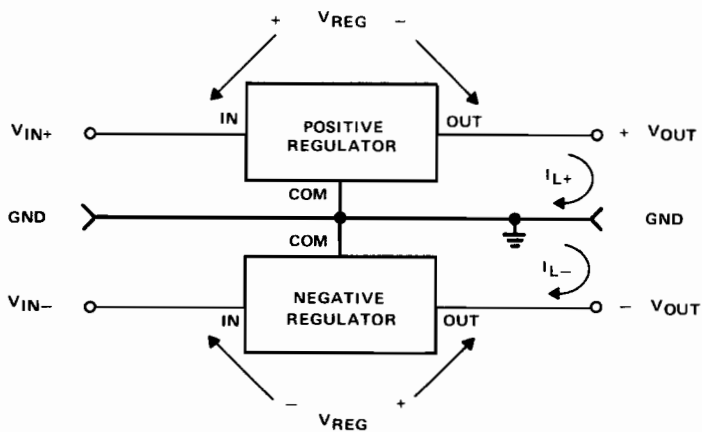

Figure 3.1. Conventional Positive/Negative Regulator

Figures 3.2 and 3.3 show a positive regulator in a negative configuration and a negative regulator in a positive configuration, respectively.

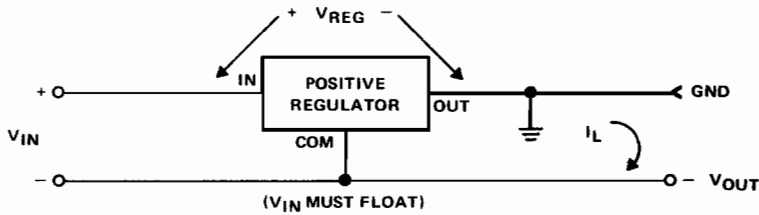

Figure 3.2. Positive Regulator in Negative Configuration (V_{IN} Must Float)

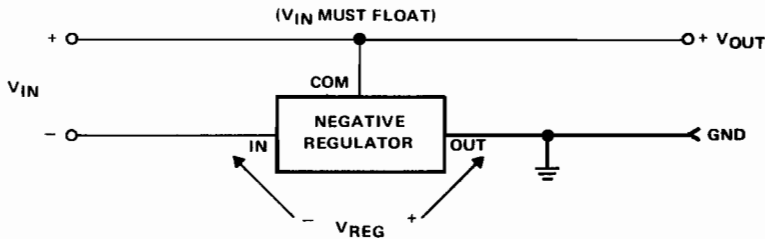

Figure 3.3. Negative Regulator in Positive Configuration (V_{IN} Must Float)

3.2 FIXED VERSUS ADJUSTABLE REGULATORS

A proliferation of fixed three-terminal voltage regulators offered in various current ranges are currently available from most major integrated circuit manufacturers. These regulators offer the designer a simple, inexpensive method to establish a regulated voltage source. Their particular advantages are:

1. Ease of use
2. No external components required
3. Reliable performance
4. Internal thermal protection
5. Short-circuit protection

But life is not all roses. The fixed three-terminal voltage regulators cannot be precisely adjusted since their output voltage sampling elements are internal. The initial accuracy of these devices may vary as much as $\pm 5\%$ from the nominal value and the output voltages available are limited. Current limits are based on the voltage regulator's applicable current range and are not adjustable. (See selection charts for available voltages and currents.) Extended range operation (increasing I_{LOAD}) is cumbersome and requires complex external circuitry.

The adjustable regulator caters to these applications, depending on the complexity of the adjustable voltage regulator. All adjustable regulators require external feedback, which allows the designer a precise and infinite voltage selection.

In addition, the output sense may be referred to a remote point. This allows the designer not only to extend the range of the regulator with minimal external circuitry, but also to compensate for losses in a distributed load or external pass element components. Additional features found on many adjustable voltage regulators are adjustable short-circuit current limiting, access to the voltage reference element, and shutdown circuitry.

3.3 DUAL-TRACKING REGULATORS

The tracking regulator (Figure 3.4) provides regulation for two rails, usually one positive and one negative. The dual-tracking feature assures a balanced supply system by monitoring both voltage rails. If either of the voltage rails droops or goes out of regulation, the tracking regulator will cause the associated voltage rail to vary proportionally. (A 10% sag in the positive rail will result in a 10% sag in the negative rail.) These regulators are, for the most part, restricted to those applications where balanced supplies offer a defined performance improvement such as in linear systems.

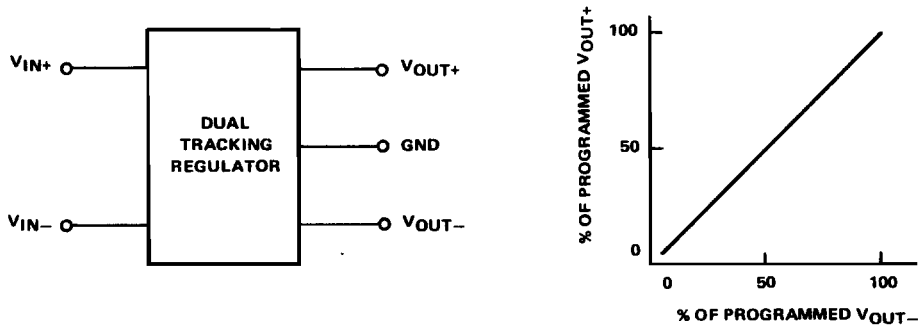

Figure 3.4. Dual Tracking Regulator

3.4 SERIES REGULATORS

The series regulator is well suited for medium current applications with nominal voltage differential requirements. Modulation of a series pass control element to maintain a well regulated prescribed output voltage is a straightforward design technique. Safe-operating-area protection circuits such as overvoltage, fold-back current limiting, and short-circuit protection are easily adapted. The primary drawback of the series regulator is its consumption of power. The series regulator (Figure 3.5) will consume power according to the load, proportional to the differential-voltage to output-voltage ratio. This becomes considerable with increasing load or differential voltage requirements. This power represents a loss to the system, and limits the amount of power deliverable to the load since the power dissipation of the series regulator is limited.

$$P_{REG} = V_{IN} I_{IN} - V_{OUT} I_{LOAD}$$

$$I_{IN} = I_{REG} + I_{LOAD}$$

Since $I_{LOAD} \gg I_{REG}$

$$I_{IN} \approx I_{LOAD}$$

$$\therefore P_{REG} \approx I_{LOAD} (V_{IN} - V_{OUT})$$

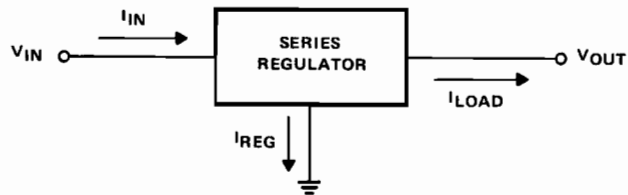

Figure 3.5. Series Regulator

3.5 FLOATING REGULATOR

The floating regulator (Figure 3.6) is a variation of the series regulator. The output voltage is maintained constant by varying the input-to-output voltage differential for a varying input voltage. The floating regulator's differential voltage is modulated such that its output voltage, referred to its common terminal $[V_{OUT(reg)}]$, is equal to its internal reference (V_{REF}). The voltage developed across the output to common terminal is equal to the voltage developed across $R1$ (V_{R1}).

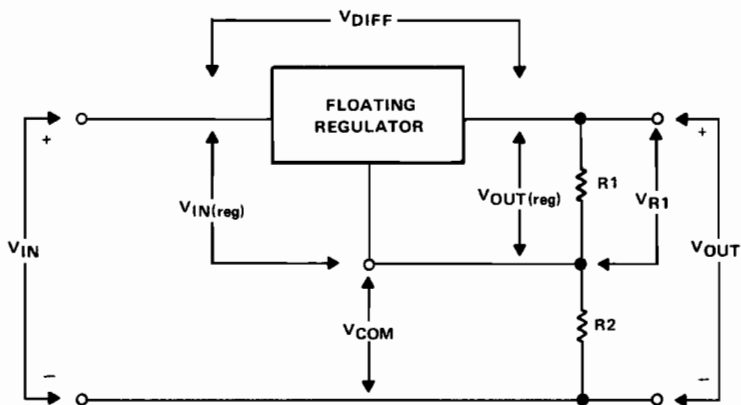

Figure 3.6. Floating Regulator

$$V_{OUT(reg)} = V_{REF} = V_{R1}$$

$$V_{R1} = V_{OUT} \left(\frac{R1}{R1 + R2} \right)$$

$$V_{OUT} = V_{REF} \left(1 + \frac{R2}{R1} \right)$$

The common-terminal voltage is:

$$V_{COM} = V_{OUT} - V_{R1} = V_{OUT} - V_{REF}$$

The input voltage seen by the floating regulator is:

$$V_{IN(reg)} = V_{IN} - V_{COM}$$

$$V_{IN(reg)} = V_{IN} - V_{OUT} + V_{REF}$$

$$V_{IN(reg)} = V_{DIFF} + V_{REF}$$

Since V_{REF} is fixed, the only limitation on the input voltage is the allowable differential voltage. This makes the floating regulator especially suited for high-voltage applications ($V_{IN} > 40\text{ V}$).

Practical values of output voltage are limited to practical ratios of output-to-reference voltages.

$$\frac{R_2}{R_1} = \frac{V_{OUT}}{V_{REF}} - 1$$

The floating regulator exhibits power consumption characteristics similar to that of the series regulator from which it is derived, but unlike the series regulator, it can also serve as a current regulator as shown in Figure 3.7.

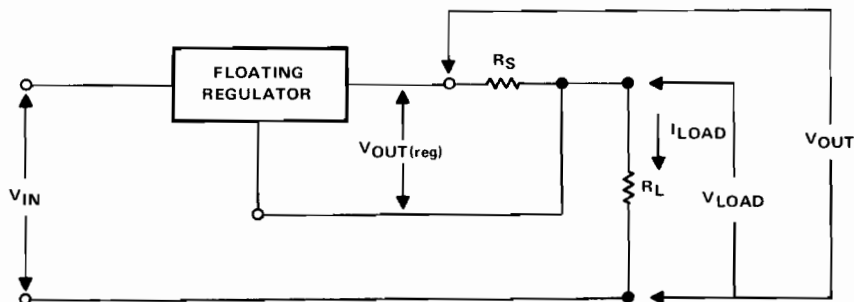

Figure 3.7. Floating Regulator as a Constant-Current Regulator

$$V_{OUT} = V_{REF} \left(1 + \frac{R_L}{R_S} \right)$$

$$V_{OUT} = V_{LOAD} + V_{OUT(reg)}$$

$$V_{\text{OUT(reg)}} = V_{\text{REF}}$$

$$\therefore V_{\text{LOAD}} = V_{\text{REF}} \left(1 + \frac{R_L}{R_S} \right) - V_{\text{REF}}$$

$$V_{\text{LOAD}} = V_{\text{REF}} \left(\frac{R_L}{R_S} \right)$$

$$I_{\text{LOAD}} = \frac{V_{\text{LOAD}}}{R_L}$$

$$I_{\text{LOAD}} = \frac{V_{\text{REF}}}{R_S}$$

The load current (I_{LOAD}) is independent of R_L .

3.6 SHUNT REGULATOR

The shunt regulator, shown in Figure 3.8, is the simplest of all regulators. It employs a fixed resistor as its series pass element. Changes in input voltage or load current requirements are compensated by modulating the current shunted to ground through the regulator.

For changes in V_{IN} : $\Delta I_Z = \frac{\Delta V_{\text{IN}}}{R_S}$

For changes in I_{LOAD} : $\Delta I_Z = -\Delta I_{\text{LOAD}}$

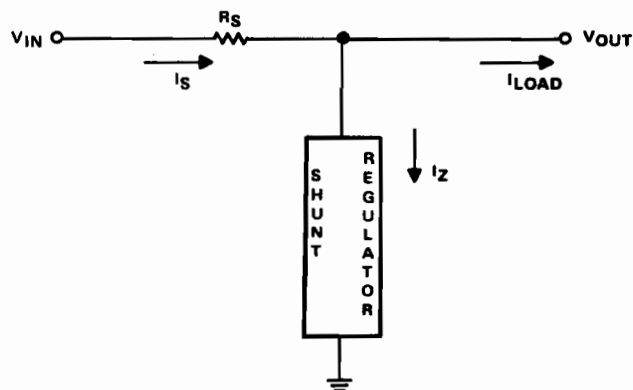

Figure 3.8. Shunt Regulator

The inherent short-circuit-proof feature of the shunt regulator makes it particularly attractive for some applications. The output voltage will be maintained until the load current required is equal to the current through the series element (see Figure 3.9).

$$I_{\text{LOAD}} = I_S \quad (I_Z = 0)$$

Since the shunt regulator cannot source current, additional current required by the load will result in a depreciation of the output voltage to zero.

$$V_{\text{OUT}} = V_{\text{IN}} - I_{\text{LOAD}} R_S$$

The short-circuit current of the shunt regulator then becomes:

$$V_{\text{OUT}} = 0 \text{ V}$$

$$I_{\text{SC}} = \frac{V_{\text{IN}}}{R_S}$$

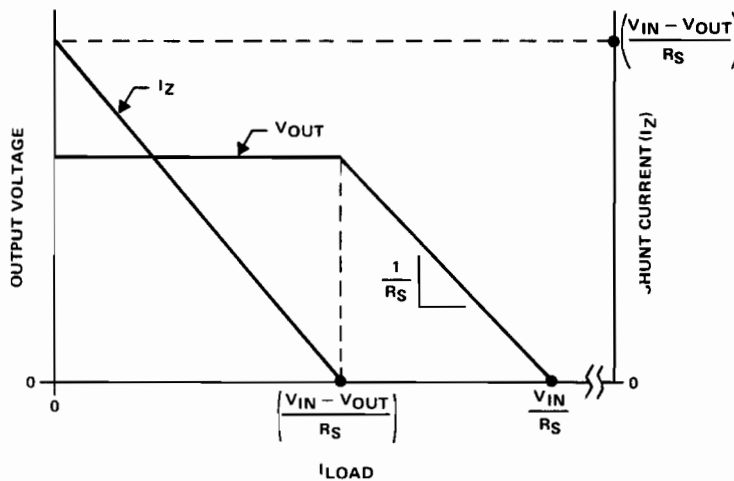

Figure 3.9. Output Voltage vs Load Current vs Shunt Current of a Shunt Regulator

3.7 SWITCHING REGULATOR

The switching regulator lends itself primarily to the higher power applications or those applications where power supply and system efficiency are of the utmost concern. Unlike the series regulator, the switching regulator operates its control element in an on or off mode. Switching regulator control element modes are shown in Figure 3.10. In this manner, the control element

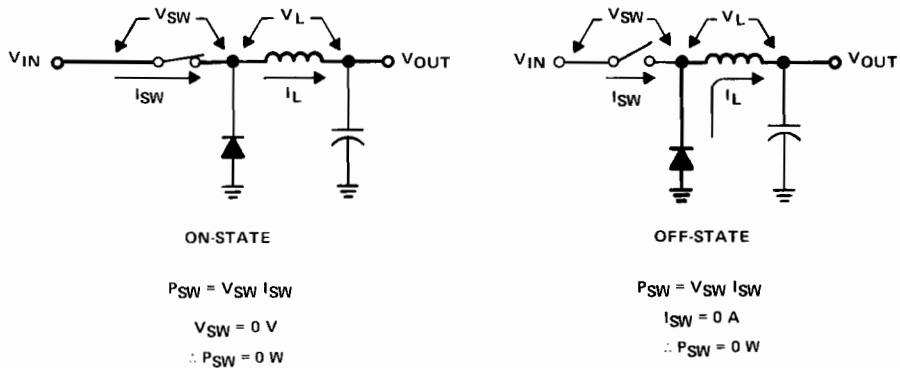

Figure 3.10. Switching Voltage Regulator Modes

is subjected to a high current at a very low voltage or a high differential voltage at a very low current; in either case the power dissipation in the control element is minimal. Changes in the load or input voltage are compensated for by varying the on-off ratio (duty cycle) of the switch, without increasing the internal power dissipated in the switching regulator. Operation of the switching regulator is illustrated in Figure 3.11.

For the output voltage to remain constant, the net charge in the capacitor must remain constant. This means the charge delivered to the capacitor must be dissipated in the load.

$$I_C = I_L - I_{LOAD}$$

$$I_C = - I_{LOAD} \text{ for } I_L = 0$$

$$I_C = I_{L(pk)} - I_{LOAD} \text{ for } I_L = I_{L(pk)}$$

The capacitor current waveform then becomes that shown in Figure 3.11(b). The charge delivered to the capacitor and the charge dissipated by the load are equal to the areas under the capacitor current waveform.

$$\Delta Q_+ = \frac{1}{2} \frac{(I_{L(pk)} - I_{LOAD})^2}{I_{L(pk)}} t \left(\frac{V_{IN}}{V_C} \right)$$

$$\Delta Q_- = I_{LOAD} \left[T - \frac{1}{2} t \left(\frac{V_{IN}}{V_C} \right) - \frac{1}{2} t \left(\frac{I_{L(pk)} - I_{LOAD}}{I_{L(pk)}} \right) \left(\frac{V_{IN}}{V_C} \right) \right]$$

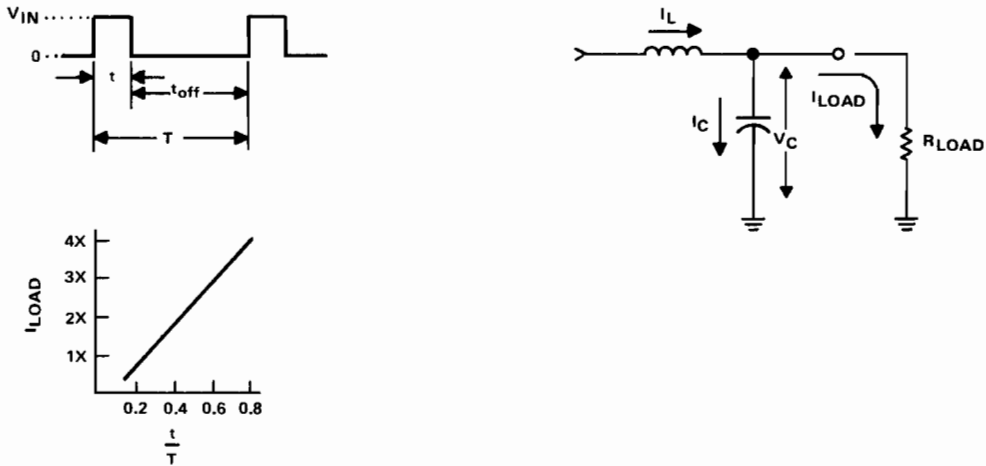

(a)

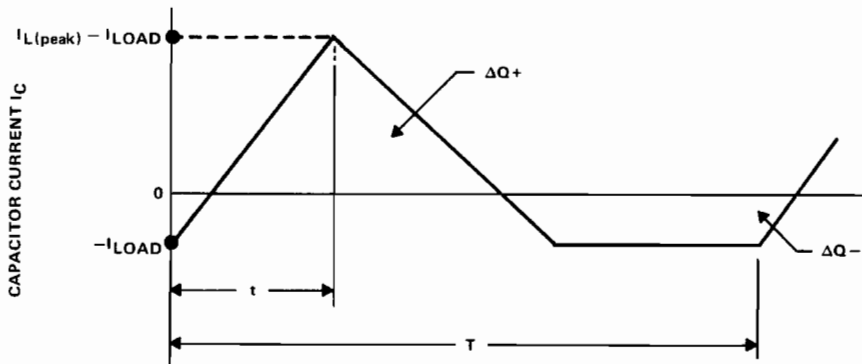

(b)

Figure 3.11. Variation of Pulse Width versus Load

By setting $\Delta Q+$ equal to $\Delta Q-$, the relation of I_{LOAD} and I_L for $\Delta Q = 0$ can be determined;

$$I_{LOAD} = \frac{1}{2} I_{L(pk)} \left(\frac{V_{IN}}{V_C} \right) \left(\frac{t}{T} \right)$$

As this demonstrates, the duty cycle $\frac{t}{T}$ can be altered to compensate for input-voltage changes or load variations.

The duty cycle $\frac{t}{T}$ can be altered a number of different ways.

3.7.1 Fixed On-Time, Variable Frequency

One technique is to constantly maintain a fixed or predetermined "on" time (t , the time the input voltage is being applied to the LC filter) and vary the duty cycle by varying the frequency ($\frac{1}{T}$). This method provides ease of design in voltage conversion applications (step-up, step-down, or invert) since the charge developed in the inductor of the LC filter during the on-time (which is fixed) determines the amount of power deliverable to the load. Thus calculation of the inductor is fairly straightforward.

$$L = \frac{V}{I} t$$

where:

L = value of inductance in microhenrys

V = differential voltage in volts

I = required inductor current defined by the load in amps

t = on-time in microseconds

The fixed-on-time approach is also advantageous from the standpoint that a consistent amount of charge is developed in the inductor during the fixed on-time. This eases the design of the inductor by defining the operating area to which the inductor is subjected.

The operating characteristic of a fixed-on-time switching voltage regulator is a varying frequency, which changes directly with changes in the load. This can be seen in Figure 3.12.

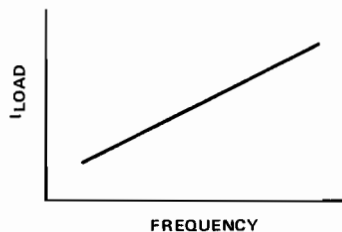

Figure 3.12. Frequency versus Load Current for Fixed On-Time SVR

3.7.2 Fixed Off-Time, Variable Frequency

In the fixed-off-time switching voltage regulator, the average dc voltage is varied by changing the on-time (t) of the switch while maintaining a fixed off-time (t_{off}). The fixed-off-time switching voltage regulator behaves opposite that of the fixed-on-time regulators in that as the load current increases, the on-time is made to increase, thus decreasing the operating frequency; this can be seen in Figure 3.13. This approach provides for the design of a switching voltage regulator that will

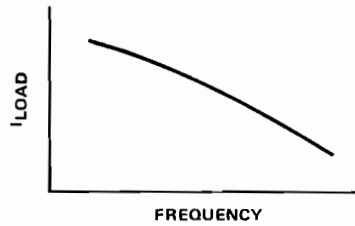
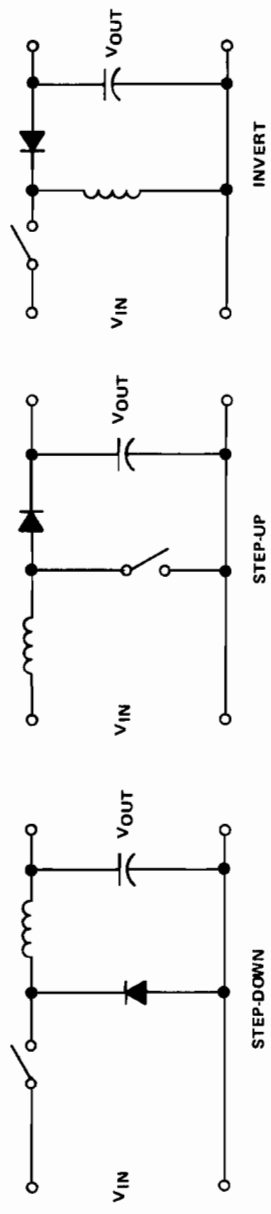

Figure 3.13. Frequency versus Load Current for Fixed Off-Time SVR

operate at a well-defined minimum frequency under full-load conditions. The fixed-off-time approach also allows a dc current to be established in the inductor under increased load conditions, thus reducing the ripple current while maintaining the same average current. The maximum current experienced in the inductor under transient load conditions is not as well defined as that above. Thus additional precaution should be taken to ensure the saturation characteristics of the inductor are not exceeded.

3.7.3 Fixed Frequency, Variable Duty Cycle

The fixed-frequency switching regulator varies the duty cycle of the pulse train to change the average power. The fixed-frequency concept is particularly advantageous for systems employing transformer-coupled output stages. The fixed-frequency aspect enables efficient design of the associated magnetics. Taking advantage of its compatibility in transformer-coupled circuits and the advantages of the transformer in single and multiple voltage-conversion applications, the fixed-frequency switching voltage regulator is used extensively in mainframe power supply control circuits. As with the fixed-off-time switching regulator, in single-ended applications the fixed-frequency regulator will establish a dc current through the inductor for increased load conditions to maintain the required current transferred with minimal ripple current. The single-ended and transformer-coupled circuit configurations are shown in Figure 3.14.



SINGLE-ENDED CONFIGURATIONS

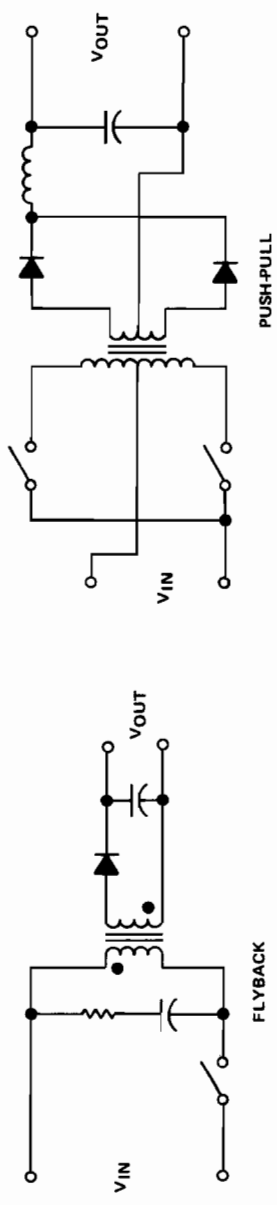

TRANSFORMER-COUPLED CIRCUITS

Figure 3.14. Switching Voltage Regulator Configurations

4

Regulator Safe Operating Area

Safe operating area is a term used to define the various supply voltage, input and output voltage, and load current ranges for which the device is designed to operate. Whether or not exceeding these limits will result in a catastrophic failure or merely render the device inoperative, depends on the device and its performance characteristics. Integrated circuit voltage regulators with internal current, thermal, and short-circuit protection circuits, for example, will merely shut down. External components, such as external pass transistors, may respond catastrophically.

4.1 REGULATOR SAFE OPERATING AREA

Although particular design equations depend on the type of integrated circuit voltage regulator and its application, there are several boundaries that apply to all regulator circuits for safe, reliable performance. A typical regulator specification is shown in Figure 4.1.

4.1.1 Input Voltage

The limits on the input voltage are derived from three considerations:

- | | |
|------------------------|---|
| $V_I \text{ max}$ | The absolute maximum rated input voltage as referenced to the regulator's ground. This is a safe operating area (SOA) destruct limit. |
| $V_{DIFF} \text{ min}$ | The minimum differential voltage input-to-output, below which the regulator ceases to function properly. This is a functional limit. |
| $V_{DIFF} \text{ max}$ | The maximum differential input voltage input-to-output. Usually, the regulator's power dissipation is exceeded prior to the $V_{DIFF} \text{ max}$ limit. This is an SOA limit that can be limited by $P_D \text{ max}$. |

4.1.2 Load Current

- | | |
|------------------------|---|
| $I_{LOAD} \text{ max}$ | The maximum load current deliverable from the integrated circuit regulator. If internal current limiting is not provided, external protection should be provided. This is a functional limit that may be further limited by $P_D \text{ max}$. |
|------------------------|---|

absolute maximum ratings over operating free-air temperature range (unless otherwise noted)

	LM105		LM205		LM305A		LM305 LM376		UNIT
	MIN	MAX	MIN	MAX	MIN	MAX	MIN	MAX	
Input voltage (see Note 1)	50		50		50		40		V
Input-to-output voltage differential	40		40		40		40		V
Continuous total dissipation at (or below) 25°C free-air temperature (see Note 2)	800		800		800		800		mW
Operating free-air temperature range	-55 to 125		-25 to 85		0 to 70		0 to 70		°C
Storage temperature range	-65 to 150		-65 to 150		-65 to 150		-65 to 150		°C
Lead temperature 1/16 inch from case for 60 seconds: JG or L package	300		300		300		300		°C
Lead temperature 1/16 inch from case for 10 seconds: P package			260		260		260		°C

NOTES: 1. Voltage values, except input to output voltage differential, are with respect to network ground terminal.
2. For operation above 25°C free-air temperature, refer to Dissipation Derating Curves, Figures I, II, and IV, page 90. This rating for the L package requires a heat sink that provides a thermal resistance from case to free-air, $R_{\theta CA}$, of not more than 105°C/W.

recommended operating conditions

	LM105		LM205		LM305A		LM305		LM376		UNIT
	MIN	MAX	MIN	MAX	MIN	MAX	MIN	MAX	MIN	MAX	
Input voltage, V_I	8.5	50	8.5	50	8.5	50	8.5	40	9	40	V
Output voltage, V_O	4.5	40	4.5	40	4.5	40	4.5	30	5	37	V
Input-to-output voltage differential, $V_I - V_O$	3	30	3	30	3	30	3	30	3	30	V
Output current, I_O	0	12	0	12	0	45	0	12	0	25	mA
Operating free-air temperature, T_A	-55	125	-25	85	0	70	0	70	0	70	°C

Figure 4.1. Typical Regulator Specification

4.1.3 Power Dissipation

$P_D \text{ max}$ The maximum power that can be dissipated within the regulator. Power dissipation is the product of the input-to-output differential voltage and the load current, and is normally specified at or below a given case temperature. This rating is usually based on a 150°C junction temperature limit. The power rating is an SOA limit unless the integrated circuit regulator provides an internal thermal protection.

4.1.4 Output Voltage of an Adjustable-Voltage Regulator

$V_O \text{ min}$ The minimum output voltage a regulator is capable of regulating. This is usually a factor of the regulator's internal reference and is a functional limit.

$V_O \text{ max}$ The maximum output voltage a regulator is capable of regulating. This is largely dependent on the input voltage ($V_O \text{ max} \leq V_I - V_{DIFF \text{ min}}$). As with the minimum differential voltage limit, the maximum output voltage is a functional limit.

4.2 EXTERNAL PASS TRANSISTOR

For applications requiring additional load current, integrated circuit voltage regulators may be boosted with the addition of an external pass transistor. When employed, the external pass transistor, in addition to the voltage regulator, must be protected against operation beyond its safe operating area. Operation outside the safe operating area is catastrophic to most discrete transistors.

$I_C \text{ max}$ The maximum current the transistor is capable of sustaining. $I_C \text{ max}$ now becomes the max load current the regulator circuit is capable of delivering to the load. Associated with $I_C \text{ max}$ is a collector-emitter voltage, V_{CE} . If this voltage is greater than the input-to-output differential voltage of the regulator application, the $I_C \text{ max}$ will have to be derated. This will then become a functional limit instead of a catastrophic limit. $I_C \text{ max}$ is related to power dissipation and junction or case temperature. $I_C \text{ max}$ must again be derated if the thermal or power ratings at which it is specified are exceeded. The resulting derated $I_C \text{ max}$ should continue to be considered as a catastrophic limit. Actual $I_C \text{ max}$ limits and derating information will appear on the individual transistor specification.

$V_{CE} \text{ max}$ The maximum collector-emitter voltage that can be applied to the transistor in the off-state. Exceeding this limit will result in breaking down the collector-emitter junction of the pass transistor. This is not catastrophic if current limiting is provided. If current limiting is not provided, it will destroy the transistor.

$P_D \text{ max}$ The maximum power that can be dissipated in the device. This is usually specified at a specific junction or case temperature. If the transistor is operated at higher temperatures, the maximum power must be derated in accordance with the operating rules specified in the transistor's applicable specification. Prolonged operation above the transistor's maximum power rating will result in degradation or destruction of the transistor.

4.3 SAFE OPERATING PROTECTION CIRCUITS

Proper selection of the integrated circuit voltage regulators and external components will allow a reliable design wherein all devices operate well within their respective safe operating areas. If the system design is such that under normal conditions the devices operate to within 80% of their capabilities, fault conditions, such as a short-circuit or excessive load, may cause some components in the regulator circuit to exceed their safe operating area operation. For this purpose as well as protection for the load, certain protection circuits should be considered.

4.3.1 Reverse Bias Protection

This condition may occur when a voltage regulator becomes reverse biased, for example, if the input supply was "crowbarred" to protect either the supply itself or additional circuitry. The filter capacitor at the output of the regulator circuit will maintain the regulator's output voltage and the regulator circuit will be reverse biased. If the regulated voltage is large enough ($> 7 \text{ V}$), the regulator circuit may be damaged. To protect against this, a simple diode can be employed as shown in Figure 4.2.

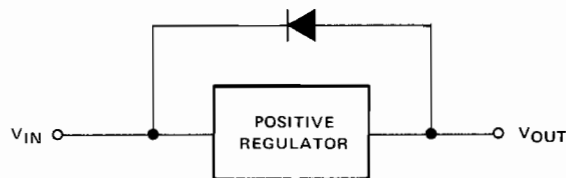

Figure 4.2. Reverse Bias Protection

4.3.2 Current Limiting Techniques

The type of current limiting scheme employed depends primarily on the safe operating area of the applicable pass element. The three basic techniques are series resistor, constant current, and fold-back current limiting.

Series Resistor – This is the simplest method for short-circuit protection. The short-circuit current is determined by the current-limiting resistor R_{CL} , as shown in Figure 4.3.

$$V_{OUT} = V_{OUT(reg)} - I_{LOAD} R_{CL}$$

A short-circuit condition occurs when $V_{OUT} = 0$, thus:

$$I_{SC} = I_{LOAD} @ (V_{OUT} = 0) = \frac{V_{OUT(reg)}}{R_{CL}}$$

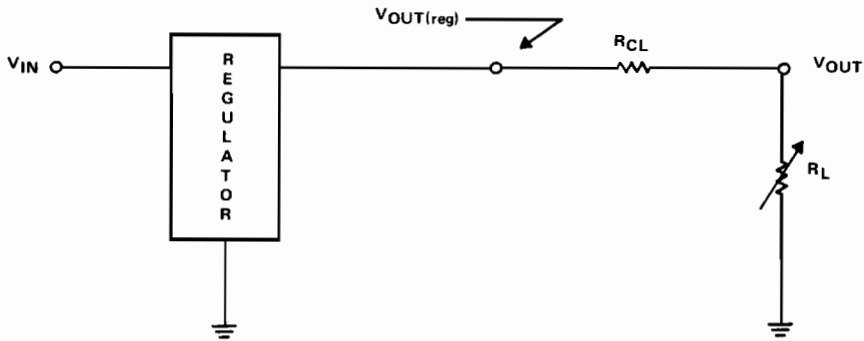

Figure 4.3. Series Resistance Current Limiter

The primary drawback of this technique is error introduced by the voltage dropped across R_{CL} under varying load conditions.

$$I_{LOAD} = \frac{V_{OUT}}{R_L}$$

$$V_{OUT} = \frac{V_{OUT(reg)}}{1 + \frac{R_{CL}}{R_L}}$$

$$\% \text{ ERROR} = \frac{V_{OUT(reg)} - V_{OUT}}{V_{OUT(reg)}}$$

$$\% \text{ ERROR} = \frac{R_{CL}}{R_L + R_{CL}}$$

Maintaining R_{CL} at a level of an order of magnitude less than the nominal load impedance minimizes this effect.

$$R_{CL} = \frac{1}{10} R_L \quad \% \text{ ERROR} = 9.1\%$$

This also yields a short-circuit current an order of magnitude greater than the normal operating load current.

$$I_{LOAD(nom)} = \frac{V_{OUT(reg)}}{R_{CL} + R_{L(nom)}}$$

$$I_{SC} = \frac{V_{OUT(reg)}}{R_{CL}}$$

$$I_{SC} = 11 \cdot I_{LOAD(nom)}$$

This is inefficient since it requires a regulator or pass element with capabilities in excess (11X) of its normal operation.

These performance characteristics of a series resistance current limited regulator are shown in Figure 4.4.

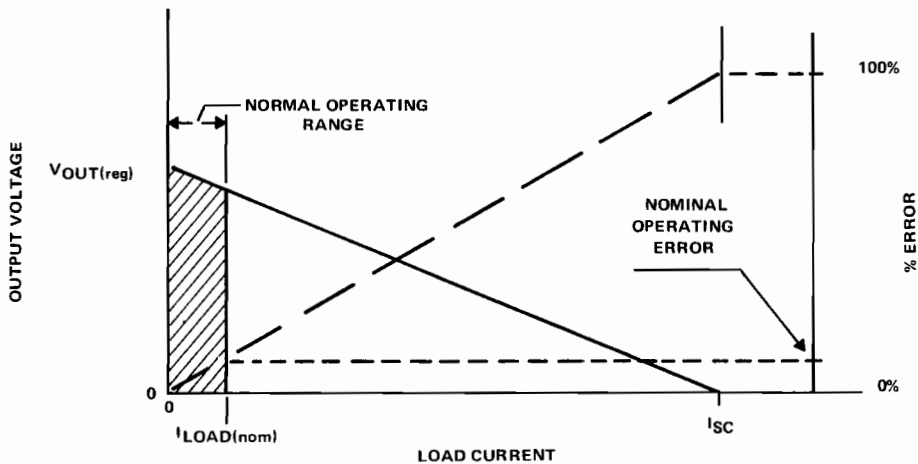

Figure 4.4. Performance Characteristics of a Series Resistance Current-Limited Regulator

Constant-Current Limiting – Constant-current limiting is the most popular current-limiting technique in low-power, low-current regulator circuits. The basic configuration is shown in Figure 4.5. Implementation of this method requires access to the control element and remote voltage sense capabilities. Sensing the output voltage beyond the current limit, the circuit allows the regulator to compensate for voltage changes across R_{CL} for varying load conditions.

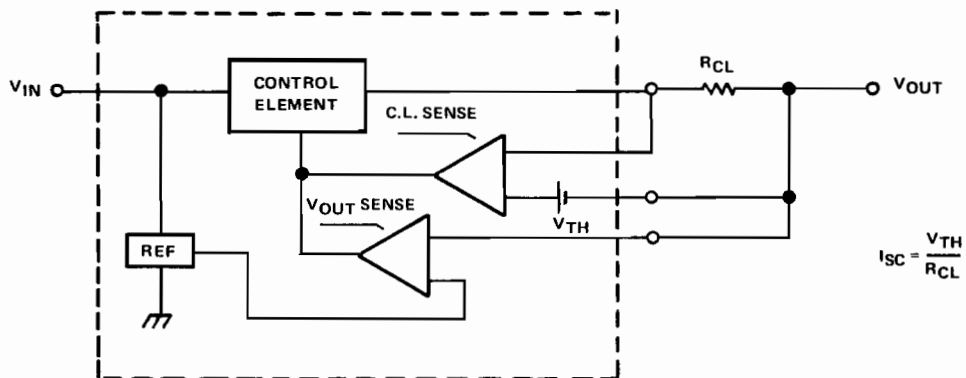

Figure 4.5. Constant Current Limit Configuration

If an external pass transistor is used, its base current may be starved to accomplish constant-current limiting, as shown in Figure 4.6. Current limiting takes effect as the voltage drop across R_{CL} approaches the potential required to turn "on" the transistor Q1. As Q1 is biased on, the current supplying the base of Q2 is diverted, turning "off" Q2, thus decreasing the drive current to Q3, the regulator's pass transistor. If access to the internal control element is available, it should be used. This provides for the reduction of the current through the regulator's control element (Q2) as well as the pass element (Q3). The performance characteristics of a constant-current-limited regulator are as shown in Figure 4.7.

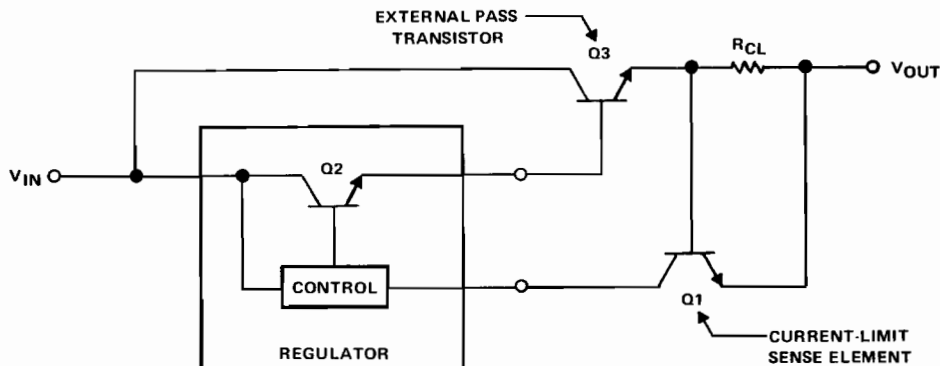

Figure 4.6. Constant-Current Limiting for External Pass Transistor Applications

It should be noted that short-circuit conditions are the worst conditions imposed on the pass transistor since it has to survive not only the short-circuit current but it has to withstand the full input voltage across its collector-emitter junction simultaneously.

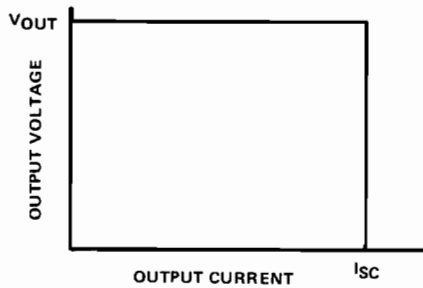

Figure 4.7. Constant-Current Limiting

This normally requires use of a pass transistor whose power handling capabilities are an order of magnitude greater than required for normal operation, i.e.:

$$V_{IN} = 20 \text{ V} \quad V_{OUT} = 12 \text{ V} \quad I_{OUT} = 700 \text{ mA}$$

$$\text{NOMINAL } P_D = (20 \text{ V} - 12 \text{ V}) \cdot 0.7 \text{ A} = 5.6 \text{ W}$$

For $I_{SC} = 1 \text{ A}$ (150% I_{OUT}):

$$\text{SHORT-CIRCUIT } P_D = 20 \text{ V} \cdot 1 \text{ A} = 20 \text{ W}$$

Fold-Back Current Limiting – Fold-back current limiting is used primarily for high-current applications where the normal operation requirements of the regulator dictate the use of an external power transistor. The principle of fold-back current limiting provides limiting at a predetermined current I_K at which feedback reduces the available load current as the load continues to increase (R_L decreasing) or the output voltage decays. The voltage-current relation is illustrated in Figure 4.8.

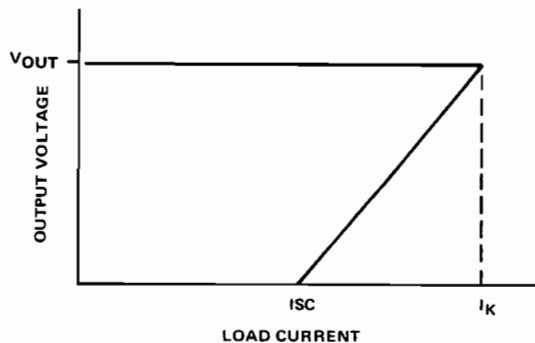

Figure 4.8. Fold-Back Current Limiting

The fold-back current-limiting circuit of Figure 4.9 behaves similarly to the constant-current limit circuit shown in Figure 4.6. In the configuration shown in Figure 4.9, the potential developed across the current limit sense resistor R_{CL} must not only develop the base-emitter voltage required to turn on Q1, but it must develop sufficient potential to overcome the voltage across resistor R1.

$$V_{BE(Q1)} = R_{CL} I_{LOAD} - \frac{V_{OUT} + R_{CL} I_{LOAD}}{R1 + R2} R1$$

$$\therefore I_K = \frac{V_{BE(Q1)} (R1 + R2) + V_{OUT} R1}{R_{CL} R2}$$

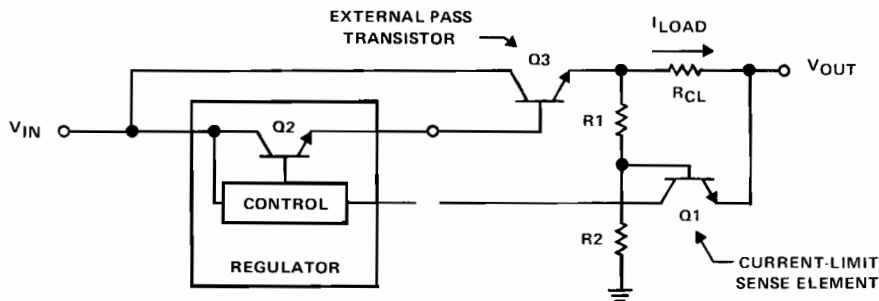

Figure 4.9. Fold-Back Current Limit Configuration

As the load current requirement increases, the output voltage (V_{OUT}) decays. The decreasing output voltage results in a proportional decrease in voltage across R1. Thus, less current through R_{CL} is required to develop sufficient potential to maintain the forward-biased condition of Q1. This can be seen in the above expression for I_K . As V_{OUT} decreases, I_K decreases. Under short-circuit conditions ($V_{OUT} = 0$ V) I_K becomes

$$I_{SC} = I_K @ (V_{OUT} = 0 \text{ V}) = \frac{V_{BE(Q1)}}{R_{CL}} \left[1 + \frac{R1}{R2} \right]$$

The approach shown in Figure 4.10 allows a more efficient design because the collector current of the pass transistor is less during short-circuit condition than it is during normal operation. This means that during short-circuit conditions when the voltage across the collector-emitter junction of the pass transistor is maximum, the collector current is reduced. This more closely fits the typical performance characteristics of the transistor and allows more efficient design matching of the characteristics for the pass transistor to that of the regulator.

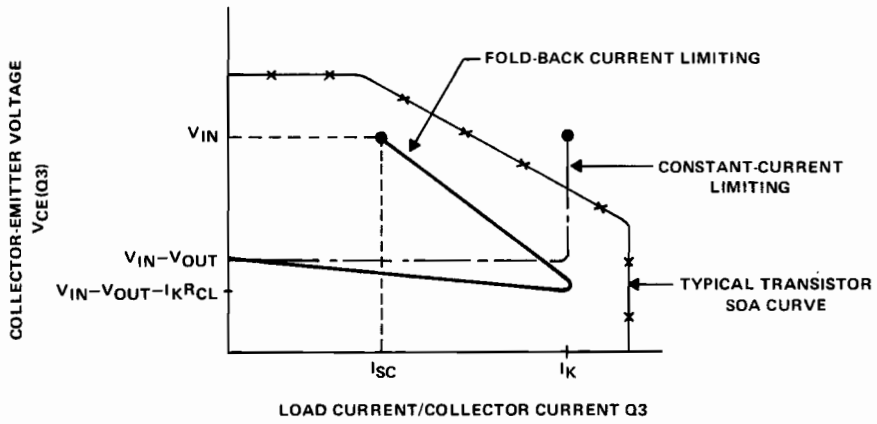

Figure 4.10. Fold-Back Current Limit Safe Operating Area

5

Thermal Considerations

5.1 THERMAL EQUATION

One of the primary limitations on the performance of any regulator is its rated power dissipation. The maximum power dissipation of a semiconductor is determined by the maximum junction temperature at which the device will operate and the device's ability to dissipate heat generated internally. A device's capability to expel the heat generated internally is defined by its thermal resistance; that is, its temperature rise per unit of heat transfer or power dissipated, expressed in units of Celsius degrees per watt. Knowing the rating of a particular device (allowable junction temperature) and the device's thermal resistance, the maximum power of that device may be calculated for a particular application or the required heat-sink thermal resistance can be determined for a desired power dissipation.

The basic relation for heat transfer or power dissipation may be expressed as:

$$P_D = \frac{\Delta T}{\Sigma R_{\theta}}$$

where:

P_D = power dissipated in the semiconductor devices in watts

ΔT = temperature difference created

ΣR_{θ} = sum of the thermal resistances of the media across which ΔT exists

For various semiconductor applications, the above expression may be written as follows:

$$P_D = \frac{T_J - T_A}{R_{\theta JC} + R_{\theta CS} + R_{\theta SA}}$$

$$P_D = \frac{T_J - T_A}{R_{\theta JA}}$$

where:

T_J = junction temperature of the semiconductor device in degrees Celsius

T_A = ambient temperature in degrees Celsius

$R_{\theta JC}$ = junction-to-case thermal resistance of the device ($^{\circ}\text{C}/\text{W}$)

$R_{\theta CS}$ = case-to-surface thermal resistance of the mounting technique ($^{\circ}\text{C}/\text{W}$)

$R_{\theta SA}$ = surface-to-ambient thermal resistance of the heat sink or media to which the semiconductor is mounted ($^{\circ}\text{C}/\text{W}$)

$R_{\theta JA}$ = junction-to-ambient thermal resistance of the device ($^{\circ}\text{C}/\text{W}$)

Figure 5.1 illustrates the various paths of heat flow, temperatures, and thermal resistances.

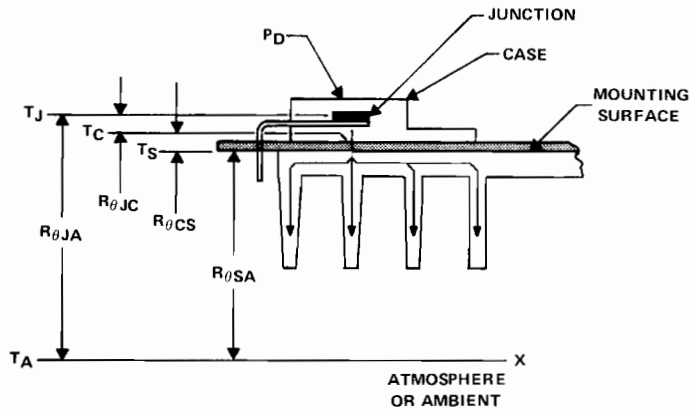

Figure 5.1. Semiconductor Thermal Model

The common practice is to represent the system with a network of series resistances as shown in Figure 5.2.

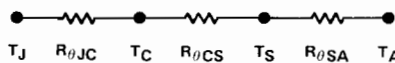

Figure 5.2. Resistor Network Representation of Figure 5.1

In short, the temperature at any point can be determined knowing the temperature at a given point, the power being dissipated, and the thermal resistance of the path of heat flow from the known location to the point of interest. If the path of heat flow travels through several media, the net thermal resistance is the sum of their thermal resistances.

From Figure 5.2, thermal resistance from junction-to-ambient is:

$$R_{\theta JA} = R_{\theta JC} + R_{\theta CS} + R_{\theta SA}$$

The use of the thermal equation is best illustrated through the use of examples.

5.1.1 Example 1: (P_D max)

Determine the maximum allowable power dissipation of a semiconductor device:

Given: $T_J \text{ max} = 150^\circ\text{C}$ (typical limit)
 $T_A = 70^\circ\text{C}$
 $R_{\theta JA} = 62.5^\circ\text{C/W}$ (TO-220AB package)

Calculating P_D max:

$$P_D = \frac{T_J - T_A}{R_{\theta JA}}$$
$$P_D = \frac{150^\circ\text{C} - 70^\circ\text{C}}{62.5^\circ\text{C/W}}$$
$$P_D \leq 1.28 \text{ watts}$$

5.1.2 Example 2: (T_A max)

Determine the maximum allowable ambient temperature of a device:

Given: P_D (device) = 750 mW
 $T_J \text{ max} = 150^\circ\text{C}$
 $R_{\theta JA} = 79^\circ\text{C/W}$ (TO-202AB package)

Calculating T_A max:

$$P_D = \frac{T_J - T_A}{R_{\theta JA}}$$
$$T_A = T_J - R_{\theta JA} P_D$$
$$T_A = 150^\circ\text{C} - 79^\circ\text{C/W} \times 750 \times 10^{-3} \text{ W}$$
$$T_A \leq 90.75^\circ\text{C}$$

5.1.3 Example 3: ($R_{\theta JA}$ max)

Determine whether or not a heat sink is required.

Given: P_D (device) = 1.25 W
 T_J max = 150°C
 T_A = 65°C
 $R_{\theta JA}$ = 108°C/W (TO-116, N package)

Calculating $R_{\theta JA}$ max:

$$P_D = \frac{T_J - T_A}{R_{\theta JA}}$$
$$R_{\theta JA} \text{ max} = \frac{T_J - T_A}{P_D}$$
$$R_{\theta JA} \text{ max} = \frac{150^\circ\text{C} - 65^\circ\text{C}}{1.25 \text{ W}}$$
$$R_{\theta JA} \text{ max} = 68^\circ\text{C/W}$$
$$R_{\theta JA} \text{ (device)} = 108^\circ\text{C/W}$$

therefore a heat sink is required.

5.1.4 Example 4: ($R_{\theta CA}$ max of Required Heat Sink)

From Example 3, determine the thermal resistance of the required heat sink and mounting technique.

Given: $R_{\theta JC}$ (device) = 44°C/W (TO-116, N package)

Calculating $R_{\theta CA}$:

From Example 3, $R_{\theta JA}$ max = 68°C/W with heat sink:

$$R_{\theta JA} \text{ (system)} = R_{\theta JC} \text{ (device)} + R_{\theta CS} \text{ (mount)} + R_{\theta SA} \text{ (sink)}$$

$$R_{\theta CS} \text{ (mount)} + R_{\theta SA} \text{ (sink)} = R_{\theta CA} \text{ (mount and sink)}$$

$$R_{\theta CA} = R_{\theta JA} \text{ (system)} - R_{\theta JC} \text{ (device)}$$

$$R_{\theta CA} = 68^{\circ}\text{C/W} - 44^{\circ}\text{C/W}$$

$$R_{\theta CA} \text{ max} = 24^{\circ}\text{C/W}$$

The Thermalloy 6007 heat sink for dual-in-line packages exhibits an $R_{\theta CA}$ of 20°C/W .

Tables 5.1 through 5.7 list the thermal resistances of the popular semiconductor packages, their mounting techniques, and commercially available heat sinks. Sources for obtaining these techniques and heat sinks are listed below.

Sources:

Thermalloy, Incorporated
Dallas, Texas
(214)-238-6821

IERC
Burbank, California
(213)-849-2481

Staver
Bayshore, New York
(516)-666-8000

Wakefield Engineering Inc.
Wakefield, Massachusetts
(617)-245-5900

Table 5.1. $R_{\theta JA}$ and $R_{\theta JC}$ – Thermal Resistances of Mounting Packages

JEDEC No.	TO-220AB	TO-202AB	TO-39	TO-226AA	TO-116	TO-116			Unit
TI Designator	KC	KD	L	LP	J	N	JG	P	
$R_{\theta JA}$	62.5	79	210	160	122	108	151	125	$^{\circ}\text{C/W}$
$R_{\theta JC}$	4	10	15	35	60	44	58	45	$^{\circ}\text{C/W}$

Table 5.2. $R_{\theta CS}$ – Thermal Resistance of Mounting Techniques

Package	Bare	With Thermal Grease	With Anodized Washer 0.020" Thk	With Mica Film 0.003" Thk	Unit
TO-220AB (KC)	3	1	1.2	1.8	$^{\circ}\text{C/W}$

*Most other package heat sinks account for mounting technique.

Table 5.3. Available Heat Sinks For TO-3 Packages

$R_{\theta SA}$ Range °C/W	IERC	Staver	Thermalloy	Wakefield
<0.5			6560, 6590, 6660, 6690	
0.5 to 1.0			6159, 6423, 6441, 6443, 6450, 6470	
1.0 to 3.0	E2 1/2" Extrusion		6006, 6123, 6129, 6157, 6169, 6401, 6403, 6421, 6427, 6442, 6463, 6500	641
3.0 to 5.0	E1, E3 1/2" Extrusion HP1 Series HP3 Series	V3-5-2	6004, 6005, 6016, 6053, 6054, 6176, 6141	621, 623 600 Series
5.0 to 7.0	UP Series	V3-7-224 V3-3-2	6002, 6003, 6015, 6052 6060, 6061	690, 390, 680 Series
7.0 to 10	LA Series	V3-3, V1-3 V3-5, V1-5 V3-7-96	6001, 6013, 6014, 6051	672
10 to 13	UP3 Series		6103, 6104, 6105	380 Series

Table 5.4. Available Heat Sinks For TO-226 and TO-92 Packages

Thermalloy	$R_{\theta CA}$ °C/W	Staver	$R_{\theta CA}$ °C/W	IERC	$R_{\theta CA}$ °C/W
2220	75	F2-7	72	RU Single	150
2224	92	F1-70 F1-8	72 72	RU Double RUR Single RUR Double	180 130 160

Table 5.5. Available Heat Sinks For TO-39 Packages

$R_{\theta CA}$ °C/W	IERC	Staver	Thermalloy
10 to 20	LP Series		1101, 1103, 1130, 1131 1132, 1117, 1116, 1121
20 to 40		F5-5C F5-5B	2227, 1136, 2212-5, 2228 2215, 2262, 2263, 1134
40 to 60	TXBF2-032-036B Thermal Link Series	F5-5A F6-5L F5-5D	2205, 2207/PR11, 2209-4A 2210, 2225, 2230-5, 2211 2226, 2260, 1129,
> 60	TXBF-032-025B TXBC-032-025B	F1-5	1115, 2257

Table 5.6. Available Heat Sinks For TO-220 Packages

$R_{\theta SA}$ Range °C/W	IERC	Staver	Thermalloy
3.0 to 5.0	HP1, HP3 Series	V3-5-2 T-79	6072/6071
5.0 to 8.0	UP Series	V3-3-2 V3-7-224	6072
8.0 to 13	LA Series UP3 Series	V3-5 V3-7-96 V3-3 V4-3-192 V5-1	6034 6032 6030
13 to 20	LB Series PSD1 PB1 Series	V4-3-128	6065, 6070/6071, 6070, 6106, 6038* 3069*, 6025, 6107
20 to 30	PB2 Series PA1 PSB2 PA2	F8-3-220*	6073 6045*
> 30	PSC2-26* PA27CB/PVC-1B*		

* Denotes Clip Mounted Heat Sink. (Thermal Ratings for These Devices are $R_{\theta CA}$).

Table 5.7. Available Heat Sinks For TO-202 Packages

$R_{\theta SA}$ Range °C/W	IERC	Staver	Thermalloy
< 10	LA Series HP1, HP3 Series UP Series		6034
10 to 15	LB Series UP3 PSD1	V4-3-192	6063
15 to 20 20 to 30	PB1 Series PA1, PA2, PB2 Series	V4-3-128 V6-2 F8-3-202*	6046* 6047*
30 to 40	PSC2* PA17CB/PVC-1B*	F7-1* F7-2* F7-3*	

* Denotes Clip Mounted Heat Sink. (Thermal Ratings for These Sinks Are $R_{\theta CA}$)

5.2 HEAT-SINK DESIGN

A wide variety of heat sinks is available commercially offering thermal resistances as low as 1°C/W. For a particular application, the use of a custom heat sink may be preferable. Such factors as convenience, cost, size, or weight determine which approach to take.

In designing a custom heat sink, first consider the three modes of heat transfer: (1) conduction, (2) radiation, and (3) convection. Figure 5.3 describes pictorially the heat flow paths from the junction of a typical semiconductor.

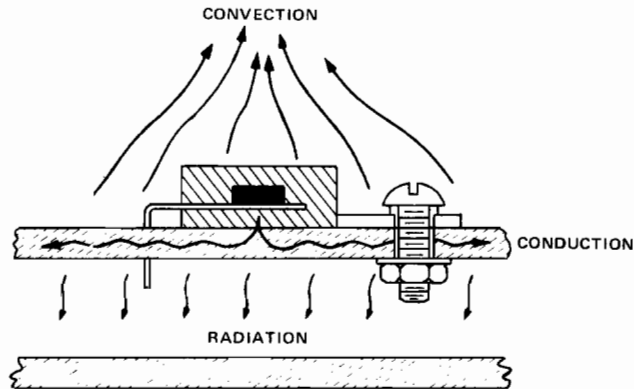

Figure 5.3. Heat Flow Paths of Semiconductor Cooling

5.2.1 Conduction

The basic law of heat conduction in the steady state is:

$$Q = \frac{KA \Delta T}{L}$$

where:

Q = rate of heat flow

K = thermal conductivity of the material

A = cross-sectional area

ΔT = temperature difference

L = length of the heat flow path

Where conduction is the only mode of heat transfer, the following rules should be observed:

1. Use materials that exhibit the highest thermal conductivity that is consistent with structural and economic requirements.
2. Utilize an optimum cross-sectional area.
3. Maintain T_2 (where $\Delta T = T_1 - T_2$) at as low a value as possible.
4. Keep the thermal path (L) as short as possible.

For quick solution of thermal conductivity problems, the nomograph in Figure 5.4 is a helpful aid.

Example – Using the example nomograph in Figure 5.4, solve $Q = \frac{KA \Delta T}{L}$ for ΔT .

$Q = 10 \text{ W}$
 $L = 0.25 \text{ in}$
 $K = 100 \text{ Btu/hr} \cdot \text{ft} \cdot ^\circ\text{F}$
 $A = 2 \text{ in}^2$
 $\Delta T = ?$

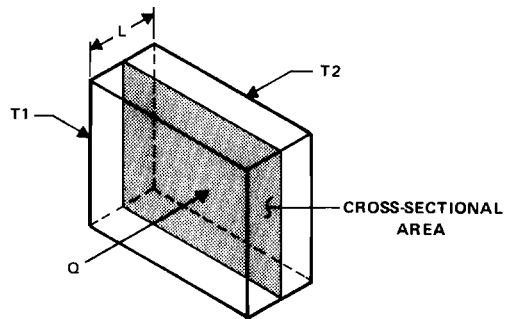

1. Plot the power in watts on the graduated scale Q (e.g., 10 W).
2. Plot the thickness of the heat sink on the L scale (e.g., 0.25 in).
3. Project a line between point 1 and point 2 to establish point 3 at the intersection of the projected line and reference line 1.
4. Plot the thermal conductivity on scale K (e.g., 100 Btu/hr · ft · °F).
5. Project a line between point 3 and point 4 to establish a point 5 at the intersection of the projected line and reference line 2.
6. Plot the cross-sectional area on the A scale (e.g., 2 in²).
7. Determine the thermal gradient (ΔT) by projecting a line from point 5 through point 6 and intersecting the ΔT scale. This intersection indicates the ΔT of the system.

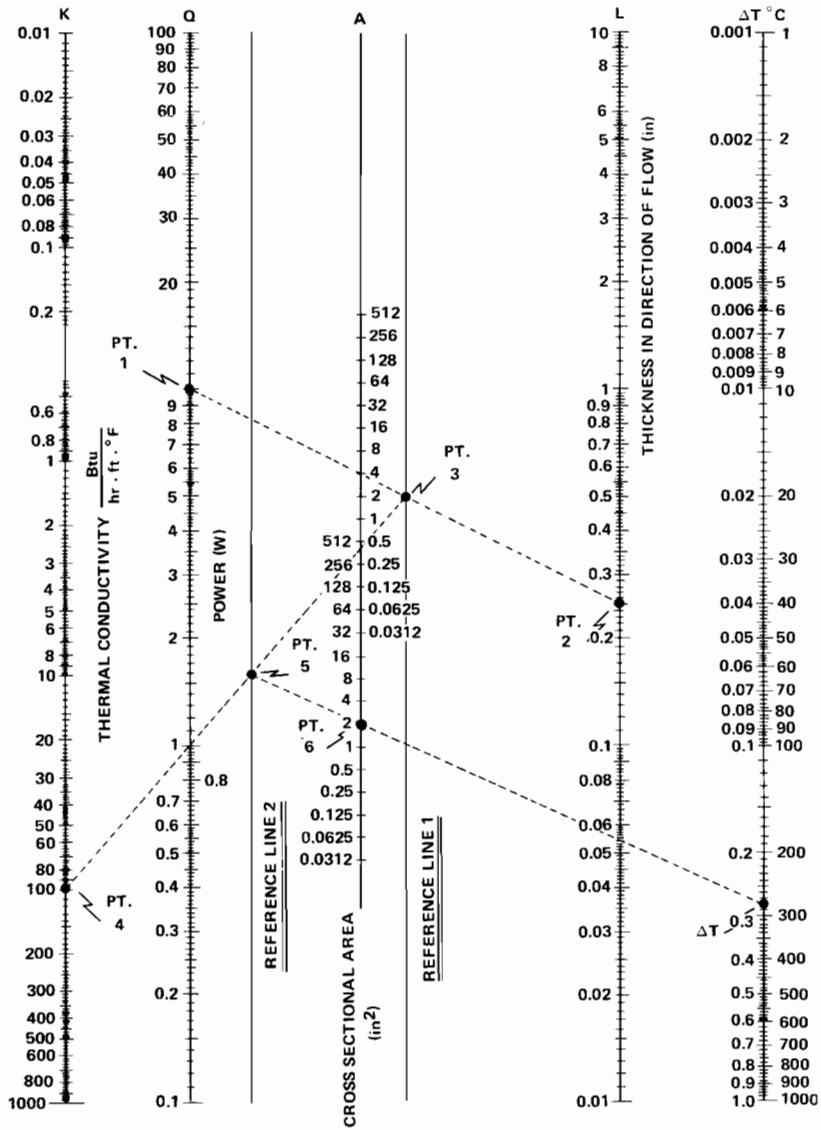

- NOTES: 1. Nomograph incorporates conversion of units as indicated.
2. To determine ΔT , first use numbers for A and ΔT on the left side of the respective scales. If a $\Delta T > 1$ is indicated (off ΔT scale), use A scale on the right side of the A scale and read ΔT on the right side of the ΔT scale.
3. Multiplication by 10 may be used for the Q, L, K, and A scales.

Q or L X 10 increases ΔT by 10.
 K or A X 10 decreases ΔT by 10.

Figure 5.4. Nomograph A – Conductivity of Materials

As seen in Figure 5.4, the ΔT of the example is:

$$\Delta T = 0.285^{\circ}\text{C}$$

Note the ΔT calculated is the temperature gradient from one surface of the plate to the other surface of the plate. To apply this for a device whose thermal gradient from its junction to its case is known requires knowledge of the interface between the package and the heat-sink surface ($R_{\theta CS}$).

$$R_{\theta JA} = R_{\theta JC} + R_{\theta CS} + R_{\theta SA}$$

The interface ($R_{\theta CS}$) is the prime thermal barrier. Failure to move the maximum amount of heat across this barrier can be detrimental, even to the best thermal design. The thermal resistance across this or any other interface is a function of the cross-sectional area, surface finishes, surface flatness, contact pressure of the surfaces, and thermal conductivity of any fillers, if used. To minimize this effect:

- 1) Maintain surfaces as flat and smooth as possible.
- 2) Maximize surface contact areas.
- 3) Use thermal contact fluids, where practical.
- 4) Torque mounting bolts or screws to manufacturer's recommended values, where applicable.

The graph shown in Figure 5.5 illustrates the effect pressure and various surface finishes have on the contact thermal impedance.

5.2.2 Convection Radiation

The contact of any fluid with a hotter surface reduces the density of the fluid and causes it to rise. Circulation caused by this phenomenon is known as free or natural convection. The amount of energy radiated by a body is dependent upon its temperature, emissivity, and total surface area. Heat transfer by these two means is not as easily expressed as that previously discussed for conductive cooling, and is often done empirically. A reasonably accurate first-order approximation can be calculated using the following approach.

The basic conditions for convection-cooled heat sinks are:

1. Use a heat sink that affords maximum surface area for a given volume.
2. Use a material finish whose emissive properties are as large as the structural, economical, and electrical limitations will allow.
3. Use heat-sink material with as high a thermal conductivity as system requirements allow.

CURVE	FINISH (RMS)	CUTS	CONDITION
A	1000 SHAPED	PARALLEL	RUSTED
B	1000 SHAPED	PARALLEL	CLEAN
C	1000 SHAPED	PERPENDICULAR	CLEAN
D	125 MILLED	PARALLEL	RUSTED
E	125 MILLED	PARALLEL	CLEAN
F	63 SHAPED	PERPENDICULAR	CLEAN
G	63 SHAPED	PARALLEL	CLEAN
H	4 LAPPED	PARALLEL	CLEAN

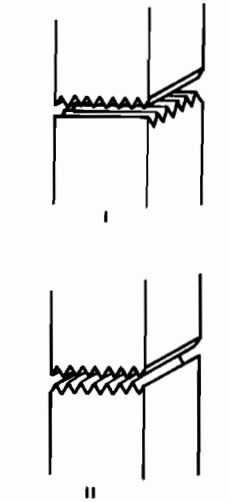
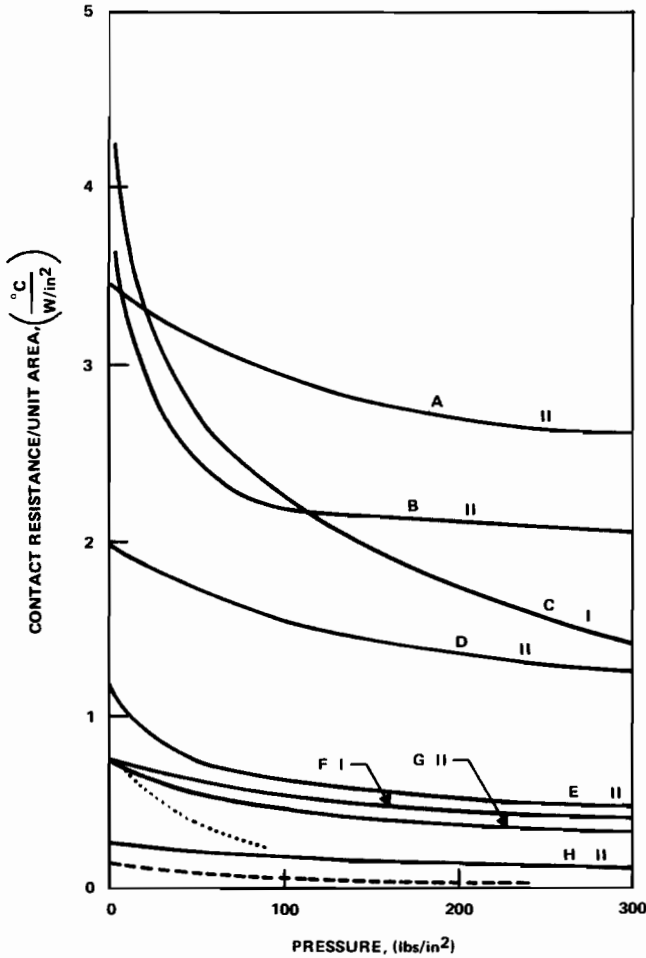

VALUES OF $\frac{1}{h_c}$ BASED ON
 $K = 140 \frac{\text{W/in}^2}{^{\circ}\text{C/in}}$

- 0.18% G STEEL @ 100°C
- - - SMOOTH ALUMINUM
- ROUGH ALUMINUM

Figure 5.5. Contact Thermal Impedance as a Function of Contact Pressure
 (From Guidelines to Semiconductor Thermal Management, Joseph P. Laffin, IERC)

4. In natural convection, mount heat sinks such that maximum length of extrusions (fins) are in the vertical plane.
5. Mount lowest power or highest thermally sensitive devices on lowest location of heat sinks common to other power devices. (Heat rises.)
6. Provide proper ventilation such that natural convection currents are not restricted.
7. Ensure location of the heat sink is such that it radiates thermal energy, not absorbs it from other bodies.

The basic purpose of designing a heat sink is to produce a heat sink that exhibits a thermal resistance ($R_{\theta SA}$) required for the application.

$$R_{\theta SA} = \frac{1}{A \eta (F_C h_C + \epsilon H_r)} \text{ (}^\circ\text{C/W)}$$

where:

A = surface area of heat sink

η = effectiveness of heat sink

F_C = convective correction factor

h_C = convection heat transfer coefficient

ϵ = emissivity

H_r = normalized radiation heat transfer coefficient

The tables and graphs shown in the following text are used to determine the various unknowns above and finally the thermal resistance of the heat-sink design itself. The use of these tables can best be demonstrated through an example.

Given:

$$P_D = 2.5 \text{ W}$$

Package = TO-220
 $(R_{\theta JC} = 4^\circ\text{C/W})$

$$T_J \text{ max} = 150^\circ\text{C}$$

$$T_A = 70^\circ\text{C}$$

Heat sink:

Size: 2" × 2" × 1/8"

Material: Anodized Al

Mounting: Bare ($R_{\theta CS} = 3^\circ\text{C/W}$)

Position: Horizontal on PC board surface

Calculate required $R_{\theta SA}$ of heat sink

$$P_D = \frac{T_J - T_A}{R_{\theta JC} + R_{\theta CS} + R_{\theta SA}}$$

$$R_{\theta SA} = \frac{T_J - T_A}{P_D} - R_{\theta JC} - R_{\theta CS}$$

$$R_{\theta SA} = \frac{80^\circ\text{C}}{2.5\text{ W}} - 4^\circ\text{C/W} - 3^\circ\text{C/W}$$

$$R_{\theta SA} = 25^\circ\text{C/W}$$

Determine Significant Dimension L From Table 5.8

$$L = \frac{2 \times 2}{2 + 2}$$

$$L = 1''$$

Table 5.8. Significant Dimension L for Convection Thermal Resistance

Surface	Significant Dimension L	
	Position	L (inch)
Rectangular Plane	Vertical	Height (2 ft max)
	Horizontal	$\frac{\text{Length} \times \text{Width}}{\text{Length} + \text{Width}}$
Circular Plane	Vertical	$\frac{\pi}{\text{Diameter}}$

Find the Convective Heat Transfer Coefficient from Figure 5.6

$$T_S = T_J - (R_{\theta JC} + R_{\theta CS}) P_D$$

$$T_S = 150^\circ\text{C} - (4^\circ\text{C/W} + 3^\circ\text{C/W}) 2.5\text{ W}$$

$$T_S = 150^\circ\text{C} - 17.5^\circ\text{C}$$

$$T_S = 132.5^\circ\text{C}$$

$$T_S - T_A = 62.5^\circ\text{C}$$

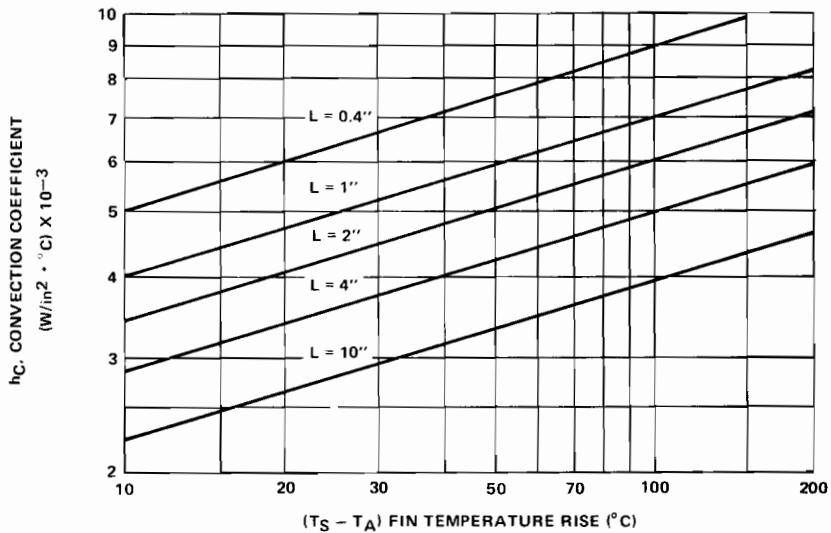

Figure 5.6. Convection Coefficient h_C

From Figure 5.6:

$$h_C = 6.25 \times 10^{-3} \frac{W}{in^2 \cdot ^\circ C}$$

Like the significant dimension L , the convective correction factor F_C is dependent upon the shape and mounting plane of the heat sink.

Determine F_C from Table 5.9

$$F_C = 0.9$$

Table 5.9. Corrective Factor for Convection Thermal Resistance

Position	Vertical Plane	Horizontal Plane	
		Both Surfaces Exposed	Top Only Exposed
F_C	1.0	1.35	0.9

The normalized radiation heat transfer coefficient (H_r) is dependent upon thermal gradient across the heat sink ($T_S - T_A$) and the ambient temperature.

Determine H_r from Figure 5.7

$$H_r = 0.77 \times 10^{-2} \frac{W}{in^2 \cdot ^\circ C}$$

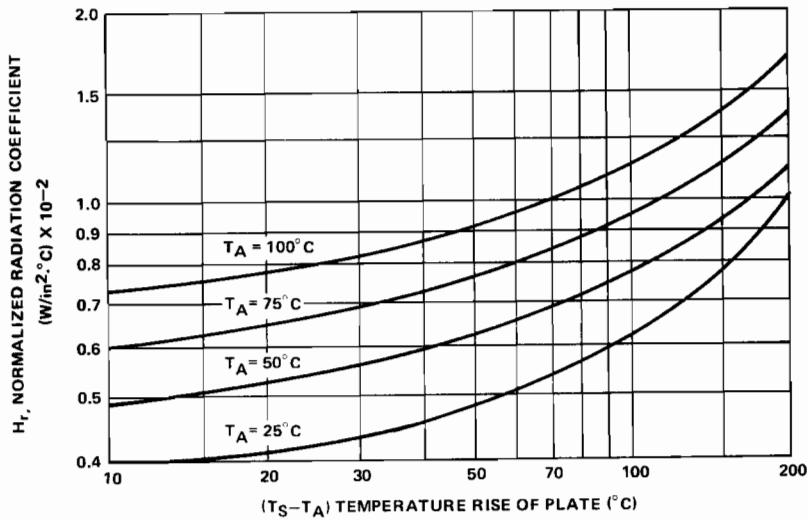

Figure 5.7. Normalized Heat Transfer Coefficient H_r

The emissivity is determined by the heat-sink surface and is the ratio of emissive power of a given body to the ideal "black-body" equivalent of the surface.

Determine Emissivity (ϵ) from Table 5.10

The heat-sink material being anodized aluminum:

$$\epsilon = 0.8$$

Table 5.10. Emissivities for Common Surfaces

Finish	ϵ
Aluminum - Anodized	0.7 - 0.9
Aluminum - Polished	0.15
Aluminum - With Alodine	0.05
Copper - Polished	0.07
Copper - Oxidized	0.7
Iron - Snow-White Enamel	0.9
Iron - Snow-White Varnish	0.9
Iron - Black Shiny Lacquer	0.875
Tinned Iron-Black Shiny Shellac	0.821
Black-Matte Shellac	0.91
Black Lacquer	0.8 -0.95
Flat-Black Lacquer	0.96-0.98
White Lacquer	0.80-0.95
Oil Paint (All colors)	0.92-0.96
Insulube 448	0.91

Find Heat-sink Efficiency η from Nomograph B.

1. Calculate h_T

$$h_T = F_C h_C + \epsilon H_r$$

$$h_T = (0.9 \times 6.25 + 0.8 \times 7.7) \times 10^{-3} \left(\frac{W}{in^2 \text{ } ^\circ C} \right)$$

$$h_T = 1.17 \times 10^{-2} \left(\frac{W}{in^2 \text{ } ^\circ C} \right)$$

Locate h_T on the nomograph in Figure 5.9.

2. Plot the fin thickness of the heat sink.
3. Draw a line from point 1 through point 2, extending through the scale α . The intersection of this line and the scale α , determined α l.
4. Determine factor D for the heat sink, using Figure 5.8.

$$D = \sqrt{\frac{2 \times 2}{\pi}}$$

$$D = 1.13$$

5. Project a line from point 4 through point 3 and intersect the η scale. The intersection of this line and the scale determines the value of η .

From Figure 5.9:

$$\eta > 94\%$$

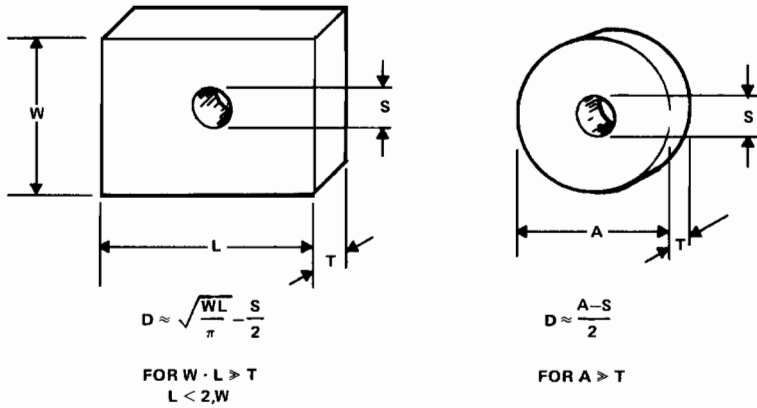

Figure 5.8. Determining "D" for Use with Figure 5.10

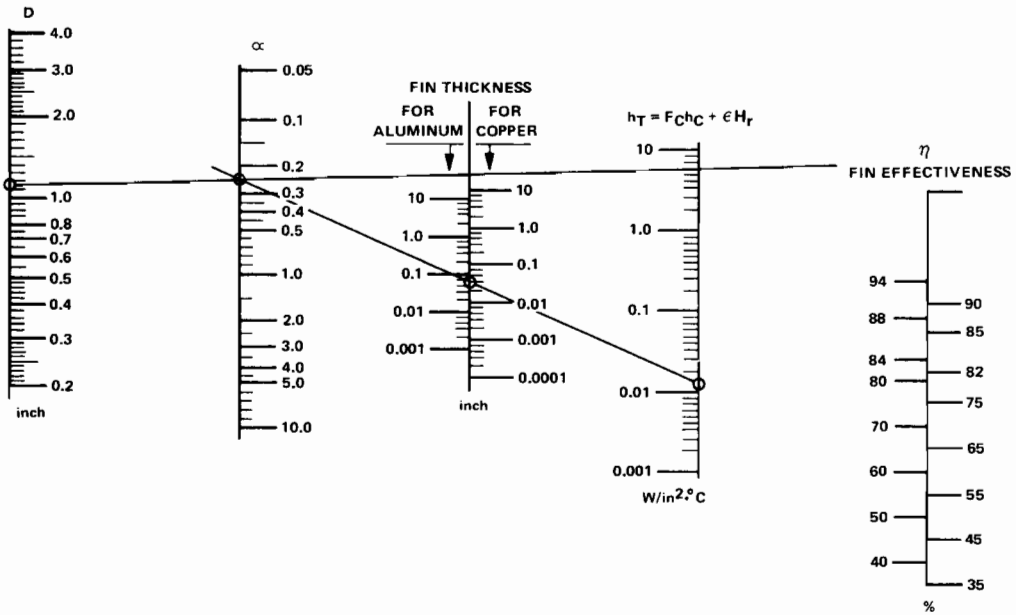

Figure 5.9. Nomograph B – Fin Effectiveness

6. Calculate $R_{\theta SA}$: (consider $\eta = 1$)

$$R_{\theta SA} = \frac{1}{A \eta (F_C h_C + \epsilon H_r)} \left(\frac{^{\circ}\text{C}}{\text{W}} \right)$$

$$R_{\theta SA} = \frac{1}{(2'' \times 2'') (1.0) \left(1.17 \times 10^{-2} \frac{\text{W}}{\text{in}^2 \text{ } ^{\circ}\text{C}} \right)}$$

$$R_{\theta SA} = \frac{1}{4.7 \times 10^{-2} \frac{\text{W}}{^{\circ}\text{C}}}$$

$$\boxed{R_{\theta SA} = 21.3^{\circ}\text{C/W}}$$

Comparing the required thermal resistance to the designed heat sink:

$$R_{\theta SA} \text{ (design)} = 21.3^{\circ}\text{C/W}$$

$$R_{\theta SA} \text{ (required)} = 25^{\circ}\text{C/W}$$

This is satisfactory.

6

Layout Guidelines

As implied in the previous sections, the layout and component orientation play an important, but often overlooked, role in the overall performance of the regulator. The importance of this role depends upon such things as the amount of power being regulated, the type of regulator, the overall regulator circuit complexity, and the environment in which the regulator resides. The general layout rules, remote voltage sensing, and component layout guide lines are discussed in the following text.

6.1 GENERAL

Most integrated circuit regulators employ wide-band transistors in their construction to optimize their response. These devices must be compensated to ensure stable closed-loop operation. Their compensation can be upset easily by external stray capacitance and line inductance of an improper layout. For this reason, circuit lead lengths should be held to a minimum. Lead lengths associated with external compensation or pass transistor elements are of primary concern. These components especially, should be located as close as possible to the regulator control circuit.

6.2 CURRENT PATHS

In addition to a regulator's susceptibility to spurious oscillation, the layout of the regulator also affects the accuracy and performance of the circuit.

6.2.1 Input Ground Loop

Improper placement of the input capacitor can induce unwanted ripple on the output voltage. Care should be taken to ensure that currents flowing in the input circuit are not experienced by the ground line common with the load return line. This results in an error voltage developed by the peak currents of the filter capacitor flowing through the line resistance of the load return line. See Figure 6.1 for an illustration of this effect.

6.2.2 Output Ground Loop

Similar to the problem discussed on the input, excessive lead length in the ground return line of the output results in additional error. If the ground line of the load circuit is located such that it experiences the current flowing in the load, error equivalent to the load current times the line resistance ($R2' + R3'$) will be introduced to the output voltage.

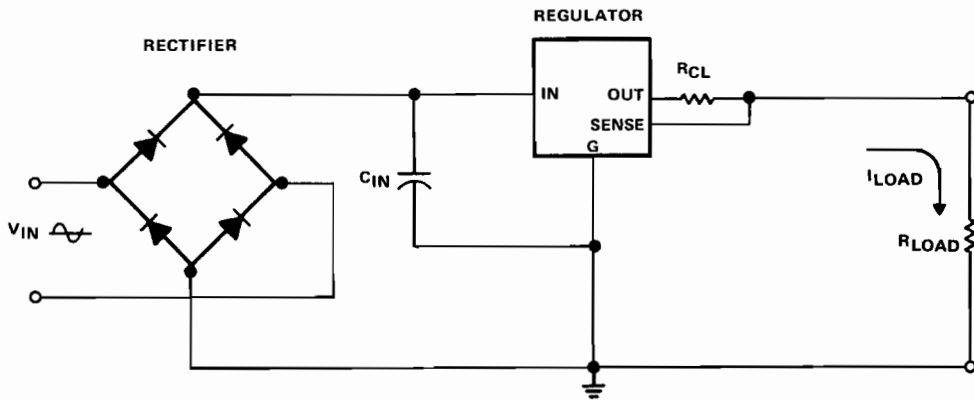

(a) TYPICAL LAYOUT

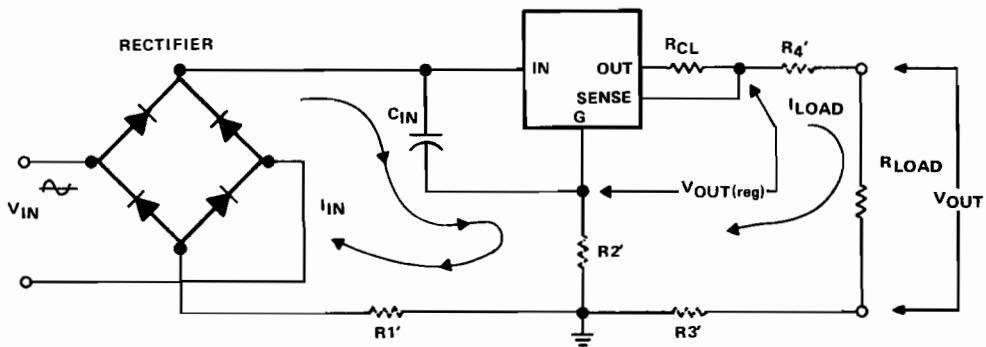

(b) LAYOUT ERROR CONTRIBUTIONS

Figure 6.1. Circuit Layout Showing Error Contributions

6.2.3 Remote Voltage Sense

The voltage regulator should be located as close as practical to the load if the output voltage sense circuitry is internal to the regulator's control device. Excessive lead length will result in an error voltage developed across the distributed line resistance (R_4') as it experiences the current being delivered to the load (I_{LOAD}).

$$V_{OUT} = V_{OUT (reg)} - (R_2' + R_3' + R_4') I_{LOAD} + R_2' I_{IN}$$

$$ERROR = I_{LOAD} (R_2' + R_3' + R_4') - I_{IN} R_2'$$

If the voltage sense is available externally, the effect of the line resistance can be minimized. By referring the low-current external voltage sense input to the load, losses in the output line ($R_4' \times I_{LOAD}$) are compensated for. Since the current in the sense line is very small, error introduced by its line resistance is negligible.

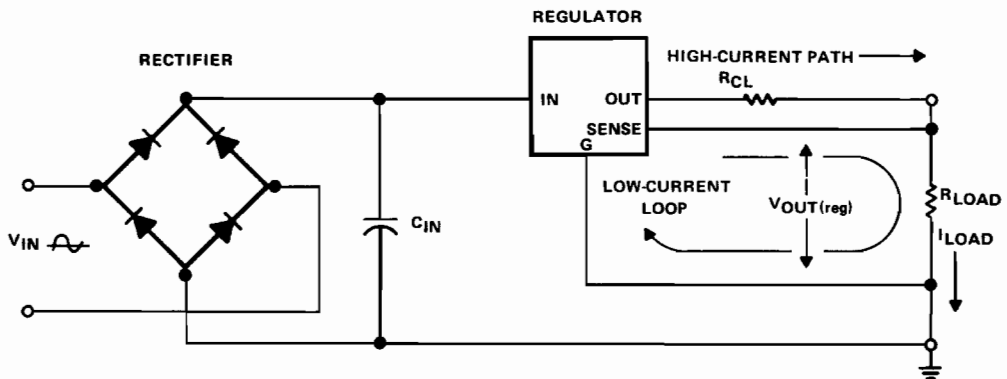

Figure 6.2. Proper Regulator Layout

6.3 THERMAL PROFILE

All semiconductor devices are affected by temperature; therefore, care should be taken in the placement of these devices such that their thermal properties are not additive. This is especially important where external pass transistors or reference elements are concerned.

7

Input Filter Design

Where the power origin is an ac source, the transformer, rectifier, and input filter design are as important as the regulator design itself so far as total system performance is concerned. This section presents input supply and filter design information sufficient to design a basic capacitor-rectifier input supply.

7.1 TRANSFORMER/RECTIFIER CONFIGURATION

The input supply consists of three basic sections: (1) input transformer, (2) rectifier, and (3) filter as shown in Figure 7.1.

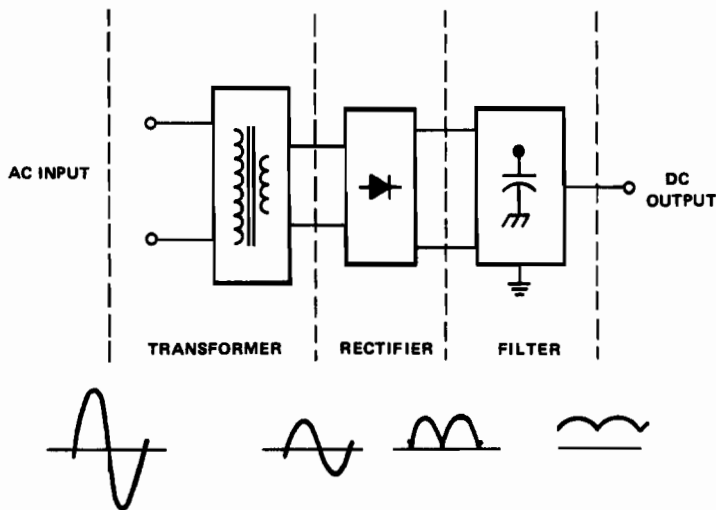

Figure 7.1. Input Supply

The first two sections, the transformer and the rectifier, are partially dependent upon each other as one's structure depends on that of the other. The most common transformer configurations and their associated rectifier circuits are illustrated in Figure 7.2.

The particular configuration used depends on the application. The half-wave circuit [Figure 7.2(a)] is used in low-current applications, since the single rectifier diode experiences the total load current and the conversion efficiency is less than 50%. The full-wave configurations

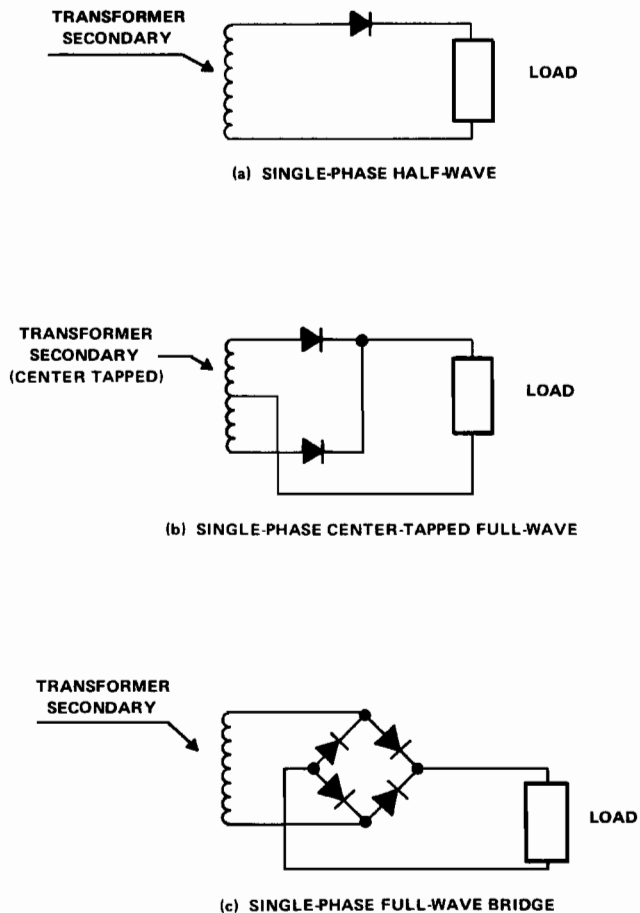

Figure 7.2. Input Supply Transformer/Rectifier Configurations

[Figures 7.2(b) and 7.2(c)] are used for higher current applications with the center-tapped version [Figure 7.2(b)] restricted primarily to low-voltage applications. The characteristic output voltage waveforms of these configurations are illustrated in Figure 7.3.

Before the design of the input supply and its associated filter can be initiated, the voltage, current, and ripple requirements of its load must be fully defined. The load, as far as the input supply is concerned, is the regulator control circuit. Therefore, the input requirements of the regulator itself become the governing conditions.

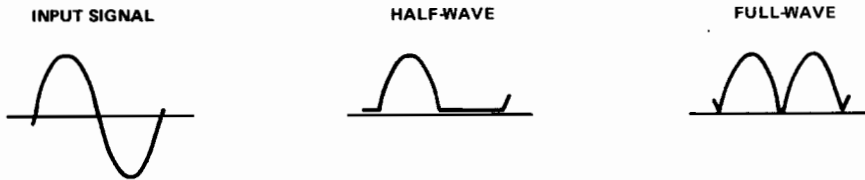

Figure 7.3. Rectifier Output-Voltage Waveforms

Input Supply	Regulator Control Circuit
$I_{OUT\ max} =$	$I_{IN} + I_{CC\ (reg)} \approx I_{OUT}$
$I_{OUT\ min} =$	$I_{CC\ (reg)}$
$V_{OUT\ max} <$	$MAX\ V_{IN}$
$V_{OUT\ min} \geq$	$V_{IN\ min} > V_{OUT} + V_{DIFF\ min}$
$r_f \leq$	$\frac{V_{in}}{V_{IN}} = \frac{V_{out} \cdot RR}{V_{IN}}$

Because the input requirements of the regulator control circuit govern the input supply and filter design, it is easiest to work backwards from the load to the transformer primary.

7.2 CAPACITOR INPUT FILTER

The most practical approach to a capacitor-input filter design remains the graphical approach presented by Schade in 1943. The curves shown in Figures 7.4 through 7.7 contain all of the design information required for full-wave and half-wave rectified circuits.

Figures 7.4 and 7.5 show the relation of dc output voltage developed (V_C) to the applied peak input voltage ($V_{(PK)}$) as a function of ωCR_L for half-wave and full-wave rectified signals respectively. For a full-wave rectified application, the voltage reduction is less than 10% for $\omega CR_L > 10$ and $R_S/R_L < 0.5\%$. As illustrated, the voltage reduction decreases as ωCR_L increases or the R_S/R_L ratio decreases. Minimizing the reduction rate, contrary to initial impressions, may prove to be detrimental to the optimum circuit design. Further reduction requires a reduction in the series to load resistance ratio (R_S/R_L) for any given ωCR_L . This will result in a higher peak-to-average current ratio through the rectifier diodes. (See Figure 7.6.) In addition and probably of more concern, this increases the surge current experienced by the rectifier diodes during turn-on of the supply. Realize the surge current is limited only by the series resistance R_S :

$$I_{SURGE} = \frac{V_{SEC\ (PK)}}{R_S}$$

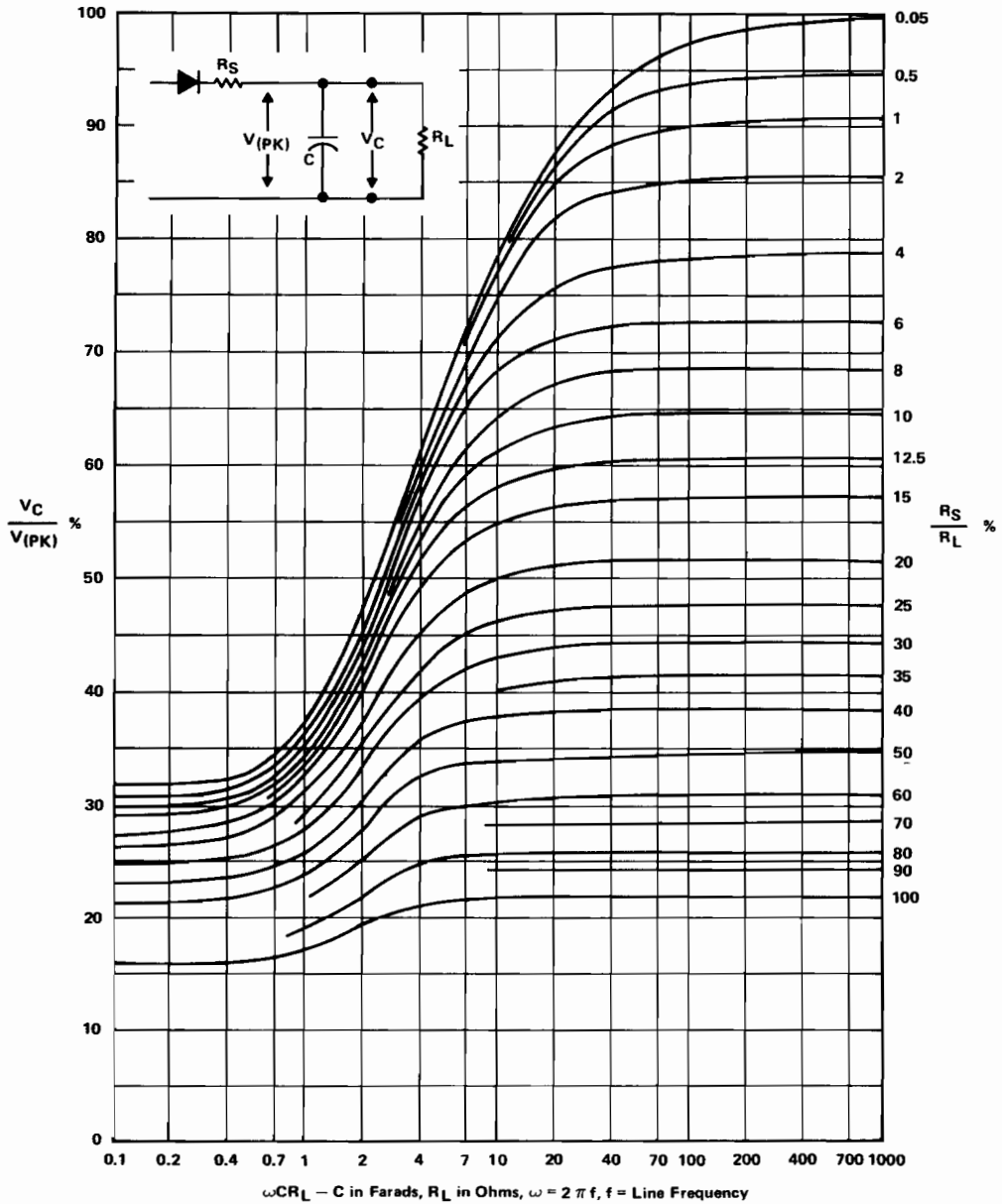

Figure 7.4. Relation of Applied Alternating Peak Voltage to Direct Output Voltage in Half-Wave Capacitor-Input Circuits
 (From O. H. Schade, Proc. IRE, Vol. 31, p. 343, 1943)

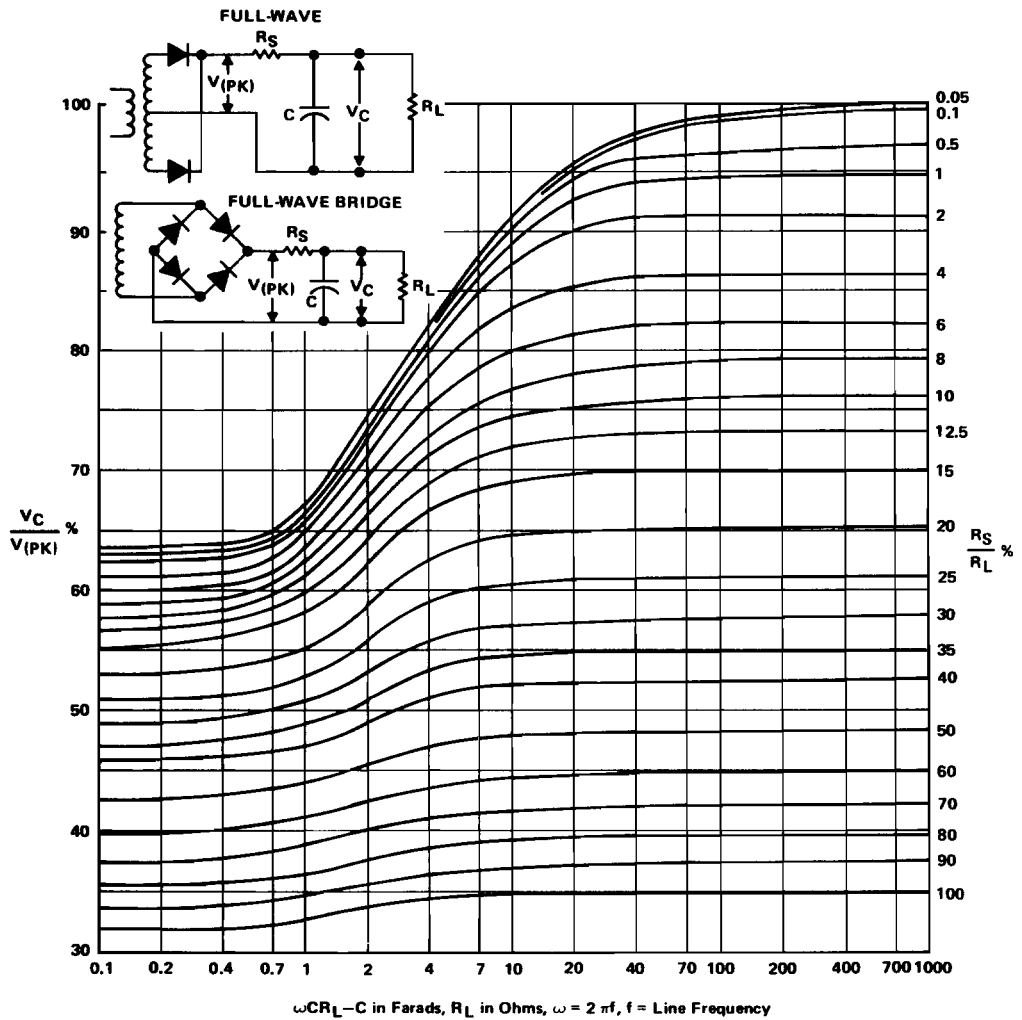
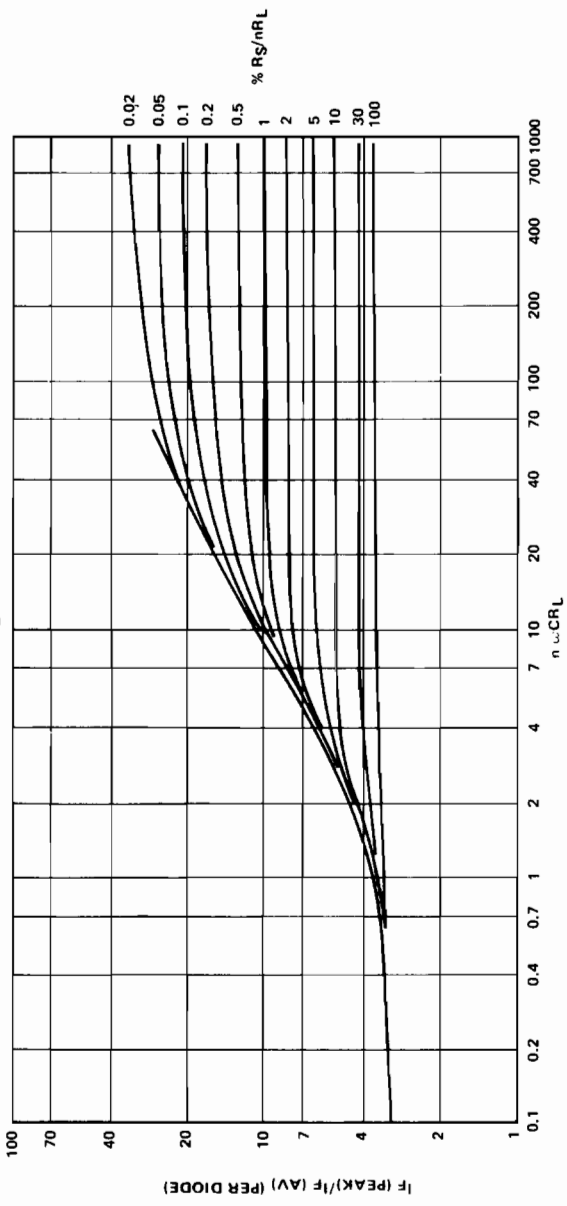
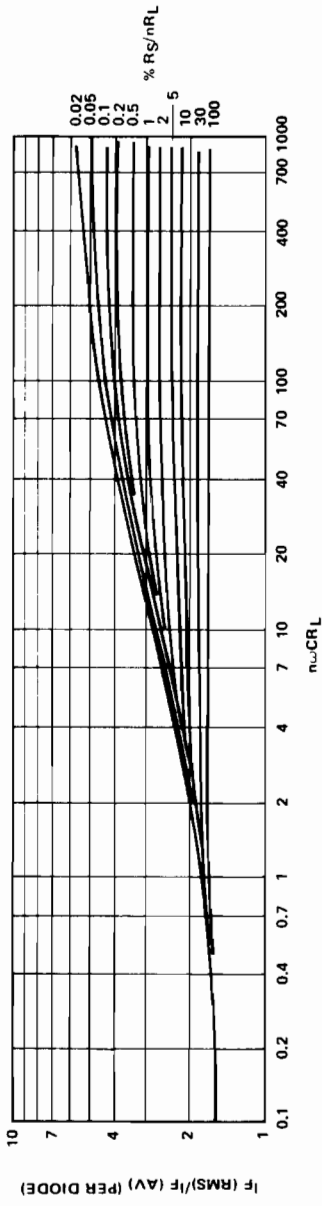

Figure 7.5. Relation of Applied Alternating Peak Voltage to Direct Output Voltage in Full-Wave Capacitor-Input Circuits (From O. H. Schade, Proc. IRE, Vol. 31, p. 344, 1943)



$n = 1$ For Half-Wave Single-Phase Rectifier Circuits
 $n = 2$ For Full-Wave Single-Phase Rectifier Circuits
 $\omega = 2\pi f$ where $f =$ Line Frequency
 C in Farads
 R_L in Ohms
 $R_S =$ RMS Equivalent Source Resistance

Figure 7.6. Relation of RMS and Peak to Average Diode Current in Capacitor Input Circuits
 (From O. H. Schade, Proc. IRE, Vol. 31, p. 345, 1943)

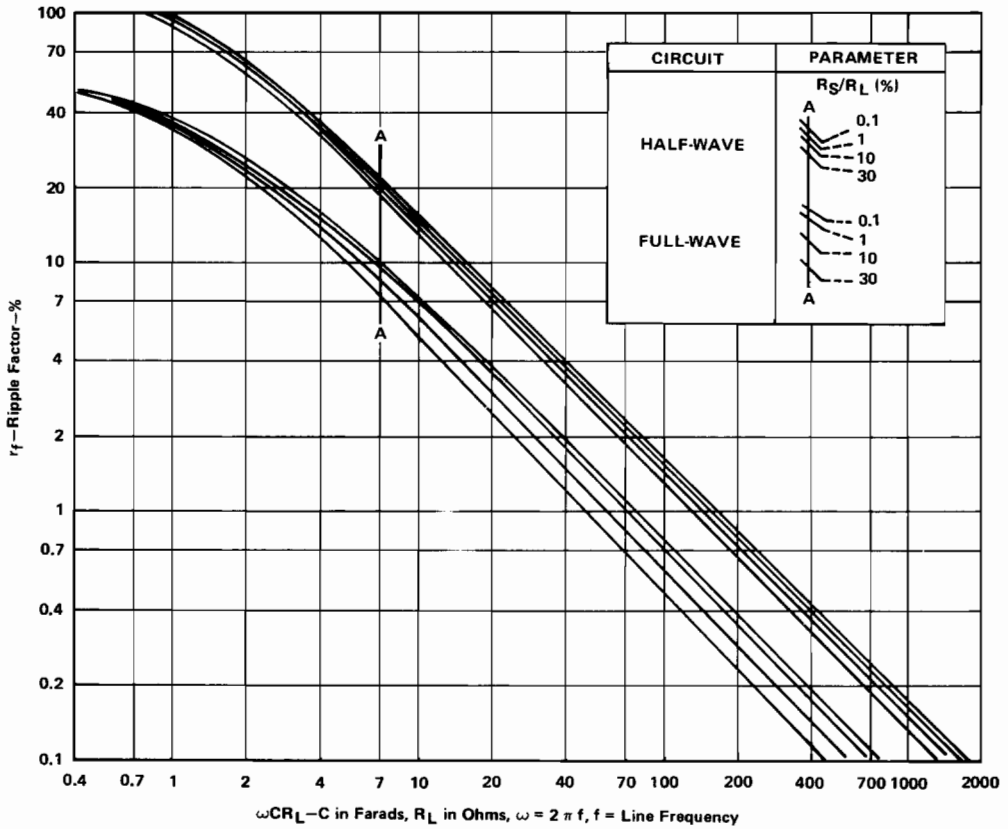

Figure 7.7. Root-Mean-Square Ripple Voltage for Capacitor-Input Circuits
 (From O. H. Schade, Proc. IRE, Vol. 31, p. 346, 1943)

In order to control the surge current, additional resistance is often required in series with each rectifier. It is evident that a compromise must be made between the voltage reduction and the rectifier current ratings.

The maximum instantaneous surge current is $V_{(PK)}/R_S$. The time constant (τ) of capacitor C is:

$$\tau \cong R_S C$$

As a rule of thumb, the surge current will not damage the rectifier diode if

$$I_{SURGE} < I_{F(SURGE) \max} \text{ and } \tau < 8.3 \text{ ms}$$

Figure 7.7 shows the relationship of the ripple factor r_f , ωCR_L , and R_S/R_L . The ripple factor (r_f) is the ratio of the RMS value of the ripple component of the output voltage expressed as a percent of the absolute dc output voltage. Expressed in terms of the input requirements of the regulator control circuit:

$$r_f = \frac{V_{in}}{V_{IN}} \times 100\%$$

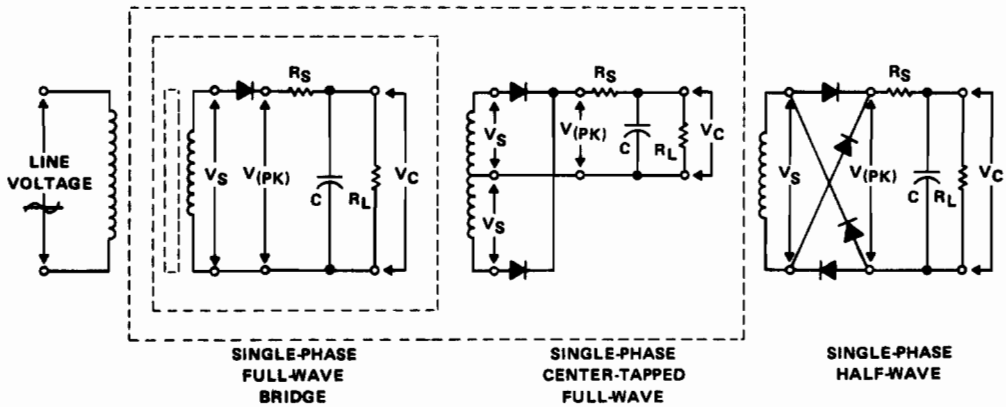

Figure 7.8. Input Filter Design

7.3 DESIGN PROCEDURE

1. Define the known requirements of the regulator control circuit.

$$V_C = V_{IN} \text{ (reg)}$$

$$r_f = \frac{V_{in}}{V_{IN}}$$

$$I_{OUT} = I_{LOAD} \text{ (reg)}$$

f = frequency of line voltage

2. Determine V_C . The choice of V_C may be random or it may be influenced by the regulator control circuits recommended V_{IN} . The first approximation of the acceptance range of V_C is defined by:

$V_C \text{ max} <$ The maximum input voltage of the regulator control circuit minus the peak ripple voltage of the filter network.

$V_C \text{ min} >$ The minimum input voltage of the regulator control circuit plus the peak ripple voltage of the filter network.

If a particular value of V_C within the defined range is not prevalent, choose a value for V_C midway between the limits.

3. Set $V_{(PK)}$ at or near the $V_C(\text{max})$ limit allowing for input line variations.
4. Calculate the acceptable ripple factor (r_f).

$$r_f = \frac{V_{in}}{V_{IN}}$$

where:

V_{IN} = The dc input voltage of the regulator control circuit.

V_{in} = The RMS value of the ripple component of the input voltage allowed on the input of the regulator control circuit.

$$V_{in} = \frac{V_{in (p-p)}}{2\sqrt{2}}$$

$V_{in (p-p)}$ = The peak-to-peak value of the ripple component of the input voltage.

$$V_{in (p-p)} = V_{out (p-p)} \cdot RR$$

$V_{out (p-p)}$ = The peak-to-peak value of the ripple component of the output voltage.

RR = The ripple rejection factor of the regulator control circuit.

$$\therefore r_f = \frac{V_{out (p-p)} \cdot RR}{V_{IN} \cdot 2\sqrt{2}}$$

5. Calculate the voltage reduction of the filter circuit.

$$\text{Voltage Reduction} = \frac{V_{IN}}{V_{(PK)}}$$

6. From Figure 7.7, determine the range of ωCR_L for R_S/R_L equal to 0.1% to 30%.

7. From Figure 7.4 or 7.5, as applicable, narrow the range of R_S/R_L for the voltage reduction value calculated above.
8. With the tightened range of R_S/R_L , refer again to Figure 7.7 to further define the acceptable range of ωCR_L .

Several iterations reviewing Figures 7.4 or 7.5, and 7.7 may be necessary to define an exact solution for R_S/R_L and ωCR_L that satisfies the graphs of Figures 7.4, 7.5, and 7.7.

9. Once ωCR_L and R_S/R_L have been determined, calculate R_L :

$$R_L = \frac{V_{IN}(\text{reg})}{I_{LOAD}(\text{reg})}$$

10. Calculate ω :

$$\omega = 2 \pi f$$

11. Determine C:

$$C = \frac{\omega CR_L}{\omega R_L}$$

12. Find the allowable series resistance.

$$R_S = \frac{R_S}{R_L} \cdot R_L$$

13. Determine the peak and RMS forward current to be experienced by the rectifier diodes from Figure 7.6.

where:

$$I_F(\text{AV}) = I_{LOAD}(\text{reg}) \text{ (for half-wave circuits)}$$

$$I_F(\text{AV}) = \frac{1}{2} I_{LOAD}(\text{reg}) \text{ (for full-wave circuits)}$$

14. Determine the surge current required to be sustained by rectifier diodes.

$$I_{SURGE} = \frac{V_{(PK)}}{R_S}$$

15. Determine the peak inverse voltage of the rectifier circuit.

$$PIV = V_{(PK)} \text{ for the bridge rectifier circuit}$$

$$PIV = 2 V_{(PK)} \text{ for all other rectifier circuits}$$

16. Verify that the voltage reduction of the filter ($V_{(PK)}$) and the ripple voltage under worst-case conditions result in an output voltage (V_C) that is satisfactory with the operating input voltage range of the regulator control circuit.

$$[V_{(PK)} + \Delta V_{LINE}] K_F + V_{in (pk)} \leq V_{IN \text{ max (regulator)}}$$

$$[V_{(PK)} - \Delta V_{LINE}] K_F - V_{in (pk)} \geq V_{IN \text{ min (regulator)}}$$

where:

$$\Delta V_{LINE} = \text{variation in } V_{(PK)} \text{ caused by line voltage variation}$$

$$K_F = \text{voltage reduction of the filter section expressed in \%}$$

$$V_{in (pk)} = \text{peak value of the ripple component of the input voltage}$$

17. Calculate the required secondary voltage (RMS) of the transformer:

$$V_{SEC (RMS)} = \frac{V_{(PK)} + V_{RECT}}{\sqrt{2}}$$

where:

$$V_{RECT} = 2 V_F \text{ (rectifier) for full-wave bridge circuit } (\approx 2 V)$$

$$V_{RECT} = 1 V_F \text{ (rectifier) for other circuits } (\approx 1 V)$$

18. Find the resistance of the secondary:

- R_S is the total resistance of the transformer secondary and any additional external resistance in the input supply circuit.

19. The secondary RMS current is:

- Half-wave and full-wave circuit $\equiv I_{F(RMS)}^*$
- Full-wave bridge circuit $\equiv \sqrt{2} I_{F(RMS)}^*$

20. Determine the transformer's VA rating.

- Half-wave circuit $\equiv V_{SEC(RMS)} I_{F(RMS)}^*$
- Full-wave circuit $\equiv 2 V_{SEC(RMS)} I_{F(RMS)}^*$
- Full-wave bridge circuit $\equiv \sqrt{2} V_{SEC(RMS)} I_{F(RMS)}^*$

* $I_{F(RMS)}$ is the RMS forward current of the rectifier found in step 13.

Example

Given: $\mu A7805C$ is the regulator circuit

$$I_{LOAD} = 1 \text{ amp}$$

$$V_{OUT(\text{ripple})} \leq 3 \text{ mV (p-p)}$$

$$f_{LINE} = 60 \text{ Hz}$$

From: $\mu A7805C$ specifications

$$V_{IN \text{ min}} = 7 \text{ V}$$

$$V_{IN \text{ max}} = 25 \text{ V}$$

$$\text{Ripple Rejection} = 62 \text{ dB} \approx 1000$$

Choose full-wave bridge rectifier circuit

- $V_{in \text{ (p-p)}} \approx 3 \text{ mV} \cdot 1000 = 3 \text{ V}$

$$V_{in \text{ (pk)}} \approx 1.5 \text{ V}$$

$$\boxed{V_{in} \approx 1.1 \text{ V}}$$

- $V_{IN \text{ min}} + V_{in \text{ (pk)}} < V_C < V_{IN \text{ max}} - V_{in \text{ (pk)}}$

$$7 \text{ V} + 1.5 \text{ V} < V_C < 25 \text{ V} - 1.5 \text{ V}$$

$$8.5 \text{ V} < V_C < 23.5 \text{ V}$$

$$\boxed{\text{set } V_C = 16 \text{ V}}$$

$$\boxed{\text{set } V_{(PK)} = 20 \text{ V}} \quad (23.5 - 10\% \text{ line variation})$$

- $r_f = \frac{1.1 \text{ V}}{16 \text{ V}} \times 100\%$

$$\boxed{r_f = 6.25\%}$$

- $\text{Voltage Reduction} = \frac{16 \text{ V}}{20 \text{ V}} \times 100\%$

$$\boxed{\text{Voltage Reduction} = 80\%}$$

- from Figure 7.7:
 $7.3 < \omega CR_L < 25$ for $0.1\% < R_S/R_L < 30\%$

- from Figure 7.5:

$$5\% < R_S/R_L < 7\% \text{ for } \frac{V_C}{V_{(PK)}} = 80\%$$

referring back to Figure 7.7

$$\boxed{\text{for } R_S/R_L = 6\%} \quad \boxed{\omega CR_L = 9.3}$$

- $R_L = \frac{16 \text{ V}}{1 \text{ A}}$

$$\boxed{R_L = 16 \Omega}$$

- $\omega = 2\pi(60)$

$$\boxed{\omega = 377 \frac{\text{rad}}{\text{s}}}$$

- $C = \frac{9.3}{16 \times 377}$

$$\boxed{C = 1500 \mu\text{F}}$$

- $R_S = (6\%)(16 \Omega)$

$$\boxed{R_S = 0.96 \Omega}$$

- $I_F(\text{AV}) = \left(\frac{1}{2}\right)(1\text{A}) = 0.5 \text{ A}$

from Figure 7.6:

$$I_F(\text{RMS})/I_F(\text{AV}) = 2.1$$

$$\boxed{I_F(\text{RMS}) = 1.05 \text{ A}}$$

$$I_F(\text{PK})/I_F(\text{AV}) = 6$$

$$\boxed{I_F(\text{PK}) = 3 \text{ A}}$$

- $I_{\text{SURGE}} = \frac{20 \text{ V}}{0.96 \Omega}$

$$\boxed{I_{\text{SURGE}} = 20.8 \text{ A}}$$

- $PIV = 2 (20 \text{ V})$

$$PIV = 40 \text{ V}$$

- $(20 \text{ V} + 2 \text{ V}) (0.80) + 1.5 \text{ V} \leq 25 \text{ V}$

$$19.5 \text{ V} < 25 \text{ V}$$

$$(20 \text{ V} - 2 \text{ V}) (0.80) - 1.5 \text{ V} \geq 8 \text{ V}$$

$$12.9 \text{ V} > 8 \text{ V}$$

- $V_S = \frac{20 \text{ V} + 2 \text{ V}}{\sqrt{2}}$

$$V_S = 15.6 \text{ V}$$

- $R_{\text{SECONDARY}} < R_S + 2 R_{S (\text{rect})} + R_{S (\text{cap})}$

- $I_{\text{SEC (PK)}} = \sqrt{2} (1.05 \text{ A})$

$$I_{\text{SEC (PK)}} = 1.48 \text{ A}$$

- $VA \text{ rating} = (15.6 \text{ V}) (1.05 \text{ A}) \sqrt{2}$

$$VA \text{ rating} = 23.2 \text{ VA}$$

Part 2

GLOSSARY

VOLTAGE-REGULATOR TERMS AND DEFINITIONS

SERIES REGULATORS

Input Regulation

The change in output voltage, often expressed as a percentage of output voltage, for a change in input voltage from one level to another level.

NOTE: Sometimes this characteristic is normalized with respect to the input voltage change.

Ripple Rejection

The ratio of the peak-to-peak input ripple voltage to the peak-to-peak output ripple voltage.

NOTE: This is the reciprocal of ripple sensitivity.

Ripple Sensitivity

The ratio of the peak-to-peak output ripple voltage, sometimes expressed as a percentage of output voltage, to the peak-to-peak input ripple voltage.

NOTE: This is the reciprocal of ripple rejection.

Output Regulation

The change in output voltage, often expressed as a percentage of output voltage, for a change in load current from one level to another level.

Output Resistance

The output resistance under small-signal conditions.

Temperature Coefficient of Output Voltage (α_{VO})

The ratio of the change in output voltage, usually expressed as a percentage of output voltage, to the change in temperature. This is the average value for the total temperature change.

$$\alpha_{VO} = \pm \left[\frac{V_O \text{ at } T_2 - V_O \text{ at } T_1}{V_O \text{ at } 25^\circ\text{C}} \right] \frac{100\%}{T_2 - T_1}$$

Output Voltage Change with Temperature

The percentage change in the output voltage for a change in temperature. This is the net change over the total temperature range.

Output Voltage Long-Term Drift

The change in output voltage over a long period of time.

Output Noise Voltage

The rms output noise voltage, sometimes expressed as a percentage of the dc output voltage, with constant load and no input ripple.

Current-Limit Sense Voltage

The current-sense voltage at which current limiting occurs.

GLOSSARY

VOLTAGE-REGULATOR TERMS AND DEFINITIONS

Current-Sense Voltage

The voltage that is a function of the load current and is normally used for control of the current-limiting circuitry.

Dropout Voltage

The low input-to-output differential voltage at which the circuit ceases to regulate against further reductions in input voltage.

Feedback Sense Voltage

The voltage that is a function of the output voltage and is used for feedback control of the regulator.

Reference Voltage

The voltage that is compared with the feedback sense voltage to control the regulator.

Bias Current

The difference between input and output currents.

NOTE: This is sometimes referred to as quiescent current.

Standby Current

The input current drawn by the regulator with no output load and no reference voltage load.

Short-Circuit Output Current

The output current of the regulator with the output shorted to ground.

Peak Output Current

The maximum output current that can be obtained from the regulator due to limiting circuitry within the regulator.

SHUNT REGULATORS

NOTE: These terms and symbols are based on JEDEC and IEC standards for voltage regulator diodes.

Shunt Regulator

A device having a voltage-current characteristic similar to that of a voltage-regulator diode; normally biased to operate in a region of low differential resistance (corresponding to the breakdown region of a regulator diode) to develop across its terminals an essentially constant voltage throughout a specified current range.

Anode

The electrode to which the regulator current flows within the regulator when it is biased for regulation.

Cathode

The electrode from which the regulator current flows within the regulator when it is biased for regulation.

GLOSSARY

VOLTAGE-REGULATOR TERMS AND DEFINITIONS

Reference Input Voltage (V_{ref}) (of an adjustable shunt regulator)

The voltage at the reference input terminal with respect to the anode terminal.

Temperature Coefficient of Reference Voltage (αV_{ref})

The ratio of the change in reference voltage to the change in temperature. This is the average value for the total temperature change.

To obtain a value in ppm/°C:

$$\alpha V_{ref} = \left[\frac{V_{ref} \text{ at } T_2 - V_{ref} \text{ at } T_1}{V_{ref} \text{ at } 25^\circ\text{C}} \right] \frac{10^6}{T_2 - T_1}$$

Regulator Voltage (V_Z)

The dc voltage across the regulator.

Regulator Current (I_Z)

The dc current through the regulator when it is biased for regulation.

Regulator Current near Lower Knee of Regulation Range (I_{ZK})

The regulator current near the lower limit of the region within which regulation occurs; this corresponds to the breakdown knee of a regulator diode.

Regulator Current at Maximum Limit of Regulation Range (I_{ZM})

The regulator current above which the differential resistance of the regulator significantly increases.

Differential Regulator Resistance (r_Z)

The quotient of a change in voltage across the regulator and the corresponding change in current through the regulator when it is biased for regulation.

Noise Voltage (V_{nz})

The rms noise voltage with the regulator biased for regulation and with no input ripple.

REGULATOR SELECTION GUIDE

VARIABLE-VOLTAGE SERIES REGULATORS

SERIES	OUTPUT VOLTAGE	INPUT VOLTAGE	INPUT-TO-OUTPUT VOLTAGE	OUTPUT CURRENT	PACKAGES‡	PAGE
	V	V	V	A		
LM105	4.5 to 40	8.5 to 50	3 to 30	0.012	JG,L,P	91
uA723	2 to 37	9.5 to 40	3 to 38	0.150	J,L,N,U	143
LM117	Floating	Floating	3 to 40	0.5 and 1.5 †	KC,KD,LA	99
LM376	5 to 37	9 to 40	3 to 30	0.025	JG,L,P	91
LM104	-0.015 to -40	-8 to -50	-0.5 to -50	0.020	J,L,N	87

‡ Not every device type is available in each package shown for the series. See individual data sheets for specific information.

† The 1.5-A rating applies only to the LM217 and the LM317 in the KC package.

ADJUSTABLE SHUNT REGULATOR

SERIES	OUTPUT VOLTAGE	TEMPERATURE COEFFICIENT OF OUTPUT VOLTAGE	MAXIMUM CURRENT	PACKAGES	PAGE
	V	ppm/°C	mA		
TL430	2.7 to 30	200 MAX	100	JG,LP	125
TL431*	2.7 to 30	100 MAX	100	JG,LP	129

*Future product to be announced.

SWITCHING-REGULATOR CONTROL CIRCUITS WITH UNCOMMITTED OUTPUTS

SERIES	DESCRIPTION	OUTPUT MODE	MAXIMUM OUTPUT CURRENT	PACKAGES‡	PAGE
			mA		
TL497A	Fixed "on" time, variable frequency	Single-ended	500	J,N	137
SG1524	Variable duty cycle, fixed frequency	Push-pull	100	J,N	113
TL494*	Variable duty cycle, fixed frequency	Push-pull	200	J,N	135

‡ Not every device type is available in each package shown for the series. See individual data sheets for specific information.

REGULATOR SELECTION GUIDE

FIXED-VOLTAGE SERIES REGULATORS

SERIES	OUTPUT VOLTAGE – V														
	2.6	5	5.2	6	6.2	8	8.5	9	10	12	15	18	20	22	24
LM109		+													
LM340		+		+		+			+	+	+	+			+
TL7805AC		+													
uA7800		+		+		+	+		+	+	+	+		+	+
uA78L00	+	+			+			+		+	+				
uA78M00		+		+		+				+	+		+	+	+
uA7900		–	–	–		–				–	–	–			–
uA79M00		–		–		–				–	–		–		–

SERIES	OUTPUT VOLTAGE TOLERANCE	INPUT-TO-OUTPUT MINIMUM VOLTAGE	MAXIMUM OUTPUT CURRENT	INPUT VOLTAGE RANGE [†]	PACKAGES [‡]	PAGE
	±%	V	A	V		
LM109	8	2	0.5	7 to 25	LA	95
LM340	5 and 10	2	1 and 1.5 [§]	7 to 38	KC	105
TL7805AC	3	2	1.5	7 to 25	KC	141
uA7800	5	2 to 3	1.5	7 to 38	KC	149
uA78L00	5 and 10	2 to 2.5	0.1	4.75 to 30	JG,LP	157
uA78M00	5	2 to 3	0.5	7 to 38	KC,KD,LA	163
uA7900	5	–2 to –3	–1.5	–7 to –38	KC	173
uA79M00	5	–2 to –3	–0.5	–7 to –38	KC,KD,LA	179

[†]Individual devices in each series offer a selection of input voltage limits within the range shown.

[‡]Not every device type is available in each package shown for the series. See individual data sheets for specific information.

[§]Some of these devices with higher output voltages (i.e., >18 V) must be limited to 1 A maximum.

TIMER/REGULATOR/COMPARATOR BUILDING BLOCKS

TL432. page 133

REGULATOR ALPHANUMERIC INDEX

	PAGE		PAGE
LM104	87	uA78L05	157
LM105	91	uA78L05A	157
LM109	95	uA78L06	157
LM117	99	uA78L06A	157
LM204	87	uA78L08	157
LM205	91	uA78L08A	157
LM209	95	uA78L09	157
LM217	99	uA78L09A	157
LM304	87	uA78L10	157
LM305	91	uA78L10A	157
LM305A	91	uA78L12	157
LM309	95	uA78L12A	157
LM317	99	uA78L15	157
LM340	105	uA78L15A	157
LM376	91	uA78M05	163
SG1524	113	uA78M06	163
SG2524	113	uA78M08	163
SG3524	113	uA78M12	163
TL430	125	uA78M15	163
TL431	129	uA78M20	163
TL432	133	uA78M22	163
TL494	135	uA78M24	163
TL497A	137	uA7905	173
TL7805A	141	uA7906	173
uA723	143	uA7908	173
uA7805	149	uA7912	173
uA7806	149	uA7915	173
uA7808	149	uA7918	173
uA7810	149	uA7924	173
uA7812	149	uA7952	173
uA7815	149	uA79M05	179
uA7818	149	uA79M06	179
uA7822	149	uA79M08	179
uA7824	149	uA79M12	179
uA7885	149	uA79M15	179
uA78L02	157	uA79M20	179
uA78L02A	157	uA79M24	179

INDEX TO APPLICATIONS CIRCUITS

	DATA SHEET	PAGE	FIGURE
BASIC REGULATOR CIRCUITS			
Positive-Voltage Regulators			
Adjustable Regulator	LM105	93	1
Shunt Regulator	LM105	94	6
Adjustable Series Regulator	LM117	102	1
Series Regulator with Improved Ripple Rejection	LM117	102	3
Adjustable Shunt Regulator	TL430†	128	8
Adjustable Series Regulator	TL430†	128	9
Shunt Regulator	TL432	133	1
Series Regulator	TL432	133	2
Series Regulator with 2-V to 7-V Output	μ A723	147	1
Series Regulator with 7-V to 37-V Output	μ A723	147	2
Shunt Regulator	μ A723	148	12
Negative-Voltage Regulators			
Adjustable Regulator	LM104	89	1
Series Regulator	μ A723	147	3
HIGH-CURRENT CIRCUITS ($I_{OUT} \geq 1$ A)			
Positive-Voltage Regulators			
1-A, 28-V Regulator	LM105	94	5
1.5-A Adjustable Regulator	LM117	102	1
1.5-A Adjustable Regulator with Improved Ripple Rejection	LM117	102	3
1.5-A Adjustable Series Regulator	LM117	102	5
1.5-A, 1.2-V to 20-V Series Regulator	LM117	102	6
4-A Adjustable Series Regulator	LM117	103	13
Adjustable Series Regulator	LM117	103	14
Current Boost Circuit for Fixed Regulators	LM340	111	7
Adjustable Series Regulator	TL430†	128	11
Adjustable Series Regulator Driving N-P-N Pass Transistor	μ A723	147	4
Adjustable Series Regulator Driving P-N-P Pass Transistor	μ A723	147	5
Negative-Voltage Regulators			
2-A, -10-V Regulator	LM104	89	2
CONSTANT-CURRENT AND CURRENT-LIMITING CIRCUITS			
Series Voltage Regulator with Current Limiting	LM105	93	1
Series Voltage Regulator with Foldback Current Limiting	LM105	93	2
5-V, 10-A Series Voltage Regulator with Foldback Current Limiting	LM105	94	3
1-A Constant-Current Source	LM105	94	4
Precision Constant-Current Source	LM117	102	4
50-mA Constant-Current Battery Charger	LM117	103	9
Current-Limited 6-V Battery Charger	LM117	103	12
Adjustable Precision Constant-Current Source	TL430†	128	10
Foldback Current Limiting Circuit	μ A723	147	6
Series Voltage Regulator with Current Limit and Remote Shutdown	μ A723	148	11

†The identical circuits for TL431 appear on page 132.

INDEX TO APPLICATIONS CIRCUITS (Continued)

	DATA SHEET	PAGE	FIGURE
FLOATING REGULATOR CIRCUITS			
Split-Rail Series Regulator	LM104	89	4
Basic Series Regulator	LM117	102	6
Adjustable Series Regulator, 0-V to 30-V	LM117	102	2
Adjustable Regulator with Improved Ripple Rejection	LM117	102	3
Precision Constant-Current Source	LM117	102	4
High-Current Adjustable Regulator	LM117	103	14
Current-Limiting Circuit	TL430†	128	10
Positive-Voltage Regulator	uA723	148	7
Negative-Voltage Regulator	uA723	148	8
SWITCHING REGULATOR CIRCUITS			
-5-V, 3-A Voltage Regulator	LM104	89	3
5-V Regulator	LM105	94	7
Capacitor-Diode-Output PWM Circuit	SG1524	122	12
Flyback Converter PWM Circuit	SG1524	122	13
Single-Ended LC Circuit	SG1524	123	14
Push-Pull Transformer-Coupled PWM Circuit	SG1524	123	15
Step-Up Regulator	TL497A	139	1
Step-Down Regulator	TL497A	139	2
Inverting Regulator	TL497A	140	3
Extended-Input-Voltage-Range Switching Regulator	TL497A	140	4
Positive-Voltage Switching Regulator	uA723	148	9
Negative-Voltage Switching Regulator	uA723	148	10
SPECIAL FUNCTIONS			
Split-Rail Series Regulator	LM104	89	4
Tracking Preregulator	LM117	102	5
Common Adjustment of Multiple Regulators	LM117	102	7
Battery Charger	LM117	103	8
Slow-Turn-On 15-V Regulators	LM117	103	10
AC Limiter	LM117	103	11
Timing Circuit	TL432	133	3
Over-Voltage Protection Circuit	TL432	133	4
Output Control for a Three-Terminal Regulator	TL430†	128	11
Over-Voltage/Under-Voltage Protection Circuit	TL430†	128	14

†The identical circuits for the TL431 appear on page 132.

LINEAR INTEGRATED CIRCUITS

TYPES LM104, LM204, LM304 NEGATIVE-VOLTAGE REGULATORS

BULLETIN NO. DL-S 12052, SEPTEMBER 1973—REVISED JUNE 1976

FORMERLY SN52104, SN72104

- Typical Load Regulation . . . 1 mV
- Typical Input Regulation . . . 0.06%
- Designed to be Interchangeable with National Semiconductor LM104, LM204, and LM304 Respectively

description

The LM104, LM204, and LM304 are monolithic integrated circuit voltage regulators that can be programmed with a single external resistor to provide any voltage between -40 volts and approximately 0 volts while operating from a single unregulated negative supply. When used with a separate floating bias supply, these devices can provide regulation with the output voltage limited only by the breakdown characteristics of the external pass transistors.

Although designed primarily for application as linear series regulators at output currents up to 25 milliamperes, the LM104, LM204, and LM304 can be used as current regulators, switching regulators, or control elements with the output current limited by the capability of the external pass transistors. The improvement factor for load regulation is approximately equal to the composite current gain of the added transistors. The devices can be used in either constant-current or fold-back current-limiting applications.

The LM104 is characterized for operation over the full military temperature range of -55°C to 125°C; the LM204 is characterized for operation from -25°C to 85°C; and the LM304 is characterized for operation from 0°C to 70°C.

schematic

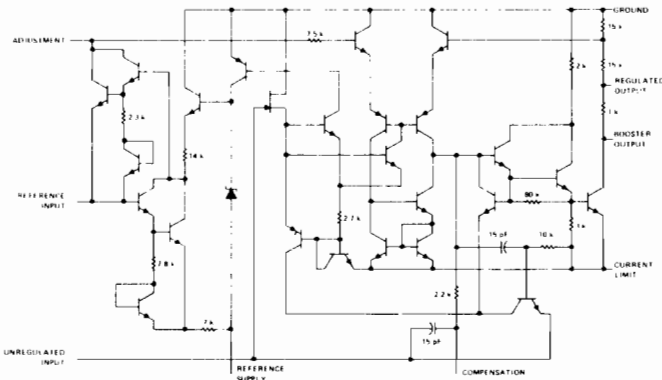

Component values shown are nominal.
Resistor values are in ohms.

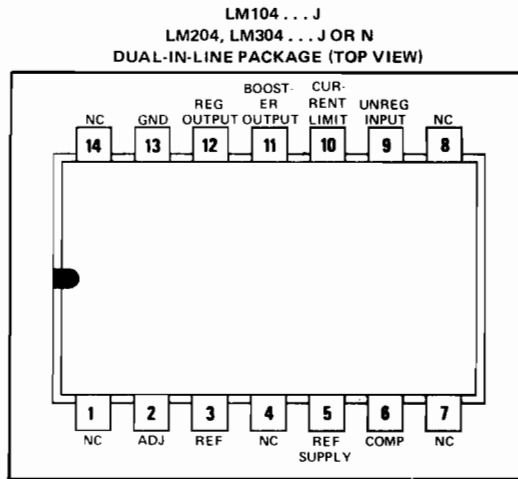
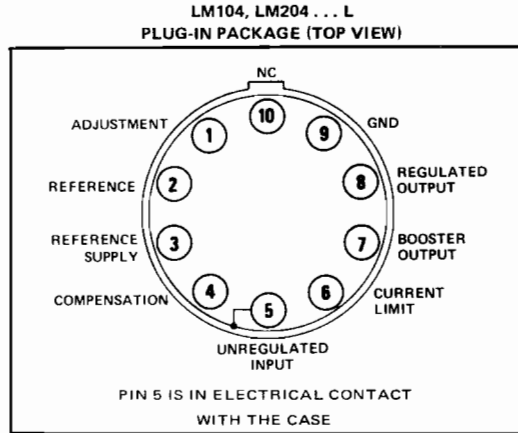

NC: No internal connection

TYPES LM104, LM204, LM304

NEGATIVE-VOLTAGE REGULATORS

absolute maximum ratings over operating free-air temperature range (unless otherwise noted)

		LM104	LM204	LM304	UNIT
Input voltage (see Note 1)		-50	-50	-40	V
Input-to-output voltage differential		-50	-50	-40	V
Continuous total dissipation at (or below) 25°C free-air temperature (see Note 2)	J or N package	1000	1000	1000	mW
	L package	800	800	800	
Operating free-air temperature range		-55 to 125	-25 to 85	0 to 70	°C
Storage temperature range		-65 to 150	-65 to 150	-65 to 150	°C
Lead temperature 1/16 inch from case for 60 seconds: J or L package		300	300	300	°C
Lead temperature 1/16 inch from case for 10 seconds: N package			260	260	°C

NOTES: 1. Voltage values, except input-to-output voltage differential, are with respect to network ground terminal.

2. For operation above 25°C free-air temperature, refer to Dissipation Derating Table, Figures I, II, and III, page 90. This rating for the L package requires a heat sink that provides a thermal resistance from case to free-air, $R_{\theta CA}$, of not more than 105°C/W.

recommended operating conditions

		LM104		LM204		LM304		UNIT
		MIN	MAX	MIN	MAX	MIN	MAX	
Input voltage, V_I		-8	-50	-8	-50	-8	-40	V
Output voltage, V_O		-0.015	-40	-0.015	-40	-0.035	-30	V
Input-to-output voltage differential, $V_I - V_O$	$I_O = 20$ mA	-2	-50	-2	-50	-2	-40	V
	$I_O \leq 5$ mA	-0.5	-50	-0.5	-50	-0.5	-40	
Output current, I_O		20		20		20		mA
Operating free-air temperature, T_A		-55	125	-25	85	0	70	°C

electrical characteristics over recommended ranges of input and output voltage and operating free-air temperature (unless otherwise noted)

PARAMETER	TEST CONDITIONS†	LM104, LM204			LM304			UNIT
		MIN	TYP	MAX	MIN	TYP	MAX	
Input regulation	$V_O = -5$ V to MAX, $\Delta V_I = 0.1 V_I$, See Notes 3 and 4	0.06	0.1		0.06	0.1		%
Ripple sensitivity	$C_1 = 10$ μ F, $f = 120$ Hz	$V_I = -15$ V to MAX	0.2	0.5		0.2	0.5	mV/V
		$V_I = -7$ V to -15 V	0.5	1		0.5	1	
Output regulation	$I_O = 0$ to 20 mA, $R_{SC} = 15$ Ω , See Note 3		1	5		1	5	mV
Output voltage scale factor	$R_1 = 2.4$ k Ω , See Figure 2	1.8	2	2.2	1.8	2	2.2	V/k Ω
Output voltage change with temperature	$T_A = \text{MIN}$ to $T_A = 25^\circ\text{C}$			1			1	%
	$T_A = 25^\circ\text{C}$ to $T_A = \text{MAX}$			1			1	
Output noise voltage	$V_O = -5$ V to MAX, $C_1 = 0$		0.007			0.007		%
	$f = 10$ Hz to 10 kHz		15			15		
Bias current	$I_O = 5$ mA	$V_O = 0$	1.7	2.5		1.7	2.5	mA
		$V_O = -30$ V				3.6	5	
		$V_O = -40$ V	3.6	5				

† For conditions shown as MIN or MAX, use the appropriate value specified under recommended operating conditions.

NOTES: 3. Input regulation and output regulation are measured using pulse techniques ($t_w \leq 10$ μ s, duty cycle $\leq 5\%$) to limit changes in average internal dissipation. Output voltages due to large changes in internal dissipation must be taken into account separately.

4. At zero output voltage, the output variation can be determined using the ripple sensitivity. At low voltages (i.e., 0 to -5 V), the output variation determined from the ripple sensitivity must be added to the variation determined from the input regulation to determine the overall line regulation.

TYPES LM104, LM204, LM304 NEGATIVE-VOLTAGE REGULATORS

TYPICAL APPLICATION DATA

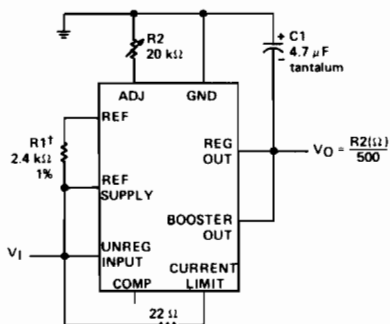

FIGURE 1—BASIC REGULATOR CIRCUIT

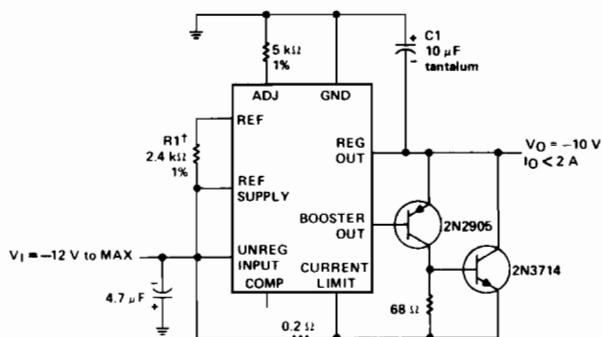
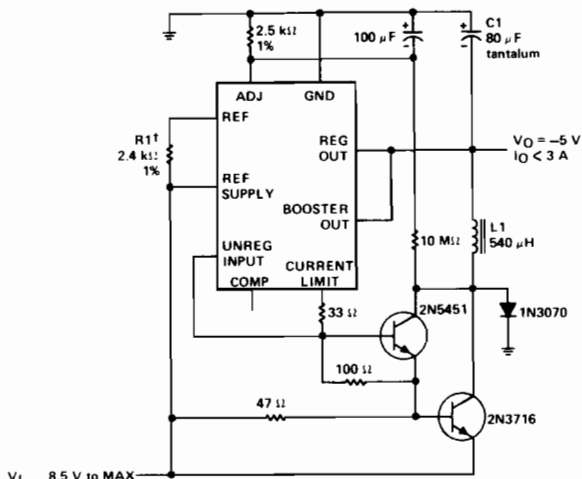

FIGURE 2—HIGH-CURRENT REGULATOR



L1: 60 turns #20 on Arnold Engineering A930157-2 molybdenum permalloy core, or equivalent

FIGURE 3—SWITCHING REGULATOR

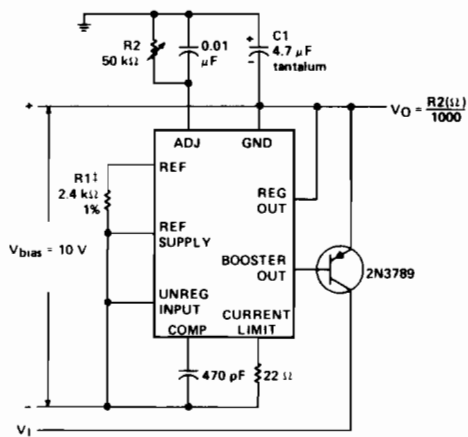

FIGURE 4—OPERATING WITH SEPARATE BIAS SUPPLY

[†]Trim R1 for exact scale factor.

VOLTAGE REGULATORS

THERMAL INFORMATION

These curves are for use with the continuous dissipation ratings specified on the individual data sheets. Those ratings apply up to the temperature at which the rated level intersects the appropriate derating curve or the maximum operating free-air temperature.

J AND JG PACKAGE FREE-AIR TEMPERATURE DISSIPATION DERATING CURVES

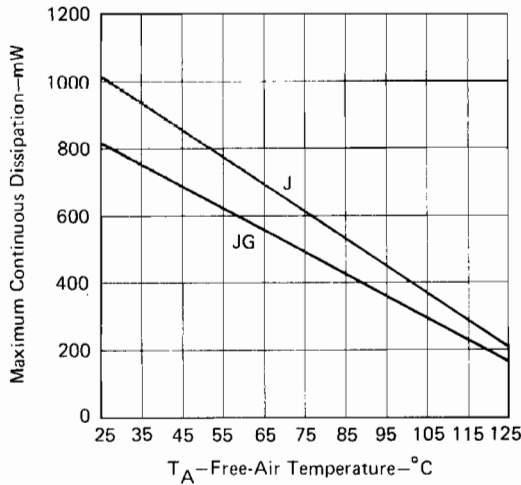

FIGURE I

L PACKAGE FREE-AIR TEMPERATURE DISSIPATION DERATING CURVES

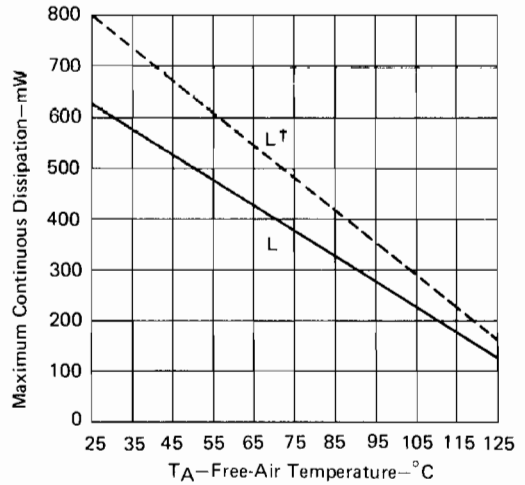

FIGURE II

N PACKAGE FREE-AIR TEMPERATURE DISSIPATION DERATING CURVES

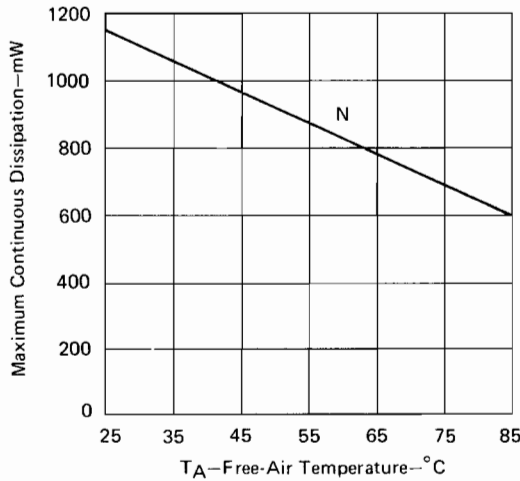

FIGURE III

P PACKAGE FREE-AIR TEMPERATURE DISSIPATION DERATING CURVES

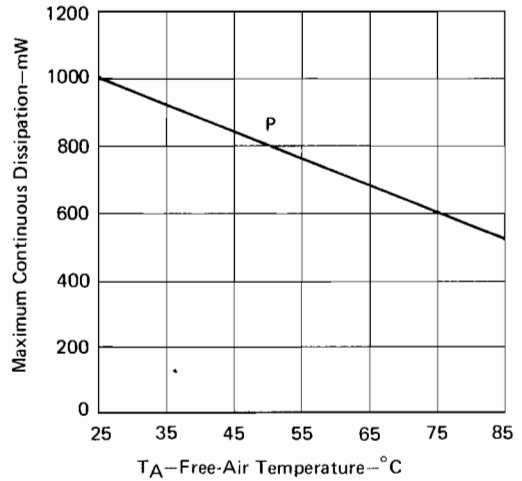

FIGURE IV

† This rating for the L package requires a heat sink that provides a thermal resistance from case to free-air, $R_{\theta CA}$, of not more than 105°C/W .

LINEAR INTEGRATED CIRCUITS

TYPES LM105, LM205, LM305, LM305A, LM376 POSITIVE-VOLTAGE REGULATORS

BULLETIN NO. DL-S 12057, SEPTEMBER 1973—REVISED JUNE 1976

FORMERLY SN52105, SN72305,
SN72305A, SN72376

- Low Standby Current . . . 0.8 mA Typ
- Adjustable Output Voltage
- Load Regulation . . . 0.1% Max (LM105, LM205, LM305)
- Input Regulation . . . 0.06%/V Max
- Designed to be Interchangeable with National LM105, LM205, LM305, LM305A, and LM376 Respectively

description

The LM105, LM205, LM305, LM305A and LM376 are monolithic positive-voltage regulators designed for a wide range of applications from digital power supplies to precision regulators for analog systems. These devices will not oscillate under conditions of varying resistive and reactive loads and will start reliably with any load within the rating of the circuits.

The LM105 is characterized for operation over the full military temperature range of -55°C to 125°C ; the LM205 is characterized for operation from -25°C to 85°C , and the LM305, LM305A, and LM376 are characterized for operation from 0°C to 70°C .

LM105 . . . JG
LM205, LM305, LM305A, LM376 . . . JG OR P
DUAL-IN-LINE PACKAGE (TOP VIEW)

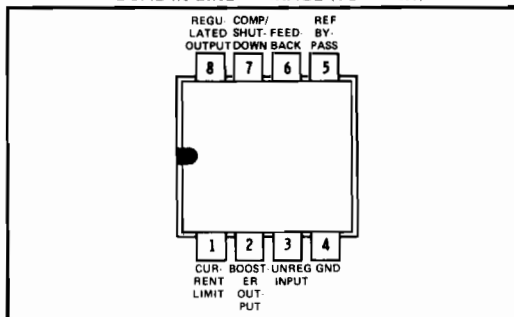

LM105, LM205, LM305, LM305A, LM376 . . . L
PLUG-IN PACKAGE (TOP VIEW)

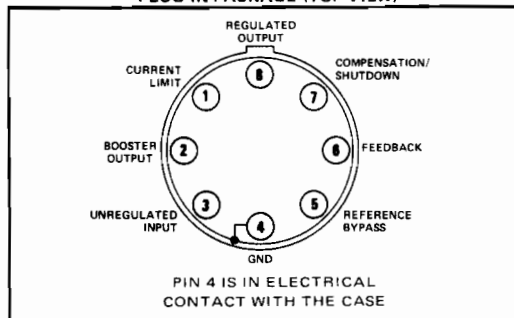

schematic

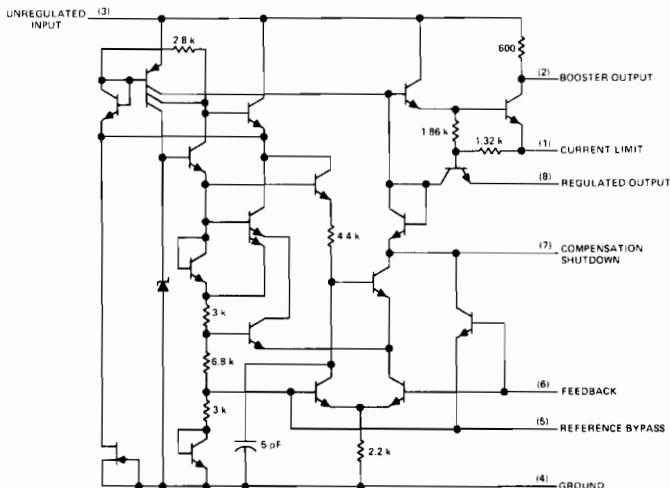

Component values shown are nominal.
Resistor values are in ohms.

Copyright © 1976 by Texas Instruments Incorporated

TEXAS INSTRUMENTS
INCORPORATED
POST OFFICE BOX 5012 • DALLAS, TEXAS 75222

TYPES LM105, LM205, LM305, LM305A, LM376

POSITIVE-VOLTAGE REGULATORS

absolute maximum ratings over operating free-air temperature range (unless otherwise noted)

	LM105	LM205	LM305A	LM305 LM376	UNIT
Input voltage (see Note 1)	50	50	50	40	V
Input-to-output voltage differential	40	40	40	40	V
Continuous total dissipation at (or below) 25°C free-air temperature (see Note 2)	800	800	800	800	mW
Operating free-air temperature range	-55 to 125	-25 to 85	0 to 70	0 to 70	°C
Storage temperature range	-65 to 150	-65 to 150	-65 to 150	-65 to 150	°C
Lead temperature 1/16 inch from case for 60 seconds: JG or L package	300	300	300	300	°C
Lead temperature 1/16 inch from case for 10 seconds: P package		260	260	260	°C

NOTES: 1. Voltage values, except input-to-output voltage differential, are with respect to network ground terminal.

2. For operation above 25°C free-air temperature, refer to Dissipation Derating Curves, Figures I, II, and IV, page 90. This rating for the L package requires a heat sink that provides a thermal resistance from case to free-air, $R_{\theta CA}$, of not more than 105°C/W.

recommended operating conditions

	LM105		LM205		LM305A		LM305		LM376		UNIT
	MIN	MAX	MIN	MAX	MIN	MAX	MIN	MAX	MIN	MAX	
Input voltage, V_I	8.5	50	8.5	50	8.5	50	8.5	40	9	40	V
Output voltage, V_O	4.5	40	4.5	40	4.5	40	4.5	30	5	37	V
Input-to-output voltage differential, $V_I - V_O$	3	30	3	30	3	30	3	30	3	30	V
Output current, I_O	0	12	0	12	0	45	0	12	0	25	mA
Operating free-air temperature, T_A	-55	125	-25	85	0	70	0	70	0	70	°C

LM105, LM205, LM305 electrical characteristics[†] at 25°C free-air temperature (unless otherwise noted)

PARAMETER	TEST CONDITIONS [‡]		LM105, LM205			LM305			UNIT	
			MIN	TYP	MAX	MIN	TYP	MAX		
Input regulation	$V_I - V_O \leq 5$ V		See Note 3			0.025	0.06	0.025	0.06	% / V
	$V_I - V_O > 5$ V					0.015	0.03	0.015	0.03	
Ripple sensitivity	$C_{ref} = 10 \mu F$, $f = 120$ Hz		0.003	0.01	0.003	0.01	0.003	0.01	% / V	
Output regulation (see Note 4)	$I_O = 0$ to $I_O = 12$ mA, See Note 3		$R_{SC} = 10 \Omega$, $T_A = 25^\circ C$			0.02	0.05	0.02	0.05	%
			$R_{SC} = 10 \Omega$, $T_A = \text{MIN}$			0.03	0.1	0.03	0.1	
			$R_{SC} = 10 \Omega$, $T_A = \text{MAX}$			0.03	0.1			
			$R_{SC} = 15 \Omega$, $T_A = \text{MAX}$					0.03	0.1	
Output voltage change with temperature	$T_A = \text{MIN}$ to $T_A = 25^\circ C$					1		1	%	
	$T_A = 25^\circ C$ to $T_A = \text{MAX}$					1		1		
Output noise voltage	$f = 10$ Hz to 10 kHz		$C_{ref} = 0$			0.005		0.005	%	
			$C_{ref} > 0.1 \mu F$			0.002		0.002		
Feedback sense voltage			1.63	1.7	1.81	1.63	1.7	1.81	V	
Current-limit sense voltage	$R_{SC} = 10 \Omega$, $V_O = 0$, See Note 5		225	300	375	225	300	375	mV	
Standby current	$V_I = 50$ V					0.8	2		mA	
	$V_I = 40$ V							0.8		2

[†] These specifications apply for input and output voltages within the ranges specified under recommended operating conditions and for a divider impedance of 2 k Ω presented to the feedback terminal, unless otherwise noted.

[‡] For conditions shown as MIN or MAX, use the appropriate value specified under recommended operating conditions.

NOTES: 3. Input regulation and output regulation are measured using pulse techniques ($t_w \leq 10 \mu s$, duty cycle $\leq 5\%$) to limit changes in average internal dissipation. Output voltage changes due to large changes in internal dissipation must be taken into account separately.

4. Load regulation and output current capacity can be improved by the addition of external transistors. The improvement factor will be approximately equal to the composite current gain of the added transistors.

5. Current-limit sense voltage is measured without an external pass transistor.

TYPES LM105, LM205, LM305, LM305A, LM376

POSITIVE-VOLTAGE REGULATORS

LM305A, LM376 electrical characteristics[†] at 25°C free-air temperature (unless otherwise noted)

PARAMETER	TEST CONDITIONS [‡]		LM305A		LM376		UNIT	
			MIN	TYP	MAX	MIN		TYP
Input regulation	$V_I - V_O \leq 5 \text{ V}$	See Note 3	0.025		0.06		% / V	
	$V_I - V_O > 5 \text{ V}$		0.015		0.03			
	$T_A = 0^\circ\text{C to } 70^\circ\text{C}$				0.1			
Ripple sensitivity	$C_{\text{ref}} = 10 \mu\text{F}$, $f = 120 \text{ Hz}$		0.003				% / V	
Output regulation (see Note 4)	$I_O = 0 \text{ to } I_O = \text{MAX}$, See Note 3	$R_{\text{SC}} = 0 \Omega$, $T_A = 25^\circ\text{C}$	0.02	0.2	0.2		%	
		$R_{\text{SC}} = 0 \Omega$, $T_A = 0^\circ\text{C}$	0.03		0.4			
		$R_{\text{SC}} = 0 \Omega$, $T_A = 70^\circ\text{C}$	0.03		0.4			
Output voltage change with temperature	$T_A = 0^\circ\text{C to } T_A = 25^\circ\text{C}$		1		1		%	
	$T_A = 25^\circ\text{C to } T_A = 70^\circ\text{C}$		1		1			
Output noise voltage	$f = 10 \text{ Hz to } 10 \text{ kHz}$	$C_{\text{ref}} = 0$	0.005				%	
		$C_{\text{ref}} > 0.1 \mu\text{F}$	0.002					
Feedback sense voltage			1.55	1.7	1.85			
	$T_A = 0^\circ\text{C to } T_A = 70^\circ\text{C}$					1.6	1.7	1.8
Current limit sense voltage	$R_{\text{SC}} = 10 \Omega$, $V_O = 0 \text{ V}$	See Note 5	225	300	375	300		mV
Standby current	$V_I = 50 \text{ V}$		0.8		2		mA	
	$V_I = 30 \text{ V}$				2.5			

[†]These specifications apply for input and output voltages within the ranges specified under recommended operating conditions, and for a divider impedance of 2 kΩ presented to the feedback terminal, unless otherwise noted.

[‡]For conditions shown as MIN or MAX, use the appropriate value specified under recommended operating conditions.

NOTES: 3. Input regulation and output regulation are measured using pulse techniques ($t_w \leq 10 \mu\text{s}$, duty cycle $\leq 5\%$) to limit changes in average internal dissipation. Output voltage changes due to large changes in internal dissipation must be taken into account separately.

4. Load regulation and output current capacity can be improved by the addition of external transistors. The improvement factor will be approximately equal to the composite current gain of the added transistors.
5. Current-limit sense voltage is measured without an external pass transistor.

TYPICAL APPLICATION DATA

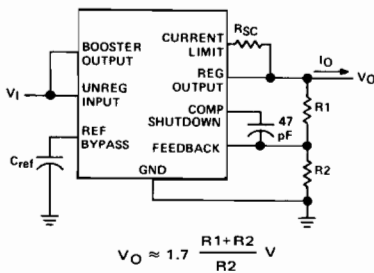

FIGURE 1—BASIC REGULATOR WITH CURRENT LIMITING

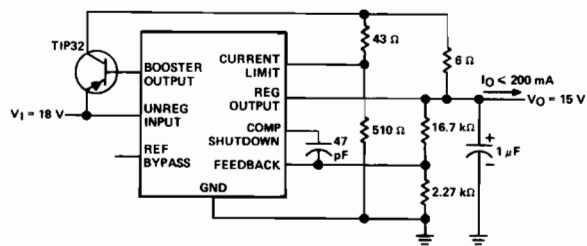

FIGURE 2—LINEAR REGULATOR WITH FOLDBACK CURRENT LIMITING

TYPES LM105, LM205, LM305, LM305A, LM376 POSITIVE-VOLTAGE REGULATORS

TYPICAL APPLICATION DATA

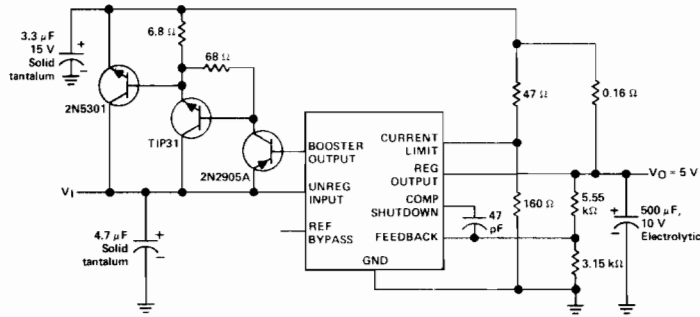

FIGURE 3—10-A REGULATOR WITH FOLDBACK CURRENT LIMITING

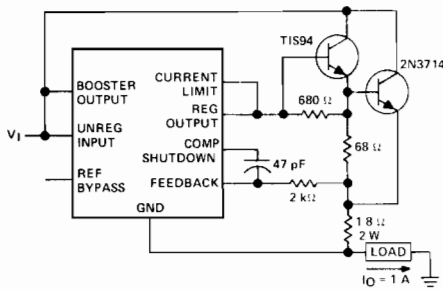
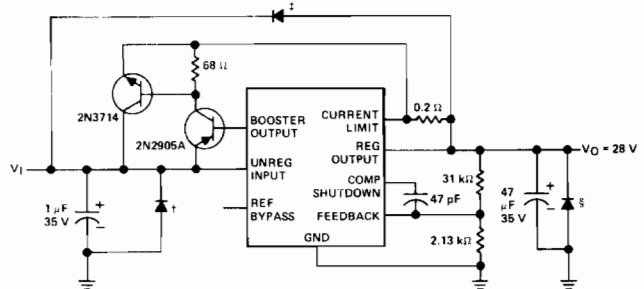

FIGURE 4—CURRENT REGULATOR



- † Protects against input voltage reversal.
- ‡ Protects against shorted input or inductive loads on unregulated supply.
- § Protects against output voltage reversal.

FIGURE 5—1-A REGULATOR WITH PROTECTIVE DIODES

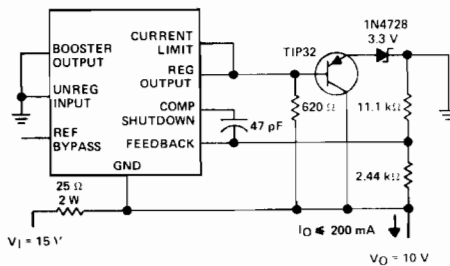

FIGURE 6—SHUNT REGULATOR

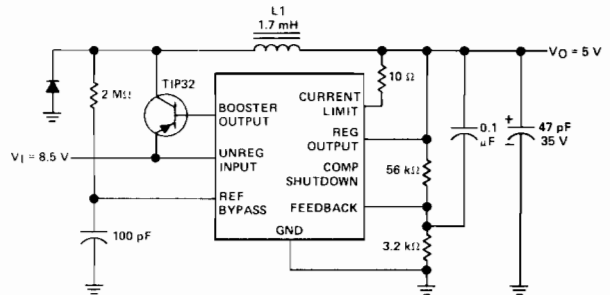
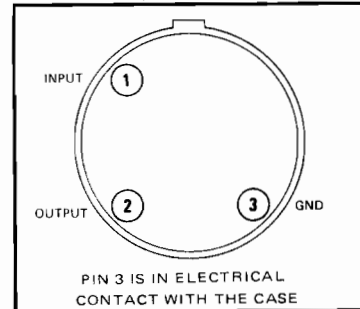

FIGURE 7—SWITCHING REGULATOR

FORMERLY SN52109, SN72309

- No External Components Required for Most Applications
- Output Current . . . 500 mA Max
- Satisfies 5-V Supply Requirements of TTL and DTL
- Virtually Blow-Out Proof Due to Internal Current Limiting, Thermal Shutdown, and Safe-Operating-Area Compensation
- Designed to be Interchangeable with National LM109, LM209, and LM309 Respectively

LA PLUG-IN PACKAGE
(TOP VIEW)



description

These monolithic 5-volt regulators are designed for use as local regulators to eliminate noise and distribution problems inherent with single-point regulation. They are specified under worst-case conditions to match the power supply requirements of TTL and DTL logic families. In other applications, these devices can be used with external components to obtain adjustable output voltages and currents or as the series-pass element in precision regulators.

schematic

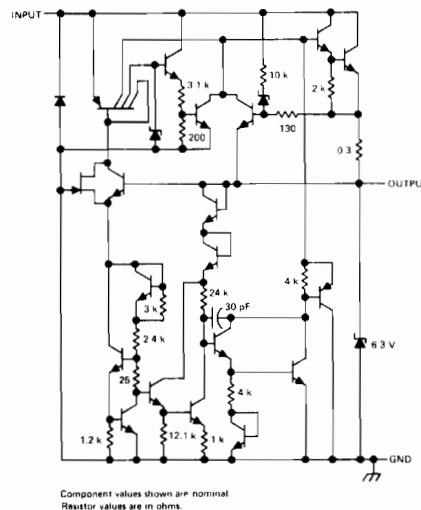

absolute maximum ratings over operating temperature range (unless otherwise noted)

	LM109, LM209	LM309	UNIT
Input voltage	35	35	V
Output current	500	500	mA
Continuous total dissipation at (or below) 25°C case temperature (see Note 1)	5	4	W
Continuous total dissipation at (or below) 25°C free-air temperature (see Note 2)	600	480	mW
Operating case or virtual junction temperature range	-55 to 150	0 to 125	°C
Storage temperature range	-65 to 150	-65 to 150	°C
Lead temperature 1/16 inch from case for 60 seconds	300	300	°C

NOTES: 1. Above 25°C case temperature, derate linearly at the rate of 40 mW/°C, or refer to Dissipation Derating Curve, Figure 1, next page.
2. Above 25°C free-air temperature, derate linearly at the rate of 4.8 mW/°C, or refer to Dissipation Derating Curve, Figure 2, next page.

TYPES LM109, LM209, LM309

5-VOLT REGULATORS

recommended operating conditions

	LM109		LM209		LM309		UNIT
	MIN	MAX	MIN	MAX	MIN	MAX	
Input voltage, V_I	7	25	7	25	7	25	V
Output current, I_O	0	500	0	500	0	500	mA
Operating virtual-junction temperature, T_J	-55	150	-25	150	0	125	°C

electrical characteristics at specified virtual junction temperature

PARAMETER	TEST CONDITIONS†			LM109, LM209			LM309			UNIT
				MIN	TYP	MAX	MIN	TYP	MAX	
Output voltage	$V_I = 10\text{ V}$, $I_O = 100\text{ mA}$	25°C	4.7	5.0	5.3	4.8	5.0	5.2	V	
	$V_I = 7\text{ V to } 25\text{ V}$, $I_O = 5\text{ mA to } 200\text{ mA}$	Full range	4.6		5.4	4.75		5.25		
Input regulation	$V_I = 7\text{ V to } 25\text{ V}$	25°C		4	50		4	50	mV	
Ripple rejection	$f = 120\text{ Hz}$	25°C		85			85		dB	
Output regulation	$I_O = 5\text{ mA to } I_O = 500\text{ mA}$, See Note 3	25°C		20	50		20	50	mV	
Output noise voltage	$f = 10\text{ Hz to } 100\text{ kHz}$	25°C		40			40		µV	
Standby current	$V_I = 7\text{ V to } 25\text{ V}$	Full range		5	10		5	10	mA	
	$V_I = 7\text{ V to } 25\text{ V}$, $I_O = 100\text{ mA}$	Full range			0.5			0.5		
Bias current change	$I_O = 5\text{ mA to } I_O = 200\text{ mA}$	Full range			0.8			0.8	mA	

† Full range for LM109 is -55°C to 150°C, for LM209 is -25°C to 150°C, and for LM309 is 0°C to 125°C. All characteristics, except output noise voltage and ripple rejection, are measured using pulse techniques. $t_w \leq 10\text{ ms}$, duty cycle $\leq 5\%$.

NOTE 3: Pulse techniques are used in testing to limit the average internal dissipation. Output voltage changes due to large changes in internal dissipation must be taken into account separately.

THERMAL INFORMATION

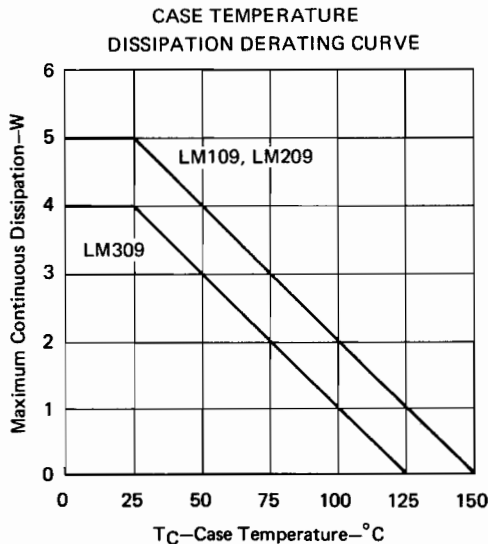

FIGURE 1

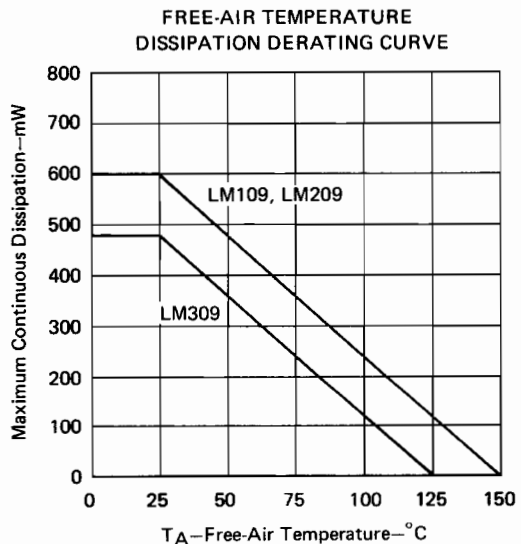

FIGURE 2

TYPES LM109, LM209, LM309 5-VOLT REGULATORS

TYPICAL CHARACTERISTICS†

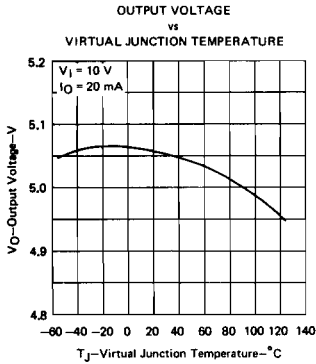

FIGURE 3

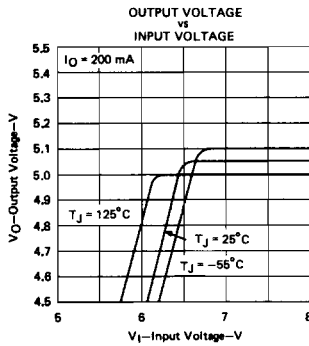

FIGURE 4

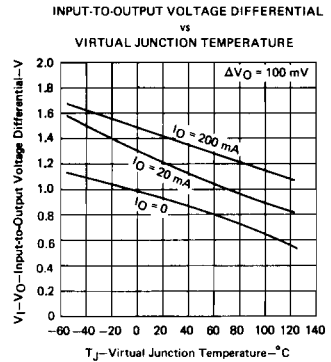

FIGURE 5

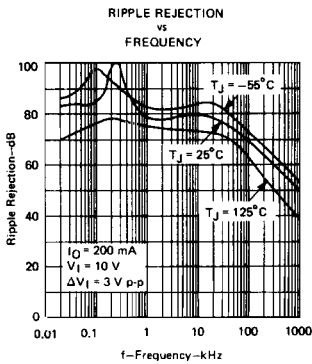

FIGURE 6

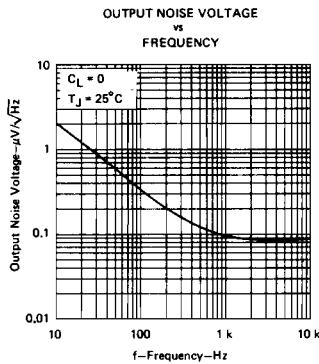

FIGURE 7

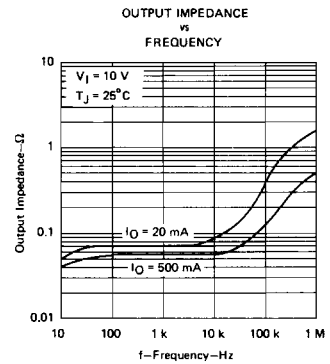

FIGURE 8

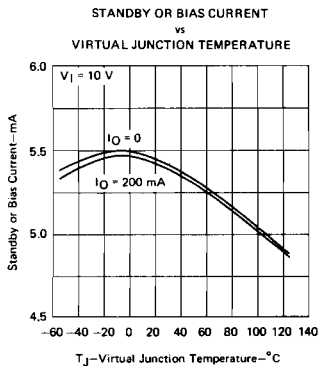

FIGURE 9

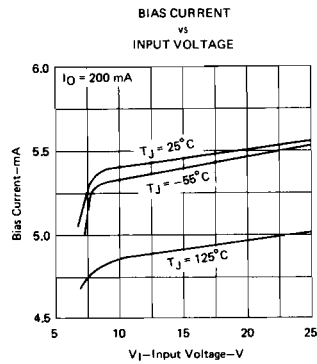

FIGURE 10

† Data for virtual junction temperatures outside the ranges specified in the recommended operating conditions for LM209 or LM309 is not applicable for those types.

TYPES LM109, LM209, LM309

5-VOLT REGULATORS

TYPICAL APPLICATION DATA

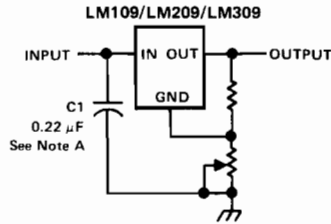

NOTE A: C1 is required if regulator is not located in close proximity to power supply filter.

FIGURE 11—ADJUSTABLE OUTPUT REGULATOR

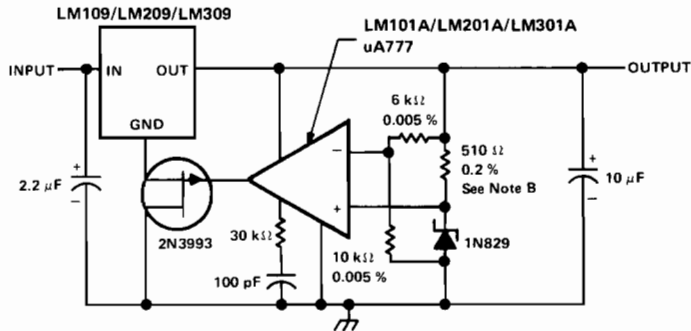

NOTES: A. All capacitors are solid tantalum.
B. This resistor determines zener current. Adjust to minimize thermal drift.

FIGURE 12—HIGH-STABILITY REGULATOR

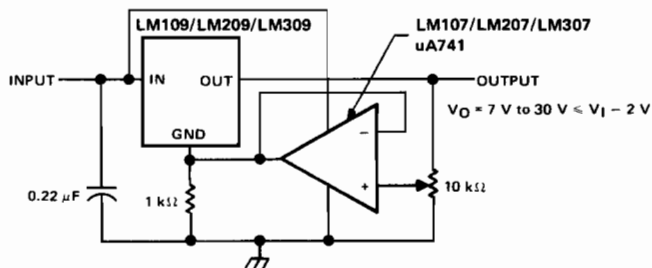

FIGURE 13—HIGH-STABILITY REGULATOR WITH ADJUSTABLE OUTPUT

LINEAR INTEGRATED CIRCUITS

TYPES LM117, LM217, LM317 3-TERMINAL ADJUSTABLE REGULATORS

BULLETIN NO. DL-S 12518, SEPTEMBER 1977

- Output Voltage Range Adjustable from 1.2 V to 37 V
- Guaranteed I_O Capability of 1.5 A for TO-220 package, 500 mA for LA and TO-202 packages
- Input Regulation Typically 0.01% Per Input-Volt Change
- Output Regulation Typically 0.1%
- Peak Output Current Constant Over Temperature Range of Regulator
- Popular 3-Lead Packages
- Ripple Rejection Typically 80 dB

terminal assignments

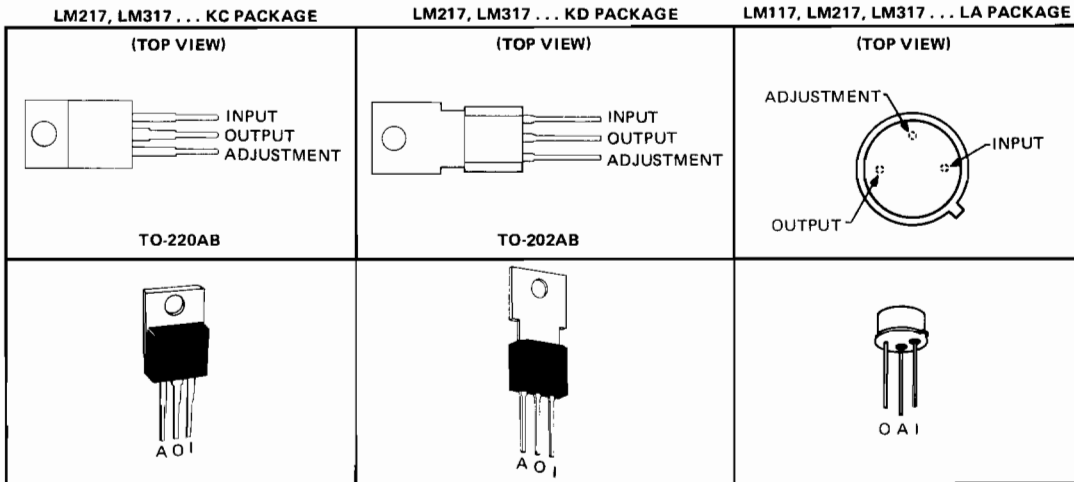

description

The LM117, LM217, and LM317 are adjustable 3-terminal positive-voltage regulators capable of supplying 1.5 amperes over a differential-voltage range of 1.2 volts to 37 volts. They are exceptionally easy to use and require only two external resistors to set the output voltage. Both input and output regulation are better than standard fixed regulators. The devices are packaged in standard transistor packages that are easily mounted and handled.

In addition to higher performance than fixed regulators, these regulators offer full overload protection available only in integrated circuits. Included on the chip are current limit, thermal overload protection, and safe-area protection. All overload protection circuitry remains fully functional even if the adjustment terminal is disconnected. Normally, no capacitors are needed unless the device is situated far from the input filter capacitors in which case an input bypass is needed. An optional output capacitor can be added to improve transient response. The adjustment terminal can be bypassed to achieve very high ripple rejection, which is difficult to achieve with standard 3-terminal regulators.

Besides replacing fixed regulators, these regulators are useful in a wide variety of other applications. Since the regulator is floating and sees only the input-to-output differential voltage, supplies of several hundred volts can be regulated as long as the maximum input-to-output differential is not exceeded. Its primary application is that of a programmable output regulator, but by connecting a fixed resistor between the adjustment terminal and the output terminal, this device can be used as a precision current regulator. Supplies with electronic shutdown can be achieved by clamping the adjustment terminal to ground, which programs the output to 1.2 volts where most loads draw little current.

The LM117 is characterized for operation over the full military temperature range of -55°C to 125°C . The LM217 and LM317 are characterized for operation from -25°C to 150°C and from 0°C to 125°C respectively.

Copyright © 1977 by Texas Instruments Incorporated

TEXAS INSTRUMENTS
INCORPORATED
POST OFFICE BOX 5012 • DALLAS, TEXAS 75222

TYPES LM117, LM217, LM317

3-TERMINAL ADJUSTABLE REGULATORS

schematic

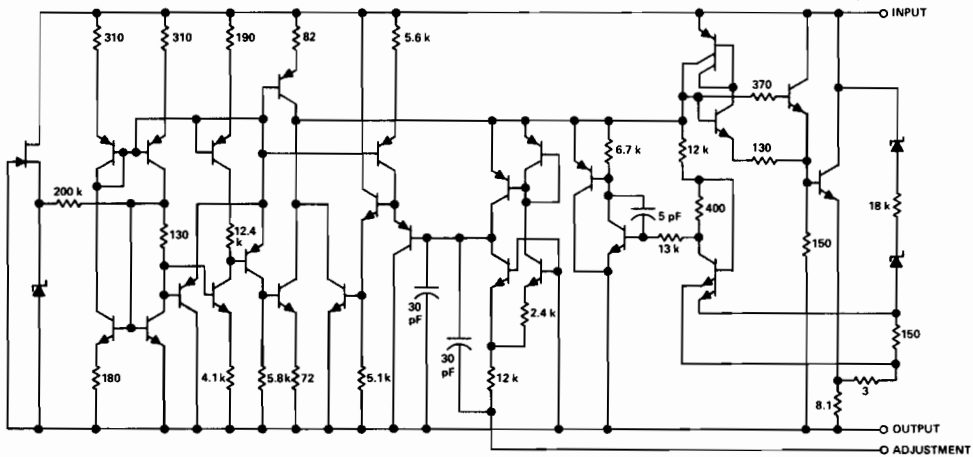

All resistors values shown are nominal and in ohms.

absolute maximum ratings over operation temperature range (unless otherwise noted)

	LM117	LM217	LM317	UNIT
Input-to-output differential voltage, $V_I - V_O$	40	40	40	V
Continuous total dissipation at 25°C free-air temperature (see Note 1)	KC (TO-220AB) package	2000	2000	mW
	KD (TO-202AB) package	1575	1575	
	LA package	600	600	
Continuous total dissipation at (or below) 25°C case temperature (see Note 1)	KC package	20	20	W
	KD package	2	2	
	LA package	2	2	
Operating free-air, case, or virtual junction temperature range	-55 to 150	-25 to 150	0 to 150	°C
Storage temperature range	-65 to 150	-65 to 150	-65 to 150	°C
Lead temperature 1/16 inch from case for 10 seconds		260	260	°C
Lead temperature 1/16 inch from case for 60 seconds	300	300	300	°C

NOTE 1: For operation above 25°C free-air or case temperature, refer to Dissipation Derating Curves, Figures 15 through 18, page 104.

recommended operating conditions

		LM117		LM217		LM317		UNIT
		MIN	MAX	MIN	MAX	MIN	MAX	
Output current, I_O	All packages	5		5		10		mA
	KC package				1500		1500	
	KD package				500		500	
	LA package		500		500		500	
Operating virtual junction temperature, T_J		-55	150	-25	150	0	125	°C

TYPES LM117, LM217, LM317

3-TERMINAL ADJUSTABLE REGULATORS

electrical characteristics over recommended ranges of operation virtual junction temperature
(unless otherwise noted)

PARAMETER	TEST CONDITIONS†		LM117, LM217			LM317			UNIT	
			MIN	TYP	MAX	MIN	TYP	MAX		
Input regulation‡	$V_I - V_O = 3\text{ V to }40\text{ V}$, See Note 2		$T_J = 25^\circ\text{C}$			0.01	0.02	0.01	0.04	% / V
			$I_O = 10\text{ mA to MAX}$			0.02	0.05	0.02	0.07	
Ripple rejection	$V_O = 10\text{ V}$, $f = 120\text{ Hz}$		65			65			dB	
	$V_O = 10\text{ V}$, $f = 120\text{ Hz}$ 10- μF capacitor between ADJ and ground		66	80		66	80			
Output regulation	$I_O = 10\text{ mA to MAX}$, $T_J = 25^\circ\text{C}$, See Note 2	$V_O \leq 5\text{ V}$	LA package	*		*		mV		
			KC and KD packages	5	15	5	25			
		$V_O > 5\text{ V}$	LA package	*		*		%		
			KC and KD packages	0.1	0.3	0.1	0.5			
	$I_O = 10\text{ mA to MAX}$, See Note 2	$V_O \leq 5\text{ V}$	LA package	*		*		mV		
			KC and KD packages	20	50	20	70			
$V_O > 5\text{ V}$	LA package	*		*		%				
	KC and KD packages	0.3	1	0.3	1.5					
Output voltage change with temperature	$T_J = \text{MIN to MAX}$		1			1			%	
Output voltage long-term drift (see Note 3)	After 1000 h at $T_J = \text{MAX}$ and $V_I - V_O = 40\text{ V}$		0.3			1			%	
Output noise voltage	$f = 10\text{ Hz to }10\text{ kHz}$, $T_J = 25^\circ\text{C}$		0.003			0.003			%	
Minimum output current to maintain regulation	$V_I - V_O = 40\text{ V}$		3.5			5			mA	
Peak output current	$V_I - V_O \leq 15\text{ V}$		KC package	1.5	2.2	1.5	2.2	A		
			KD and LA packages	0.5	0.8	0.5	0.8			
	$V_I - V_O \leq 40\text{ V}$		KC package	0.4		0.4				
			KD and LA packages	0.07		0.07				
Adjustment-terminal current			50			100			μA	
Change in adjustment-terminal current	$V_I - V_O = 2.5\text{ V to }40\text{ V}$, $I_O = 10\text{ mA to MAX}$		0.2			5			μA	
Reference voltage (output to ADJ)	$V_I - V_O = 3\text{ V to }40\text{ V}$, $I_O = 10\text{ mA to MAX}$, $P \leq \text{rated dissipation}$		1.2	1.25	1.3	1.2	1.25	1.3	V	

† Unless otherwise noted, these specifications apply for the following test conditions: $V_I - V_O = 5\text{ V}$ and $I_O = 5\text{ A}$ for the KC (TO-220AB) package and $I_O = 0.1\text{ A}$ for the LA and KD (TO-202AB) packages. For conditions shown as MIN or MAX, use the appropriate value specified under recommended operating conditions.

‡ Input regulation is expressed here as the percentage change in output voltage per 1-volt change at the input.

NOTES: 2. Input regulation and output regulation are measured using pulse techniques ($t_w \leq 10\ \mu\text{s}$, duty cycle $\leq 5\%$) to limit changes in average internal dissipation. Output voltage changes due to large changes in internal dissipation must be taken into account separately.

3. Since long-term drift cannot be measured on the individual devices prior to shipment, this specification is not intended to be a guarantee or warranty. It is an engineering estimate of the average drift to be expected from lot to lot.

* These specifications for this product in the LA package have not been determined. It is planned to specify values where asterisks appear above.

TYPES LM117, LM217, LM317

3-TERMINAL ADJUSTABLE REGULATORS

TYPICAL APPLICATION DATA

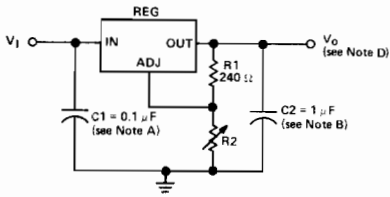

FIGURE 1—ADJUSTABLE VOLTAGE REGULATOR

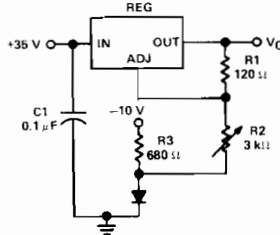
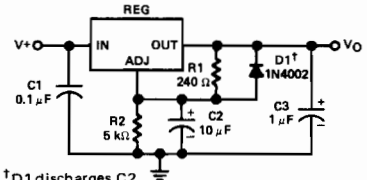

FIGURE 2—0-V to 30-V REGULATOR CIRCUIT



† D1 discharges C2 if output is shorted to ground.

FIGURE 3—ADJUSTABLE REGULATOR CIRCUIT WITH IMPROVED RIPPLE REJECTION

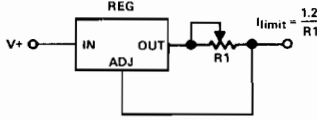

FIGURE 4—PRECISION CURRENT LIMITER CIRCUIT

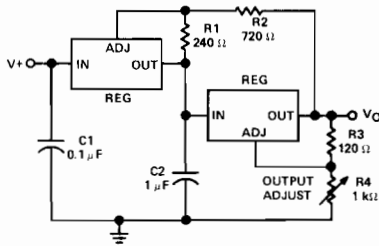

FIGURE 5—TRACKING PREREGULATOR CIRCUIT

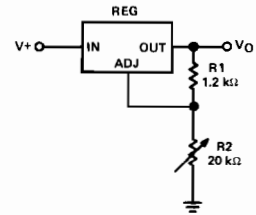

FIGURE 6—1.2 to 20-V REGULATOR CIRCUIT WITH MINIMUM PROGRAM CURRENT

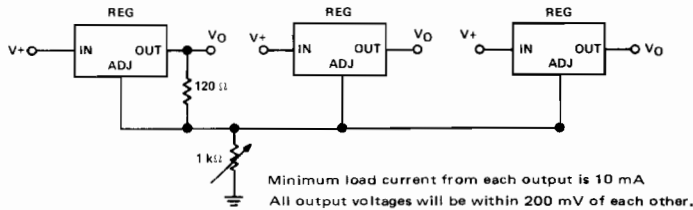

FIGURE 7—ADJUSTING MULTIPLE ON-CARD REGULATORS WITH A SINGLE CONTROL

NOTES: A. Use of an input bypass capacitor is recommended if regulator is far from filter capacitors.

B. Use of an output capacitor improves transient response but is optional.

C. V_{ref} equals the difference between the output and adjustment terminal voltages.

D. Output voltage is calculated from the equation: $V_O = V_{ref} \left(1 + \frac{R_2}{R_1} \right)$

TYPES LM117, LM217, LM317

3-TERMINAL ADJUSTABLE REGULATORS

TYPICAL APPLICATIONS

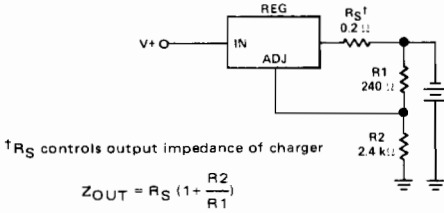

$$Z_{OUT} = R_S \left(1 + \frac{R_2}{R_1}\right)$$

The use of R_S allows low charging rates with a fully-charged battery.

FIGURE 8—BATTERY CHARGER CIRCUIT

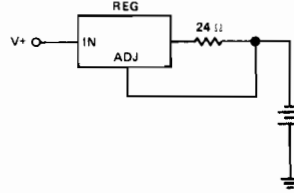

FIGURE 9—50-mA CONSTANT-CURRENT BATTERY CHARGER CIRCUIT

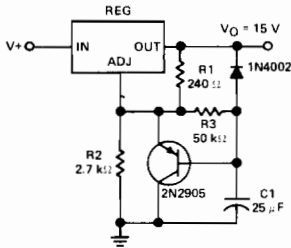

FIGURE 10—SLOW-TURN-ON 15-V REGULATOR CIRCUIT

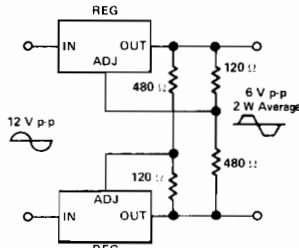

FIGURE 11—A-C VOLTAGE REGULATOR CIRCUIT

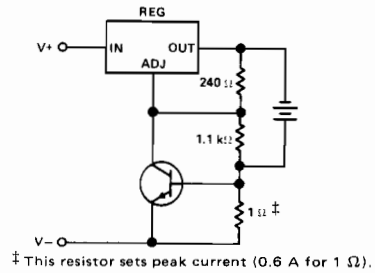

FIGURE 12—CURRENT-LIMITED 6-V CHARGER

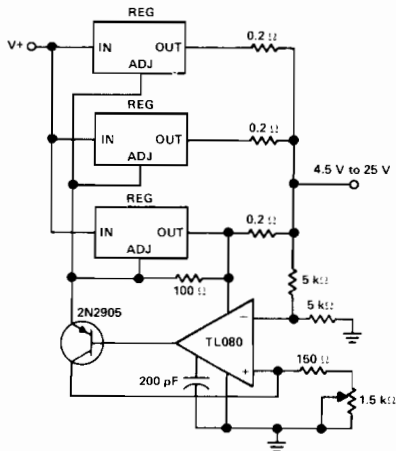

FIGURE 13—ADJUSTABLE 4-A REGULATOR

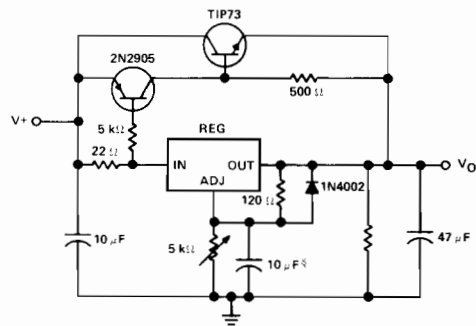

FIGURE 14—HIGH-CURRENT ADJUSTABLE REGULATOR

TYPES LM117, LM217, LM317

3-TERMINAL ADJUSTABLE REGULATORS

THERMAL INFORMATION

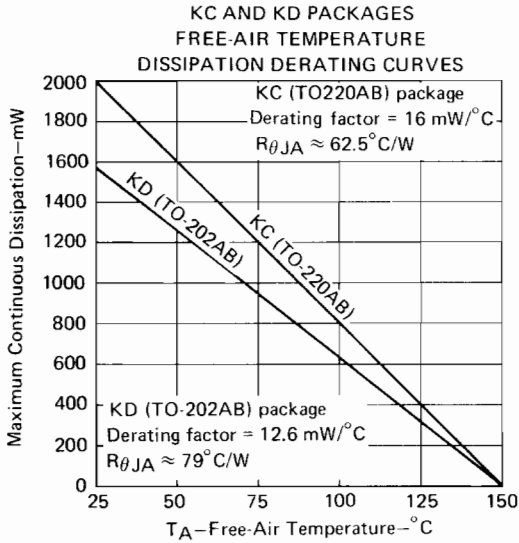

FIGURE 15

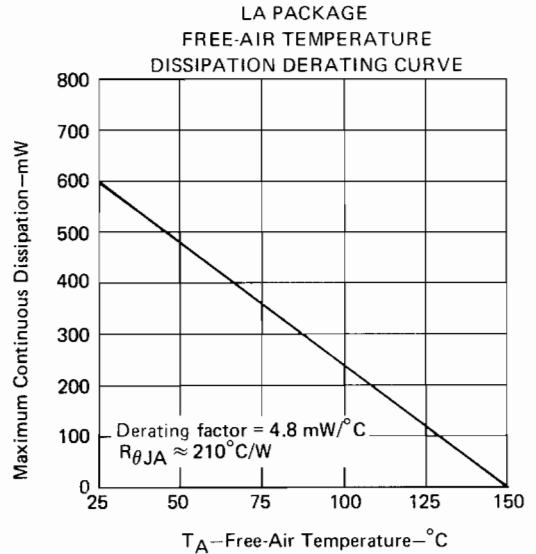

FIGURE 16

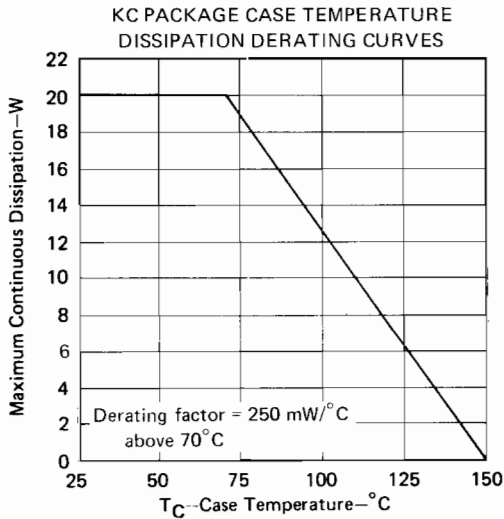

FIGURE 17

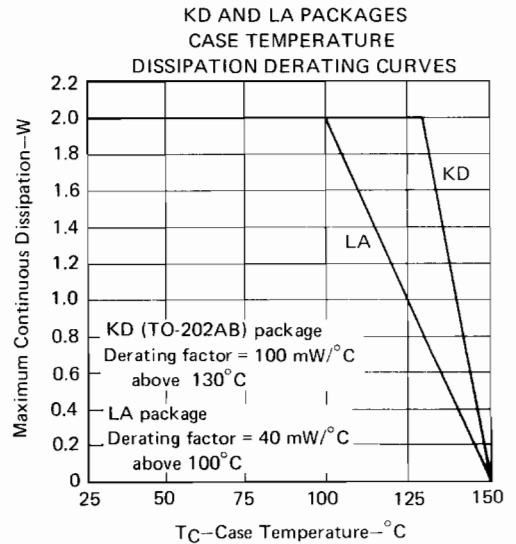

FIGURE 18

LINEAR INTEGRATED CIRCUITS

SERIES LM340 POSITIVE-VOLTAGE REGULATORS

BULLETIN NO. DL-S 12503, SEPTEMBER 1977

- 3-Terminal Regulators
- Output Current up to 1.5 A
- No External Components
- Internal Thermal Overload Protection
- Direct Replacements for National LM340 Series
- High Power Dissipation Capability
- Internal Short-Circuit Current Limiting
- Output Transistor Safe-Area Compensation

NOMINAL OUTPUT VOLTAGE	TOLERANCE ≈10%	TOLERANCE ≈5%
5 V	LM340KC-5	LM340KC-5R
6 V	LM340KC-6	LM340KC-6R
8 V	LM340KC-8	LM340KC-8R
10 V	LM340KC-10	LM340KC-10R
12 V	LM340KC-12	LM340KC-12R
15 V	LM340KC-15	LM340KC-15R
18 V	LM340KC-18	LM340KC-18R
24 V	LM340KC-24	LM340KC-24R

description

This series of fixed-voltage monolithic integrated-circuit voltage regulators is designed for a wide range of applications. These applications include on-card regulation for elimination of noise and distribution problems associated with single-point regulation. One of these regulators can deliver up to 1.5 amperes of output current. The internal current limiting and thermal shutdown features of these regulators make them essentially immune to overload. In addition to use as fixed-voltage regulators, these devices can be used with external components to obtain adjustable output voltages and currents and also as the power-pass element in precision regulators.

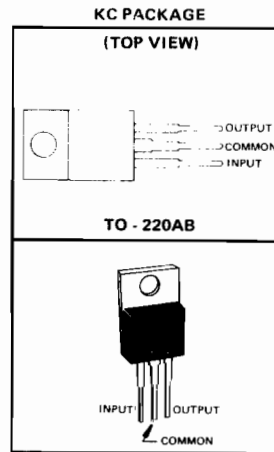

schematic

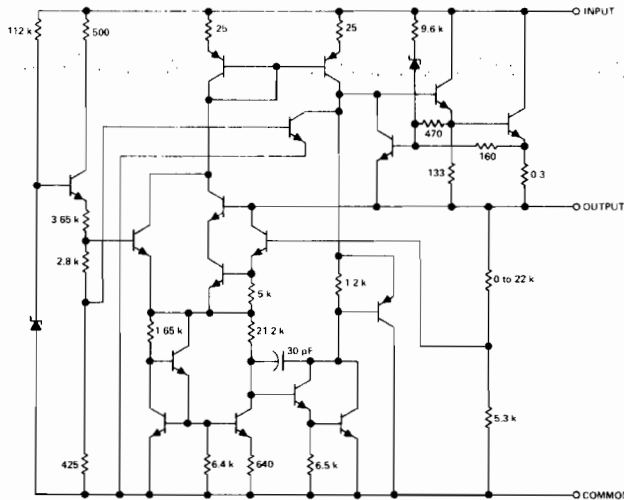

Resistor values shown are nominal and in ohms.

Copyright © 1977 by Texas Instruments Incorporated

TEXAS INSTRUMENTS
INCORPORATED
POST OFFICE BOX 5012 • DALLAS, TEXAS 75222

SERIES LM340

POSITIVE-VOLTAGE REGULATORS

absolute maximum ratings over operating temperature range (unless otherwise noted)

Input voltage: LM340-24, LM340-24R	40 V
All others	35 V
Continuous total dissipation at 25°C free-air temperature (see Note 1)	2 W
Continuous total dissipation at (or below) 25°C case temperature (see Note 1)	15 W
Operating free-air, case, or virtual junction temperature range	0°C to 150°C
Storage temperature range	-65°C to 150°C
Lead temperature 1/16 inch from case for 10 seconds	260°C

NOTE 1: For operation above 25°C free-air or case temperature, refer to Dissipation Derating Curves, Figure 1 and 2.

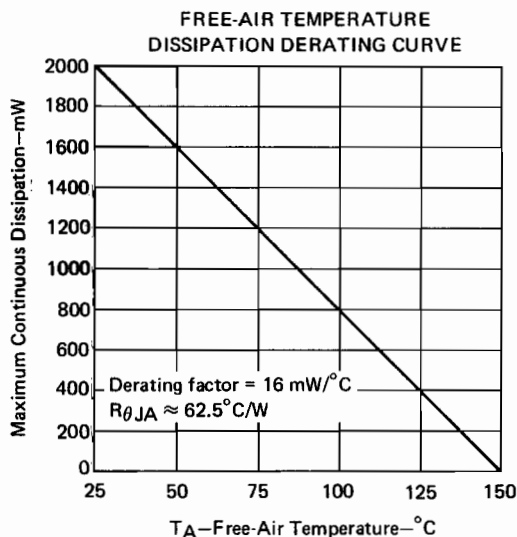

FIGURE 1

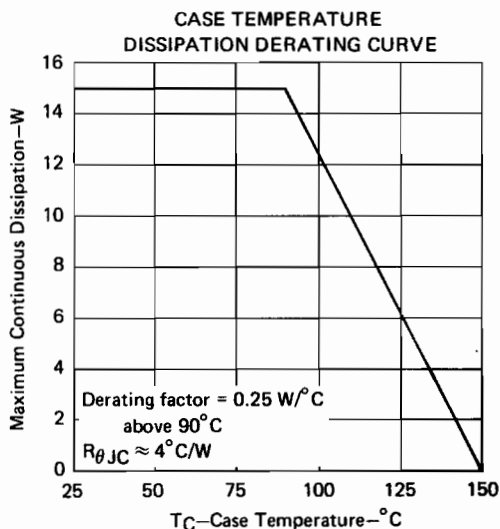

FIGURE 2

recommended operating conditions

		MIN	MAX	UNIT
Input voltage, V_I	LM340-5, LM340-5R	7	25	V
	LM340-6, LM340-6R	8	25	
	LM340-8, LM340-8R	10.5	25	
	LM340-10, LM340-10R	12.5	25	
	LM340-12, LM340-12R	14.5	30	
	LM340-15, LM340-15R	17.5	30	
	LM340-18, LM340-18R	21	33	
	LM340-24, LM340-24R	27	38	
Output current, I_O	LM340-5 thru LM340-15, LM340-5R thru LM340-15R	1.5		A
	LM340-18, LM340-18R, LM340-24, LM340-24R	1		
Operating virtual junction temperature, T_J		0	150	°C

SERIES LM340 POSITIVE-VOLTAGE REGULATORS

**LM340-5, LM340-5R electrical characteristics at 25°C virtual junction temperature,
V_I = 10 V, I_O = 500 mA (unless otherwise noted)**

PARAMETER	TEST CONDITIONS†		LM340-5			LM340-5R			UNIT
			MIN	TYP	MAX	MIN	TYP	MAX	
Output voltage	I _O = 5 mA to 1 A, P < 15 W, T _A = 0°C to 70°C	V _I = 7 V to 20 V	4.8	5	5.2	4.6	5	5.4	V
		V _I = 7.7 V to 20 V	4.75		5.25			5.5	
Input regulation	V _I = 7 V to 25 V	I _O = 100 mA			50				mV
		I _O = 500 mA			100				
	V _I = 7.4 V to 25 V	I _O = 100 mA						75	
		I _O = 500 mA						150	
Ripple rejection	f = 120 Hz, T _A = 0°C to 70°C		60			58		dB	
Output regulation	I _O = 5 mA to 1.5 A			100			140	mV	
Output voltage long-term drift (see Note 2)	After 1000 h at T _J and V _I - V _O both at maximum rated values			20		15		mV	
Output noise voltage	f = 10 Hz to 100 kHz			40		50		μV	
Bias current				7	10		8	12	mA
Bias current change	T _A = 0°C to 70°C	I _O = 5 mA to 1.5 A			0.5		0.4		mA
		V _I = 7 V to 25 V			1.3				
		V _I = 7.7 V to 25 V					1		

**LM340-6, LM340-6R electrical characteristics at 25°C virtual junction temperature,
V_I = 11 V, I_O = 500 mA (unless otherwise noted)**

PARAMETER	TEST CONDITIONS†		LM340-6			LM340-6R			UNIT
			MIN	TYP	MAX	MIN	TYP	MAX	
Output voltage	I _O = 5 mA to 1 A, P < 15 W, T _A = 0°C to 70°C	V _I = 8 V to 21 V	5.75	6	6.25	5.5	6	6.5	V
		V _I = 8.8 V to 21 V	5.7		6.3	5.4		6.6	
Input regulation	V _I = 8 V to 25 V	I _O = 100 mA			60				mV
		I _O = 500 mA			120				
	V _I = 8.5 V to 25 V	I _O = 100 mA						80	
		I _O = 500 mA						160	
Ripple rejection	f = 120 Hz, T _A = 0°C to 70°C		57			55		dB	
Output regulation	I _O = 5 mA to 1.5 A			120			160	mV	
Output voltage long-term drift (see Note 2)	After 1000 h at T _J and V _I - V _O both at maximum rated values			24		18		mV	
Output noise voltage	f = 10 Hz to 100 kHz			45		55		μV	
Bias current				7	10		8	12	mA
Bias current change	T _A = 0°C to 70°C	I _O = 5 mA to 1.5 A			0.5		0.4		mA
		V _I = 8 V to 25 V			1.3				
		V _I = 8.8 V to 25 V					1		

† All characteristics are measured with a capacitor across the input of 0.33 μF and a capacitor across the output of 0.1 μF. All characteristics except noise voltage and ripple rejection ratio are measured using pulse techniques (t_w < 10 ms, duty cycles < 5%). Output voltage changes due to changes in internal temperature must be taken into account separately.

NOTE 2: Since long-term drift cannot be measured on the individual devices prior to shipment, this specification is not intended to be a guarantee or warranty. It is an engineering estimate of the average drift to be expected from lot to lot.

SERIES LM340

POSITIVE-VOLTAGE REGULATORS

LM340-8, LM340-8R electrical characteristics at 25°C virtual junction temperature,
 $V_I = 14\text{ V}$, $I_O = 500\text{ mA}$ (unless otherwise noted)

PARAMETER	TEST CONDITIONS†		LM340-8			LM340-8R			UNIT
			MIN	TYP	MAX	MIN	TYP	MAX	
Output voltage	$I_O = 5\text{ mA to }1\text{ A}$, $P \leq 15\text{ W}$, $T_A = 0^\circ\text{C to }70^\circ\text{C}$	$V_I = 10.5\text{ V to }23\text{ V}$	7.7	8	8.3	7.36	8	8.64	V
		$V_I = 11\text{ V to }23\text{ V}$	7.6		8.4				
							7.2		
Input regulation	$V_I = 10.5\text{ V to }25\text{ V}$	$I_O = 100\text{ mA}$			80				mV
		$I_O = 500\text{ mA}$			160				
	$V_I = 10.7\text{ V to }25\text{ V}$	$I_O = 100\text{ mA}$						110	
		$I_O = 500\text{ mA}$						210	
Ripple rejection	$f = 120\text{ Hz}$,	$T_A = 0^\circ\text{C to }70^\circ\text{C}$		55		53		dB	
Output regulation	$I_O = 5\text{ mA to }1.5\text{ A}$				160		210	mV	
Output voltage long-term drift (see Note 2)	After 1000 h at T_J and $V_I - V_O$ both at maximum rated values				32		24	mV	
Output noise voltage	$f = 10\text{ Hz to }100\text{ kHz}$			52		62		μV	
Bias current				7	10		8	12	mA
Bias current change	$T_A = 0^\circ\text{C to }70^\circ\text{C}$	$I_O = 5\text{ mA to }1.5\text{ A}$			0.5		0.4		mA
		$V_I = 10.5\text{ V to }25\text{ V}$			1.3				
		$V_I = 11\text{ V to }25\text{ V}$					1		

LM340-10, LM340-10R electrical characteristics at 25°C virtual junction temperature,
 $V_I = 17\text{ V}$, $I_O = 500\text{ mA}$ (unless otherwise noted)

PARAMETER	TEST CONDITIONS†		LM340-10			LM340-10R			UNIT
			MIN	TYP	MAX	MIN	TYP	MAX	
Output voltage	$I_O = 5\text{ mA to }1\text{ A}$, $P \leq 15\text{ W}$, $T_A = 0^\circ\text{C to }70^\circ\text{C}$	$V_I = 12.5\text{ V to }25\text{ V}$	9.6	10	10.4	9.2	10	10.8	V
		$V_I = 13.2\text{ V to }25\text{ V}$	9.5		10.5				
							9		
Input regulation	$V_I = 12.5\text{ V to }25\text{ V}$	$I_O = 100\text{ mA}$			100				mV
		$I_O = 500\text{ mA}$			200				
	$V_I = 13\text{ V to }25\text{ V}$	$I_O = 100\text{ mA}$						140	
		$I_O = 500\text{ mA}$						270	
Ripple rejection	$f = 120\text{ Hz}$,	$T_A = 0^\circ\text{C to }70^\circ\text{C}$		54		51		dB	
Output regulation	$I_O = 5\text{ mA to }1.5\text{ A}$				200		270	mV	
Output voltage long-term drift (see Note 2)	After 1000 h at T_J and $V_I - V_O$ both at maximum rated values				40		30	mV	
Output noise voltage	$f = 10\text{ Hz to }100\text{ kHz}$			70		80		μV	
Bias current				7	10		8	12	mA
Bias current change	$T_A = 0^\circ\text{C to }70^\circ\text{C}$	$I_O = 5\text{ mA to }1.5\text{ A}$			0.5		0.4		mA
		$V_I = 12.5\text{ V to }25\text{ V}$			1.3				
		$V_I = 13.2\text{ V to }25\text{ V}$					1		

† All characteristics are measured with a capacitor across the input of 0.33 μF and a capacitor across the output of 0.1 μF . All characteristics except noise voltage and ripple rejection ratio are measured using pulse techniques ($t_w \leq 10\text{ ms}$, duty cycles $\leq 5\%$). Output voltage changes due to changes in internal temperature must be taken into account separately.

NOTE 2: Since long-term drift cannot be measured on the individual devices prior to shipment, this specification is not intended to be a guarantee or warranty. It is an engineering estimate of the average drift to be expected from lot to lot.

SERIES LM340 POSITIVE-VOLTAGE REGULATORS

LM340-12, LM340-12R electrical characteristics at 25°C virtual junction temperature,
V_I = 19 V, I_O = 500 mA (unless otherwise noted)

PARAMETER	TEST CONDITIONS†		LM340-12			LM340-12R			UNIT
			MIN	TYP	MAX	MIN	TYP	MAX	
Output voltage	I _O = 5 mA to 1 A, P ≤ 15 W, T _A = 0°C to 70°C		11.5 12 12.5			11 12 13			V
			V _I = 14.5 V to 27 V		11.4 12.6				
			V _I = 15.3 V to 27 V				10.8 13.2		
Input regulation	V _I = 14.5 V to 30 V		I _O = 100 mA			120			mV
			I _O = 500 mA			240			
	V _I = 15 V to 30 V		I _O = 100 mA			160			
			I _O = 500 mA			320			
Ripple rejection	f = 120 Hz, T _A = 0°C to 70°C		52			50			dB
Output regulation	I _O = 5 mA to 1.5 A		240			320			mV
Output voltage long-term drift (see Note 2)	After 1000 h at T _J and V _I - V _O both at maximum rated values		48			36			mV
Output noise voltage	f = 10 Hz to 100 kHz		75			85			μV
Bias current			7 10			8 12			mA
Bias current change	T _A = 0°C to 70°C		I _O = 5 mA to 1.5 A			0.5			mA
			V _I = 14.5 V to 30 V		1.3				
			V _I = 15.3 V to 30 V		1				

LM340-15, LM340-15R electrical characteristics at 25°C virtual junction temperature,
V_I = 23 V, I_O = 500 mA (unless otherwise noted)

PARAMETER	TEST CONDITIONS†		LM340-15			LM340-15R			UNIT
			MIN	TYP	MAX	MIN	TYP	MAX	
Output voltage	I _O = 5 mA to 1 A, P ≤ 15 W, T _A = 0°C to 70°C		14.4 15 15.6			13.8 15 16.2			V
			V _I = 17.5 V to 30 V		14.25 15.75				
			V _I = 18.6 V to 30 V				13.5 16.5		
Input regulation	V _I = 17.5 V to 30 V		I _O = 100 mA			150			mV
			I _O = 500 mA			300			
	V _I = 18.2 V to 30 V		I _O = 100 mA			200			
			I _O = 500 mA			400			
Ripple rejection	f = 120 Hz, T _A = 0°C to 70°C		50			48			dB
Output regulation	I _O = 5 mA to 1.5 A		300			400			mV
Output voltage long-term drift (see Note 2)	After 1000 h at T _J and V _I - V _O both at maximum rated values		60			45			mV
Output noise voltage	f = 10 Hz to 100 kHz		90			100			μV
Bias current			7 10			8 12			mA
Bias current change	T _A = 0°C to 70°C		I _O = 5 mA to 1.5 A			0.5			mA
			V _I = 17.5 V to 30 V		1.3				
			V _I = 18.6 V to 30 V		1				

† All characteristics are measured with a capacitor across the input of 0.33 μF and a capacitor across the output of 0.1 μF. All characteristics except noise voltage and ripple rejection ratio are measured using pulse techniques (t_w ≤ 10 ms, duty cycles ≤ 5%). Output voltage changes due to changes in internal temperature must be taken into account separately.

NOTE 2: Since long-term drift cannot be measured on the individual devices prior to shipment, this specification is not intended to be a guarantee or warranty. It is an engineering estimate of the average drift to be expected from lot to lot.

SERIES LM340

POSITIVE-VOLTAGE REGULATORS

LM340-18, LM340-18R electrical characteristics at 25°C virtual junction temperature,
 $V_I = 27\text{ V}$, $I_O = 500\text{ mA}$ (unless otherwise noted)

PARAMETER	TEST CONDITIONS†		LM340-18			LM340-18R			UNIT
			MIN	TYP	MAX	MIN	TYP	MAX	
Output voltage	$I_O = 5\text{ mA to }1\text{ A}$, $P < 15\text{ W}$, $T_A = 0^\circ\text{C to }70^\circ\text{C}$	$V_I = 21\text{ V to }33\text{ V}$	17.3	18	18.7	16.6	18	19.4	V
		$V_I = 22\text{ V to }33\text{ V}$	17.1		18.9			19.8	
						16.2		19.8	
Input regulation	$V_I = 21\text{ V to }33\text{ V}$	$I_O = 100\text{ mA}$			180				mV
		$I_O = 500\text{ mA}$			360				
							240		
	$V_I = 21.4\text{ V to }33\text{ V}$	$I_O = 100\text{ mA}$					480		
		$I_O = 500\text{ mA}$					480		
Ripple rejection	$f = 120\text{ Hz}$,	$T_A = 0^\circ\text{C to }70^\circ\text{C}$		48			46		dB
Output regulation	$I_O = 5\text{ mA to }1\text{ A}$				360		480		mV
Output voltage long-term drift (see Note 2)	After 1000 h at T_J and $V_I - V_O$ both at maximum rated values				72		54		mV
Output noise voltage	$f = 10\text{ Hz to }100\text{ kHz}$			110			120		μV
Bias current				7	10		8	12	mA
Bias current change	$T_A = 0^\circ\text{C to }70^\circ\text{C}$	$I_O = 5\text{ mA to }1\text{ A}$			0.5		0.4		
		$V_I = 21\text{ V to }33\text{ V}$			1.3				
		$V_I = 22\text{ V to }33\text{ V}$					1		

LM340-24, LM340-24R electrical characteristics at 25°C virtual junction temperature,
 $V_I = 33\text{ V}$, $I_O = 500\text{ mA}$ (unless otherwise noted)

PARAMETER	TEST CONDITIONS†		LM340-24			LM340-24R			UNIT
			MIN	TYP	MAX	MIN	TYP	MAX	
Output voltage	$I_O = 5\text{ mA to }1\text{ A}$, $P < 15\text{ W}$, $T_A = 0^\circ\text{C to }70^\circ\text{C}$	$V_I = 27\text{ V to }38\text{ V}$	23	24	25	22	24	26	V
		$V_I = 28.5\text{ V to }38\text{ V}$	22.8		25.2	21.6		26.4	
Input regulation	$V_I = 27\text{ V to }38\text{ V}$	$I_O = 100\text{ mA}$			240				mV
		$I_O = 500\text{ mA}$			480				
							320		
	$V_I = 28\text{ V to }38\text{ V}$	$I_O = 100\text{ mA}$					640		
		$I_O = 500\text{ mA}$					640		
Ripple rejection	$f = 120\text{ Hz}$,	$T_A = 0^\circ\text{C to }70^\circ\text{C}$		44			42		dB
Output regulation	$I_O = 5\text{ mA to }1\text{ A}$				480		640		mV
Output voltage long-term drift (see Note 2)	After 1000 h at T_J and $V_I - V_O$ both at maximum rated values				96		72		mV
Output noise voltage	$f = 10\text{ Hz to }100\text{ kHz}$			170			180		μV
Bias current				7	10		8	12	mA
Bias current change	$T_A = 0^\circ\text{C to }70^\circ\text{C}$	$I_O = 5\text{ mA to }1\text{ A}$			0.5		0.4		mA
		$V_I = 27\text{ V to }38\text{ V}$			1.3				
		$V_I = 28.5\text{ V to }38\text{ V}$					1		

† All characteristics are measured with a capacitor across the input of 0.33 μF and a capacitor across the output of 0.1 μF . All characteristics except noise voltage and ripple rejection ratio are measured using pulse techniques ($t_w \leq 10\text{ ms}$, duty cycles $\leq 5\%$). Output voltage changes due to changes in internal temperature must be taken into account separately.

NOTE 2: Since long-term drift cannot be measured on the individual devices prior to shipment, this specification is not intended to be a guarantee or warranty. It is an engineering estimate of the average drift to be expected from lot to lot.

SERIES LM340 POSITIVE-VOLTAGE REGULATORS

TYPICAL CHARACTERISTICS

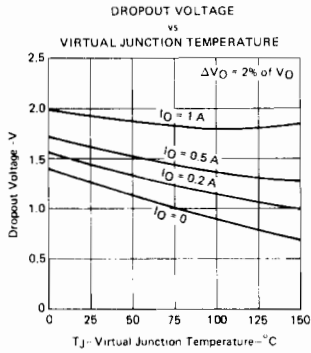

FIGURE 3

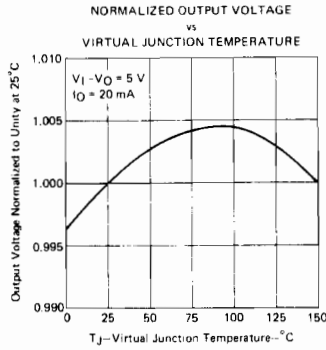

FIGURE 4

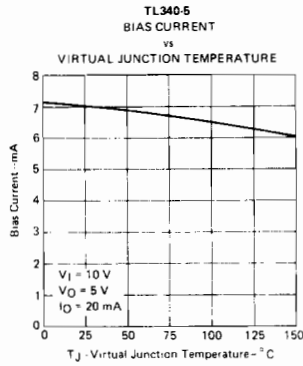

FIGURE 5

TYPICAL APPLICATION DATA

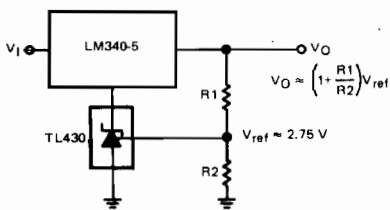

FIGURE 6—ADJUSTABLE SUPPLY WITH STABLE OUTPUT FROM 8 VOLTS TO 35 VOLTS

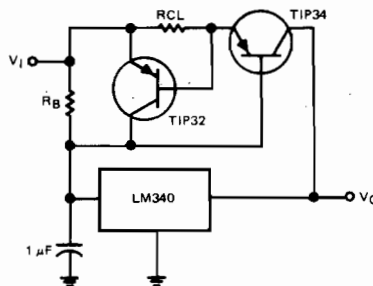

FIGURE 7—OUTPUT CURRENT BOOST CIRCUIT

The boost circuit takes over at a level determined by R_B .

$$R_B \approx \frac{0.6 \text{ V}}{I_B}$$

where I_B is the LM340 operating level.

Maximum current limit I_{CL} is determined by R_{CL} .

$$R_{CL} \approx \frac{0.6 \text{ V}}{I_{CL}}$$

Example: If I_B is selected to be 0.5 A, then
 $R_B = 1.2 \Omega$.
 If I_{CL} is 3 A, then
 $R_{CL} = 0.2 \Omega$.

LINEAR INTEGRATED CIRCUITS REGULATING PULSE WIDTH MODULATORS

BULLETIN NO. DL-S 12495, APRIL 1977

- Complete PWM Power Control Circuitry
- Uncommitted Outputs for Single-Ended or Push-Pull Applications
- Low Standby Current . . . 8 mA Typ
- Interchangeable With Silicon General SG1524, SG2524, and SG3524, Respectively

description

The SG1524, SG2524, and SG3524 incorporate on single monolithic chips all the functions required in the construction of a regulating power supply, inverter, or switching regulator. They can also be used as the control element for high-power-output applications. The SG1524 family was designed for switching regulators of either polarity, transformer-coupled dc-to-dc converters, transformerless voltage doublers, and polarity converter applications employing fixed-frequency, pulse-width-modulation techniques. The complementary output allows either single-ended or push-pull application. Each device includes an on-chip regulator, error amplifier, programmable oscillator, pulse-steering flip-flop, two uncommitted pass transistors, a high-gain comparator, and current-limiting and shut-down circuitry.

SG1524 . . . J
SG2524, SG3524 . . . J OR N
DUAL-IN-LINE PACKAGE (TOP VIEW)

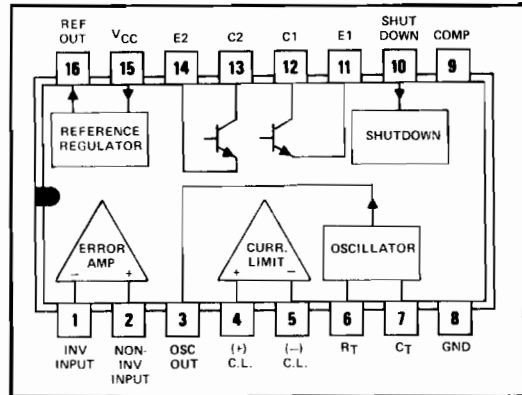

The SG1524 is characterized for operation over the full military temperature range of -55°C to 125°C . The SG2524 and SG3524 are characterized for operation from 0°C to 70°C .

functional block diagram

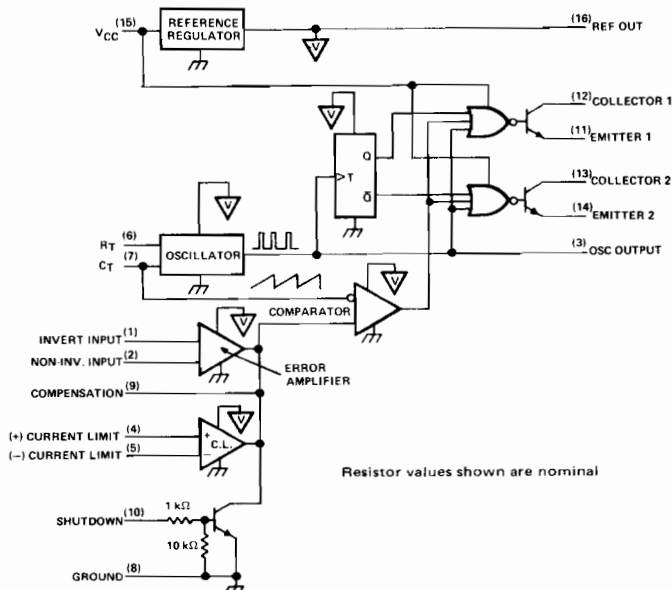

Copyright © 1977 by Texas Instruments Incorporated

TYPES SG1524, SG2524, SG3524

REGULATING PULSE WIDTH MODULATORS

absolute maximum ratings over operating free-air temperature range (unless otherwise noted)

Supply Voltage, V_{CC} (See Notes 1 and 2)	40 V
Collector Output Current	100 mA
Reference Output Current	50 mA
Current Through C_T Terminal	-5 mA
Continuous Total Dissipation at (or below) 25°C Free-Air Temperature (See Note 3)	1000 mW
Operating Free-Air Temperature Range: SG1524	-55°C to 125°C
SG2524, SG3524	0°C to 70°C
Storage Temperature Range	-65°C to 150°C

- NOTES: 1. All voltage values are with respect to network ground terminal.
 2. The reference regulator may be bypassed for operation from a fixed 5-volt supply by connecting the V_{CC} and reference output pins both to the supply voltage. In this configuration the maximum supply voltage is 6 volts.
 3. For operation above 25°C free-air temperature, see Dissipation Derating Curves, page 124.

recommended operating conditions

	SG1524		SG2524, SG3524		UNIT
	MIN	MAX	MIN	MAX	
Supply voltage, V_{CC}	8	40	8	40	V
Reference output current	0	50	0	50	mA
Current thru C_T terminal	-0.03	-2	-0.03	-2	mA
Timing resistor, R_T	1.8	100	1.8	100	k Ω
Timing capacitor, C_T	0.001	0.1	0.001	0.1	μ F
Operating free-air temperature	-55	125	0	70	°C

electrical characteristics over recommended operating free-air temperature range, $V_{CC} = 20$ V, $f = 20$ kHz (unless otherwise noted)

reference section

PARAMETER	TEST CONDITIONS [†]	SG1524			SG2524			SG3524			UNIT
		MIN	TYP [‡]	MAX	MIN	TYP [‡]	MAX	MIN	TYP [‡]	MAX	
Output voltage		4.8	5	5.2	4.8	5	5.2	4.6	5	5.4	V
Input regulation	$V_{CC} = 8$ to 40 V		10	20		10	20		10	30	mV
Ripple rejection	$f = 120$ Hz		66			66			66		dB
Output regulation	$I_O = 0$ to 20 mA		20	50		20	50		20	50	mV
Output voltage change with temperature	$T_A = \text{MIN to MAX}$		0.6	2		0.3	1		0.3	1	%
Short-circuit output current \S	$V_{ref} = 0$		100			100			100		mA

[†] For conditions shown as MIN or MAX, use the appropriate value specified under recommended operating conditions.

[‡] All typical values except output voltage change with temperature are at $T_A = 25^\circ\text{C}$.

^{\S} Duration of the short-circuit should not exceed one second.

TYPES SG1524, SG2524, SG3524 REGULATING PULSE WIDTH MODULATORS

electrical characteristics over recommended operating free-air temperature range, $V_{CC} = 20\text{ V}$, $f = 20\text{ kHz}$ (unless otherwise noted)

error amplifier section

PARAMETER	TEST CONDITIONS	SG1524, SG2524			SG3524			UNIT
		MIN	TYP [‡]	MAX	MIN	TYP [‡]	MAX	
Input offset voltage	$V_{IC} = 2.5\text{ V}$		0.5	5		2	10	mV
Input bias current	$V_{IC} = 2.5\text{ V}$		2	10		2	10	μA
Open-loop voltage amplification		72	80		60	80		dB
Common-mode input voltage range	$T_A = 25^\circ\text{C}$	1.8 to 3.4			1.8 to 3.4			V
Common-mode rejection ratio			70			70		dB
Unity-gain bandwidth			3			3		MHz
Output swing	$T_A = 25^\circ\text{C}$	0.5		3.8	0.5		3.8	V

oscillator section

PARAMETER	TEST CONDITIONS [†]	MIN	TYP [‡]	MAX	UNIT
Frequency	$C_T = 0.001\ \mu\text{F}$, $R_T = 2\ \text{k}\Omega$		450		kHz
Standard deviation of frequency §	All values of voltage, temperature, resistance, and capacitance constant		5		%
Frequency change with voltage	$V_{CC} = 8\text{ to }40\text{ V}$, $T_A = 25^\circ\text{C}$			1	%
Frequency change with temperature	$T_A = \text{MIN to MAX}$			2	%
Output amplitude at pin 3			3.5		V
Output pulse width at pin 3	$C_T = 0.01\ \mu\text{F}$		0.5		μs

comparator section

PARAMETER	TEST CONDITIONS	MIN	TYP [‡]	MAX	UNIT
Maximum duty cycle, each output		45			%
Input threshold voltage at pin 9	Zero duty cycle		1		V
	Maximum duty cycle		3.5		
Input bias current			-1		μA

current limiting section

PARAMETER	TEST CONDITIONS	SG1524, SG2524			SG3524			UNIT
		MIN	TYP [‡]	MAX	MIN	TYP [‡]	MAX	
Input voltage range (either input)		-0.7 to +1			-0.7 to +1			V
Sense voltage for 2-V output at pin 9	$V(\text{pin } 2) - V(\text{pin } 1) \geq 50\text{ mV}$, $T_A = 25^\circ\text{C}$	190	200	210	180	200	220	mV
Sense voltage	$T_A = \text{MIN to MAX}$		0.2			0.2		$\text{mV}/^\circ\text{C}$

[†]For conditions shown as MIN or MAX, use the appropriate value specified under recommended operating conditions.

[‡]All typical values except for temperature coefficients are at $T_A = 25^\circ\text{C}$.

§Standard deviation is a measure of the statistical distribution about the mean as derived from the formula $\sigma = \sqrt{\frac{\sum_{n=1}^N (X_n - \bar{X})^2}{N - 1}}$

TYPES SG1524, SG2524, SG3524

REGULATING PULSE WIDTH MODULATORS

electrical characteristics over recommended operating free-air temperature range, $V_{CC} = 20\text{ V}$, $f = 20\text{ kHz}$ (unless otherwise noted)

output section

PARAMETER	TEST CONDITIONS	MIN	TYP [‡]	MAX	UNIT
Collector-emitter breakdown voltage		40			V
Collector off-state current	$V_{CE} = 40\text{ V}$		0.01	50	μA
Collector-emitter saturation voltage	$I_C = 50\text{ mA}$		1	2	V
Emitter output voltage	$V_C = 20\text{ V}$, $I_E = -250\text{ }\mu\text{A}$	17	18		V
Turn-off voltage rise time	$R_C = 2\text{ k}\Omega$		0.2		μs
Turn-on voltage fall time	$R_C = 2\text{ k}\Omega$		0.1		μs

total device

PARAMETER	TEST CONDITIONS	MIN	TYP [‡]	MAX	UNIT
Standby current	$V_{CC} = 40\text{ V}$, Pin 2 at 2 V, Pins 1,4,7,8,9,11,14 grounded, All other inputs and outputs open		8	10	mA

[‡]All typical values except for temperature coefficients are at $T_A = 25^\circ\text{C}$.

PARAMETER MEASUREMENT INFORMATION

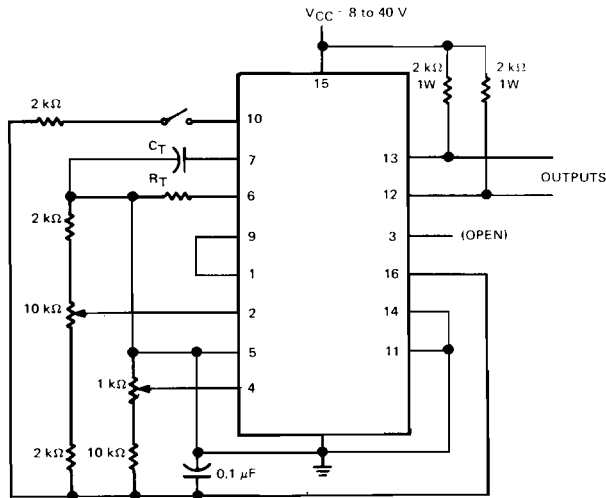

FIGURE 1—GENERAL TEST CIRCUIT

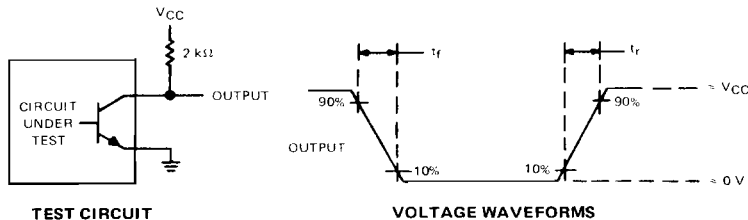

FIGURE 2—SWITCHING TIMES

TYPES SG1524, SG2524, SG3524 REGULATING PULSE WIDTH MODULATORS

TYPICAL CHARACTERISTICS

OPEN-LOOP VOLTAGE AMPLIFICATION
OF ERROR AMPLIFIER
vs
FREQUENCY

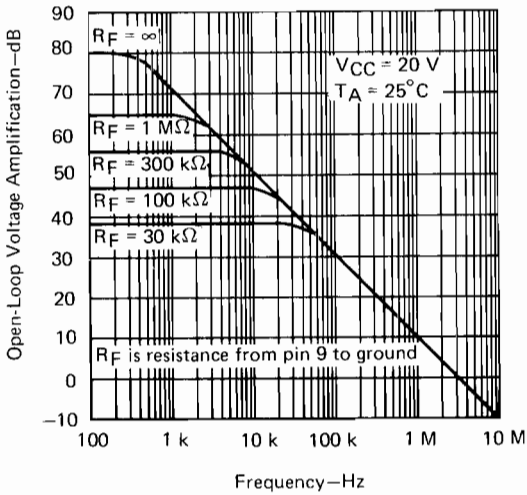

FIGURE 3

OSCILLATOR FREQUENCY
vs
TIMING RESISTANCE

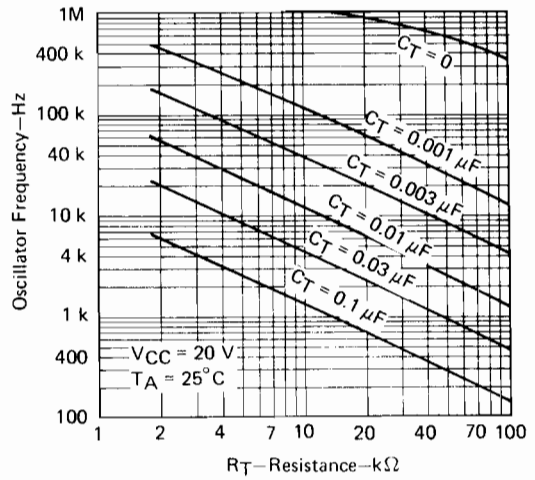

FIGURE 4

OUTPUT DEAD TIME
vs
TIMING CAPACITANCE VALUE

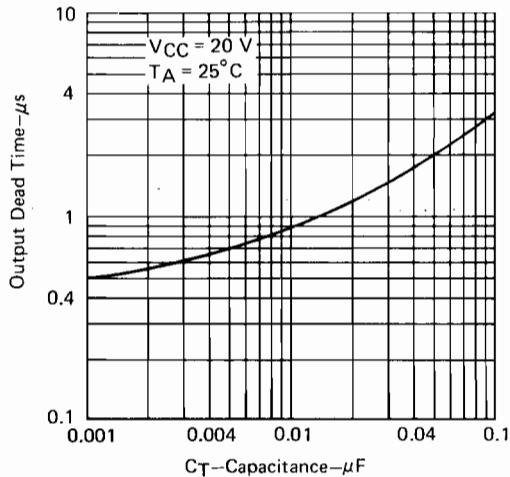

FIGURE 5

TYPES SG1524, SG2524, SG3524

REGULATING PULSE WIDTH MODULATORS

PRINCIPLES OF OPERATION

The SG1524[†] is a fixed-frequency pulse-width-modulation voltage-regulator control circuit. The regulator operates at a fixed frequency that is programmed by one timing resistor R_T and one timing capacitor C_T . R_T establishes a constant charging current for C_T . This results in a linear voltage ramp at C_T , which is fed to the comparator providing linear control of the output pulse width by the error amplifier. The SG1524 contains an on-board 5-volt regulator that serves as a reference as well as supplying the SG1524's internal regulator control circuitry. The internal reference voltage is divided externally by a resistor ladder network to provide a reference within the common-mode range of the error amplifier as shown in Figure 6, or an external reference may be used. The output is sensed by a second resistor divider network and the error signal is amplified. This voltage is then compared to the linear voltage ramp at C_T . The resulting modulated pulse out of the high-gain comparator is then steered to the appropriate output pass transistor (Q1 or Q2) by the pulse-steering flip-flop, which is synchronously toggled by the oscillator output. The oscillator output pulse also serves as a blanking pulse to assure both outputs are never on simultaneously during the transition times. The width of the blanking pulse is controlled by the value of C_T . The outputs may be applied in a push-pull configuration in which their frequency is half that of the base oscillator, or paralleled for single-ended applications in which the frequency is equal to that of the oscillator. The output of the error amplifier shares a common input to the comparator with the current-limiting and shut-down circuitry and can be overridden by signals from either of these inputs. This common point is also available externally and may be employed to control the gain of, or to compensate, the error amplifier, or to provide additional control to the regulator.

TYPICAL APPLICATION DATA

oscillator

The oscillator controls the frequency of the SG1524 and is programmed by R_T and C_T as shown in Figure 4.

$$f \approx \frac{1.15}{R_T C_T}$$

where R_T is in kilohms

C_T is in microfarads

f is in kilohertz

Practical values of C_T fall between 0.001 and 0.1 microfarad. Practical values of R_T fall between 1.8 and 100 kilohms. This results in a frequency range typically from 140 hertz to 500 kilohertz.

blanking

The output pulse of the oscillator is used as a blanking pulse at the output. This pulse width is controlled by the value of C_T as shown in Figure 5. If small values of C_T are required, the oscillator output pulse width may still be maintained by applying a shunt capacitance from pin 3 to ground.

synchronous operation

When an external clock is desired, a clock pulse of approximately 3 volts can be applied directly to the oscillator output terminal. The impedance to ground at this point is approximately 2 kilohms. In this configuration R_T C_T must be selected for a clock period slightly greater than that of the external clock.

If two or more SG1524 regulators are to be operated synchronously, all oscillator output terminals should be tied together. The oscillator programmed for the minimum clock period will be the master from which all the other SG1524's operate. In this application, the C_T R_T values of the slaved regulators must be set for a period approximately 10% longer than that of the master regulator. In addition, C_T (master) = 2 C_T (slave) to ensure that the master output pulse, which occurs first, has a wider pulse width and will subsequently reset the slave regulators.

[†]Throughout these discussions, references to SG1524 apply also to SG2524 and SG3524.

TYPES SG1524, SG2524, SG3524 REGULATING PULSE WIDTH MODULATORS

TYPICAL APPLICATION DATA

voltage reference

The 5-volt internal reference may be employed by use of an external resistor divider network to establish a reference within the error amplifiers common-mode voltage range (1.8 to 3.4 volts) as shown in Figure 6, or an external reference may be applied directly to the error amplifier. For operation from a fixed 5-volt supply, the internal reference may be bypassed by applying the input voltage to both the V_{CC} and V_{REF} terminals. In this configuration, however, the input voltage is limited to a maximum of 6 volts.

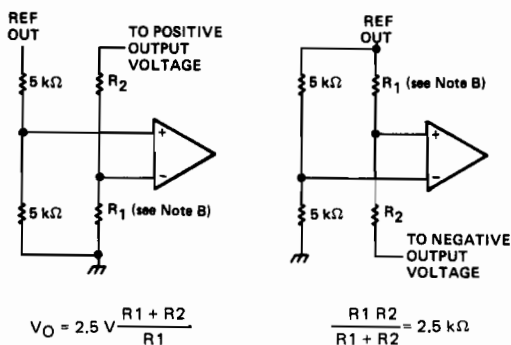

FIGURE 6—ERROR AMPLIFIER BIAS CIRCUITS

error amplifier

The error amplifier is a differential-input transconductance amplifier. The output is available for dc gain control or ac phase compensation. The compensation node (pin 9) is a high-impedance node ($R_L = 5$ megohms). The gain of the amplifier is $A_V = (0.002 \Omega^{-1}) R_L$ and can easily be reduced from a nominal 10,000 by an external shunt resistance from pin 9 to ground. Refer to Figure 3 for data.

compensation

Pin 9, as discussed above, is made available for compensation. Since most output filters will introduce one or more additional poles at frequencies below 200 hertz, which is the pole of the uncompensated amplifier, introduction of a zero to cancel one of the output filter poles is desirable. This can best be accomplished with a series RC circuit from pin 9 to ground in the range of 50 kilohms and 0.001-microfarads. Other frequencies can be canceled by use of the formula $f \approx 1/RC$.

shut down circuitry

Pin 9 can also be employed to introduce external control of the SG1524. Any circuit that can sink 200 microamperes can pull the compensation terminal to ground and thus disable the SG1524.

In addition to constant-current limiting, pins 4 and 5 may also be used in transformer-coupled circuits to sense primary current and shorten an output pulse should transformer saturation occur. Pin 5 may also be grounded to convert pin 4 into an additional shutdown terminal.

TYPES SG1524, SG2524, SG3524 REGULATING PULSE WIDTH MODULATORS

TYPICAL APPLICATION DATA

current limiting

A current-limiting sense amplifier is provided in the SG1524. The current-limiting sense amplifier exhibits a threshold of 200 millivolts and must be applied in the ground line since the voltage range of the inputs is limited to +1 volt to -0.7 volt. Caution should be taken to ensure the -0.7-volt limit is not exceeded by either input, otherwise damage to the device may result.

Fold-back current limiting can be provided with the network shown in Figure 7. The current-limit schematic is shown in Figure 8.

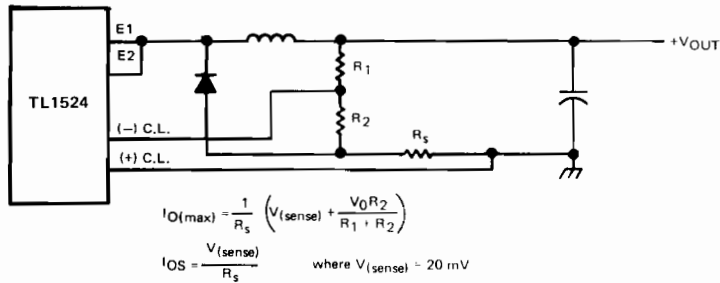

FIGURE 7—FOLDBACK CURRENT LIMITING FOR SHORTED OUTPUT CONDITIONS

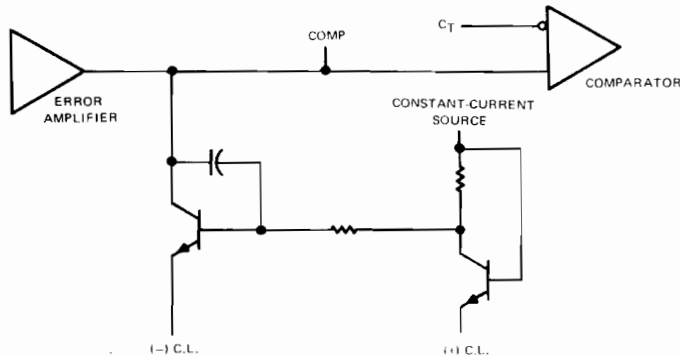

FIGURE 8—CURRENT-LIMIT SCHEMATIC

output circuitry

The SG1524 contains two identical n-p-n transistors the collectors and emitters of which are uncommitted. Each transistor has antisaturation circuitry that limits the current through that transistor to a maximum of 100 milliamperes for fast response.

TYPES SG1524, SG2524, SG3524 REGULATING PULSE WIDTH MODULATORS

TYPICAL APPLICATION DATA

general

There are a wide variety of output configurations possible when considering the application of the SG1524 as a voltage regulator control circuit. They can be segregated into three basic categories:

1. Capacitor-diode-coupled voltage multipliers
2. Inductor-capacitor-implemented single-ended circuits
3. Transformer-coupled circuits

Examples of these categories are shown in Figures 9, 10 and 11, respectively. Detailed diagrams of specific applications are shown in Figures 12 through 15.

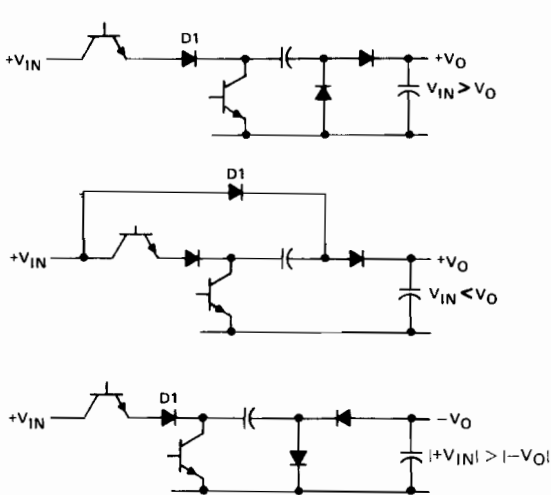

FIGURE 9—CAPACITOR-DIODE-COUPLED VOLTAGE-MULTIPLIER OUTPUT STAGES

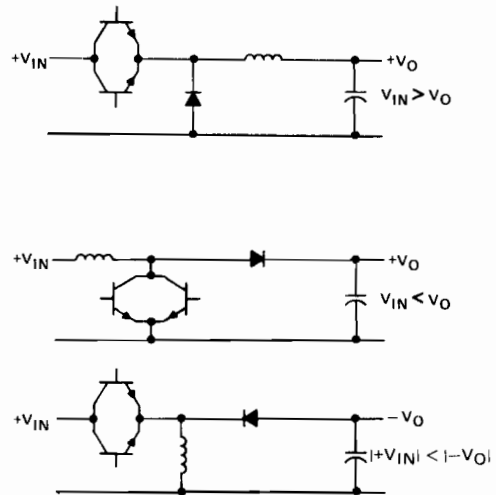
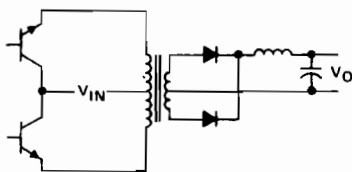
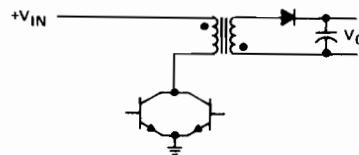

FIGURE 10—SINGLE-ENDED INDUCTOR CIRCUIT



PUSH PULL



FLYBACK

FIGURE 11—TRANSFORMER-COUPLED OUTPUTS

TYPES SG1524, SG2524, SG3524 REGULATING PULSE WIDTH MODULATORS

TYPICAL APPLICATION DATA

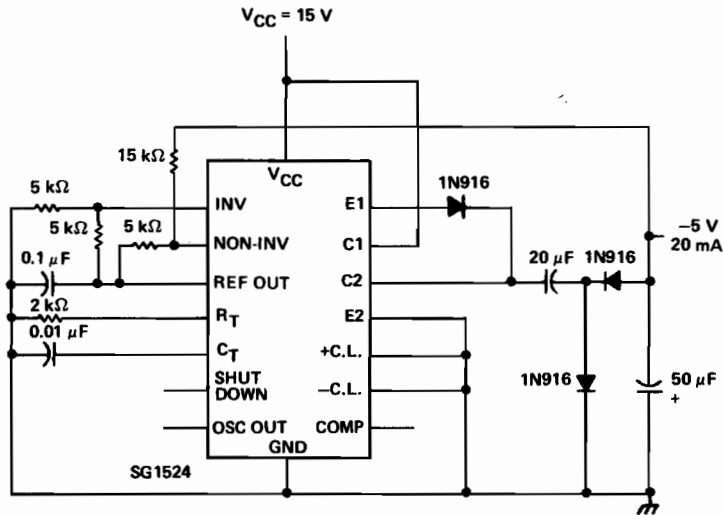

FIGURE 12—CAPACITOR-DIODE OUTPUT CIRCUIT

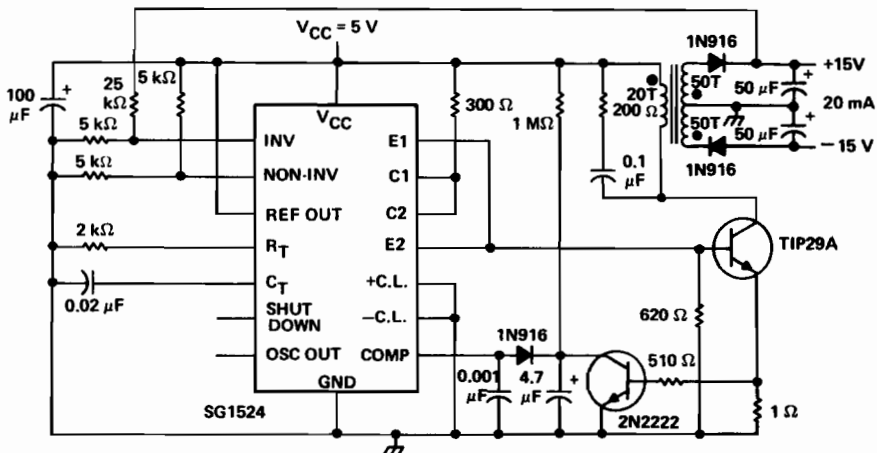

FIGURE 13 — FLYBACK CONVERTER CIRCUIT

TYPES SG1524, SG2524, SG3524 REGULATING PULSE WIDTH MODULATORS

TYPICAL APPLICATION DATA

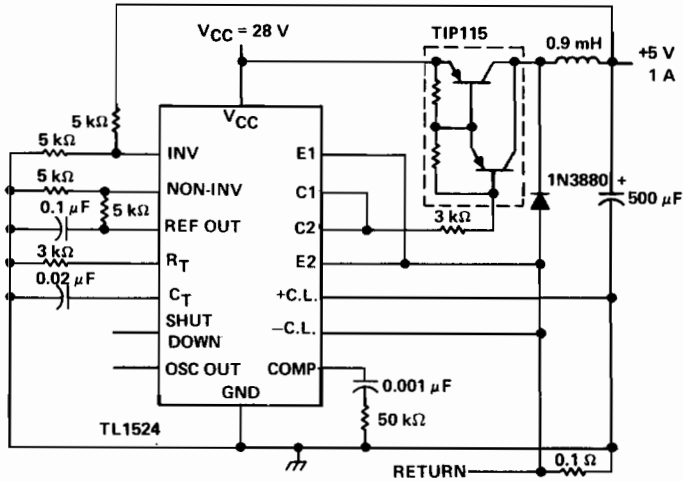

FIGURE 14—SINGLE-ENDED LC CIRCUIT

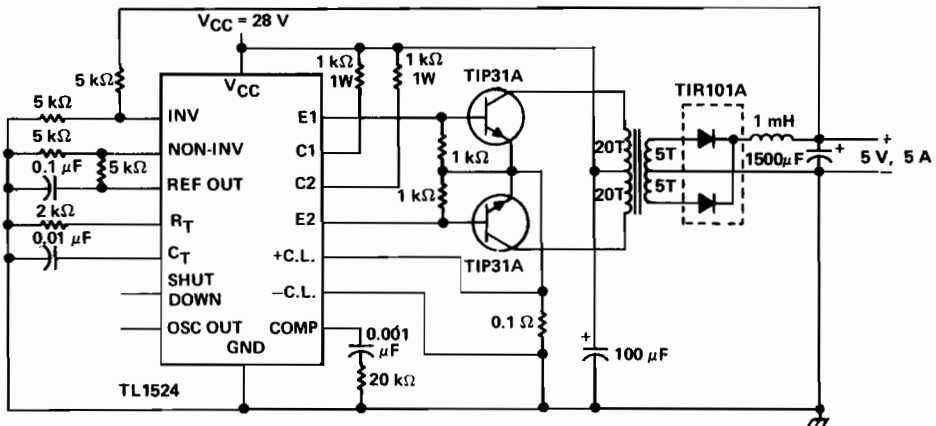

FIGURE 15—PUSH-FULL TRANSFORMER-COUPLED CIRCUIT

TYPES SG1524, SG2524, SG3524 REGULATING PULSE WIDTH MODULATORS

THERMAL INFORMATION

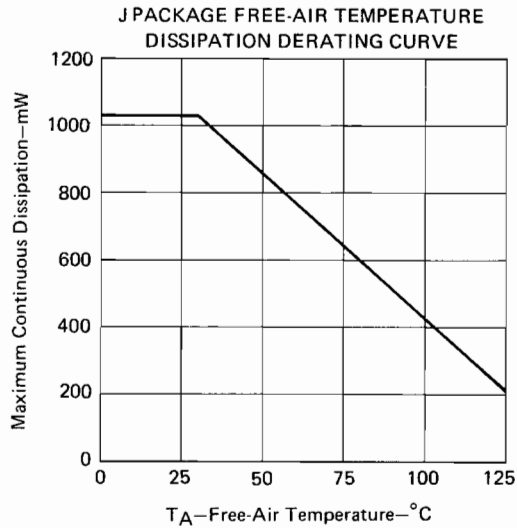

FIGURE 16

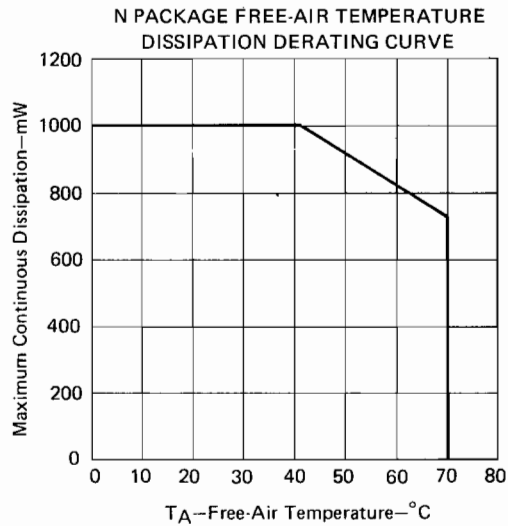

FIGURE 17

- Temperature Compensated
- Programmable Output Voltage
- Low Output Resistance
- Low Output Noise
- Sink Capability to 100 mA

description

The TL430 is a three-terminal adjustable shunt regulator featuring excellent temperature stability, wide operating current range, and low output noise. The output voltage may be set by two external resistors to any desired value between 3 volts and 30 volts. The TL430 can replace zener diodes in many applications providing improved performance.

The TL430I is characterized for operation from -25°C to 85°C , and the TL430C is characterized for operation from 0°C to 70°C .

functional block diagram

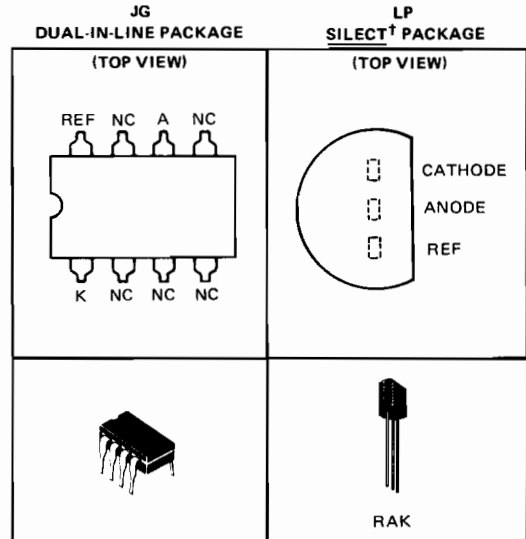
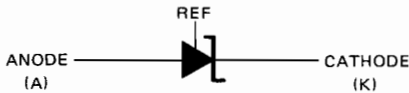

NC—No internal connection

absolute maximum ratings over operating free-air temperature range (unless otherwise noted)

Regulator voltage (see Note 1)	30 V
Continuous regulator current	150 mA
Continuous dissipation at (or below) 25°C free-air temperature (see Note 2): JG Package	825 mW
LP package	775 mW
Operating free-air temperature range: TL430I	-40°C to 85°C
TL430C	0°C to 70°C
Storage temperature range	-65°C to 150°C
Lead temperature 1/16 inch from case for 60 seconds: JG package	300°C
Lead temperature 1/16 inch from case for 10 seconds: LP package	260°C

recommended operating conditions

	MIN	MAX	UNIT
Regulator voltage, V_Z	V_{ref}	30	V
Regulator current, I_Z	2	100	mA

- NOTES: 1. All voltage values are with respect to the anode terminal.
2. For operation above 25°C free-air temperature, refer to Dissipation Derating Curves, Figures 5 and 6, page 127.

† Trademark Registered U.S. Patent Office

TYPES TL430I, TL430C ADJUSTABLE SHUNT REGULATORS

electrical characteristics at 25°C free-air temperature (unless otherwise noted)

PARAMETER	TEST FIGURE	TEST CONDITIONS	TL430I			TL430C			UNIT
			MIN	TYP	MAX	MIN	TYP	MAX	
V_{ref} Reference input voltage	1	$V_Z = V_{ref}$, $I_Z = 10 \text{ mA}$	2.6	2.75	2.9	2.5	2.75	3	V
αV_{ref} Temperature coefficient of reference input voltage	1	$V_Z = V_{ref}$, $I_Z = 10 \text{ mA}$, $T_A = 0^\circ\text{C to } 70^\circ\text{C}$		+120	+200		+120		ppm/°C
I_{ref} Reference input current	2	$I_Z = 10 \text{ mA}$, $R_1 = 10 \text{ k}\Omega$, $R_2 = \infty$		3	10		3	10	μA
I_{ZK} Regulator current near lower knee of regulation range	1	$V_Z = V_{ref}$		0.5	2		0.5	2	mA
I_{ZM} Regulator current at maximum limit of regulation range	1	$V_Z = V_{ref}$		50			50		mA
	2	$V_Z = 5 \text{ V to } 30 \text{ V}$, See Note 3		100			100		
r_z Differential regulator resistance (see Note 4)	1	$V_Z = V_{ref}$, $\Delta I_Z = (52-2) \text{ mA}$		1.5	3		1.5	3	Ω
V_{nz} Noise voltage	2	$f = 0.1 \text{ Hz to } 10 \text{ Hz}$	$V_Z = 3 \text{ V}$		50		50		μV
			$V_Z = 12 \text{ V}$		200		200		
			$V_Z = 30 \text{ V}$		650		650		

NOTES 3. The average power dissipation, $V_Z \cdot I_Z \cdot \text{duty cycle}$, must not exceed the maximum continuous rating in any 10-ms interval.
4. The regulator resistance for $V_Z > V_{ref}$, r_z' , is given by:

$$r_z' = r_z \left(1 + \frac{R_1}{R_2} \right)$$

PARAMETER MEASUREMENT INFORMATION

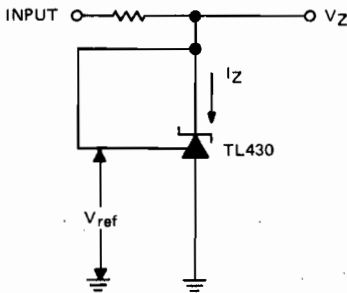
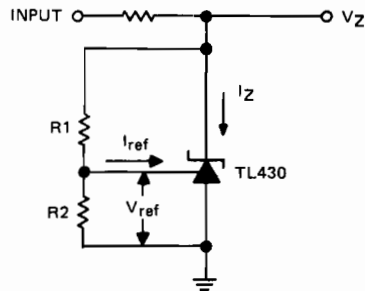

FIGURE 1—TEST CIRCUIT FOR $V_Z = V_{ref}$



$$V_Z = V_{ref} \left(1 + \frac{R_1}{R_2} \right) + I_{ref} \cdot R_1$$

FIGURE 2—TEST CIRCUIT FOR $V_Z > V_{ref}$

TYPES TL430I, TL430C ADJUSTABLE SHUNT REGULATORS

TYPICAL CHARACTERISTICS

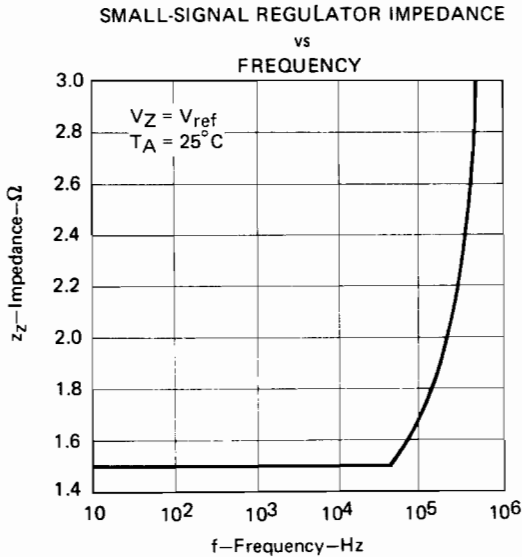

FIGURE 3

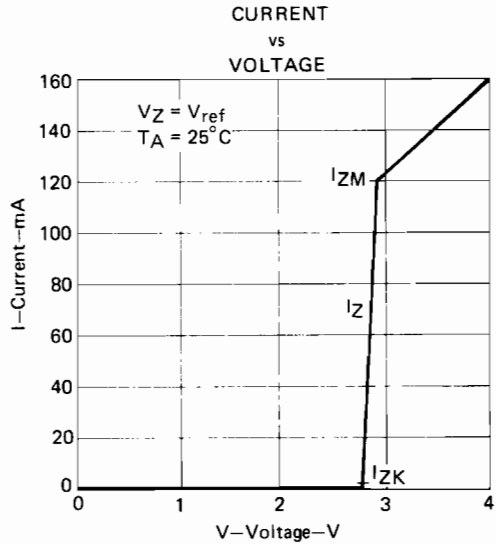

FIGURE 4

THERMAL INFORMATION

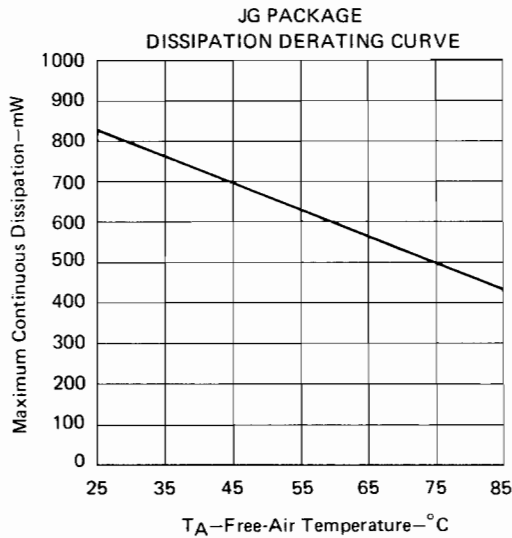

FIGURE 5

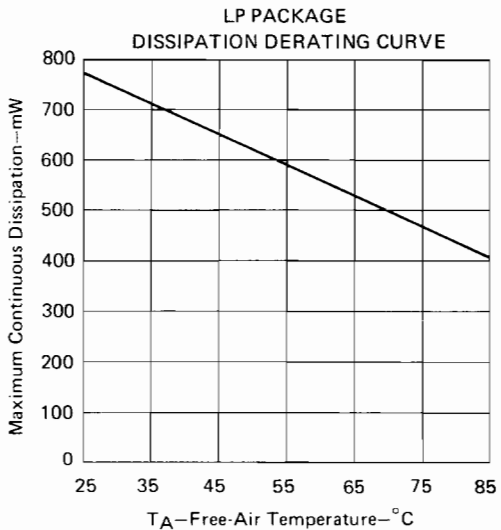

FIGURE 6

TYPES TL430I, TL430C ADJUSTABLE SHUNT REGULATORS

TYPICAL APPLICATION DATA

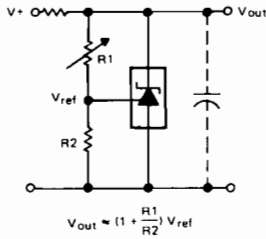

FIGURE 8—SHUNT REGULATOR

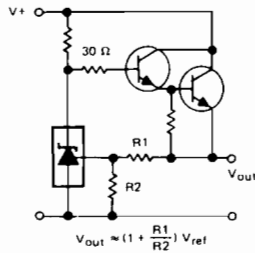

FIGURE 9—SERIES REGULATOR

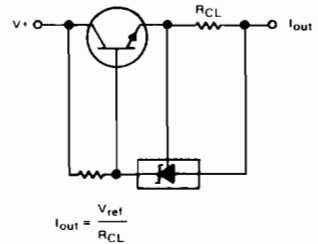

FIGURE 10—CURRENT LIMITER

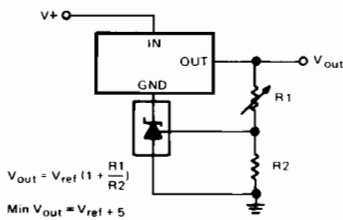

FIGURE 11—OUTPUT CONTROL OF A
THREE-TERMINAL
FIXED REGULATOR

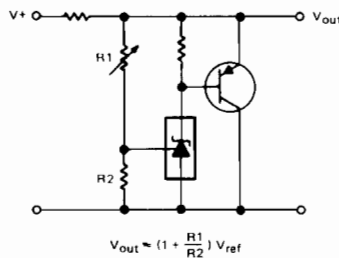

FIGURE 12—HIGHER-CURRENT
APPLICATIONS

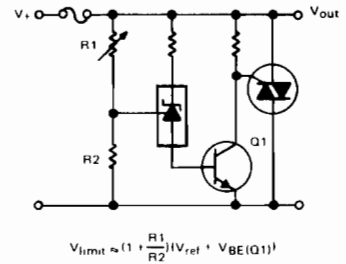

FIGURE 13—CROW BAR

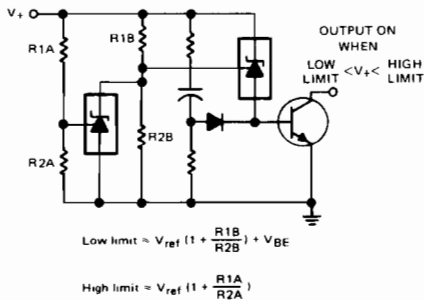

FIGURE 14—OVER-VOLTAGE/UNDER-VOLTAGE
PROTECTION CIRCUIT

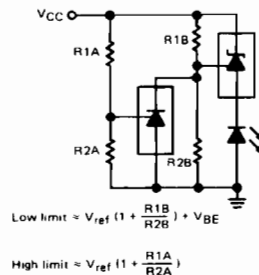

FIGURE 15— V_{CC} MONITOR

**FUTURE PRODUCT
TO BE ANNOUNCED**

**TYPES TL431M, TL431I, TL431C
ADJUSTABLE PRECISION SHUNT REGULATORS**

SEPTEMBER 1977

- Temperature-Compensated for Operation Over the Full Rated Operating Temperature Range
- Programmable Output Voltage
- Low Output Resistance
- Low Output Noise
- Sink Current Capability to 100 mA

description

The TL431 is a three-terminal adjustable regulator with guaranteed thermal stability over applicable temperature ranges. The output voltage may be set to any value between 3 V and 30 V by two resistors. Active output circuitry provides a very sharp turn-on characteristic even at low voltages, making these devices excellent replacements for zener diodes in many applications.

The TL431M is characterized for operation from -55°C to 125°C , the TL431I from -40°C to 85°C , and the TL431C from 0°C to 70°C .

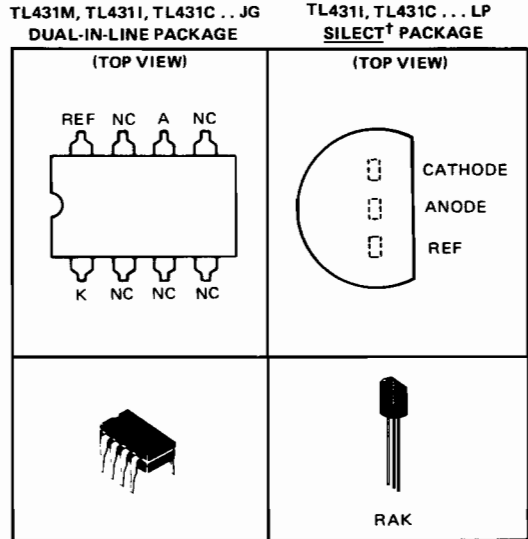

NC—No internal connection

functional block diagram

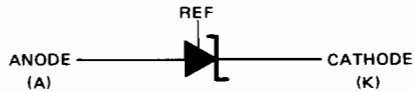

absolute maximum ratings over operating free-air temperature range (unless otherwise noted)

Regulator voltage (see Note 1)	40 V
Continuous regulator current	100 mA
Continuous dissipation at (or below) 25°C free-air temperature (see Note 2): JG package	825 mW
LP package	775 mW
Operating free-air temperature range: TL431C	0°C to 70°C
TL431I	-40°C to 85°C
TL431M	-55°C to 125°C
Storage temperature range	-65°C to 150°C
Lead temperature 1/16-inch from case for 60 seconds: JG package	300°C
Lead temperature 1/16-inch from case for 10 seconds: LP package	260°C

recommended operating conditions

	MIN	MAX	UNIT
Regulator voltage, V_Z	V_{ref}	35	V
Regulator current, I_Z	2	100	mA

NOTES: 1. All voltage values are with respect to the anode terminal.
2. For operation above 25°C free-air temperature, refer to Dissipation Derating Curves, Figure 6 and Figure 7, page 131.

[†]Trademark Registered U.S. Patent Office

DESIGN GOAL

Copyright © 1977 by Texas Instruments Incorporated

This document provides tentative information on a product in the developmental stage. Texas Instruments reserves the right to change or discontinue this product without notice.

TEXAS INSTRUMENTS
INCORPORATED
POST OFFICE BOX 5012 • DALLAS, TEXAS 75222

TYPES TL431M, TL431I, TL431C

ADJUSTABLE PRECISION SHUNT REGULATORS

electrical characteristics at 25°C free-air temperature (unless otherwise noted)

PARAMETER	TEST FIGURE	TEST CONDITIONS	TL431M, TL431I			TL431C			UNIT
			MIN	TYP	MAX	MIN	TYP	MAX	
V_{ref} Reference input voltage	1	$V_Z = V_{ref}$, $I_Z = 10 \text{ mA}$	2.6	2.75	2.9	2.7	2.75	2.8	V
αV_{ref} Temperature coefficient of reference input voltage	1	$V_Z = V_{ref}$, $I_Z = 10 \text{ mA}$, $T_A = \text{full range}^\dagger$		+30	+100		+10	+50	ppm/°C
I_{ref} Reference input current	2	$I_Z = 10 \text{ mA}$, $R_1 = 10 \text{ k}\Omega$, $R_2 = \infty$, $T_A = \text{full range}^\dagger$		10	50		3	10	μA
I_{ZK} Regulator current near lower knee of regulation range	1	$V_Z = V_{ref}$		0.5	2		0.5	2	mA
I_{ZM} Regulator current at maximum limit of regulator range	1	$V_Z = V_{ref}$, See Note 3		100			100		mA
r_z Differential regulator resistance (see Note 4)	1	$V_Z = V_{ref}$, $\Delta I_Z = 52 \text{ mA to } 2 \text{ mA}$		1.5	3		1.5	3	Ω
$\frac{V_{nz}}{V_Z}$ Ratio of noise voltage to operating voltage		$V_Z = 3 \text{ to } 30 \text{ V}$, $I_Z = 10 \text{ mA}$, $f = 0.1 \text{ Hz to } 10 \text{ Hz}$		-95			-95		dB
t_{on}	3			100			100		μs
t_{off}	3			100			100		μs

† Full range is -55°C to 125°C for the TL431M, -40°C to 85°C for the TL431I, and 0°C to 70°C for the TL431C.

NOTES: 3. The average power dissipation, $V_Z \cdot I_Z \cdot \text{duty cycle}$, must not exceed the maximum continuous rating for any 10-ms interval.

4. The regulator resistance for $V_Z > V_{ref}$, r_z' , is given by:

$$r_z' = r_z \left(1 + \frac{R_1}{R_2} \right)$$

PARAMETER MEASUREMENT INFORMATION

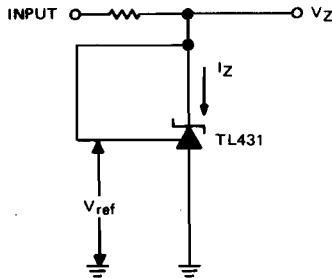

FIGURE 1—TEST CIRCUIT FOR $V_Z = V_{ref}$

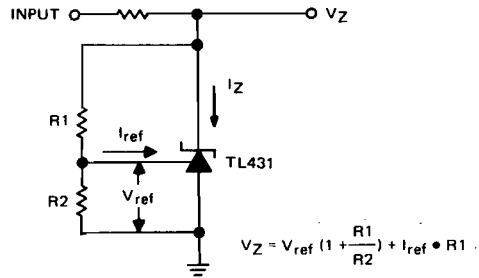

FIGURE 2—TEST CIRCUIT FOR $V_Z > V_{ref}$

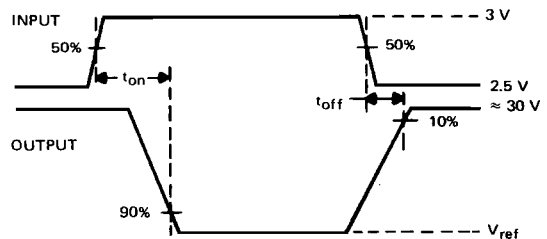
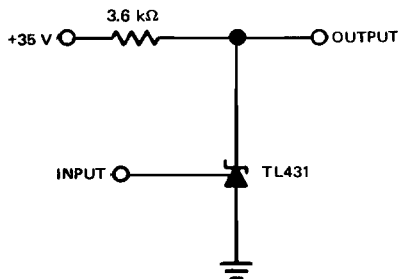
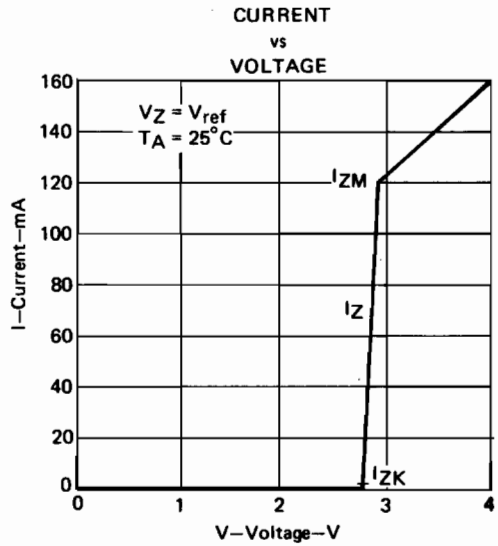
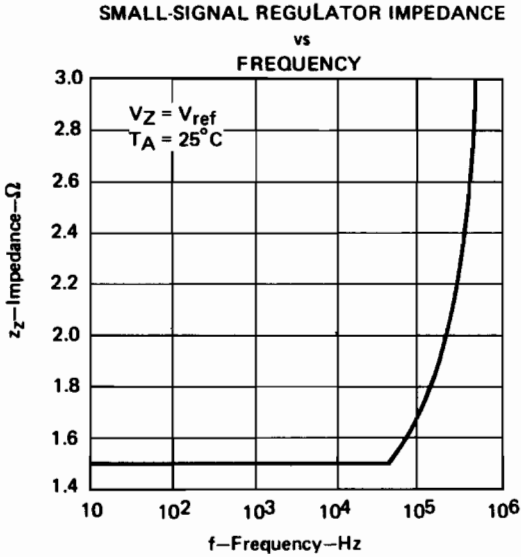

FIGURE 3—TEST CIRCUIT FOR t_{on} AND t_{off}

TYPES TL431M, TL431I, TL431C ADJUSTABLE PRECISION SHUNT REGULATORS

TYPICAL CHARACTERISTICS



THERMAL INFORMATION

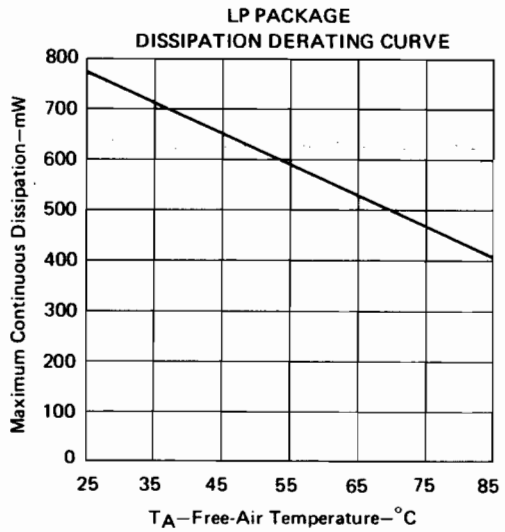
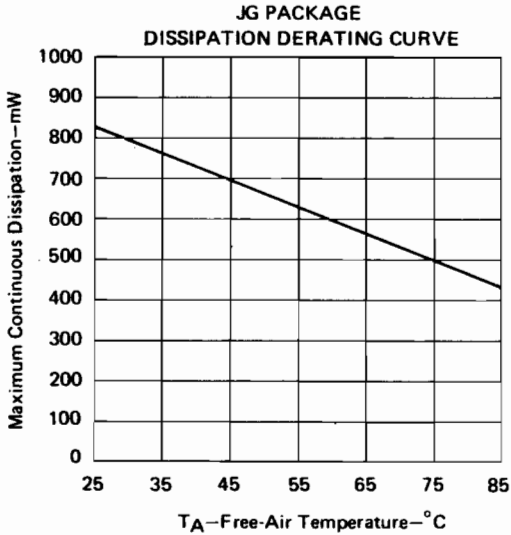

TYPES TL431M, TL431I, TL431C ADJUSTABLE PRECISION SHUNT REGULATORS

TYPICAL APPLICATION DATA

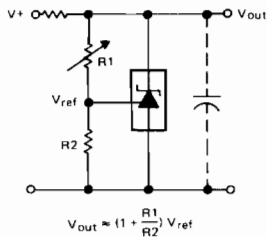

FIGURE 8—SHUNT REGULATOR

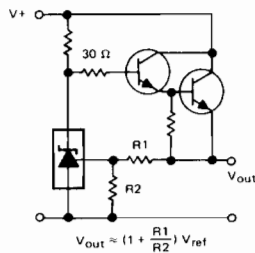

FIGURE 9—SERIES REGULATOR

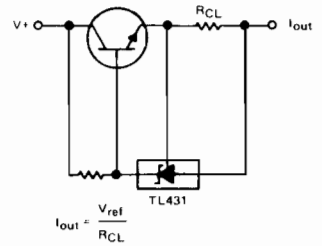

FIGURE 10—CURRENT LIMITER

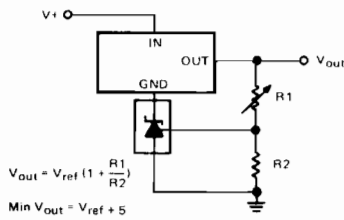

FIGURE 11—OUTPUT CONTROL OF A
THREE-TERMINAL
FIXED REGULATOR

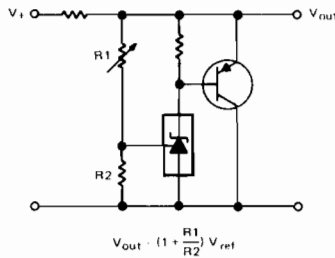

FIGURE 12—HIGHER-CURRENT
APPLICATIONS

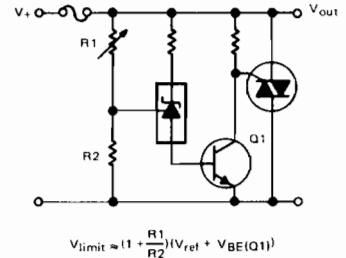

FIGURE 13—CROW BAR

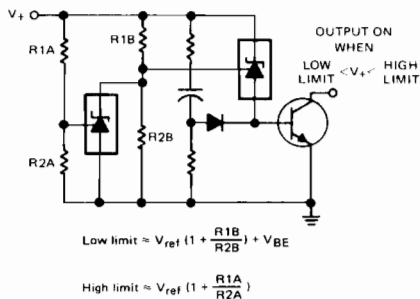

FIGURE 14—OVER-VOLTAGE/UNDER-VOLTAGE
PROTECTION CIRCUIT

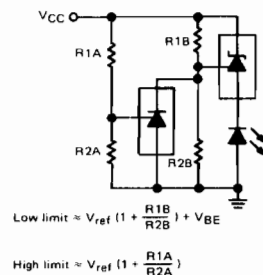

FIGURE 15—V_{CC} MONITOR

FUTURE PRODUCT TO BE ANNOUNCED

TYPES TL432M, TL432I, TL432C TIMER/REGULATOR/COMPARATOR BUILDING BLOCKS

SEPTEMBER 1977

- Temperature-Compensated 2.75-V Reference
- Uncommitted Output Transistor
- 100-mA Drive Capability
- High Comparator Input Impedance
- Wide Operating Voltage Range

description

The TL432 is a versatile group of building blocks developed for a broad range of comparator functions. It contains a high-gain comparator, a temperature-compensated 2.75-volt reference, and a booster transistor capable of sinking or sourcing 100 milliamperes. The uncommitted inputs and outputs of the comparator and booster transistor provide design flexibility to include series regulators, shunt regulators, detectors, timers, and current regulators. This monolithic integrated circuit can be used over a wide range of operating voltage.

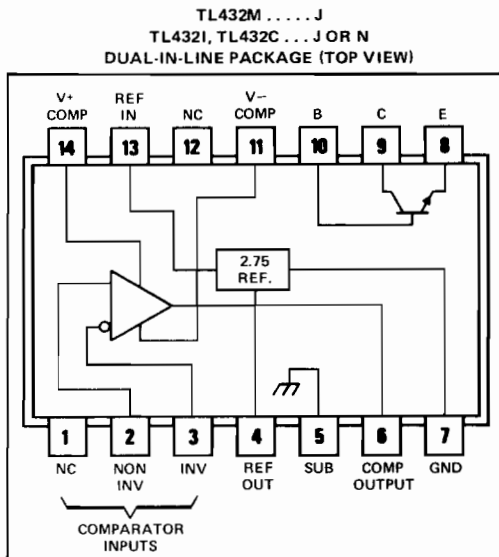

The TL432M will be characterized for operation over the full military temperature range of -55°C to 125°C . The TL432I will be characterized for operation from -40°C to 85°C , and the TL432C from 0°C to 70°C .

typical applications

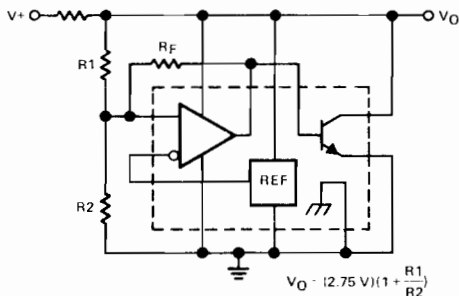

FIGURE 1—SHUNT REGULATOR

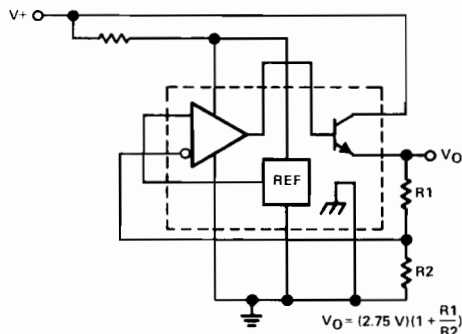

FIGURE 2—SERIES REGULATOR

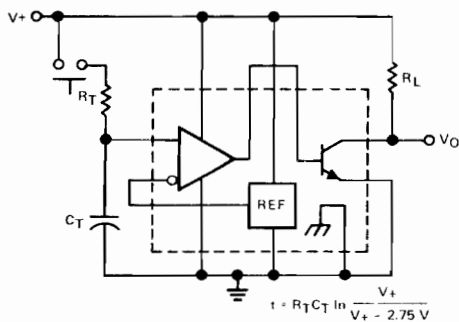

FIGURE 3—BASIC TIMER

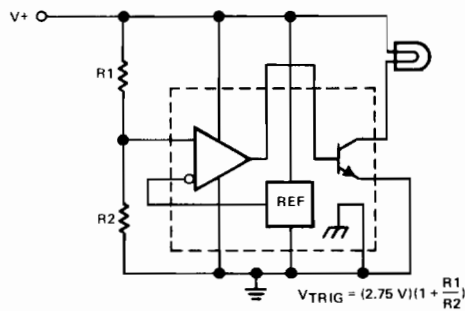

FIGURE 4—OVER-VOLTAGE DETECTOR

DESIGN GOAL

Copyright © 1977 by Texas Instruments Incorporated

This document provides tentative information on a product in the developmental stage. Texas Instruments reserves the right to change or discontinue this product without notice.

TEXAS INSTRUMENTS
INCORPORATED
POST OFFICE BOX 5012 • DALLAS, TEXAS 75222

**FUTURE PRODUCT
TO BE ANNOUNCED**

**TYPES TL494M, TL494I, TL494C
PULSE-WIDTH-MODULATION CONTROL CIRCUIT**

SEPTEMBER 1977

- Complete PWM Power Control Circuitry
- Uncommitted Outputs for Single-Ended or Push-Pull Operation
- Internal Circuitry Prohibits Double Pulse at Either Output
- Variable Dead-Time Control . . . 45% to 0% at Each Output
- Oscillator Capable of Stand-Alone or Driven Operation

TL494M . . . J
TL494I, TL494C . . . J OR N
DUAL-IN-LINE PACKAGE
(TOP VIEW)

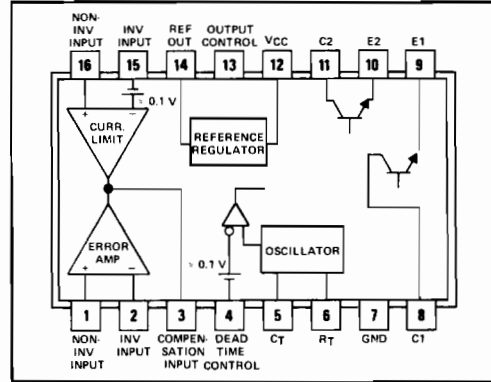

description

The TL494 incorporates on a monolithic chip all the functions required for pulse-width-modulation control circuits. Designed primarily for power supply control, the TL494 has an on-chip 5-volt regulator, error amplifier, current-limit amplifier, adjustable oscillator, dead time control comparator, pulse-steering flip-flop, and output control circuitry. The uncommitted output transistors may be operated common-collector or common-emitter. Internal circuitry provides output control for either complementary or tandem operation. The trigger for the pulse-steering flip-flop is derived from the pulse-width-modulation circuit to prevent double-pulsing of either output. Both the error amplifier and the current-limit amplifier have a common-mode input voltage range from -0.2 volt to $V_{CC} - 1.5$ volts. Fixed internal offsets provide a current-limit sense threshold of 0.1 volt for the current-limit amplifier and a 45% maximum duty cycle for the dead time control comparator. The oscillator can be programmed by passive components or driven by a master oscillator. The versatility of the TL494 makes it suitable for a variety of PWM applications including switching regulators (of either polarity) and dc-to-dc converters (with or without transformer-coupled outputs).

The TL494M will be characterized for operation over the full military temperature range of -55°C to 125°C . The TL494I will be characterized for operation from -25°C to 85°C , and the TL494C will be characterized for operation from 0°C to 70°C .

functional block diagram

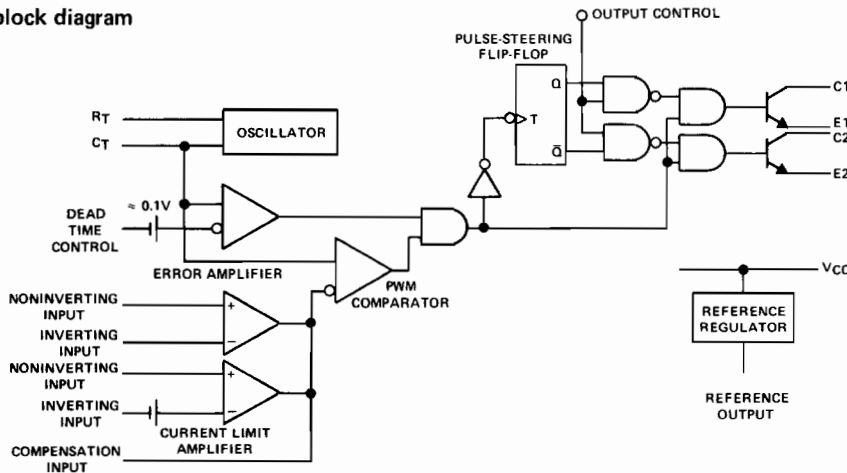

Copyright © 1977 by Texas Instruments Incorporated

DESIGN GOAL

This document provides tentative information on a product in the developmental stage. Texas Instruments reserves the right to change or discontinue this product without notice.

TEXAS INSTRUMENTS
INCORPORATED
POST OFFICE BOX 5012 • DALLAS, TEXAS 75222

TYPES TL494M, TL494I, TL494C

PULSE-WIDTH-MODULATION CONTROL CIRCUIT

recommended operating conditions

	MIN	MAX	UNIT
Supply voltage, V_{CC}	7	40	V
Collector output voltage		40	V
Collector output current (each transistor)		200	mA

electrical characteristics

	MIN	TYP	MAX	UNIT
Amplifier common-mode input voltage range	-0.2 to $V_{CC} - 2$			V
Input bias current (each amplifier)			500	nA
Current-limit sense threshold		0.1		V
Collector-emitter saturation voltage (at $I_C = 200$ mA)		1.2		V
Range of adjustment of maximum duty cycle (each output)	0 to 45			%
Frequency range	0.001 to 200			kHz
Standard deviation of frequency		2		%
Reference output voltage	4.75		5.25	V

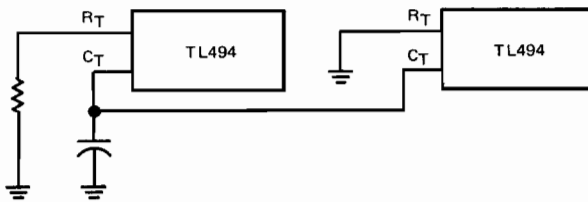

FIGURE 1—MASTER-SLAVE OSCILLATOR CONNECTION

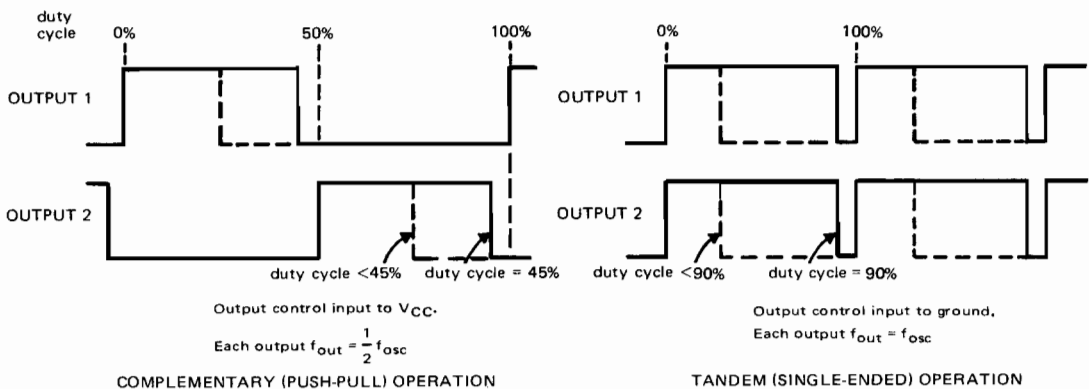

FIGURE 2—OUTPUT DUTY CYCLE AND PHASE RELATIONSHIPS

LINEAR INTEGRATED CIRCUITS

TYPES TL497AM, TL497AI, TL497AC SWITCHING VOLTAGE REGULATORS

BULLETIN NO. DL-S 12422, JUNE 1976—REVISED SEPTEMBER 1977

- All Monolithic
- High Efficiency . . . 60% or Greater
- Output Current . . . 500 mA
- Input Current Limit Protection
- TTL Compatible Inhibit
- Adjustable Output Voltage
- Input Regulation . . . 0.2% Typ
- Output Regulation . . . 0.4% Typ
- Soft Start-up Capability

description

The TL497A incorporates on a single monolithic chip all the active functions required in the construction of a switching voltage regulator. It can also be used as the control element to drive external components for high-power-output applications. The TL497A was designed for ease of use in step-up, step-down, or voltage inversion applications requiring high efficiency.

A block diagram of the TL497A is shown in the above pinout. The TL497A is a fixed-on-time variable-frequency switching voltage regulator control circuit. The on time is programmed by a single external capacitor connected between the frequency control pin and ground. This capacitor, C_T , is charged by an internal constant-current generator to a predetermined threshold. The charging current and the threshold vary proportionally with V_{CC} , thus the on time remains constant over the specified range of input voltage (5 to 12 volts). Typical on times for various values of C_T are as follows.

TIMING CAPACITOR, C_T (pF)	100	150	200	250	350	400	500	750	1000	1500	2000
ON-TIME (μ s)	11	15	19	22	26	32	44	56	80	120	180

The output voltage is programmed by an external resistor ladder network (R_1 and R_2 in Figures 1, 2, and 3) that attenuates the desired output voltage to 1.2 volts. This feedback voltage is compared to the 1.2-volt reference by the high-gain comparator. When the output voltage decays below the programmed voltage, the comparator enables the oscillator circuit, which charges and discharges C_T as described above. The internal pass transistor is driven on during the charging of C_T . The internal transistor may be used directly for switching currents up to 500 milliamperes. Its collector and emitter are uncommitted and it is current driven to allow operation from the positive supply voltage or ground. An internal Schottky diode matched to the current characteristics of the internal transistor is also available for blocking or commutating purposes. The TL479A also has on-chip current-limit circuitry that senses the peak currents in the switching regulator and protects the inductor against saturation and the pass transistor against overstress. The current limit is adjustable and is programmed by a single sense resistor, R_{CL} , connected between pin 14 and pin 13. The current-limit circuitry is activated when 0.7 volt is developed across R_{CL} . External gating is provided by the inhibit input. When the inhibit input is high, the output is turned off.

Simplicity of design is a primary feature of the TL497A. With only six external components (three resistors, two capacitors, and one inductor), the TL497A will operate in numerous voltage conversion applications (step-up, step-down, invert) with as much as 85% of the source power delivered to the load. The TL497A replaces the TL497 in all applications.

The TL497AM is characterized for operation over the full military temperature range of -55°C to 125°C , the TL497AI is characterized for operation from -25°C to 85°C , and the TL497AC from 0°C to 70°C .

TL497AM . . . J
TL497AI, TL497AC . . . J OR N
DUAL-IN-LINE PACKAGE (TOP VIEW)

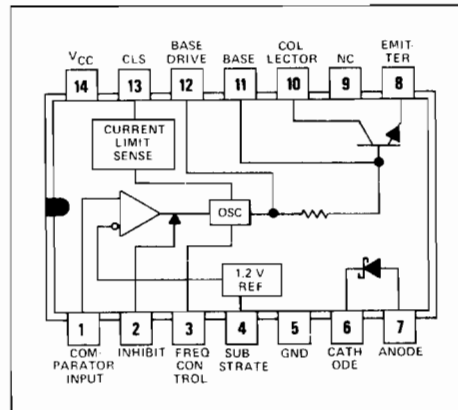

NC—No internal connection

TYPES TL497AM, TL497AI, TL497AC

SWITCHING VOLTAGE REGULATORS

absolute maximum ratings over operating free-air temperature range (unless otherwise noted)

Input voltage, V_{CC} (see Note 1)	15 V
Output voltage	35 V
Comparator input voltage	5 V
Inhibit input voltage	5 V
Diode reverse voltage	35 V
Power switch current	750 mA
Diode forward current	750 mA
Continuous total dissipation at (or below) 25°C free-air temperature (see Note 2)	1000 mW
Operating free-air temperature range: TL497AM	-55°C to 125°C
TL497AI	-25°C to 85°C
TL497AC	0°C to 70°C
Storage temperature range	-65°C to 150°C
Lead temperature 1/16 inch from case for 60 seconds: J package	300°C
Lead temperature 1/16 inch from case for 10 seconds: N package	260°C

- NOTES: 1. All voltage values except diode voltages are with respect to network ground terminal.
 2. For operation above 25°C free-air temperature, refer to Dissipation Derating Curves, Figure I and Figure III, page 90.

recommended operating conditions

	MIN	MAX	UNIT
Input voltage, V_I	4.5	12	V
Output voltage: step-up configuration (see Figure 2)	$V_I + 2$	30	V
step-down configuration (see Figure 3)	V_{ref}	$V_I - 1$	V
negative regulator (see Figure 4)	$-V_{ref}$	-25	V
Power switch current		500	mA
Diode forward current		500	mA

electrical characteristics at specified free-air temperature, $V_I = 6$ V (unless otherwise noted)

PARAMETER	TEST CONDITIONS†	TL497AM, TL497AI			TL497AC			UNIT	
		MIN	TYP‡	MAX	MIN	TYP‡	MAX		
High-level inhibit input voltage	25°C	3			2.5			V	
Low-level inhibit input voltage	25°C		0.6			0.8		V	
High-level inhibit input current	$V_I(t) = 5$ V	Full range	0.8	1.5		0.8	1.5	mA	
Low-level inhibit input current	$V_I(t) = 0$ V	Full range	5	20		5	10	μA	
Comparator reference voltage	$V_I = 4.5$ V to 6 V	Full range	1.14	1.20	1.26	1.08	1.20	1.32	V
Comparator input bias current	$V_I = 6$ V	Full range		40	100		40	100	μA
Switch on-state voltage	$V_I = 4.5$ V	$I_O = 100$ mA	25°C	0.13	0.2	0.13	0.2	V	
		$I_O = 500$ mA	Full range		1		0.85		
Switch off-state current	$V_I = 4.5$ V, $V_O = 30$ V	25°C		10	50		10	50	μA
		Full range			500		200		
Current-limit sense voltage	$V_{CC} = 6$ V	25°C	0.45		1	0.45		1	V
Diode forward voltage	$I_O = 10$ mA	Full range	0.75	0.95		0.75	0.85		
	$I_O = 100$ mA	Full range	0.9	1.1		0.9	1		
	$I_O = 500$ mA	Full range	1.33	1.75		1.33	1.55		
Diode reverse voltage	$I_O = 500$ μA	Full range	30					V	
	$I_O = 200$ μA	Full range			30				
On-state supply current	25°C		11	14		11	14	mA	
	Full range			16			15		
Off-state supply current	25°C		6	9		6	9	mA	
	Full range			11			10		

† Full range for TL497AM is -55°C to 125°C, for TL497AI is -25°C to 85°C, and for TL497AC is 0°C to 70°C.

‡ All typical values are at $T_A = 25$ °C.

TYPES TL497AM, TL497AI, TL497AC, SWITCHING VOLTAGE REGULATORS

TYPICAL APPLICATION DATA

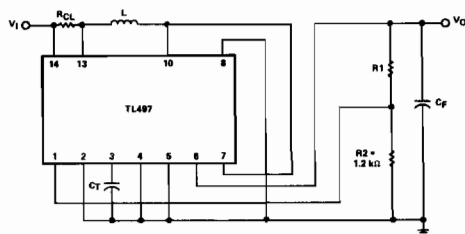

BASIC CONFIGURATION
($I_{PK} < 500 \text{ mA}$)

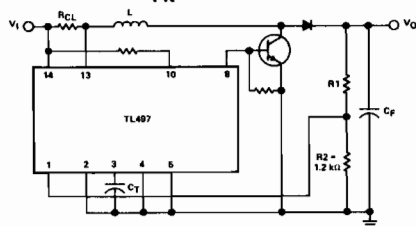

EXTENDED POWER CONFIGURATION
(USING EXTERNAL TRANSISTOR)

FIGURE 1—POSITIVE REGULATOR, STEP-UP CONFIGURATIONS

DESIGN EQUATIONS

- $I_{PK} = 2 I_{LOAD \text{ max}} \left[\frac{V_I - V_O}{V_I} + 1 \right]$

- $L (\mu\text{H}) = \frac{V_I}{I_{PK}} t_{on} (\mu\text{s})$

Choose L (50 to 500 μH), calculate t_{on} (25 to 150 μs)

- $C_T (\text{pF}) \approx 12 t_{on} (\mu\text{s})$

- $R_1 = (V_O - 1.2) \text{ k}\Omega$

- $R_{CL} = \frac{0.5 \text{ V}}{I_{PK}}$

- $C_F (\mu\text{F}) \approx t_{on} \left[\frac{V_I}{V_O} I_{PK} + I_{LOAD} \right] \frac{1}{V_{RIPPLE} (\text{PK})}$

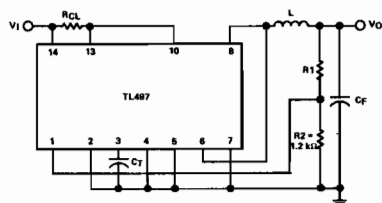

BASIC CONFIGURATION
($I_{PK} < 500 \text{ mA}$)

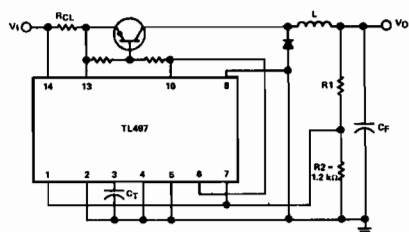

EXTENDED POWER CONFIGURATION
(USING EXTERNAL TRANSISTOR)

FIGURE 2—POSITIVE REGULATOR, STEP-DOWN CONFIGURATIONS

DESIGN EQUATIONS

- $I_{PK} = 2 I_{LOAD \text{ max}}$

- $L (\mu\text{H}) = \frac{V_I - V_O}{I_{PK}} t_{on} (\mu\text{s})$

Choose L (50 to 500 μH), calculate t_{on} (10 to 150 μs)

- $C_T (\text{pF}) \approx 12 t_{on} (\mu\text{s})$

- $R_1 = (V_O - 1.2) \text{ k}\Omega$

- $R_{CL} = \frac{0.5 \text{ V}}{I_{PK}}$

- $C_F (\mu\text{F}) \approx t_{on} \left[\frac{V_I - V_O}{V_O} I_{PK} + I_{LOAD} \right] \frac{1}{V_{RIPPLE} (\text{PK})}$

TYPES TL497AM, TL497AI, TL497AC SWITCHING VOLTAGE REGULATORS

TYPICAL APPLICATION DATA

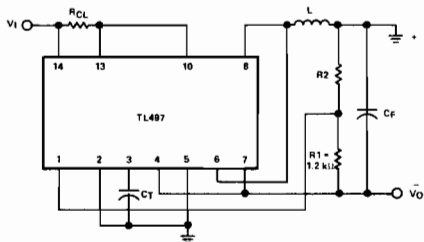

BASIC CONFIGURATION
($I_{PK} < 500 \text{ mA}$)

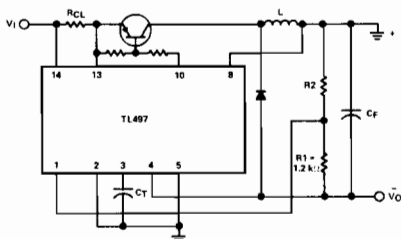

EXTENDED POWER CONFIGURATION
(USING EXTERNAL TRANSISTOR)

DESIGN EQUATIONS

$$I_{PK} = 2 I_{LOAD} \max \left[1 + \frac{|V_O|}{V_I} \right]$$

$$L (\mu\text{H}) = \frac{V_I}{I_{PK}} t_{on} (\mu\text{s})$$

Choose L (50 to 500 μH), calculate t_{on} (25 to 150 μs)

$$C_T (\text{pF}) \approx 12 t_{on} (\mu\text{s})$$

$$R_2 = (V_O - 1.2) \text{ k}\Omega$$

$$R_{CL} = \frac{0.5 \text{ V}}{I_{PK}}$$

$$C_F (\mu\text{F}) \approx t_{on} \frac{\left[\frac{V_I}{|V_O|} I_{PK} + I_{LOAD} \right]}{V_{RIPPLE(PK)}}$$

FIGURE 3—INVERTING APPLICATIONS

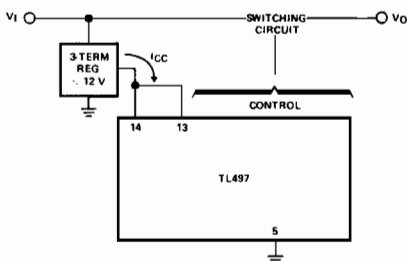

EXTENDED INPUT CONFIGURATION WITHOUT CURRENT LIMIT

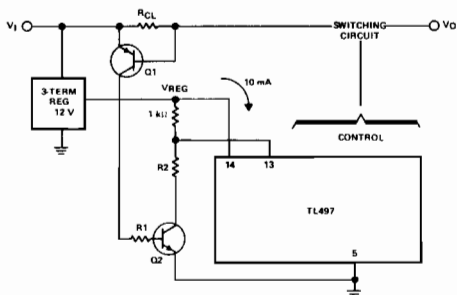

CURRENT LIMIT FOR EXTENDED INPUT CONFIGURATION

DESIGN EQUATIONS

$$R_{CL} = \frac{V_{BE(Q1)}}{I_{LIMIT(PK)}}$$

$$R_1 = \frac{V_I}{I_{B(Q2)}}$$

$$R_2 = (V_{REG} - 1) 10 \text{ k}\Omega$$

FIGURE 4—EXTENDED INPUT VOLTAGE RANGE ($V_I > 15 \text{ V}$)

- 3-Terminal Regulator
- Output Current up to 1.5 A
- No External Components
- Internal Thermal Overload Protection
- Improved Replacement for μ A7805 and LM340-05 5-Percent Regulators
- High Power Dissipation Capability
- Internal Short-Circuit Current Limiting
- Output Transistor Safe-Area Compensation

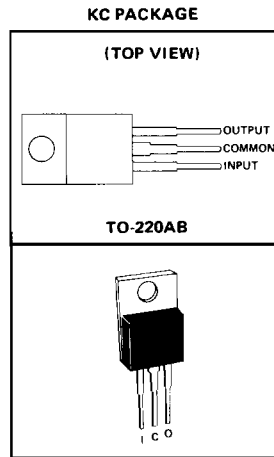

description

The TL7805AC 3-percent 5-volt regulator offers improved accuracy over the μ A7805 and LM340-05 regulators. This monolithic integrated circuit boasts an overall accuracy of better than 3-percent deviation over full line, load, and temperature variations and can deliver up to 1.5 amperes of output current. The internal current limiting and thermal shutdown features make it essentially immune to overload. In addition to use as a fixed-voltage regulator, the TL7805AC can be used with external components to obtain adjustable output voltages and currents and also can be used as the power pass element in precision regulators.

schematic

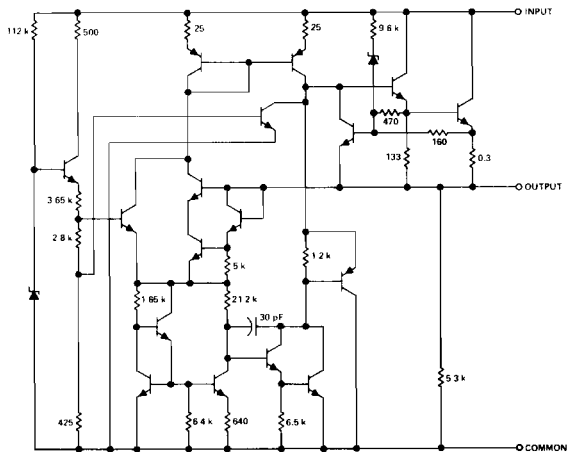

Resistor values shown are nominal and in ohms.

absolute maximum ratings over operating temperature range (unless otherwise noted)

Input voltage	35 V
Continuous total dissipation at 25°C free-air temperature (see Note 1)	2 W
Continuous total dissipation at (or below) 25° case temperature (see Note 1)	15 W
Operating free-air, case, or virtual junction temperature range	0°C to 150°C
Storage temperature range	-65°C to 150°C
Lead temperature 1/16 inch from case for 10 seconds	260°C

NOTE 1: For operation above 25°C free-air or case temperature, refer to Dissipation Derating Curves, Figure 1 and Figure 2, next page.

TYPE TL7805AC

3-PERCENT 5-VOLT REGULATOR

recommended operating conditions

	MIN	MAX	UNIT
Input voltage, V_I	7	25	V
Output current, I_O		1.5	A
Operating virtual junction temperature, T_J	0	125	°C

electrical characteristics at specified virtual junction temperature, $V_I = 10\text{ V}$, $I_O = 500\text{ mA}$
(unless otherwise noted)

PARAMETER	TEST CONDITIONS†		MIN	TYP	MAX	UNIT
	$I_O = 5\text{ mA to }1\text{ A}$, $P \leq 15\text{ W}$	$V_I = 7\text{ V to }20\text{ V}$, 25°C	4.9	5	5.1	
Output voltage		0°C to 125°C	4.85		5.15	V
Input regulation	$V_I = 7\text{ V to }25\text{ V}$	25°C		3	50	mV
	$V_I = 8\text{ V to }12\text{ V}$			1	25	
Ripple rejection	$V_I = 8\text{ V to }18\text{ V}$, $f = 120\text{ Hz}$	0°C to 125°C	62	78		dB
Output regulation	$I_O = 5\text{ mA to }1.5\text{ A}$	25°C		15	100	mV
	$I_O = 250\text{ mA to }750\text{ mA}$			5	50	
Output resistance	$f = 1\text{ kHz}$	0°C to 125°C		0.017		Ω
Temperature coefficient of output voltage	$I_O = 5\text{ mA}$	0°C to 125°C		-1.1		mV/°C
Output noise voltage	$f = 10\text{ Hz to }100\text{ kHz}$	25°C		40		μV
Dropout voltage	$I_O = 1\text{ A}$	25°C		2.0		V
Bias current		25°C		4.2	8	mA
Bias current change	$V_I = 7\text{ V to }25\text{ V}$	0°C to 125°C			1.3	mA
	$I_O = 5\text{ mA to }1\text{ A}$				0.5	
Short-circuit output current		25°C		750		mA
Peak output current		25°C		2.2		A

† All characteristics are measured with a capacitor across the input of 0.33 μF and a capacitor across the output of 0.1 μF. All characteristics except noise voltage and ripple rejection ratio are measured using pulse techniques ($t_w \leq 10\text{ ms}$, duty cycles $\leq 5\%$). Output voltage changes due to changes in internal temperature must be taken into account separately.

THERMAL INFORMATION

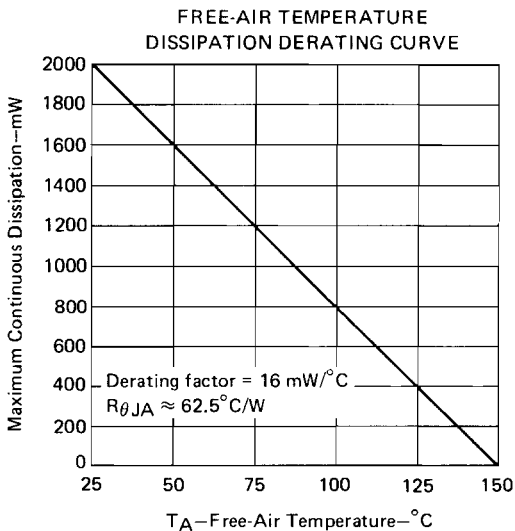

FIGURE 1

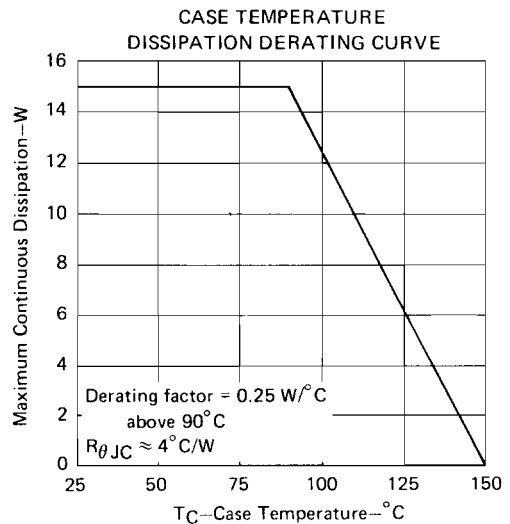

FIGURE 2

FORMERLY SN52723, SN72723

- 150-mA Load Current without External Power Transistor
- Typically 0.02% Input Regulation and 0.03% Load Regulation (μ A723M)
- Adjustable Current Limiting Capability
- Input Voltages to 40 Volts
- Output Adjustable from 2 to 37 Volts
- Designed to be Interchangeable with Fairchild μ A723 and μ A723C Respectively

description

The μ A723M and μ A723C are monolithic integrated circuit voltage regulators featuring high ripple rejection, excellent input and load regulation, excellent temperature stability, and low standby current. The circuit consists of a temperature-compensated reference voltage amplifier, an error amplifier, a 150-milliampere output transistor, and an adjustable output current limiter.

The μ A723M and μ A723C are designed for use in positive or negative power supplies as a series, shunt, switching, or floating regulator. For output currents exceeding 150 mA, additional pass elements may be connected as shown in Figures 4 and 5.

The μ A723M is characterized for operation over the full military temperature range of -55°C to 125°C ; the μ A723C is characterized for operation from 0°C to 70°C .

terminal assignments

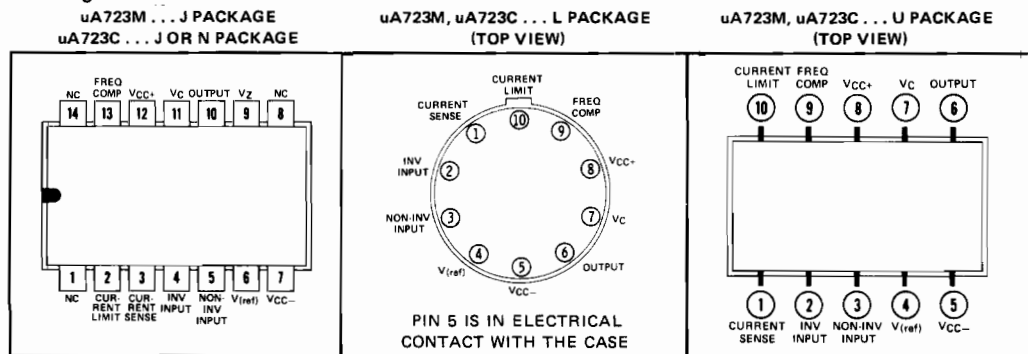

NC—No internal connection

functional block diagram

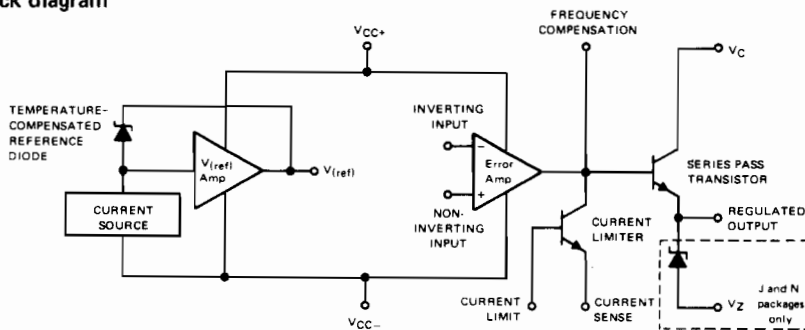

TYPES μ A723M, μ A723C PRECISION VOLTAGE REGULATORS

schematic

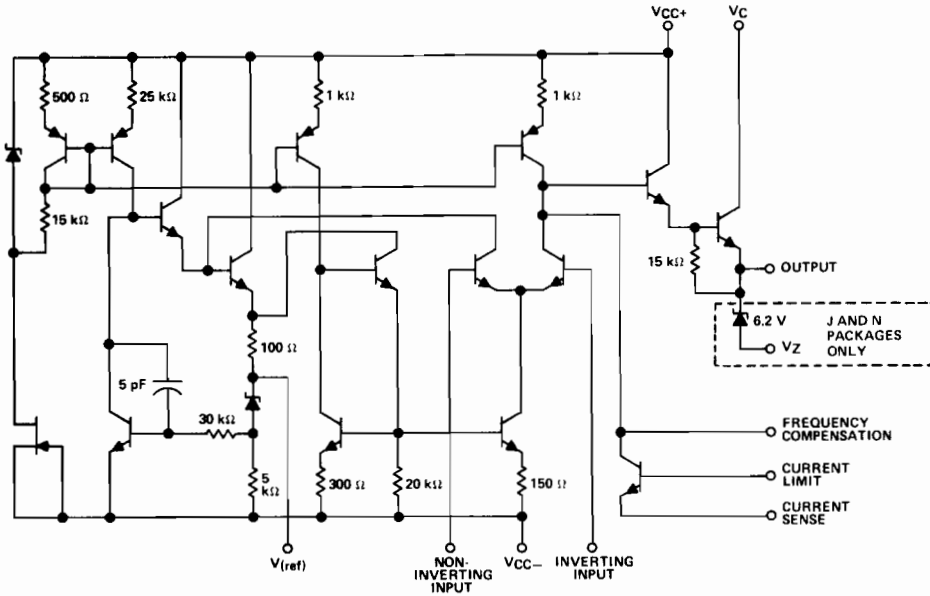

DISSIPATION DERATING TABLE

PACKAGE	POWER RATING	DERATING FACTOR	ABOVE T_A
J	1000 mW	8.2 mW/°C	28°C
L + heat sink [†]	800 mW	6.4 mW/°C	25°C
N	1000 mW	9.2 mW/°C	41°C
U	675 mW	5.4 mW/°C	25°C

[†]This rating for the L package requires a heat sink that provides a thermal resistance from case to free-air, $R_{\theta CA}$, of not more than 105°C/W.

TYPES μ A723M, μ A723C

PRECISION VOLTAGE REGULATORS

TABLE I
RESISTOR VALUES (k Ω) FOR STANDARD OUTPUT VOLTAGES

OUTPUT VOLTAGE (V)	APPLICABLE FIGURES (SEE NOTE 4)	FIXED OUTPUT $\pm 5\%$		OUTPUT ADJUSTABLE $\pm 10\%$ (SEE NOTE 5)			OUTPUT VOLTAGE (V)	APPLICABLE FIGURES (SEE NOTE 4)	FIXED OUTPUT $\pm 5\%$		OUTPUT ADJUSTABLE $\pm 10\%$ (SEE NOTE 5)		
		R1 (k Ω)	R2 (k Ω)	R1 (k Ω)	P1 (k Ω)	R2 (k Ω)			R1 (k Ω)	R2 (k Ω)	R1 (k Ω)	P1 (k Ω)	R2 (k Ω)
+3.0	1, 5, 6, 9, 11, 12 (4)	4.12	3.01	1.8	0.5	1.2	+100	7	3.57	105	2.2	10	91
+3.6	1, 5, 6, 9, 11, 12 (4)	3.57	3.65	1.5	0.5	1.5	+250	7	3.57	255	2.2	10	240
+5.0	1, 5, 6, 9, 11, 12 (4)	2.15	4.99	0.75	0.5	2.2	-6 (Note 6)	3, (10)	3.57	2.43	1.2	0.5	0.75
+6.0	1, 5, 6, 9, 11, 12 (4)	1.15	6.04	0.5	0.5	2.7	-9	3, 10	3.48	5.36	1.2	0.5	2.0
+9.0	2, 4, (5, 6, 9, 12)	1.87	7.15	0.75	1.0	2.7	-12	3, 10	3.57	8.45	1.2	0.5	3.3
+12	2, 4, (5, 6, 9, 12)	4.87	7.15	2.0	1.0	3.0	-15	3, 10	3.57	11.5	1.2	0.5	4.3
+15	2, 4, (5, 6, 9, 12)	7.87	7.15	3.3	1.0	3.0	-28	3, 10	3.57	24.3	1.2	0.5	10
+28	2, 4, (5, 6, 9, 12)	21.0	7.15	5.6	1.0	2.0	-45	8	3.57	41.2	2.2	10	33
+45	7	3.57	48.7	2.2	10	39	-100	8	3.57	95.3	2.2	10	91
+75	7	3.57	78.7	2.2	10	68	-250	8	3.57	249	2.2	10	240

TABLE II
FORMULAS FOR INTERMEDIATE OUTPUT VOLTAGES

<p>Outputs from +2 to +7 volts [Figures 1, 5, 6, 9, 11, 12, (4)]</p> $V_O = V_{(ref)} \times \frac{R_2}{R_1 + R_2}$	<p>Outputs from +4 to +250 volts [Figure 7]</p> $V_O = \frac{V_{(ref)}}{2} \times \frac{R_2 - R_1}{R_1};$ <p>R3 = R4</p>	<p>Current Limiting</p> $I_{(limit)} \approx \frac{0.65 \text{ V}}{R_{sc}}$
<p>Outputs from +7 to +37 volts [Figures 2, 4, (5, 6, 9, 11, 12)]</p> $V_O = V_{(ref)} \times \frac{R_1 + R_2}{R_2}$	<p>Outputs from -6 to -250 volts [Figures 3, 8, 10]</p> $V_O = -\frac{V_{(ref)}}{2} \times \frac{R_1 + R_2}{R_1};$ <p>R3 = R4</p>	<p>Foldback Current Limiting [Figure 6]</p> $I_{(knee)} \approx \frac{V_O R_3 + (R_3 + R_4) 0.65 \text{ V}}{R_{sc} R_4};$ $I_{OS} \approx \frac{0.65 \text{ V}}{R_{sc}} \times \frac{R_3 + R_4}{R_4}$

- NOTES: 4. Figures 1 through 12 show the R1/R2 divider across either V_O or $V_{(ref)}$. Figure numbers in parentheses may be used if the R1/R2 divider is placed across the other voltage ($V_{(ref)}$ or V_O) that it was not placed across in the figures without parentheses.
5. To make the voltage adjustable, the R1/R2 divider shown in the figures must be replaced by the divider shown at the right.
6. For negative output voltages less than 9 V, V_{CC+} and V_C must be connected to a positive supply such that the voltage between V_{CC+} and V_{CC-} is greater than 9 V.
7. When 10-lead μ A723 devices are used in applications requiring V_Z , an external 6.2-V regulator diode must be connected in series with the V_O terminal.

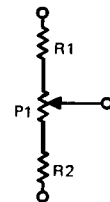

ADJUSTABLE OUTPUT CIRCUITS

TYPES μ A723M, μ A723C PRECISION VOLTAGE REGULATORS

TYPICAL APPLICATION DATA

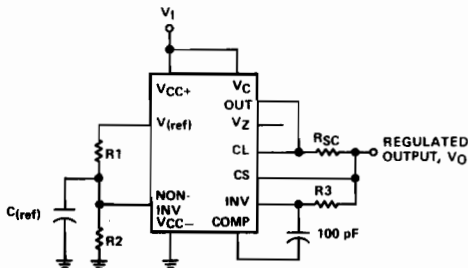

NOTES: A. $R_3 = \frac{R_1 \cdot R_2}{R_1 + R_2}$ for minimum αV_O .

B. R_3 may be eliminated for minimum component count. Use direct connection (i.e., $R_3 = 0$).

FIGURE 1—BASIC LOW-VOLTAGE REGULATOR
($V_O = 2$ TO 7 VOLTS)

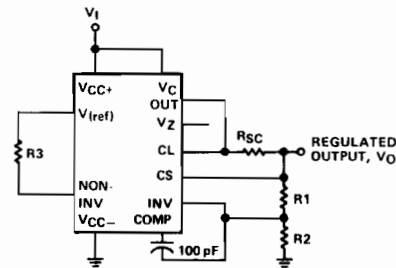

NOTES: A. $R_3 = \frac{R_1 \cdot R_2}{R_1 + R_2}$ for minimum αV_O .

B. R_3 may be eliminated for minimum component count. Use direct connection (i.e., $R_3 = 0$).

FIGURE 2—BASIC HIGH-VOLTAGE REGULATOR
($V_O = 7$ TO 37 VOLTS)

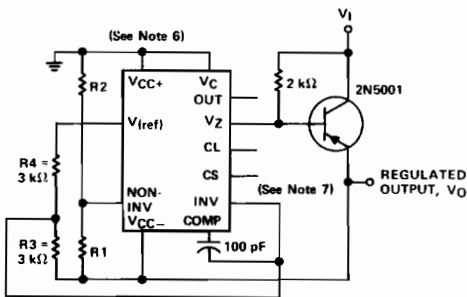

FIGURE 3—NEGATIVE-VOLTAGE REGULATOR

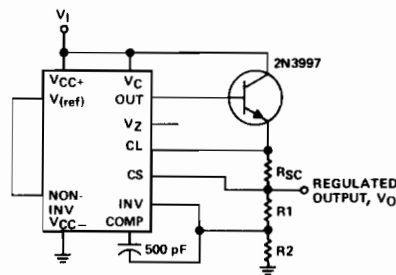

FIGURE 4—POSITIVE-VOLTAGE REGULATOR
(EXTERNAL N-P-N PASS TRANSISTOR)

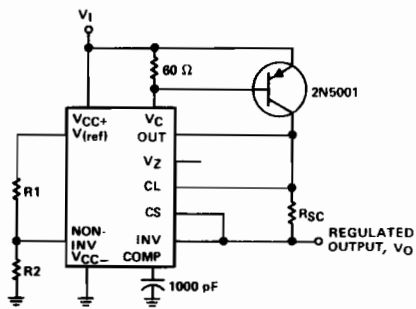

FIGURE 5—POSITIVE-VOLTAGE REGULATOR
(EXTERNAL P-N-P PASS TRANSISTOR)

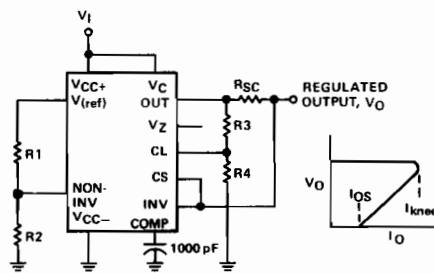

FIGURE 6—FOLDBACK CURRENT LIMITING

TYPES μ A723M, μ A723C

PRECISION VOLTAGE REGULATORS

TYPICAL APPLICATION DATA

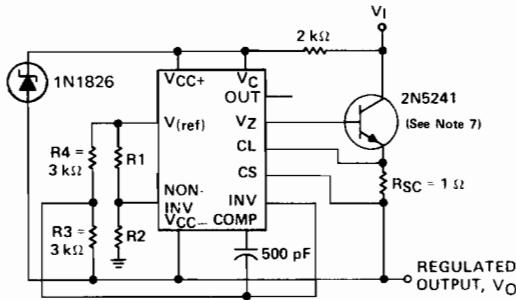

FIGURE 7—POSITIVE FLOATING REGULATOR

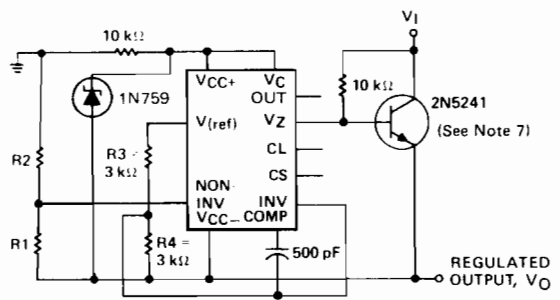

FIGURE 8—NEGATIVE FLOATING REGULATOR

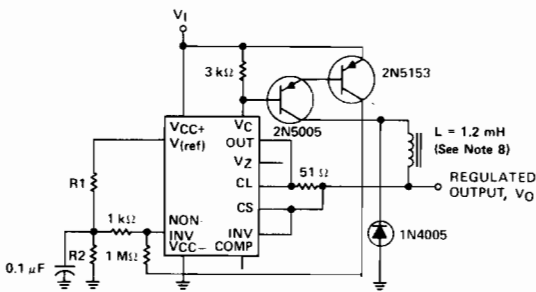

FIGURE 9—POSITIVE SWITCHING REGULATOR

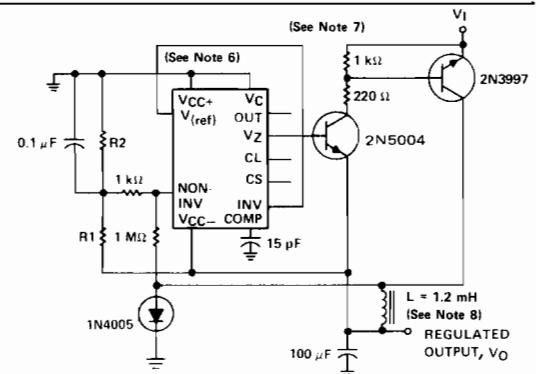
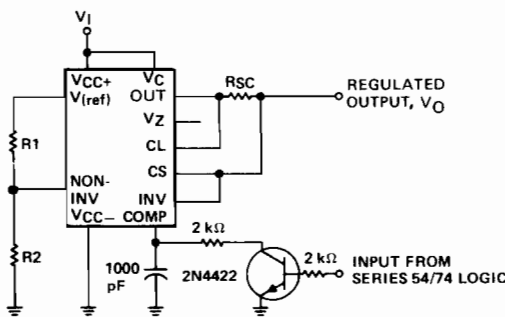

FIGURE 10—NEGATIVE SWITCHING REGULATOR



NOTE A: Current limit transistor may be used for shutdown if current limiting is not required.

FIGURE 11—REMOTE SHUTDOWN REGULATOR WITH CURRENT LIMITING

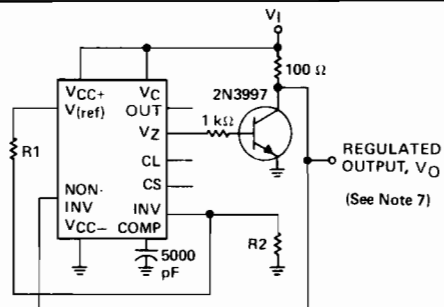

FIGURE 12—SHUNT REGULATOR

- NOTES:
- For negative output voltages less than 9 V, V_{CC+} and V_C must be connected to a positive supply such that the voltage between V_{CC+} and V_{CC-} is greater than 9 V.
 - When 10-lead μ A723 devices are used in applications requiring V_Z , an external 6.2-V regulator diode must be connected in series with the V_O terminal.
 - L is 40 turns of No. 20 enameled copper wire wound on Ferroxcube P36/22-3B7 potted core, or equivalent, with 0.009-inch air gap.

LINEAR INTEGRATED CIRCUITS

SERIES μ A7800 POSITIVE-VOLTAGE REGULATORS

BULLETIN NO. DL-S 12386, MAY 1976—REVISED SEPTEMBER 1977

- 3-Terminal Regulators
- Output Current up to 1.5 A
- No External Components
- Internal Thermal Overload Protection
- Direct Replacements for Fairchild μ A7800 Series
- High Power Dissipation Capability
- Internal Short-Circuit Current Limiting
- Output Transistor Safe-Area Compensation

NOMINAL OUTPUT VOLTAGE	REGULATOR
5 V	μ A7805C
6 V	μ A7806C
8 V	μ A7808C
8.5 V	μ A7885C
10 V	μ A7810C
12 V	μ A7812C
15 V	μ A7815C
18 V	μ A7818C
22 V	μ A7822C
24 V	μ A7824C

description

This series of fixed-voltage monolithic integrated-circuit voltage regulators is designed for a wide range of applications. These applications include on-card regulation for elimination of noise and distribution problems associated with single-point regulation. One of these regulators can deliver up to 1.5 amperes of output current. The internal current limiting and thermal shutdown features of these regulators make them essentially immune to overload. In addition to use as fixed-voltage regulators, these devices can be used with external components to obtain adjustable output voltages and currents and also as the power-pass element in precision regulators.

KC PACKAGE

(TOP VIEW)

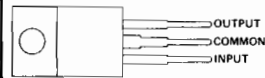

TO-220AB



schematic

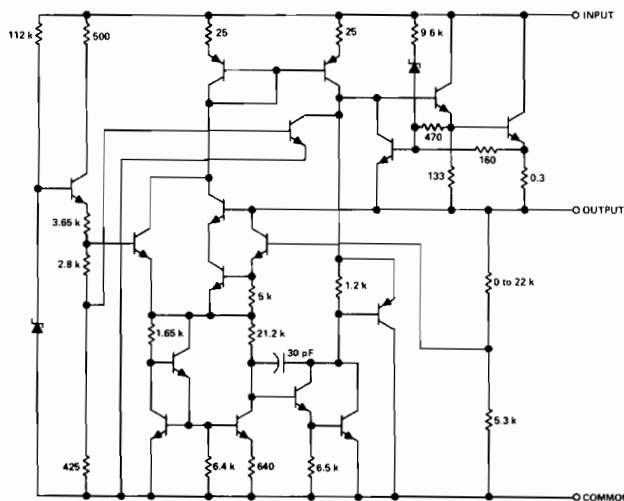

Resistor values shown are nominal and in ohms.

Copyright ©1977 by Texas Instruments Incorporated

TEXAS INSTRUMENTS
INCORPORATED
POST OFFICE BOX 5012 • DALLAS, TEXAS 75222

SERIES μ A7800

POSITIVE-VOLTAGE REGULATORS

absolute maximum ratings over operating temperature range (unless otherwise noted)

	μ A78__C	UNIT
Input voltage	μ A7822C, μ A7824C	40
	All others	35
Continuous total dissipation at 25°C free-air temperature (see Note 1)		2
Continuous total dissipation at (or below) 25°C case temperature (see Note 1)		15
Operating free-air, case, or virtual junction temperature range		0 to 150
Storage temperature range		-65 to 150
Lead temperature 1/16 inch from case for 10 seconds		260

Note 1: For operation above 25°C free-air or case temperature, refer to Dissipation Derating Curves, Figure 1 and Figure 2.

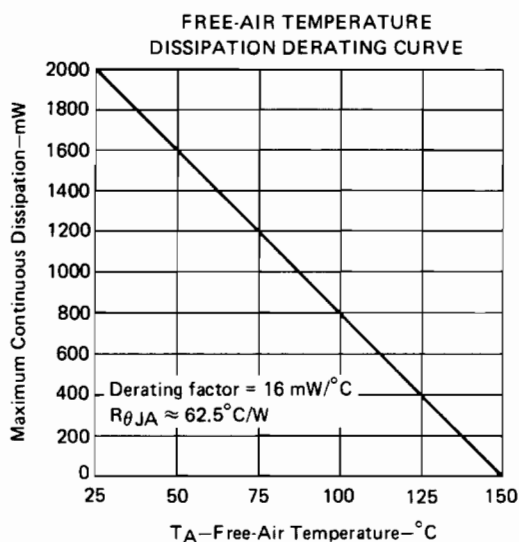

FIGURE 1

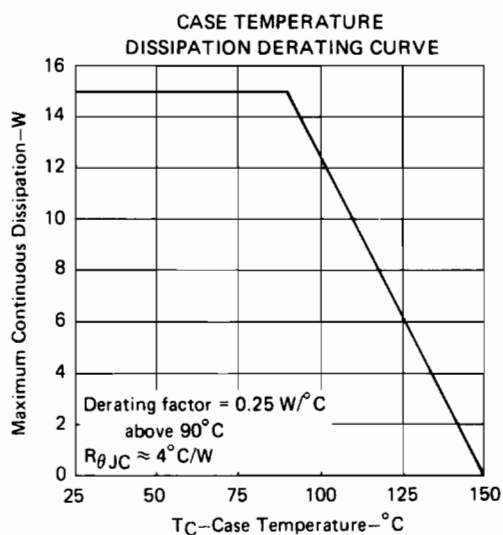

FIGURE 2

recommended operating conditions

	MIN	MAX	UNIT
Input voltage, V_I	μ A7805C	7	25
	μ A7806C	8	25
	μ A7808C	10.5	25
	μ A7885C	10.5	25
	μ A7810C	12.5	28
	μ A7812C	14.5	30
	μ A7815C	17.5	30
	μ A7818C	21	33
	μ A7822C	25	36
	μ A7824C	27	38
Output current, I_O		1.5	A
Operating virtual junction temperature, T_J	0	125	°C

TYPES μ A7805C, μ A7806C POSITIVE-VOLTAGE REGULATORS

μ A7805C electrical characteristics at specified virtual junction temperature,
 $V_I = 10\text{ V}$, $I_O = 500\text{ mA}$ (unless otherwise noted)

PARAMETER	TEST CONDITIONS†	μ A7805C			UNIT	
		MIN	TYP	MAX		
Output voltage	$I_O = 5\text{ mA to }1\text{ A}$, $P \leq 15\text{ W}$ $V_I = 7\text{ V to }20\text{ V}$	25°C	4.8	5	5.2	V
		$0^\circ\text{C to }125^\circ\text{C}$	4.75		5.25	
Input regulation	$V_I = 7\text{ V to }25\text{ V}$	25°C		3	100	mV
	$V_I = 8\text{ V to }12\text{ V}$			1	50	
Ripple rejection	$V_I = 8\text{ V to }18\text{ V}$, $f = 120\text{ Hz}$	$0^\circ\text{C to }125^\circ\text{C}$	62	78		dB
Output regulation	$I_O = 5\text{ mA to }1.5\text{ A}$	25°C		15	100	mV
	$I_O = 250\text{ mA to }750\text{ mA}$			5	50	
Output resistance	$f = 1\text{ kHz}$	$0^\circ\text{C to }125^\circ\text{C}$	0.017			Ω
Temperature coefficient of output voltage	$I_O = 5\text{ mA}$	$0^\circ\text{C to }125^\circ\text{C}$	-1.1			$\text{mV}/^\circ\text{C}$
Output noise voltage	$f = 10\text{ Hz to }100\text{ kHz}$	25°C	40			μV
Dropout voltage	$I_O = 1\text{ A}$	25°C	2.0			V
Bias current		25°C	4.2	8		mA
Bias current change	$V_I = 7\text{ V to }25\text{ V}$	$0^\circ\text{C to }125^\circ\text{C}$			1.3	mA
	$I_O = 5\text{ mA to }1\text{ A}$				0.5	
Short-circuit output current		25°C	750			mA
Peak output current		25°C	2.2			A

μ A7806C electrical characteristics at specified virtual junction temperature,
 $V_I = 11\text{ V}$, $I_O = 500\text{ mA}$ (unless otherwise noted)

PARAMETER	TEST CONDITIONS†	μ A7806C			UNIT	
		MIN	TYP	MAX		
Output voltage	$I_O = 5\text{ mA to }1\text{ A}$, $P \leq 15\text{ W}$ $V_I = 8\text{ V to }21\text{ V}$	25°C	5.75	6	6.25	V
		$0^\circ\text{C to }125^\circ\text{C}$	5.7		6.3	
Input regulation	$V_I = 8\text{ V to }25\text{ V}$	25°C		5	120	mV
	$V_I = 9\text{ V to }13\text{ V}$			1.5	60	
Ripple rejection	$V_I = 9\text{ V to }19\text{ V}$, $f = 120\text{ Hz}$	$0^\circ\text{C to }125^\circ\text{C}$	59	75		dB
Output regulation	$I_O = 5\text{ mA to }1.5\text{ A}$	25°C		14	120	mV
	$I_O = 250\text{ mA to }750\text{ mA}$			4	60	
Output resistance	$f = 1\text{ kHz}$	$0^\circ\text{C to }125^\circ\text{C}$	0.019			Ω
Temperature coefficient of output voltage	$I_O = 5\text{ mA}$	$0^\circ\text{C to }125^\circ\text{C}$	-0.8			$\text{mV}/^\circ\text{C}$
Output noise voltage	$f = 10\text{ Hz to }100\text{ kHz}$	25°C	45			μV
Dropout voltage	$I_O = 1\text{ A}$	25°C	2.0			V
Bias current		25°C	4.3	8		mA
Bias current change	$V_I = 8\text{ V to }25\text{ V}$	$0^\circ\text{C to }125^\circ\text{C}$			1.3	mA
	$I_O = 5\text{ mA to }1\text{ A}$				0.5	
Short-circuit output current		25°C	550			mA
Peak output current		25°C	2.2			A

† All characteristics are measured with a capacitor across the input of $0.33\ \mu\text{F}$ and a capacitor across the output of $0.1\ \mu\text{F}$. All characteristics except noise voltage and ripple rejection ratio are measured using pulse techniques ($t_w \leq 10\text{ ms}$, duty cycles $\leq 5\%$). Output voltage changes due to changes in internal temperature must be taken into account separately.

TYPES μ A7808C, μ A7885C

POSITIVE-VOLTAGE REGULATORS

μ A7808C electrical characteristics at specified virtual junction temperature,
 $V_I = 14$ V, $I_O = 500$ mA (unless otherwise noted)

PARAMETER	TEST CONDITIONS†	μ A7808C			UNIT	
		MIN	TYP	MAX		
Output voltage		25°C	7.7	8	8.3	V
	$I_O = 5$ mA to 1 A, $V_I = 10.5$ V to 23 V, $P \leq 15$ W	0°C to 125°C	7.6		8.4	
Input regulation	$V_I = 10.5$ V to 25 V	25°C		6	160	mV
	$V_I = 11$ V to 17 V			2	80	
Ripple rejection	$V_I = 11.5$ V to 21.5 V, $f = 120$ Hz	0°C to 125°C	56	72		dB
Output regulation	$I_O = 5$ mA to 1.5 A	25°C		12	160	mV
	$I_O = 250$ mA to 750 mA			4	80	
Output resistance	$f = 1$ kHz	0°C to 125°C	0.016			Ω
Temperature coefficient of output voltage	$I_O = 5$ mA	0°C to 125°C	-0.8			mV/°C
Output noise voltage	$f = 10$ Hz to 100 kHz	25°C	52			μ V
Dropout voltage	$I_O = 1$ A	25°C	2.0			V
Bias current		25°C	4.3		8	mA
Bias current change	$V_I = 10.5$ V to 25 V	0°C to 125°C			1	mA
	$I_O = 5$ mA to 1 A				0.5	
Short-circuit output current		25°C	450			mA
Peak output current		25°C	2.2			A

μ A7885C electrical characteristics at specified virtual junction temperature,
 $V_I = 15$ V, $I_O = 500$ mA (unless otherwise noted)

PARAMETER	TEST CONDITIONS†	μ A7885C			UNIT	
		MIN	TYP	MAX		
Output voltage		25°C	8.15	8.5	8.85	V
	$I_O = 5$ mA to 1 A, $V_I = 11$ V to 23.5 V, $P \leq 15$ W	0°C to 125°C	8.1		8.9	
Input regulation	$V_I = 10.5$ V to 25 V	25°C		6	170	mV
	$V_I = 11$ V to 17 V			2	85	
Ripple rejection	$V_I = 11.5$ V to 21.5 V, $f = 120$ Hz	0°C to 125°C	54	70		dB
Output regulation	$I_O = 5$ mA to 1.5 A	25°C		12	170	mV
	$I_O = 250$ mA to 750 mA			4	85	
Output resistance	$f = 1$ kHz	0°C to 125°C	0.016			Ω
Temperature coefficient of output voltage	$I_O = 5$ mA	0°C to 125°C	-0.8			mV/°C
Output noise voltage	$f = 10$ Hz to 100 kHz	25°C	55			μ V
Dropout voltage	$I_O = 1$ A	25°C	2.0			V
Bias current		25°C	4.3		8	mA
Bias current change	$V_I = 10.5$ V to 25 V	0°C to 125°C			1	mA
	$I_O = 5$ mA to 1 A				0.5	
Short-circuit output current		25°C	450			mA
Peak output current		25°C	2.2			A

† All characteristics are measured with a capacitor across the input of 0.33 μ F and a capacitor across the output of 0.1 μ F. All characteristics except noise voltage and ripple rejection ratio are measured using pulse techniques ($t_W \leq 10$ ms, duty cycles $\leq 5\%$). Output voltage changes due to changes in internal temperature must be taken into account separately.

TYPES μ A7810C, μ A7812C POSITIVE-VOLTAGE REGULATORS

μ A7810C electrical characteristics at specified virtual junction temperature,
 $V_I = 17\text{ V}$, $I_O = 500\text{ mA}$ (unless otherwise noted)

PARAMETER	TEST CONDITIONS [†]	μ A7810C			UNIT	
		MIN	TYP	MAX		
Output voltage	$I_O = 5\text{ mA to }1\text{ A}$, $V_I = 12.5\text{ V to }25\text{ V}$, $P \leq 15\text{ W}$	25°C	9.6	10	10.4	V
		0°C to 125°C	9.5	10	10.5	
Input regulation	$V_I = 12.5\text{ V to }28\text{ V}$	25°C	7		200	mV
	$V_I = 14\text{ V to }20\text{ V}$		2		100	
Ripple rejection	$V_I = 13\text{ V to }23\text{ V}$, $f = 120\text{ Hz}$	0°C to 125°C	55	71		dB
Output regulation	$I_O = 5\text{ mA to }1.5\text{ A}$	25°C	12		200	mV
	$I_O = 250\text{ mA to }750\text{ mA}$		4		100	
Output resistance	$f = 1\text{ kHz}$	0°C to 125°C	0.018			Ω
Temperature coefficient of output voltage	$I_O = 5\text{ mA}$	0°C to 125°C	-1.0			mV/°C
Output noise voltage	$f = 10\text{ Hz to }100\text{ kHz}$	25°C	70			μV
Dropout voltage	$I_O = 1\text{ A}$	25°C	2.0			V
Bias current		25°C	4.3		8	mA
Bias current change	$V_I = 12.5\text{ V to }28\text{ V}$	0°C to 125°C			1	mA
	$I_O = 5\text{ mA to }1\text{ A}$				0.5	
Short-circuit output current		25°C	400			mA
Peak output current		25°C	2.2			A

μ A7812C electrical characteristics at specified virtual junction temperature,
 $V_I = 19\text{ V}$, $I_O = 500\text{ mA}$ (unless otherwise noted)

PARAMETER	TEST CONDITIONS [†]	μ A7812C			UNIT	
		MIN	TYP	MAX		
Output voltage	$I_O = 5\text{ mA to }1\text{ A}$, $V_I = 14.5\text{ V to }27\text{ V}$, $P \leq 15\text{ W}$	25°C	11.5	12	12.5	V
		0°C to 125°C	11.4		12.6	
Input regulation	$V_I = 14.5\text{ V to }30\text{ V}$	25°C	10		240	mV
	$V_I = 16\text{ V to }22\text{ V}$		3		120	
Ripple rejection	$V_I = 15\text{ V to }25\text{ V}$, $f = 120\text{ Hz}$	0°C to 125°C	55	71		dB
Output regulation	$I_O = 5\text{ mA to }1.5\text{ A}$	25°C	12		240	mV
	$I_O = 250\text{ mA to }750\text{ mA}$		4		120	
Output resistance	$f = 1\text{ kHz}$	0°C to 125°C	0.018			Ω
Temperature coefficient of output voltage	$I_O = 5\text{ mA}$	0°C to 125°C	-1.0			mV/°C
Output noise voltage	$f = 10\text{ Hz to }100\text{ kHz}$	25°C	75			μV
Dropout voltage	$I_O = 1\text{ A}$	25°C	2.0			V
Bias current		25°C	4.3		8	mA
Bias current change	$V_I = 14.5\text{ V to }30\text{ V}$	0°C to 125°C			1	mA
	$I_O = 5\text{ mA to }1\text{ A}$				0.5	
Short-circuit output current		25°C	350			mA
Peak output current		25°C	2.2			A

[†]All characteristics are measured with a capacitor across the input of 0.33 μF and a capacitor across the output of 0.1 μF . All characteristics except noise voltage and ripple rejection ratio are measured using pulse techniques ($t_{\text{pw}} \leq 10\text{ ms}$, duty cycles $\leq 5\%$). Output voltage changes due to changes in internal temperature must be taken into account separately.

TYPES μ A7815C, μ A7818C

POSITIVE-VOLTAGE REGULATORS

μ A7815C electrical characteristics at specified virtual junction temperature,
 $V_I = 23$ V, $I_O = 500$ mA (unless otherwise noted)

PARAMETER	TEST CONDITIONS†		μ A7815C			UNIT
			MIN	TYP	MAX	
Output voltage	$I_O = 5$ mA to 1 A, $V_I = 17.5$ V to 30 V, $P \leq 15$ W	25°C	14.4	15	15.6	V
		0°C to 125°C	14.25		15.75	
Input regulation	$V_I = 17.5$ V to 30 V	25°C		11	300	mV
	$V_I = 20$ V to 26 V			3	150	
Ripple rejection	$V_I = 18.5$ V to 28.5 V, $f = 120$ Hz	0°C to 125°C	54	70		dB
Output regulation	$I_O = 5$ mA to 1.5 A	25°C		12	300	mV
	$I_O = 250$ mA to 750 mA			4	150	
Output resistance	$f = 1$ kHz	0°C to 125°C	0.019			Ω
Temperature coefficient of output voltage	$I_O = 5$ mA	0°C to 125°C		-1.0		mV/°C
Output noise voltage	$f = 10$ Hz to 100 kHz	25°C		90		μ V
Dropout voltage	$I_O = 1$ A	25°C		2.0		V
Bias current		25°C		4.4	8	mA
Bias current change	$V_I = 17.5$ V to 30 V	0°C to 125°C			1	mA
	$I_O = 5$ mA to 1 A				0.5	
Short-circuit output current		25°C		230		mA
Peak output current		25°C		2.1		A

μ A7818C electrical characteristics at specified virtual junction temperature,
 $V_I = 27$ V, $I_O = 500$ mA (unless otherwise noted)

PARAMETER	TEST CONDITIONS†		μ A7818C			UNIT
			MIN	TYP	MAX	
Output voltage	$I_O = 5$ mA to 1 A, $V_I = 21$ V to 33 V, $P \leq 15$ W	25°C	17.3	18	18.7	V
		0°C to 125°C	17.1		18.9	
Input regulation	$V_I = 21$ V to 33 V	25°C		15	360	mV
	$V_I = 24$ V to 30 V			5	180	
Ripple rejection	$V_I = 22$ V to 32 V, $f = 120$ Hz	0°C to 125°C	53	69		dB
Output regulation	$I_O = 5$ mA to 1.5 A	25°C		12	360	mV
	$I_O = 250$ mA to 750 mA			4	180	
Output resistance	$f = 1$ kHz	0°C to 125°C	0.022			Ω
Temperature coefficient of output voltage	$I_O = 5$ mA	0°C to 125°C		-1.0		mV/°C
Output noise voltage	$f = 10$ Hz to 100 kHz	25°C		110		μ V
Dropout voltage	$I_O = 1$ A	25°C		2.0		V
Bias current		25°C		4.5	8	mA
Bias current change	$V_I = 21$ V to 33 V	0°C to 125°C			1	mA
	$I_O = 5$ mA to 1 A				0.5	
Short-circuit output current		25°C		200		mA
Peak output current		25°C		2.1		A

† All characteristics are measured with a capacitor across the input of 0.33 μ F and a capacitor across the output of 0.1 μ F. All characteristics except noise voltage and ripple rejection ratio are measured using pulse techniques ($t_w \leq 10$ ms, duty cycles $\leq 5\%$). Output voltage changes due to changes in internal temperature must be taken into account separately.

TYPES μ A7822C, μ A7824C POSITIVE-VOLTAGE REGULATORS

μ A7822C electrical characteristics at specified virtual junction temperature,
 $V_I = 31$ V, $I_O = 500$ mA (unless otherwise noted)

PARAMETER	TEST CONDITIONS†	μ A7822C			UNIT	
		MIN	TYP	MAX		
Output voltage	$I_O = 5$ mA to 1 A, $V_I = 25$ V to 36 V, $P \leq 15$ W	25°C	21.1	22	22.9	V
		0°C to 125°C	20.9		23.1	
Input regulation	$V_I = 25$ V to 36 V	25°C		17	440	mV
	$V_I = 26$ V to 34 V			6	220	
Ripple rejection	$V_I = 26$ V to 36 V, $f = 120$ Hz	0°C to 125°C	51	67		dB
Output regulation	$I_O = 5$ mA to 1.5 A	25°C		12	440	mV
	$I_O = 250$ mA to 750 mA			4	220	
Output resistance	$f = 1$ kHz	0°C to 125°C	0.028			Ω
Temperature coefficient of output voltage	$I_O = 5$ mA	0°C to 125°C	-1.3			mV/°C
Output noise voltage	$f = 10$ Hz to 100 kHz	25°C	160			μ V
Dropout voltage	$I_O = 1$ A	25°C	2.0			V
Bias current		25°C	4.6	8		mA
Bias current change	$V_I = 25$ V to 36 V	0°C to 125°C			1	mA
	$I_O = 5$ mA to 1 A				0.5	
Short-circuit output current		25°C	175			mA
Peak output current		25°C	2.1			A

μ A7824C electrical characteristics at specified virtual junction temperature,
 $V_I = 33$ V, $I_O = 500$ mA (unless otherwise noted)

PARAMETER	TEST CONDITIONS†	μ A7824C			UNIT	
		MIN	TYP	MAX		
Output voltage	$I_O = 5$ mA to 1 A, $V_I = 27$ V to 38 V, $P \leq 15$ W	25°C	23	24	25	V
		0°C to 125°C	22.8		25.2	
Input regulation	$V_I = 27$ V to 38 V	25°C		18	480	mV
	$V_I = 30$ V to 36 V			6	240	
Ripple rejection	$V_I = 28$ V to 38 V, $f = 120$ Hz	0°C to 125°C	50	66		dB
Output regulation	$I_O = 5$ mA to 1.5 A	25°C		12	480	mV
	$I_O = 250$ mA to 750 mA			4	240	
Output resistance	$f = 1$ kHz	0°C to 125°C	0.028			Ω
Temperature coefficient of output voltage	$I_O = 5$ mA	0°C to 125°C	-1.5			mV/°C
Output noise voltage	$f = 10$ Hz to 100 kHz	25°C	170			μ V
Dropout voltage	$I_O = 1$ A	25°C	2.0			V
Bias current		25°C	4.6	8		mA
Bias current change	$V_I = 27$ V to 38 V	0°C to 125°C			1	mA
	$I_O = 5$ mA to 1 A				0.5	
Short-circuit output current		25°C	150			mA
Peak output current		25°C	2.1			A

† All characteristics are measured with a capacitor across the input of 0.33 μ F and a capacitor across the output of 0.1 μ F. All characteristics except noise voltage and ripple rejection ratio are measured using pulse techniques ($t_W \leq 10$ ms, duty cycles $\leq 5\%$). Output voltage changes due to changes in internal temperature must be taken into account separately.

LINEAR INTEGRATED CIRCUITS

SERIES μ A78L00 POSITIVE-VOLTAGE REGULATORS

BULLETIN NO. DL-S 12353, JANUARY 1976—REVISED APRIL 1977

- 3-Terminal Regulators
- Output Current up to 100 mA
- No External Components
- Internal Thermal Overload Protection
- Unusually High Power Dissipation Capability
- Direct Replacement for Fairchild μ A78L00 Series
- Internal Short-Circuit Current Limiting

NOMINAL OUTPUT VOLTAGE	5% TOLERANCE	10% TOLERANCE
2.6 V	μ A78L02AC	μ A78L02C
5 V	μ A78L05AC	μ A78L05C
6.2 V	μ A78L06AC	μ A78L06C
8 V	μ A78L08AC	μ A78L08C
9 V	μ A78L09AC	μ A78L09C
10 V	μ A78L10AC	μ A78L10C
12 V	μ A78L12AC	μ A78L12C
15 V	μ A78L15AC	μ A78L15C

description

This series of fixed-voltage monolithic integrated-circuit voltage regulators is designed for a wide range of applications. These applications include on-card regulation for elimination of noise and distribution problems associated with single-point regulation. In addition, they can be used with power-pass elements to make high-current voltage regulators. One of these regulators can deliver up to 100 mA of output current. The internal current limiting and thermal shutdown features of these regulators make them essentially immune to overload. When used as a replacement for a Zener-diode-resistor combination, an effective improvement in output impedance of typically two orders of magnitude can be obtained together with lower bias current.

schematic

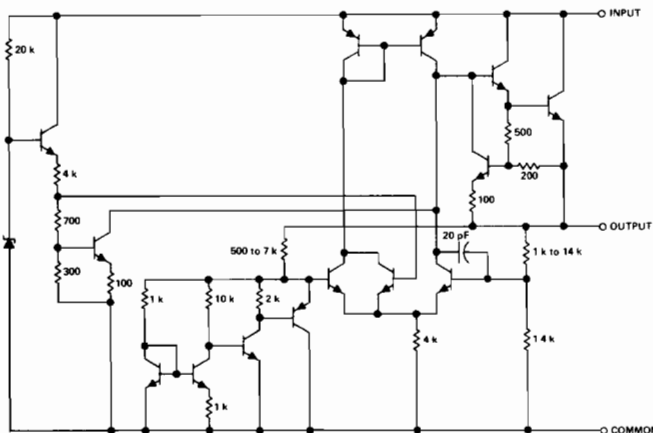

Resistor values shown are nominal and in ohms.

† Trademark of Texas Instruments

JG
DUAL-IN-LINE PACKAGE

LP
SILECT[†] PACKAGE

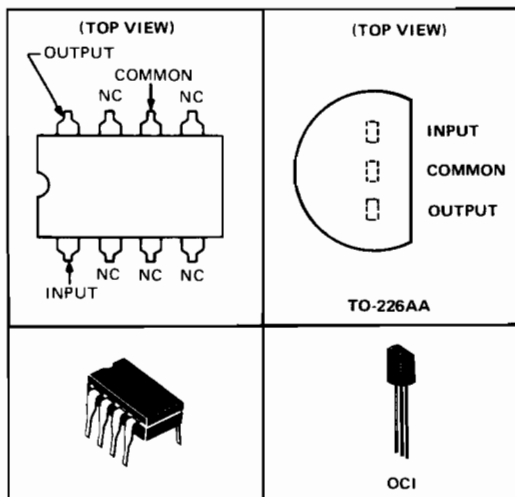

NC — No internal connection

Copyright © 1977 by Texas Instruments Incorporated

TEXAS INSTRUMENTS
INCORPORATED
POST OFFICE BOX 5012 • DALLAS, TEXAS 75222

SERIES μ A78L00

POSITIVE-VOLTAGE REGULATORS

absolute maximum ratings over operating temperature range (unless otherwise noted)

	μ A78L02AC, μ A78L02C THRU μ A78L10AC, μ A78L10C	μ A78L12AC, μ A78L12C μ A78L15AC, μ A78L15C	UNIT
Input voltage	30	35	V
Continuous total dissipation at 25°C free-air temperature (see Note 1)	JG package	825	mW
	LP package	775	
Continuous total dissipation at (or below) 25°C case temperature (see Note 1)	1600	1600	mW
Operating free-air, case, or virtual junction temperature range	0 to 150	0 to 150	°C
Storage temperature range	-65 to 150	-65 to 150	°C
Lead temperature 1/16 inch from case for 10 seconds	260	260	°C

NOTE 1: For operation above 25°C free-air or case temperature, refer to Dissipation Derating Curves, Figure 1 and Figure 2.

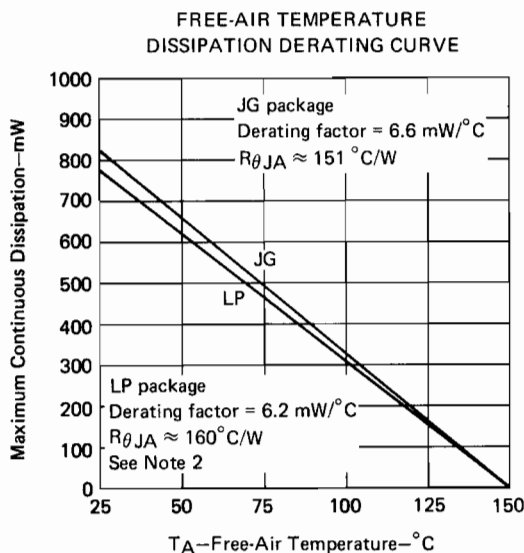

FIGURE 1

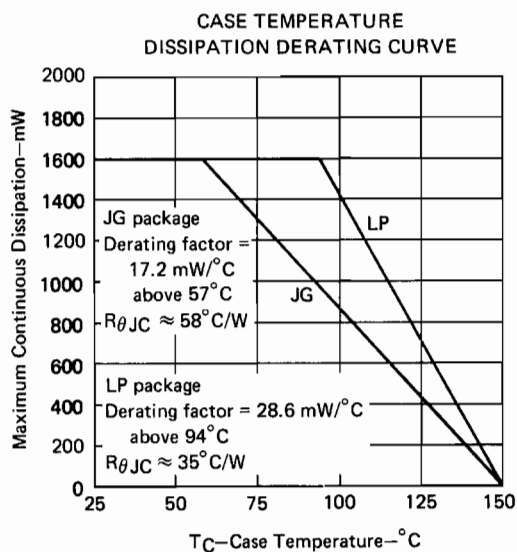

FIGURE 2

NOTE 2: This curve for the LP package is based on thermal resistance, $R_{\theta JA}$, measured in still air with the device mounted in an Augat socket. The bottom of the package was 3/8 inch above the socket.

recommended operating conditions

		MIN	MAX	UNIT
Input voltage, V_I	μ A78L02C, μ A78L02AC	4.75	20	V
	μ A78L05C, μ A78L05AC	7	20	
	μ A78L06C, μ A78L06AC	8.5	20	
	μ A78L08C, μ A78L08AC	10.5	23	
	μ A78L09C, μ A78L09AC	11.5	24	
	μ A78L10C, μ A78L10AC	12.5	25	
	μ A78L12C, μ A78L12AC	14.5	27	
	μ A78L15C, μ A78L15AC	17.5	30	
Output current, I_O			100	mA
Operating virtual junction temperature, T_J		0	125	°C

SERIES μ A78L00 POSITIVE-VOLTAGE REGULATORS

μ A78L02AC, μ A78L02C electrical characteristics at specified virtual junction temperature,
 $V_I = 9\text{ V}$, $I_O = 40\text{ mA}$ (unless otherwise noted)

PARAMETER	TEST CONDITIONS†		μ A78L02AC			μ A78L02C			UNIT
			MIN	TYP	MAX	MIN	TYP	MAX	
Output voltage	$V_I = 4.75\text{ V to }20\text{ V}$, $I_O = 1\text{ mA to }70\text{ mA}$	25°C	2.5	2.6	2.7	2.4	2.6	2.8	V
		0°C to 125°C	2.45	2.75		2.35	2.85		
			2.45	2.75		2.35	2.85		
Input regulation	$V_I = 4.75\text{ V to }20\text{ V}$ $V_I = 5\text{ V to }20\text{ V}$	25°C	20		100		20	125	mV
			16		75		16	100	
Ripple rejection	$V_I = 6\text{ V to }16\text{ V}$, $f = 120\text{ Hz}$	25°C	43	51		42	51		dB
Output regulation	$I_O = 1\text{ mA to }100\text{ mA}$ $I_O = 1\text{ mA to }40\text{ mA}$	25°C	12		50		12	50	mV
			6		25		6	25	
Output noise voltage	$f = 10\text{ Hz to }100\text{ kHz}$	25°C	30			30			μ V
Dropout voltage		25°C	1.7			1.7			V
Bias current		25°C	3.6		6		3.6	6	mA
		125°C			5.5		5.5		
Bias current change	$V_I = 5\text{ V to }20\text{ V}$ $I_O = 1\text{ mA to }40\text{ mA}$	0°C to 125°C			2.5		2.5		mA
					0.1		0.2		

μ A78L05AC, μ A78L05C electrical characteristics at specified virtual junction temperature,
 $V_I = 10\text{ V}$, $I_O = 40\text{ mA}$ (unless otherwise noted)

PARAMETER	TEST CONDITIONS†		μ A78L05AC			μ A78L05C			UNIT
			MIN	TYP	MAX	MIN	TYP	MAX	
Output voltage	$V_I = 7\text{ V to }20\text{ V}$, $I_O = 1\text{ mA to }40\text{ mA}$	25°C	4.8	5	5.2	4.6	5	5.4	V
		0°C to 125°C	4.75	5.25		4.5	5.5		
			4.75	5.25		4.5	5.5		
Input regulation	$V_I = 7\text{ V to }20\text{ V}$ $V_I = 8\text{ V to }20\text{ V}$	25°C	32		150		32	200	mV
			26		100		26	150	
Ripple rejection	$V_I = 8\text{ V to }18\text{ V}$, $f = 120\text{ Hz}$	25°C	41	49		40	49		dB
Output regulation	$I_O = 1\text{ mA to }100\text{ mA}$ $I_O = 1\text{ mA to }40\text{ mA}$	25°C	15		60		15	60	mV
			8		30		8	30	
Output noise voltage	$f = 10\text{ Hz to }100\text{ kHz}$	25°C	42			42			μ V
Dropout voltage		25°C	1.7			1.7			V
Bias current		25°C	3.8		6		3.8	6	mA
		125°C			5.5		5.5		
Bias current change	$V_I = 8\text{ V to }20\text{ V}$ $I_O = 1\text{ mA to }40\text{ mA}$	0°C to 125°C			1.5		1.5		mA
					0.1		0.2		

† All characteristics are measured with a capacitor across the input of 0.33 μ F and a capacitor across the output of 0.1 μ F. All characteristics except noise voltage and ripple rejection ratio are measured using pulse techniques ($t_w \leq 10\text{ ms}$, duty cycle $\leq 5\%$). Output voltage changes due to changes in internal temperature must be taken into account separately.

SERIES μ A78L00

POSITIVE-VOLTAGE REGULATORS

μ A78L06AC, μ A78L06C electrical characteristics at specified virtual junction temperature,
 $V_I = 12\text{ V}$, $I_O = 40\text{ mA}$ (unless otherwise noted)

PARAMETER	TEST CONDITIONS†		μ A78L06AC			μ A78L06C			UNIT
			MIN	TYP	MAX	MIN	TYP	MAX	
Output voltage	$V_I = 8.5\text{ V to }20\text{ V}$, $I_O = 1\text{ mA to }40\text{ mA}$	25°C	5.95	6.2	6.45	5.7	6.2	6.7	V
		0°C to 125°C	5.9		6.5	5.6		6.8	
			5.9		6.5	5.6		6.8	
Input regulation	$V_I = 8.5\text{ V to }20\text{ V}$	25°C		35	175		35	200	mV
	$V_I = 9\text{ V to }20\text{ V}$			29	125		29	150	
Ripple rejection	$V_I = 10\text{ V to }20\text{ V}$, $f = 120\text{ Hz}$	25°C	40	48		39	48		dB
Output regulation	$I_O = 1\text{ mA to }100\text{ mA}$	25°C		16	80		16	80	mV
	$I_O = 1\text{ mA to }40\text{ mA}$			9	40		9	40	
Output noise voltage	$f = 10\text{ Hz to }100\text{ kHz}$	25°C		46		46			μ V
Dropout voltage		25°C		1.7		1.7			V
Bias current		25°C		3.9	6		3.9	6	mA
		125°C			5.5			5.5	
Bias current change	$V_I = 9\text{ V to }20\text{ V}$	0°C to 125°C			1.5			1.5	mA
	$I_O = 1\text{ mA to }40\text{ mA}$				0.1			0.2	

μ A78L08AC, μ A78L08C electrical characteristics at specified virtual junction temperature,
 $V_I = 14\text{ V}$, $I_O = 40\text{ mA}$ (unless otherwise noted)

PARAMETER	TEST CONDITIONS†		μ A78L08AC			μ A78L08C			UNIT
			MIN	TYP	MAX	MIN	TYP	MAX	
Output voltage	$V_I = 10.5\text{ V to }23\text{ V}$, $I_O = 1\text{ mA to }40\text{ mA}$	25°C	7.7	8	8.3	7.36	8	8.64	V
		0°C to 125°C	7.6		8.4	7.2		8.8	
			7.6		8.4	7.2		8.8	
Input regulation	$V_I = 10.5\text{ V to }23\text{ V}$	25°C		42	175		42	200	mV
	$V_I = 11\text{ V to }23\text{ V}$			36	125		36	150	
Ripple rejection	$V_I = 13\text{ V to }23\text{ V}$, $f = 120\text{ Hz}$	25°C	37	46		36	46		dB
Output regulation	$I_O = 1\text{ mA to }100\text{ mA}$	25°C		18	80		18	80	mV
	$I_O = 1\text{ mA to }40\text{ mA}$			10	40		10	40	
Output noise voltage	$f = 10\text{ Hz to }100\text{ kHz}$	25°C		54		54			μ V
Dropout voltage		25°C		1.7		1.7			V
Bias current		25°C		4	6		4	6	mA
		125°C			5.5			5.5	
Bias current change	$V_I = 11\text{ V to }23\text{ V}$	0°C to 125°C			1.5			1.5	mA
	$I_O = 1\text{ mA to }40\text{ mA}$				0.1			0.2	

†All characteristics are measured with a capacitor across the input of 0.33 μ F and a capacitor across the output of 0.1 μ F. All characteristics except noise voltage and ripple rejection ratio are measured using pulse techniques ($t_w \leq 10\text{ ms}$, duty cycle $\leq 5\%$). Output voltage changes due to changes in internal temperature must be taken into account separately.

SERIES μ A78L00 POSITIVE-VOLTAGE REGULATORS

μ A78L09AC, μ A78L09C electrical characteristics at specified virtual junction temperature,
 $V_I = 16$ V, $I_O = 40$ mA (unless otherwise noted)

PARAMETER	TEST CONDITIONS [†]	μ A78L09AC			μ A78L09C			UNIT	
		MIN	TYP	MAX	MIN	TYP	MAX		
Output voltage	$V_I = 12$ V to 24 V, $I_O = 1$ mA to 40 mA $I_O = 1$ mA to 70 mA	25°C	8.6	9	9.4	8.3	9	9.7	V
		0°C to 125°C	8.55	9.45		8.1	9.9		
		8.55	9.45		8.1	9.9			
Input regulation	$V_I = 12$ V to 24 V	25°C	45	175		45	225	mV	
	$V_I = 13$ V to 24 V		40	125		40	175		
Ripple rejection	$V_I = 13$ V to 24 V, $f = 120$ Hz	25°C	37	45		36	45	dB	
Output regulation	$I_O = 1$ mA to 100 mA	25°C	19	90		19	90	mV	
	$I_O = 1$ mA to 40 mA		11	40		11	40		
Output noise voltage	$f = 10$ Hz to 100 kHz	25°C	58			58		μ V	
Dropout voltage		25°C	1.7			1.7		V	
Bias current		25°C	4.1	6		4.1	6	mA	
		125°C		5.5			5.5		
Bias current change	$V_I = 13$ V to 24 V	0°C to 125°C		1.5			1.5	mA	
	$I_O = 1$ mA to 40 mA			0.1			0.2		

μ A78L10AC, μ A78L10C electrical characteristics at specified virtual junction temperature,
 $V_I = 17$ V, $I_O = 40$ mA (unless otherwise noted)

PARAMETER	TEST CONDITIONS [†]	μ A78L10AC			μ A78L10C			UNIT	
		MIN	TYP	MAX	MIN	TYP	MAX		
Output voltage	$V_I = 13$ V to 25 V, $I_O = 1$ mA to 40 mA $I_O = 1$ mA to 70 mA	25°C	9.6	10	10.4	9.2	10	10.8	V
		0°C to 125°C	9.5	10.5		9	10		
		9.5	10.5		9	10			
Input regulation	$V_I = 13$ V to 25 V	25°C	51	175		51	225	mV	
	$V_I = 14$ V to 25 V		42	125		42	175		
Ripple rejection	$V_I = 14$ V to 25 V, $f = 120$ Hz	25°C	37	44		36	44	dB	
Output regulation	$I_O = 1$ mA to 100 mA	25°C	20	90		20	90	mV	
	$I_O = 1$ mA to 40 mA		11	40		11	40		
Output noise voltage	$f = 10$ Hz to 100 kHz	25°C	62			62		μ V	
Dropout voltage		25°C	1.7			1.7		V	
Bias current		25°C	4.2	6		4.2	6	mA	
		125°C		5.5			5.5		
Bias current change	$V_I = 14$ V to 25 V	0°C to 125°C		1.5			1.5	mA	
	$I_O = 1$ mA to 40 mA			0.1			0.2		

[†]All characteristics are measured with a capacitor across the input of 0.33 μ F and a capacitor across the output of 0.1 μ F. All characteristics except noise voltage and ripple rejection ratio are measured using pulse techniques ($t_w \leq 10$ ms, duty cycle $\leq 5\%$). Output voltage changes due to changes in internal temperature must be taken into account separately.

SERIES μ A78L00 POSITIVE-VOLTAGE REGULATORS

μ A78L12AC, μ A78L12C electrical characteristics at specified virtual junction temperature,
 $V_I = 19$ V, $I_O = 40$ mA (unless otherwise noted)

PARAMETER	TEST CONDITIONS†		μ A78L12AC			μ A78L12C			UNIT
			MIN	TYP	MAX	MIN	TYP	MAX	
Output voltage	$V_I = 14.5$ V to 27 V, $I_O = 1$ mA to 40 mA $I_O = 1$ mA to 70 mA	25°C	11.5	12	12.5	11.1	12	12.9	V
		0°C to 125°C	11.4		12.6	10.8		13.2	
			11.4		12.6	10.8		13.2	
Input regulation	$V_I = 14.5$ V to 27 V $V_I = 16$ V to 27 V	25°C		55	250		55	250	mV
				49	200		49	200	
Ripple rejection	$V_I = 15$ V to 25 V, $f = 120$ Hz	25°C	37	42		36	42	dB	
Output regulation	$I_O = 1$ mA to 100 mA $I_O = 1$ mA to 40 mA	25°C		22	100		22	100	mV
				13	50		13	50	
Output noise voltage	$f = 10$ Hz to 100 kHz	25°C		70		70		μ V	
Dropout voltage		25°C		1.7		1.7		V	
Bias current		25°C		4.3	6.5		4.3	6.5	mA
		125°C			6			6	
Bias current change	$V_I = 16$ V to 27 V $I_O = 1$ mA to 40 mA	0°C to 125°C			1.5			1.5	mA
					0.1			0.2	

μ A78L15AC, μ A78L15C electrical characteristics at specified virtual junction temperature,
 $V_I = 23$ V, $I_O = 40$ mA (unless otherwise noted)

PARAMETER	TEST CONDITIONS†		μ A78L15AC			μ A78L15C			UNIT
			MIN	TYP	MAX	MIN	TYP	MAX	
Output voltage	$V_I = 17.5$ V to 30 V, $I_O = 1$ mA to 40 mA $I_O = 1$ mA to 70 mA	25°C	14.4	15	15.6	13.8	15	16.2	V
		0°C to 125°C	14.25		15.75	13.5		16.5	
			14.25		15.75	13.5		16.5	
Input regulation	$V_I = 17.5$ V to 30 V $V_I = 20$ V to 30 V	25°C		65	300		65	300	mV
				58	250		58	250	
Ripple rejection	$V_I = 18.5$ V to 28.5 V, $f = 120$ Hz	25°C	34	39		33	39	dB	
Output regulation	$I_O = 1$ mA to 100 mA $I_O = 1$ mA to 40 mA	25°C		25	150		25	150	mV
				15	75		15	75	
Output noise voltage	$f = 10$ Hz to 100 kHz	25°C		82		82		μ V	
Dropout voltage		25°C		1.7		1.7		V	
Bias current		25°C		4.6	6.5		4.6	6.5	mA
		125°C			6			6	
Bias current change	$V_I = 20$ V to 30 V $I_O = 1$ mA to 40 mA	0°C to 125°C			1.5			1.5	mA
					0.1			0.2	

† All characteristics are measured with a capacitor across the input of 0.33 μ F and a capacitor across the output of 0.1 μ F. All characteristics except noise voltage and ripple rejection ratio are measured using pulse techniques ($t_w \leq 10$ ms, duty cycle $\leq 5\%$). Output voltage changes due to changes in internal temperature must be taken into account separately.

LINEAR INTEGRATED CIRCUITS

SERIES μ A78M00 POSITIVE-VOLTAGE REGULATORS

BULLETIN NO. DL-S 12403, JUNE 1976—REVISED SEPTEMBER 1977

- 3-Terminal Regulators
- Output Current up to 500 mA
- No external components
- Internal Thermal Overload Protection
- Direct Replacements for Fairchild μ A78M00 Series and National LM341 Series
- High Power Dissipation Capability
- Internal Short-Circuit Current Limiting
- Output Transistor Safe-Area Compensation

NOMINAL OUTPUT VOLTAGE	-55°C TO 150°C OPERATING TEMPERATURE RANGE	0°C TO 125°C OPERATING TEMPERATURE RANGE
5 V	μ A78M05M	μ A78M05C
6 V	μ A78M06M	μ A78M06C
8 V	μ A78M08M	μ A78M08C
12 V	μ A78M12M	μ A78M12C
15 V	μ A78M15M	μ A78M15C
20 V	μ A78M20M	μ A78M20C
22 V	μ A78M22M	μ A78M22C
24 V	μ A78M24M	μ A78M24C
PACKAGES	LA	KC, KD, and LA

description

This series of fixed-voltage monolithic integrated-circuit voltage regulators is designed for a wide range of applications. These applications include on-card regulation for elimination of noise and distribution problems associated with single-point regulation. One of these regulators can deliver up to 500 milliamperes of output current. The internal current limiting and thermal shutdown features of these regulators make them essentially immune to overload. In addition to use as fixed-voltage regulators, these devices can be used with external components to obtain adjustable output voltages and currents and also as the power pass element in precision regulators.

schematic

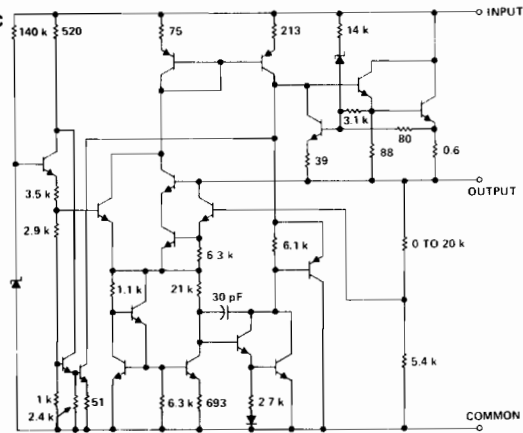

Resistor values shown are nominal and in ohms.

terminal assignments

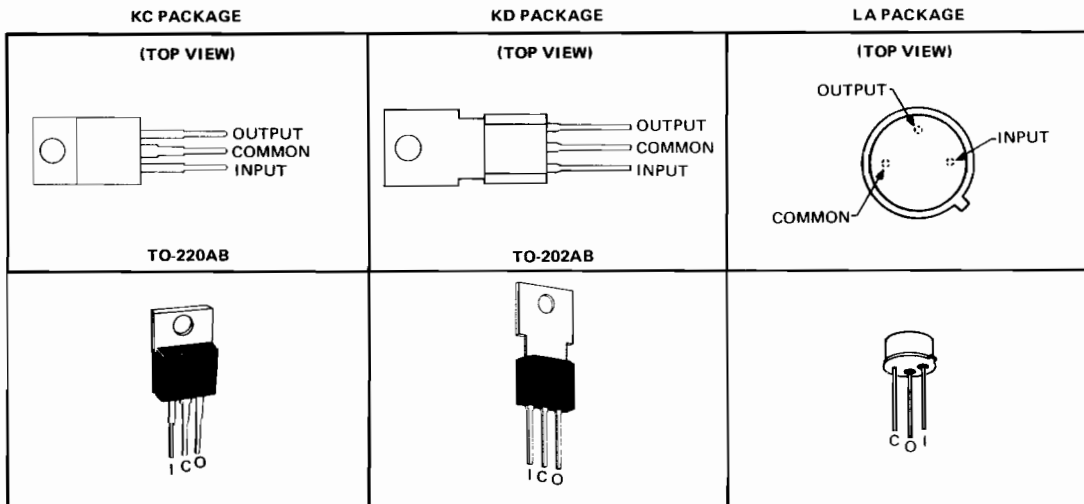

Copyright © 1977 by Texas Instruments Incorporated

SERIES μ A78M00

POSITIVE-VOLTAGE REGULATORS

absolute maximum ratings over operating temperature range (unless otherwise noted)

		μ A78M05M THRU μ A78M24M	μ A78M05C THRU μ A78M24C	UNIT
Input voltage	μ A78M20 thru μ A78M24	40	40	V
	All others	35	35	
Continuous total dissipation at 25°C free-air temperature (see Note 1)	KC (TO-220AB) package	2	2	W
	KD(TO-202AB) package	1.5	1.5	
	LA package	0.6	0.6	
Continuous total dissipation at (or below) 25°C case temperature (see Note 1)	KC and KD packages	7.5	7.5	W
	LA package	5	5	
Operating free-air, case, or virtual junction temperature range		-55 to 150	0 to 150	°C
Storage temperature range		-65 to 150	-65 to 150	°C
Lead temperature 1/16 inch from case for 10 seconds		KC and KD packages		260
Lead temperature 1/16 inch from case for 60 seconds		LA package		300

NOTE 1: For operation above 25°C free air or case temperature, refer to Dissipation Derating Curves, Figures 1 through 4, page 188.

recommended operating conditions

		MIN	MAX	UNIT
Input voltage, V_I	μ A78M05M, μ A78M05C	7	25	V
	μ A78M06M, μ A78M06C	8	25	
	μ A78M08M, μ A78M08C	10.5	25	
	μ A78M12M, μ A78M12C	14.5	30	
	μ A78M15M, μ A78M15C	17.5	30	
	μ A78M20M, μ A78M20C	23	35	
	μ A78M22M, μ A78M22C	24	38	
Output current, I_O		500		mA
Operating virtual junction temperature, T_J	μ A78M05M thru μ A78M24M	-55	150	°C
	μ A78M05C thru μ A78M24C	0	125	

TYPES μ A78M05M, μ A78M05C POSITIVE-VOLTAGE REGULATORS

μ A78M05M, μ A78M05C electrical characteristics at specified virtual junction temperature,
 $V_I = 10$ V, $I_O = 350$ mA (unless otherwise noted)

PARAMETER	TEST CONDITIONS†	μ A78M05M			μ A78M05C			UNIT
		MIN	TYP	MAX	MIN	TYP	MAX	
Output voltage	$I_O = 5$ mA to 350 mA	25°C						V
		-55°C to 150°C						
		0°C to 125°C						
Input regulation	$I_O = 200$ mA	25°C						mV
		$V_I = 8$ V to 20 V						
		$V_I = 7$ V to 20 V						
		$V_I = 8$ V to 25 V						
Ripple rejection	$V_I = 8$ V to 18 V, $f = 120$ Hz	25°C						dB
		$I_O = 100$ mA						
		$I_O = 300$ mA						
Output regulation	$I_O = 5$ mA to 500 mA $I_O = 5$ mA to 200 mA	25°C						mV
		$I_O = 5$ mA						
Temperature coefficient of output voltage	$I_O = 5$ mA	-1						mV/°C
Output noise voltage	$f = 10$ Hz to 100 kHz	40						μ V
Dropout voltage		25°C						V
		25°C						
Bias current		25°C						mA
		-55°C to 150°C						
		0°C to 125°C						
Bias current change	$I_O = 200$ mA, $V_I = 8$ V to 25 V	0.8						mA
		0.5						
		0.5						
Short-circuit output current	$V_I = 35$ V	300						mA
Peak output current		700						A

† All characteristics are measured with a capacitor across the input of 0.33 μ F and a capacitor across the output of 0.1 μ F. All characteristics except noise voltage and ripple rejection ratio are measured using pulse techniques ($t_{pw} \leq 10$ ms, duty cycle $\leq 5\%$). Output voltage changes due to changes in internal temperature must be taken into account separately.

TYPES μ A78M06M, μ A78M06C

POSITIVE-VOLTAGE REGULATORS

μ A78M06M, μ A78M06C electrical characteristics at specified virtual junction temperature, $V_I = 11$ V, $I_O = 350$ mA (unless otherwise noted)

PARAMETER	TEST CONDITIONS†	μ A78M06M			μ A78M06C			UNIT			
		MIN	TYP	MAX	MIN	TYP	MAX				
Output voltage	$I_O = 5$ mA to 350 mA	25°C		5.75	6	6.25	5.75	6	6.25	V	
		-55°C to 150°C		5.7		6.3					
		0°C to 125°C			5.7			5.7			6.3
Input regulation	$I_O = 200$ mA	25°C			5	60		5	100	mV	
		-55°C to 150°C			1.5	30					
		0°C to 125°C									
		25°C						1.5	50		
Ripple rejection	$V_I = 9$ V to 19 V, $f = 120$ Hz	-55°C to 150°C		59						dB	
		0°C to 125°C		59	80	60	59	80			
		25°C		59	20	60	59	20	120		
Output regulation	$I_O = 5$ mA to 500 mA	25°C			10	30		10	60	mV	
		-55°C to 150°C			-0.5						
Temperature coefficient of output voltage	$I_O = 5$ mA	-55°C to 150°C						-0.5		mV/°C	
		0°C to 125°C									
Output noise voltage	$f = 10$ Hz to 100 kHz	25°C			45			45		μ V	
		-55°C to 150°C			2			2			
Dropout voltage		25°C			2			2		V	
		-55°C to 150°C			4.5	6		4.5	6		
Bias current	$I_O = 200$ mA, $V_I = 9$ V to 25 V	-55°C to 150°C				0.8				mA	
		0°C to 125°C						0.8			
		25°C									
Bias current change	$I_O = 5$ mA to 350 mA	-55°C to 150°C				0.5				mA	
		0°C to 125°C						0.5			
		25°C									
Short-circuit output current	$V_I = 35$ V	25°C			270			270		mA	
		-55°C to 150°C			700			700			
Peak output current		25°C								A	

† All characteristics are measured with a capacitor across the input of 0.33 μ F and a capacitor across the output of 0.1 μ F. All characteristics except noise voltage and ripple rejection ratio are measured using pulse techniques ($t_{PW} \leq 10$ ms, duty cycle $\leq 5\%$). Output voltage changes due to changes in internal temperature must be taken into account separately.

TYPES μ A78M08M, μ A78M08C POSITIVE-VOLTAGE REGULATORS

μ A78M08M, μ A78M08C electrical characteristics at specified virtual junction temperature,
 $V_I = 14$ V, $I_O = 350$ mA (unless otherwise noted)

PARAMETER	TEST CONDITIONS†		μ A78M08M			μ A78M08C			UNIT
			MIN	TYP	MAX	MIN	TYP	MAX	
Output voltage	$I_O = 5$ mA to 350 mA	$V_I = 11.5$ V to 23 V	7.7	8	8.3	7.7	8	8.3	V
		-55° C to 150° C	7.6		8.4				
		0° C to 125° C				7.6	6	100	
Input regulation	$I_O = 200$ mA	$V_I = 10.5$ V to 25 V		6	60		6	100	mV
		$V_I = 11$ V to 20 V		2	30		2	50	
		$V_I = 11$ V to 25 V							
Ripple rejection	$V_I = 11.5$ V to 21.5 V, $f = 120$ Hz	$I_O = 100$ mA	56			56			dB
		$I_O = 300$ mA	56	80		56	80		
Output regulation	$I_O = 5$ mA to 500 mA $I_O = 5$ mA to 200 mA	25° C		25	80		25	160	mV
		-55° C to 150° C		10	40		10	80	
Temperature coefficient of output voltage	$I_O = 5$ mA	0° C to 125° C							mV/ $^\circ$ C
		-55° C to 150° C		-0.5			-0.5		
Output noise voltage	$f = 10$ Hz to 100 kHz	25° C		52			52		μ V
		25° C		2			2		
Dropout voltage		25° C		4.6	6		4.6	6	mA
		-55° C to 150° C			0.8				
Bias current change	$I_O = 200$ mA	0° C to 125° C						0.8	mA
		-55° C to 150° C			0.5				
		0° C to 125° C						0.5	
Short-circuit output current	$V_I = 35$ V	25° C		250			250		mA
Peak output current		25° C		700			700		A

† All characteristics are measured with a capacitor across the input of 0.33 μ F and a capacitor across the output of 0.1 μ F. All characteristics except noise voltage and ripple rejection ratio are measured using pulse techniques ($t_w \leq 10$ ms, duty cycle $\leq 5\%$). Output voltage changes due to changes in internal temperature must be taken into account separately.

TYPES μ A78M12M, μ A78M12C

POSITIVE-VOLTAGE REGULATORS

μ A78M12M, μ A78M12C electrical characteristics at specified virtual junction temperature,
 $V_I = 19$ V, $I_O = 350$ mA (unless otherwise noted)

PARAMETER	TEST CONDITIONS†	μ A78M12M			μ A78M12C			UNIT		
		MIN	TYP	MAX	MIN	TYP	MAX			
Output voltage	$I_O = 5$ mA to 350 mA	25°C		11.5	12	12.5	11.5	12	12.5	V
		-55°C to 150°C		11.4		12.6	11.4		12.6	
Input regulation	$I_O = 200$ mA	25°C			8	60		8	100	mV
		-55°C to 150°C								
		0°C to 125°C			2	30		2	50	
		0°C to 125°C								
Ripple rejection	$V_I = 15$ V to 25 V, $f = 120$ Hz	-55°C to 150°C		55			55			dB
		0°C to 125°C		55	80		55	80		
Output regulation	$I_O = 5$ mA to 500 mA	25°C		55	80		55	80		mV
		-55°C to 150°C		55	25	120	55	25	240	
Temperature coefficient of output voltage	$I_O = 5$ mA to 200 mA	25°C			10	60		10	120	mV/°C
		-55°C to 150°C			-1			-1		
Output noise voltage	$f = 10$ Hz to 100 kHz	25°C			75			75		μ V
		-55°C to 150°C								
Dropout voltage	$I_O = 5$ mA	25°C			2			2		V
		-55°C to 150°C								
Bias current	$I_O = 5$ mA to 350 mA	25°C			4.8	6		4.8	6	mA
		-55°C to 150°C								
Bias current change	$I_O = 200$ mA	25°C				0.8			0.8	mA
		-55°C to 150°C								
Short-circuit output current	$V_I = 35$ V	25°C			240			240		mA
		-55°C to 150°C								
Peak output current		25°C			700			700		A

† All characteristics are measured with a capacitor across the input of 0.33 μ F and a capacitor across the output of 0.1 μ F. All characteristics except noise voltage and ripple rejection ratio are measured using pulse techniques ($t_w \leq 10$ ms, duty cycle $\leq 5\%$). Output voltage changes due to changes in internal temperature must be taken into account separately.

TYPES μ A78M15M, μ A78M15C POSITIVE-VOLTAGE REGULATORS

μ A78M15M, μ A78M15C electrical characteristics at specified virtual junction temperature,
 $V_I = 23$ V, $I_O = 350$ mA (unless otherwise noted)

PARAMETER	TEST CONDITIONS†	μ A78M15M			μ A78M15C			UNIT		
		MIN	TYP	MAX	MIN	TYP	MAX			
Output voltage	$I_O = 5$ mA to 350 mA	25°C		14.4	15	15.6	14.4	15	15.6	V
		-55°C to 150°C		14.25		15.75				
		0°C to 125°C					14.25		15.75	
Input regulation	$V_I = 17.5$ V to 30 V $V_I = 20$ V to 30 V	25°C		10	60		10	100	mV	
				3	30		3	50		
Ripple rejection	$V_I = 18.5$ V to 28.5 V, $f = 120$ Hz	-55°C to 150°C		54			54		dB	
		0°C to 125°C								
		25°C		54	70		54	70		
Output regulation	$I_O = 5$ mA to 500 mA $I_O = 5$ mA to 200 mA	25°C		25	150		25	300	mV	
				10	75		10	150		
Temperature coefficient of output voltage	$I_O = 5$ mA	-55°C to 150°C		-1			-1		mV/°C	
		0°C to 125°C								
Output noise voltage	$f = 10$ Hz to 100 kHz	25°C		90			90		μ V	
Dropout voltage		25°C		2			2		V	
				4.8	6		4.8	6		
Bias current	$V_I = 18.5$ V to 30 V $V_I = 17.5$ V to 30 V	-55°C to 150°C		0.8			0.8		mA	
		0°C to 125°C								
Bias current change	$I_O = 5$ mA to 350 mA	-55°C to 150°C				0.5			mA	
		0°C to 125°C						0.5		
Short-circuit output current	$V_I = 35$ V	25°C		240			240		mA	
Peak output current		25°C		700			700		A	

† All characteristics are measured with a capacitor across the input of 0.33 μ F and a capacitor across the output of 0.1 μ F. All characteristics except noise voltage and ripple rejection ratio are measured using pulse techniques ($t_w \leq 10$ ms, duty cycle $\leq 5\%$). Output voltage changes due to changes in internal temperature must be taken into account separately.

TYPES μ A78M20M, μ A78M20C

POSITIVE-VOLTAGE REGULATORS

μ A78M20M, μ A78M20C electrical characteristics at specified virtual junction temperature,
 $V_I = 29$ V, $I_O = 350$ mA (unless otherwise noted)

PARAMETER	TEST CONDITIONS†	μ A78M20M			μ A78M20C			UNIT
		MIN	TYP	MAX	MIN	TYP	MAX	
Output voltage	$I_O = 5$ mA to 350 mA	25°C						V
		19.2	20	20.8	19.2	20	20.8	
Input regulation	$V_I = 24$ V to 35 V	-55°C to 150°C						mV
	$V_I = 23$ V to 35 V	0°C to 125°C						
	$V_I = 24$ V to 35 V	19			19			
Ripple rejection	$I_O = 200$ mA	25°C						dB
		$V_I = 23$ V to 35 V	10	60	10	100		
		$V_I = 24$ V to 35 V	5	30	5	50		
Output regulation	$V_I = 24$ V to 34 V, $f = 120$ Hz	-55°C to 150°C						mV
		53			53			
Temperature coefficient of output voltage	$I_O = 100$ mA	25°C						mV/°C
		53	70		53	70		
Dropout voltage	$I_O = 5$ mA to 500 mA	25°C						mV
		30	200		30	400		
Bias current	$I_O = 5$ mA to 200 mA	-55°C to 150°C						mA
		-1.1			-1.1			
Short-circuit output current	$I_O = 5$ mA	25°C						mA
		110			110			
Peak output current	$f = 10$ Hz to 100 kHz	25°C						A
		2			2			
Bias current change	$I_O = 5$ mA to 350 mA	25°C						mA
		4.9	6		4.9	6		
Short-circuit output current	$V_I = 24$ V to 35 V	-55°C to 150°C						mA
		0.8			0.8			
Peak output current	$V_I = 23$ V to 35 V	0°C to 125°C						mA
		0.5			0.5			
Peak output current	$V_I = 35$ V	25°C						mA
		240			240			
Peak output current		25°C						A
		700			700			

† All characteristics are measured with a capacitor across the input of 0.33 μ F and a capacitor across the output of 0.1 μ F. All characteristics except noise voltage and ripple rejection ratio are measured using pulse techniques ($t_{pw} \leq 10$ ms, duty cycle $\leq 5\%$). Output voltage changes due to changes in internal temperature must be taken into account separately.

TYPES μ A78M22M, μ A78M22C POSITIVE-VOLTAGE REGULATORS

μ A78M22M, μ A78M22C electrical characteristics at specified virtual junction temperature,
 $V_I = 31$ V, $I_O = 350$ mA (unless otherwise noted)

PARAMETER	TEST CONDITIONS†		μ A78M22M			μ A78M22C			UNIT
			MIN	TYP	MAX	MIN	TYP	MAX	
Output voltage	$I_O = 5$ mA to 350 mA	$V_I = 26$ V to 36 V –55° C to 150° C	21.1	22	22.9	21.1	22	22.9	V
			20.9		23.1	20.9		23.1	
Input regulation	$I_O = 200$ mA	$V_I = 25$ V to 36 V $V_I = 26$ V to 34 V	10	60	60	10	100	100	mV
			5	30	30	5	50	50	
Ripple rejection	$V_I = 26$ V to 36 V, $f = 120$ Hz	$I_O = 100$ mA $I_O = 300$ mA	51			51			dB
			51	70		51	70		
Output regulation	$I_O = 5$ mA to 500 mA $I_O = 5$ mA to 200 mA	25° C	30	220	220	30	440	440	mV
			10	110	110	10	220	220	
Temperature coefficient of output voltage	$I_O = 5$ mA	–55° C to 150° C							mV/°C
Output noise voltage	$f = 10$ Hz to 100 kHz	25° C							μ V
			–1.1			–1.1			
Dropout voltage		25° C	160			160			V
			2			2			
Bias current		25° C	4.9	6	6	4.9	6	6	mA
Bias current change	$I_O = 200$ mA	–55° C to 150° C			0.8				mA
								0.8	
Short-circuit output current	$V_I = 25$ V to 36 V	–55° C to 150° C							mA
								0.5	
Peak output current	$V_I = 35$ V	25° C	240			240			A
			700			700			

† All characteristics are measured with a capacitor across the input of 0.33 μ F and a capacitor across the output of 0.1 μ F. All characteristics except noise voltage and ripple rejection ratio are measured using pulse techniques ($t_w \leq 10$ ms, duty cycle $\leq 5\%$). Output voltage changes due to changes in internal temperature must be taken into account separately.

TYPES μ A78M24M, μ A78M24C

POSITIVE-VOLTAGE REGULATORS

μ A78M24M, μ A78M24C electrical characteristics at specified virtual junction temperature,
 $V_I = 33$ V, $I_O = 350$ mA (unless otherwise noted)

PARAMETER	TEST CONDITIONS†						μ A78M24M			μ A78M24C			UNIT		
					MIN	TYP	MAX	MIN	TYP	MAX	MIN	TYP		MAX	
Output voltage	$I_O = 5$ mA to 350 mA			25°C	23	24	25	23	24	25	22.8	24.8	25.2	V	
															$V_I = 28$ V to 38 V
Input regulation	$I_O = 200$ mA		25°C		10	5	30	10	5	30	22.8	10	100	mV	
															$V_I = 27$ V to 38 V
Ripple rejection	$V_I = 28$ V to 38 V, $f = 120$ Hz		25°C		50			50				50	70	dB	
															$I_O = 100$ mA
Output regulation	$I_O = 5$ mA to 500 mA $I_O = 5$ mA to 200 mA		25°C		30	10	240	30	10	240	50	50	30	480	mV
Temperature coefficient of output voltage	$I_O = 5$ mA		25°C		-1.2			-1.2				-1.2		mV/°C	
															$V_I = 28$ V to 38 V
Output noise voltage	$f = 10$ Hz to 100 kHz		25°C		170			170				170		μ V	
															$V_I = 28$ V to 38 V
Dropout voltage			25°C		2			2				2		V	
															$V_I = 28$ V to 38 V
Bias current			25°C		5	6	0.8	5	6	0.8		5	6	mA	
															$V_I = 28$ V to 38 V
Bias current change	$I_O = 5$ mA to 350 mA		25°C		240			240				240		mA	
															$V_I = 28$ V to 38 V
Short-circuit output current	$V_I = 35$ V		25°C		700			700				700		mA	
															$V_I = 28$ V to 38 V
Peak output current			25°C		700			700				700		A	
															$V_I = 28$ V to 38 V

† All characteristics are measured with a capacitor across the input of 0.33 μ F and a capacitor across the output of 0.1 μ F. All characteristics except noise voltage and ripple rejection ratio are measured using pulse techniques ($t_w \leq 10$ ms, duty cycle $\leq 5\%$). Output voltage changes due to changes in internal temperature must be taken into account separately.

- 3-Terminal Regulators
- Output Current up to 1.5 A
- No External Components
- Internal Thermal Overload Protection
- Direct Replacements for Fairchild μ A7900 Series
- Essentially Equivalent to National LM320 Series
- High Power Dissipation Capability
- Internal Short-Circuit Current Limiting
- Output Transistor Safe-Area Compensation

NOMINAL OUTPUT VOLTAGE	REGULATOR
-5 V	μ A7905C
-5.2 V	μ A7952C
-6 V	μ A7906C
-8 V	μ A7908C
-12 V	μ A7912C
-15 V	μ A7915C
-18 V	μ A7918C
-24 V	μ A7924C

description

This series of fixed-negative-voltage monolithic integrated-circuit voltage regulators is designed to complement Series μ A7800 in a wide range of applications. These applications include on-card regulation for elimination of noise and distribution problems associated with single-point regulation. One of these regulators can deliver up to 1.5 amperes of output current. The internal current limiting and thermal shutdown features of these regulators make them essentially immune to overload. In addition to use as fixed-voltage regulators, these devices can be used with external components to obtain adjustable output voltages and currents and also as the power pass element in precision regulators.

KC PACKAGE

(TOP VIEW)

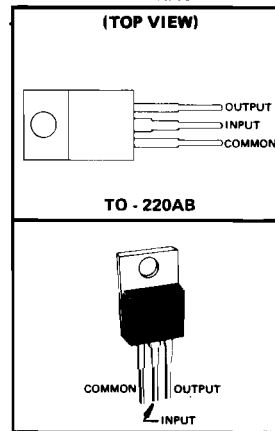

schematic

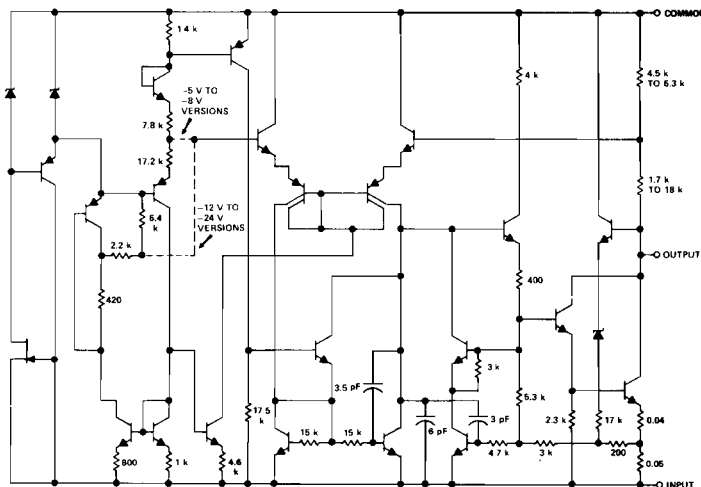

Resistor values shown are nominal and in ohms.

SERIES μ A7900 POSITIVE-VOLTAGE REGULATORS

absolute maximum ratings over operating temperature range (unless otherwise noted)

		μ A7905C THRU μ A7924C	UNIT
Input voltage	μ A7924C	-40	V
	All others	-35	
Continuous total dissipation at 25°C free-air temperature (see Note 1)		2	W
Continuous total dissipation at (or below) 25°C case temperature (see Note 1)		15	W
Operating free-air, case, or virtual junction temperature range		0 to 150	°C
Storage temperature range		-65 to 150	°C
Lead temperature 1/8 inch from case for 10 seconds		260	°C

NOTE 1: For operation above 25°C free-air or case temperature, refer to Dissipation Derating Curves, Figure 1 and Figure 2.

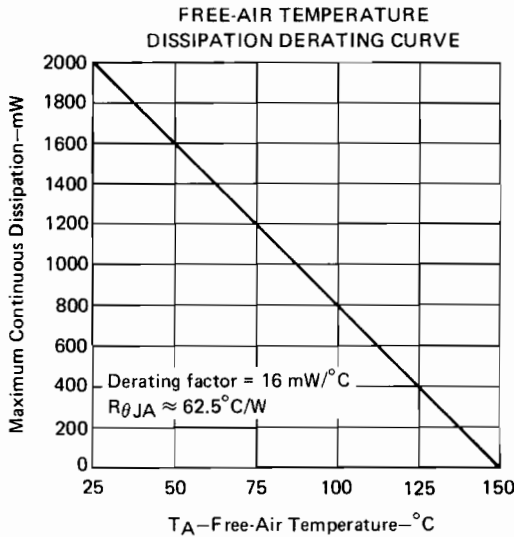

FIGURE 1

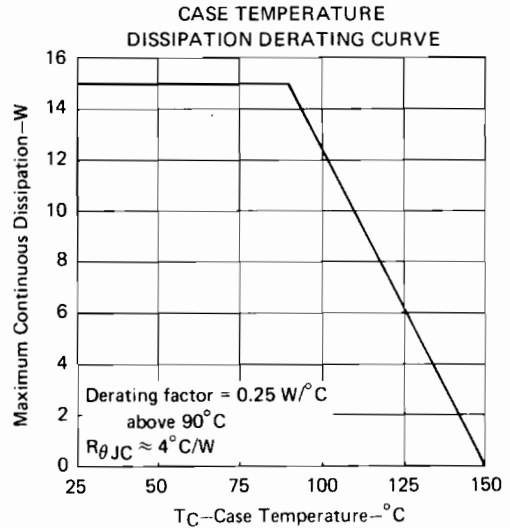

FIGURE 2

recommended operating conditions

		MIN	MAX	UNIT
Input voltage, V_I	μ A7905C	-7	-25	V
	μ A7952C	-7.2	-25	
	μ A7906C	-8	-25	
	μ A7908C	-10.5	-25	
	μ A7912C	-14.5	-30	
	μ A7915C	-17.5	-30	
	μ A7918C	-21	-33	
	μ A7924C	-27	-38	
Output current, I_O			1.5	A
Operating virtual junction temperature, T_J		0	125	°C

TYPES μ A7905C, μ A7952C NEGATIVE-VOLTAGE REGULATORS

μ A7905C electrical characteristics at specified virtual junction temperature,
 $V_I = -10$ V, $I_O = 500$ mA (unless otherwise noted)

PARAMETER	TEST CONDITIONS†		μ A7905C			UNIT	
			MIN	TYP	MAX		
Output voltage	$I_O = 5$ mA to 1 A, $P < 15$ W	$V_I = -7$ V to -20 V, 0° C to 125° C	-4.8	-5	-5.2	V	
		25° C	-4.75		-5.25		
Input regulation	$V_I = -7$ V to -25 V	25° C	3			mV	
	$V_I = -8$ V to -12 V		1				
Ripple rejection	$V_I = -8$ V to -18 V, $f = 120$ Hz	0° C to 125° C	54	60		dB	
Output regulation	$I_O = 5$ mA to 1.5 A	25° C	15			mV	
	$I_O = 250$ mA to 750 mA		5				
Temperature coefficient of output voltage	$I_O = 5$ mA	0° C to 125° C	-0.4			mV/ $^\circ$ C	
Output noise voltage	$f = 10$ Hz to 100 kHz	25° C	125			μ V	
Dropout voltage	$I_O = 1$ A	25° C	1.1			V	
Bias current		25° C	1			2	mA
Bias current change	$V_I = -7$ V to -25 V	0° C to 125° C				1.3	mA
	$I_O = 5$ mA to 1 A					0.5	
Peak output current		25° C	2.1			A	

μ A7952C electrical characteristics at specified virtual junction temperature,
 $V_I = -10$ V, $I_O = 500$ mA (unless otherwise noted)

PARAMETER	TEST CONDITIONS†		μ A7952C			UNIT	
			MIN	TYP	MAX		
Output voltage	$I_O = 5$ mA to 1 A, $P < 15$ W	$V_I = -7.2$ V to -20 V, 0° C to 125° C	-5	-5.2	-5.4	V	
		25° C	-4.95		-5.45		
Input regulation	$V_I = -7.2$ V to -25 V	25° C	3			mV	
	$V_I = -8.2$ V to -12 V		1				
Ripple rejection	$V_I = -8.2$ V to -18 V, $f = 120$ Hz	0° C to 125° C	54	60		dB	
Output regulation	$I_O = 5$ mA to 1.5 A	25° C	15			mV	
	$I_O = 250$ mA to 750 mA		5				
Temperature coefficient of output voltage	$I_O = 5$ mA	0° C to 125° C	-0.4			mV/ $^\circ$ C	
Output noise voltage	$f = 10$ Hz to 100 kHz	25° C	125			μ V	
Dropout voltage	$I_O = 1$ A	25° C	1.1			V	
Bias current		25° C	1			2	mA
Bias current change	$V_I = -7.2$ V to -25 V	0° C to 125° C				1.3	mA
	$I_O = 5$ mA to 1 A					0.5	
Peak output current		25° C	2.1			A	

† All characteristics are measured with a capacitor across the input of 0.33 μ F and a capacitor across the output of 0.1 μ F. All characteristics except noise voltage and ripple rejection ratio are measured using pulse techniques ($t_w \leq 10$ ms, duty cycle $\leq 5\%$). Output voltage changes due to changes in internal temperature must be taken into account separately.

TYPES μ A7906C, μ A7908C NEGATIVE-VOLTAGE REGULATORS

μ A7906C electrical characteristics at specified virtual junction temperature,
 $V_I = -11$ V, $I_O = 500$ mA (unless otherwise noted)

PARAMETER	TEST CONDITIONS†		μ A7906C			UNIT	
			MIN	TYP	MAX		
Output voltage			25°C	-5.75	-6	-6.25	V
	$I_O = 5$ mA to 1 A, $P \leq 15$ W	$V_I = -8$ V to -21 V,	0°C to 125°C	-5.7		-6.3	
Input regulation	$V_I = -8$ V to -25 V		25°C	5		120	mV
	$V_I = -9$ V to -13 V			1.5		60	
Ripple rejection	$V_I = -9$ V to -19 V,	$f = 120$ Hz	0°C to 125°C	54	60		dB
Output regulation	$I_O = 5$ mA to 1.5 A		25°C	14		120	mV
	$I_O = 250$ mA to 750 mA			4		60	
Temperature coefficient of output voltage	$I_O = 5$ mA		0°C to 125°C	-0.4			mV/°C
Output noise voltage	$f = 10$ Hz to 100 kHz		25°C	150			μ V
Dropout voltage	$I_O = 1$ A		25°C	1.1			V
Bias current			25°C	1		2	mA
Bias current change	$V_I = -8$ V to -25 V		0°C to 125°C			1.3	mA
	$I_O = 5$ mA to 1 A					0.5	
Peak output current			25°C	2.1			A

μ A7908C electrical characteristics at specified virtual junction temperature,
 $V_I = -14$ V, $I_O = 500$ mA (unless otherwise noted)

PARAMETER	TEST CONDITIONS†		μ A7908C			UNIT	
			MIN	TYP	MAX		
Output voltage			25°C	-7.7	-8	-8.3	V
	$I_O = 5$ mA to 1 A, $P \leq 15$ W	$V_I = -10.5$ V to -23 V,	0°C to 125°C	-7.6		-8.4	
Input regulation	$V_I = -10.5$ V to -25 V		25°C	6		160	mV
	$V_I = -11$ V to -17 V			2		80	
Ripple rejection	$V_I = -11.5$ V to -21.5 V,	$f = 120$ Hz	0°C to 125°C	54	60		dB
Output regulation	$I_O = 5$ mA to 1.5 A		25°C	12		160	mV
	$I_O = 250$ mA to 750 mA			4		80	
Temperature coefficient of output voltage	$I_O = 5$ mA		0°C to 125°C	-0.6			mV/°C
Output noise voltage	$f = 10$ Hz to 100 kHz		25°C	200			μ V
Dropout voltage	$I_O = 1$ A		25°C	1.1			V
Bias current			25°C	1		2	mA
Bias current change	$V_I = -10.5$ V to -25 V		0°C to 125°C			1	mA
	$I_O = 5$ mA to 1 A					0.5	
Peak output current			25°C	2.1			A

† All characteristics are measured with a capacitor across the input of 0.33 μ F and a capacitor across the output of 0.1 μ F. All characteristics except noise voltage and ripple rejection ratio are measured using pulse techniques ($t_w \leq 10$ ms, duty cycle $\leq 5\%$). Output voltage changes due to changes in internal temperature must be taken into account separately.

TYPES μ A7912C, μ A7915C NEGATIVE-VOLTAGE REGULATORS

μ A7912C electrical characteristics at specified virtual junction temperature,
 $V_I = -19$ V, $I_O = 500$ mA (unless otherwise noted)

PARAMETER	TEST CONDITIONS†	μ A7912C			UNIT	
		MIN	TYP	MAX		
Output voltage	$I_O = 5$ mA to 1 A, $V_I = -14.5$ V to -27 V, $P \leq 15$ W	25°C	-11.5	-12	-12.5	V
		0°C to 125°C	-11.4		-12.6	
Input regulation	$V_I = -14.5$ V to -30 V	25°C		10	240	mV
	$V_I = -16$ V to -22 V			3	120	
Ripple rejection	$V_I = -15$ V to -25 V, $f = 120$ Hz	0°C to 125°C	54	60		dB
Output regulation	$I_O = 5$ mA to 1.5 A	25°C		12	240	mV
	$I_O = 250$ mA to 750 mA			4	120	
Temperature coefficient of output voltage	$I_O = 5$ mA	0°C to 125°C		-0.8		mV/°C
Output noise voltage	$f = 10$ Hz to 100 kHz	25°C		300		μ V
Dropout voltage	$I_O = 1$ A	25°C		1.1		V
Bias current		25°C		1.5	3	mA
Bias current change	$V_I = -14.5$ V to -30 V	0°C to 125°C			1	mA
	$I_O = 5$ mA to 1 A				0.5	
Peak output current		25°C		2.1		A

μ A7915C electrical characteristics at specified virtual junction temperature,
 $V_I = -23$ V, $I_O = 500$ mA (unless otherwise noted)

PARAMETER	TEST CONDITIONS†	μ A7915C			UNIT	
		MIN	TYP	MAX		
Output voltage	$I_O = 5$ mA to 1 A, $V_I = -17.5$ V to -30 V, $P \leq 15$ W	25°C	-14.4	-15	-15.6	V
		0°C to 125°C	-14.25		-15.75	
Input regulation	$V_I = -17.5$ V to -30 V	25°C		11	300	mV
	$V_I = -20$ V to -26 V			3	150	
Ripple rejection	$V_I = -18.5$ V to -28.5 V, $f = 120$ Hz	0°C to 125°C	54	60		dB
Output regulation	$I_O = 5$ mA to 1.5 A	25°C		12	300	mV
	$I_O = 250$ mA to 750 mA			4	150	
Temperature coefficient of output voltage	$I_O = 5$ mA	0°C to 125°C		-1		mV/°C
Output noise voltage	$f = 10$ Hz to 100 kHz	25°C		375		μ V
Dropout voltage	$I_O = 1$ A	25°C		1.1		V
Bias current		25°C		1.5	3	mA
Bias current change	$V_I = -17.5$ V to -30 V	0°C to 125°C			1	mA
	$I_O = 5$ mA to 1 A				0.5	
Peak output current		25°C		2.1		A

† All characteristics are measured with a capacitor across the input of 0.33 μ F and a capacitor across the output of 0.1 μ F. All characteristics except noise voltage and ripple rejection ratio are measured using pulse techniques ($t_w \leq 10$ ms, duty cycle $\leq 5\%$). Output voltage changes due to changes in internal temperature must be taken into account separately.

TYPES μ A7918C, μ A7924C NEGATIVE-VOLTAGE REGULATORS

μ A7918C electrical characteristics at specified virtual junction temperature,
 $V_I = -27$ V, $I_O = 500$ mA (unless otherwise noted)

PARAMETER	TEST CONDITIONS†		μ A7918C			UNIT	
			MIN	TYP	MAX		
Output voltage	$I_O = 5$ mA to 1 A, $P < 15$ W	$V_I = -21$ V to -33 V, 0°C to 125°C	25°C	-17.3	-18	-18.7	V
		0°C to 125°C	-17.1		-18.9		
Input regulation	$V_I = -21$ V to -33 V	25°C		15	360	mV	
	$V_I = -24$ V to -30 V			5	180		
Ripple rejection	$V_I = -22$ V to -32 V, $I_O = 5$ mA to 1.5 A	$f = 120$ Hz	0°C to 125°C	54	60	360	dB
Output regulation	$I_O = 5$ mA to 1.5 A	25°C		12	360	mV	
	$I_O = 250$ mA to 750 mA			4	180		
Temperature coefficient of output voltage	$I_O = 5$ mA		0°C to 125°C	-1			mV/°C
Output noise voltage	$f = 10$ Hz to 100 kHz		25°C	450			μ V
Dropout voltage	$I_O = 1$ A		25°C	1.1			V
Bias current			25°C	1.5	3		mA
Bias current change	$V_I = -21$ V to -33 V	0°C to 125°C			1		mA
	$I_O = 5$ mA to 1 A				0.5		
Peak output current			25°C	2.1			A

μ A7924C electrical characteristics at specified virtual junction temperature,
 $V_I = -33$ V, $I_O = 500$ mA (unless otherwise noted)

PARAMETER	TEST CONDITIONS†		μ A7924C			UNIT	
			MIN	TYP	MAX		
Output voltage	$I_O = 5$ mA to 1 A, $P < 15$ W	$V_I = -27$ V to -38 V, 0°C to 125°C	25°C	-23	-24	-25	V
		0°C to 125°C	-22.8		-25.2		
Input regulation	$V_I = -27$ V to -38 V	25°C		18	480	mV	
	$V_I = -30$ V to -36 V			6	240		
Ripple rejection	$V_I = -28$ V to -38 V, $I_O = 5$ mA to 1.5 A	$f = 120$ Hz	0°C to 125°C	54	60	480	dB
Output regulation	$I_O = 5$ mA to 1.5 A	25°C		12	480	mV	
	$I_O = 250$ mA to 750 mA			4	240		
Temperature coefficient of output voltage	$I_O = 5$ mA		0°C to 125°C	-1			mV/°C
Output noise voltage	$f = 10$ Hz to 100 kHz		25°C	600			μ V
Dropout voltage	$I_O = 1$ A		25°C	1.1			V
Bias current			25°C	1.5	3		mA
Bias current change	$V_I = -27$ V to -38 V	0°C to 125°C			1		mA
	$I_O = 5$ mA to 1 A				0.5		
Peak output current			25°C	2.1			A

† All characteristics are measured with a capacitor across the input of 0.33 μ F and a capacitor across the output of 0.1 μ F. All characteristics except noise voltage and ripple rejection ratio are measured using pulse techniques ($t_w < 10$ ms, duty cycle $\leq 5\%$). Output voltage changes due to changes in internal temperature must be taken into account separately.

SERIES μ A79M00

NEGATIVE-VOLTAGE REGULATORS

absolute maximum ratings over operating temperature range (unless otherwise noted)

		μ A79M05M THRU μ A79M24M	μ A79M05C THRU μ A79M24C	UNIT
Input voltage	μ A79M20, μ A79M24	-40	-40	V
	All others	-35	-35	
Continuous total dissipation at 25°C free-air temperature (see Note 1)	KC (TO-220AB) package	2	2	W
	KD (TO-202AB) package	1.5	1.5	
	LA package	0.6	0.6	
Continuous total dissipation at (or below) 25°C case temperature (see Note 1)	KC and KD package	7.5	7.5	W
	LA package	5	5	
Operating free-air, case or virtual junction temperature range		-55 to 150	0 to 150	°C
Storage temperature range		-65 to 150	-65 to 150	°C
Lead temperature 1/16 inch from case for 10 seconds	KC and KD packages		260	°C
Lead temperature 1/16 inch from case for 60 seconds	LA package	300	300	°C

NOTE 1: For operation above 25°C free-air or case temperature, refer to Dissipation Derating Curves, Figures 1 through 4, page 188.

recommended operating conditions

		MIN	MAX	UNIT
Input voltage, V_I	μ A79M05	-7	-25	V
	μ A79M06	-8	-25	
	μ A79M08	-10.5	-25	
	μ A79M12	-14.5	-30	
	μ A79M15	-17.5	-30	
	μ A79M20	-23	-35	
	μ A79M24	-27	-38	
Output current, I_O			500	mA
Operating virtual junction temperature, T_J	μ A79M05M thru μ A79M24M	-55	150	°C
	μ A79M05C thru μ A79M24C	0	125	

TYPES μ A79M05M, μ A79M05C NEGATIVE-VOLTAGE REGULATORS

μ A79M05M, μ A79M05C electrical characteristics at specified virtual junction temperature,
 $V_I = -10$ V, $I_O = 350$ mA (unless otherwise noted)

PARAMETER	TEST CONDITIONS [†]		μ A79M05M			μ A79M05C			UNIT	
			MIN	TYP	MAX	MIN	TYP	MAX		
Output voltage	$I_O = 5$ mA to 350 mA, $V_I = -7$ V to -25 V		25°C	-4.8	-5	-5.2	-4.8	-5	-5.2	V
			-55°C to 150°C	-4.75		-5.25				
			0°C to 125°C				-4.75		-5.25	
Input regulation	$V_I = -7$ V to -25 V		25°C	7	50		7	50	mV	
	$V_I = -8$ V to -18 V			3	30		3	30		
Ripple rejection	$V_I = -8$ V to -18 V, $f = 120$ Hz	$I_O = 100$ mA	-55°C to 150°C	50					dB	
			0°C to 125°C				50			
		$I_O = 300$ mA	25°C	54	60		54	60		
Output regulation	$I_O = 5$ mA to 500 mA		25°C	75	100		75	100	mV	
	$I_O = 5$ mA to 350 mA			50			50			
Temperature coefficient of output voltage	$I_O = 5$ mA		-55°C to 150°C	-0.4					mV/°C	
			0°C to 125°C				0.4			
Output noise voltage	$f = 10$ Hz to 100 kHz		25°C	125			125		μ V	
Dropout voltage			25°C	1.1			1.1		V	
Bias current			25°C	1	2		1	2	mA	
Bias current change	$V_I = -8$ V to -25 V		-55°C to 150°C		0.4				mA	
			0°C to 125°C				0.4			
	$I_O = 5$ mA to 350 mA		-55°C to 150°C		0.4					
			0°C to 125°C				0.4			
Short circuit output current	$V_I = -30$ V		25°C	140			140		mA	
Peak output current			25°C	650			650		A	

[†] All characteristics are measured with a 2- μ F capacitor across the input and a 1- μ F capacitor across the output. All characteristics except noise voltage and ripple rejection ratio are measured using pulse techniques ($t_w \leq 10$ ms, duty cycle $\leq 5\%$). Output voltage changes due to changes in internal temperature must be taken into account separately.

TYPES μ A79M06M, μ A79M06C NEGATIVE-VOLTAGE REGULATORS

μ A79M06M, μ A79M06C electrical characteristics at specified virtual junction temperature,
 $V_I = -11$ V, $I_O = 350$ mA (unless otherwise noted)

PARAMETER	TEST CONDITIONS†		μ A79M06M			μ A79M06C			UNIT	
			MIN	TYP	MAX	MIN	TYP	MAX		
Output voltage	$I_O = 5$ mA to 350 mA, $V_I = -8$ V to -25 V		25°C	-5.75	-6	-6.25	-5.75	-6	-6.25	V
			-55°C to 150°C	-5.7		-6.3				
			0°C to 125°C			-5.7		-6.3		
Input regulation	$V_I = -8$ V to -25 V		25°C	7	60	7	60	mV		
	$V_I = -9$ V to -19 V			3	40	3	40			
Ripple rejection	$V_I = -9$ V to -19 V, $f = 120$ Hz	$I_O = 100$ mA	-55°C to 150°C	50				dB		
			0°C to 125°C			50				
		$I_O = 300$ mA	25°C	54	60	54	60			
Output regulation	$I_O = 5$ mA to 500 mA		25°C	80	120	80	120	mV		
	$I_O = 5$ mA to 350 mA			55	55					
Temperature coefficient of output voltage	$I_O = 5$ mA		-55°C to 150°C	-0.4				mV/°C		
			0°C to 125°C			-0.4				
Output noise voltage	$f = 10$ Hz to 100 kHz		25°C	150		150		μ V		
Dropout voltage			25°C	1.1		1.1		V		
Bias current			25°C	1	2	1	2	mA		
Bias current change	$V_I = -9$ V to -25 V		-55°C to 150°C	0.4				mA		
			0°C to 125°C			0.4				
	$I_O = 5$ mA to 350 mA		-55°C to 150°C	0.4						
			0°C to 125°C			0.4				
Short circuit output current	$V_I = -30$ V		25°C	140		140		mA		
Peak output current			25°C	650		650		A		

† All characteristics are measured with a 2- μ F capacitor across the input and a 1- μ F capacitor across the output. All characteristics except noise voltage and ripple rejection ratio are measured using pulse techniques ($t_w \leq 10$ ms, duty cycle $\leq 5\%$). Output voltage changes due to changes in internal temperature must be taken into account separately.

TYPES μ A79M08M, μ A79M08C NEGATIVE-VOLTAGE REGULATORS

μ A79M08M, μ A79M08C electrical characteristics at specified virtual junction temperature,
 $V_I = -19$ V, $I_O = 350$ mA (unless noted)

PARAMETER	TEST CONDITIONS [†]		μ A79M08M			μ A79M08C			UNIT	
			MIN	TYP	MAX	MIN	TYP	MAX		
Output voltage	$I_O = 5$ mA to 350 mA, $V_I = -10.5$ V to -25 V		25°C	-7.7	-8	-8.3	-7.7	-8	-8.3	V
			-55°C to 150°C	-7.6		-8.4				
			0°C to 125°C				-7.6		-8.4	
Input regulation	$V_I = -10.5$ V to -25 V		25°C	8	80		8	80	mV	
	$V_I = -11$ V to -21 V			4	50		4	50		
Ripple rejection	$V_I = -11.5$ V to -21.5 V, $f = 120$ Hz	$I_O = 100$ mA	-55°C to 150°C	50			50		dB	
			0°C to 125°C				50			
		$I_O = 300$ mA	25°C	54	59		54	59		
Output regulation	$I_O = 5$ mA to 500 mA		25°C	90	160		90	160	mV	
	$I_O = 5$ mA to 350 mA			60			60			
Temperature coefficient of output voltage	$I_O = 5$ mA		-55°C to 150°C	-0.6			-0.6		mV/°C	
			0°C to 125°C				-0.6			
Output noise voltage	$f = 10$ Hz to 100 kHz		25°C	200			200		μ V	
Dropout voltage			25°C	1.1			1.1		V	
Bias current			25°C	1	2		1	2	mA	
Bias current change	$V_I = -10.5$ V to -25 V		-55°C to 150°C		0.4				mA	
			0°C to 125°C				0.4			
	$I_O = 5$ mA to 350 mA		-55°C to 150°C		0.4					
			0°C to 125°C				0.4			
Short circuit output current	$V_I = -30$ V		25°C	140			140		mA	
Peak output current			25°C	650			650		A	

[†]All characteristics are measured with a 2- μ F capacitor across the input and a 1- μ F capacitor across the output. All characteristics except noise voltage and ripple rejection ratio are measured using pulse techniques ($t_W \leq 10$ ms, duty cycle $\leq 5\%$). Output voltage changes due to changes in internal temperature must be taken into account separately.

TYPES μ A79M12M, μ A79M12C

NEGATIVE-VOLTAGE REGULATORS

μ A79M12M, μ A79M12C electrical characteristics at specified virtual junction temperature,
 $V_I = -19$ V, $I_O = 350$ mA (unless otherwise noted)

PARAMETER	TEST CONDITIONS†		μ A79M12M			μ A79M12C			UNIT	
			MIN	TYP	MAX	MIN	TYP	MAX		
Output voltage	$I_O = 5$ mA to 350 mA, $V_I = -14.5$ V to -30 V		25°C	-11.5	-12	-12.5	-11.5	-12	-12.5	V
			-55°C to 150°C	-11.4		-12.6				
			0°C to 125°C				-11.4		-12.6	
Input regulation	$V_I = -14.5$ V to -30 V		25°C	9	80	9	80	mV		
	$V_I = -15$ V to -25 V		25°C	5	50	5	50			
Ripple rejection	$V_I = -15$ V to -25 V, $f = 120$ Hz	$I_O = 100$ mA	-55°C to 150°C	50				dB		
			0°C to 125°C			50				
		$I_O = 300$ mA	25°C	54	60	54	60			
Output regulation	$I_O = 5$ mA to 500 mA		25°C	65	240	65	240	mV		
	$I_O = 5$ mA to 350 mA		25°C	45		45				
Temperature coefficient of output voltage	$I_O = 5$ mA		-55°C to 150°C	-0.8				mV/°C		
			0°C to 125°C			-0.8				
Output noise voltage	$f = 10$ Hz to 100 kHz		25°C	300		300		μ V		
Dropout voltage			25°C	1.1		1.1		V		
Bias current			25°C	1.5	3	1.5	3	mA		
Bias current change	$V_I = -14.5$ V to -30 V		-55°C to 150°C		0.4			mA		
			0°C to 125°C				0.4			
	$I_O = 5$ mA to 350 mA		-55°C to 150°C		0.4					
			0°C to 125°C				0.4			
Short circuit output current	$V_I = -30$ V		25°C	140		140		mA		
Peak output current			25°C	650		650		A		

† All characteristics are measured with a 2- μ F capacitor across the input and a 1- μ F capacitor across the output. All characteristics except noise voltage and ripple rejection ratio are measured using pulse techniques ($t_w \leq 10$ ms, duty cycle $\leq 5\%$). Output voltage changes due to changes in internal temperature must be taken into account separately.

TYPES μ A79M15M, μ A79M15C NEGATIVE-VOLTAGE REGULATORS

μ A79M15M, μ A79M15C electrical characteristics at specified virtual junction temperature,
 $V_I = -23$ V, $I_O = 350$ mA (unless otherwise noted)

PARAMETER	TEST CONDITIONS†	μ A79M15M			μ A79M15C			UNIT	
		MIN	TYP	MAX	MIN	TYP	MAX		
Output voltage	$I_O = 5$ mA to 350 mA, $V_I = -17.5$ V to -30 V	25°C	-14.4	-15	-15.6	-14.4	-15	-15.6	V
		-55°C to 150°C	-14.25		-15.75				
		0°C to 125°C				-14.25		-15.75	
Input regulation	$V_I = -17.5$ V to -30 V	25°C	9	80	9	80	mV		
	$V_I = -18$ V to -28 V		7	50	7	50			
Ripple rejection	$V_I = -18.5$ V to -28.5 V, $I_O = 100$ mA $f = 120$ Hz	-55°C to 150°C	50						dB
		0°C to 125°C				50			
		25°C	54	59	54	59			
Output regulation	$I_O = 5$ mA to 500 mA	25°C	65	240	65	240	mV		
	$I_O = 5$ mA to 350 mA		45		45				
Temperature coefficient of output voltage	$I_O = 5$ mA	-55°C to 150°C	-1						mV/°C
		0°C to 125°C				-1			
Output noise voltage	$f = 10$ Hz to 100 kHz	25°C	375			375			μ V
Dropout voltage		25°C	1.1			1.1			V
Bias current		25°C	1.5	3	1.5	3	mA		
Bias current change	$V_I = -17.5$ V to -30 V $I_O = 5$ mA to 350 mA	-55°C to 150°C	0.4						mA
		0°C to 125°C				0.4			
		-55°C to 150°C	0.4						
		0°C to 125°C				0.4			
Short circuit output current	$V_I = -30$ V	25°C	140			140			mA
Peak output current		25°C	650			650			A

† All characteristics are measured with a 2- μ F capacitor across the input and a 1- μ F capacitor across the output. All characteristics except noise voltage and ripple rejection ratio are measured using pulse techniques ($t_W \leq 10$ ms, duty cycle $\leq 5\%$). Output voltage changes due to changes in internal temperature must be taken into account separately.

TYPES μ A79M20M, μ A79M20C NEGATIVE-VOLTAGE REGULATORS

μ A79M20M, μ A79M20C electrical characteristics at specified virtual junction temperature,
 $V_I = -29$ V, $I_O = 350$ mA (unless otherwise noted)

PARAMETER	TEST CONDITIONS†		μ A79M20M			μ A79M20C			UNIT			
			MIN	TYP	MAX	MIN	TYP	MAX				
Output voltage	$I_O = 5$ mA to 350 mA, $V_I = -23$ V to -35 V		25°C	-19.2	-20	-20.8	-19.2	-20	-20.8	V		
			-55°C to 150°C	-19		-21						
			0°C to 125°C			-19		-21				
Input regulation	$V_I = -23$ V to -35 V		25°C	12		80		12		80		mV
	$V_I = -24$ V to -34 V			10		70		10		70		
Ripple rejection	$V_I = -24$ V to -34 V, $f = 120$ Hz	$I_O = 100$ mA	-55°C to 150°C	50						dB		
			0°C to 125°C			50						
		$I_O = 300$ mA	25°C	54	58	54	58	54	58			
Output regulation	$I_O = 5$ mA to 500 mA		25°C	75		300		75		300		mV
	$I_O = 5$ mA to 350 mA			50		50		50		50		
Temperature coefficient of output voltage	$I_O = 5$ mA		-55°C to 150°C	-1						mV/°C		
			0°C to 125°C			-1						
Output noise voltage	$f = 10$ Hz to 100 kHz		25°C	500		500		500		μ V		
Dropout voltage			25°C	1.1		1.1		1.1		V		
Bias current			25°C	1.5	3.5	1.5	3.5	1.5	3.5	mA		
Bias current change	$V_I = -23$ V to -35 V		-55°C to 150°C	0.4						mA		
			0°C to 125°C			0.4						
	$I_O = 5$ mA to 350 mA		-55°C to 150°C	0.4								
			0°C to 125°C			0.4						
Short circuit output current	$V_I = -30$ V		25°C	140		140		140		mA		
Peak output current			25°C	650		650		650		A		

†All characteristics are measured with a 2- μ F capacitor across the input and a 1- μ F capacitor across the output. All characteristics except noise voltage and ripple rejection ratio are measured using pulse techniques ($t_w \leq 10$ ms, duty cycle $\leq 5\%$). Output voltage changes due to changes in internal temperature must be taken into account separately.

TYPES μ A79M24M, μ A79M24C NEGATIVE-VOLTAGE REGULATORS

μ A79M24M, μ A79M24C electrical characteristics at specified virtual junction temperature,
 $V_I = -33$ V, $I_O = 350$ mA (unless otherwise noted)

PARAMETER	TEST CONDITIONS†		μ A79M24M			μ A79M24C			UNIT	
			MIN	TYP	MAX	MIN	TYP	MAX		
Output voltage			25°C	-23	-24	-25	-23	-24	-25	V
	$I_O = 5$ mA to 350 mA, $V_I = -27$ V to -38 V		-55°C to 150°C	-22.8			-25.2			
			0°C to 125°C				-22.8 -25.2			
Input regulation	$V_I = -27$ V to -38 V		25°C	12 80			12 80			mV
	$V_I = -28$ V to -38 V			12 70			12 70			
Ripple rejection	$V_I = -28$ V to -38 V, $f = 120$ Hz	$I_O = 100$ mA	-55°C to 150°C	50			50			dB
			0°C to 125°C							
		$I_O = 300$ mA	25°C	54 58			54 58			
Output regulation	$I_O = 5$ mA to 500 mA		25°C	75 300			75 300			mV
	$I_O = 5$ mA to 350 mA			50			50			
Temperature coefficient of output voltage	$I_O = 5$ mA		-55°C to 150°C	-1						mV/°C
			0°C to 125°C				-1			
Output noise voltage	$f = 10$ Hz to 100 kHz		25°C	600			600			μ V
Dropout voltage			25°C	1.1			1.1			V
Bias current			25°C	1.5 3.5			1.5 3.5			mA
Bias current change	$V_I = -27$ V to -38 V		-55°C to 150°C	0.4						mA
			0°C to 125°C				0.4			
	$I_O = 5$ mA to 350 mA		-55°C to 150°C	0.4						
			0°C to 125°C				0.4			
Short circuit output current	$V_I = -30$ V		25°C	140			140			mA
Peak output current			25°C	650			650			A

† All characteristics are measured with a 2- μ F capacitor across the input and a 1- μ F capacitor across the output. All characteristics except noise voltage and ripple rejection ratio are measured using pulse techniques ($t_w < 10$ ms, duty cycle $< 5\%$). Output voltage changes due to changes in internal temperature must be taken into account separately.

SERIES μ A79M00

NEGATIVE-VOLTAGE REGULATORS

THERMAL INFORMATION

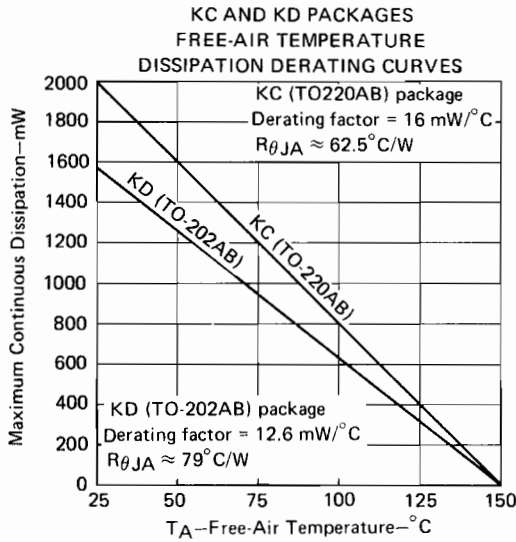

FIGURE 1

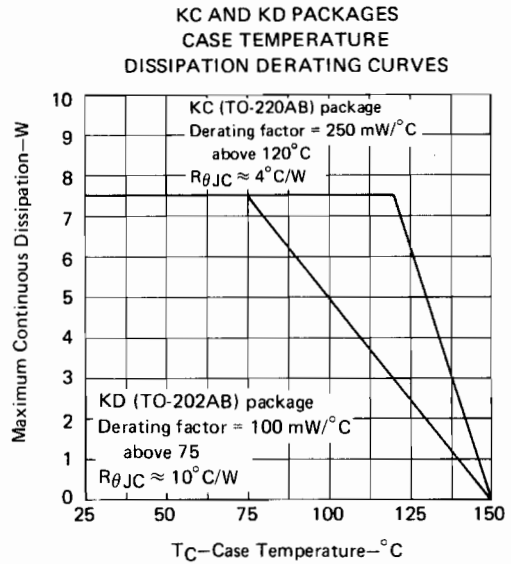

FIGURE 2

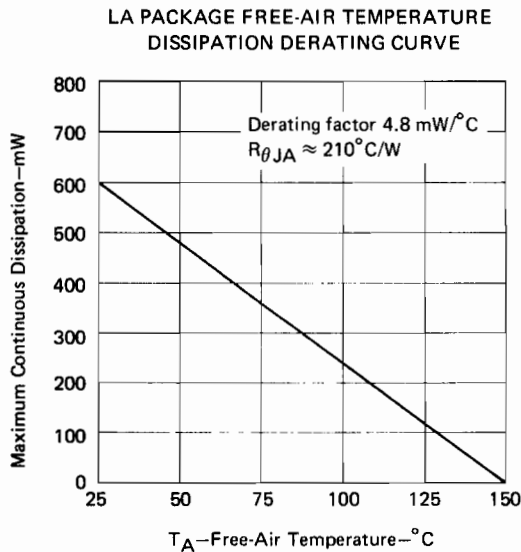

FIGURE 3

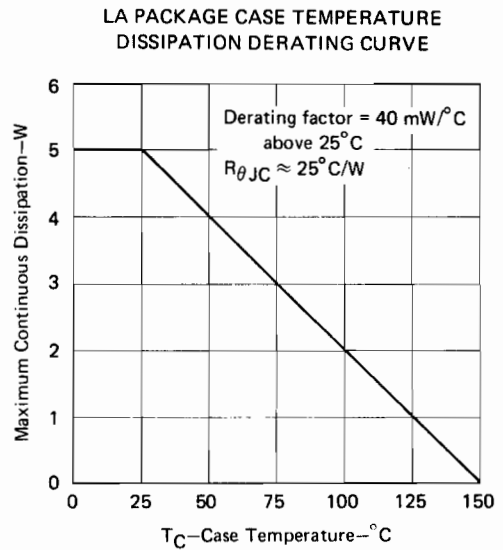

FIGURE 4

VOLTAGE REGULATOR CIRCUITS ORDERING INSTRUCTIONS AND MECHANICAL DATA

ORDERING INSTRUCTIONS

Electrical characteristics presented in this data book, unless otherwise noted, apply for the circuit type(s) listed in the page heading regardless of package. The availability of a circuit function in a particular package is denoted by an alphabetical reference above the pin-connection diagram(s). These alphabetical references refer to mechanical outline drawing shown in this section.

Factory orders for circuits described in this data book should include a five-part type number as explained in the following example.

EXAMPLE: TL 022M JG /883B -00

1. Prefix
MUST CONTAIN TWO LETTERS

TL	TI Linear Control Products
LM	Second source for National
SG	Second source for Silicon General
uA	Second source for Fairchild

2. Unique Circuit Designator Including Temperature Range
MUST CONTAIN THREE TO SEVEN CHARACTERS

(From Individual Data Sheets)

Examples: 104 1524
 497M 78L05AC

3. Package
MUST CONTAIN ONE OR TWO LETTERS

J, JG, KC, KD, L, LA, N, or U
(From Pin-Connection Diagram on Individual Data Sheet)

4. MIL-STD-883B Method 5004, Class B

5. Instructions (Dash No.)
MUST CONTAIN TWO NUMBERS
(From Dash No. Column of Following Table)

PACKAGES	SOLDER-DIPPED LEADS	ORDER DASH NO.
J, JG, L, LA, LP, N, P, U	NO	00
J, JG, L, LA, LP, N, P, U	YES	10
KC, KD	NO	N/A

N/A—Not applicable, omit dash number

OMIT WHEN NOT APPLICABLE

Circuits are shipped in one of the carriers shown below. Unless a specific method of shipment is specified by the customer (with possible additional costs), circuits will be shipped in the most practical carrier.

<p>Flat (U)</p> <ul style="list-style-type: none"> —Barnes Carrier —Milton Ross Carrier 	<p>Dual-In-Line (J, JG, N, P)</p> <ul style="list-style-type: none"> —Slide Magazines —A-Channel Plastic Tubing —Barnes Carrier —Sectioned Cardboard Box —Individual Plastic Box 	<p>Plug-In (L, LA, LP)</p> <ul style="list-style-type: none"> —Barnes Carrier —Sectioned Cardboard Box —Individual Cardboard Box
--	--	--

VOLTAGE REGULATOR CIRCUITS

ORDERING INSTRUCTIONS AND MECHANICAL DATA

J ceramic dual-in-line packages

These hermetically sealed dual-in-line packages consist of a ceramic base, ceramic cap, and a 14- or 16-lead frame. Hermetic sealing is accomplished with glass. The packages are intended for insertion in mounting-hole rows on 0.300 (7,62) centers (see Note a). Once the leads are compressed and inserted, sufficient tension is provided to secure the package in the board during soldering. Tin-plated ("bright-dipped") leads (-00) require no additional cleaning or processing when used in soldered assembly.

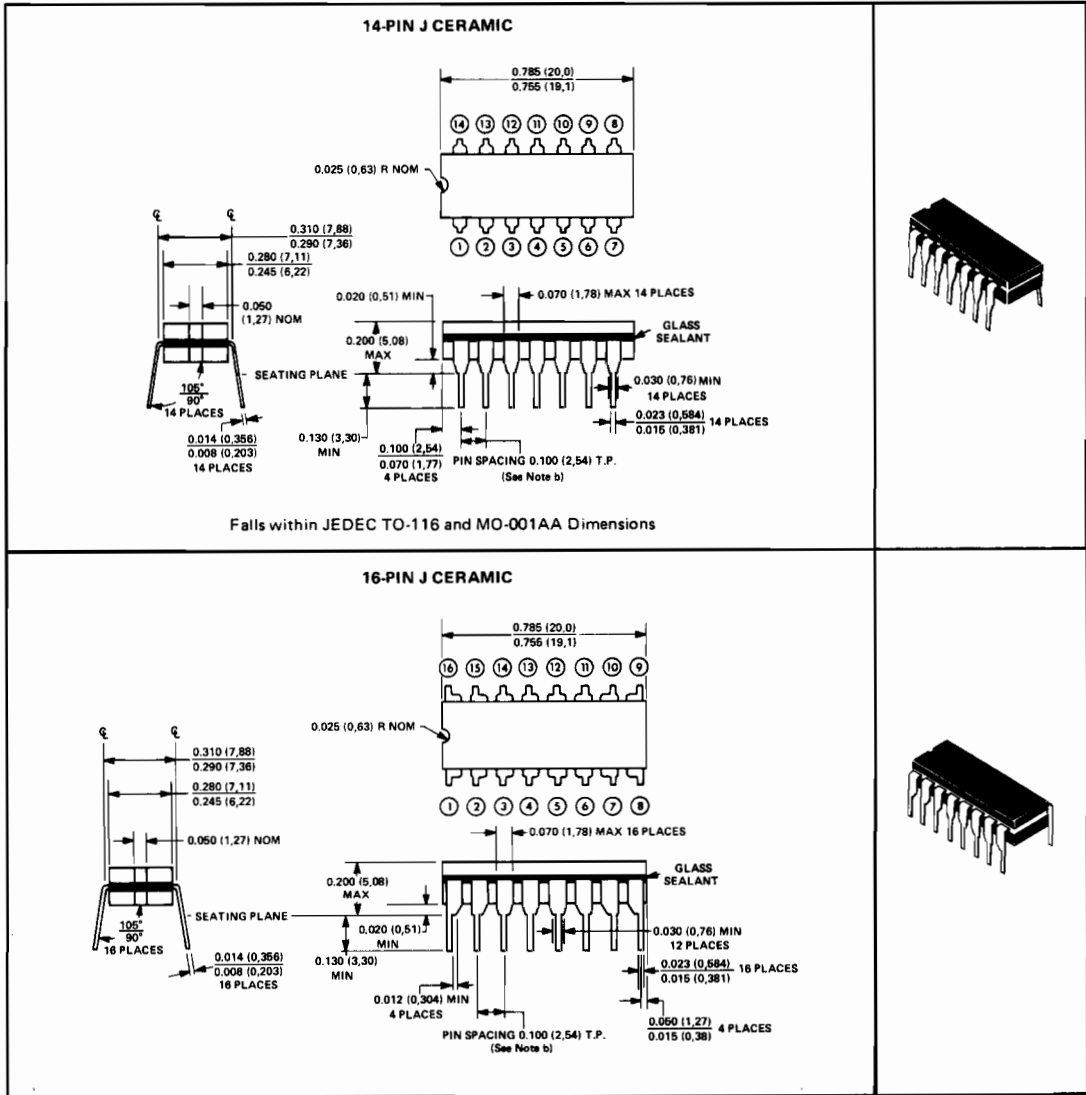

NOTES: a. All dimensions are in inches and parenthetically in millimeters. Inch dimensions govern.
 b. Each pin centerline is located within 0.010 (0,26) of its true longitudinal position.

VOLTAGE REGULATOR CIRCUITS ORDERING INSTRUCTIONS AND MECHANICAL DATA

JG ceramic dual-in-line package

This hermetically sealed dual-in-line package consists of a ceramic base, ceramic cap, and 8-lead frame. The package is intended for insertion in mounting-hole rows on 0.300 (7,62) centers (see Note a). Once the leads are compressed and inserted, sufficient tension is provided to secure the package in the board during soldering. Tin-plated ("bright-dipped") leads require no additional cleaning or processing when used in soldered assembly.

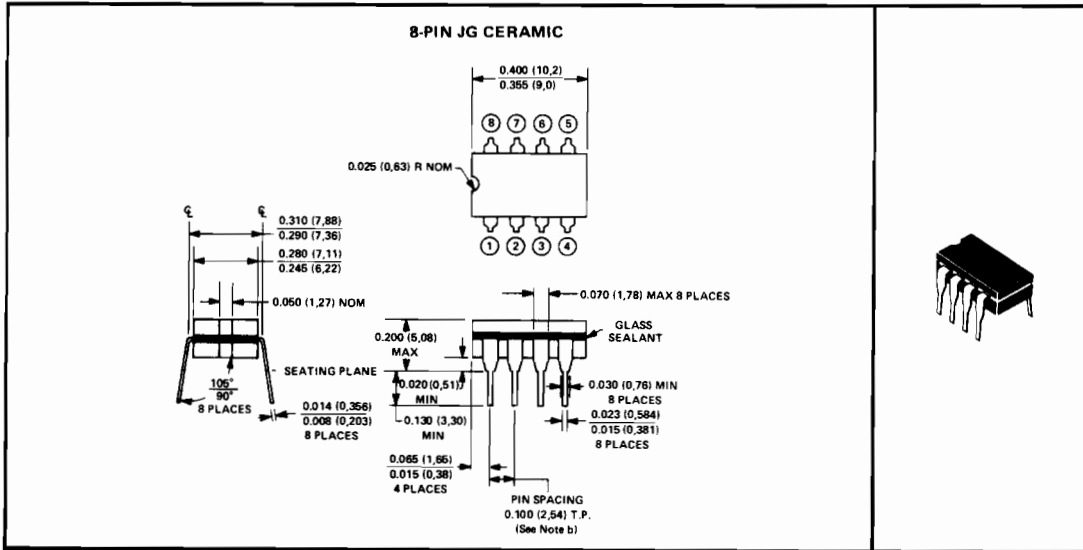

NOTES: a. All dimensions are in inches and parenthetically in millimeters. Inch dimensions govern.
b. Each pin centerline is located within 0.010 (0,26) of its true longitudinal position.

VOLTAGE REGULATOR CIRCUITS ORDERING INSTRUCTIONS AND MECHANICAL DATA

KC (TO-220AB) package

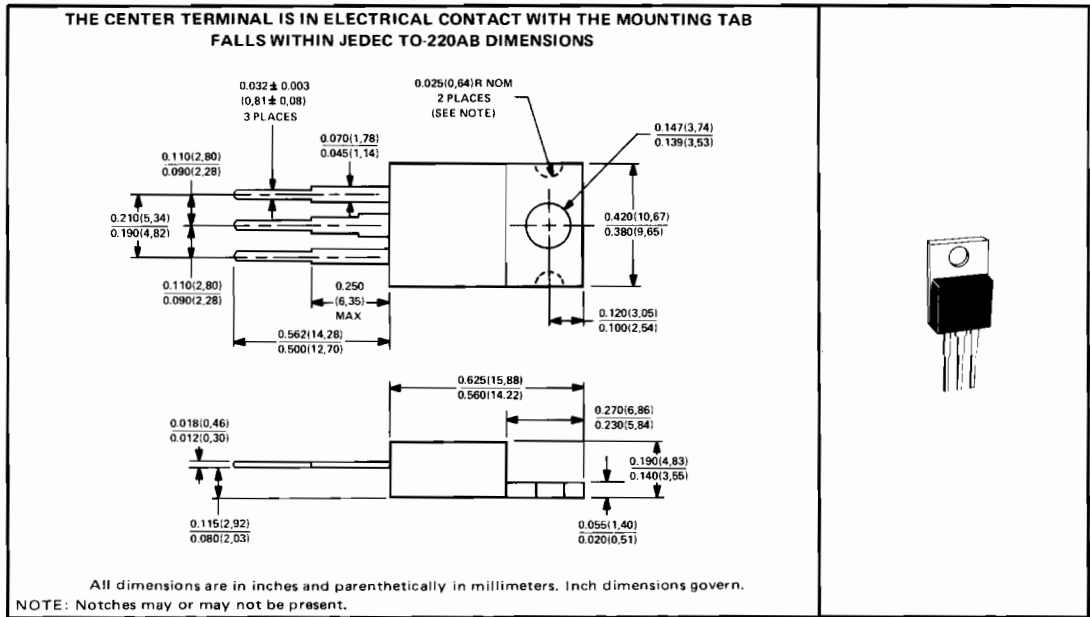

KD (TO-202AB) package

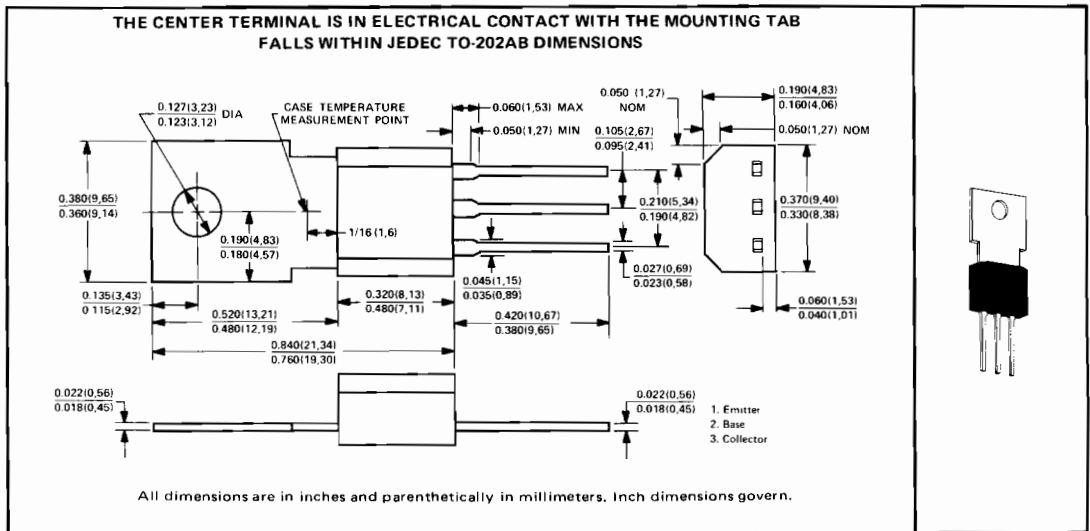

VOLTAGE REGULATOR CIRCUITS ORDERING INSTRUCTIONS AND MECHANICAL DATA

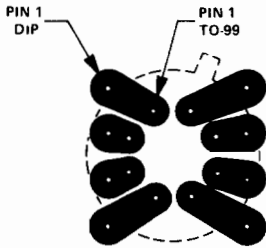

TYPICAL
P.C. BOARD
LAYOUT

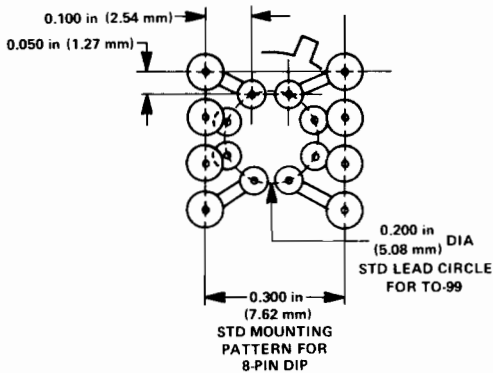
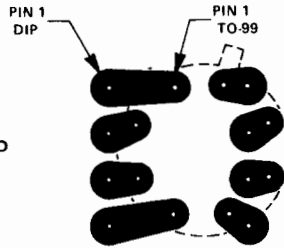

0.200-DIAMETER STANDARD
LEAD CIRCLE FOR TO-99

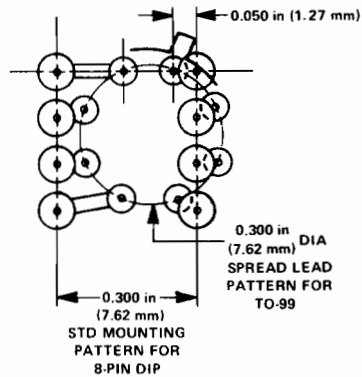

0.300-DIAMETER SPREAD
LEAD CIRCLE FOR TO-99

PRINTED CIRCUIT BOARD PATTERN THAT ALLOWS
INTERCHANGEABILITY OF 8-PIN DUAL-IN-LINE
PACKAGE WITH TO-99 PLUG-IN PACKAGE

VOLTAGE REGULATOR CIRCUITS

ORDERING INSTRUCTIONS AND MECHANICAL DATA

L plug-in package

These hermetically sealed plug-in packages each consist of a welded metal base and cap with individual leads secured by an insulating glass sealant. The gold-plated leads (—00) require no additional cleaning or processing when used in soldered assembly.

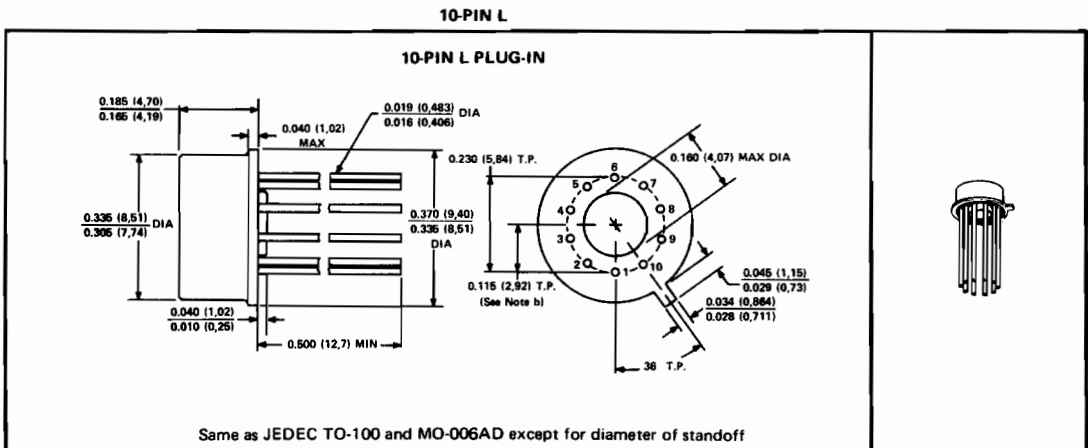
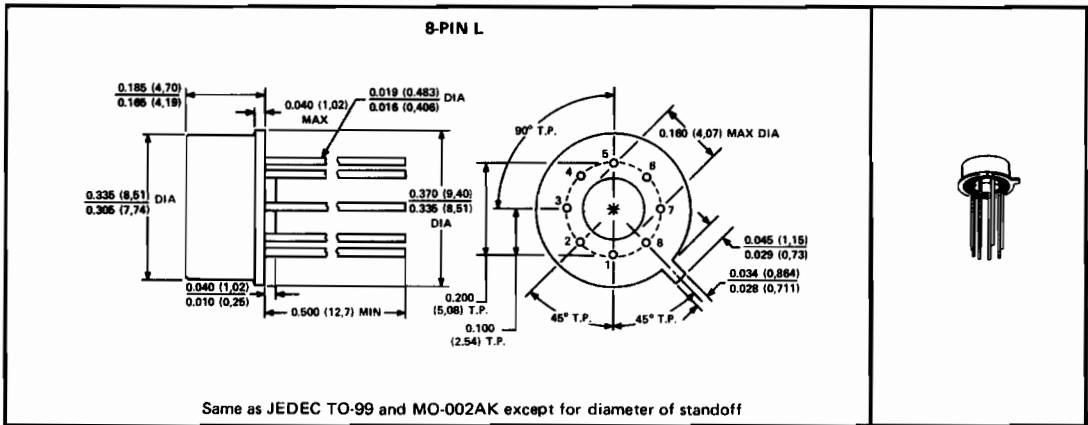

- NOTES: a. All linear dimensions are in inches and parenthetically in millimeters. Inch dimensions govern.
 b. Each lead is located within 0.007 (0.18) of its true position at maximum material condition.

VOLTAGE REGULATOR CIRCUITS ORDERING INSTRUCTIONS AND MECHANICAL DATA

LA Plug-in package

These hermetically sealed plug-in packages each consist of a welded metal base and cap with individual leads secured by an insulating glass sealant. The gold-plated leads (−00) require no additional cleaning or processing when used in soldered assembly.

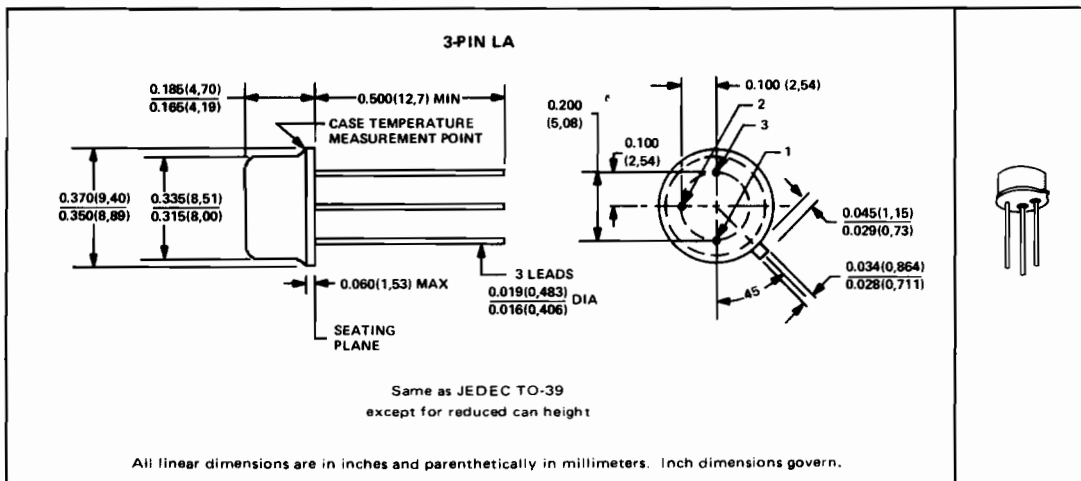

LP *Silect*[†] plastic package

The silect package is an encapsulation in a plastic compound specifically designed for this purpose. The package will withstand soldering temperatures without deformation. The package exhibits stable characteristics under high-humidity conditions and is capable of meeting MIL-STD-202C, Method 106B.

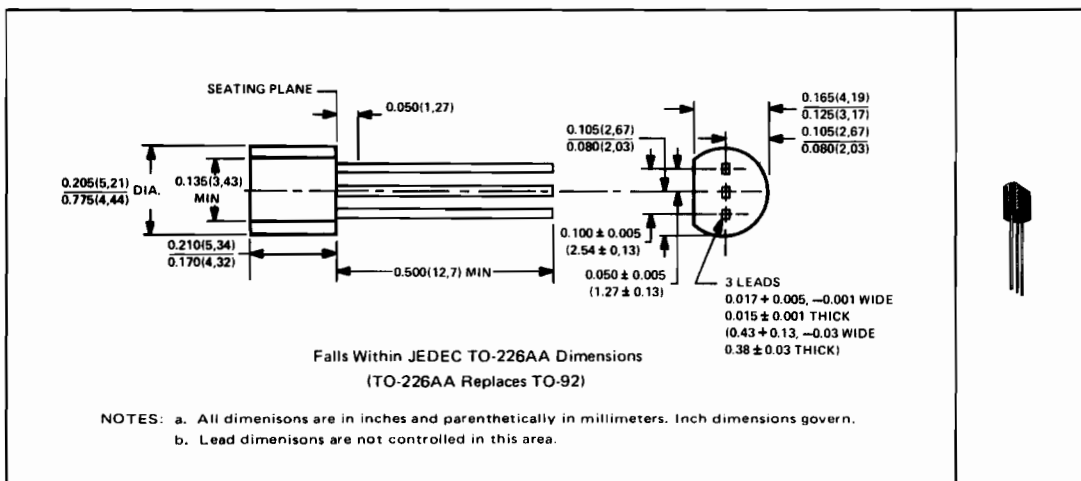

[†]Trademark Registered U.S. Patent Office.

VOLTAGE REGULATOR CIRCUITS

ORDERING INSTRUCTIONS AND MECHANICAL DATA

N plastic dual-in-line packages

These dual-in-line packages consist of a circuit mounted on a 14- or 16-lead frame and encapsulated within an electrically nonconductive plastic compound. The compound will withstand soldering temperature with no deformation and circuit performance characteristics remain stable when operated in high-humidity conditions. The packages are intended for insertion in mounting-hole rows on 0.300 (7,62) centers (see Note a). Once the leads are compressed and inserted, sufficient tension is provided to secure the package in the board during soldering. Leads require no additional cleaning or processing when used in soldered assembly.

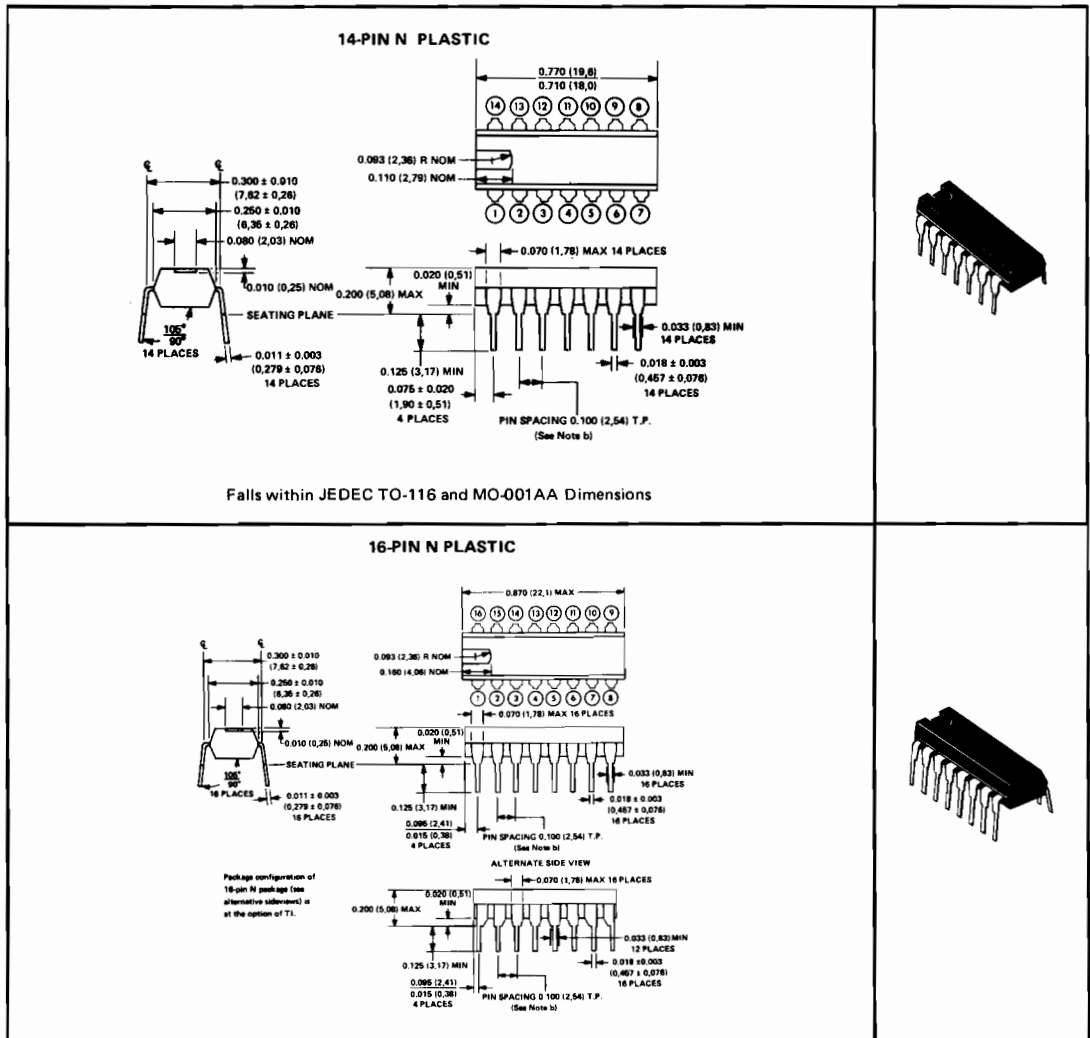

NOTES: a. All dimensions are in inches and parenthetically in millimeters. Inch dimensions govern.
 b. Each pin centerline is located within 0.010 (0,26) of its true longitudinal position.

VOLTAGE REGULATOR CIRCUITS

ORDERING INSTRUCTIONS AND MECHANICAL DATA

P dual-in-line plastic package

This dual-in-line package consists of a circuit mounted on an 8-lead frame and encapsulated in an electrically, nonconductive plastic compound. The compound will withstand soldering temperature with no deformation and circuit performance characteristics remain stable when operated under high-humidity conditions. This package is intended for insertion in mounting hole rows on 0.300 (7,62) centers (see Note a). Once the leads are compressed and inserted, sufficient tension is provided to secure the package in the board during soldering. Silver-plated leads require no additional cleaning or processing when used in soldered assembly.

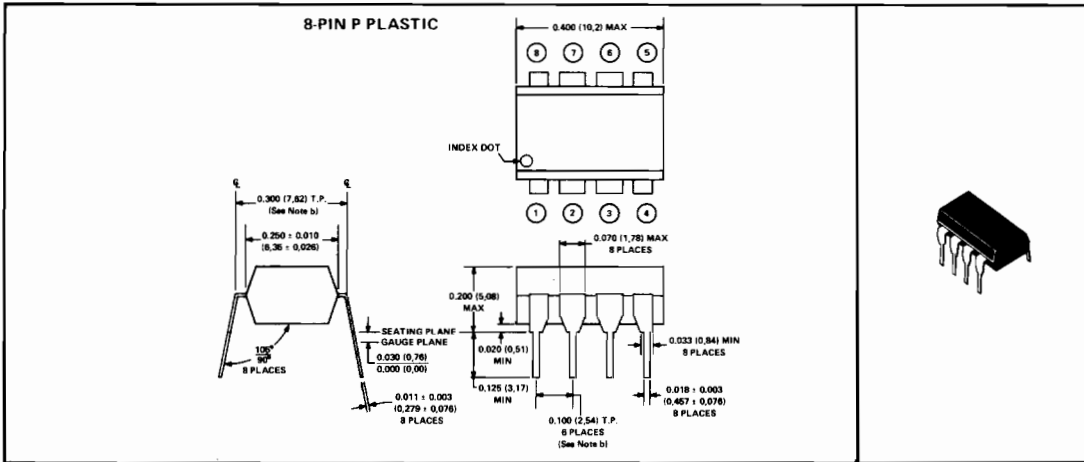

- NOTES: a. All dimensions are in inches and parenthetically in millimeters. Inch dimensions govern.
 b. Each pin centerline is within 0.005 (0.127) radius of true position at the gauge plane with maximum material condition and unit installed.

VOLTAGE REGULATOR CIRCUITS ORDERING INSTRUCTIONS AND MECHANICAL DATA

U ceramic flat packages

These flat packages consist of a ceramic base, ceramic cap, and 10- or 14-lead frame. Circuit bars are alloy-mounted. Hermetic sealing is accomplished with glass. Tin-plated leads require no additional cleaning or processing when used in soldered assembly.

