

DENON

Hi-Fi Component

SERVICE MANUAL MODEL DN-650F

CD PLAYER

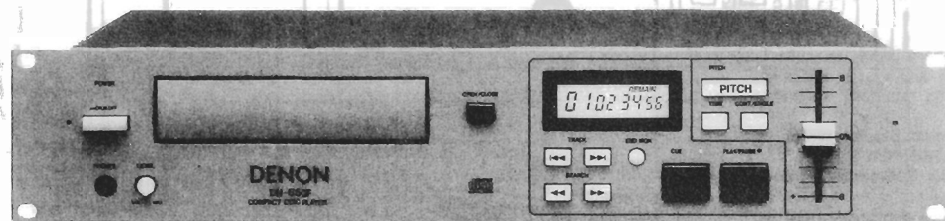

— TABLE OF CONTENTS —

OPERATING INSTRUCTIONS	2 - 8
SPECIFICATIONS	9
DISASSEMBLY	10
NOTE FOR HANDLING OF LASER PICK-UP	11
SERVO ADJUSTMENT	12, 13
NOTE FOR PARTS LIST	13
PRINTED WIRING BOARD PARTS LIST	14
PRINTED WIRING BOARD PATTERNS	14, 15
EXPLODED VIEW OF CHASSIS AND CABINET	16
PARTS LIST OF EXPLODED VIEW	17
PACKING & ACCESSORIES	18
PARTS LIST OF FIG-71 MECHANISM UNIT	18
EXPLODED VIEW OF FIG-71 MECHANISM UNIT	19
WIRING DIAGRAM	20
SEMICONDUCTORS	21 - 23
IC TERMINAL FUNCTION LIST	24 - 30
SCHEMATIC DIAGRAM	31

NIPPON COLUMBIA CO., LTD.

FRONT PANEL
FRONTPLATTE
PANNEAU AVANT
PANEL FRONTAL
FRANSIDA

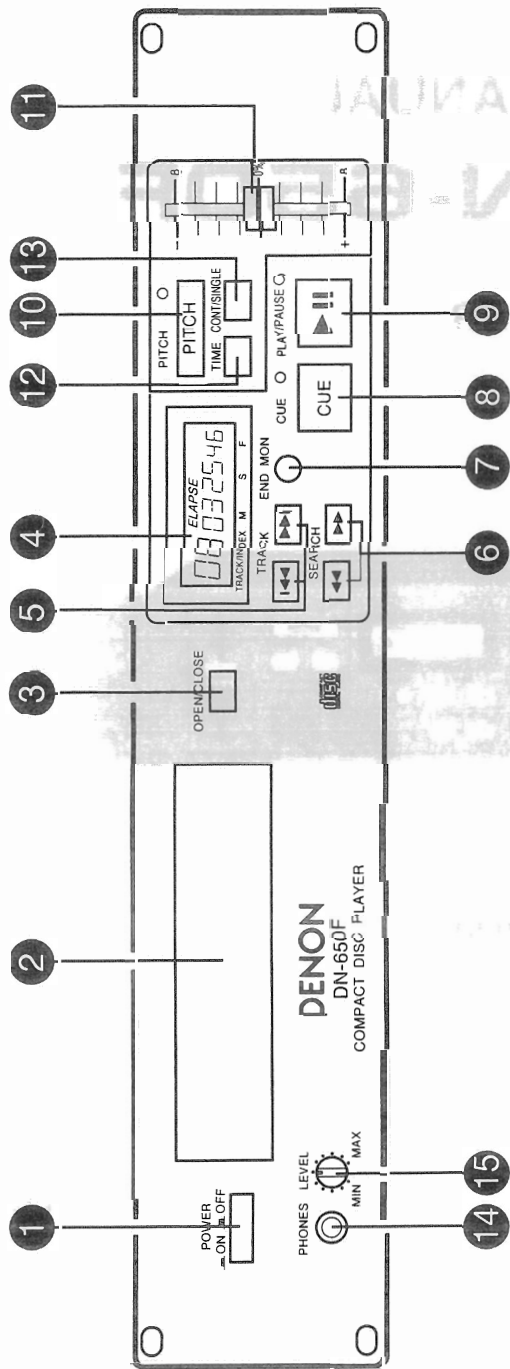

REAR PANEL
RÜCKWAND
PANNEAU ARRIERE
PANEL TRASERO
BAKSIDA

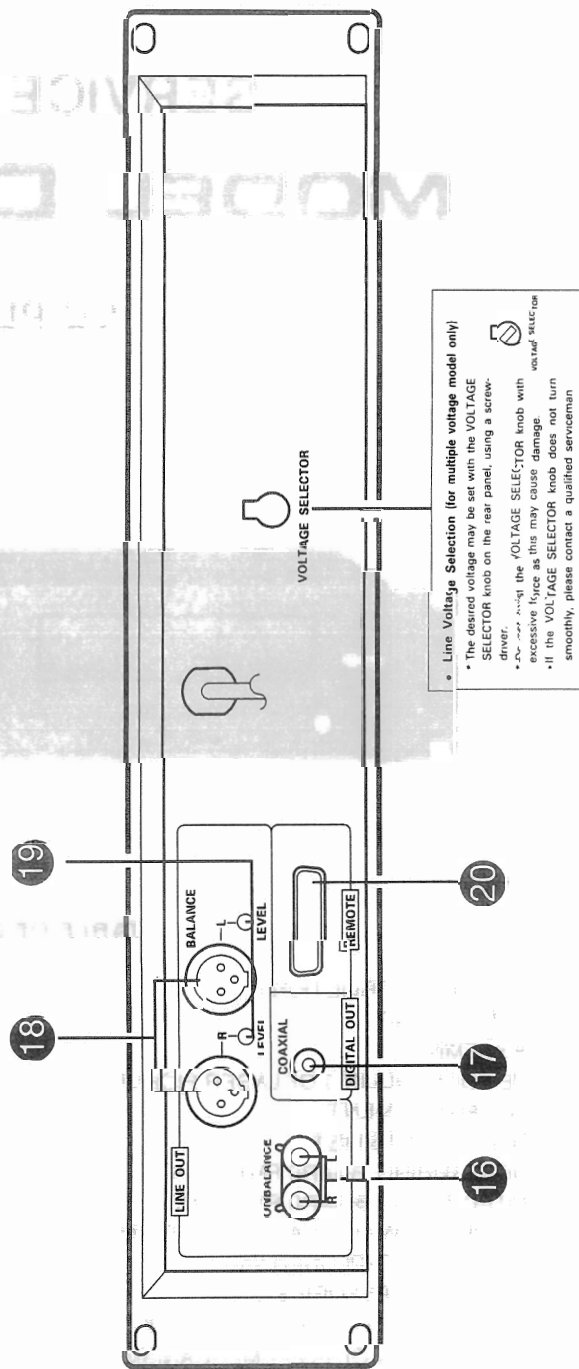

Line Voltage Selection (for multiple voltage model only)

- The desired voltage may be set with the VOLTAGE SELECTOR knob on the rear panel, using a screwdriver.
- Turn the VOLTAGE SELECTOR knob with excessive force, as this may cause damage.
- If the VOLTAGE SELECTOR knob does not turn smoothly, please contact a qualified serviceman.

1 PREPARATION

(1) Names, Dimensions and Functions of the Parts

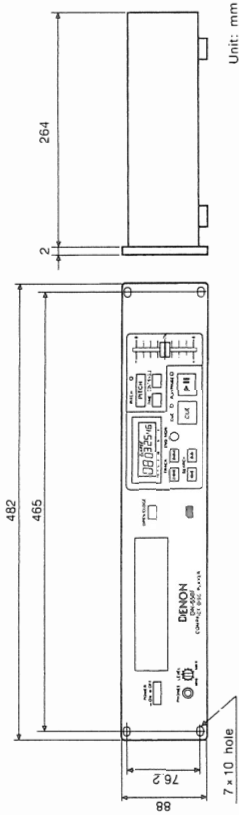

Figure 1

- 1 POWER (Power Switch)**
Switches the power of the unit.
- 2 Disc Holder**
The disc is placed on this holder. Pressing the disc holder open/close button 3 will open and close the holder. When loading the CD, place it securely in the disc holder.
- 3 OPEN/CLOSE (Disc Holder Open/Close Button)**
Press to load or eject the disc. Each press will open or close the disc holder 2.
- 4 Time Display**
This display shows the track or index number, time and elapsed or remaining time. Each frame represents 1/75 of a second.
- 5 TRACK (Track Button)**
This button selects the track or index to be played. Refer to Page 11, 15.
- 6 SEARCH (Search Buttons)**
These buttons are used to accurately change the positions where disc play will start. Refer to Page 14.
- 7 END MON (End Monitor Button)**
This button is pressed during the standby mode to play the last section of the track. Refer to Page 15.
- 8 CUE (Cue Button)**
Pressing the CUE button during play provides a return to the position at which play was started. Pressing the PLAY/PAUSE button and the CUE button alternatively allows the CD to be played from the same position any number of times. The red CUE LED will blink from the time the CUE button is pressed until the CD has reset to the position at which play was started. Steady lighting of this LED indicates the ready condition. Refer to Page 13.
- 9 PLAY/PAUSE (Play/Pause Button)**
Each press of the PLAY/PAUSE button causes the operation to change from play to pause or from pause back to play.
- 10 PITCH (Pitch Button)**
This button changes the play speed. The pitch can be changed up to $\pm 8\%$ by pressing the PITCH button so the green PITCH LED blinks when moving the sliding fader. When the play speed is set to a value other than 0% with the preset function, the PITCH LED will light steadily to indicate that speed control is not possible from the pitch slider. Refer to Page 14.
- 11 Pitch Slider**
Use this slider to adjust the playback speed. Slide up to decrease the speed, down to increase the speed. Refer to Page 14.

12 TIME (Time Button)

The TIME button switches the time display between elapsed time and remaining time. ELAPSE or REMAIN will be shown on the display.

13 CONT/SINGLE (Play Mode Button)

This is for switching the play mode between the single track mode (SINGLE) and continuous play mode (CONT.). Refer to Page 11.

14 PHONES (Headphones Jack)

Connect headphones with an impedance of 30 to 40 ohms.

15 Volume Control (PHONES LEVEL)

Use this to adjust the output level of the headphones.

16 LINE OUT (Output Jacks)

The audio is output from these jacks. Red is for the right channel and white the left channel.

17 DIGITAL OUT (Digital Output Jack)

This jack outputs digital data. We recommend using a 75-ohm pin cord (available in stores) for connections.

18 LINE OUT L/R (Output Connectors)

These are active balanced type outputs using XLR type connectors. Connect them to balanced type inputs with an impedance of 600 ohms on an amplifier or console.

19 Signal layout

- Pin 1 : Common
 - Pin 2 : Cold
 - Pin 3 : Hot
- 3) Applicable connector: Cannon XLR-3-11C or the equivalent
NOTE: Do not short-circuit the hot or cold pin with the common pin.

(2) Installation Precautions

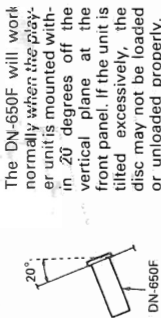

Figure 2

20 LEVEL L/R (Output Level Controls)

These adjust the level of the audio signals output from the LINE OUT L/R 18 connectors.

21 REMOTE (Remote Control Connector)

- 1) This is a connector for parallel remote connection.
- The player can be controlled remotely with a dry contact circuit connection.
- 2) Applicable connector: 25-pin D-sub plug
- 3) Signal layout Refer to Page 19

Pin No.	Signal	I/O	Level
1	FG	-	
2	PLAY TALLY	0	TTL (0-48 mA)
3	PAUSE TALLY	0	HC MOS (I _L -3 mA)
4	PAUSE COMMAND	0	TTL (0-48 mA)
5	CUE TALLY	0	HC MOS (I _L -3 mA)
6	CUE COMMAND	0	TTL (0-48 mA)
7	INDEX 2/3 TALLY	0	HC MOS (I _L -3 mA)
8	INDEX 2/3 COMMAND	0	TTL (0-48 mA)
9	NC	-	
10	TRACK (-) COMMAND	1	HC MOS (I _L -3 mA)
11	NC	-	
12	SEARCH (FWD) COMMAND	1	HC MOS (I _L -3 mA)
13	NC	-	
14	SEARCH (REV) COMMAND	1	HC MOS (I _L -3 mA)
15	NC	-	
16	FADER START	1	HC MOS (I _L -3 mA)
17	TALLY POWER SUPPLY	0	+5V, 20 mA
18	COMMAND COMMON	0	
19	COMMAND COMMON	0	
20	NC	-	
21	E.O.M./INDEX 2/INDEX 3	0	
22	NC	-	
23	E.O.M./INDEX 2/INDEX 3	0	
24	NC	-	
25	E.O.M./INDEX 2/INDEX 3	0	
26	NC	-	
27	NC	-	

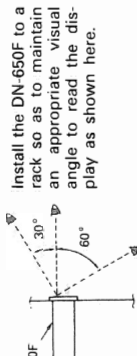

Figure 3

2 DESCRIPTION OF THE FUNCTIONS

The DN-650F is provided with special functions which are not available in common CD player. Please read the following explanation carefully before using these functions.

- (1) **Automatic Cueing**
Automatic cueing automatically searches for sound levels which are above the preset cue detect level following track selection and sets the cue mode. This function can skip a blank portion at the beginning of a track. See Page 17.
- (2) **Instant Start/Delayed Start**
The audio starts up within 0.01 seconds with a press of the play button. This provides an accurate start since there is no sound delay. A delayed start is also possible. The duration of the delay can be selected. See Page 17.
- (3) **Fade In**
There will be a fade in of the sound over the selected duration when playback is started. See Page 18.
- (4) **EOM (End Of Message)**
The EOM function causes the LCD to blink as an indication that the end of the playback is approaching when the remaining time of the playback reaches the preset time. Note that this unit may have a time deviation of 2 to 3 seconds duration. See Page 18.
- (5) **End Monitor**
This function plays the end portion of a track. The length of playback can be selected. See Page 18.
- (6) **Single/Continuous Play Mode**
Playback finishes at the end of the selected track in single play mode, whereas, playback continues to the end of the disc in continuous play mode. This function can be switched with the button or one of these modes can be preset after the power is switched on. See Page 11.
- (7) **Presettable Playback Speed**
The playback speed can be fixed to a preset speed in the range of 0 to +3% of the regular speed. When this speed is preset to a speed other than 0%, speed adjustment is not possible with the pitch slider. At this time the PITCH LED will be lit steadily. See Page 18.
Even if the pitch slider is mistakenly moved, the preset speed will not change.

The unit also has a variety of other functions. Please carefully read Section 4 PRESET FUNCTIONS on Page 16, 17, 18 and select the desired functions.

3 OPERATION

(1) **Loading and Ejecting the Disc**

- ① Open the disc holder.
- ② When the disc holder is closed, press the OPEN/CLOSE button to open the disc holder.
- ③ Place a disc in the disc holder

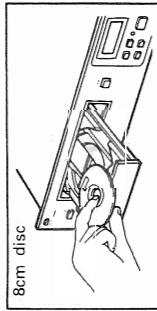
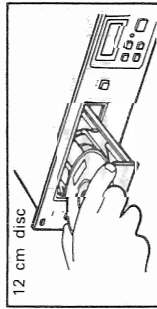

Figure 4

(2) **Selecting Tracks**

- ③ Loading the disc
Press the OPEN/CLOSE button to close the disc holder.
 - A press of the PLAY/PAUSE button will close the disc holder and start playback.
 - When a track is selected while the disc holder is open, the unit will access the selected track.

(2) **Selecting Tracks**

To go back through the tracks

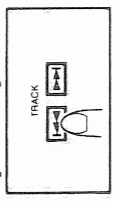

Tracks change as follows
(This is for a disc containing 4 tracks.)

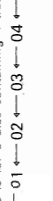

To advance through the tracks

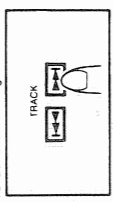

Tracks change as follows



Figure 5

(3) **SINGLE/CONTINUE Play Mode Selection**

- Press the CONT/SINGLE button to set DN-650F for SINGLE track playback mode, " S " is displayed on TRACK section.
- During single playback mode, DN-650F stops after a specified track is played back.
- Press the CONT/SINGLE button to set DN-650F for continuous playback mode, " C " is displayed on TRACK section.
- During continuous playback mode, DN-650F continue playback until completion of playback of the last track on the disc.

Each press of the TRACK button changes 1 track. Continuing to hold the TRACK button down provides an automatic change at a higher speed which is convenient for discs that contain many tracks. During the track selection operation, the track indication of the display will blink and the Minute, Second, Frame indication will be off. When a new track is selected during play, after the selection operation is completed, play will immediately start from the beginning of the newly selected track. The track number can be selected before loading a disc on DN-650F. You can select a track to play, then load a disc. DN-650F will cue up to your selected track automatically.

(4) Starting Playback

Pressing the PLAY/PAUSE button during the pause condition or after the completion of back cue will start disc play.

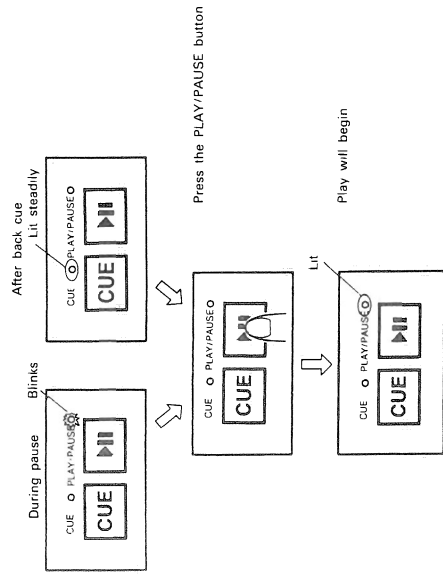
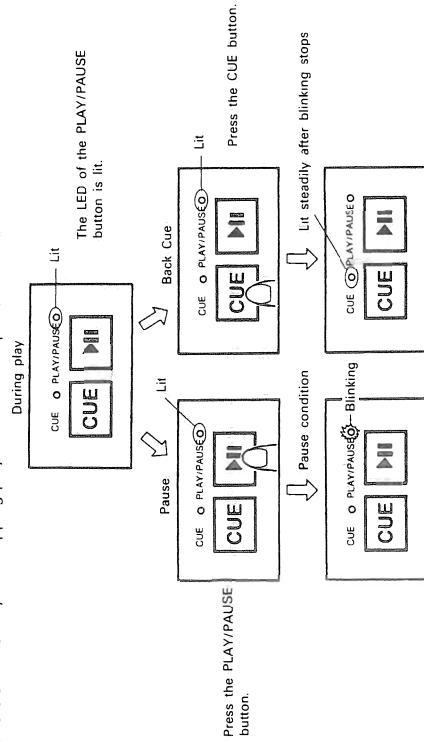

Figure 6

(5) Stopping Playback

There are two ways of stopping play. One uses the pause function and the other the back cue function



The LED of the PLAY/PAUSE button blinks. (The CD pauses at the position where the PLAY/PAUSE button was pressed during play.)

Back cue operation
First the LED of the CUE button blinks, then it lights steadily after the operation is completed.
(The CD returns to the position where play back started from.)

Figure 7

(6) Description of the PLAY/PAUSE, and CUE Operations

- Each press of the PLAY/PAUSE button causes the operation to change from play to pause or from pause back to play.
 - The play operation of this CD player is performed via DSP (Digital Signal Processor) and memory, so the audio starts instantly after the PLAY/PAUSE button is pressed.
 - Pressing the CUE button during disc play resets the CD to the position at which play was started. (This is called the back cue function.)
- The steps through which disc play is performed when the PLAY/PAUSE and CUE buttons are pressed are described with the aid of the following illustrations in Figures 8 through 10.

① PLAY and PAUSE

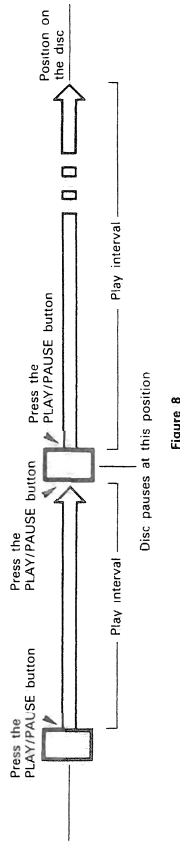

Figure 8

Pressing the PLAY/PAUSE button starts the disc play (Operation progress is shown by the arrows of Figure 8). Pressing the PLAY/PAUSE button again during disc play causes the play operation to pause, and pressing this button once more causes the disc to be played again.

② PLAY and CUE

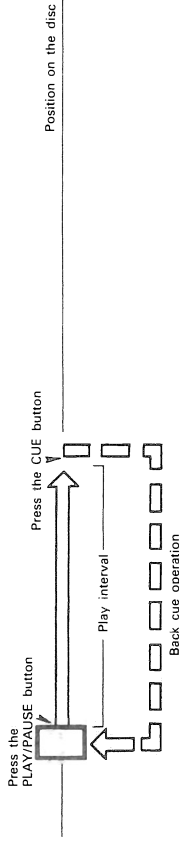

Figure 9

Pressing the PLAY/PAUSE button starts the disc play. Pressing the CUE button will reset the disc to the position where play was started. By alternately pressing the PLAY/PAUSE button and the CUE button, the disc may be played from the same position any number of times. This function is called back cue.

③ PLAY, PAUSE, and CUE

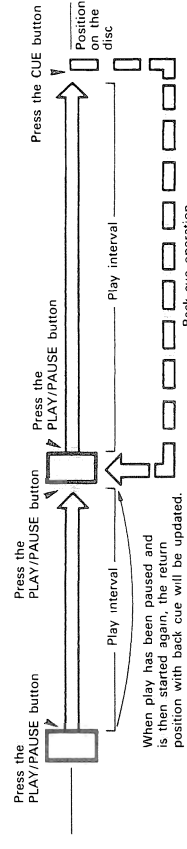

Figure 10

(7) **Adjusting the Speed**

- Press the **PITCH** button to enable the speed to be adjusted with the pitch slider.
- The **PITCH** LED will blink to indicate that a pitch adjustment can be made.
- Pressing the **PITCH** button once again will light the **PITCH** LED and set that pitch.
- Pressing the **PITCH** button one further time will cause the **PITCH** LED turn off and the variable pitch function will switch off.
- Lowering the position of the pitch slider will increase the pitch and raising the position will decrease the pitch

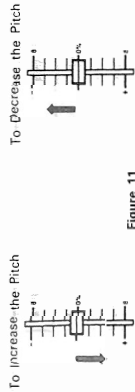

Figure 11

Operation of the pitch slider will not change the speed when the preset playback speed is set to a value other than 0%.
NOTE: Be sure to set the **PITCH** button to the off condition when normal speed has been set.

(8) **Searching**

When a track is selected and the **PLAY/PAUSE** button is pressed, the play operation will start from the beginning of that track. However, when you want play to start from a different position, use the following procedure to find that position.

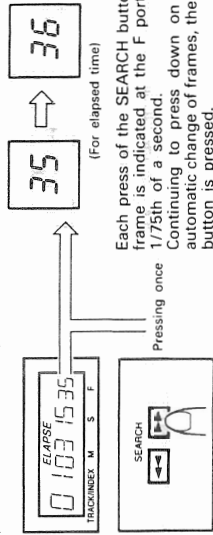

Figure 12

(9) **Checking the Play Start Position**

After selecting the track or after changing the play start position with the **SEARCH** button, use the following procedure to repeatedly check the position at which play will start.

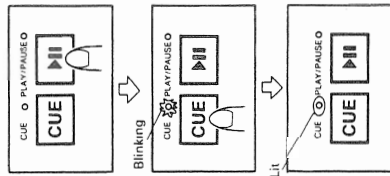

Figure 13

Press the **PLAY/PAUSE** button.
 Check that play will start from the desired position.

NOTE:
 Once you have set up a new start position within a track, do not press the **PLAY/PAUSE** or **SEARCH** buttons. Pressing these buttons will change your start position.

Press the **CUE** button after checking the start position.

The player will return to the position where play was started. When the **CUE** LED stops blinking, it is ready to start again.

If the play start position is not to your liking, use the search function to change the position.

(10) **End Monitor**

The end section of a track can be played at the touch of a button.
 This function comes in very handy to check how the track ends.

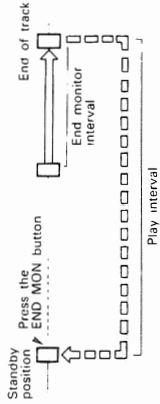

In the **CUE** mode
 The **CUE** button is lit

Press the **END MON** button

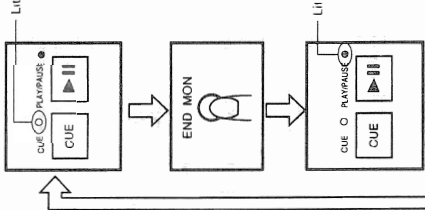

When playback ends, the pickup returns to the standby mode is set.

Figure 14

The end of the track at which the **CUE** mode is set is played.
 Play time: 0 to 35 seconds in 5-second steps can be presetting. (refer to on page 18)

(11) **Ending Playback**

The operation that follows the playing of the disc to the end in the continuous play mode can be selected from among the following three operations. See page 17.

- ① **Recue**
 The player returns to the playback start position and the cue mode is set.
- ② **Next track**
 The player moves to the next track and the cue mode is set.
- ③ **Stop**
 The **PLAY/PAUSE** LED blinks, the time display turns off, and the player stops. While the player is stopped, only the **TRACK +/-** button and the **OPEN/CLOSE** button are effective.

(12) **Selecting Indexes**

When the preset index search is set to on, the index number is displayed as **TRACK/INDEX** and the index can be selected with the **TRACK +/-** button. The operation procedure is the same as that in Section (2) **Selecting Tracks**.

Note:
 Track selection is not possible when the preset index search is set to on. To select a track, reset the index search to off.

4 PRESET FUNCTIONS

The DN-650F is equipped with non-volatile memory and is able to store various preset data. These data will not be lost even if the power is cut and so the desired settings corresponding to items such as those described in the table of Page 17, 18 can be stored to memory. Please use this function and operate the player at the optimum settings.

(1) Starting the Preset Data Change Mode

- Open the disc holder.
- Press the TIME button and the CONT./SINGLE button at the same time. The DN-650F will enter the preset data change mode and the first preset data will be displayed. The preset item number is displayed in the track display area and the current data are displayed in the minutes and seconds display area.

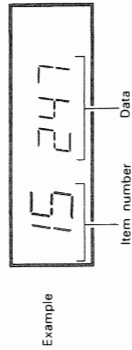

Figure 15

(2) Selecting the Item Number

- Press the TRACK + button to increase the item number.
- Press the TRACK - button to decrease the item number.
- The data of the selected item are displayed.

(3) Changing the Preset Data

- Press the SEARCH +/- button to select the preset data. The display data will change and blink.
- When the appropriate data have been selected, press the CUE button and store the data to the non-volatile memory.
- The display data will stop blinking.
- To change other items, repeat the operations of Steps (2) and (3).

(4) Initializing the Preset Data

- To initialize the preset data to the factory setting, store 1 to the data of item 0.
- The factory setting data are indicated by asterisks in the table of Page 17, 18.

(5) Exiting the Preset Data Change Mode

To complete the change and return to the normal mode, press the TIME button and the CONT./SINGLE button at the same time or press the OPEN/CLOSE button.

(6) Table of Preset Functions

The "*" mark indicates setting upon shipment from the factory.

ITEM	DISPLAY			DESCRIPTION
	TRACK	MINUTE	SECOND	
Initialize	0 0		0	* No operation Initialize to the same data as the factory setting.
Stereo/Mono	0 1		0	* L/R stereo signal output * L/R signal output mixed.
Frame Display	0 2		0	Off Frame is not displayed during playback. On Frame is displayed during playback.
Display Mode when Power Turned On	0 3		0	Elapse * Elapsed time is displayed when power turned on. Remain * Remaining time is displayed when power turned on.
Play Mode when Power Turned On	0 4		0	Single * Playback ends at the end of track Continue * Playback continues until the end of disc.
Play Lock	0 5		0	Off * All button functions during playback. On Buttons except the TIME, CONT./SINGLE, PLAY/PAUSE don't function during playback.
Digital Out	0 6		0	With subcode * Digital signal outputs with subcode ... ① Without subcode* * Digital signal outputs without subcode ... ②
Index Search	0 7		0	Off * Track, Minute, Second, Frame are displayed. On Track is selected with TRACK buttons. * Track, Minute, Second, Frame are displayed. Index is selected with TRACK buttons.
Tally Flash	0 8		0	No Flash * The PLAY, PAUSE, and CUE lallies in the REMOTE connector will remain off instead of blinking. Flash * When the REMOTE connector is connected, the corresponding LEDs of front panel blink.
Index 2/3	0 9		2	Index 2 Tally output from REMOTE connector pin 17. Index 3 * Index 3 Tally output from REMOTE connector pin 17.
EOM/Index	1 0		1	EOM * EOM Tally output from REMOTE connector pins 24 and 25. Index 2 * Tally output from REMOTE connector pins 24 and 25. Index 3 * Tally output from REMOTE connector pins 24 and 25.
Fader Start Mode	1 1		0	Start Only * Player starts when fader switch turned on. Start, Stop * When fader switch turned on, set to pause mode when fader switch turned off.
Ending Playback	1 2		0	Recue * When playback ends, player returns to the started position. Next Track * When playback ends cue mode is set at the next track. Stop * Stop mode is set when playback ends.
Delay Start	1 3		0	0msec * Audio start will be delayed by the selected time setting. 100msec 200msec 300msec
Cue Detect Level	1 4		-∞	-∞ -72dB -60dB -54dB -48dB -42dB -36dB * In the cue operation following track selection, audio signals above the set level are automatically searched and cued at that point.

① Data other than audio data such as sub codes will be output with regular values, but the cue detect level and the fade in duration will not be the preset values, rather -∞ and 0 ms, respectively. Also, the audio start time will be 300 ms or less.
② The cue detect level and the fade in duration will be the preset values. Data other than audio data such as sub codes will be "0"

5 REMOTE CONTROL CONNECTIONS

To control the DN-650F remotely, refer to the example of remote control connections given below.

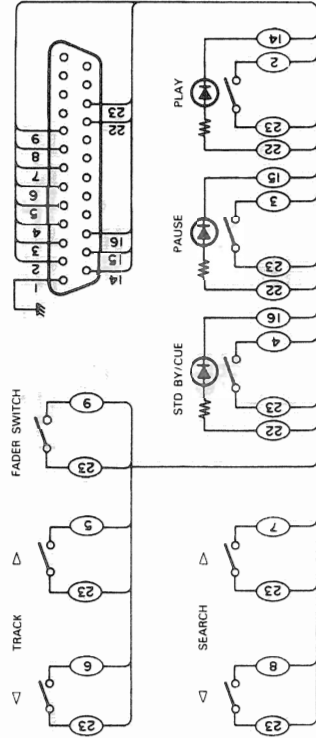

Figure 16

The rating of REMOTE connector pin 22 (TALLY POWER SUPPLY) is +5 V, 20 mA maximum. Avoid currents in excess of the rating.

6 BEFORE SWITCHING OFF THE POWER

When you have finished using the CD player, before switching off the power be sure that the disc holder has been closed with the OPEN/CLOSE button.

CAUTION:

Do not forcibly close the disc holder when the power is off. It may damage the unit when it is transported.

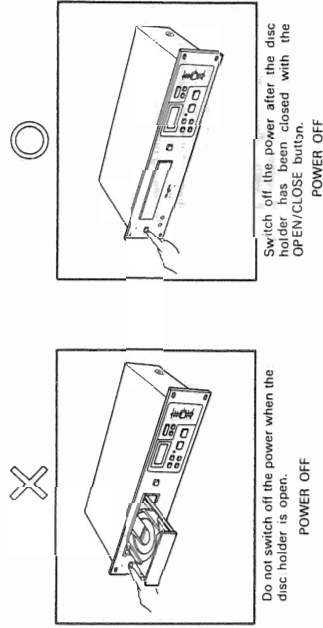

Figure 17

ITEM	DISPLAY		DESCRIPTION
	TRACK	MINUTE SECOND	
Fade In Duration	1 5	0	0msec * No fade in
		1 0	10msec
		3 0	30msec
		5 3	53msec
		8 6	140msec
		1 4 8	185msec
		1 8 5	247msec
EOM Duration	1 6	0	EOM not output
		1 5	5sec
		1 5	10sec
		2 0	15sec
		2 0	20sec
		3 0	30sec
		3 5	35sec
End Monitor Duration	1 7	0	End Monitor does not function
		1 5	5sec
		1 5	10sec
		2 0	15sec
		2 5	20sec
		3 0	25sec
		3 5	35sec
Preset Playback Speed	1 8	0	Standard * Speed adjustment is possible from the front panel
		2	-0.2%
		4	-0.4%
		6	-0.6%
		8	-0.8%
		1 0	+1.0%
		1 2	+1.2%
		1 4	+1.4%
		1 6	+1.6%
		1 8	+1.8%
		2 0	+2.0%
		2 2	+2.2%
		2 4	+2.4%
2 6	+2.6%		
2 8	+2.8%		
3 0	+3.0%		

7 COMPACT DISCS

1. Precautions on handling compact discs
 - Do not allow fingerprints, oil or dust to get on the surface of the disc.
 - If the disc is dirty, wipe it off with a soft dry cloth.
 - Do not use benzene, thinner, water, record spray, electrostatic-proof chemicals, or silicone-treated cloths to clean discs.
 - Always handle discs carefully to prevent damaging the surface; in particular when removing a disc from its case or returning it.
 - Do not bend the disc.
 - Do not apply heat.
 - Do not enlarge the hole in the center of the disc.
 - Do not write on the label (printed side) with a hard-tipped implement such as a pencil or ball point pen.
 - Condensation will form if a disc is brought into a warm area from a colder one, such as outdoors in winter. Do not attempt to dry the disc with a hair dryer, etc.
2. Precaution on storage
 - After playing a disc, always unload it from the player.
 - Always store the disc in the jewel case to protect from dirt or damage.
 - Do not place discs in the following areas:
 - 1) Areas exposed to direct sunlight for a considerable time.
 - 2) Areas subject to accumulation of dust or high humidity.
 - 3) Areas affected by heat from indoor heaters, etc.

8 TROUBLESHOOTING

When you think the player might be broken, please check the following items.

- The disc holder does not open or close.
- Is the power switch set to ON?
 - Is the player in the process of playing a disc? See page 11
 - The display still indicates "—" when a disc is loaded.
 - Is the disc loaded properly?
 - Is the disc dirty or scratched?
- There is no sound or the sound is distorted.
- Are the output cables connected to the amplifier correctly?
 - Is the adjustment of the amplifier's controls and switching correct?
 - Is the disc dirty or scratched?
- There is a button that doesn't function.
- Has a preset such as PLAY-LOCK been set? See Page 17.

9 SPECIFICATIONS

GENERAL	CD Player
Type	Standard Compact Discs (12cm, 8cm/5", 3")
Disc Type	
AUDIO SECTION	
Channels	2 Channels Stereo
Sampling Frequency	44.1kHz at Normal Pitch
Quantization	16-bit Linear/Channel
Oversampling	8-times, 18-bit
Frequency Response	20Hz - 20kHz
Total Harmonic Distortion	0.008% or less
Signal to Noise Ratio	95dB or more
Channel Separation	90dB or more
Unbalanced Output	RCA Jack
Output level	2.0V at 0dB Disc
Load Impedance	10k ohm or more
Balanced Output	3-Pin XLR (Active Balanced)
Output Level	+18dBm at 0dB Disc (Active Balanced)
Output Adjust Range	+18dBm to -20dBm or more
Load Impedance	600 ohm
Digital Output	Coaxial (RCA Jack)
Headphone Output	Stereo
Output level	20mW or more
Load Impedance	30 to 40 ohm
Variable Pitch Control	±8% max
Audio Start-up Time	0.01 second or less
Frame Search Accuracy	1/75 second
DIMENSIONS	
	482 (W) × 88 (H) × 266 (D) mm
	19" (W) × 3-15/32" (H) × 10-15/32" (D)
	excluding height of keys, connectors and feet
	Approx. 4.5kg
WEIGHT	Approx. 14W
POWER CONSUMPTION	
POWER SUPPLY	AC120V ±10%, 60Hz (USA, Canada)
	AC230V ±10%, 50Hz (Europe, Others)
	AC115/230V ±10%, 50/60Hz (Asia, Others)
	UL (USA)
	CSA (Canada)
SAFETY STANDARD	
ENVIRONMENTAL CONDITIONS	
Operating Temperature	+5°C to 35°C
Humidity	25% to 85%, Non Condensing
Storage Temperature	-20°C to 60°C
REMOTE	
	Parallel Remote, D-sub 25 pin connector

* Specifications and design are subject to change without notice for purpose of improvement.

DISASSEMBLY

● TOP COVER

Remove 4 screws from both sides and 1 screw from Back Panel.

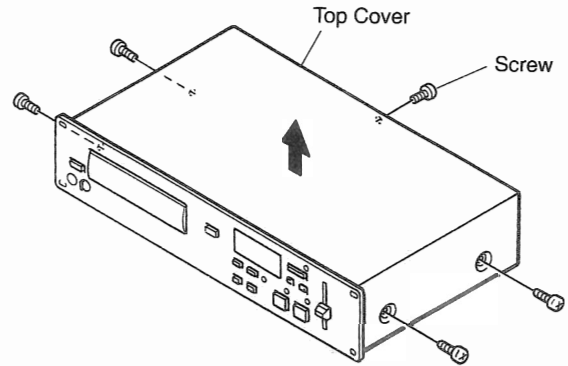

● FRONT PANEL

1. Pull Loader Frame frontward, and remove Loader Panel.
2. Remove 2 Front Panel upper screws.
3. Remove 2 Front Panel lower screws.
4. Undo 2 front panel upper hooks.
5. Pull Front Panel and undo a lower hook.

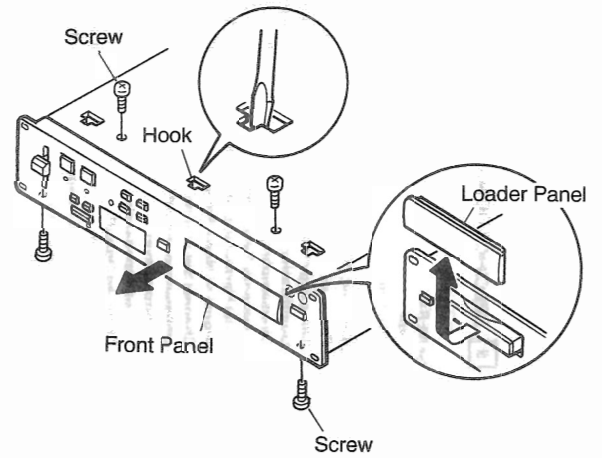

● MECHANISM UNIT

Remove 4 screws.

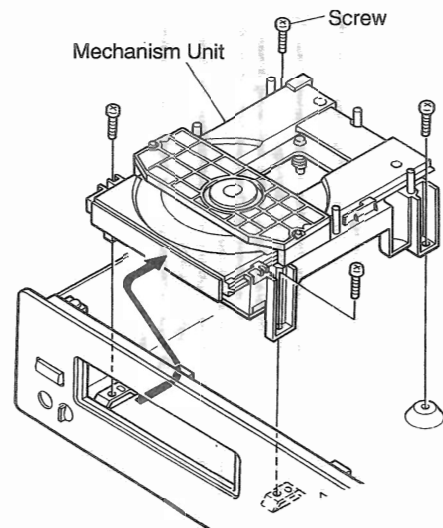

● CLAMPER

Remove 2 screws.
Pull clamper and undo 4 hooks.

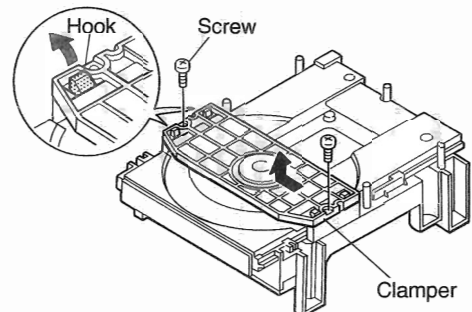

NOTE FOR HANDLING OF LASER PICK-UP

DESCRIPTION OF THE COMPONENTS

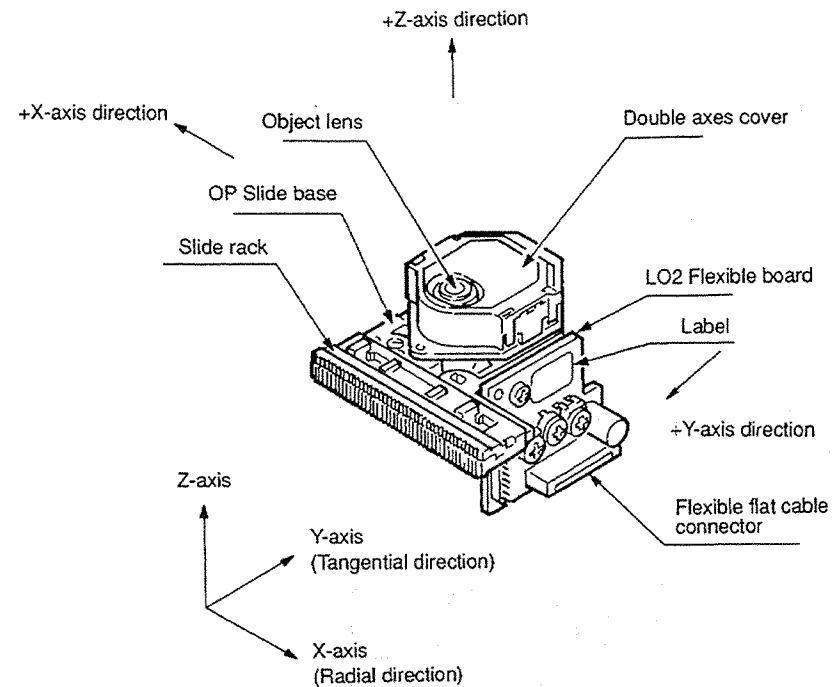

LABEL

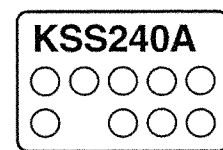

Lot No.
Top

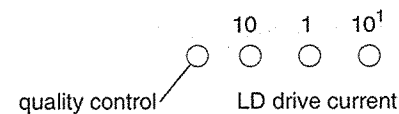
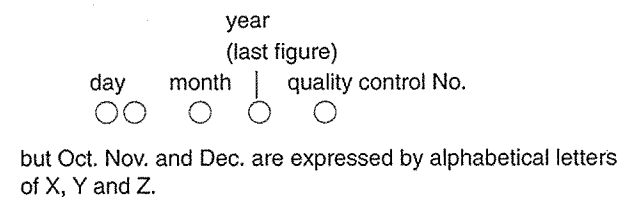

The expressed unit is by mA, with omission of the decimal point as for example, 56.5mA will be expressed as 565, but the head of English letter means the control in the manufacturing plant.

PIN CONNECTOR

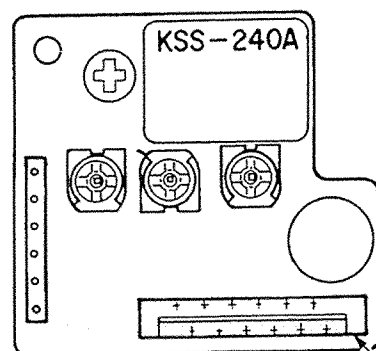

1 3 5 7 9 11
2 4 6 8 10 12

Flexible flat cable connector

Pin No.	Description	Input/Output	Pin No.	Description	Input/Output
1	VC (+2.5V)	OUT	7	Vcc (+5V)	IN
2	TE (TRK ER signal)	OUT	8	LDC (LD Control)	IN
3	FE (FCS ER signal)	OUT	9	FCS+ (Double axes)	IN
4	FZC (FZC signal)	OUT	10	TRK+ (Double axes)	IN
5	RF (RF signal)	OUT	11	TRK- (Double axes)	IN
6	GND	IN	12	FCS- (Double axes)	IN

Caution for Handling the Laser Pick-up

The laser pick-up KSS-240A is assembled and precisely adjusted using a sophisticated manufacturing process in our plant. Do not disassemble or attempt to readjust it. Please keep the following instructions carefully in handling pick-up.

1. Handle with Care

- (1) Storage
Do not store the pick-up in dusty, high-temperature or high-humidity environments.
- (2) Please take care for preventing from shock by falling down or careless handling.

2. Laser Diode (LD)

- (1) Protect your eyes
The laser beam may damage the human eye, since the intensity of the focused spot may reach $7 \times 10^3 \text{ W/cm}^2$ even if the intensity at the objective lens is $400 \mu\text{W}$ maximum. As the light beam spreads after focused through the objective lens, it does not effect you in the place as far as more than 30 cms. However, do not look at the laser light beam either through the objective lens directly nor another lens or a mirror.
- (2) Poison of As
Since the LD chip contains As (Arsenic), as GaAs + GaAlAs, as known as the poison, although the poison is relatively weak, in comparing with others, e.g. As₂O₃, AsCl₃ etc., and the amount is small, avoid putting the chip in acid or an alkali solution, heating it over 200°C or putting it into your mouth.

(3) Avoid surge current or electrostatic discharge

The LD may be damaged or deteriorated by its own strong light if a large current is supplied to it, even if only a short pulse.

Make sure that there is no surge current in the LD driving circuit by switches or else. Be careful to handle pick-up as it may be damaged in a moment by human electrostatic discharge. The pins of the LD are short-circuited by solder for protection during shipment.

For safety handling of an LD, grounding the human body, measuring equipments and jig is strongly recommended. And still it is further desirable to make use of mat on the platform and floor for handling the LD.

To open the short-circuit, remove the soldering quickly with a soldering iron whose metal part is grounded.

The temperature of the soldering iron should be less than 320°C (30W).

3. Actuator

- (1) The performance of the actuator may be effected if magnetic material is located nearby, since the actuator has a strong magnetic circuit. Do not permit dust to enter through the clearance of the cover.

(2) Cleaning the lens

It may change the specifications by attaching dust or ash on the objective lens. Clean the lens with a cleaning paper dampened with a little water, not pressing lens with so much strength by the cleaning paper.

4. Metal Bearing

As the metal bearing of Cu-compound sintered alloy is impregnated with FROIL946P (*Part No. 529 0054 007), never fail to supply the bushing with the same lubricant at the time of replacing the pick-up.

5. Handling

Please handle the laser pick-up with holding the side base (rosin molded part).

When either a part of human body or some other things may happen to touch directly with the circuit part of P.W.Board, it may cause deterioration, take careful attention in handling this base.

6. Deterioration

As KSS-240 comprises built-in RF Amp and APC circuit, it resists stronger against external electrostatic damages than the former typed pickup. However, there is possibility of pickup deterioration in the following cases.

- (1) Low HF level, or with great numbers of jitters.
- (2) Tracking offset (EF Balance) is out of order (Refer to "Confirmation Method of Adjustment " for confirmation on (1) and (2)).

SERVO ADJUSTMENT

NECESSARY EQUIPMENTS FOR ADJUSTMENT

1. Dual trace oscilloscope
2. Reference disc CA1094
3. Frequency Counter
4. Filter for measurement

LOCATION

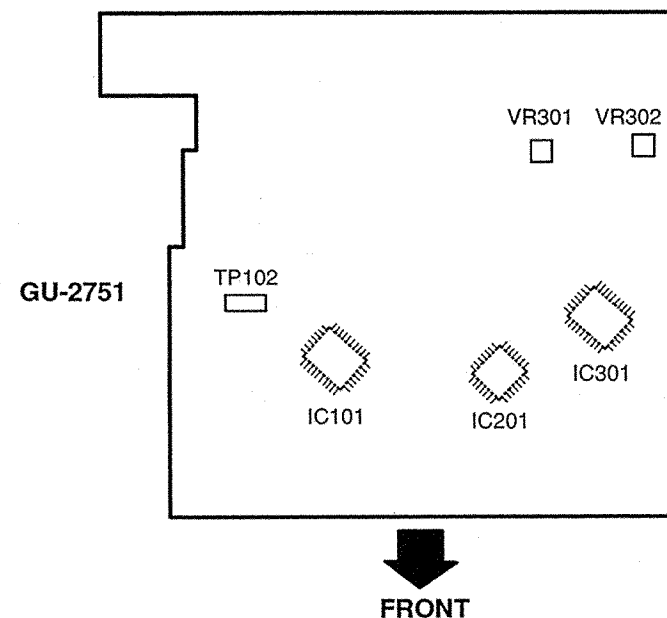

ADJUSTMENT PROCEDURE

Be sure to perform servo confirmations by this order.

1. Actuating the Service Program.
2. Confirmation of Tracking Offset.
3. Confirmation of HF Waveform.

1. ACTUATING THE SERVO PROGRAM

- ① Turn the power off.
- ② While simultaneously pushing the SEARCH buttons (◀▶) and the TRACK (▶▶) button, turn the power on.
- ③ Displayed indication is version number of microcomputer program 4 figures.

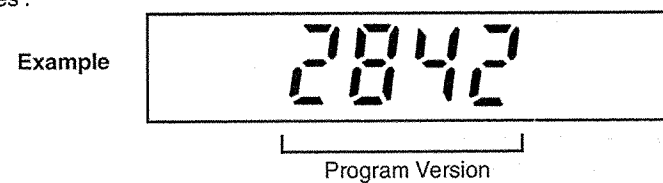

- ④ Push the TRACK (▶▶) button of the mechanism intended to confirm for one time. After confirm that 01 is displayed, push the PLAY button. Then, the Tray will open, set the disc.
- ⑤ Push the PLAY button. Then, the Tray will close.
- ⑥ Push the TRACK (▶▶) button (02 is indicated), then push the PLAY button.
- ⑦ Push the TRACK (▶▶) button (03 is indicated), then push the PLAY button.

2. CONFIRMATION OF TRACKING OFFSET

- ① Connections

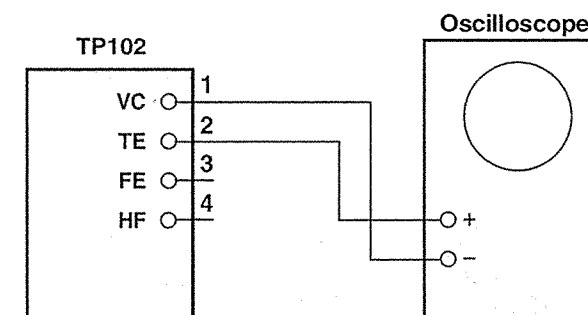

- ② Push the TRACK (▶▶) button (04 is indicated), then push the PLAY button.
- ③ Observe TE on the scope.

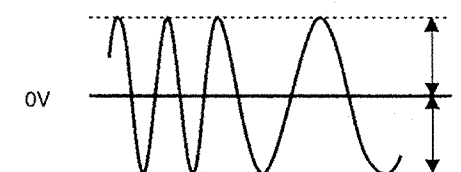

Measure the voltage of A,B and in case $\frac{|A-B|}{A+B}$ exceeds 15%, please replace pick-up as it is defected.

3. CONFIRMATION OF HF WAVEFORM

- ① Connections

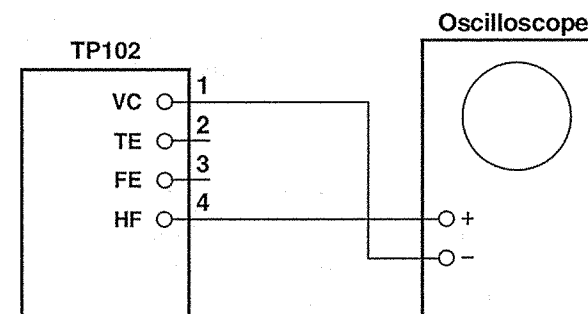

- ② Push the TRACK (▶▶) button (05 is indicated), then push the PLAY button.
- ③ Observe HF waveform on the scope.
- ④ The standard amplitude of HF waveform is 1.1V. If it is less than 0.8V, please replace pick-up as it is defected.

4. ADJUSTMENT OF SUPER LINEAR CONVERTER

Adjustment of Super Linear Converter is only performed at a time the DA Converter is replaced.

Adjustment Procedure

- ① Connections
Connect the LINE OUT to a distortion meter through the low-pass filter.
- ② Playback a disc obtains 1kHz, 0dB sine wave tone.
- ③ Adjust the RV301, RV302 and obtain minimum THD.

RV301. L-channel
RV302. R-channel

THD standard is less than 0.006%

ABOUT THE SERVICE PROGRAM

The service program is a program specially for servo confirmations.

ACTUATING THE SERVICE PROGRAM.

- ① Turn the power off.
- ② While simultaneously pushing the SEARCH buttons (◀▶) and the TRACK button (◀▶), turn the power on.
- ③ Program version of microcomputer indicated on the remote control signifies start actuating of service program.

CONTENTS OF SERVICE PROGRAM

After actuating the service program, select an aiming process number with the TRACK (◀▶) buttons, END MON button, and PITCH button, and push the PLAY button to execute processing, The process number is then displayed on the TRACK indication portion.

TRACK BUTTONS	Process No. (TRACK Indication)	Function	Contents Explanation
TRACK BUTTONS ◀▶	01	OPEN/CLOSE	Performs OPEN/CLOSE each time the PLAY button is pushed.
	02	FOCUS ERROR	Confirm FOCUS Error signal (S curve).
	03	FOCUS SERVO ON	Turns the FOCUS Servo ON.
	04	Confirmation of TRACKING OFFSET	Rotates the disc. Checks divergence of Tracking Offset.
	05	Confirmation of HF	Normally the same as PLAY MODE.
	06	Cleaning of Pick-up Lens	Pick-up. moves when SEARCH (◀▶) button is pressed. Move the pick-up under the hole of mechanism PWB, and clean the lens.
END MON	0A	CHUCKING Test	Repeats OPEN/CLOSE of tray, servo ON, and TOC read.
PITCH	0d	Heat Run	Repeats, OPEN/CLOSE of tray, repeats playing the first and the last programs of music on the disc. When an error occurs, displays error code and stops. (See the table below.)

Table of Error Code

Error Code	Contents
E0	Automatic adjustment of servo does not finish.
E1	Focus servo error. E1-00 No FOK is appeared. E1-01 FOK is appeared, but no FZC is shown. E1-02 Both FOK, FZC are appeared, but FZC is Shorter than mask time. E1-03 Both FOK, FZC are appeared, but FZC is not turned to "L" within prescribed time.
E2	Unable to detect sync pattern (GFS) however, rotating the disc. E2-00 FOK is turned to "L" after spindle kick. E2-01 GFS is not appeared.

E3	Unable to detect sync pattern (GFS). E3-00 In playing E3-01 in searching.
E4	Unable to read TOC when servo is actuated. E4-00 unable to read subcode. E4-02 Unable to read TOC within 15 seconds after finish reading subcode.
E5	Disc holder malfunction.
E6	Pick-up innermost circle switch does not turn OFF.
E7	Pick-up innermost circle switch does not turn ON.

NOTE FOR PARTS LIST

NOTE FOR PARTS LIST

- Part indicated with the mark " * " are not always in stock and possibly to take a long period of time for supplying, or in some case supplying of part may be refused.
- When ordering of part, clearly indicate "I" and "I" (i) to avoid mis-supplying.
- Ordering part without stating its part number can not be supplied.
- Part indicated with the mark "*" is not illustrated in the exploded view.
- Not including Carbon Film ±5%, 1/4W Type in the P.W.Board parts list. (Refer to the Schematic Diagram for those parts.)

WARNING:

Parts marked with this symbol have critical characteristics. Use ONLY replacement parts recommended by the manufacturer.

● Resistors

Ex.: RN 14K 2E 182 G FR
Type Shape and performance Power Resistance Allowable error Others

RD : Carbon	2B : 1/8W	F : ±1%	P : Pulse-resistant type
RC : Composition	2E : 1/4W	G : ±2%	NL : Low noise type
RS : Metal oxide film	2H : 1/2W	J : ±5%	NB : Non-burning type
RW : Winding	3A : 1W	K : ±10%	FR : Fuse-resistor
RN : Metal film	3D : 2W	M : ±20%	F : Lead wire forming
RK : Metal mixture	3F : 3W		
	3H : 5W		

* Resistance

1 8 2 ⇒ 1800 ohm = 1.8 kohm
Indicates number of zeros after effective number.
2-digit effective number.

• Units: ohm

1 R 2 ⇒ 1.2 ohm
1-digit effective number.
2-digit effective number, decimal point indicated by R.

• Units: ohm

● Capacitors

Ex.: CE 04W 1H 2R2 M BP
Type Shape and performance Dielectric strength Capacity Allowable error Others

CE : Aluminum foil electrolytic	0J : 6.3V	F : ±1%	HS : High stability type
CA : Aluminum solid electrolytic	1A : 10V	G : ±2%	BP : Non-polar type
CS : Tantalum electrolytic	1C : 16V	J : ±5%	HR : Ripple-resistant type
CO : Film	1E : 25V	K : ±10%	DL : For charge and discharge frequency
CK : Ceramic	1V : 35V	M : ±20%	HF : For assuring high frequency
CC : Ceramic	1H : 50V	Z : +80%	U : UL part
CP : Oil	2A : 100V	-20%	C : CSA part
CM : Mica	2B : 125V	P : +100%	W : UL-CSA type
CF : Metallized	2C : 160V	-0%	F : Lead wire forming
CH : Metallized	2D : 200V	C : ±0.25pF	
	2E : 250V	D : ±0.5pF	
	2H : 500V	= : Others	
	2J : 630V		

* Capacity (electrolyte only)

2 2 2 ⇒ 2200µF
Indicates number of zeros after effective number.
2-digit effective number.

• Units: µF.

2 R 2 ⇒ 2.2µF
1-digit effective number.
2-digit effective number, decimal point indicated by R.

• Units: µF.

* Capacity (except electrolyte)

2 2 2 ⇒ 2200pF = 0.0022µF
(More than 2) — Indicates number of zeros after effective number.
2-digit effective number.

• Units: µF.

2 2 1 ⇒ 220pF
(0 or 1) — Indicates number of zeros after effective number.
2-digit effective number.

• Units: pF.

• When the dielectric strength is indicated in AC, "AC" is included after the dielectric strength value.

PRINTED WIRING BOARD PATTERNS

1 2 3 4 5 6 7 8

GU-2751 MAIN UNIT

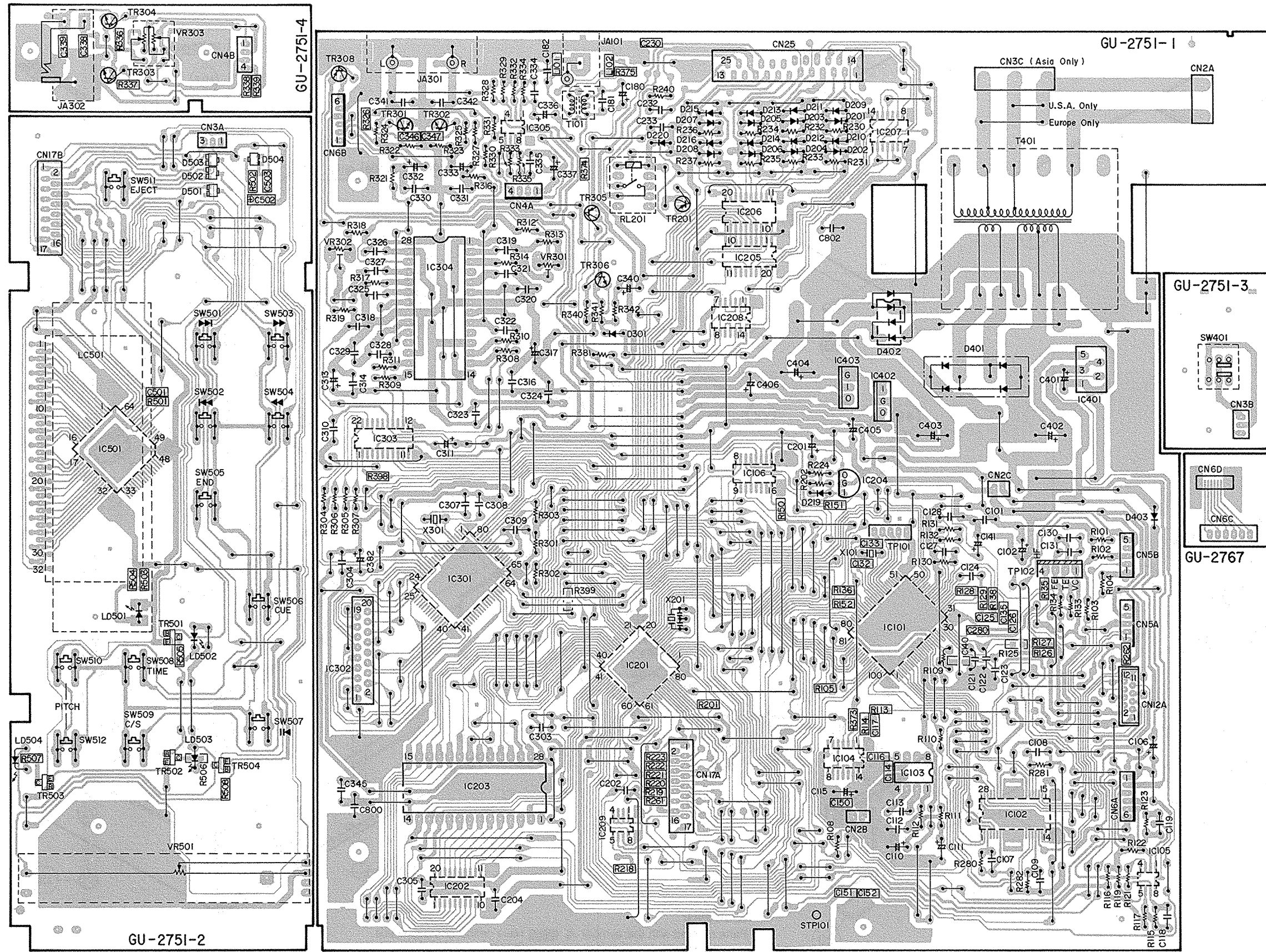

A
B
C
D
E

EXPLODED VIEW OF CHASSIS AND CABINET

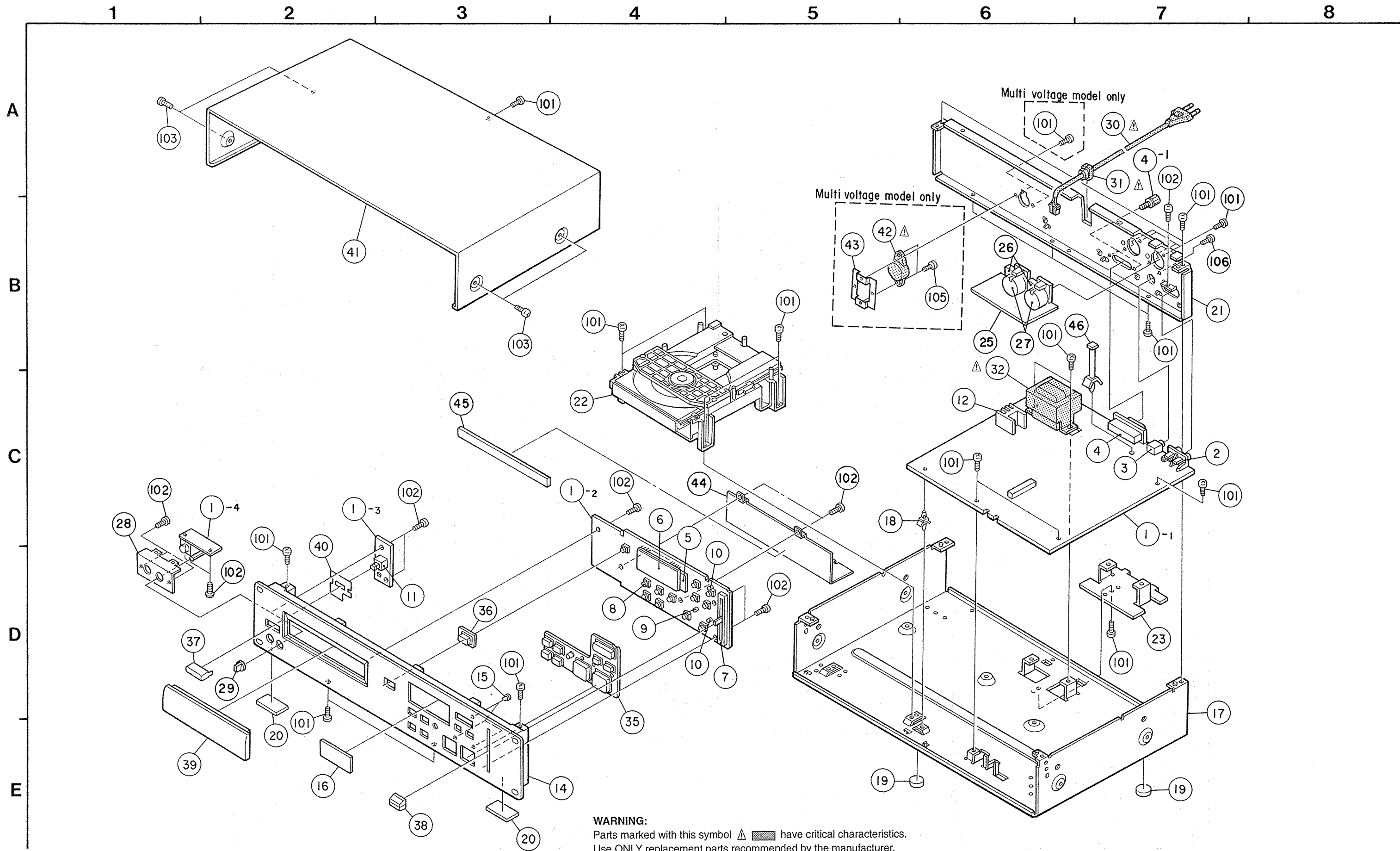

PARTS LIST OF EXPLODED VIEW

Ref. No.	Part No.	Part Name	Remarks	Q'ty	Ref. No.	Part No.	Part Name	Remarks	Q'ty
①	1	GU-2751	Main PWB Unit Ass'y	1	SCREWS				
	1-1		Main PWB Unit	1	101	473 7002 021	Tapping Screw 3×8(S)	Black	24
	1-2		Panel PWB Unit	1	102	473 7002 005	Tapping Screw 3×6(S)		12
	1-3		Switch PWB Unit	1	103	477 0263 018	3P Swelling Screw	Black	4
	1-4		Head phone PWB Unit	1	105	473 7005 002	Tapping Screw 3×10(S)		2
	2	204 8311 021	2P Pin Jack	1	106	473 7508 017	Tapping Screw 3×10(P)		1
	3	204 8262 002	1P Pin Jack	1					
	4	205 0618 110	25P D sub socket	1				With Screw	
	5	393 9511 201	LED Back Light	1					
	6	393 4139 002	LCD	1					
	7	211 0763 015	Slide Volume	1					
	8	212 4775 905	Tact Switch (Long ST)	12					
	9	393 9526 908	LED (RED)	1				SLR-305VC	
	10	393 9526 924	LED (GRN)	2				SLR-305MC	
	11	212 1039 000	1P Push Switch	1					
	12	417 0462 118	Radiator	1					
⊙	14	144 2371 118	Front Panel Ass'y	1					
⊙	15	146 1371 005	LED Window	3					
⊙	16	146 1496 029	Window	1					
⊙	17	411 0962 801	Chassis	1					
⊙	18	443 0518 003	PCB Holder	1					
	19	461 0706 114	Foot Sheet	2					
	20	461 0740 015	Sheet	2					
⊙	21	105 1130 106	Back Panel	1				U.S.A. and Canada Model	
⊙		105 1130 119	Back Panel	1				Europe Model	
⊙		105 1130 122	Back Panel	1				Multi-Voltage Model	
	22	337 0030 202	CD MECH. Unit (FG-71)	1					
⊙	23	441 1132 204	Bottom Plate	1					
⊙	25	GU-2752	Output PWB Unit Ass'y	1					
	26	211 0552 006	Adjust Resistor (V09QA102)	2					
	27	205 0428 009	3P Cannon Connector	2					
⊙	28	412 3875 008	Head Phone Bracket	1					
	29	112 0645 182	Head Phone Knob	1					
⚠	30	206 2110 004	AC Cord W/CONN.	1				U.S.A. and Canada Model	
⚠		206 2089 106	AC Cord W/CONN.	1				Europe and Multi-Voltage Model	
⚠		206 2128 009	AC Cord W/CONN.	1				U.K. Model	
⚠	31	445 0056 008	Cord Bush	1					
⚠	32	233 6122 003	Power Trans	1				U.S.A. and Canada Model	
⚠		233 6121 004	Power Trans	1				Europe and U.K. Model	
⚠		233 6120 005	Power Trans	1				Multi-Voltage Model	
	35	119 0081 006	Rubber Button(650)	1					
	36	119 0072 015	Rubber Button(C)	1					
	37	113 1357 265	Power SW. Button	1					
	38	113 1523 015	Slide Knob	1					
⊙	39	146 1394 134	Loader Panel	1					
	40	441 1627 117	P.Button Guide	1					
⊙	41	102 0425 224	Top Cover	1					
⚠	42	212 0359 008	Voltage Selector	1				Multi-Voltage Model only	
⊙	43	412 3629 102	VOL Selector Bracket	1				Multi-Voltage Model only	
	44	441 1633 004	P.W.B. Guide	1					
	45	461 0856 006	Rubber Spacer	1					
	46	449 0050 006	Card Spacer	1					

⊙ Part indicated with the mark "⊙" are not always in stock and possibly to take a long period of time for supplying, or in some case supplying of part may be refused.

PACKING & ACCESSORIES

**PARTS LIST OF
FG-71 MECHANISM UNIT**

Ref. No.	Part No.	Part Name	Remarks	Q'ty	Ref. No.	Part No.	Part Name	Remarks
	511 2647 000	INST.Manual		1	2	9KA 90H0 06	FS Fixing Screw	
	511 2648 009	INST.Manual	Europe Model Only	1	3	9KA 90H0 05	Feed Shaft	
	515 0692 004	DEL Warranty COM.	U.S.A. and Canada Model Only	1	7	9KA 80G0 17	Drive Gear (A)	
	203 2360 004	2P Pin Cord		1	8	9KA 80G0 18	Drive Gear (B)	
	504 0092 060	Styrene Paper	For AC Cord	1	9	499 0191 009	Laser P.U	KSS-240A
	505 0038 030	Poly Cover		1	12	9KS 01W1 47	Leaf Switch	
	202 0042 004	AC Adapter	Multi-Voltage Model Only	1	13	—	—	
	503 1130 009	Cushion		2	15	009 0051 001	12P FFC Cable	
	501 1739 132	Carton Case		1	16	443 1093 006	FFC Bush	
	505 0102 092	Styrene Paper			17	9KA 82G2 53	S5B-PH Connector Base	
					18	9KM 20S0 04	2x4 Screw	
					19	9KA 85G0 26	MECHA.Plate(FG70)	
					20	9KA 85G0 20	MECHA.Frame(FG70)	
					21	9KA 85G0 21	CD Tray(FG70)	
					22	9KA 85G0 04	Clamper Frame	
					23	9KA 85G0 22	UD Plate Gear(FG70)	
					24	9KA 85G0 06	Clamper (F)	
					25	9KA 85G0 07	Relay Gear(A)	
					26	9KA 85G0 08	Relay Gear(B)	
					27	9KA 85G0 09	Relay Gear(C)	
					28	9KA 85G0 10	Gear Belt(F)	
					29	9KA 85G0 30	Damper(FG40)	
					30	9KA 85P0 01	Clamper Plate (F)	
					31	9KA 85H0 01	Screw(F)	
					34	9KA 82G0 57	Magnet	
					35	9KA 91H0 02	3x8 (W-10) Screw	
					36	9KB 30B0 03	3x8 Baid Screw	
					37	9KM 26B0 04	2.6x4 Baid Screw	
					39	9KA 82G3 08	S5B-PH(RED)	
					40	9KA 85G0 27	CNW2(FG70)	
					41	9KS 01W1 48	OP/CL Switch(S5S12)	
					42	9KA 85S0 01	Spring (A)	
					43	9KA 85S0 02	Spring (B)	
					44	9KA 85S0 03	Spring (C)	
					45	9KA 85G0 33	Gear Guide	
					46	9KA 85G0 36	Tray Stopper	
					47	9KB 20B0 05	2x5 Baid (B)	
					48	9KS 11W6 04	STM / 2.1x6x0.4	
					50	9KA 85S0 05	Hold Spring	
					60	—	Spindle Motor Ass'y	
					61	—	—	
					62	9KA 85A0 06	Loading Motor Ass'y	
					62-1	9KA 85P0 05	Motor P.W.B.	
					63	9KA 85P0 18	Spacer 72	

EXPLODED VIEW OF FG-71 MECHANISM UNIT

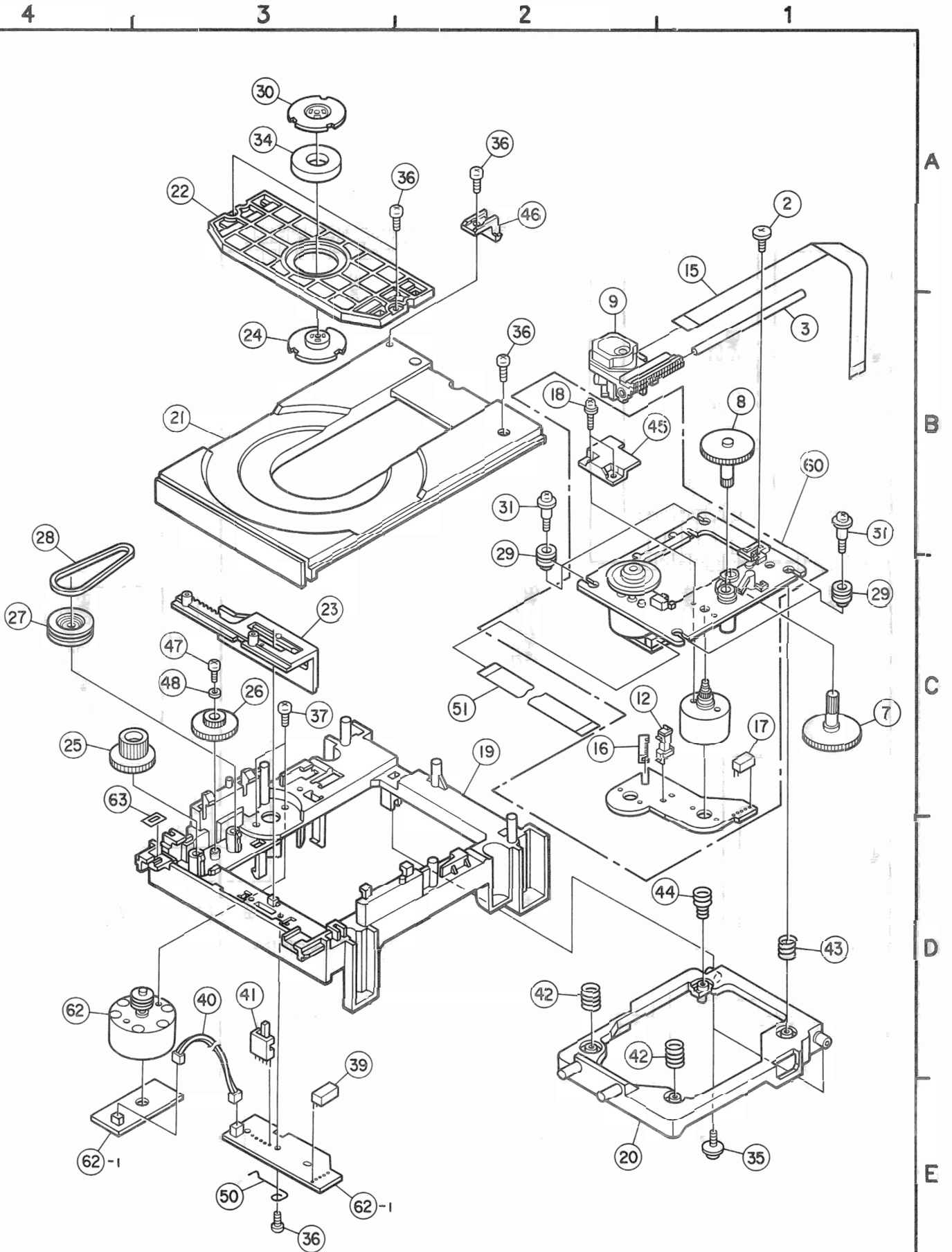

WIRING DIAGRAM

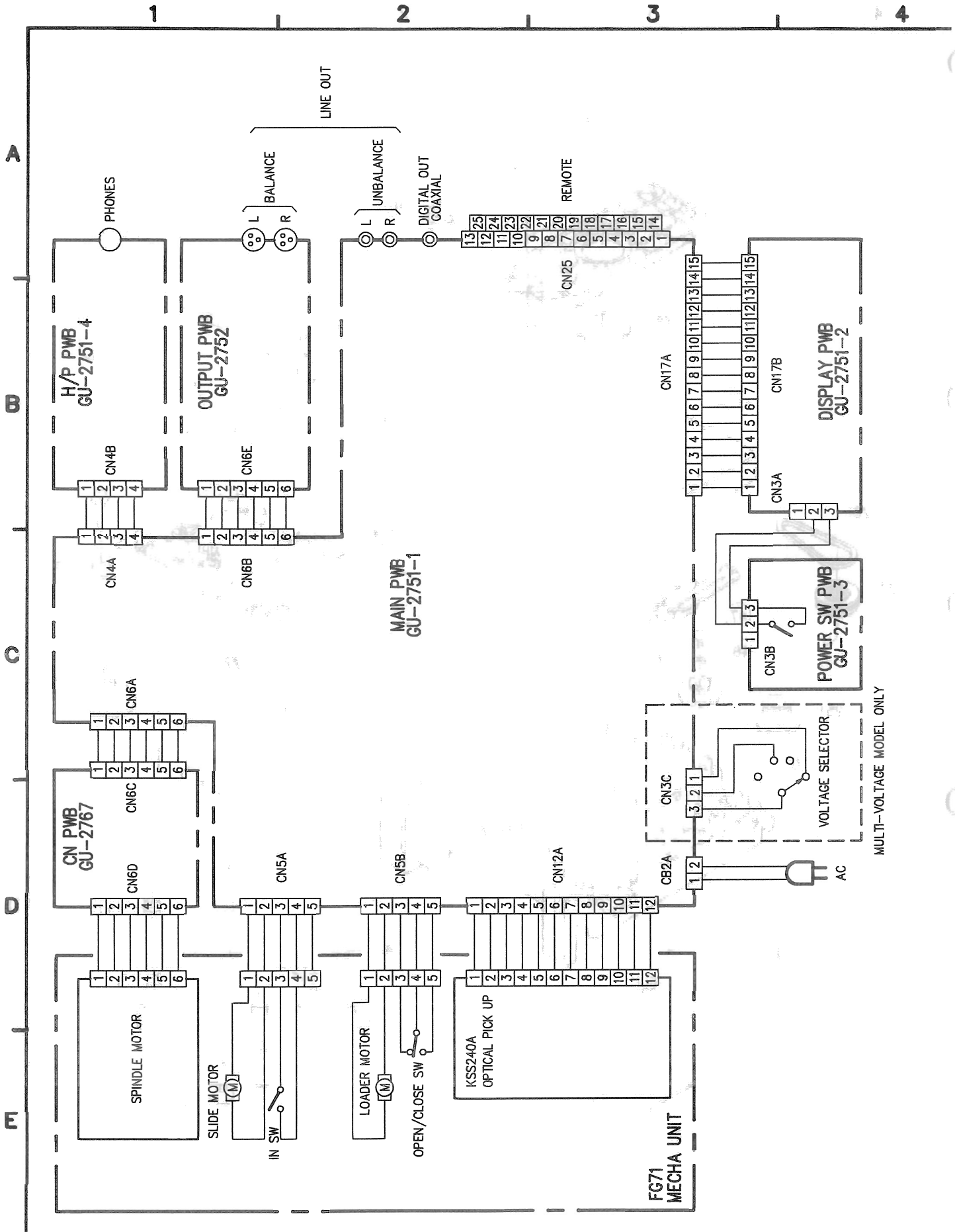

SEMICONDUCTORS

● IC's

μ PD78233GC-3B9(IC201)

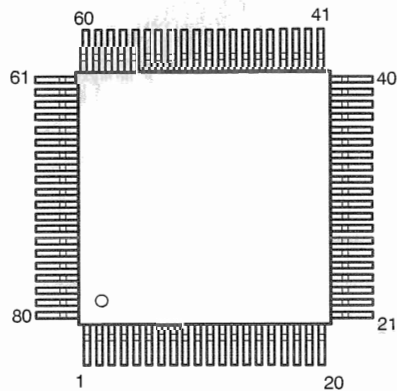

YSD221F (IC106)

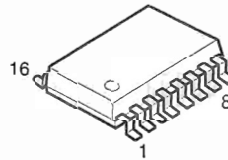

BA6392FP-T1(IC102)

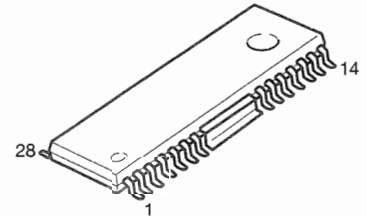

μ PD6381GF(IC301)

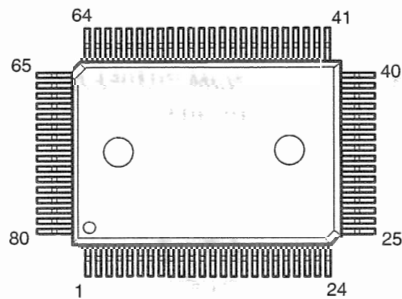

SN7438NS (IC207)
HD74HC00FP (IC208)
TC74HCU04FP (IC104)

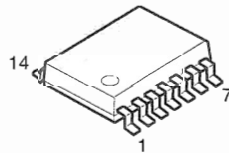

HD74HC00FP
SN7438NS

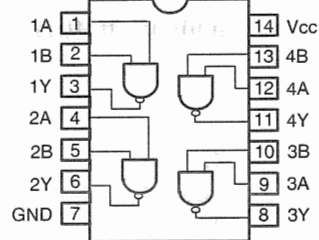

TC74HCU04FP

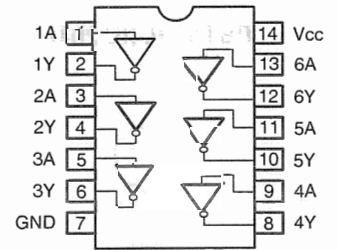

CXD2515Q(IC101)

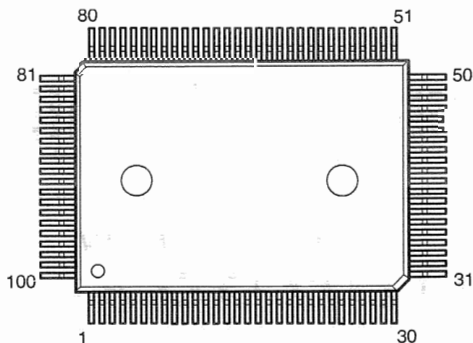

TC74HC573AF(IC202)
TC74HC574AF(IC205)
HD74HC245FP(IC206)

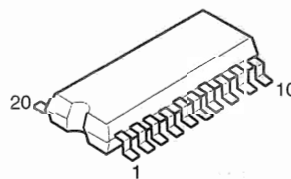

TMS27C256-15(IC203)
PCM-1700L(IC304)

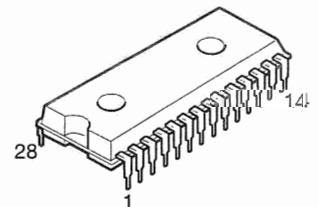

SM5841BS(IC303)

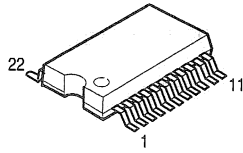

LC7582(IC501)

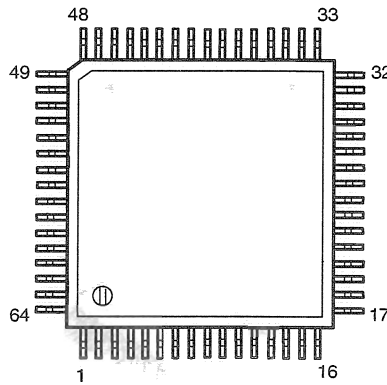

MSM514256B-70ZS (IC302)

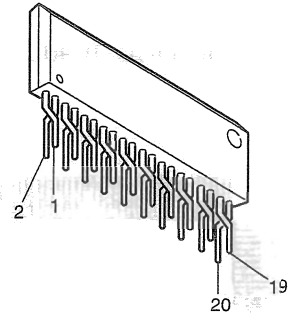

BA15218F(IC105,305)
X24C00 (IC209)

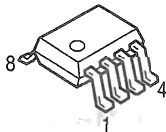

BA7042(IC103)
NE5532 (IC601,602)

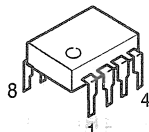

BA15218F
NE5532

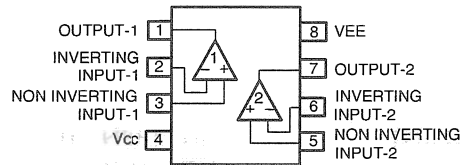

PST529C(IC204)

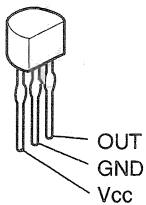

SI3050C (IC401)

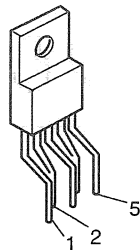

- 1.ADJUST
- 2.ON/OFF
- 3.GND
- 4.Vin
- 5.Vout

NJM78M05FA (IC402)

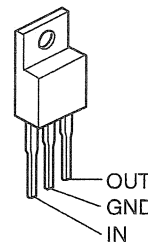

NJM79M05FA (IC403)

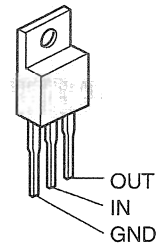

LCD(LC501)

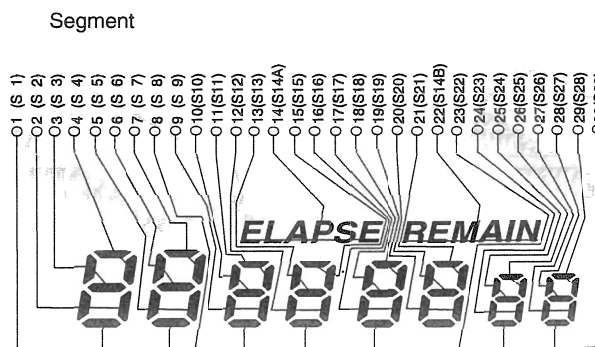

Common

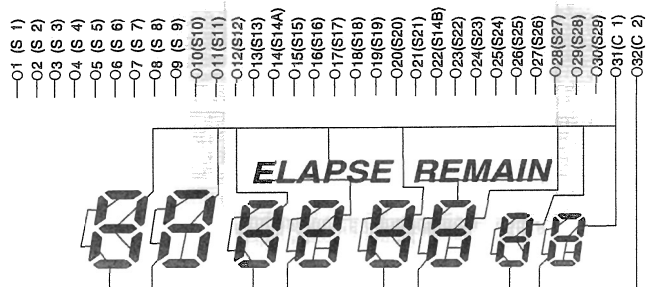

● TRANSISTORS

2SD2144STPU
(TR301~304)

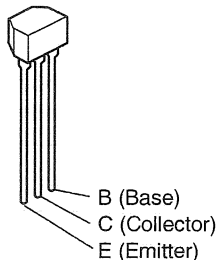

DTA114TS (TR305)
DTA143TS (TR201)
DTC114TS (TR306)

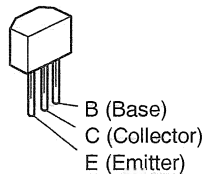

DTA TS Series

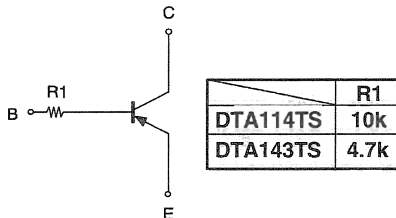

DTC 114 TS

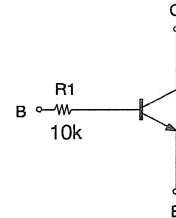

DTA114EK
(TR504)

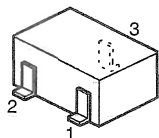

1: GND/Emitter
2: In/Base
3: Out/Collector

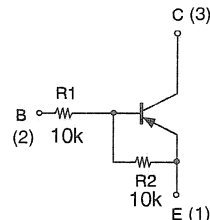

DTC114EK
(TR501~503)

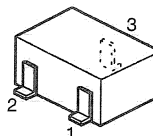

1: GND/Emitter
2: In/Base
3: Out/Collector

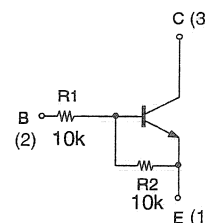

● DIODES

MA151A(D501~503)

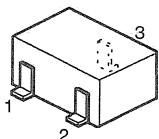

1: Cathode
2: NC
3: Anode

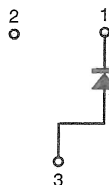

RBA402(D401)

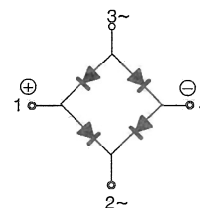
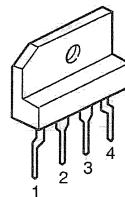

1SS270ATE
(D203~223,301)

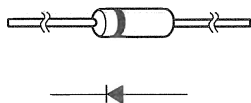

1SR35-200A (D403)

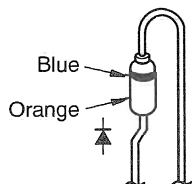

S1WB(A)10(D402)

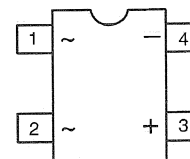
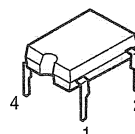

● LED

BACKLIGHT(LE501)

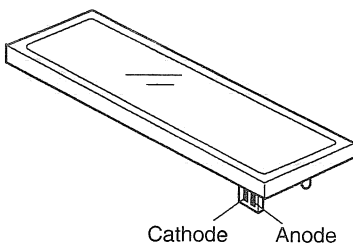

SLR-305VC(RED)(LE502)
SLR-305MC(GRN)(LE503,504)

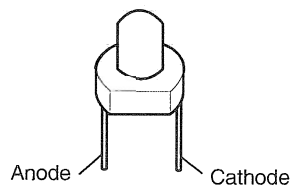

IC TERMINAL FUNCTION LIST

TABLE OF MICROCOMPUTER μ PD78233GC-3B9 (IC201) TERMINALS

Terminal No.	Symbol Name	I/O	Terminal Function
1	SCL	O	Serial communication enable signal for connected RC-35. Data read/write clock for X24C00 (IC209).
2	RST2	O	Reset signal of IC301 (μ PD6381GF).
3	LED0	O	LED/KEY scan matrix signal 1.
4	LED1	O	LED/KEY scan matrix signal 2.
5	LED2	O	LED/KEY scan matrix signal 3.
6	SDA	I/O	Communication reserved signal or busy signal for CD1. Read/write data of IC209.
7	RST-	I	Hard reset input. Reset at "L".
8	V _{DD}	—	+5V power supply.
9	X2	I	Clock oscillation circuit input 2.
10	X1	I	Clock oscillation circuit input 1.
11	V _{SS}	—	0V power supply.
12	CLCK	O	Clock for servo command, level command. Connected to IC101 (CXD2515), 303 (SM5841BS).
13	DATA	O	Data for servo command, level command. Connected to IC101 (CXD2515), 303 (SM5841BS).
14	XLAT	O	Latch pulse of servo command. Latched at falling edge.
15	SCLK	—	Clock for data reading from IC101 (CXD2515).
16	LDON	O	Laser ON/OFF signal of optical pickup. Laser emits light at "H".
17	LCLK	O	Command transmitting clock for LCD driver.
18	LDAT	O	Command data for LCD driver.
19	LCE	O	Chip enable signal for LCD driver.
20	SRST-	O	Reset signal of IC101 (CXD2515).
21	—	O	Not Used.
22	RE-	O	Enable signal output for external ROM. Mask item... fixed to "L", external ROM... pulse output for writing.
23	OE-	O	Enable signal output for external ROM. Mask item... fixed to "L", external ROM... pulse output for reading.
24	CS-	O	Chip select signal of IC301. Normally "H". "L" at select only.
25	C-/D	O	Command data designate signal of IC301. Command at "L", indicates data transmitting mode at "H".
26	SCK-	O	Clock for command transmission to IC301.
27	SI	O	Command data to IC301.
28	A15	O	Memory address 15. Not used. Mask item... fixed to "L".
29	A14	O	Memory address 14. Mask item... fixed to "L".
30	A13	O	Memory address 13. Mask item... fixed to "L".
31	A12	O	Memory address 12. Mask item... fixed to "L".
32	A11	O	Memory address 11. Mask item... fixed to "L".
33	A10	O	Memory address 10. Mask item... fixed to "L".
34	A9	O	Memory address 9. Mask item... fixed to "L".
35	A8	O	Memory address 8. Mask item... fixed to "L".
36	AD7	I/O	Data bus 7. Mask item... fixed to "L".
37	AD6	I/O	Data bus 6. Mask item... fixed to "L".
38	AD5	I/O	Data bus 5. Mask item... fixed to "L".
39	AD4	I/O	Data bus 4. Mask item... fixed to "L".
40	AD3	I/O	Data bus 3. Mask item... fixed to "L".
41	AD2	I/O	Data bus 2. Mask item... fixed to "L".
42	AD1	I/O	Data bus 1. Mask item... fixed to "L".
43	AD0	I/O	Data bus 0. Mask item... fixed to "L".
44	ASTB	O	Audio output mute signal. Mask item... fixed to "L".
45	V _{SS}	—	0V power supply.
46	MODE	I	Memory mode selection terminal. Use external ROM at "H", use mask ROM at "L". Mask item... "L", external ROM "H".
47	AMUTE	O	Audio output mute signal. Mute at "H".
48	SOCK	O	Clock for sub-code reading.

Terminal No.	Symbol Name	I/O	Terminal Function
49	SENS	I	Indication signal of servo actuating condition. Emits from IC101.
50	CLOSE-	I	Tray CLOSE switch. CLOSE state at "L".
51	OPEN	I	Tray OPEN switch. OPEN state at "L".
52	SQSO	I	Sub-code data input. Emits from IC101.
53	DFLAT	O	Command latch pulse for digital filter. Output to IC303.
54	CLD	O	Serial communication enable signal for connected DN-1000F.
55	V _{DD}	—	+5V power supply.
56	CDNO	O	Mechanism number input. Mechanism 1 at "L". Mechanism 2 at "H".
57	—	I	Not used. Fixed to "L".
58	—	I	Not used. Fixed to "L".
59	PITCH	I	Pitch volume input.
60	PMODE	I	Mode input for player.
61	SO	I	Serial communication input to IC301. (Normally "H")
62	—	I	Not used. Fixed to "L".
63	FOK	I	Input terminal.
64	AV _{DD}	—	+5V power supply for A/D converter.
65	AVREF1	—	+5V. A/D converter reference voltage.
66	AV _{SS}	—	0V power supply for A/D converter.
67	LOADER	O	Tray drive signal. Stops at 2.5V. CLOSE action at 3V. OPEN action at 2V.
68	—	O	Not used.
69	AVREF2	—	+5V. D/A converter reference voltage.
70	AVREF3	—	0V. D/A converter reference voltage.
71	KIN0	I	Key data 0.
72	KIN1	I	Key data 1.
73	KIN2	I	Key data 2.
74	KIN3	I	Key data 3.
75	KIN4	I	Key data 4.
76	RST	I	Input for +5V voltage observation. Shifts to "H" when POWER switch is turned off.
77	SCOR	I	Sub code sink input. Connect to IC101. Input 75 pulses per 1 second.
78	REMOT	I	Infrared-ray remote control signal input.
79	RXD-	I	Serial interface reception data.
80	TXD-	O	Serial interface transmission data.

TABLE OF DIGITAL SIGNAL PROCESSOR μ PD6381GF (IC301) TERMINALS

Terminal No.	Symbol Name	I/O	Terminal Function
1	DRDY	O	Command reception READY signal from microcomputer. Normally "H".
2	FSMASK	I	LRCK mask signal. Fixed to "L".
3	SEL	I	Clock input select. Fixed to "H".
4	—	I	Not used.
5	XO	O	X'tal oscillation output.
6	XI	I	X'tal oscillation input.
7	GND	—	0V power supply.
8	XFSO	O	Clock Output. Not used.
9	—	—	Not connected.
10	LRCKO	O	LR clock output. 44.1kHz.
11	WCLKO	O	Word clock output. 88.2kHz. Not used.
12	BCLKO	O	Bit clock output. 2.1MHz.
13	BRACK-	O	Break acknowledge output. Fixed to "H".
14	GND	—	0V power supply.
15	BRRQ-	I	Break request input. Fixed to "H".
16	FSRST-	I	Program counter reset input. Fixed to "H".
17	RST2-	I	Soft reset input. Normally "H".
18	RST-	I	Hard reset input. Normally "H".
19	A0	O	External RAM address 0.
20	A1	O	External RAM address 1.
21	A2	O	External RAM address 2.
22	A3	O	External RAM address 3.
23	A4	O	External RAM address 4.
24	A5	O	External RAM address 5.
25	A6	O	External RAM address 6.
26	A7	O	External RAM address 7.
27	A8	O	External RAM address 8.
28	A9	O	External RAM address 9. Not used.
29	A10	O	External RAM address 10. Not used.
30	A11	O	External RAM address 11. Not used.
31	A12	O	External RAM address 12. Not used.
32	A13	O	External RAM address 13. Not used.
33	V _{DD}	—	+5V power supply.
34	A14	O	External RAM address 14. Not used.
35	A15	O	External RAM address 15. Not used.
36	A16	O	External RAM address 16. Not used.
37	RAS-	O	External RAM low address strobe signal.
38	CAS-	O	External RAM column address strobe signal.
39	WE-	O	External RAM write enable signal.
40	I01	I/O	External RAM data 1.
41	I02	I/O	External RAM data 2.
42	I03	I/O	External RAM data 3.
43	I04	I/O	External RAM data 4.
44	I05	I/O	External RAM data 5. Not used.
45	I06	I/O	External RAM data 6. Not used.
46	I07	I/O	External RAM data 7. Not used.
47	I08	I/O	External RAM data 8. Not used.
48	I09	I/O	External RAM data 9. Not used.

Terminal No.	Symbol Name	I/O	Terminal Function
49	I010	I/O	External RAM data 10. Not used.
50	I011	I/O	External RAM data 11. Not used.
51	I012	I/O	External RAM data 12. Not used.
52	I013	I/O	External RAM data 13. Not used.
53	I014	I/O	External RAM data 14. Not used.
54	I015	I/O	External RAM data 15. Not used.
55	I016	I/O	External RAM data 16. Not used.
56	GND	—	0V power supply.
57	MD0	I	Mode select 0. Fixed to "L".
58	MD1	I	Mode select 1. Fixed to "H".
59	MD2	I	Mode select 2. Fixed to "L".
60	BCLK1	I	Bit clock input. 2.18MHz.
61	LRCK1	I	LR clock input. 44.1kHz.
62	BCLK2	I	Fixed to "L". Not used.
63	LRCK2	I	Fixed to "L". NOT used.
64	DI1	I	Data input.
65	DO1	O	Data output.
66	DI2	I	Fixed to "L". Not used.
67	DO2	O	Not used.
68	DO3	O	Not used.
69	DORQ-	I	Not used. Fixed to "H".
70	GF-	O	G flag output. Normally "H".
71	OVF-	O	Over flag output. Normally "H".
72	V _{DD}	—	+5V power supply.
73	TEST0	I	Fixed to "H".
74	TEST1	I	Fixed to "H".
75	SETRDY	O	Not used.
76	SO	O	Serial data output.
77	SCK-	I	Serial data input/output clock.
78	SI	I	Serial data input.
79	C-/D	I	Command /data designation signal. "L" - command, "H" - data.
80	CS-	I	Chip select input.

CXD2515Q (IC101) TERMINAL FUNCTION

Terminal No.	Symbol Name	I/O	Terminal Function
1	SRON	O	Sled drive output.
2	SRDR	O	Sled drive output.
3	SFON	O	Sled drive output.
4	TFDR	O	Tracking drive output.
5	TRON	O	Tracking drive output.
6	TRDR	O	Tracking drive output.
7	TFON	O	Tracking drive output.
8	FFDR	O	Focus drive output.
9	FRON	O	Focus drive output.
10	FRDR	O	Focus drive output.
11	FFON	O	Focus drive output.
12	VCOO	O	Oscillation circuit output for analog EFM PLL.
13	VCOI	I	Oscillation circuit input for analog EFM PLL. f _{LOCK} =8.6436MHz.
14	TEST	I	Test terminal, normally GND.
15	V _{SS}	—	Digital GND.
16	TES2	I	Test terminal, normally GND.
17	TES3	I	Test terminal, normally GND.
18	PDO	O	Charge pump output for analog EFM PLL.
19	VPCO	O	PLL charge pump output for variable pitch.
20	VCKI	I	Clock input from external VCO for variable pitch. f _{CENTER} =16.9344MHz.
21	AV _{DD}	—	Analog power supply.
22	IGEN	I	Current source reference resistor connecting terminal for OP amplifier.
23	AV _{SS}	—	Analog GND.
24	ADII	I	A/D converter input terminal.
25	ADIO	O	OP amplifier output terminal.
26	RFDC	I	RF signal input. Input range 2.15–5.0V (at V _{DD} =AV _{DD} =5.0V).
27	TE	I	Tracking error signal input. Input range 2.5V±1.0V (at V _{DD} =AV _{DD} =5.0V).
28	SE	I	Sled error signal input. Input range 2.5V±1.0V (at V _{DD} =AV _{DD} =5.0V).
29	FE	I	Focus error signal input. Input range 2.5V±1.0V (at V _{DD} =AV _{DD} =5.0V).
30	VC	I	Mid-point voltage input terminal.
31	FILO	O	Filter output for master PLL.
32	FILI	I	Filter input for master PLL.
33	PCO	O	Charge pump output for master PLL.
34	CLTV	I	VCO control voltage input for master.
35	AV _{SS}	—	Analog GND.
36	RFAC	I	EFM signal input.
37	BIAS	I	Asymmetry circuit constant current input.
38	ASYI	I	Asymmetry compare voltage input.
39	ASYO	O	EFM full swing output. (L=V _{SS} , H=V _{DD}).
40	AV _{DD}	—	Analog power supply.
41	V _{DD}	—	Digital power supply.
42	ASYE	I	Asymmetry circuit ON/OFF (L=OFF, H=ON).
43	PSSL	I	Audio data output mode shifting input. L to serial output, H to parallel output.
44	WDCK	O	48-bit slot D/A interface. Word clock f=2Fs.
45	LRCK	O	48-bit slot D/A interface. LR clock f=Fs.
46	DA16	O	DA16 output at PSSL=1. Serial data of 48-bit slot at PSSL=0.
47	DA15	O	DA15 output at PSSL=1. Bit clock of 48-bit slot at PSSL=0.
48	DA14	O	DA14 output at PSSL=1. Serial data of 64-bit slot at PSSL=0.

Terminal No.	Symbol Name	I/O	Terminal Function
49	DA13	O	DA13 output at PSSL=1. Bit clock of 64-bit slot at PSSL=0.
50	DA12	O	DA12 output at PSSL=1. LR clock of 64-bit slot at PSSL=0.
51	DA11	O	DA11 output at PSSL=1. GTOP output at PSSL=0.
52	DA10	O	DA10 output at PSSL=1. XUGF output at PSSL=0.
53	DA09	O	DA09 output at PSSL=1. XPLCK output at PSSL=0.
54	DA08	O	DA08 output at PSSL=1. GFS output at PSSL=0.
55	DA07	O	DA07 output at PSSL=1. RFCK output at PSSL=0.
56	DA06	O	DA06 output at PSSL=1. C2PO output at PSSL=0.
57	DA05	O	DA05 output at PSSL=1. XRAOF output at PSSL=0.
58	DA04	O	DA04 output at PSSL=1. MNT3 output at PSSL=0.
59	DA03	O	DA03 output at PSSL=1. MNT2 output at PSSL=0.
60	DA02	O	DA02 output at PSSL=1. MNT1 output at PSSL=0.
61	DA01	O	DA01 output at PSSL=1. MNT0 output at PSSL=0.
62	XTAI	I	X'tal oscillation circuit input. 16.9344MHz or 33.8688MHz input.
63	XTAO	O	X'tal oscillation circuit output.
64	XTSL	I	X'tal selection input terminal. L at X'tal for 16.9344MHz, at 33.8688MHz turns to H.
65	Vss	—	Digital GND.
66	FSTI	I	2/3 divided input of terminals 62 and 63.
67	FSTO	O	2/3 divided input of terminals 62 and 63. Unvarying by variable pitch.
68	C4M	O	4.2366MHz output. Simultaneously varies when variable pitched.
69	C16M	O	16.9344MHz output. Simultaneously varies when variable pitched.
70	MD2	I	Digital-out ON/OFF control terminal (L=OFF, H=ON).
71	DOUT	O	Digital-out output terminal.
72	EMPH	O	Emphasis mode output of playback disc (L at without emphasis, H at emphasized).
73	WFCK	O	WFCK output.
74	SCOR	O	Subcode sync output terminal (H at detecting either one of SO or SI subcode sync).
75	SBSO	O	Serial output of sub P-W.
76	EXCK	I	Clock input for SBSO read out.
77	SQSO	O	Subcode 10-bit output. PCM peak data, level data 16-bit output.
78	SQCK	I	Clock input for SQSO read out.
79	MUTE	I	Mute shifting terminal (H to mute).
80	SENS	O	SENS output. Outputs to CPU.
81	XRST	I	System reset (L to reset).
82	DIRC	I	Used for at I-track jump.
83	SCLK	I	Clock for SENS serial data reading.
84	DFSW	I	DFCT shifting terminal (H to DFCT countermeasure circuit OFF).
85	ATSK	I	Anti-shock terminal.
86	DATA	I	Serial data input from CPU.
87	XLAT	I	Latch input from CPU.
88	CLOCK	I	Serial data transfer clock input from CPU.
89	COUT	O	Number of track count signal output.
90	VDD	—	Digital power supply.
91	MI RR	O	Mirror signal output.
92	DFCT	O	Defect signal output.
93	FOK	O	Focus OK output.
94	FSW	O	Output filter shifting output of spindle motor.
95	MON	O	ON/OFF control output of spindle motor.
96	MDP	O	Servo control of spindle motor.
97	MDS	O	Servo control of spindle motor.
98	LOCK	O	Sampling GFS with 460Hz and outputs H at GFS is H. Outputs L when continuously 8 times L.
99	SSTP	I	Terminal for inner most circle detection signal of disc.
100	SFDR	O	Sled drive output.

- Note:
- 64-bit slot is 2's compliment output of LSB first, 48-bit slot is 2's compliment output of MSB first.
 - GTOP is to monitor the protection condition of Frame Sync. (H: Sync protect window open.)
 - XUGF is Frame Sync obtained from EFM signal and is negative pulse.
 - XPLCK is reversal of EFM PLL clock. PLL is so made the rising edge to meet shifting point of EFM signal.
 - GFS signal is a signal to turn to H when frame Sync and inserted protection timing coincide.
 - RFCK is obtained with the accuracy of X'tal. The signal of 136 μ s cycle.
 - C2PO is a signal to indicate the state of data error.
 - XRAOF is a generating signal when 32kRAM exceeds ± 28 frame jitter margin.

SCHEMATIC DIAGRAM

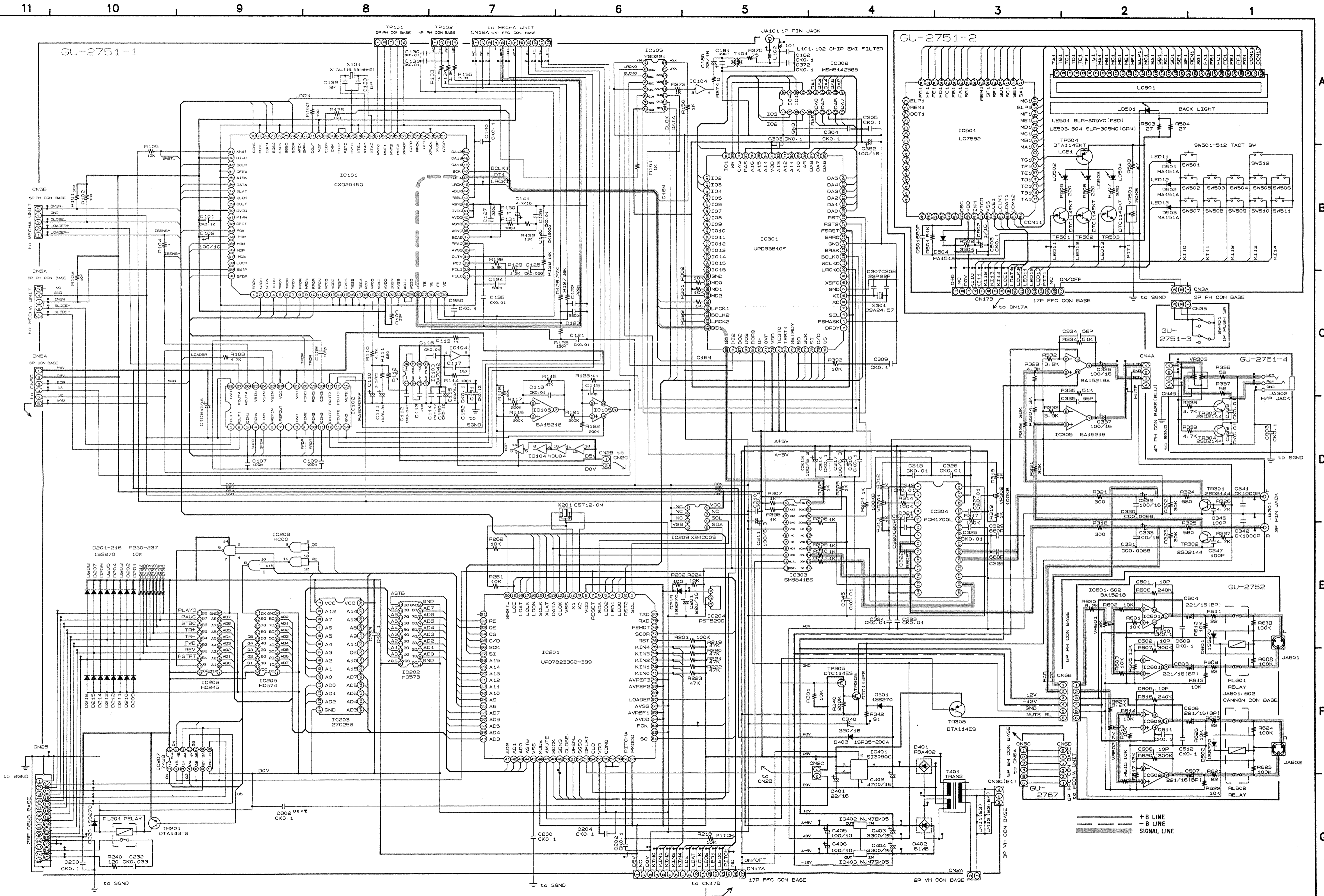

WARNING:
Parts marked with this symbol have critical characteristics. Use ONLY replacement parts recommended by the manufacturer.

CAUTION:
Before returning the unit to the customer, make sure you make either (1) a leakage current check or (2) a line to chassis resistance check. If the leakage current exceeds 0.5 milliamperes, or if the resistance from chassis to either side of the power cord is less than 240 kohms, the unit is defective.

WARNING:
DO NOT return the unit to the customer until the problem is located and corrected.

NOTES:
Circuit and parts are subject to change without prior notice.

NOTES
ALL RESISTANCE VALUES IN OHM. k=1,000 OHM, M=1,000,000 OHM
ALL CAPACITANCE VALUES IN MICRO FARAD, P=MICRO-MICRO FARAD
EACH VOLTAGE AND CURRENT ARE MEASURED AT NO SIGNAL INPUT CONDITION.
CIRCUIT AND PARTS ARE SUBJECT TO CHANGE WITHOUT PRIOR NOTICE.

DEMON

DENON

NIPPON COLUMBIA CO., LTD.

14-14, AKASAKA 4-CHOME, MINATO-KU, TOKYO 107-11, JAPAN

Telephone: 03 (3584) 8111

Cable: NIPPON COLUMBIA TOKYO Telex: JAPANOLA J22591