

HiFi ENGINE®

For more Hi-Fi manuals and set-up information
please visit www.hifiengine.com

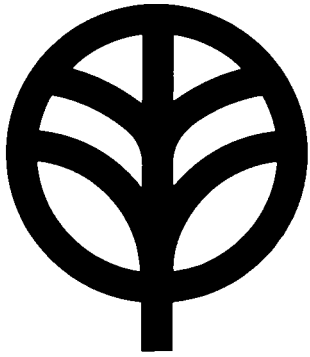

KENWOOD
HI/FI STEREO COMPONENTS

SERVICE MANUAL

L-07C

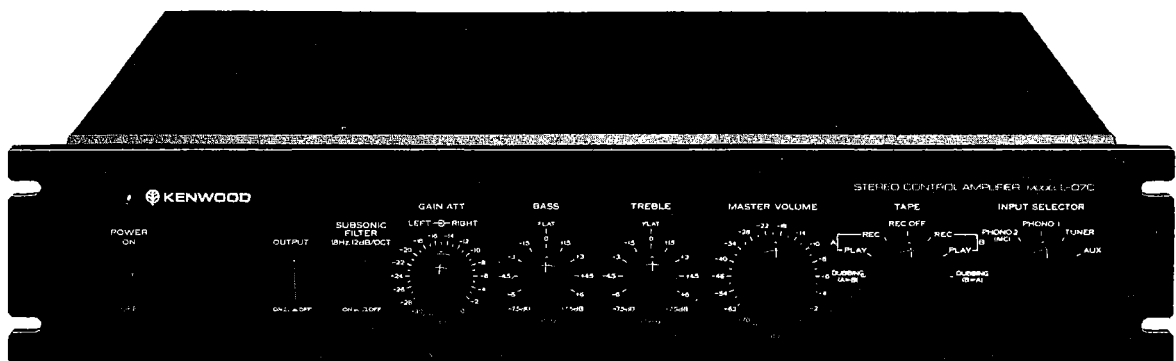

STEREO CONTROL AMPLIFIER

CONTENTS

EXTERNAL VIEW.....	3
INTERNAL VIEW.....	4
CIRCUIT DESCRIPTION.....	5
DESTINATIONS' PARTS LIST.....	14
PARTS LIST.....	15
ADJUSTMENT.....	17
PC BOARD (POWER SUPPLY).....	17
MODIFICATION SCHEMATIC.....	17
PC BOARD (AUDIO).....	18
SEMICONDUCTORS' SUBSTITUTIONS.....	18
MODIFICATION SCHEMATIC (POWER SUPPLY).....	18
SCHEMATIC DIAGRAM.....	19
SPECIFICATIONS.....	20

Note 1:

The products are subject to modification in components and circuits in different countries and regions. This is because each products must be used under the best condition.

This manual provides information of modification based on the standard to the U.S. for the convenience of ordering associated components and parts.

U.S.A.....	K
Canada.....	P
Europe.....	W
England.....	T
Scandinavia.....	L
Other Areas.....	M

Note 2:

Symbol ☆ in parts list means the new parts.

INTERNAL VIEW

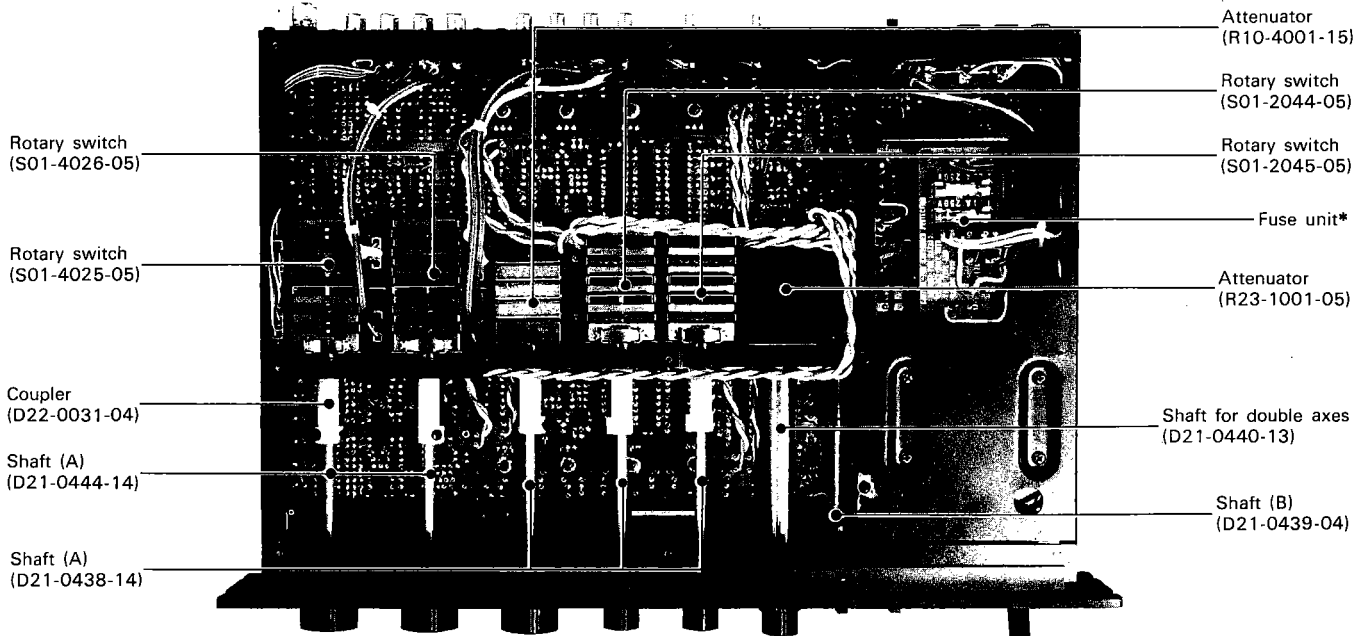
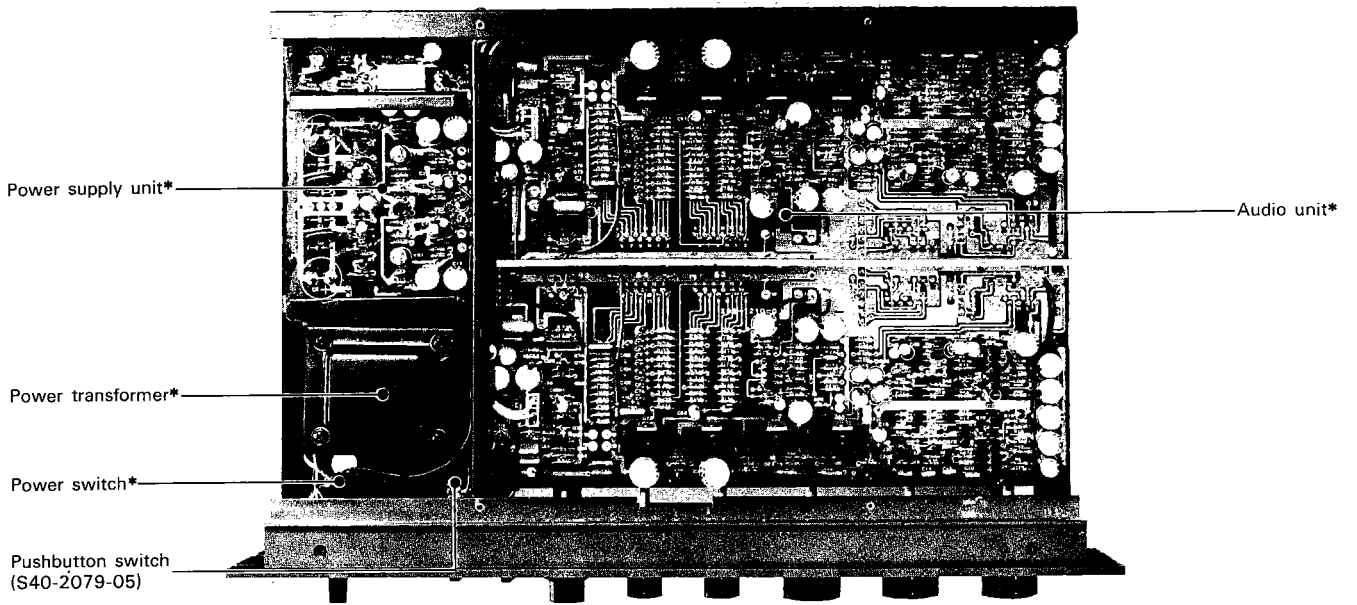

* Refer to Destinations' Parts List.

CIRCUIT DESCRIPTION

BLOCK DIAGRAM

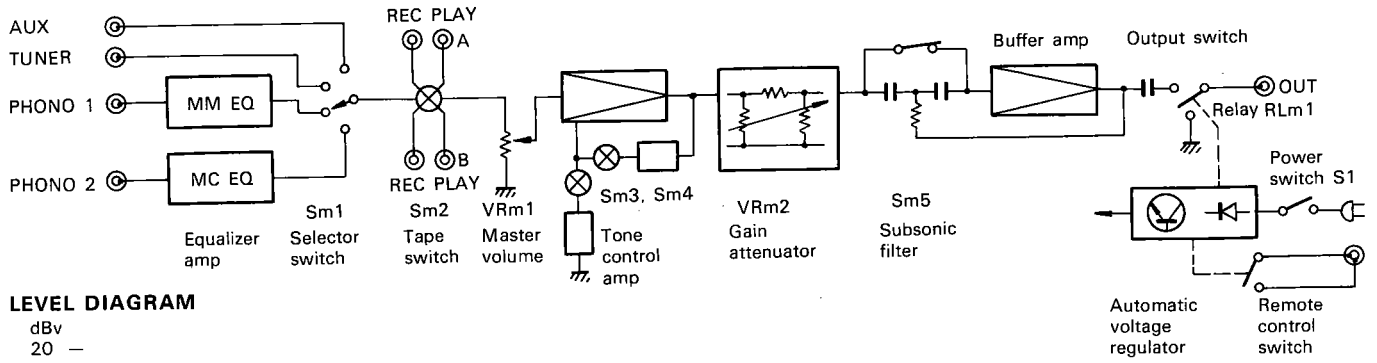

LEVEL DIAGRAM

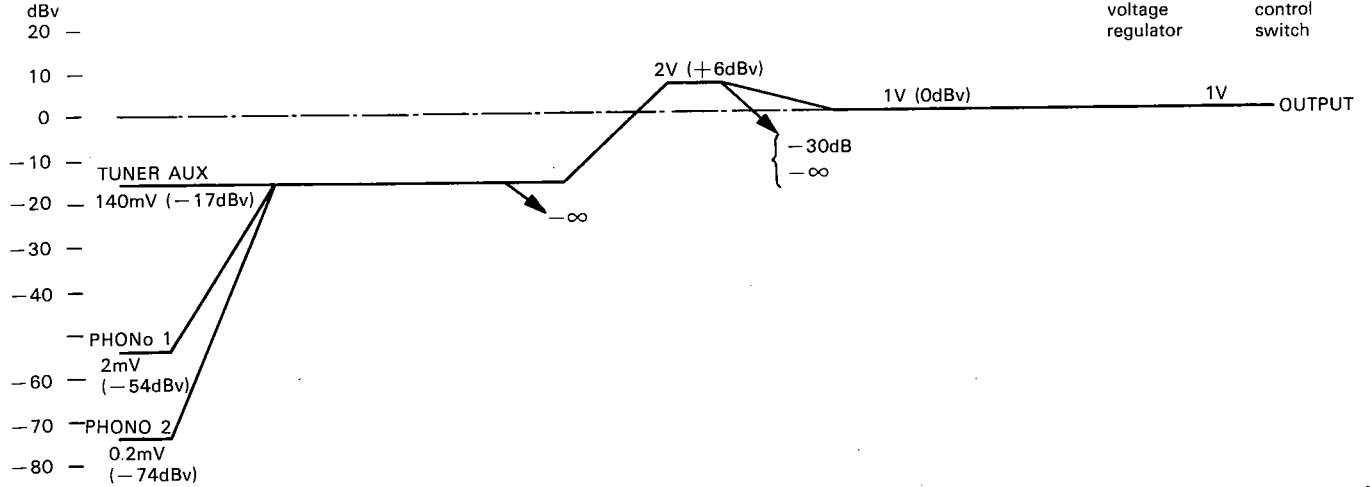

GENERAL DESCRIPTION

The model L-07C is a stereo control amplifier designed to be used with the model L-07M, a monoural DC power amplifier. They have designed aiming at high performance in physical characteristics and sound quality. And we are recommending highly the Direct Drive Amplifier System to bring out the best performance from the model L-07C and L-07M.

CONVENTIONAL CONNECTION SYSTEM

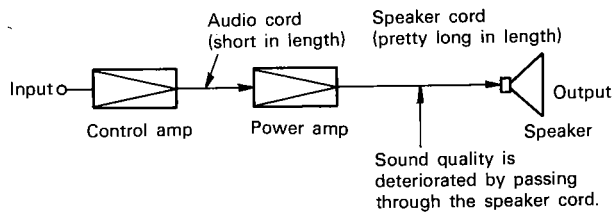

DIRECT DRIVE AMPLIFIER SYSTEM

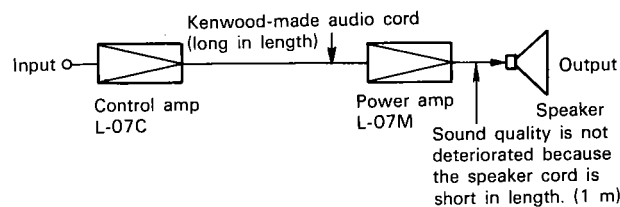

We have had a good command of the circuit design technique and the manufacturing in the model L-07C and L-07M to actualize the Direct Drive Amplifier System and to improve the performance of the units.

CIRCUIT CONNECTIONS

The model L-07C consists of two equalizer amplifiers, one with 2mV input sensitivity is for the MM-type cartridge and the other with 0.2mV input sensitivity is for the MC-type cartridge, a tone control amplifier and a buffer amplifier of 0 dB gain. (See BLOCK DIAGRAM.)

DIRECT DRIVE AMPLIFIER SYSTEM

The different points between the Direct Drive Amplifier System and the conventional connection system are the length of an audio cord and a speaker cord. It is impossible to use the conventional control amplifier and power amplifier in the Direct Drive Amplifier System as they are. We have used newly developed technique in the model L-07C and L-07M for that reason.

Table: Audio cord and Speaker cord

	Audio cord	Speaker cord
Role	Transmission of small signal voltage	Transmission of large signal voltage
Output impedance of previous stage	10Ω ~ 1kΩ	Almost 0Ω
Load condition	<ul style="list-style-type: none"> • 20kΩ ~ 100kΩ • Not influenced by signal frequency • Not influenced signal level • Slight input capacity • No reaction 	<ul style="list-style-type: none"> • Indication 4Ω ~ 16Ω • Influenced by signal frequency • Influenced by signal level • Includes reactance component • Influenced by back electro-motive force of speaker
Influence to performance	Little (only capacitor component)	Large (inductance, capacitance, resistance)
Influence to sound quality	Little	Large
Influence from cord length	Little	Large
Influence from external induction	Susceptible	Little

CIRCUIT DESCRIPTION

OUTPUT IMPEDANCE OF CONTROL AMPLIFIER

The Direct Drive Amplifier System needs the audio cord of 12 meters in length. The influence from an external induction to the amplifiers can be reduced by shielding the audio cord perfectly. Since the audio cord has a capacitor component of 200pF to 300pF per meter, the influence to the high cut frequency is an important matter. Suppose that we use the audio cord with a 250pF/m of 20 meters, the total capacitor component is about 5000pF.

The output impedance Z_o of a control amplifier must be below 10Ω to actualize the performance of 500 kHz gain -0.1 dB to 1 kHz gain 0 dB.

This means that the high cut frequency of a control amplifier is 3.2 MHz.

Note:

$$f \text{ (cut off frequency)} = \frac{1}{2\pi CZ_o}$$

where, C is 5000pF, f is 3.2 MHz
 $\therefore Z_o \approx 10\Omega$

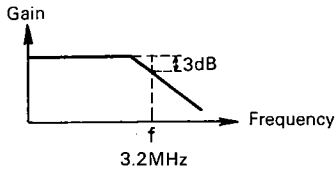
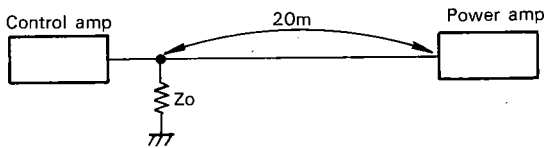

CONVENTIONAL CONTROL AMP.

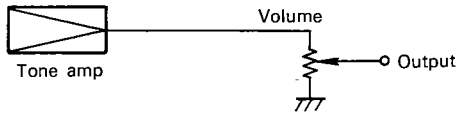

KENWOOD L-07C

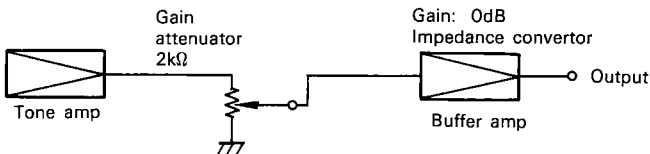

Since the conventional control amplifier uses a volume at an output circuit, it is difficult to lower the output impedance. The model L-07C uses a buffer amplifier of 100% negative feedback type as an impedance convertor, and it has become possible to actualize an ultra low output impedance.

EQUALIZER AMPLIFIER

The model L-07C has two equalizer amplifier for the MM-type cartridge and for the MC-type cartridge. When a head amplifier for the MC-type cartridge is used as a preamplifier for an equalizer amplifier, a selector switch is inserted in front of the equalizer amplifier as shown in the illustration.

Since an output level of the MM-type cartridge is a few mV, it will deteriorate the sound quality. For this reason, the model L-07C employs a private equalizer amplifier for the MC-type cartridge in place of a head amplifier. And, the pin jacks of PHONO 1 and PHONO 2 are plated with gold from this point of view.

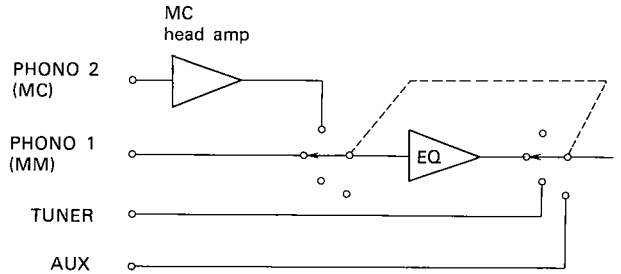

When MC head amp is used

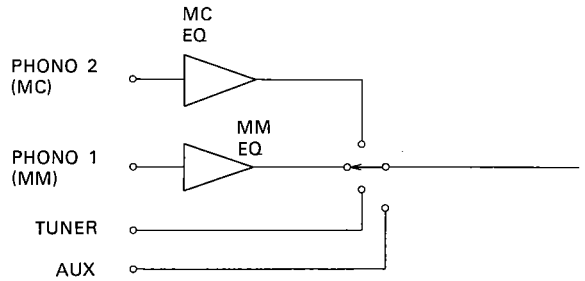

KENWOOD L-07C

CIRCUIT DESCRIPTION

EQUALIZER AMPLIFIER FOR MC-TYPE CARTRIDGE

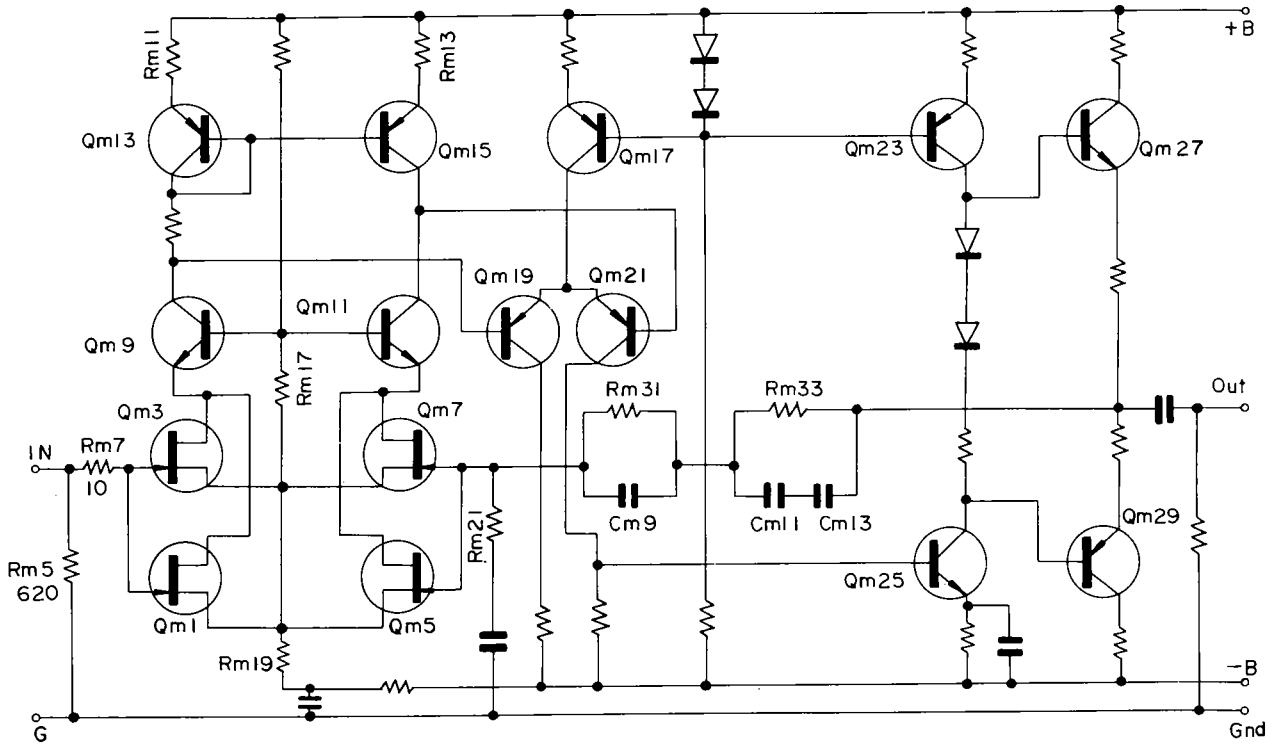

- Qm1, 3, 5, 7 : Parallel connected FET differential amplifier (first stage)
- Qm1, 3, 9 : Cascode circuit
- Qm5, 7, 11 : Constant current circuit for Qm19, 21
- Qm13, 15 : Class-A amplifier (third stage)
- Qm19, 21 : Single ended push-pull circuit (final stage)

- Qm17 : Constant current circuit for Qm19, 21
- Qm25 : Class-A amplifier (third stage)
- Qm23 : Constant current circuit for Qm25
- Qm27, 29 : Single ended push-pull circuit (final stage)

PARALLEL CONNECTED FET DIFFERENTIAL AMPLIFIER (Qm1, 3, 5, 7)

A first stage is an FET ICL (input capacitorless) differential amplifier generally used in the Kenwood integrated amplifiers from before. FETs are parallel connected to reduce the thermal noise of FET. This is a self-bias type circuit. The gate bias is provided by source resistor Rm19.

The input impedance of this circuit almost depends on Rm5. We have chosen 620Ω as an optimum load impedance value for the MC-type cartridge.

Since the gate potential is held at 0V as a result of using the self-bias type circuit, it makes possible to couple the cartridge to the input circuit directly.

Note:

FET's operation is almost the same as a triode's. A drain current ID is

$$I_D = I_{DSS} \left(1 - \frac{V_{GS}}{V_P}\right)^2$$

where, VGS is source-gate voltage

VP is pinch-off voltage (VGS at ID = 0)

IDSS is saturation drain current (ID at VGS = 0)

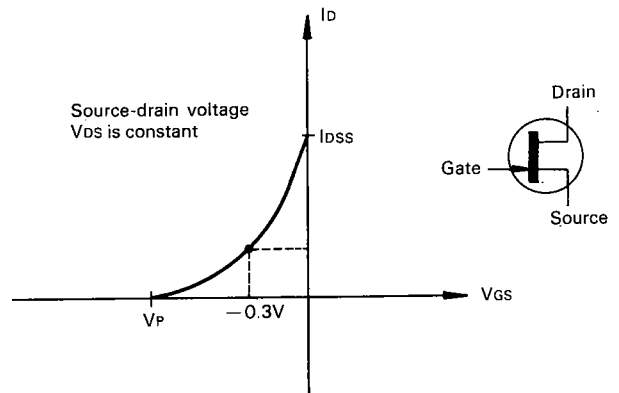

VGS - ID characteristic of 2SK68A(N)

This circuit employs 2SK68A of N rank (IDSS ranges between 4 mA and 12 mA) and sets VGS at -0.3V.

CIRCUIT DESCRIPTION

Note: About CMRR and Differential Amplifier

It is well known that a differential amplifier produces an output proportional to the difference of a level between two inputs, and it can reduce the influence of drifts by using equal transistors in characteristics.

Ideally, the output of the amplifier is 0 in case of both inputs are the same level in phase. But practically, it produces a little output at that time.

A well-designed amplifier produces less output in case of it. The ratio of Differential Mode Gain; DMG to Common mode gain; CMG is defined as Common Mode Rejection Ratio; CMRR.

$$CMRR = \frac{DMG}{CMG}$$

A good differential amplifier's CMG is low so that its CMRR is high.

Here we use the Current Mirror Circuit which is the one of the constant current circuits to improve CMRR.

PARALLEL CONNECTION OF FETs

It is a difficult point to improve the signal to noise ratio of a equalizer amplifier for the MC-type cartridge. Noises occurring by use of FET is as follows.

- a. Thermal noise caused by channel resistance. (1/gm, where gm is transconductance)
- b. Shot noise caused by drain-gate leakage current.
- c. 1/f noise increasing inversely proportional to frequency.

1. Countermeasure for thermal noise.

$$\begin{aligned} \text{Thermal noise} &= \sqrt{4KTBR} \\ &= \sqrt{4KT B \frac{1}{g_m}} \end{aligned}$$

where, $\left\{ \begin{array}{l} K \text{ is Boltzmann constant} \\ T \text{ is absolute temperature} \\ B \text{ is noise band width} \\ R \text{ is resistance component} \end{array} \right.$

From this equation we see that the thermal noise can be reduced by increasing gm. Gm is almost doubled in its value by connecting FETs in parallel. And the thermal noise will become $\sqrt{1/2}$.

2. Countermeasure for shot noise

The drain-gate leakage current increases proportional to the drain-source voltage, V_{DS}. A cascode circuit can make V_{DS} lowered inspite of the high power supply voltage provided to realize the high dynamic range of the circuit in characteristics. The shot noise will be reduced as a result.

3. Countermeasure for 1/f noise

1/f noise can be reduced by using a low noise FET named 2SK68A.

CASCODE CIRCUIT

(Qm1, 3) and Qm9 form a cascode amplifier.

An advantage of cascode connection becomes apparent at high frequencies, where the capacitance between gate and drain reduces the gain of the amplifier. Use of the cascode connection significantly reduces the effect of this capacitance and results in a wider-band high-gain amplifier. It was used in a triode circuit as a preamplifier of an ultra short wave receiver for this reason.

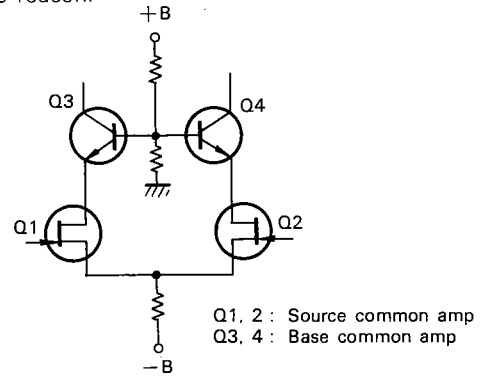

Normally used cascode amplifier

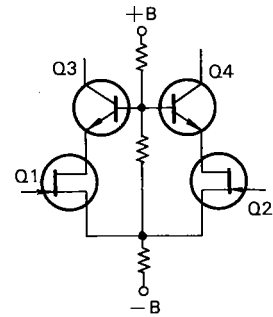

Cascode amplifier used in the L-07C

Here, the cascode amplifier is used to provide DC LEVEL SHIFTING. The L-07C uses high power supply voltage, that is $\pm 47V$, to actualize a high dynamic range of the circuit in characteristics.

In the case of not using the cascode amplifier, V_{DS} is high so that much gate-drain leakage current flows resulting in the shot noise increase.

In this circuit V_{DS} of Qm1 (Qm3) is set at a low voltage, 8V by use of the cascode connection. Besides the base of Qm9 is connected with the source of Qm1 (Qm3) via Rm17 so that V_{DS} will not be varied by the signal.

If V_{DS} does not remains at a constant value, the feedback capacitance Cr_{SS} varies as V_{DS} does and it will deteriorate the harmonic distortion.

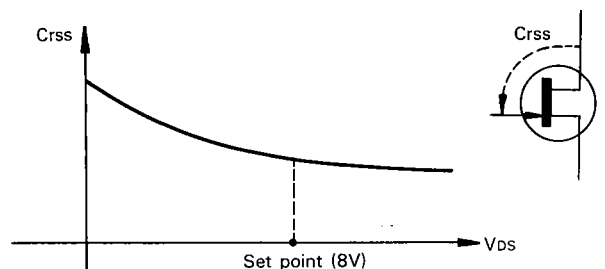

In the normally used cascode amplifier.

Cr_{SS} changes as V_{DS} does. It causes the deterioration of the harmonic distortion.

CIRCUIT DESCRIPTION

CURRENT MIRROR CIRCUIT

Qm13 and Qm15 form a current mirror circuit. The first stage of this equalizer amplifier is designed to provide the high-gain with a low noise, improving the signal to noise ratio.

A current mirror circuit is one of the constant current circuits. It increases the first stage's gain, here.

The operating currents of Qm1, 3 and Qm5, 7 are controlled by the gate-source voltage V_{GS} of Qm1, 3. Qm1 and Qm3 are supplied with a set drain current through Qm13. The drain current of Qm5, 7 is controlled by a constant current circuit Qm15. Since the bias of the constant current circuit is supplied from the collector potential of Qm13, the operating current of Qm5, 7 is controlled by the one of Qm1, 3 which flows through Qm13. Since R_{m11} and R_{m13} , the emitter resistor of Qm13 or Qm15, are the same value and Qm13 is equal to Qm15 in characteristics, the operating current of Qm1, 3 is equal to the one of Qm5, 7.

That is: the current drift of Qm1, 3 causes a change to the current of Qm5, 7 as if holding it to a mirror. In this way, the operating currents of Qm1, 3 and Qm5, 7 are set in the equally balanced condition, resulting in the excellent stability of the circuit.

FROM SECOND STAGE ON

The second stage consists of the differential amplifier Qm19, 21. The constant current circuit Qm17 is added to improve CMRR of the differential amplifier. The third stage consists of the class A amplifier Qm25. The constant current circuit Qm23 is added to increase the gain.

The final stage consists of a single ended push-pull circuit, SEPP. Its bias current is set at 7 mA. To improve the signal to noise ratio, the input resistor R_{m7} and the feedback resistor R_{m21} are designed the small values. Because the thermal noise of resistors increases proportional to the signal source resistor's value. And SEPP, which has a low output impedance, is employed for using the feedback resistor of a low value.

Note: Constant Current Circuit

The figure shows a constant current circuit Q2 used as a load of Q1. Since the base potential of Q2 is kept constant by the diodes, the base-emitter voltage V_{BE} remains at a constant value keeping I_C constant. That is: I_C of Q1 does not change even if its V_{CE} changes. Now, we are apt to think that the circuit cannot amplify the signal under the constant I_C because a transistor amplification should be done by varying I_C according to the change of I_B .

In this case, we understand it as follows.

The internal resistance of Q2 varies in proportion to the change of Q1's I_C . If Q1's I_C intends to increase, the internal resistance of Q2 will increase and if the former intends to decrease, the latter will decrease. For this reason Q1's I_C is kept constant at all times. On the other hand, the voltage of the output point varies in proportion to the signal level because the internal resistance of Q2 varies under the constant I_C . In this way the signal is amplified.

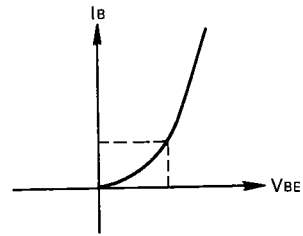
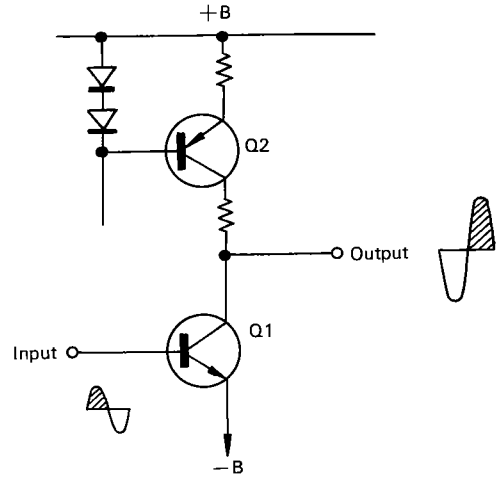

I_B is determined by V_{BE} .

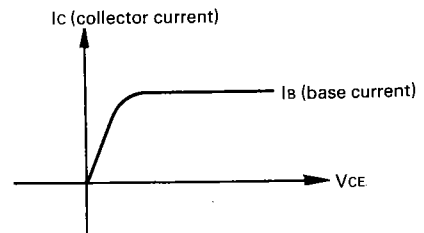

I_C is kept constant under the constant I_B .

CIRCUIT DESCRIPTION

EQUALIZER AMPLIFIER FOR MM-TYPE CARTRIDGE

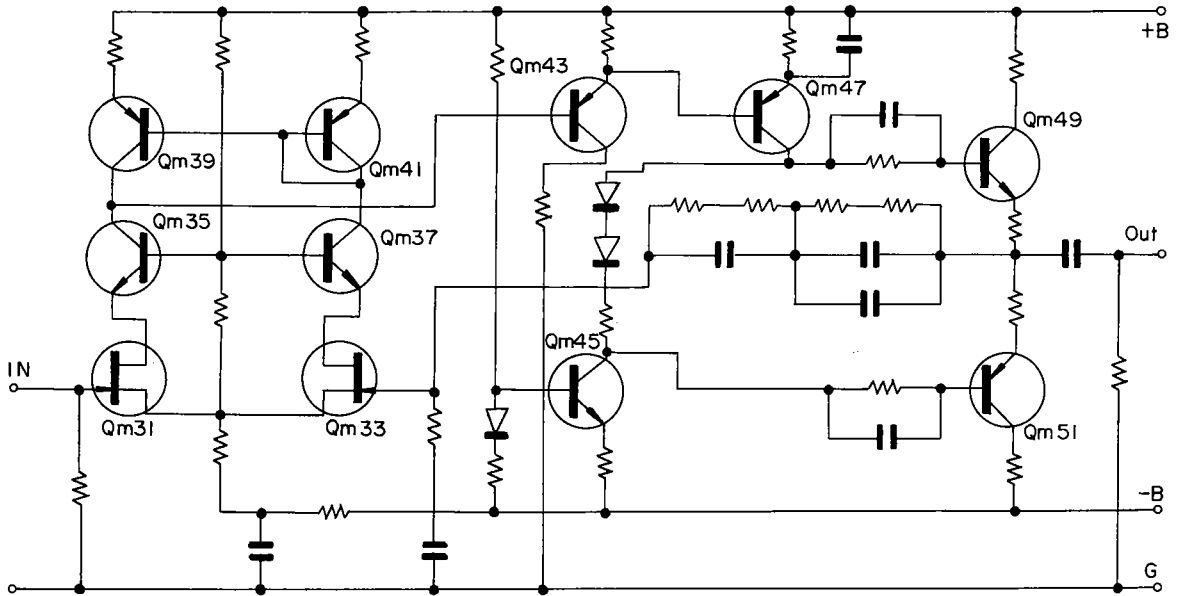

The equalizer amplifier for the MM-type cartridge is same as the one for the MC-type cartridge basically. The different points are that the former does not use FETs in parallel and uses a emitter follower circuit in place of the differential amplifier in the second stage. The equivalent circuit of the MM-type cartridge is indicated as follows:

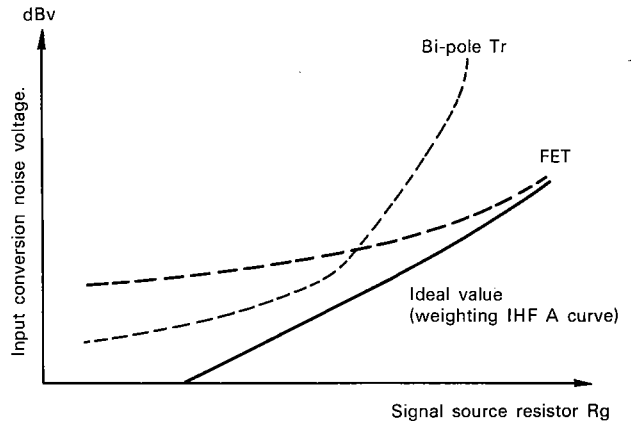
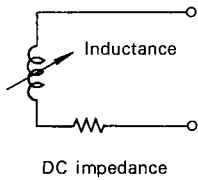

Generally, the AC impedance of the MM-type cartridge is about $5k\Omega$ at a 1 kHz sine wave supplied and it increases according as the frequency of the sine wave goes high. The noise of a bi-pole transistor increases suddenly when the value of the signal source resistor consisting of a cartridge impedance and a input resistor is over a certain point. On the other hand, the noise of FET is not much influenced by the value of the signal source resistor. Therefore using FET is better than using a bi-pole transistor in the input circuit of the equalizer amplifier for the MM-type cartridge.

CIRCUIT DESCRIPTION

TONE AMPLIFIER

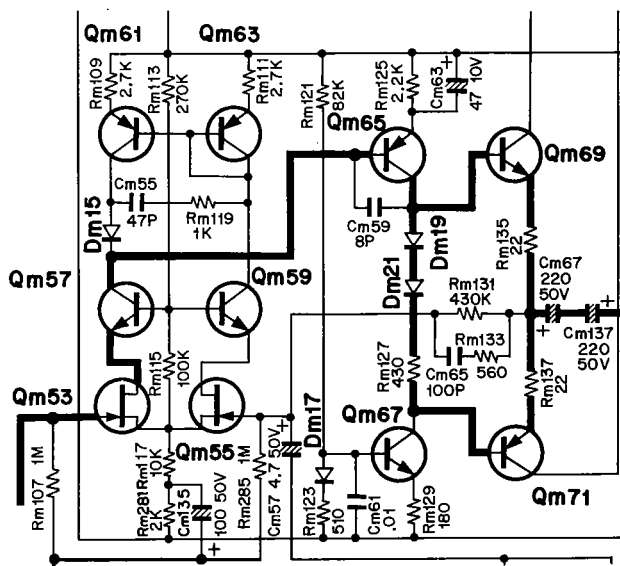

The tone amplifier's configuration is the same as the equalizer amplifier for the MM-type cartridge without the emitter follower circuit of the second stage. This is the NF-type one. The amplifier works as a flat amplifier with 23 dB gain at the middle point of a tone control attenuator. The model L-07C is designed so that the signal will saturate at the final stage of the tone amplifier if the signal of an excessive level is fed.

The treble function works by selecting the resistors and the bass function works by selecting the inserted NF components as shown in the illustrations.

Treble

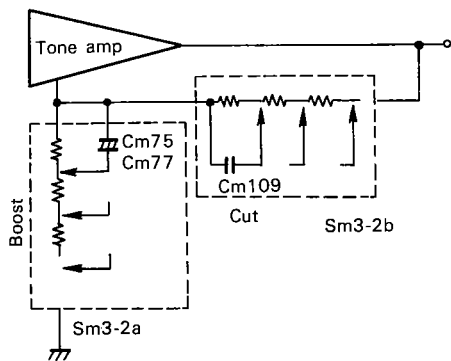

Bass (boost)

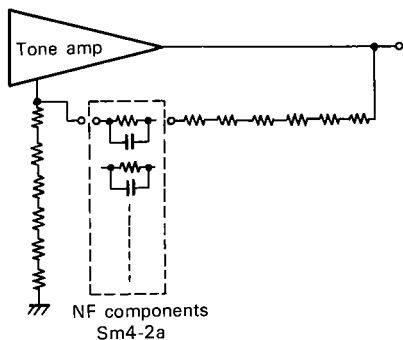

Bass (cut)

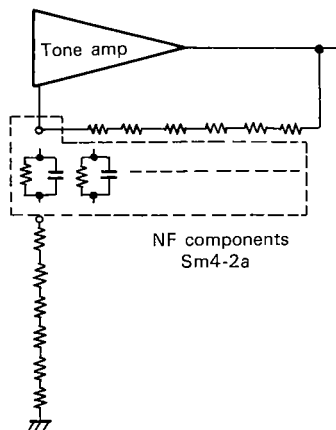

BUFFER AMPLIFIER

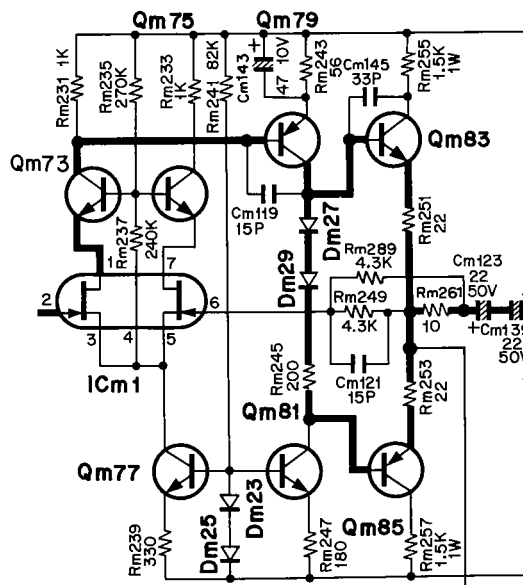

The first stage consists of the differential amplifier of μ PA-63H with the constant current circuit Qm77 and the cascode amplifier Qm73, 75. μ PA-63H is a dual type FET diffused on one chip.

For this reason, it is stable to the temperature change. The cascode amplifier is used not to supply the high voltage for FET. The constant current circuit is used to improve CMRR. The second stage consists of the class A amplifier Qm79 with the constant current circuit Qm81. Qm81 is used to increase the gain.

The final stage consists of SEPP Qm83, 85. This amplifier is used to lower the output impedance of the model L-07C. Its gain is 0 dB because the 100% of the output signal is negatively fed back to the input stage. (The one of the negative feedback resistors, which should be inserted between the gate of ICm1 and the ground, is eliminated.) Here, the output signal is fed back from before and behind of Rm261 to the input stage to reduce the influence of Rm261.

CIRCUIT DESCRIPTION

SUBSONIC FILTER

The output signal of the buffer amplifier is fed back via Cm113, 115, 117 and Rm227 to the input stage to cut the low frequency band of less than 18 Hz by 12 dB/oct.

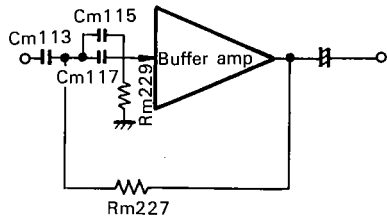

GAIN ATTENUATOR

This attenuator works as a volume controller of the model L-07M, a power amplifier. This reduces the residual noise because it is inserted after a master volume.

This is set so that the master volume will be at -20 dB position at ordinary use.

This attenuator is a ladder type. Its name is derived from the fact that the configuration is similar to a ladder laid in its side. The configuration of a ladder pot consists of group of pi-pads connected in tandem. The input and output impedances are constant throughout its complete range of attenuation. For this reason, the signal source impedance of the buffer amplifier is kept constant resulting in the ultra low distortion amplifier. Also it actualizes the excellent characteristics of the subsonic filter.

The ladder configurations have a fixed insertion loss of 6 dB.

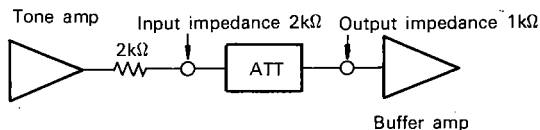
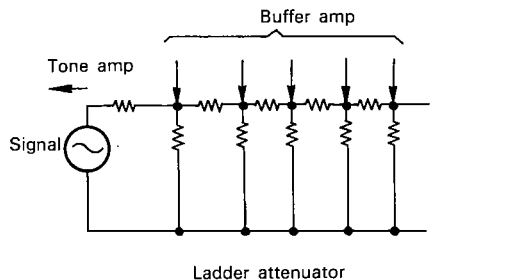

POWER SUPPLY

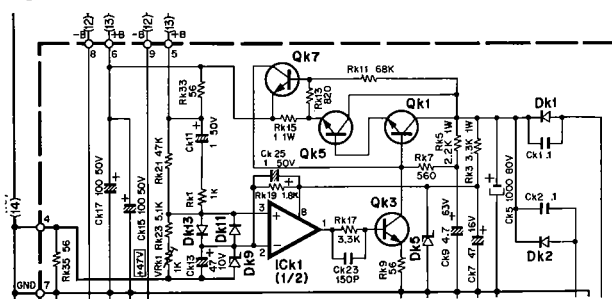

The power supply unit consists of the positive and negative voltage-regulator circuits and a relay driving circuit. Since the positive voltage-regulator circuit is same as the negative one, we describe the positive one only, here. It consists of the error amplifier ICk1, Qk3, the control circuit Qk1, 5 and the protection circuit Qk7.

The AC 50V is full-wave rectified by Dk1 and Dk2 resulting in the DC 61V. The DC output voltage is adjusted to 47V by VRk1. If the DC output voltage increases, the voltage of IC's No. 3 terminal will be larger than that of IC's No. 2 terminal, which is set at DC 5V as a standard voltage by Dk9, resulting in a rise of the voltage of IC's No. 8 terminal.

And Ic of Qk3 will increase for this reason with the result that it will lower the base voltage of Qk1. The voltage of Qk5's emitter will become low and it will negate the rise of the DC output voltage mentioned.

Qk7 prevents the circuit from a over current.

If the load current is over its pre-determined value, about 500mA, Qk7 will be turned on by the voltage drop of Rk15. And the base current will decrease reducing the load current so that the DC output voltage will become low.

If there is a short in the DC output circuit, Qk5 may be destroyed on account of being over its PC rating. Because the emitter voltage of Qk5. will be drawn to a 0V at the time. Rk11 is added to prevent Qk5 from the destruction. Rk11 raises the base voltage of Qk7 so that Qk7's Ic will increase hastily lowering the base voltage of Qk1. As a result Qk1 and Qk5 are prevented. Dk11, 13 are a limiter circuit preventing ICk1 from the destruction. The supply voltage for ICk1 is stabilized at ±14V by Dk5 and Dk6.

Then we explain about a relay driving circuit.

When the power is on, Qk9 turns on by the DC voltage rectified through Dk1. LED turns on with the result that the remote relay for a power amplifier turns on.

When LED is broken, a remote relay circuit does not work so that the shock noise will occur.

When the power is on, Qk11 and Qk12 turn on about 4 seconds after, and RLM1 and RLM2 turn on.

This time constant is determined by Ck21, Rk30, Rk31, and Rk32.

When the power is turned off, Ck20 is discharged, Qk9 turns off and Qk10 turns on.

Then Ck21 is discharged, Qk11 and Qk12 turn off and the relay turns off. The drift of the output voltage is detected at the audio unit in order to stabilize the output voltage perfectly.

CIRCUIT DESCRIPTION

OTHER

The performance of the circuit is improved by selecting a proper earth point. Since the unit is designed to provide stereo separation of more than 100 dB at 20 kHz, the sound image and positioning are excellent. The improvement in separation is attained by completely separating the L and R channels into two units and shielding them with a bus earth line, and also by shielding the rotary switch between the wafers. The earth terminal of the equalizer circuit can be connected to either the floating GND or the chassis GND, whichever the hum from the turntable is eliminated.

SERVICING AND CAUTIONS

Power Supply Unit (X00-1920-)

1. A hardware is used to supply $\pm B$ to the audio unit.

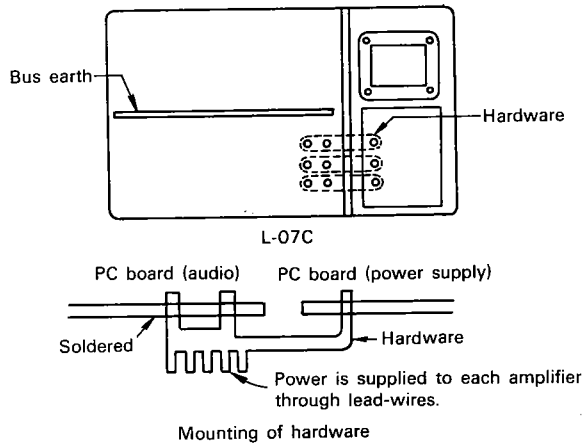

2. As described previously, the voltage is detected at the audio block. This assures the supply of stable voltage because the hardware has some impedance. In this way, the voltage fluctuation is as small as $20 \sim 40\mu V$ which is about the limit of voltage measured by VTVM.
3. To repair the power supply block, be sure to remove the fuse unit.
4. The standard voltage for EQA01-05S is between 4.7V and 5.3V. Adjustment of the voltage should be made using the diode specified. Do not use any other zener diode.
5. Note that only Qk9 ~ 12 are interchangeable with replacement semiconductors.

Audio Unit (X09-1210-)

1. The relays RLm1 and 2 are connected in series to supply +B, thus no power will be supplied when one relay becomes defective.
2. When replacing the rotary switch, proceed as follows: Remove the shaft from the rear side and unsolder all the wafers. Replace the defective wafer with a new one. The rotary switch cannot be replaced as a unit.

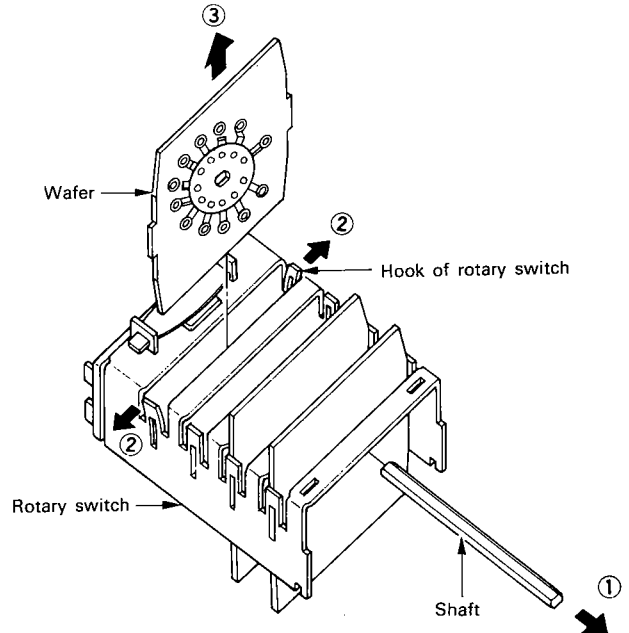

1. Pull out the rotary switch shaft. ①
2. Loose the hook fixing the wafer. ②
3. Pull out the defective wafer and replace with new one. ③
3. Measure DC voltages and check against the values noted in the schematic diagram. Check to be sure that the base voltage of the cascode circuit is not deviated excessively from the value noted. If this voltage differs largely from the specified value, the result is a distortion in the output.
4. If Qm65 ~ 68 become defective, the output will be distorted.
5. The transistors of MC equalizer amplifier cannot be replaced, except the one at the final stage. The FET's at the front stage are of N1 and N2 ranks respectively. These should be used as a matched pair.

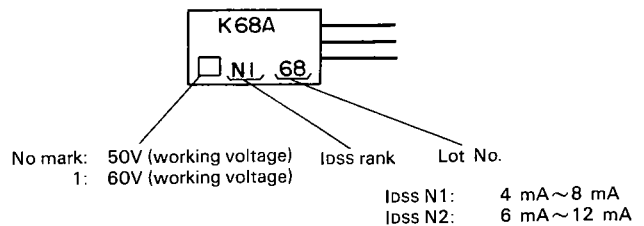

6. The heat sink of the tone amplifier will normally be heated to $60^{\circ}C$ because the current flowing into the amplifier is about the same as that flowing into the power amplifier.

DESTINATIONS' PARTS LIST

☆ : new parts

Ref. No.	U.S.A. (K)	Canada (P)	Europe (W)	Scandinavia (L)	England (T)	Other Areas (M)	Description
C1, 2, 3	C91-0001-05 x 2	C91-0025-05 x 2	CK45E3D103PMU x 3	CK45E3D103PMU x 3	CK45E3D103PMU x 3	C91-0023-05 x 2	Ceramic capacitor 0.01μF
—	A20-1134-02	A20-1134-02	A20-1134-02	A20-1134-02	A20-1133-02	A20-1134-02	Panel ass'y ☆
—	B46-0061-10	B46-0055-20	—	—	B46-0060-00	—	Warranty card
—	B50-1612-00	B50-1613-00	B50-1612-00	B50-1612-00	B50-1614-00	B50-1612-00	Instruction manual ☆
—	B59-0084-00	B59-0084-00	B59-0084-00	B59-0084-00	—	B59-0084-00	Guide book
—	—	—	D32-0075-04	—	—	D32-0075-04	Switch stopper
—	E08-0225-05 x 4	E08-0225-05 x 4	—	—	—	E08-0225-05 x 3	AC outlet
—	E30-0181-05	E30-0181-05	E30-0459-05	E30-0292-05	040-0306-05	E30-0545-05	Power cord
—	H01-1695-04	H01-1697-04	H01-1695-04	H01-1695-04	H01-1696-04	H01-1695-04	Carton case (inside) ☆
—	—	H03-0565-04	—	—	—	—	Carton case (outside) ☆
—	H20-0394-04	H20-0394-04	H20-0394-04	H20-0394-04	H20-0394-04	H20-0416-04	Polyethylene cover
—	—	—	—	—	—	H40-0004-04	Anti-rust paper
—	J02-0088-05	J02-0089-05	J02-0089-05	J02-0089-05	J02-0089-05	J02-0089-05	Leg x 4
—	J41-0034-05	J41-0034-05	J41-0033-05	J41-0033-05	J41-0024-15	J41-0034-05	Power cord bushing
—	—	—	—	J61-0038-05	J61-0038-05	—	Cord band
—	L01-1291-05	L01-1291-05	L01-1296-05	L01-1292-05	L01-1297-05	L01-1295-05	Power transformer ☆
S1	S33-2022-05	S33-2022-05	S33-2023-05	S33-2023-05	S33-2023-05	S33-2021-05	Power switch
—	—	—	S31-2001-05	—	—	S31-2001-05	Slide switch (power voltage selector)
—	X00-1920-11	X00-1921-01	X00-1921-71	X00-1921-71	X00-1921-71	X00-1921-01	Power supply unit ☆
—	X09-1210-11	X09-1211-01	X09-1211-01	X09-1211-01	X09-1211-01	X09-1211-01	Audio unit ☆
—	X13-2470-11	X13-2470-11	X13-2470-61	X13-2470-51	X13-2470-51	X13-2470-21	Fuse unit ☆

PARTS LIST

Symbol ☆ : New parts

Ref. No.	Parts No.	Description	Re- marks
CAPACITOR			
C4	CK45F1H403Z	Ceramic 0.04μF +80%—20%	
SEMICONDUCTOR			
D1	V11-0404-05	LED (GD-4-207RD)	
SWITCH			
S2	S40-2079-05	Pushbutton switch OUTPUT	☆
MISCELLANEOUS			
—	A01-0314-12	Case	☆
—	B07-0208-04	Escutcheon for power switch	☆
—	B07-0209-04	Ring for subsonic switch	☆
—	B07-0210-04	Ring for output switch	☆
—	B42-0009-04	Passed sticker	
—	D19-0050-14	Backplate	
—	D21-0438-14	Shaft (A) × 3	☆
—	D21-0439-04	Shaft (B) for pushbutton switch	☆
—	D21-0440-13	Shaft for double axes	☆
—	D21-0444-14	Shaft (A) × 2	☆
—	D22-0031-04	Coupler × 5	
—	E03-0006-05	Connector for remote operation × 2	☆
—	E13-0115-05	Phono jack 1P with lock × 2	
—	E13-0808-05	Phono jack 8P	☆
—	E13-0809-05	Phono jack 8P (4P with gold-plated)	☆
—	E14-0001-05	Phono plug for audio cable × 4	
—	E14-0107-05	Short-circuit pin plug × 6	
—	E21-0149-05	Terminal × 2	
—	E23-0015-04	Terminal	
—	E23-0099-04	Junction terminal × 3	☆
—	E31-0063-05	Cord with 2P connector	☆
—	E31-0066-05	Mini-connector ass'y (3P, three-parallel cord)	☆
—	E31-0067-05	Mini-connector ass'y (3P, three-parallel cord)	☆
—	E31-0068-05	Mini-connector ass'y (3P, two-conductor cord)	☆
—	E31-0069-05	Mini-connector ass'y (3P, two-conductor cord)	☆
—	E31-0070-05	Mini-connector ass'y (3P + 3P, ten-parallel cord)	☆
—	E31-0072-05	Mini-connector ass'y (6P, two-conductor cord × 2)	☆
—	E31-0073-05	Mini-connector ass'y (6P, two-conductor cord × 2)	☆
—	G01-0312-04	Spring for subsonic switch	
—	H12-0057-03	Buffer fixture	☆
—	H12-0058-03	Buffer fixture	☆
—	H12-0062-04	Buffer fixture	☆
—	H25-0029-04	Polyethylene bag (60 × 110)	
—	H25-0078-00	Instruction bag	
—	H25-0097-04	Polyethylene bag × 2	
—	J42-0067-04	Lamp bushing	
—	K21-0333-14	Knob (BASS, TREBLE) × 2	☆
—	K21-0334-14	Knob (MASTER VOLUME, TAPE, INPUT SELECTOR) × 3	☆
—	K21-0335-14	Knob (GAIN ATT inside)	☆
—	K21-0336-14	Knob (GAIN ATT outside)	☆
—	K27-0053-04	Knob (POWER)	☆
—	K27-0054-04	Knob (SUBSONIC)	☆
—	K27-0055-04	Knob (OUTPUT)	☆
—	W01-0077-15	Hexagon wrench	
—	050-2005-05	Two-conductor cable for audio cable	

POWER SUPPLY (X00-1920-)

Ref. No.	Parts No.	Description	Re- marks
CAPACITOR			
Ck1-4	C91-0036-05	Mylar 0.1μF 250WV	
Ck5,6	C90-0353-05	Electrolytic-block 1000μF 80WV	☆
Ck7,8	CE04W1C470EL	Electrolytic 47μF 16WV	
Ck9,10	CE04W1J4R7EL	Electrolytic 4.7μF 63WV	
Ck11,12	CE04W1H010EL	Electrolytic 1μF 50WV	
Ck13,14	CE04W1A470EL	Electrolytic 47μF 10WV	
Ck15-18	CE04W1H101EL	Electrolytic 100μF 50WV	
Ck19	CK45E2H103PMU	Ceramic 0.01μF +100%—0%	
Ck20	CE04AW1E220MEL	Electrolytic 22μF 25WV	
Ck21	CE04AW1E470MEL	Electrolytic 47μF 25WV	
Ck22,23	CC45SL1H151K	Ceramic 150pF ±10%	
RESISTOR			
Rk1,2	RD14GY2E102JMA	Flame-proof carbon 1kΩ ±5% 1/4W	
Rk3,4	RS14GB3A332JMA	Flame-proof oxide metal film 3.3kΩ ±5% 1W	
Rk5,6	RS14GB3A222JMA	Flame-proof oxide metal film 2.2kΩ ±5% 1W	
Rk15,16	RS14GB3A1R0JMA	Flame-proof oxide metal film 1kΩ ±5% 1W	
Rk25	RS14GB3A152JMA	Flame-proof oxide metal film 1.5kΩ ±5% 1W	
Rk38	RS14GB3A221JMA	Flame-proof oxide metal film 220Ω ±5% 1W	
Rk39	RS14GB3D222JMA	Flame-proof oxide metal film 2.2kΩ ±5% 2W	
Rk40	RS14GB3A470JMA	Flame-proof oxide metal film 47Ω ±5% 1W	
SEMICONDUCTOR			
Qk1	V03-0460-05	Transistor 2SC1904(G) or (B)	
Qk2	V01-0199-05	Transistor 2SA899(G) or (B)	
Qk3	V03-0460-05	Transistor 2SC1904(G) or (B)	
Qk4	V01-0199-05	Transistor 2SA899(G) or (B)	
Qk5	V04-0078-05	Transistor 2SD525	
Qk6	V02-0059-05	Transistor 2SB595	
Qk7	V03-0215-05	Transistor 2SC1213A(B) or (C)	
Qk8-10	V01-0073-05	Transistor 2SA673A(B) or (C)	
Qk11	V01-0191-05	Transistor 2SA872	
Qk12	V01-0173-05	Transistor 2SA850(D) or (E)	
ICk1	V30-0088-05	IC RC4558T	
Dk1-4	V11-0200-05	Diode V06C	
Dk5,6	V11-0254-05	Zener diode YZ-140	
Dk9,10	V11-0462-05	Zener diode EQA01-05S	
Dk11-14	V11-0271-05	Diode 1S2076	
Dk15	V11-0200-05	Diode V06C	
Dk16	V11-0435-05	Zener diode EQA01-24R	
Dk17	V41-0271-05	Diode 1S2076	
Dk18	V11-0271-05	Diode 1S2076 (-1921-71)	
MISCELLANEOUS			
VRk1,2	S12-1029-05	Semi-fixed resistor 1kΩ VOLTAGE ADJUSTMENT	
RLk1	S51-1022-05	Reed relay HA124S (12V)	
RLk2	S51-1021-05	Relay	

AUDIO (X09-1210-)

* These resistors are used in the units of W, L and T.
For K, P and M the normal carbon resistors are used instead.

Ref. No.	Parts No.	Description	Re- marks
Cm3,4	CC45SL1H330K	Ceramic 33pF ±10%	
Cm5,6	CC45SL1H220K	Ceramic 22pF ±10%	
Cm7,8	CE04W1A331EL	Electrolytic 330μF 10WV	
Cm9,10	CQ93M1H822G	Mylar 0.0082μF ±2%	
Cm11,12	CQ93M1H392G	Mylar 0.0039μF ±2%	
Cm13,14	CQ93M1H562G	Mylar 0.0056μF ±2%	
Cm15,16	CC45SL1H270K	Ceramic 27pF ±10%	

PARTS LIST

Ref. No.	Parts No.	Description	Re- marks
Cm17,18	CE04W1A101EL	Electrolytic 100μF 10WV	
Cm19-22	CC45SL1H470K	Ceramic 47μF ±10%	
Cm23-28	CE04W1H100EL	Electrolytic 10μF 50WV	
Cm31,32	CC45SL1H151K	Ceramic 150pF ±10%	
Cm33,34	CE04W1A102EL	Electrolytic 1000μF 10WV	
Cm35,36	CC45SL1H070D	Ceramic 7pF ±0.5pF	
Cm37,38	CE04W1A101EL	Electrolytic 100μF 10WV	
Cm39-42	CC45SL1H101K	Ceramic 100pF ±10%	
Cm43,44	C91-0035-05	Mylar 0.056μF ±2%	☆
Cm45,46	C91-0034-05	Mylar 0.015μF ±2%	☆
Cm47,48	CQ09FS1H821G	Polystyrene 820pF ±2%	
Cm49,50	CE04W1H100EL	Electrolytic 10μF 50WV	
Cm51-54	CE04W1H101EL	Electrolytic 100μF 50WV	
Cm55,56	CC45SL1H470K	Ceramic 47pF ±10%	
Cm57,58	CE04W1H4R7EL	Electrolytic 4.7μF 50WV	
Cm59,60	CC45SL1H080D	Ceramic 8pF ±0.5pF	
Cm61,62	CQ93M1H103K	Mylar 0.01μF ±10%	
Cm63,64	CE04W1A470EL	Electrolytic 47μF 10WV	
Cm65,66	CC45SL1H101K	Ceramic 100pF ±10%	
Cm67,68	CE04W1H221EL	Electrolytic 220μF 50WV	
Cm69-72	CE04W1H101EL	Electrolytic 100μF 50WV	
Cm73,74	CC45SL1H101K	Ceramic 100pF ±10%	
Cm75,76	CS15E1VR33K	Tantalum 0.33μF 35WV	
Cm77,78	CS15E1VR68K	Tantalum 0.68μF 35WV	
Cm79,80	CS15E0J330K	Tantalum 33μF 6.3WV	
Cm81,82	CS15E0J100K	Tantalum 10μF 6.3WV	
Cm83,84	CS15E1VR15K	Tantalum 0.15μF 35WV	
Cm85-88	CS15E1C2R2K	Tantalum 2.2μF 16WV	
Cm89,90	CS15E1E010K	Tantalum 1μF 25WV	
Cm91,92	CS15E1VR33K	Tantalum 0.33μF 35WV	
Cm93,94	CS15E0J4R7K	Tantalum 4.7μF 6.3WV	
Cm95,96	CS15E1VR47K	Tantalum 0.47μF 35WV	
Cm97,98	CQ93M1H563K	Mylar 0.056μF ±10%	
Cm99,100	CS15E1VR33K	Tantalum 0.33μF 35WV	
Cm101,102	CS15E1C2R2K	Tantalum 2.2μF 16WV	
Cm103,104	CS15E1VR68K	Tantalum 0.68μF 35WV	
Cm105,106	CS15E1VR33K	Tantalum 0.33μF 35WV	
Cm107,108	CS15E1VR15K	Tantalum 0.15μF 35WV	
Cm109,110	CQ93M1H683J	Mylar 0.068μF ±5%	
Cm111,112	CE04W1A102EL	Electrolytic 1000μF 10WV	
Cm113,114	CQ93M1H224J	Mylar 0.22μF ±5%	
Cm115,116	CQ93M1H562J	Mylar 0.0056μF ±10%	
Cm117,118	CQ93M1H823J	Mylar 0.082μF ±5%	
Cm119-122	CC45SL1H150K	Ceramic 15pF ±5%	
Cm123,124	CE04W1H220EL	Electrolytic 22μF 50WV	
Cm125-128	CE04W1H101EL	Electrolytic 100μF 50WV	
Cm129,130	CE04W1H010EL	Electrolytic 1μF 50WV	
Cm131-136	CE04W1H101EL	Electrolytic 100μF 50WV	
Cm137,138	CE04W1H221EL	Electrolytic 220μF 50WV	
Cm139,140	CE04W1H220EL	Electrolytic 22μF 50WV	
Cm141,142	CC45SL1H270K	Ceramic 27pF ±10%	
Cm143,144	CE04W1A470EL	Electrolytic 47μF 10WV	
Cm145,146	CC45SL1H330K	Ceramic 33pF ±10%	
Cm147,148	CK45E2H103P	Ceramic 0.01μF ±100% -0%	
Cm149,150	CC45SL1H391K	Ceramic 390pF ±10%	
Cm151,152	CC45SL1H151K	Ceramic 150pF ±10%	
Cm153,154	CC45SL1H101K	Ceramic 100pF ±10%	

RESISTOR

Rm19,20	RS14GB3A472JMA	Flame-proof oxide metal film 4.7kΩ ±5% 1W	
Rm31,32	RN14BK2H3833F	Metal film 383kΩ ±1% 1/2W	
Rm33,34	RN14BK2H3242F	Metal film 32.4kΩ ±1% 1/2W	
Rm37,38	RD14GY2E681JMA	Flame-proof carbon 680Ω ±5% 1/4W	*
Rm39,40	RD14GY2E152JMA	Flame-proof carbon 1.5kΩ ±5% 1/4W	*
Rm45-48	RS14GB3A102JMA	Flame-proof oxide metal film 1kΩ ±5% 1W	
Rm75,76	RD14GY2E471JMA	Flame-proof carbon 470Ω ±5% 1/4W	*
Rm79,80	RD14GY2E182JMA	Flame-proof carbon 1.8kΩ ±5% 1/4W	*
Rm81,82	RN92BC2E563F	Metal film 56kΩ ±1% 1/4W	
Rm83,84	RN92BC2E821F	Metal film 820Ω ±1% 1/4W	
Rm85,86	RN92BC2E472F	Metal film 4.7kΩ ±1% 1/4W	
Rm87,88	RN92BC2E560F	Metal film 56Ω ±1% 1/4W	
Rm97-100	RS14GB3A221JMA	Flame-proof oxide metal film 220Ω ±5% 1W	
Rm125,126	RD14GY2E222JMA	Flame-proof carbon 2.2kΩ ±5% 1/4W	*
Rm127,128	RD14GY2E431JMA	Flame-proof carbon 430Ω ±5% 1/4W	*

Ref. No.	Parts No.	Description	Re- marks
Rm243,244	RD14GY2E560JMA	Flame-proof carbon 56Ω ±5% 1/4W	*
Rm245,246	RD14GY2E201JMA	Flame-proof carbon 200Ω ±5% 1/4W	*
Rm255-258	RS14GB3G152JMA	Flame-proof oxide metal film 1.5kΩ ±5% 1W	*
Rm269-272 281,282	RD14GY2E202JMA	Flame-proof carbon 2kΩ ±5% 1/4W	*

SEMICONDUCTOR

Qm1-8	V09-0094-05	FET 2SK68A(N1) or (N2)	
Qm9-12	V03-0500-05	Transistor 2SC1775(D) or (E)	
Qm13-18	V01-0191-05	Transistor 2SA872(D) or (E)	
Qm19-24	V01-0200-05	Transistor 2SA872A(Q) or (E)	
Qm25,26	V03-0501-05	Transistor 2SC1775A(D) or (E)	
Qm27,28	V03-0460-05	Transistor 2SC1904(B) or (V)	
Qm29,30	V01-0199-05	Transistor 2SA899(B) or (V)	
Qm31-34	V09-0094-05	FET 2SK68A(N)	
Qm35-38	V03-0500-05	Transistor 2SC1775(D) or (E)	
Qm39-42	V01-0191-05	Transistor 2SA872(D) or (E)	
Qm43,44	V01-0200-05	Transistor 2SA872A(Q) or (E)	
Qm45,46	V03-0460-05	Transistor 2SC1904(B) or (V)	
Qm47,48	V01-0199-05	Transistor 2SA899(B) or (V)	
Qm49,50	V03-0468-05	Transistor 2SC1913(Q) or (R)	
Qm51,52	V01-0188-05	Transistor 2SA913(Q) or (R)	
Qm53-56	V09-0094-05	FET 2SK68A(N)	
Qm57-60	V03-0500-05	Transistor 2SC1755(D) or (E)	
Qm61-64	V01-0191-05	Transistor 2SA872(D) or (E)	
Qm65,66	V01-0199-05	Transistor 2SA899(B) or (V)	
Qm67,68	V03-0460-05	Transistor 2SC1904(B) or (V)	
Qm69,70	V03-0468-05	Transistor 2SC1913(Q) or (R)	
Qm71,72	V01-0188-05	Transistor 2SA913(Q) or (R)	
Qm73-78	V03-0500-05	Transistor 2SC1775(D) or (E)	
Qm79,80	V01-0199-05	Transistor 2SA899(B) or (V)	
Qm81,82	V03-0460-05	Transistor 2SC1904(B) or (V)	
Qm83,84	V03-0468-05	Transistor 2SC1913(Q) or (R)	
Qm85,86	V01-0188-05	Transistor 2SA913(Q) or (R)	
ICm1,2	V30-0232-05	IC μPA-63H(L)	
Dm1-4	V11-0271-05	Diode 1S2076	
Dm5-8	V11-0319-05	Varistor M8513A-0	
Dm9,10	V11-0271-05	Diode 1S2076	
Dm11-14	V11-0319-05	Varistor M8513A-0	
Dm15-18	V11-0271-05	Diode 1S2076	
Dm19-22	V11-0319-05	Varistor M8513A-0	
Dm23-26	V11-0271-05	Diode 1S2076	
Dm27-30	V11-0319-05	Varistor M8513A-0	
Dm31,32	V11-0271-05	Diode 1S2076	

MISCELLANEOUS

VRm1	R10-4001-15	Attenuator 50kΩ MASTER VOLUME	☆
VRm2	R23-1001-05	Attenuator 2kΩ GAIN ATT	☆
RLm1,2	S51-1021-05	Relay G2E (24V)	☆
Sm1	S01-4025-05	Rotary switch (INPUT SELECTOR)	☆
Sm2	S01-4026-05	Rotary switch (TAPE)	☆
Sm3	S01-2044-05	Rotary switch (TREBLE)	☆
Sm4	S01-2045-05	Rotary switch (BASS)	☆
Sm5	S40-6011-05	Pushbutton switch (SUBSONIC)	☆
-	E40-0341-05	Mini-connector ass'y (3P, gold-plated) × 4	☆
-	E40-0370-05	Mini-connector ass'y (3P) × 2	
-	E40-0670-05	Mini-connector ass'y (6P) × 2	
-	F01-0210-04	Heat sink × 8	

FUSE (X13-2470-)

Ref. No.	Parts No.	Description	Re- marks
Fh1	F05-1021-05	Fuse 1A (-2470-11)	
	F05-1023-05	Fuse 1A (-2470-21)	
	F05-5016-05	Fuse 500m AT (-2470-51)	
	F06-1022-05	Fuse 1 AT (-2470-61)	
Fh2	F05-5013-05	Fuse 0.5A (-2470-21)	
	F05-5016-05	Fuse 500m AT (-2470-61)	
-	J13-0052-05	Fuse clip	

ADJUSTMENT/PC BOARD/MODIFICATION SCHEMATIC

ADJUSTMENT OF VOLTAGE REGULATOR CIRCUIT

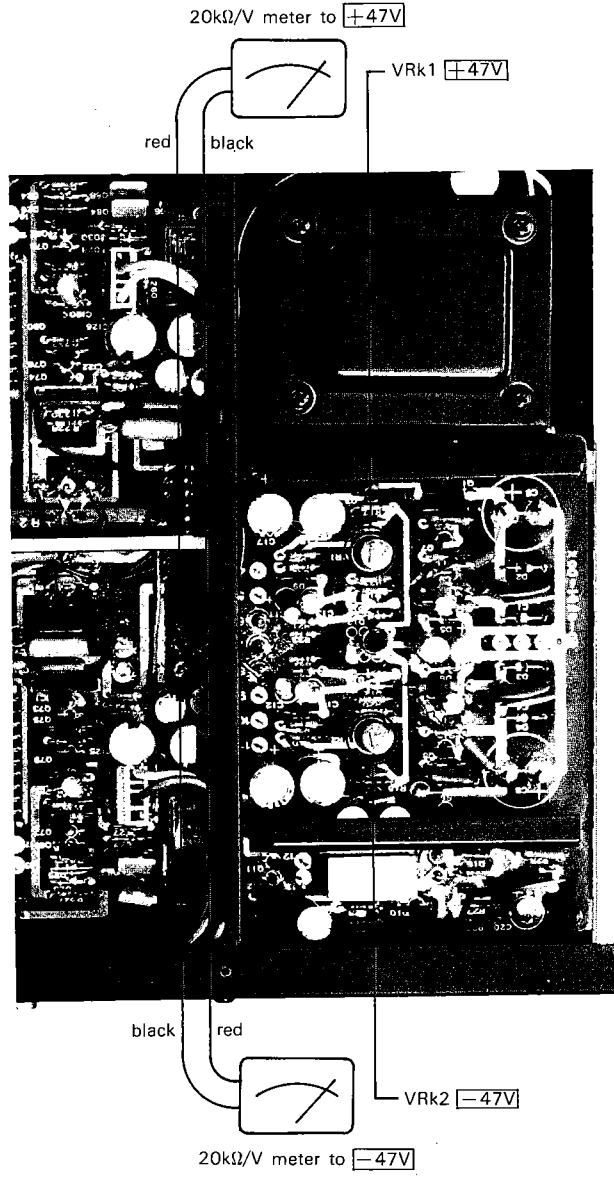

POWER SUPPLY (X00-1920-11)

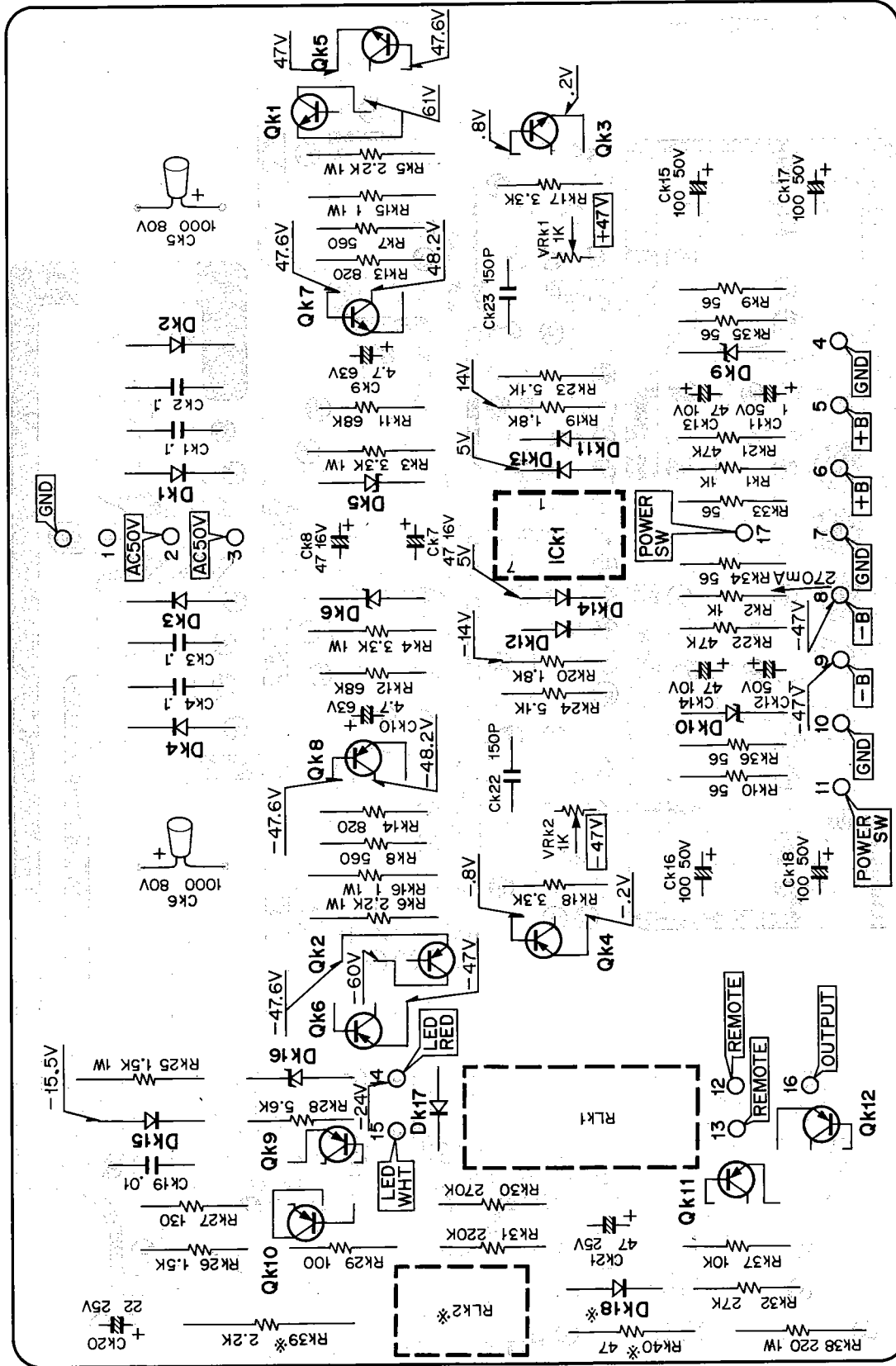

MODIFICATION SCHEMATIC

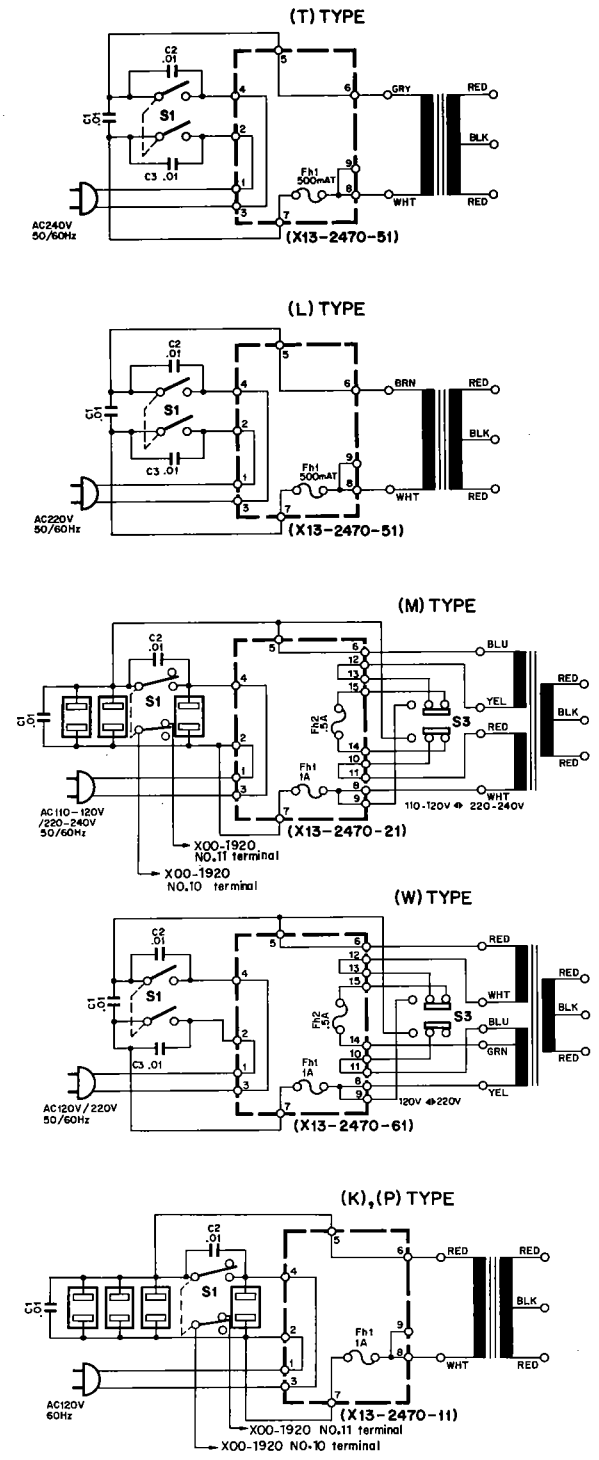

S1: POWER
S3: POWER VOLTAGE

- 2SA850
- 2SA777
- 2SA872
- 2SA912
- 2SC1775
- 2SA899
- 2SC1904
- 2SA673A
- 2SC1213A
- 2SA913
- 2SB536
- 2SB595
- 2SC1913
- 2SD381
- 2SD525

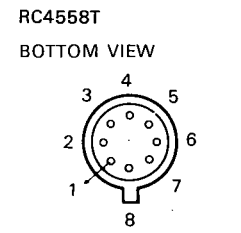

CK1.3: 2SC1904(G) or (B), QK2.4: 2SA899(G) or (B), QK5: 2SD525, QK6: 2SB595, QK7: 2SC1213A(B) or (C), QK8~10: 2SA673A(B) or (C), QK11: 2SA872, QK12: 2SA850(D) or (E),
ICK1: RC4558T, DK1~4, 15: V06C, DK5.6: YZ-140, DK9, 10: EQA01-05S, DK11~14, 17, 18: 1S2076, DK16: EQA01-24R

* For W, L and T type.

PC BOARD/SEMICONDUCTORS' SUBSTITUTIONS/MODIFICATION SCHEMATIC

AUDIO (X09-1210-11)

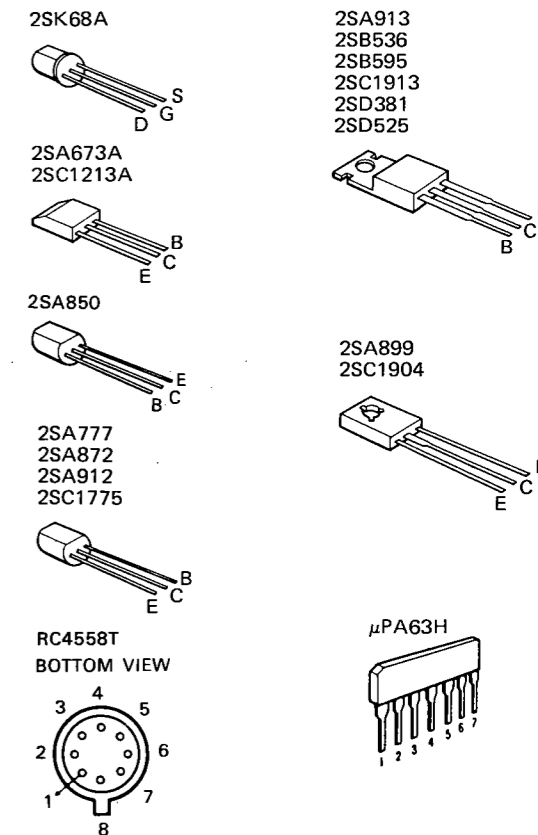
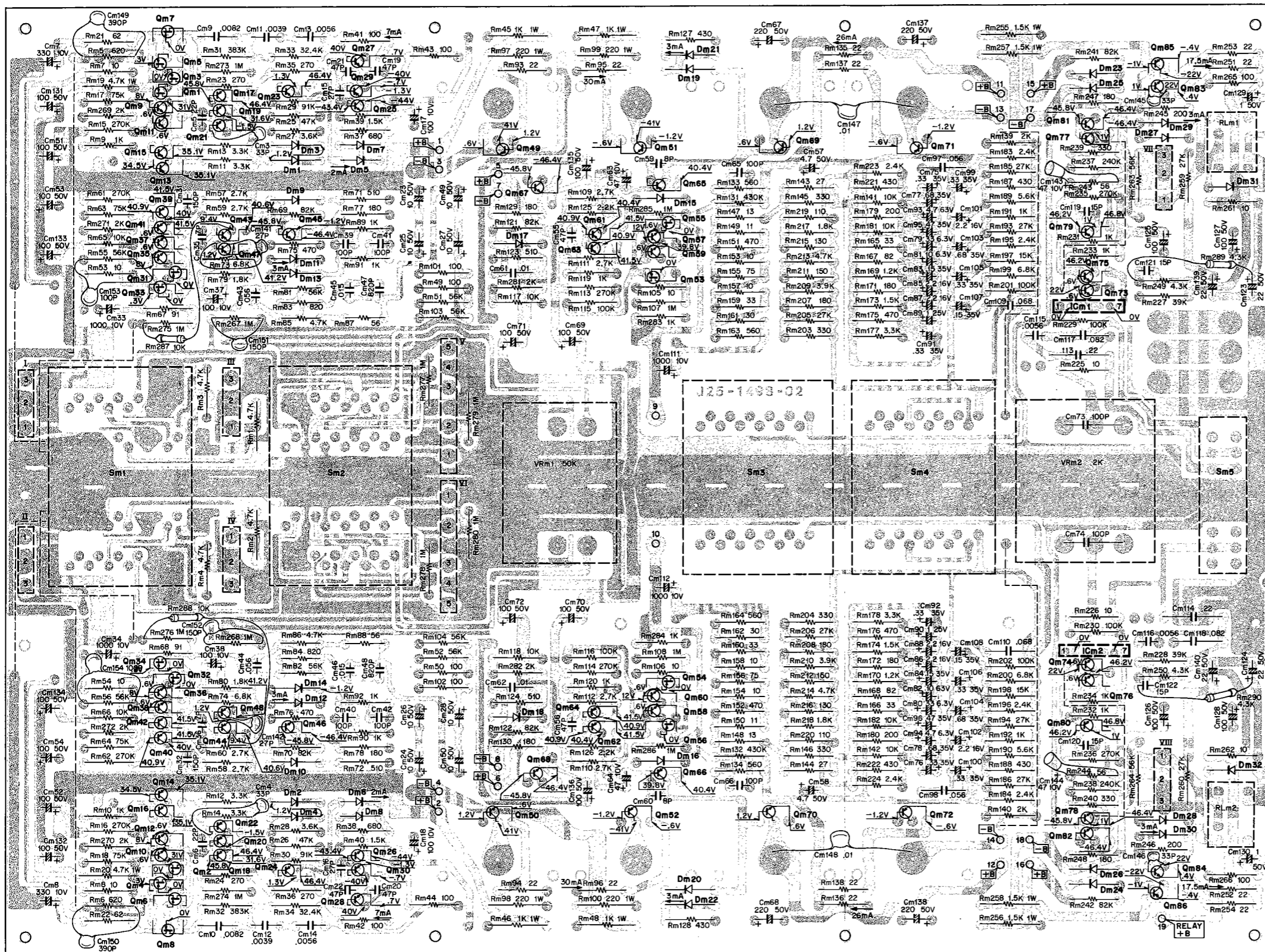

Semiconductors	Substitutions
AUDIO (X09-1210-)	
2SC1913(Q), (R)	2SD381(2)
2SA913(Q), (R)	2SB536(2)
POWER SUPPLY (X00-1920-)	
2SA673(B) or (C); Qk9, 10	2SA850, 2SA777
2SA850(D), (E)	2SA777, 2SA912

MODIFICATION SCHEMATIC for W, L and T type

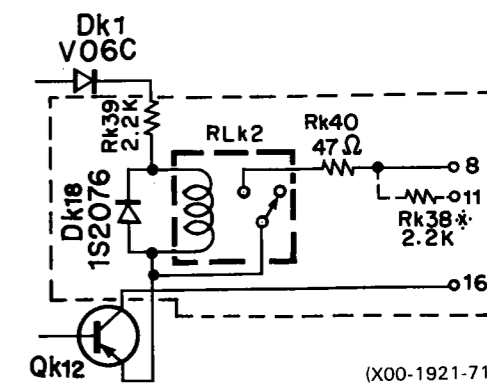

Qm1~8.31~34.35~56: 2SK68A(N), Qm9~12.35~38.57~60.73~78: 2SC1775(D) or (E), Qm13~18.39~42.61~64: 2SA872(D) or (E), Qm19~24.43.44: 2SA872A(D) or (E), Qm25.26: 2SC1775A(D) or (E), Qm27.28.45.46.67.68.81.82: 2SC1904(B) or (V), Qm29.30.47.48.65.66.79.80: 2SA899(B) or (V), Qm49.50.69.70.83.84: 2SC1913(Q) or (R), Qm51.52.71.72.85.86: 2SA913(Q) or (R), ICm1.2: μPA-63H(L), Dm1~4.9.10.15~18.23~26.31.32: 1S2076, Dm5~8.11~14.19~22.27~30: M8513A-O

NOTE: The power supply unit for W, L and T type is modified from (X00-1920-11) to (X00-1921-71). The modifications are inside the way line. Rk38 is eliminated. And the wiring for No. 11 and No. 17 terminals to S1 ~ 2 are eliminated. This circuit works as a shock noise eliminator when the power is off.

SCHEMATIC DIAGRAM

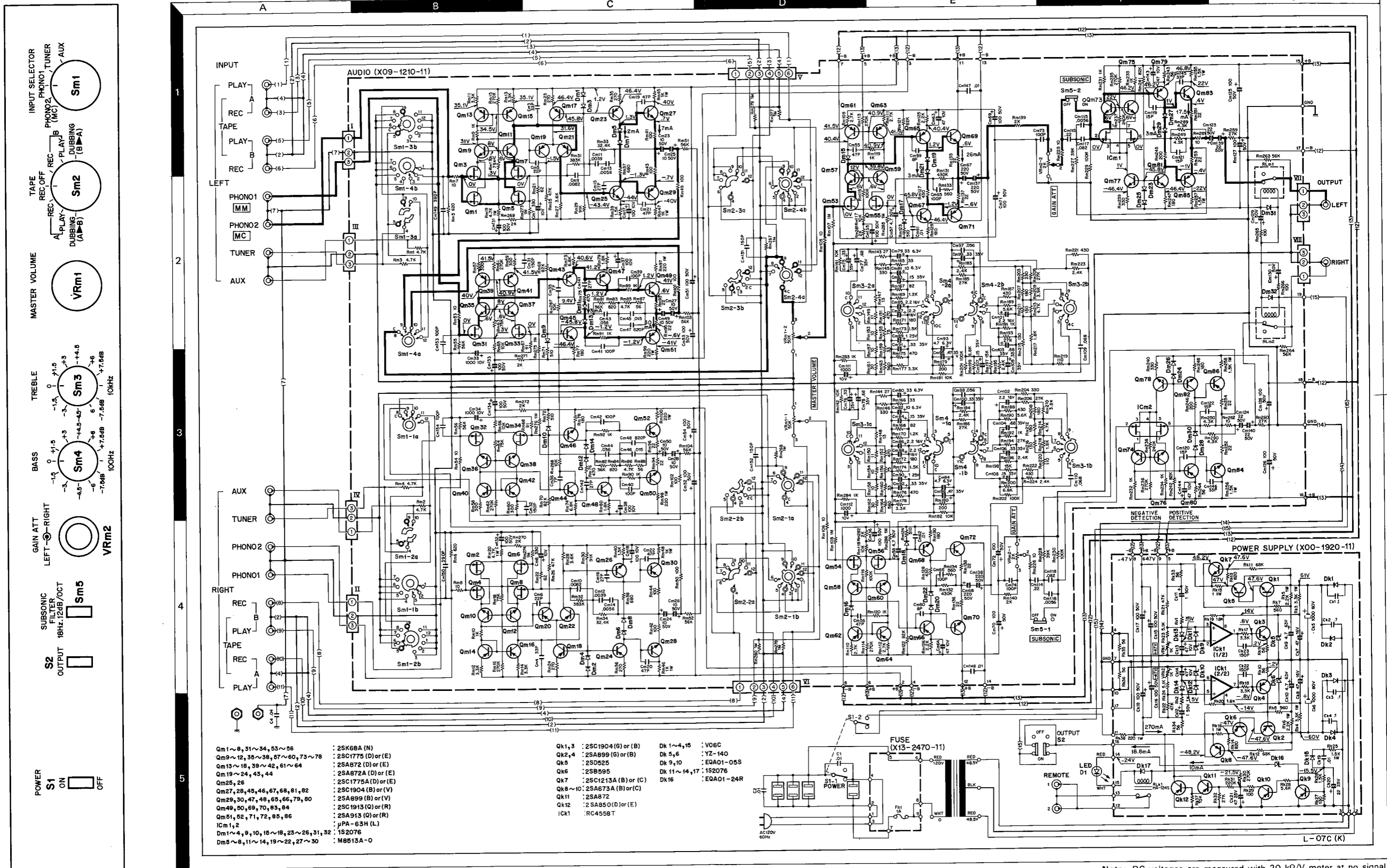

INPUT SELECTOR
PHONO2, PHONO1, TUNER, AUX

TAPE REC OFF, REC, PLAY, B, A, PHONO2, PHONO1, TUNER, AUX

MASTER VOLUME

TREBLE

BASS

GAIN ATT LEFT, RIGHT

SUBSONIC FILTER 18Hz, 12dB/OCT

S2 OUTPUT

POWER S1 ON, OFF

- | | | | | | |
|------------------------------------|-----------------------|--------|-----------------------|--------------|-------------|
| Qm1~8, 31~34, 53~56 | : 2SK68A (N) | Qk1, 3 | : 2SC1904 (G) or (B) | Dk 1~4, 15 | : V06C |
| Qm9~12, 35~38, 57~60, 73~78 | : 2SC1775 (D) or (E) | Qk2, 4 | : 2SA899 (G) or (E) | Dk 5, 6 | : YZ-140 |
| Qm13~18, 39~42, 61~64 | : 2SA872 (D) or (E) | Qk5 | : 2SD525 | Dk 9, 10 | : EQA01-05S |
| Qm19~24, 43, 44 | : 2SA872A (D) or (E) | Qk6 | : 2SB595 | Dk 11~14, 17 | : 1S2076 |
| Qm25, 26 | : 2SC1775A (D) or (E) | Qk7 | : 2SC1213A (B) or (C) | Dk16 | : EQA01-24R |
| Qm27, 28, 45, 46, 67, 68, 81, 82 | : 2SC1904 (B) or (V) | Qk8~10 | : 2SA673A (B) or (C) | | |
| Qm29, 30, 47, 48, 65, 66, 79, 80 | : 2SA899 (B) or (V) | Qk11 | : 2SA872 | | |
| Qm49, 50, 69, 70, 83, 84 | : 2SC1913 (Q) or (R) | Qk12 | : 2SA850 (D) or (E) | | |
| Qm51, 52, 71, 72, 85, 86 | : 2SA913 (Q) or (R) | ICK1 | : RC4558T | | |
| ICm1, 2 | : μ PA-63H (L) | | | | |
| Dm1~4, 9, 10, 15~18, 23~26, 31, 32 | : 1S2076 | | | | |
| Dm5~8, 11~14, 19~22, 27~30 | : M8513A-0 | | | | |

Note: DC voltages are measured with 20 k Ω /V meter at no signal.

SPECIFICATIONS

Specifications described here are based on the measured values at the tip of special 12-meter audio cable provided, at its connection to the output terminal of Model L-07C.

PERFORMANCE

Input Sensitivity/Impedance/Signal to Noise Ratio (IHF A Curve)	
Phono 1 (for MM use)	2.0 mV/50k ohms/83 dB
Phono 2 (for MC use)	0.2 mV/600 ohms/65 dB
Tuner	140 mV/50k ohms/110 dB
AUX	140 mV/50k ohms/110 dB
Tape Play	140 mV/50k ohms/110 dB
Maximum Input Voltage for Phono 1	350 mV (rms), T.H.D. 0.003% at 1,000 Hz
Maximum Input Voltage for Phono 2	35 mV (rms), T.H.D. 0.009% at 1,000 Hz
Frequency Response	
RIAA Standard Curve	
Phono 1	±0.2 dB (20 Hz ~ 20 kHz)
Phono 2	±0.2 dB (50 Hz ~ 20 kHz)
	−0.8 dB (20 Hz)
Tuner, AUX and Tape Play	20 Hz ~ 50 kHz (+0 dB, −0.1 dB)
	10 Hz ~ 200 kHz (+0 dB, −0.5 dB)
	3 Hz ~ 500 kHz (+0 dB, −2 dB)
Channel Separation	100 dB throughout 20 Hz ~ 20 kHz (short-circuited)
Tone Control	
BASS	±7.5 dB at 100 Hz
TREBLE	±7.5 dB at 10 kHz
Subsonic Filter	at 18 Hz, 12 dB (Octave)
Total Harmonic Distortion	
Tuner, AUX, Tape Play	0.003% at 1V (Output)
(20 Hz ~ 20 kHz)	0.005% at 7V (Output)
Phono 1 (20 Hz ~ 20 kHz)	0.003% at 1V (Output)
	[VOLUME at −20 dB and GAIN ATT at −10 dB]
Phono 2 (20 Hz ~ 20 kHz)	0.009% at 1V (Output)
	[VOLUME at −20 dB and GAIN ATT at −10 dB]
Output Voltage and Impedance	
Output	1V (less than 10 ohms)
Maximum Output	10V (less than 10 ohms)
Tape Rec	140 mV (100 ohms)
Load Impedance	50k ohm
Power Consumption	
Power Consumption	50 watts
AC Outlet	
AC Outlet	1 UNSWITCHED (100W max.)
	3 SWITCHED (300W max.)
Dimensions	
Dimensions	W 18-29/32" (480 mm)
	H 3-15/16" (100 mm)
	D 13-1/16" (332 mm)
Weight Net	
Weight Net	15.4 lbs. (7.0 kg)
Gross	18.2 lbs. (8.3 kg)

GENERAL

KENWOOD ELECTRONICS, INC.

- 15777 SOUTH BROADWAY, GARDENA, CALIFORNIA 90248 U.S.A.
- 75 SEAVIEW DRIVE SECAUCUS, NEW JERSEY 07094 U.S.A.

TRIO-KENWOOD ELECTRONICS N.V.

- LEUVENSESTEENWEG 184, B-1930 ZAVENTEM, BELGIUM.

TRIO-KENWOOD ELECTRONICS GmbH.

- 6056 HEUSENSTAMM, RUDOLF-BRAAS-STR. 20, WEST GERMANY.

TRIO-KENWOOD FRANCE S.A.

- 15, RUE PAUL BERT, 94200 IVRY-SUR-SEINE, PARIS, FRANCE.

TRIO-KENWOOD CORPORATION

- 3-6-17 AOBADAI, MEGURO-KU, TOKYO, JAPAN.