

D 101.11 :

- 5820-295-**DEPARTMENT OF THE ARMY TECHNICAL MANUAL**

**TM 11-5820-295-20**

20

**DEPARTMENT OF THE AIR FORCE TECHNICAL ORDER**

**TO 31R2-2GRC19-32**

# **ORGANIZATIONAL MAINTENANCE RADIO SET AN/GRC-19**



This copy is a reprint which includes current pages from Changes 1 through 6.

**DEPARTMENTS OF THE ARMY AND THE AIR FORCE**

**3 JUNE 1960**

UNIVERSITY OF VIRGINIA LIBRARY



Digitized by Google

**WARNING**

**DON'T TAKE CHANCES**

**EXTREMELY DANGEROUS VOLTAGES  
EXIST IN THE FOLLOWING UNIT  
OF RADIO SET AN/GRC-19**

**TRANSMITTER T-195/GRC-19**

**1,000-volts dc  
10,000-volts rf**





Organizational Maintenance  
RADIO SET AN/GRC-19

TM 11-5820-295-20 }  
TO 31R2-2GRC19-32 }  
CHANGES No. 1 }

DEPARTMENTS OF THE ARMY  
AND THE AIR FORCE  
WASHINGTON 25, D. C., 26 May 1961

TM 11-5820-295-20/TO 31R2-2GRC19-32, 3 June 1960, is changed as follows:

*Front cover.* Change TM number to read:  
TM 11-5820-295-20.

*Page 2, paragraph 1, subparagraph b(4), line 2.*  
Add to end of sentence: and transistorized audio  
module in some receivers.

*Subparagraph c.* Delete subparagraph *c* and  
substitute:

*c.* For differences between models of components  
comprising this radio set, refer to TM 11-806.

*Page 5, paragraph 1j.* Add to end of sentence:  
or transistorized audio module in some receivers.

*Page 9, paragraph 5a, caution notice.* Change  
the word *Caution:* to: *Cautions:* Number the  
existing caution 1 and add the following:

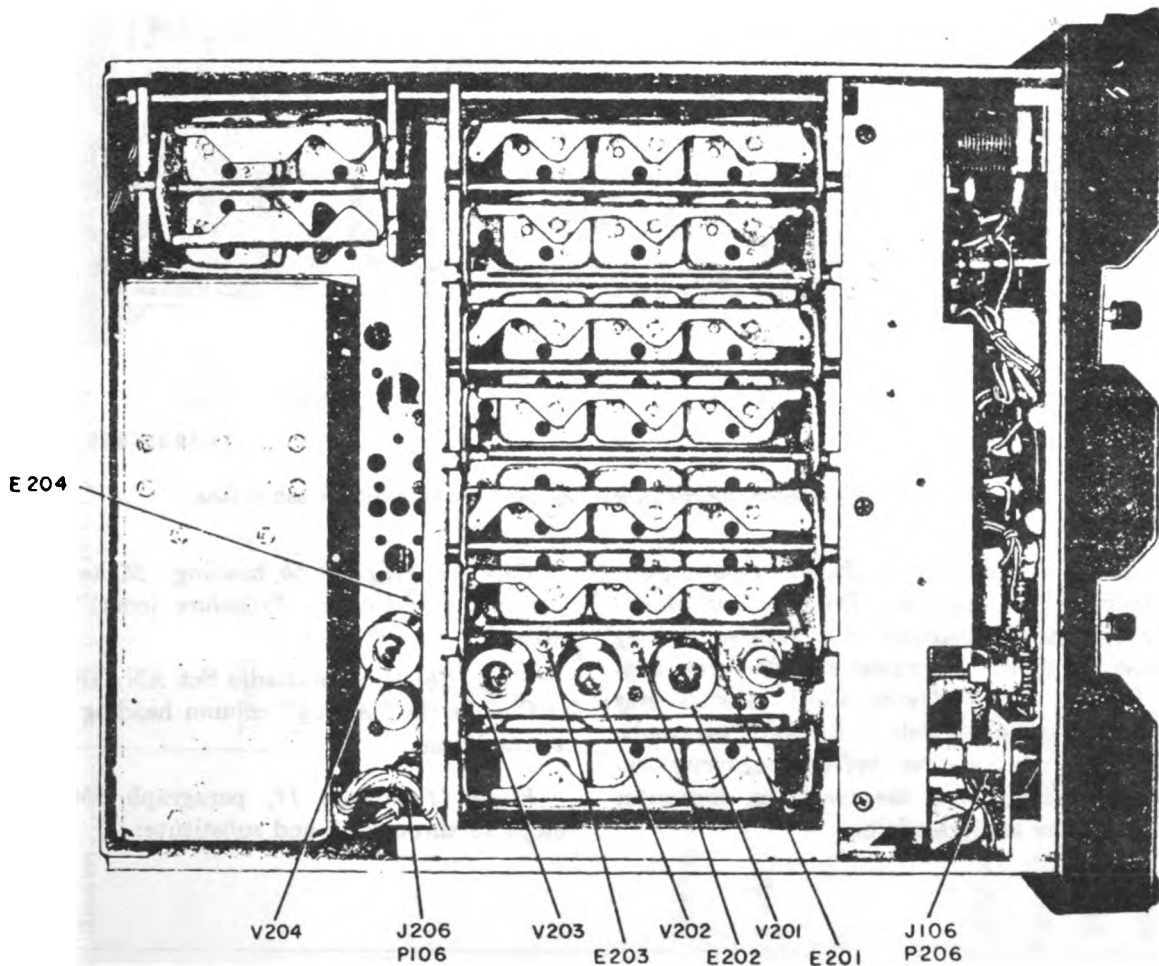

TM5820-295-20-C1-1

Figure 7. (Superneded) Receiver tube, plug, and test point locations, top view.

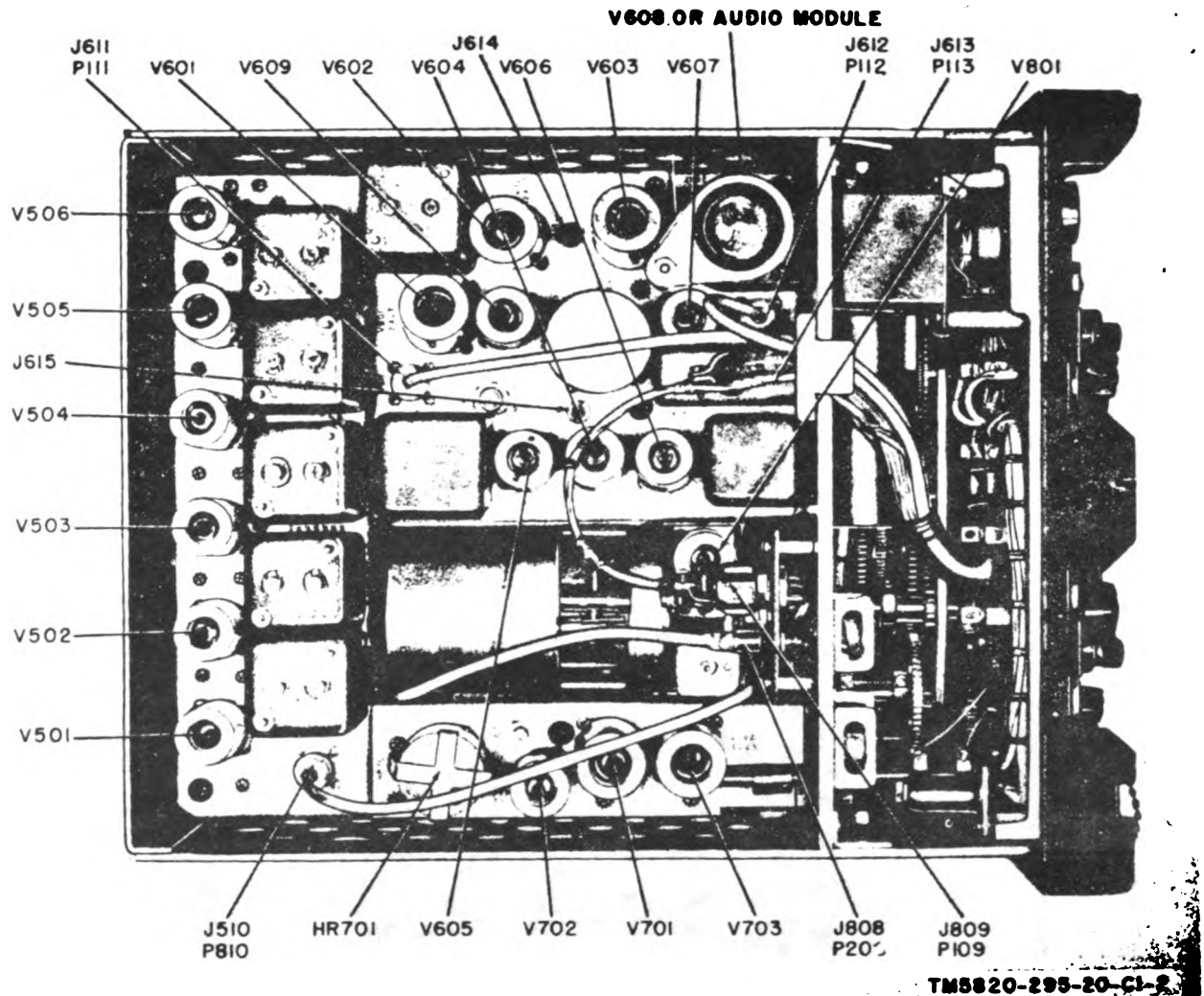

Figure 8. (Superseded) Receiver tube, plug, and test point locations, bottom view.

2. A transistorized audio module is used in place of V608 in some receivers. Do not short circuit module terminals to ground in a receiver having an audio module. Transistors are very sensitive to improper voltages; short circuits may damage the audio module. Remove the audio module from the receiver before measuring resistances in the receiver; the use of an ohmmeter may damage the audio module.

Page 10, paragraph 5b, heading. Make the following changes: Delete "Procedure (cont)" and substitute:

(1) Checklist for Radio Set AN/GRC-19.

Change the "Action" column heading to: Action or condition.

Pages 11 through 17, paragraph 5b(1), delete steps 15 through 68 and substitute:

EQUIPMENT PERFORMANCE

Step	Unit	Action or condition	Normal indication	Corrective measure
15	Receiver	<p>Set the function switch to <b>NORMAL</b>.</p> <p>Turn the <b>AF GAIN</b> fully clockwise.</p> <p>If a signal or rushing noise is heard, omit steps 16 through 23 and continue with step 24.</p> <p>If the <b>CARRIER LEVEL</b> meter indicates normal when <b>MEGACYCLES</b> and <b>KILOCYCLES</b> controls are turned to receive a signal, but no signal is heard in the headset the trouble is isolated to steps 16 through 19.</p> <p>If meter reading is normal and audio signal is normal when <b>MEGACYCLES</b> and <b>KILOCYCLES</b> controls are adjusted to receive a signal, omit steps 16 through 30 and continue with step 31.</p>	<p>Dial lamps light.</p> <p><b>CARRIER LEVEL</b> meter gives a maximum indication momentarily.</p> <p>A signal or rushing noise is heard in the headset, and the <b>CARRIER LEVEL</b> meter shows the strength of the received signal or noise.</p> <p><i>Note.</i> Tune the receiver to receive a strong signal. The <b>CARRIER LEVEL</b> meter will not indicate on weak signals.</p>	<p>Check dial lamps.</p> <p>Check <b>DIAL DIM</b> switch.</p> <p>Check Fuse <b>F102</b>.</p> <p>Check for proper seating of <b>P206</b> in <b>J106</b> (fig. 7).</p> <p>Check Fuse <b>F101</b>.</p> <p>Check for proper seating of <b>P113</b> in <b>J613</b> (fig. 8).</p> <p>Check the headset.</p> <p>Check the <b>RF</b> cable connections and the antenna connections.</p>
16	Receiver	<p>Touch ohmmeter leads (<b>Rx1</b> range) between test jack <b>J615</b> (fig. 8) and chassis. Repeat if necessary.</p>	<p>A clicking sound is heard in the headset.</p>	<p>Check <b>V603</b>, <b>V606</b>, <b>V607</b>, and <b>V608</b> or the transistorized audio module (fig. 8) by substitution.</p>
17	Receiver	<p>Remove <b>P810</b> from <b>J510</b> (fig. 8) and touch the ohmmeter leads between the center conductor of <b>J510</b> and chassis; momentarily reverse the meter leads and again touch the center conductor of <b>J510</b>. Repeat if necessary.</p> <p>Reconnect <b>P810</b> and <b>J510</b> after this step has been completed.</p>	<p>A clicking sound is heard in the headset. . . . .                      If a clicking sound is heard in the headset . . . . . omit steps 18 through 23 and continue with step 24.</p>	<p>Check <b>V501</b> through <b>V506</b> (fig. 8) by substitution.</p>
18	Receiver	<p>Remove and replace <b>V506</b> (fig. 8) rapidly.</p>	<p>A clicking sound is heard in the headset. . . . .</p>	<p>Check tube <b>V506</b> (fig. 8) by substitution.</p>
19	Receiver	<p>Remove and replace <b>V505</b> (fig. 8) rapidly.</p>	<p>A clicking sound is heard in the headset. . . . .</p>	<p>Check tube <b>V505</b> (fig. 8) by substitution.</p>
20	Receiver	<p>Remove and replace <b>V504</b> (fig. 8) rapidly.</p>	<p>A clicking sound is heard in the headset. . . . .</p>	<p>Check tube <b>V504</b> (fig. 8) by substitution.</p>
21	Receiver	<p>Remove and replace <b>V503</b> (fig. 8) rapidly.</p>	<p>A clicking sound is heard in the headset. . . . .</p>	<p>Check tube <b>V503</b> (fig. 8) by substitution.</p>
22	Receiver	<p>Remove and replace <b>V502</b> (fig. 8) rapidly.</p>	<p>A clicking sound is heard in the headset. . . . .</p>	<p>Check tube <b>V502</b> (fig. 8) by substitution.</p>



## EQUIPMENT PERFORMANCE

Step	Unit	Action or condition	Normal indication	Corrective measure
23	Receiver.....	Remove and replace V501 (fig. 8) spidly. Repeat if necessary.	A clicking sound is heard in the headset.....	Check tube V501 (fig. 8) by substitution.
24	Receiver.....	Remove P208 from J808 (fig. 8) and touch ohmmeter leads between center conductor of J808 and chassis. Repeat if necessary. Reconnect P208 and J808 after this step has been completed.	A clicking sound is heard in the headset.....	Check tube V801 by substitution. Check for proper seating of P109 in J809 (fig. 8).
25	Receiver.....	Touch ohmmeter leads between test point E204 (fig. 7) and chassis.	A clicking sound is heard in the headset.....	Check tube V204 (fig. 7) by substitution.
26	Receiver.....	Touch ohmmeter leads between test point E203 and chassis (fig. 7). <i>Note.</i> The receiver must be set to a frequency below 8 mc for this test.	A clicking sound is heard in the headset.....	Check tubes V203 and V402 (figs. 7 and 9) by substitution.
27	Receiver.....	Touch ohmmeter leads between test points E202 and chassis (fig. 7).	A clicking sound is heard in the headset.....	Check tube V202 (fig. 7) by substitution.
28	Receiver.....	Touch ohmmeter leads between test point E201 and chassis (fig. 7).	A clicking sound is heard in the headset.....	Check tube V201 (fig. 7) by substitution.
29	Receiver.....	Touch ohmmeter leads between ANT. terminal and chassis.	A clicking sound is heard in the headset.....	Check for proper seating of P206 in J106 (fig. 7).
30	Receiver.....	Adjust the KILOCYCLES and MEGACYCLES controls to receive a strong signal.	A strong, clear signal is heard in the headset and the CARRIER LEVEL meter shows signal strength.	Check tubes V609 and V602 (fig. 8) by substitution.
31	Receiver.....	Set the BFO switch at ON. Adjust the MEGACYCLES and KILOCYCLES control until a cw signal is heard in the headset.	Sharp, clear cw signals are heard in the headset.	Check tube V604 (fig. 8) by substitution. Check for proper seating of P112 in J612 (fig. 8).
32	Receiver.....	Turn the BFO PITCH control through its entire range.	The tone of the cw signal changes.....	Higher echelon repair required.
33	Receiver.....	Set the AGC switch at CAL..... Turn the KILOCYCLES control through its entire range.	A beat note is heard in the headset, and the CARRIER LEVEL meter pointer moves at every 100-kc-point on the frequency indicator below 20 mc.	Check V701, V702, and V703 (fig. 8) by substitution. If calibration checkpoints are heard at 200-kc multiples only, check V701. If calibration is not possible on higher frequencies, check V703. If calibration is unstable and off frequency, check V702.
34	Receiver.....	Set the function switch at SQ..... Turn the RF GAIN control to the left (counterclockwise) so that the signal heard in the headset disappears. Rotate the control clockwise until the signal is barely heard. Turn the KILOCYCLES control through its entire range.	Minimum noise is heard as the receiver is tuned between stations (or when listening to AM signals) and the receiver is quiet between transmissions.	Check V602 and V605 (fig. 8) by substitution.

EQUIPMENT PERFORMANCE

35	Transmitter.....	Set the SERVICE SELECTOR switch at CALIB. (Allow the equipment to warm up for 5 minutes.)	Test meter indicates normal battery voltage and the dial lamps light.	If there is no indication, check front-panel fuse 15 AMP., 24 VOLT, power cable connections, and dial lamps. If the fuse keeps burning out, the transmitter is probably defective. Refer to TM 11-806.
36	Transmitter.....	Set the TEST METER switch at PA GRID.	Movement of air is felt at the air vents..... LV dynamotor or LV transistor-type power supply starts after 40 seconds $\pm$ 10 seconds.	Check for proper seating of P1101 in J610 and P1101 in J612 (fig. 4). Make sure that the interlock switch is closed by tightening the 16 Allen-head screws.
37	Transmitter.....	Set the PRESET CHANNELS switch at M. Unlock the locking bar on the BAND SELECTOR switch. Unlock the locking bar on the TUNING CONTROL. Turn the BAND SELECTOR switch to each of the 10 bands in turn, and, while on each band, turn the TUNING CONTROL to the low and high ends of each band.	Test meter indicates within shaded area marked PA GRID.	Check for proper seating of P401 in J606 (fig. 5). Check dynamotor or LV transistor-type power supply fuse F602 (10 amp). Check for proper seating of P801 in J101 (fig. 4), P101 in J607, P802 in J617, and P201 in J608 (figs. 4 and 5). If the test meter reading is low, check by substitution: V801, V802, V101, V102, V103, V104, V601 and V201 (figs. 4 and 5).
38	Transmitter.....	Set the SERVICE SELECTOR switch at CW.	Test meter indicates within the shaded area marked PA GRID.	Check V101, V102, and V103 (fig. 4) by substitution.
39	Transmitter.....	Set the TEST METER switch at PA CATH.	The HV dynamotor or transistor-type power supply starts within 10 seconds.	Check high voltage fuse F603.
40	Transmitter.....	Hold the TEST KEY at ON.....	TUNING INDICATOR lights, goes out, lights again, and remains lighted after a slight delay of not more than 30 seconds. <i>Note.</i> If the transmitter has been manually tuned from one frequency to another in the same band, or manually tuned to the same frequency in another band, the TUNING INDICATOR may not light or may light and remain lighted. In this case, switch the BAND SELECTOR switch to an adjacent band and back again, and wait for the tuning cycle to be completed.	Check tube V202 by substitution (fig. 6). Check the TUNING INDICATOR lamp. Check the antenna and ground connections. Check for proper seating of: P101 in J607, P302 in J609 (fig. 4), P901 in J611, P201 in J608, P205 in J618-A, and P206 in J618-B (fig. 5). Check by substitution: V201, V202, V203, V204, V901, V902, V903, and V904 (figs. 5 and 6).

EQUIPMENT PERFORMANCE

Step	Unit	Action or condition	Normal indication	Corrective measure
41	Transmitter.....	Turn the BAND SELECTOR switch to each one of the 10 bands in turn, and, while on each band, turn the TUNING CONTROL to the low and high end of each band. Hold the transmitter TEST KEY at the ON position after each frequency setting. (Wait until each tuning cycle is finished for each frequency setting before proceeding to the next one.) Release the TEST KEY.....	After the tuning cycle is finished the test meter indicates within the shaded area marked PA CATHODE. The TUNING INDICATOR will stay lighted and the 400-cycle sidetone is heard in the headset. <i>Note.</i> Refer to the note in step 40.	If Antenna Coupler AN/GRA-12 is being used, change the length of the antenna slightly. Same as for step 40.
42	Transmitter.....	Release the TEST KEY.....	The TUNING INDICATOR is not lighted. The test meter reads zero. The 400-cycle sidetone is not heard in the headset.	
43	Telegraph key....	Hold the telegraph key closed.....	The test meter indicates within the shaded area marked PA CATHODE. The TUNING INDICATOR stays lighted. <i>Note.</i> Refer to the note in step 40 above. The 400-cycle sidetone is heard in the headset.	Check the telegraph key and the telegraph key cable.
44	Telegraph key....	Release the telegraph key.		
45	Transmitter.....	Set the SERVICE SELECTOR switch at STANDBY.	The dynamotor or transistor-type power supplies stop. The test meter reads zero. The TUNING INDICATOR is not lighted. No sound is heard in the headset. The dynamotors or transistor-type power supplies do not start. The TUNING INDICATOR is not lighted. The test meter reads zero.	
46	Transmitter.....	Set SERVICE SELECTOR switch at VOICE/FSK.	The dynamotors or transistor-type power supplies start. The TUNING INDICATOR stays lighted. <i>Note.</i> Refer to the note in step 40.	
47	Microphone.....	Press the microphone switch.....  Talk into the microphone..... Speak normally and hold the microphone about 2 inches from the lips.	The test meter indicates in the shaded area marked PA CATHODE, and the pointer moves slightly while the operator is talking. The audio level meter reads up to 100 on the peaks. The voice sidetone signal is heard in the headset.	Check for proper seating of P401 in J606 (fig. 5).  Check by substitution: V401, V402, V403, V404, V406, and V407 (fig. 5).  Check the microphone and the microphone cord.



EQUIPMENT PERFORMANCE	
48	<p>Transmitter.....</p> <p>Lock the locking bar on the BAND SELECTOR switch. Lock the locking bar on the TUNING CONTROL. Press the reminder spring on the PRESET CHANNELS switch. Turn the switch from the M position to each of the positions which have channels preset. At each position, check for accuracy of the reading on the frequency indicator. Wait until the drive motor stops before turning the PRESET CHANNELS switch to a new channel.) Set the DIAL DIM switch at OFF..... Set the DIAL DIM switch at DIM..... Set the DIAL DIM switch at ON.....</p>
49	<p>Transmitter.....</p>
50	<p>Transmitter.....</p>
51	<p>Transmitter.....</p>
52	<p>Transmitter.....</p>
53	<p>Receiver.....</p>

If the frequency indicator shows a frequency that differs by more than 20 kc from the frequency assigned to the channel, or if there is any doubt as to the true output frequency, recalibrate the channel. Refer to TM 11-806.

As the switch is set at each channel, the BAND SELECTOR switch and the TUNING CONTROL will turn. This will tune the transmitter to a frequency that is shown on the frequency indicator. Within limits, the reading on the frequency indicator will agree with the frequency written on the chart for each channel.

The dial lamps are not lighted.  
The dial lamps light dimly.....  
The dial lamps light fully.....

Replace the lamps that do not light.  
Replace the lamps that do not light.

Higher echelon repair required.  
Higher echelon repair required.

The transmitter is shut off.....  
The receiver is shut off.....

STOP

Page 17, paragraph 5b, second chart. Add at top of chart:

(2) Checklist for Control C-822/GRC-19.

Paragraph 6a, add the following caution after line 6:

**Caution:** A transistorized audio module is used in place of V608 in some receivers. Do not place the audio module in a tube tester; check it only by substitution.

Page 19, paragraph 6, subparagraph c chart, "Type" column, line 1. Change 26A6 to: 26A6 or 26FZ6.

Line 2. Change 26A6 to: 26A6 or 26FZ6.

Line 20. Change 26A7 to: 26A7 or transistorized audio module.

Subparagraph d, line 4. Delete "following table" and substitute: table above.

Page 20, paragraph 6f, line 4. Delete "following table" and substitute: table above.

BY ORDER OF THE SECRETARIES OF THE ARMY AND THE AIR FORCE:

G. H. DECKER,  
General, United States Army,  
Chief of Staff.

Official:

R. V. LEE,  
Major General, United States Army,  
The Adjutant General.

Official:

R. J. PUGH,  
Colonel, United States Air Force,  
Director of Administrative Services.

THOMAS D. WHITE,  
Chief of Staff, United States Air Force.

Distribution:

Active Army:

To be distributed in accordance with DA Form 12-7 requirements for TM 11-series (unclas); plus the following:

USASA (2)	5-37	6-200
CNGB (1)	5-54	6-201
Tech Stf, DA (1) except CSigO (18)	5-77	6-300
DASA (5)	5-78	6-311
ARADCOM (2)	5-115	6-315
ARADCOM Rgn (2)	5-116	6-316
MDW (1)	5-117	6-101
Seventh USA (2)	5-118	6-317
EUSA (2)	5-129	6-319
USASCS (39)	5-167	6-325
Units org under fol TOE's:	5-192	6-326
(2 each UNOINDC)	5-225	6-327
1-7	5-226	6-330
1-17	5-237	6-401
1-25	5-278	6-501
1-26	5-355	6-525
1-37	5-356	6-545
1-57	5-357	6-565
1-67	5-358	6-575
1-107	5-359	6-576
5-5	5-372	6-577
5-6	5-376	7
5-7	5-377	7-11
5-8	6-37	7-12
5-15	6-100	7-25
5-16	6-125	7-26
5-17	6-126	8-15
5-35	6-135	8-16
	6-136	8-61

TAGO 6377-A

8-75	11-592	44-16
8-76	11-597	44-35
8-77	17	44-36
8-78	17-2	44-37
9-47	17-22	44-101
9-76	17-25	44-235
9-87	17-26	44-236
9-217	17-45	44-435
9-227	17-46	44-436
9-337	17-51	44-437
9-500 AA-AC	17-52	44-445
11-5	17-55	44-446
11-6	17-56	44-447
11-7	17-57	44-448
11-15	17-62	44-535
11-16	17-65	44-536
11-38	17-66	44-537
11-55	17-85	44-544
11-57	17-86	44-545
11-95	29-56	44-546
11-96	32-51	44-547
11-97	32-56	44-548
11-98	32-57	55-11
11-117	32-67	55-12
11-155	39-51	55-38
11-165	39-61	55-157
11-237	39-65	55-457
11-500 AA-AE, RA-RT (4)	44-2	55-500 AA-AE
11-555	44-12	57
11-557	44-15	57-5
11-587		

**NG:** State AG (3); units—same as Active Army except allowance is one copy to each unit.

**USAR:** None.

For explanation of abbreviations used, see AR 320-50

823-239





## Organizational Maintenance

### RADIO SET AN/GRC-19

TM 11-5820-295-20 }  
TO 31R2-2GRC19-32 }  
CHANGES No. 3 }

DEPARTMENTS OF THE ARMY  
AND THE AIR FORCE  
WASHINGTON 25, D.C., 14 May 1963

TM 11-5820-295-20/TO 31R2-2GRC19-32, 3 June 1960, is changed as follows:

*Page 2.* Chapter 1. Make the following changes:

Change the heading to: INTRODUCTION

Delete section I and substitute new Section I. GENERAL.

#### 1. Scope

This manual covers the installation and organizational maintenance instructions for Radio Set AN/GRC-19. Operating instructions and operational maintenance are contained in TM 11-5820-295-10.

#### 2. Index of Publications

Refer to the latest issue of DA Pam 310-4, to determine whether there are any new editions, changes, or additional publications pertaining to this equipment. DA Pam 310-4 is an index of current technical manuals, technical bulletins, supply bulletins, lubrication orders, and modification work orders that are available through publications supply channels. The index lists the individual parts (-10, -20, -35P

etc.) and the latest changes to and revisions to each equipment publication.

#### 3. Forms and Records

*a. Reports of Maintenance and Unsatisfactory Equipment.* Use equipment forms and records in accordance with instructions in TM 38-750.

*b. Report of Damaged or Improper Shipment.* Fill out and forward DD Form 6 (Report of Damaged or Improper Shipment) as prescribed in AR 700-58 (Army), NAVSANDA Publication 378 (Navy), and AFR 71-4 (Air Force).

*c. Comments on Manual.* Forward all comments on this publication direct to: Commanding Officer, U.S. Army Electronics Materiel Support Agency, ATTN: SELMS-MP, Fort Monmouth N.J. (DA Form 1598 (Record of Comments on Publications), DA Form 2496 (Disposition Form), or letter may be used.)

*Page 5,* paragraph 4. Delete subparagraph *k.*

*Page 22.* Add chapters 1.1 and 1.2 after chapter 1.

## CHAPTER 1.1

### INSTALLATION

#### 8.1. Unpacking

*a. Packaging Data.* When packed for shipment, the T-195(\*)/GRC-19, R-392/URR, Bag CW-206/GR, and miscellaneous items are

placed in cartons and packed in wooden boxes. Mounting MT-851/GRC-19 is packed in a wooden box without being placed in a carton. A typical shipping box and its contents are shown in figure 10.1.

Box No.	Height (in.)	Width (in.)	Depth (in.)	Volume (cu ft)	Unit weight (lb)	Contents of box
1	14½	30¾	18½	4.6	166	Transmitter, Radio T-195 (*)/GRC-19.
2	14½	20¾	18¾	3.0	81	Receiver, Radio R-392/URR.
3	8½	43½	11	2.4	37	Bag CW-206/GR and miscellaneous items.
4	17	37¾	5¾	1.9	70	Mounting MT-851/GRC-19.

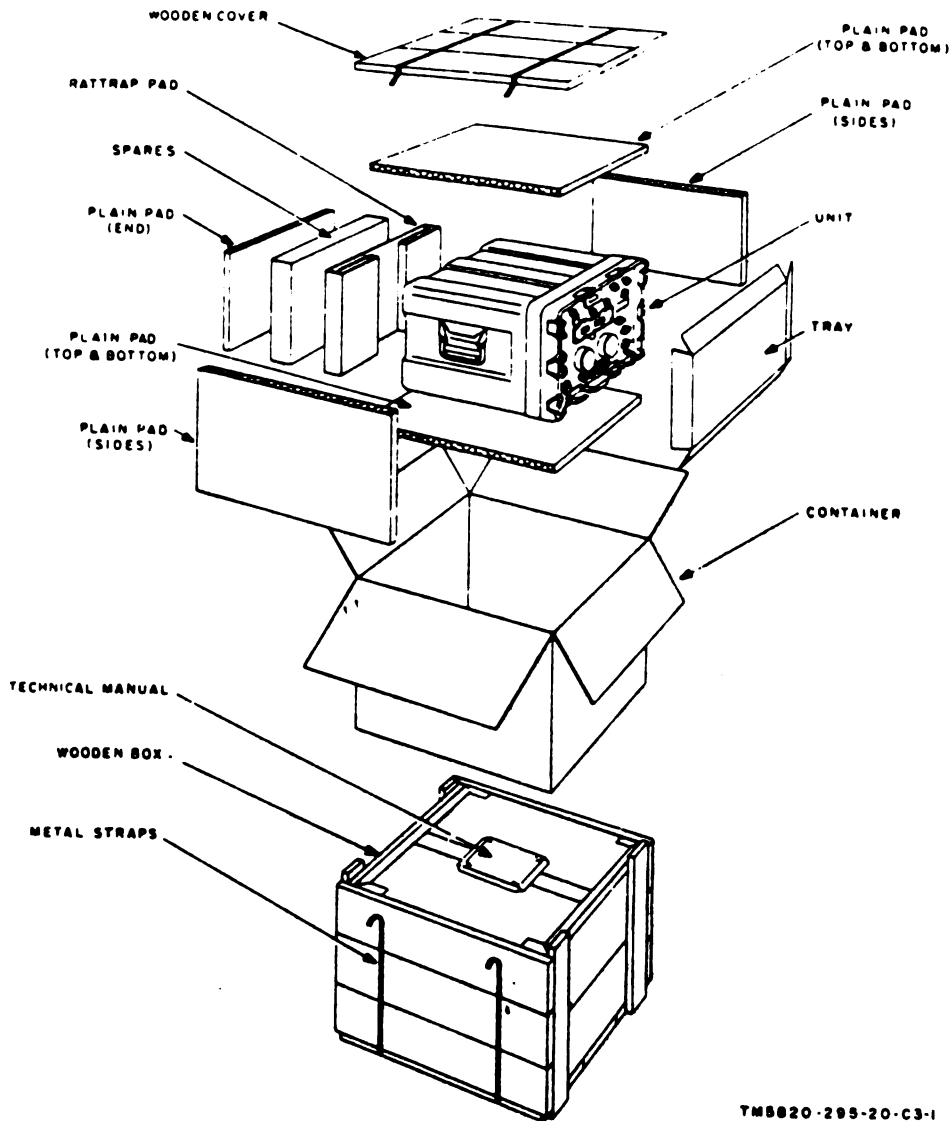

TMB820-295-20-C3-1

Figure 10.1. Typical packaging.

*b. Removing Contents.* Perform all of the procedures outlined below when unpacking the T-195 (\*)/GRC-19, R-392/URR, and Bag CW-206/GR. When unpacking Mounting MT-851/GRC-19, omit procedures (3) and (4) below.

- (1) Cut and fold back the metal straps.
- (2) Remove the nails from the top and one side of the box with a nailpuller. Remove the top and one side.



**Caution:** Do not attempt to pry the box open, or the equipment may be damaged.

- (3) Remove the carton.
- (4) Open the carton.
- (5) Remove the contents.

## 8.2. Checking Unpacked Equipment

a. Inspect the equipment for damage incurred during shipment. If the equipment is damaged, refer to paragraph 3.

b. See that the equipment is complete as listed on the packing slip. If the packing slip is not available, check the equipment received against the basic issue items list (app. II, TM 11-5820-295-10).

## 8.3. Internal Connections

a. The T-195(\*)/GRC-19 must be properly connected for voice and cw operation. When receiving a new or reconditioned T-195(\*)/GRC-19, make the following check to insure proper connection.

- (1) Set Multimeter AN/URM-105 on OHMS.
- (2) Place the multimeter test leads on the center conductors of the FSK IN and MO OUT connectors, located on the front panel.
- (3) An indication of 0 ohm on the ohmmeter indicates proper connection for voice and cw operation.

b. If the ohmmeter indicates infinite resistance proceed as follows:

- (1) Loosen the 16 Allen-head screws that hold the front panel to the cabinet, and slide the transmitter out of its case.
- (2) Remove plug P601 from jack J101 (fig. 4). Remove plug P801 from jack J620.
- (3) Insert plug P801 into jack J101. Insert plug P101 into jack J620.
- (4) Push the transmitter back into its case, and tighten the 16 front panel Allen-head screws.

# CHAPTER 1.2

## MAINTENANCE INSTRUCTIONS

### 8.4. Scope of Organizational Maintenance

Organizational maintenance of Radio Set AN/GRC-19 consists of the following:

- a. Preventive maintenance checks and services (par. 8.7).
- b. Visual inspection (par. 4).
- c. Equipment performance checklist (par. 5).
- d. Tube testing and replacement (par. 6).
- e. Checking transistorized audio module (in some receivers) by substitution.
- f. Removal and replacement of dial lamps (par. 7).
- g. Removal and replacement of fuses (par. 8).

### 8.5. Preventive Maintenance

a. Preventive maintenance is the systematic care, inspection, and servicing of the equipment to maintain it in serviceable condition, prevent breakdowns, and insure maximum operational

capability. Preventive maintenance is the responsibility of all echelons concerned with the equipment, and includes the inspection, testing, and repair or replacement of parts, subassemblies, or units that checks and services indicate would probably fail before the next scheduled periodic service. Preventive maintenance checks and services of the radio set at the second echelon level are made at quarterly intervals unless otherwise directed by the commanding officer.

b. Maintenance forms and records to be used on this equipment are specified in TM 38-750.

c. Clean rust and corrosion from metal surfaces by lightly sanding them with fine sandpaper. Brush two thin coats of the proper paint on bare metal to protect it from further corrosion. Refer to the applicable cleaning and refinishing practices specified in TM 9-213.

### 8.6. Quarterly Maintenance

Quarterly maintenance of Radio Set AN/GRC-19 will be scheduled in accordance with the requirements of TM 38-750. If the equipment is part of a vehicular installation, the quarterly maintenance should be scheduled concurrently with the periodic service schedule of the carrying vehicle to reduce out-of-service time to a minimum. All deficiencies or shortcomings will be recorded and those not corrected during the checks and service will be immediately reported to higher echelon by use of forms and procedures specified in TM 38-750. Equipment that has a deficiency that

cannot be corrected by second echelon should be deadlined in accordance with TM 38-750. Perform all the preventive maintenance checks and services listed in the quarterly preventive maintenance checks and services chart (par. 8.7) in the sequence listed. To assist second echelon personnel in maintaining combat serviceability, the charts indicate what to check, how to check, and what the normal conditions are; the *References* column lists the illustrations, paragraphs, or manuals that contain detailed repair or replacement procedures. Records and reports of these checks and services must be made in accordance with TM 38-150.

### 8.7. Quarterly Preventive Maintenance Checks and Services Chart

Sequence No.	Item	Procedures	References
1	Components: a. Inventory -----  b. Publications -----	a. Inventory equipment; requisition missing and defective parts.  b. Requisition all operator and organizational maintenance manuals and all parts manuals covering Radio Set AN/GRC-19 and its components, that are not on hand or in usable condition (including all current Changes publications).	a. App. II; TM 11-5820-295-10; TM 11-5820-295-20P b. DA Pam 310-4.
2	Modification work orders...	Check to see whether any MWO's are required for Radio Set AN/GRC-19 or its components. Check to see if applicable MWO's have been applied and MWO number is stamped as required. Perform modification or request modification as applicable.	See applicable MWO; see DA Pam 310-4 for MWO's listing; TM 38-750.
3	Exterior surfaces -----	Clean rust and corrosion from metal surfaces. Paint any bare metal spots.	Par. 8.5.
4	Accessible pluckout items...	Check seating of tubes, lamps, fuses, crystals, connectors, and choppers. Firmly seat if necessary.	Figs. 4, 5, 7, and 8.
5	Interior cleaning-----	Remove dirt and dust from the interior of the radio set with a clean lint-free cloth or soft brush. Use dry compressed air (if available) to remove dust and dirt from inaccessible places.	None.
6	Cables, cords, and wires...	Repair insulation cuts and abrasions with electrical insulation tape.	None.
7	Mounting MT-851/GRC-19	Check to see that the equipment mounting and clamps are not so bent, broken, or out of shape as to endanger equipment or personnel.	Fig. 2, TM 11-5820-295-10.
8	Equipment performance---	Check the operation of the AN/GRC-19---	Par. 5.

Page 27, appendix I. Add the following:  
TM 38-750 The Army Equipment Record System and Procedures.

TM 9-213

Painting Instructions for Field Use.

By Order of the Secretaries of the Army and the Air Force:

**EARLE G. WHEELER,**  
*General, United States Army,*  
*Chief of Staff.*

**Official:**

**J. C. LAMBERT,**  
*Major General, United States Army,*  
*The Adjutant General.*

**CURTIS E. LEMAY,**  
*Chief of Staff, United States Air Force.*

**Official:**

**R. J. PUGH,**  
*Colonel, United States Air Force,*  
*Director of Administrative Services.*

**Distribution:**

**Active Army:**

DASA (6)  
USASA (2)  
CNGB (1)  
CofEngrs (1)  
TSG (1)  
CSigO (5)  
CofT (1)  
USA CD Agcy (1)  
USCONARC (5)  
USAMC (5)  
ARADCOM (2)  
ARADCOM Rgn (2)  
OS Maj Comd (3)  
OS Base Comd (2)  
LOGCOMD (2)  
USAECOM (5)  
USAMICOM (3)  
USASCC (4)  
MDW (1)  
Armies (2)  
Corps (2)  
USA Corps (3)  
USATC AD (2)  
USATC Engr (2)  
USATC Inf (2)  
USATC Armor (2)  
Instls (2) except  
    Ft Monmouth (63)  
Svc College (2)  
Br Svc Sch (2)  
GENDEP (OS) (2)  
Sig Dep (OS) (12)  
Sig Sec, GENDEP (5)  
Army Dep (2) except  
    Ft Worth (8)  
    Lexington (12)  
    Sacramento (28)  
    Tobyhanna (12)  
USA Elet RD Actv, White Sands (13)  
USA Elet RD Actv, Ft Huachuca (2)  
USA Trans Tml Comd (1)

Army Tml (1)  
POE (1)  
USAOSA (1)  
AMS (1)  
WRAMC (1)  
AFIP (1)  
Army Pic Cen (2)  
USA Mbl Spt Cen (1)  
USA Elet Mat Agcy (25)  
Chicago Proc Dist (1)  
USARCARIB Sig Agcy (1)  
Sig Fld Maint Shop (3)  
JBUSMC (2)  
1st GM Bde (5)  
SIPRE (5)  
USA Polar R&D Cen (5)  
Madigan Gen Hosp (5)  
USMA (5)  
Mil Msn, Ecuador (5)  
USA Trans Tng Comd (5)  
Arlington Hall Sta (5)  
Units org under fol TOE: (2 each)  
1-7  
1-17  
1-25  
1-26  
1-37  
1-57  
1-67  
1-107  
1-127  
1-137  
5-5  
5-6  
5-7  
5-8  
5-15  
5-16  
5-17  
5-25  
5-26

5-27  
5-35  
5-36  
5-37  
5-45  
5-46  
5-47  
5-49  
5-52  
5-54  
5-77  
5-78  
5-112  
5-115  
5-116  
5-117  
5-118  
5-129  
5-145  
5-146  
5-147  
5-148  
5-155  
5-156  
5-157  
5-167  
5-225  
5-226  
5-237  
5-278  
5-376  
6-37  
6-100  
6-101  
6-125  
6-126  
6-135  
6-136  
6-200  
6-201  
6-225  
6-226  
6-300  
6-301  
6-302  
6-315  
6-316  
6-317  
6-319  
6-325  
6-326  
6-327  
6-330  
6-401  
6-501  
6-525  
6-545  
6-565  
6-575  
6-576  
6-577  
7  
7-11

7-12  
7-15  
7-16  
7-25  
7-26  
7-45  
7-46  
7-100  
8-15  
8-16  
8-35  
8-36  
8-61  
8-75  
8-76  
8-77  
8-78  
9  
9-9  
9-12  
9-47  
9-76  
9-87  
9-217  
9-227  
9-377  
9-500 AA-AC  
10-201  
11-5  
11-6  
11-7  
11-15  
11-16  
11-37  
11-38  
11-39  
11-55  
11-57  
11-95  
11-96  
11-97  
11-98  
11-117  
11-155  
11-157  
11-165  
11-167  
11-237  
11-500 AA-AC, RM-RU  
11-555  
11-557  
11-587  
11-592  
11-597  
17  
17-22  
17-25  
17-26  
17-35  
17-36  
17-42  
17-45  
17-46

17-51	44-86
17-52	44-87
17-55	44-235
17-56	44-236
17-57	44-435
17-65	44-436
17-66	44-437
17-85	44-445
17-86	44-446
17-100	44-447
17-105	44-448
17-106	44-535
17-107	44-536
17-408	44-537
29-1	44-544
29-7	44-545
29-21	44-546
29-56	44-547
32-56	44-548
32-57	55-11
32-67	55-12
37	55-37
37-42	55-36
37-100	55-157
39-51	55-457
39-52	55-468
39-65	55-469
44-2	55-500 AA-AE
44-12	57
44-15	57-5
44-16	57-42
44-85	57-100

**NG:** State AG (3); units—same as active Army except allowance is one copy to each unit.

**USAR:** None.

For explanation of abbreviations used, see AR 320-50.





**TECHNICAL MANUAL**  
**Organizational Maintenance**  
**RADIO SET AN/GRC-19**

TM 11-5820-295-20

CHANGES No. 4

HEADQUARTERS,  
DEPARTMENT OF THE ARMY  
WASHINGTON, D.C., 27 August 1963

TM 11-5820-295-20/TO 31R2-2GRC19-32, 3 June 1960, is changed as follows:

Page 27, appendix I, (as changed by C 2, 15 January 1962 and C 3, 14 May 1963). Delete the following:

- |                    |   |
|--------------------|---|
| TM 11-5820-295-10P | Operation Maintenance Repair Parts and Special Tools List; Radio Set AN/GRC-19.   |
| TM 11-5820-295-20P | Organization, Maintenance Repair Parts and Special Tools List and Maintenance Allocation Chart for Radio Set AN/GRC-19.     |
| TM 11-5820-334-10P | Operator's Maintenance Repair Parts and Special Tools List: Receiver, Radio R-392/URR.                                      |
| TM 11-5820-334-20P | Organizational Maintenance Repair Parts and Special Tools List and Maintenance Allocation Chart: Receiver, Radio R-392/URR. |
| TM 11-5965-231-12P | Handset, Electrical H-113/U.  |

Designate the first sentence as paragraph 1. Add paragraph 2.

2. Additional instructions concerning maintenance of this equipment are contained in:

- |                    |  |
|--------------------|--|
| TM 11-5820-295-20  | Organizational Maintenance Manual: Radio Set AN/GRC-19.  |
| TM 11-5820-334-20  | Organizational Maintenance Manual: Radio Receiver R-392/URR.   |
| TM 11-5820-335-20  | Organizational Maintenance Manual: Radio Transmitters T-195/GRC-19, T-195A/GRC-19, and T-195B/GRC-19.  |
| TM 11-5820-479-12P | Operator and Organizational Maintenance Repair Parts and Special Tools List and Maintenance Allocation Chart: Mast Base MP-65, MP-65A, and MP-65B.       |
| TM 11-5965-231-15P | Operator, Organizational, Field and Depot Maintenance Repair Parts and Special Tool Lists and Maintenance Allocation Chart: Headset, Electrical H-113/U. |
| TM 11-5965-263-12P | Operator and Organizational Maintenance Repair Parts and Special Tools List and Maintenance Allocation Chart: Microphones M-29/U, M-29A/U, and M-29B/U.  |
| DA Pam 310-4       | Index of Technical Manuals, Technical Bulletins, Supply Bulletins, Lubrication Orders, and Modification Work Orders.                                     |

Appendix II, (as added by C 2, 15 January 1962). Delete appendix II and substitute:

\* These changes supersede C 2, 15 January 1962.

**APPENDIX II**  
**MAINTENANCE ALLOCATION**  
**Section I. INTRODUCTION**

**1. General**

a. This appendix assigns maintenance functions to be performed on components, assemblies, and subassemblies by the lowest appropriate maintenance echelon.

b. Columns in the maintenance allocation chart are as follows:

(1) *Part or component.* This column shows only the nomenclature or standard item name. Additional descriptive data are included only where clarification is necessary to identify the component. Components, assemblies, and subassemblies are listed in top-down order. That is, the assemblies which are part of a component are listed immediately below that component, and the subassemblies which are part of an assembly are listed immediately below that assembly. Each generation breakdown (components, assemblies, or subassemblies) is listed in disassembly order or alphabetical order.

(2) *Maintenance function.* This column indicates the various maintenance functions allocated to the echelons.

(a) *Service.* To clean, to preserve, and to replenish lubricants.

(b) *Adjust.* To regulate periodically to prevent malfunction.

(c) *Inspect.* To verify serviceability and to detect incipient electrical or mechanical failure by scrutiny.

(d) *Test.* To verify serviceability and to detect incipient electrical or mechanical failure by use of special equipment such as gages, meters, etc.

(e) *Replace.* To substitute serviceable components, assemblies, or subassemblies, for unserviceable components, assemblies, or subassemblies.

(f) *Repair.* To restore an item to serviceable condition through correction

of a specific failure or unserviceable condition. This function includes but is not limited to welding, grinding, riveting, straightening, and replacement of parts other than the trial and error replacement of running spare type items such as fuses, lamps, or electron tubes.

(g) *Align.* To adjust two or more components of an electrical system so that their functions are properly synchronized.

(h) *Calibrate.* To determine, check, or rectify the graduation of an instrument, weapon, or weapons system, or components of a weapons system.

(i) *Overhaul.* To restore an item to completely serviceable condition as prescribed by serviceability standards developed and published by heads of technical services.

(j) *Rebuild.* To restore an item to a standard as near as possible to original or new condition in appearance, performance, and life expectancy. This is accomplished through the maintenance technique of complete disassembly of the item, inspection of all parts or components, repair or replacement of worn or unserviceable elements using original manufacturing tolerances and/or specifications and subsequent reassembly of the item.

(3) *1st, 2d, 3d, 4th, 5th echelons.* The symbol X indicates the echelon responsible for performing that particular maintenance operation, but does not necessarily indicate that repair parts will be stocked at that level. Echelons higher than the echelon marked by X are authorized to perform the indicated operation.

(4) *Tools required.* This column indicates codes assigned to each individual tool

equipment, test equipment, and maintenance equipment referenced. The grouping of codes in this column of the maintenance allocation chart indicates the tool, test, and maintenance equipment required to perform the maintenance function.

- (6) *Remarks.* Entries in this column will be utilized when necessary to clarify any of the data cited in the preceding column.

c. Columns in the allocation of tools for maintenance functions are as follows:

- (1) *Tools required for maintenance functions.* This column lists tools, test, and

maintenance equipment required to perform the maintenance functions.

- (2) *1st, 2d, 3d, 4th, 5th echelon.* The dagger (†) indicates the echelons normally allocated the facility.

- (3) *Tool code.* This column lists the tool code assigned.

## 2. Maintenance by Using Organizations

When this equipment is used by signal services organizations organic to theater headquarters or communication zones to provide theater communications, those maintenance functions allocated up to and including fourth echelon are authorized to the organization operating this equipment.

SECTION II. MAINTENANCE ALLOCATION CHART

PART OR COMPONENT	MAINTENANCE FUNCTION	EPOCH					TOOLS REQUIRED	REMARKS	
		1	2	3	4	5			
RADIO SET AN/GR-19	Service inspect test	X	X				22, 21	No facilities required at 2nd echelon	
		X	X				20, 21, 11, 6, 15, 16, 12		
	Replace repair align	X	X				20, 21, 3, 4, 12, 11, 7, 13, 25	Shop facilities	
		X	X				20, 21, 11, 6, 15, 16, 12		
	Calibrate overhaul	X	X				20, 11, 6, 15, 16	For 4th echelon: Refer to TM 11-5820-334-20; TM 11-5820-335-20	
		X	X				20, 11, 6, 15, 16		
	test Replace repair	X	X				12	All special tools plus shop facilities	
		X	X				22		
	INSULATOR IN-86	Replace	X	X					Continuity. Refer to TM 11-5965-231-1P
			X	X					
JACK TELEPHONE	Replace	X	X					Connector cap only Refer to TM 11-5820-479-12P	
		X	X						
KEY TELEGRAPH KY-116/U	Replace align	X	X					Refer to TM 11-5965-263-12P Continuity 2ND replace cover	
		X	X						
MAST BASE MP-65	Repair	X	X				22	Refer to TM 11-5820-334-20	
		X	X				20		
MAST SECTION	Replace	X	X				12	Refer to TM 11-5965-263-12P Continuity 2ND replace cover	
		X	X				20		
MICROPHONE M-25/U	Service inspect test	X	X				10, 19, 22	Refer to TM 11-5820-334-20	
		X	X				20		
RECEIVER R-392/U/R	Replace inspect test	X	X				1, 4, 6, 12, 11, 14, 15, 16	Plus shop facilities	
		X	X				1, 3, 4, 7, 12, 11, 16, 25, 26, 23		
	Replace align calibrate overhaul	X	X				1, 3, 4, 7, 12, 11, 16, 18, 25, 26, 23, 8		
		X	X				20, 11, 6, 16, 15, 19		
		X	X				20, 4, 11, 6, 15, 25		
		X	X				25, 20		
		X	X				2C, 21		

NAME OF COMPONENT	MAINTENANCE FUNCTION	EDISON						TOOLS REQUIRED	REMARKS
		1	2	3	4	5	6		
AN/GRC-19 (continued) TRANSMITTER RADIO T-195/GRC-19  ROPE RP-5 ANTENNA SHEATH CLAMP COVER, ANTENNA	service	X	X	X				22 20 20	Refer to TM 11-5820-335-20
		inspect	X	X					
	test	X	X	X				2,3,4,13,17,25,26,19	Distortion, resistance, audio output
	replace	X			X				
	repair	X	X	X	X			20,11,6,15 20,4,11,7,25 20,21	
	align	X	X	X	X				
	overhaul	X							
	replace	X							
	replace	X							
	replace	X							

AN/GRC-19

SECTION III. ALLOCATION OF TOOLS FOR MAINTENANCE FUNCTIONS

TOOLS REQUIRED FOR MAINTENANCE FUNCTIONS	Echelons					TOOL CODE	REMARKS
	1	2	3	4	5		
AN/GRC-19 (continued)							
ACCESSORY KIT KT-288/URM						1	
AMMETER R.F. FSN 6625-668-9189						2	
ANALYZER SPECTRUM TS-723/U						3	Model D only
AUDIO OSCILLATOR TS-382/U						4	
DUMMY LOAD, ELECTRICAL DA-94/GRC-19						5	
FREQUENCY METER AN/URM-32						6	
FREQUENCY METER AN/URM-79						7	
MAINTENANCE KIT, ELECT EQ MK-420/URR						8	
MAINTENANCE KIT, ELECT EQ MK-421/GRC-19						9	
MULTIMETER AN/URM-105						10	
MULTIMETER, METER ME-26/U						11	
MULTIMETER TS-352/U						12	
OSCILLOSCOPE AN/USN-50						13	
OUTPUT METER TS-585/U						14	
POWER SUPPLY PP-1243/U						15	
R.F. SIGNAL GENERATOR AN/URM-25						16	
R.F. WATTMETER TS-118A/AP						17	
TEST SET ELECTRON TUBE TV-2/U						18	
TEST SET ELECTRON TUBE TV-7/U						19	
TOOL KIT TK-87/U						20	
TOOL KIT TK-88/U						21	
TOOL KIT TK-115/U						22	
TOOL KIT, RADIO RECEIVER TK-97/URR						23	
TOOL KIT, RADIO TRANSMITTER TK-98/GRC-19						24	

AN/GRC-19

TOOLS REQUIRED FOR MAINTENANCE FUNCTIONS	EOWELON 1 2 3 4 5 . <th data-bbox="122 1115 201 1318">TOOL CODE</th> <th data-bbox="122 1318 201 1764">REMARKS</th>	TOOL CODE	REMARKS
AN/GRC-19 (continued) VOLTMETER METER ME-30/U WATCH, STOP TYPE PSN 6645-719-8750	↑ ↑ ↑ ↑ ↑	25 26	

AN/GRC-19

By Order of the Secretary of the Army:

**EARLE G. WHEELER,**  
*General, United States Army,*  
*Chief of Staff.*

Official:

**J. C. LAMBERT,**  
*Major General, United States Army,*  
*The Adjutant General.*

Distribution:

*Active Army:*

DASA (6)	WRAMC (1)	5-54 (2)
USASA (2)	MGH (5)	5-77 (2)
CNGB (1)	AFIP (1)	5-78 (2)
CofEngrs (1)	USAPRDC (5)	5-112 (2)
TSG (1)	USATTC (5)	5-115 (2)
CSigO (7)	SIPRE (5)	5-116 (2)
CofT (1)	Mil Man (Ecuador) (5)	5-117 (2)
OCofSptS (1)	Army Pic Cen (2)	5-118 (2)
USA CD Agcy (1)	USA Elct RD Actv	5-129 (2)
USCONARC (5)	(White Sands) (13)	5-145 (2)
USAMC (5)	USA Elct RD Actv	5-146 (2)
USAECOM (5)	(Ft Huachuca) (7)	5-147 (2)
USAMICOM (4)	USA Mbl Spt Cen (1)	5-148 (2)
ARADCOM (2)	USA Elct Mat Agcy (12)	5-155 (2)
ARADCOM Rgn (2)	Chicago Proc Dist (1)	5-156 (2)
OS Maj Comd (3)	USARCARIB Sig Agcy (1)	5-157 (2)
OS Base Comd (2)	Sig Fld Maint Shops (3)	5-167 (2)
LOGCOMD (2)	USA Corps (3)	5-225 (2)
MDW (1)	Units org under fol TOE:	5-226 (2)
Armies (2)	1-7 (2)	5-237 (2)
Corps (2)	1-17 (2)	5-278 (2)
Div (2)	1-25 (2)	5-376 (2)
1st GM Bde (5)	1-26 (2)	6-37 (2)
Instl (2) except	1-37 (2)	6-100 (2)
Ft Monmouth (65)	1-57 (2)	6-101 (2)
USATC AD (2)	1-67 (2)	6-125 (2)
USATC Armor (2)	1-107 (2)	6-126 (2)
USATC Inf (2)	1-127 (2)	6-135 (2)
USATC Engr (2)	1-137 (2)	6-136 (2)
USASTC (5)	5-5 (2)	6-200 (2)
USASCC (4)	5-6 (2)	6-201 (2)
Svc Colleges (2)	5-7 (2)	6-225 (2)
Br Svc Sch (2)	5-8 (2)	6-226 (2)
USMA (5)	5-15 (2)	6-300 (2)
GENDEP (OS) (2)	5-16 (2)	6-301 (2)
Sig Sec, GENDEP (5)	5-17 (2)	6-315 (2)
Sig Dep (OS) (12)	5-25 (2)	6-316 (2)
Army Dep (2) except	5-26 (2)	6-317 (2)
Ft Worth (8)	5-27 (2)	6-319 (2)
Lexington (12)	5-35 (2)	6-325 (2)
Sacramento (23)	5-35 (2)	6-325 (2)
Tobyhanna (12)	5-37 (2)	6-327 (2)
USA Tml Comd (1)	5-45 (2)	6-330 (2)
Army Tml (1)	5-46 (2)	6-401 (2)
POE (1)	5-47 (2)	6-501 (2)
USAOSA (1)	5-49 (2)	6-525 (2)
AMS (1)	5-52 (2)	6-545 (2)



6-565 (2)	11-95 (2)	32-57 (2)
6-575 (2)	11-95 (2)	32-67 (2)
6-576 (2)	11-97 (2)	37-42 (2)
6-577 (2)	11-98 (2)	37-100 (2)
7-11 (2)	11-117 (2)	39-51 (2)
7-12 (2)	11-155 (2)	39-52 (2)
7-15 (2)	11-157 (2)	39-65 (2)
7-16 (2)	11-165 (2)	44-2 (2)
7-25 (2)	11-167 (2)	44-12 (2)
7-26 (2)	11-237 (2)	44-15 (2)
7-45 (2)	11-500 (AA-AC) (2)	44-16 (2)
7-46 (2)	11-500 (RM-RU) (2)	44-35 (2)
7-100 (2)	11-555 (2)	44-36 (2)
8-15 (2)	11-557 (2)	44-37 (2)
8-16 (2)	11-587 (2)	44-235
8-35 (2)	11-592 (2)	44-236 (2)
8-36 (2)	11-597 (2)	44-435 (2)
8-61 (2)	17-22 (2)	44-436 (2)
8-75 (2)	17-25 (2)	44-437 (2)
8-76 (2)	17-26 (2)	44-445 (2)
8-77 (2)	17-35 (2)	44-445 (2)
8-78 (2)	17-36 (2)	44-447 (2)
6-302 (2)	17-42 (2)	44-448 (2)
9-9 (2)	17-45 (2)	44-535 (2)
9-12 (2)	17-46 (2)	44-536 (2)
9-47 (2)	17-51 (2)	44-537
9-76 (2)	17-52 (2)	44-544 (2)
9-87 (2)	17-55 (2)	44-545 (2)
9-217 (2)	17-56 (2)	44-545 (2)
9-227 (2)	17-57 (2)	44-547 (2)
9-377 (2)	17-65 (2)	44-548 (2)
9-500 (AA-AC) (2)	17-66 (2)	55-11 (2)
9-510 (2)	17-85 (2)	55-12 (2)
10-301 (2)	17-86 (2)	55-37 (2)
11-5 (2)	17-100 (2)	55-38 (2)
11-6 (2)	17-105 (2)	55-157 (2)
11-7 (2)	17-106 (2)	55-457 (2)
11-15 (2)	17-107 (2)	55-468 (2)
11-16 (2)	17-408 (2)	55-468 (2)
11-37 (2)	29-1 (2)	55-500 (AA-AE) (2)
11-38 (2)	29-7 (2)	57-5 (2)
11-39 (2)	29-21 (2)	57-42 (2)
11-55 (2)	29-56 (2)	57-100 (2)
11-57 (2)	32-56 (2)	

**NG:** State AG (3); units—same as Active Army except allowance is one copy to each unit.

**USAR:** None.

For explanation of abbreviations used, see AR 230-50.



**Changes in force: C 1, C 3 and C 4, and C 5**

**TM 11-5820-295-20  
C 5**

**CHANGE }  
No. 5 }**

**HEADQUARTERS  
DEPARTMENT OF THE ARMY  
WASHINGTON, D.C., 9 April 1975**

**Organizational Maintenance  
RADIO SET AN/GRC-19**

**TM 11-5820-295-20, 3 June 1960, is changed as follows:**

*Inside front cover.* Radiation warning is added after existing notices.

# WARNING RADIATION HAZARD



**RADIOACTIVE MATERIAL  
CONTROLLED DISPOSAL REQUIRED  
ACCOUNTABILITY NOT REQUIRED**

**STD RW-2**

Ammeter	Ra226	0.59uCi	6625-00-569-0243
Ammeter	Ra226	1.0uCi	6625-00-538-9700
Meter	Ra226	0.69uCi	6625-00-669-0769
	Electron Tube	OA2WA	5960-00-503-4880
EEVC	U238	0.1uCi	
CBSHytron	Ni63	0.5uCi	
Raytheon	Co60	0.2uCi	

**Radiation Hazard Information:** The following radiation hazard information must be read and understood by all personnel before operating or repairing Radio Set AN/GRC-19. Hazardous radioactive materials are present in the above listed components of the T-195/GRC-19, AN/GRC-19A, AN/GRC-19B, and R-392/URR.

The components are potentially hazardous when broken. See qualified medical personnel and the local Radiological Protection Officer (RPO) immediately, if you are exposed to or cut by broken components. First aid instructions are contained in TB43-0116, TB43-0122 and AR755-15.

**NEVER** place radioactive components in your pocket.

Use extreme care **NOT** to break radioactive components while handling them.

**NEVER** remove radioactive components from cartons until you are ready to use them.

If any of these components are broken, notify the local RPO immediately. The RPO will survey the immediate area for radiological contamination and will supervise to removal of broken components. The above listed radioactive components *will not* be repaired or disassembled.

Disposal of broken, unserviceable, or unwanted radioactive components will be accomplished in accordance with the instructions in AR 755-15.

By Order of the Secretary of the Army:

Official:

**FREDC. WEYAND**  
*General, United States Army*  
*Chief of Staff*

**VERNEL BOWERS**  
*Major General, United States Army*  
*The Adjutant General*

**Distribution:**

To be distributed in accordance with DA Form 12-51 (qty rqr block no. 90), Organizational maintenance requirements for AN/GRC-19.



CHANGE }  
No. 6 }

DEPARTMENTS OF THE ARMY  
AND THE AIR FORCE  
WASHINGTON, DC, 27 May 1980

**Organizational Manual  
RADIO SET AN/GRC-19  
(NSN 5820-00-030-0155)**

TM 11-5820-295-20, TO 31R2-2GRC-19-32, 3 June 1960, is changed as follows:

Title of manual is changed as shown above.

*Inside front cover.* Add excessive weight warnings after existing warnings as follows:

**WARNING**

Transmitter, Radio T-195(\*)/GRC-19 weighs approximately 122 pounds. Two persons are required to lift it whenever it is moved. Be very careful when

handling the transmitter to prevent injury to personnel and damage to equipment.

**WARNING**

Receiver, Radio R-390(\*)/URR weighs approximately 52 pounds. Two persons are required to lift it whenever it is moved. Be very careful when handling the receiver to prevent injury to personnel and damage to equipment.

By Order of the Secretaries of the Army, the Navy, and the Air Force:

Official:

**J. C. PENNINGTON**  
*Major General, United States Army  
The Adjutant General*

**E. C. MEYER**  
*General, United States Army  
Chief of Staff*

Official:

**BRYCE POE II**  
*General, USAF, Commander, Air Force  
Logistics Command*

**LEW ALLEN, JR., General USAF**  
*Chief of Staff*

Distribution:

To be distributed in accordance with DA Form 12-51, Organizational maintenance requirements for AN/GRC-19.





TECHNICAL MANUAL

DEPARTMENTS OF THE ARMY

No. 11-5820-295-20

AND THE AIR FORCE

TECHNICAL ORDER

No. 31R2-2GRC19-32

WASHINGTON 25, D. C., 3 June 1960

# RADIO SET AN/GRC-19

	Paragraph	Page
<b>CHAPTER 1. MAINTENANCE INSTRUCTIONS</b>		
<b>Section I. General</b>		
Scope .....	1	2
Tools, materials, and test equipment required .....	2	2
Preventive maintenance .....	3	2
<b>II. Troubleshooting</b>		
Visual inspection .....	4	5
Equipment performance checklist .....	5	9
Tube testing and replacement .....	6	17
Removal and replacement of dial lamps .....	7	21
Removal and replacement of fuses .....	8	22
<b>CHAPTER 2. SHIPMENT AND LIMITED STORAGE</b>		
Disassembly of equipment .....	9	23
Repackaging for shipment or limited storage .....	10	23
<b>APPENDIX. REFERENCES .....</b>		<b>27</b>
<b>GLOSSARY.....</b>		<b>28</b>

---

\*This manual supersedes so much of TM-11-374, 27 April 1954, including C1, 11 January 1956; C2, 27 July 1956; C3, 7 February 1957; and C4, 17 May 1957, as is applicable to the organizational maintenance of the equipment.

# CHAPTER I

## MAINTENANCE INSTRUCTIONS

### Section I. GENERAL

#### I. Scope

a. This manual covers second echelon maintenance of Radio Set AN/GRC-19. The operating instructions for this equipment are contained in TM 11-5820-295-10.

b. Second echelon maintenance of Radio Set AN/GRC-19 consists of the following:

- (1) Preventive maintenance (par. 3).
- (2) Visual inspection (par. 4).
- (3) Troubleshooting (par. 5).
- (4) Replacement of defective tubes (par. 6).
- (5) Replacement of defective dial lamps (par. 7).
- (6) Replacement of defective fuses (par. 8).

c. The differences between models of components of this set are not significant to second echelon personnel.

d. Forward comments concerning this manual to the Commanding Officer, U. S. Army Signal Publications Agency, Fort Monmouth N. J.

*Notes.* For applicable forms and records, see paragraph 2, TM 11-5820-295-10.

#### 2. Tools, Materials, and Test Equipment Required

A list of parts normally stocked for unit repairman's maintenance is contained in TM 11-5820-295-20P. The tools, materials, and test equipment required for unit repairman's maintenance are listed below.

##### a. Tools.

- (1) Tool Equipment TE-41.
- (2) Seven-pin and nine-pin tube pullers (fig. 3 and 4) stored in both the receiver and the transmitter.

##### b. Materials.

- (1) Cleaning Compound (Fed. stock No. 7980-895-9542).
- (2) Cleaning cloth.
- (3) Fine sandpaper.
- (4) Gasket shellac.

c. *Test Equipment.* The only test equipment required is Multimeter AN/URM-105.

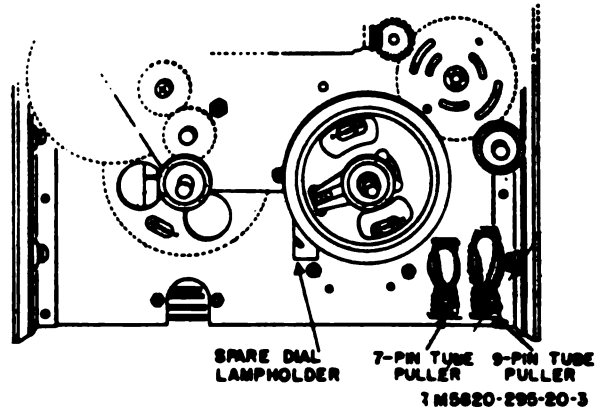

Figure 1. Gear plate, front panel removed, showing location of special tools supplied with receiver.

#### 3. Preventive Maintenance

a. *DA Form 11-238.* DA Form 11-238 (fig. 2 and 3) is a preventive maintenance checklist to be used by the unit repairman. Items not applicable to the equipment are lined out in the figures. References in the item block in the figures are to the paragraph that contains additional maintenance information pertinent to the particular item. Additional preventive maintenance information concerning items 2, 3, 6, and 7 on DA Form 11-238 will be found in the preventive maintenance portion of TM 11-5820-295-10. Instructions for the use of the form appear on the form.

b. *Items.* The information shown in this subparagraph is supplementary to DA Form 11-238. The item numbers correspond to the ITEM numbers on the form. Do not remove any subchassis in the receiver or transmitter to inspect components.

Item	Maintenance procedures
8	Check Rope RP-5, used to tie down whip antenna, for cuts or fraying. Check antenna guy wires for damage, if Antenna Group AN/GRA-12 is used.
9	Check Bag CW-206/GR for mildew, tears, or fraying.

<p><b>ADDITIONAL ITEMS FOR 2D AND 3D ECHELON INSPECTIONS</b></p> <p>26. INSPECT ANTENNA FOR ECCENTRICITIES, CORROSION, LOOSE FIT, DAMAGED INSULATORS AND... .....</p> <p>27. CHECK FOR NORMAL OPERATION.</p> <p>28. DEFECTS-INDICATED-OR-CORRECTED. .....</p> <p>IF DEFICIENCIES NOTED ARE NOT CORRECTED DURING THE INSPECTION, INDICATE ACTION TAKEN FOR CORRECTION.</p>	<p>CONDITION</p> <p style="text-align: center;">✓</p> <p style="text-align: center;">✓</p>	<p style="text-align: center;"><b>MAINTENANCE CHECK LIST FOR SIGNAL EQUIPMENT</b> SOUND EQUIPMENT, RADIO, DIRECTION FINDING RADAR, CARRIER, RADIOSONDE AND TELEVISION (AR 750-635)</p> <p>EQUIPMENT NOMENCLATURE <b>RADIO SET AN/ERC-19</b></p> <p>EQUIPMENT SERIAL NUMBER <b>0000</b></p> <p style="text-align: center;"><b>INSTRUCTIONS</b></p> <p>This form may be used for a period of one month by using the correct dates and weeks of the month. It is to be used as a Preventive Maintenance check list for Signal equipment in actual use, or for a check on equipment prior to issue.</p> <p>1. For detailed Preventive Maintenance instructions see:  a. The Technical Manual (in TM 11 series) for the equipment.  (See DA Pamphlet Number 310-4)  b. The Supply Bulletin (SB 11-100 series) for the equipment.  (See DA Pamphlet Number 310-4)  c. The Department of the Army Lubrication Order.  (See DA Pamphlet Number 310-4)</p> <p>2. The following action will be taken by either the Communications Officer/Chief for 1st echelon, or the Inspector for higher echelon:  a. Enter Equipment Nomenclature and Serial Number.  b. Strike out items that do not apply to the equipment.</p> <p>3. Operator/Inspector will enter in the column entitled <b>CONDITION</b>, on the proper line, a notation regarding the condition, using symbols specified under <b>LEGEND</b>.</p> <p>4. After operator completes each daily inspection he will initial over the appropriate dates under "Daily Condition for Month", then return form to his supervisor.</p>																								
		<p style="text-align: center;"><b>TYPE OF INSPECTION</b></p> <table border="1" style="width:100%; border-collapse: collapse;"> <thead> <tr> <th style="width: 15%;">OPERATION</th> <th style="width: 15%;">2/3 ECHELON</th> <th style="width: 40%;">DATE</th> <th style="width: 30%;">SIGNATURE</th> </tr> </thead> <tbody> <tr> <td></td> <td style="text-align: center;">✓</td> <td style="text-align: center;">2 Mar 1960</td> <td style="text-align: center;"><i>John Greenberg</i></td> </tr> <tr> <td></td> <td></td> <td></td> <td></td> </tr> <tr> <td></td> <td></td> <td></td> <td></td> </tr> <tr> <td></td> <td></td> <td></td> <td></td> </tr> <tr> <td></td> <td></td> <td></td> <td></td> </tr> </tbody> </table>	OPERATION	2/3 ECHELON	DATE	SIGNATURE		✓	2 Mar 1960	<i>John Greenberg</i>																
OPERATION	2/3 ECHELON	DATE	SIGNATURE																							
	✓	2 Mar 1960	<i>John Greenberg</i>																							

**DA FORM 11-238**  
REPLACES DA FORMS 11-239, 1 NOV 58; 11-239, 1 MAR 1959; 11-242, 11-250, 11-256, AND 11-251; WHICH ARE OBSOLETE.

Figure 2. DA Form 11-238, pages 1 and 4.

DAILY CONDITION FOR MONTH OF

MARCH 1960

NO.	DAILY ITEM	CONDITION EACH WEEK					2D 3D ECH	CONDITION
		1ST	2D	3D	4TH	5TH		
<p><b>LEGEND for marking conditions:</b> Satisfactory, Y; Adjustment, Repair or Replacement required, X. Defect corrected, C.</p>								
<p>1. COMPLETENESS AND GENERAL CONDITION OF EQUIPMENT. (Transmitters, receiver, carrying cases, mags, cables, microphones, tubes, spare parts, technical manual).</p>								
<p>2. CLEAN DIRT AND MOISTURE FROM ANTENNA, MICRO-PHONES, HEADSETS, KEYS, JACKS, PLUGS, COMPONENT PANELS.</p>								
<p>3. INSPECT CONTROLS FOR NORMAL OPERATION. TAP CONTROLS LIGHTLY FOR EVIDENCE OF CUT-OUT FROM LOOSE CONTACTS.</p>								
<p>4. CHECK FOR NORMAL OPERATION OF EQUIPMENT. BE ALERT FOR UNUSUAL OPERATION OR CONDITION. BE</p>								
<p><b>WEEKLY</b></p>								
5.	CLEAN AND TIGHTEN EXTERIORS OF CASES, -MOUNTS, MOUNTS, TRANSMISSION LINES,						✓	
6.	INSPECT CASES, MOUNTS, ANTENNA -MOUNTS AND EXPOSED METAL SURFACES FOR RUST, CORROSION.						✓	
7.	INSPECT CORDS, CABLE, WIRE, SHOCK MOUNTS FOR CUTS, KINKS, BREAKS, PRAYING, UNDOUE STRAIN.						✓	
8.	CHECK ANTENNA GUY WIRES FOR PROPER TENSION OR DAMAGE. PAR. 3						✓	
9.	INSPECT CANVAS AND LEATHER ITEMS FOR MILDEW, TEARS, PRAYING. PAR. 3						✓	
10.	INSPECT ACCESSIBLE ITEMS FOR LOOSE-NESS; SWITCHES, KNOBS, JACKS, CONNECTORS, RELAYS, TRANSFORMERS, MOTORS, PILOT -LIGHTS, BLOWERS, ETC. PAR. 3						✓	
11.	CLEAN AND/OR INSPECT AIR FILTERS, BRASS NAME PLATES, DIAL AND METER WINDOWS.						✓	
12.	INSPECT - - - - -						✓	
<p><b>ADDITIONAL ITEMS FOR 2D AND-3D-ECHELON INSPECTIONS</b></p>								
13.	INSPECT SHELTERS AND COVERS FOR ADEQUACY OF WEATHER-PROOFING. TEARS, PRAYING.						✓	
14.	CHECK - - - - -						✓	

CONTINUED ON PAGE 4

Figure 3. DA Form 11-238, pages 2 and 3.

## Section II. TROUBLESHOOTING

### 4. Visual Inspection

Many of the faults in the radio set may be found by inspecting the system components. When troubleshooting, get as much information as possible from the operator as to the operation of the set before trouble appeared. Before starting a detailed examination of the component parts, check for the following common troubles.

**Caution:** When servicing the transmitter, be careful with the power-supply circuits and the plate circuits. The high voltages in these circuits can cause serious injury or death. When the transmitter is taken out of its case for servicing, connect a ground wire to the main frame before connecting the power cable. Use #12 AWG wire (or larger) for the ground wire. Make sure that the transmitter is turned off and disconnected from the power source before working on any high-voltage circuits. Discharge the high-voltage capacitors by shorting them to ground with a grounding rod. The grounding rod should have an insulated handle. Use a strong alligator clip and a copper-braid

strap to make a good ground connection.

a. Improper setting of the switches and controls (TM 11-5820-295-10).

b. Improper connection of the cables, headset cord, or antenna lead-in wire (TM 11-5820-295-10).

c. Worn, broken, or disconnected cables, plugs, or headset cord.

d. Grounded or broken antenna or antenna lead-in wire.

e. Poor ground connections.

f. Transmitter interlock switch S611 open. (Transmitter case is not screwed on tightly.)

g. Burned-out fuses. (This usually indicates other troubles.)

h. Loose or broken wires.

i. Improper seating of cables (between the subchassis) in the transmitter or in the receiver.

j. Check for defective tubes (par. 6).

k. If a transmitter that was used on a voice or continuous wave (cw) circuit is installed on a circuit using FSK operation, see that plug P801 is in jack J101 and that plug P601 is in jack J620 in the transmitter.

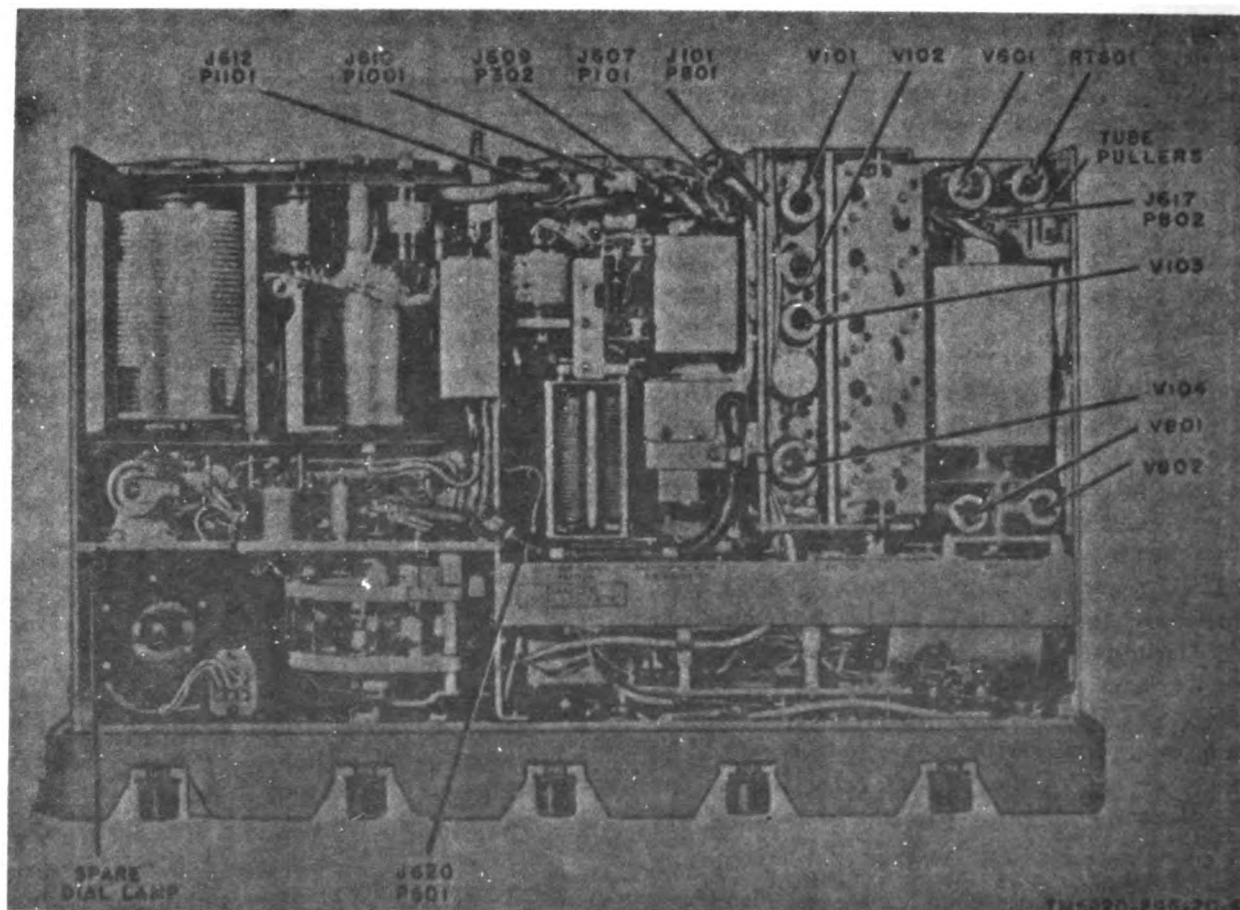

**Figure 4. Transmitter tube and plug locations, top view.**

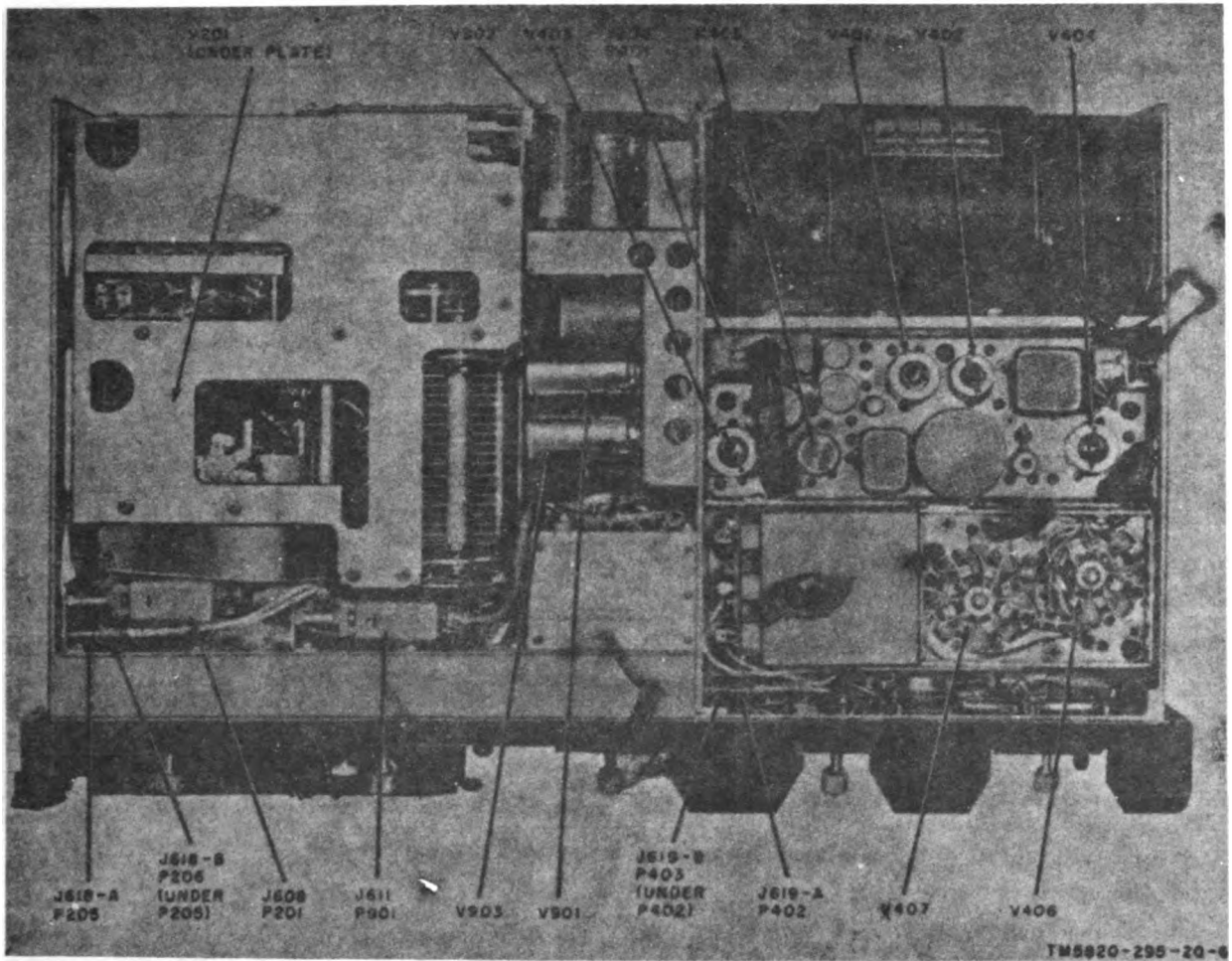

**Figure 5. Transmitter tube and plug locations, bottom view.**

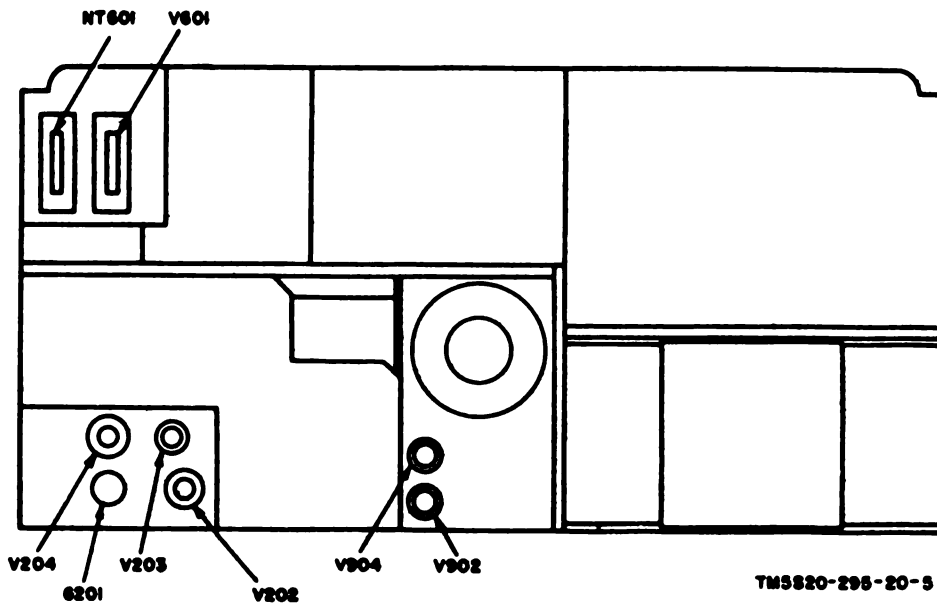

**Figure 6. Transmitter tube and plug locations, rear view.**

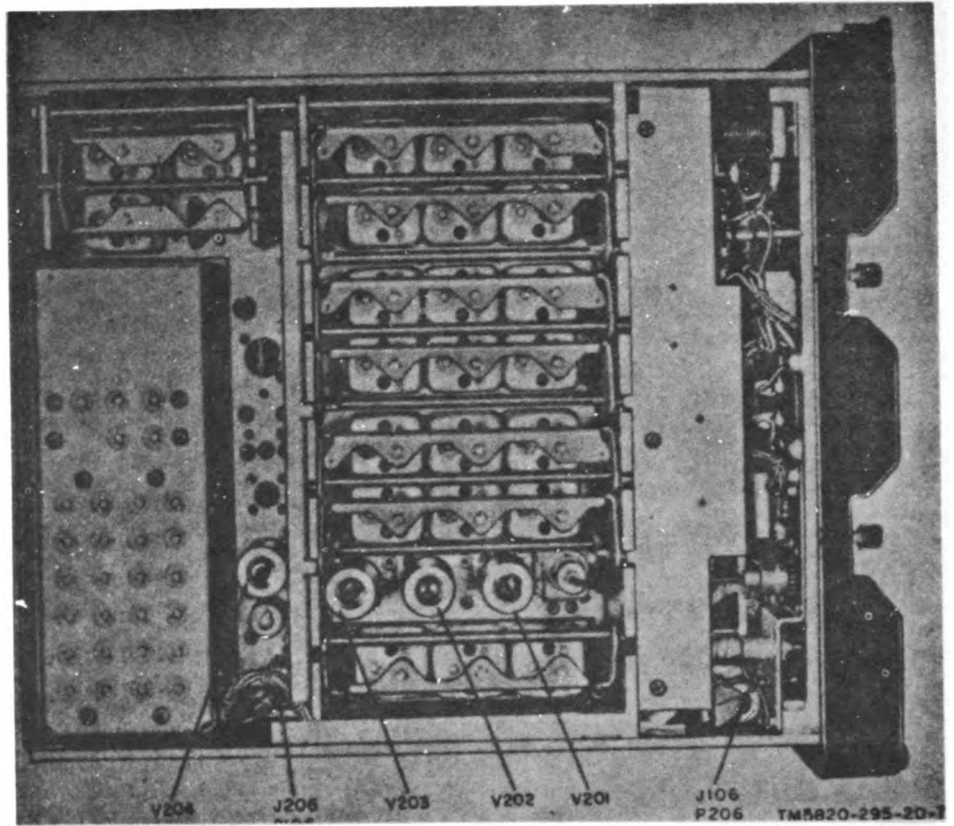

**Figure 7. Receiver tube and plug locations, top view.**

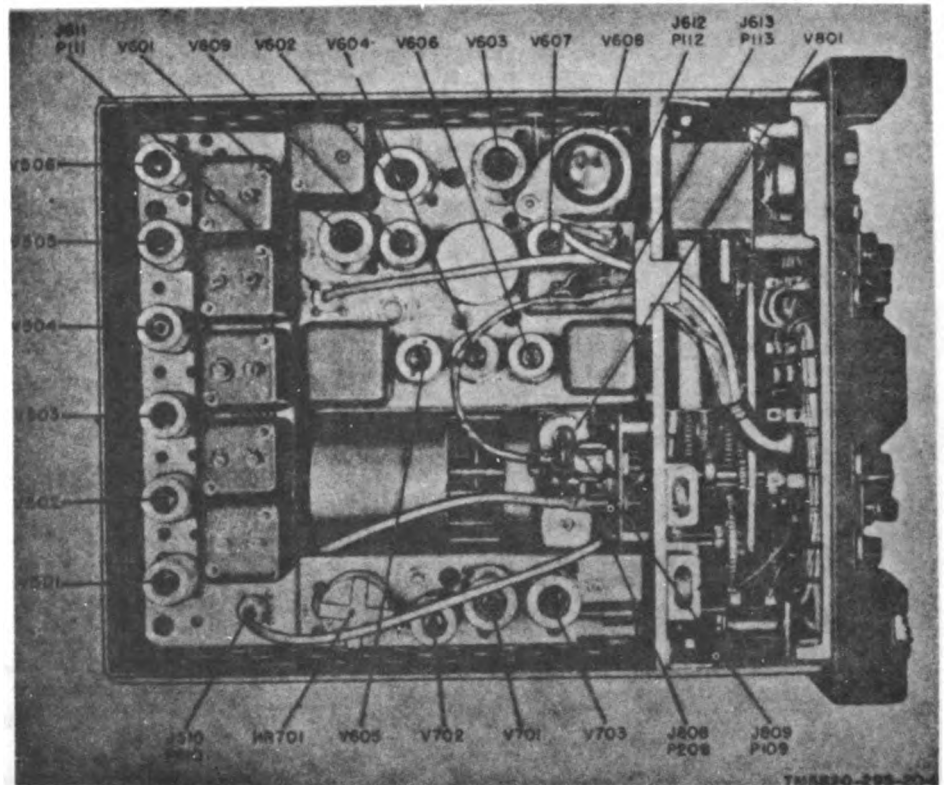

**Figure 8. Receiver tube and plug locations, bottom view.**



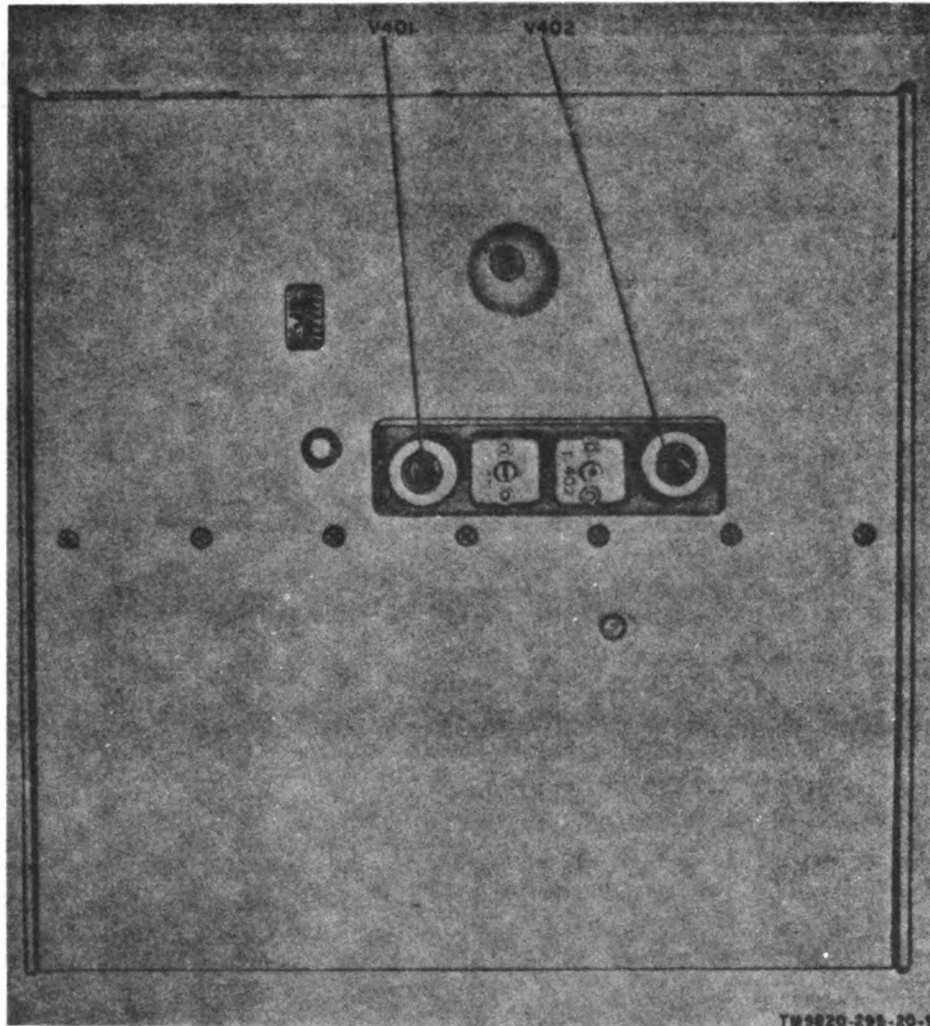

Figure 9. Receiver tube locations, rear view.

## 5. Equipment Performance Checklist

*a. General.* The equipment performance checklist is used to check the equipment performance systematically. All corrective measures which the unit repairman can perform are given in the *Corrective measures* column. When using the checklist, start at the beginning and follow each step in order. If the corrective measures indicated do not correct the trouble, refer the equipment to the next

higher maintenance echelon. Note the trouble symptom on the repair tag and indicate what corrective measures were taken.

**Caution:** Before the transmitter is turned on for troubleshooting or testing, make sure that it is connected to an antenna or a dummy antenna.

*b. Procedure.* Check Radio Set AN/GRC-19 as described in (1) below. Check transmitter Control C-822/GRC-19 as described in (2) below.

*Procedure (cont)*

	Step	Unit	Action	Normal indication	Corrective measures
	1	Transmitter	Set the SERVICE SELECTOR switch at OFF.		
	2	Transmitter	Set the DIAL DIM switch at FULL.		
	3	Transmitter	Set the RELAY NORMAL DUPLEX switch at NORMAL.		
	4	Transmitter	Set the TEST METER switch at BATT.		
	5	Transmitter	Lock the locking bar on the BAND SELECTOR switch.		
	6	Transmitter	Lock the locking bar on the TUNING CONTROL.		
P	7	Transmitter	Set the PRESET CHANNELS switch at the desired channel.		
R		Receiver	Set the function switch at OFF.		
E	9	Receiver	Set the BFO switch at OFF.		
P	10	Receiver	Set the AGC switch at ON.		
A	11	Receiver	Set the AF GAIN control at the center of its range.		
R	12	Receiver	Set the BAND WIDTH switch at 8.		
A	13	Receiver	Set the DIAL DIM switch at ON.		
T	14	Receiver	Turn the RF GAIN control all the way to the right (clockwise).		
O					
R					
Y					

**Procedure (cont)**

	Step	Unit	Action	Normal indication	Corrective measures
S T A R T	15	Transmitter	Set the <b>SERVICE SELECTOR</b> switch at <b>CALIB.</b> (Allow the equipment to warm up for 5 minutes.)	Test meter indicates normal battery voltage and the dial lamps light.  Movement of air is felt at the air vents.  Lv dynamotor starts within 40 seconds $\pm 10$ seconds.	<p>If there is no indication, check front-panel <b>FUSE 15AMP 24-VOLT</b>, power cable connections, and dial lamps.</p> <p>If fuse keeps burning out, the transmitter is probably defective. Refer to <b>TM 11-806</b>.</p> <p>If meter reading is incorrect, check the voltage of the power source. (Adjust to 28.5v.)</p> <p>Check for proper seating of <b>J610</b> in <b>P1001</b> and <b>J612</b> in <b>P1101</b> (fig 4).</p> <p>Make sure that the interlock switch is closed, by tightening the 16 Allen-head screws.</p> <p>Check for proper seating of <b>J606</b> in <b>P401</b> (fig. 5).</p> <p>Check dynamotor fuse <b>F602</b> (10 amp).</p> <p>Check the <b>LINE 5AMP</b> fuse and the dial lamps.</p> <p>Check the interconnecting cable between the transmitter <b>RECEIVER CONT</b> receptacle and the receiver <b>POWER INPUT-TRANS CONT</b> receptacle.</p> <p>Check for proper seating of <b>J106</b> in <b>P206</b> (fig. 7).</p>
	16	Receiver	Set the function switch at <b>STANDRY.</b>	Dial lamps light.	

*b. Procedure (cont)*

	Step	Unit	Action	Normal indication	Corrective measures
E Q U I P M E N T  P E R F O R M A N C E	17	Transmitter	Set the TEST METER switch at PA GRID.	Test meter indicates within shaded area marked PA GRID.	Check these connectors for proper seating: J101 in P801 (fig. 4); J607 in P101; J617 in P802; J608 in P201 (fig. 5).  If the test-meter reading is low, check these tubes by substitution: V801 (fig. 4), V802, V101, V102, V103, V104, V801, and V801 (fig. 5 and 7).
	18	Transmitter	Set the PRESET CHANNELS switch at M.		
	19	Transmitter	Unlock the locking bar on the BAND SELECTOR switch.		
	20	Transmitter	Unlock the locking bar on the TUNING CONTROL.		
	21	Transmitter	Turn the BAND SELECTOR switch to each of the 10 bands in turn, and, while on each band, turn the TUNING CONTROL to the low and high end of the band.	Test meter indicates within the shaded area marked PA GRID.	Check these tubes by substitution: V101, V102, and V103 (fig. 4).

Step	Unit	Action	Normal indication	Corrective measures
22	Transmitter	Set the <b>SERVICE SELECTOR</b> switch at CW.	Hv dynamotor starts within 10 seconds.	Check dynamotor fuse F608 (30 amp).
23	Transmitter	Set the <b>TEST METER</b> switch at PA CATH.	Test meter indicates zero.	Check tube V203 (fig. 7).
24	Transmitter	Hold the <b>TEST KEY</b> at ON.	<p><b>TUNING INDICATOR</b> lights, goes out, lights again, and remains lighted after a slight delay of not more than 30 seconds.</p> <p><i>Note.</i> If the transmitter has been manually tuned from one frequency to another in the same band, or manually tuned to the same frequency in another band, the <b>TUNING INDICATOR</b> may not light or may light and remain lighted. In this case, switch the <b>BAND SELECTOR</b> switch to an adjacent band and back again, and wait for the tuning cycle to be completed.</p>	<p>Check the <b>TUNING INDICATOR</b> lamp. Check the antenna connections and the ground connections.</p>
25	Transmitter	<p>Turn the <b>BAND SELECTOR</b> switch to each one of the 10 bands in turn, and, while on each band, turn the <b>TUNING CONTROL</b> to the low and high end of the band. Hold the transmitter <b>TEST KEY</b> at the ON position after each frequency setting. (Wait until each tuning cycle is finished for each frequency setting before proceeding to the next one.)</p>	<p>400-cycle sidetone can be heard in the headset.</p> <p>After the tuning cycle is finished, the test meter indicates within the shaded area marked PA CATHODE. The <b>TUNING INDICATOR</b> will stay lighted and the 400-cycle sidetone is heard in the headset.</p> <p><i>Note.</i> Refer to note in No. 24 above.</p>	<p>Check these connectors for proper seating: J607 in P101, J609 in P302 (fig. 4), J611 in P301, J608 in P301, J618-A in P205, and J618-B in P206 (fig. 5).</p> <p>Check these tubes by substitution: V201, V201, and V203 (fig. 5); V202, V202, V204, V202, and V204 (fig. 6).</p> <p>If Antenna Group AN/GRA-12 is being used, change the length of the antenna slightly.</p> <p>Check the headset and the headset cord.</p> <p>Check tube V403 (fig. 5).</p> <p>Check for proper seating of J606 in P401 (fig. 5).</p> <p>Same as step No. 24 above.</p>
26	Transmitter	Release the <b>TEST KEY</b> .	<p>The <b>TUNING INDICATOR</b> is not lighted.</p> <p>The test meter reads zero.</p> <p>The 400-cycle sidetone signal is not heard in the headset.</p>	<p>Check the telegraph key and the telegraph key cable.</p>
27	Telegraph key	Hold the telegraph key closed.	<p>The test meter indicates within the shaded area marked PA CATHODE.</p> <p>The <b>TUNING INDICATOR</b> stays lighted.</p> <p><i>Note.</i> Refer to the note in step No. 24 above.</p> <p>The 400-cycle sidetone signal is heard in the headset.</p>	

EQUIPMENT PERFORMANCE

	Step	Unit	Action	Normal indication	Corrective measures
E Q U I P M E N T  P E R F O R M A N C E	28 29	Telegraph key Transmitter	Release the telegraph key. Set the SERVICE SELEC- TOR switch at STAND BY.	The dynamotors stop. The test meter reads zero. The TUNING INDICATOR is not lighted. No sound is heard in the headset.	
	30	Transmitter	Set SERVICE SELEC- TOR switch at VOICE/ FSK	The dynamotors do not start. The TUNING INDICATOR is not lighted. The test meter reads zero.	
	31	Microphone	Press the microphone switch  Talk into the microphone. Speak normally and hold the microphone about 2 inches from the lips.	The dynamotors start.  The TUNING INDICATOR stays lighted. <i>Note.</i> Refer to the note in step No. 24 above. The test meter indicates in the shaded area marked PA CATHODE, and the pointer moves slightly while the operator is talking. The audio level meter reads up to 100 on the peaks. The voice sidetone signal is heard in the headset.	Check these connectors for proper seating: J606 in P401. (fig. 5).  Check these tubes by sub- stitution: V401, V402, V403, V404, V406, and V407 (fig. 5).  Check the microphone and the microphone cord.
	32	Transmitter	Lock the locking bar on the BAND SELECTOR switch.		
	33	Transmitter	Lock the locking bar on the TUNING CON- TROL.		
	34	Transmitter	Press the reminder spring on the PRESET CHAN- NELS switch. Turn the switch from the M posi- tion to each of the posi- tions which have channels preset. At each position, check for accuracy the reading on the frequency indicator.  (Wait until the drive motor stops before turning the PRESET CHANNELS switch to a new channel.)	As the switch is set at each channel, the BAND SELECTOR switch and the TUNING CONTROL will turn. This will tune the transmitter to a frequency that is shown on the fre- quency indicator. Within limits, the reading on the frequency indicator will agree with the frequency written on the chart for each channel.	If the frequency indicator shows a frequency that differs by more than 20 kc from the frequency as- signed to the channel, or if there is any doubt as to the true output frequency, re- calibrate the channel. Refer to TM 11-806.
	35	Transmitter	Set the DIAL DIM switch at OFF.	The dial lamps are not lighted.	
	36	Transmitter	Set the DIAL DIM switch at DIM.	The dial lamps light dimly.	Replace the dial lamps that do not light.
	37	Transmitter	Set the DIAL DIM switch at FULL.	The dial lamps light fully.	
	38	Receiver	Set the function switch at NORMAL.		

Step	Unit	Action	Normal indication	Corrective measures
30	Receiver	Set the MEGACYCLES control to each band in turn. Turn the KILOCYCLES control through its entire range at each setting of the MEGACYCLES control.  Adjust the MEGACYCLES and KILOCYCLES controls to receive a voice signal.	A signal or a rushing noise is heard in the headset, and the CARRIER LEVEL meter shows the strength of the received signal or noise. CARRIER LEVEL meter rises and dips as the KILOCYCLES control is varied.	If nothing is heard in the headset, and the CARRIER LEVEL METER does not indicate, check PLATE $\frac{1}{2}$ AMP fuse (on the front panel). If the meter does indicate, check the headset and its connections.  Check the rf cable connections and the transmitter antenna connections. Check the seating of the connecting cables between the subchassis.
40	Receiver	Turn AF GAIN control through its entire range.	The signals heard in the headset become louder as the control is turned to the right clockwise.	Check these tubes by substitution: V606, V606, V607, and V608 (fig. 8).
41	Receiver	Turn the ANT TRIM control through its entire range.	The CARRIER LEVEL meter shows increasing and decreasing signal strength. (Leave the control set for the greatest signal strength.)	Check the following tubes by substitution: V201, V202, V203, V204, V501, V502, V503, V504, V505, V609, and V801 (fig. 7 and 8).
42	Receiver	Turn the BAND WIDTH switch from 8 to 4KC, to 2.	The selectivity becomes sharper. This is indicated by less background noise in the 4KC position and the least background noise in the 2 position.	Check tube V503 (fig. 8).
43	Receiver	Turn the BAND WIDTH switch to 8. Set the function switch at LIMITER.	If noise and static are being received with the signal, the noise peaks are reduced in strength.	Check tube V608 (fig. 8).
44	Transmitter	Set the function switch at NORMAL. Hold the TEST KEY at ON.	The receiver is silenced; nothing is heard in the headset.	Check the interconnecting cable between the TRANSMITTER RECEIVER CONT receptacle and the POWER INPUT-TRANS CONT receptacle on the receiver.
45	Transmitter	Release the TEST KEY.	The signal is heard in the headset.	
46	Transmitter	Disconnect the cable from the RECEIVER ANTENNA receptacle.		
47	Receiver	Disconnect the cable from the ANT receptacle.		
48	Receiver	Connect another antenna or a long wire to the ANT receptacle or ANT binding post.		
49	Receiver	Set the function switch at NET.		

EQUIPMENT PERFORMANCE

	Step	Unit	Action	Normal indication	Corrective measure
E Q U I P M E N T  P E R F O R M A N C E	50	Transmitter	Set the RELAY NORMAL DUPLEX switch at RELAY.	The receiver is not silenced; the signal is heard in the headset.	Check the interconnecting cable between the transmitter RECEIVER CONT receptacle and the POWER INPUT-TRANS CONT receptacle on the receiver.
	51	Transmitter	Set NORMAL RELAY DUPLEX switch at NORMAL.		
	52	Receiver	Set the function switch at SQ.		
	53	Receiver	Turn the RF GAIN control to the left (counterclockwise) so that the signal heard in the headset disappears. Rotate the control clockwise until the signal is barely heard.		
	54	Receiver	Turn the KILOCYCLES control through its entire range.	There is a minimum of noise as the receiver is tuned between stations (or when listening to a voice-operated station) and the receiver is quiet between transmissions.	Check these tubes by substitution: V603 and V605 (fig. 8).
	55	Receiver	Set the function switch at NORMAL.		
	56	Receiver	Adjust the KILOCYCLES control until a voice signal is heard in the headset.		
	57	Receiver	Set the AGC switch at OFF.	The signal heard in the headset increases in strength.	Check these tubes by substitution: V601, and V602 (fig. 8).
	58	Receiver	Set the BFO switch at ON.		
	59	Receiver	Adjust the KILOCYCLES control until a cw signal is heard in the headset.	Sharp, clear cw signals are heard in the headset.	Check tube V504 (fig. 8).
	60	Receiver	Turn the BFO PITCH control through its entire range.	The tone of the cw signal changes.	
	61	Receiver	Set the AGC switch at CAL		
	62	Receiver	Turn the KILOCYCLES control through its entire range.	A beat note is heard in the headset, and the CARRIER LEVEL meter pointer moves at every 100-ke point on the frequency indicator below 20 mc.	Check these tubes by substitution: V701, V702, and V703 (fig. 8).
	63	Receiver	Set the DIAL DIM switch at OFF.	The dial lamps are not lighted.	
	64	Receiver	Set the DIAL DIM switch at DIAL DIM.	The dial lamps light dimly.	Replace the dial lamps that do not light.
	65	Receiver	Set the DIAL DIM switch at ON.	The dial lamps light fully.	
66	Receiver	Set the function switch at STAND BY.	The receiver is silenced; nothing is heard in the headset. The dial lamps stay lighted.		



	Step	Unit	Action	Normal indication	Corrective measure
S T O P	67	Transmitter	Set the SERVICE SELECTOR switch is OFF.	The transmitter is shut off.	
	68	Receiver	Set the function switch at OFF.	The receiver is shut off.	

Step	Action	Normal indication	Corrective measure
1	Set SERVICE SELECTOR switch at OFF.		
2	Set SERVICE SELECTOR switch at VOICE.	Movement of air is felt at the air vents.	Check the interconnecting cable between the transmitter REMOTE CONT receptacle and the Transmitter Control C-822/GRC-19.
3	Set PRESET CHANNELS switch at a position for which a channel has been preset.	BAND SELECTOR switch and TUNING CONTROL will turn. This will tune the transmitter to the frequency shown on the frequency indicator.	Check the interconnecting cable between the transmitter REMOTE CONT receptacle and the Transmitter Control C-822/GRC-19.
4	Press the microphone switch.	The dynamotors start. The TUNING INDICATOR stays lighted.	Check the interconnecting cable between the transmitter REMOTE CONT receptacle and the Transmitter Control C-822/GRC-19 and the TUNING INDICATOR lamp.
5	Talk into the microphone.	The test meter indicates in the shaded area marked PA CATHODE, and the pointer moves slightly while the operator is talking. The audio level meter reads up to 100 on the peaks. The voice sidetone signal is heard in the headset.	Check the interconnecting cable between the transmitter REMOTE CONT receptacle and the Transmitter Control C-822/GRC-19.
6	Set SERVICE SELECTOR switch at OFF.		

## 6. Tube Testing and Replacement

a. *General.* Inspect all cabling, connections, and the condition of the equipment before attempting to replace any tubes. Try to isolate the trouble to a particular stage or section so that needless replacement and testing of tubes is avoided.

- (1) If a tube tester is available, remove and test one tube at a time. *Do not discard tubes* merely because they fall *on, or slightly below*, the minimum acceptable value. These tubes may provide satisfactory performance for a long period of time while near this test value.
- (2) If a tube tester is not available, troubleshoot the tubes by using the tube substitution method as follows:

(a) Replace the suspected tube with a tube known to be good condition. If the substituted tube does not correct the trouble, replace the original tube. Continue to substitute tubes until the trouble is corrected.

(b) Remove the tube shields by pressing down and turning one-fourth turn counterclockwise. Do not rock or rotate any tube when removing it. Pull the tube straight up; use the proper tube puller. Be sure that the corrugated metal inserts are in place when replacing the tube shields.

- (3) Do not replace or discard tubes merely because they have been in use for some time. If the tube operates properly in the circuit, it should not be replaced.

- (4) Only discard tubes when the defect is obvious, such as a broken envelope, open filament, broken pin, or if a tube tester or the equipment shows it to be defective.

*b. Checking Tubes by Substituting Spares.*

Tune the receiver to a voice frequency that is not fading. Turn the AGC switch to ON, turn the function switch to NORMAL, and turn the RF GAIN control all the way to the right (clockwise). *Make the substitution one tube at a time.* Tap the tube under test; if noise or an abnormal change in volume is heard, replace the tube. Usually, a considerable decrease in the carrier level indicated on the meter for tubes in those stages up to and including the second if amplifier (or a noticeable decrease in volume or quality of the signal heard in the headset) indicates a weak or defective tube. However, different test results for the following tubes must be observed:

- (1) When V609 (age-if amplifier) is weak, an *increase* in volume and a *decrease* in the carrier level indicated on the meter will result.
- (2) When V601 (if cathode follower) is weak, the signal from the IF OUT connector will be weak (indicated by the abnormal operation of the radioteletype converter that is connected to this connector); when a very strong signal is received, the receiver may block and prevent passage of the signal to the IF OUT connector. When V602 (rf and if agc rectifier) is weak or defective, an *increase* in volume or a *lower* indication on the CARRIER LEVEL meter will result.
- (3) A change in volume or quality of the output signal will result if V608A (detector) is defective. To test V608B (noise limiter), tune the receiver away from the test signal a slight amount so that a noisy signal is received; then turn the function switch to LIMITER. The substituted tube should be effective in reducing the noise. To check V605 (squelch control), turn the

function switch to SQ, and tune the receiver from one signal to another. As the receiver is tuned between signals, it should be silenced. After this test, return the function switch to NORMAL and retune the receiver to the test signal.

- (4) When checking V604 (bfo), turn the BFO switch to ON, turn the BFO PITCH control, and listen for a changing beat note.
- (5) To test V701, V702, and V703 (calibration-oscillator circuit), turn the AGC switch to CAL, and tune through *at least* eleven 100-kc calibration points in *each* band. A peak should be seen on the CARRIER LEVEL meter at each 100-kc point below 20 mc and the last two numbers on the frequency indicator should be 00 (two zeros).

*c. Receiver Filament Circuits.* When looking at glass tubes or (when feeling metal tubes) for burned-out filaments, it may be found that more than one tube is not lighted. This condition can be caused by one filament burning out in a circuit having two or three filaments in series. The tubes with the 26-volt filaments are connected in parallel directly across the 28-volt power source. However, those filaments that operate at a lower voltage are connected in series circuits, and may include two or three filaments. An open filament in one stage will cause another stage to appear defective. The table below lists the tubes in each series-filament circuit. Tubes not listed in the table have filaments connected directly across the 28-volt filament line. All tubes in each series circuit are located on the same subchassis. Refer to figures 7, 8, and 9 for tube locations.

---

Series filament circuits (receiver)

---

V401 and V402 (crystal-oscillator subchassis)  
 V601, V606 and V607 (af subchassis)  
 V602 and V608 (af subchassis)  
 V701 and V703 (calibration-oscillator subchassis)

---

Reference symbol	Use	Type	Location	Figure Reference
V201 V202 V203 V204	1st rf ampl 2d rf ampl 1st mixer 2d mixer	26A6 26A6 26C6 26C6	Rf subchassis	7
V401 V402	1st xtal osc 2d xtal osc	6AJ5 6AJ5	Xtal oscillator subchassis	9
V501 V502 V503 V504 V505 V506	1st if ampl 2d if ampl 3d if ampl 4th if ampl 5th if ampl 5th if ampl	26A6 26A6 26A6 26A6 26A6 26A6	If subchassis	8
V601A V601B V602A V602B V602A V603B V604 V605 V606 V607 V608 V609	If cathode follower 1st rf agc rect Rf and if agc rect Squelch rect Detector Noise limiter Bfo Squelch control 1st of ampl Phase inverter 2d of ampl Agc if ampl	12AU7 12AU7 12AU7 26A6 6AJ5 6AJ5 6AJ5 26A7 26A6	Af subchassis	8
V701 V702 V703A V703B	Multivibrator 200-ke xtal osc Harmonic ampl Distorter	12AU7 26A6 12AU7	Calibration oscillator subchassis	8
V801	Vfo-mixer	26D6	Vfo-mixer subchassis	8

*d. Receiver Tubes.* The reference symbol, use, type, location, and figure reference of each of the 25 tubes in the receiver are listed in the following table:

*e. Transmitter Filament Circuits* (fig. 10). When visually inspecting the tubes for burned-out filaments, it may be discovered that more than one tube is not lighted. Eight main filament branches are fed from the 24-volt supply. If V203 is open, branch No. 1 will be entirely inoperative. If V204 is open, resistor R234 will limit the current through V203 making V203 inoperative, and R121 will limit the current through V101 if V102 or V103 is open. If V101, V102, or V103 is open, branch No. 2 will be inoperative. If V104 or V202 is open, branch No. 3 is inoperative. Branches No. 4 and No. 5 are similar series filament strings. The failure of either branch No. 4 or No. 5 does not make the other branch inoperative, but, if

one of the tubes in the branch is open, the whole branch is inoperative. If V404 is open, branch No. 6 is inoperative. If V402, V401, or V403 is open, resistor R417 limits current though V404 making it inoperative. Branch No. 7 consists only of V201. This tube has a 26-volt filament and operates directly from the 24-volt supply through the low resistance of F602 and CR601. Branch No. 8 consists of V406 and V407 in parallel. Both V406 and V407 have 26-volt filaments and operate directly from the 24-volt supply through the low resistance of F602 and CR601. When SERVICE SELECTOR switch S606 is in STANDBY position, the three tubes of branches No. 7 and No. 8 are connected to 24 volts, through R622 and R623. Because of the voltage drop across R623 and R622, the voltage to V201, V406, and V407 is reduced approximately 20 percent. Branches No. 7 and No. 8 are also

connected to 24 volts through CR601, F602, and contacts of dynamotor start relay K602 when the microphone switch or the key is closed. This arrangement allows full filament voltage to be applied during operation. During periods of standby, the back resistance of CR601 is high enough to prevent operation of the dynamotor. A defective fuse F601 or de-

fective relay K608 will cause all filament branches to be inoperative. If F602 or CR601 are defective, the tubes in branches No. 7 and No. 8 will have filament voltage reduced at all times. Resistors R234, R121, and R417 also limit the current through the branches which they parallel.

Reference symbol	Use	Type	Location	Figure Reference
V101 V102 V103 V104	1st multiplier 2d multiplier 3d multiplier Driver	6AU6WA 6AK6 6AK6 5768	Exciter subchassis	4
V201 V202 V203 V204A V204B	Power ampl Clamper 3d servo ampl 1st servo ampl 2d servo ampl	4X150D 5768 6005/6AQ5W 5751	Power-amplifier subchassis	5 and 6
V401A V401B V402 V403A V403B V404A V404B	Preamplifier 1st audio ampl Limiter Sidetone ampl Antenna delay 2d audio ampl Phase inverter	12A77  5726/6AL5W 12A77  5814A	Modulator subchassis	5
V406 V407	Modulator Modulator	4X150D 4X150D		
V601	Voltage regulator	0A2	Main frame	4
V801 V802	Oscillator Buffer ampl	5749/6BA6W 5749/6BA6W	Master-oscillator subchassis	4
V901A  V901B V902 V903A V903B V204	1st phasing ampl  2d phasing ampl 3d phasing ampl 1st loading ampl 2d loading ampl 3d loading ampl	5751  6005/6AQ5W 5751  6005/6AQ5W	Antenna-network and servo-ampl subchassis	5 and 6

f. *Transmitter Tubes.* The reference symbol, use, type, location, and figure reference of

each of the 21 tubes in the transmitter are listed in the following table:

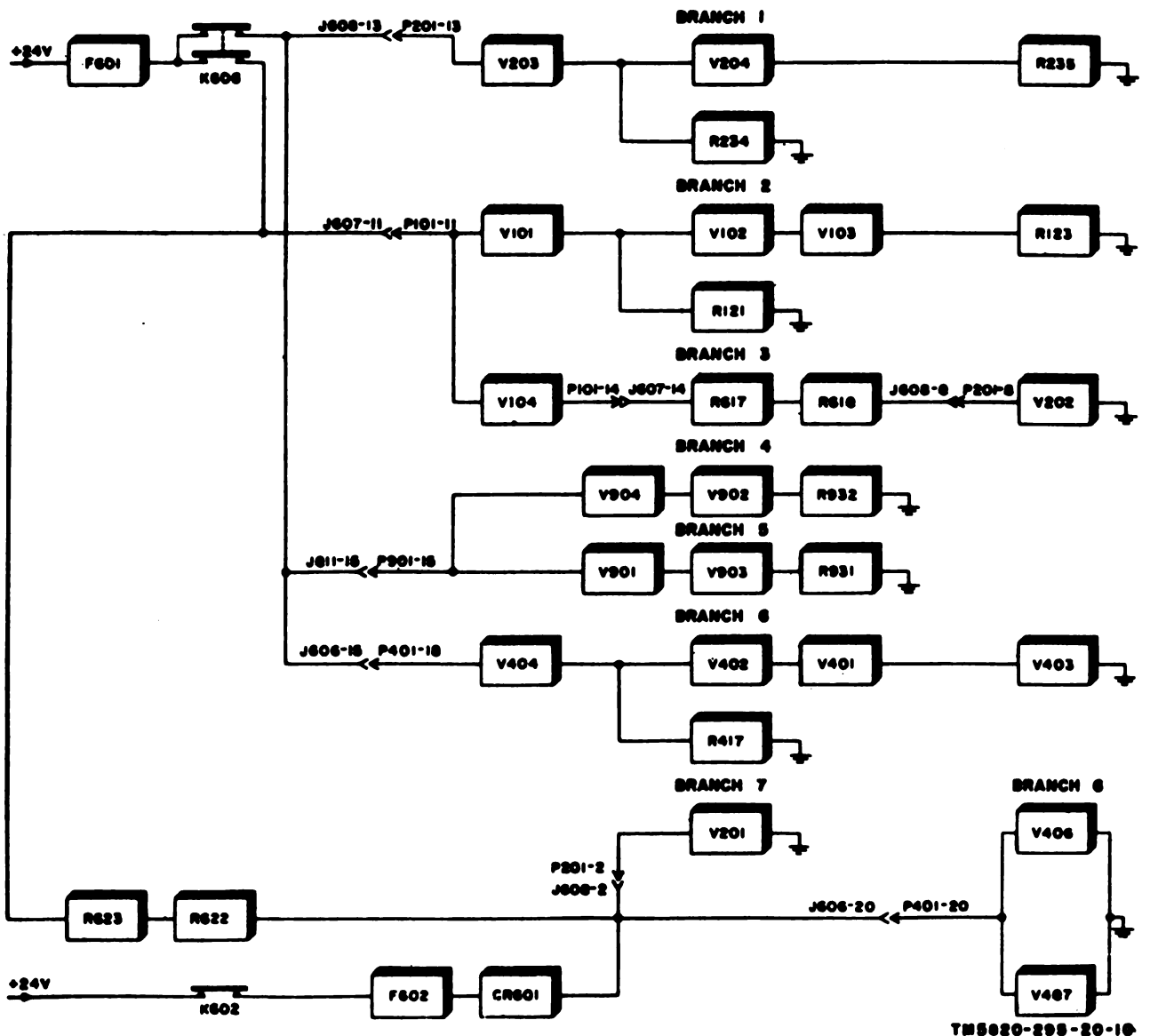

TM5020-298-20-10

Figure 10. Filament circuits of transmitter, simplified block diagram.

*g. Preferred-Type Tubes.* The chart below lists the preferred-type tube for each non-preferred-type tube. Do not use a nonpreferred-type tube to replace a preferred-type tube.

Nonpreferred-type tube	Preferred-type tube	Where used
6AU6	6AU6WA	First multiplier.
5814	5814A	Second audio, phase inverter stages.
12AT7	12AT7WA	Preamplifier, sidetone amplifier, and antenna delay stages.

## 7. Removal and Replacement of Dial Lamps

*Notes.* When replacing the indicator windows, apply gasket shellac to the gaskets to keep the window watertight.

*a. Transmitter.* To remove dial lamp I601 from the BAND and CHAN indicator, remove the six screws that hold the indicator window and take off the window and its gasket. To remove the bayonet-type lamp, turn it to the left (counterclockwise). To remove dial lamps I602 and I603 from the frequency indicator, remove the 12 screws, and take off the window and its gasket. These lamps are removed in the same way as I601. A spare lamp

is located on the main frame of the transmitter (fig. 4). To reach this spare lamp, loosen the 16 Allen-head screws on the front panel and pull the transmitter partly out of its case. To replace TUNING INDICATOR lamp I605, turn the glass indicator jewel to the left (counterclockwise) and remove the lamp in the same way as the others.

b. *Receiver.* To remove dial lamps I201 and I202 from the frequency indicator, remove the 10 screws that hold the indicator window and take off the window and its gasket. To remove the bayonet-type lamps, turn them to the left (counterclockwise). A spare lamp is located on the main frame of the receiver (fig. 1). To reach this spare lamp, loosen the

16 Allen-head screws on the front panel, and pull it partly out of its case.

### 8. Removal and Replacement of Fuses

a. *Transmitter.* To remove FUSE 15AMP 24VOLT from the front panel, push in on the fuseholder cap and turn it to the left (counterclockwise). To replace fuses F602 and F603 on the front panel, slide the latch up on the DYNAMOTOR FUSES cover and remove the cover.

b. *Receiver.* To remove the LINE 5AMP and PLATE  $\frac{1}{2}$ AMP fuses, push in on the fuseholder cap and turn it to the left (counterclockwise). Remove the spare SPARE 5AMP and SPARE  $\frac{1}{2}$ AMP fuses in the same way.

## CHAPTER 2

### SHIPMENT AND LIMITED STORAGE

#### 9. Disassembly of Equipment

The following instructions are recommended as a guide for preparing the radio set for shipment and storage.

##### a. Disconnection of Cables.

- (1) Disconnect the telegraph key and all audio accessories from their receptacles on the units and coil the cords neatly.
- (2) Disconnect all interconnecting cables between the units (TM 11-5820-295-10).
- (3) Disconnect the antenna lead-in wire from the transmitter and antenna mast base, and coil the wire neatly.
- (4) Disconnect the power cable from the transmitter and vehicle battery. Coil the cable neatly.
- (5) Disconnect the grounding strap from the mounting to the vehicle.

##### b. Removal of Units.

- (1) Loosen the three retaining clamps on the lower front edge of the transmitter. Slide the transmitter case forward until the lower rear edge slides out from under the four clamps at the rear of the mounting and remove the transmitter. Remove the receiver in the same way. There are only two retaining clamps and two rear clamps on the receiver side of the mounting.
- (2) Unscrew the eight bolts and nuts that secure the mounting in place and remove the mounting.

##### c. Removal of Antenna.

- (1) Untie Rope RP-5 from the top of the antenna and from the rear of the vehicle. Coil the rope neatly.
- (2) Loosen the antenna sheath clamp and slide the clamp partly up the antenna.
- (3) Slide the antenna cover partly up the antenna.
- (4) Unscrew Mast Section MS-116-A section from the mast base.
- (5) Slide the antenna cover and the antenna sheath clamp down and off Mast Section MS-116-A.

- (6) Unscrew Mast Section MS-118-A from Mast Section MS-117-A.
- (7) Unscrew the MS-117-A section from the MS-116-A section.
- (8) Unscrew the MS-116-A sections from each other.

#### 10. Repackaging for Shipment or Limited Storage

The exact procedure for repackaging depends on the material available and the conditions under which the equipment is to be shipped or stored. Adapt the procedures outlined below whenever possible. The information concerning the original packaging (TM 11-5820-295-10) will also be helpful.

a. *Material Requirements.* The following materials are required for packaging Radio Set AN/GRC-19. For stock numbers of materials, consult SB 38-100.

Material	Quantity
Waterproof wrapping paper.	75 sq. ft.
Fiberboard corrugated single face (flexible).	81 sq. ft.
Waterproof adhesive tape.	50 ft.
Steel strapping ( $\frac{5}{8}$ x 0.020).	
Note. Steel strapping is required only for intertheater shipments.	

b. *Packaging.* Package the components of Radio Set AN/GRC-19 as follows:

- (1) *Technical manuals* (fig. 11). Package each technical manual within a close-fitting bag fabricated of waterproof wrapping paper. Seal the bag securely with water-proof, pressure-sensitive tape.
- (2) *Bag CW-806/GR* (fig. 12). Place the minor components within the designated compartment of the bag. Fold the bag and secure it with its fastening devices. Wrap the bag with corrugated fiberboard and overwrap with waterproof wrapping paper. Secure the overwrap with waterproof, pressure-sensitive tape

(3) *Radio Receiver R-392/URR* (fig. 11). Place the running spares for the receiver within Case CY-1298/URR. Close and secure the case lid with its fastening devices. Wrap the case with corrugated fiberboard. Secure the wrap with pressure-sensitive tape. Wrap the receiver with corrugated fiberboard. Secure the wrap with pressure-sensitive tape. Place the wrapped case and wrapped receiver together and wrap with corrugated fiberboard and overwrap with waterproof wrapping paper. Secure the overwrap with waterproof, pressure-sensitive tape.

(4) *Radio Transmitter T-195/GRC-19* (fig. 12). Place the running spares for the transmitter within Case CY-1451/GRC-19. Close and secure the case lid with its fastening devices. Make sure that the three air vents on the transmitter are closed (yellow side facing out). To close these vents, loosen the catches on each side of the vents, pull out the vents, and reverse them, and then secure the catches. Individually wrap each of the items listed below with corrugated fiberboard and secure the wrap with pressure-sensitive tape. Place the wrapped items together and wrap with corrugated fiberboard and overwrap with waterproof wrapping paper. Se-

cure the overwrap with waterproof, pressure-sensitive tape.

(a) Case CY-1451/GRC-19.

(b) Cable Assembly CG-1127/U.

(c) Cable Assembly CX-1599/U.

(d) Cable Assembly CX-1852/U.

(e) Cable Assembly CX-2583/U.

(f) Radio Transmitter T-195/GRC-19.

(5) *Mounting MT-9851/GRC-19*. No packaging required.

c. *Packing*. Pack the components in wooden boxes as follows:

(1) Place the following items in box No. 1: Radio Transmitter T-195/GRC-19, Case CY-1451/GRC-19, Cable Assembly CG-1127/U, Cable Assembly CX-1599/U, Cable Assembly CX-1852/U, Cable Assembly CX-2583/U, Radio Receiver R-392/URR, Case CY-1298/URR, and technical manuals. The box should be 18 inches high, 50 inches wide, and 18 inches deep.

(2) Place the Bag CW-206/GR in box No. 2. The box should be 12 inches high, 44 inches wide, and 10 inches deep.

(3) Place Mounting MT-851/GRC-19 in box No. 3. Block the mounting within the box with wooden blocks nailed to the inside of the box to prevent movement. The box should be 4 inches high, 36 inches wide, and 16 inches deep.



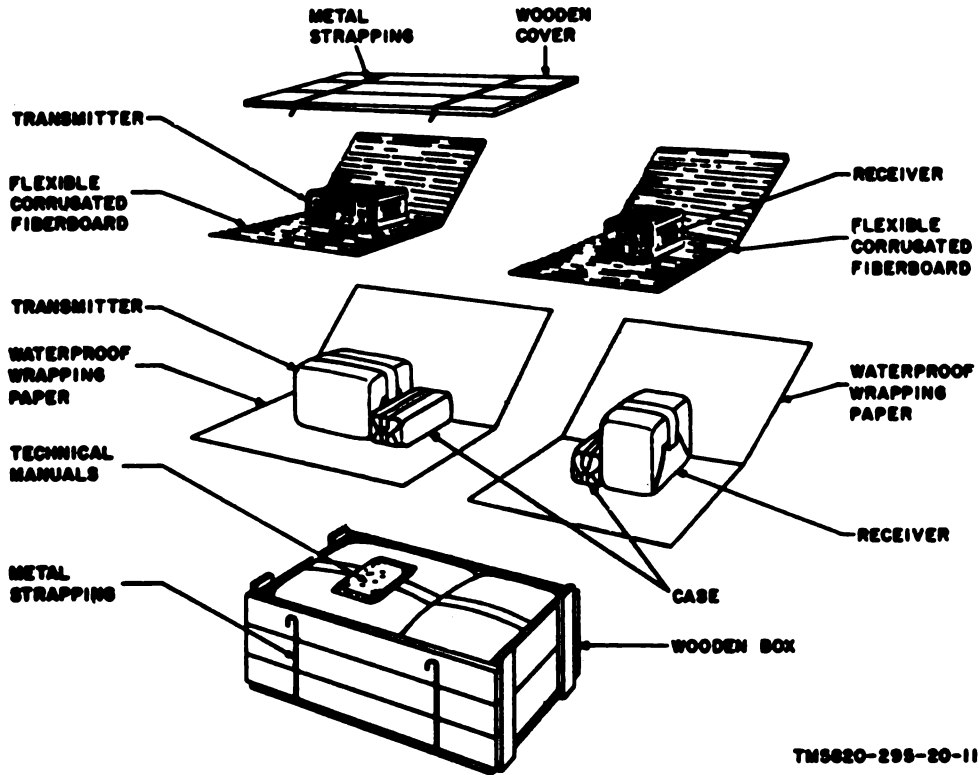

Figure 11. Transmitter, receiver, and literature, repackaging diagram.

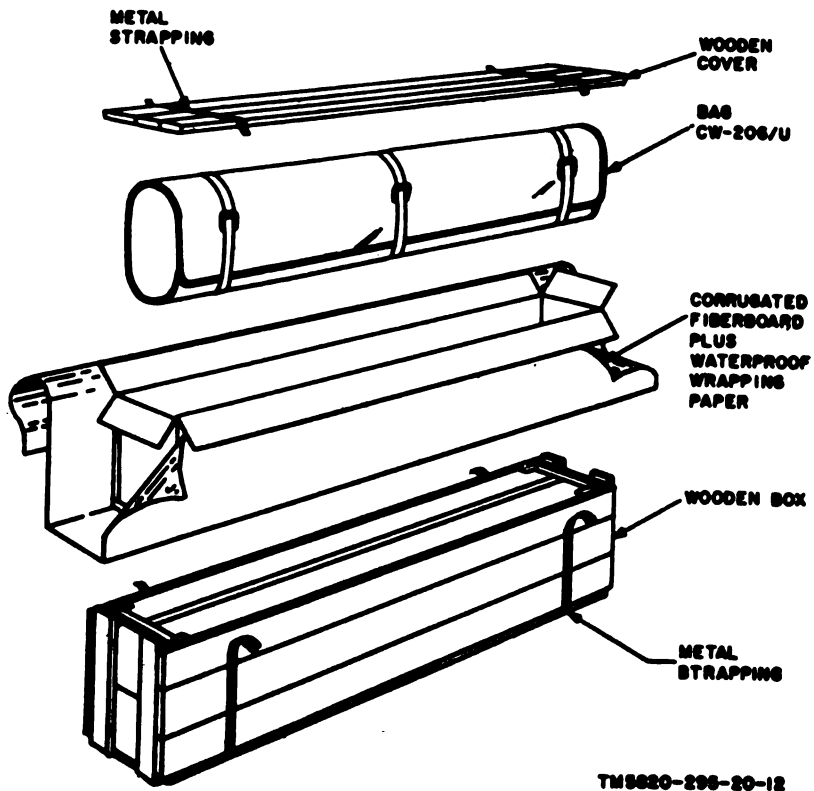
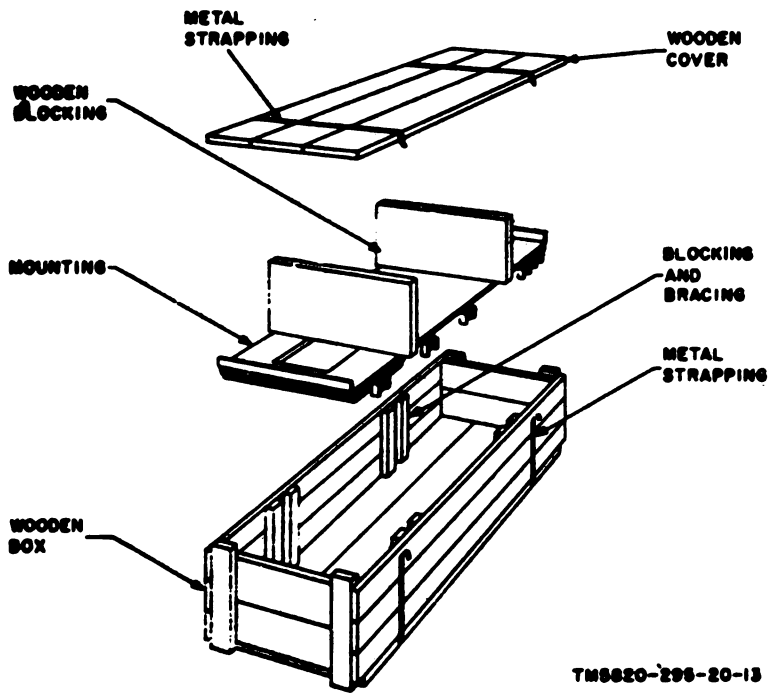

Figure 12. Bag, repackaging diagram.



TM5620-296-20-13

*Figure 13. Mount, repackaging diagram.*

## APPENDIX I REFERENCES

The following is a list of references applicable and available to the unit repairman of Radio Set AN/GRC-19:

SB 38-100	Preservation, Packaging and Packing Material, Supplies, and Equipment Used by the Army.	TM 11-5820-295-20P	Tools List: Radio Set AN/GRC-19.
TM 11-806	Radio Transmitter T-195/GRC-19.	TM 11-5820-334-10P	Organization Maintenance Repair Parts and Special Tools List and Maintenance Allocation Chart for Radio Set AN/GRC-19.
TM 11-858	Radio Receiver R-392/URR.	TM 11-5820-334-20P	Operator's Maintenance Repair Parts and Special Tools List: Receiver, Radio R-392/URR.
TM 11-5820-295-10	Operator's Manual, Radio Set AN/GRC-19.	TM 11-5820-334-20P	Organizational Maintenance Repair Parts and Special Tools List and Maintenance Allocation Chart: Receiver, Radio R-392/URR.
TM 11-5820-295-10P	Operation Maintenance Repair Parts and Special		

# GLOSSARY

---

## Section I. ABBREVIATIONS

af	audio frequency	hf	high frequency
agc	automatic gain control	hv	high voltage
ampl	amplifier	if	intermediate frequency
AWG	American Wire Gage	kc	kilocycle
bfo	beat-frequency oscillator	mc	megacycle
fsk	frequency-shift keyed	rf	radiofrequency

## Section II. DEFINITIONS OF UNUSUAL TERMS

**Autotune**—The name applied to an electromechanical system which automatically positions a shaft to a predetermined setting.

**Frequency-shift keying**—A method of radioteletype keying; the carrier frequency is shifted to a slightly different frequency un-

der certain conditions.

**Sidetone**—An audio-frequency signal used for monitoring transmissions.

**Subchassis**—The name applied to a removable assembly which performs a major function in the receiver or transmitter.

By Order of *Wilber M. Brucker*, Secretary of the Army:

**L. L. LEMNITZER,**  
*General, United States Army,*  
*Chief of Staff.*

Official:

**R. V. LEE,**  
*Major General, United States Army,*  
*The Adjutant General.*

Official:

**J. L. TARR,**  
*Colonel, United States Air Force,*  
*Director of Administrative Services.*

**THOMAS D. WHITE,**  
*Chief of Staff, United States Air Force.*

Distribution:

*Active Army:*

To be distributed in accordance with DA Form 12-7 requirements for TM 11 Series (UNCL) Plus the following Additional Formula:

USASA (1)	5-192 (2)
CNGB (1)	5-215 (2)
Def Atomic Spt Agcy (5)	5-216 (2)
Tech Stf, DA (1) except	5-217 (2)
CSigO (18)	5-218 (2)
USA Abn & Elet Bd (1)	5-225 (2)
USA ATB (1)	5-355 (2)
US ARADCOM (2)	5-356 (2)
US ARADCOM Rgn (2)	5-357 (2)
MDW (1)	5-358 (2)
Seventh US Army (5)	5-359 (2)
EUSA (5)	5-372 (2)
Corps (2)	5-376 (2)
USASCS (25)	5-377 (2)
JBUSMC (2)	5-464 (2)
Units org under fol TOE:	6-37 (2)
1-7 (2)	6-100 (2)
1-17 (2)	6-101 (2)
1-26 (2)	6-125 (2)
1-27 (2)	6-126 (2)
1-37 (2)	6-125 (2)
1-57 (2)	6-126 (2)
1-67 (2)	6-200 (2)
1-107 (2)	6-201 (2)
5-6 (2)	6-300 (2)
5-7 (2)	6-301 (2)
5-8 (2)	6-315 (2)
5-15 (2)	6-316 (2)
5-16 (2)	6-317 (2)
5-17 (2)	6-319 (2)
5-35 (2)	6-325 (2)
5-36 (2)	6-325 (2)
5-37 (2)	6-327 (2)
5-129 (2)	6-300 (2)
5-133 (2)	6-401 (2)
5-167 (2)	6-501 (2)

6-525 (2)	17-51 (2)
6-545 (2)	17-52 (2)
6-575 (2)	17-55 (2)
6-576 (2)	17-56 (2)
6-577 (2)	17-57 (2)
7 (2)	17-62 (2)
7-11 (2)	17-65 (2)
7-12 (2)	17-66 (2)
7-25 (2)	17-65 (2)
7-26 (2)	17-66 (2)
8-15 (2)	17-67 (2)
8-75 (2)	29-56 (2)
8-76 (2)	32-56 (2)
8-77 (2)	32-57 (2)
9-76 (2)	39-51 (2)
9-217 (2)	39-52 (2)
11-5 (2)	39-61 (2)
11-6 (2)	39-71 (2)
11-7 (2)	44-12 (2)
11-15 (2)	44-15 (2)
11-16 (2)	44-16 (2)
11-37 (2)	44-35 (2)
11-38 (2)	44-36 (2)
11-39 (2)	44-37 (2)
11-55 (2)	44-101 (2)
11-57 (2)	44-115 (2)
11-95 (2)	44-116 (2)
11-98 (2)	44-235 (2)
11-117 (2)	44-236 (2)
11-155 (2)	44-435 (2)
11-165 (2)	44-436 (2)
11-167 (2)	44-437 (2)
11-500 (AA-AE) (2)	44-445 (2)
11-555 (2)	44-447 (2)
11-557 (2)	44-448 (2)
11-587 (2)	44-535 (2)
11-592 (2)	44-536 (2)
11-597 (2)	44-537 (2)
17 (2)	44-545 (2)
17-2 (2)	44-547 (2)
17-22 (2)	44-549 (2)
17-25 (2)	55-11 (2)
17-28 (2)	55-12 (2)
17-35 (2)	55-33 (2)
17-36 (2)	55-157 (2)
17-45 (2)	57 (2)
17-46 (2)	57-5 (2)

**NG:** State AG (3); Units—Same as Active Army except allowance is one copy to each unit.

**USAR:** None.

For explanation of abbreviations used, see AR 320-50.

☆ U.S. GOVERNMENT PRINTING OFFICE ; 1988 O - 201-421 (80470)

