

ARMY TM 11-5820-553-23
NAVY EE150-SN-MMO-010/E110 PRC70

ORGANIZATIONAL AND DIRECT SUPPORT MAINTENANCE MANUAL

RADIO SET AN/PRC-70
(NSN 5820-01-062-8246)

This copy is a reprint which includes current
pages from Change 1.

DEPARTMENTS OF THE ARMY, AND THE NAVY

24 JANUARY 1983

WARNING

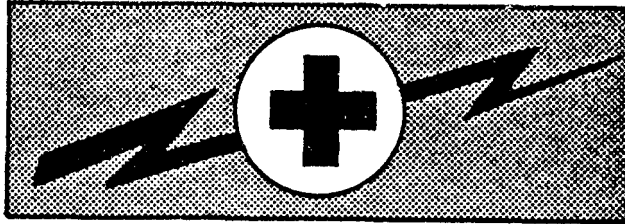

HIGH VOLTAGE

is used in the operation of this equipment

DEATH ON CONTACT

may result if personnel fail to observe safety precautions

Never work on electronic equipment unless there is another person nearby who is familiar with the operation and hazards of the equipment and who is competent in administering first aid. When the technician is aided by operators, he must warn them about dangerous areas.

Whenever possible, the power supply to the equipment must be shut off before beginning work on the equipment. Take particular care to ground every capacitor likely to hold a dangerous potential. When working inside the equipment, after the power has been turned off, always ground every part before touching it.

Be careful not to contact high-voltage connections or 115 volt ac input connections when installing or operating this equipment.

Whenever the nature of the operation permits, keep one hand away from the equipment to reduce the hazard of current flowing through the body.

Warning: Do not be misled by the term "low voltage." Potentials as low as 50 volts may cause death under adverse conditions.

For Artificial Respiration, refer to FM 21-11.

CHANGE

HEADQUARTERS
DEPARTMENT OF THE ARMY
Washington, DC, 1 August 1987

No. 2

ORGANIZATIONAL AND DIRECT SUPPORT
MAINTENANCE MANUAL
RADIO SET AN/PRC-70
(NSN 5820-01-062-8246)

TM 11-5820-553-23/EE150-SN-MMO-010/E110 PRC70, 23 January 1983, is changed as follows:

1. Remove old pages and insert new pages as indicated below. New or changed material is indicated by a vertical bar in the margin of the page. Added or revised illustrations are indicated by a vertical bar adjacent to the identification number.

<i>Remove pages</i>	<i>Insert pages</i>
i and ii	i and ii
1-1 through 1-3/(1-4 blank)	1-1 through 1-3/(1-4 blank)
2-1 and 2-2	2-1 and 2-2
3-25 and 3-26	3-25 and 3-26
4-13 through 4-20	4-13 through 4-20
4-113 through 4-116	4-113 through 4-116
4-119 through 4-122	4-119 through 4-122
4-133 and 4-134	4-133 and 4-134
4-143 through 4-146	4-134 through 4-146
4-157 through 4-168	4-157 through 4-168
A-1/(A-2 blank)	A-1/(A-2 blank)
B-3 through B-12	B-3 through B-12
Figure FO-4	Figure FO-4
Figure FO-5	Figure FO-5
Figure FO-10	Figure FO-10
Figure FO-11	Figure FO-11
Figure FO-12	Figure FO-12

2. Figure FO-2, MODULATOR/SQUELCH block, Unit 1A1A21, lower right: Change "P4" to read "P3."

3. File this change sheet in the front of the publication for reference purposes.

Distribution authorized to the Department of Defense and DOD contractors only for official use or for administration or operational purposes. This determination was made on 26 March 1987. Other requests for this document will be referred to Commander, US Army Communications-Electronics Command and Fort Monmouth, ATTN: AMSEL-ME-P, Fort Monmouth, NJ 07703-5000.

DESTRUCTION NOTICE—Destroy by any method that will prevent disclosure of contents or reconstruction of the document.

By Order of the Secretaries of the Army and the Navy:

Official:

JOHN A WICKHAM, JR.
General, United States Army
Chief of Staff

R. L. DILWORTH
Brigadier General, United States Army
The Adjutant General

GLENWOOD CLARK
Vice Admiral, United States Navy
Commander, Space and Naval Warfare
Systems Command

DISTRIBUTION:

To be distributed in accordance with DA Form 12-51 literature requirements for AN/PRC-70.

CHANGE

No. 1

HEADQUARTERS
DEPARTMENT OF THE ARMY
Washington, DC, 16 December 1983

**ORGANIZATIONAL AND DIRECT SUPPORT
MAINTENANCE MANUAL
RADIO SET AN/PRC-70
(NSN 5820-01-062-8246)**

TM 11-5820-553-23/EE150-SN-MMO-010/E110 PRC70, 24 January 1983, is changed as follows:

1. New or revised material is indicated by a vertical bar in the margin. Where an entire chapter, section, or illustration is added or revised, the vertical bar is placed opposite the identification number and title.
2. Remove old pages and insert new pages as follows:

<i>Remove pages</i>	<i>Insert pages</i>
	Warning page c/(d blank)
i through iv	i through iv
1-1 and 1-2	1-1 and 1-2
2-1 and 2-2	2-1 and 2-2
4-1 and 4-2	4-1 and 4-2
4-5 and 4-6	4-5 and 4-6
4-11 and 4-12	4-11 and 4-12
4-31 through 4-36	4-31 through 4-36
4-39 through 4-42	4-39 through 4-42
4-131 and 4-132	4-131 and 4-132
4-135 and 4-136	4-135 and 4-136
4-145 and 4-146	4-145 and 4-146
4-151 and 4-152	4-151 and 4-152
4-157 and 4-158	4-157 and 4-158
4-161 and 4-162	4-161 and 4-162
4-165 through 4-167	4-165 through 4-168
A-1	A-1/(A-2 blank)
B-3 and B-4	B-3 and B-4
B-9 and B-10	B-9 and B-10

3. File this change sheet in front of the publication.

By Order of the Secretary of the Army:

JOHN A. WICKHAM JR.
General, United States Army
Chief of Staff

Official:

ROBERT M. JOYCE
Major General, United States Army
The Adjutant General

DISTRIBUTION:

To be distributed in accordance with DA Form 12-51A-1,
Organizational Maintenance requirements for AN/PRC-70.



5

SAFETY STEPS TO FOLLOW IF SOMEONE IS THE VICTIM OF ELECTRICAL SHOCK

1

DO NOT TRY TO PULL OR GRAB THE INDIVIDUAL

2

IF POSSIBLE TURN OFF THE ELECTRICAL POWER

3

IF YOU CANNOT TURN OFF THE ELECTRICAL POWER, PULL, PUSH, OR LIFT THE PERSON TO SAFETY USING A WOODEN POLE OR A ROPE OR SOME OTHER INSULATING MATERIAL

4

SEND FOR HELP AS SOON AS POSSIBLE

5

AFTER THE INJURED PERSON IS FREE OF CONTACT WITH THE SOURCE OF ELECTRICAL SHOCK, MOVE THE PERSON A SHORT DISTANCE AWAY AND IMMEDIATELY START ARTIFICIAL RESUSCITATION

FIXED OPERATION WITH LONG RANGE ANTENNAS

WARNING

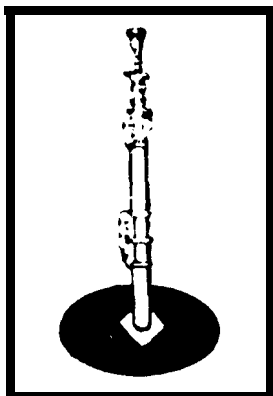

TELESCOPING
ANTENNA MAST

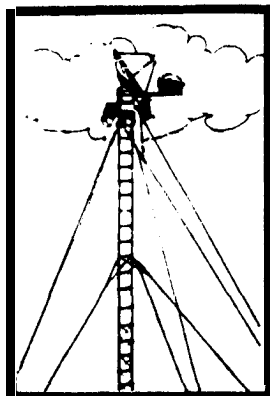

TYPICAL TOWER

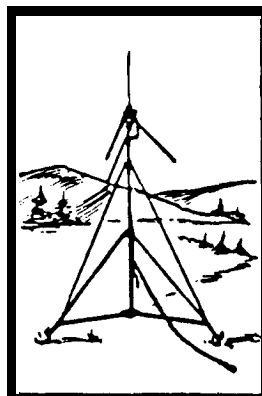

EXTENDED RANGE
ANTENNA

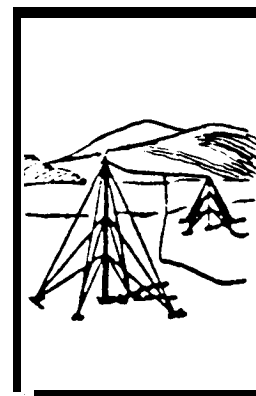

DOUBLET ANTENNA

NEVER ERECT THESE LONG RANGE ANTENNAS DIRECTLY UNDER POWERLINES.

IF YOU MUST ERECT THESE LONG RANGE ANTENNAS NEAR POWERLINES, POWERLINE POLES OR TOWERS, OR BUILDINGS WITH OVERHEAD POWERLINE CONNECTIONS, NEVER PUT THE ANTENNA CLOSER THAN TWO TIMES THE ANTENNA HEIGHT FROM THE BASE OF THE POWERLINE, POLE, TOWER OR BUILDINGS.

NEVER ATTEMPT TO ERECT ANY LONG RANGE ANTENNA WITHOUT A FULL TEAM.

BEFORE ERECTING ANY LONG RANGE ANTENNA, INSPECT ALL THE PARTS MAKING UP THE ANTENNA KIT, DO NOT ERECT THE ANTENNA IF ANY PARTS ARE MISSING OR DAMAGED.

DO AS MUCH OF THE ASSEMBLY WORK AS POSSIBLE ON THE GROUND.

WHEN ERECTING THE ANTENNA, ALLOW ONLY TEAM PERSONNEL IN THE ERECTION AREA.

MAKE SURE THAT THE AREA FOR THE ANCHORS IS FIRM. IF THE GROUND IS MARSHY OR SANDY, GET SPECIFIC INSTRUCTIONS FROM YOUR CREW CHIEF OR SUPERVISOR ON HOW TO REINFORCE THE ANCHORS.

WHEN SELECTING LOCATIONS FOR ANCHORS, AVOID TRAVELED AREAS AND ROADS. IF YOU CANNOT AVOID THESE AREAS, GET SPECIFIC INSTRUCTIONS FROM YOUR SUPERVISOR AS TO WHAT CLEARANCE YOUR GUY WIRES AND ROPES MUST HAVE OVER THE TRAVELED AREAS AND ROAD.

CLEARLY MARK ALL GUY WIRES AND ROPES WITH THE WARNING FLAGS OR SIGNS SUPPLIED BY YOUR UNIT. IN AN EMERGENCY, USE STRIPS OF WHITE CLOTH AS WARNING STREAMERS.

IF YOU SUSPECT THAT POWERLINES HAVE MADE ACCIDENTAL CONTACT WITH YOUR ANTENNA, STOP OPERATING, ROPE OFF THE ANTENNA AREA, AND NOTIFY YOUR SUPERIORS.

IF THE WEATHER IN YOUR AREA CAN CAUSE ICE TO FORM ON YOUR LONG RANGE ANTENNA AND ITS GUY WIRES AND ROPES, ADD EXTRA GUYS TO SUPPORT THE SYSTEM. ROPE OFF THE AREA AND POST IT WITH WARNING SIGNS LIKE "BEWARE OF FALLING ICE".

DO NOT TRY TO ERECT ANY ANTENNA DURING AN ELECTRICAL STORM.

KEEP A SHARP EYE ON YOUR ANCHORS AND GUYS. CHECK THEM DAILY AND IMMEDIATELY BEFORE AND AFTER BAD WEATHER.

WARNING

Adequate ventilation should be provided while using TRICHLOROTRIFLUOROETHANE. Prolonged breathing of vapor should be avoided. The solvent should not be used near heat or open flame; the products of decomposition are toxic and irritating. Since TRICHLOROTRIFLUOROETHANE dissolves natural oils, prolonged contact with skin should be avoided. When necessary, use gloves which the solvent cannot penetrate. If the solvent is taken internally, consult a physician immediately.

TECHNICAL MANUAL
 NO. 11-5820-553-23
 Technical Manual
 No. EE150-SN-MMO-010/E110 PRC70

DEPARTMENTS OF THE ARMY
 AND THE NAVY

WASHINGTON, DC, 24 January 1983

ORGANIZATIONAL AND DIRECT SUPPORT MAINTENANCE MANUAL

RADIO SET AN/PRC-70

(NSN 5820-01-062-8246)

REPORTING ERRORS AND RECOMMENDING IMPROVEMENTS

You can help improve this manual. If you find any mistakes or if you know of a way to improve the procedures, please let us know. Mail your letter, DA Form 2028 (Recommended Changes to Publications and Blank Forms) or DA Form 2028-2 located in back of this manual direct to Commander, US Army Communications-Electronics Command and Fort Monmouth, ATTN: AMSEL-ME-MP, Fort Monmouth, New Jersey 07703-5000. For Navy, mail comments to the Commander, Space and Naval Warfare Systems Command, ATTN: SPAWAR 8122, Washington, DC 20363-5100. In either case, a reply will be furnished direct to you.

		Paragraph	Page
Chapter	1. INTRODUCTION		
SECTION	I. General	1-1	1-1
	II. Description and Data	1-9	1-2
Chapter	2. ORGANIZATIONAL MAINTENANCE INSTRUCTIONS		
SECTION	I. Tools and Equipment	2-1	2-1
	II. Repainting and Refinishing Instructions	2-2	2-1
	III. Preventive Maintenance Checks and Services (PMCS)	2-3	2-1
	IV. Troubleshooting	2-4	2-2
	V. Maintenance of the Radio Set	2-5	2-2
Chapter	3. FUNCTIONING OF EQUIPMENT		
SECTION	I. Receiver-Transmitter Functional Analysis	3-1	3-1
	II. Subassembly Functional Analysis	3-4	3-2
Chapter	4. DIRECT SUPPORT MAINTENANCE INSTRUCTIONS		
SECTION	I. General	4-1	4-1
	II. Tools and Test Equipment	4-2	4-1
	III. Troubleshooting	4-3	4-2
	IV. Maintenance of Receiver-Transmitter RT-1133/PRC-70	4-8	4-137
	V. Direct Support Testing Procedures	4-11	4-150
	VI. Additional Maintenance Instructions	4-14	4-168
Chapter	5. MATERIEL USED IN CONJUNCTION WITH MAJOR ITEM		
APPENDIX	A. REFERENCES		A-1
	B. MAINTENANCE ALLOCATION		
SECTION	I. Introduction		B-1
	II. Maintenance Allocation Chart		B-3
	III. Tool and Test Equipment Requirements		B-9
	IV. Remarks		B-12
APPENDIX	C. EXPENDABLE SUPPLIES AND MATERIALS LIST		
SECTION	I. Introduction		C-1
	II. Expendable Supplies and Materials List		C-2
Index			I-1

LIST OF ILLUSTRATIONS

<i>Figure</i>	<i>Title</i>	<i>Page</i>
2-1	RT Unit, Battery Connection	2-4
3-1	Power and TR Relay 1A1A2, Block Diagram	3-3
3-2	455 kHz IF Gain 1A1A3, Block Diagram	3-4
3-3	Power Supply +1-V/ +5V Regulator 1A1A4, Block Diagram.....	3-7
3-4	Power Supply -5V Regulator 1A1A5, Block Diagram	3-5
3-5	Translator 1A1A6, Block Diagram	3-7
3-6	Upper Loop Divider 1A1A7, Block Diagram	3-8
3-7	Upper Loop Phase Detector 1A1A8, Block Diagram	3-8
3-8	Lower Loop 1A1A9, Block Diagram	3-9
3-9	Oscillator Distributor 1A1A10, Block Diagram	3-10
3-10	Oscillator Digital Divider 1A1A11, Block Diagram	3-12
3-11	Transmit Broadband 1A1A12, Block Diagram	3-13
3-12	Up Converter 1A1A3, Block Diagram	3-13
3-13	First IF Selectivity 1A1A14, Block Diagram	3-14
3-14	First IF AGC and Gain 1A1A15, Block Diagram	3-16
3-15	Second Mixer 1A1A16, Block Diagram	3-17
3-16	Second IF 1A1A17, Block Diagram	3-18
3-17	Pump VFO 1A1A18, Block Diagram	3-19
3-18	IF Selectivity 1A1A19, Block Diagram	3-20
3-19	DC Control 1A1A20, Block Diagram	3-22
3-20	Modulator/ Squelch 1A1A21, Block Diagram	3-23
3-21	455 kHz IF Detector 1A1A22, Block Diagram	3-24
3-22	Audio 1A1A23, Block Diagram	3-26
3-23	Coupler 1A1A24, Block Diagram	3-27
3-24	ALC 1A1A25, Block Diagram	3-27
3-25	Bandswitch 1A1A26, Block Diagram	3-28
3-26	Detector 1A1A27, Block Diagram	3-29
3-27	Harmonic filter 1A1A28, block diagram	3-31
3-28	Power Amplifier and Driver 1A1A29, Block Diagram	3-32
3-29	Quad Assembly 1A1A33, Block Diagram	3-33
4-1	AN/ PRC-70 Direct Support Maintenance Procedures, Block Diagram	4-3
4-2	Initial Receive Evaluation Test Setup	4-5
4-3	Receive Evaluation Test Flow Diagram (Sheet 1 of 2)	4-6
4-3	Receive Evaluation Test Flow Diagram (Sheet 2 of 2)	4-7
4-4	RT-1133/PRC-70 Operator Controls	4-8
4-5	Initial Transmit Evaluation Test Setup	4-12
4-6	Transmit Evaluation Test Flow Diagram (Sheet 1 of 3)	4-14
4-6	Transmit Evaluation Test Flow Diagram (Sheet 2 of 3)	4-15
4-6	Transmit Evaluation Test Flow Diagram (Sheet 3 of 3)	4-16
4-7	Single Sideband Distortion Waveform	4-17
4-8	AM Distortion Waveform	4-18
4-9	Voltage Distribution Test Setup	4-21
4-10	Voltage Distribution Test Point Location	4-22
4-11	Voltage Distribution Troubleshooting Diagram	4-23
4-12	Synthesizer Troubleshooting Diagram	4-25
4-13	Synthesizer Test Point Locations (Sheet 1 of 3)	4-26
4-13	Synthesizer Test Point Locations (Sheet 2 of 3)	4-27
4-13	Synthesizer Test Point Locations (Sheet 3 of 3)	4-28
4-14	Pump VFO 1A1A18 Test Setup	4-29
4-15	Pump VFO 1A1A18 Troubleshooting Diagram	4-30
4-16	Translator 1A1A6 Test Setup	4-31
4-17	Translator 1A1A6 Troubleshooting Diagram	4-32
4-18	Second Mixer 1A1A16 Test Setup	4-33
4-19	Second Mixer 1A1A16 Troubleshooting Diagram	4-34
4-20	Lower Loop 1A1A9 Test Setup	4-35
4-21	Lower Loop 1A1A9 Troubleshooting Diagram	4-36
4-22	Upper Loop Divider 1A1A7 Test Setup	4-37
4-23	Upper Loop Divider 1A1A7 Troubleshooting Diagram (Sheet 1 of 2)	4-38
4-23	Upper Loop Divider 1A1A7 Troubleshooting Diagram (Sheet 2 of 2)	4-39
4-24	Oscillator Distributor 1A1A10 Test Setup	4-40
4-25	Oscillator Distributor Troubleshooting Diagram	4-41

LIST OF ILLUSTRATIONS — Continued

<i>Figure</i>	<i>Title</i>	<i>Page</i>
4-26	Mode (RCV) Test Setup	4-42
4-27	Mode (RCV) Test Point Location (Sheet 1 of 2)	4-43
4-27	Mode (RCV) Test Point Location (Sheet 2 of 2)	4-44
4-28	Mode (RCV) Troubleshooting Diagram (Sheet 1 of 2)	4-45
4-28	Mode (RCV) Troubleshooting Diagram (Sheet 2 of 2)	4-46
4-29	Receive Signal Path Troubleshooting Diagram	4-48
4-30	RF/IF Signal Path Test Setup	4-49
4-31	RF/IF Signal Path Test Point Locations (Sheet 1 of 3)	4-50
4-31	RF/IF Signal Path Test Point Locations (Sheet 2 of 3)	4-51
4-31	RF/IF Signal Path Test Point Locations (Sheet 3 of 3)	4-52
4-32	RF/IF Signal Path Troubleshooting Diagram (Sheet 1 of 3)	4-53
4-32	RF/IF Signal Path Troubleshooting Diagram (Sheet 2 of 3)	4-54
4-32	RF/IF Signal Path Troubleshooting Diagram (Sheet 3 of 3)	4-55
4-33	IF Signal Path Test Setup	4-57
4-34	IF Signal Path Test Point Location	4-58
4-35	IF Signal Path Troubleshooting Diagram (Sheet 1 of 2)	4-59
4-35	IF Signal Path Troubleshooting Diagram (Sheet 2 of 2)	4-60
4-36	Receive Audio Test Setup	4-63
4-37	Receive Audio Test Point Location (Sheet 1 of 2)	4-64
4-37	Receive Audio Test Point Location (Sheet 2 of 2)	4-65
4-38	Receive Audio Troubleshooting Diagram (Sheet 1 of 2)	4-66
4-38	Receive Audio Troubleshooting Diagram (Sheet 2 of 2)	4-67
4-39	AGC Test Setup	4-68
4-40	AGC Test Point Location (Sheet 1 of 2)	4-69
4-40	AGC Test Point Location (Sheet 2 of 2)	4-70
4-41	AGC Troubleshooting Diagram (Sheet 1 of 2)	4-71
4-41	AGC Troubleshooting Diagram (Sheet 2 of 2)	4-72
4-42	Narrow Band Audio Test Setup	4-72
4-43	Narrow Band Audio Test Point Location	4-73
4-44	Narrow Band Audio Troubleshooting Diagram	4-74
4-45	Squelch/Retransmit Test Setup.....	4-75
4-46	Squelch/Retransmit Test Point Location	4-76
4-47	Squelch/Retransmit Troubleshooting Diagram (Sheet 1 of 3)	4-77
4-47	Squelch/Retransmit Troubleshooting Diagram (Sheet 2 of 3)	4-78
4-47	Squelch/Retransmit Troubleshooting Diagram (Sheet 3 of 3)	4-79
4-48	Receive Wide Band Audio Troubleshooting Diagram	4-80
4-49	Receive FSK/CW SINAD Troubleshooting Diagram	4-81
4-50	Receive SINAD Test Setup	4-82
4-51	Receive SINAD Troubleshooting Diagram (Sheet 1 of 3)	4-83
4-51	Receive SINAD Troubleshooting Diagram (Sheet 2 of 3)	4-84
4-51	Receive SINAD Troubleshooting Diagram (Sheet 3 of 3)	4-85
4-52	Transmit Subgroup Isolation Flow Diagram	4-86
4-53	Transmit Subgroup Isolation Test Setup	4-87
4-54	Initial Transmit Signal Path Test Point Location (Sheet 1 of 2)	4-88
4-54	Initial Transmit Signal Path Test Point Location (Sheet 2 of 2)	4-89
4-55	Single Side Band Distortion Waveform	4-90
4-56	A17 Extender Card	4-91
4-57	Transmit RF Signal Path Test Setup	4-92
4-58	Transmit RF Signal Path Test Point Location (Sheet 1 of 2)	4-93
4-58	Transmit RF Signal Path Test Point Location (Sheet 2 of 2)	4-94
4-59	Transmit RF Signal Path Troubleshooting Diagram	4-95
4-60	Transmit RF Dynamic Test Setup (Part 1) Diagram	4-96
4-60.1	Transmit RF Dynamic Test Point Location Guide (Sheet 1 of 2)	4-97
4-60.1	Transmit RF Dynamic Test Point Location Guide (Sheet 2 of 2)	4-98
4-61	Transmit RF Dynamic Test Troubleshooting Diagram (Sheet 1 of 2)	4-99
4-61	Transmit RF Dynamic Test Troubleshooting Diagram (Sheet 2 of 2)	4-100
4-62	100% AM Modulated RF Signal	4-101
4-62.1	Transmit RF Dynamic Test Setup (Part 2) Diagram	4-102
4-63	Transmit IF Signal Path Test Setup	4-104
4-64	Transmit IF Signal Path Troubleshooting Diagram (Sheet 1 of 2)	4-105
4-64	Transmit IF Signal Path Troubleshooting Diagram (Sheet 2 of 2)	4-106
4-65	Transmit IF Signal Path Test Point Locations (Sheet 1 of 2)	4-107
4-65	Transmit IF Signal Path Test Point Locations (Sheet 2 of 2)	4-108
4-66	A17 Extender Card	4-109

LIST OF ILLUSTRATIONS – Continued

<i>Figure</i>	<i>Title</i>	<i>Page</i>
4-67	Transmit IF Signal Path Cable Location Guide	4-110
4-68	Transmit Audio Signal Path Troubleshooting Diagram	4-111
4-69	Transmit Audio Signal Path Test Setup	4-112
4-70	Transmit Audio Signal Path Test Point Locations	4-113
4-71	A17 Extender Card	4-115
4-72	No-Tune Tone Troubleshooting Diagram.	4-116
4-73	No-Tune Tone Transmit Test Setup	4-117
4-74	No-Tune Tone Test Point Locations (Sheet 1 of 3)	4-118
4-74	No-Tune Tone Test Point Locations (Sheet 2 of 3)	4-119
4-74	No-Tune Tone Test Point Locations (Sheet 3 of 3)	4-120
4-75	Sidetone Troubleshooting Diagram (Sheet 1 of 2)	4-121
4-75	Sidetone Troubleshooting Diagram (Sheet 2 of 2)	4-122
4-76	Sidetone Test Setup	4-123
4-77	Sidetone Test Point Locations.	4-124
4-78	NB FM Transmit Audio Troubleshooting Diagram (Sheet 1 of 2)	4-125
4-78	NB FM Transmit Audio Troubleshooting Diagram (Sheet 2 of 2)	4-126
4-79	NB FM Transmit Audio Test Setup.	4-127
4-80	NB FM Transmit Audio Test Point Location (Sheet 1 of 2)	4-128
4-80	NB FM Transmit Audio Test Point Location (Sheet 2 of 2)	4-129
4-81	Transmit CW/FSK Troubleshooting Diagram	4-130
4-82	Transmit CW/FSK Test Setup.	4-131
4-83	Transmit CW/FSK Test Point Locations	4-132
4-84	Transmit Power Out Troubleshooting Diagram (Sheet 1 of 2)	4-133
4-84	Transmit Power Out Troubleshooting Diagram (Sheet 2 of 2)	4-134
4-85	Transmit Power Out Test Setup	4-135
4-86	A12 Broadband Gain Test Setup	4-136
4-87	Closed Loop PA Test Setup (Sheet 1 of 2)	4-138
4-87	Closed Loop PA Test Setup (Sheet 2 of 2)	4-139
4-88	Harmonic Filter/Bandswitch Test Setup	4-140
4-89	Open Loop PA Test Setup	4-141
4-90	Module Locations (Sheet 1 of 2)	4-142
4-90	Module Locations (Sheet 2 of 2)	4-143
4-91	Module Removal	4-144
4-92	Final Receive Performance Test Setup	4-151
4-93	Final Receive Performance Test Flow Diagram (Sheet 1 of 2)	4-153
4-93	Final Receive Performance Test Flow Diagram (Sheet 2 of 2)	4-154
4-94	Final Transmit Performance Test Setup	4-158
4-95	Final Transmit Performance Test Flow Diagram (Sheet 1 of 3)	4-160
4-95	Final Transmit Performance Test Flow Diagram (Sheet 2 of 3)	4-161
4-95	Final Transmit Performance Test Flow Diagram (Sheet 3 of 3)	4-162
4-96	Single-Side Band Distortion Waveform	4-163
4-97	AM Modulation Waveform	4-164
4-98	Frequency Stability Test Setup	4-167
FO-1	RT Unit, Simplified Block Diagram	FO-1
FO-2	RT Unit, Detailed Block Diagram	FO-2
FO-3	Frequency Selector 1A1A1, Block Diagram	FO-3
FO-4	Case Assembly 1A1A30, Interconnection Diagram	FO-4
FO-5	Receiver Exciter Parent Board 1A1A31, Interconnection Diagram (Sheet 1 of 5)	FO-5
FO-5	Receiver Exciter Parent Board 1A1A31, Interconnection Diagram (Sheet 2 of 5)	FO-6
FO-5	Receiver Exciter Parent Board 1A1A31, Interconnection Diagram (Sheet 3 of 5)	FO-7
FO-5	Receiver Exciter Parent Board 1A1A31, Interconnection Diagram (Sheet 4 of 5)	FO-8
FO-5	Receiver Exciter Parent Board 1A1A31, Interconnection Diagram (Sheet 5 of 5)	FO-9
FO-6	Power Amplifier Coupler Parent Board 1A1A32, Interconnection Diagram (Sheet 1 of 3)	FO-10
FO-6	Power Amplifier Coupler Parent Board 1A1A32, Interconnection Diagram (Sheet 2 of 3)	FO-11
FO-6	Power Amplifier Coupler Parent Board 1A1A32, Interconnection Diagram (Sheet 3 of 3)	FO-12
FO-7	Modules 1A1A24, 1A1A26, 1A1A27 Removal and Replacement Diagram	FO-13
FO-8	Receiver-Transmitter Case, Replaceable Parts	FO-14
FO-9	Voltage Distribution Detailed Block Diagram (Sheet 1 of 2)	FO-15
FO-9	Voltage Distribution Detailed Block Diagram (Sheet 2 of 2)	FO-16
FO-10	Synthesizer Detailed Block Diagram.	FO-17
FO-11	IF (RCV) Detailed Block Diagram.	FO-18
FO-12	Audio (RCU) Detailed Block Diagram	FO-19
FO-13	Transmit RF/IF Detailed Block Diagram	FO-20
FO-14	Transmit IF Detailed Block Diagram.	FO-21
FO-15	Transmit Audio Detailed Block Diagram	FO-22

LIST OF TABLES

<i>Table</i>	<i>Title</i>	<i>Page</i>
	AN/PRC-70 Reference Designation and Nomenclature Cross-Reference Listing	1-2
	Organizational Preventive Maintenance Checks and Services	2-2
2-2	Organizational Maintenance Troubleshooting	2-3
4-1	Tools and Test Equipment	4-1
4-2	Receive Evaluation Tests	4-4
4-3	Transmit Evaluation Tests.....	4-13
4-4	Receive Troubleshooting Tests.	4-20
4-5	Upper Loop and Pump Test Limits	4-40
4-6	Transmit Troubleshooting Tests.	4-68
4-7	Final Receive Performance Test.	4-152
4-8	Final Transmit Performance Test	4-159
4-9	Minimum Performance Standards	4-166

CHAPTER 1

INTRODUCTION

Section I. GENERAL

1-1. Scope

This manual contains organizational and direct support maintenance instructions for Radio Set AN/PRC-70 (referred to hereafter as the radio set). Topics covered include equipment functioning, corrective maintenance, troubleshooting, testing, inspection, and modification. Maintenance instructions for auxiliary equipment used with the radio set are contained in separate technical manuals. Refer to appendix A for reference to auxiliary equipment items.

1-2. Consolidated Index of Army Publications and Blank Forms

Refer to the latest issue of DA Pam 310-1 to determine whether there are new editions, changes or additional publications pertaining to the equipment.

1-3. Maintenance Forms, Records, and Reports

a. Reports of Maintenance and Unsatisfactory Equipment. Department of the Army forms and procedures used for equipment maintenance will be those prescribed by DA Pam 738-750, as contained in Maintenance Management Update. Navy personnel will report maintenance performed utilizing the Maintenance Data Collection Subsystem (MDCS) IAW OPNAVINST 4790.2, Vol 3 and unsatisfactory material/conditions (UR submissions) IAW OPNAVINST 4790.2, Vol 2, chapter 17.

b. Report of Packaging and Handling Deficiencies. Fill out and forward SF 364 (Report of Discrepancy (ROD)) as prescribed in AR 735-11-2/DLAR 4140.55/NAVMATINST 4355.73B/AFR 400-54/MCO 4430.3H.

c. Discrepancy in Shipment Report (DISREP) (SF 361). Fill out and forward Discrepancy in Shipment Report (DISREP) (SF 361) as prescribed in AR 55-38/NAVSUPINST 4610.33C/AFR 75-18/MCO P4610.19D/DLAR 4500.15.

1-4. Destruction of Army Electronics Materiel

Destruction of Army electronics materiel to prevent enemy use shall be in accordance with TM 750-244-2.

1-5. Administrative Storage

Administrative storage of equipment issued to and used by Army activities will have preventive maintenance performed in accordance with the PMCS charts before storing. When removing the equipment from administrative storage the PMCS should be performed to assure operational readiness.

1-6. Calibration

The radio set requires no calibration.

1-7. Reporting Equipment Improvement Recommendations (EIR)

a. Army. If your Radio Set AN/PRC-70 needs improvement, let us know. Send us an EIR. You, the user are the only one who can tell us what you don't like about the design. Put it on an SF 368 (Quality Deficiency Report). Mail it to Commander, US Army Communications—Electronics Command and Fort Monmouth, ATTN: AMSEL-PA-MA-D, Fort Monmouth, New Jersey 07703-5000. We'll send you a reply.

b. Navy. Navy personnel are encouraged to submit EIR's through their local Beneficial Suggestion Program.

1-8. Warranty Information

Radio Set AN/PRC-70 is warranted by the contractor for a period of 12 months. It starts on the date of government acceptance indicated on the appropriate DA Form 2408-9. Report all defects in material of workmanship to your supervisor who will take appropriate action through your organization's maintenance shop.

Section II. DESCRIPTION AND DATA

1-9. Purpose and Use

Radio Set AN/PRC-70 (referred to hereafter as radio set) is a medium-to-long range communications set which operates in the frequency range from 2 to 75.9999 MHz in 100 Hz increments. It is operationally compatible with other existing communications systems, and provides a versatile and reliable means of communications between mobile field units and/or fixed base stations. The radio set may be operated in all kinds of weather and terrain. Operating modes include amplitude modulation (AM), single sideband (SSB), continuous wave (CW), frequency modulation (FM), and frequency shift keying (FSK). Provisions have been made to permit the use of a security device with the radio set. Two radio sets may be connected together for retransmission purposes.

1 - 10. Description

A general description with illustrations of the radio set is contained in chapter 1 of TM 11-5820-553-10.

1-11. Tabulated Data

Tabulated data for the radio set is contained in chapter 1 of TM 11-5820-553-10.

1 - 12. Cross-Reference

Table 1-1 is a cross-reference listing of the major units and subassemblies of the AN/PRC-70 radio set. The list identifies each item by reference designation, part no., drawing name, common name and official name.

Table 1-1. AN/PRC-70 Reference Designation and Nomenclature Cross-Reference Listing

Ref Des No.	Part No.	Drawing Name	Common Name	Official Name/ (Provisioning Name)
1A1	SM-B-745601	Receiver-Transmitter RT-1133/PRC-70	RT Unit	Receiver-Transmitter RT-1133/PRC-70(1A1)
1A1A1	SM-D-746495	Frequency Selector Assembly	Freq. Selector	Frequency Selector Assembly (1A1A1)
1A1A2	SM-D-746503	Circuit Card Assy. Power and TR Relay	TR Relay Module	Circuit Card Assembly-Power and TR Relay (1A1A2)
1A1A3	SM-D-746502	Circuit Card Assy. IF	IF Gain Module	Circuit Card Assembly-IF Gain (1A1A3)
1A1A4	SM-D-746507	Circuit Card Assy. + 10, + 5V Power Supply	10V Power Supply Module	Circuit Card Assembly-Power Supply (1A1A4)
1A1A5	SM-D-746506	Circuit Card Assy. -5V Power Supply	-5V Power Supply Module	Circuit Card Assembly-Power Supply (1A1A5)
1A1A6	SM-D-746556	Translator Assy.	Translator Module	Electronic Component Assembly (1A1A6)
1A1A7	SM-D-746484	Circuit Card Assy. Upper Loop Divider	Upper Loop Divider Module	Circuit Card Assembly-Upper Loop Divider (1A1A7)
1A1A8	SM-D-746558	Circuit Card Assy. Upper Loop Phase Detector	Phase Detector Module	Circuit Card Assembly-Upper Loop Phase Detector (1A1A8)
1A1A9	SM-D-746505	Circuit Card Assy. Serial Lower Loop	Lower Loop Module	Circuit Card Assembly-Serial Lower Loop (1A1A9)
1A1A10	SM-D-746568	Printed Circuit Assy. Oscillator Distributor	Oscillator, Distributor	Circuit Card Assembly-Oscillator Distributor (1A1A10)
1A1A11	SM-D-746641	Circuit Card Assy. Oscillator Digital Divider	Digital Divider Module	Circuit Card Assembly-Oscillator Digital Divider (1A1A11)
1A1A12	SM-D-746636	Circuit Card Assy. Transmit Broadband	Transmit Broadband Module	Circuit Card Assembly-Transmit Broadband (1A1A12)
1A1A13	SM-D-745622	Circuit Card Assy. Up Converter	Up Converter Module	Circuit Card Assembly-Up Converter (1A1A13)
1A1A14	SM-D-745617	Circuit Card Assy. First IF Selectivity	IF Selectivity Module	Circuit Card Assembly-IF Selectivity (1A1A14)

Table 1-1. AN/PRC-70 Reference Designation and Nomenclature Cross-Reference Listing-Continued

Ref Des No.	Part No.	Drawing Name	Common Name	Official Name/ (Provisioning Name)
1A1A15	SM-D-745618	Circuit Card Assy. First IF AGC and Gain	First IF Module	Circuit Card Assembly-First IF AGC and Gain (1A1A15)
1A1A16	SM-D-745616	Circuit Card Assy. Second Mixer	Second Mixer Module	Circuit Card Assembly-Second Mixer (1A1A16)
1A1A17	SM-D-745619	Circuit Card Assy. Second IF	Second IF Module	Circuit Card Assembly-Second IF (1A1A17)
1A1A18	SM-D-746559	Circuit Card Assy. Pump VFO	VFO Module	Circuit Card Assembly-VFO Pump (1A1A18)
1A1A19	SM-D-746476	Circuit Card Assy. IF Selectivity	IF Selectivity Module	Circuit Card Assembly-IF Selectivity (1A1A19)
1A1A20	SM-D-745620	Circuit Card Assy. DC Control	DC Control Module	Circuit Card Assembly-DC Control (1A1A20)
1A1A21	SM-D-746468	Circuit Card Assy. Modulator/Squelch	Modulator/Squelch Module	Circuit Card Assembly- Modulator/Squelch (1A1A21)
1A1A22	SM-D-746501	Circuit Card Assy. Detection Module 455 kHz IF	IF Detect Module	Circuit Card Assembly-IF Detection (1A1A22)
1A1A23	SM-D-746463	Circuit Card Assy. Audio	Audio Module	Circuit Card Assembly-Audio (1A1A23)
1A1A23	B4029220	Circuit Card Assy. Audio	Audio Module	Circuit Card Assembly - Audio (1A1A23)
1A1A24	SM-C-746598	Coupler Assy.	Coupler Module	Coupler Assembly (1A1A24)
1A1A25	SM-D-746570	Circuit Card Assy. ALC	ALC Module	Circuit Card Assembly- Automatic Level Control (1A1A25)
1A1A26	SM-D-746604	Bandswitch Assy.	Bandswitch Assy.	RF Transmission Line Switch (1A1A26)
1A1A27	SM-D-745628	Circuit Card Assy. Detector	Detector Module	Circuit Card Assembly-Detector (1A1A27)
1A1A28	SM-D-745629	Circuit Card Assy. Filter Harmonic	Harmonic Filter Module	Circuit Card Assembly-Harmonic Filter (1A1A28)
1A1A29	SM-D-745633	Circuit Card Assy. Pwr. Ampl. and Driver Assy.	PA Module	Circuit Card Assembly-Power Amplifier and Driver (1A1A29)
1A1A30	SM-D-746607	Main Case Assy.	Chassis Assy.	Receive-Transmitter Case (1A1A30)
1A1A31	SM-D-746618	Circuit Card Assy. Rcvr. Exciter Parent Bd.	Receiver/Exciter Parent Board	Circuit Card Assembly- Interconnect Board (1A1A31)
1A1A32	SM-D-746565	Circuit Card Assy. Coupler Inter- connection Board	Coupler Parent Board	Circuit Card Assembly-Power Amplifier Board (1A1A32)
1A1A33	SM-D-746490	Quad Assembly	Quad Assy.	Electronic Component Assembly (1A1A33)
1A1FL1	SM-B-746436 SM-A-746856	Filter, Bandpass Whip Antenna Assy.	Filter Assy. 6 or 9-foot Whip Antenna	Filter, Bandpass Antenna AS-2974/PRC-70
	SM-A-746853	Doublet Antenna Assembly	Doublet Antenna	Antenna AS-2975/PRC-70
	SM-C-746321	Cable Assembly	Maintenance Cable	Power Cable Assembly

Chapter 2

ORGANIZATIONAL MAINTENANCE INSTRUCTIONS

Section I. TOOLS AND EQUIPMENT

2-1. Test Equipment, Tools, and Materials Required

- a. *Test Equipment.* Multimeter AN/ URM-105.
- b. *Tools.* Tool Kit, Electronic Equipment TK-101/G.

c. *Materials.* See appendix C for available materials.

d. *Repair Parts.* See TM 11-5820-553-23P for a list of parts normally stocked for organizational maintenance.

Section II. REPAINTING AND REFINISHING INSTRUCTIONS

2-2. Touchup Painting

When the finish on any metal part of the radio set has been badly scarred or damaged by corrosion, perform the following procedures.

a. Lightly clean the surfaces with sandpaper (appx C) down to bare metal.

NOTE

Refer to the applicable painting and refinishing instructions given in SB 11-573 and TB 43-0118.

CAUTION

Do not paint the following:

- Top Surface of the WHIP terminal.
- GND or WIRE terminals.
- Any of the RT-1133/PRC-70 indicators or connectors.
- Any interior surface of RT unit case or covers.
- Antenna AS-2974/PRC-70 ferrules.
- Antenna AS-2975/PRC-70.

b. Brush a thin coat of zinc chromate primer (appx C) on the bare metal surface (previously painted areas only) to protect it from further corrosion. Allow to dry 4 hours.

c. Brush a thin coat of paint (appx C) on primed metal surface.

Section III. PREVENTIVE MAINTENANCE CHECKS AND SERVICES (PMCS)

2-3. General

Preventive maintenance is the systematic care, inspection, and servicing of equipment to maintain it in serviceable condition, prevent breakdowns, and assure maximum operational capability. Organizational preventive maintenance checks and services (PMCS) are performed quarterly (table 2-1). If your equipment fails to operate, troubleshoot with the proper equipment. Report any deficiencies using the proper forms, see DA Pam 738-750. Always keep in mind the CAUTIONS and WARNINGS, before you operate, while you operate, and after you operate.

a. Quarterly PMCS will be scheduled in accordance with procedures specified in DA Pam 738-750.

b. The *Item No.* in table 2-1 shall be used as a source of item numbers for the *TM number* column on DA Form 2404 (Equipment Inspection and

Maintenance Worksheet) in recording the results of the PMCS.

c. If the equipment fails to meet the criteria in the Procedure column of table 2-1, report the failure in accordance with the procedures specified in DA Pam 738-750.

d. If the equipment must be kept in constant operation, check and service only those items that can be done without disturbing operation. Perform all checks and services when the equipment can be shut down.

e. Some of the routine checks that are not listed in the PMCS table are: cleaning, dusting, washing, checking for frayed cables, stowing items not in use, covering unused receptacles, and checking for loose nuts and bolts. These checks should be done whenever needed.

Section IV. TROUBLESHOOTING

2-4. Organizational Maintenance Troubleshooting Procedures

Perform the organizational maintenance procedure for the radio set. If you determine that the

radio set is defective, perform the troubleshooting operations given in the troubleshooting chart (table 2-2). If the corrective measures given in the chart do not clear the trouble, higher category maintenance is required.

Section V. MAINTENANCE OF THE RADIO SET

2-5. General

Corrective maintenance of the radio set at the organizational maintenance is limited to the following:

a. Cleaning.

(1) Remove dust and loose dirt from the surface of equipment with a clean, soft cloth.

NOTE

See DD 314 (Preventive Maintenance Schedule and Record) to see if Frequency Stability Check is due.

Table 2-1. Organizational Preventive Maintenance Checks and Services - Quarterly Schedule

Item No.	Item to be inspected	Procedure Check for and have repaired or adjusted as necessary
1	Completeness	All component required to make the radio set operational are on hand (appx B) or are available.
2	Publications	TM 11-5820-553-10 and TM 11-5820-553-23P are on hand with latest changes; see DA Pam 310-1 for current publication listing.
3	Modification	Check DA Pam 310-1 to see if any modification work orders (MWO's) are listed for the radio set or its component. All URGENT MWO's must be applied immediately; all NORMAL MWO's must be scheduled.
4	Metal surfaces	Remove rust, corrosion, and fungus; spot-paint bare metal spots.
5	Canvas items	Check canvas items for mildew and torn parts.
6	Antennas	a. Check antennas for damage, corrosion, and proper fit when installed. b. Clean surfaces and threads of antenna sections and elements.
7	Battery assembly	a. Check battery assembly for leakage, corrosion and swelling. b. Remove battery assembly and check the rubber gasket on the bottom of the radio for damage. c. Check to see that serviceable power supply batteries are installed.
8	RT unit	Operate the RT unit in the following modes and verify that satisfactory communications are possible with a distant station in assigned frequencies. a. Voice (AM, SSB and FM) b. CW and FSK.
9	Maintenance power cable 1A9W2	Inspect cable assembly for damage.

Table 2-2. Organizational Maintenance Troubleshooting

Malfunction	Probable cause	Corrective action
1. RT unit inoperative or operates weakly in transmit or receive modes.	Battery defective.	Replace BB-542/U (para 2-6b and c).
2. RT unit will not transmit in any or all modes, or will not receive in any or all modes.	RT-1133/PRC-70 defective.	Replace RT-1133/PRC-70.
3. Faulty voice/CW transmission or reception in any configuration.	a. Incorrect frequency setting.	a. Check setting of FREQUENCY selectors.
	b. With SQUELCH control ON, weak signal unable to trigger squelch.	b. Set SQUELCH to OFF, repeat test.
	c. Battery weak.	c. Replace battery.
	d. Handset H-250A/U defective.	d. Replace H-250A/U.
	e. Headset H-251/U defective.	e. Replace H-251/U.
	f. Keyer KY-116/U defective.	f. Replace KY-116/U.
	g. Cable CX-13101/PRC-70 defective.	g. Replace Cable CX-13101/PRC-70.
	h. RT-113/PRC-70 defective.	h. Replace RT-1133/PRC-70.
4. Faulty operation in portable configuration only.	a. AS-2974/PRC-70 defective (whip antenna).	a. Replace AS-2974/PRC-70.
	b. RT-11331PRC-70 defective.	b. Replace RT-1133/PRC-70.
5. Faulty operation in fixed configurations only.	a. RG-58 cable assembly part of AS-2975/PRC-70	a. Replace RG-58 cable assembly.
	b. Balun defective.	b. Replace Balun.
	c. Improper antenna length.	c. Adjust antenna length.
	d. RT-1133/PRC-70 defective.	d. Replace RT-1133/PRC-70.
6. Faulty operation whenever voice security applique is connected.	Voice security applique defective.	Replace voice security applique.
7. Faulty retransmit mode operation.	a. MK-456/GRC kit defective.	a. Replace MK-456/GRC kit.
	b. Antenna defective.	b. Replace antenna.
	c. RT-1133/PRC-70 defective.	c. Replace RT-1133/PRC-70.

WARNING

Adequate ventilation should be provided when using TRICHLOROTRIFLUOROETHANE. Prolonged breathing of vapor should be avoided. The solvent should not be used near heat or open flame; the products of decomposition are toxic and irritating. Since TRICHLOROTRIFLUOROETHANE dissolves natural oils, prolonged contact with skin should be avoided. When

necessary, use gloves, sleeves, and an apron which the solvent cannot penetrate. If the solvent is taken internally, consult a physician immediately.

(2) Remove grease, fungus, and ground-in dirt with a cloth dampened (not wet) with TRICHLOROTRIFLUOROETHANE (appx C).

(3) Clean control knobs, switches, and indicators with a cloth dampened with mild soap and water.

b. Inspection.

(1) Inspect interconnecting cables, antenna guy ropes and halyards, ground wires, and cords for fraying, cuts, kinks and broken insulation.

(2) Inspect canvas items for mildew, torn, and corroded, broken, or loose buckles and snaps.

(3) Inspect antennas for damage, loose fit, and corrosion.

(4) Inspect RT unit and battery assembly for damage, loose fitting latches, knobs, and switches, and corrosion.

c. Battery Charging. The battery used with the radio set is rechargeable. Refer to TM 11-6140-203-14-3 for charging procedures.

2-6. Radio Set Removal and Replacement

a. General. The procedure for removal and replacement will depend upon the configuration in which the radio set is employed.

(1) *Removal.* Refer to TM 11-5820-553-10 for configuration disassembly procedures. Disassemble only to the extent necessary to remove the defective component.

(2) *Replacement.* Refer to TM 11-5820-553-10 for configuration replacement procedures.

b. Battery Removal.

(1) Position the RT-1133/PRC-70 (RT unit) with battery assembly attached on a flat surface. Ensure PWR switch on RT unit is in the OFF position.

(2) Unfasten battery side latches.

(3) Lift RT unit away from battery (fig. 2-2).

c. Battery Installation.

(1) Place a fully charged battery on a flat surface with latches pulled out and down.

(2) Ensure PWR switch on RT unit is in the OFF position. Place the RT unit over the battery and carefully mate the battery connector with the RT unit connector.

(3) Press the two units together and lock the side latches.

d. Removal of WHIP and ANT Connector Cover Assemblies. Remove self locking screw, two bushings, and two connector assemblies from front of RT case (fig. FO-8, view C).

e. Replacement of WHIP and ANT Connector Cover Assemblies. Assemble loop of cover assembly lanyard between two bushings and assemble to RT case with screw (fig. FO-8, view C).

f. Removal of RXMT/AUDIO and XMODE Connector Covers Assemblies. Remove self locking screw, two bushings, and two connector cover assemblies from front of RF case (fig. FO-8, view C).

g. Replacement of RXMT/AUDIO and XMODE Connector Cover Assemblies. Assemble loop of cover assembly lanyard between two bushings and assemble to RT case with screw (fig. FO-8, view C).

h. Remove and Replace Binding Post Rubber Cover.

2-7. Repair

Repair of the radio set is limited to replacement of entire components.

2-8. Testing After Repair

a. General. The operational checks provide verification of proper functioning of the RT unit after repair. They also provide the means for exercising all modes of operation during troubleshooting to identify the failed equipment. Perform all the operational checks, following the procedural steps in the order given, and set all controls accurately.

NOTE

The following operational checks assume all required ancillary equipment is available for all operating modes.

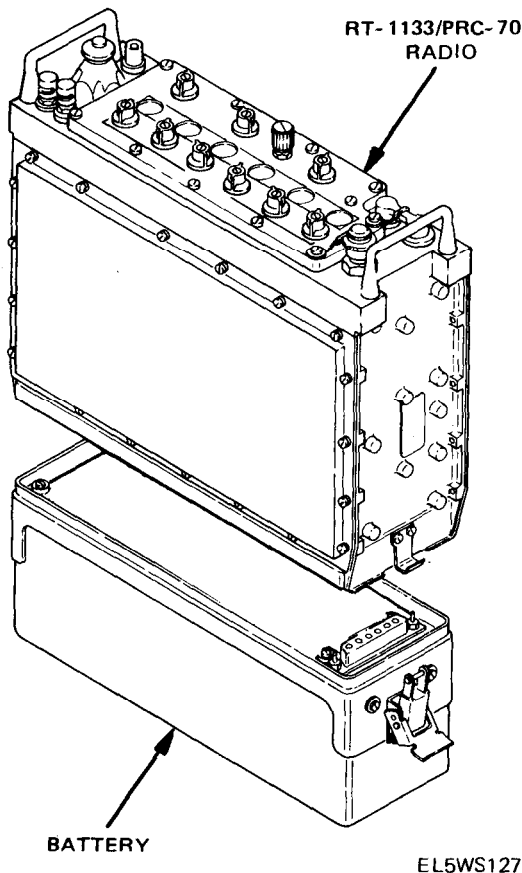

Figure 2-1. RT unit battery connection.

b. Operational Checks.

- (1) Assemble RT unit and battery assembly.
- (2) Install radio set in portable configuration.

WARNING

When operating in HI PWR with the whip antenna, do not touch the antenna when in transmit mode; an RF burn can result.

- (3) Operate the RT unit in all modes, and verify the operating characteristics of each at different operating frequencies. (See TM 11-5820-553-10 for operating instructions.)

(a) Voice (AM, SSB or FM)

1. To transmit in any voice mode, key the push-to-talk switch on the Handset H-250A/U, and speak into the microphone.

2. To receive in any voice mode, release the PTT switch and listen.

(b) CW and FSK.

1. To transmit, key the RT unit with the Keyer KY-116/U.

2. To receive, release the key and listen with the Headset H-251/U.

- (4) Install radio set in each fixed configuration.

- (5) Repeat paragraph 2-8b(3) for each fixed configuration.

- (6) Set RT unit POWER switch to OFF.

CHAPTER 3

FUNCTIONING OF EQUIPMENT

Section I. RECEIVER-TRANSMITTER FUNCTIONAL ANALYSIS

3-1. General

This section contains the functional theory for Receiver-Transmitter RT-1133/PRC-70 (hereafter referred to as the RT unit). Functional theory for the RT unit subassemblies is given in section II of this chapter. The information in this chapter is provided to aid in troubleshooting the RT unit.

3-2. Simplified Block Diagram Analysis
(fig. FO-1)

a. Receive Path. The received RF signal (2 to 76 MHz) enters the RT unit through the WHIP, WIRE, or ANT connector. The RF signal passes through the coupler module 1A1A24 to the detector module 1A1A27. (The detector module develops the primary control signal for the coupler module.) From the detector module, the signal is switched by the receive/transmit relays K1 and K2 and applied to the 2 to 76 MHz bandpass filter 1A1FL1. After the bandpass filter, the signal is applied to the upconverter module 1A1A13 where it is converted to the first intermediate frequency of 111.455 MHz. The local oscillator required for this conversion (and for subsequent frequency conversion) is provided by the pump VFO module 1A1A18. The first IF selectivity module 1A1A14 and the first IF AGC and gain module 1A1A15 follow the upconverter to provide gain and selectivity to the first IF signal. The signal is converted to the second IF of 11.455 MHz in the second mixer module 1A1A16. The second IF module 1A1A17 follows the mixer to provide additional gain. The signal is then converted to the third IF (455 kHz) in the mixer of the IF selectivity module 1A1A19. (A group of switched filters follow the third mixer. Selectivity provided by these filters depends on the mode selected.) The 455 kHz signal is routed through the 455 kHz IF gain module 1A1A3 to the 455 kHz IF detector module 1A1A22. Audio content of this 455 kHz signal is detected in the 455 kHz IF detector module before being applied to the audio module 1A1A23. The signal is amplified in the audio output stage, which provides the audio for the AUDIO, X-MODE, and RXMT connectors of the RT unit.

b. Transmit Mode. Voice, burst CW, burst FSK, or cipher audio signals are inputs to the RT unit through the AUDIO, RXMT, and X-MODE connectors. In the standard CW and FSK modes, keying signals are applied to the AUDIO connector. In the SSB, CW, FSK, and AM transmit modes, a 455 kHz signal from the modulator/squelch module 1A1A21 is sent to the IF selectivity module 1A1A19 to be mixed with an 11 MHz signal to generate the sum frequency of 11.455 MHz. In the FM transmit mode, an 11 MHz FM modulated signal and a 455 kHz signal from the oscillator distributor module 1A1A10 are applied to the IF selectivity module to generate the sum frequency of 11.455 MHz. From this point, the SSB, AM, CW, FSK, and FM signals all follow the same path through the second IF module 1A1A17 to the second mixer module 1A1A16 where the signal is converted to 111.455 MHz. This 111.455 MHz is routed through the first IF AGC and gain module 1A1A15 and the first IF selectivity module 1A1A14 to the upconverter module 1A1A13. The upconverter converts the signal to the operating frequency (2-76 MHz) and outputs it to the transmit broadband module 1A1A12 through the bandpass filter 1A1FL1 and receive/transmit relays K1 and K2. In the transmit broadband module, the signal is amplified to a level of 80 milliwatts. This level is maintained by the automatic gain control (AGC) loop. This signal is then amplified in the power amplifier and driver module 1A1A29 to a level of approximately 3.0 watts (LO PWR) or to a level of approximately 40 watts (HI PWR) before being applied to the harmonic filter. From the harmonic filter, the signal is routed through the detector module 1A1A27, coupler module 1A1A24, and the wire, whip, or doublet antenna.

3-3. Detailed Block Diagram Analysis

Figure FO-2 is an overall detailed block diagram analysis of the RT unit. For individual block diagram analysis, refer to section III of this chapter.

Section II. SUBASSEMBLY FUNCTIONAL ANALYSIS

3-4. Frequency Selector 1A1A1
(fig. FO-3)

The main purpose of the frequency selector module is to provide the necessary data to the other modules within the RT unit. This data contains information pertaining to the power mode, type of modulation, squelch mode, transmitter keying, operating frequency, and antenna coupler bands as selected by the operator through the front panel switches. Data signals for the power mode, modulation, squelch, and most keying functions are directly controlled by the front panel switches. The front panel utilizes a microcomputer for control of the frequency related functions. The computer transmits the data in serial data format. The computer also computes the frequency band information used by the antenna coupler and controls the bandswitch motor. In addition, the computer inhibits transmitter keying in FM mode when operating frequency below 30 MHz is selected.

3-5. Power and TR Relay 1A1A2
(fig. 3-1)

The power and TR relay 1A1A2 provides control voltages to various modules within the RT unit.

- a. Relay K1 provides ground (in receive) or -5V (in transmit) to the coupler 1A1A24.
- b. Relay K2 provides ground (in receive) or +10V and +24V switched (in transmit) to RT unit.
- c. Relay 1A1K1 provides -5V and +5V for the RT switching lines (RT-55 and TR-55).
- d. Microswitch S1 provides an AGC DISABLE signal in the operate mode, and +10V in the test mode for servicing of the RT unit.
- e. Fuse F1 provides 15 ampere protection for 24V line (in transmit) of RT unit.
- f. Fuse F2 provides 4 ampere protection (in receive) to RT unit.
- g. Diode CR3 provides reverse polarity protection at battery terminals of RT unit.
- h. Zener diode CR4 provides high voltage protection at battery input terminals of RT unit.

3-6. 455 kHz IF Gain 1A1A3 (fig. 3-2)

The 455 kHz IF gain module provides a controlled amount of gain for the receive 455 kHz IF input signal. The 455 kHz IF signal from the IF selectivity module 1A1A19 is amplified, filtered, and amplified again before being sent to the 455 kHz IF detector module 1A1A22.

a. *Input Amplifiers.* The first stage of amplification amplifies the IF signal 30 dB. The next stage amplifies the IF approximately 19 dB. the final

stage buffers the IF signal before it enters the ceramic filter.

b. *Ceramic Filter.* The filter allows the 455 kHz IF signal to pass with approximately 8 dB insertion loss and attenuates all other frequencies.

c. *Output Amplifiers.* After the filter, the IF enters another three stage amplifier. The first stage provides 12 dB of gain and the second provides an additional 24 dB of gain. The final stage buffers the IF signal before being sent to the 455 kHz IF detector module.

d. *Gain Control Circuits.* An AGC control voltage which is routed through the power and TR relay module is processed by the gain control circuit. The gain circuits control the bias on the first amplifier stage in the input and output amplifiers. The entire IF amplifier section is capable of providing 80 dB gain; however, the gain will be less due to the action of the gain control circuits.

3-7. Power Supply +10V/+5V Regulator 1A1A4 (fig. 3-3)

This module provides +10V and +5V for analog and digital functions within the RT unit.

a. *+5V Analog/Digital.* The +24V from the -5V regulator 1A1A5 is filtered; then regulated by microcircuit U2, a single-ended switching regulator. The regulated +5V is triggered through the power switch and filtered. Filters FL1 and FL2 are the output filters for the +5V digital and +5V analog respectively.

b. *+10V Source.* The +24V from the -5V regulator 1A1A5 is filtered; then regulated by microcircuit U1, a single-ended switching regulator. The regulated +10V is triggered through the power switch and applied to filter FL3.

c. *Trigger In.* The trigger input from the -5V regulator 1A1A5 synchronizes the regulators which provide switching pulses to the power switches.

3-8. Power Supply -5V Regulator 1A1A5 (fig. 3-4)

The -5V regulator provides -5V to the various modules within the RT unit and a trigger signal for the +10V/+5V regulators.

a. *-5V Output.* The +24V from the power and TR relay 1A1A2 is transferred through relay K1 contacts to the input filter(s). (In the transmit mode, the +24V requires additional filtering.) The filtered +24V is regulated to -5V by microcircuit U1 which provides switching pulses to the power switch. The output filter provides filtering for the -5V output voltage.

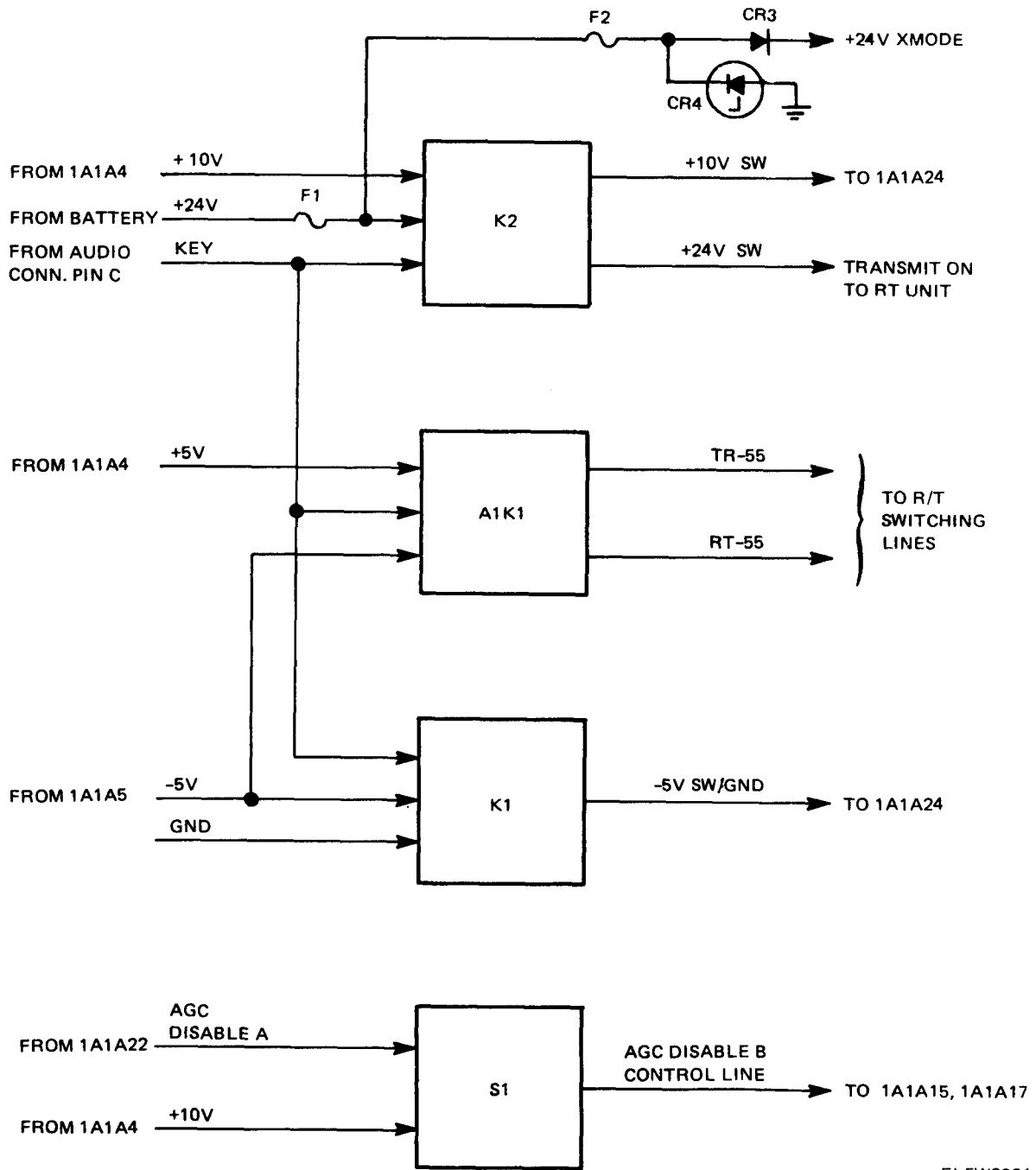

EL5WS001

Figure 3-1. Power and TR relay 1A1A2, block diagram.

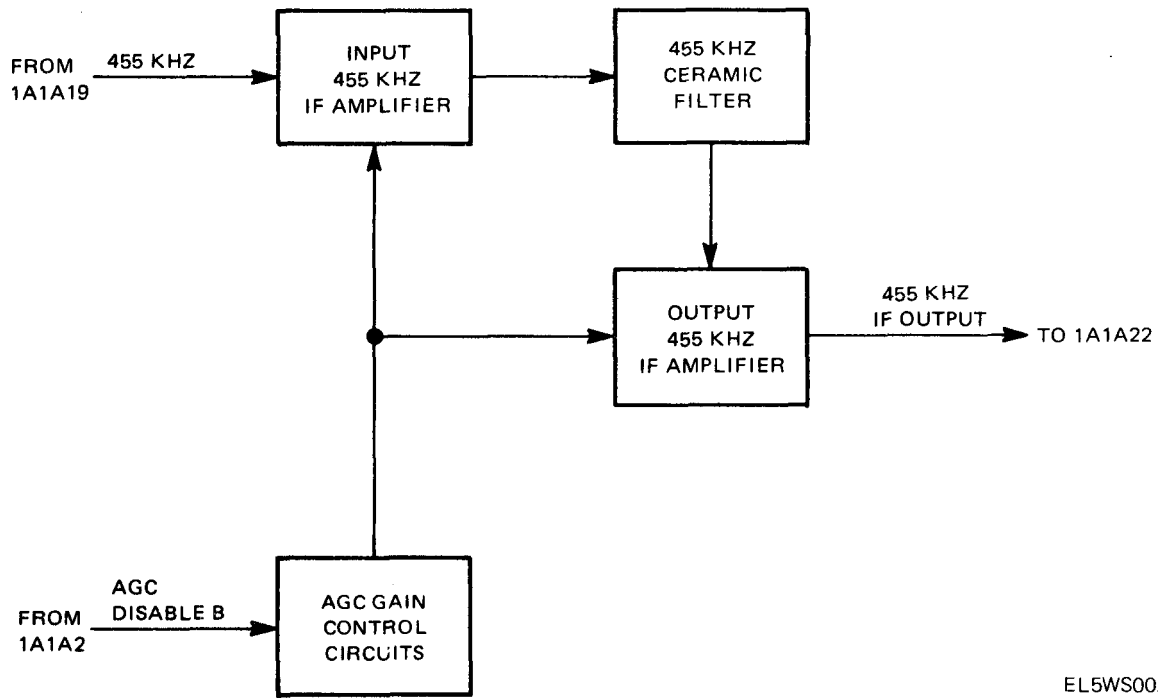

EL5WS002

Figure 3-2. 455 kHz IF gain 1A1A3, block diagram.

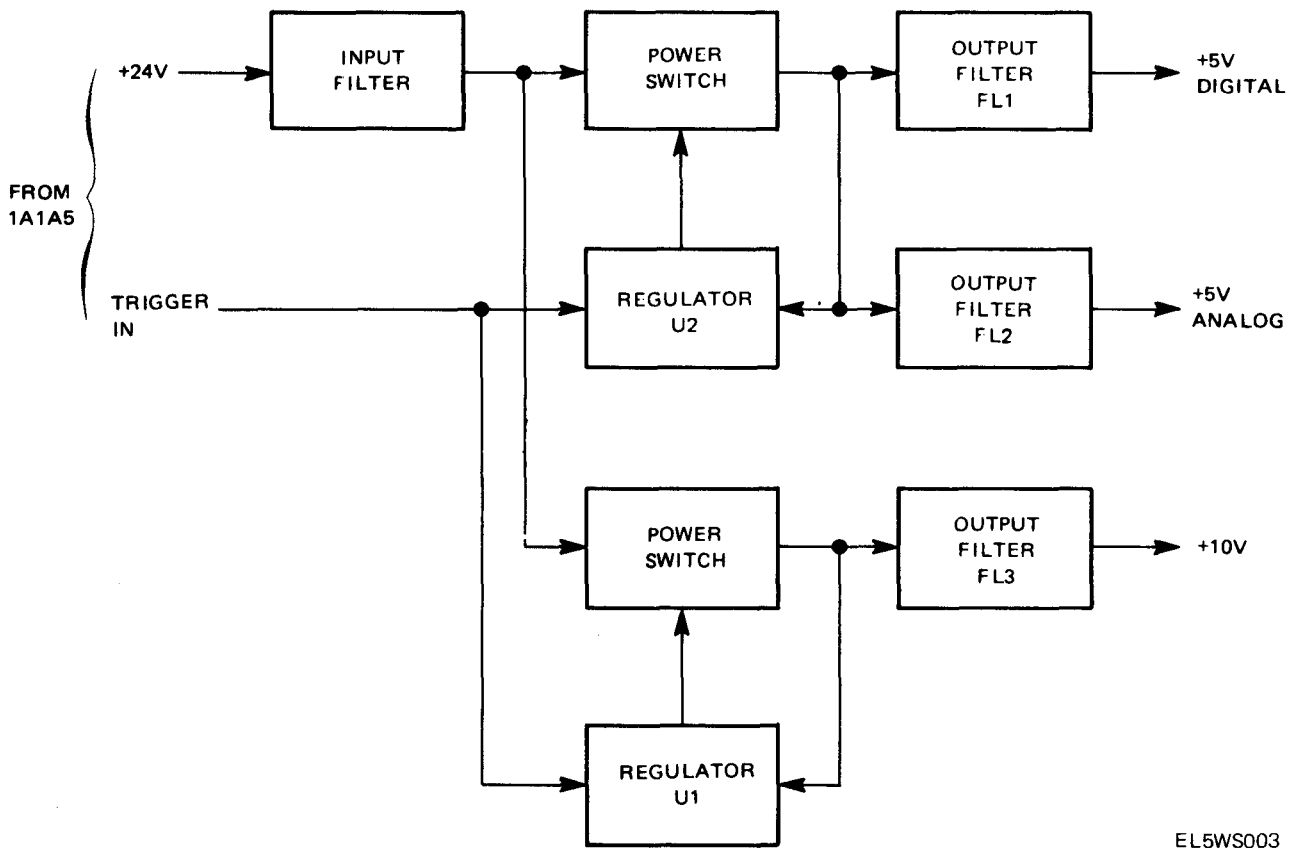

EL5WS003

Figure 3-3. Power supply +10/+5V regulator 1A1A4, block diagram.

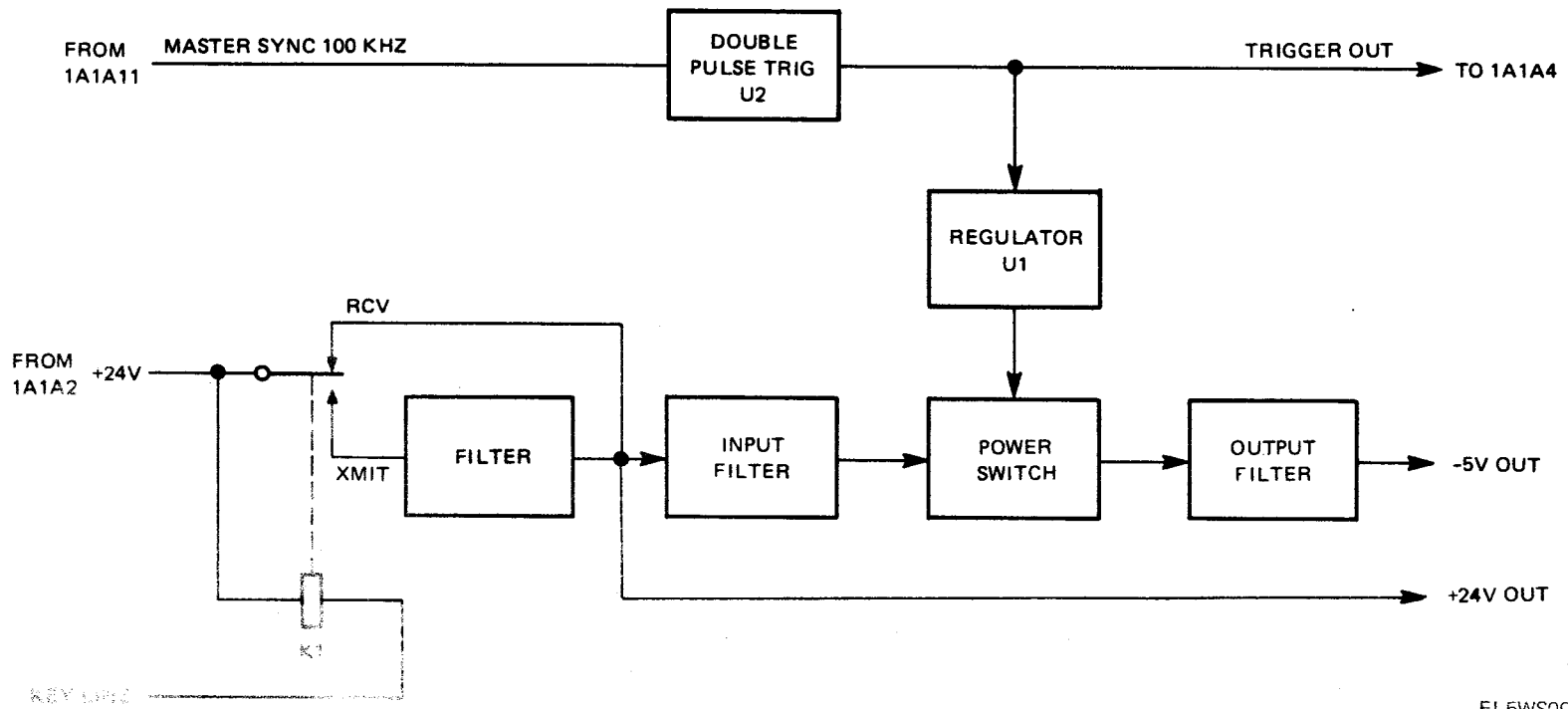

EL5WS004

Figure 3-4. Power supply -5V regulator 1A1A5, block diagram.

b. Master Sync. A 100 kHz square wave reference signal from the oscillator digital divider 1A1A11 is applied to the double pulse trigger circuit U2. This circuit converts the single pulse reference signal into two output pulses. The double-pulse trigger output provides trigger signals to the switching regulators in the +10V/+5V regulator as well as the -5V regulator.

3-9. Translator 1A1A6 (fig. 3-5)

The translator module provides the mixers, buffers and filters required to translate the synthesizer lower loop interpolations to the upper loop. The lower loop interpolations from the lower loop serial 1A1A9 are represented by a variable 4.7550 to 4.8549 MHz input to the RF mixer No. 1. Also, a 100 MHz signal from the second mixer 1A1A16 is applied to the RF mixer No. 1 through a buffer amplifier stage. The RF mixer No. 1 sum frequency output (104.7550 to 104.8549 MHz) is amplified, filtered, and then applied to another RF mixer No. 2. The high level input to this mixer is the 113.4550 to 187.4549 MHz from the pump VFO 1A1A18 (part of the upper interpolation loop). The resulting difference frequency output (8.7 to 82.6 MHz) is amplified, filtered, and then applied to the upper loop divider 1A1A7.

3-10. Upper Loop Divider 1A1A7 (fig. 3-6)

The purpose of the upper loop divider module is to divide the 8.7 to 82.6 MHz signal from the translator 1A1A6 to a 100 kHz signal. This 100 kHz signal is sent to the upper loop phase detector 1A1A8.

a. Serial to Parallel Converter. The STROBE, DATA, and CLOCK from the frequency selector 1A1A1 contain data to load the shift registers with serial data. The shift registers convert the serial input data into parallel output data for the presentable up/down counters in the variable modulus divider.

b. Variable Modulus Divider. The signal to be divided from the translator is buffered before it is applied to the programmable divider. The 100 kHz output is sent to the upper loop phase detector 1A1A8.

3-11. Upper Loop Phase Detector 1A1A8 (fig. 3-7).

The upper loop phase detector module controls the overall operation of the synthesizer loop. The upper loop phase detector module contains a digital frequency phase detector, a register and switching circuit, and an out-of-lock detector.

a. Digital Frequency Phase Detector. The 100 kHz divide by N from the upper loop divider 1A1A7 is

compared to a 100 kHz MASTER SYNC signal from the oscillator digital divider 1A1A11. A dc control error signal is developed from the integration and low-pass filter process. This control line is sent to a voltage-controlled oscillator in the pump VFO 1A1A18.

b. Register and Switching. Frequency information from the frequency selector 1A1A1 is serially applied to a shift register. The parallel outputs of the register activates a set of switches. Depending on the synthesizer frequency selected, a transistor switch is turned on which adds a coarse tune voltage to the control line.

c. Out-of-Lock Detector. When conditions are not met in the phase detector circuitry, the out-of-lock detector turns off the dc control 1A1A20, and shuts down the RT unit.

3-12. Lower Loop 1A1A9 (fig. 3-8)

The lower loop module phase locks the high frequency voltage controlled oscillator (VCO). Serialized input data is converted to parallel data and sent to a variable divider. The parallel data divides according to the front panel frequency settings. The phase detector compares the output of the variable divider to a 1 kHz reference signal. If the compared signals are identical, the VCO is phase-locked in the circuit. The phase-detector output is sent to a low-pass filter network, developing a dc voltage which is sent to the VCO to control its output frequency. The output of the VCO is sent to a fixed divide-by-10 circuit. The output signal from this stage is applied to a balanced mixer and mixed with a 4.5 MHz reference signal providing the proper frequency output. The 4.755 to 4.8549 MHz signal is buffered and sent through a bandpass filter and then out to the translator module 1A1A6.

3-13. Oscillator Distributor 1A1A10 (fig. 3-9)

The oscillator distributor module contains a phase-locked loop, a 455 kHz buffer amplifier, a CW/FSK shaper and amplifier, and a 150 Hz shaper and amplifier.

a. Phase-Locked Loop. The 11 MHz reference and the frequency modulator share the same circuitry of the phase-locked loop with the exception of the audio amplifier. Changing the phase-locked loop parameters is accomplished by FET switching from the modulator/squelch module 1A1A21.

(1) *11 MHz reference.* The phase locked loop uses a 50 kHz reference signal from the oscillator digital divider module 1A1A11 and a VCO divide by 220 circuit to obtain the 11 MHz output. When modulation is not occurring, the natural frequency

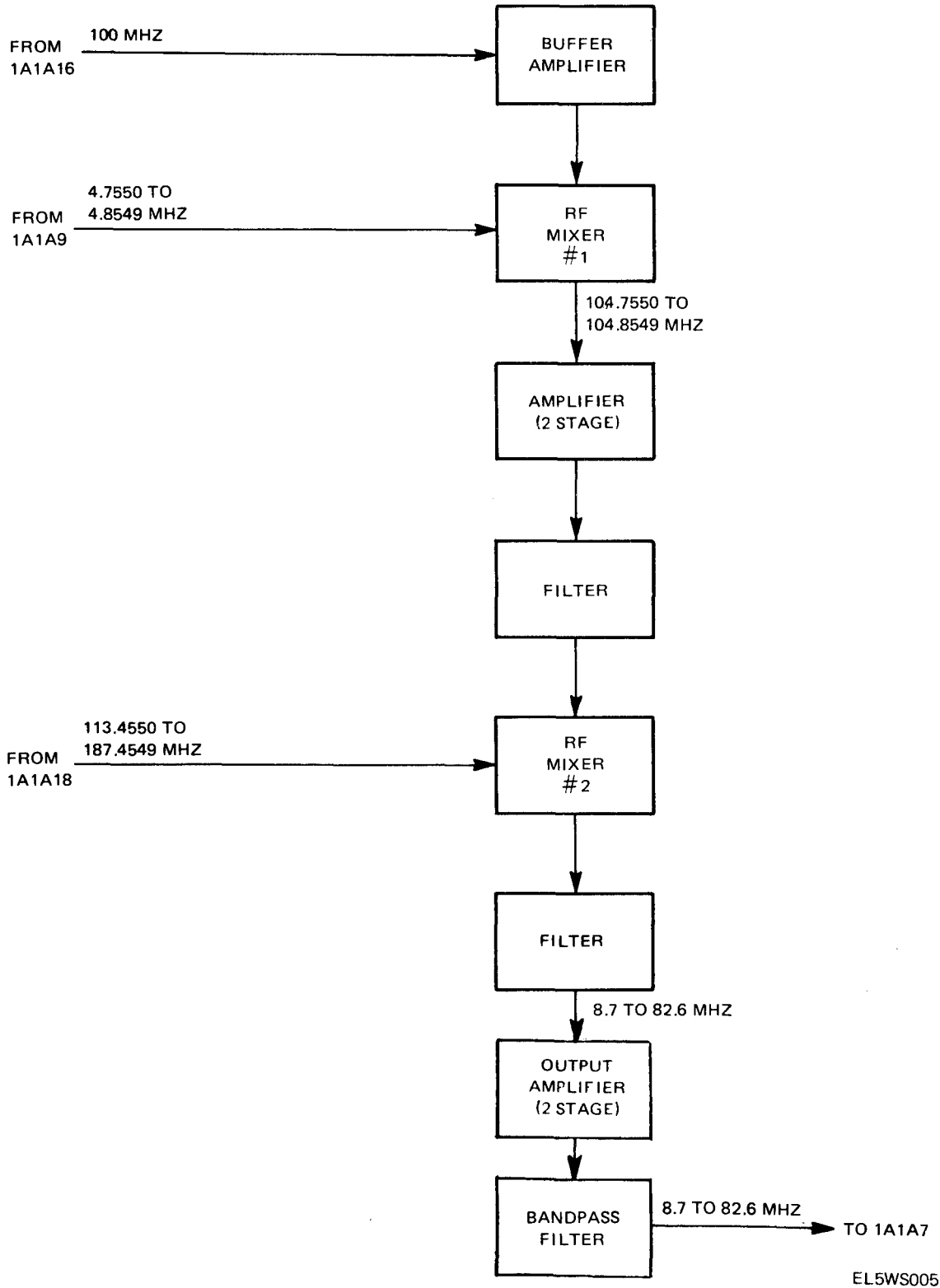

Figure 3-5. Translator 1A1A6, block diagram.

EL5WS005

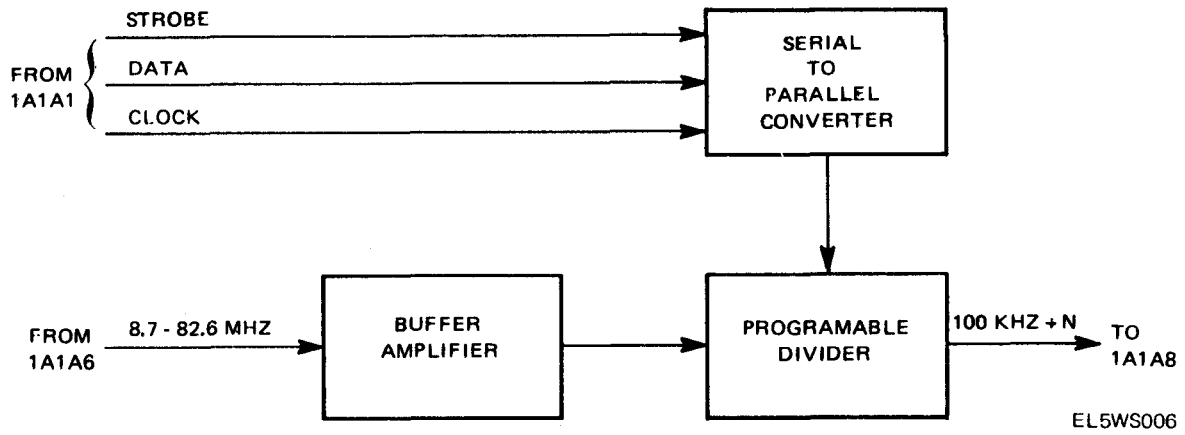

Figure 3-6. Upper loop divider 1A1A7, block diagram.

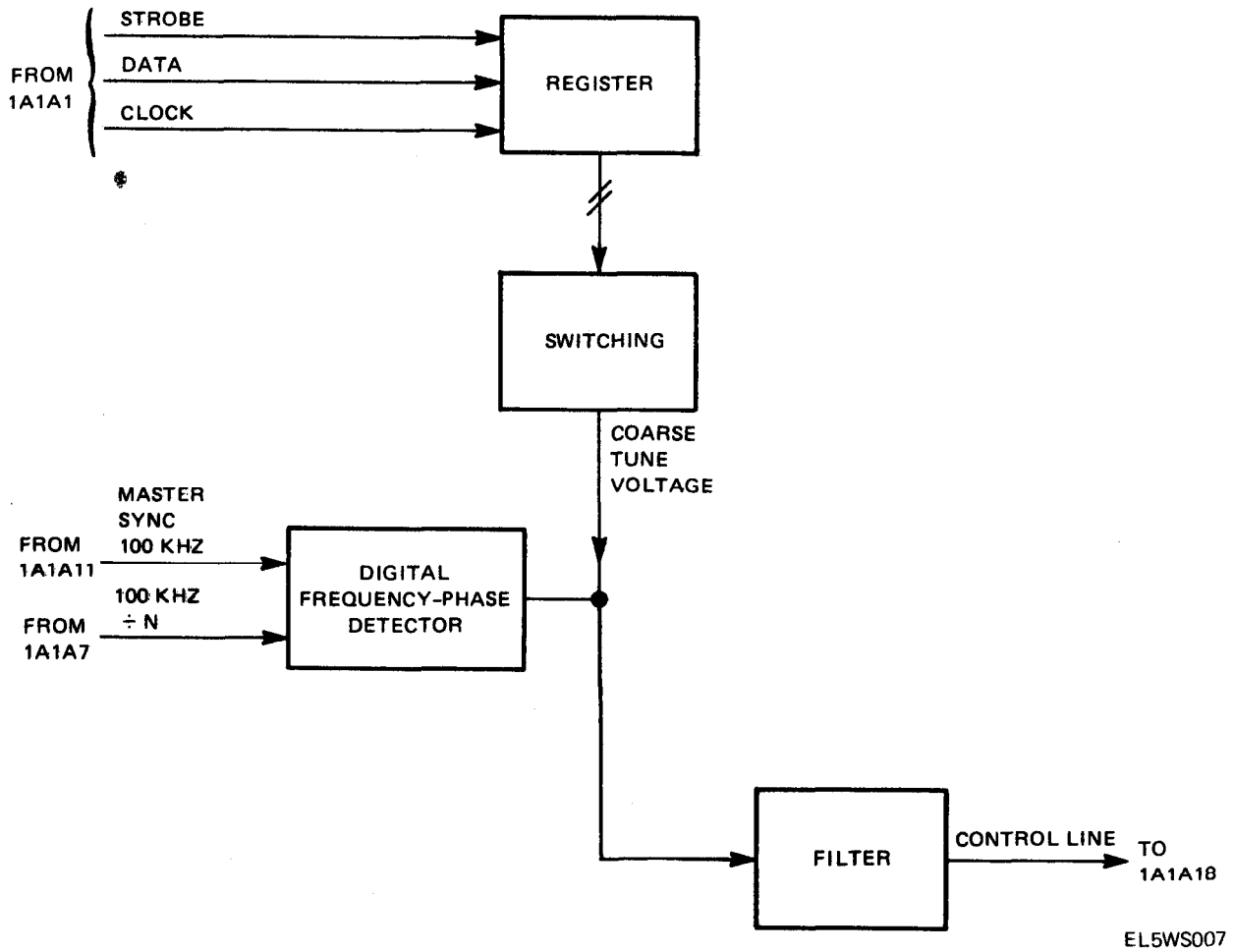
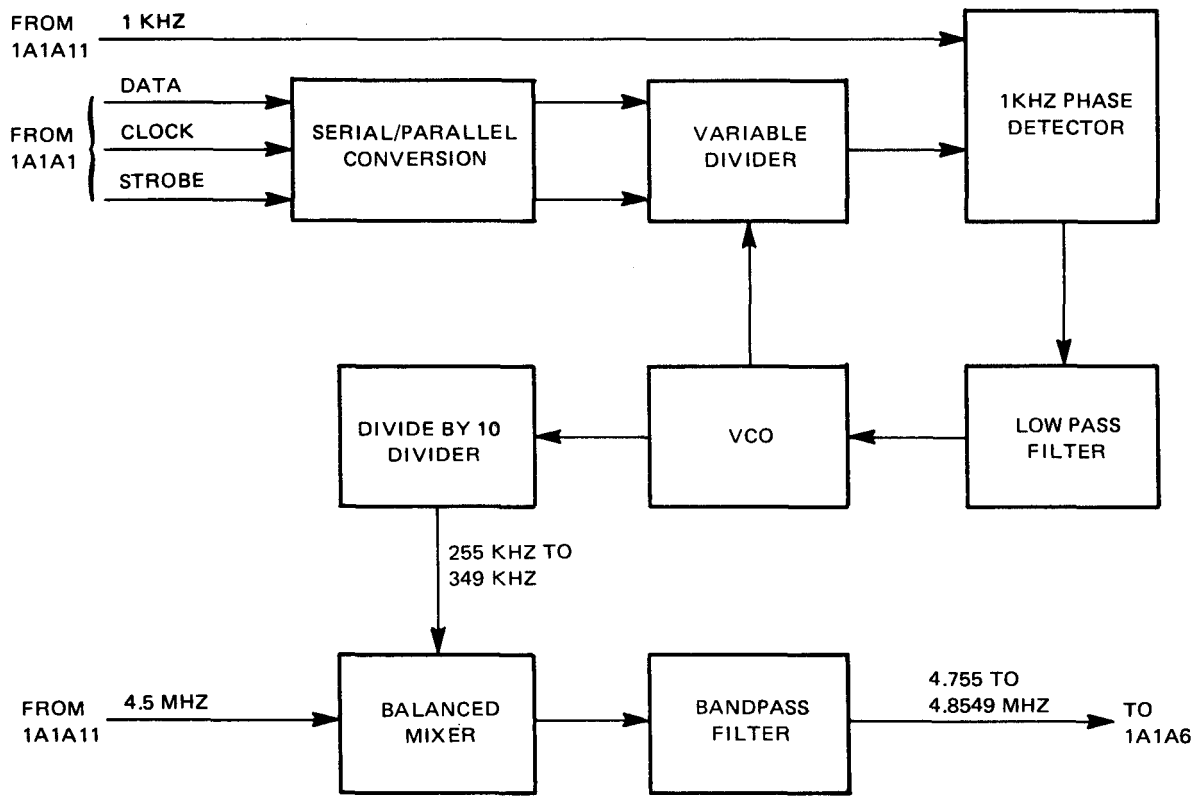
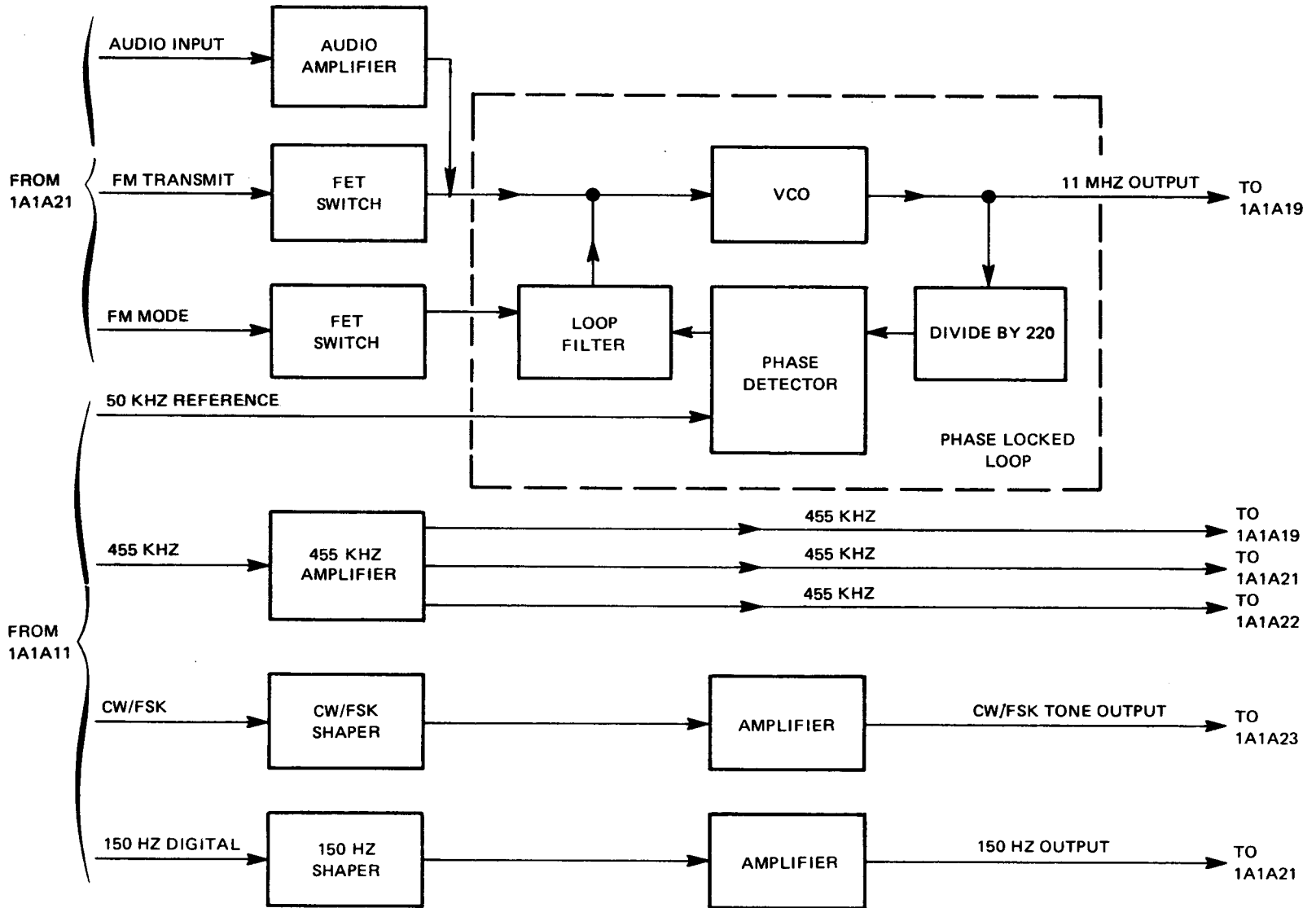

Figure 3-7. Upper loop phase detector 1A1A8, block diagram.



EL5WS008

Figure 3-8. Lower Loop 1A1A9, block diagram.



EL5WS009

Figure 3-9. Oscillator distributor 1A1A10, block diagram.

of the loop is set high (3 kHz) to produce an 11 MHz output with a low phase jitter.

(2) *Frequency modulator.* When modulating, the natural frequency of the loop is lowered (30 Hz) in order to track the audio signal from the modulator/ squelch module for modulation of the 11 MHz signal. The compensating frequency response of the audio amplifier and loop filter gives the loop an overall frequency response which is flat to 10 Hz.

b. 455 kHz Amplifier. The 455 kHz amplifier receives the 455 kHz input signal from the oscillator digital divider module. After amplification, the 455 kHz signal is distributed to three modules (1A1A19, 1A1A21, and 1A1A22).

c. CW/FSK Shaper and Amplifier. The CS/FSK shaper and amplifier receives the CW/FSK (+10V pulses) from the oscillator digital divider module. After filtering and amplification, a 32 mV rms sine wave is produced. The CW/FSK audio output is sent to the audio module 1A1A23.

d. 150 Hz Shaper and Amplifier. The 150 Hz shaper and amplifier receives the 150 Hz digital input (+10V pulses) from the oscillator digital divider module. After filtering and amplification, a 32 mV rms sine wave is produced. The 150 Hz audio output is sent to the modulation/squelch module.

3-14. Oscillator Digital Divider 1A1A11 (fig. 3-10)

This module provides 7 reference output signals that are used throughout the RT unit. It contains a temperature compensated crystal oscillator (TCXO) that generates the master reference signal. This signal is divided to the proper frequencies by the digital dividers which are controlled by 7 input signals. Depending upon which mode of operation is selected, module 1A1A11 provides reference outputs for use in the other modules in the RT unit. The 455 kHz signal is filtered and shaped to produce a sine wave, a mixed 455 kHz signal, before being sent out of the module.

3-15. Transmit Broadband 1A1A12 (fig. 3-11)

This module contains an amplifier section that amplifies the RF signal from the bandpass filter 1A1FL1. There are two stages of amplification and then the RF signal is sent to the PA and driver 1A1A29. This module also contains a AGC circuit that detects the output of the final amplifier and develops an AGC voltage that is used in the second IF 1A1A17.

3-16. Up Converter 1A1A13 (fig. 3-12)

In the receive mode, the up converter module converts the RF input frequency from the bandpass filter 1A1FL1 to the first IF frequency of 111.455 MHz. In the transmit mode, the up converter module converts the IF frequency (111.455 MHz) from the first IF selectivity to the RF output frequency (2 to 76 MHz). Since the module has bilateral circuits, only the receive circuits are discussed. The up converter module consists of four basic circuits: an input trap circuit, an RF mixer, an IF filter, and a VFO (pump) buffer amplifier. The receive mode operates identically to the transmit mode, except input and output circuits signals are reversed.

a. Input Trap Circuit. This circuit prevents the IF frequency, which could lower the gain of the receiver, from reaching the bandpass filter and passes the RF frequencies of 2 to 76 MHz to the RF mixer with no appreciable insertion loss.

b. RF Mixer. The mixer has a receiver input frequency of 2 to 76 MHz from the input trap circuit. The VFO frequency (113.455 MHz to 187.4549 MHz) is supplied to the RF mixer from the VFO (pump) buffer amplifier. The two input signals are mixed to produce the IF frequency of 111.455 MHz.

c. IF Filter. The filter forms a series tuned circuit which passes the IF frequency of 111.455 MHz and attenuates all other frequencies.

d. VCO Pump Buffer Amplifier. The VCO pump buffer amplifier amplifies the input signal (113.4550 to 187.4549 MHz) and buffers this signal before being sent to the RF mixer as the VFO frequency.

3-17. First IF Selectivity 1A1A14 (fig. 3-13)

The first IF selectivity 1A1A14 is used in both receive and transmit modes of operation. The voltages from power and TR relay 1A1A2 control the function of the receive and transmit switching circuits.

a. Receive Mode. In the receive mode, the 111.455 MHz input from the upconverter 1A1A13 is amplified in two stages. After amplification, the signal is filtered in the 111.455 MHz crystal filter and then sent to the first IF AGC and gain 1A1A15.

b. Transmit Mode. In the transmit mode, the receive circuitry is biased off by the action of the transistor switch. The transmit input to the module is the 111.455 MHz signal from the first IF AGC and gain module. This IF signal is filtered in the crystal filter then routed through the diode switching circuit to the upconverter 1A1A13.

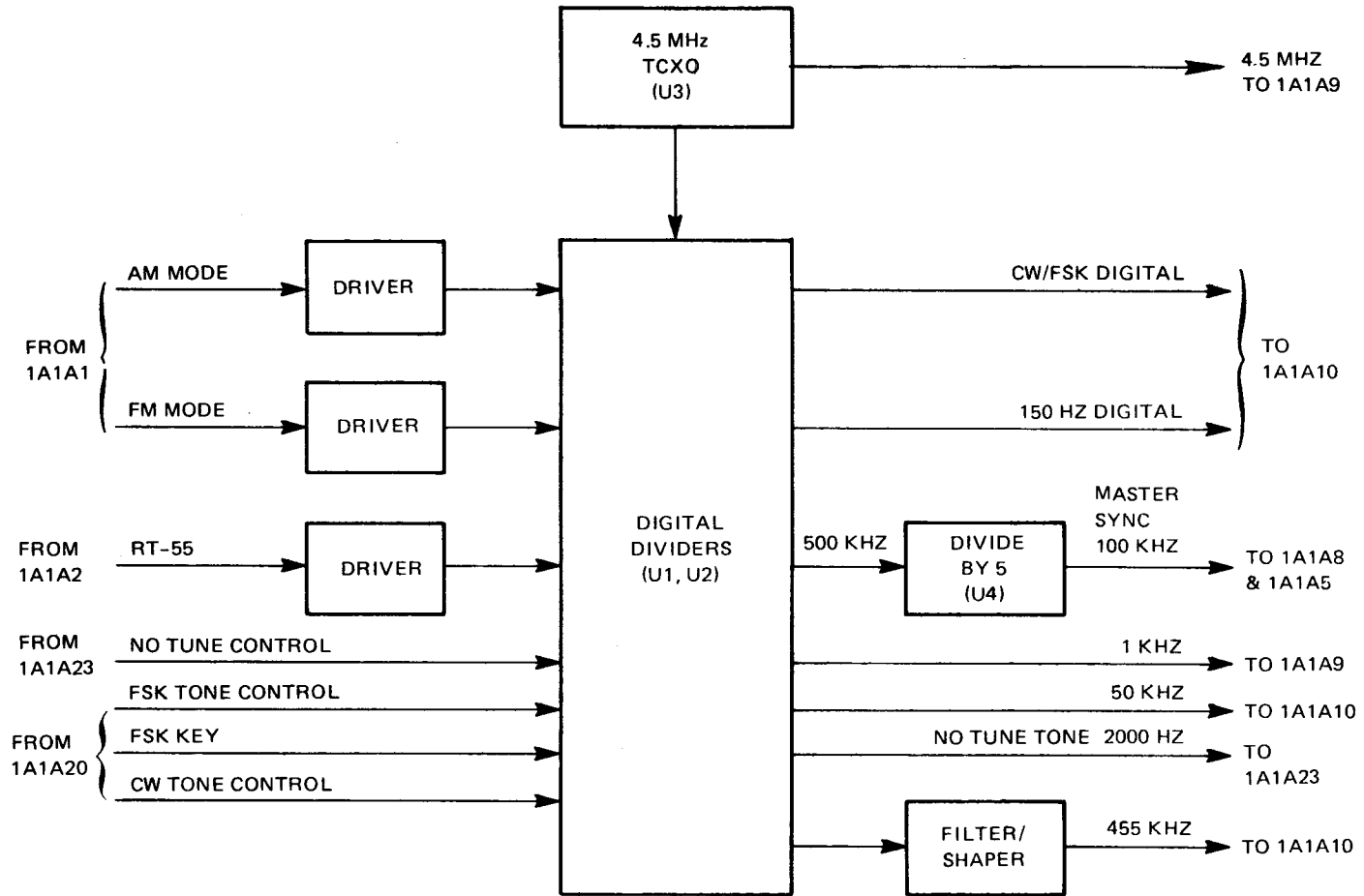

EL5WS010

Figure 3-10. Oscillator digital divider 1A1A11, block diagram.

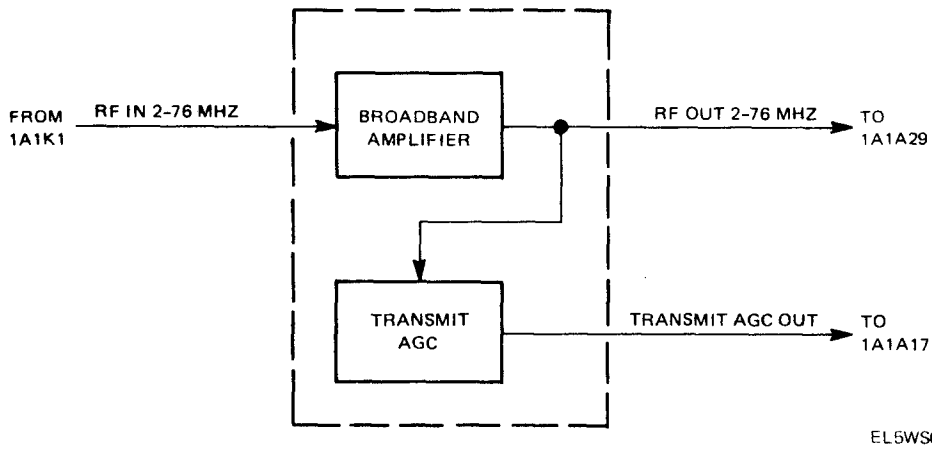

Figure 3-11. Transmit broadband 1A1A12, block diagram.

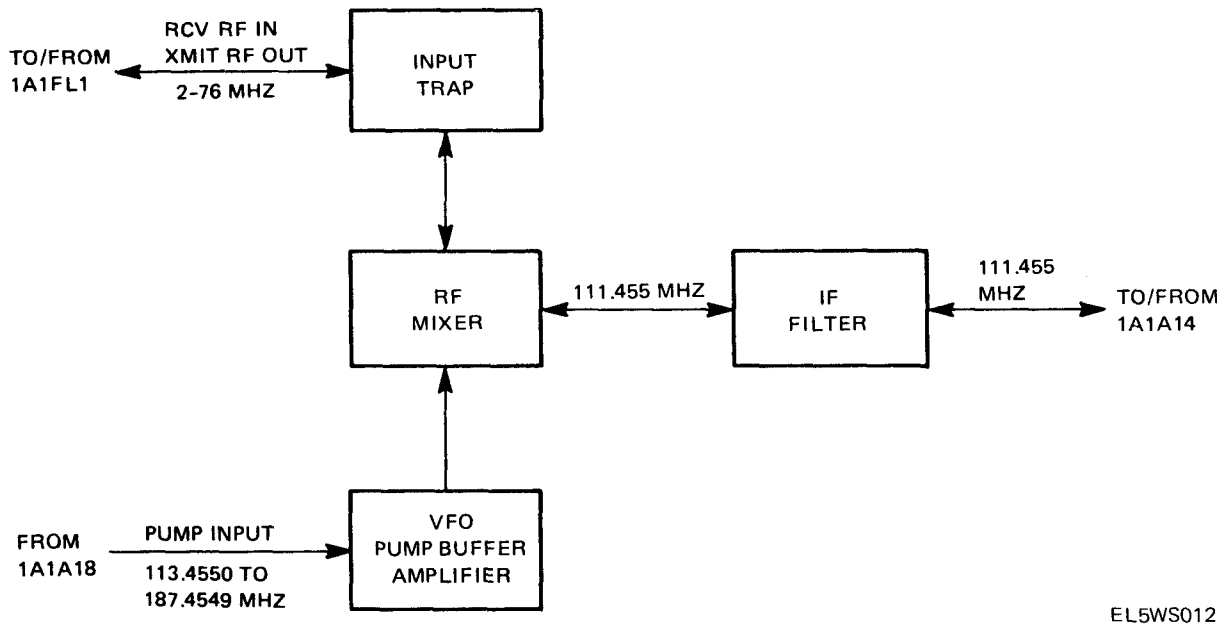
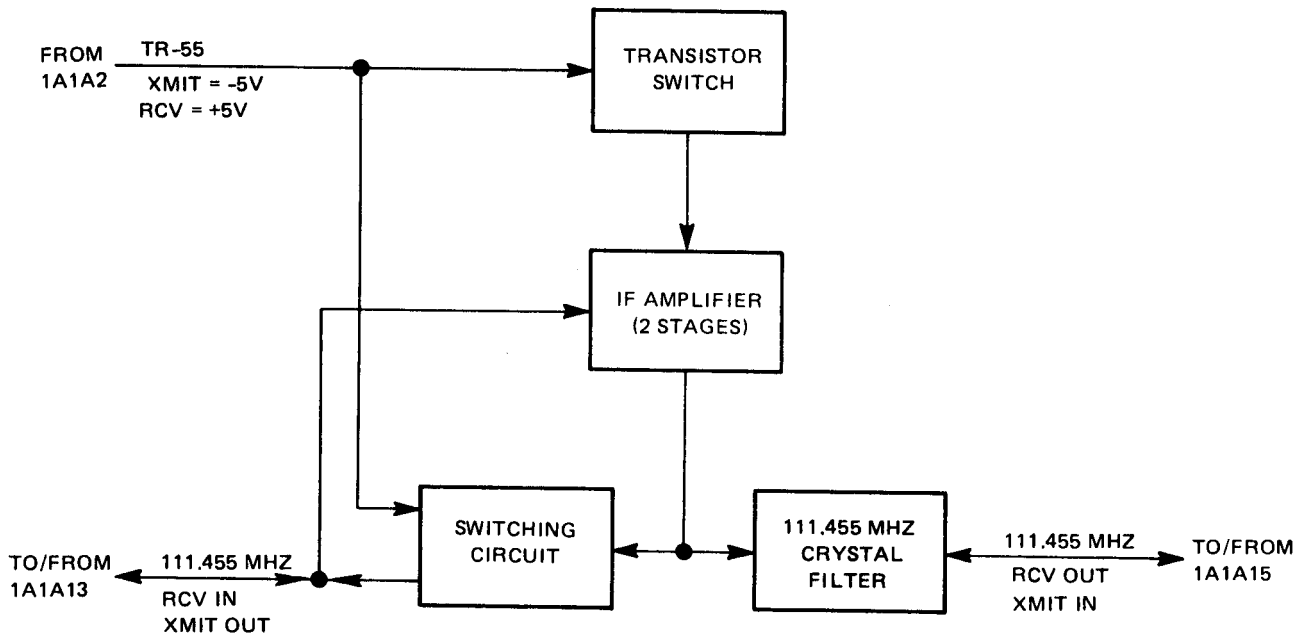

Figure 3-12. Up converter 1A1A13, block diagram.



EL5WS013

Figure 3-13. First IF selectivity 1A1A14, block diagram.

3-18. First IF AGC and Gain 1A1A15 (fig. 3-14)

The first IF AGC and gain 1A1A15 is used in both receive and transmit modes of operation. The voltages from the power and TR relay 1A1A2 control the function of the receive and transmit switching circuits.

a. Receive Mode. In the receive mode, the 111.455 MHz IF signal from the first IF selectivity 1A1A14 passes through the circuits of the receive input switching and the input amplifier whose gain is controlled by the AGC amplifier. The IF signal is further amplified in the output amplifier before being sent to the second mixer 1A1A16 (via the receive output RT switching circuit).

b. Transmit Mode. In the transmit mode, the 111.455 MHz IF signal from the second mixer 1A1A16 passes through the transmit switching circuit to the input amplifier. The IF signal is further amplified in the output amplifier before being sent to the first IF selectivity 1A1A14.

3-19. Second Mixer 1A1A16 (fig. 3-15)

The second mixer module generates outputs of 100 MHz and either 11.455 (receive) or 111.455 MHz (transmit) depending on the mode of operation. A crystal oscillator generates the 100 MHz signal which is split into two 100 MHz outputs in the hybrid power divider. One output is buffered and applied to the balanced mixer, and the other to the translator module 1A1A6.

a. Receive Mode. During the receive mode, the 111.455 MHz IF input from first IF AGC and gain 1A1A15 passes through the balanced mixer along with the 100 MHz input from the oscillator. The resulting 11.455 MHz difference frequency is passed through a crystal filter before being sent to the second IF 1A1A17.

b. Transmit Mode. During the transmit mode, the 11.455 MHz signal from the second IF module passes through the crystal filter to the balanced mixer. The combination of the 100 MHz input from the oscillator and the 11.455 MHz signal produce the 111.455 MHz frequency which is sent to the first IF AGC and gain module.

3-20. Second IF 1A1A17 (fig. 3-16)

The second IF module is used in both receive and transmit modes of operation. The voltages from the power and TR relay module 1A1A2 control the function of the receive and transmit switching circuits.

a. Receive Mode. During the receive mode, the 11.455 MHz IF signal from the second mixer 1A1A16 passes through the receive input switching circuit to the receive IF automatic gain con-

trolled amplifiers (3 stages). After amplification, the IF signal passes through the receive output switching circuit to the IF selectivity 1A1A19.

b. Transmit Mode. During the transmit mode, the 11.455 MHz (IF) signal from the IF selectivity module passes through the transmit input switching circuit to the transmit IF automatic gain-controlled amplifiers (3 stages). When the RT unit is in the CW mode, the second IF transmit amplifier is keyed on and off by the keyer. After amplification, the IF signal passes through the transmit output switching circuit to the second mixer module.

3-21. Pump VFO 1A1A18 (fig. 3-17)

The pump VFO module generates the 113.4550 to 187.4549 MHz frequency for two modules (translator 1A1A6 and upconverter 1A1A13). The control line from the upper loop phase detector is filtered and applied to a single voltage controlled oscillator (VCO). Utilizing two tuning varactors, the oscillator generates the 113.4550 to 187.4549 MHz frequency range. This output is coupled to two separate buffer amplifiers before being sent to the translator module and the upconverter module.

3-22. IF Selectivity 1A1A19 (fig. 3-18)

The IF selectivity module develops the 455 kHz receive IF and the 11.455 MHz transmit IF. This module also provides selectivity for the 455 kHz IF by the use of switched filters and an FM pad. Dependent upon the mode involved, FET switches accomplish the required signal routing through the IF selectivity module.

a. Balanced Mixer and Buffer Circuits. The balanced mixer and buffer circuits operate in all modes. An 11 MHz input from the oscillator distributor 1A1A10 is applied to the balanced mixer through a buffer stage. In the receive mode, the mixer receives an 11.455 MHz input from the second IF 1A1A17 and produces a difference frequency output of 455 kHz. In the transmit mode (except FM), a 455 kHz signal from the modulator/squelch 1A1A21 is applied to the balanced mixer to generate the sum frequency output of 11.455 MHz to the second IF module. In the FM transmit mode, an 11 MHz FM modulated signal and a 455 kHz signal from the oscillator distributor module are applied to the balanced mixer to generate the sum frequency of 11.455 MHz.

b. Receive Mode. Operation of the IF selectivity module in all the receive modes is essentially the same. The 455 kHz IF signal from the balanced mixer is routed through an enabled FET switch (AM + TUNE) and applied to three FET input

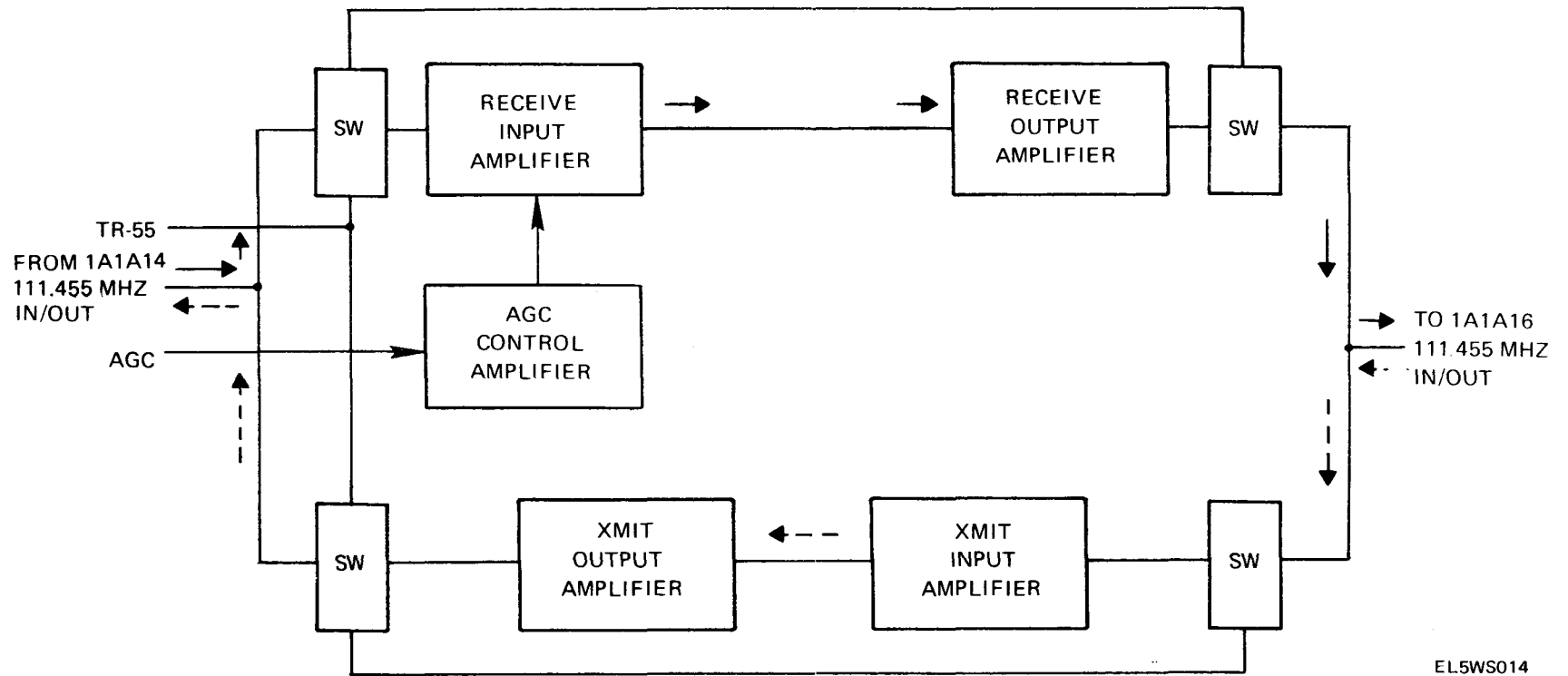

EL5WS014

Figure 3-14. First IF AGC and gain 1A1A15, block diagram.

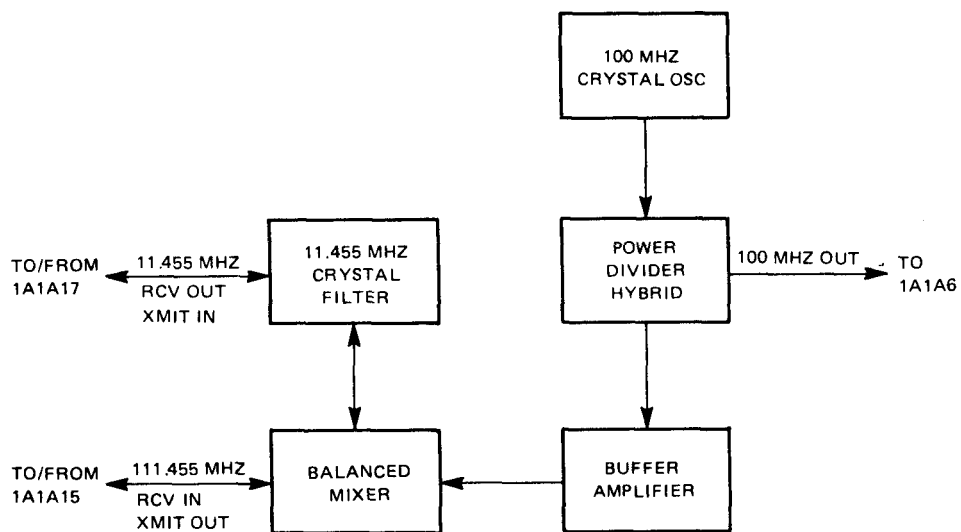

EL5WS015

Figure 3-15. Second mixer 1A1A16, block diagram.

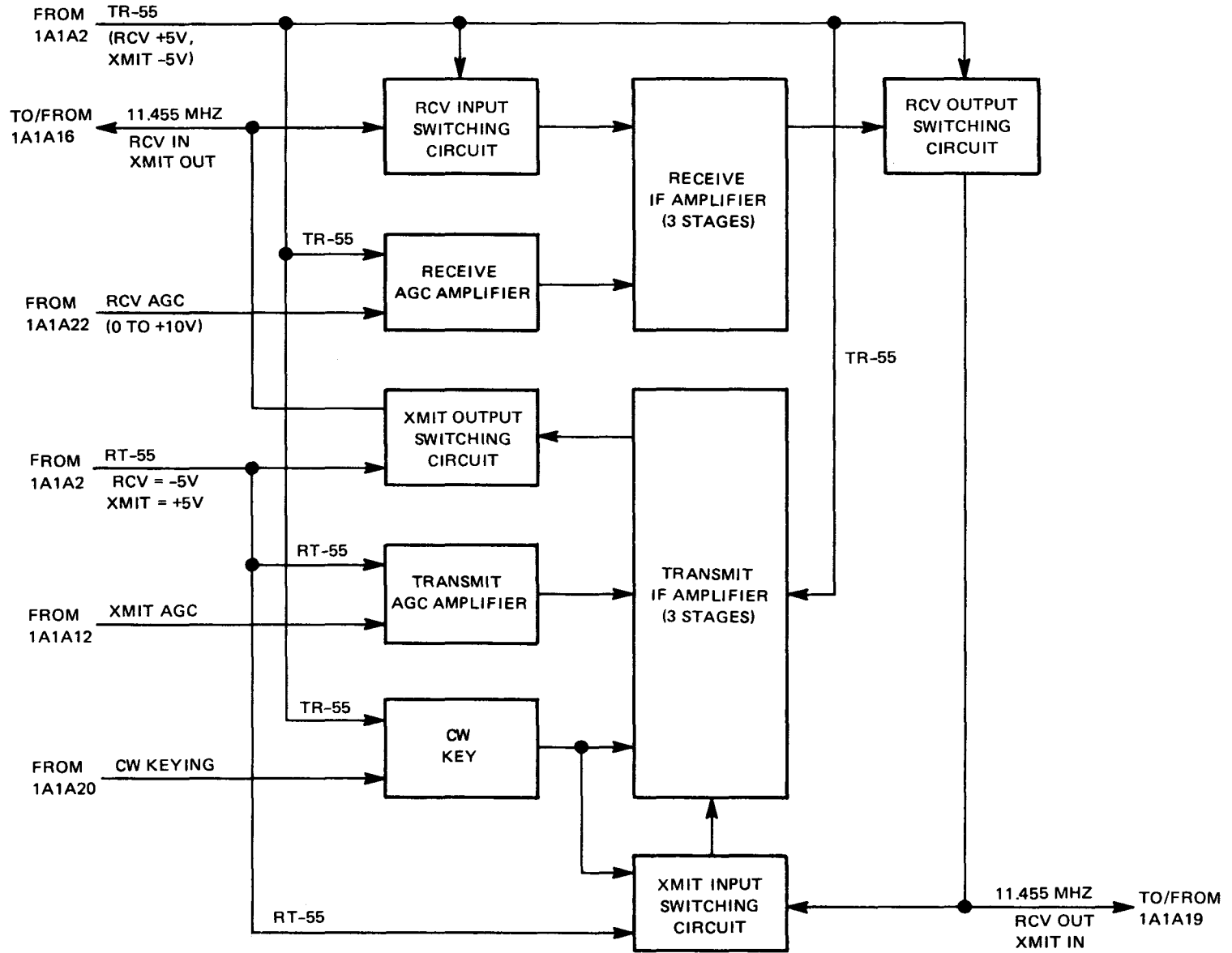

EL5WS016

Figure 3-16. Second IF 1A1A17, block diagram.

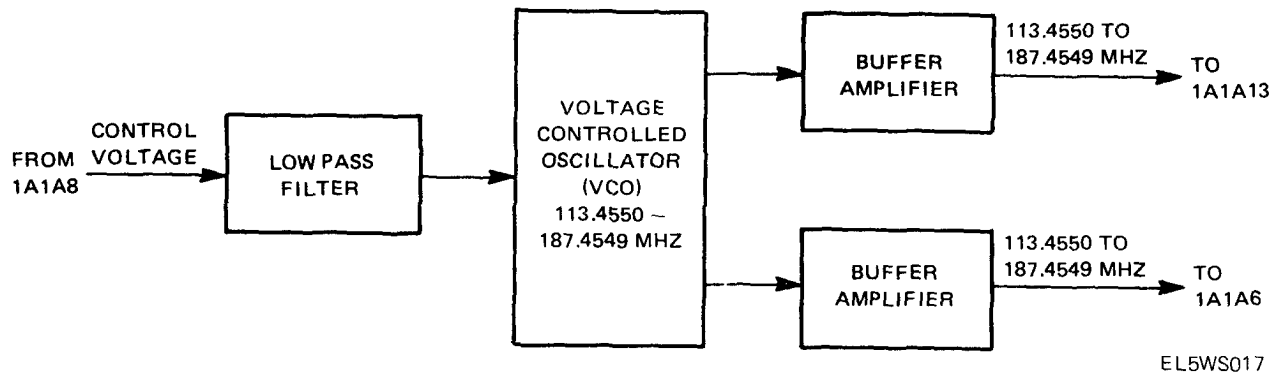

Figure 3-17. Pump VFO 1A1A8, block diagram.

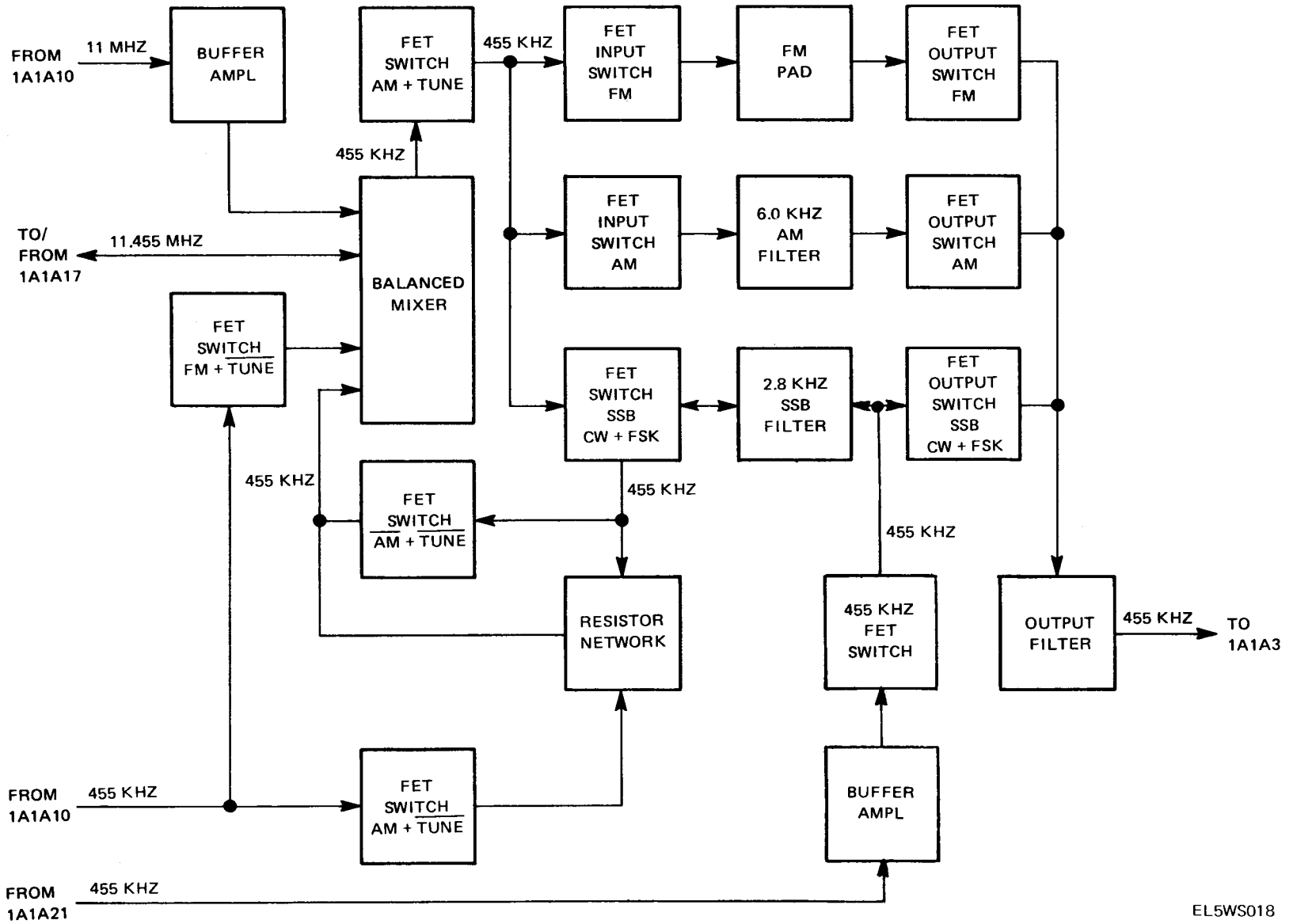

Figure 3-18. IF selectivity 1A1A19, block diagram.

EL5WS018

(filter) switches. One of these switches will be enabled, depending on the operating mode selected. The 455 kHz signal is then routed through either a 2.8 kHz SSB filter, a 6.0 kHz AM filter, or an FM pad and another series of FET switches. The output is finally sent to an output filter before being applied to the 455 kHz IF gain 1A1A3.

c. Transmit Mode. The FM transmit mode was previously discussed in the balanced mixer explanation. The following explanation will be in the AM, SSB, CW, and FSK transmit modes.

(1) *SSB, CW, and FSK transmit modes.* In the SSB, CW, and FSK transmit modes, a 455 kHz signal from the modulator/squelch module is routed through a buffer amplifier and an FET switch to the 2.8 kHz SSB filter. The filter removes the lower sideband, producing a SSB output. From the filter, the signal is routed through FET switches (SSB + CW + FSK and AM + TUNE) to the balanced mixer.

(2) *AM transmit mode.* In the AM transmit mode, the 455 kHz, SSB signal is developed in the same manner as above. However, the signal is mixed with a 455 kHz carrier signal in the resistor network preceding the balanced mixer. The resulting AM signal consists of a carrier and one sideband (upper sideband only). This signal is applied to the balanced mixer along with the 11 MHz signal to generate the 11.455 MHz output to the second IF module.

3-23. DC Control 1A1A20 (fig. 3-19)

This module provides transmitter keying and controls signals for CW, FSK, and retransmit (RXMT) modes of operation, and it provides a regulated dc voltage for the frequency selector.

a. Hold Circuit. The hold circuit provides a 1.35 ± 0.4 second-hold signal to keep the transmitter keyed during pauses.

b. Gates. The gates provide routing and timing functions for the module outputs. Outputs are dependent on input combinations.

(1) FSK TONE - requires PTT and FSK mode inputs.

(2) CW TONE - requires PTT and CW mode or TUNE inputs.

(3) KEY - requires PTT or TUNE inputs.

(4) FSK KEY - occurs whenever the RT unit is keyed.

(5) CW KEY - requires PTT and CW MODE or TUNE, or OUT-OF-LOCK input.

(6) RXMT KEY - requires RXMT MODE and SQUELCH inputs.

c. +12V Regulator. The voltage regulator provides a +12V output that is switched in the frequency selector for external use.

3-24. Modulator Squelch 1A1A21 (fig. 3-20)

This module provides a squelch signal in the receive mode, and amplifies and/or modulates the audio signal in the transmit mode.

a. Receive Mode. In this mode, only the squelch circuit is activated. The audio amplifier amplifies the low-pass filtered audio from 1A1A23 and applies it to the signal/noise squelch circuit. This circuit compares the signal/noise level. When the signal/noise level reaches a predetermined peak, it produces a squelch signal output to 1A1A23. The hold timer holds the receiver unsquelched for a given amount of time when the audio signal is not present.

b. Transmit Mode. The modulator section activates during the transmit mode operation.

(1) *FM.* The audio amplifier amplifies the wideband audio from 1A1A23, and the audio switch provides +10V for FM transmit.

(2) *AM, CW and FSK.* The audio switch routes narrowband audio to the balanced modulator. The balanced modulator modulates the audio signal with a 455 kHz carrier signal from the oscillator distributor 1A1A10. The modulated audio signal is amplified and sent to 1A1A19.

3-25. 455 kHz IF Detector 1A1A22 (fig. 3-21)

This module demodulates the 455 kHz IF signal to its audio component. It also develops an AGC voltage for three receive IF modules.

a. AM Detection. In the AM mode of operation, the signal is applied to an IF amplifier and then to a demodulator. The output from this stage is audio. It is applied to a buffering circuit; then to a filter to eliminate any remaining high frequency components before the audio signal is sent to the audio module 1A1A23.

b. SSB, CW, and FSK Detection. In these modes of operation, the signal is sent to an IF amplifier. It is then mixed with a 455 kHz signal to produce what is effectively an AM signal. From the mixer, the signal is demodulated, buffered, filtered, and sent to the audio module in the same manner as an AM signal.

c. FM Detection. The FM signal is first amplified and then sent to an FM discriminator where the audio is retrieved from the IF signal. The audio is then sent to the buffer and filter circuits before being sent to the audio module.

d. AGC Detector and Hold Timer. The signal first goes through three amplifier stages then enters the AGC detector. The level of AGC is adjustable and the hold timer circuitry maintains this level for a

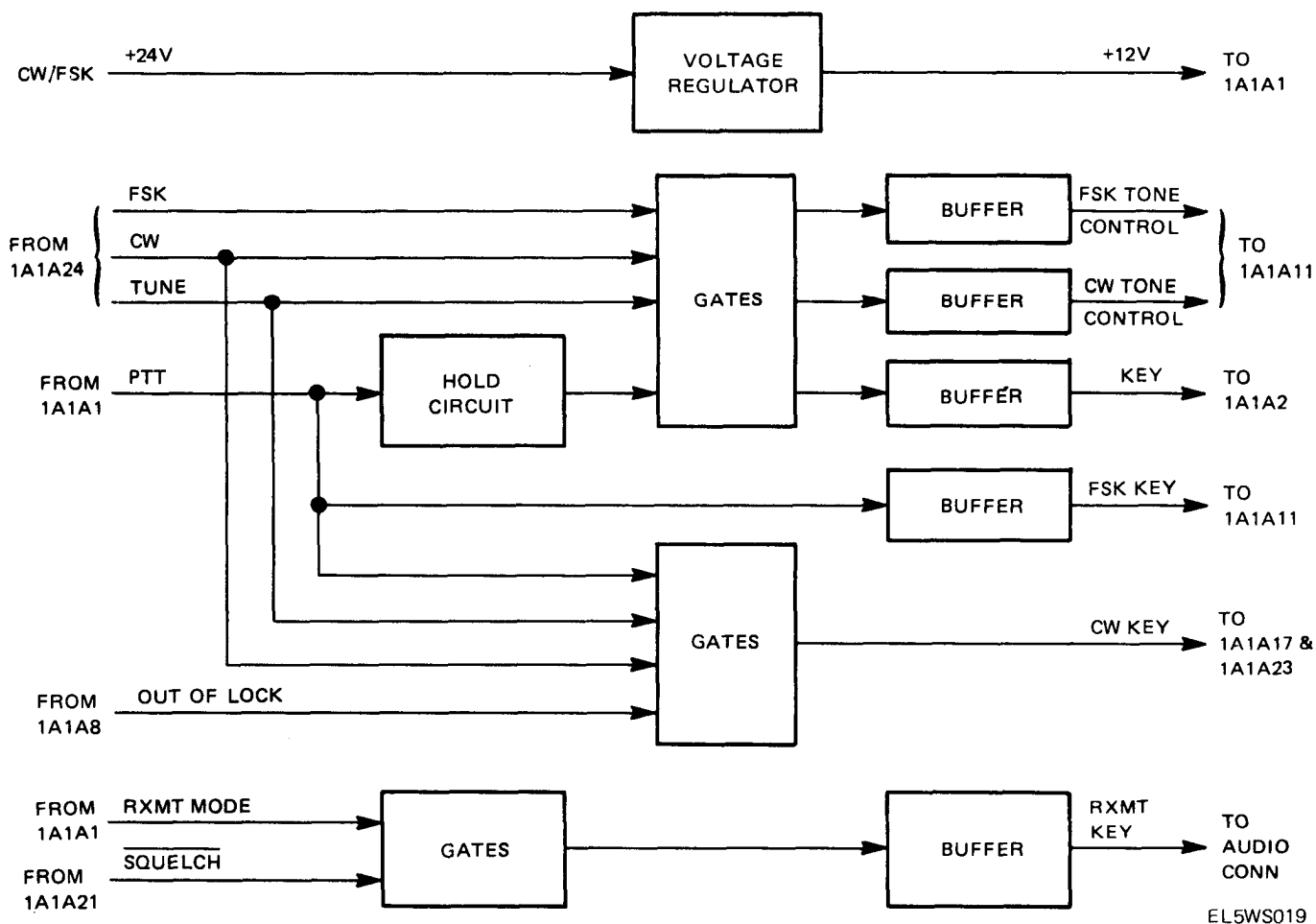

EL5WS019

Figure 3-19. DC control 1A1A20, block diagram.

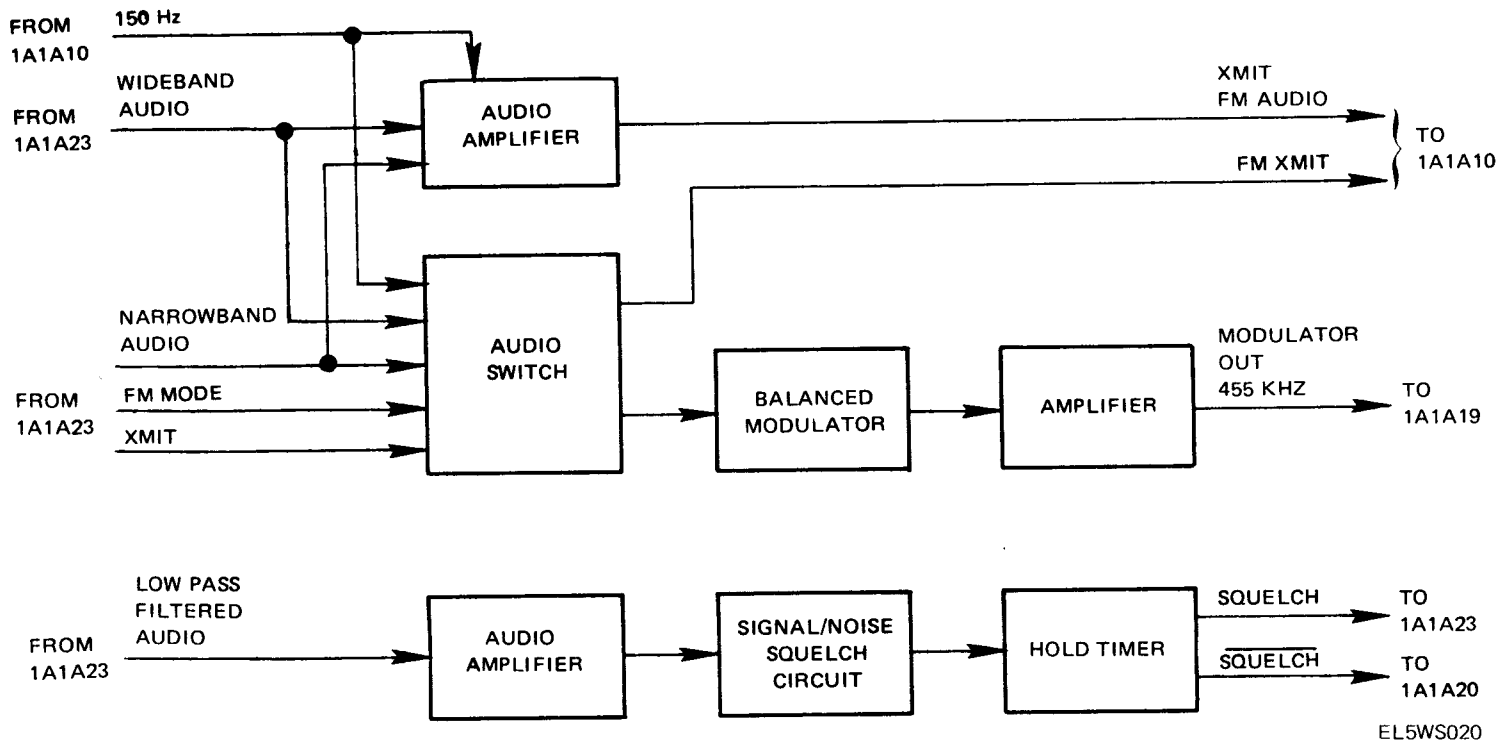
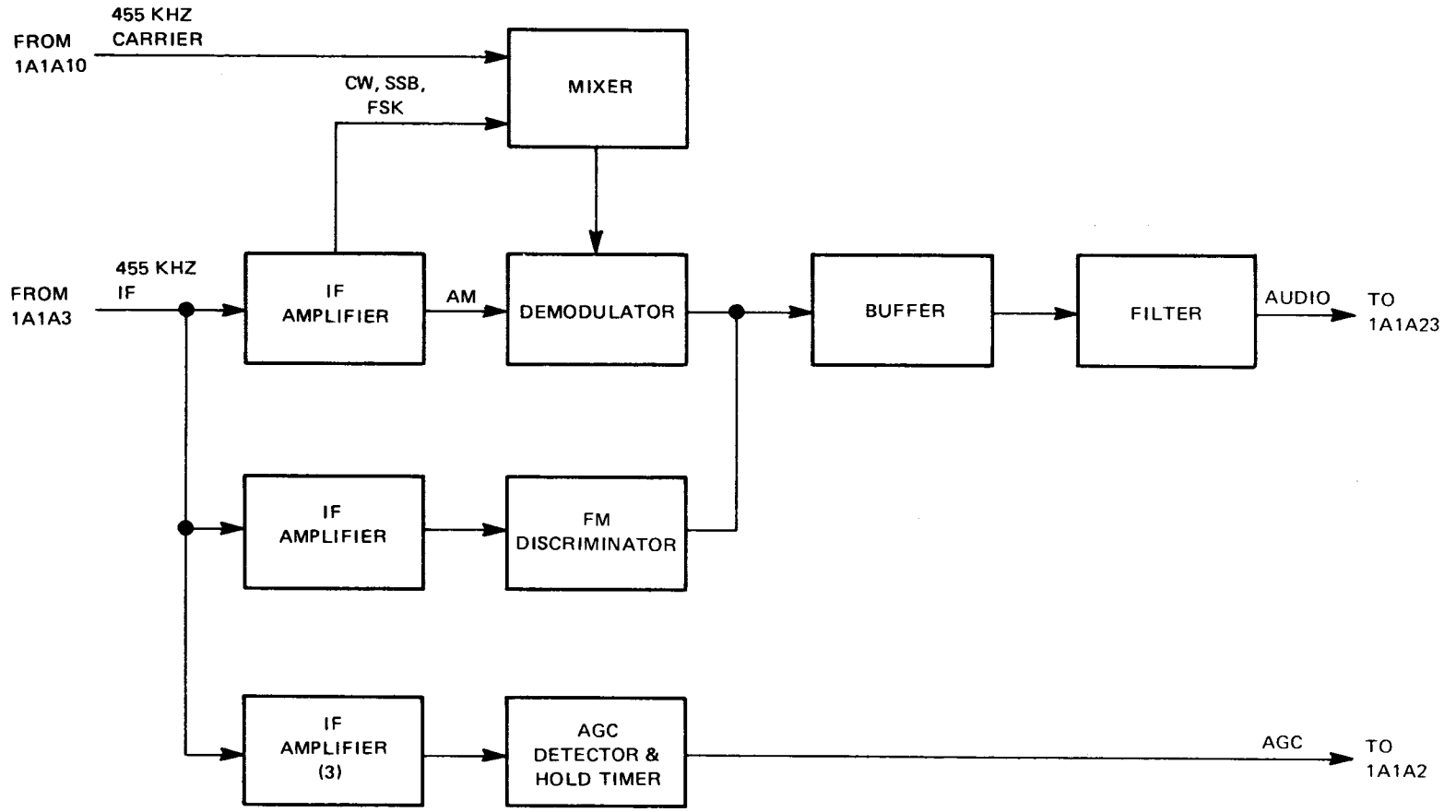

Figure 3-20. Modulator/squelch 1A1A21, block diagram.

EL5WS020



EL5WS021

Figure 3-21. 455 kHz IF detector 1A1A22, block diagram.

period of time if the incoming IF level changes abruptly.

3-26. Audio 1A1A23 (fig. 3-22)

This module amplifies audio signals in both the receive and transmit modes. In transmit, the audio is sent through an audio amplifier and then into a wideband amplifier. The signal is then utilized as a wideband audio output signal and as a low pass filter input. The low pass filter output is applied to the modulator/ squelch 1A1A21 and to the high pass filter which attenuates any signal below 500 Hz and amplifies the remaining signal. This amplified signal is sent out as narrowband audio to modulator/squelch 1A1A21 and to the volume control on the front panel. It comes back to the audio power amplifier for final amplification of the audio signal. In receive, the signal from 1A1A22 is sent through switching and into the wideband amplifier. The signal then follows the same path as in the transmit mode of operation.

3-27. Coupler 1A1A24 (fig. 3-23)

The coupler 1A1A24 maximizes the transfer of power between the transmitter and the antenna, and the received signal applied between the receiver and the antenna. The coupler network is a "T" with inductive arms (phase and resistance reactors), and shunt capacitance (capacitor switching assembly). The inductances are switched out by vacuum relays. Two of the output inductances (resistance arm) and three of the input inductances (phase arm) are saturable reactors with permanent magnets for memory. Once set, these inductor settings can be maintained without power. The shunt capacitance is bandswitched in 10 bands by means of the bandswitch motor. Two positions of the POWER switch, RCV ONLY and TUNE, affect the coupler control logic. The RCV ONLY position causes the coupler to home. The home condition exists when all switchable inductors are shorted out (minimum inductance). The TUNE position will either cause the coupler to perform a complete tune cycle or retune cycle. This depends upon whether the coupler was in home condition or previously tuned. When fully tuned the coupler tune cycle will stop. If tuning is not achieved in 15 seconds the coupler will stop the tuning cycle.

3-28. Automatic Level Control (ALC) 1A1A25 (fig. 3-24)

The ALC module generates an attenuator control signal to turn off or limit the output of the power amplifier and driver 1A1A29. Reflected and forward power indication signals from detector

1A1A27 are applied to attenuator threshold circuits. Here, the signals are combined to produce an attenuator control signal that controls a PIN diode attenuator circuit in the power amplifier and driver 1A1A29.

3-29. Bandswitch 1A1A26 (fig. 3-25)

This module contains a bandswitch and feed-through connectors to route various control signals and voltages. The bandswitch is driven by a motor that is energized any time a change of band occurs. The bandswitch controls the motor and stops the motor when circuits are properly aligned. The alignment of this switch determines the position of switches on the detector 1A1A27 and the harmonic filter 1A1A28.

3-30. Detector 1A1A27 (fig. 3-26)

In transmit mode the detector module develops the primary control signals for the coupler 1A1A24. RF power from the harmonic filter 1A1A28 is routed through four detectors (reflected power, forward power, phase, and resistance). The outputs of the reflected power and forward power detectors are routed through high/low power controlled amplifiers to the ALC 1A1A25 and coupler 1A1A24 modules. These amplifiers are switched to the proper output levels for the mode being used. The resulting forward and reflected power indication levels are applied to a ratio amplifier. The ratio amplifier compares the two input signals and develops the VSWR indication signal for the coupler logic board 1A1A24A2. The forward power indication level is also sent to the coupler logic module. The phase and resistance detectors are switched into the circuit by the tune cycle relay. The outputs of these detectors are routed through gate circuits and finally sent to the coupler logic module. These signals (+R, -R, + ϕ and - ϕ) control the pulsed reactors of the coupler during the tune cycle. A sidetone control amplifier receives an input from the forward power detector through the hi/lo power controlled amplifier and it generates a sidetone control (enable) signal to the audio 1A1A23 when sufficient forward RF power has been detected. In the receive mode of operation the incoming RF signal is coupled directly through the detector module.

3-31. Harmonic Filter 1A1A28 (fig. 3-27)

The harmonic filter provides ten channels of band-pass filtering for the RF output of the power amplifier and driver 1A1A29. It contains ten low-pass filter networks and two 10-position rotary switches for input and output switching. The switches are mechanically linked to the dc motor

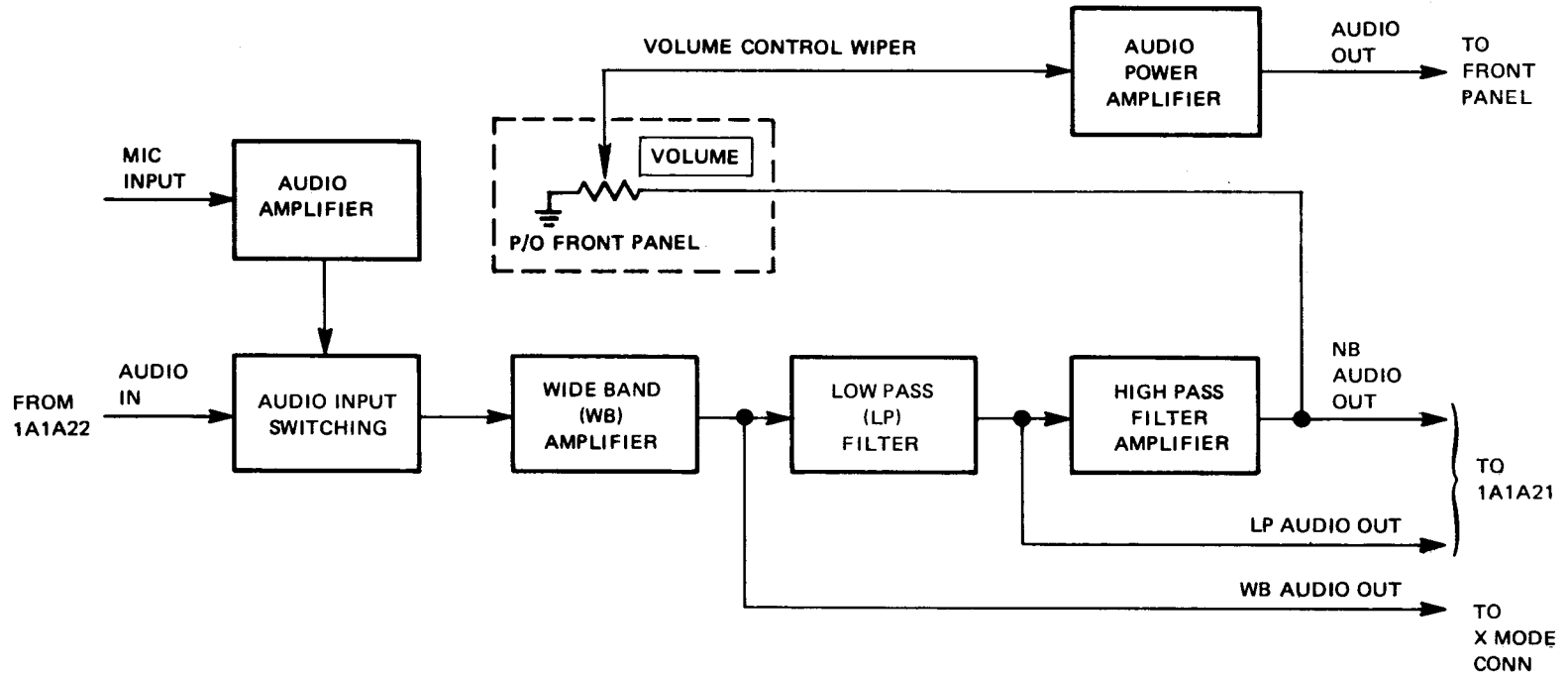

EL5WS022

Figure 3-22. Audio 1A1A23, block diagram.

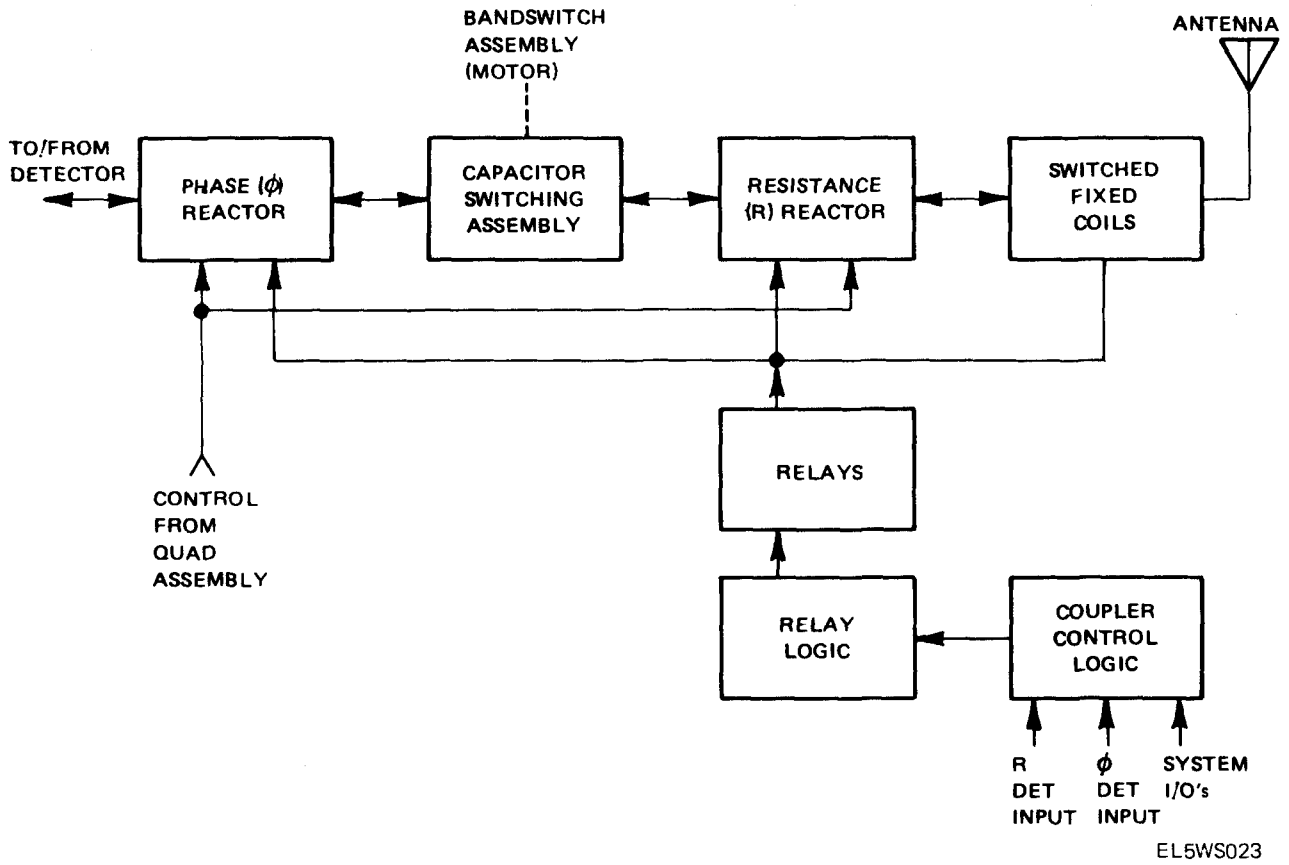

Figure 3-23. Coupler 1A1A24, block diagram.

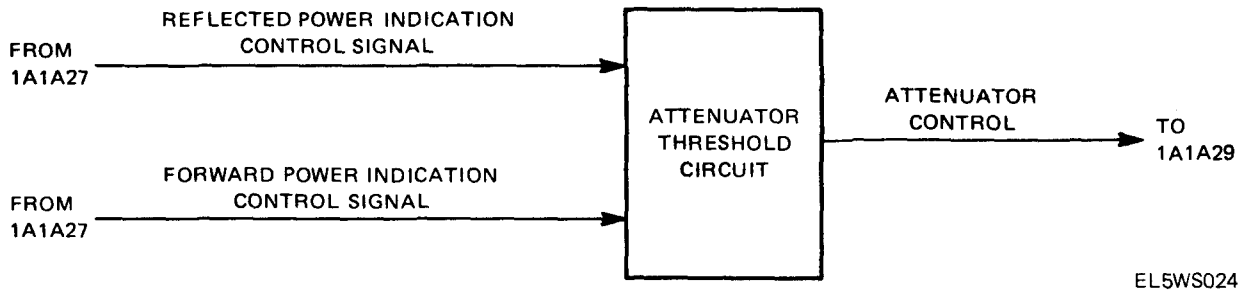
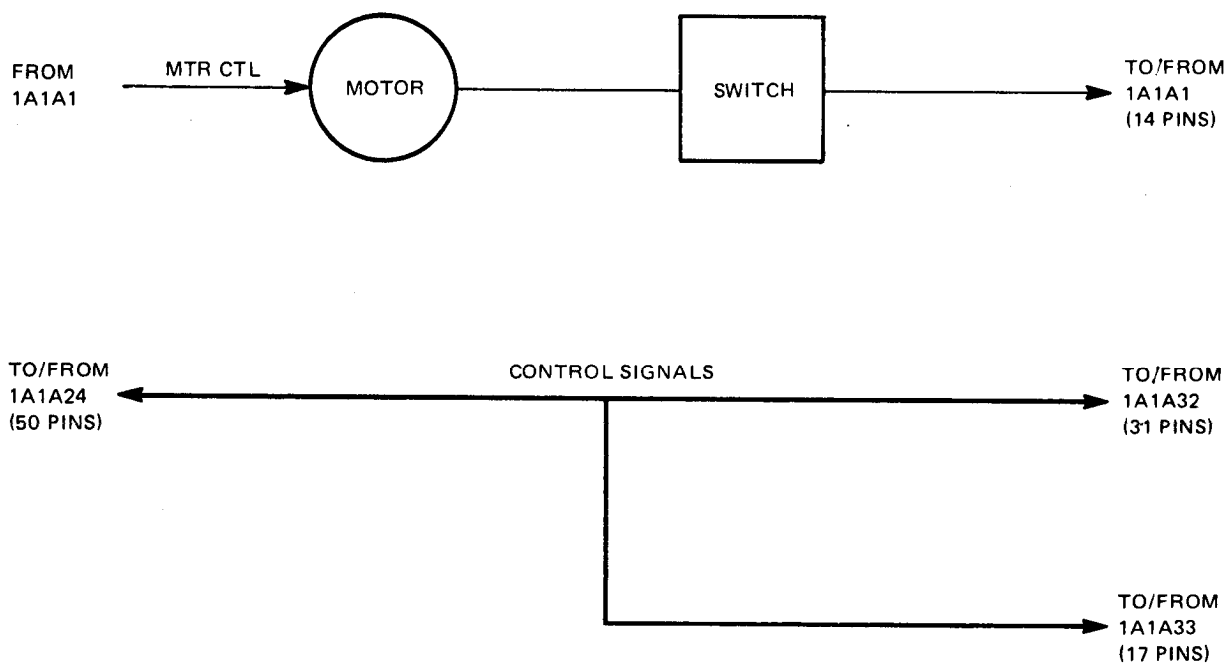

Figure 3-24. ALC 1A1A25, block diagram.



EL5WS025

Figure 3-25. Bandswitch 1A1A26, block diagram.

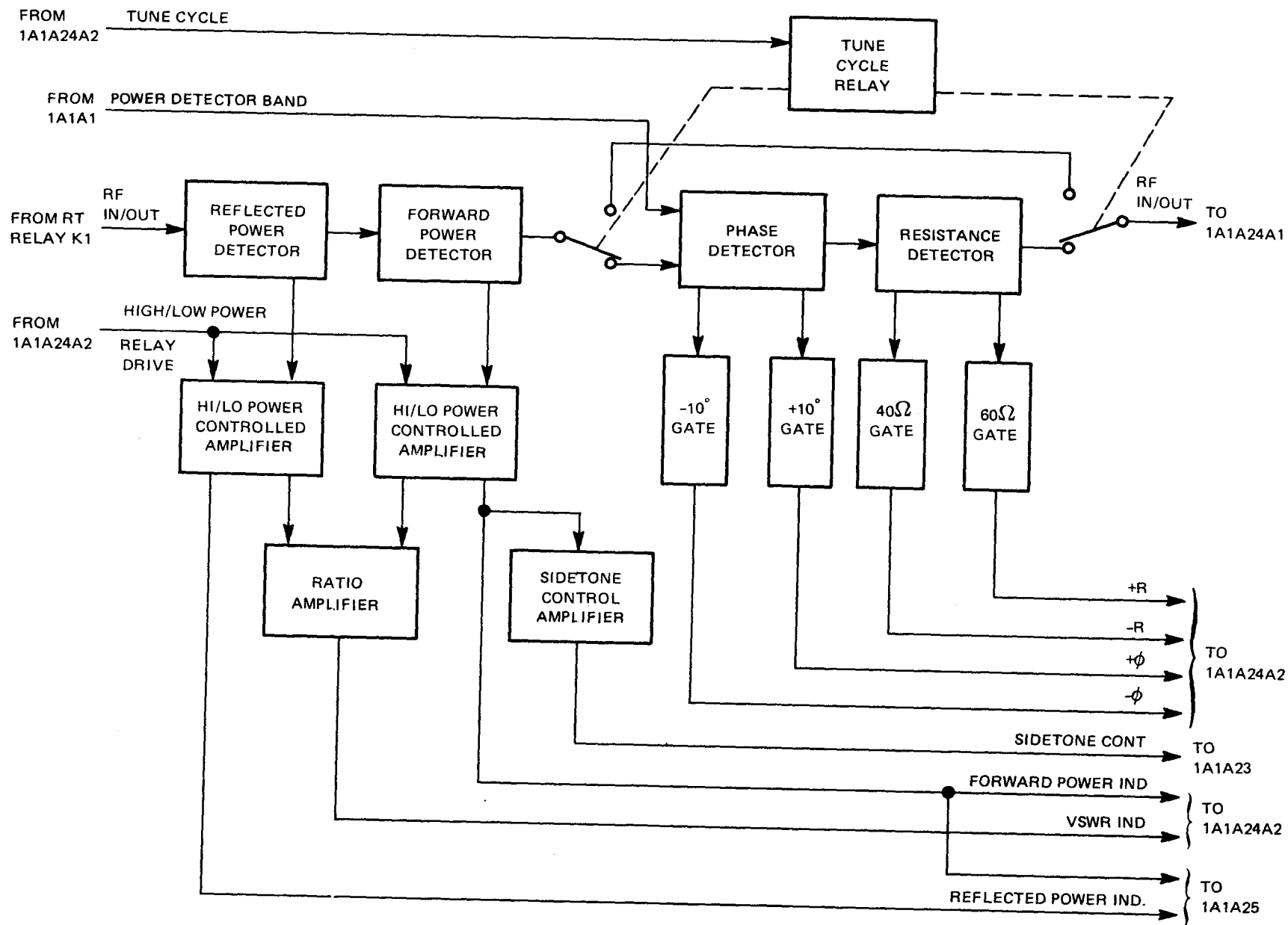

Figure 3-26. Detector 1A1A27, block diagram.

EL5WS026

in the bandswitch assembly 1A1A26, and controlled by the setting of the frequency dialed in on the front panel.

3-32. Power Amplifier and Driver 1A1A29 (fig. 3-28)

This module provides amplification for the 2-76 MHz signal from the transmit broadband 1A1A12. The signal level is raised to 3 watts output in the LO PWR mode and to 40 watts output in the HI PWR mode. A temperature sensing switch protects against development of excessive heat by switching the PA driver to LO PWR operation at 100° C (212°F).

a. LO PWR Mode. In LO PWR mode of operation, the signal is applied to a 6 dB pad for impedance matching before being sent to the predriver amplifier. This amplifier receives gain control voltage which is determined in the ALC 1A1A25. The signal is then sent to a driver amplifier for further amplification and through a broadband coupling network. From this point, the signal is sent to a relay that is controlled by the POWER switch on the front panel. When the switch is set to LO PWR, the signal is sent out to the harmonic filter 1A1A28 at approximately 3 watts.

b. HI PWR Mode. In the HI PWR mode of operation, the signal is routed the same as in the LO PWR mode until it reaches the relay. At this point, the signal is sent to a frequency compensation network and then divided into two signals by the input hybrid transformer. Both signals are sent through transformer assemblies, final amplifiers, and another set of transformer assemblies before reaching the output hybrid transformer. The output of the hybrid transformer is sent back to the relay before being sent out to the harmonic filter module at approximately 40 watts.

3-33. Quad Assembly 1A1A33 (fig. 3-29)

The function of the quad assembly is to drive the saturable reactors located in the coupler network

1A1A24, during a tune cycle.

a. Relay Assembly. When a tune cycle is initiated, the TUNE RLY SW input goes low, energizing the +24V relay, which supplies +24V to the quads.

b. Quads Assembly. The quad assembly consists of two sets of four transistors called quads. Transistors Q1 and Q2 on assembly A1 and Q1 and Q2 on assembly A2 make up the phase quad. Transistors Q3 and Q4 on assembly A1 and Q3 and Q4 on assembly A2 make up the resistance quad which works in a similar manner to the phase quad. Each quad consists of four darlington transistors which are connected such that current pulses of either polarity can be applied to the reactors. Inputs PQ1 and PQ2 are connected together through a 470 ohm resistor (on coupler 1A1A24) when the phase reactor is driven in one direction; inputs PQ3 and PQ4 are connected in a similar manner when the phase reactor is driven in the opposite direction. When the resistance reactor is driven, the inputs to the resistance quad behave similarly. The outputs to the reactors are in the form of a current pulse of variable duration dependent upon conditions existing in the coupler. A current sample supplies information to the coupler 1A1A24 control logic through QUAD REF to help set the length of the current pulses. The current sample resistor is a 0.18-ohm resistor. The 180-ohm resistor acts as a buffer to prevent high currents from damaging the coupler logic.

3-34 Bandpass Filter 1A1FL1

The bandpass filter attenuates frequencies above the range of 2-76 MHz. In the receive mode, the filter attenuates the first IF frequency (111.455 MHz) and the pump VFO frequencies (113.4550 to 187.4549 MHz), and prevents these frequencies from reaching the antenna. In the transmit mode, the filter attenuates harmonic outputs above 76 MHz. The operation is the same in both receive and transmit modes.

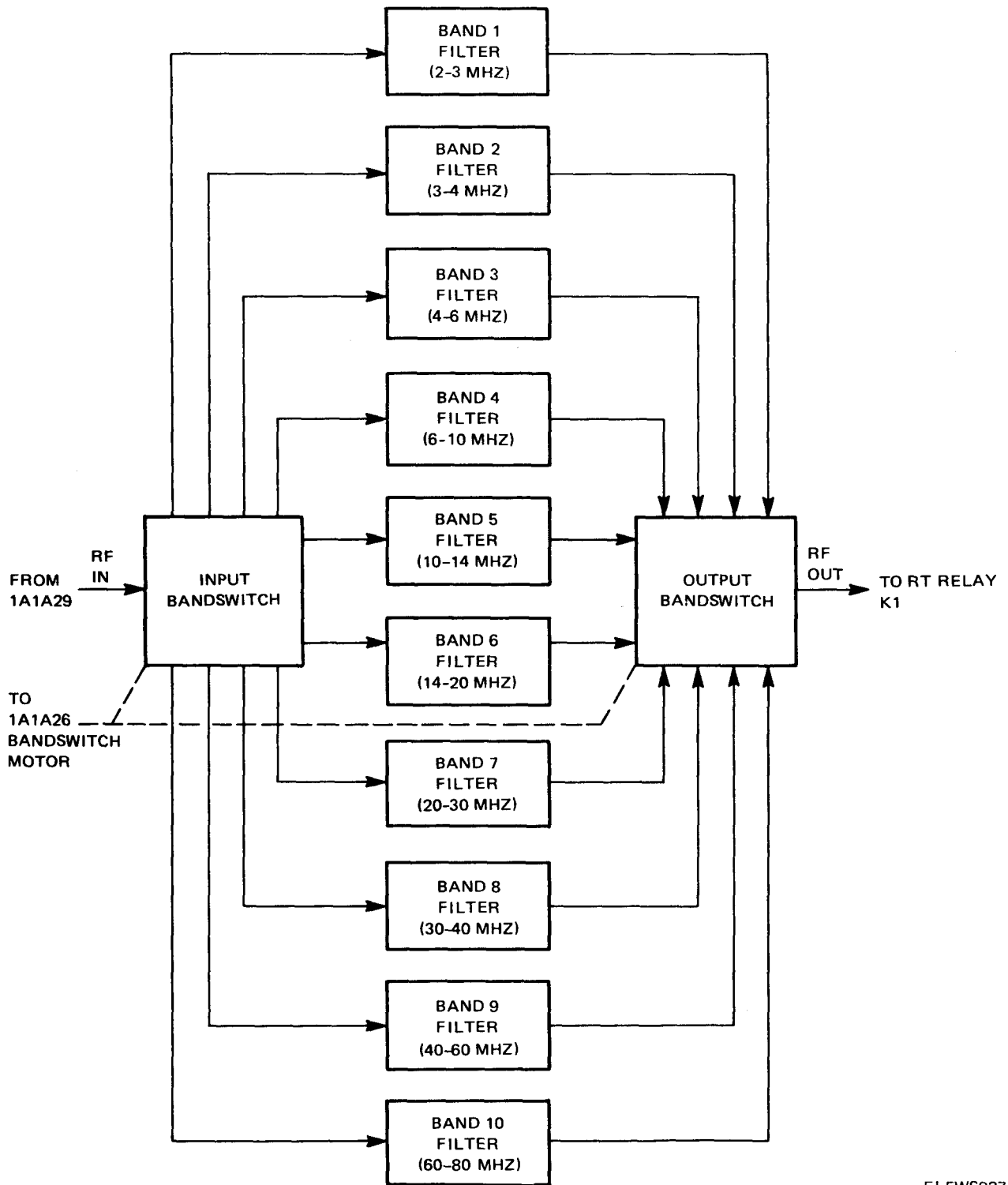

EL5WS027

Figure 3-27. Harmonic filter 1A1A28, block diagram.

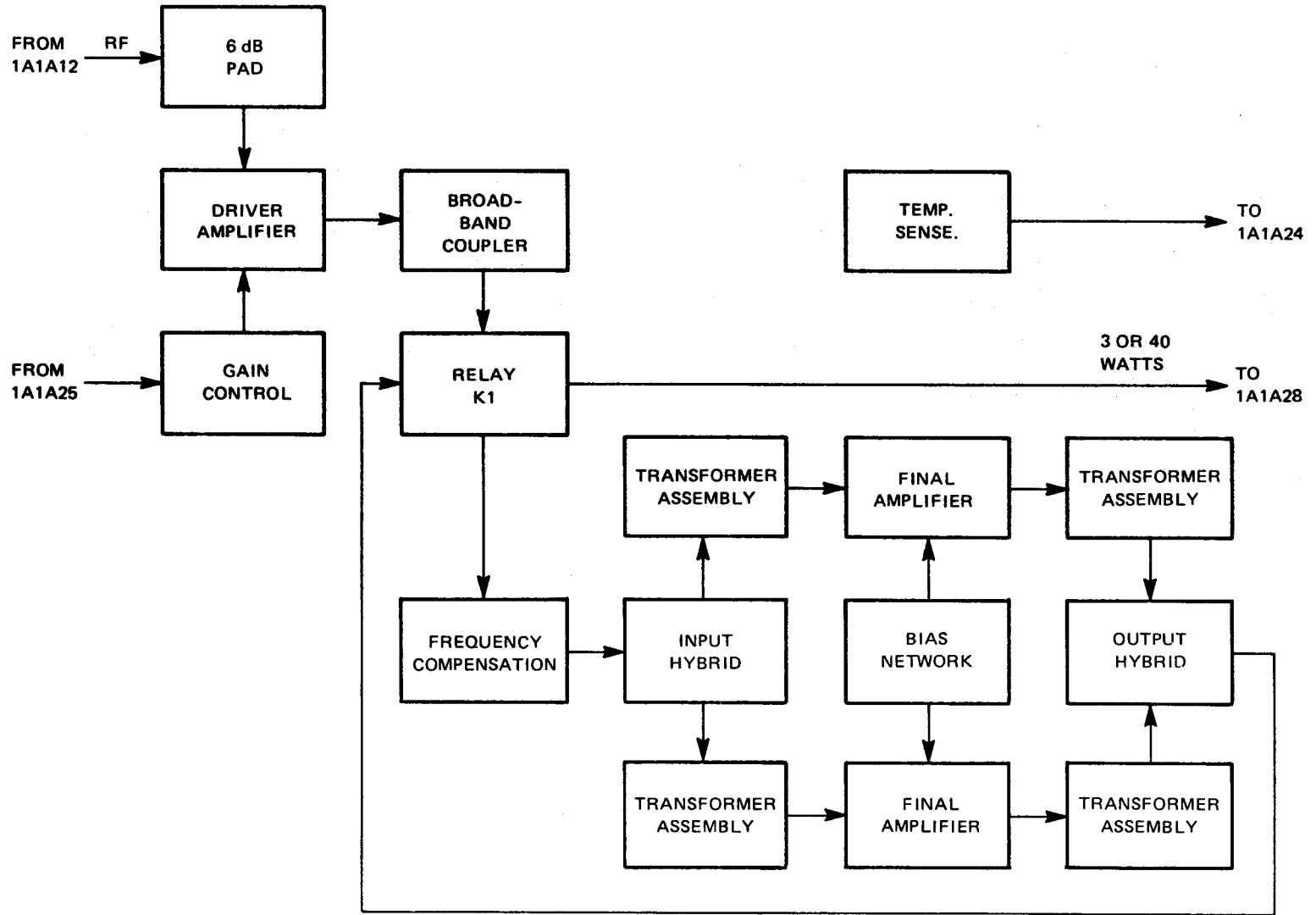

EL5WS028

Figure 3-28. Power amplifier and driver 1A1A29, block diagram.

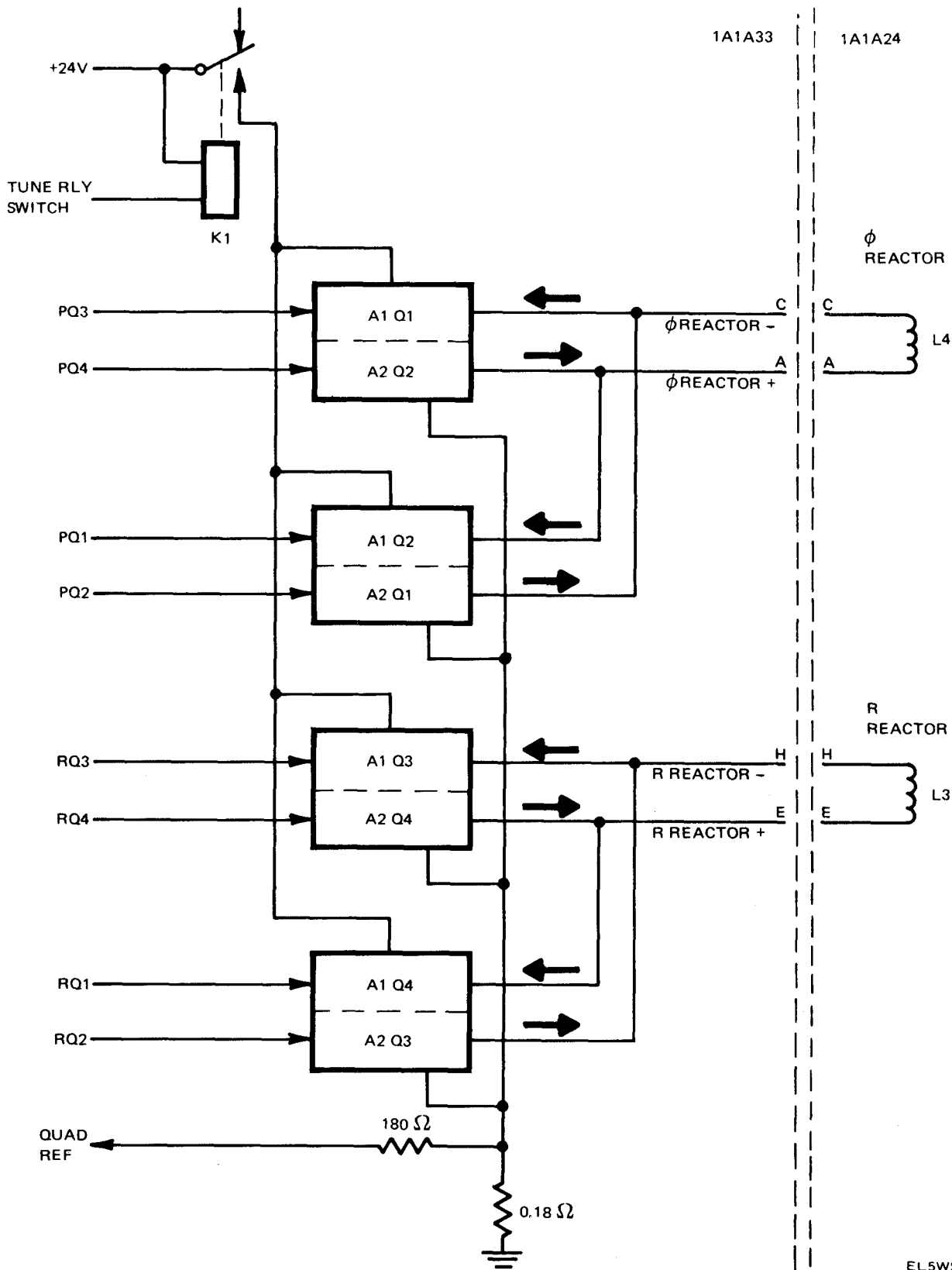

EL5WS029

Figure 3-29. Quad assembly 1A1A33, block diagram.

CHAPTER 4

DIRECT SUPPORT MAINTENANCE INSTRUCTIONS

Section I. General

4-1. Scope of Direct Support Maintenance

a. This chapter provides instructions for the direct support level of maintenance of the Receiver-Transmitter RT-1133/PRC-70 (RT unit). These instructions include:

- (1) Tools and test equipment (para 4-2).
- (2) Troubleshooting (para 4-3).
- (3) Removal and replacement procedures (para 4-8).

(4) Performance testing upon repair (para 4-11).

b. Refer to Operator's Manual for Radio Set AN/PRC-70 (TM 11-5820-553-10) for operating instructions and operator maintenance procedures. Refer to chapter 2 of this manual for organizational Preventive Maintenance Checks and Services (PMCS) and troubleshooting procedures.

Section II. Tools and Test Equipment

4-2. Tools and Test Equipment

Tools and test equipment required for direct support maintenance are listed in table 4-1.

Table 4-1. Tools and Test Equipment

Item	Purpose	Applicable publication
Tool Kit, Electronic Equipment TK-105/G.	Supplies tools for maintenance and repair of RT unit.	SC 5180-91-CL-R07
Voltmeter, RF AN/URM-145 (two required).	Measure voltage level of the RF outputs of individual modules in the RT unit.	TM 11-6625-524-15-1
Multimeter AN/USM-223/U.	Measures DC voltage levels such as the AGC voltages and the power supplies.	TM 11-6625-654-12
Power Supply, D.C. HP6214A.	Controls voltage to ALC circuit during tests.	
Generator, Signal SG-1093/U.	Provides AM and FM signals for signal injection to test operation of the receiver of the RT unit.	TM 9-4931-408-12
Oscilloscope AN/USM-281C.	Observes the waveforms in the RT unit to determine duration and voltage level of the signal under test.	TM 11-6625-2658-14
Counter, Electronic AN/USM-459.	Tests the frequencies developed in the RT unit.	TM 11-6625-2941-24P
Oscillator, Audio AN/URM-127 (2 required)	Provides audio signals in the 20 Hz to 20 kHz range for testing the RT unit.	TM 11-6625-683-15
Analyzer, Distortion AN/URM-184A.	Measures distortion of received signals in the RT unit.	TM 11-6625-1576-15
Power Supply, DC, HR40-7.5B, PP-4838/U.	Provides power for the RT unit while under test.	TM 11-6130-268-15
Attenuator, Step, 50 ohm CN-796/U.	Provides attenuation of output level so that proper level will be seen at input of the test equipment.	TM 11-5985-237-14P

Table 4-1. Tools and Test Equipment-Continued

Item	Purpose	Applicable publication
Deviation Meter, Marconi TF-791D.	Measures the 8 kHz to 10 kHz deviation.	OM 791D-USA
Adapter UG-201/U. RF Probe Tip Boonton 91-13B.	Provides BNC-to-N type connection. Provides tip to reach test points.	
RF Probe Adapter Boonton 91-6C.	Provides an unterminated 50-ohm connector.	
RF Probe Adapter Boonton 91-8B.	Provides a terminated 50-ohm load.	
100:1 Voltage Divider Boonton 91-7C.	Used when measuring greater than 3V.	
Handset H-250A/U. Attenuator, 30-dB 100W Pad (Hi-Power) Bird 8322.	To receive or transmit audio signals to or from the RT unit. Connects oscilloscope or deviation meter for monitoring of RF signal.	
Adapter UG-274A/U. Barrel Adapter UG-914A/U	Provides BNC-T connector for test measurement. Provides BNC connections for test measurements.	
Maintenance Cable Maintenance Kit consists of:	Connects power supply to RT unit. Contains special tools and test equipment required for maintenance on the AN/PRC-70 radio.	
Test Cable No. 1 CE TC1 (2 required).	Inserts or monitors RF inside the RT unit.	
Test Cable No. 2 CE TC2 (2 required).	Monitors RF at various points inside RT unit.	
Test Cable No. 3 CE TC3.	Provides BNC test point during ALC/PA test.	
A17 Extender X-Mode Test Box.	Extends 1A1A17 module to measure at test points Interfaces test equipment for wideband testing.	

Section III. Troubleshooting

4-3. General

This section provides information to troubleshoot defective AN/PRC-70 radios (RT units), isolate trouble sources to the module and circuit card level, and complete repairs by exchanging defective modules and circuit cards with operable replacements.

4-4. Troubleshooting Procedure

An RT unit must first be subjected to initial evaluation tests to be certain of need for repair and to accurately identify the problem. Evaluation tests are performed with the RT unit covers on. See figure 4-1. Completion of evaluation tests provides a log of input and output signals, voltage levels, frequencies, etc. This information is used as a guide to proceed with troubleshooting to isolate faulty modules or circuit cards. Troubleshooting is performed with the RT covers removed, unless otherwise indicated. Upon completion of troubleshooting and repair, a final performance test must be conducted to determine if the RT is

repaired and ready for return to service. The procedures used flow logically and lead to quick and accurate identification of faulty modules or circuit cards. There is a minimum of guesswork-type module changing. The system also aids understanding of the design of the radio, so that maintenance personnel are not operating unnecessarily "in the dark". This is important because this is a multifunction radio with advanced circuitry and is therefore somewhat complex. Another point of note is that test points and connection points are easily and safely reached with well marked drawings as guidance.

4-5. Initial Evaluation Tests

a. Receive Evaluation Tests.

(1) Receive evaluation test setup.

(a) Inspect RT for external defects or damage (see chapter 2).

(b) Check to see that POWER and SQUELCH switches on RT are OFF.

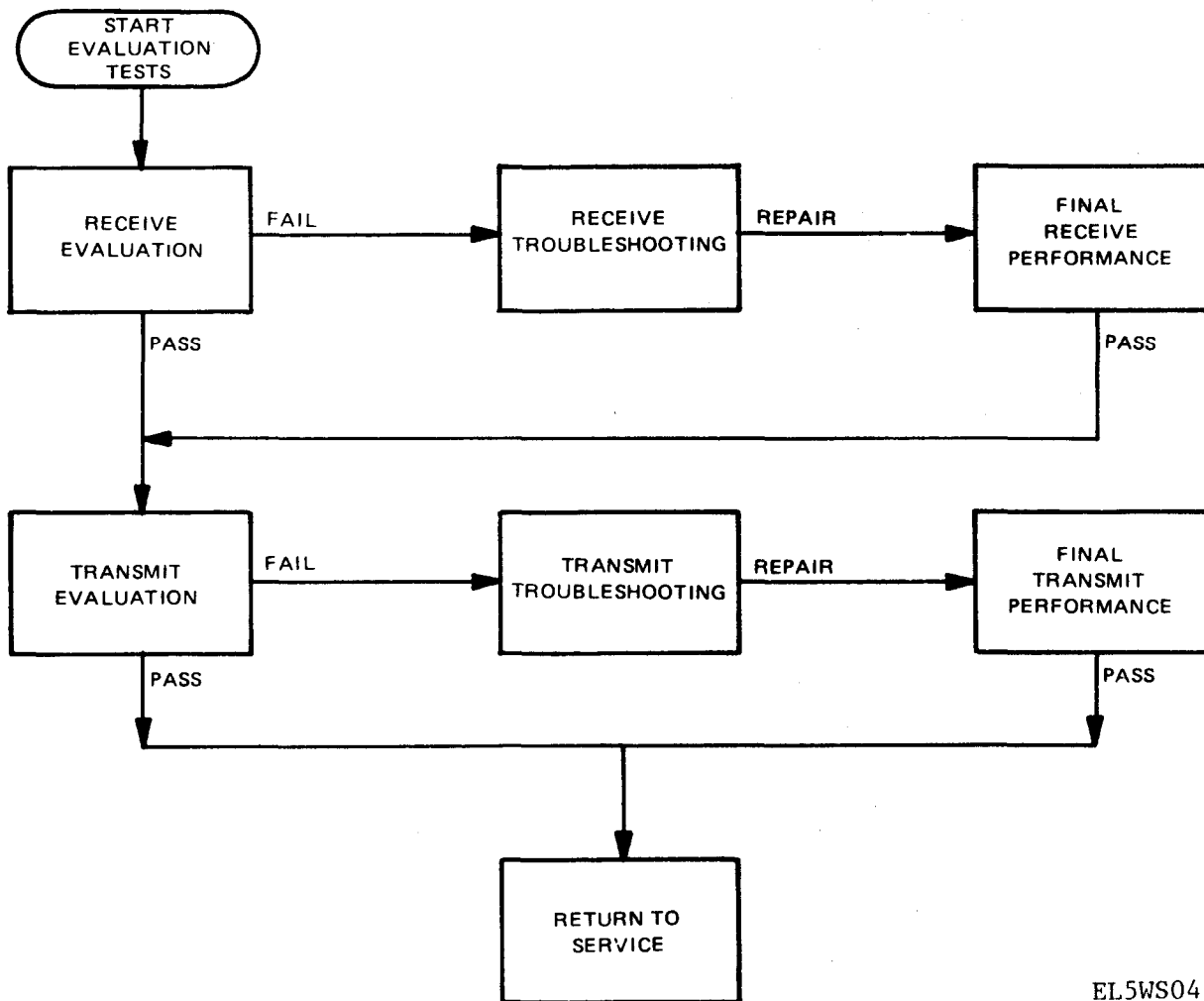

EL5WS043

Figure 4-1. AN/PRC-70 direct support maintenance procedures, block diagram.

CAUTION

Be sure polarity is correct when connecting the power supply to the radio.

(c) Connect RT and test equipment as shown in figure 4-2.

(d) Turn on test equipment and allow at least 30 minutes for warmup.

(e) Prepare receive evaluation data sheets similar to table 4-2 for use during receive evaluation testing. Do not write in this book.

(f) As each test is completed, one or more questions about that test must be answered by insertion of P (Pass) or F (Fail) on the data sheet.

(g) The next procedure is to determine the action required from the answer(s) to questions of (f) above.

(h) Do not begin troubleshooting procedures until directed to do so in test or figure during

evaluation testing. If a particular trouble is indicated during the tests, and further direction is not given, it must be noted along with test data for later evaluation.

(i) Follow directions to and from additional flow diagrams and/or instructions in the text during all testing.

(j) Figure 4-3 shows the path followed while receive evaluation testing.

(k) Figure 4-4 shows the RT operator controls.

(2) *Sensitivity test.*

CAUTION

Ensure the 30 dB Attenuator is connected between the ANT connector and

Table 4-2. Receive Evaluation Tests

Test No.	AN/PRC-70 Radio		Signal Generator ①			Sensitivity (dB) [Para 4-5a(2)]		AGC [Para 4-5a(3)]	Narrow Band Audio [Para 4-5a(4)]		RT # _____ Date _____			
			Freq. MHz	Mode	RF Microvolts into 30 dB Attenuator		RT Tuned?				RCV ONLY Position	Squelch [Para 4-5a(5)]	Retransmit [Para 4-5a(6)]	
	Freq. MHz	TUNE Position			RCV ONLY Position	SINAD > 10 dB			Level	Distortion	Level		Key	
1	2.150	AM	2.150	X ②	110	X		X	X	X	X	X	X	X
2	2.150	SSB	2.151	X	20	X		X	X	X	X	X	X	X
3	2.150	FM	2.150	X	20	X		X	X	X	X	X	X	X
4 ③	2.150	AM	2.150	X	200,000	X		X	X	X	X	X	X	X
5	2.150	AM	2.150	X	100,000 ④	X	X		X	X	X	X	X	X
6	2.150	AM	2.150	X	3,500	X	X	X			X	X	X	X
7	2.150	SSB	2.151	X	3,500	X	X	X			X	X	X	X
8	2.150	FM	2.150	X	3,500	X	X	X			X	X	X	X
9	2.150	AM	2.150	X	3,500	X	X	X	X	X		X	X	X
10 ⑤	2.150	AM	2.150	X	3,500	X	X	X	X	X	X			X
11	2.150	FM	2.150	X	3,500	X	X	X	X	X	X	X	X	
12	2.150	FSK	2.151	20	20	18	18							
13	2.150	CW	2.151	20	20	Same	—							
14	5.100	SSB	5.101	0	20	19	19							
15	8.400	SSB	8.401	0	20	19	19							
16	12.500	SSB	12.501	0	20	18	19							
17	17.322	SSB	17.323	0	20	17.5	16							
18	25.122	SSB	25.123	0	20	15	14							
19	35.055	FM	35.055	40	40	24	24							
20	40.055	FM	40.055	40	40	24	23							
21	50.222	FM	50.222	40	40	24	24							
22	60.122	FM	60.122	40	40	24	24							
23	75.122	FM	75.122	X	50	X	23							
24														

NOTES

- (X in any column means "do not perform this test")
- ① Sig. Gen. Modulation
AM: 30% at 1 kHz
FM: 8 kHz Deviation (5 kHz deviation for Test No. 11)
Others: CW
- ② Do not tune (TUNE position), or disregard.
- ③ Perform only if test nos. 1, 2, and 3 all fail.
- ④ Level into antenna connector for this test only.
- ⑤ Retransmit load equals 1 kilohm selectable on Isolation Box, all other tests are 500 ohm load.

Tested by _____

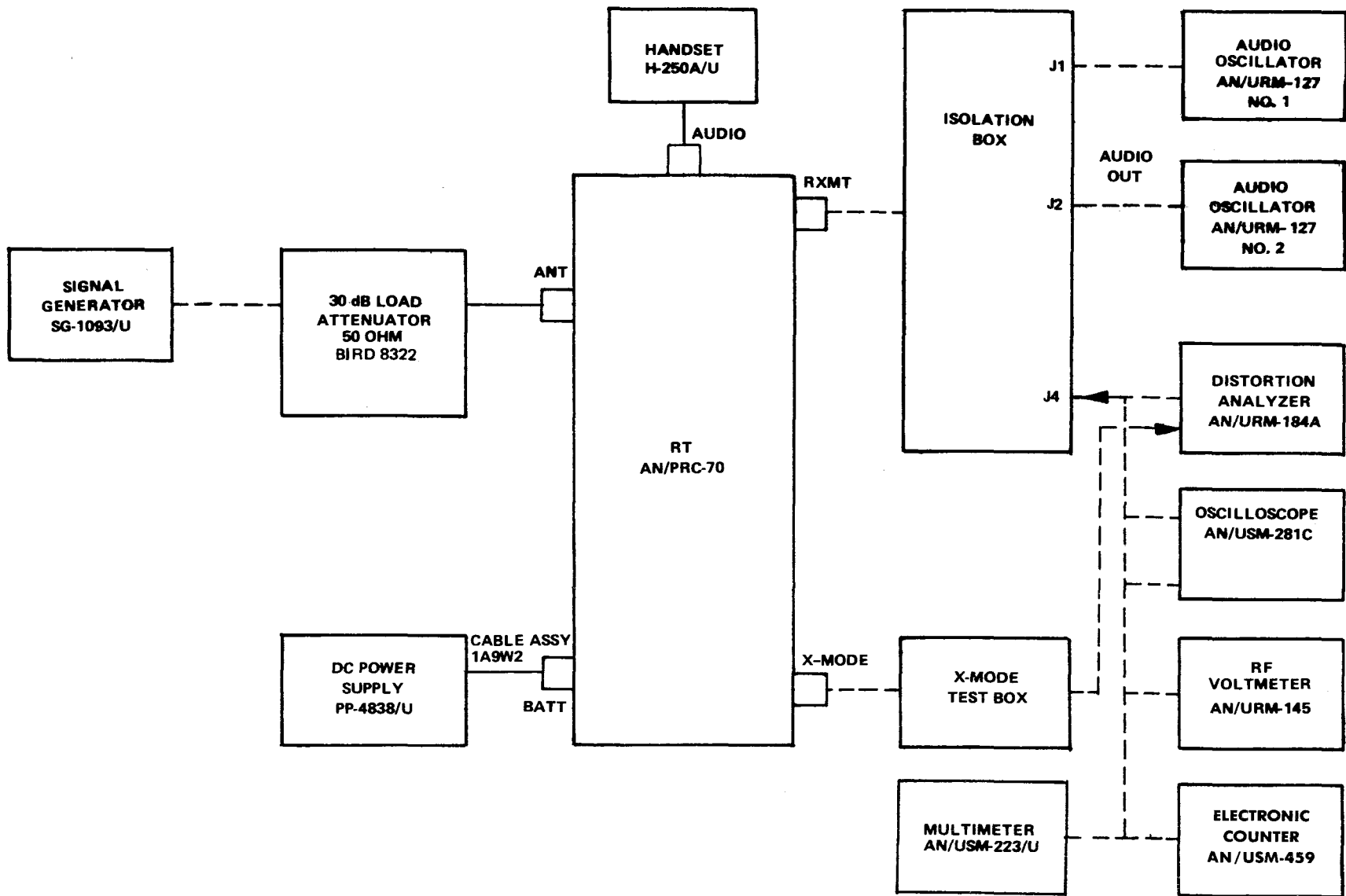

EL5WS044

Figure 4-2. Initial receive evaluation test setup.

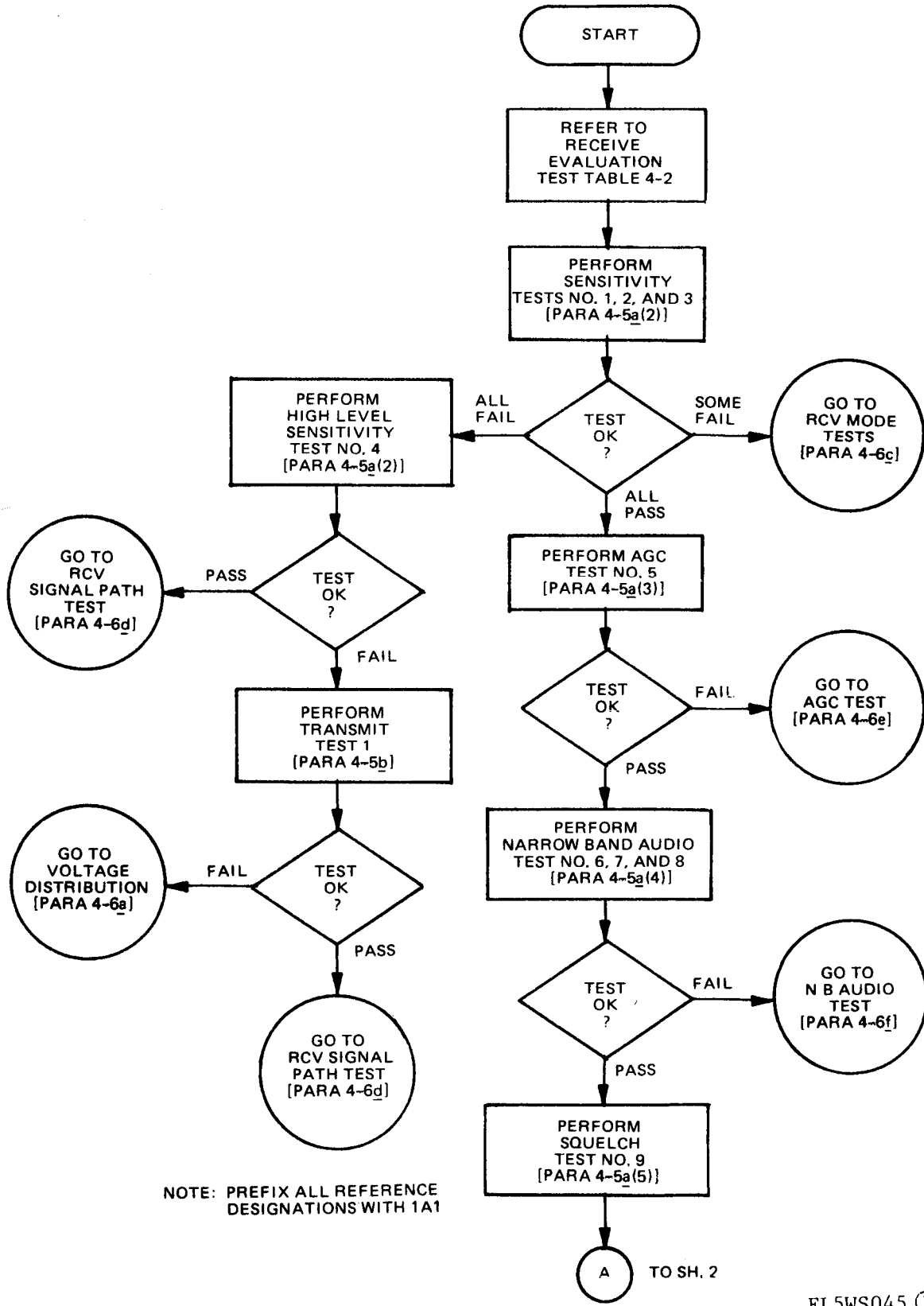

EL5WS045 ①

Figure 4-3. Receive evaluation test flow diagram (sheet 1 of 2).

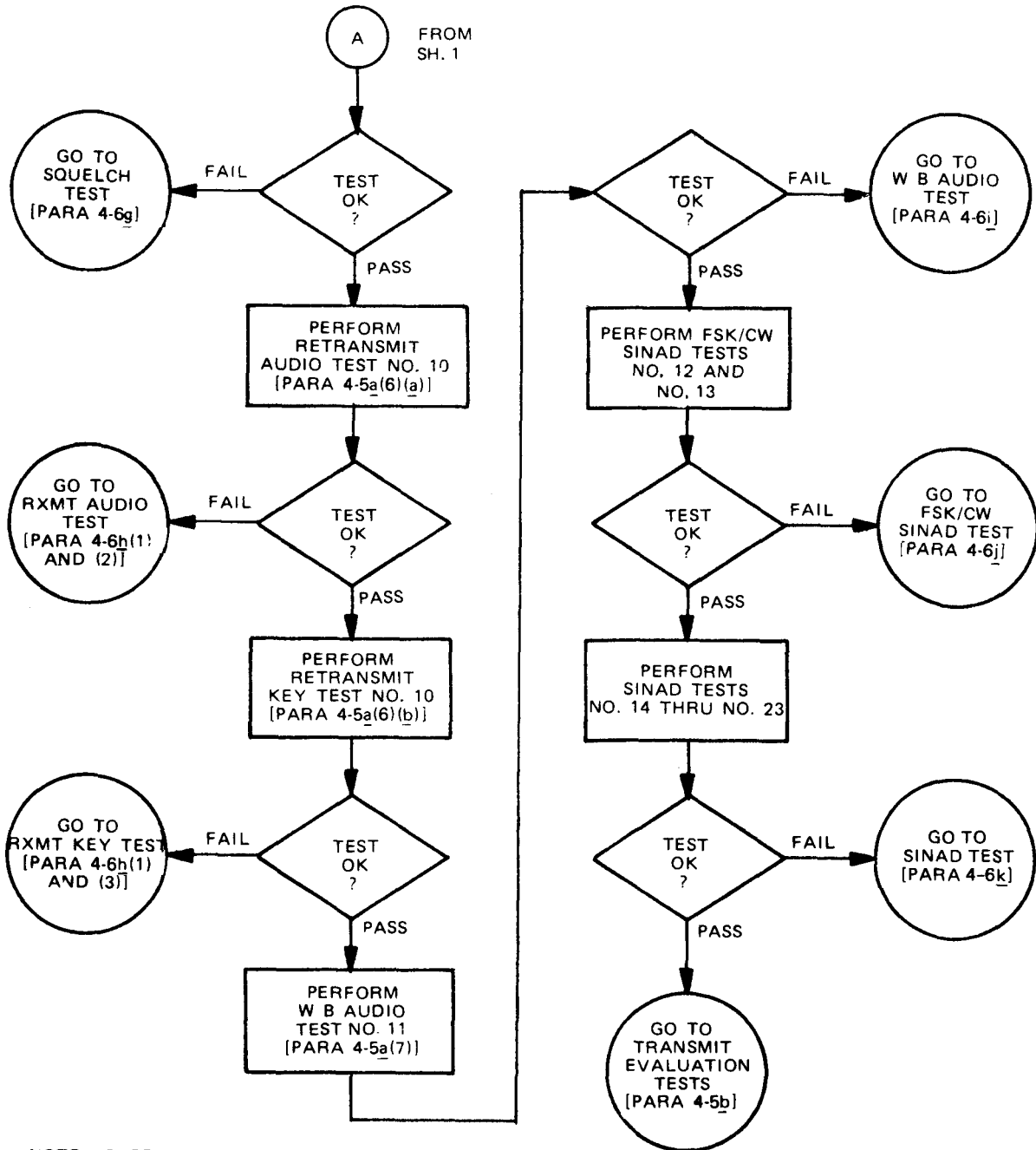

NOTE: PREFIX ALL REFERENCE DESIGNATIONS WITH 1A1

EL5WS045 ②

Figure 4-3. Receive evaluation test flow diagram (sheet 2 of 2).

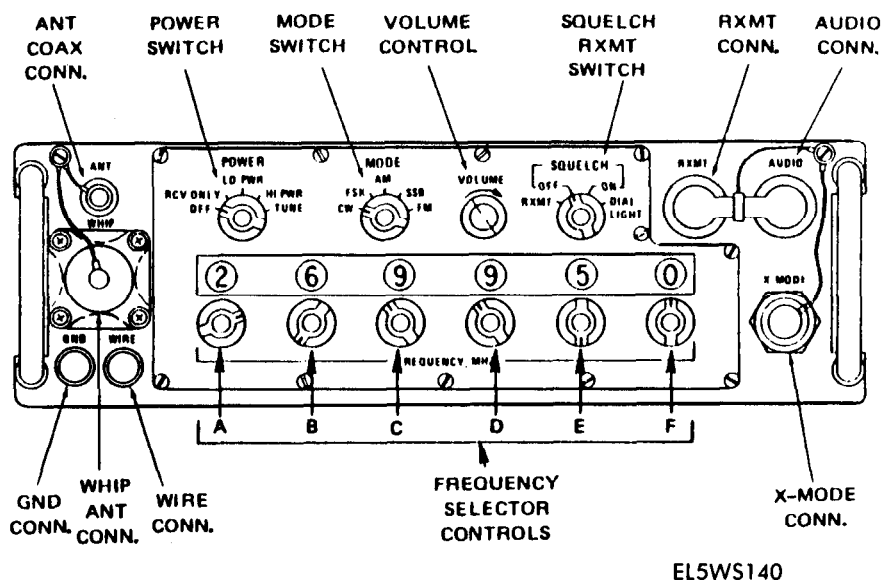

Figure 4-4. RT-1133/PRC-70 operator controls.

the Signal Generator before turning on the RT for testing.

(a) Sensitivity test setup.

1. Adjust power supply to $+24 \pm 0.5$ V dc output.

2. Turn on RT unit.

3. Set VOLUME control to midrange.

(a) If there is no noise heard (SQUELCH is OFF) in handset, then turn SQUELCH switch to DIAL LIGHT.

(b) If DIAL LIGHT is not on, connect X-Mode test box. Ensure transmit keying switch is not keyed.

(c) If X-Mode test box red lamp is not on, then go to Voltage Distribution Troubleshooting Tests, paragraph 4-6a.

4. Set Distortion Analyzer to VOLT-METER function and METER RANGE switch to 3 VOLTS.

(b) Low level sensitivity tests (No. 1, 2, and 3).

1. Check SINAD by performing the following steps.

NOTE

For each test to be performed in table 4-2 the RT must be set to the indicated frequency and mode, and the signal generator must be set to the indicated frequency, modulation, and level with POWER switch in position shown.

(a) Set RT and signal generator controls and switches to positions given in table 4-2 for test no. 1.

(b) Adjust RT VOLUME control for 1.5 ± 0.5 V rms as measured on distortion analyzer.

(c) Set distortion analyzer control to SET LEVEL and adjust SET LEVEL control for zero dB reference.

(d) Set distortion analyzer control to DISTORTION and null 1 kHz signal with distortion analyzer frequency control.

(e) SINAD is difference in dB between steps (c) and (d) above.

(f) An acceptable SINAD limit is 10 dB or more. Record P (Pass) or F (Fail).

2. Repeat step 1 above for test No. 2 and 33.

3. If tests No. 1, 2 and 3 all pass, go to AGC Test paragraph 4-5a(3) below. If tests No. 1, 2 and 3 all fail, go to High Level Sensitivity Test (para 4-5a(2)(c)). If some tests fail, go to Mode Troubleshooting Test paragraph 4-6c.

(c) High level sensitivity test (No. 4)

1. Set RT and Signal Generator controls and switches to positions given in table 4-2 test No. 4.

2. Perform Low Level Sensitivity Test (No. 1, 2, and 3) to check SINAD for test No. 4. Record P (Pass) or F (Fail).

(3) AGC test (No. 5).

(a) AGC test setup.

CAUTION

Do not tune the RT or key the Handset PTT switch when the Signal Generator is connected directly to the ANT connector.

1. Setup equipment as discussed in paragraph 4-5a(1) and shown in figure 4-2 except for the Step Attenuator. Connect the Signal Generator directly to the RT ANT connector for this test only.

2. Set RT SQUELCH switch to OFF.

(b) *AGC test.*

1. Set RT and Signal Generator controls and switches to positions given in table 4-2 test No. 5.

2. Adjust RT VOLUME control for an audio output level of 1.5 ±0.5 V rms as measured on Distortion Analyzer.

3. Check to see that distortion level is less than 10 percent. Record P (Pass) or F (Fail).

(4) *Narrow band audio test (No. 6, 7, and 8).*

(a) *Narrow band audio test setup.*

1. Setup equipment as discussed in paragraph 4-5a(1) and shown in figure 4-2.

2. Set RT SQUELCH switch to OFF.

(b) *Narrow band audio test.*

1. Set RT and Signal Generator controls and switches to positions given in table 4-2 test No. 6.

2. Set Distortion Analyzer to VOLT-METER function and METER RANGE switch to 3.0 volts.

3. Check to see that audio output level is more than 2.3 V rms measured on Distortion Analyzer. Record P (Pass) or F (Fail).

4. Adjust RT VOLUME control for an audio output level of 2.2 V rms measured on Distortion Analyzer.

5. Check to see that audio distortion is less than 10 percent. Record P (Pass) or F (Fail).

6. Set RT and Signal Generator controls and switches to positions given in table 4-2 test No. 7.

7. Check to see that audio output level is more than 2.3 V rms measured on Distortion Analyzer. Record P (Pass) or F (Fail).

8. Adjust RT VOLUME control for an audio output level of 2.2 V rms measured on Distortion Analyzer.

9. Check to see that audio distortion is less than 10 percent. Record P (Pass) or F (Fail).

10. Set RT and Signal Generator controls and switches to positions given in table 4-2 test No. 8.

11. Check to see that audio output level is more than 2.3 V rms measured on Distortion Analyzer. Record P (Pass) or F (Fail).

12. Adjust RT VOLUME control for an audio output level of 2.2 V rms measured on Distortion Analyzer.

13. Check to see that audio distortion is less than 10 percent. Record P (Pass) or F (Fail).

(5) *Squelch test (No. 9).*

(a) *Squelch test setup.*

1. Setup equipment as discussed in paragraph 4-5a(1) and shown in figure 4-2.

2. Set RT POWER switch to RCV ONLY.

3. Set RT SQUELCH switch to OFF.

(b) *Squelch test.*

1. Set RT and Signal Generator controls and switches to position given in table 4-2 test No. 9. (For this test only, the Signal Generator is set to 30 percent AM modulation at 500 Hz.)

2. Adjust audio output level to 1.5 V rms as measured on Distortion Analyzer.

3. Set RT SQUELCH switch to ON.

4. Check to see that audio output level remains at 1.5 V rms as in step 2 above.

5. Disconnect RF Signal Generator input to RT. Audio output level should drop by at least 20 dB. Record P (Pass) or F (Fail).

(6) *Retransmit test (No. 10).*

(a) *Retransmit test setup.*

1. Setup equipment as discussed in paragraph 4-5a(1) and shown in figure 4-2.

2. Set switch S2 on the Isolation Box to the 1000 ohms position.

3. Set RT SQUELCH switch to RXMT.

4. Set RT POWER switch to RCV ONLY.

5. Set RT VOLUME control to midrange.

6. Set RT and Signal generator controls and switches to positions given in table 4-2 test No. 10. (For this test, set the Signal Generator to 30 percent AM modulation at 500 Hz modulating frequency.)

(b) *Retransmit level test.*

1. Check to see that audio output level is more than 150 mV rms measured on Distortion Analyzer. Record P (Pass) or F (Fail).

2. Set RT VOLUME control to minimum (fully CCW).

3. Check to see that audio output level is same as in step 1 above. Record P (Pass) or F (Fail).

(c) *Retransmit key test.*

1. Set the Signal Generator to AM modulation at 30 percent and 500 Hz modulating frequency.

2. Set output level of Signal Generator to 3500 mV.

3. Check to see that resistance between Isolation Box J5 (positive lead to multimeter) and J6 (ground lead of multimeter) is less than 50 ohms measured on Multimeter AN/USM-223/U. Record P (Pass) or F (Fail).

4. Disconnect Signal Generator.

5. Check to see that resistance between Isolation Box J5 and J6 is more than 10,000 ohms measured on Multimeter AN/USM-223/U. Record P (Pass) or F (Fail).

(7) *Wide band (X-mode) audio response test (No. 11).*

(a) *Wide band audio response test setup.*

1. Setup equipment as discussed in paragraph 4-5a(1) and shown in figure 4-2.

2. Connect X-mode test box J2 banana connector to Distortion Analyzer.

3. Set RT SQUELCH switch to OFF.

(b) *Wide band audio response test.*

1. Set RT and Signal Generator controls and switches to positions given in table 4-2 test No. 11. FM deviation is set at 5 kHz on Signal Generator.

2. Check to see that audio output level of X-MODE connector J-2 is more than 250 mV rms measured on Distortion Analyzer. Record P (Pass) or F (Fail).

3. Set Signal Generator modulation frequency to 20 Hz.

4. Check to see that audio output level is within 2.5 dB from level to step 2 above. Record P (Pass) or F (Fail).

5. Set Signal Generator modulation frequency to 8 kHz.

6. Check to see that audio output level is within 0 to -5 dB from level of step 2 above. Record P (Pass) or F (Fail).

(8) *FSK/CW sensitivity test (No. 12 and 13).*

(a) *FSK/CW sensitivity test setup.*

1. Setup equipment as discussed in paragraph 4-5a(1) and shown in figure 4-2.

2. Set RT SQUELCH switch to OFF.

(b) *FSK/CW sensitivity test.*

NOTE

The POWER switch is spring-loaded in the TUNE position and automatically returns to the HI PWR position when released.

1. Set RT and Signal Generator controls and switches to positions given in table 4-2 test No. 12.

2. Tune RT. If RT will not tune, set RT power control selector to RCV ONLY.

3. Perform Low Level Sensitivity Test (No. 1), paragraph 4-5a(2)(b)1 to check SINAD for test No. 12. Record P (Pass) or F (Fail).

4. Set RF and Signal Generator controls and switches to positions given in table 4-2 test No. 13.

5. Perform steps as in 2 and 3 above to check SINAD for test No. 13. Record P (Pass) or F (Fail).

(9) *SSB sensitivity tests (No. 14 through No. 18).*

(a) *SSB sensitivity test setup.*

1. Setup equipment as discussed in paragraph 4-5a(1) and shown in figure 4-2.

2. Set RT SQUELCH switch to OFF.

(b) *SSB sensitivity tests.*

NOTE

The POWER switch is spring-loaded in the TUNE position and automatically returns to HI PWR position when released.

1. Set RT and Signal Generator controls and switches to positions given in table 4-2 for test No. 14.

2. Tune RT. If RT unit will not tune, set RT power control selector to RCV ONLY.

3. Perform Low Level Sensitivity Test (No. 1), paragraph 4-5a(1)(b)1 to check SINAD for test No. 14. Record P (Pass) or F (Fail).

4. Repeat steps 1, 2, and 3 above to check SINAD for tests No. 15 through 18. Record P (Pass) or F (Fail) for each test.

(10) *FM sensitivity tests (No. 19 through No. 23).*

NOTE

For Test No. 23, use only untuned RCV ONLY position of the RT POWER control selector.

(a) *FM sensitivity test setup.*

1. Setup equipment as discussed in paragraph 4-5a(1) and shown in figure 4-2.

2. Set RT SQUELCH switch to OFF.

(b) *FM sensitivity tests.*

NOTE

The POWER switch is spring-loaded in the TUNE position and automatically returns to HI PWR position when released.

1. Set RT and Signal Generator controls and switches to positions given in table 4-2 for test No. 19.

2. Tune RT. If RT unit will not tune, set RT POWER control selector to RCV ONLY.

3. Perform Low Level Sensitivity Test (No. 1), paragraph 4-5a(2)(b)1 to check SINAD for test No. 19, indicated in table 4-2. Record P (Pass) or F (Fail).

4. Repeat steps 1, 2 and 3 above to check SINAD for tests No. 20 through 23. Record P (Pass) or F (Fair) for each test.

b. Transmit Evaluation Tests. If Receive Evaluation Tests have all passed, proceed with Transmit Evaluation Tests. After receive and transmit evaluation tests have passed the RT may be returned to service. If transmit evaluation tests fail, follow troubleshooting procedures given in the text and diagrams for the next action to be taken. See figure 4-1.

(1) *Transmit evaluation test setup.*

(a) Inspect RT for external defects or damage (see chap 2).

(b) Check to see that POWER and SQUELCH switches on RT are OFF.

CAUTION

Be sure polarity is correct when connecting the power supply to the radio.

(c) Connect RT and test equipment as shown in figure 4-5.

(d) Turn on test equipment and allow at least 30 minutes for warmup.

(e) prepare transmit evaluation data sheets similar to table 4-3 for use during transmit evaluation testing. Do not write in this book.

(f) As each test is completed, one or more questions about that test must be answered by insertion of P (Pass) or F (Fail) on the data sheet.

(g) The next procedure is to determine the action required from the answer(s) to questions of (f) above.

(h) Do not begin troubleshooting procedures until directed to do so in text or figure during evaluation testing. If a particular trouble is indicated during the tests, and further direction is not given, it must be noted along with test data for later evaluation.

(i) Follow directions to and from additional flow diagrams and/or instructions in the text during all testing.

(j) Figure 4-6 shows the path followed while transmit evaluation testing.

(2) *AM and SSB output test (table 4-3, Test No. 1 and 2).*

(a) *AM power output test (table 4-3, Test No. 1).*

1. Set RT controls as follows:

<i>Control</i>	<i>Setting</i>
POWER	RCV ONLY
MODE	AM
FREQUENCY	2.1500 MHz
VOLUME	Midrange

2. Connect multimeter to ANT terminal through T-probe connector HP 11042A.

3. Adjust Audio Oscillator No. 1 for a fre-

quency of 1.5 kHz and level out of Isolation Box of 2 mV measured on the Distortion Analyzer.

4. Place RT into coupler Home position.

NOTE

Coupler Home is attained by setting RT POWER control from RCV ONLY to a power position without tuning. If coupler Home test fails during any of the test in table 4-3, replace 1A1A24 and repeat test.

5. Key RT in LO PWR. Check to see that output voltage is 7 to 16 V ac as measured on multimeter and current is less than 2.5 amperes as measured on power supply meter. Unkey RT.

6. Set RT POWER control to HI PWR. Key RT and check to see that output voltage is between 30 and 50 V ac and current is less than 7 amperes. Unkey RT.

7. If power output fails, go to Transmit Signal Path Test (para 4-7a).

8. If power output passes, proceed to test No. 2.

(b) *SSB distortion test (No. 2).*

1. Set RT controls as follows:

<i>Control</i>	<i>Setting</i>
POWER	RCV ONLY
MODE	SSB
FREQUENCY	2.1500 MHz
VOLUME	Midrange

2. Audio Oscillator No. 1 is disconnected for step 2 only. Connect Audio Oscillator No. 2 and adjust for 2.8 kHz at a level of 2 mV out of Isolation Box.

3. Reconnect Audio Oscillator No. 1

4. Place RT into Coupler Home position by setting POWER control to LO PWR.

5. Key RT and check to see that output voltage is more than 7 V ac and current is less than 2.5 amperes. Unkey RT.

6. Set RT POWER control to HI PWR. Key RT and check to see that output voltage is between 32 and 50 V ac and current is less than 5.5 amperes. Unkey RT.

7. Connect Oscilloscope to the output of the 30 dB attenuator.

8. Key RT.

9. Adjust Oscilloscope for a waveform base width of 4 to 6 divisions.

10. Test passes if waveform width at 75 percent amplitude is less than 70 percent of width, at base. Figure 4-7 shows this waveform.

11. Unkey RT unit.

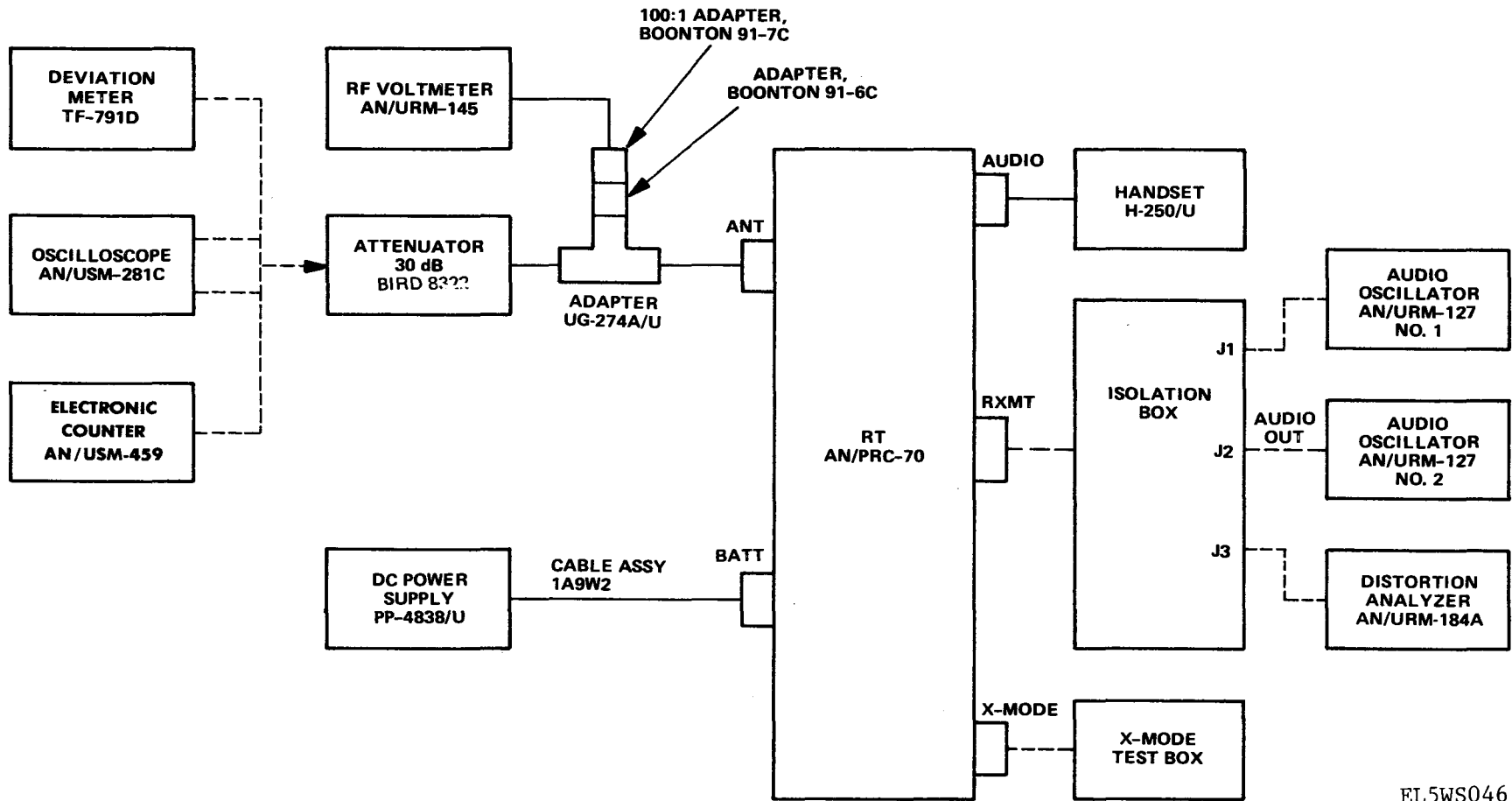

Figure 4-5. Initial transmit evaluation test setup.

EL5WS046

Table 4-3. Transmit Evaluation Tests

Test	Mode	Radio Frequency (MHz)	Coupler Status			Power						Modulation			
						LO		HI		Sidetone					
			Home	Tune	No-Tune Tone Present	E _{out}	I _{in}	E _{out}	I _{in}	LO	HI	% AM	Deviation FM	Distortion SSB	CW/FSK
1	AM	2.150		X	X					X	X	X	X	X	X
2	SSB	2.150		X	X					X	X	X	X		X
3	AM	2.150		X	X	X	X	X	X	X	X		X	X	X
4	SSB	2.150		X	X	X	X	X	X		X	X	X	X	X
5	AM	2.150		X		X	X	X	X	X	X	X	X	X	X
6	CW	2.150		X		X	X			X	X	X	X	X	
7	FSK	2.150		X		X	X			X	X	X	X	X	
8	SSB	3.900	X			X	X			X		X	X	X	X
9	SSB	5.100	X			X	X			X		X	X	X	X
10	SSB	8.400	X			X	X			X		X	X	X	X
11	SSB	12.550	X			X	X			X		X	X	X	X
12	SSB	17.322	X			X	X			X		X	X	X	X
13	SSB	25.122	X			X	X			X		X	X	X	X
14	SSB	35.055	X			X	X			X		X	X	X	X
15	FM	35.055	X			X	X				X	X	NB	X	X
16	FM	35.055	X			X	X	X	X	X	X	X	WB	X	X
17	FM	40.055	X			X	X			X		X	X	X	X
18	FM	50.222	X			X	X			X		X	X	X	X
19	FM	60.122	X			X	X			X		X	X	X	X
Spare															

- Note:
- X in any column means disregard.
 - Denote by P (Pass) or F (Fail) as tests are completed.
 - If No-Tune tone is heard in headset (2 kHz tone @ 2-3 Hz rate) during any power output measurement, coupler test failed.
 - Coupler Home - Obtained by setting POWER control to RCV ONLY and then to power shown, without tuning.

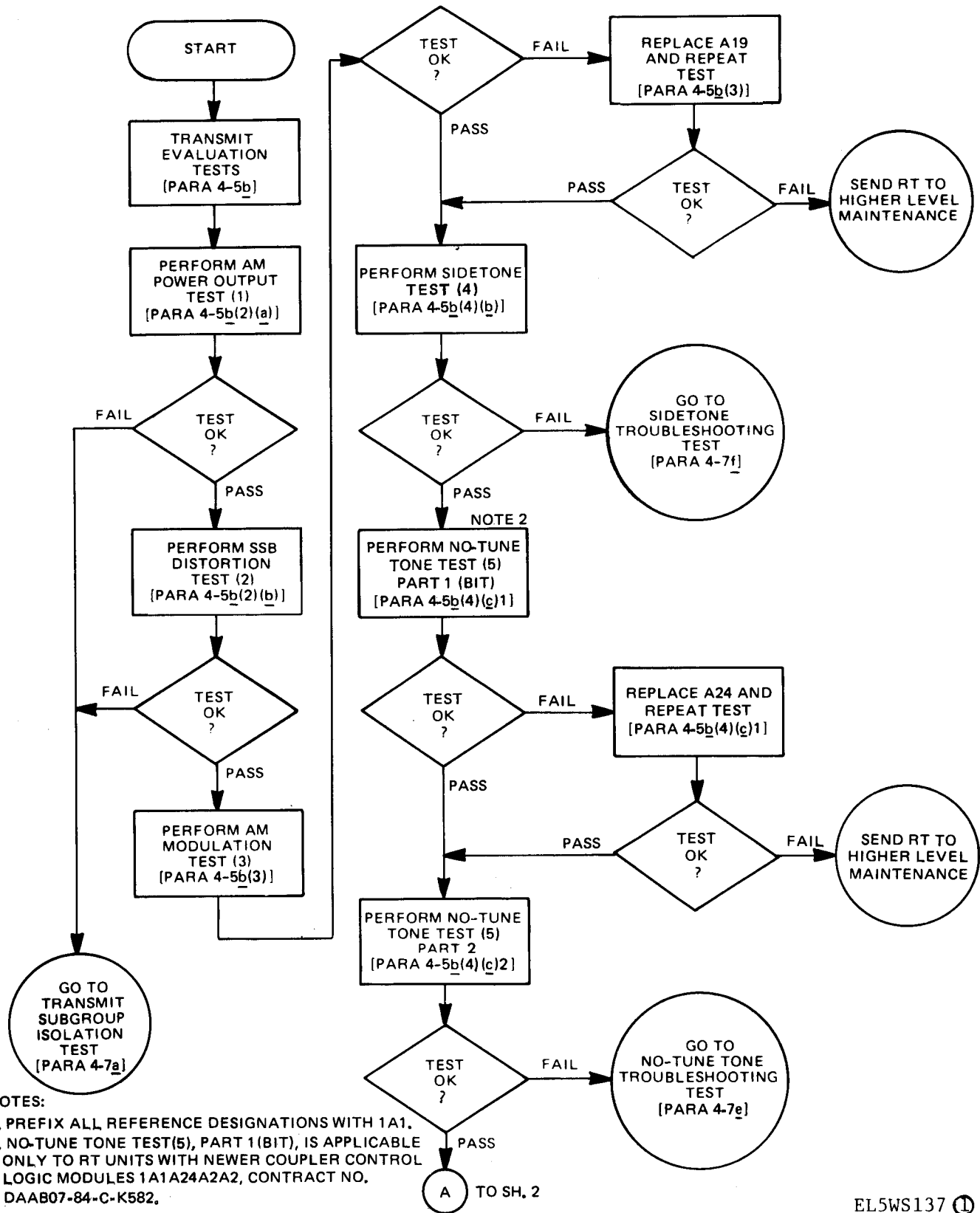
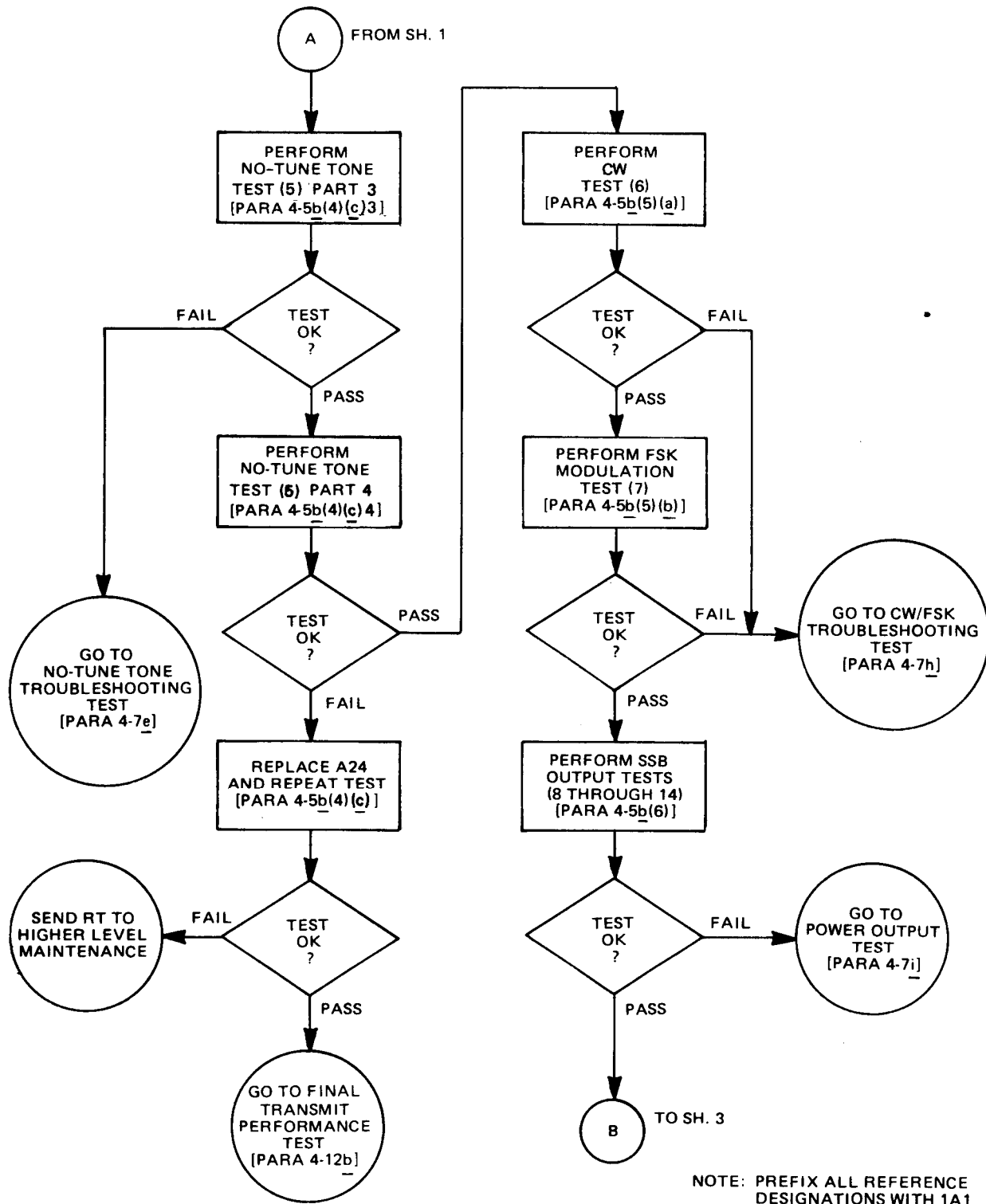

Figure 4-6. Transmit evaluation test flow diagram (sheet 1 of 3).



EL5WS137 ②

Figure 4-6. Transmit evaluation test flow diagram (sheet 2 of 3).

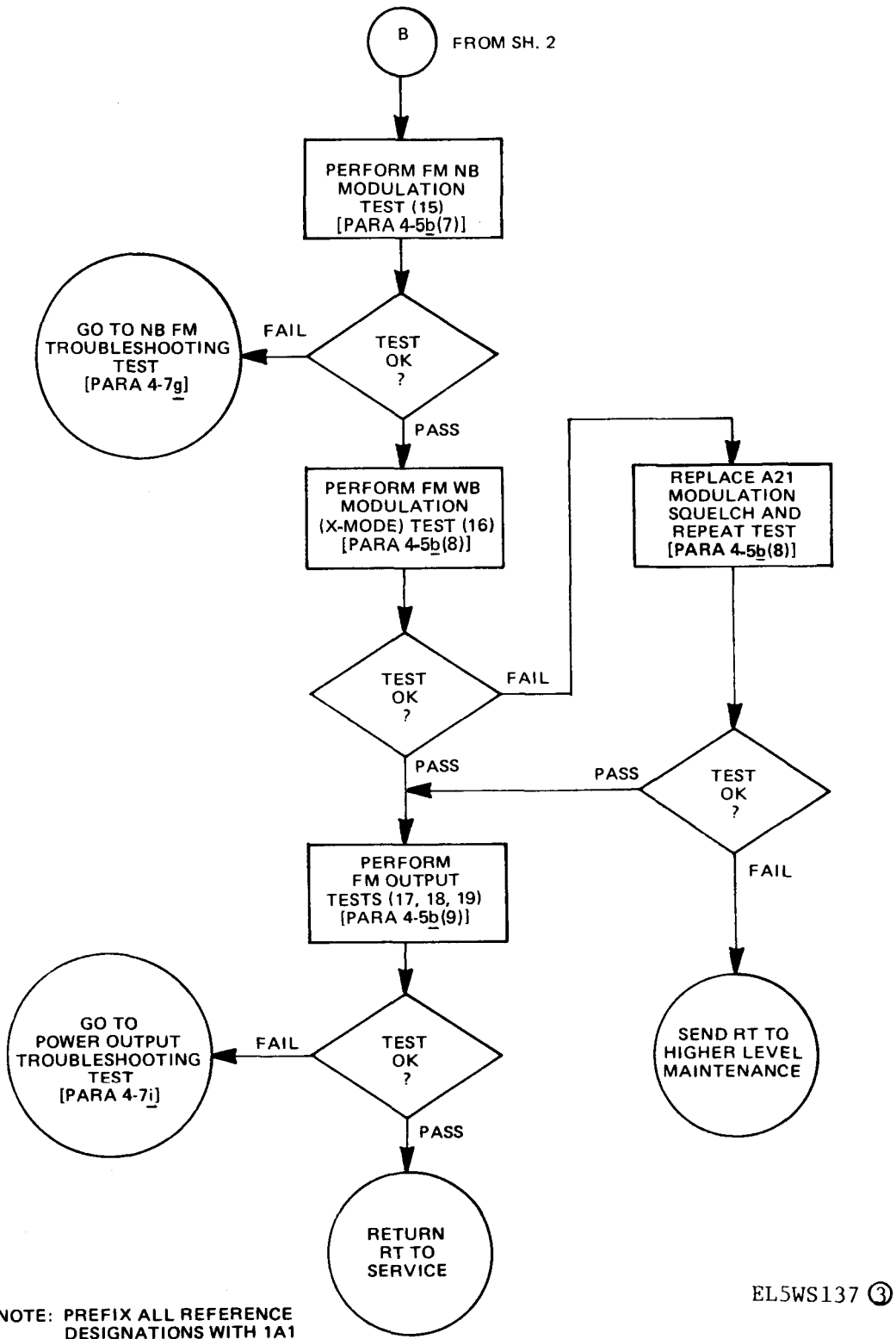
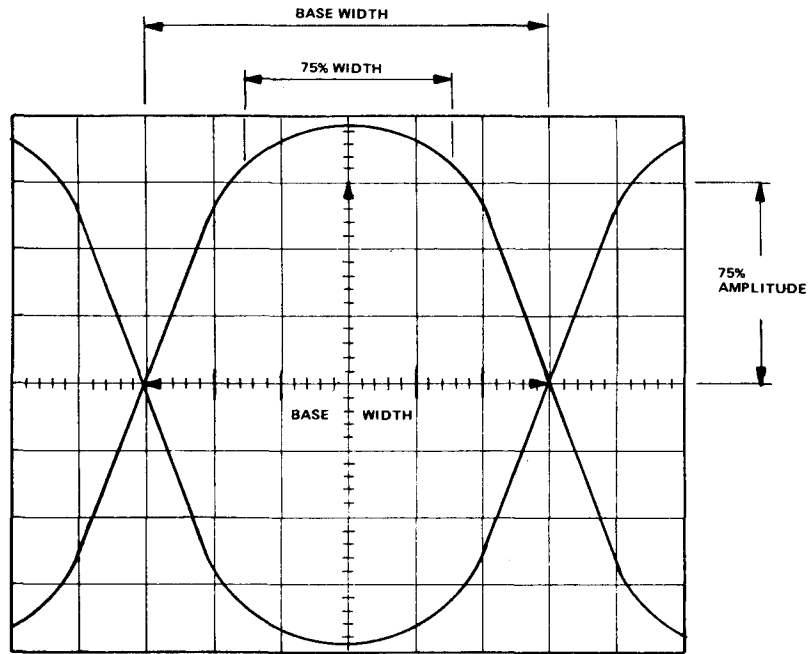

Figure 4-6. Transmit evaluation test flow diagram (sheet 3 of 3).



THE RATIO OF THE WIDTH AT 75% AMPLITUDE TO THE BASE WIDTH MUST BE LESS THAN 0.7.

Figure 4-7. Single side band distortion waveform.

EL5WS047

(3) AM modulation test (No. 3).

(a) Set RT POWER control to RCV ONLY, MODE to AM, and FREQUENCY to 2.150 MHz.

(b) Set Audio Oscillator to 1 kHz at a level out of Isolation Box of 2 mV.

(c) Place RT in Coupler Home position.

(d) Connect Oscilloscope to rear of 30 dB Attenuator.

(e) Key RT. Check to see that ratio of maximum voltage to minimum voltage is more than 3 to 1. Figure 48 shows this waveform.

(f) Unkey RT.

(4) Sidetone/No-tune tone test (No. 4 and 5).

(a) Test setup.

1. Set RT controls as follows:

Control	Setting
POWER	RCV ONLY
MODE	SSB
FREQUENCY	2.150 MHz

2. Set Audio Oscillator No. 1 to 2 kHz and adjust output level to 2 mV out of Isolation Box.

3. Disconnect Audio Oscillator No. 2.

4. Set RT POWER control to LO PWR.

(b) Sidetone test (No. 4).

1. Part 1.

(a) Key RT. A sidetone should be heard in handset.

(b) If test fails, proceed to figure 4-75, sheet 1.

(c) Unkey RT.

(d) Disconnect Audio Oscillator No. 1.

2. Part 2.

(a) Adjust Audio Oscillator No. 1 to 5 kHz while RT remains keyed.

(b) A sidetone should be heard. Check that output voltage is less than 4 Vac as measured on RF voltmeter.

(c) After approximately 10 seconds, sidetone should not be heard.

(d) Unkey RT.

(e) If test fails, proceed to figure 4-75, sheet 2.

(c) No-tune tone test (No. 5).

NOTE

Part 1 is applicable only to RT units with newer coupler control logic modules 1A1A24A2A2 (in coupler 1A1A24), Contract No. DAAB07-84-C-K582.

1. Part 1 (Built-in-Test) (BIT).

(a) Set RT controls as follows:

Control	Setting
POWER	OFF
MODE	AM
FREQUENCY	2.150 MHz

(b) Set RT POWER switch to TUNE and hold.

(c) Listen in handset. A No-Tune tone should not be heard.

(d) Release RT POWER switch.

(e) If No-Tune tone is heard, replace 1A1A24 and repeat test steps (a) through (d).

(f) If No-Tune tone is not heard, proceed to part 2 test.

2. Part 2.

(a) Set RT POWER control to RCV ONLY (coupler home position), and then to LO PWR.

(b) Key RT and listen in handset for a No-Tune tone (a 2 kHz tone burst at 2.4 Hz rate). A No-Tune tone should not be heard.

(c) Unkey RT.

(d) If test fails, proceed to figure 4-72.

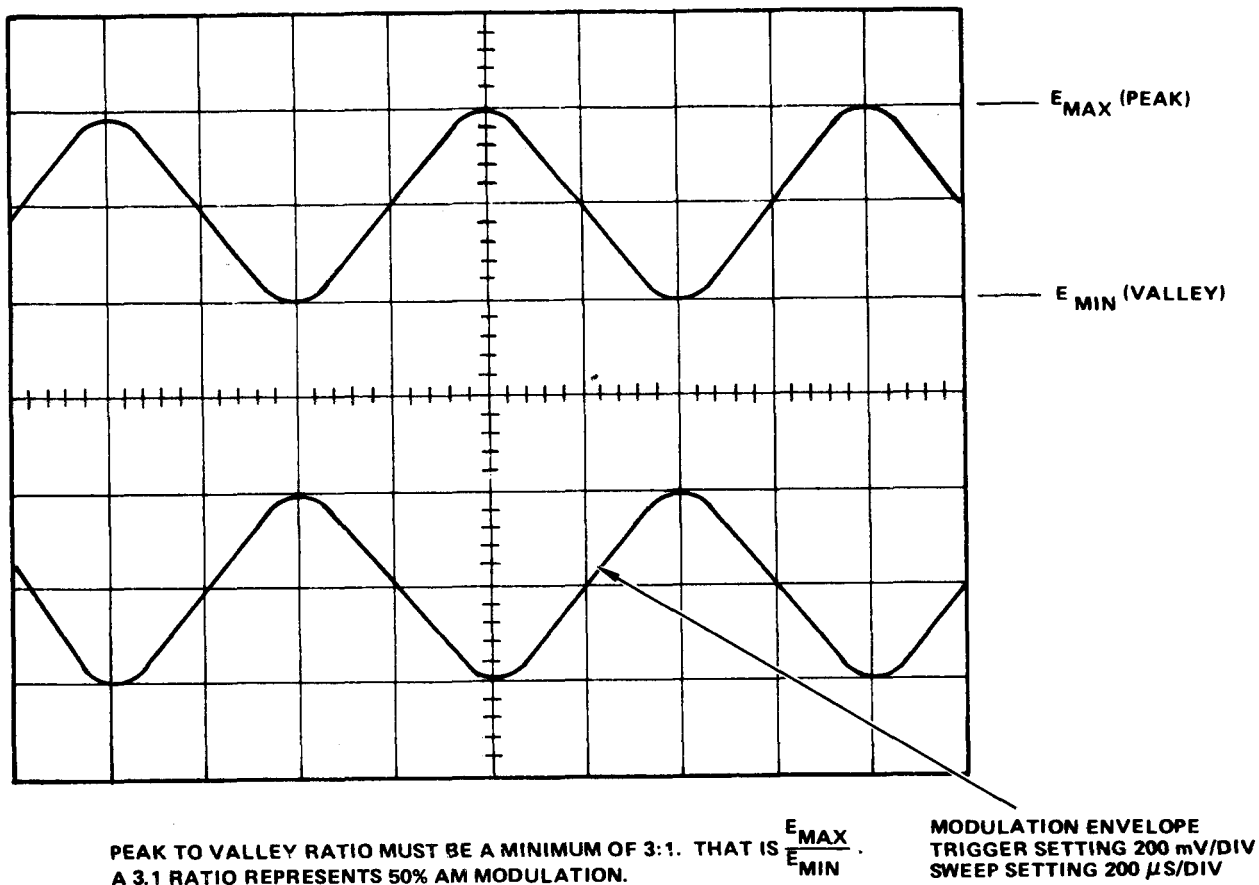

Figure 4-8. AM modulation waveform.

3. Part 3.

- (a) Disconnect coax from RT antenna to open antenna lead.
- (b) Set RT POWER switch to RCV and then to LO PWR.
- (c) Key RT.

NOTE

Two key operations may be required.

- (d) Listen in handset for No-Tune tone. The No-Tune tone *should* be heard.
- (e) Unkey RT.
- (f) If test fails, proceed to figure 4-72.

4. Part 4.

- (a) Reconnect 50 ohm RF cable with 30 dB Attenuator to ANT connector.
- (b) Set RT POWER switch to TUNE position and release.
- (c) After tuning is complete, set RT POWER switch to LO PWR.
- (d) Key RT. Listen for No-Tune tone.
- (e) Unkey RT.
- (f) If No-Tune tone is heard, replace 1A1A24 and repeat test step (b) through (e) above.
- (g) If No-Tune tone is not heard, proceed to Test No. 6 of table 4-3, paragraph (5).

(5) CW/FSK modulation test (No. 6 and 7).

(a) CW test (No. 6).

- 1. Connect Frequency Counter to 30 dB Attenuator and set resolution to 10 Hz.

- 2. Disconnect both Audio Oscillators.

- 3. Set RT MODE to CW and POWER control to HI PWR.

- 4. Key RT. Check to see that output frequency is 2.1520 MHz \pm 200 Hz.

- 5. Check to see that output voltage is between 32 and 50 V ac and current is less than 7 amperes.

6. Unkey RT.

(b) FSK test (No. 7).

- 1. Connect Frequency Counter to 30 dB Attenuator. Set RT MODE to FSK, and POWER switch selector to HI PWR.

- 2. Key RT and check to see that output frequency is 2.1516 MHz \pm 200 Hz.

- 3. Unkey RT. Check to see that immediately after unkeying, the output frequency momentarily indicates 2.1524 MHz \pm 200 Hz.

(6) SSB RF power output tests 8 to 14.

(a) Test setup.

- 1. Connect both Audio Oscillators to the Isolation Box.

- 2. Adjust Audio Oscillator No. 1 to 1500 Hz at 2 mV output.

3. Set RT Mode Control to SSB.
 4. Set RT POWER control to HI PWR.
- (b) Test No. 8.
1. Set RT FREQUENCY to 3.900 MHz.
 2. Tune RT.
 3. Key RT.
 4. Check to see that output voltage is between 28 and 49 V ac and current is less than 7 amperes. If voltage or current are not within limits, test failed.

5. Unkey RT.

(c) Tests No. 9 through 14. Repeat test procedures of test No. 8 for tests No. 9 through 14 at the respective frequency given in table 4-3.

(7) FM modulation test (No. 15).

(a) Test setup.

1. Disconnect Audio Oscillator No. 2 and set Audio Oscillator No. 1 for a frequency of 1 kHz with Isolation Box output of 2 mV \pm 0.3 mV.

2. Set RT POWER control to HI PWR and MODE control to FM, and FREQUENCY to 35.055 MHz.

3. Tune RT.

(b) Output test.

1. Key RT.
2. Check to see that output voltage is between 28 and 49 V ac and current is less than 7 amperes. If voltage and current are not within limits, the test failed.

3. Unkey RT.

(c) Modulation test of composite (audio plus 150 Hz).

1. Connect Deviation Meter to rear of 30 dB Attenuator.

2. Set RT POWER control to LO PWR.

3. Key RT. Check to see that modulation is between 8 kHz and 13 kHz. If modulation is not between 8 and 13 kHz, the test failed.

4. Unkey RT. Disconnect Isolation Box.

(d) 150 Hz test.

1. Disconnect Audio Oscillator.

2. Key RT.

3. Check to see that 150 Hz signal is between 2.4 kHz and 4.0 kHz on Deviation Meter. If modulation is not within limits, test failed.

4. Unkey RT.

(8) Wide band X-mode test (No. 16).

(a) Test setup.

1. Connect the output of Audio Oscillator No. 1 to both the X-Mode test box (FXD cable with BNC terminal) and oscilloscope.

2. Set oscillator frequency to 1000 Hz.

3. Adjust output level to 12V peak to peak on oscilloscope.

4. Set RT POWER control to LO PWR.

5. Set MODE control to FM.

6. Set FREQUENCY to 35.055 MHz.

(b) Wide band deviation test.

1. Tune RT.

2. Key RT.

3. Measure FM deviation.

4. Test passes if peak deviation is between 3 and 7 kHz.

5. Unkey RT.

6. Reconnect Audio Oscillator to Isolation Box.

(9) FM power output tests (No. 17, 18, and 19).

(a) Test setup.

1. Connect Audio Oscillator No. 1 to Isolation Box.

2. Adjust Audio Oscillator level to 2 mV into RT.

3. Set RT MODE control to FM.

4. Set RT POWER control to HI PWR.

(b) FM power output test No. 17.

1. Set FREQUENCY to 40.055 MHz.

2. Key RT.

3. Check to see that DC input current is less than 7 amperes.

4. Check to see that RF output voltage is between 28 and 49 V ac.

5. Test passes if requirements of 3 and 4 are met.

(c) FM power output tests No. 18 and 19.

1. Repeat test procedures of test No. 17 for tests No. 18 and 19 of table 4-3 at the respective frequency.

2. If test No. 19 passes and all previous evaluation tests pass, return RT to service.

4-6. Receive Functional Troubleshooting Tests

The receive troubleshooting tests are listed in table 4-4. The applicable text paragraph is given for each test. Perform the tests in the order given or directed in the associated troubleshooting diagrams. RT unit covers are removed while troubleshooting (para 4-10a).

CAUTION

The minicoaxial (coax) cable connections on the bottom of the RT unit are held in their jacks with crimped coax retainers. To disconnect the coax cable when testing, use a pair of needle nose pliers. Bend up the retaining "ears" on the spring clips just enough to permit the cable connection to be parted.

Table 4-4. Receive Troubleshooting Tests

Test	Paragraph
Voltage Distribution	4-6a
Synthesizer	4-6b
Mode	4-6c
Receive Signal Path	4-6d
AGC	4-6e
Narrow Band Audio	4-6f
Squelch	4-6g
Retransmit	4-6h
Wide Band Audio	4-6i
FSK/CW Sinad	4-6j
SINAD	4-6k

a. Voltage Distribution Troubleshooting Test.

CAUTION

Be sure polarity is correct when connecting the power supply to the RT.

- (1) Connect test equipment as shown in figure 4-9.

CAUTION

Current from power supply must be limited to 10 amperes.

- (2) Turn on test equipment and allow at least 30 minutes for warmup.

CAUTION

Insure the 30 dB Attenuator is connected between the ANT connector and the Signal Generator prior to energizing the RT for testing.

- (3) Adjust power supply for +24 ±1.5 V dc.
- (4) Set RT controls as follows:

Control	Setting
POWER	OFF
MODE	AM
FREQUENCY	2.150 MHz

- (5) Check voltage at 1A1A31 terminals E73 and E15, shown on test point diagram figure 4-10.

Figure FO-9 (sheet 1) shows the detailed block diagram.

(6) Figure 4-11 shows the path followed while troubleshooting voltage distribution circuits.

(7) If +24 V dc is present at both terminals, proceed to step (8).

(8) If +24 V dc is not present at 1A1A31-E73, battery connector may open. Check continuity between battery connector 1A1J6 pin 5 and 1A1A31-E73 and between Pin 1 and 1A1A31-E55 (or case). If the supply voltage is present at E73 but not at E15, proceed as follows:

NOTE

Check to see that X-mode connector is in place.

- (a) Remove TR Relay 1A1A2.
- (b) Turn off 24 Vdc power supply.
- (c) Check E15 resistance to ground to confirm fault (short) is not in power line.
- (d) Turn on 24 Vdc power supply.
- (e) Check continuity of both fuses and series diode CR3 located on 1A1A2. Replace defective component.
- (f) Install module 1A1A2 in RT.
- (g) Set power supply voltage to +40 V dc ±0.5 V dc and limit current using a 4.7K resistor in series with the input to the RT.
- (h) Check CR4 Zener Voltage, figure FO-9. If voltage is more than 36 V or less than 31 V, replace CR1 zener.
- (9) Adjust power supply to 24 V dc ±0.5 V.
- (10) Remove series resistor.
- (11) Set RT Mode control to RCV ONLY.
- (12) Check voltage at terminal E1 is 23.08 ±0.2 V dc.
- (13) Measure and record voltages listed below.

Test	Voltage Limits	A31 E-Terminal	(For Reference Only) Module & Pin Location		
			1A1A2	1A1A4	1A1A5
1	-5V	±0.3 E75	11		7
2	+5V (D)	±0.3 E56		11	
3	+5V (A)	±0.3 E58	15	9	
4	+10V	±0.3 E57	7.25	12	

CAUTION

Before proceeding to next step, ensure the 50 ohm RF Voltmeter load is connected to the broadband amplifier, A 12, breaking the signal path to the PA.

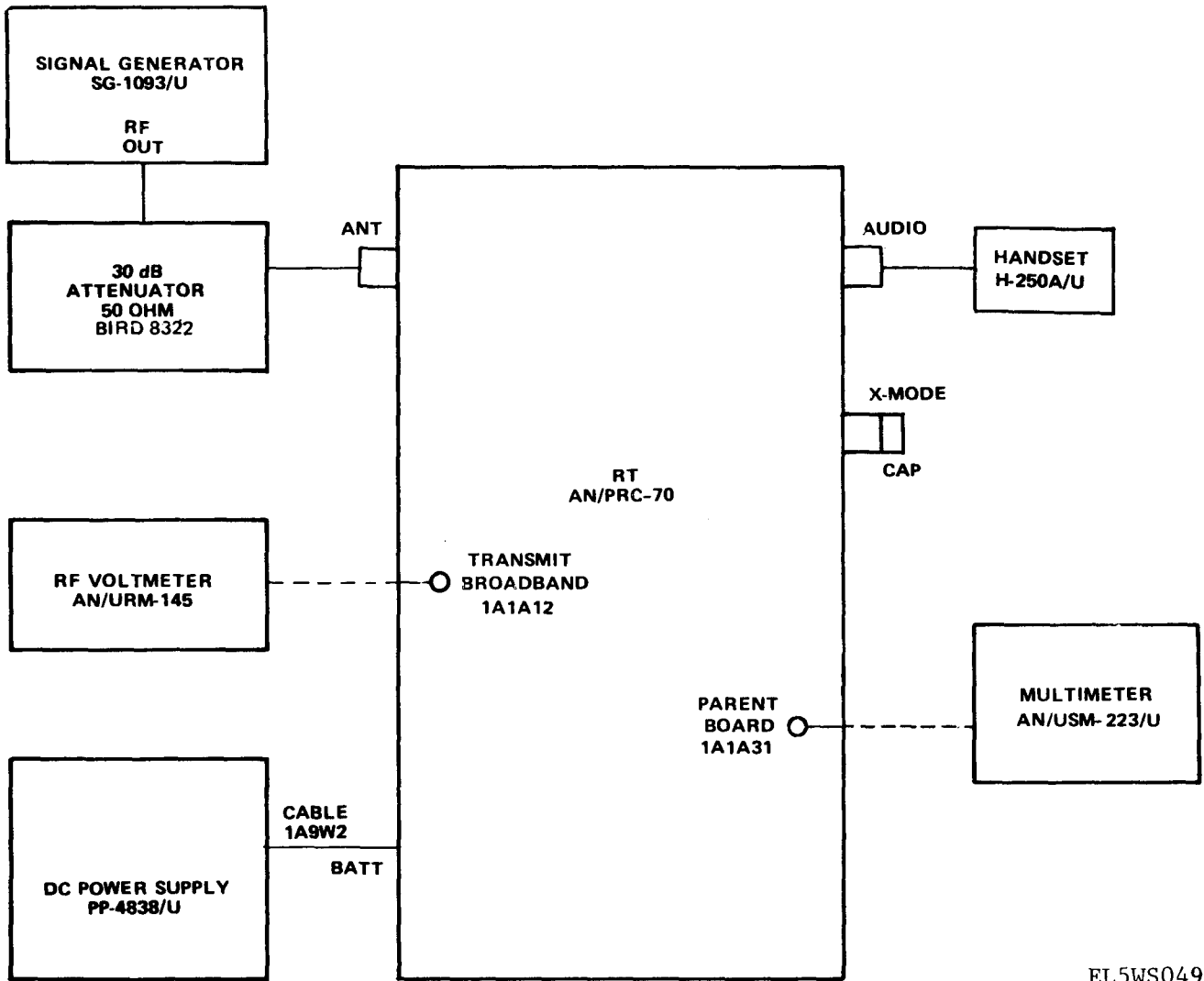

EL5WS049

Figure 4-9. Voltage distribution test setup.

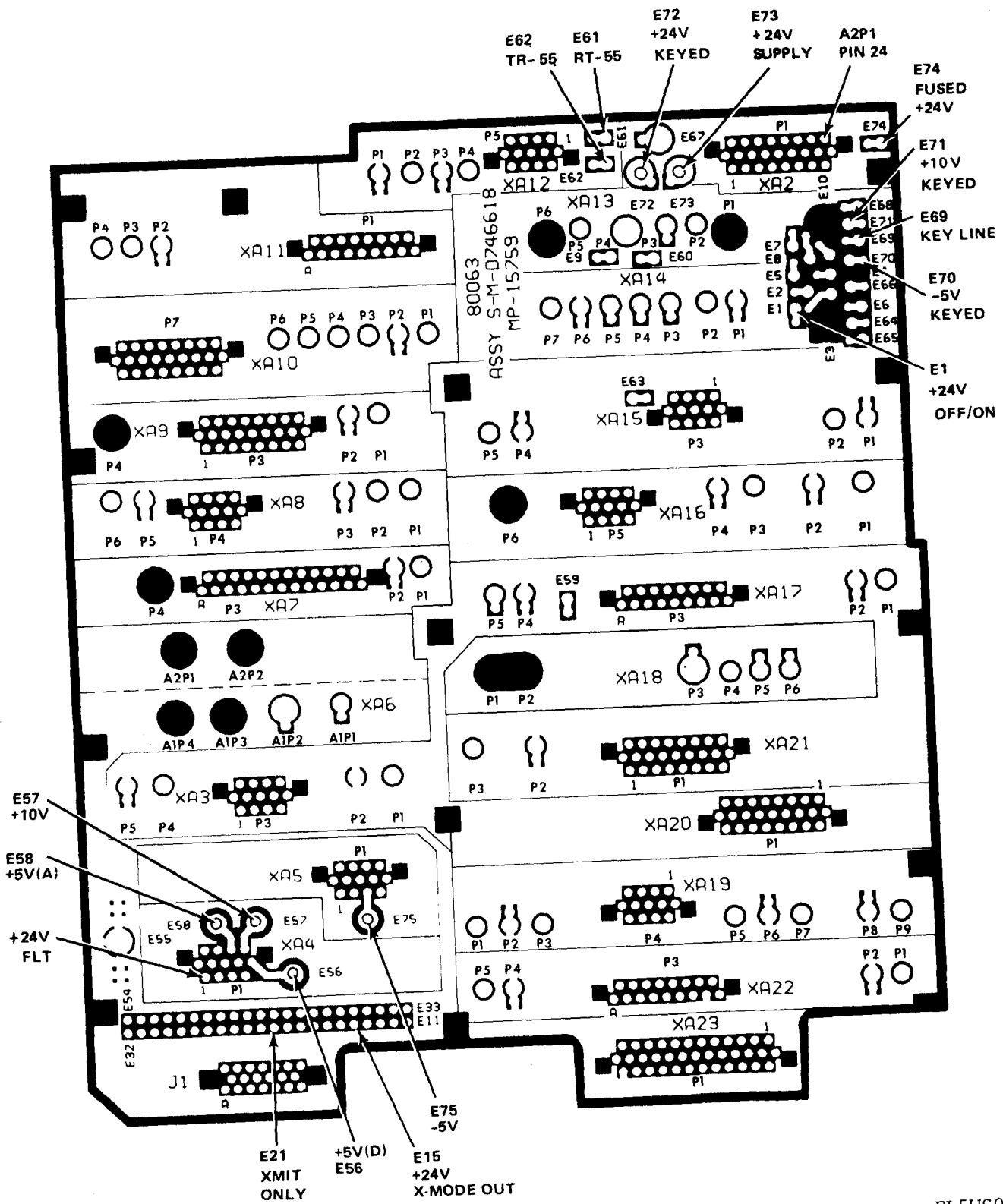

NOTE: PREFIX ALL REFERENCE DESIGNATIONS WITH 1A1A31.

Figure 4-10. Voltage distributing test point location.

EL5WS050

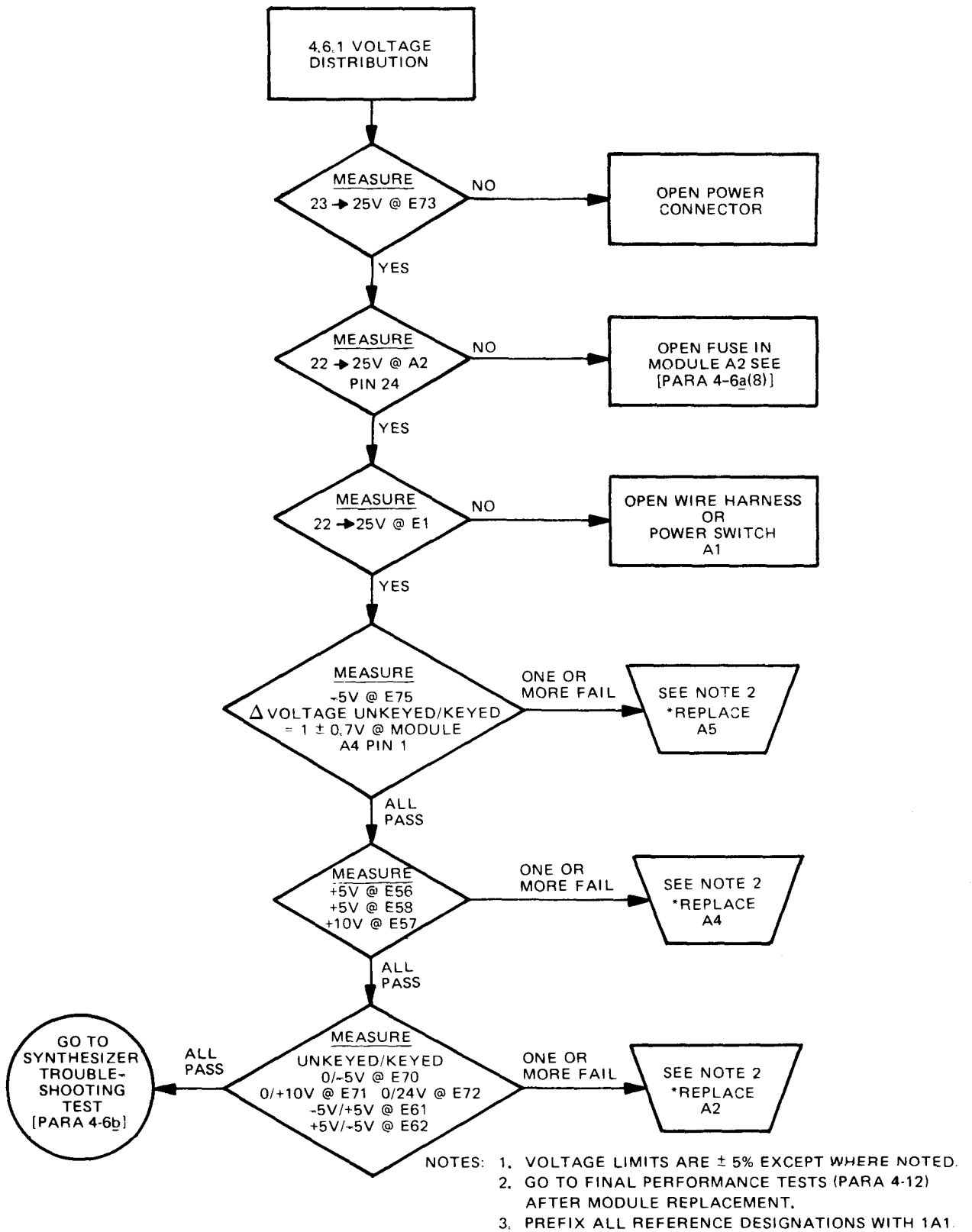

Figure 4-11. Voltage distribution troubleshooting diagram.

EL5WS051

NOTE

Relays 1A1A2K1, 1A1A2K2, and 1A1A5K1 are activated when keyed in all power modes except OFF.

(13) Measure voltage at E-terminals in list below. Handset may be used to key RT.

Test	Relay	1A31 E-Ter- minal	Voltage Indications		For Reference Only Module Pin Location
			Unkeyed	Keyed	
5	A2K1	E70	0 V dc	-5V dc ±0.3	14
6	A2K2	E71	0 V dc	+ 10V dc ±0.3	10
7	A2K2	E72	0 V dc	+ 24V dc ±0.5	13, 16, 17
8	A5K1 (PS Fil- ter in XMT Mode)	E-1	24V dc ±1.5	Voltage Change -1 ±0.7V dc	

NOTE

Relay 1A1A2A1K1 is activated when keyed in all power modes except OFF and RCV ONLY.

(14) Set POWER control to LO PWR. Measure and record voltages at E-terminals for each circuit listed below:

Test	1A1A2A1K1 Circuit	1A1A31 E-Ter- minal	Voltage Indications		(For Ref- erence Only) Module 1A2 Pin Location
			Unkeyed	Keyed	
9	RT-55	E61	-5 V dc ±0.3	+ 5 V dc ±0.3	12
10	TR-55	E62	+ 5V dc ±0.3	-5V dc ±0.3	12

(15) If any tests 1 through 10 fail, refer to list below for module replacement.

Failed Test	Replace Module
1	1A1A5
2	1A1A4
3	1A1A4
4	1A1A4
5	1A1A2
6	1A1A2
7	1A1A2
8	1A1A5
9	1A1A2
10	1A1A2

b. Receive Synthesizer Troubleshooting Tests. There are six separate test groups that comprise the synthesizer tests. These tests are conducted individually as shown on the simplified synthesizer troubleshooting diagram in figure 4-12 and are discussed in the following paragraphs. The test

point locations for these tests are shown in figure 4-13.

(1) *Pump VFO 1A1A18 troubleshooting tests.*

(a) Set up test equipment as shown in figure 4-14 setup (A).

(b) Set RT FREQUENCY and MODE controls as indicated below.

(c) Check Pump VFO 1A1A8 frequency and signal level at test points indicated.

(d) Test point locations are shown in figure 4-13. The troubleshooting flow diagram is shown in figure 4-15.

(e) Set up test equipment as shown in figure 4-11 setup (B).

(f) Check Phase Detector 1A1A8 output level.

Module	Test Point	RT Freq.	Model	Test Freq.	Level
Pump VFO 1A1A18	P2 W5A13P1	2.150 MHz	AM	113.605 ±5 kHz	> -2 dBm
	P1 W4A6A2P1	2.150 MHz	AM	113.605 ±5 kHz	> + 1 dBm
Phase Detector 1A1A8	TP1	2.150 MHz	AM		> + 3Vdc
	TP2	2.150 MHz	AM		+ 16 ±0.75V dc

(2) *Translator 1A1A6 troubleshooting tests.*

(a) Set up test equipment as shown in figure 4-16.

(b) Set RT FREQUENCY and MODE control as indicated below.

(c) Check Translator 1A1A6 input and output frequency and signal level at test points indicated.

(d) Test point locations are shown in figure 4-13. The troubleshooting flow diagram is shown in figure 4-17.

Module	Test Point	RT Freq.	Mode	Test Freq.	Level
Translator 1A1A6 Input	Signal Gen. into W3 Cable (Pump Term)	2.150 MHz	AM	113.605 MHz	+ 1 dBm
Translator 1A1A6 Output	W2 Cable into Counter- voltmeter	2.150 MHz	AM	8,800 MHz ±5 kHz	> -7 dBm

NOTE

The correct Translator output frequency is 6.7 MHz plus the RT dial frequency in 100 kHz increments ±5 kHz.

(3) *Second Mixer 1A1A16 troubleshooting tests.*

(a) Set up test equipment as shown in figure 4-18.

(b) Set RT FREQUENCY and MODE controls as indicated below.

(c) Check Second Mixer 1A1A16 output level at test point indicated.

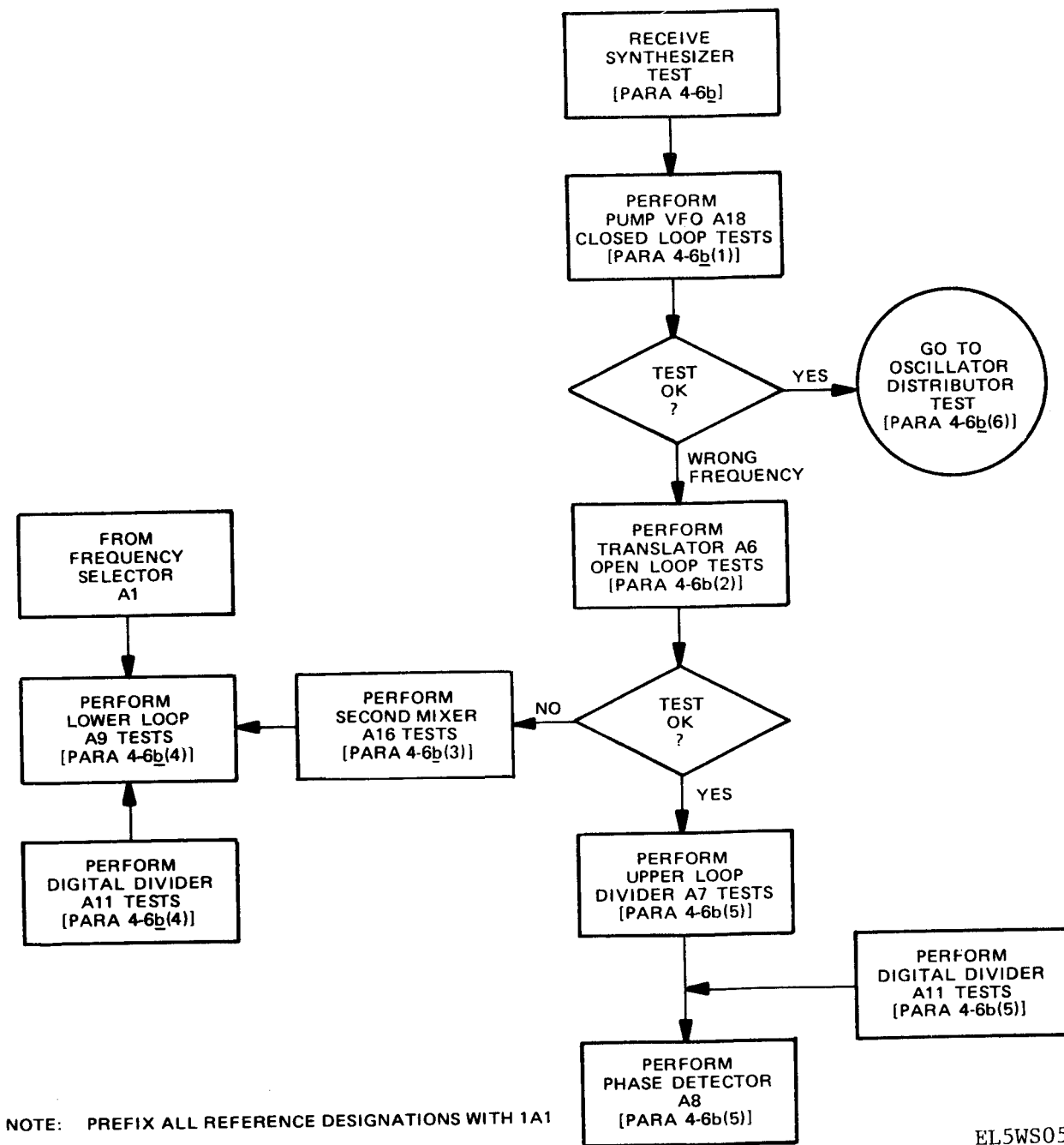

Figure 4-12. Synthesizer troubleshooting diagram.

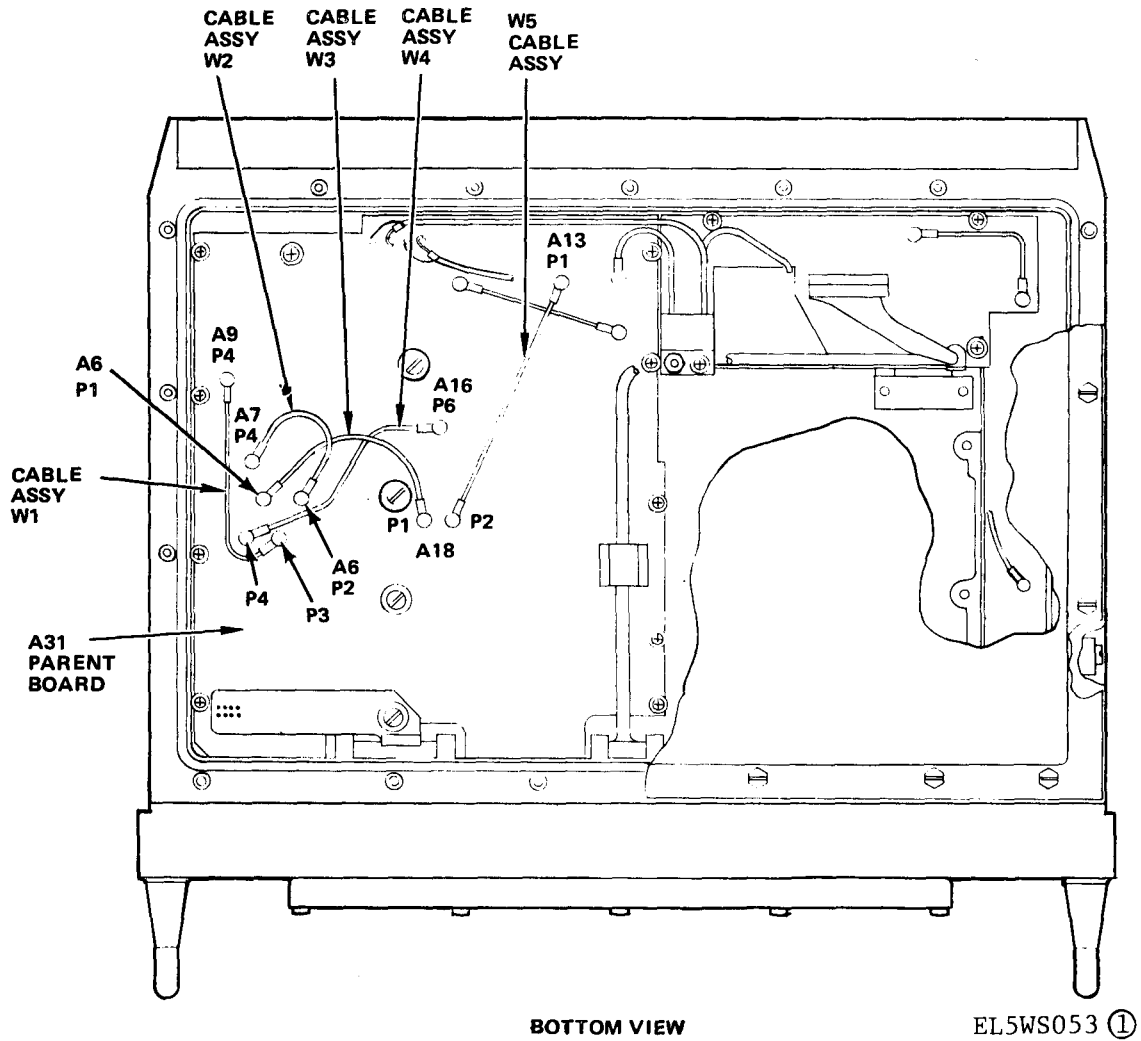
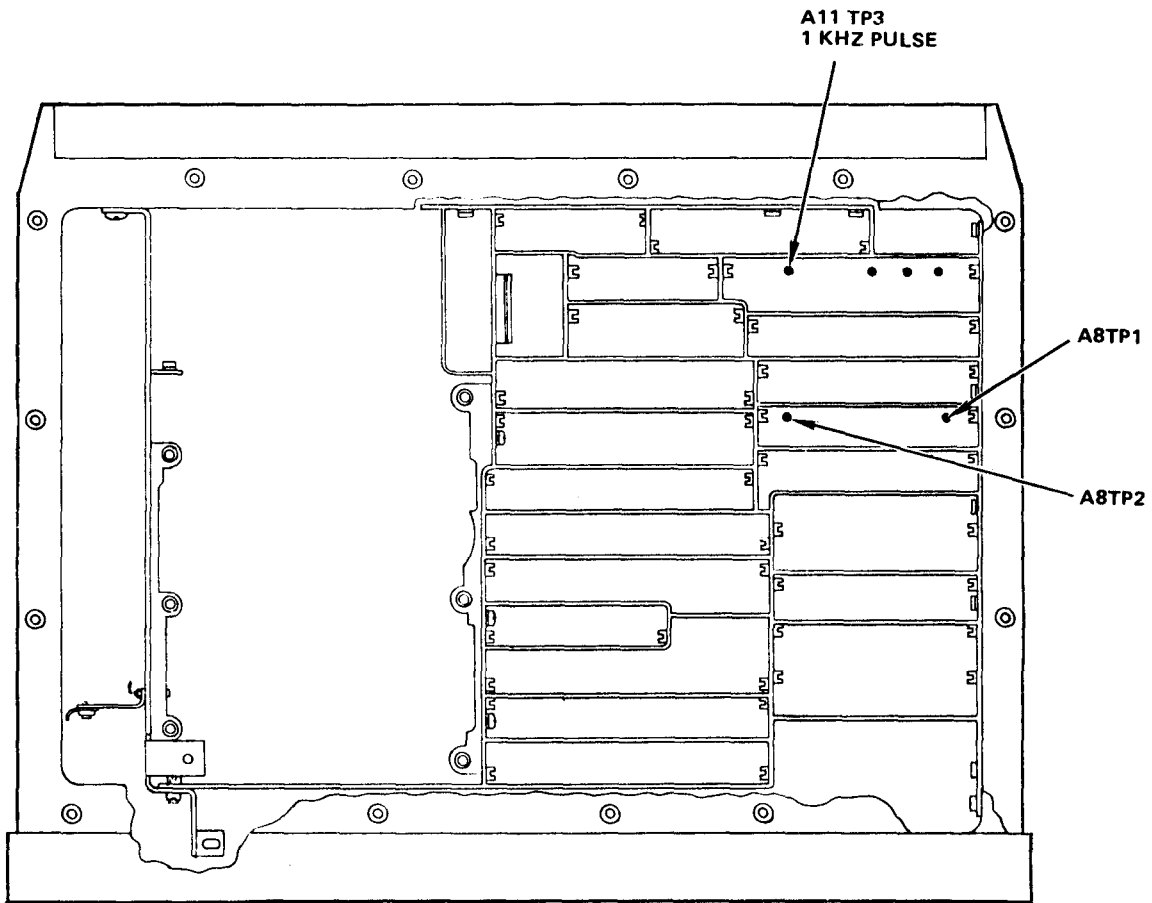
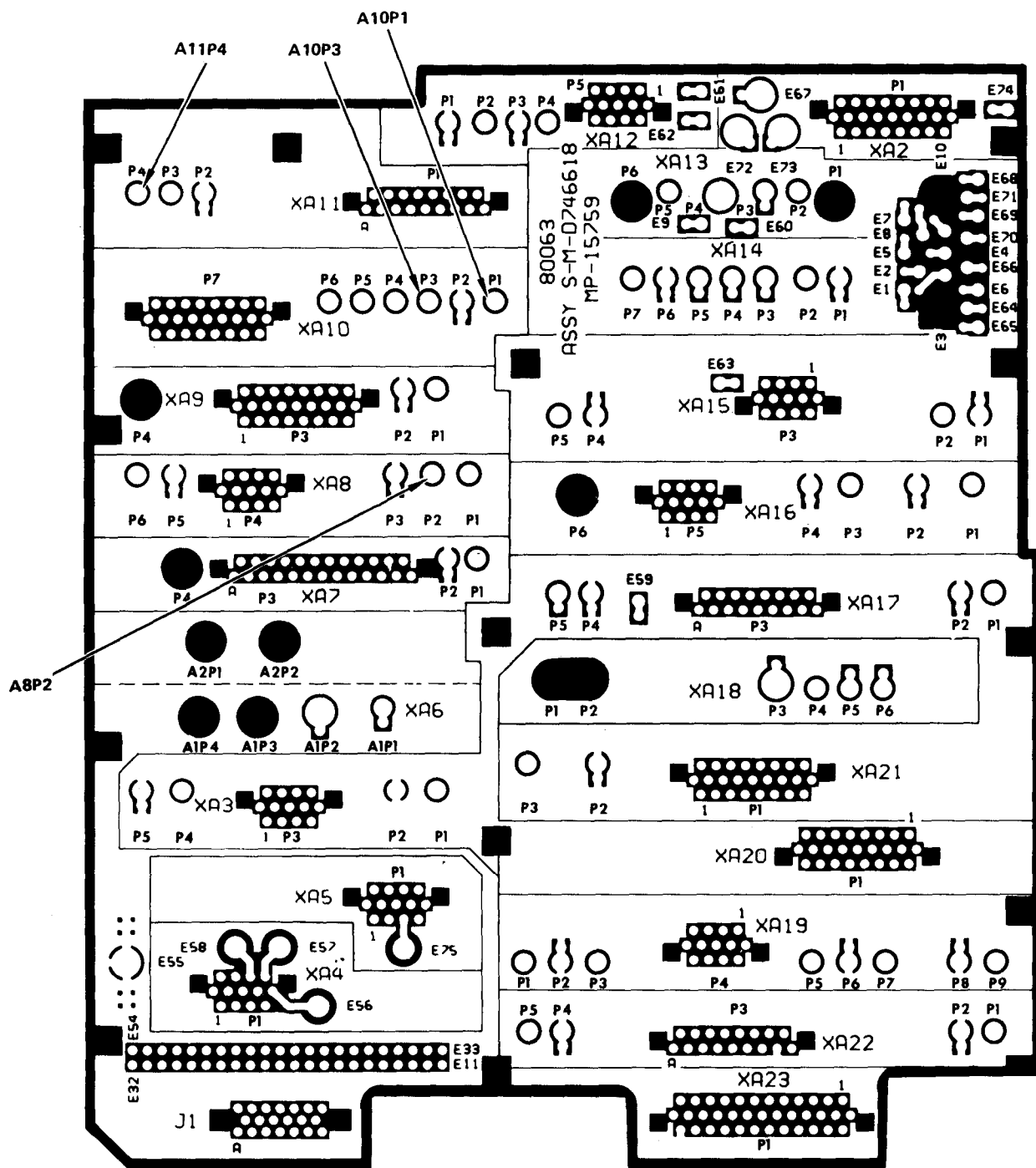

Figure 4-13. Synthesizer test points locations (sheet 1 of 3).



EL5WS053 ②

Figure 4-13. Synthesizer test points locations (sheet 2 of 3).



EL5WS053 ③

Figure 4-13. Synthesizer test points locations (sheet 3 of 3).

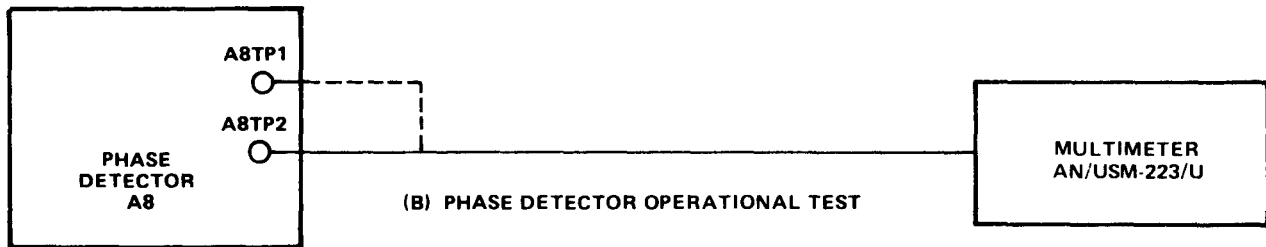
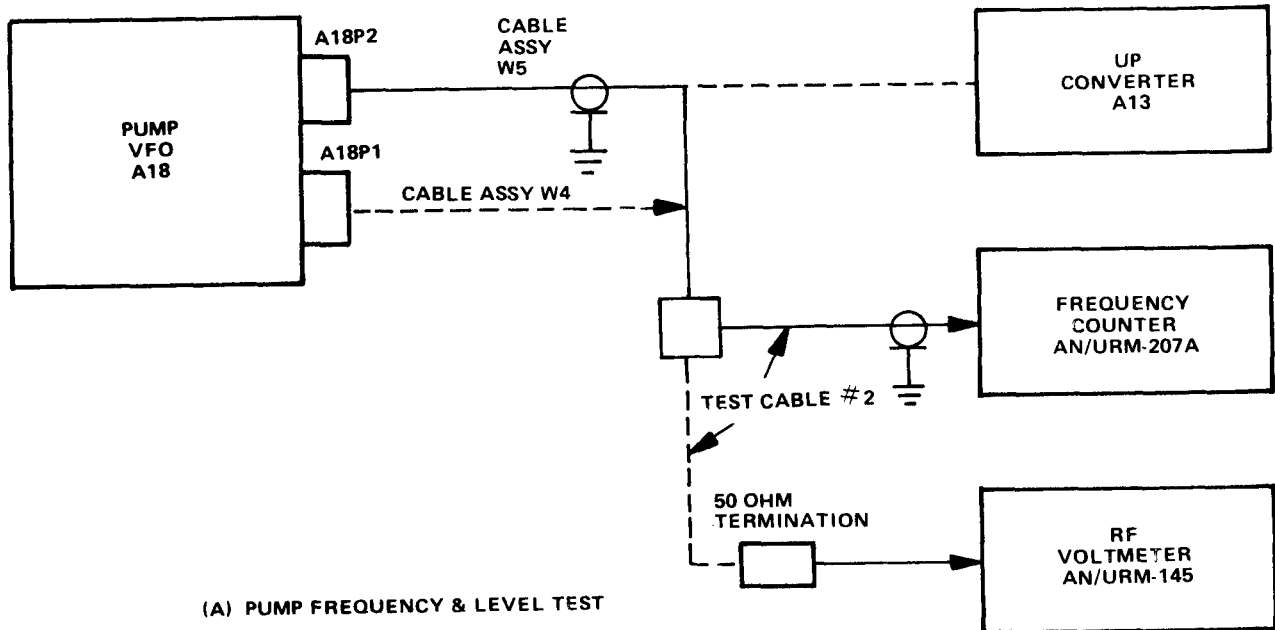

NOTE: PREFIX ALL REFERENCE DESIGNATIONS WITH 1A1

EL5WS054

Figure 4-14. Pump VFO 1A1A18 test setup.

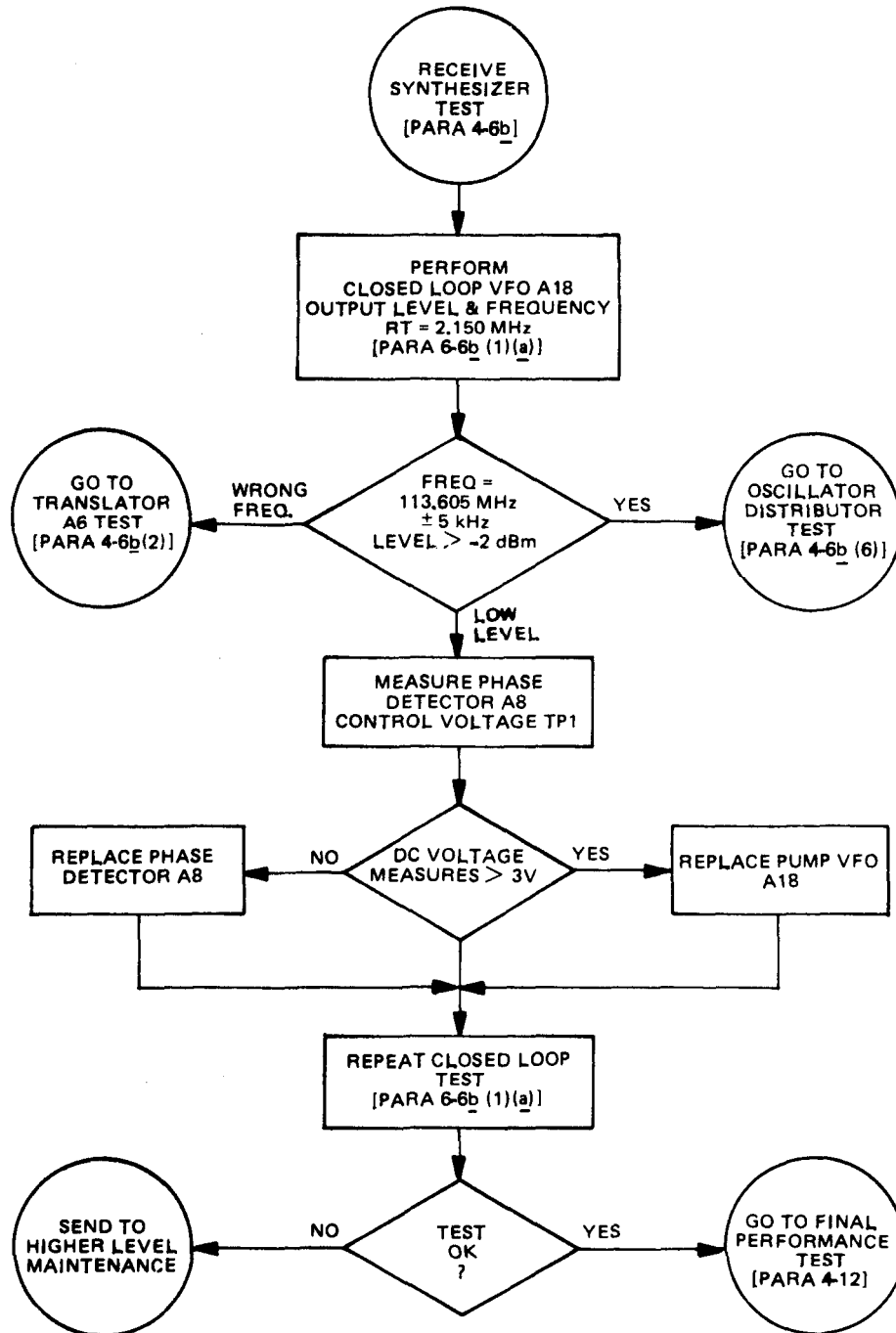

NOTE: PREFIX ALL REFERENCE DESIGNATIONS WITH 1A1

EL5WS055

Figure 4-15. Pump VFO 1A1A18 troubleshooting diagram.

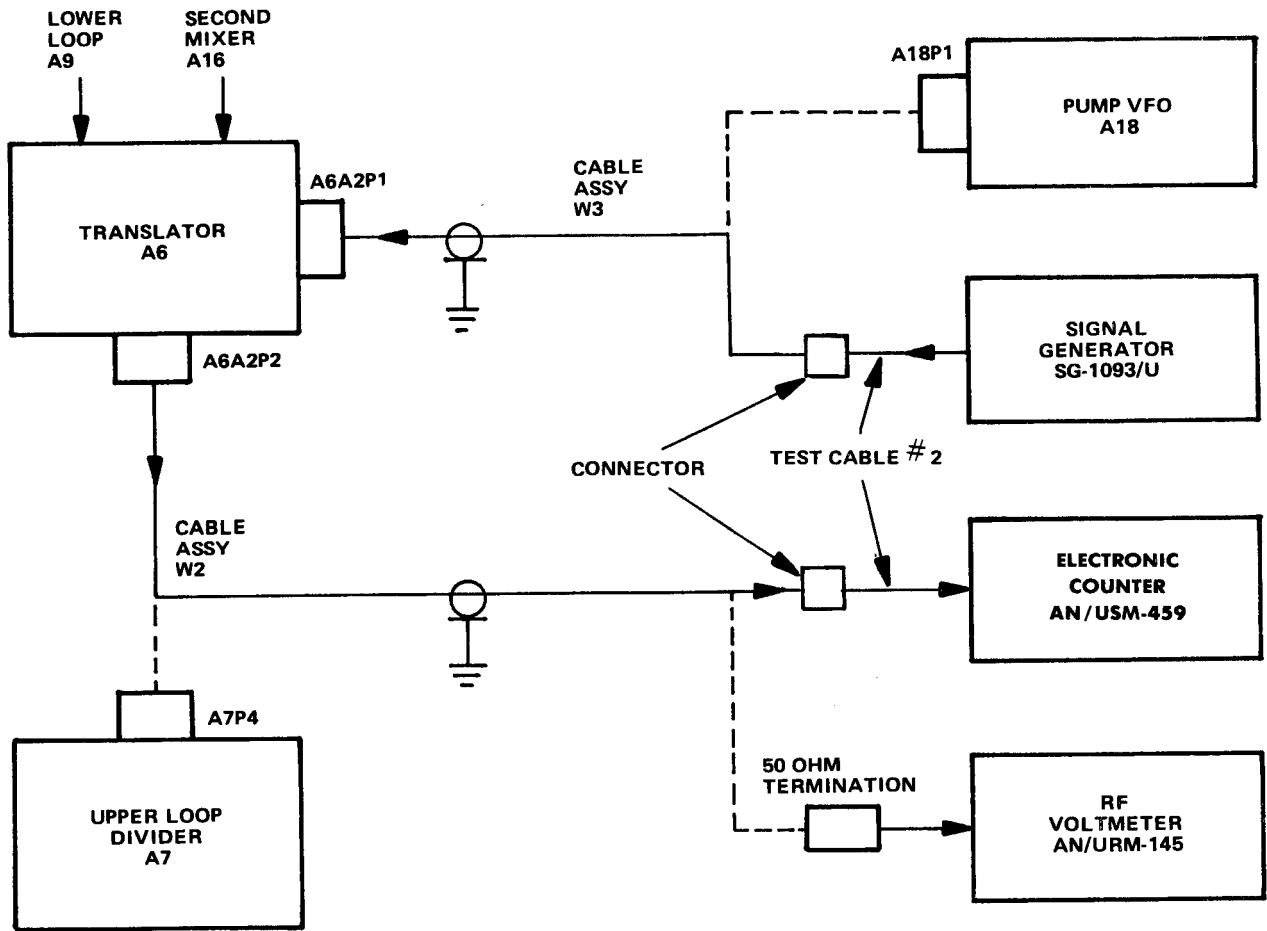

NOTE: PREFIX ALL REFERENCE DESIGNATIONS WITH 1A1

EL5WS056

Figure 4-16. Translator 1A1A6 test setup.

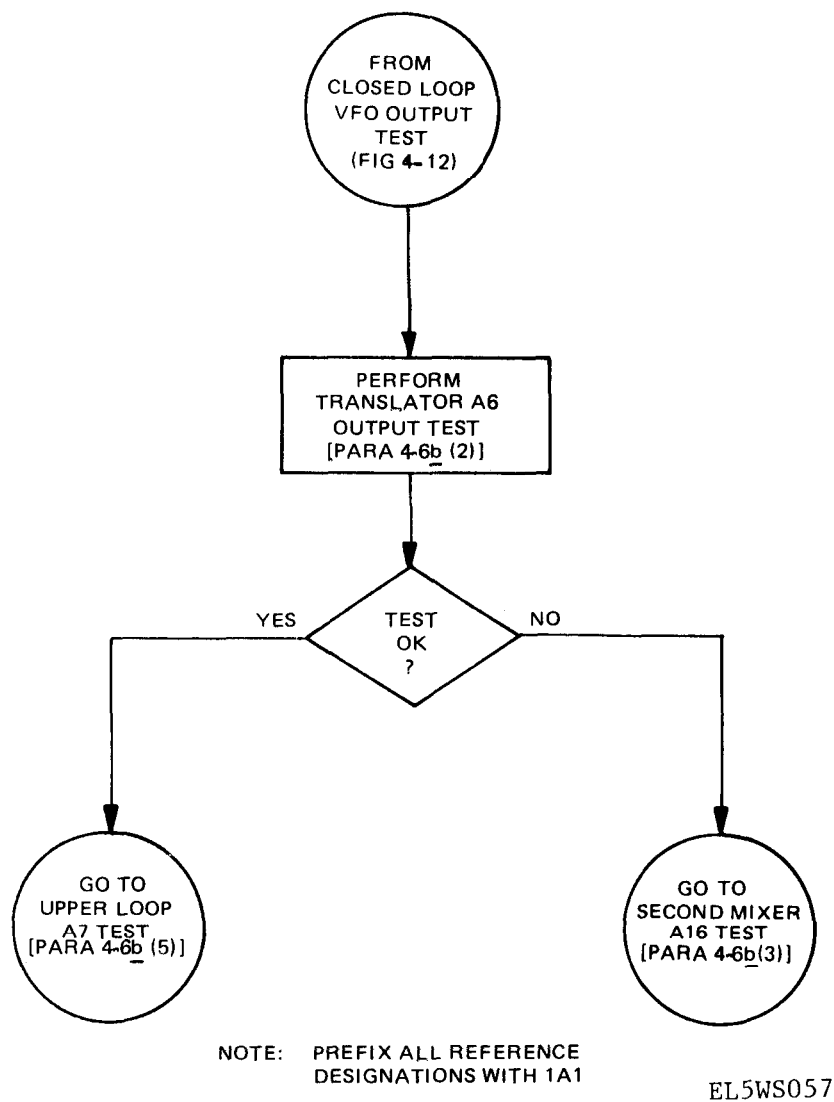
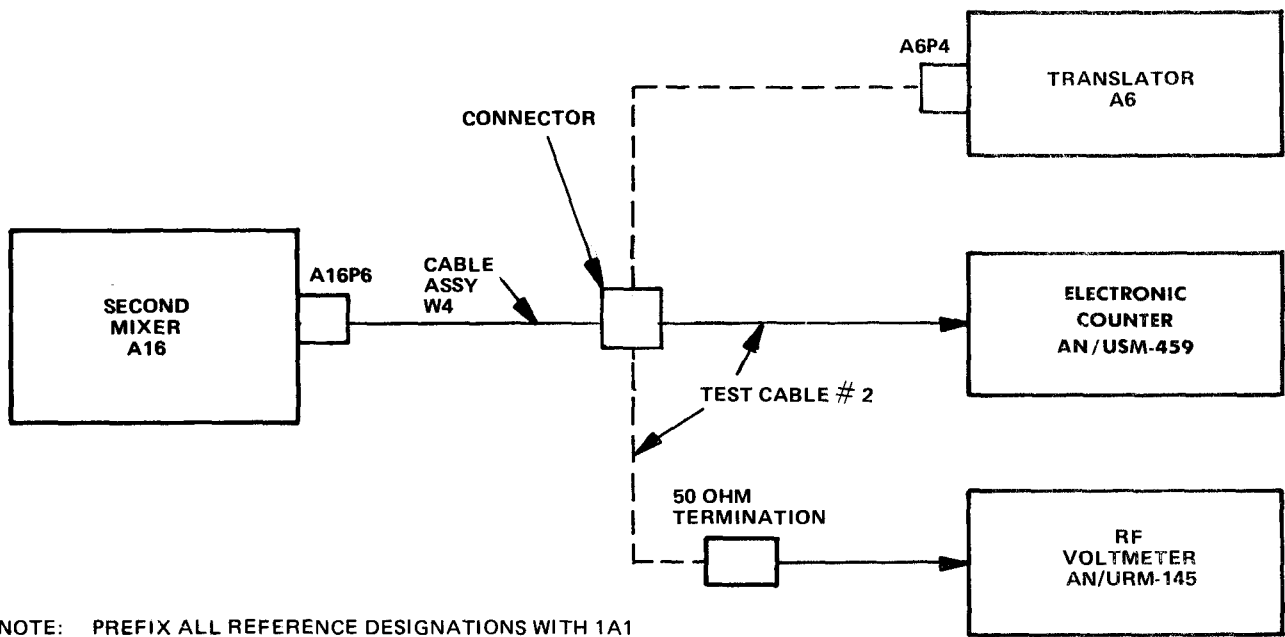

Figure 4-17. Translator 1A1A6 troubleshooting diagram.



NOTE: PREFIX ALL REFERENCE DESIGNATIONS WITH 1A1

EL5WS058

Figure 4-18. Second mixer 1A1A16 test setup.

(d) Test point locations are shown in figure 4-13. The troubleshooting flow diagram is shown in figure 4-19.

Module	Test Point	RT Freq.	Mode	Test Freq.	Level
2nd Mix 1A1A16	Cable Assy W4	2.150 MHz	AM	100 MHz ±3 kHz	> -10 dBm

- (4) Lower Loop 1A1A9 troubleshooting tests.
- (a) Set up test equipment as shown in figure 4-20.
 - (b) Set RF FREQUENCY and MODE controls as indicated below.
 - (c) Check frequencies and output levels at test points indicated.

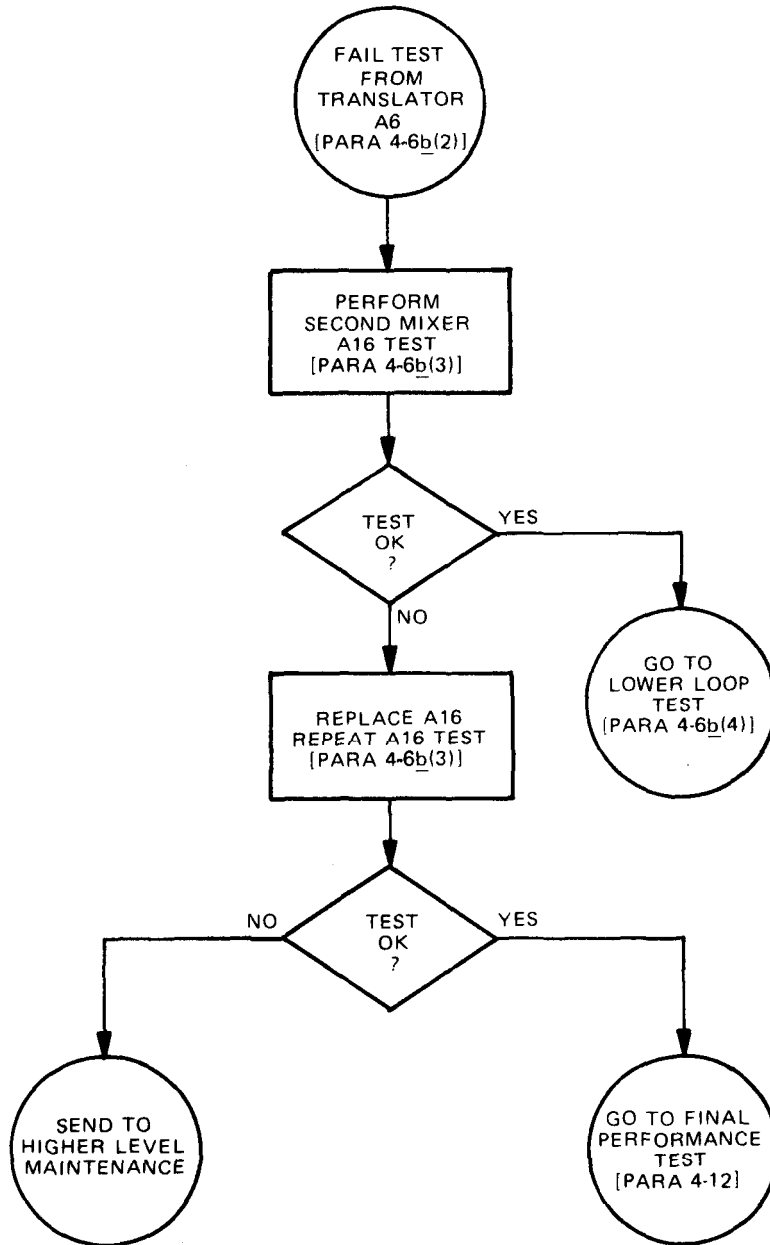

NOTE: PREFIX ALL REFERENCE DESIGNATIONS WITH 1A1

EL5WS059

Figure 4-19. Second mixer 1A1A16 troubleshooting diagram.

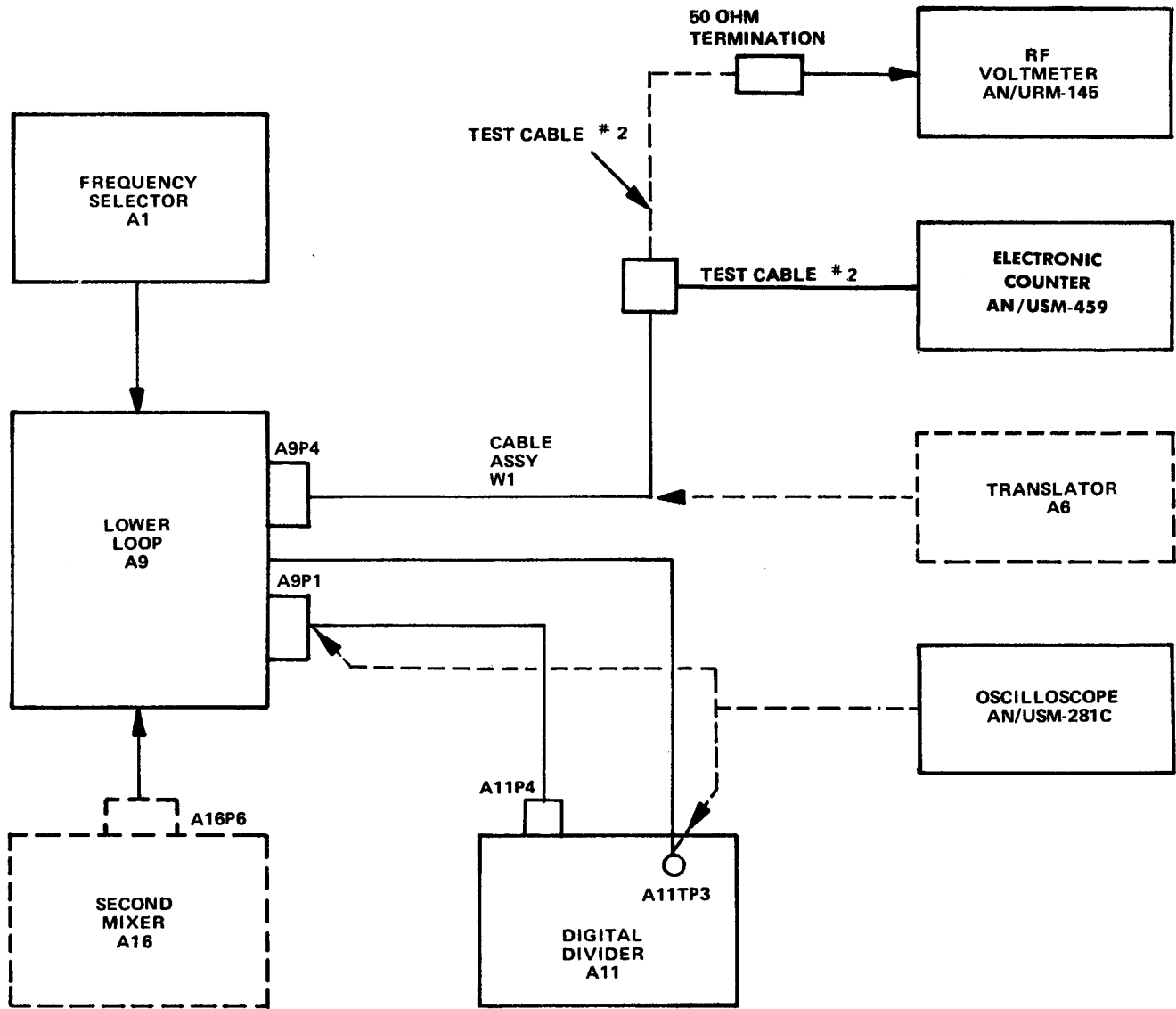

NOTE: PREFIX ALL REFERENCE DESIGNATIONS WITH 1A1

EL5WS060

Figure 4-20. Lower loop 1A1A9 test setup.

(d) Test point locations are shown in figure 4-13. The troubleshooting flow diagram is shown in figure 4-21.

Module	Test Point	RT Freq.	Mode	Test Freq.	Level
Lower Loop 1A1A9	Cable Assy W1	2.150 MHz	AM	4.755 MHz >20 Hz	> -12 dBm
Digital Divider 1A1A11	TP3	2.150 MHz	AM	1 kHz Pulse 50% DC	8 to 10V PP
	P4 or A9P1	2.150 MHz	AM	4.5 MHz	200 to 400 mV PP

Freq Selector 1A1A1
Module not tested. Replace after testing all other modules.

(5) Upper Loop Divider 1A1A7 troubleshooting tests.

(a) Set up test equipment as shown in figure 4-22.

(b) Set RT FREQUENCY and MODE controls as indicated below.

(c) Check frequencies and output levels at test points indicated.

(d) Test point locations are shown in figure 4-13. The troubleshooting flow diagram is shown in figure 4-23.

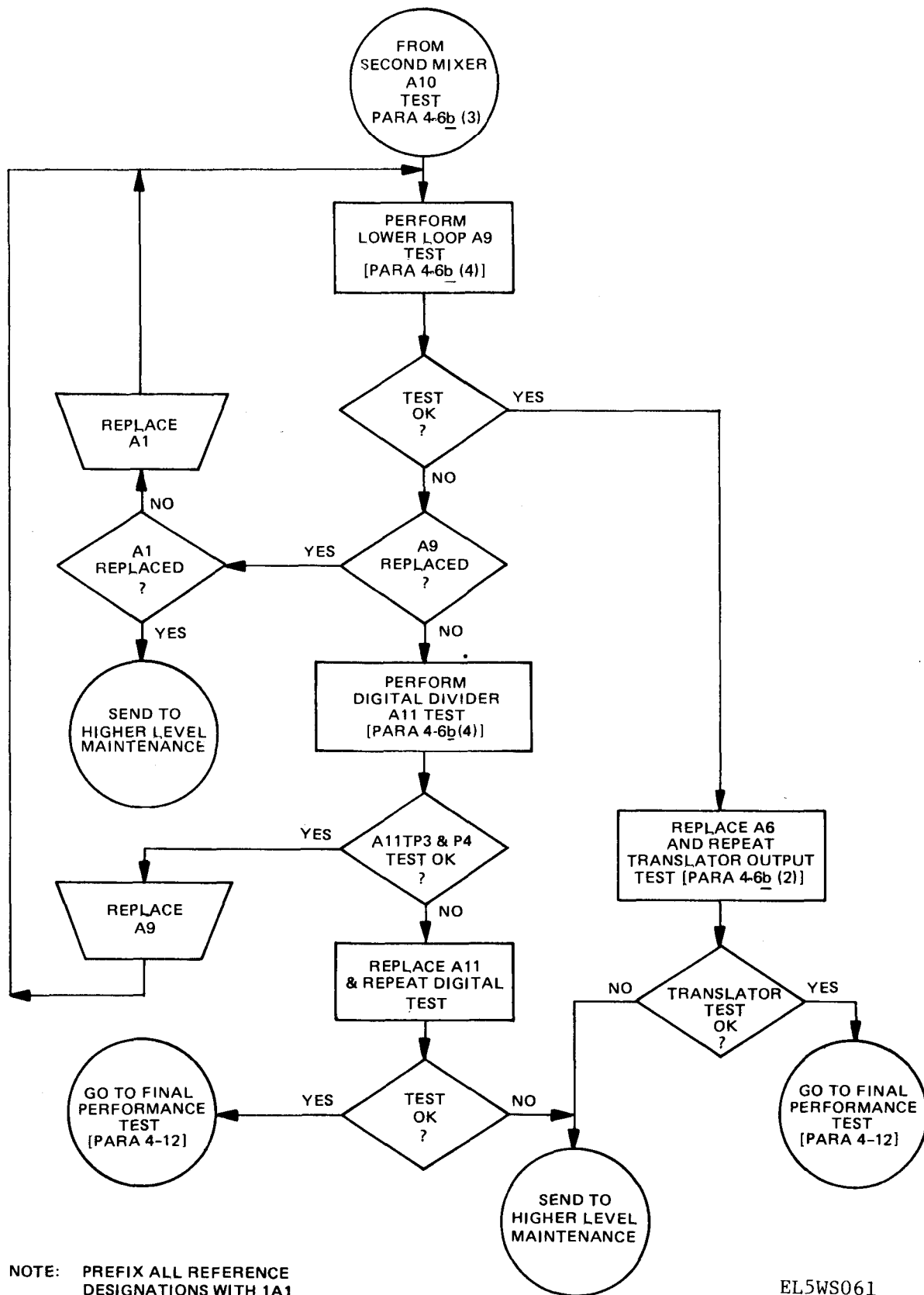
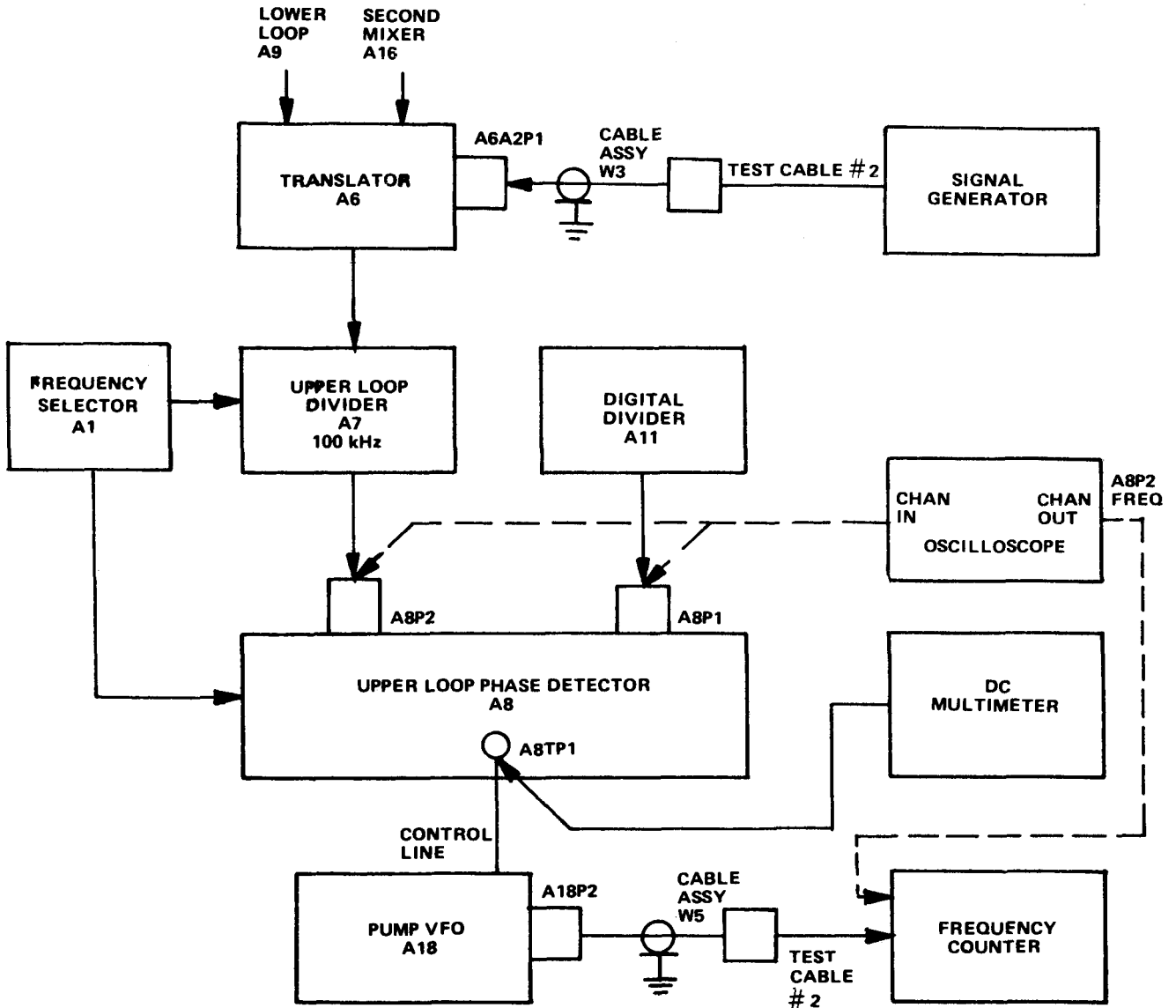

Figure 4-21. Lower loop 1A1A9 troubleshooting diagram.

Module	Test Point	RT Freq.	Mode	Test Freq.	Level	Module	Test Point	RT Freq.	Mode	Test Freq.	Level
Translator 1A1A6 Input	Signal Gen. into W3 Cable (Pump Term)	See table 4-5	AM	See table 4-5	+ 1 dBm	Phase Detec- tor 1A1A8	P2	See table 4-5	AM	100 kHz	3.5 ±1 V
Phase Detec- tor 1A1A8	P1	Any	AM	100 kHz	> 7 VPP					Pulse Width Freq. dependent	
	Source: 1A1A11			µs pulse							



NOTE: PREFIX ALL REFERENCE DESIGNATIONS WITH 1A1

EL5WS062

Figure 4-22. Upper loop divider 1A1A7 test setup.

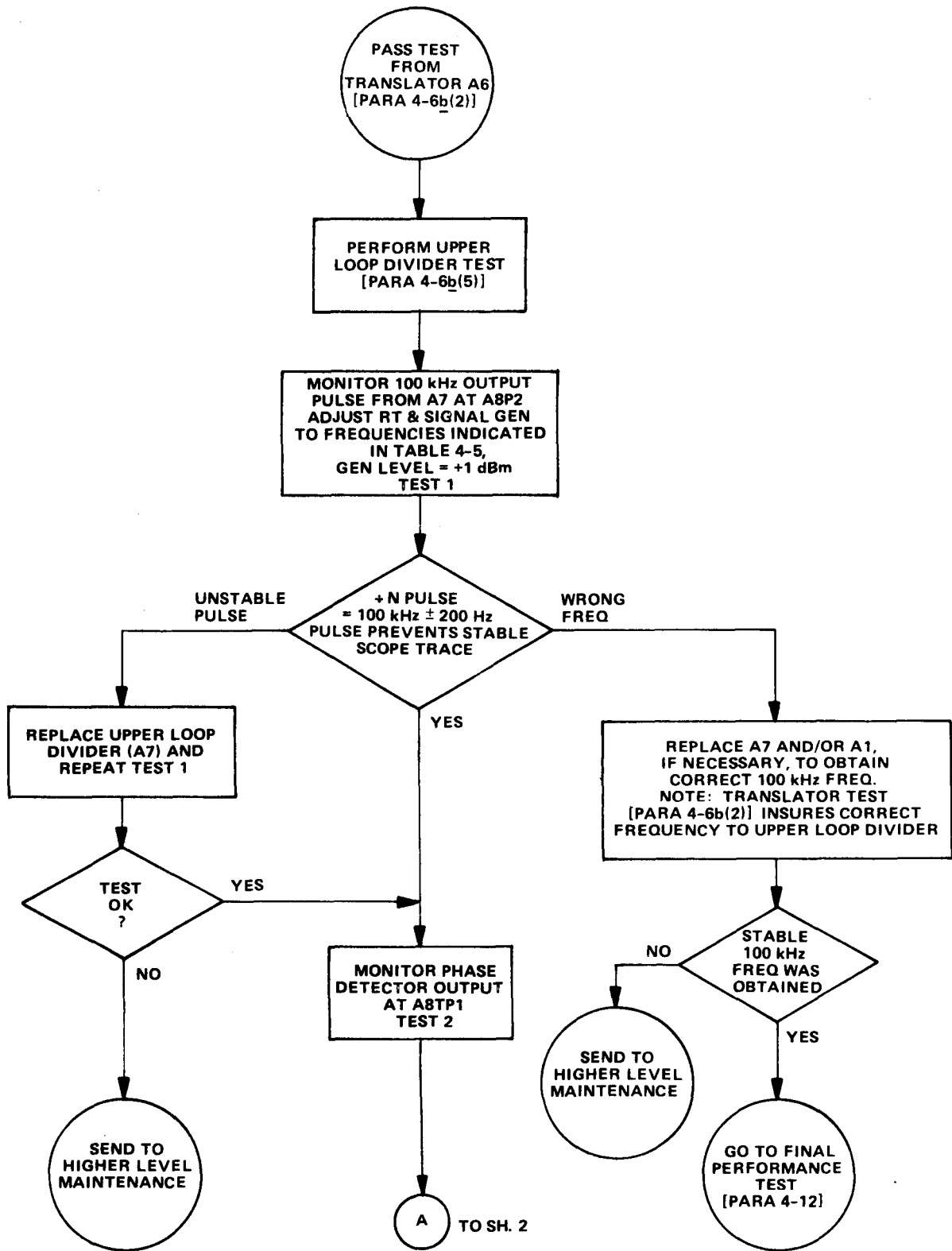

NOTE: PREFIX ALL REFERENCE DESIGNATIONS WITH 1A1

EL5WS063 (1)

Figure 4-23. Upper loop divider 1A1A7 troubleshooting diagram (sheet 1 of 2).

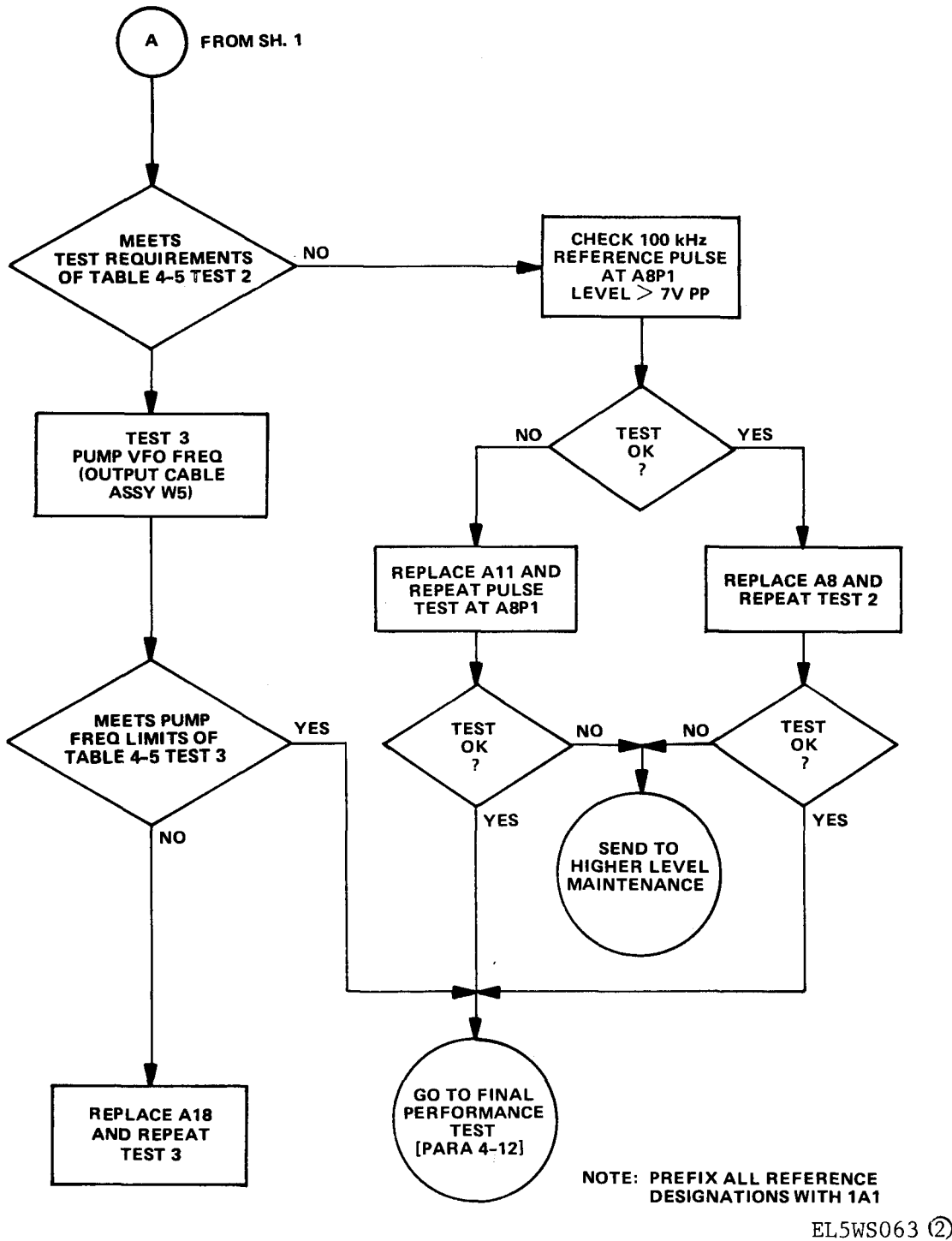
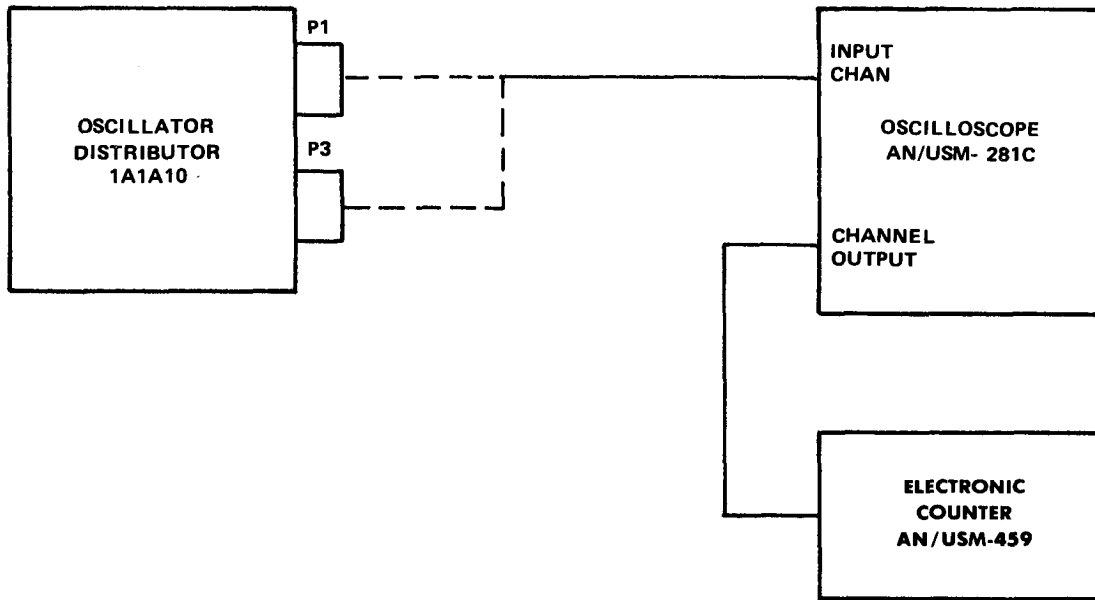

Figure 4-23. Upper loop divider 1A1A7 troubleshooting diagram (sheet 2 of 2).

(6) Oscillator Distributor 1A1A10 troubleshooting tests.

(a) Set up test equipment as shown in figure 4-24.



EL5WS064

Figure 4-24. Oscillator distributor 1A1A10 test setup.

Table 4-5. Upper Loop and Pump Test Limits

RT Freq (MHz)	Signal Generator (MHz)	Test 1	Test 2	Test 3
		Divide by N Pulse Stable? Yes or No	Phase Detector 1A1A8 Output Voltage @ TP1 (V dc)	Pump VFO 1A1A18 (MHz)
2.15	114.000		< 4.1	< 113
	113.605*			
12.15	113.000		> 6.0	> 123
	124.000		< 4.5	< 120
22.15	123.605*			
	123.000		> 6.3	> 133
32.15	134.000		< 5.35	< 130
	133.605*			
42.15	133.000		> 7.5	> 143
	144.000		< 6.1	< 140
52.15	143.605*			
	143.000		> 8.7	> 153
62.15	154.000		< 6.9	< 150
	153.605*			
72.15	153.000		> 9.8	> 163
	164.000		< 7.5	< 160
82.15	163.605*			
	163.000		> 10.8	> 173
92.15	167.000		< 9.2	< 170
	186.605*			
	186.000		> 13.2	> 190

Test paragraph 4-6b(5) 4.

*Phase Detector changes voltage. Signal Generator frequency of ± 5 kHz and divide by N Pulse = 100 kHz only at this frequency.

(b) Set RT FREQUENCY and MODE controls as indicated below.
 (c) Check frequencies and output levels at test points indicated.

(d) Test point locations are shown in figure 4-13. The troubleshooting flow diagram is shown in figure 4-25.

Module	Test Point	RT Freq.	Mode	Test Freq.	Level
1A1A10	P1	2.1500 MHz	AM	11 MHz \pm 50 Hz	> 600 mV p-p
1A1A10	P3	2.1500 MHz	AM	50 kHz \pm 10 Hz	> 2.5 V p-p 50% DC

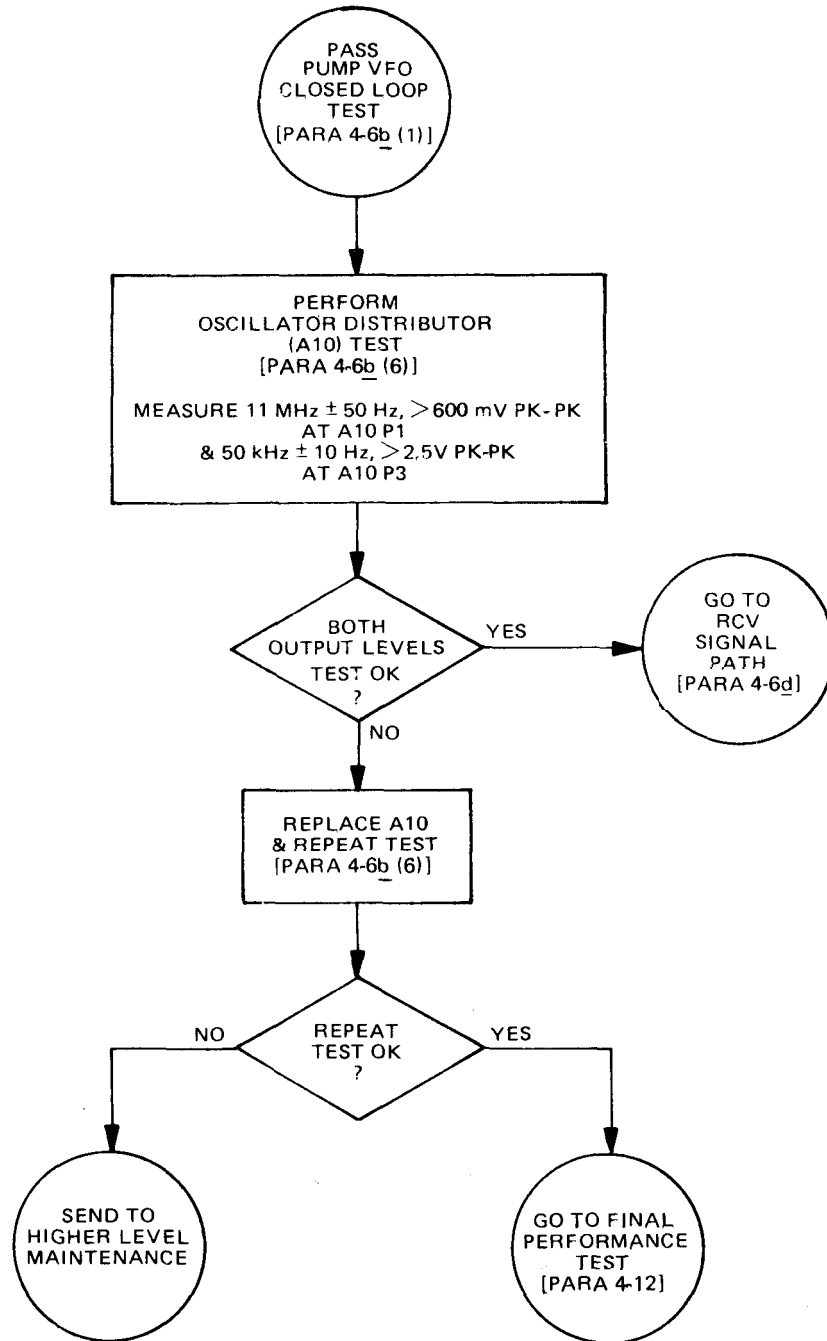

NOTE: PREFIX ALL REFERENCE DESIGNATIONS WITH 1A1

EL5WS065

Figure 4-25. Oscillator distributor 1A1A10 troubleshooting diagram.

c. Mode (RCV) Troubleshooting Tests.
 (1) Preliminary test setup.

(a) Connect test equipment as shown in figure 4-26.

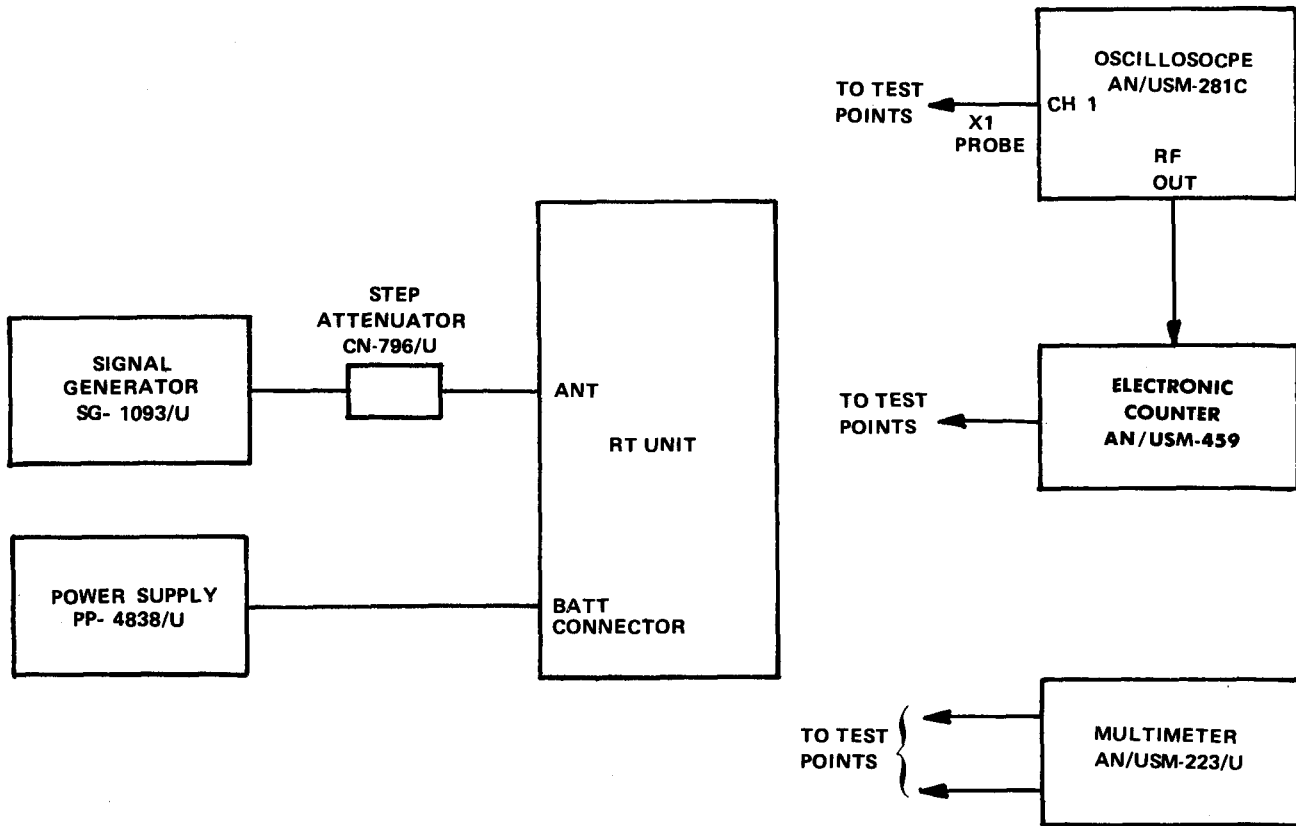

EL5WS066

Figure 4-26. Mode (RCV) test setup.

(b) Set RT controls as follows:

<i>Control</i>	<i>Setting</i>
<i>FREQUENCY</i>	<i>02.1500 MHz</i>
<i>SQUELCH</i>	<i>OFF</i>
<i>POWER</i>	<i>RCV ONLY</i>

(c) Figure 4-27 shows test point location and figure 4-28 shows the troubleshooting flow diagram.

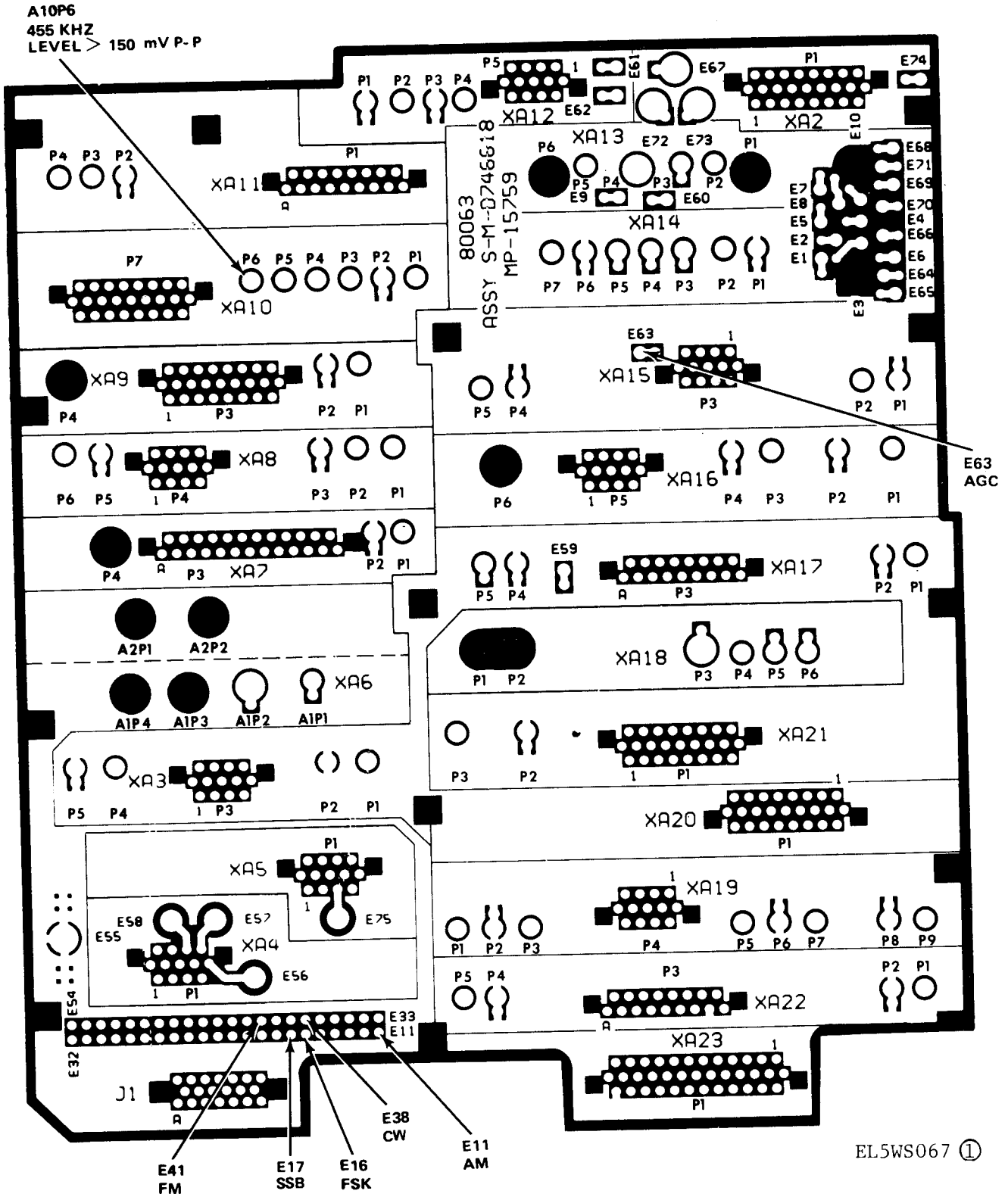

NOTE: PREFIX ALL REFERENCE DESIGNATIONS WITH 1A1A31.

Figure 4-27. Mode (RCV) test point location (sheet 1 of 2).

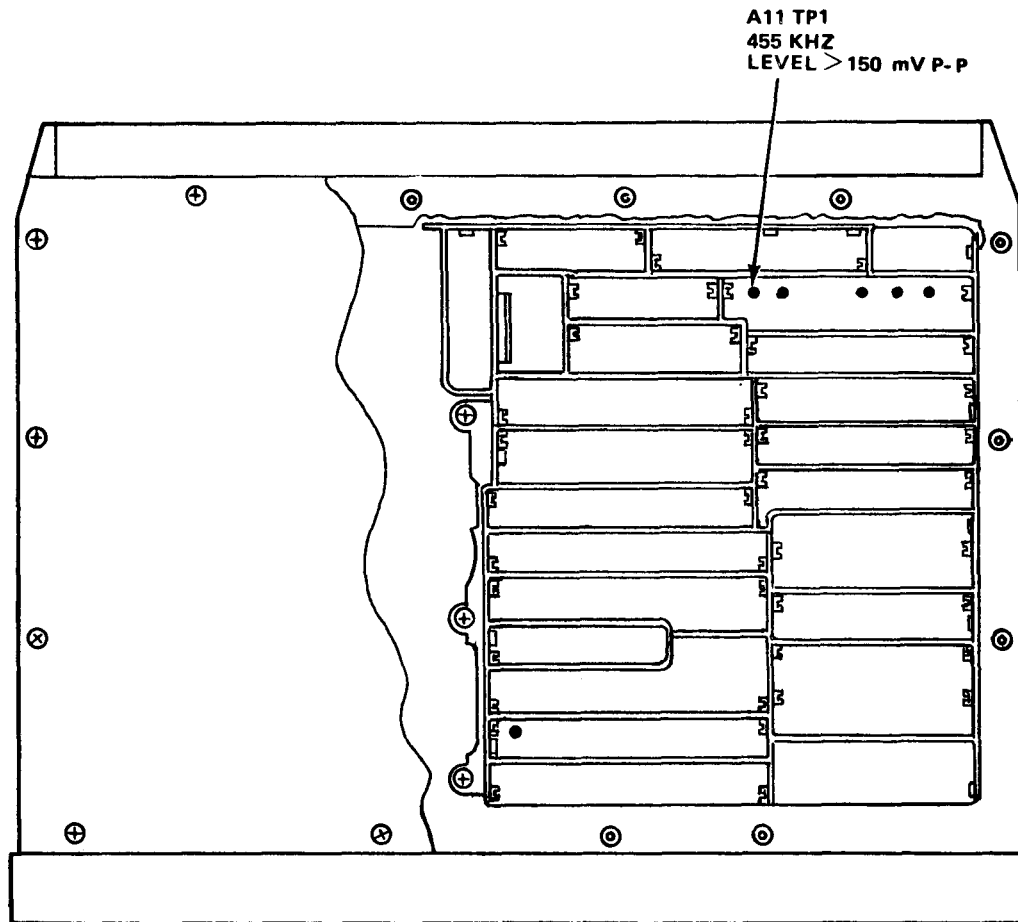

TOP VIEW

EL5WS067 (2)

Figure 4-27. Mode (RCV) test point location (sheet 2 of 2).

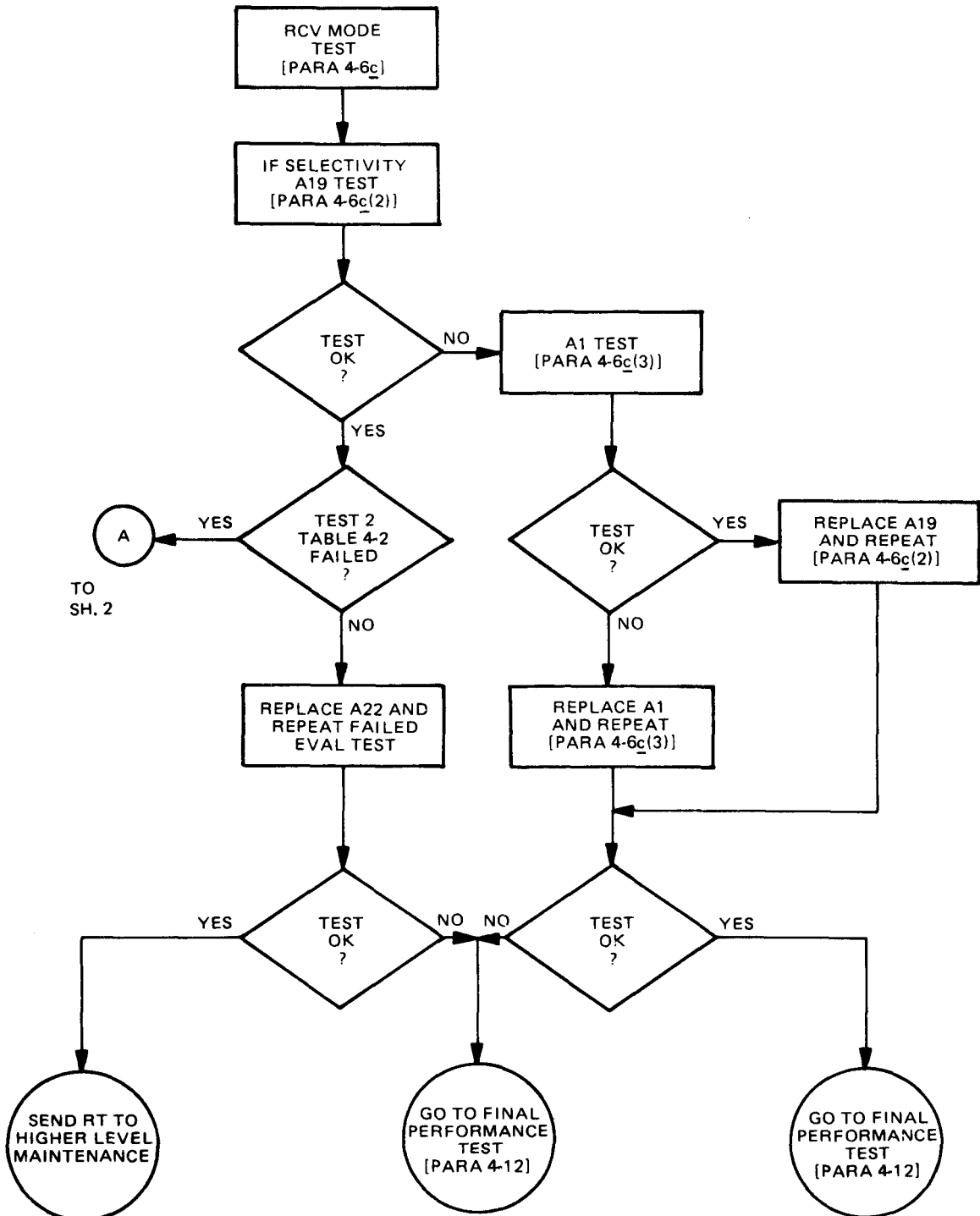

NOTE: PREFIX ALL REFERENCE DESIGNATIONS WITH 1A1.

EL5WS068 (1)

Figure 4-28. Mode (RCV) troubleshooting diagram (sheet 1 of 2).

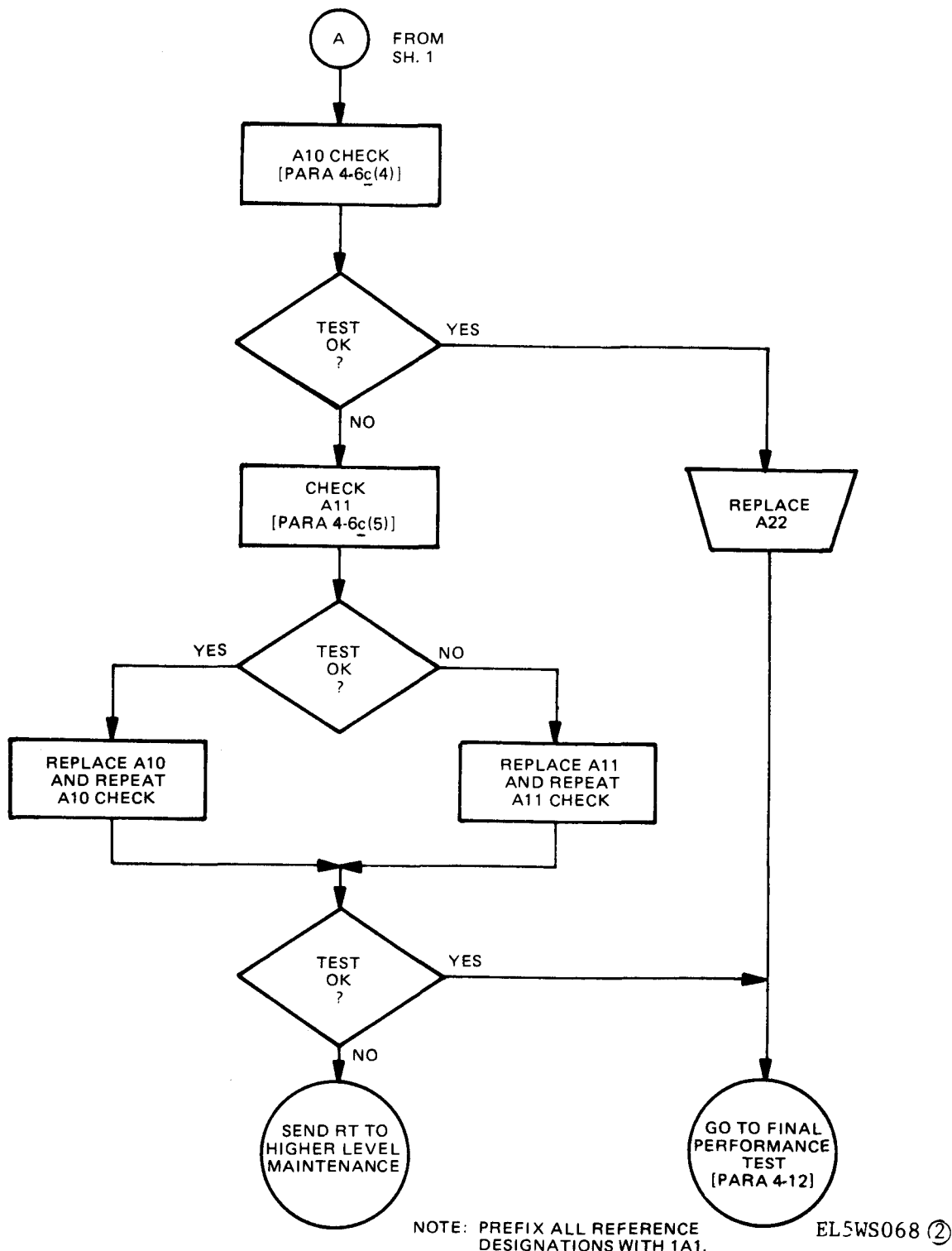

Figure 4-28. Mode (RCV) troubleshooting diagram (sheet 2 of 2).

(2) IF Selectivity 1A1A19 test (AM, FM, SSB filter bandwidth test).

(a) Set RT MODE control to FM.

(b) Set Signal Generator to CW mode and frequency to 2.160 MHz \pm 100 Hz at level of 10 mV into 20 dB pad.

(c) Monitor AGC voltage at 1A1A31E63 with

multimeter with limits of 1 to 5 V dc. Record dc voltage of 2.160 MHz at FM mode for reference for use in step (d).

(d) Set signal generator frequency and RT MODE control as shown below. Check and record change in AGC voltage.

1A1A19 MODE Test

Signal Generator Frequency	Voltage Changes (Limits)		
	FM	AM	SSB
2.160 MHz ±100 Hz	Reference Level	More than + 2 V dc	More than + 2 V dc
2.148 MHz ±100 Hz	Less than ±0.3 V dc	Less than ±0.3 V dc	More than + 2 V dc
2.152 MHz ±100 Hz	Less than ±0.3 V dc	Less than ±0.3 V dc	Less than ±0.3 V dc

(e) If A19 fails the MODE test, perform mode control level check on 1A1A1.

1. If 1A1A1 test passes, replace 1A1A19 and repeat test.

2. If 1A1A1 test fails, replace 1A1A1 and repeat 1A1A19 test.

3. If 1A1A19 test passed and evaluation test 2 of table 4-2 passed, replace 1A1A22 and repeat failed evaluation mode test of table 4-2.

(f) If 1A1A19 test passed and evaluation test 2 of table 4-2 failed, check 1A1A10 and 1A1A11.

(3) *Frequency Selector 1A1A1 test.* Check dc voltage with Multimeter at following E-points on Parent Board 1A1A31 as MODE switch is rotated through its positions.

A1A31 E-Points	MODE - DC Voltages				
	AM	FM	SSB	CW	FSK
11	+5	-5	-5	-5	-5
41	-5	+5	-5	-5	-5
17	-5	-5	+5	-5	-5
38	-5	-5	-5	+5	-5
16	-5	-5	-5	-5	+5

(4) *Oscillator Distributor 1A1A10 check.* Set RT MODE control to failed mode. Check to see that p-p voltage at 1A1A10P6 with X1 Probe is more than 100 mV p-p. Check to see that frequency using Electronic Counter is 455 kHz ±25 Hz.

(5) *Digital Divider 1A1A11 check.*

(a) Using oscilloscope, check to see that p-p voltage at 1A1A11TP1 is more than 150 mV p-p.

(3) Check to see that frequency at 1A1A11TP1 is 455 kHz ±25 Hz.

d. Receive Signal Path Troubleshooting Tests.

(1) *Trouble isolation.*

(a) The following paragraphs, along with the troubleshooting flow diagram shown in figure 4-29, provide procedures to determine what major section of the RT may be defective. When this information is obtained, troubleshooting within the defective section can then be conducted by performing the localized troubleshooting procedures

to determine the next action to be taken. (see fig. FO-2.)

1. Perform Second Mixer 1A1A16 Output Test in accordance with paragraph 4-6d(2)(b) to suggest or eliminate the RF section of the RT as the defective section.

2. If the test results are satisfactory, perform the IF Gain 1A1A3 Output Tests in accordance with paragraph 4-6d(3)(b) to suggest or eliminate the IF section of the RT as the defective section.

3. If the test results are satisfactory, perform the Initial Audio Output Tests in accordance with paragraph 4-6d(4)(b) to suggest or eliminate the audio section of the RT as the defective section.

4. If the test results are unsatisfactory in any of the above tests, perform the detailed troubleshooting procedures within the defective section as indicated in the troubleshooting flow diagram shown in figure 4-29.

(2) *RF/IF signal path test.*

(a) *Initial test setup.*

1. Connect test equipment as shown in figure 4-30.

2. Set RT controls as follows:

Control	Setting
POWER	RCV ONLY
MODE	AM
SQUELCH	OFF
FREQUENCY	02.1500 MHz

3. Set 1A1A2S1 switch to TEST position.

4. Set signal generator to 2.150 MHz ±100 Hz output voltage level to 400 mV CW mode.

5. Refer to figure 4-31 for test point locations and figure 4-32 for troubleshooting flow diagram.

(b) *Second Mixer 1A1A16 output test.*

1. Connect Oscilloscope to 1A1A17P1. Adjust step attenuator to obtain 150 mV peak to peak.

2. Adjust step attenuator to 28 dB ±6 dB.

3. If output is correct perform A3 output test paragraph 4-6d(3)(b).

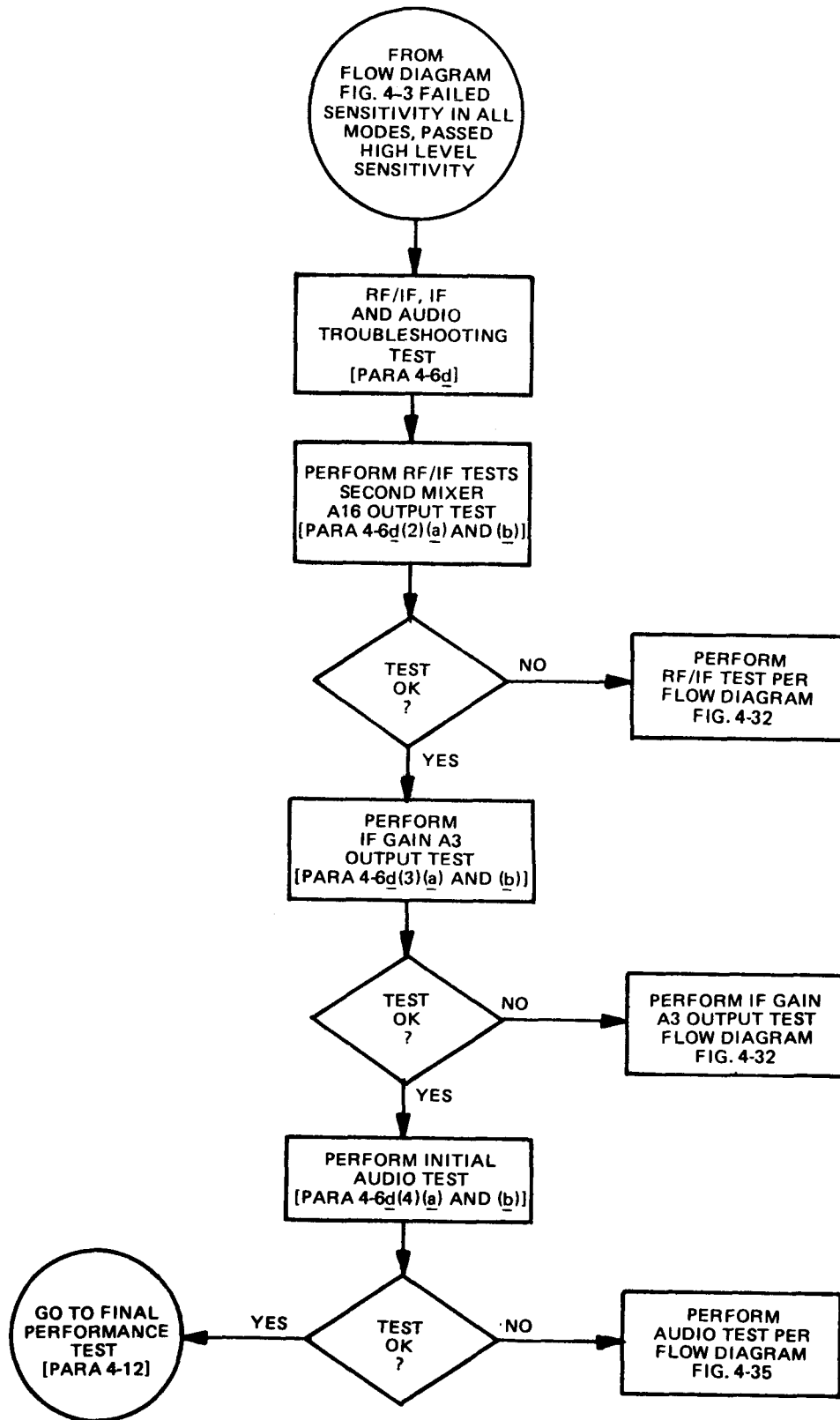

NOTE: PREFIX ALL REFERENCE DESIGNATIONS WITH 1A1

EL5WS069

Figure 4-29. Receive signal path troubleshooting diagram.

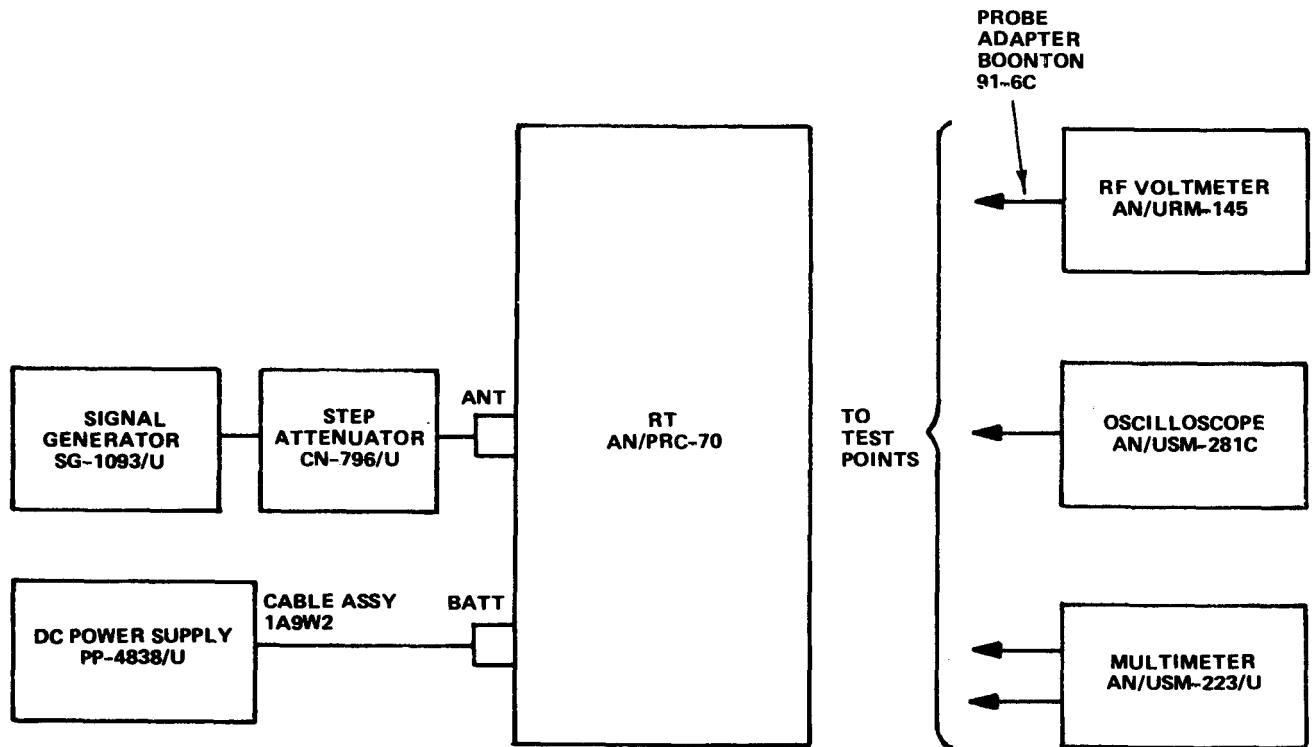

EL5WS070

Figure 4-30. RF/IF signal path test setup.

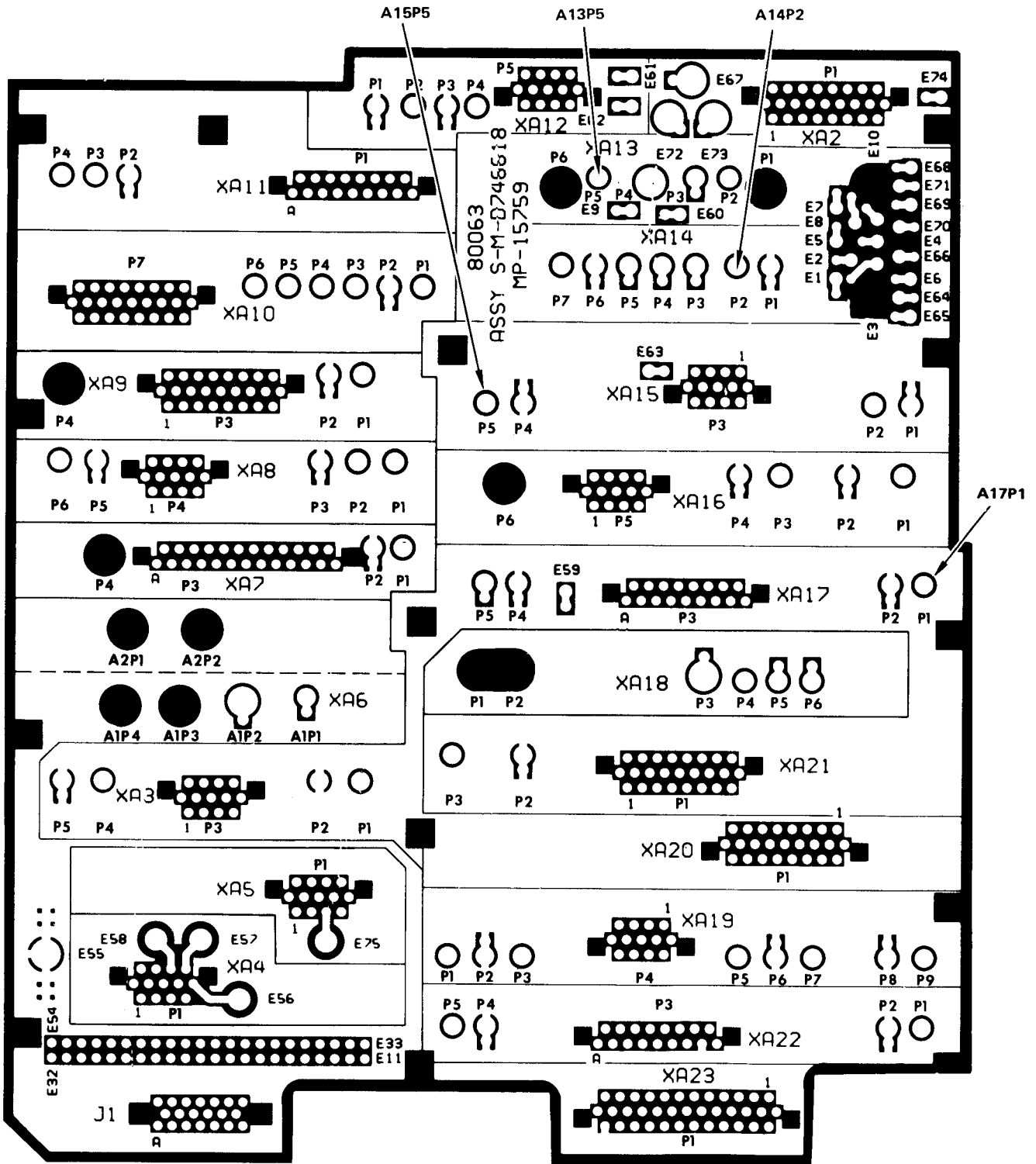

NOTE: PREFIX ALL REFERENCE DESIGNATIONS WITH 1A1A31

EL5WS071 ①

Figure 4-31. RF/IF signal path test point location (sheet 1 of 3).

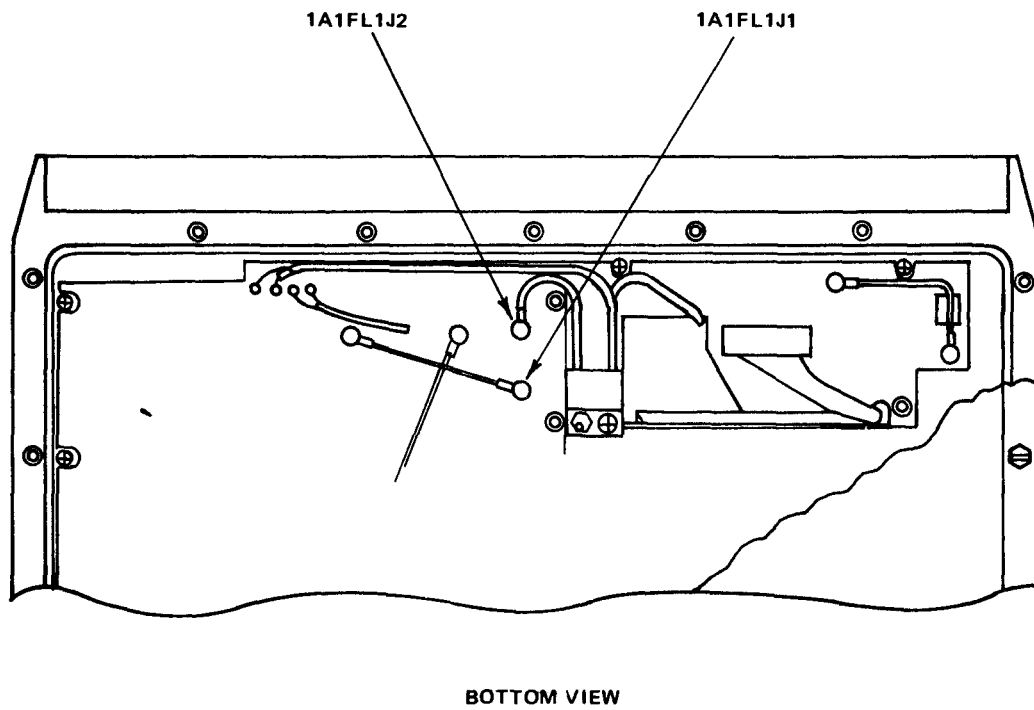

EL5WS071 (2)

Figure 4-31. RF/IF signal path test point location (sheet 2 of 3).

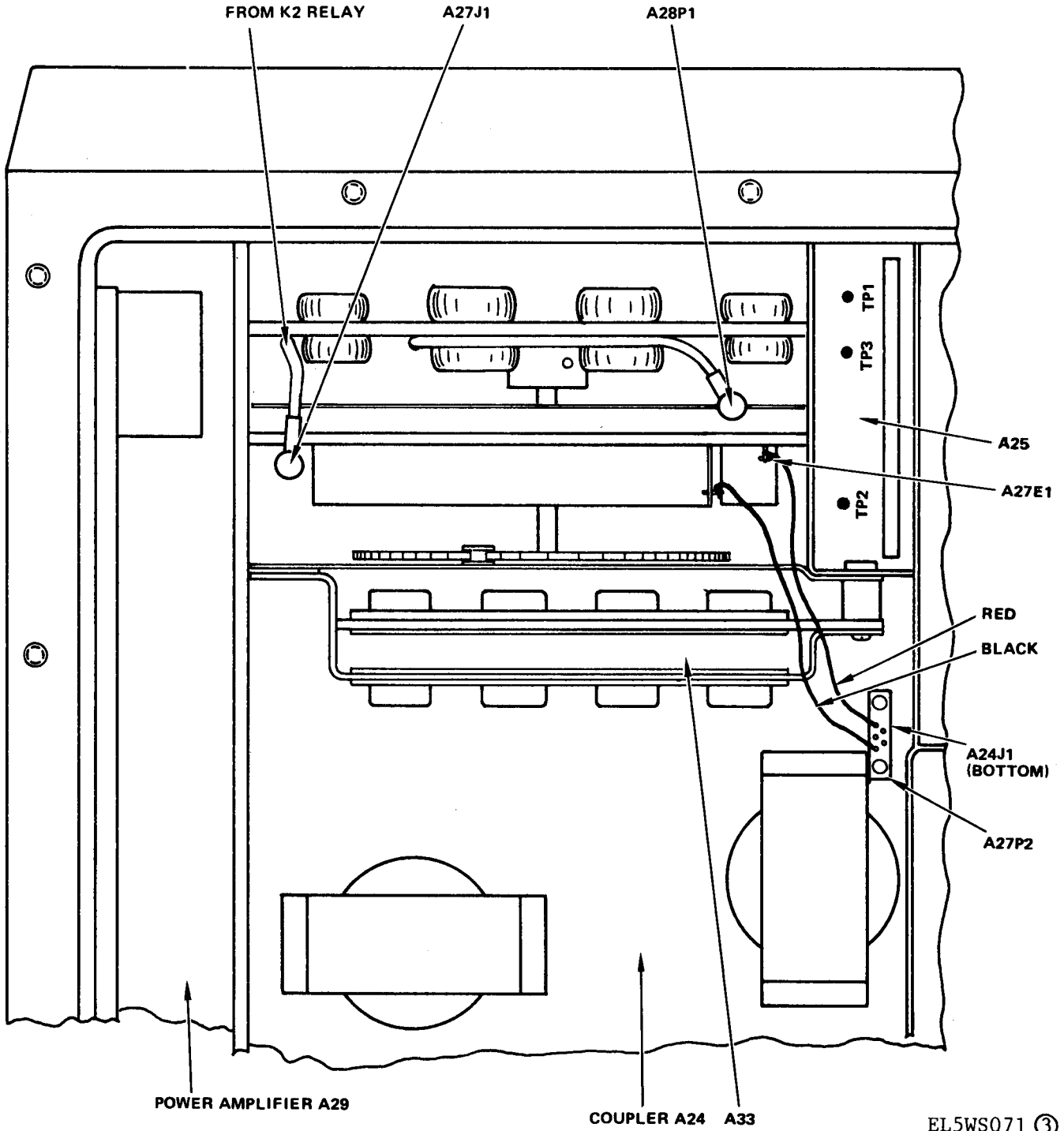

Figure 4-31. RF/IF signal path test point location (sheet 3 of 3).

EL5WS071 ③

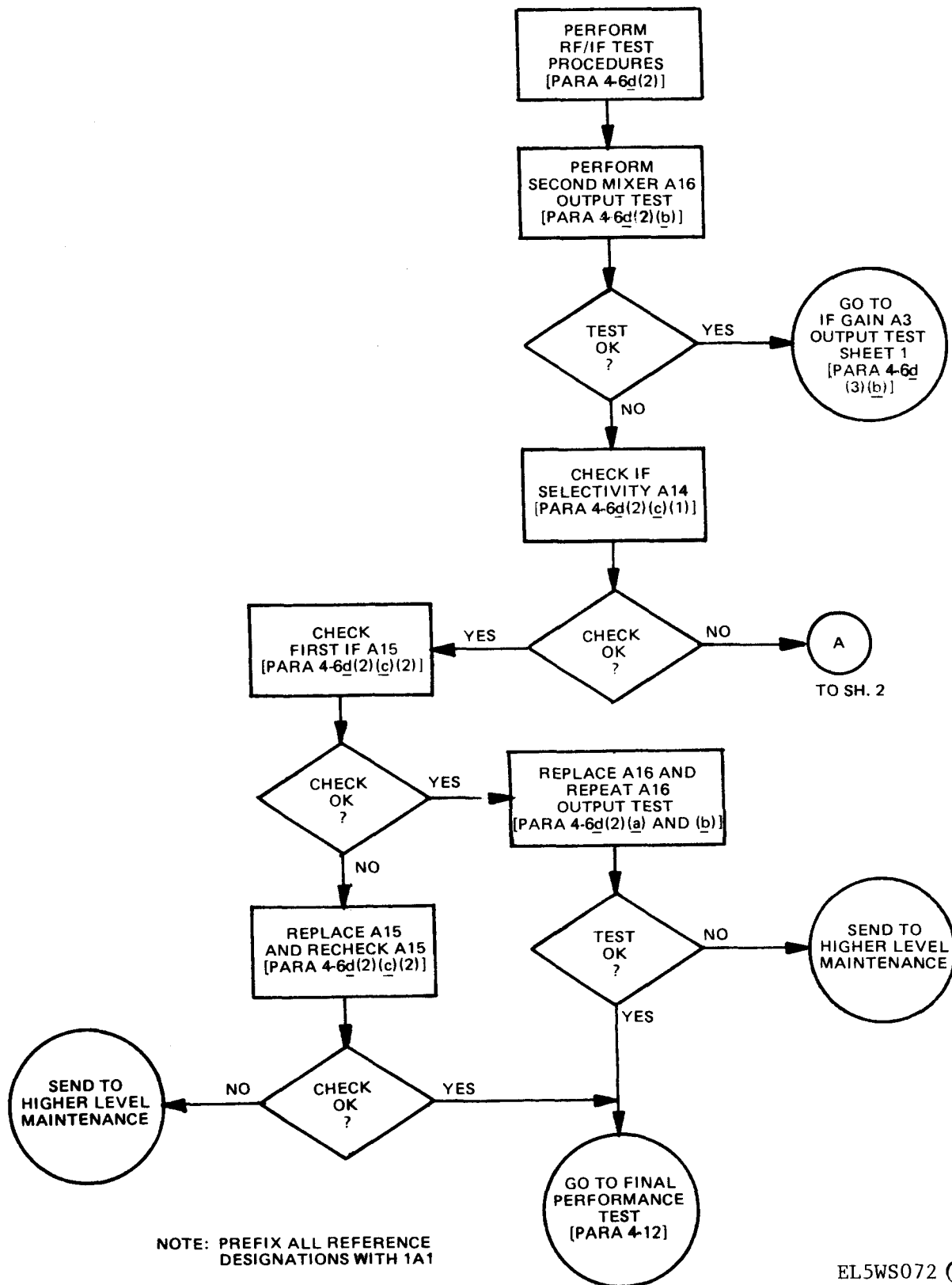
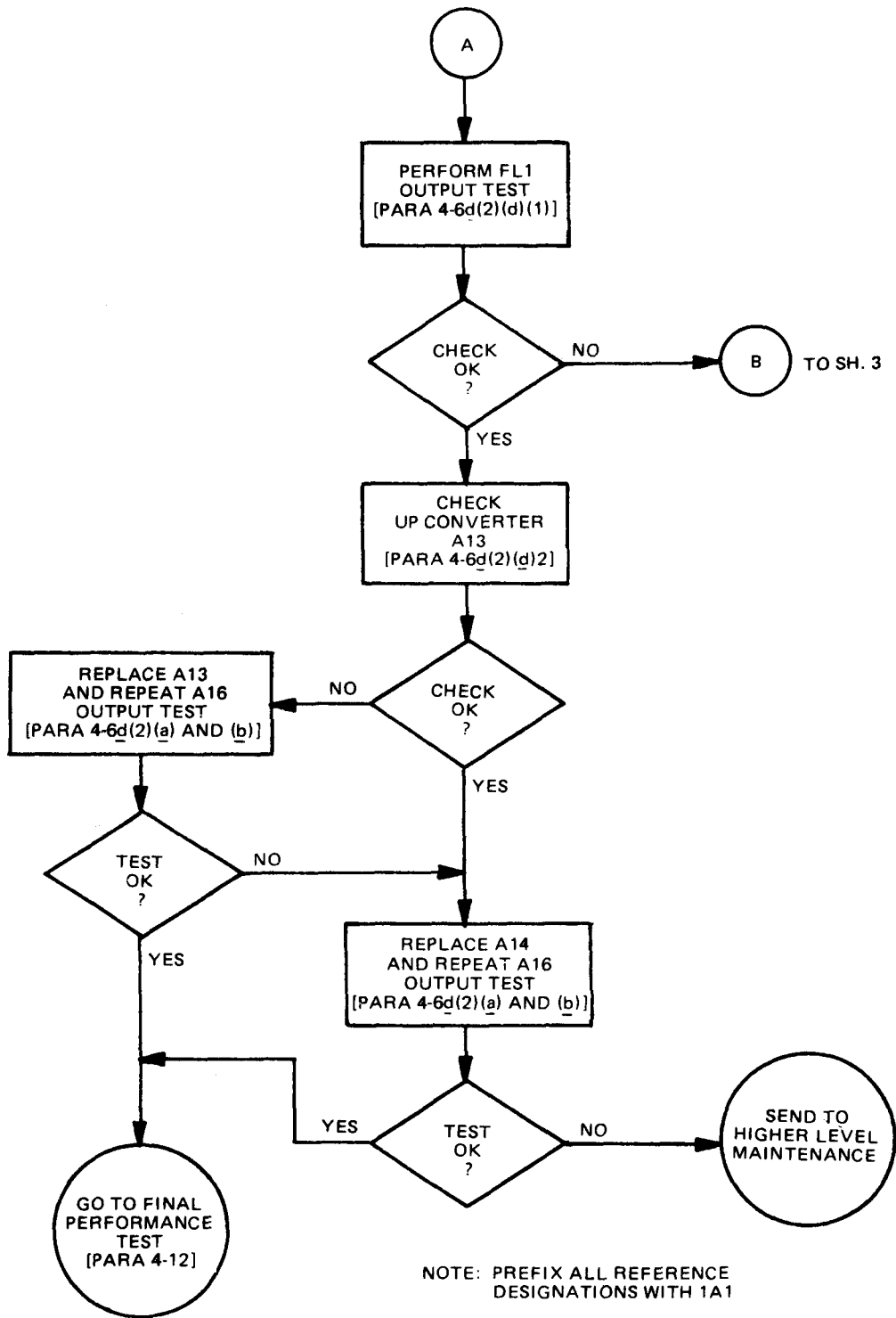
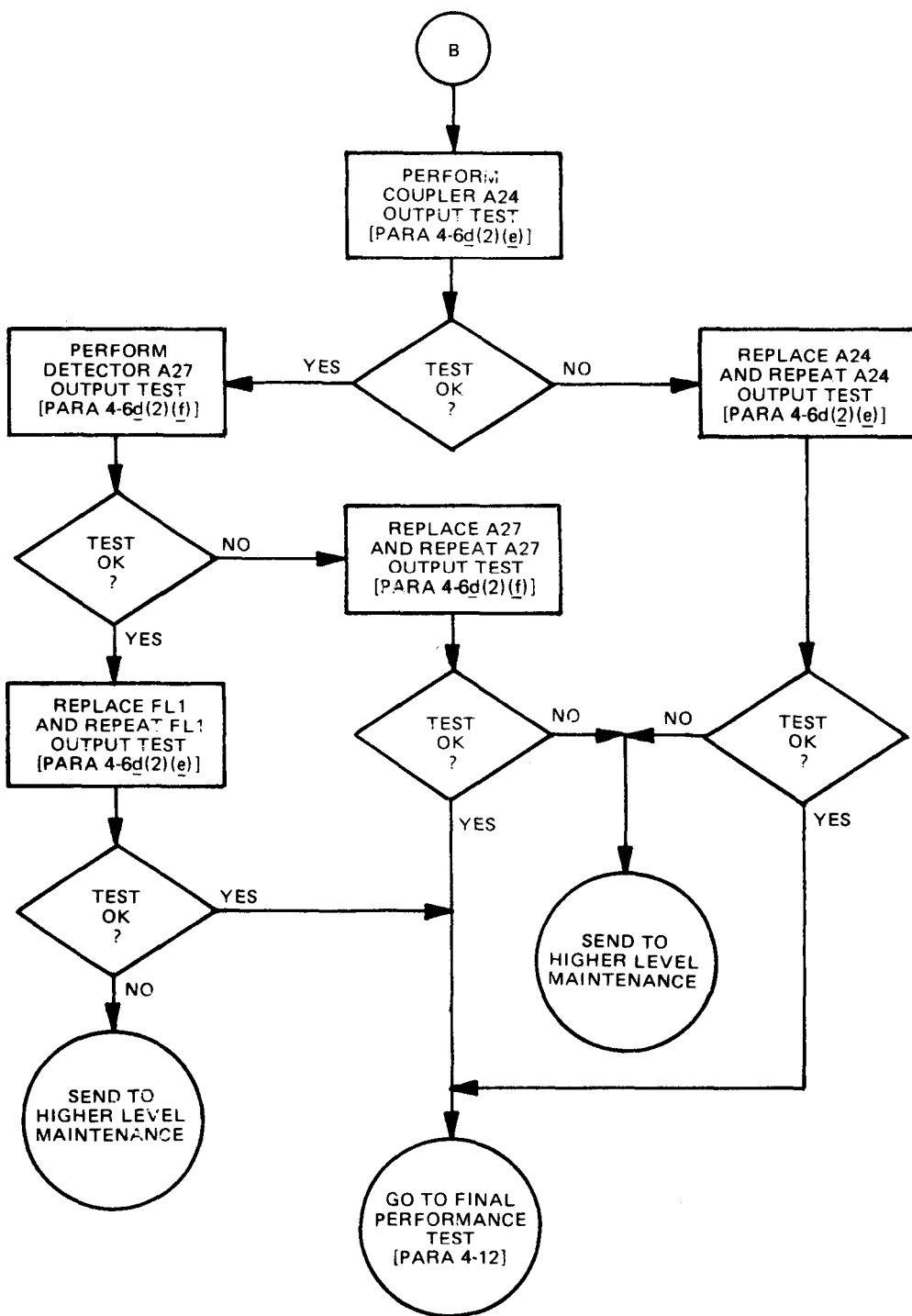

Figure 4-32. RF/IF signal path troubleshooting diagram (sheet 1 of 3).



EL5WS072 ©

Figure 4-32. RF/IF signal path troubleshooting diagram (sheet 2 of 3).



NOTE: PREFIX ALL REFERENCE DESIGNATIONS WITH 1A1

EL5WS072 ③

Figure 4-32. RF/IF signal path troubleshooting diagram (sheet 3 of 3).

(c) IF Selectivity 1A1A14 output test.

1. 1A1A14 check.

(a) Set the Signal Generator voltage level to 400 mV and set step attenuator to 6 dB.

(b) Using RF Voltmeter and unterminated probe, check output voltage at 1A1A14P2. Level should be more than 150 mV RMS.

(c) If output is not correct go to FL1 output test paragraph 4-6d(2)(d).

(d) If output is correct, check First IF 1A1A15.

2. First IF 1A1A15 check.

(a) Set step attenuator for 30 dB.

(b) Using RF Voltmeter and unterminated probe, check voltage at 1A1A15P5 for a level more than 100 mV RMS.

(c) If receive gain is correct, then replace and recheck 1A1A16. If output is correct, go to final performance test paragraph 4-12; if output is not correct, send RT to higher level maintenance.

(d) If gain is not correct, then replace and repeat 1A1A15 check. If incorrect, send RT to higher level maintenance, if correct, go to final performance test paragraph 4-12.

(d) 1A1FL1 output test.

1. Filter 1A1FL1 output check.

(a) Disconnect cable 1A1W7 from 1A1FL1J1.

(b) Adjust step attenuator to 6 dB. Check voltage level at 1A1FL1J1 using RF Voltmeter, 50 ohm load and Test Cable No. 1. The level should be more than 175 mV RMS.

(c) Disconnect voltmeter and reconnect 1A1W7.

(d) If output is not correct, go to 1A1A24 output test.

(e) If Output is correct, perform 1A1A13 check.

2. Upconverter 1A1A13 check.

(a) Set Signal Generator output level to 400 mV and set step attenuator for 6 dB.

(b) Using RF Voltmeter and unterminated probe, measure output level at 1A1A13P5. Level should be more than 175V RMS.

(c) If 1A1A13 output is not correct, replace 1A1A13.

(d) If 1A1A13 output is correct, replace 1A1A14 and recheck 1A1A14 output. If 1A1A14 output is not correct, send RT to higher level maintenance; if correct, go to final performance test paragraph 4-12.

(e) Coupler 1A1A24 output level test.

1. Set the step attenuator to 6 dB.

2. Monitor the output at red (A27E1) and black leads (fig. 4-31, sheet 3) with an oscilloscope for a level more than 400 mV peak to peak.

3. If output is not correct, replace A24 and repeat test. If test is not correct send RT to higher level maintenance. If output is correct go to final performance test paragraph 4-12.

4. If output is correct, perform 1A1A27 output test.

(f) Detector 1A1A27 output test.

1. Disconnect relay K1 lead from 1A1FL1J2 and connect relay lead to RF Voltmeter with 50 ohm load using Test Cable No. 2.

2. Set step attenuator to 6 dB.

3. RF Voltmeter should read more than 175 mV RMS.

4. Disconnect test equipment. Reconnect lead to 1A1FL1J2.

5. If output is not correct, replace 1A1A27 and repeat test. If output is still *incorect* send RT to higher level maintenance; if output is now correct go to final performance test paragraph 4-12.

6. If output is correct replace FL1 and repeat FL1 output test.

(3) IF signal path test (part 1).

(a) Initial test setup.

1. Connect test equipment as shown in figure 4-33.

2. Set RT controls as follows:

Control	Setting
POWER	RCV ONLY
MODE	AM
SQUELCH	OFF
FREQUENCY	02.1500 MHz

3. Set 1A1A2S1 switch to TEST position.

4. Refer to figure 4-34 for test point locations and figure 4-35 for troubleshooting diagram. See figure FO-11 for signal path diagram.

(b) IF Gain 1A1A3 output test.

1. Set signal generator output voltage to 4 mV.

2. Monitor 1A1A3P4 using distortion analyzer and adjust step attenuator for 250 to 300 mV. Step attenuator attenuation shall be greater than 70 dB.

3. If output is correct perform Audio test paragraph 4-6d(4).

4. If output is not correct perform 1A1A17 output test.

(c) Second IF 1A1A17 output test.

1. Remove Oscillator Distributor 1A1A10.

2. Set step attenuator to 50 dB and signal generator to 400 mV.

3. Using oscilloscope, measure voltage output at 1A1A17P5 for a voltage level greater than 150 mV peak to peak.

4. Reinstall Oscillator Distributor 1A1A10.

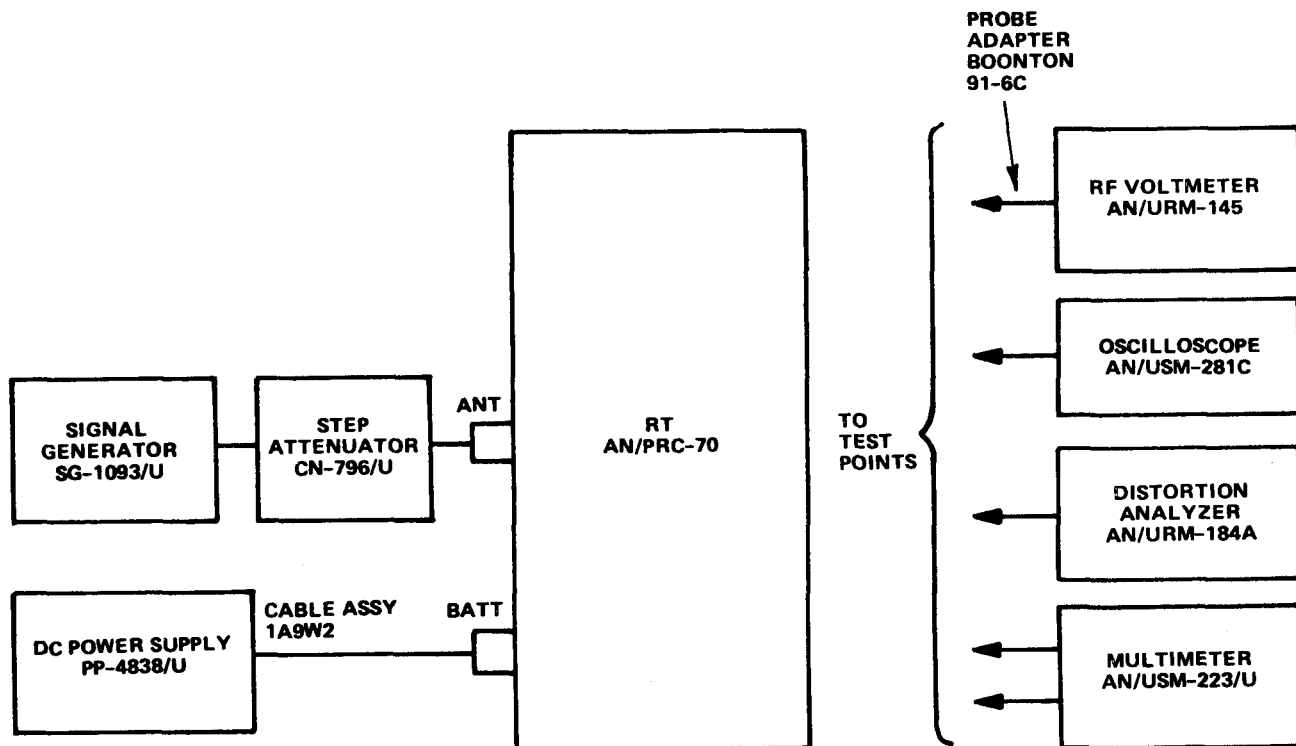

EL5WS073

Figure 4-33. IF signal path test setup.

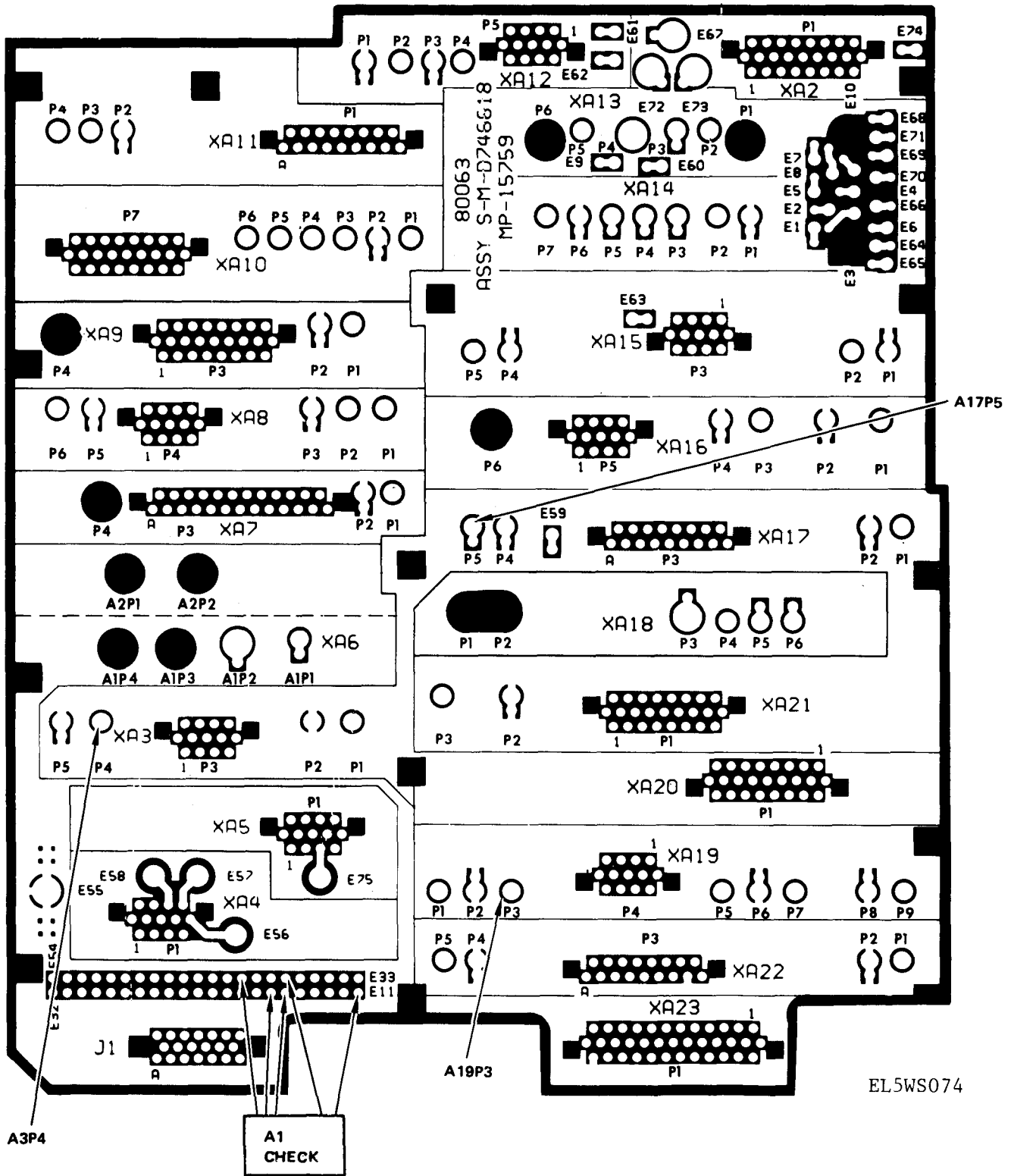

NOTE: PREFIX ALL REFERENCE DESIGNATIONS WITH 1A1A31.

Figure 4-34. IF signal path test point location.

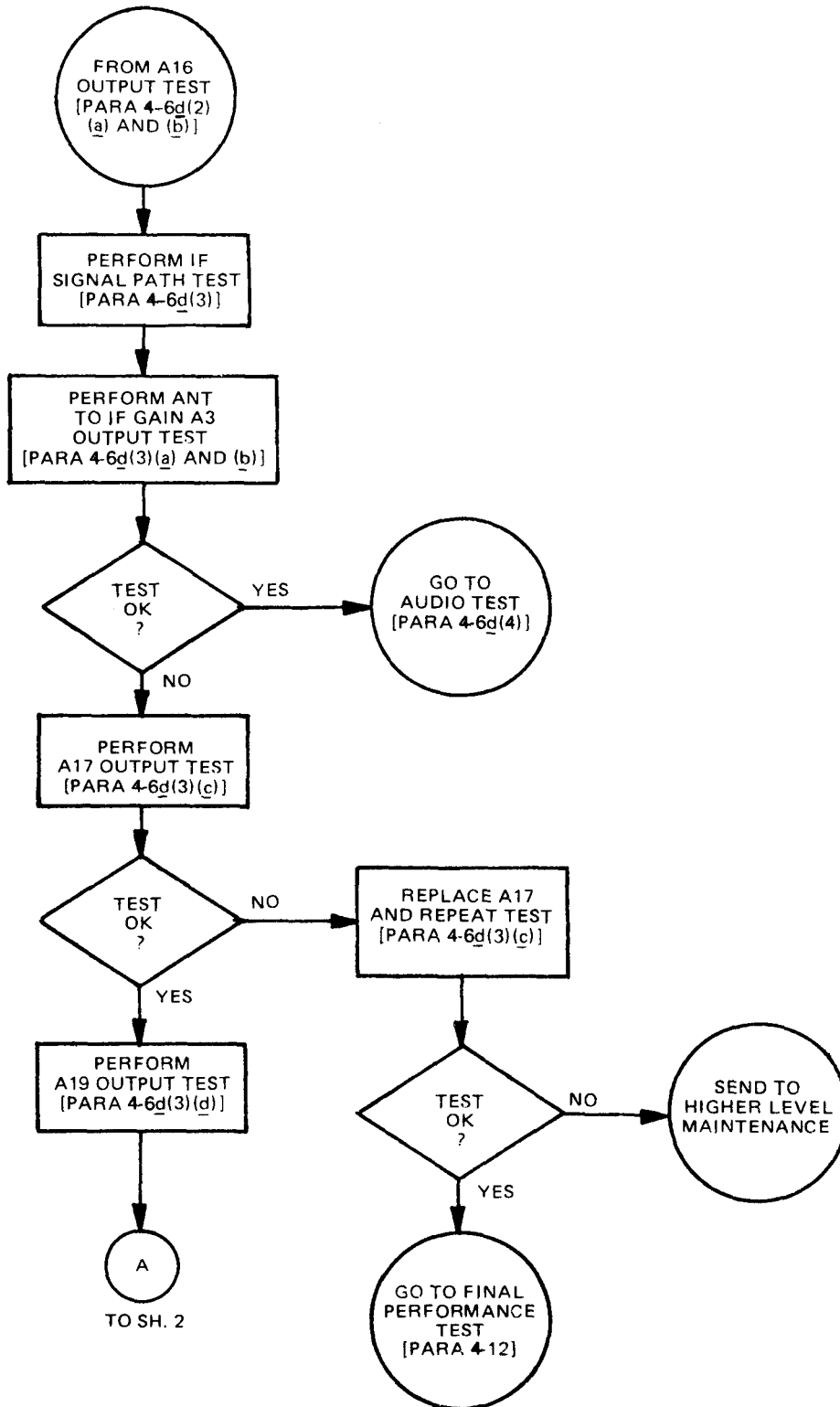

NOTE: PREFIX ALL REFERENCE DESIGNATION WITH 1A1

EL5WS075 ①

Figure 4-35. IF signal path troubleshooting diagram (sheet 1 of 2).

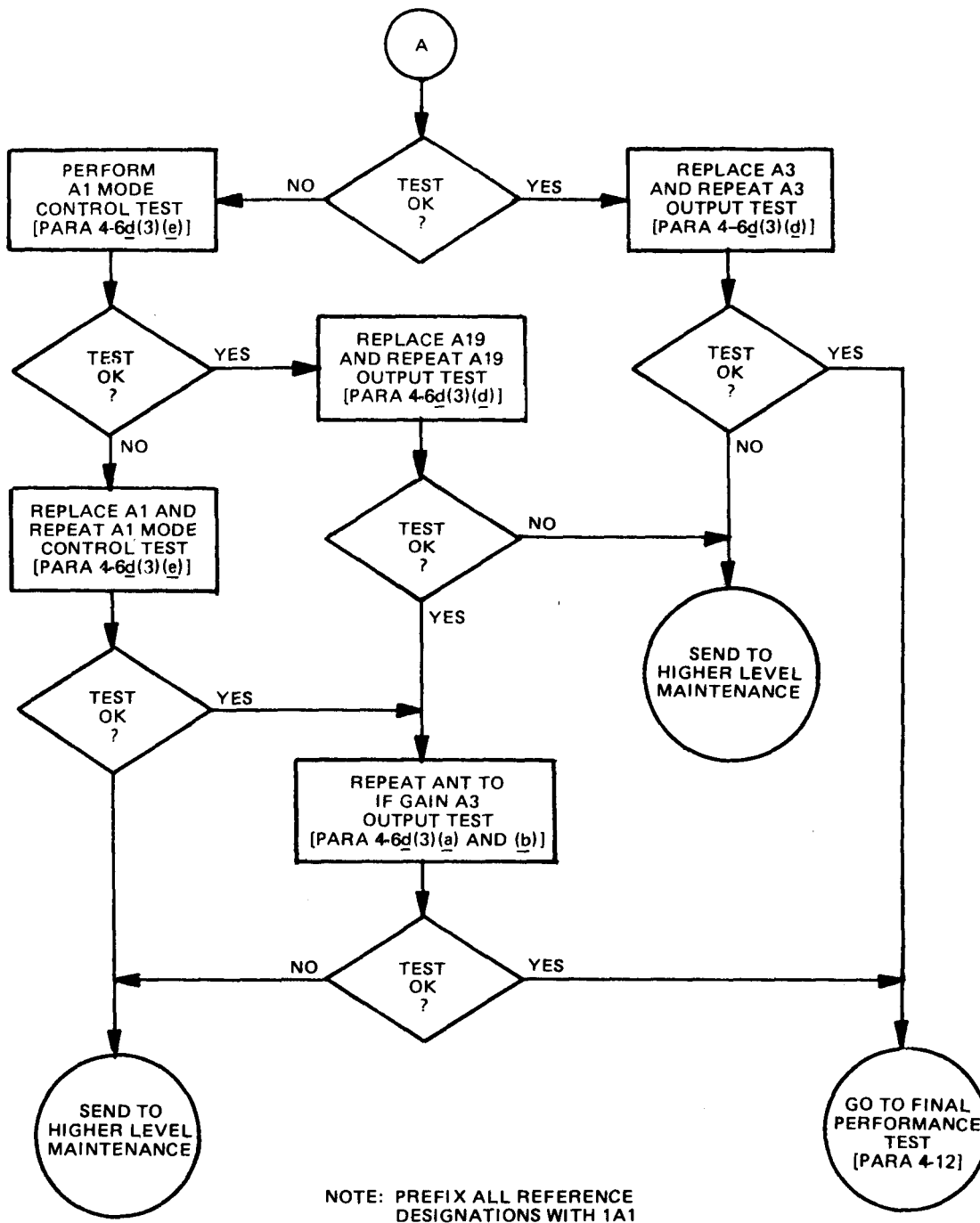

EL5WS075 ②

Figure 4-35. IF signal path troubleshooting diagram (sheet 2 of 2).

5. If output is not correct, replace 1A1A17 and repeat test. If output is now correct go to final performance test in paragraph 4-12. If output is still incorrect forward RT to higher level maintenance.

6. If output is correct, perform 1A1A19 test.

(d) IF Selectivity 1A1A19 output test.

1. Set signal generator level to 400 mV and step attenuator to 50 dB.

2. Using oscilloscope, measure voltage at 1A1A19P3 for a voltage level greater than 40 mV peak to peak.

3. If output is correct replace 1A1A3 and repeat 1A1A3 test.

4. If output is incorrect perform 1A1A1 test.

(e) Frequency Selector 1A1A1.

1. Check dc voltage with a multimeter at following connection points on Parent Board 1A1A31 MODE switch is rotated through all positions.

Connection Points	MODE - voltage (dc)				
	AM	FM	SSB	CW	FSK
1A1A31					
E11	+5	-5	-5	-5	-5
E41	-5	+5	-5	-5	-5
E17	-5	-5	+5	-5	-5
E38	-5	-5	-5	+5	-5
E16	-5	-5	-5	-5	+5

(4) Receive audio tests.

(a) Initial test setup.

1. Connect test equipment as shown in figure 4-36.

2. Set RT Volume control fully clockwise and Mode control to AM.

3. For following tests set Signal Generator to AM mode, 30 percent modulation at a 1 kHz rate.

4. Refer to figure 4-37 for test point locations and figure 4-38 for troubleshooting flow diagram. Refer to figure FO-12 for signal path diagram.

(b) A3 output level TEST in TEST/OPERATE mode.

1. Set the step attenuator to 32 dB. Monitor the output at A3-P4 with the oscilloscope.

2. Set the AGC TEST/OPERATE SWITCH on the A2 module to OPERATE. The A3-P4 output level will change from greater than 150 mV P-P to 50 ±20 mV P-P.

(c) Module A22 test. Using Distortion Analyzer, check audio level at 1A1A22TP1. Voltage level should be 30 ±10 mV RMS.

(d) A23 audio output level TEST.

1. Set module 1A1A2 TEST/OPERATE switch to TEST.

2. Using Distortion Analyzer, check audio voltage level at 1A1A31E39. Voltage level should be 1.0 V ±0.4 volts RMS.

3. A1 Test (volume control output). Using Distortion Analyzer, check audio voltage level at 1A1A31E40. Voltage level should be 1.0 ±0.4 volts RMS.

e. Receive AGC Test.

(1) Initial test setup.

(a) Setup test equipment as shown in figure 4-39.

(b) Set module 1A1A2 Test/Operate switch to operate position.

(c) Monitor the AGC voltage at A31-E63 with a DC voltmeter. Refer to figure 4-40 for test point locations.

(d) Refer to figure 4-41 for troubleshooting flow diagram.

(2) Module 1A1A22 check.

(a) Set the signal generator output level to 150 mV. The voltage at A31-E63 should be more than -1 volt.

(b) If the above is not correct, replace A22 module and repeat test.

(3) Module 1A1A17 check.

(a) Adjust the signal generator output level using dB scale while monitoring A31-E63 AGC voltage. Record the input level necessary to achieve AGC voltages of +4, +3, and +1 volts.

(b) If the signal generator level difference is less than 12 dB between 4 and 3 volts, replace A17 and repeat test.

(4) Module 1A1A15 check. If the level difference recorded in step (3)(a), is less than 18 dB between 3 and 1 volts, replace A15 and repeat test.

(5) Module 1A1A3 check.

(a) While monitoring the output at A3-P4, vary the input signal from 100 ±V to 150 mV.

(b) If the output signal level changes more than 3 dB, replace A3 and repeat test.

f. Narrow Band Audio Troubleshooting Test. The following troubleshooting procedures are performed if indicated by failure of test 6, 7, or 8 in figure 4-3.

(1) Initial narrow band audio test setup.

(a) Connect test equipment as shown in figure 4-42.

(b) Adjust DC Power Supply for 24 ±0.5 V dc with current limited to 10 amperes.

(c) Set RT controls as follows:

Control	Setting
POWER	RCV ONLY
MODE	Failed Mode
FREQUENCY	Failed Frequency

(d) Adjust RF Signal Generator frequency to the failed frequency and modulation. AM mode is

set for 30 percent at 1 kHz, FM is set at 8 kHz deviation. SSB is set to CW. Set level for 3500 μ V.

(e) Figure 4-43 shows test point locations and figure 4-44 shows the troubleshooting diagram.

(2) *IF Detector 1A1A22 test.*

(a) Use Distortion Analyzer to measure for a level of 20 to 50 mV at 1A1A22-TP1.

(b) Measure distortion of less than 7 percent for AM or SSB or FM of less than 10 percent.

(c) If test passes, replace 1A1A23 and repeat test.

1. If retest passes, go to final performance test paragraph 4-12.

2. If retest fails, send RT to higher level maintenance.

(d) If initial test fails, replace 1A1A22 and repeat test.

1. If retest passes, go to final performance test paragraph 4-12.

2. If retest fails, send RT to higher level maintenance.

g. *Squelch/Retransmit Tests.*

(1) *Initial test setup.*

(a) Connect test equipment as shown in figure 4-45.

(b) Set RT controls as follows:

<i>Control</i>	<i>Setting</i>
MODE	AM
FREQUENCY	02.1500 MHz
SQUELCH	OFF
POWER	RCV ONLY

(c) Set Signal Generator to 2.150 MHz in AM mode modulated at a 500 Hz rate with output voltage at 3500 μ V.

(d) Adjust RT VOLUME control for a 1.5 \pm 0.2 VRMS indication on Distortion Analyzer.

(e) Set RT SQUELCH control to ON, audio voltage level should remain at 1.5 RMS \pm 0.2.

(f) Disconnect Signal Generator, audio output voltage should drop more than 20 dB. Reconnect Signal Generator.

(g) Refer to figure 4-46 for test point locations and figure 4-47 for troubleshooting diagram.

(2) *Squelch test.*

(a) *Frequency Selector 1A1A1 check.*

1. Check dc voltage at 1A1A31E34 using multimeter. Voltage indication should be +5 V dc \pm 0.5 V with SQUELCH control ON and zero volts with SQUELCH control OFF.

2. Set SQUELCH control to ON.

(b) *Modulator/Squelch 1A1A21 check.*

1. Using multimeter, check voltage at 1A1A21P1 pin 16 for an indication of -3 \pm 0.5 V dc.

2. Disconnect signal generator and check 1A1A21P1 pin 16 for +3 \pm 0.5 V dc.

3. Reconnect signal generator.

(3). *Retransmit audio test.*

(a) Set RT SQUELCH control to RXMT.

(b) Connect Distortion Analyzer to RXMT connector 1A1J3 pin B with a 1000 ohm load to check audio voltage level more than 0.15 VRMS.

(c) Connect Isolation Box to RT connector 1A1J3.

(d) Set Isolation Box 1K/500 ohm switch to 1K ohm.

(e) Using distortion analyzer, measure audio voltage level. If voltage is less than 0.15V RMS the test fails.

(f) Set RT VOLUME control to minimum (full ccw).

(g) Audio voltage level should remain at level measured in step (e) above.

(4) *Frequency Selector 1A1A1 check.* Use multimeter to check +5 \pm 0.3 V dc at 1A1A31E33.

(5) *Retransmit key test.*

(a) Connect multimeter negative probe to isolation box J6 (pin E to ground). Set multimeter to R x 1 scale to check resistance of less than 50 ohms.

(b) Disconnect Signal Generator.

(c) Set multimeter to R x 100 scale to check resistance more than 10,000 ohms.

(6) *DC Control 1A1A30 check.* Repeat retransmit key test above, step (5), except connect positive probe of multimeter to 1A1A31E4 and negative probe to ground.

h. *Receive Wideband Audio Troubleshooting Test.* The following troubleshooting procedures are performed when indicated by receive evaluation test No. 11 failure in figure 4-3. See figure 4-48 troubleshooting diagram.

(1) *IF Detector 1A1A22 test.*

(a) If receive evaluation test No. 11 fails, replace 1A1A11 and repeat evaluation test No. 11.

1. If test passes, go to final performance test paragraph 4-12.

2. If test fails, perform 1A1A23 test.

(2) *Audio 1A1A23 test.*

(a) If 1A1A22 test failed, replace 1A1A23 and repeat evaluation test No. 11.

(b) If 1A1A22 test passes, go to final performance test paragraph 4-12.

(c) If 1A1A22 test failed, send RT to higher level maintenance.

i. *Receive FSK/CW Troubleshooting Test.* The following tests are performed if FSK or CW evaluation test No. 12 or 13 of table 4-2 failed. See figure 4-49 for troubleshooting diagram. Perform IF Selectivity 1A1A19 test first.

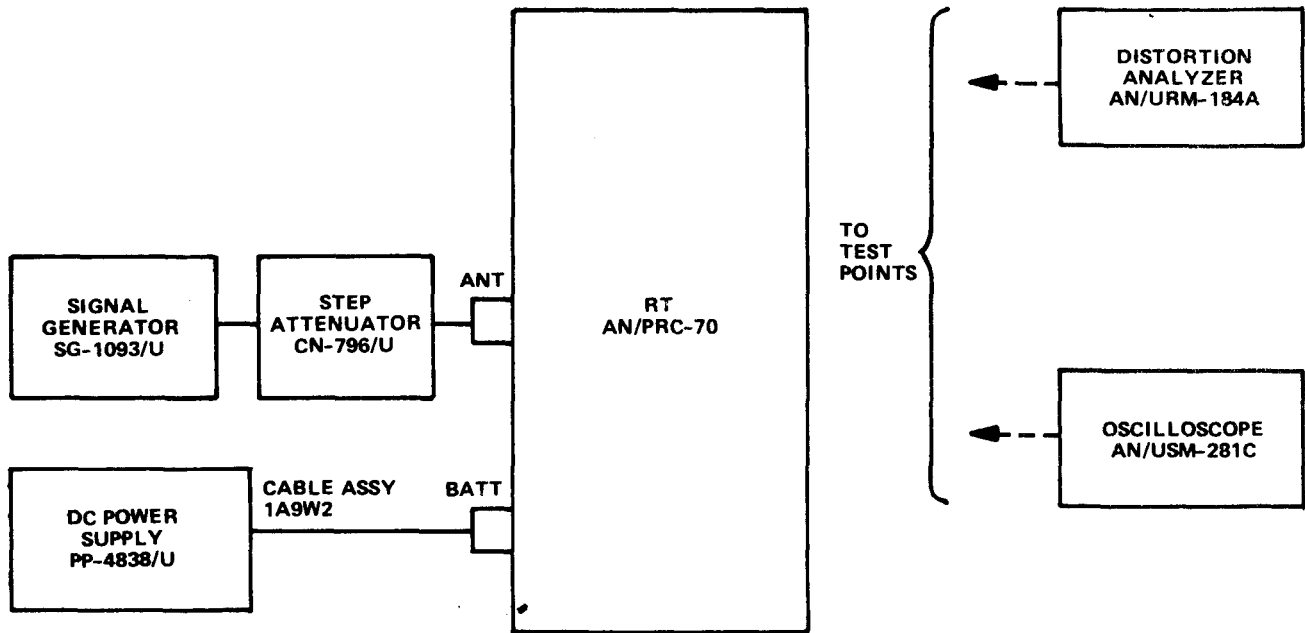

EL5WS076

Figure 4-36. Receive audio test setup.

(1) *IF Selectivity 1A1A19 test.*

(a) If FSK or CW test No. 12 or 13 of table 4-3 failed, replace 1A1A19 and repeat the failed test.

(b) If test passed, go to final performance test paragraph, 4-12.

(c) If test failed, perform 1A22 test.

(2) *IF Detection 1A1A22.*

(a) If 1A19 test failed, replace 1A1A22 and repeat failed test.

(b) If test passes, go to final performance test paragraph 4-12.

(c) If test fails, send RT to higher level maintenance.

j. Receive SINAD Troubleshooting Tests. The following troubleshooting tests are performed if one or more receive evaluation tests No. 14 through 23 of table 4-2 failed.

(1) *Initial Receive SINAD test setup.*

(a) Setup test equipment as shown in figure 4-50.

(b) Set RT controls as described in failed evaluation test paragraph 4-5a(9) and (10).

(c) Set Signal Generator as shown in table 4-3.

(d) Figure 4-51 shows the troubleshooting diagram.

(2) *Initial Receive SINAD test.*

(a) Raise Signal Generator output level 60 dB.

(b) Check sensitivity as described in paragraph 4-5a(2) for the failed frequency and mode.

(c) If test passes, replace Coupler 1A1A24 and repeat the failed receive evaluation test.

1. If evaluation test passes, go to final performance test paragraph 4-12.

2. If evaluation test fails, send RT to higher level maintenance.

(d) If initial test failed, perform Pump VFO test paragraph (3) below.

(3) *Pump VFO closed loop test.*

(a) Perform Pump VFO test in paragraph 4-6b(1) at the failed frequency plus 111.455 MHz and mode.

(b) If Pump VFO test passed, send RT to higher level maintenance.

(c) If test failed, perform Translator 1A1A6 test paragraph (4) below.

(4) *Translator 1A1A6.*

(a) Perform Translator test in paragraph 4-6b(2) at the failed frequency and mode. Set signal generator to failed RT frequency plus 6.7 MHz \pm 5 kHz.

(b) If test passed, perform upper loop test paragraph (5) below.

(c) If test failed, perform lower loop test paragraph (6) below.

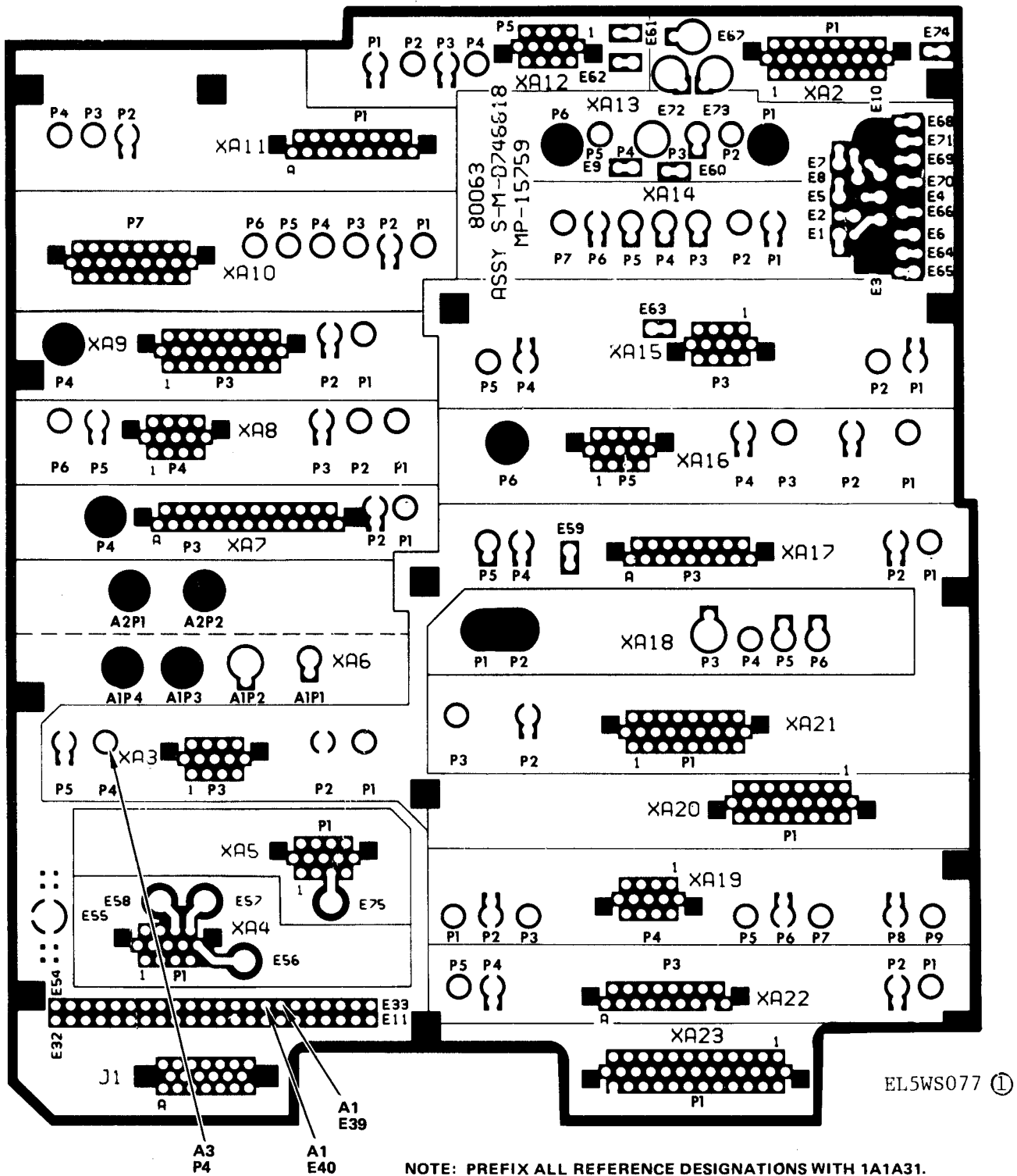

Figure 4-37. Receive audio point locations (sheet 1 of 2).

(5) Upper loop divider test.

(a) Perform upper loop divider test in paragraph 4-6b(5). Set the RT unit and signal generator to the frequency listed in table 4-5 that is closest to the failed frequency. See figure 4-23 to find the defective module.

(b) If the defective module has been identified and replaced, go to final performance test paragraph 4-12.

(c) If the defective module is not identified, send RT to higher level maintenance.

(6) Lower loop test.

(a) Perform lower loop test paragraph 4-6b(4) at the failed frequency.

(b) If test passes, replace Translator 1A1A6 and repeat failed Pump VFO test paragraph 4-6b(1).

1. If Pump VFO test passes, go to final performance test paragraph 4-12.

2. If Pump VFO test fails, send RT to higher level maintenance.

(c) If lower loop test fails, alternately replace Lower Loop 1A1A9 and Frequency Selector 1A1A1 and repeat lower loop test.

1. If defective module was replaced and test passed, go to final performance test paragraph 4-12.

2. If lower loop test failed, send RT to higher level maintenance.

4-7. Transmit Functional Troubleshooting Tests

The transit troubleshooting tests are listed in table 4-6. The applicable test paragraph is given for each test. Perform the tests in the order given or directed in the associated troubleshooting diagrams.

CAUTION

The minicoax cable connections on the bottom of the RT unit are held in their jacks with crimped coax retainers. To disconnect the coax cable when testing, use a pair of needle nose pliers. Bend up the retaining "ears" on the spring clips just enough to permit the cable connection to be parted.

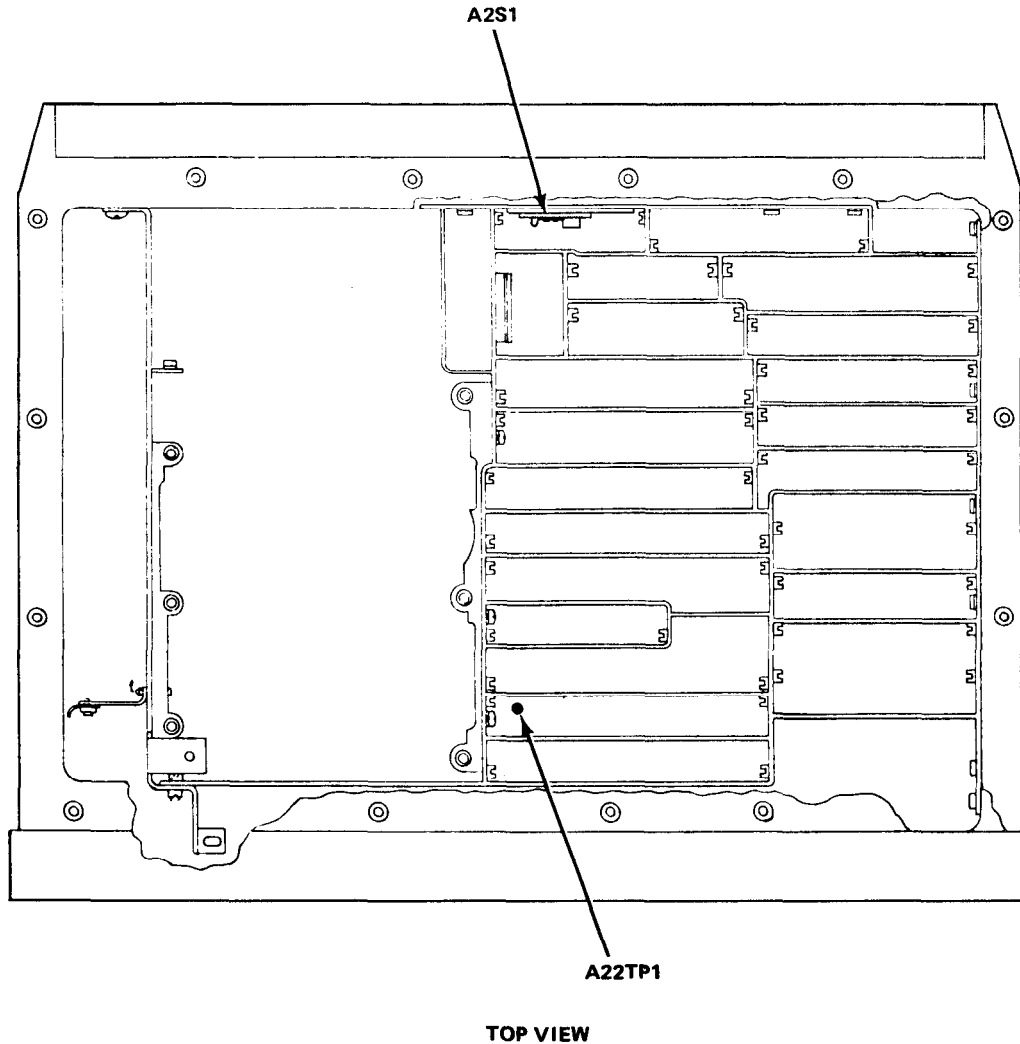

EL5WS077 ②

Figure 4-37. Receive audio test point locations (sheet 2 of 2).

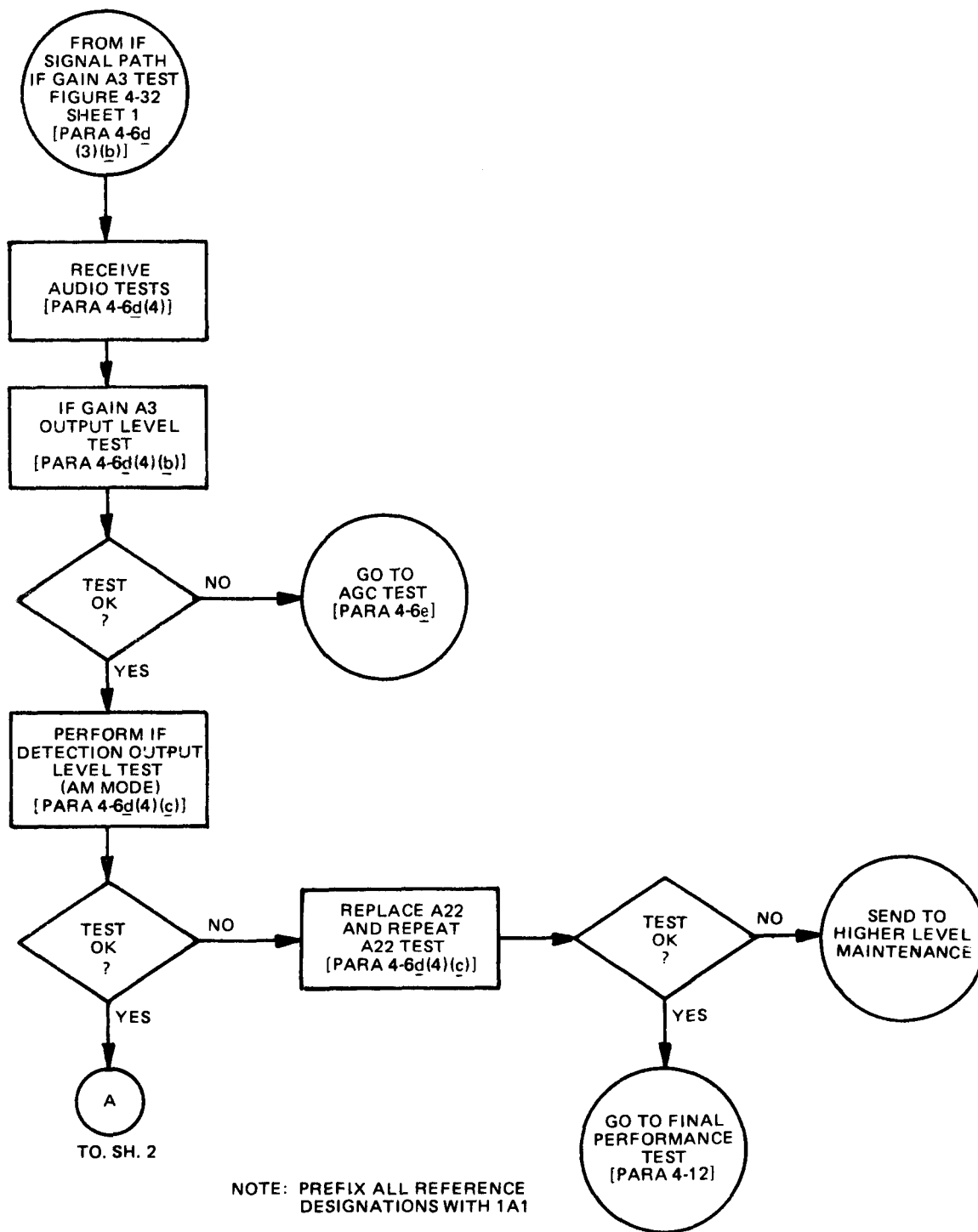

EL5WS078 ①

Figure 4-38. Receive audio troubleshooting diagram (sheet 1 of 2).

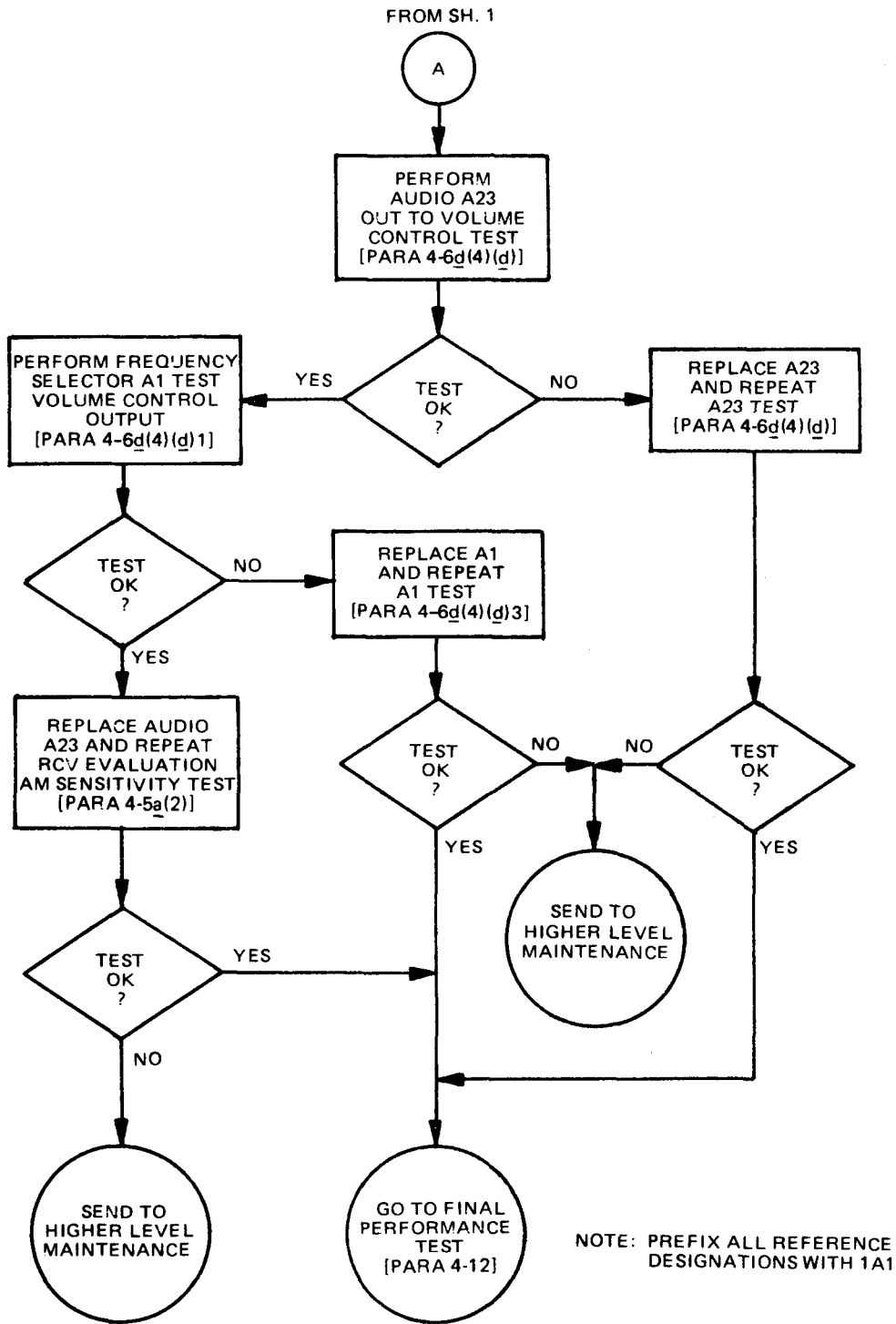

EL5WS078 (2)

Figure 4-38. Receive audio troubleshooting diagram (sheet 2 of 2).

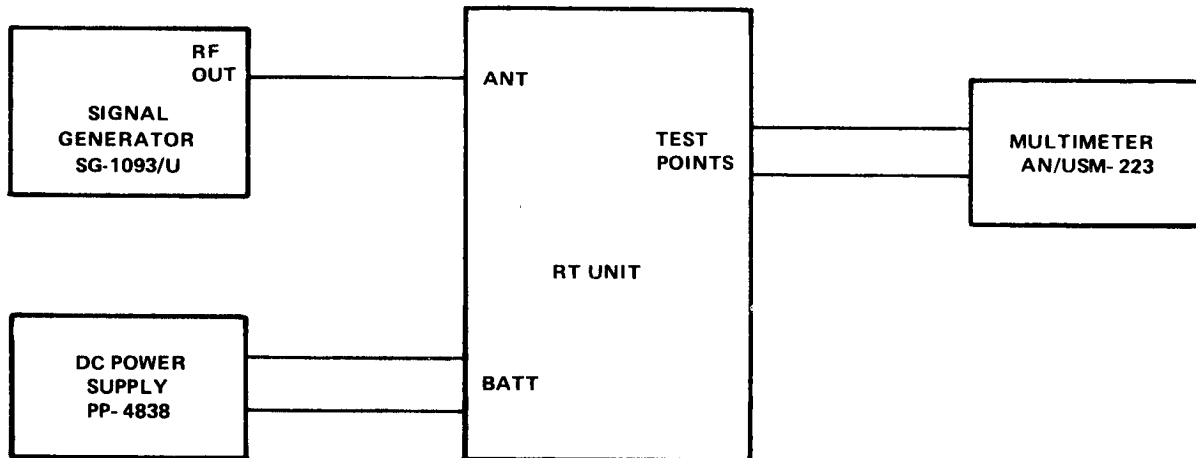

EL5WS079

Figure 4-39. AGC test setup.

a. Transmit Subgroup Isolation Tests (figure 4-52).

Table 4-6. Transmit Troubleshooting Tests

Para 4-7	Subject
a	Transmit Subgroup Isolation Tests
b	Transmit RF Signal Path Test
c	Transmit IF Signal Path Troubleshooting Tests
d	Transmit Audio Signal Path
e	No-Tune Test
f	Sidetone Tests
g	NB FM Transmit Audio Tests
h	Transmit CW/FSK Troubleshooting Test
i	Transmit Power Output Tests

(1) Transmit subgroup isolation test setup.

(a) Equipment setup.

1. Setup equipment as shown in figure 4-53.

NOTE

Extender card is not connected at this time.

(2) RT and equipment control settings.

(a) RT control settings.

1. POWER - LO PWR
2. MODE - SSB
3. FREQUENCY - 2.1500 MHZ
4. SQUELCH - OFF

(b) Equipment control settings.

1. Audio Oscillator No. 1 to 1500 Hz and an output level of 2.0 mV ac at J3 of the Isolation Box (Audio Oscillator No. 2 disconnected).

2. Audio Oscillator No. 2 to 2800 Hz and an output level of 2.0 mV ac at J3 of the Isolation Box (Audio Oscillator No. 1 disconnected).

3. Reconnect Audio Oscillator No. 1.

(3) Subgroup tests.

(a) Subgroup A23 to A12 test.

1. Key the RT.

2. Measure the RF output at 1A1W9-P1 using test cable No. 2 (figure 4-54) on the Oscilloscope. Reading should be between 3.6 and 6.2 V p-p.

3. Measure the ratio of width of the wave at the 75 percent amplitude point to the base width. This ratio must be less than 0.6 (see figure 4-55).

4. Unkey the RT.

(b) Subgroup A17 to A12 gain test.

1. Remove A17 and install A17 extender card in its place. Install A17 on the Extender Card (see figure 4-56).

2. Unplug the A19 module.

3. Connect the RF Generator and the Step Attenuator as shown in figure 4-53.

4. Set the RF Generator to 11.455 MHz \pm 10 Hz, CW mode, with an output level of 1.0 Vrms.

5. Set the Step Attenuator to 44 dB.

6. Short pin K (Tx AGC) on the 1A1A17 Extender Card to ground (see figure 4-56).

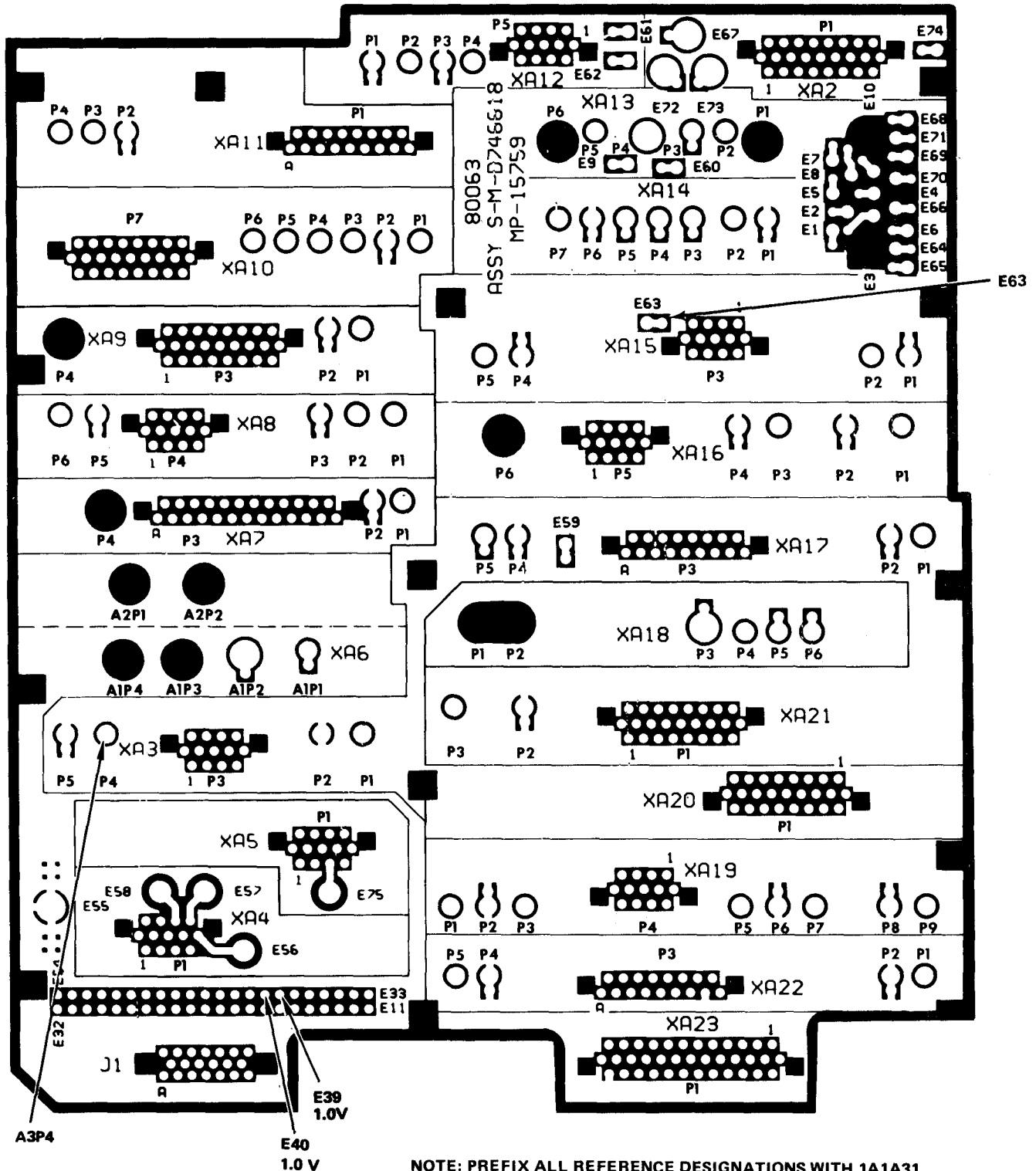
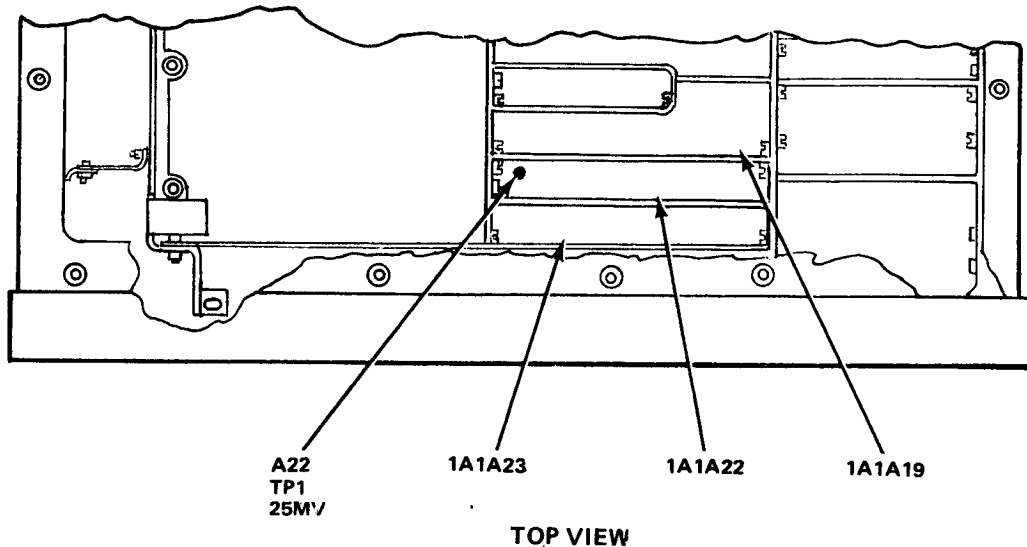

Figure 4-40. AGC test point locations (sheet 1 of 2).



EL5WS080 (2)

Figure 4-40. AGC test point locations (sheet 2 of 2).

7. Key the RT and measure the output at 1A1AW9-P1. Reading should be greater than 2.8 V p-p.

8. Unkey the RT.

(c) Subgroup A17 to A12 compression test.

1. Set the Step Attenuator to 40 dB.

2. Key the RT.

3. Measure the output at 1A1W9-P1.

Reading should be greater than 8.5 V p-p.

4. Unkey the RT.

5. Remove the extender card. Reinstall the A19 and A17 modules.

b. Transmit RF signal path test.

(1) RF path test setup.

(a) Set up equipment as shown in figure 4-57. See figure 4-58 for test point location.

(b) Connect oscilloscope channel 1 (CH1) to the PA side of CABLE ASSY 1A1W8 using test cable No. 2. See figures 4-57 and 4-58, sheet 2.

(2) RT and equipment control settings.

(a) RT control settings.

1. POWER - RCV ONLY

2. MODE - AM

3. FREQUENCY - (frequencies are noted in each test paragraph).

(b) Equipment control settings.

1. Adjust power supply to +24 ±0.5 V dc output.

2. Set Step Attenuator to 10 dB.

3. Set Signal Generator to 2.1500 MHz ±10 Hz at a level of 1.0 Vrms for all tests.

4. See figure 4-59 for troubleshooting diagram.

(3) RF signal path continuity troubleshooting tests.

(a) Coupler A24 continuity test.

1. Key the RT in RCV ONLY mode.

2. Using Oscilloscope channel 2 (CH 2), measure voltage level at Detector input, A27E1. Reading should be greater than 0.7V p-p. See figure 4-58, sheet 1.

3. Change the RT to the following frequencies (after each frequency change, level displayed on Oscilloscope channel 2 (CH 2) should drop and then settle down to a level greater than 0.7V p-p):

3.1500	10.1500	34.1500
4.1500	14.1500	44.1500
6.1500	24.1500	64.1500

4. Unkey the RT.

5. Return RT frequency setting to 2.1500 MHz.

(b) Harmonic Filter A28 input test.

1. Key the RT in RCV ONLY mode.

2. Using Oscilloscope channel (CH 1), measure the output voltage level. Reading should be greater than 0.7V p-p. See figure 4-57.

3. Change the RT to the following frequencies (after each frequency change, level displayed on Oscilloscope channel 1 (CH 1) should drop and then settle down to a level greater than 0.7V p-p):

2.1500	10.1500	34.1500
4.1500	14.1500	44.1500
6.1500	24.1500	64.1500

4. Unkey the RT.

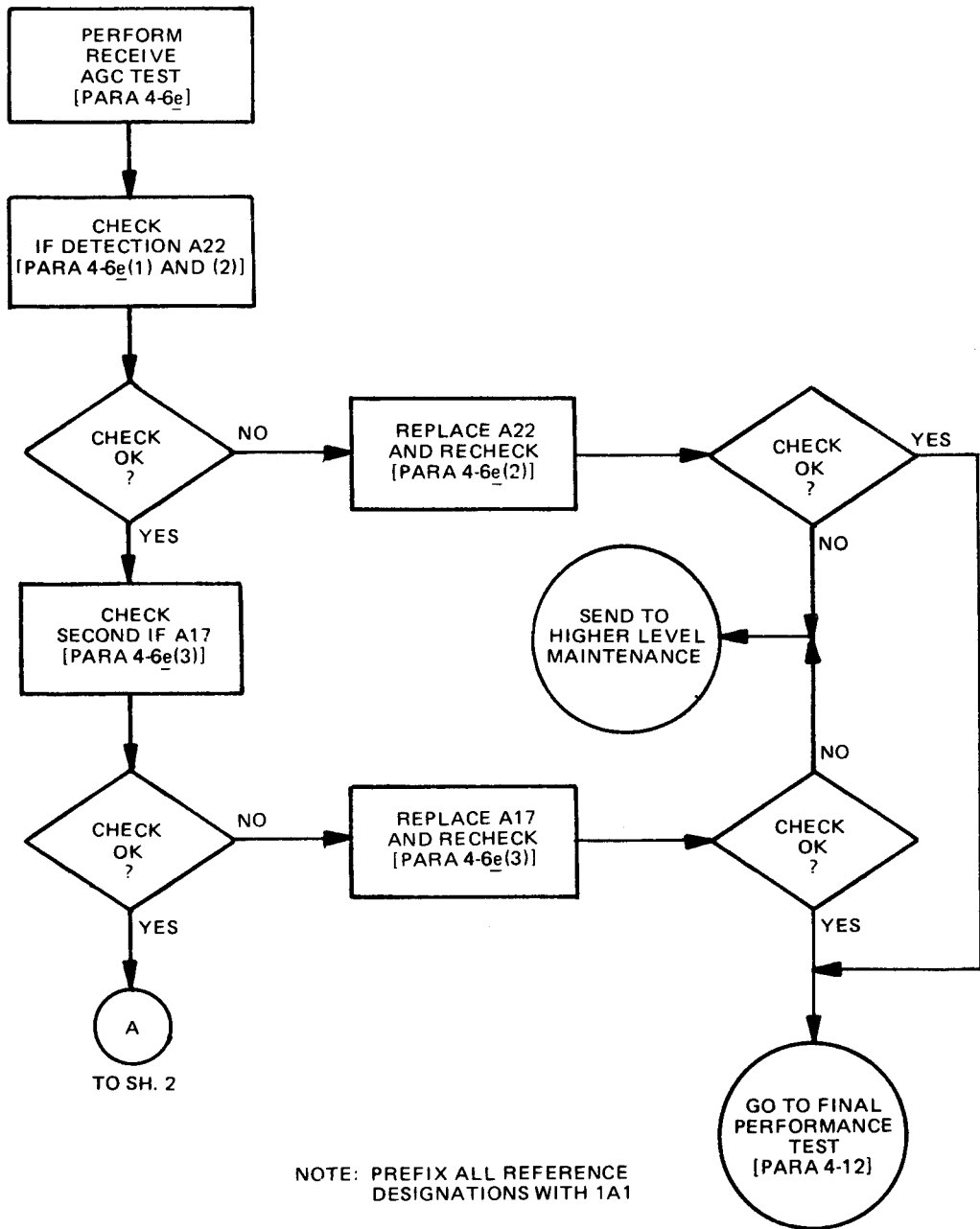

EL5WS081 ①

Figure 4-41. AGC troubleshooting diagram (sheet 1 of 2).

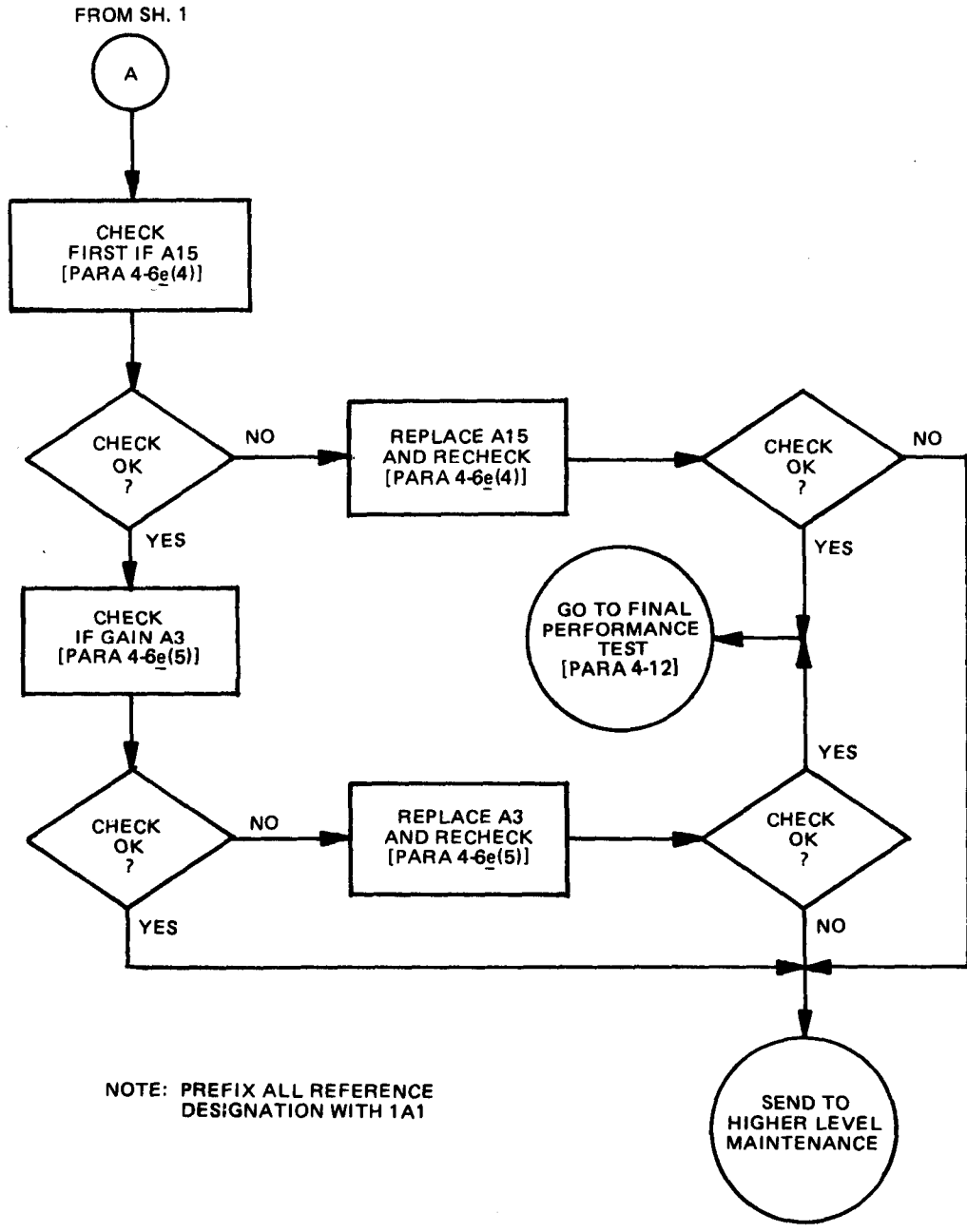

EL5WS081 ②

Figure 4-41. AGC troubleshooting diagram (sheet 2 of 2).

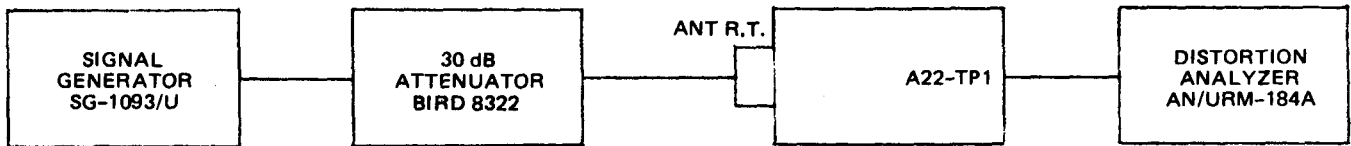

EL5WS082

Figure 4-42. Narrow band audio test setup.

5. Return the RT frequency setting to 2.1500 MHz.

6. Replace cable assembly 1A1AW8 removed in step 2 above.

(c) Harmonic Filter A28 output test.

1. Remove mating side of cable, identified as "FROM A28", from cable JACK (fig. 4-58, sheet 1).

2. Connect Oscilloscope channel 1 (CH 1), using test cable No. 1, to the JACK made available in step 1 above.

3. Key the RT in the RCV ONLY mode.

4. Oscilloscope indication should be greater than 0.7 V p-p.

5. Unkey the RT.

(d) Detector A27 input test.

1. Move test cable No. 1, connected to Oscilloscope channel 1, to A27J1 (keep the 50 ohm termination on CH 1).

2. Key the RT in RCV ONLY mode.

3. Oscilloscope indication should be greater than 0.7 V p-p.

4. Unkey the RT.

(4) *RF dynamic test equipment setup.* Setup test equipment as shown in figure 4-60. See figure 4-60.1 for test point locations and figure 4-61 for troubleshooting diagram.

(5) *RT and equipment control settings.*

(a) Set RT controls to:

POWER - RCV ONLY

MODE - SSB

FREQUENCY - 2.1500 MHZ

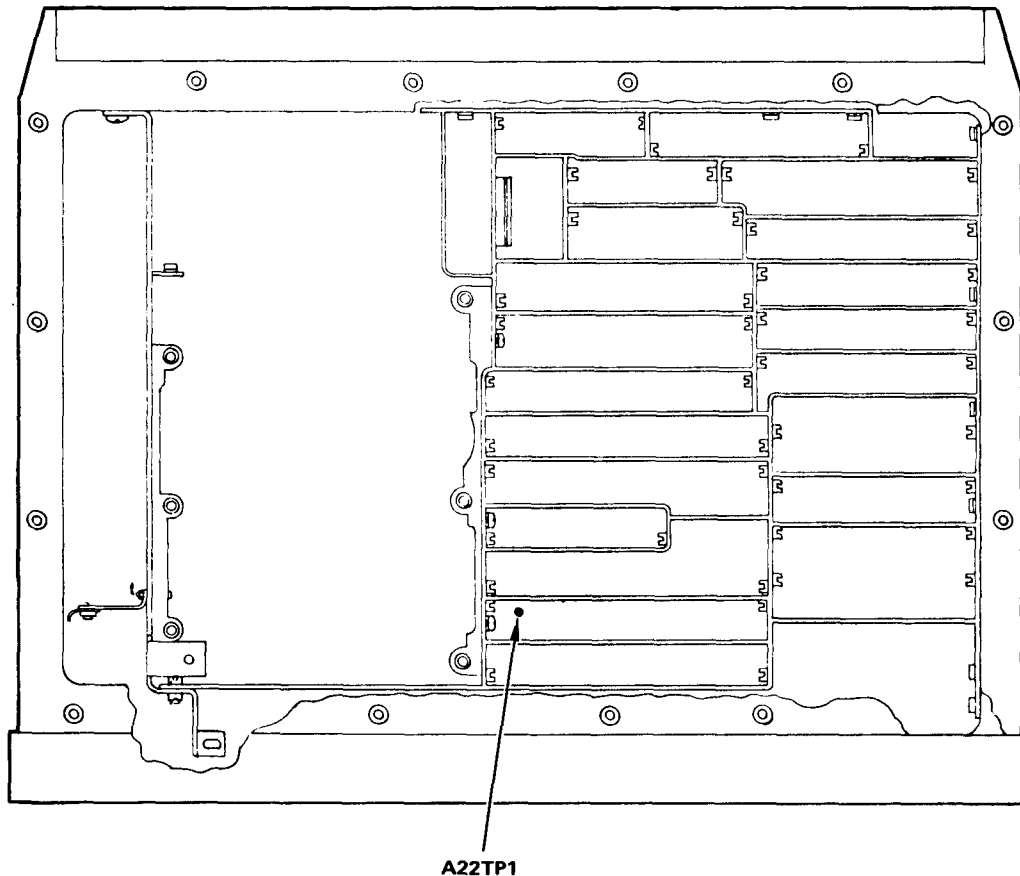

A22TP1

TOP VIEW

NOTE: ONLY TEST POINTS (TP) USED IN ISOLATION TEST ARE SHOWN

EL5WS083

Figure 4-43. Narrow band audio test point locations.

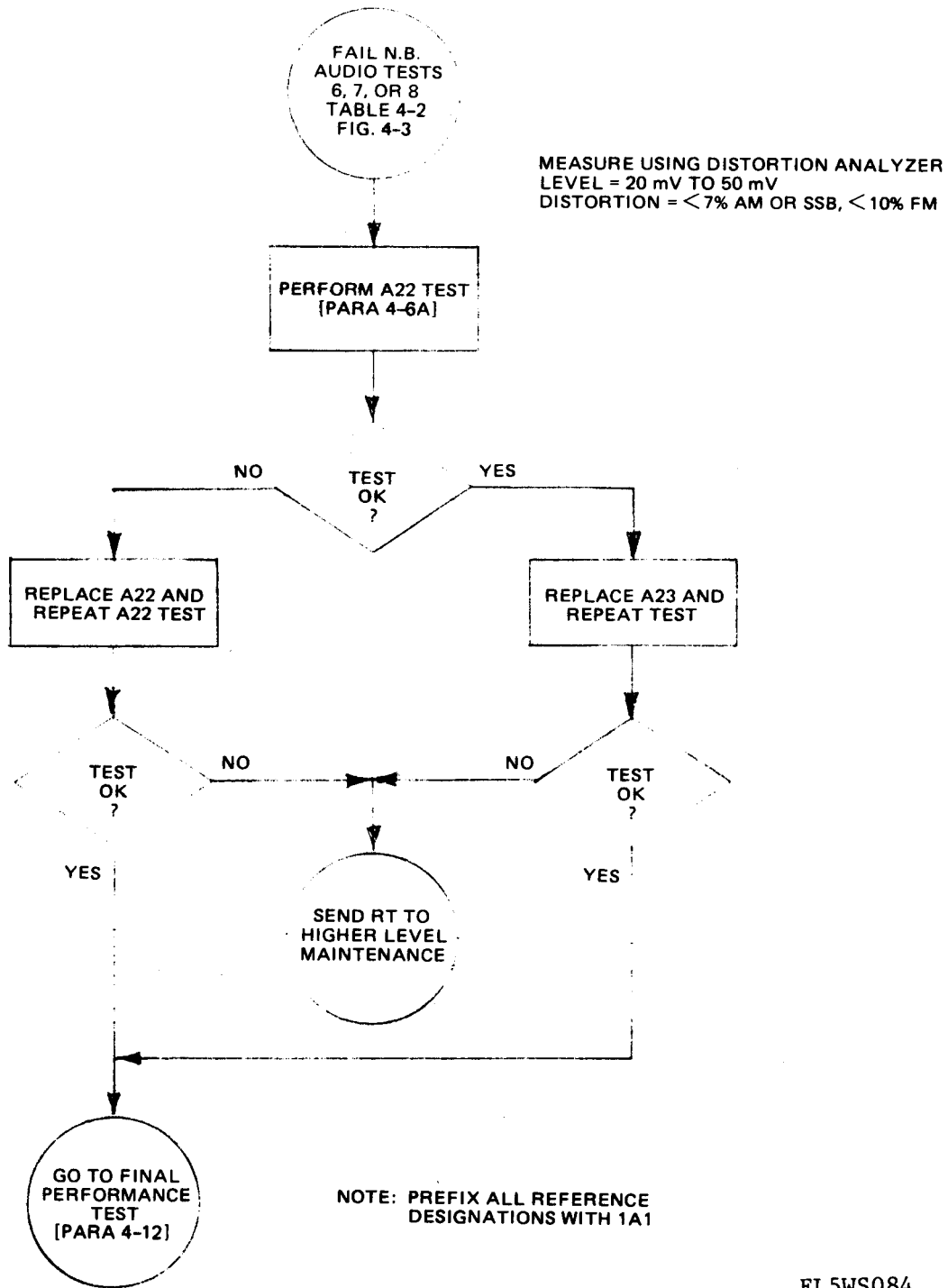
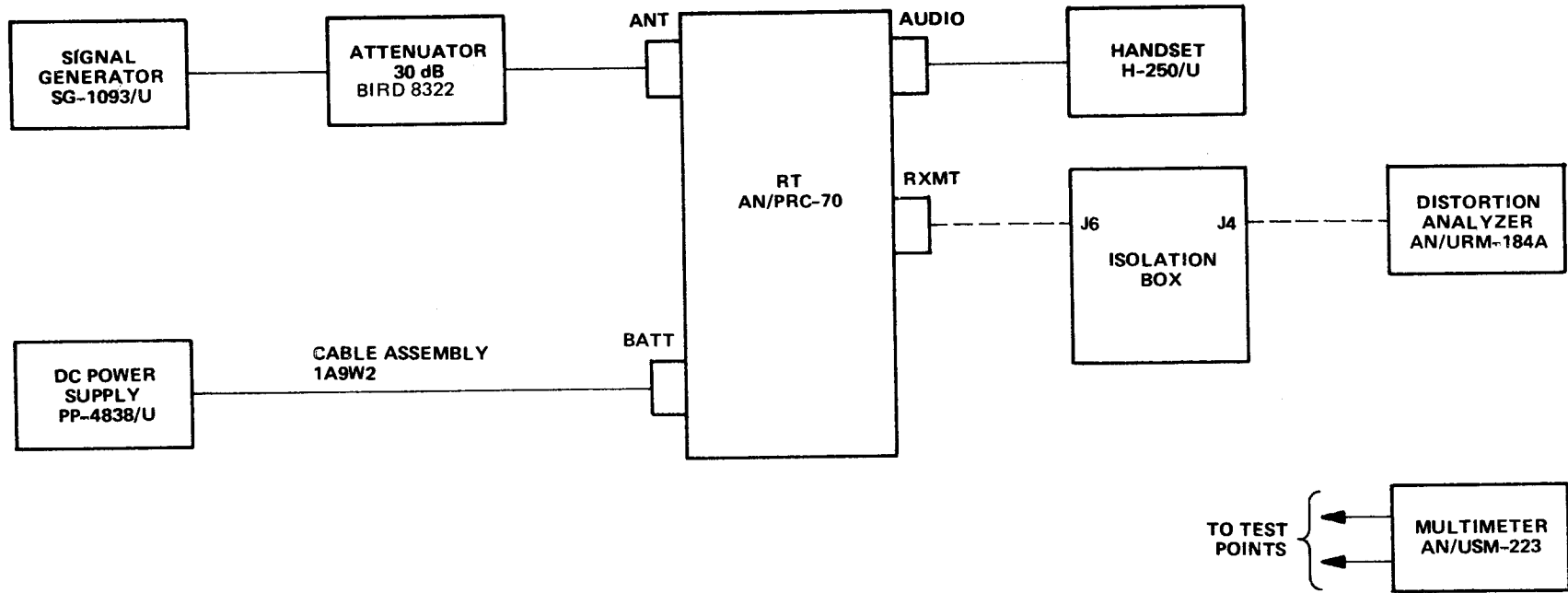

Figure 4-44. Narrow band audio troubleshooting diagram.

EL5WS084



EL5WS085

Figure 4-45. Squelch/retransmit test setup.

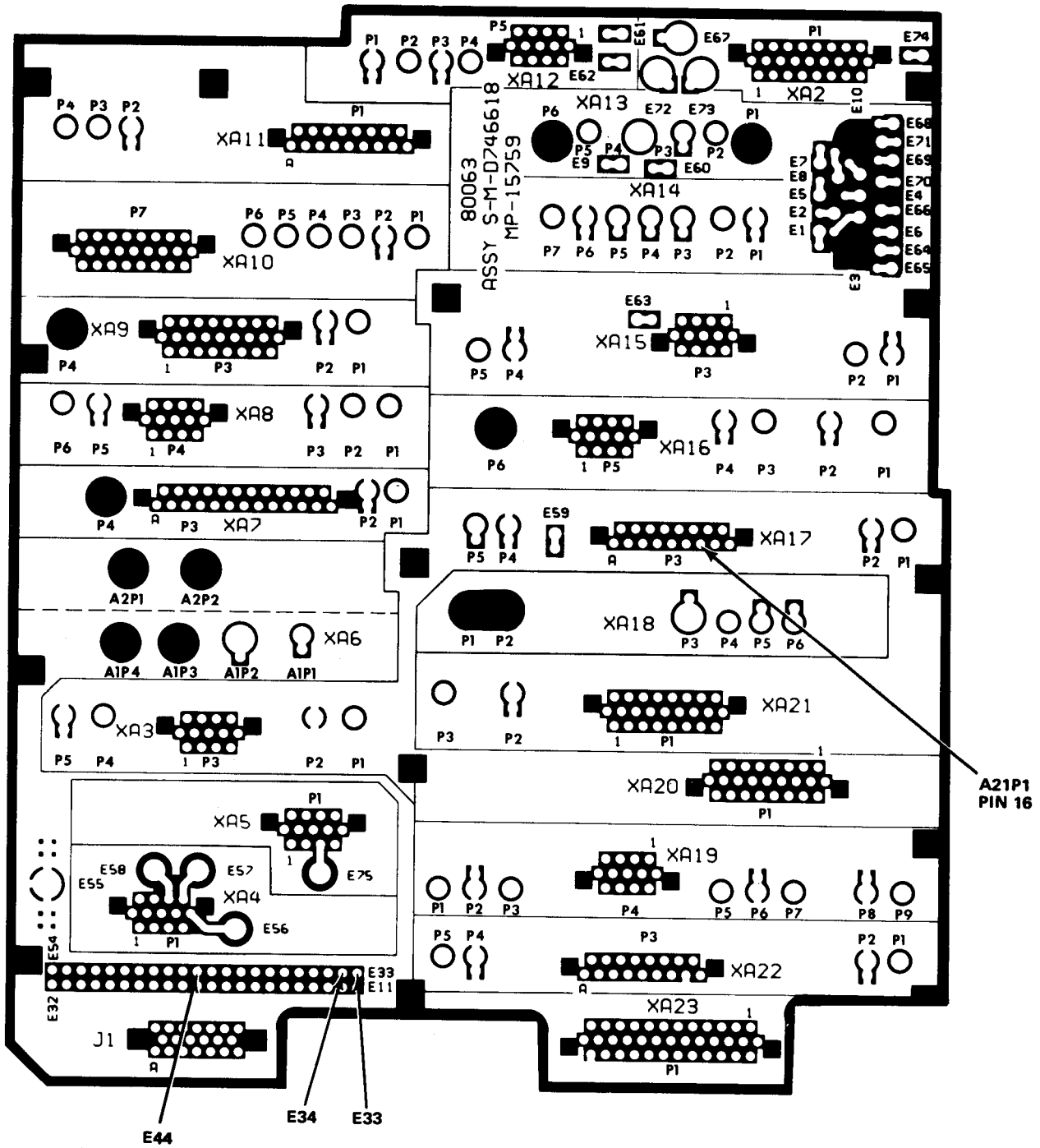

EL5WS086

Figure 4-46. Squelch/retransmit test point locations.

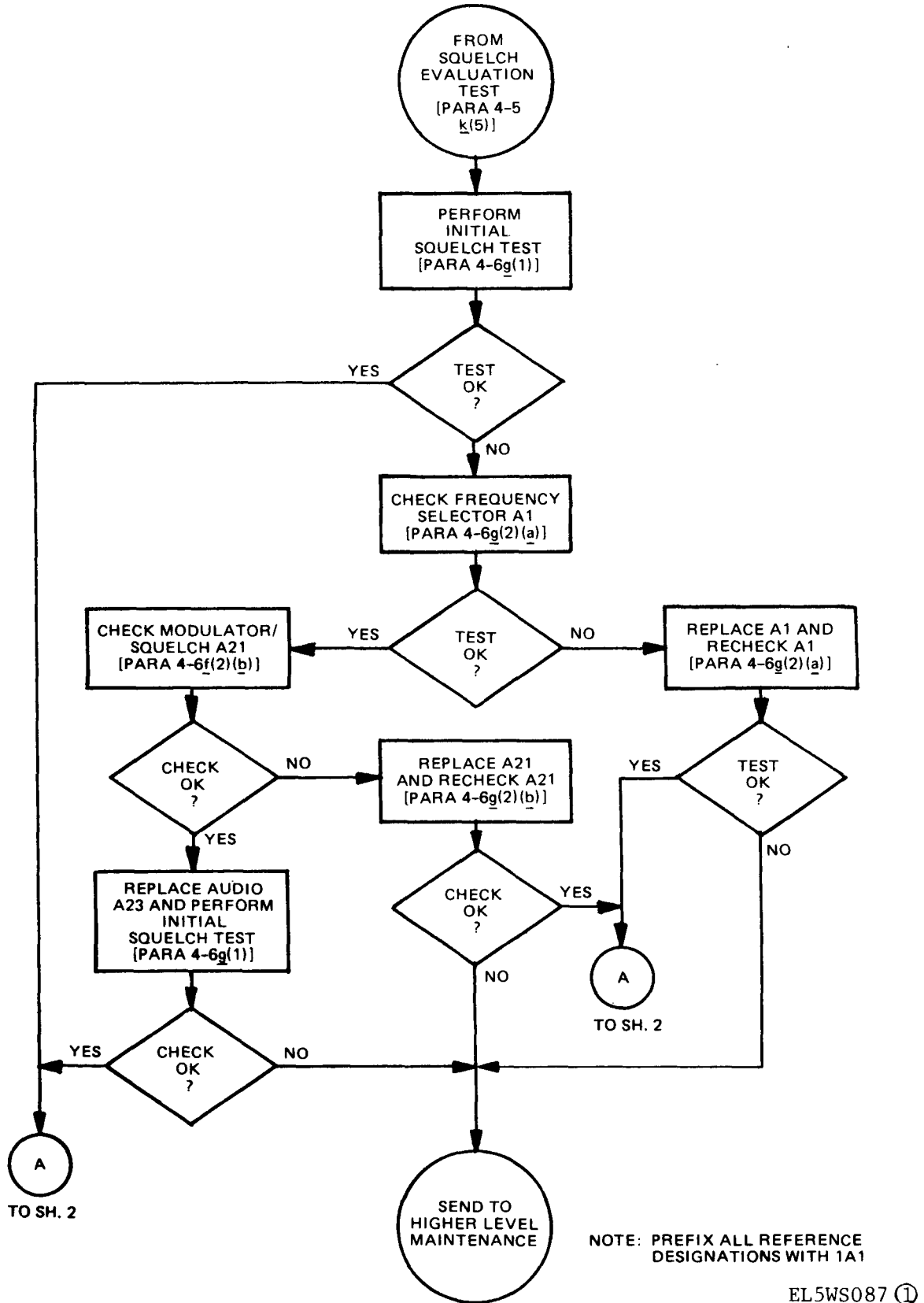
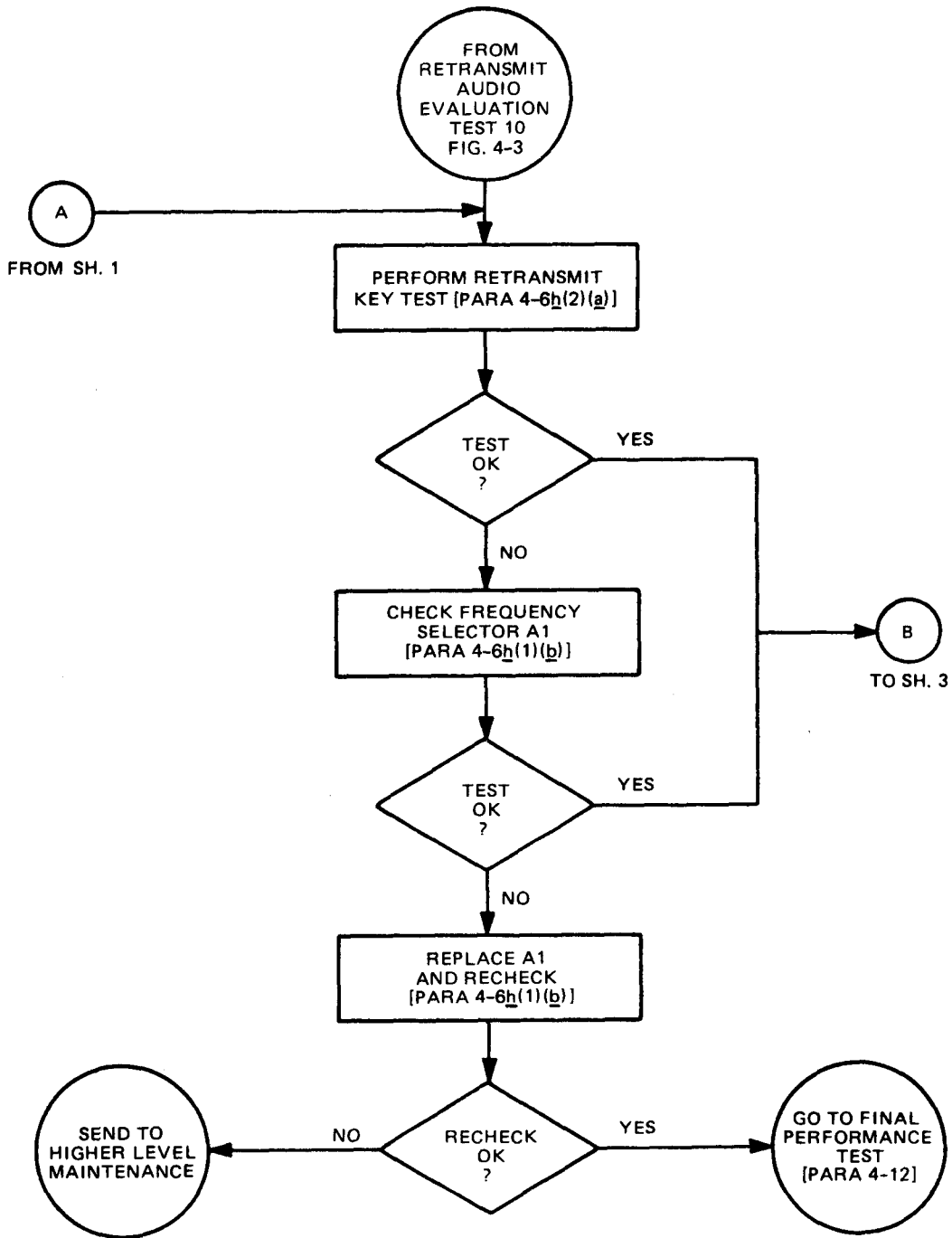

Figure 4-47. Squelch/retransmit troubleshooting diagram (sheet 1 of 3).



NOTE: PREFIX ALL REFERENCE DESIGNATIONS WITH 1A1

EL5WS087 ②

Figure 4-47. Squelch/retransmit troubleshooting diagram (sheet 2 of 3).

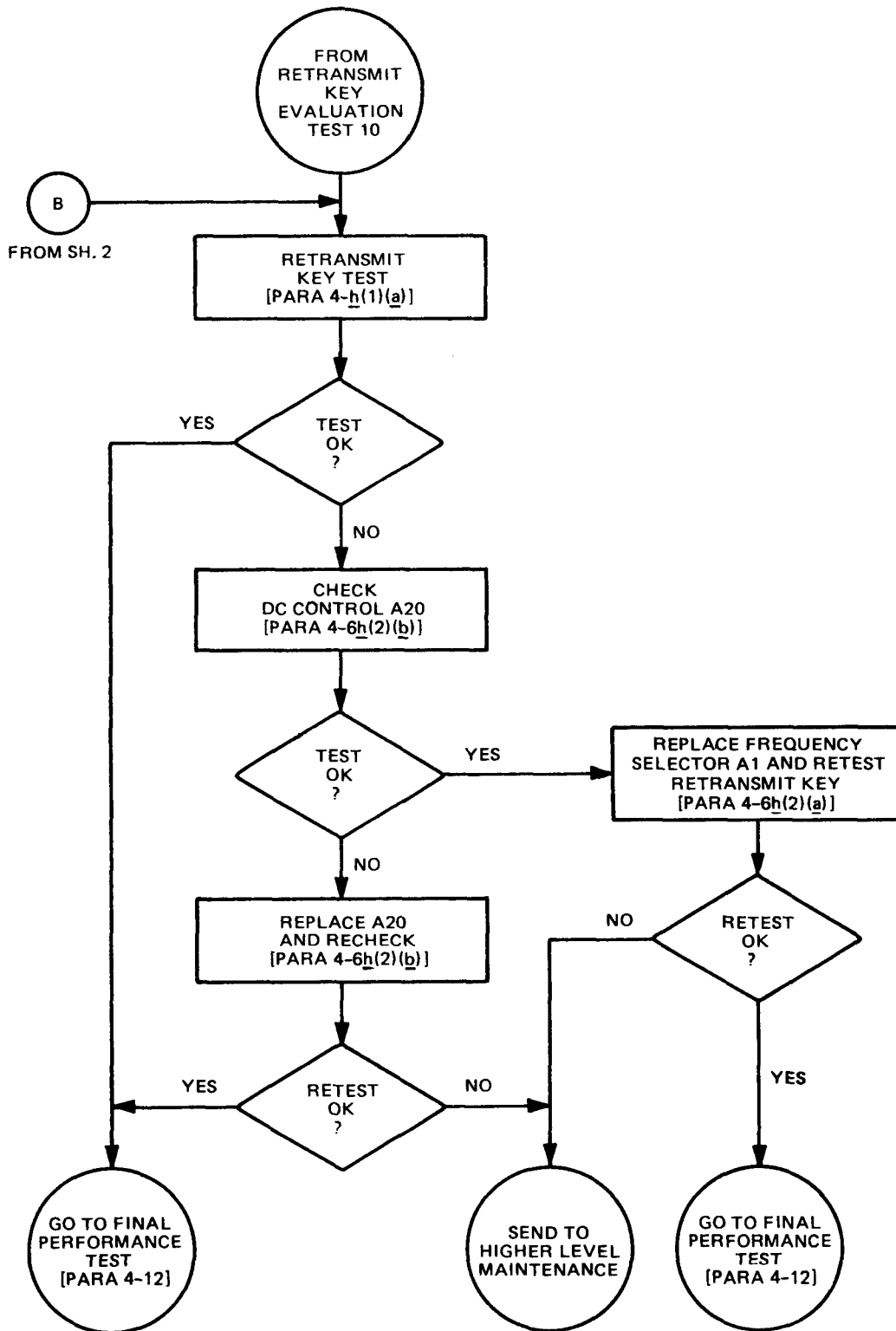

NOTE: PREFIX ALL REFERENCE DESIGNATIONS WITH 1A1

EL5WS087 ③

Figure 4-47. Squelch/retransmit troubleshooting diagram (sheet 3 of 3).

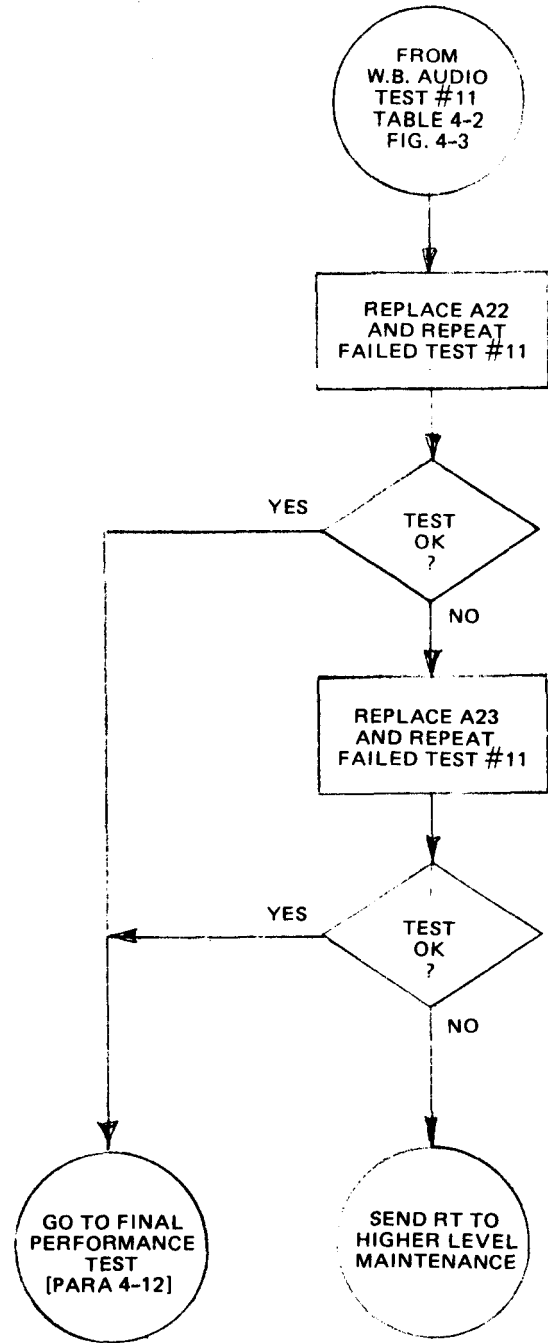

NOTE: PREFIX ALL REFERENCE DESIGNATIONS WITH 1A1

EL5WS088

Figure 4-48. Receive wideband audio troubleshooting diagram.

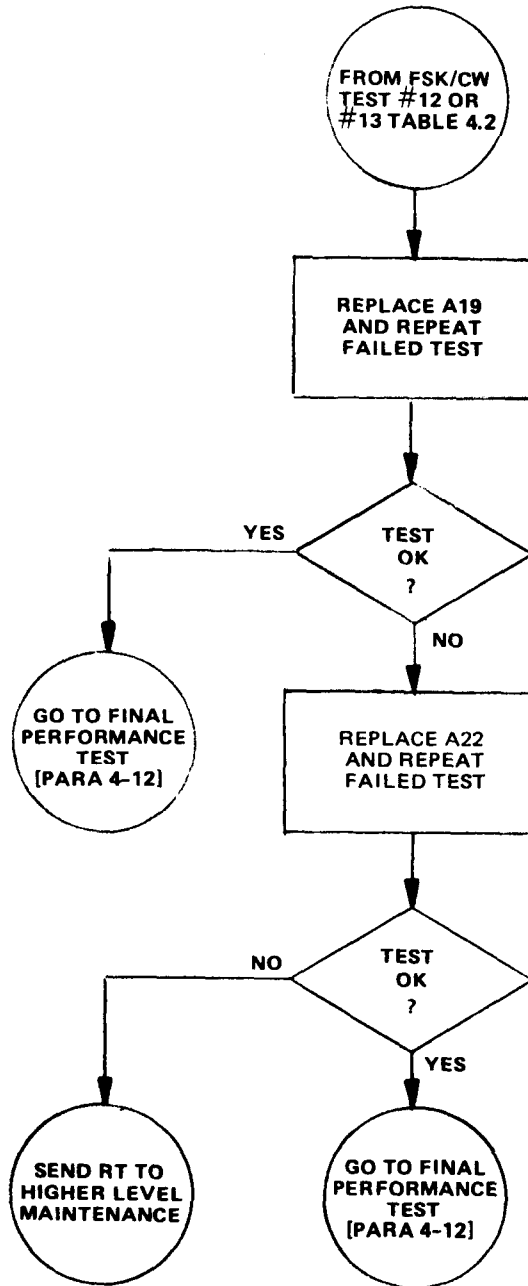

EL5WS089

Figure 4-49. Receive FSK/CW troubleshooting diagram.

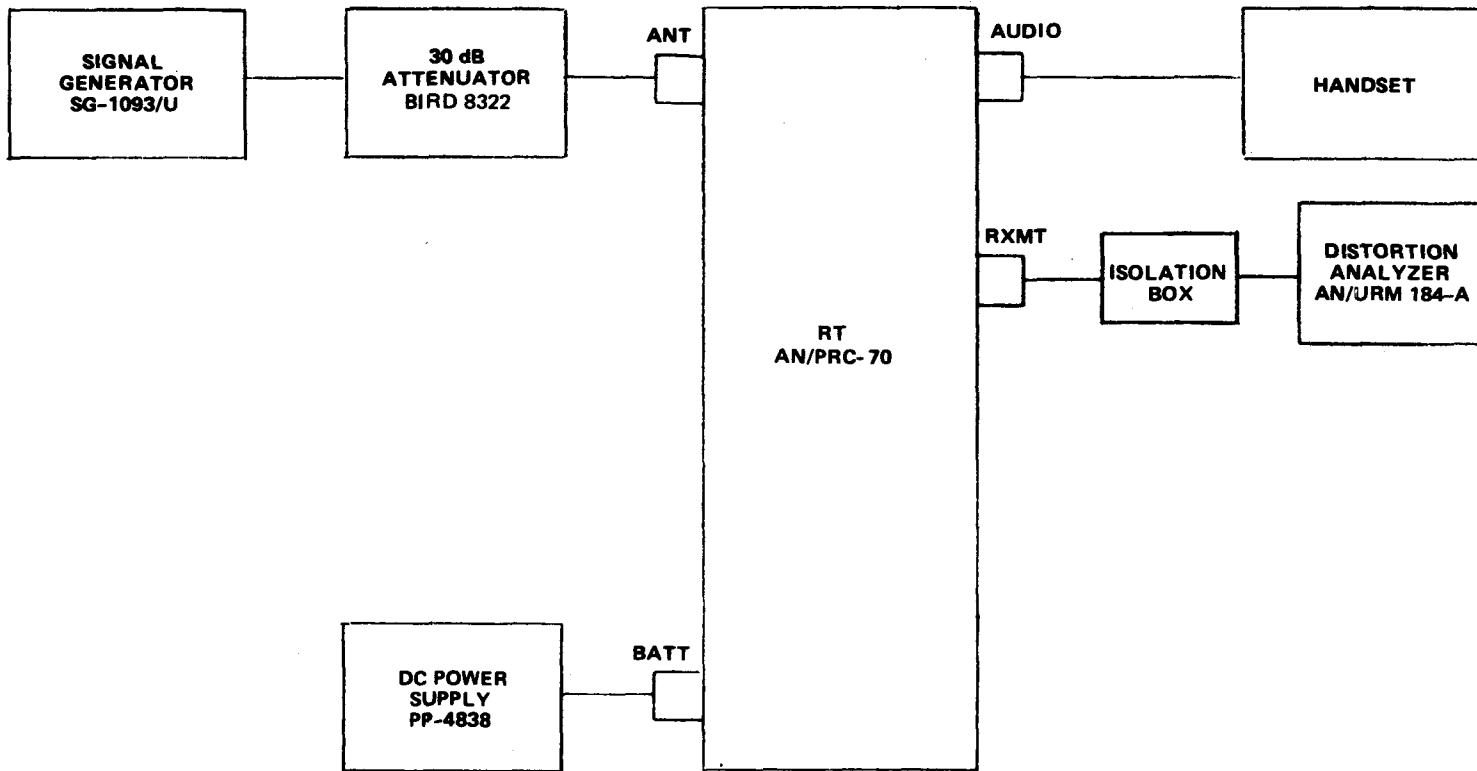

EL5WS090

Figure 4-50. Receive SINAD test setup.

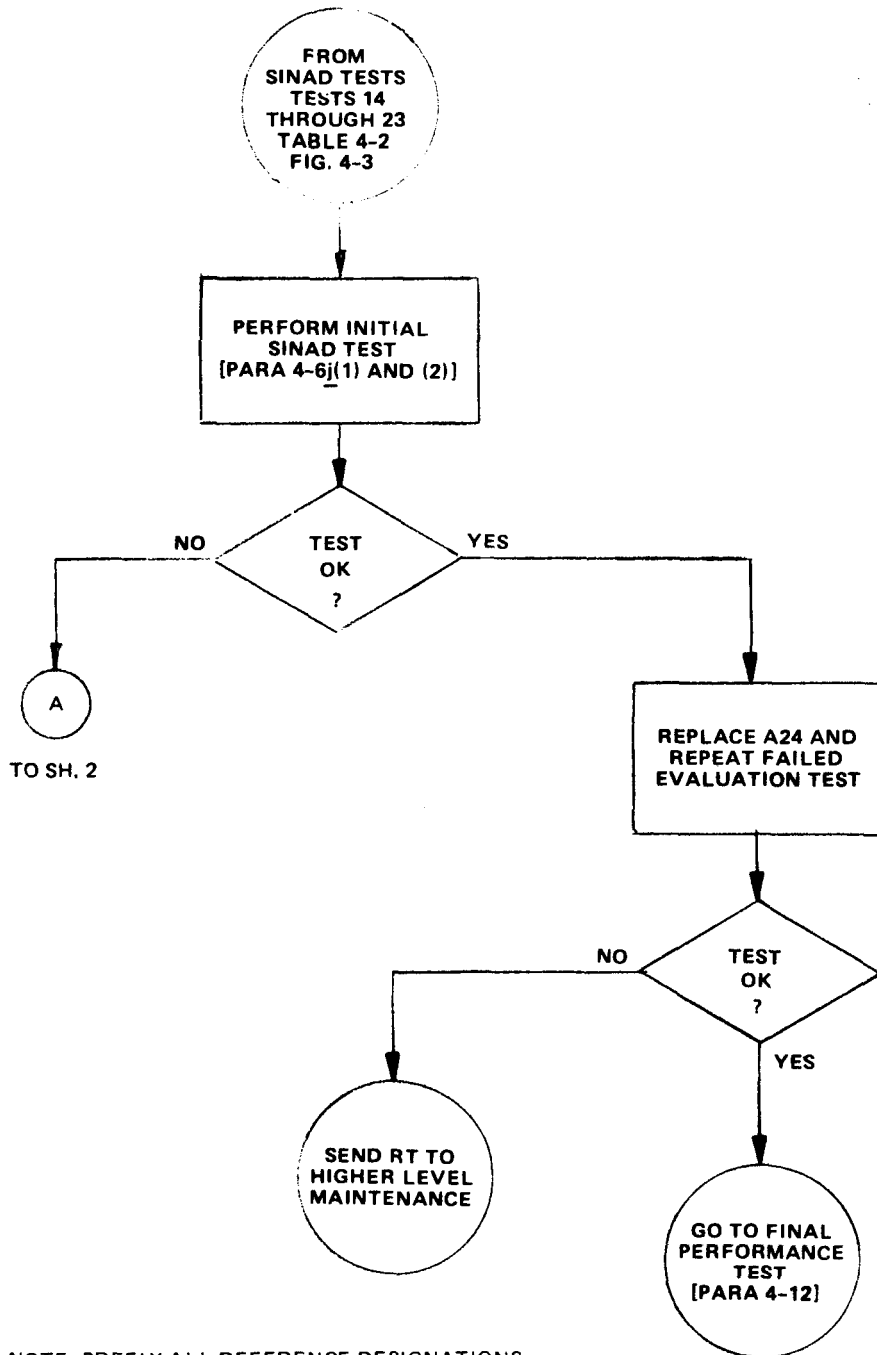

NOTE: PREFIX ALL REFERENCE DESIGNATIONS WITH 1A1.

EL5WS091 (1)

Figure 4-51. Receive SINAD troubleshooting diagram (sheet 1 of 3).

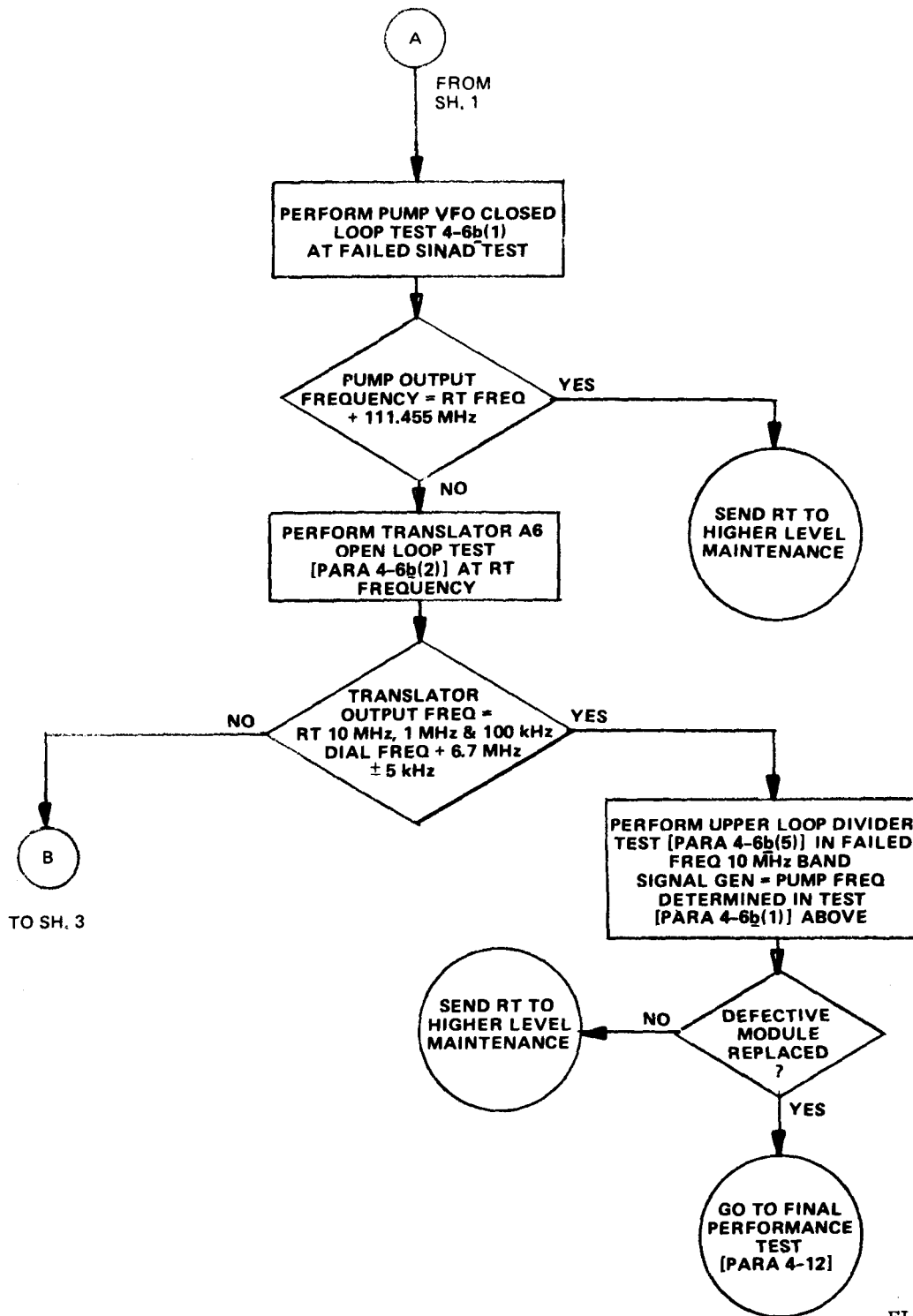

EL5WS091 ②

Figure 4-51. Receive SINAD troubleshooting diagram (sheet 2 of 3).

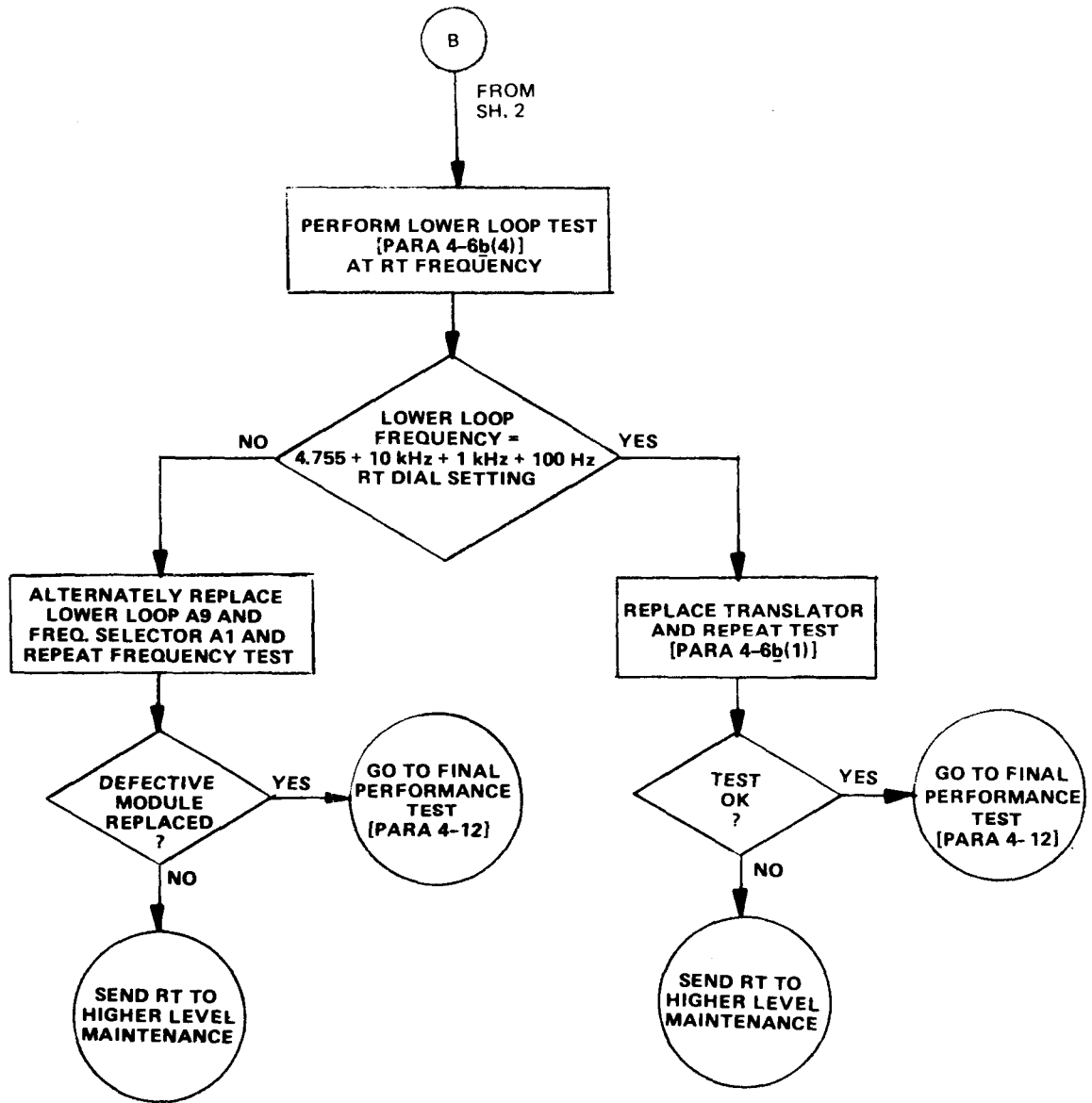

EL5WS091 ③

Figure 4-51. Receive SINAD troubleshooting diagram (sheet 3 of 3).

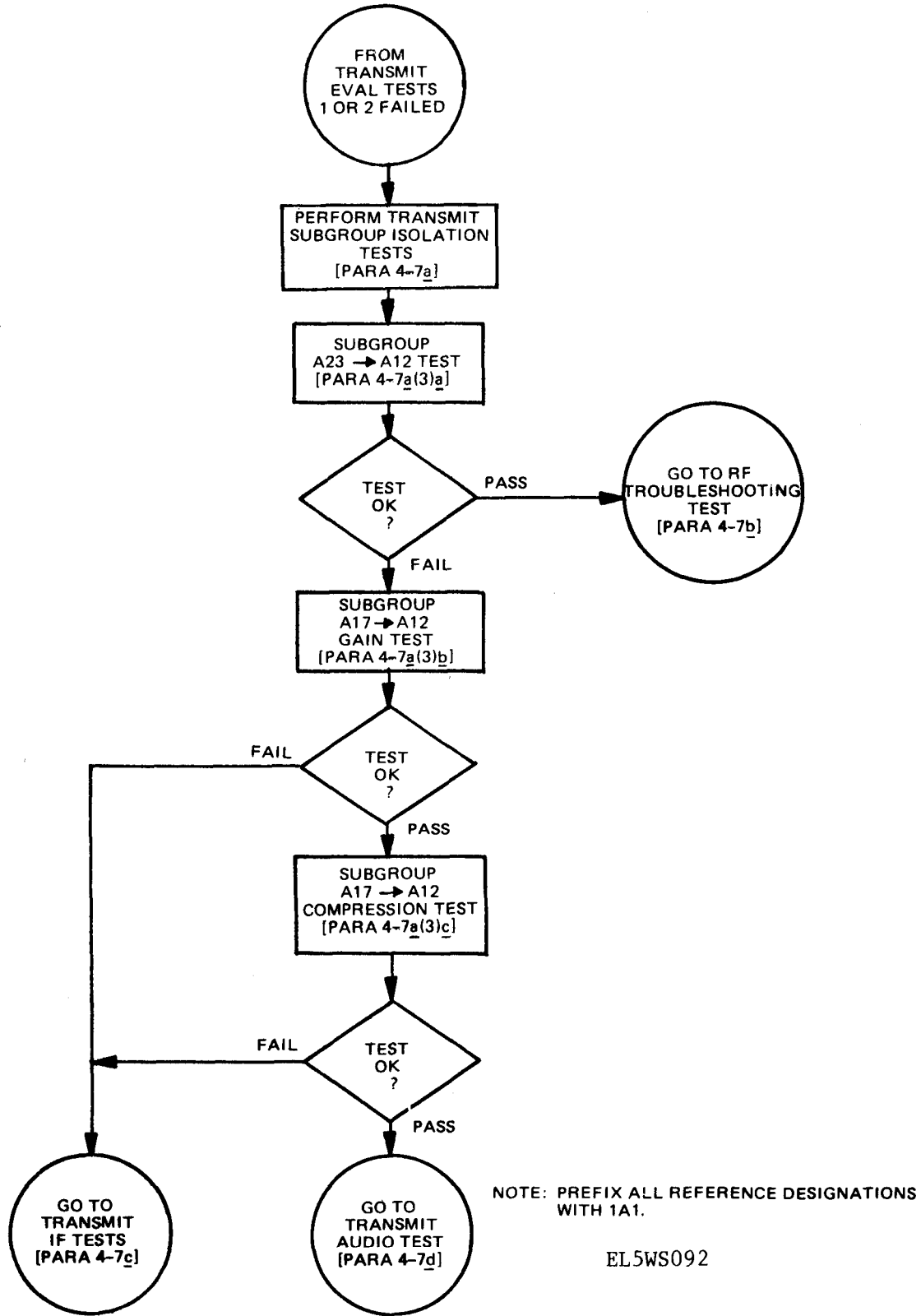
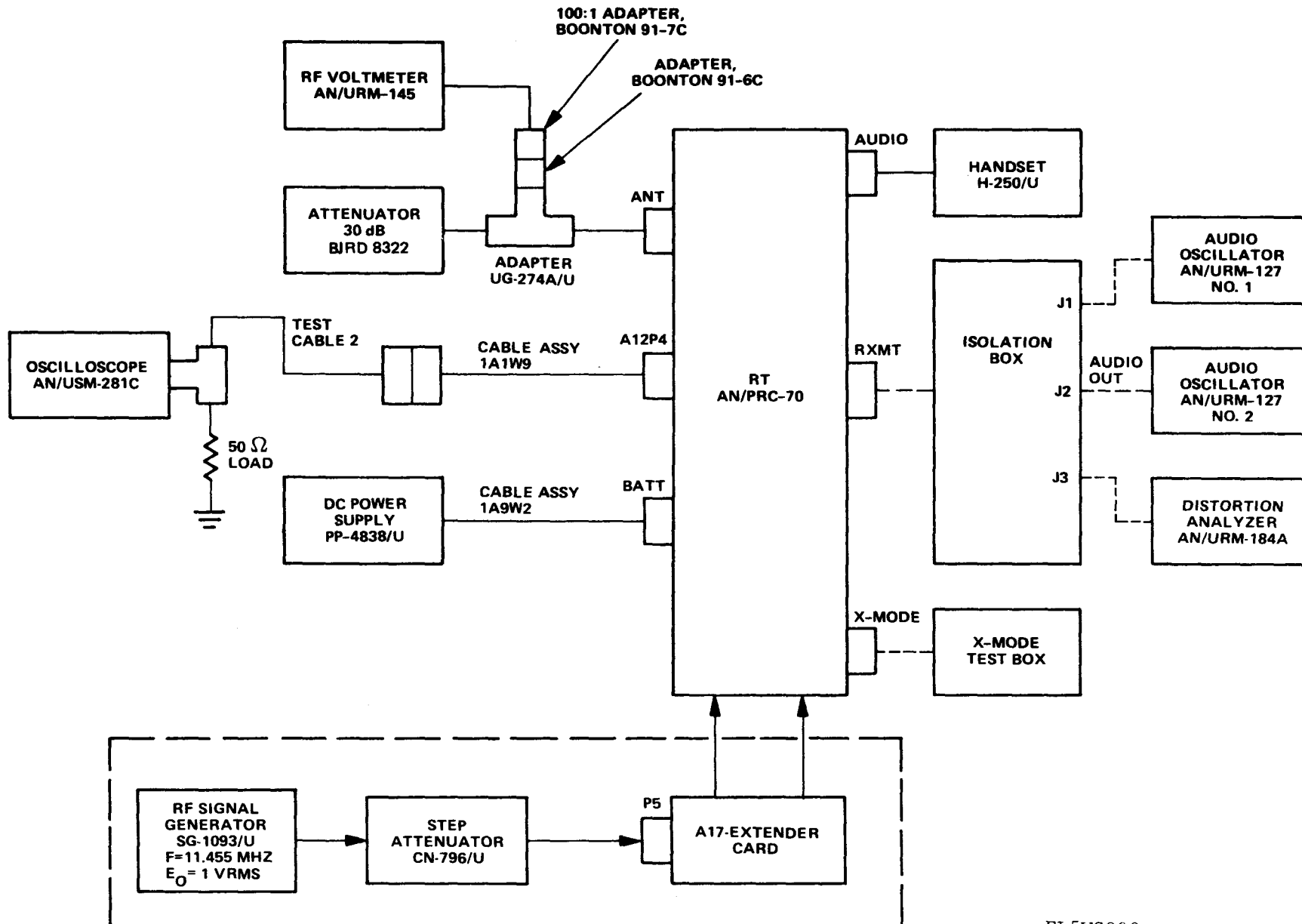
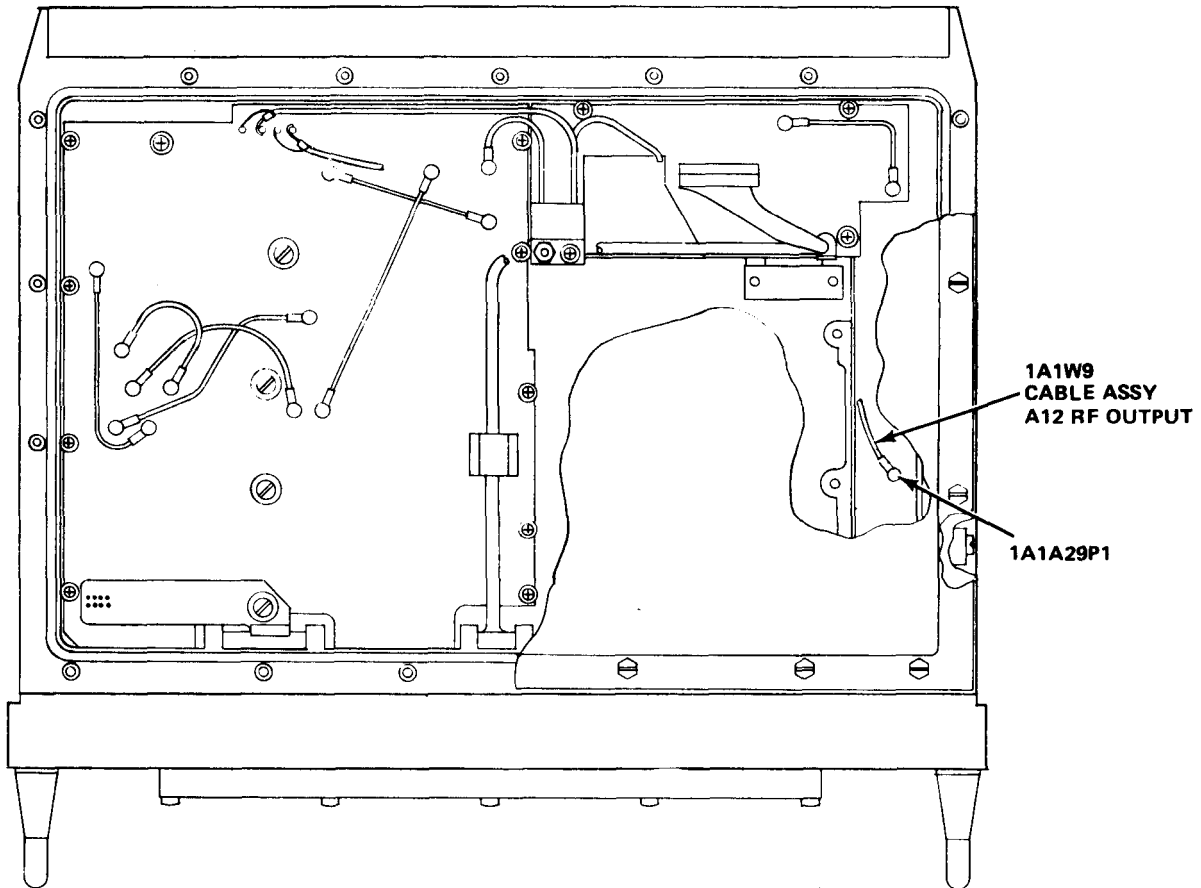

Figure 4-52. Transmit subgroup isolation flow diagram.



EL5WS093

Figure 4-53. Transmit subgroup isolation test setup.



BOTTOM VIEW

EL5WS094 ①

*Figure 4-54. Initial transmit signal path test point locations
(sheet 1 of 2).*

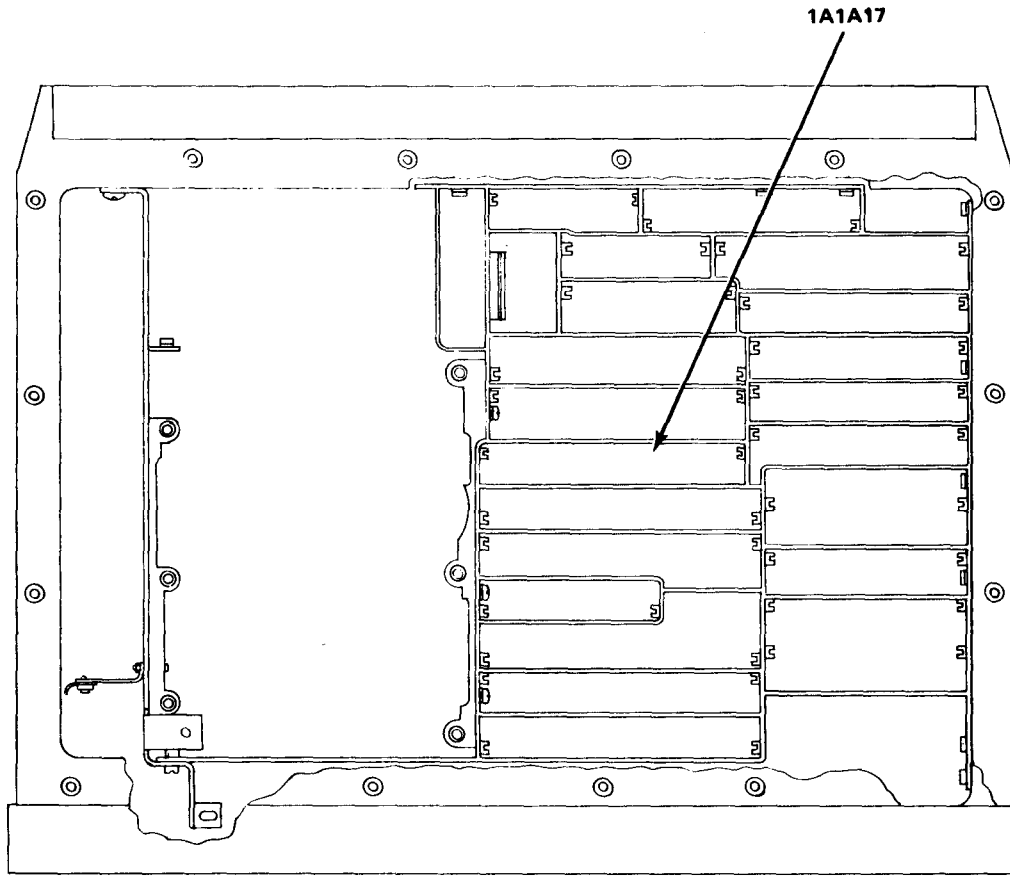

TOP VIEW

EL5WS094 ②

*Figure 4-54. Initial transmit signal path test point locations
(sheet 2 of 2).*

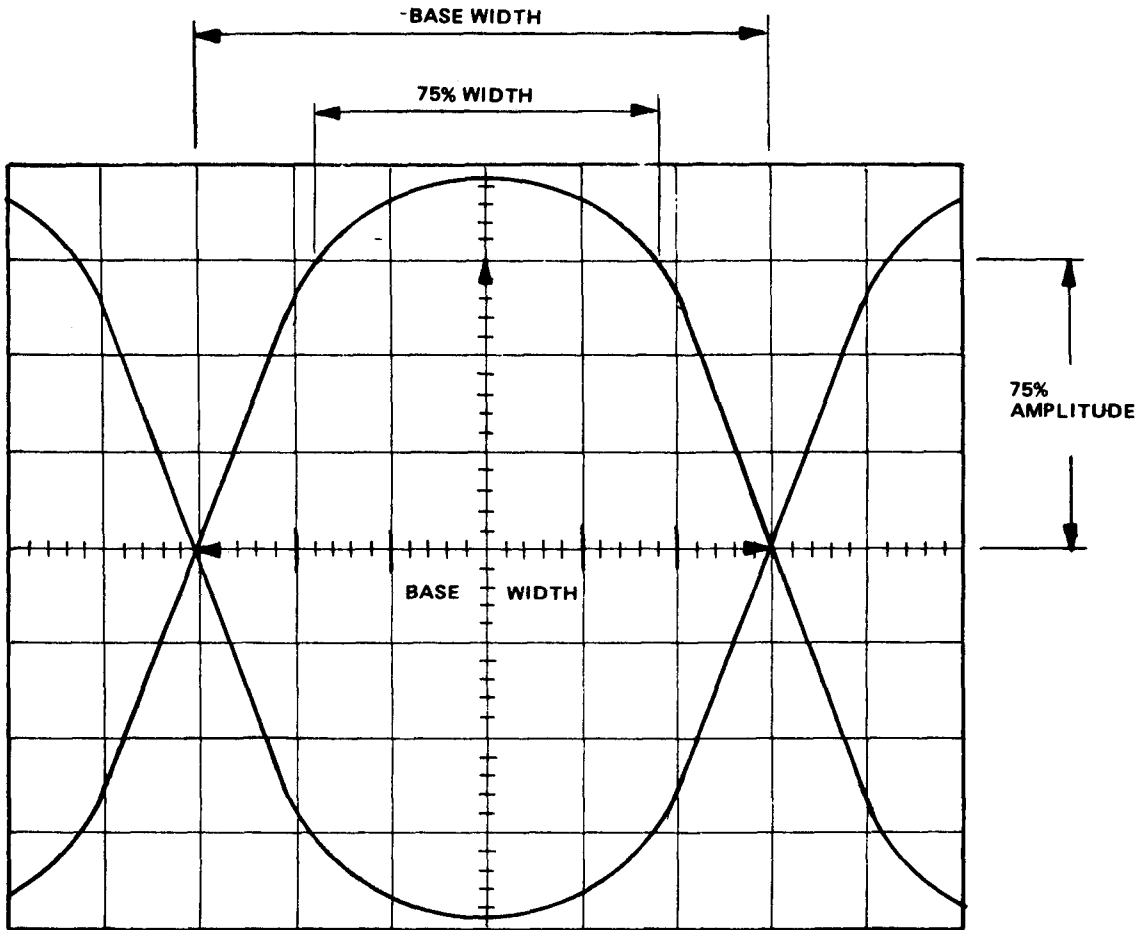

THE RATIO OF THE WIDTH AT 75% AMPLITUDE
TO THE BASE WIDTH MUST BE LESS THAN 0.6.

EL5WS095

Figure 4-55. Single side band distortion waveform.

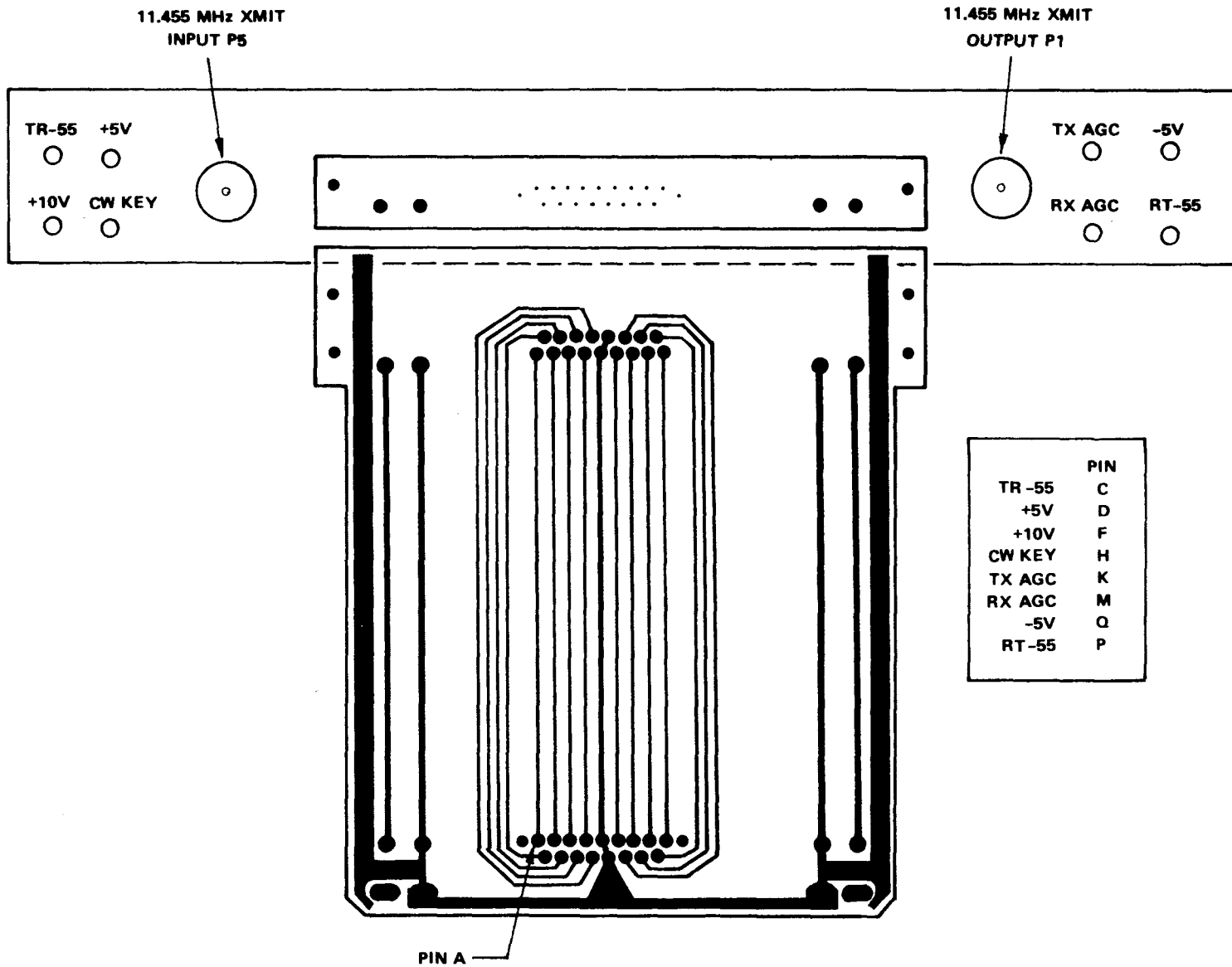

Figure 4-56. A17 extender card.

EL5WS096

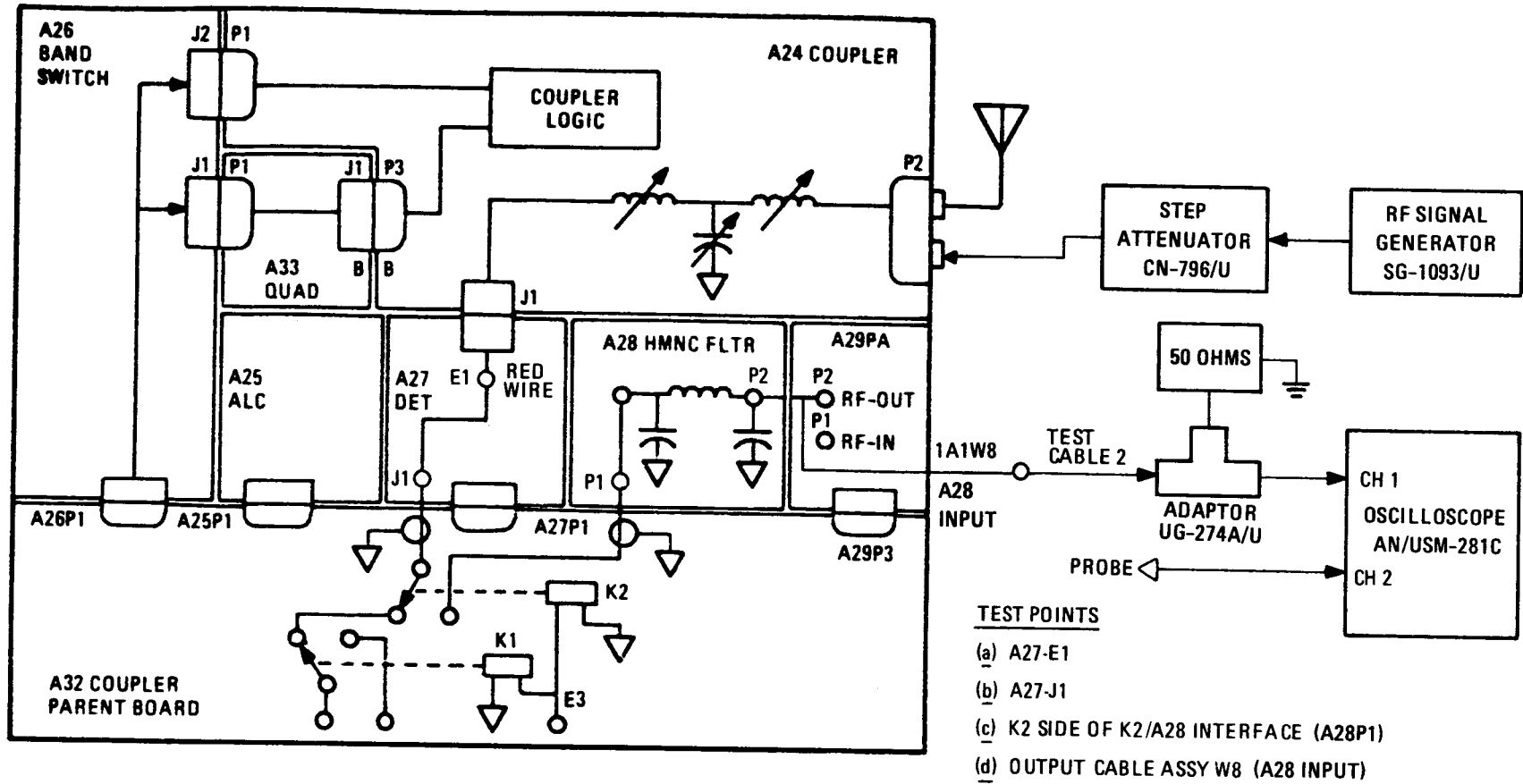
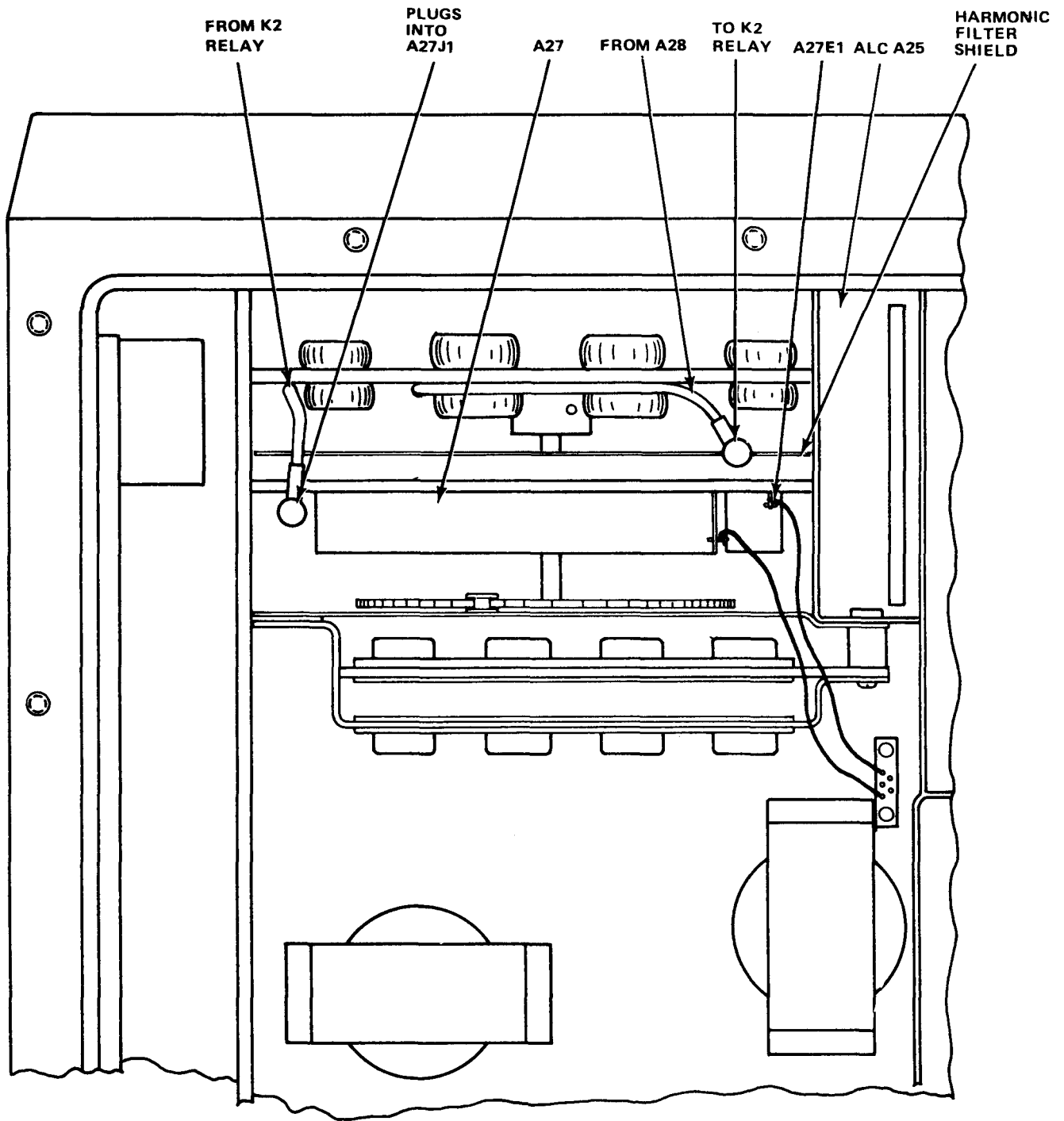

Figure 4-57. Transmit RF signal path test setup.

EL5WS097



EL5WS098 ①

Figure 4-58. Transmit RF signal path test point location (sheet 1 of 2).

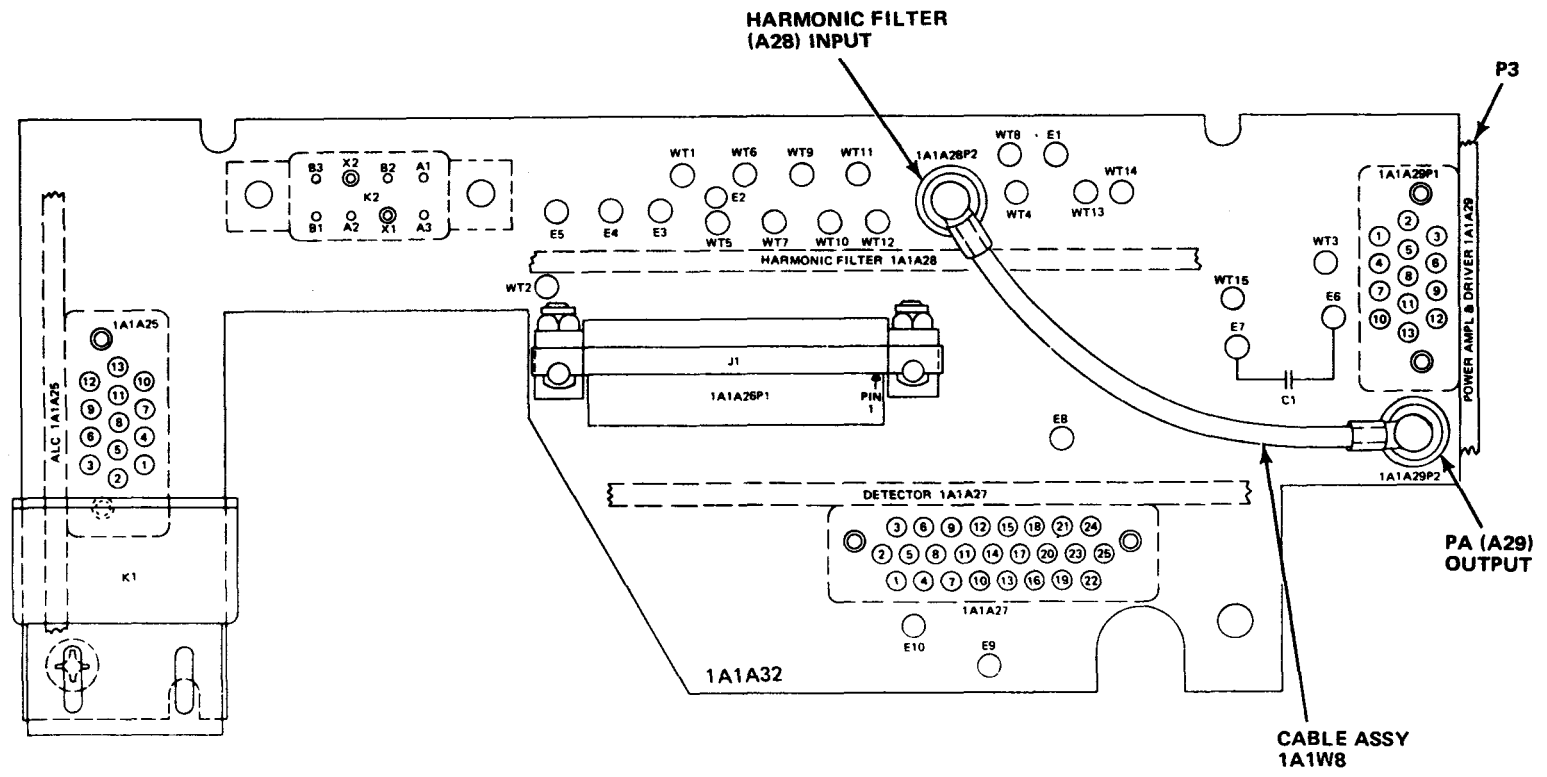

EL5WS098 (2)

Figure 4-58. Transmit RF signal path test point location (sheet 2 of 2).

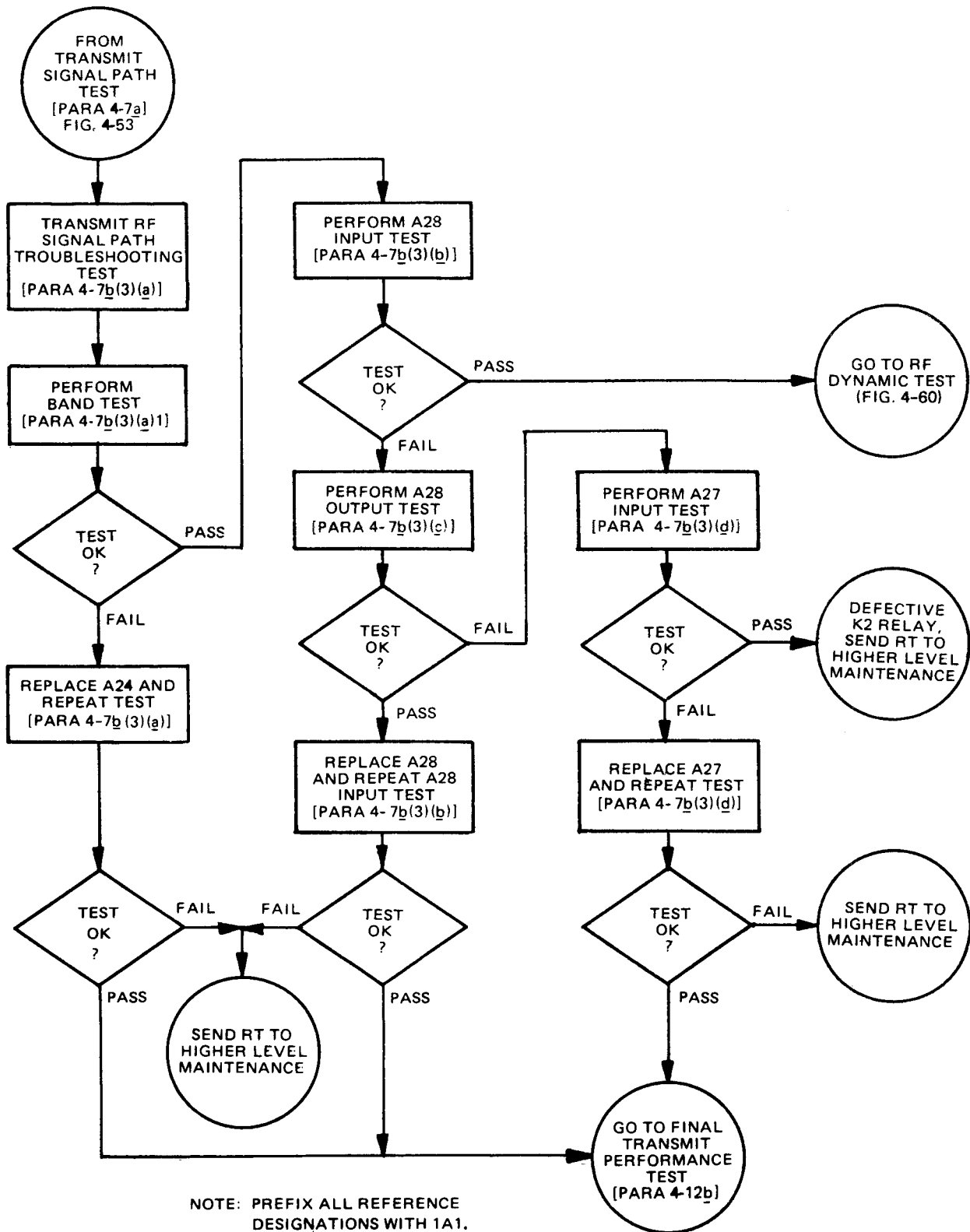

EL5WS099

Figure 4-59. Transmit RF signal path troubleshooting diagram.

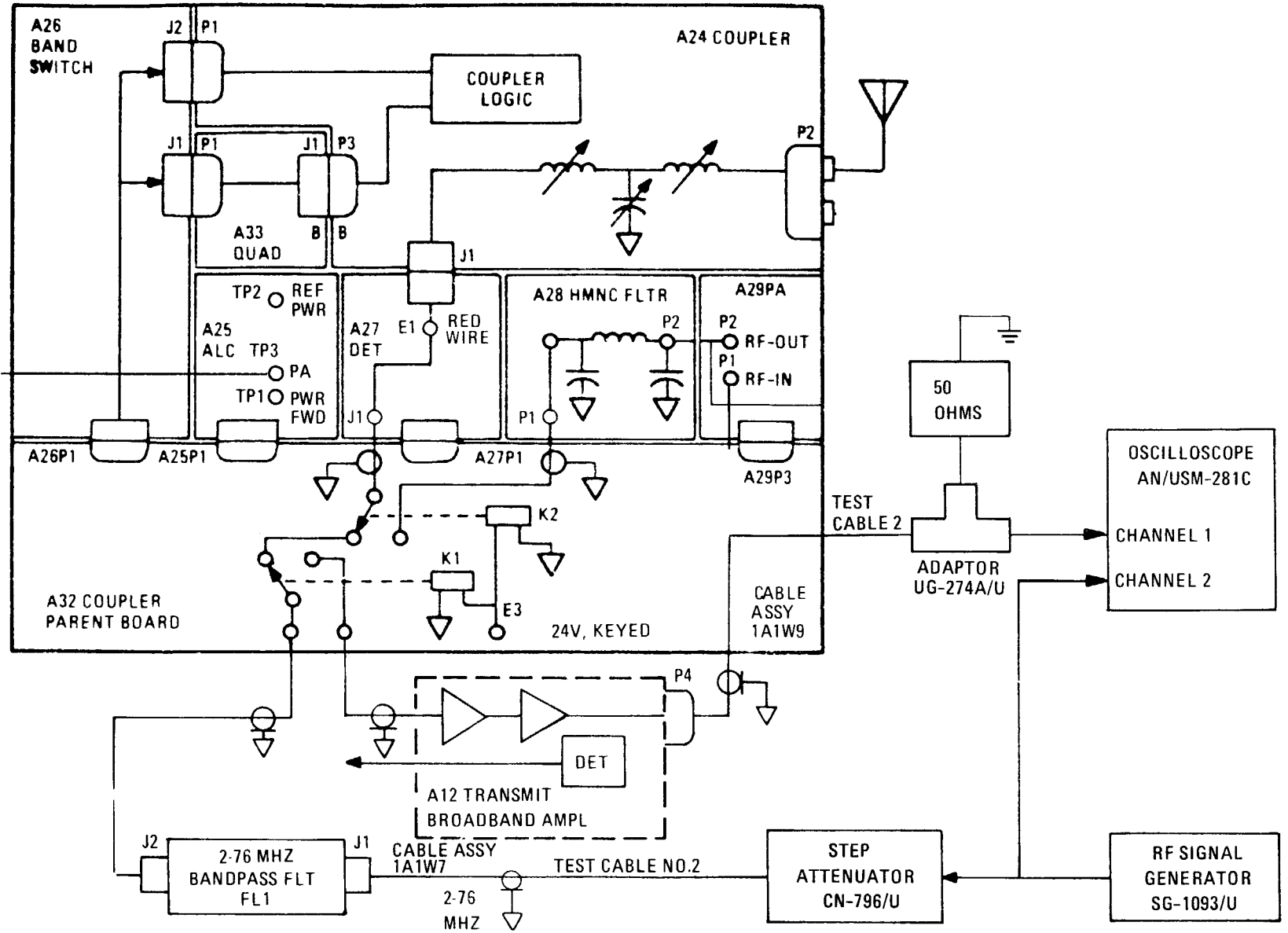

EL5WS100

Figure 4-60. Transmit RF dynamic test setup diagram.

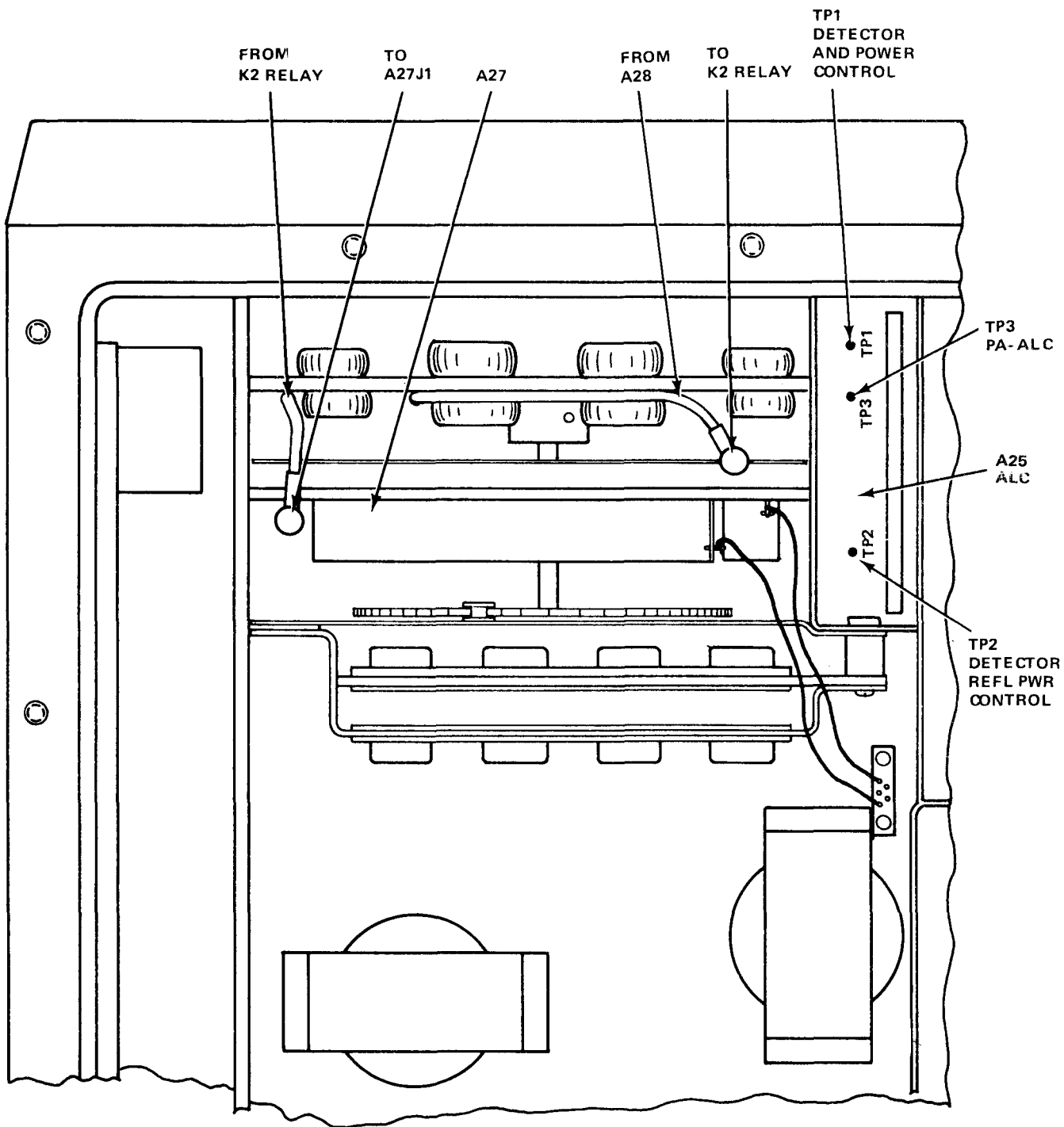

EL5WS101 ①

Figure 4-60.1. Transmit RF dynamic test point location guide (sheet 1 of 2).

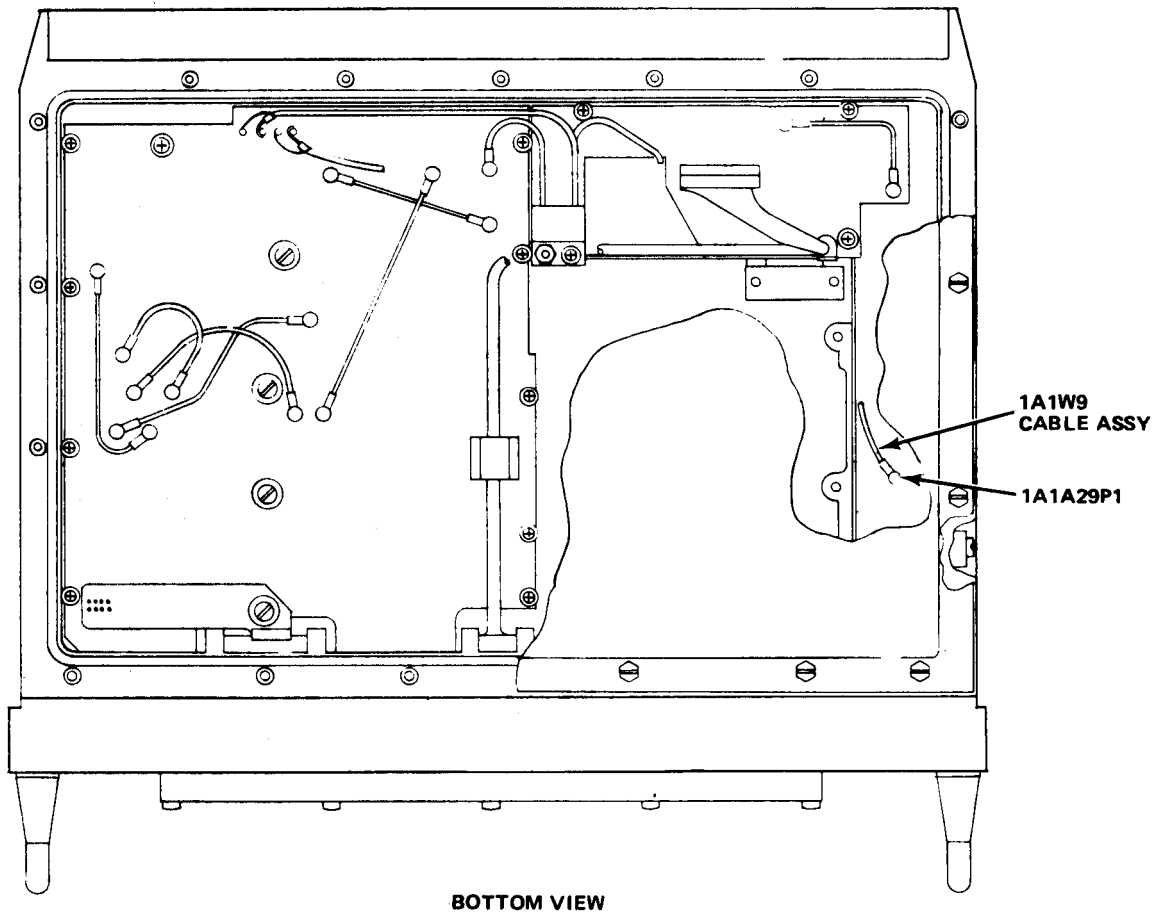

EL5WS101 ②

**Figure 4-60.1. Transmit RF dynamic test point location guide
(sheet 2 of 2).**

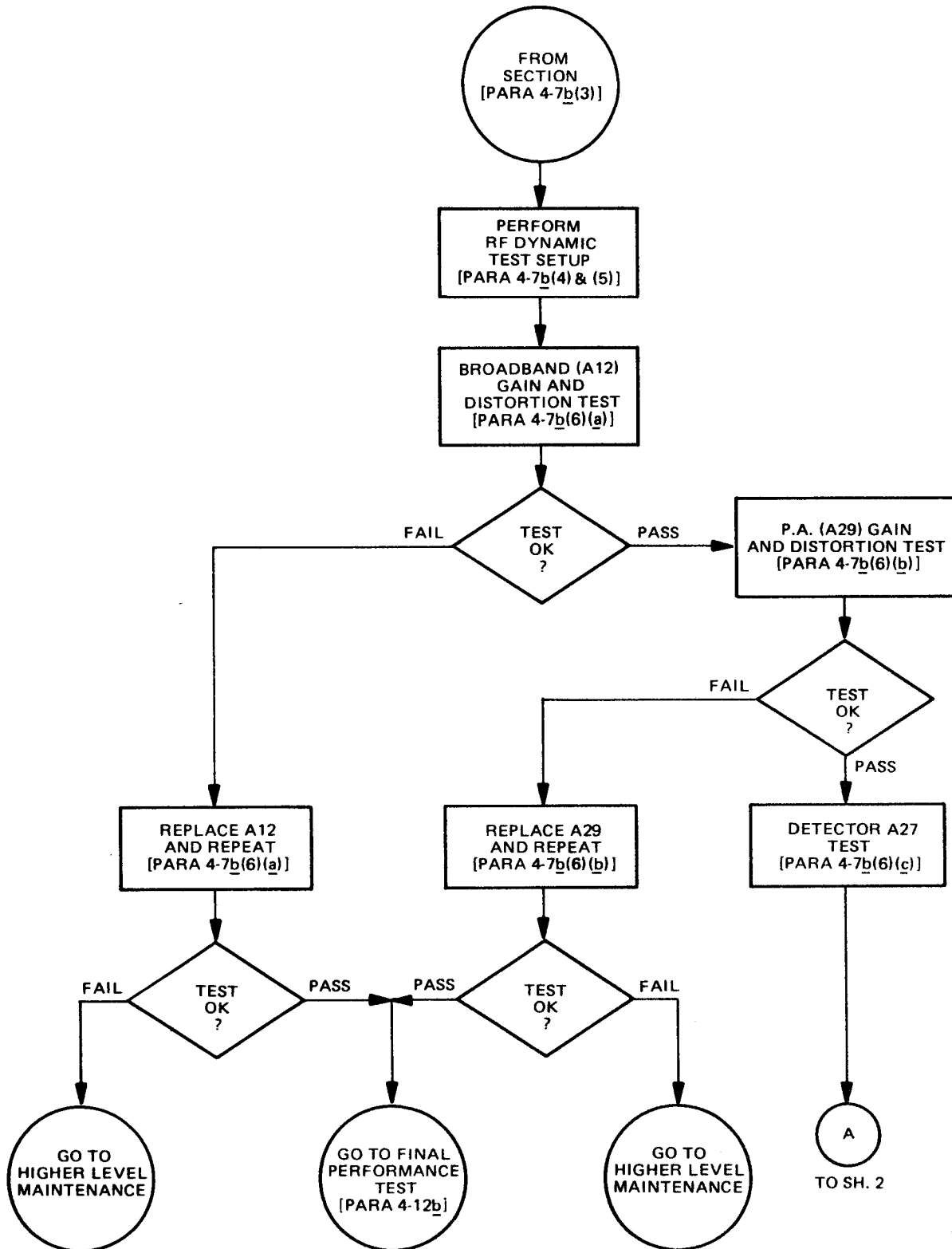

NOTE: PREFIX ALL REFERENCE DESIGNATIONS WITH 1A1

EL5WS102 ①

Figure 4-61. Transmit RF dynamic test troubleshooting diagram (sheet 1 of 2).

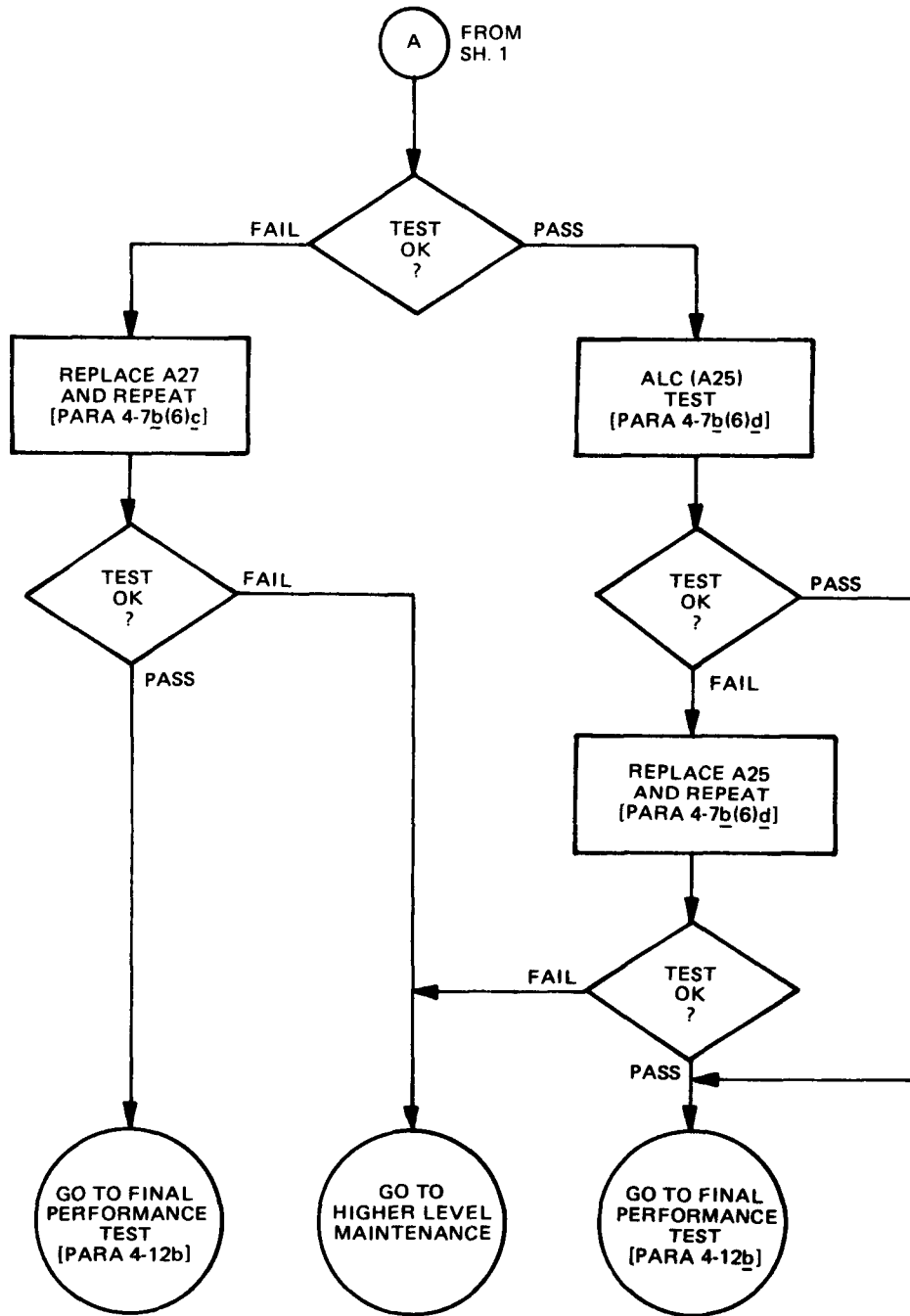

NOTE: PREFIX ALL REFERENCE DESIGNATIONS WITH 1A1

EL5WS102 ②

Figure 4-61. Transmit RF dynamic test troubleshooting diagram (sheet 2 of 2).

- (b) Set the Generator controls to:
 FREQUENCY - 2.1500 MHZ
 MODULATION - AM
 MODULATION FREQUENCY - 1 KHZ
 RF OUTPUT RANGE - 1.0 VOLT
 RF OUTPUT VERNIER - CCW

(6) *RF dynamic troubleshooting tests.* See figure 4-61 for troubleshooting diagram.

(a) *Broadband gain and distortion test.*

1. Connect equipment as shown in figure 4-60.

2. Set Signal Generator to 2.1500 MHz and 100 percent modulation at a modulation frequency of 1 kHz AM.

3. Set RF output to 300 mV.

4. Monitor Signal Generator as level is changed, adjusting modulation level to maintain 100 percent modulation (see fig. 4-62).

5. Set Step Attenuator to 33 db.

6. Set RT POWER control to LO PWR and FREQUENCY control to 2.1500 MHz.

7. Key the RT. Monitor oscilloscope channel 1 and slowly change signal generator output level until Oscilloscope waveform amplitude reads 4.5 V p-p.

8. Check signal generator modulation (on channel 2) and readjust to 100 percent, if necessary.

9. Check A12 output on channel 1 and adjust signal generator output to obtain 4.5 ± 0.1 V p-p. Test fails if signal generator exceeds 1.1 V rms.

10. Set step attenuator to 30 dB.

11. Note that RF output on oscilloscope is greater than 6.0 V p-p.

12. Check to see that signal distortion ratio as determined in figure 4-62 does not exceed 42 percent (see fig. 4-62).

13. Unkey the RT.

14. Set step attenuator to 33 dB.

(b) *Power amplifier gain and distortion test.*

1. Connect equipment as shown in figure 4-62.1.

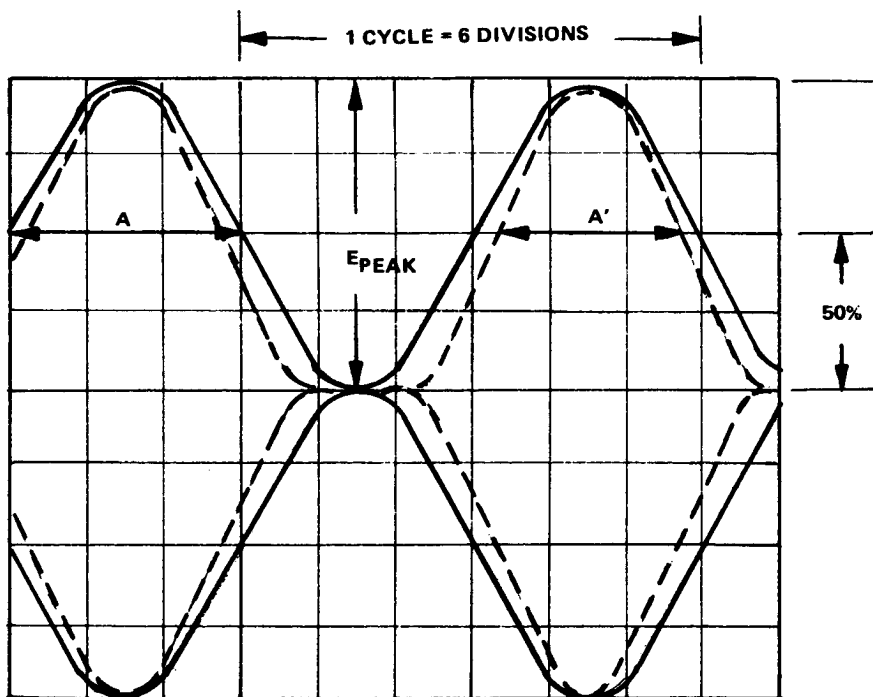

SCOPE CONTROL SETTINGS

- (1) COURSE TIME BASE = 100 μ s/DIV.
- (2) VARIABLE TIME BASE SO THAT 6 DIVISIONS = 1 CYCLE.
- (3) SCOPE AMPLITUDE FOR FULL SCALE SIGNAL DISPLAY.
- (4) DISTORTION RATIO = PULSE WIDTH AT 50% E_{PEAK} (DIV)

 NUMBER DIVISIONS PER CYCLE
- (5) DASHED TRACE REPRESENTS A DISTORTION RATIO OF \approx 42%.

SIGNAL GENERATOR SETTINGS

MODULATING FREQUENCY TO 1 KHZ.

AM MODULATION CONTROL UNTIL THE GENERATOR TRACE OUTPUT (MONITOR SIGNAL) MINIMUM SIGNAL LEVELS JUST TOUCH.

SOLID TRACE REPRESENTS A 100% AM MODULATION SIGNAL.

EL5WS103

Figure 4-62. 100% AM modulated RF signal.

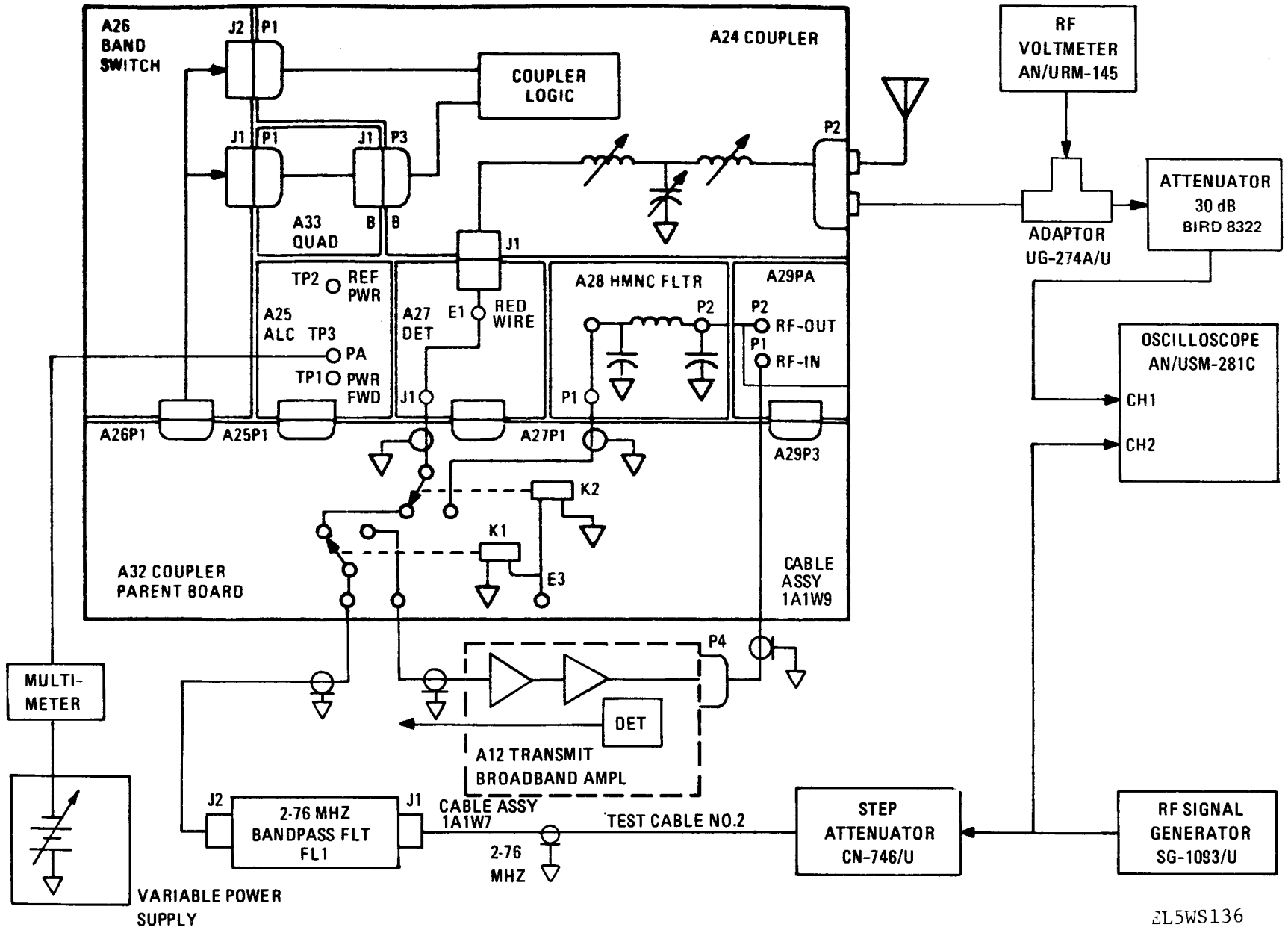

Figure 4-62.1 Transmit RF dynamic test setup (part 2) diagram.

EL5WS136

2. Set variable power supply to zero output voltage.

3. Ensure signal generator is at same level as in paragraph 4-7b(6)(a).

4. Ensure step attenuator is set to 33 dB.

5. Set RT POWER control to LO PWR.

6. Key the RT.

7. Adjust variable power supply until RF output reads 12 V ac on RF voltmeter.

8. Read current on 24V power supply ammeter. It should be less than 2.5 amperes.

9. Measure variable power supply output voltage. Test limit is 2.5 and 5.5 V dc.

10. Unkey the RT, and set variable power supply to zero output voltage.

11. Set RT POWER switch to HI PWR.

12. Key the RT.

13. Adjust variable power supply until RF output is 40.0 V ac, as read on RF voltmeter. At this point, power supply output voltage should be between 2.5 and 5.5 V dc.

14. Read current on power supply ammeter. It should be less than 7.0 amperes.

15. Set step attenuator to 36 dB.

16. Check to see that the signal distortion ratio per figure 4-62 does not exceed 42 percent. Test passes if ratio is between 42 and 58 percent.

17. Unkey the RT, and set variable power supply to zero output voltage.

(c) *Detector Test, A27.*

1. Connect equipment as shown in figure 4-62.1.

2. Set variable power supply to zero output voltage.

3. Ensure signal generator is at same level as in paragraph 4-7b(6)(a).

4. Ensure step attenuator is set to 33 dB.

5. Set RT for POWER control to LO PWR.

6. Key the RT.

7. Adjust variable power supply until RF output reads 12.0 V ac on RF voltmeter.

8. Using oscilloscope, measure voltage at TP1 on 1A1A25, see figure 4-60.1. Peak output should read 5.3 ± 1.0 V dc.

9. Measure voltage at TP2 on 1A1A25 with oscilloscope. Peak output should read less than 0.7 V dc.

10. Unkey the RT, and set variable power supply to zero output voltage.

11. Set RT POWER control to HI PWR.

12. Key the RT.

13. Adjust variable power supply until RF output is 40.0 V ac, as read on RF voltmeter.

14. Measure voltage at TP1 on 1A1A25 with oscilloscope. Peak output should read 5.3 ± 1.0 V dc.

15. Measure voltage at TP2 on 1A1A25 with oscilloscope. Peak output should read less than 0.7 V dc.

16. Unkey the RT.

(d) *ALC Test, A25.*

1. Connect equipment as shown in figure 4-62.1.

2. Remove variable power supply.

3. Ensure signal generator is at same level as in paragraph 4-7b(6)(a).

4. Ensure step attenuator is set to 33 dB.

5. Set RT POWER control to LO PWR.

6. Key the RT.

7. Using RF voltmeter, measure RF output level. Reading should be between 9.0 and 15.0 V. Record this output level.

8. Set step attenuator to 30 dB.

9. Using RF voltmeter, measure RF output level. Reading should not change more than 0.5 V from the level read in step 7 above.

10. Unkey the RT.

c. *Transmit IF Signal Path Troubleshooting Tests,*

(1) *Transmit IF signal path test setup (see fig. FO-11).*

(a) *Equipment setup.*

1. Setup equipment as shown in figure 4-63.

(2) *RT and equipment control settings.*

(a) *RT control settings.*

1. POWER - LO PWR

2. MODE - SSB

3. FREQUENCY - 2.1500 MHz

4. SQUELCH - OFF

(b) *Equipment control settings.*

1. Adjust Power Supply to $+24 \pm 0.5$ V dc output.

2. Unplug module A19.

3. Connect Step Attenuator (set to 50 dB) to 1A1A17P5.

4. Connect Signal Generator to Step Attenuator.

5. Set Signal Generator to 11.4550 MHz ± 10 Hz, and output level of 1.0 V.

6. Connect 1A1A17 Extender Card pin K to ground.

(3) *Transmit IF signal path test.*

1. Set Step Attenuator to 50 dB.

2. Key RT.

3. Using probe, check to see that signal level at XA15P2 is more than 65 mV rms (use RF voltmeter).

4. Unkey RT.

(b) *DC Control 1A1A20 output test.*

1. Check to see that the CW Key Line output at XA20, pin 10, is less than 0.5 V dc on Multimeter (see fig. 4-65).

(c) *Phase Detector 1A1A8 out of lock test.*

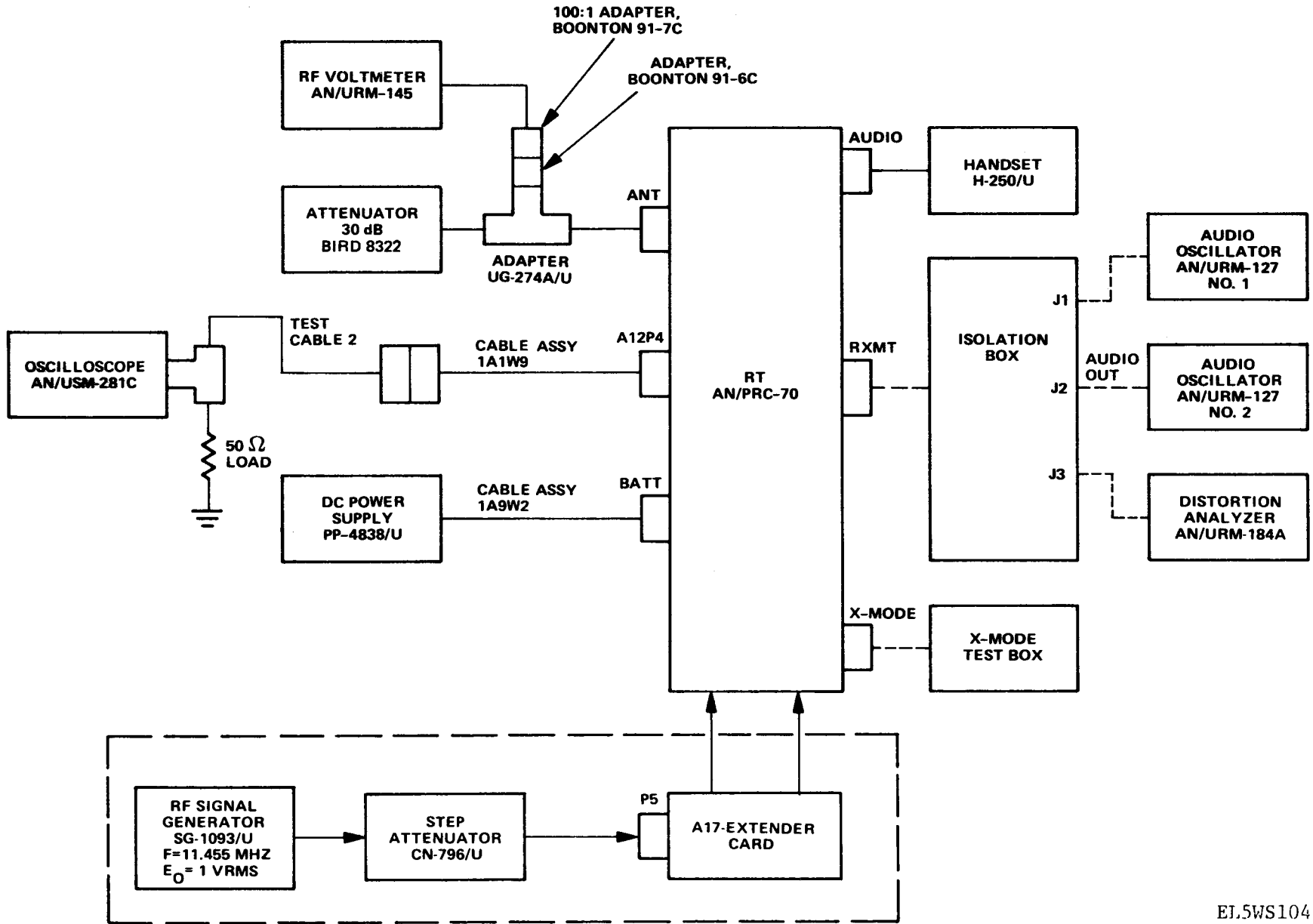
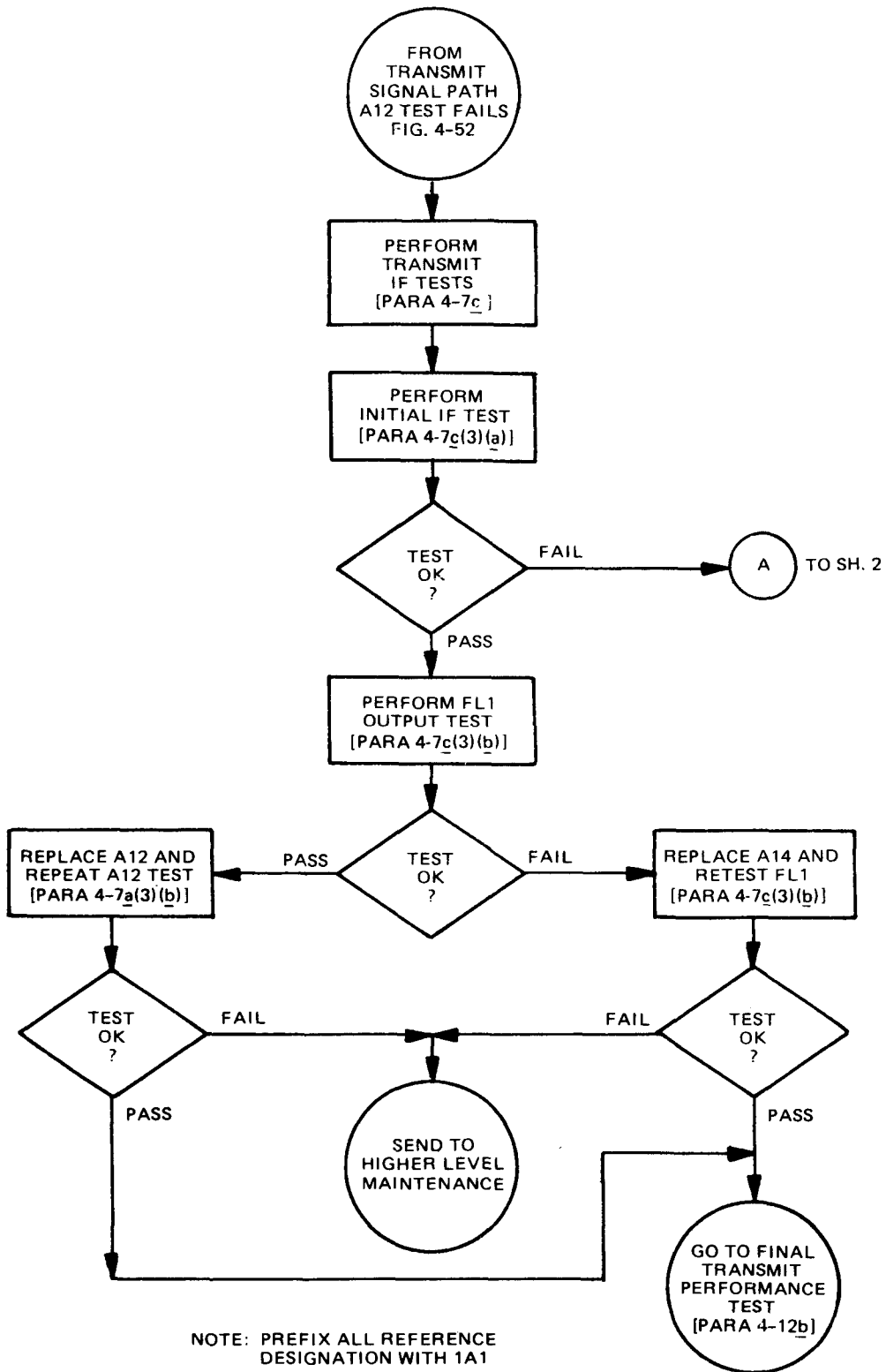

Figure 4-63. Transmit IF signal path test setup.

EI.5WS104



NOTE: PREFIX ALL REFERENCE DESIGNATION WITH 1A1

EL5WS105 (1)

Figure 4-64. Transmit IF signal path troubleshooting diagram (sheet 1 of 2).

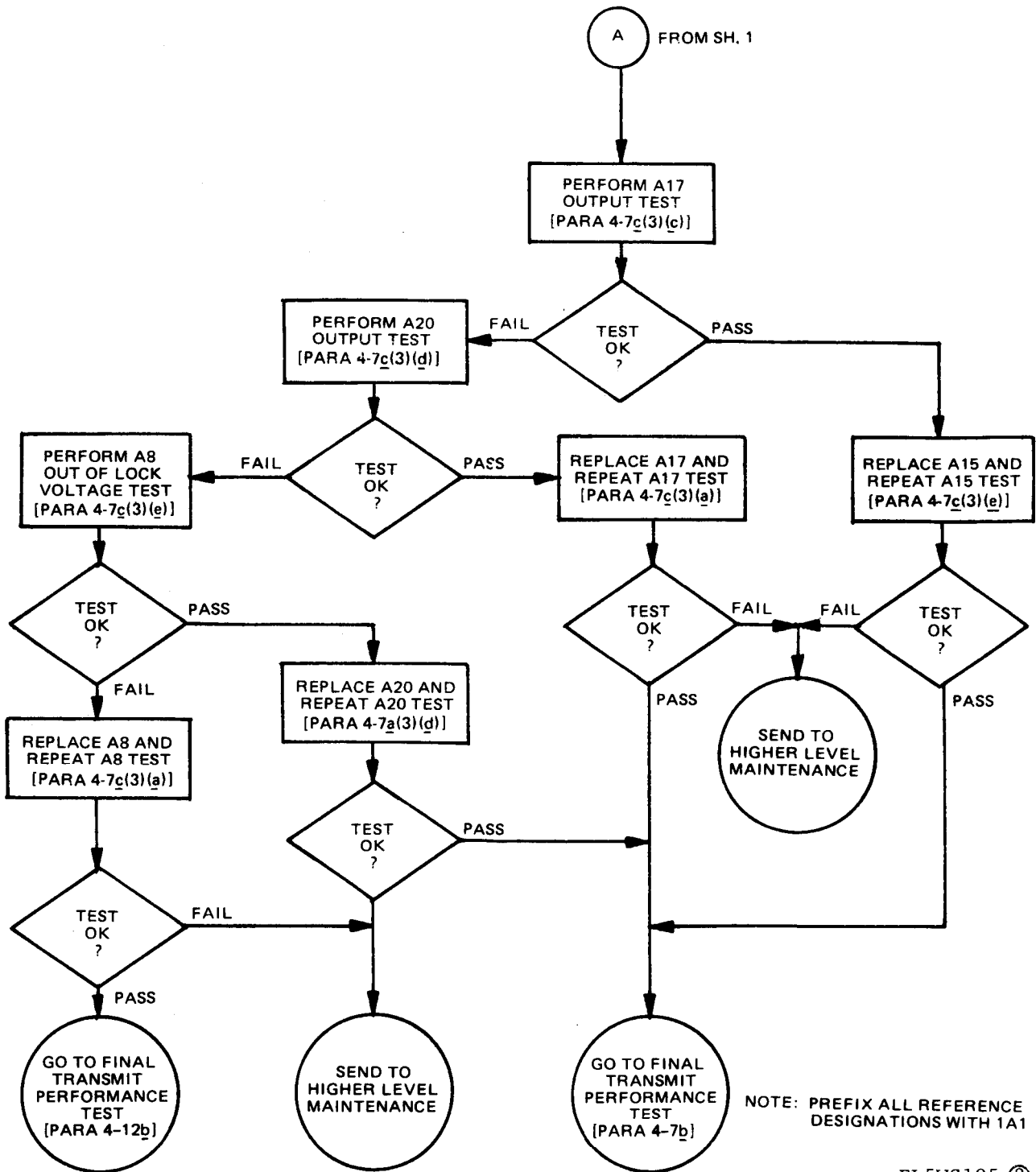
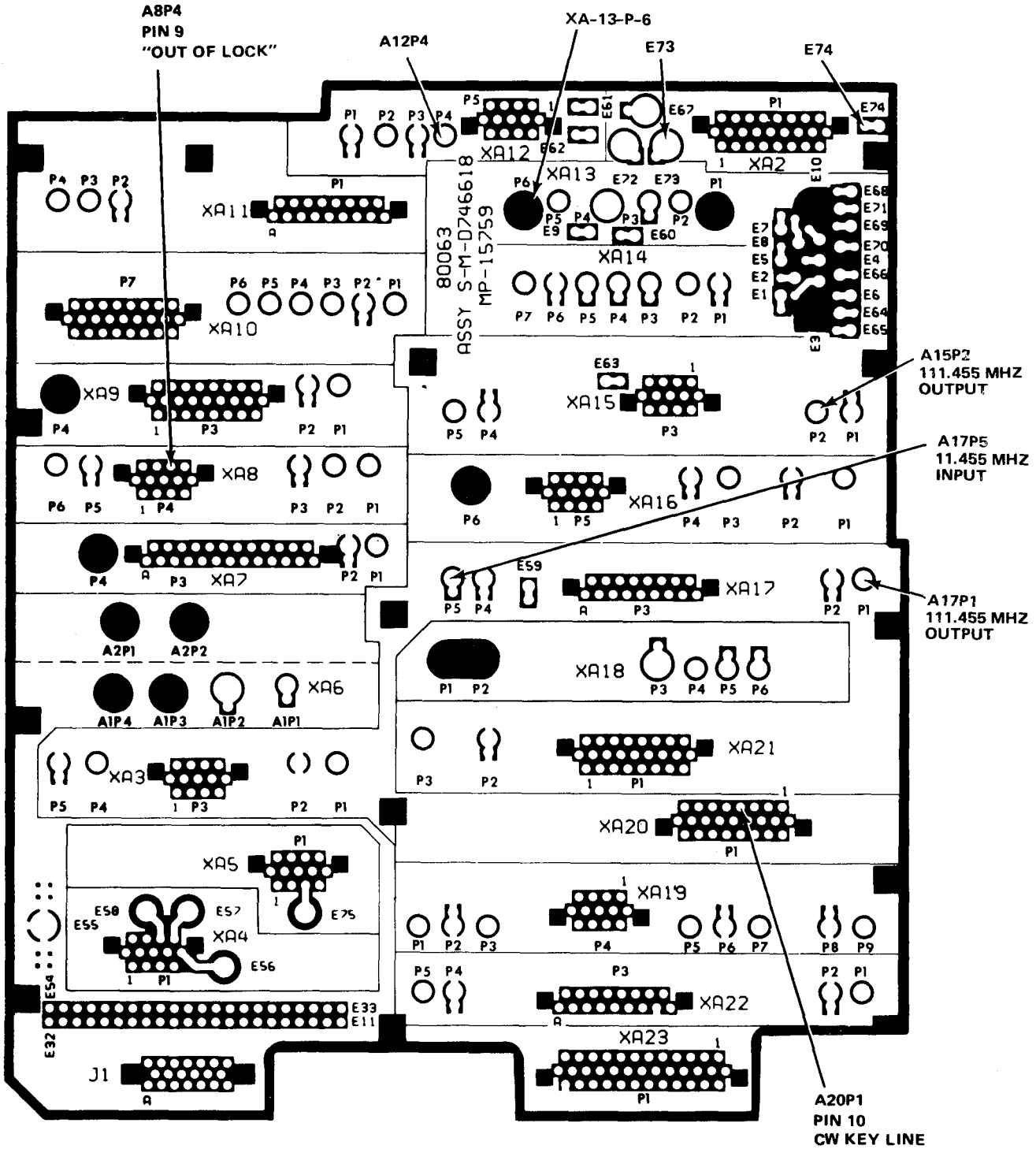

Figure 4-64. Transmit IF signal path troubleshooting diagram (sheet 2 of 2).



NOTE: PREFIX ALL REFERENCE DESIGNATIONS WITH 1A1A31.

EL5WS106 ①

Figure 4-65. Transmit IF signal path test point locations (sheet 1 of 2).

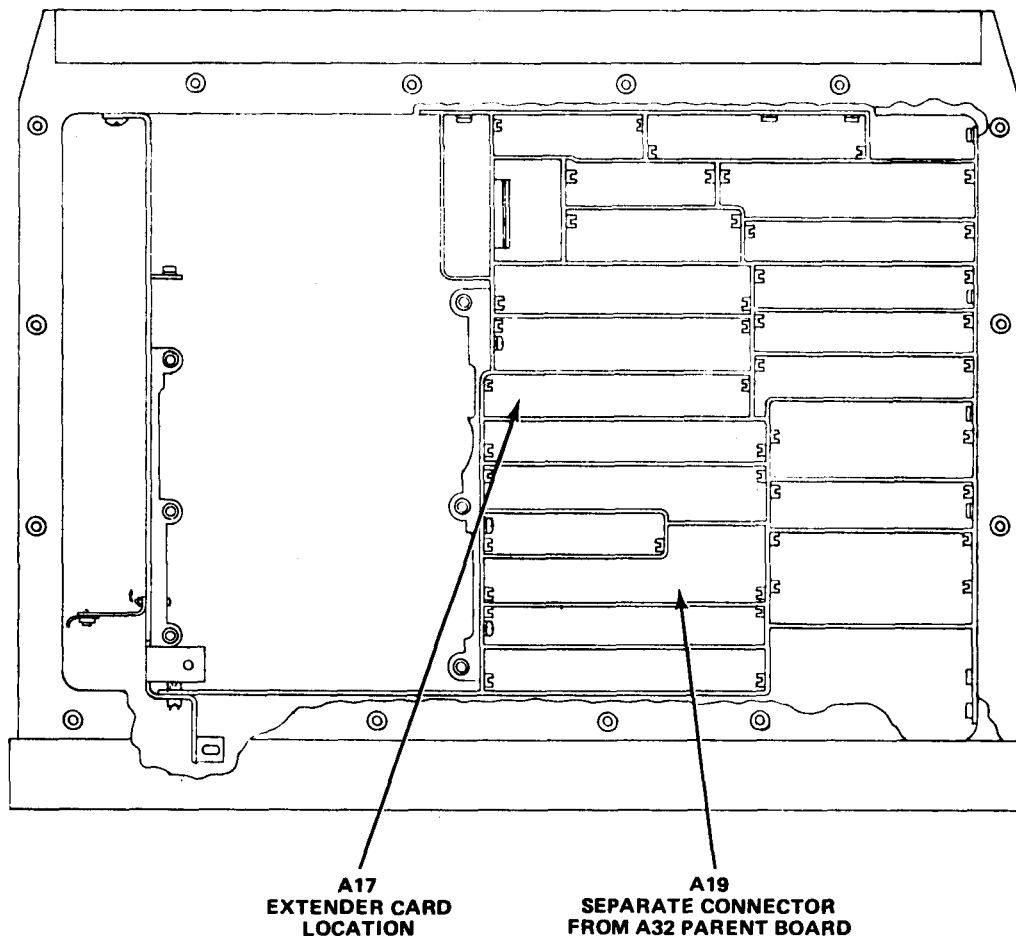

EL5WS106 ②

Figure 4-65. Transmit IF signal path test point locations
(sheet 2 of 2).

Check to see that output at XA8, pin 9, is $+5 \pm 1$ V dc on multimeter after 3 second delay (see fig. 4-62).

(d) Second IF 1A1A17 output test.

1. Set Step Attenuator to 50 dB.
2. Using a standard BNC cable, connect Oscilloscope to A17 Extender Card, P1 (see fig. 4-66).
3. Check to see that output level is more than 100 mV p-p.

(e) Filter Assembly 1A1AFL1 output test.

1. Set step attenuator to 45 dB.
2. Check the output FL1-J2 for a signal level greater than 80 mV p-p (see fig. 4-67). Ensure that oscilloscope is terminated into 50 ohm load.

d. Transmit Audio Signal Path (fig. 4-69).

(1) Transmit audio signal path test setup.

- (a) Equipment setup.* Setup equipment as shown in figure 4-69.
- (b) RT and equipment control settings.*

1. RT control settings:

POWER - LO PWR
MODE - SSB
FREQUENCY - 2.1500 MHz

2. Equipment control settings:

Adjust POWER SUPPLY to $+24 \pm 0.5$ V

dc.

Set Audio Oscillator No. 1 to 1500 Hz.
Adjust level to 2.0 mV out of Isolation Box.

Set audio Oscillator No. 2 to 2800 Hz.
Adjust level to 2.0 mV out of Isolation Box.

(2) Audio modulation signal path test.

(a) Modulator/Squelch A21 output test.

1. Connect Oscilloscope to XA21P3 (see fig. 4-70).
2. Disconnect Audio Oscillator No. 2.
3. Key the RT.
4. Check to see that the 455 kHz upper and lower sideband, peak to rms output level at XA21P3, is between 250 and 500 mV p-p.

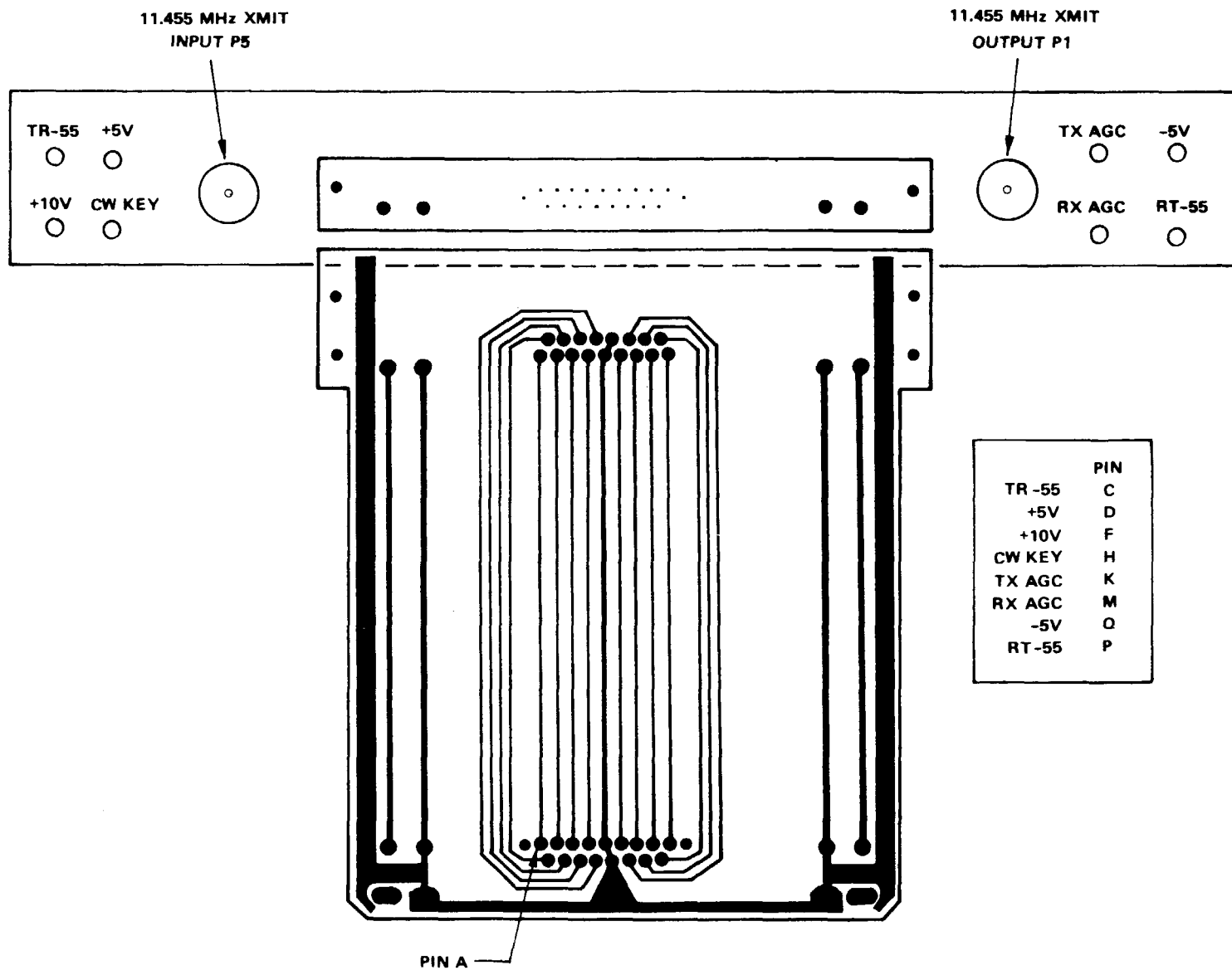

Figure 4-66. A17 extender card.

EL5WS096

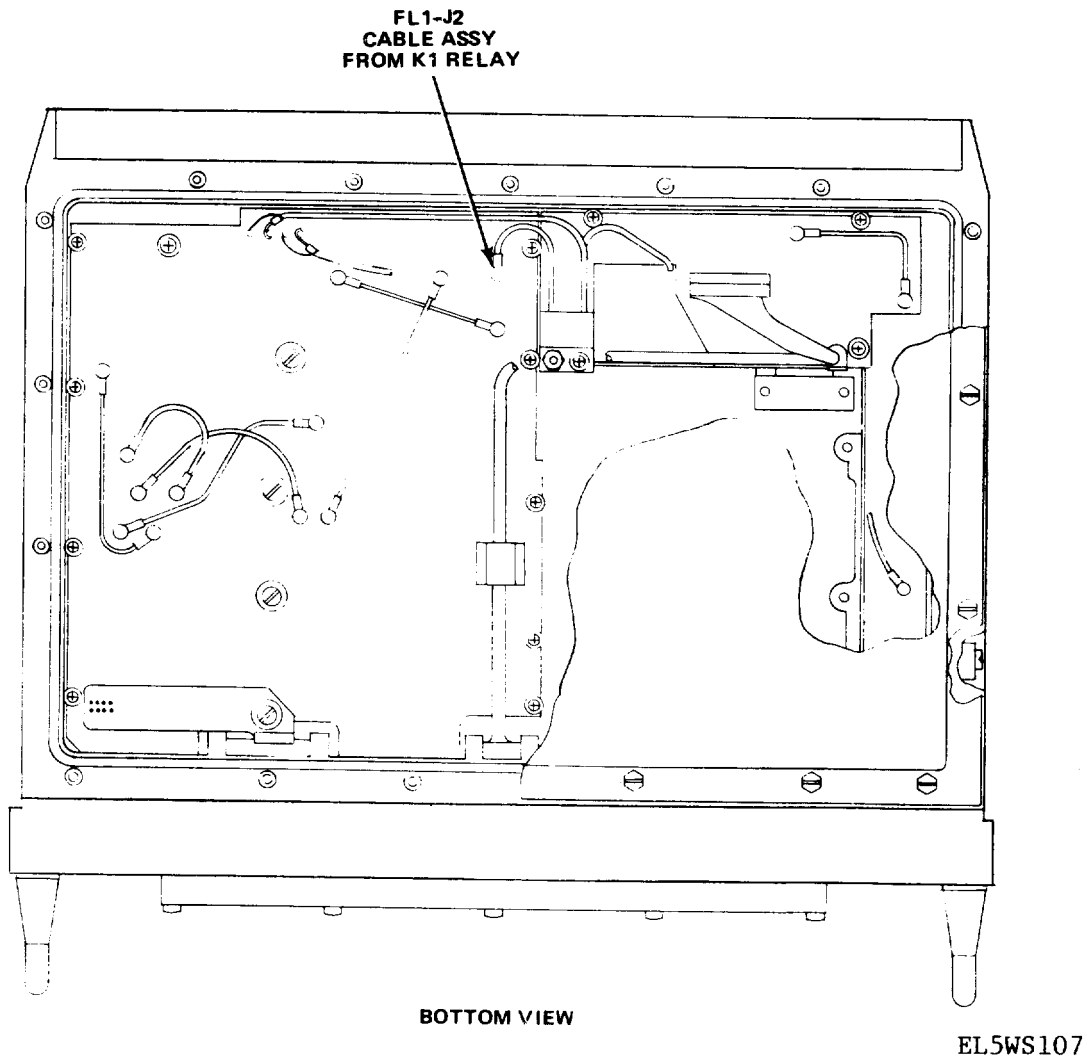
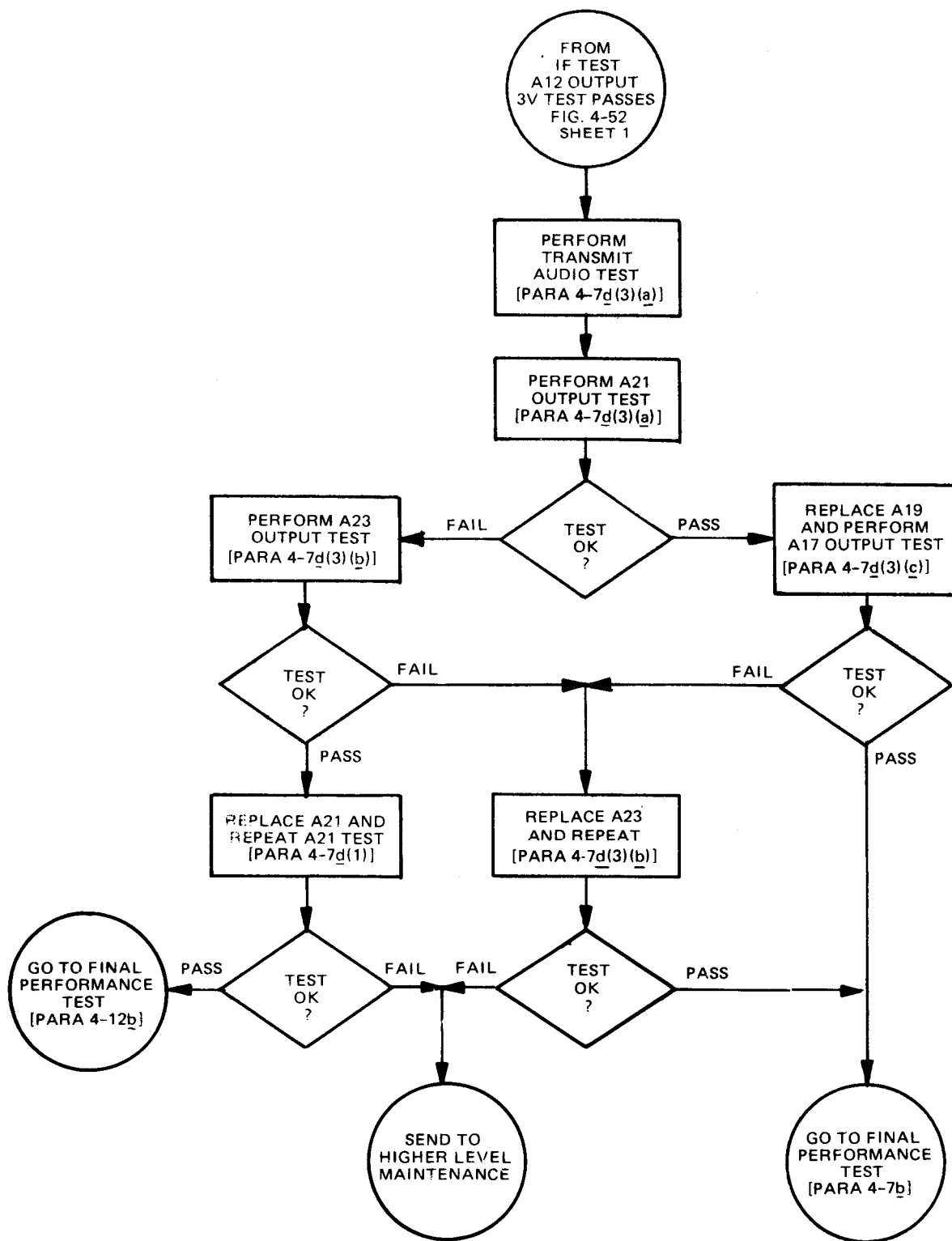

Figure 4-67. Transmit IF signal path cable location guide.



NOTE: PREFIX ALL REFERENCE DESIGNATIONS WITH 'A1.'

Figure 4-62. Transmit audio signal path troubleshooting diagram.

EL5WS108

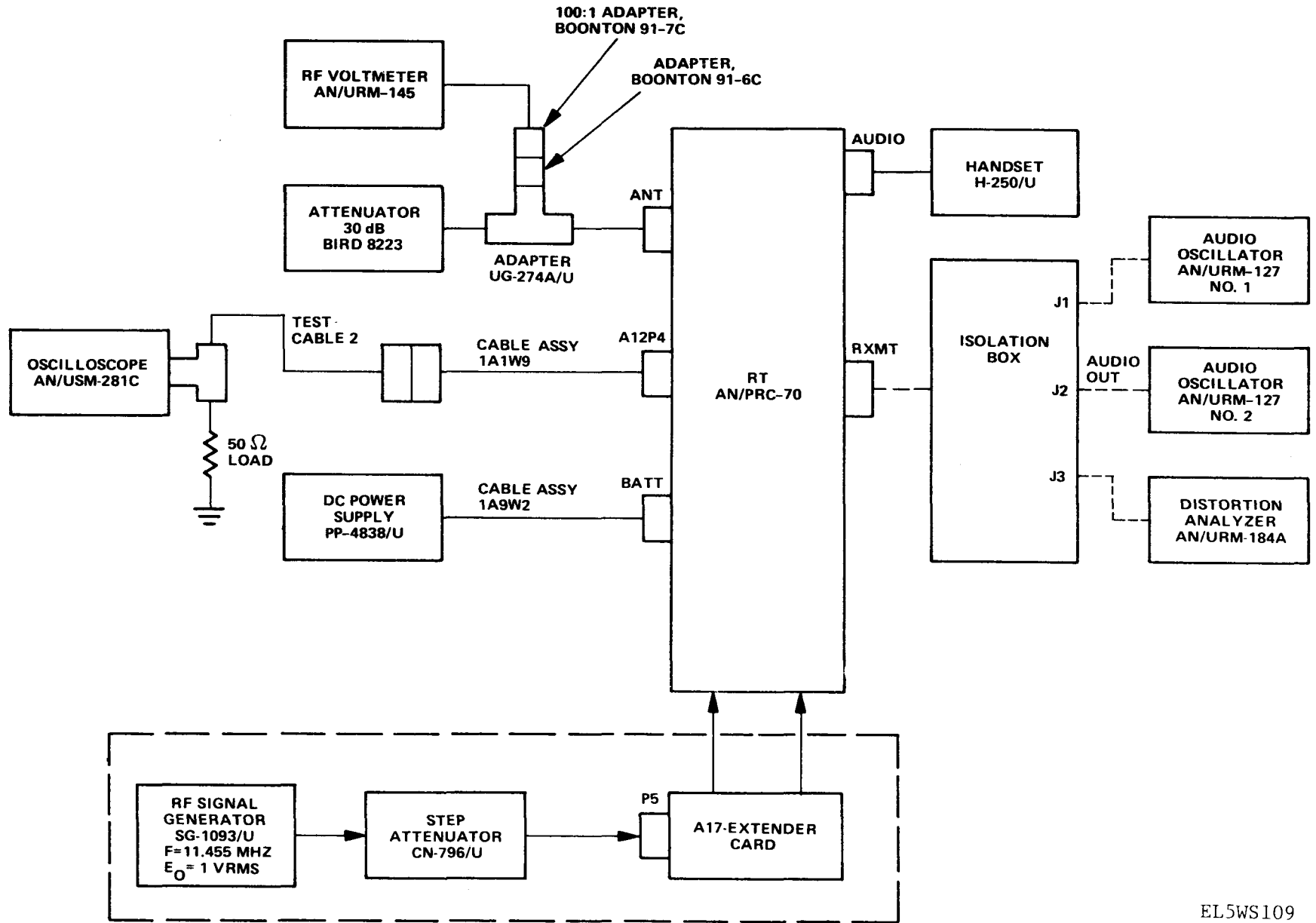
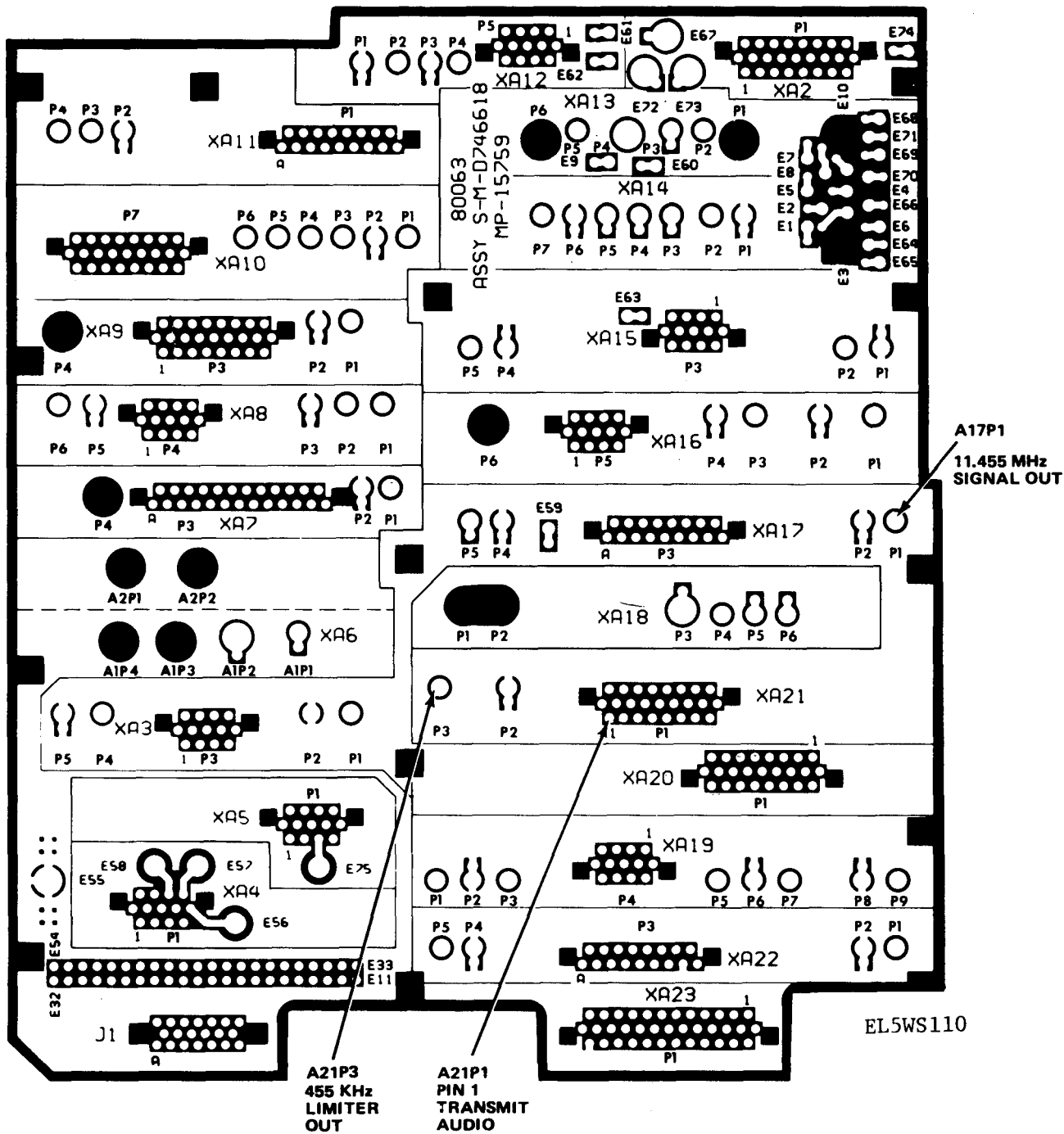

Figure 4-69. Transmit audio signal path test setup.



NOTE: PREFIX ALL REFERENCE DESIGNATIONS WITH 1A1A31.

Figure 4-70. Transmit audio signal path test point locations.

5. Unkey the RT.

(b) *Audio A23 output test.*

1. Key the RT.

2. Check to see that voltage at XA21P1, pin 1, is more than 1.8 V p-p.

3. Unkey the RT.

(c) *Second IF A17 output test.*

1. Reconnect Audio Oscillator No. 2. Connect Oscilloscope to A17P1 on extender Card (fig. 4-71), or A31 Motherboard (fig. 4-70).

2. Key the RT.

3. Check to see that voltage level is more than 0.8 V p-p.

4. Unkey the RT.

e. *No-Tune Tone Tests* (fig. 4-72).

(1) *No-tune tone test setup.*

(a) *Equipment setup.*

1. Setup equipment as shown in figure 4-73.

(2) *RT and equipment control settings.*

(a) *RT control settings.*

1. POWER - LO PWR

2. MODE - AM

3. FREQUENCY - 2.1500 MHz

(b) *Equipment control settings.*

1. Adjust POWER SUPPLY for 24 \pm 0.5 V dc.

(3) *No-Tune tone troubleshooting tests.*

(a) *A11 output, no-tune test.*

1. Connect 30 dB attenuator to ANT connector.

2. Key the RT.

3. Using Oscilloscope, check to see that no. 2 kHz signal level less than 100 mV is present at A11TP5, see figure 4-74, sheet 1. Do *not* unkey RT.

4. At the same test point, check the burst waveform by removing the 50-ohm load from the ANT terminal. See figure 4-74, sheet 1, indicating test limits for the burst waveshape.

5. Unkey the RT.

(b) *A11 No-Tune "CONTROL LINE".*

1. Connect 50-ohm Attenuator to RT.

2. Key the RT.

3. Check to see that the "No-Tune Tone" control voltage at A31E68 is less than 0.3 V dc, see figure 4-74. Do *not* unkey RT.

4. Disconnect Attenuator from RT, and check to see that voltage at A31E68 is more than 6.0 V dc.

5. Unkey the RT.

(c) *A27, VSWR detector.*

1. Connect 30 dB Attenuator to RT.

2. Key the RT.

3. Check to see that voltage at A32WT12 is less than 0.5 V dc (indicates a low VSWR), see figure 4-74. Unkey RT.

4. Disconnect the 30 dB Attenuator from the RT. Key RT and check to see that voltage at A32WT12 is more than 6.0 V dc (indicates a high VSWR). Unkey RT.

f. *Sidetone Tests* (see fig. 4-75, sheets 1 and 2).

(1) *Sidetone test setup.* Setup equipment as shown in figure 4-76.

(2) *RT and equipment control settings.*

(a) *RT control settings.*

1. POWER - LO PWR

2. MODE - SSB

3. FREQUENCY - 2.1500 MHz

4. SQUELCH - OFF

5. VOLUME - MIDRANGE

(b) *Equipment control settings.*

1. Adjust audio oscillator No. 1 to 2000 Hz and measure output level of 2.0 mV ac at J3 of Isolation Box (audio oscillator No. 2 disconnected) then reconnect audio oscillator No. 1 to J1.

(3) *Sidetone tests.*

(a) *Sidetone control at rated output power.*

1. Key the RT.

2. Check to see that voltage level at A31E64 is less than -1.0 V dc, see figure 4-77.

3. Unkey the RT.

(b) *Presence of sidetone at rated output power.*

1. Key the RT.

2. A sidetone should be heard.

3. Unkey the RT.

(c) *Sidetone control at low output power.*

1. Set Audio Oscillator No. 1 to 5000 Hz.

2. Key the RT.

3. Check to see that voltage level at A31E64 is greater than 6.0 V dc.

4. Unkey the RT.

(d) *Absence of sidetone at low output power.*

1. Key the RT.

2. No sidetone should be heard.

3. Unkey the RT.

g. *NB FM Transmit Audio Tests* (fig. 4-78, sheets 1 and 2).

(1) NB FM transmit audio test setup. Setup equipment as shown in figure 4-79.

(2) *RT and equipment control settings.*

(a) *RT control settings.*

1. POWER - LO PWR

2. MODE - FM

3. FREQUENCY - 35.055 MHz

4. SQUELCH - OFF

(b) *Equipment control settings.*

1. Power Supply to +24 \pm 0.5 V dc output.

2. Audio Oscillators No. 1 and No. 2 are disconnected.

(3) *NB FM modulation tests.*

(a) *Oscillator Distributor A10 output test.*

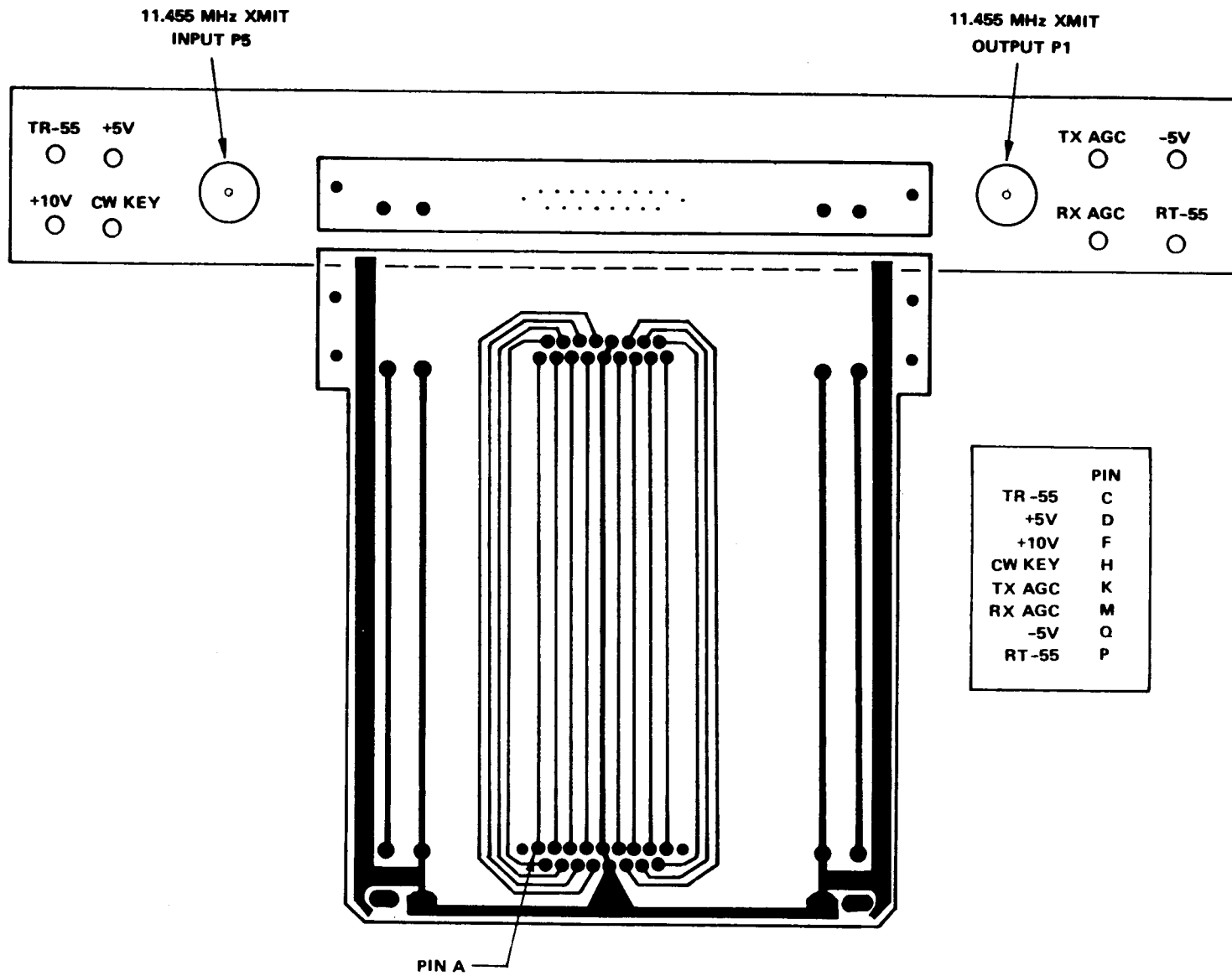
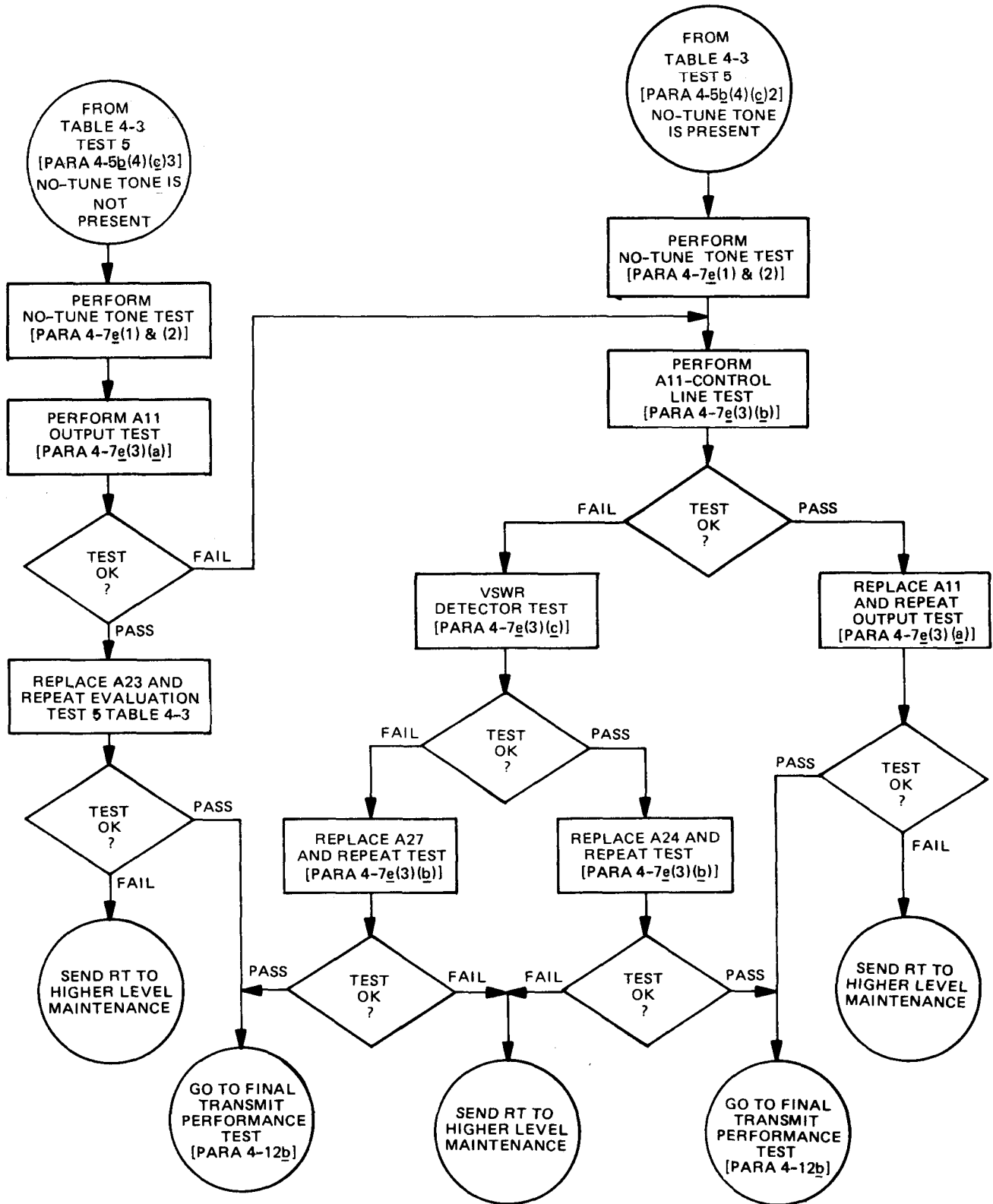

Figure 4-71. A17 extender card.

EL5WS096



NOTE: PREFIX ALL REFERENCE DESIGNATIONS WITH 1A1

EL5WS111

Figure 4-72. No-Tune tone troubleshooting diagram.

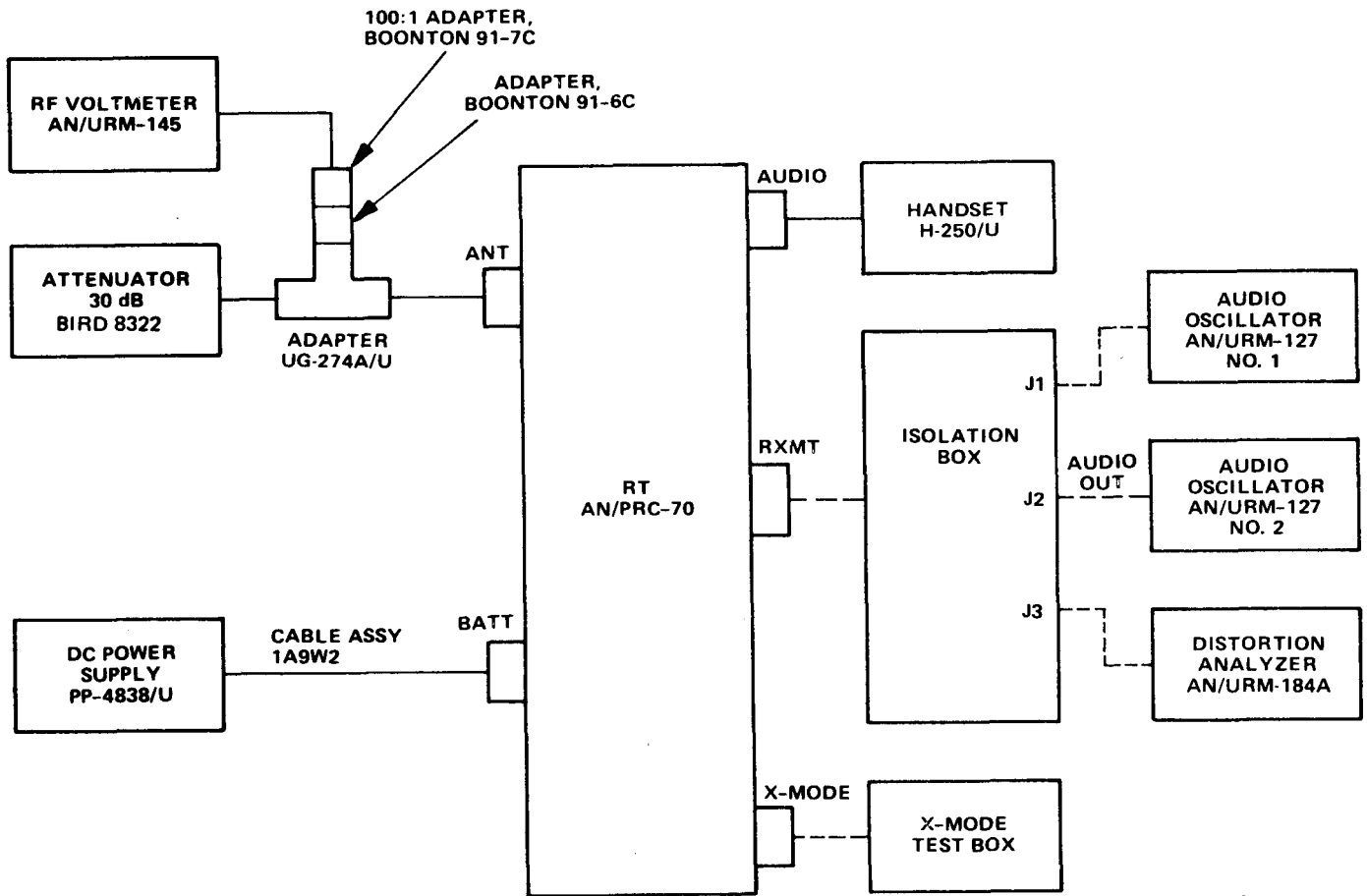

EL5WS112

Figure 4-73. No-Tune tone transmit test setup.

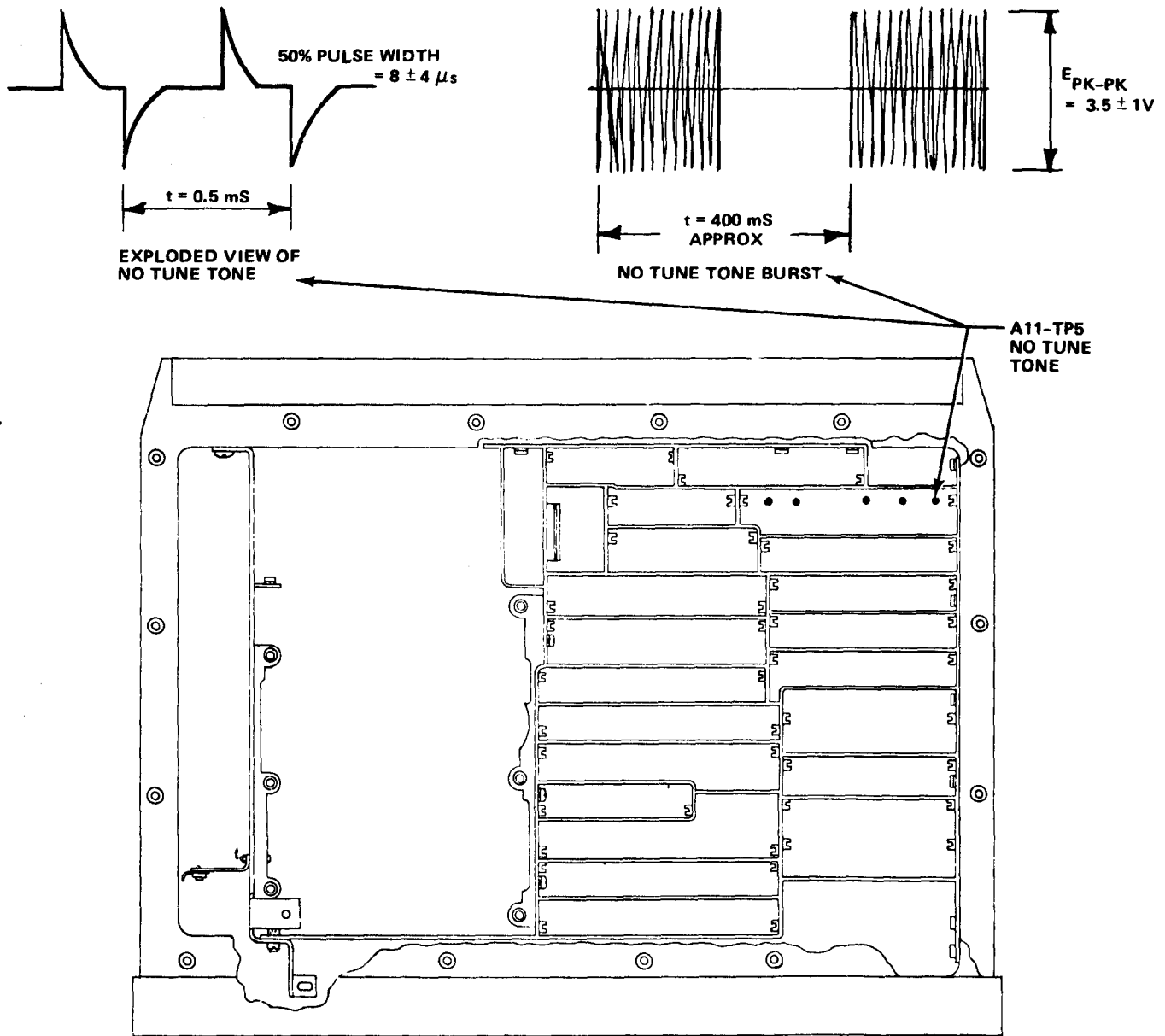

EL5WS113 ①

Figure 4-74. No-Tune test point locations (sheet 1 of 3).

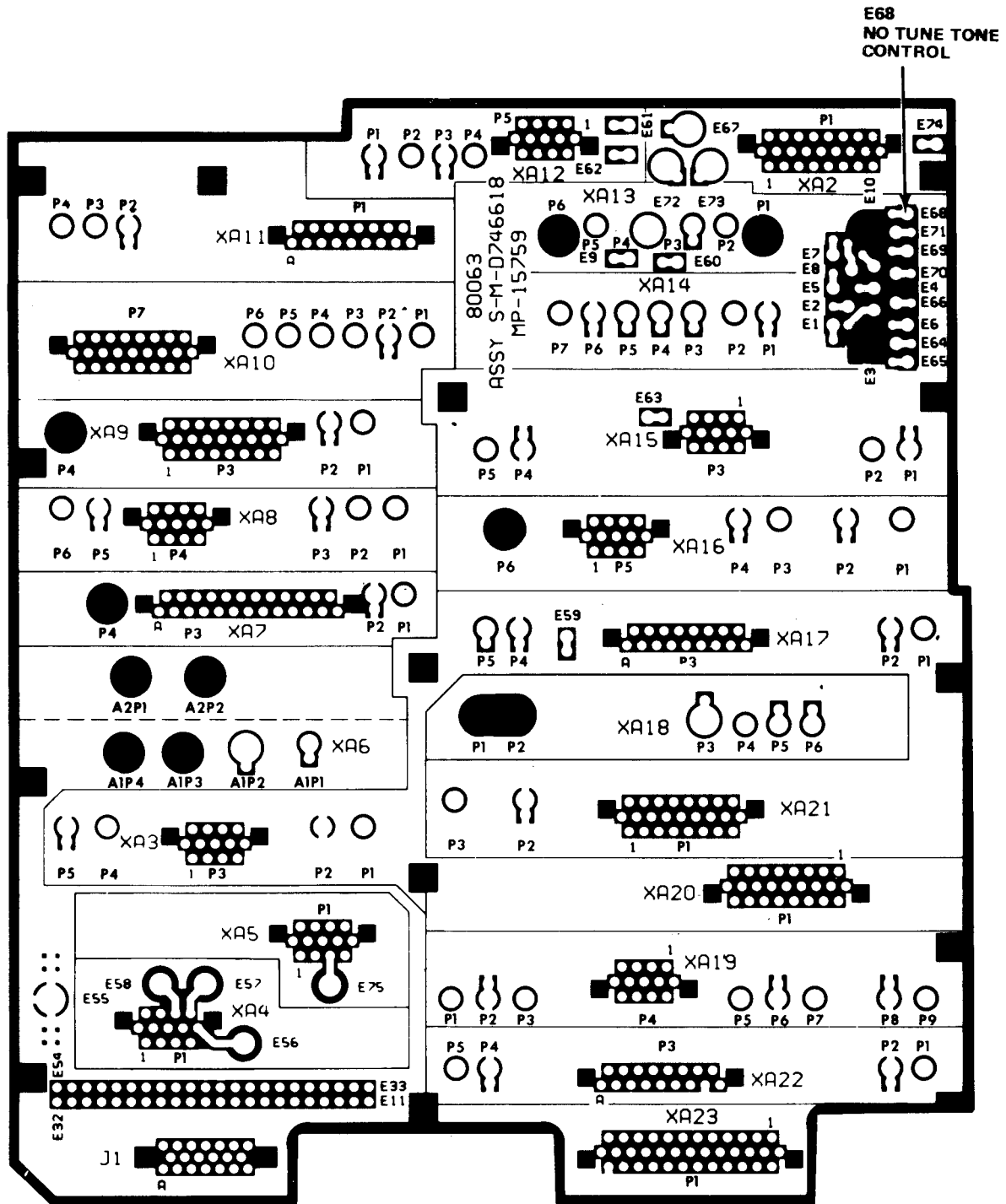

EL5WS113 ②

NOTE: PREFIX ALL REFERENCE DESIGNATIONS WITH 1A1.

Figure 4-74. No-Tune test point locations (sheet 2 of 3).

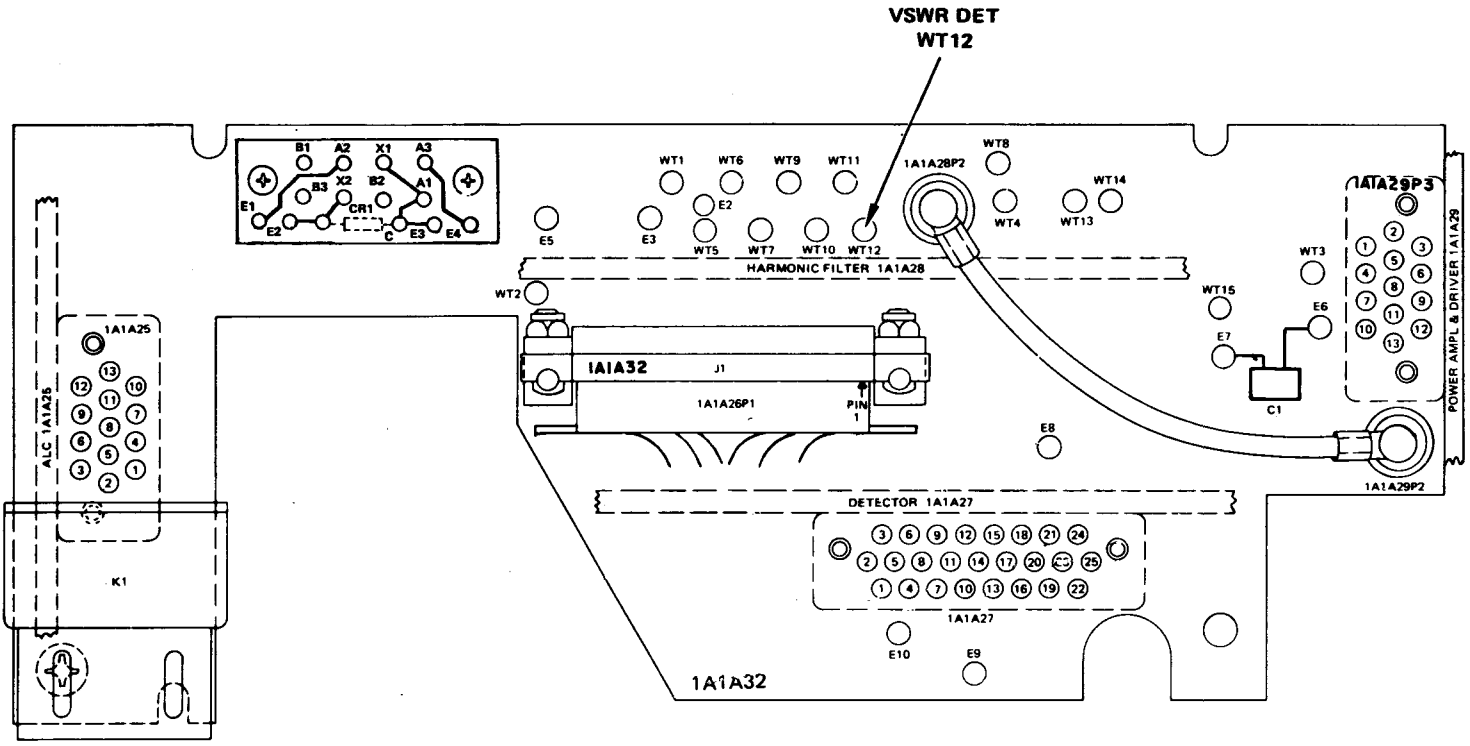

EL5WS113 ③

Figure 4-74. No-Tune test point locations (sheet 3 of 3).

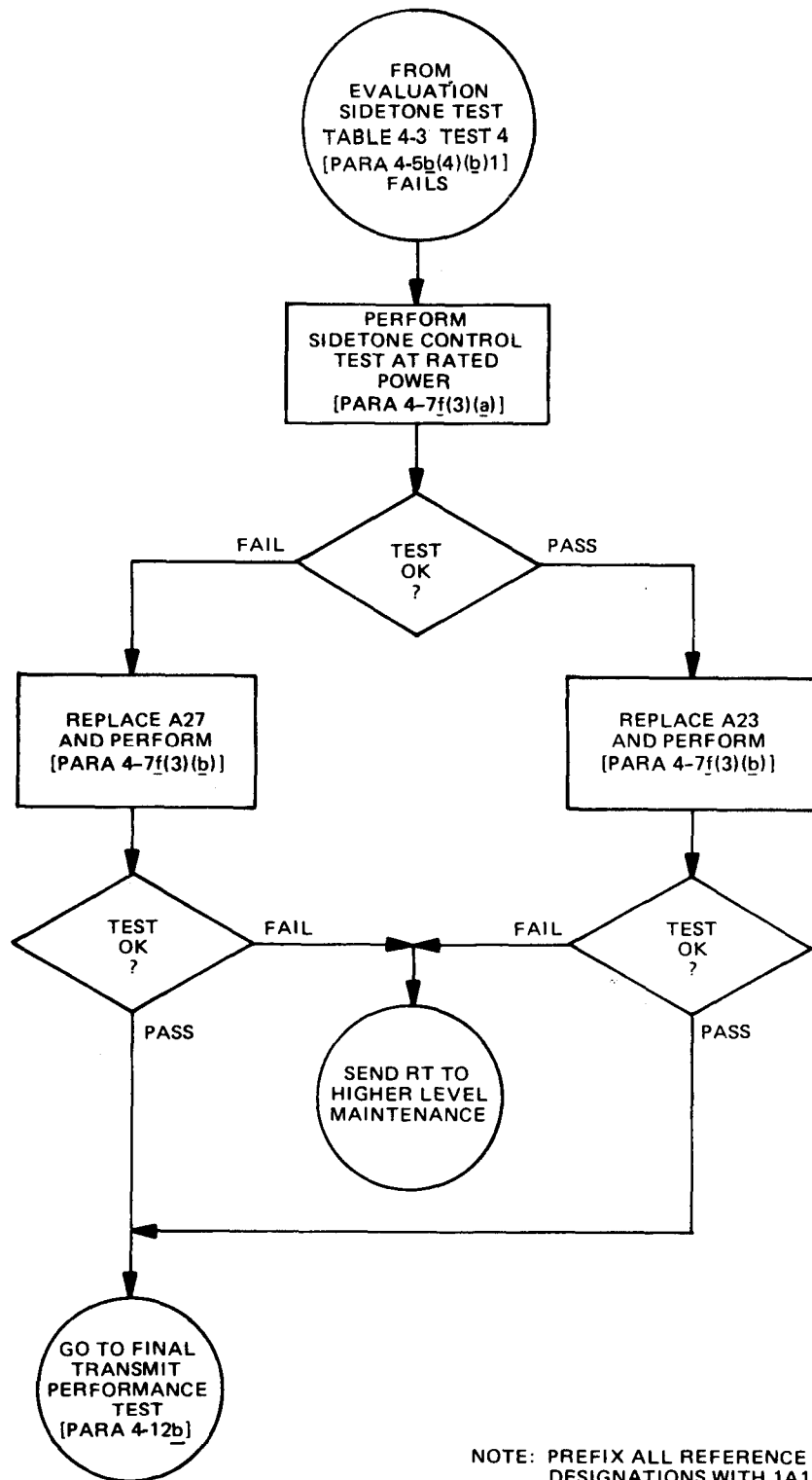

NOTE: PREFIX ALL REFERENCE DESIGNATIONS WITH 1A1.

EL5WS114 ①

Figure 4-75. Sidetone test flow diagram (sheet 1 of 2).

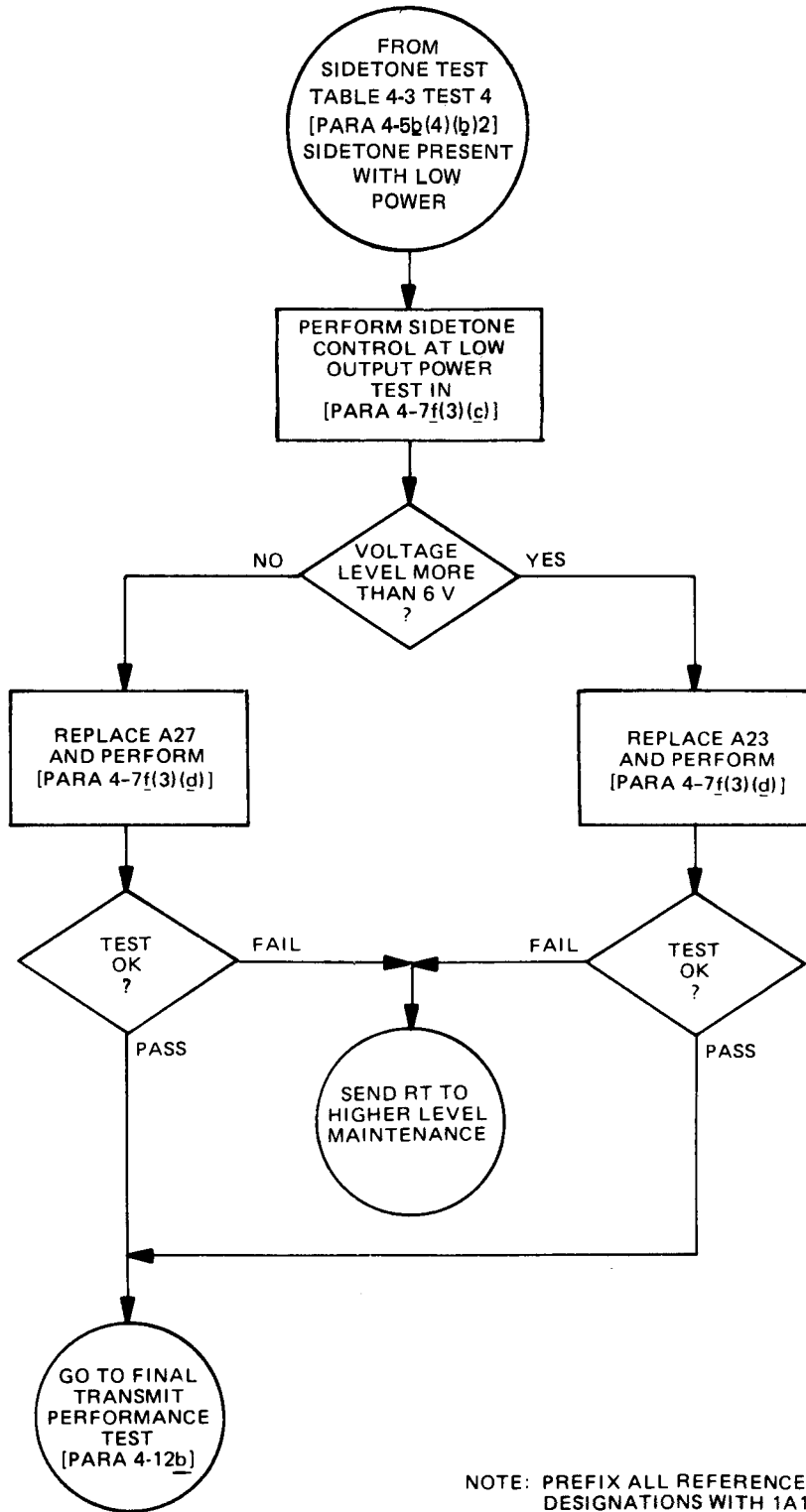

NOTE: PREFIX ALL REFERENCE DESIGNATIONS WITH 1A1.

EL5WS114 ②

Figure 4-75. Sidetone test flow diagram (sheet 2 of 2).

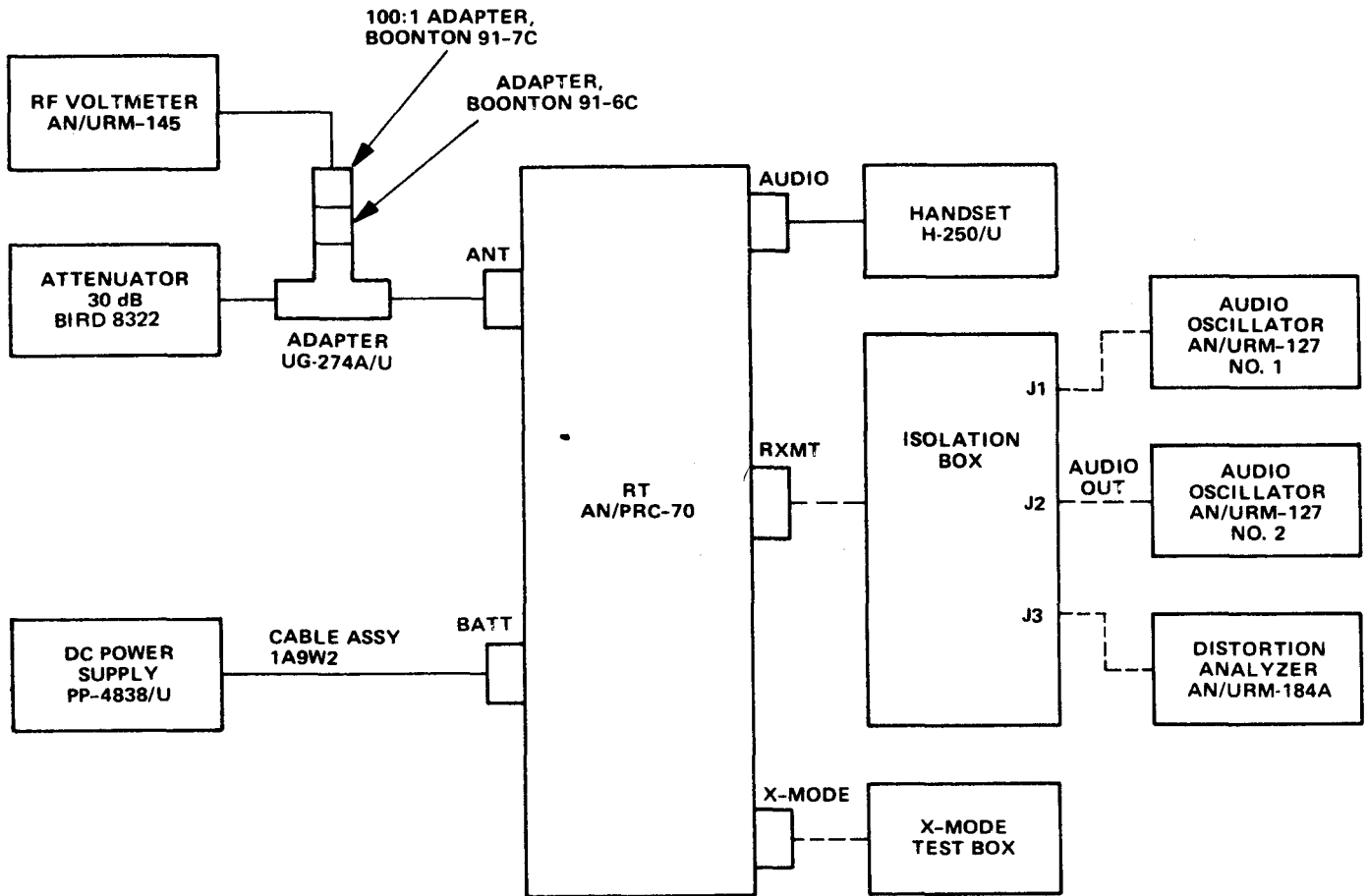

EL5WS115

Figure 4-76. Sidetone test setup.

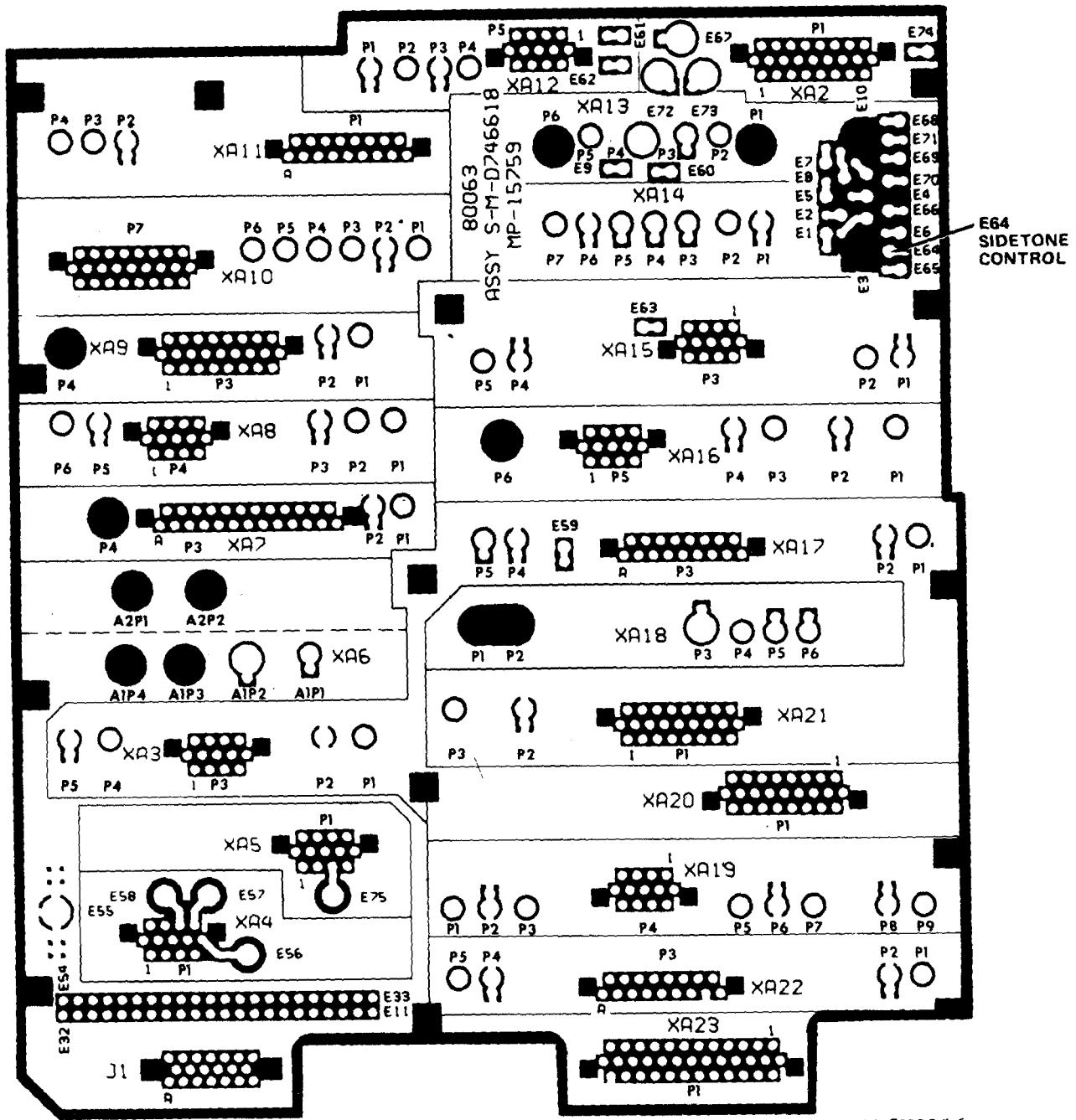
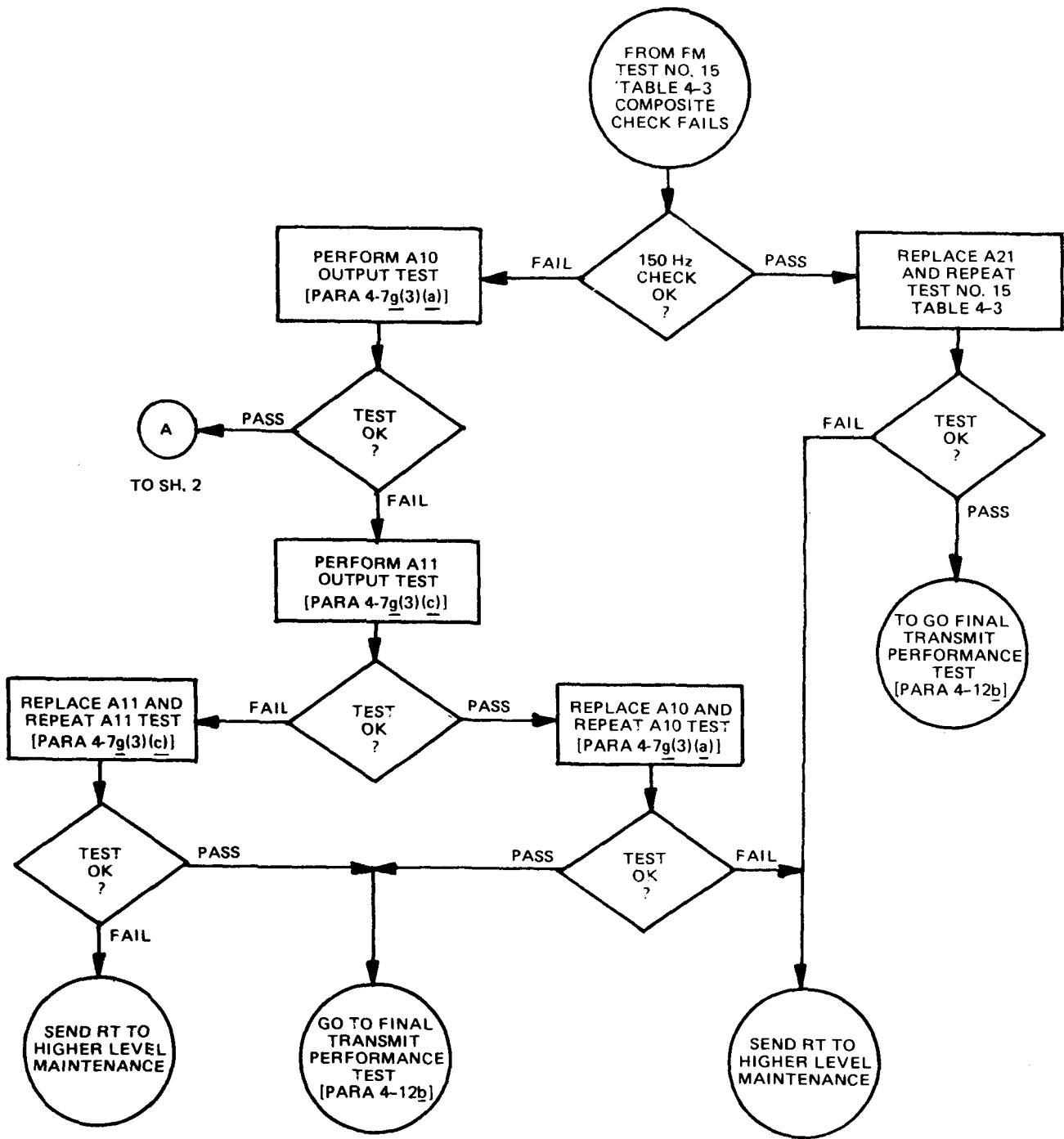

Figure 4-77. Sidetone test point location.



NOTE: PREFIX ALL REFERENCE DESIGNATIONS WITH 1A1

EL5WS117 ①

Figure 4-78. NB FM transmit audio flow diagram (sheet 1 of 2).

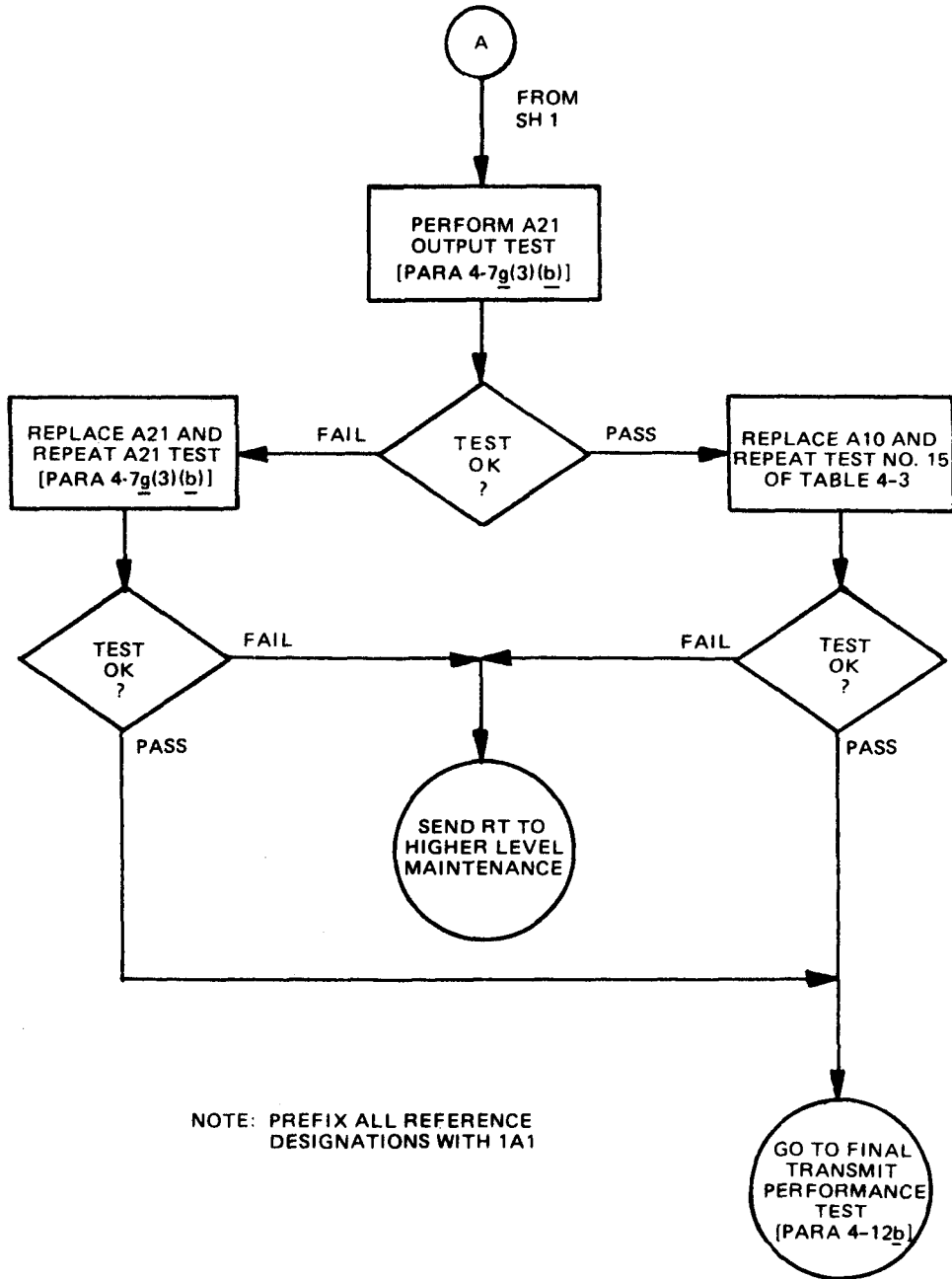

EL5WS117 (2)

Figure 4-78. NB FM transmit audio flow diagram (sheet 2 of 2).

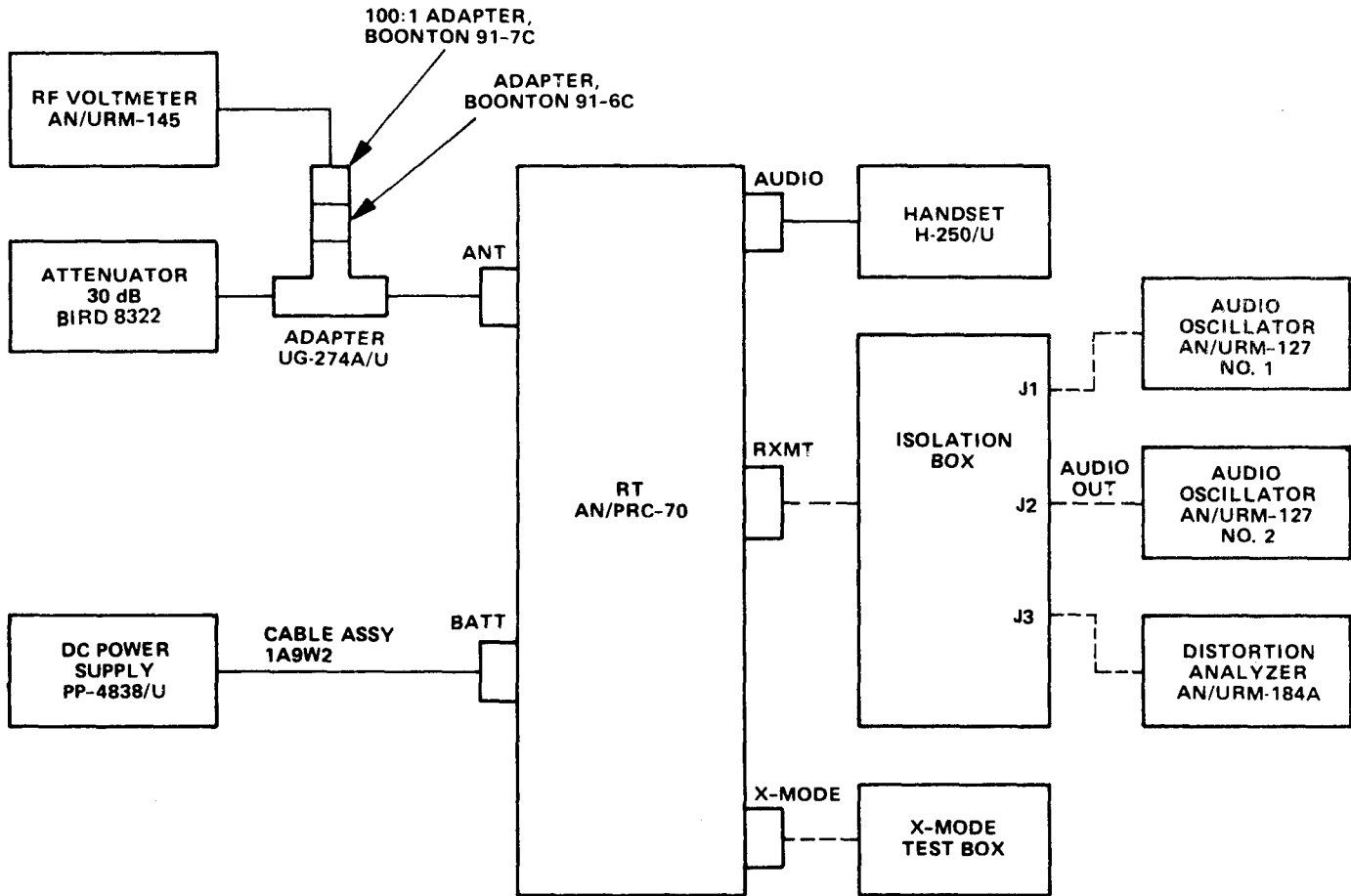

EL5WS120

Figure 4-79. NB FM transmit audio test setup.

1. Connect Oscilloscope to A10 TP3 (fig. 4-80, sheet 2).

2. Check to see that the 150 Hz frequency at A19TP3 is 1.0 ± 0.2 V p-p in amplitude.

(b) Modulator/Squelch A21 output test.

1. Insure two audio signals at input to RT are disconnected.

2. Key RT.

3. Using multimeter, measure FM gate control level at A21P1-PIN 9, see fig. 4-80 (sheet 1). Level should be greater than 9.0 V dc.

4. Using oscilloscope, measure audio level (150 Hz) at A21P1-PIN 12 (fig. 4-80, sheet 1). Audio level should be 0.6 ± 0.2 V p-p.

5. Unkey RT.

(c) Digital Divider All output test.

1. Connect Oscilloscope to A 11TP4 (fig. 4-80, sheet 2).

2. Check to see that waveform at A11TP4 has a frequency of 150 ± 2 Hz and is more than 9.0 V p-p.

k. Transmit CW/FSK Troubleshooting Test (see fig. 4-81). CW/FSK troubleshooting test is performed when either transmit evaluation test No. 6 or FSK test No. 7 of table 4-3 fails.

(1) Initial CW/FSK test setup.

(a) Equipment setup.

1. Setup equipment as shown in figure 4-82.

(2) RT and equipment control settings.

(a) RT control settings.

1. POWER - LO PWR

2. MODE - CW

3. FREQUENCY - 2.1500 MHZ

(b) Equipment control settings. Adjust power supply to +24 +0.5 V dc output with current limited to 10.0 amperes.

(3) Transmit CW/FSK tests.

(a) All test.

1. Use oscilloscope to monitor voltage waveforms at A11TP2 (fig. 4-83, sheet 1). Ensure oscilloscope vertical amplifier is set at DC.

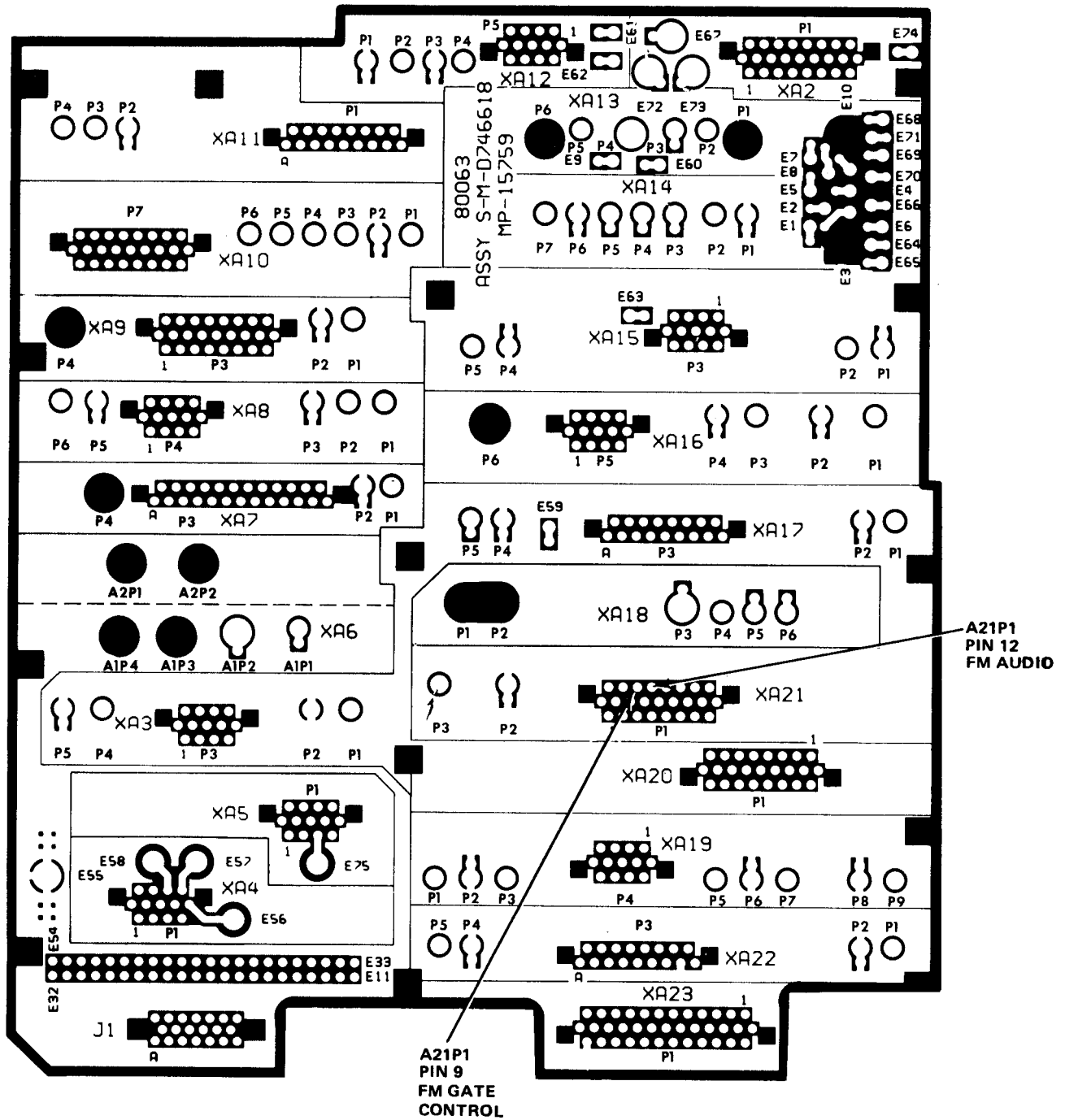

NOTE: PREFIX ALL REFERENCE DESIGNATIONS WITH 1A1A31

EL5WS121 ①

Figure 4-80. NB FM transmit audio test point location
(sheet 1 of 2).

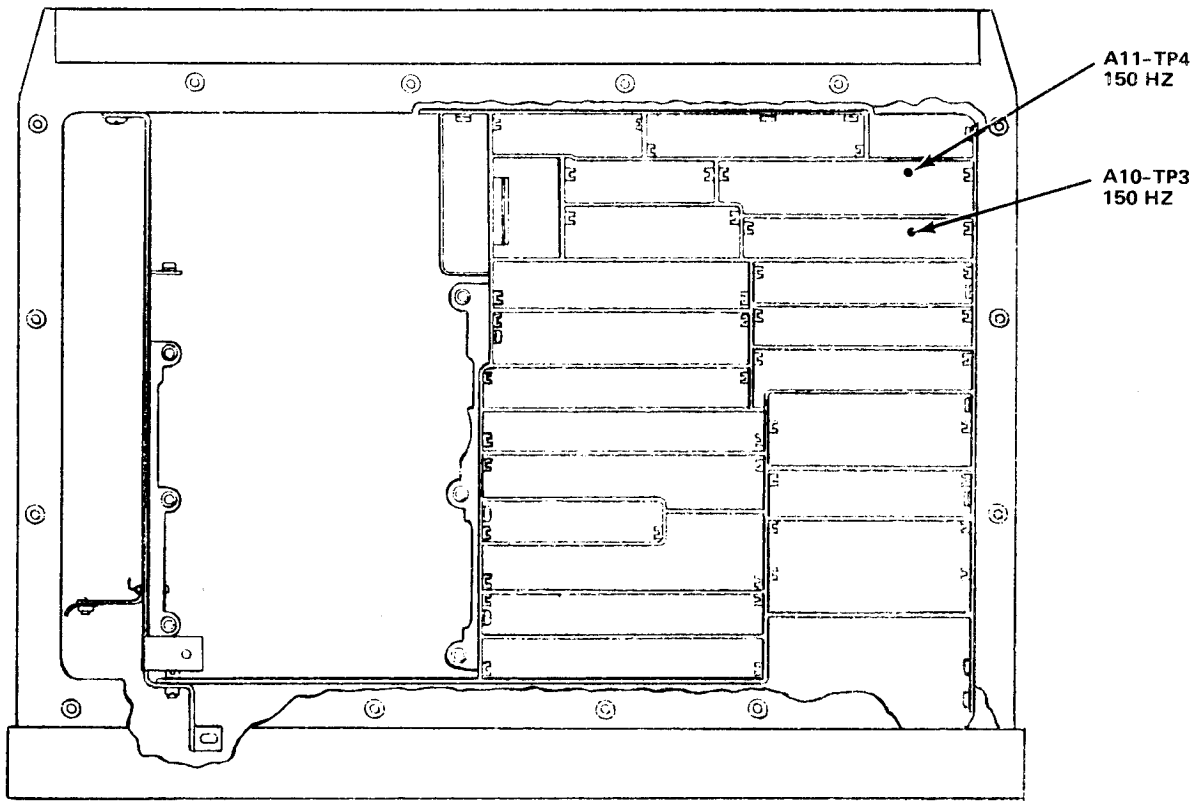

TOP VIEW

NOTE: ONLY TEST POINTS (TP) USED IN ISOLATION TESTS ARE SHOWN.

EL5WS121 ②

Figure 4-80. NB FM transmit audio test point location (sheet 2 of 2).

2. Key the RT.

3. Check to see that waveform at A11TP2 is a squarewave; with an amplitude greater than 9.0 V p-p, and a frequency of 1580 Hz \pm 100 Hz. Set frequency counter channel A impedance switch to 1M.

4. Unkey the RT, and check to see that a 2430 Hz \pm 100 Hz signal remains about one second after unkeying RT. Check to see that level is more than 9.0 V ac p-p.

(b) A10 test.

1. Set RT MODE control to CW.

2. Key the RT.

3. Check to see that voltage at A19TP4 is more than 60 mV (fig. 4-83, sheet 2).

4. Unkey the RT.

(c) A20 test. Set RT MODE control to the mode given below. Using Oscilloscope, check voltage levels at the proper test point in the list. Key RT during each check then unkey.

Mode Test point Voltage level

CW A20TP1 Less than 0.5 V dc

FSK A20TP2 More than 9.0 V dc

Unkey) FSK A20TP2 More than 9.0 V dc
(should remain for about 1 second after unkeying)

FSK A20TP3 More than 9.0 V dc

Unkey) FSK A20TP3 Less than 0.3 V dc
(immediately after unkeying)

CW A20TP4 More than 9.0 V dc

i. Transmit Power Output Tests (fig. 4-84).

(1) Transmit power output test setup. Setup equipment as shown in figure 4-85.

(2) RT and equipment control settings.

(a) RT control settings.

1. POWER - HI POWER

2. MODE - SSB

3. FREQUENCY - failed frequency

(b) Equipment control settings.

1. Adjust power supply to +24 \pm 0.5 V dc output.

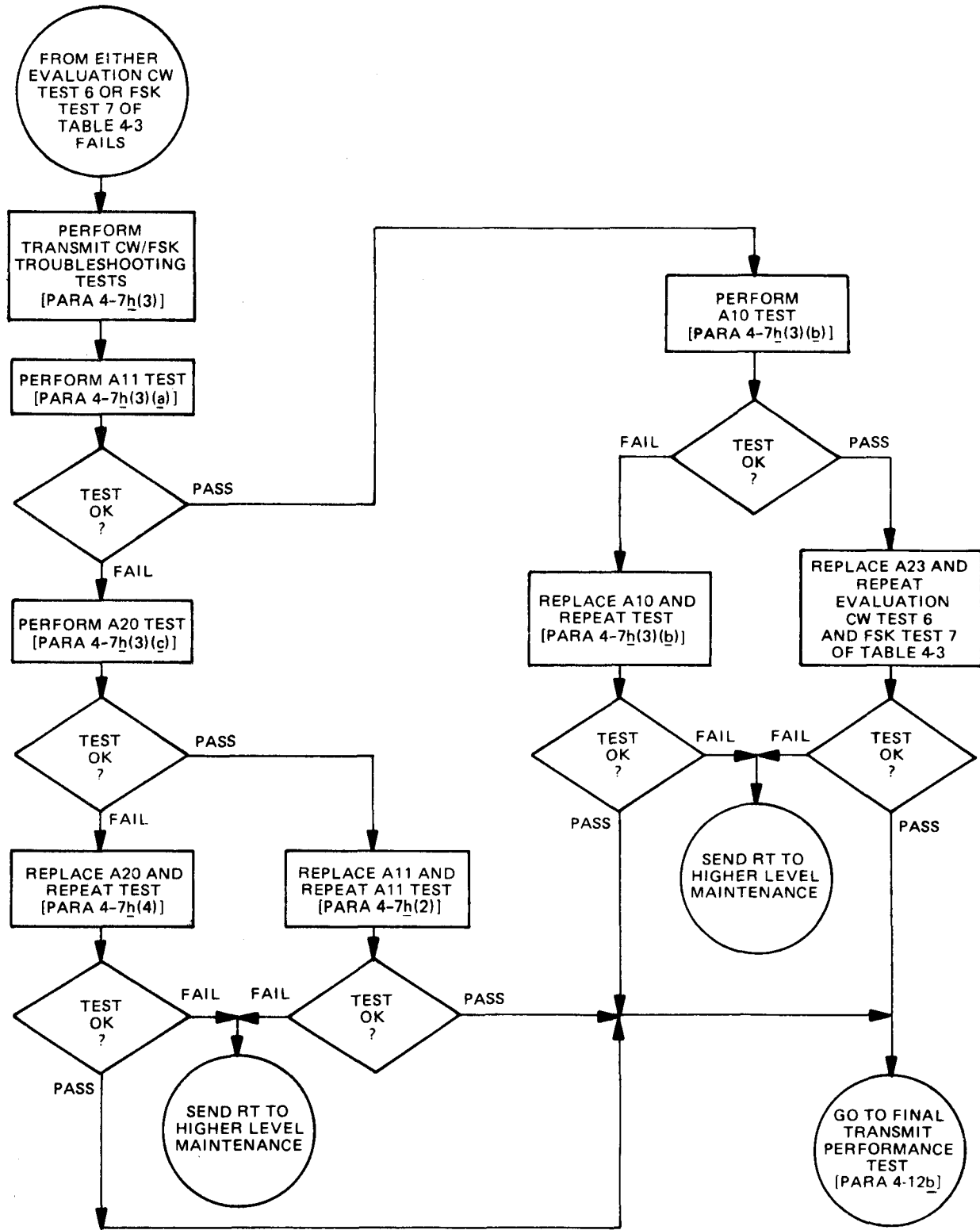

NOTE: PREFIX ALL REFERENCE DESIGNATIONS WITH 1A1.

EL5WS122

Figure 4-81. Transmit CW/FSK troubleshooting diagram.

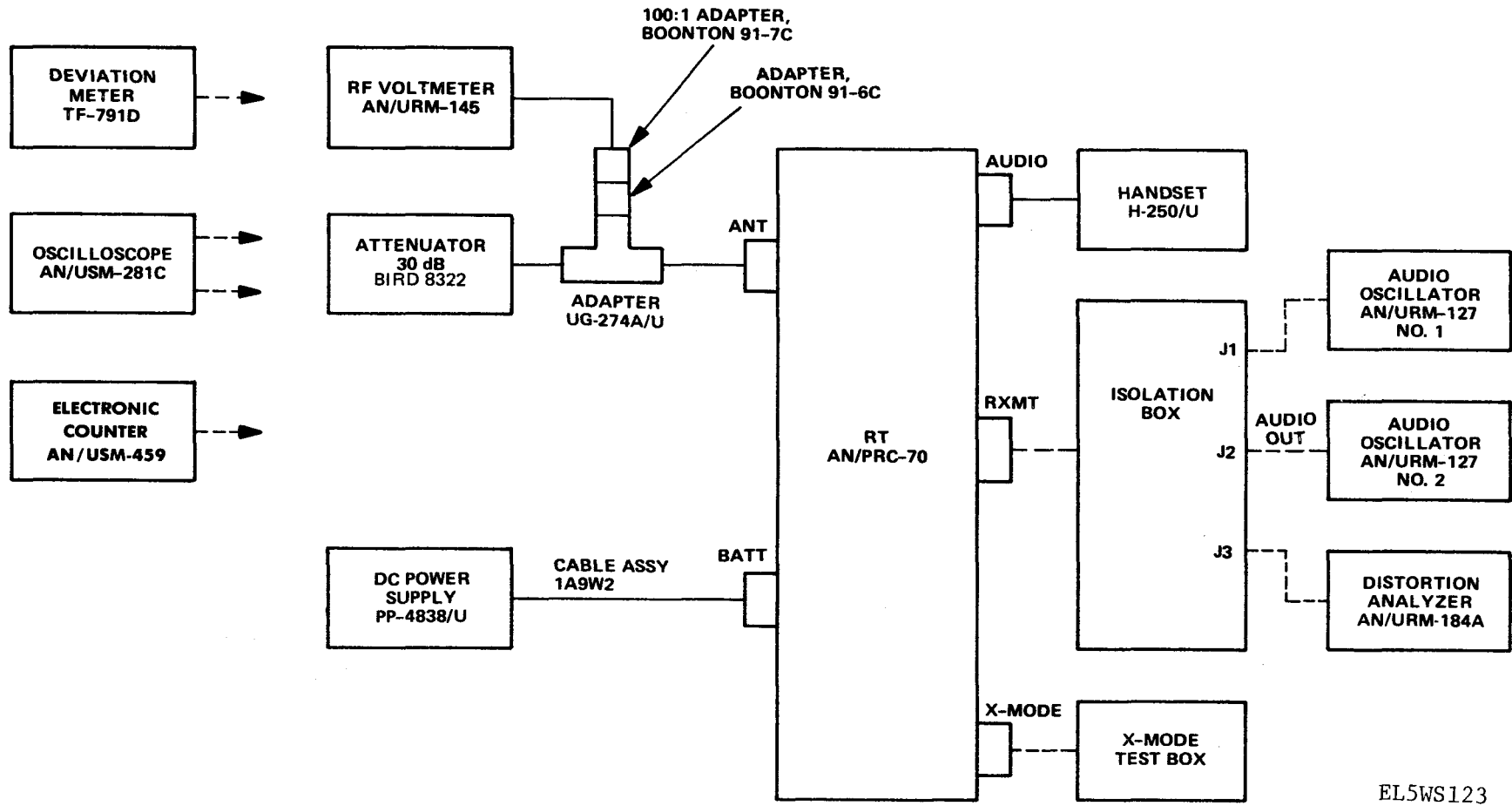

EL5WS123

Figure 4-82. Transmit CW/FSK test setup.

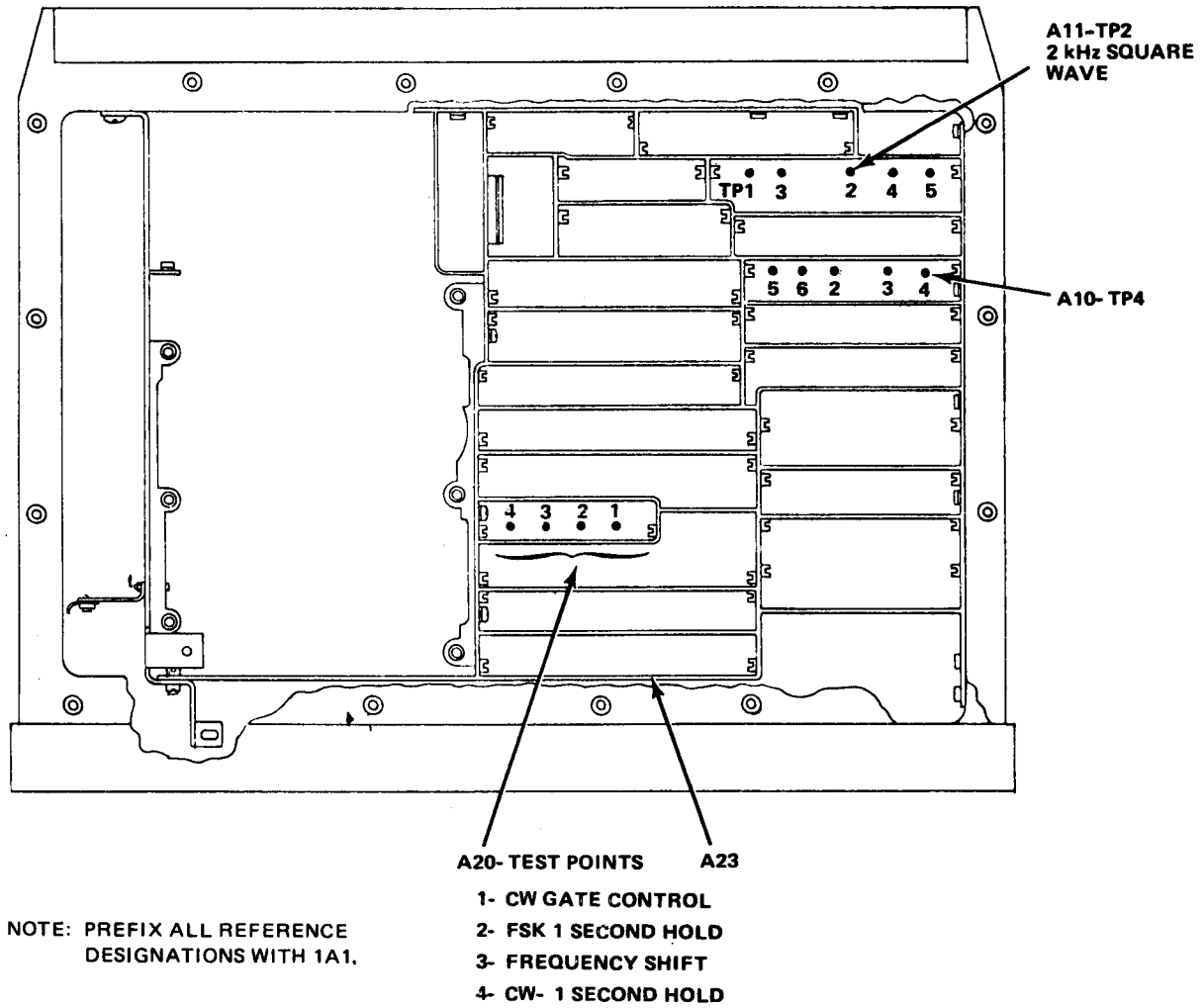

EL5WS124

Figure 4-83. Transmit CW/FSK test point locations.

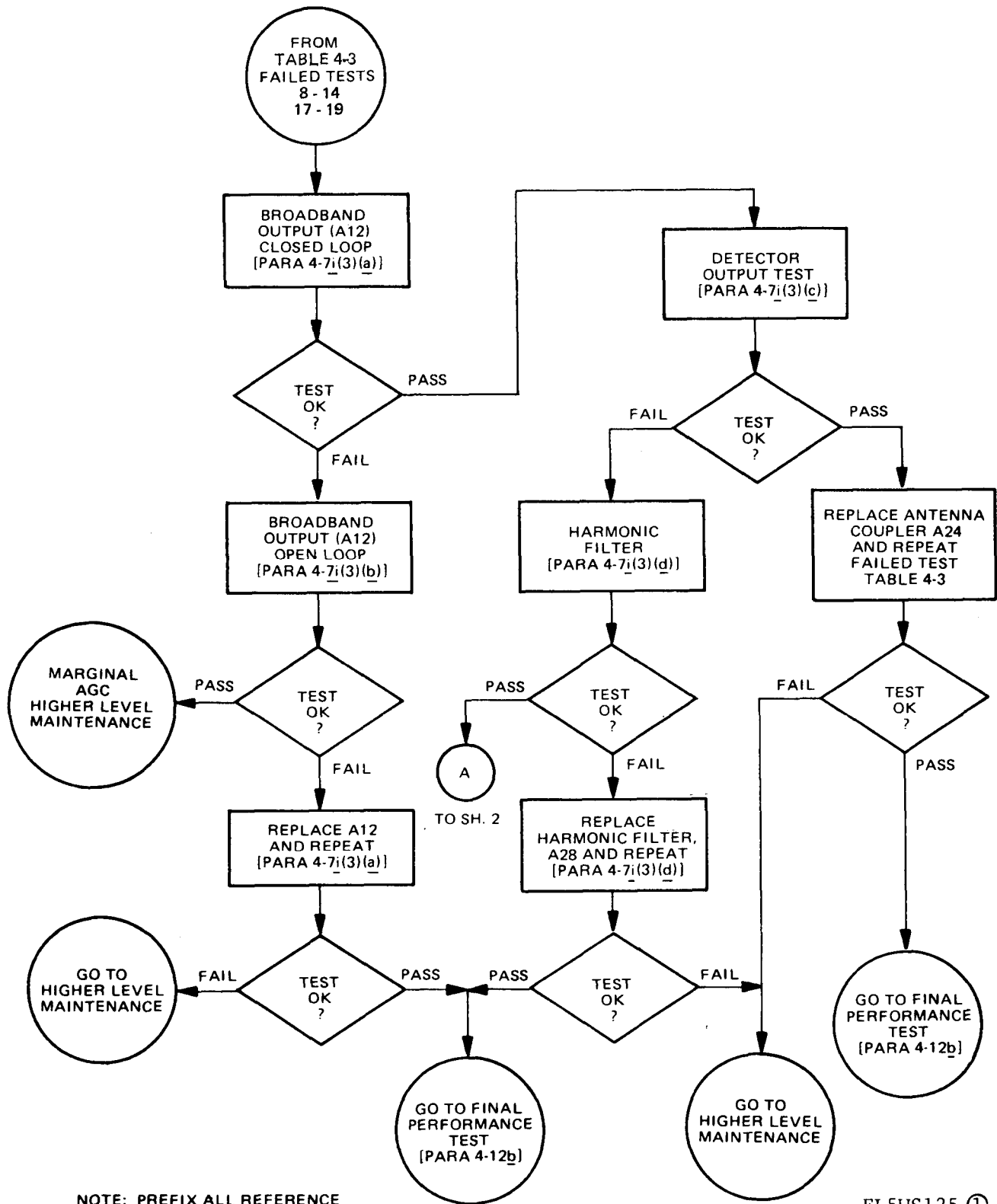

NOTE: PREFIX ALL REFERENCE DESIGNATIONS WITH 1A1

EL5WS125 ①

Figure 4-84. Transmit power out troubleshooting diagram (sheet 1 of 2).

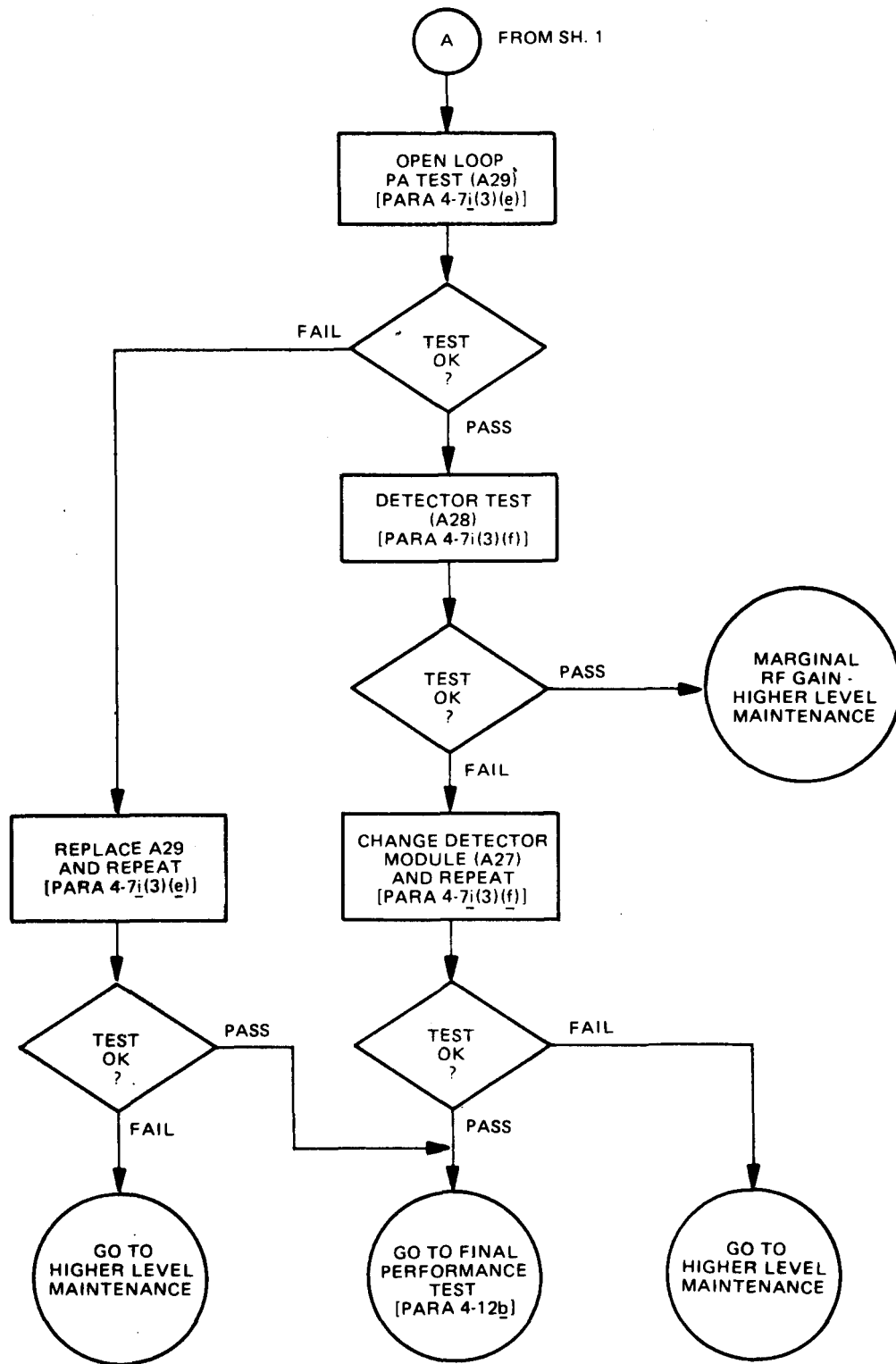

NOTE: PREFIX ALL REFERENCE DESIGNATIONS WITH 1A1

EL5WS125 ②

Figure 4-84. Transmit power out troubleshooting diagram (sheet 2 of 2).

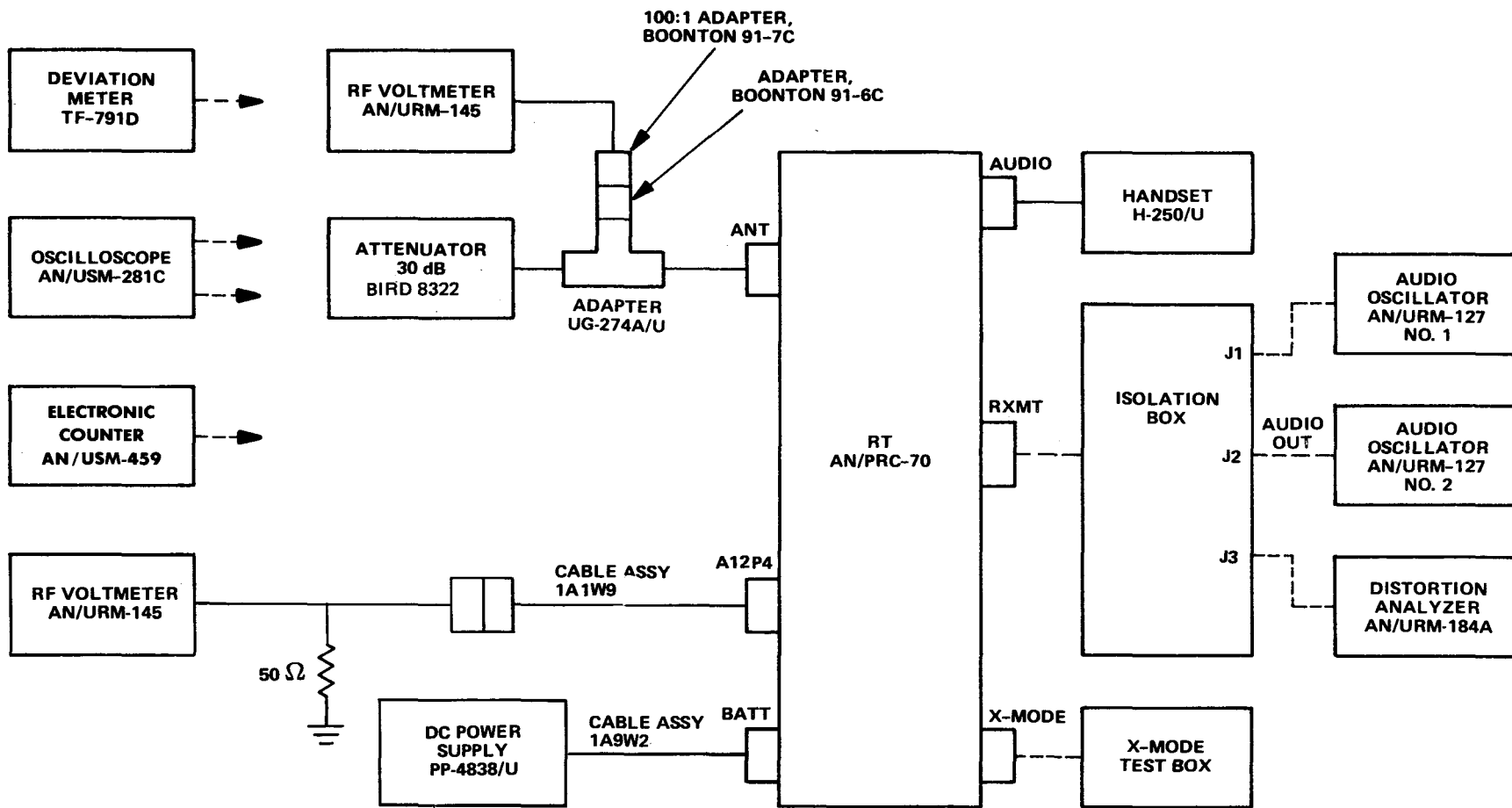
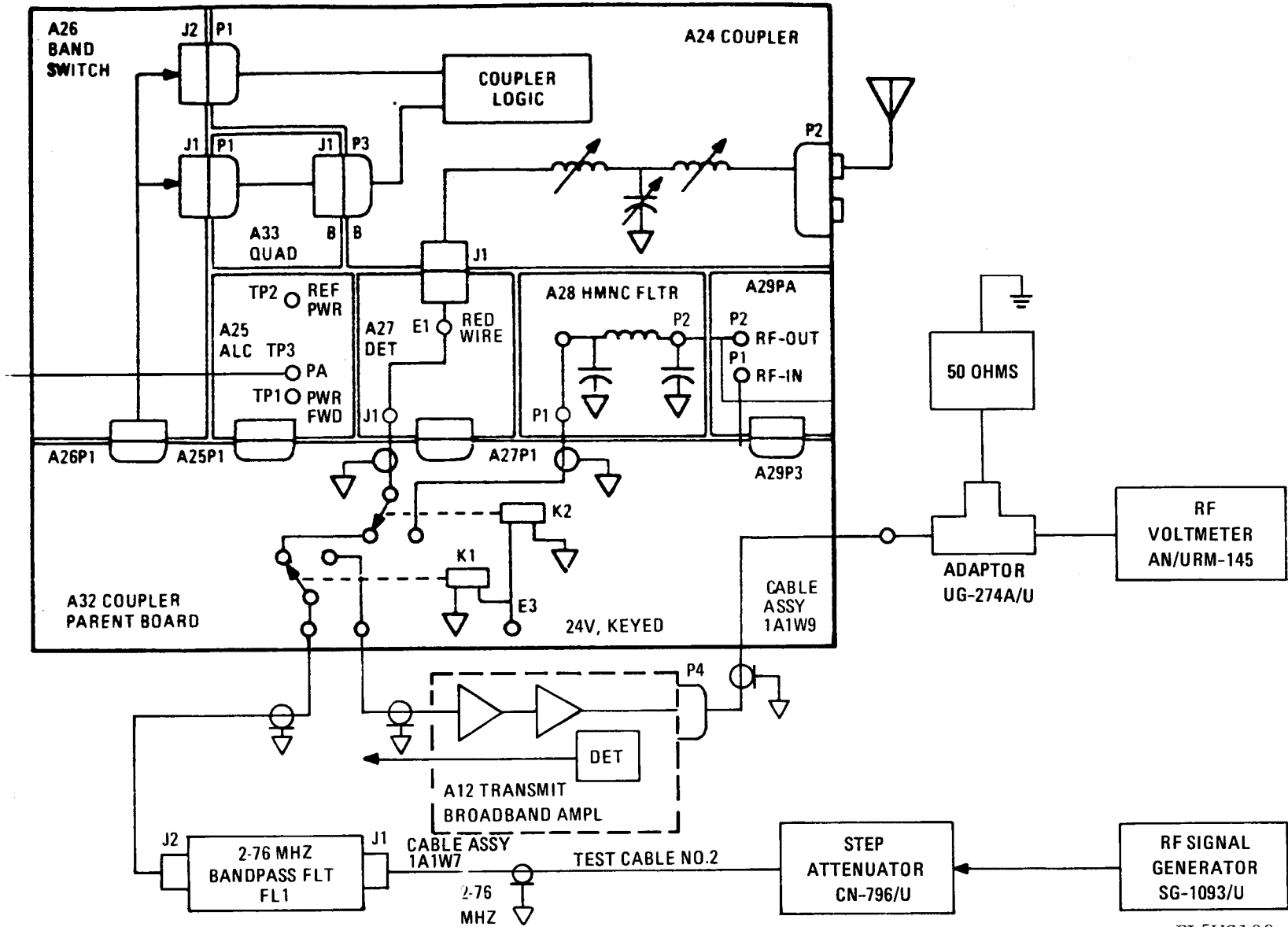

Figure 4-85. Transmit power out test setup.

EL5WS126



EL5WS138

Figure 4-86. A12 Broadband Gain test setup.

2. Set audio generator No. 1 to 1000 Hz (audio generator No. 2 is disconnected).

(3) *Transmit RF power output tests.*

(a) *Broadband Amplifier A12 output, closed loop.*

1. Setup equipment as shown in figure 4-85.

2. Set audio oscillator No. 1 to a frequency of 1000 Hz (audio oscillator No. 2 disconnected).

3. Set RT Mode to SSB and failed frequency.

4. Key the RT.

5. Using RF voltmeter, check to see that RF output level reads between 1.4 and 2.2 Vrms.

6. Unkey the RT.

(b) *Broadband Amplifier A12 output, open loop.*

1. Setup equipment as shown in figure 4-86.

2. Set signal generator to 300 mV.

3. Set step attenuator to 26 dB.

4. Set RT to LO PWR at failed frequency.

5. Key the RT and slowly change signal generator output until RF voltmeter reads 1.6 Vrms.

6. Check to see that Signal Generator output level reads less than 1.1 Vrms.

7. Unkey the RT.

(c) *Detector output test.*

1. Return RT to standard configuration.

2. Bypass Antenna Coupler, using Test Cable 3 (TC 3). See figure 4-87.

3. Key the RT in HI PWR operation.

4. Measure power output.

5. Power limits are between 28.0 and 50.0

Vrms.

6. Unkey the RT.

(d) *Harmonic Filter A28 test.*

1. Bypass PA by modifying cable configuration as shown in figure 4-87 to that shown in figure 4-88.

2. Key the RT.

3. Check to see that RF output voltage is more than 1.0 Vrms.

4. Unkey the RT.

5. Restore cables W8 and 1A1A29P1 to original connections.

(e) *Open Loop PA test.*

1. Drive the PA (A29), from the Broadband Amplifier (A12), as shown in figure 4-89. See figure 4-87 for location of 1A1A25 test points.

2. Set voltage at A25-TP3 to zero.

3. Key the RT.

4. Slowly increase the voltage at A25-TP3 until an RF output of 35.0 Vrms is obtained.

5. Voltage at A25-TP3 should be between 2.5 and 6.0 V dc.

6. Unkey the RT.

(f) *Detector test.*

1. Perform steps 1 through 4 of 4-7i(3)(e) above.

2. Measure Detector Output at A25-TP1.

3. Level should read between 4.0 and 7.0 V dc.

4. Unkey the RT.

Section IV. Maintenance of Receiver-Transmitter RT-1133/PRC-70

4-8. Adjustment and Alignment

The RT unit requires no adjustment or alignment.

4-9. Repair

Repair of the RT unit is accomplished by replacement of faulty modules with ones known to be good and a limited number of parts or the RT case. Replacement of parts not given in this section is performed by depot maintenance.

CAUTION

The minicoax cable connections on the bottom of the RT unit are held in their jacks with crimped coax retainers. To disconnect the coax cable when testing, use a pair of needle nose pliers. Bend up the retaining "ears" on the spring clips just enough to permit the cable connection to be parted.

4-10. Assembly and Disassembly

a. Removing and Replacing Radio Set Top and Bottom Cover.

(1) *Removal of top and bottom covers.*

(a) Alternately loosen 16 captive screws securing each cover to RT case.

(b) Remove cover.

(2) *Replacement of top and bottom cover.*

(a) Position cover on RT case.

(b) Alternately tighten 16 screws securing cover to RT case.

b. Removing and Replacing Modules. See figure 4-90, sheet 1 for module location.

(1) *Removal of Frequency Selector 1A1A1.*

(a) Loosen 11 captive screws that secure module to case assembly of RT unit.

(b) Remove module by gently pulling at bottom of module to separate two multipin connectors.

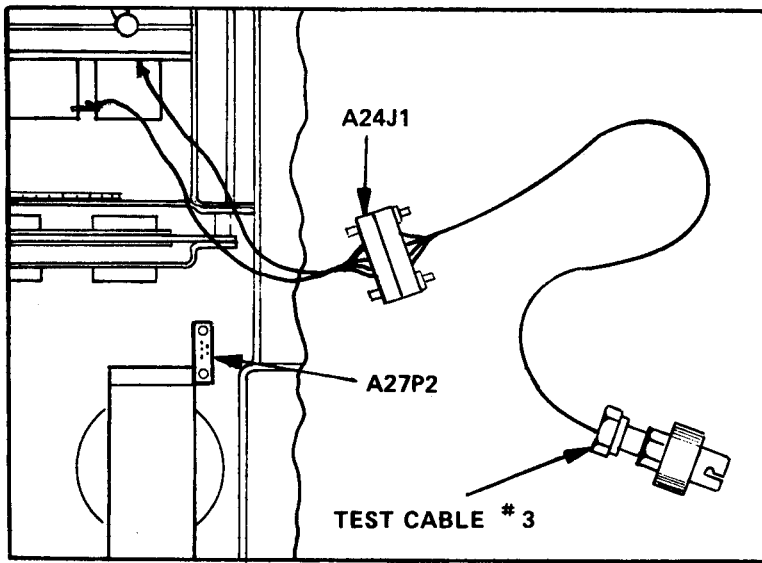
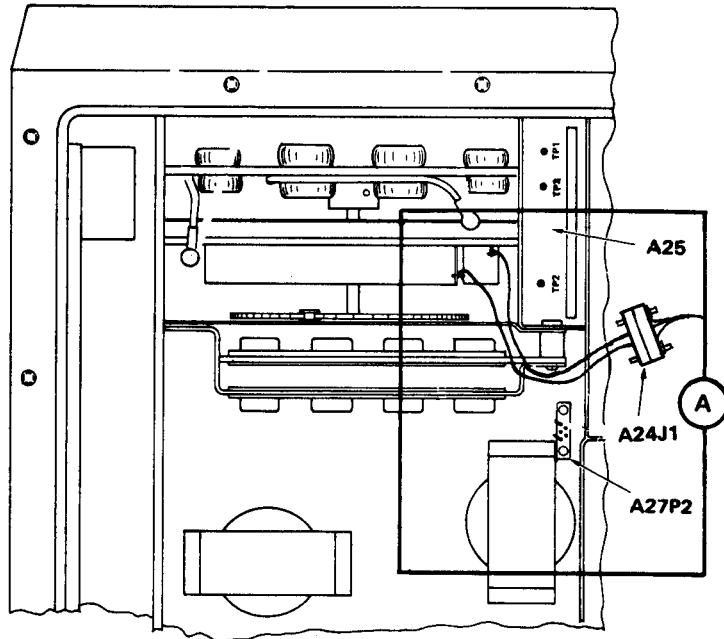

DETAIL A

EL5WS128 (i)

Figure 4-87. Closed Loop PA test setup (sheet 1 of 2).

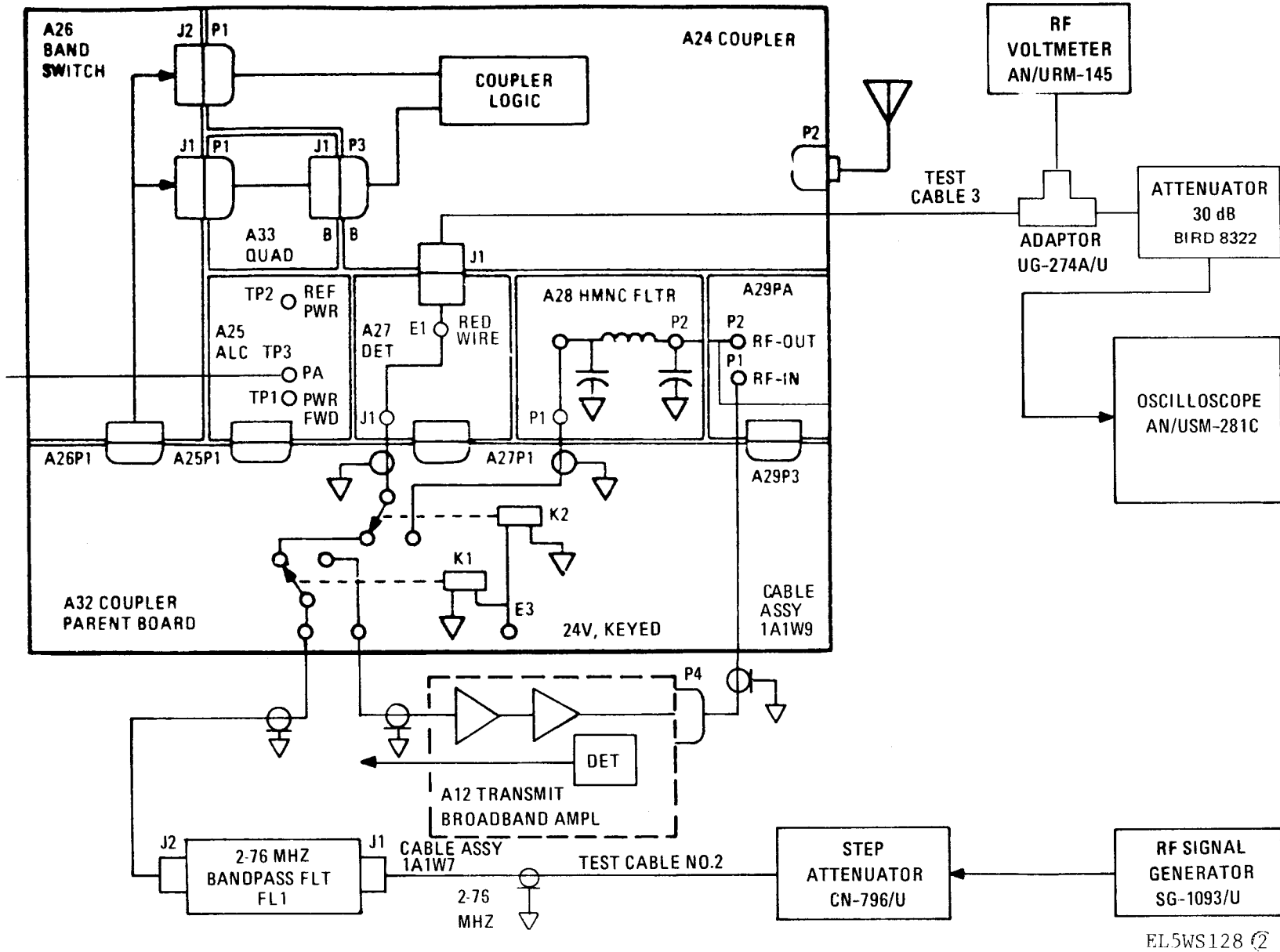
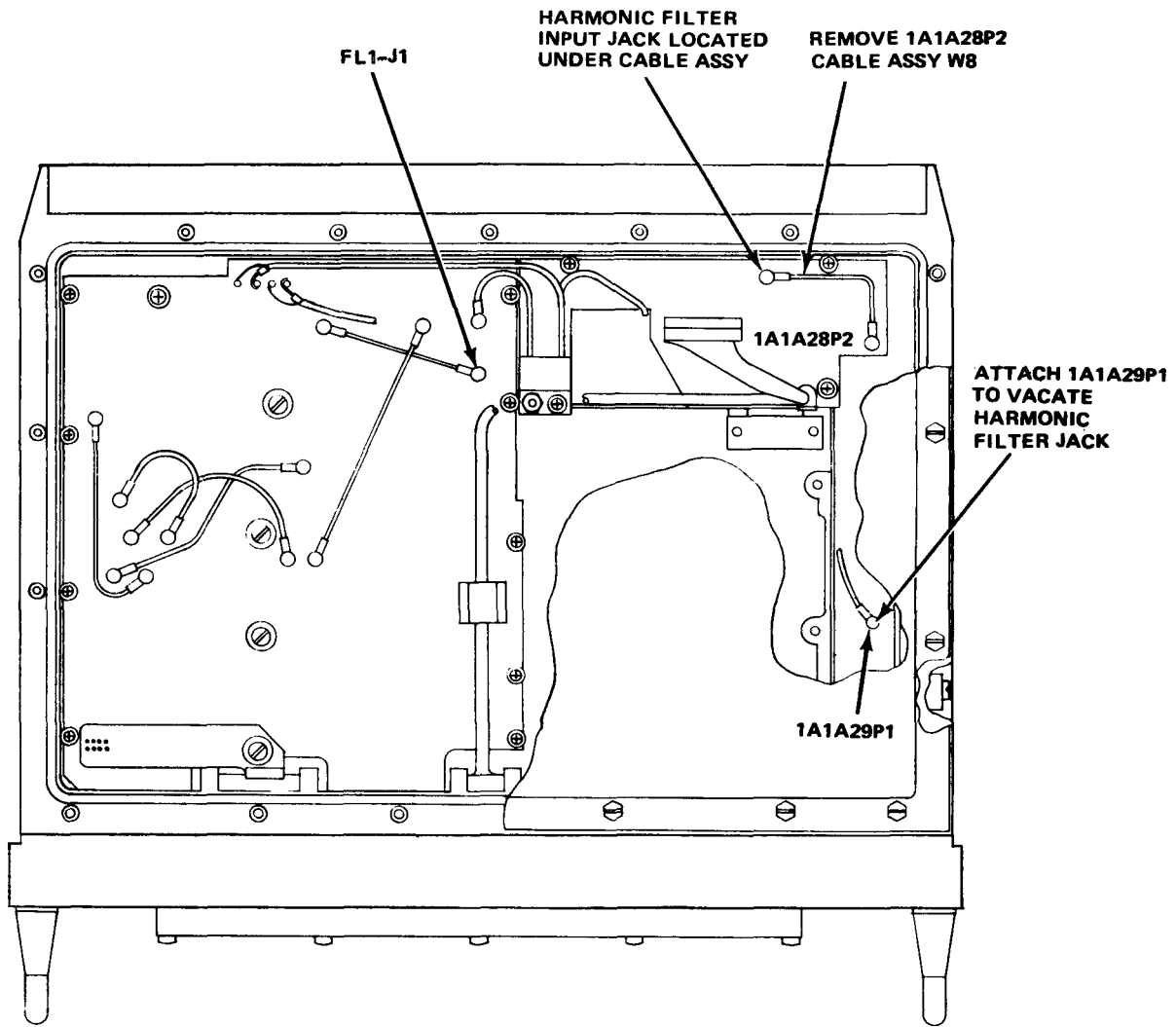

Figure 4-87. Closed Loop PA test setup (sheet 2 of 2).



EL5WS129

Figure 4-88. Harmonic Filter/Bandswitch test setup.

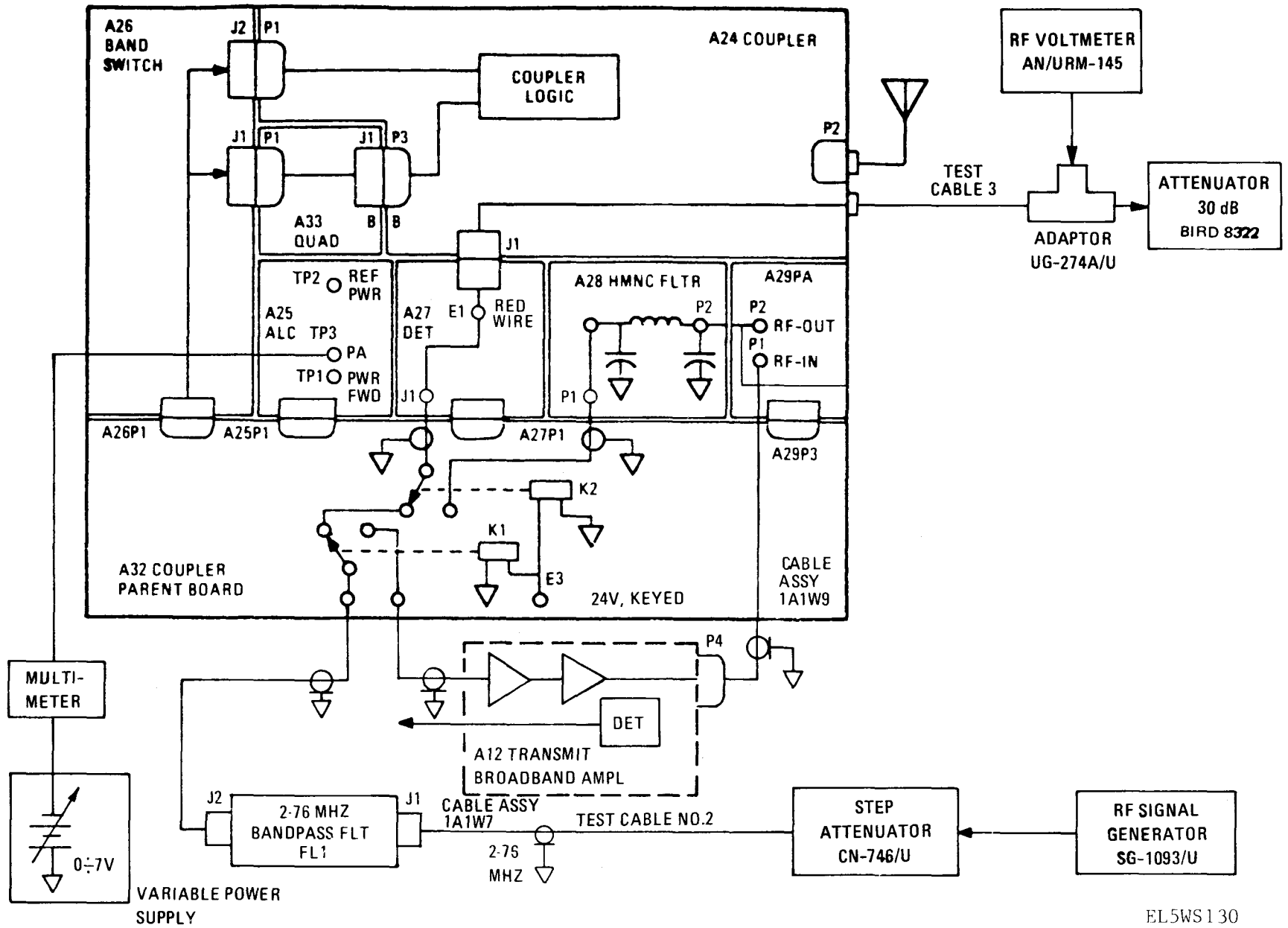
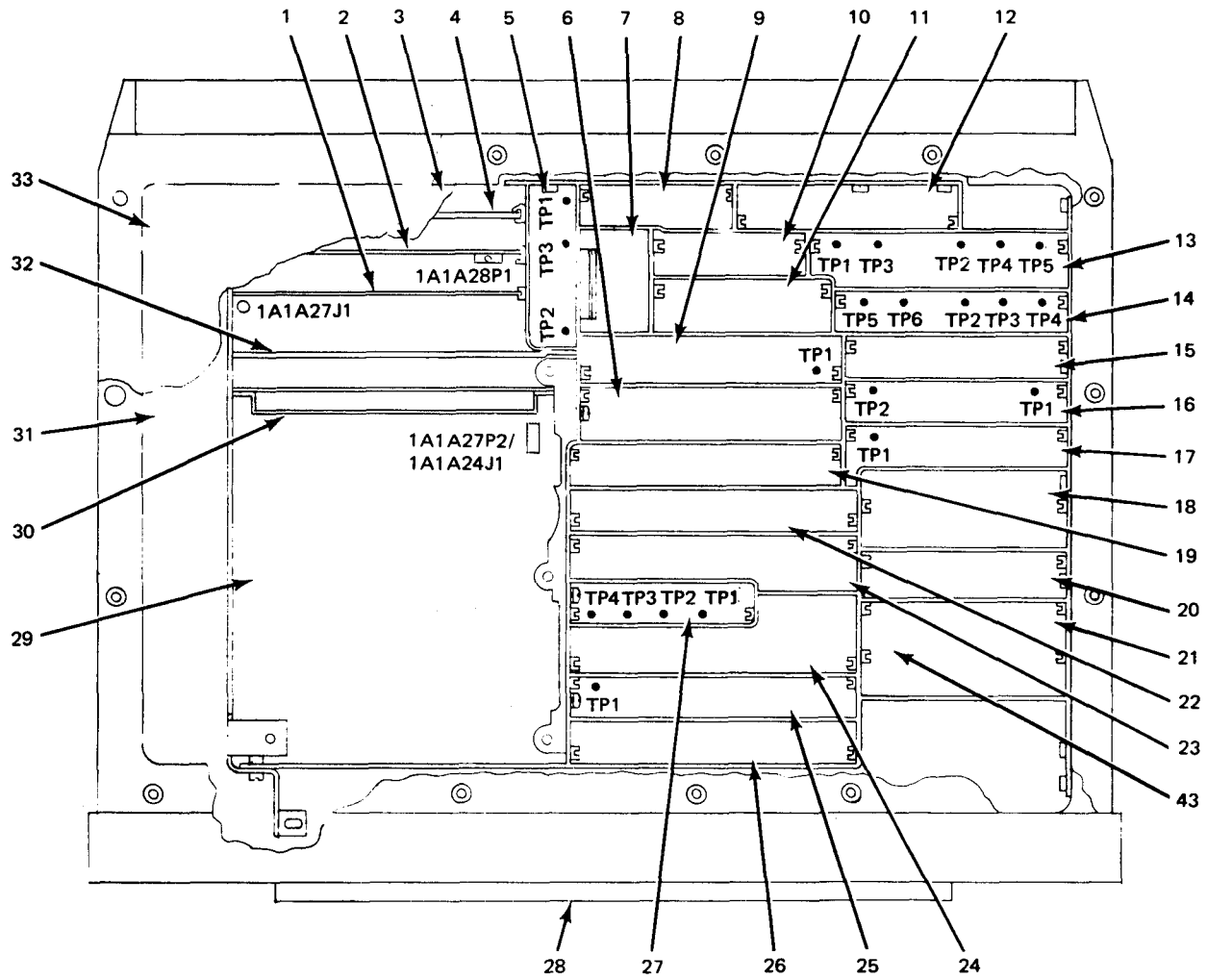

Figure 4-89. Open Loop PA test setup.

EL5WS130



TOP VIEW

EL5WS131 ①

Figure 4-90. Module locations (sheet 1 of 2).

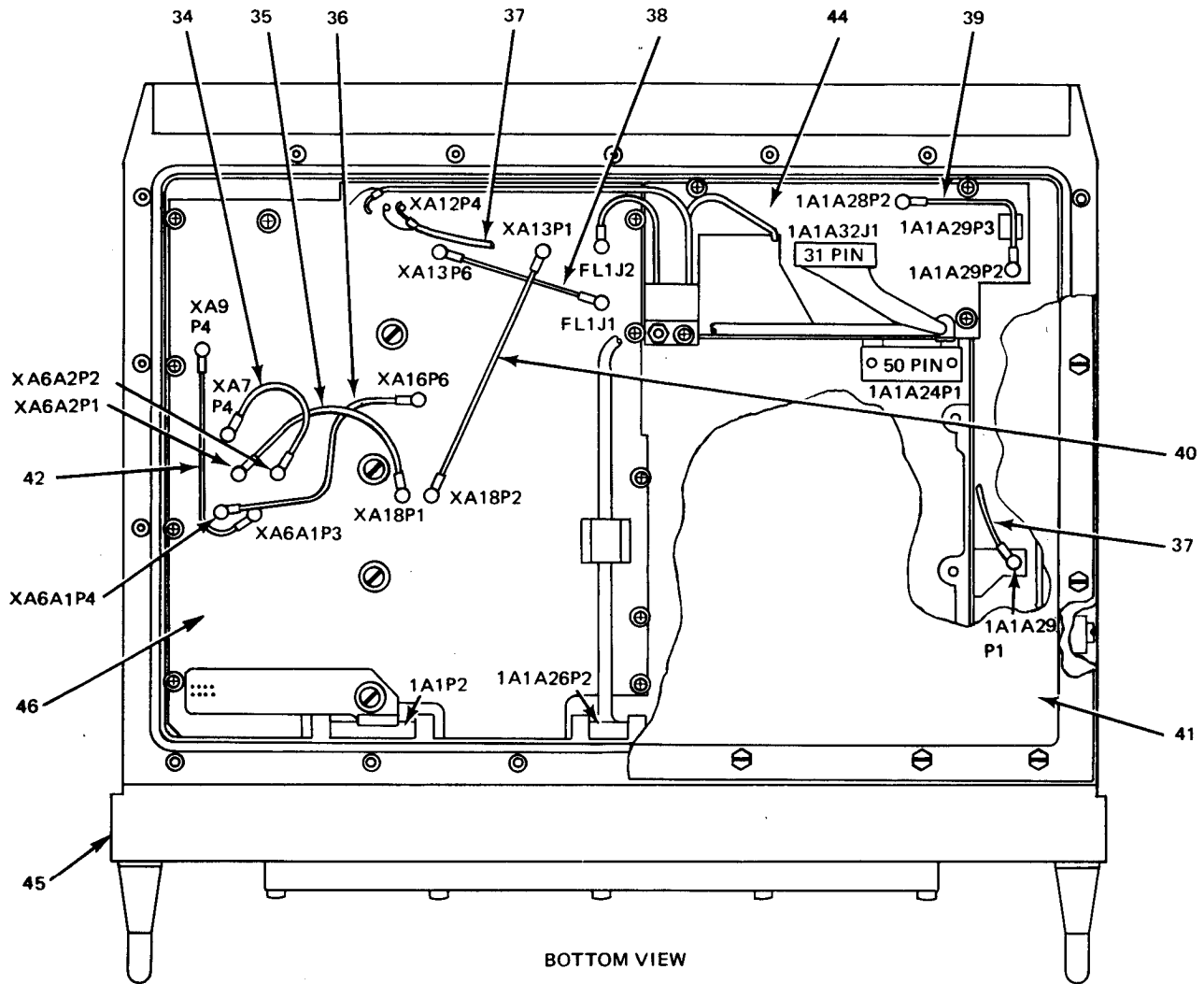

- | | |
|--|---|
| <ol style="list-style-type: none"> 1. DETECTOR 1A1A27 2. SHIELD ASSEMBLY 3. METAL COVER 4. HARMONIC FILTER 1A1A28 5. ALC 1A1A25 6. SECOND MIXER 1A1A16 7. BANDPASS FILTER 1A1FL1 8. POWER AND TR RELAY 1A1A2 9. FIRST IF AGC AND GAIN 1A1A15 10. UPCONVERTER 1A1A13 11. FIRST IF SELECTIVITY 1A1A14 12. XMIT BROADBAND 1A1A12 13. OSCILLATOR DIGITAL DIVIDER 1A1A11 14. OSCILLATOR DISTRIBUTOR 1A1A10 15. SERIAL LOWER LOOP 1A1A9 16. UPPER LOOP PHASE DETECTOR 1A1A8 17. UPPER LOOP DIVIDER 1A1A7 18. TRANSLATOR 1A1A6 19. SECOND IF 1A1A17 20. 455 KHZ IF GAIN 1A1A3 21. -5V REGULATOR 1A1A5 22. VFO PUMP 1A1A18 23. MODULATOR/SQUELCH 1A1A21 | <ol style="list-style-type: none"> 24. IF SELECTIVITY 1A1A19 25. 455 KHZ IF DETECTOR 1A1A22 26. AUDIO 1A1A23 27. DC CONTROL 1A1A20 28. FREQUENCY SELECTOR 1A1A1 29. COUPLER 1A1A24 30. QUAD ASSEMBLY 1A1A33 31. POWER AMPLIFIER AND DIVIDER 1A1A29 32. BANDSWITCH 1A1A26 33. TOP COVER 34. CABLE ASSEMBLY 1A1W2 35. CABLE ASSEMBLY 1A1W3 36. CABLE ASSEMBLY 1A1W4 37. CABLE ASSEMBLY 1A1W9 38. CABLE ASSEMBLY 1A1W7 39. CABLE ASSEMBLY 1A1W8 40. CABLE ASSEMBLY 1A1W5 41. BOTTOM COVER 42. CABLE ASSEMBLY 1A1W1 43. +5, +10V REGULATOR 1A1A4 44. COUPLER, PARENT BOARD 1A1A32 45. CHASSIS ASSEMBLY 1A1A30 46. RECEIVER/EXCITER PARENT BOARD 1A1A31 |
|--|---|

EL5WS131 ②

Figure 4-90. Module locations (sheet 2 of 2).

(2) *Replacement of Frequency Selector 1A1A1.*

(a) Insert module into case assembly of RT unit, and carefully mate two multipin connectors.

(b) Tighten 11 screws to secure module to case assembly.

(3) *Removal of 1A1A2 through 1A1A23, 1A1A25 and 1A1FL1 (fig. 4-91).*

(a) Remove top and bottom covers (para 4-10a(1)).

CAUTION

When removing module with screwdriver be careful not to bend or bow the printed circuit card.

(b) Insert screwdriver tip in slot from component side of PC board.

(c) Using compartment edge for leverage, pry module from connector.

(4) *Replacement of Modules 1A1A2 through 1A1A23, 1A1A25 and 1A1FL1.* To replace a module, insert it in slides and push down until module connector mates firmly. After replacing 1A1FL1, from

bottom of RT unit connect cable 1A1W7 to 1A1FL1J1 and contact K1-(com) cable at 1A1FL1J2.

(5) *Removal of Coupler 1A1A24.*

(a) Remove top and bottom covers (para 4-10a(1)).

(b) Select either automatic or manual procedures below to align coupling positions between coupler 1A1A24 and bandswitch 1A1A26:

Automatic.

1. Connect battery or external power to RT unit.

2. Set POWER switch to RCV ONLY position. Set FREQUENCY Selectors to read 10.000 MHz.

3. Set POWER switch to OFF and disconnect battery or external power.

4. Remove top and bottom covers from RT unit.

Manual.

1. If battery of external power is not available remove top and bottom covers from RT unit and metal cover (item No. 3, fig. 4-90, sheet 1).

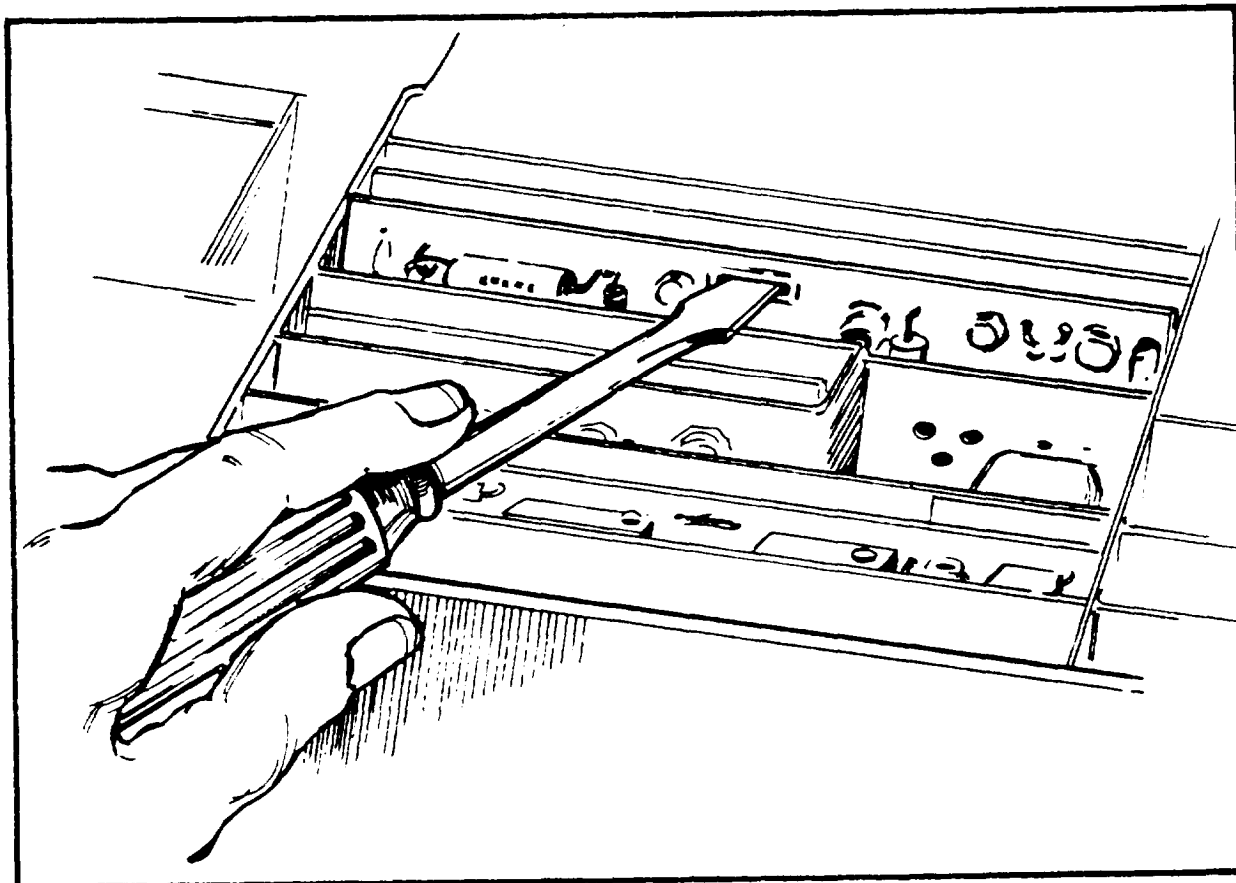

EL5WS118

Figure 4-91. Module removal.

2. Locate gear (fig. FO-7, view A) near bandswitch motor on underside of RT unit. Manually rotate gear until coupling positions indicated in figure FO-7, view A is achieved.

(c) Remove connector 1A1A27P2 (fig. 4-90, sheet 1) from 1A1A24J1.

(d) Remove 1A1A28 (para 4-10b(10)).

(e) Remove 1A1A27 (para 4-10b(8)).

(f) Remove 1A1A24P3 from 1A1A33J1 shown in figure 4-90, sheet 2.

(g) From top of RT unit, loosen six screws holding module in place (fig. FO-7, view B).

CAUTION

The six screws that hold the coupler module into the chassis also retain the multilayered circuit boards that comprise the coupler module. To avoid damaging circuit boards and components when removing the coupler module from the chassis, hold the loose portions of the module so that the circuit boards are not allowed to separate.

(h) From top of the RT unit, gently tap module out with flat-blade screwdriver by alternating taps on front-left corner and right-rear corner of module. With a small screwdriver Fed Spec GGG-S-121 Type 1 Class 2, gently pry connector P1 until it separates from the chassis side. See figure FO-7, view B.

(i) Remove module through bottom of RT unit.

(6) *Replacement of Coupler 1A1A24.* See figure FO-7.

(a) Perform step 4-10b(5)(a) (automatic) and/or 4-10b(5)(a) (manual) to align coupler 1A1A24 and bandswitch 1A1A26 coupling positions.

(b) Insert module through bottom of RT unit and push up to mate connectors.

(c) Secure six screws and washers removed in step 4-10b(5)(d). Tighten screws until module is pulled up into RT unit.

(d) Connect 1A1A24P3 to 1A1A33J1 and 1A1A27P2/1A1A24J1. Replace RT unit top and bottom covers as described in paragraph 4-10a(2).

(7) *Removal and Replacement of Bandswitch 1A1A26.* Removal and replacement of this assembly is performed at depot level maintenance only.

(8) *Removal of Detector 1A1A27.* See figure FO-7.

(a) Remove top and bottom covers (para 10a(1)).

(b) Set Frequency Selectors to 10.0000 MHz.

(c) Remove connectors between K2 (Com) and 1A1A27J1; 1A1A27P2/1A1A24J1 (fig. 4-90 Sht 1).

(d) Remove detector 1A1A27 by inserting screwdriver into slot and carefully prying upward until module is released.

(9) *Replacement of Detector 1A1A27.*

(a) Align coupling positions of detector 1A1A27 and bandswitch 1A1A26 (fig. FO-7, view A) as shown.

(b) Insert detector 1A1A27 into slides and press down until 1A1A27P1 connector mates firmly.

(c) Connect 1A1A27P2/1A1A24J1 and coaxial connector from K2-common to 1A1A27J1.

(d) Replace top and bottom RT covers and metal cover as described in paragraph 4-10a(2).

(10) *Removal of Harmonic Filter 1A1A28.* (See fig. FO-7, view A.)

(a) Select either automatic or manual procedures below to align coupling positions between coupler 1A1A24 and bandswitch 1A1A26:

Automatic.

1. Connect battery or external power to RT unit.

2. Set POWER switch to RCV ONLY position. Set FREQUENCY Selectors to read 17.0000 MHz.

3. Set POWER switch to OFF and disconnect battery or external power.

4. Remove top and bottom covers from RT unit as described in paragraph 4-10a(1).

Manual.

1. If battery or external power is not available remove top and bottom covers from RT unit as described in paragraph 4-10a(1).

2. Locate gear (fig. FO-7, view A) near bandswitch motor on underside of RT unit. Manually rotate gear until couplings are positioned 180 degrees opposite of position indicated for coupler 1A1A24.

(b) Disconnect cable between 1A1A28P1 (fig. 4-90, sheet 1) and contact K2-(NO) which is located on shield assembly between harmonic filter 1A1A28 and detector 1A1A27, and cable 1A1W8 at 1A1A28P2.

(c) Remove harmonic filter 1A1A28 by inserting screwdriver into slot and carefully prying upward until filter is released.

(11) *Replacement of Harmonic Filter 1A1A28.*

(a) Align RT unit and filter couplings as indicated in paragraph 4-10b(10)(a) (automatic or 4-10b(10)(a) (manual).

(b) Insert module into proper track and press down until 1A1A28P2 mates with coaxial connector on underside of RT unit.

(c) Connect cable from 1A1A28P1 to contact K2-(NO) located on shield assembly between harmonic filter 1A1A28 and detector 1A1A27.

(d) Replace RT unit top and bottom covers as described in paragraph 4-10a(2).

(12) *Removal of Power Amplifier and Driver 1A1A29.*

(a) Remove top and bottom covers from RT unit as described in paragraph 4-10a(1).

(b) Use a 9/64-inch Allen wrench and remove six screws with seal washers, on outside of RT unit, that are used to attach power amplifier and driver 1A1A29 to RT case. Retain hardware for reassembly.

(c) Remove cable 1A1W9 from connector.

(d) Remove power amplifier and driver 1A1A29 from RT unit by pushing up from bottom until module connectors are released.

(13) *Replacement of Power Amplifier and Driver 1A1A29.*

(a) Insert power amplifier and driver 1A1A29 into RT module enclosure, and press carefully to seat module connectors.

CAUTION

When mounting power amplifier and driver 1A1A29 do not use any hardware other than that designed for mounting. Screws of improper length will cause mechanical or electrical damage to the RT unit.

(b) Align module with mounting holes and insert six screws with seal washers.

(c) Tighten screws with 9/64-inch Allen wrench to secure module to RT unit.

(d) Replace cable 1A1W9 on connector.

(e) Replace top and bottom covers on RT unit as described in paragraph 4-10a(2).

(14) *Removal and Replacement of 1A1A30, 1A1A32 assemblies.* Removal and replacement procedures for these assemblies are performed at depot level maintenance only.

(15) *Removal of Quad Assembly 1A1A33.*

(a) Remove coupler 1A1A24 as indicated in paragraph 4-10b(5).

(b) Remove quad assembly 1A1A33 with two screws from bandswitch 1A1A26. The two screws are different sizes.

(16) *Replacement of Quad Assembly 1A1A33.*

(a) Place quad assembly 1A1A33 onto bandswitch 1A1A26 and tighten with two screws. Ensure the screws are in the proper slots.

(b) Replace coupler 1A1A24 as described in paragraph 4-10b(6).

c Removing and Replacing RT Case Parts and Assemblies. See figure FO-8 for location of parts.

(1) *Removal of Lamps in Frequency Selector 1A1A1.*

(a) Remove RT unit top cover as described in step 4-10a(1).

(b) Remove lamp using tweezers.

(2) *Replacement of Lamps in Frequency Selector 1A1A1.*

(a) Replace lamp using tweezers.

(b) Replace RT unit top cover as described in Step 4-10a(2).

(3) *Removal of Cable 1A1W9.* Unsolder cable 1A1W9 from parent board 1A1A31. Refer to figures 4-90, sheet 2 and FO-5, sheet 1.

(4) *Replacement of Cable 1A1W9.* Solder cable 1A1W9 onto parent board 1A1A31. Refer to figures 4-90, sheet 2 and FO-5, sheet 1.

(5) *Removal of Fuse 1A1A2F1 and 1A1A2F2.*

(a) Remove module 1A1A2 from RT unit. Refer to paragraph 4-10b(3) and figure 4-90, sheet 1.

(b) Unsolder and remove fuse from module 1A1A2.

(6) *Replacement of Fuse 1A1A2F1.*

(a) Solder fuse onto module 1A1A2.

(b) Insert module 1A1A2 into RT unit. Refer to paragraph 4-10b(4) and figure 4-90, sheet 1.

(7) *Removal of Zener Diode 1A1A2CR4.*

(a) Remove module 1A1A2 from RT unit. Refer to paragraph 4-10b(3) and figure 4-90, sheet 1.

(b) Unsolder zener diode from module 1A1A2. Notice direction of zener diode.

(8) *Replacement of Zener Diode 1A1A2CR4.*

(a) Solder zener diode onto module 1A1A2 in the correct direction.

(b) Insert module into RT unit. Refer to paragraph 4-10b(4).

(9) *Removal of BNC ANT Connector 1A1A30J1.*

(a) Remove RT unit top cover as described in paragraph 4-10a(1).

(b) Remove RT unit bottom cover as described in paragraph 4-10a(1).

(c) Remove frequency selector 1A1A1 as described in paragraph 4-10b(1).

(d) Using special wrench, loosen hex nut securing ANT connector to RT case (figure FO-8, view A) and slide hex nut onto wires from connector.

(e) Slide terminal lug and lockwasher off connector onto wires.

(f) Pull connector through hole in RT case to gain access to wires soldered to internal components of RT case.

(g) Identify and temporarily tag wires connected from connector to internal components of RT case.

(h) Unsolder two wires from connector to internal components of RT case.

(i) Remove connector from case (including preformed gasket).

(j) Remove lockwasher, terminal lug, and hex nut from unsoldered wires.

(10) *Replacement of BNC ANT Connector 1A1A3W1.*

(a) Assemble hex nut, terminal lug, and lockwasher to wires unsoldered in paragraph 4-10c(9).

(b) Assemble preformed packing over threads of BNC connector, figure FO-8, view A.

(c) Position BNC connector for insertion into hole in RT case, observing location of flat cut out but do not insert.

(d) Solder two wires to components unsoldered in paragraph 4-10c(9)(h).

(e) Remove tags temporarily attached to wires in paragraph 4-10c(9)(g).

(f) Apply sealing compound MIL-S-46163, Type II Grade N to threads of BNC connector.

(g) Insert BNC connector into hole in RT case, preformed packing tight against case.

(h) Slide lockwasher and terminal lug onto connector.

(i) Assemble hex nut to connector and tighten with special wrench.

(j) Replace frequency selector 1A1A1 as described in paragraph 4-10b(2).

(k) Replace RT unit top and bottom covers as described in paragraph 4-10a(2).

(11) *Removal of WHIP Antenna Connector Assembly 1A1A30A2.*

(a) Remove RT unit top cover as described in paragraph 4-10a(1).

(b) Remove RT unit bottom cover as described in paragraph 4-10a(1).

(c) Remove frequency selector 1A1A1 as described in paragraph 4-10b.

(d) Remove red wire from E5 (figure FO-8, view A).

(e) Remove four screws securing WHIP antenna connector to RT case (figure FO-8, view A).

(f) Pull WHIP antenna connector assembly away from case far enough to gain access to wires connecting switch 1A1A30S1 on connector assembly to internal components of RT case.

(g) Unsolder the two wires connecting switch to internal BNC connector.

(h) Remove WHIP antenna connector assembly 1A1A30A2 and preformed packing.

(12) *Replacement of WHIP Antenna Connector Assembly 1A1A30A2.*

(a) Check to see that preformed packing is in place over switch to seal space between WHIP antenna connector and RT case (figure FO-8, view A).

(b) Position WHIP antenna connector assembly for insertion into hole in RT case but do not insert.

NOTE

Switch and bracket must be positioned nearest to GND and WIRE terminal posts on RT case.

(c) Solder two wires to components unsoldered in paragraph 4-10c(11)(g).

(d) Insert WHIP antenna connector into hole in case, make sure preformed packing is seated.

(e) Insert and alternately tighten four screws securing WHIP antenna connector to RT case.

(f) Replace frequency selector 1A1A1 as described in paragraph 4-10b(2).

(g) Replace RT unit top and bottom covers as described in paragraph 4-10a(2).

(13) *Removal of WIRE Binding Post.*

(a) Remove top and bottom covers as described in paragraph 4-10a(1).

(b) Remove Frequency Selector 1A1A1 as described in paragraph 4-10b(1).

(c) Use 7/16-inch open-end wrench to hold the wire binding post then use 3/8-inch open-end wrench to gently loosen nut (inside the RT) on the binding post without removing nut.

(d) Gently pull binding post outside the radio (wire still attached).

(e) Unsolder wire from end of binding post.

(f) Remove nut.

(g) Remove binding post and piece parts.

(14) *Replacement of WIRE binding post.*

(a) Attach piece parts to binding post.

(b) Gently slide nut onto wire.

(c) Guide wire through binding post slot on RT and solder wire to binding post before attaching binding post to RT.

(d) Secure nut to binding post (inside of RT) using a 3/8-inch open-end wrench and 7/16-inch open-end wrench.

(e) Replace Frequency Selector 1A1A1 as described in paragraph 4-10b(2).

(f) Replace top and bottom covers as described in paragraph 4-10a(2).

(15) *Removal of GND binding post.*

(a) Remove top and bottom covers as described in paragraph 4-10a(1).

(b) Remove Frequency Selector 1A1A1 as described in paragraph 4-10b(1).

(c) Remove WHIP Antenna Connector Assembly as described in paragraph 4-10c(11), steps (a) through (f).

(d) Remove WIRE Binding Post as described in paragraph 4-10c(13).

(e) Use 7/16-inch open-end wrench to hold the GND binding post then use 3/8-inch open-end wrench to gently loosen nut (inside the RT) on binding post without removing nut.

(f) Gently pull binding post outside the radio (wire still attached).

(g) Unsolder wire from end of binding post.

(h) Remove connector and piece parts.

(i) Remove nut.

(16) *Replacement of GND binding post.*

(a) Attach piece parts to binding post.

(b) Gently slide nut onto wire.

(c) Guide wire through binding post slot on RT and solder wire to binding post before attaching binding post to RT.

(d) Secure nut to binding post (inside the RT) using a 3/8-inch open-end wrench and 7/16-inch open-end wrench.

(e) Replace WIRE binding post as described in paragraph 4-10c(14).

(f) Replace WHIP Antenna Connector Assembly as described in paragraph 4-10c(12), steps (a) through (e).

(g) Replace Frequency Selector 1A1A1 as described in paragraph 4-10a(2).

(h) Secure RT unit top and bottom covers as described in paragraph 4-10a(2).

(17) *Removal of battery connector.*

(a) Remove RT unit top cover as described in paragraph 4-10a(1).

(b) Remove RT unit bottom cover as described in paragraph 4-10a(1).

(c) Remove two screws securing battery connector to RT case and to shield assembly (figure FO-8, view B).

(d) Pull battery connector away from RT unit.

(e) Identify and temporarily tag connector pins on inside of connector.

(f) Pull connector pins (with wires attached) free of battery connector.

(g) Remove battery connector and gasket free from RT case.

(h) Remove all residue of damaged gasket and adhesive from gasket groove.

(18) *Replacement of battery connector* (figure FO-4 and FO-8, view B).

CAUTION

Connector can be positioned upside down.

(a) Apply adhesive RTV-734 to both sides of battery connector gasket.

(b) Remove identification tags temporarily attached to battery connector pins in paragraph 4-10c(17)(e).

(c) Position battery connector and gasket on RT case.

(d) Insert two screws through battery connector, gasket, and RT case and thread into holes in shield assembly.

(e) Alternately tighten two screws to secure battery connector to RT case and shield assembly.

(f) Replace RT unit top and bottom covers as described in paragraph 4-10a(2).

(19) *Removal of battery case preformed gasket.*

(a) Remove battery case from rear of RT unit.

(b) Remove damaged battery case gasket from groove on inside edge of RT case (figure FO-8, view B).

(c) Remove all residue of damaged gasket and adhesive from gasket groove in RT case.

(20) *Replacement of new battery case preformed gasket.*

(a) Clean preformed battery case gasket groove on inside of RT case, (figure FO-8, view B), of all dust, dirt, moisture, and other foreign material.

(b) Apply small amounts of Scotchgrip adhesive at approximate two-inch spacing on bottom of gasket groove.

(c) Install preformed gasket in groove of RT case.

(d) Press gasket firmly in place.

(e) After Scotchgrip adhesive has cured, apply lubricant FS3452 between preformed gasket and RT case.

(f) Replace battery case on rear of RT unit.

(21) *Removal of RT cover gaskets for top and bottom covers.*

(a) Remove top and bottom covers of RT unit as described in paragraph 4-10a(1).

(b) Remove damaged gasket material from groove on inside edge of RT case (figure FO-8, view B).

(c) Remove all residue of damaged gasket material and adhesive from gasket groove in RT case.

(22) *Replacement of RT cover gasket for top and bottom covers.*

(a) Clean gasket groove on inside of RT case of all dust, dirt, moisture, and other foreign material (figure FO-8, view B).

(b) Apply small amount of RTV-734 adhesive along bottom of gasket groove in RT case.

NOTE

Metal edge of gasket material must be toward inside edge of gasket groove in RT case.

(c) Install gasket material in groove of RT case, when trimming to proper length cut diagonally.

(d) Press gasket material firmly in place.

(e) Replace RT unit top and bottom covers as described in paragraph 4-10a(2).

(23) *Removal of gasket from Front Panel Assembly 1A1A1.*

(a) Remove frequency selector 1A1A1 as described in paragraph 4-10b(1).

(b) Remove damaged gasket material from groove on inside edge of front panel assembly.

(c) Remove all residue of damaged gasket material and adhesive from gasket groove in front panel assembly.

(24) *Replacement of gasket on Front Panel Assembly 1A1A1.*

(a) Clean gasket groove on edge of front panel assembly of all dust, dirt, moisture, and other foreign material.

(b) Apply small amount of RTV-734 adhesive along bottom of gasket groove in front panel assembly.

NOTE

Metal edge of gasket material must be toward inside edge of gasket groove in front panel assembly.

(c) Install gasket material in groove of front panel assembly, when trimming to proper length cut diagonally.

(d) Press gasket material firmly in place.

(e) Replace frequency selector 1A1A1 as described in paragraph 4-10b(2).

(25) *Removal of Connector Assembly 1A1A30A1.*

(a) Remove RT unit top cover as described in paragraph 4-10a(1).

(b) Remove frequency selector 1A1A1 as described in paragraph 4-10b(1).

(c) Disconnect connector 1A1A30A1P1 from receiver/exciter parent board connector 1A1A31J1 (figure FO-5, sheet 1).

(d) Loosen and remove locknut from AUDIO connector 1A1A30J4 (figure FO-8, view C).

(e) Loosen and remove locknut from RXMT connector 1A1A30J3.

(f) Loosen and remove locknut from XMODE connector 1A1A30J5.

(g) Remove connector assembly from RT unit.

(26) *Replacement of Connector Assembly 1A1A30A1.*

(a) Position connector assembly for insertion through frequency selector opening into RT case (figure FO-8, view C).

NOTE

Connector 1A1A30A1P1 should be toward rear of RT case and AUDIO, RXMT, and XMODE connectors should be towards front of RT case.

(b) Insert connector assembly into RT case.

(c) Feed connector AUDIO, RXMT, and XMODE connectors from inside RT case through their respective openings to outside of RT case.

(d) Apply sealing compound MIL-S-46163, Type II, Grade N to threads of connectors.

(e) Assemble locknut to AUDIO connector and tighten finger-tight.

(f) Assemble locknut to RXMT connector and tighten finger-tight.

(g) Assemble locknut to XMODE connector and tighten finger-tight.

(h) Mate connector 1A1A30A1P1 of connector assembly with connector 1A1A31J1 on receiver/exciter parent board (figure FO-5, sheet 1) and secure.

(i) Tighten locknuts on AUDIO, RXMT, and XMODE connectors.

(j) Replace frequency selector 1A1A1 as described in paragraph 4-10b(2).

(k) Replace RT unit top cover as described in paragraph 4-10a(2).

(27) *Removal of RT unit top and bottom cover dampeners.*

(a) Remove RT unit top and bottom covers as described in paragraph 4-10a(1).

(b) Remove damaged dampener from cover (figure FO-8, view D).

(c) Remove all residue of damaged dampener material from cover.

(28) *Replacement of RT unit top and bottom cover dampeners.*

(a) Clean area of removed or missing dampener on cover of all dust, dirt, moisture, and other foreign material (figure FO-8, view D).

(b) Apply small amount of EC1300 adhesive to underside of dampener.

(c) Position dampener at same location of removed or missing dampener and press firmly in place.

(d) Replace RT unit top and bottom covers as described in paragraph 4-10a(2).

(29) *Removal of self-locking screws from RT unit top and bottom covers.*

(a) Remove RT unit top and bottom covers as described in paragraph 4-10a(1).

(b) Compress collar of self-locking screw on

underside of cover and remove screw (figure FO-8, view D).

(30) *Replacement of self-locking screws in RT unit top and bottom covers.*

(a) Insert self-locking screw into hole in cover, head of screw facing outside (figure FO-8, view D).

(b) Press screw firmly into place to seat collar on underside of cover.

(c) Replace RT unit top and bottom covers as described in paragraph 4-10a(2).

Section V. Direct Support Testing Procedures

4-11. General

This section contains Final Performance tests which satisfy two basic requirements:

(1) To confirm repair of the RT unit upon identifying a faulty module and

(2) To insure operability of the RT unit prior to return to organizational maintenance.

4-12. Final Performance

Perform the procedural steps in the order given and set all controls accurately. The RT unit front panel controls are shown in figure 4-4. If the RT unit fails any test, refer to the troubleshooting tests. If RT unit fails after the second attempt to repair, send RT to higher level maintenance.

a. Final Receiver Performance Test.

(1) *Preliminary setup.*

(a) Inspect RT for external defects or damage (see chapter 2).

(b) Check to see that POWER and SQUELCH switches on RT are OFF.

CAUTION

Be sure polarity is correct when connecting the power supply to the radio.

(c) Connect RT and test equipment as shown in figure 4-92.

(d) Turn on test equipment and allow at least 30 minutes for warmup.

(e) Prepare final receive performance data sheets similar to table 4-7 for use during final receive testing. Do not write in this book.

(f) As each test is completed, one or more questions about that test must be answered by insertion of P (Pass) or F (Fail) on the data sheet.

(g) The next procedure is to determine the action required from the answer(s) to questions of (f) above.

(h) Do not begin troubleshooting procedures until directed to do so in text or figure during performance testing. If a particular trouble is indicated during the tests, and further direction is not given, it must be noted along with test data for later evaluation.

(i) Follow directions to and from additional flow diagrams and/or instructions in the text during all testing.

(j) Figure 4-93 shows the path followed while receive performance testing.

(2) *Sensitivity test.*

CAUTION

Ensure the 30 dB attenuator is connected between the ANT connector and the signal generator before turning on the RT for testing.

(a) *Sensitivity test setup.*

1. Adjust power supply to +24 ±0.5 V dc output.

2. Turn on RT unit.

3. Set VOLUME control to midrange.

4. Set distortion analyzer to VOLTMETER function and METER RANGE switch to 3 volts,

(b) *Low level sensitivity tests (No. 1, 2, and 3).*

1. Check SINAD by performing the following steps.

CAUTION

For each test to be performed in table 4-7 the RT must be set to the indicated frequency and mode, and the signal generator must be set to the indicated frequency, modulation, and level with POWER switch in position shown.

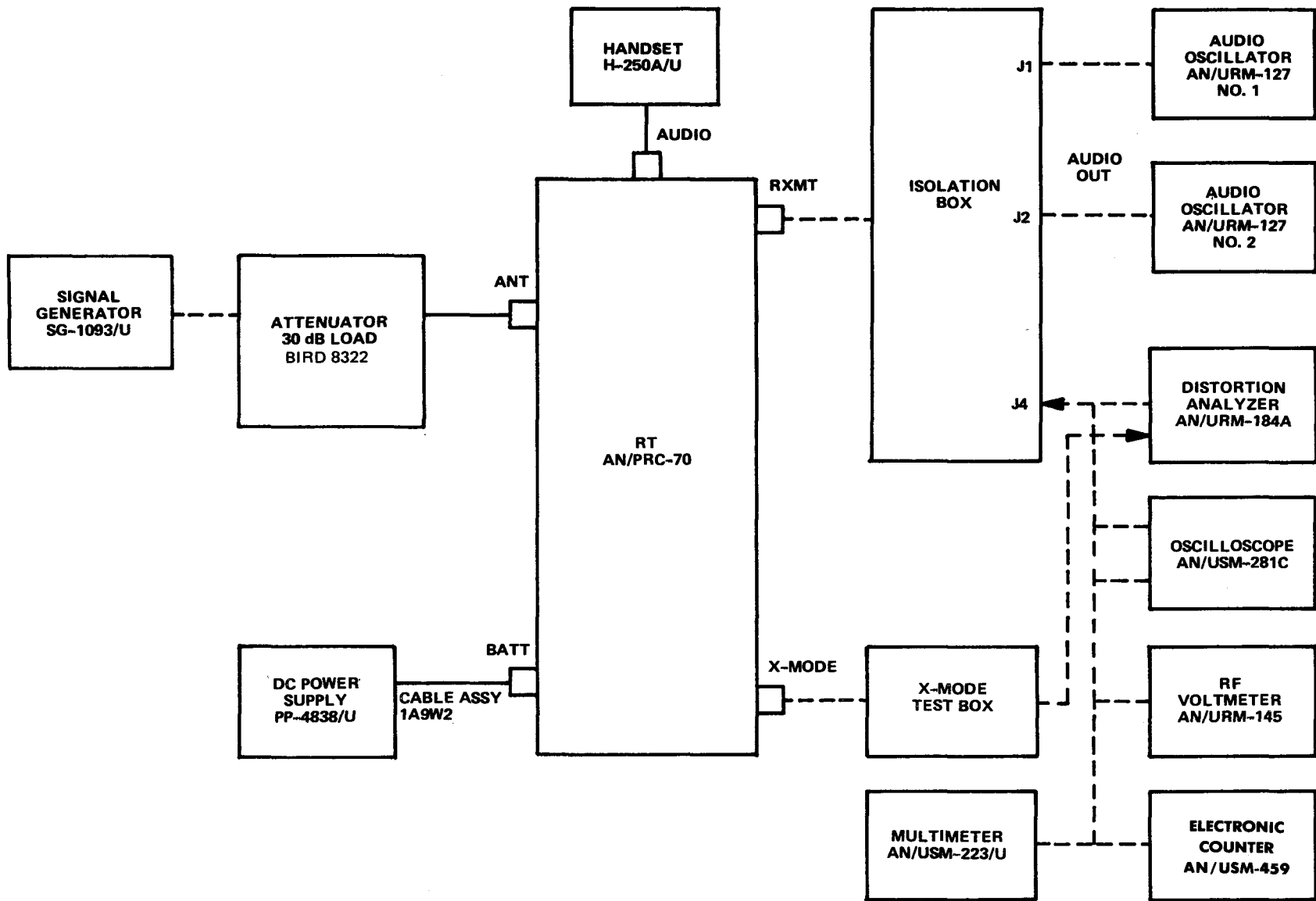

EL5WS132

Figure 4-92. Final receive performance test setup.

Table 4-7. Final Receive Performance Tests

Test No.	AN/PRC-70 Radio		Signal Generator ①			Sensitivity (dB) [Para 4-5a(2)]		AGC [Para 4-5a(3)]	Narrow Band Audio [Para 4-5a(4)]		RT # _____		Date _____	
			Freq. MHz	Mode	Freq. MHz	RF Microvolts into 30 dB Attenuator					RT Tuned?	RCV ONLY Position	Squelch [Para 4-5a(5)]	Retransmit [Para 4-5a(6)]
	TUNE Position	RCV ONLY Position				SINAD > 10 dB	Level		Distortion	Level				Key
1	2.150	AM	2.150	X ②	110	X		X	X	X	X	X	X	X
2	2.150	SSB	2.151	X	20	X		X	X	X	X	X	X	X
3	2.150	FM	2.150	X	20	X		X	X	X	X	X	X	X
4 ③	2.150	AM	2.150	X	200,000	X		X	X	X	X	X	X	X
5	2.150	AM	2.150	X	100,000 ④	X	X		X	X	X	X	X	X
6	2.150	AM	2.150	X	3,500	X	X	X			X	X	X	X
7	2.150	SSB	2.151	X	3,500	X	X	X			X	X	X	X
8	2.150	FM	2.150	X	3,500	X	X	X			X	X	X	X
9	2.150	AM	2.150	X	3,500	X	X	X	X	X		X	X	X
10 ⑤	2.150	AM	2.150	X	3,500	X	X	X	X	X	X			X
11	2.150	FM	2.150	X	3,500	X	X	X	X	X	X	X	X	
12	2.150	FSK	2.151	20	20	18	18							
13	2.150	CW	2.151	20	20	Same	—							
14	5.100	SSB	5.101	0	20	19	19							
15	8.400	SSB	8.401	0	20	19	19							
16	12.500	SSB	12.501	0	20	18	19							
17	17.322	SSB	17.323	0	20	17.5	16							
18	25.122	SSB	25.123	0	20	15	14							
19	35.055	FM	35.055	40	40	24	24							
20	40.055	FM	40.055	40	40	24	23							
21	50.222	FM	50.222	40	40	24	24							
22	60.122	FM	60.122	40	40	24	24							
23	75.122	FM	75.122	X	50	X	23							
24														

NOTES

(X in any column means "do not perform this test")

① Sig. Gen. Modulation

AM: 30% at 1 kHz

FM: 8 kHz Deviation (5 kHz deviation for Test No. 11)

Others: CW

② Do not tune (TUNE position), or disregard.

③ Perform only if test nos. 1, 2, and 3 all fail.

④ Level into antenna connector for this test only.

⑤ Retransmit load equals 1 kilohm selectable on Isolation Box, all other tests are 500 ohm load.

Tested by _____

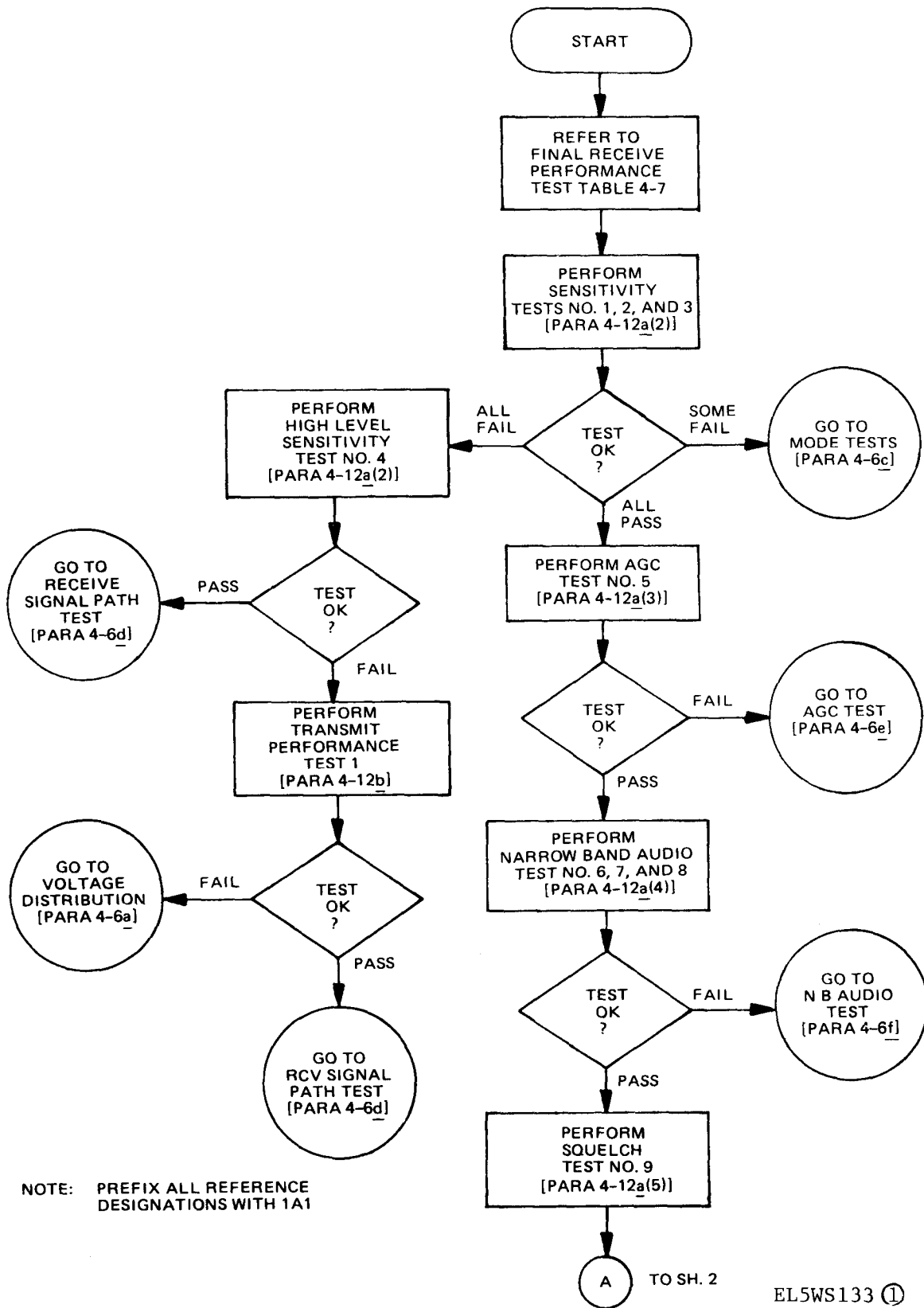
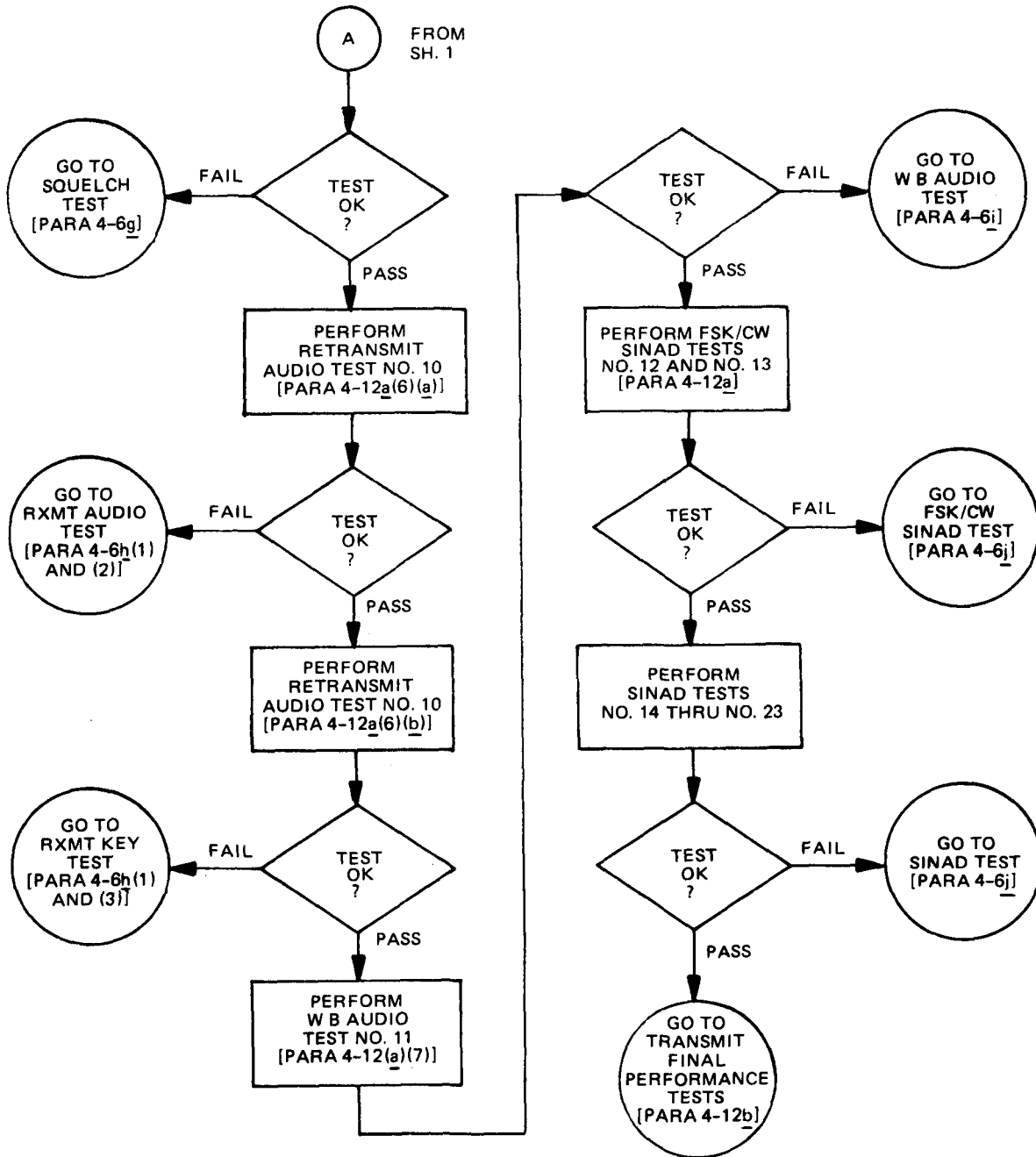

Figure 4-93. Final receive performance test diagram (sheet 1 of 2).



NOTE: PREFIX ALL REFERENCE DESIGNATIONS WITH 1A1

EL5WS133 (2)

Figure 4-93. Final receive performance test diagram (sheet 2 of 2).

(a) Set RT and signal generator controls and switches to positions given in table 4-7 for test No. 1.

(b) Adjust RT VOLUME control for 1.5 \pm 0.5 V rms as measured on distortion analyzer.

(c) Set distortion analyzer control to SET LEVEL and adjust SET LEVEL control for zero dB reference.

(d) Set distortion analyzer control to DISTORTION and null 1 kHz signal with distortion analyzer frequency control.

(e) SINAD is difference in dB between steps (c) and (d) above.

(f) An acceptable SINAD limit is 10 dB or more. Record P (Pass) or F (Fail).

2. Repeat step 1 above for test No. 2 and 3.

3. If test No. 1, 2 and 3 all pass, go to AGC Test paragraph 4-12a(3) below. If tests No. 1, 2 and 3 all fail, go to High Level Sensitivity Test paragraph 4-6c.

(c) High level sensitivity test (No. 4)

1. Set RT and signal generator controls and switches to positions given in table 4-7 test No. 4.

2. Perform Low Level Sensitivity Test (No. 1, 2, and 3) to check SINAD for test No. 4. Record P (Pass) or F (Fail).

(3) AGC test (No. 5).

(a) AGC test setup.

CAUTION

Do not tune the RT or key the handset PTT switch when the signal generator is connected directly to the ANT connector.

1. Setup equipment as discussed in paragraph 4-12a(1) and shown in figure 4-92 except for the step attenuator. Connect the signal generator directly to the RT ANT connector for this test only.

2. Set RT SQUELCH switch to OFF.

(b) AGC test.

1. Set RT and signal generator controls and switches to positions given in table 4-7 test No. 5.

2. Adjust RT VOLUME control for an audio output level of 1.5 \pm 0.5 V rms as measured on distortion analyzer.

3. Check to see that distortion level is less than 10 percent. Record P (Pass) or F (Fail).

(4) Narrow band audio test (No. 6, 7, and 8).

(a) Narrow band audio test setup.

1. Setup equipment as discussed in paragraph 4-12a(1) and shown in figure 4-92.

2. Set RT SQUELCH switch to OFF.

(b) Narrow band audio test.

1. Set RT and signal generator controls

and switches to positions given in table 4-7 test No. 6.

2. Set distortion analyzer to VOLT-METER function and METER RANGE switch to 3 volts.

3. Check to see that audio output level is more than 2.3 V rms measured on distortion analyzer. Record P (Pass) and F (Fail).

4. Adjust RT VOLUME control for an audio output level of 2.2 V rms measured on distortion analyzer.

5. Check to see that audio distortion is less than 10 percent. Record P (Pass) or F (Fail).

6. Set RT and Signal Generator controls and switches to positions given in table 4-7 test No. 7.

7. Check to see that audio output level is more than 2.3 V rms measured on distortion analyzer. Record P (Pass) or F (Fail).

8. Adjust RT VOLUME control for an audio output level of 2.2 V rms measured on distortion analyzer.

9. Check to see that audio distortion is less than 10 percent. Record P (Pass) or F (Fail).

10. Set RT and signal generator controls and switches to positions given in table 4-7 test No. 8.

11. Check to see that audio output level is more than 2.3 V rms measured on distortion analyzer. Record P (Pass) or F (Fail).

12. Adjust RT VOLUME control for an audio output level of 2.2 V rms measured on distortion analyzer.

13. Check to see that audio distortion is less than 10 percent. Record P (Pass) or F (Fail).

(5) Squelch test (No. 9).

(a) Squelch test setup.

1. Setup equipment as discussed in paragraph 4-12a(1) and shown in figure 4-92.

2. Set RT POWER switch to RCV ONLY.

3. Set RT SQUELCH switch to OFF.

(b) Squelch test.

1. Set RT and signal generator controls and switches to position given in table 4-7 test No. 9. (For this test only, set signal generator to 30 percent AM modulation at 500 Hz.)

2. Adjust audio output level to 1.5 V rms as measured on distortion analyzer.

3. Set RT SQUELCH switch to ON.

4. Check to see that audio output level remains at 1.5 V rms as in step 2 above. Record P (Pass) or F (Fail).

5. Disconnect RF Signal Generator input to RT. Audio output level should drop by at least 20 dB. Record P (Pass) or F (Fail).

(6) Retransmit test (No. 10).

(a) Retransmit test setup.

1. Setup equipment as discussed in paragraph 4-12a(1) and shown in figure 4-92.

2. Set switch S2 on Isolation Box to the 1000 ohms position.

3. Set RT SQUELCH switch to RXMT.

4. Set RT POWER switch to RCV ONLY.

5. Set RT VOLUME control to midrange.

6. Set RT and signal generator controls and switches to positions given in table 4-7 test No. 10. (For this test only, set signal generator to 30 percent AM modulation at 500 Hz modulating frequency.)

(b) *Retransmit level test.*

1. Check to see that audio output level is more than 150 mV rms measured on distortion analyzer. Record P (Pass) or F (Fail).

2. Set RT VOLUME control to minimum (fully CCW).

3. Check to see that audio output level is same as in step 1 above. Record P (Pass) or F (Fail).

(c) *Retransmit key test.*

1. Set signal generator to AM modulation at 30 percent and 500 Hz.

2. Set output level of signal generator to 3500 mV.

3. Check to see that resistance between Isolation Box J5 and J6 is less than 50 ohms using multimeter. Record P (Pass) or F (Fail).

4. Disconnect signal generator.

5. Measure resistance between Isolation Box J5 and J6. Resistance shall be greater than 10 kilohms. Record P (Pass) or F (Fail).

(7) *Wide band x-mode audio response test (No. 11).*

(a) *Wide band audio response test setup.*

1. Setup equipment as discussed in paragraph 4-12a(1) and shown in figure 4-92.

2. Connect distortion analyzer to X-Mode test box connector J2.

3. Set RT SQUELCH switch to OFF.

(b) *Wide band audio response test.*

1. Set RT and signal generator controls and switches to positions given in table 4-7 test No. 11. FM deviation is set at 5 kHz on signal generator.

2. Check to see that audio output level at X-mode connector J2 is more than 250 mV rms measured on distortion analyzer. Record P (Pass) or F (Fail).

3. Set signal generator modulation frequency to 20 Hz.

4. Check to see that audio output level is within 2.5 dB from level of step 2 above. Record P (Pass) or F (Fail).

5. Set signal generator modulation frequency to 8 kHz.

6. Check to see that audio output level is within 0 to -5 dB from level of step 2 above. Record P (Pass) or F (Fail).

(8) *FSK/CW sensitivity tests (No. 12 and 13).*

(a) *FSK/CW sensitivity test setup.*

1. Setup equipment as discussed in paragraph 4-12a(1) and shown in figure 4-92.

2. Set RT SQUELCH switch to OFF.

(b) *FSK/CW sensitivity test.*

NOTE

The POWER switch is spring-loaded in the TUNE position and automatically returns to the HI PWR position when released.

1. Set RT and signal generator controls and switches to positions given in table 4-7 test No. 12.

2. Tune RT. If RT will not tune, set RT POWER control selector to RCV ONLY.

3. Perform low level sensitivity test (No. 1) to check SINAD for test No. 12. Record P (Pass) or F (Fail).

4. Set RF and signal generator controls and switches to positions given in table 4-7 test No. 13.

5. Perform steps as in 2 and 3 above to check SINAD for test No. 13. Record P (Pass) or F (Fail).

(9) *SSB sensitivity tests (No. 14 through No. 18).*

(a) *SSB sensitivity test setup.*

1. Setup equipment as discussed in paragraph 4-12a(1) and shown in figure 4-92.

2. Set RT SQUELCH switch to OFF.

(b) *SSB sensitivity tests.*

NOTE

The POWER switch is spring-loaded in the TUNE position and automatically returns to HI PWR position when released.

1. Set RT and signal generator controls and switches to positions given in table 4-7 for test No. 14.

2. Tune RT. If RT unit will not tune set RT POWER controls selector to RCV ONLY.

3. Perform low level sensitivity tests (No. 1) to check SINAD for test no. 14. Record P (Pass) or F (Fail).

4. Repeat steps 1, 2, and 3 above to check SINAD for tests No. 15 through 18. Record P (Pass) or F (Fail) for each test.

(10) *FM sensitivity tests (No. 19 through No. 23).*

NOTE

For test No. 23 use only untuned RCV ONLY position of RT POWER selector.

(a) *FM sensitivity test setup.*

1. Setup equipment as discussed in paragraph 4-12a(1) and shown in figure 4-92.

2. Set RT SQUELCH switch to OFF.

(b) *FM sensitivity tests.*

NOTE

The POWER switch is spring-loaded in the TUNE position and automatically returns to HI PWR position when released.

1. Set RT and signal generator controls and switches to positions given in table 4-7 for test No. 19.

2. Tune RT. If RT unit will not tune, set RT POWER control selector to RCV ONLY.

3. Perform low level sensitivity tests (No. 1) to check SINAD for test No. 19. Record P (Pass) or F (Fail).

4. Repeat steps 1, 2, and 3 above to check SINAD for tests No. 20 through 23. Record P (Pass) or F (Fail) for each test.

b. *Final Transmit Performance Tests.* If Receive Tests have all passed, proceed with final transmit performance tests. After receive and transmit performance tests have passed, the RT may be returned to service. If transmit performance tests fail, follow troubleshooting procedures given in the text and diagrams for the next action to be taken. See figure 4-95. After performing troubleshooting and final tests if RT will not pass a second time, send RT to higher level maintenance.

(1) *Final transmit performance test setup.*

(a) Inspect RT for external defects or damage (see chap 2).

(b) Check to see that POWER and SQUELCH switches on RT are OFF.

CAUTION

Be sure polarity is correct when connecting the power supply to the radio.

(c) Connect RT and test equipment as shown in figure 4-94.

(d) Turn on test equipment and allow at least 30 minutes warmup.

(e) Prepare transmit performance data sheets similar to table 4-8 for use during transmit performance testing. Do not write in this book.

(f) As each test is completed, one or more questions about that test must be answered by insertion of P (Pass) or F (Fail) on the data sheet.

(g) The next procedure is to determine the action required from the answer(s) to questions of (f) above.

(h) Do not begin troubleshooting procedures until directed to do so in text or figure during performance testing. If a particular trouble is indicated during the tests, and further direction is not given, it must be noted along with test data for later evaluation.

(i) Follow directions to and from additional flow diagrams and/or instructions in the text during all testing.

(j) Figure 4-95 shows the path followed during final transmit performance testing.

(2) *AM and SSB output test (No. 1 and 2).*

(a) *AM power output test (No. 1).*

1. Set RT controls as follows:

<i>Control</i>	<i>Setting</i>
POWER	RCV ONLY
MODE	AM
FREQUENCY	2.1500 MHz
VOLUME	Midrange

2. Adjust audio oscillator No. 1 for a frequency of 1.5 kHz and level out of Isolation Box of 2 mV measured on the distortion analyzer.

3. Place RT into coupler Home position.

NOTE

Coupler Home is attained by setting RT POWER control from RCV ONLY to a power position without tuning. If coupler Home test fails during any of tests in table 4-8, replace 1A1A24 and repeat test.

4. Key RT in LO PWR. Check to see that output voltage is 7 to 16 V ac as measured on multimeter and current is less than 2.5 amperes as measured on power supply meter. Unkey RT.

5. Set RT POWER control to HI PWR. Key RT and check to see that output voltage is between 30 and 50 V ac and current is less than 7 amperes. Unkey RT.

6. If power output fails, go to transmit signal path troubleshooting test paragraph 4-7a.

7. If power output passes, proceed to test No. 2.

(b) *SSB distortion test (No. 2).*

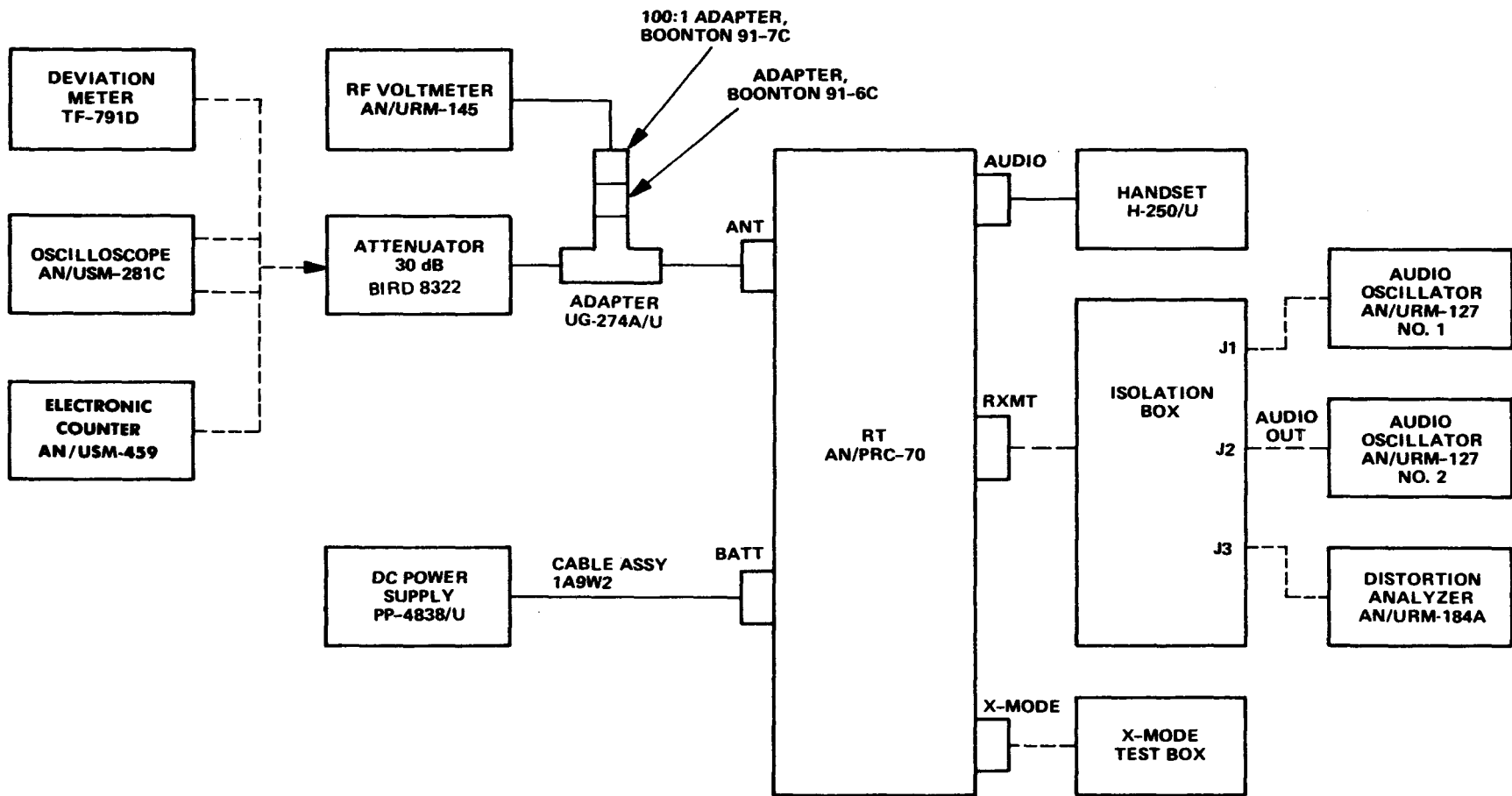

EL5WS134

Figure 4-94. Final transmit performance test setup.

Table 4-8. Final Transmit Performance Tests

Test	Mode	Radio Frequency (MHz)	Coupler Status			Power						Modulation			
						LO		HI		Sidetone					
			Home	Tune	No-Tune Tone Present	E _{out}	I _{in}	E _{out}	I _{in}	LO	HI	% AM	Deviation FM	Distortion SSB	CW/FSK
1	AM	2.150		X	X					X	X	X	X	X	X
2	SSB	2.150		X	X					X	X	X	X		X
3	AM	2.150		X	X	X	X	X	X	X	X		X	X	X
4	SSB	2.150		X	X	X	X	X	X		X	X	X	X	X
5	AM	2.150		X		X	X	X	X	X	X	X	X	X	X
6	CW	2.150		X		X	X			X	X	X	X	X	
7	FSK	2.150		X		X	X			X	X	X	X	X	
8	SSB	3.900	X			X	X			X		X	X	X	X
9	SSB	5.100	X			X	X			X		X	X	X	X
10	SSB	8.400	X			X	X			X		X	X	X	X
11	SSB	12.550	X			X	X			X		X	X	X	X
12	SSB	17.322	X			X	X			X		X	X	X	X
13	SSB	25.122	X			X	X			X		X	X	X	X
14	SSB	35.055	X			X	X			X		X	X	X	X
15	FM	35.055	X			X	X				X	X	NB	X	X
16	FM	35.055	X			X	X	X	X	X	X	X	WB	X	X
17	FM	40.055	X			X	X			X		X	X	X	X
18	FM	50.222	X			X	X			X		X	X	X	X
19	FM	60.122	X			X	X			X		X	X	X	X
Spare															

- Note:
- X in any column means disregard.
 - Denote by P (Pass) or F (Fail) as tests are completed.
 - If No-Tune tone is heard in headset (2 kHz tone @ 2-3 Hz rate) during any power output measurement, coupler test failed.
 - Coupler Home — Obtained by setting POWER control to RCV ONLY and then to power shown, without tuning.

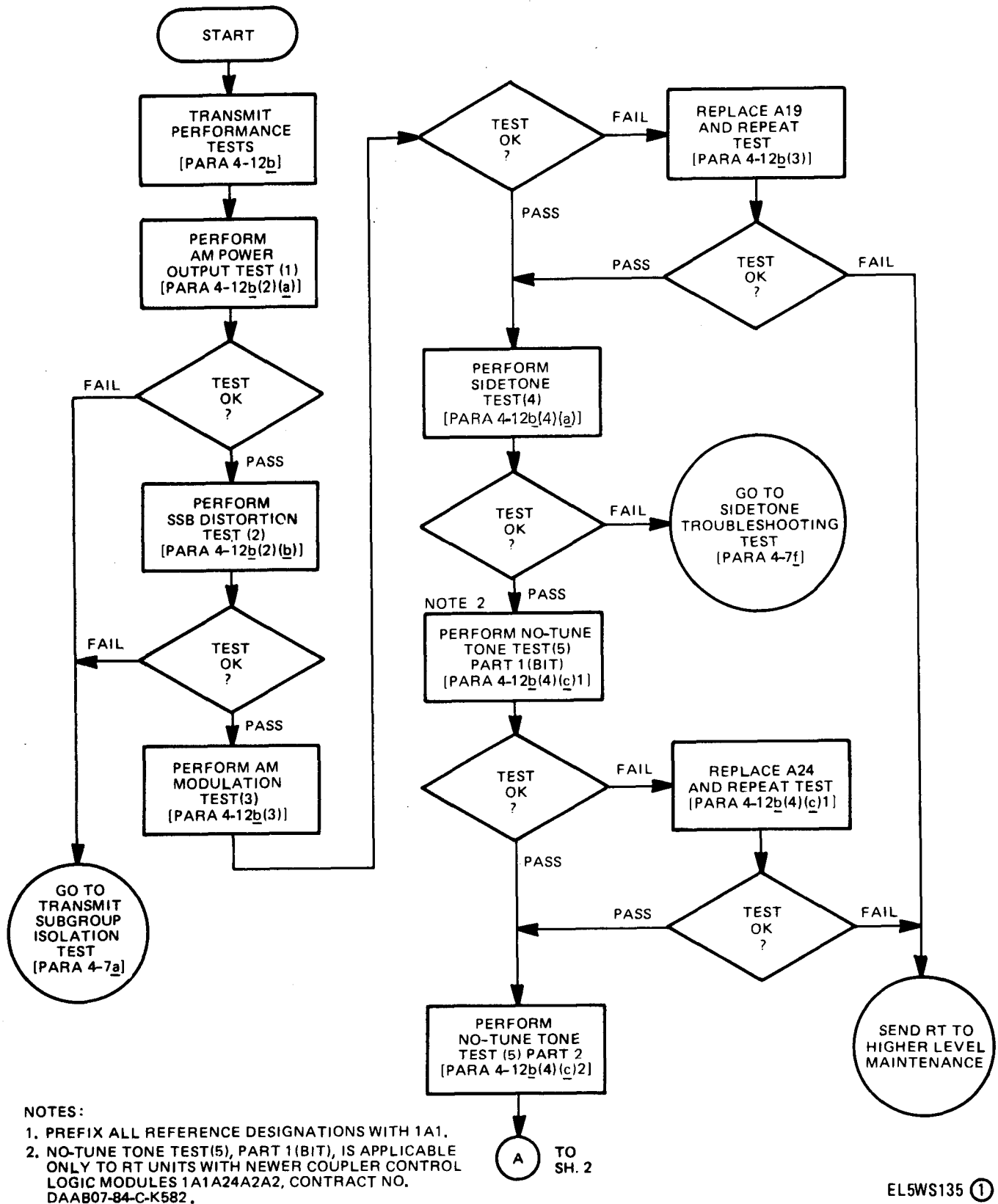
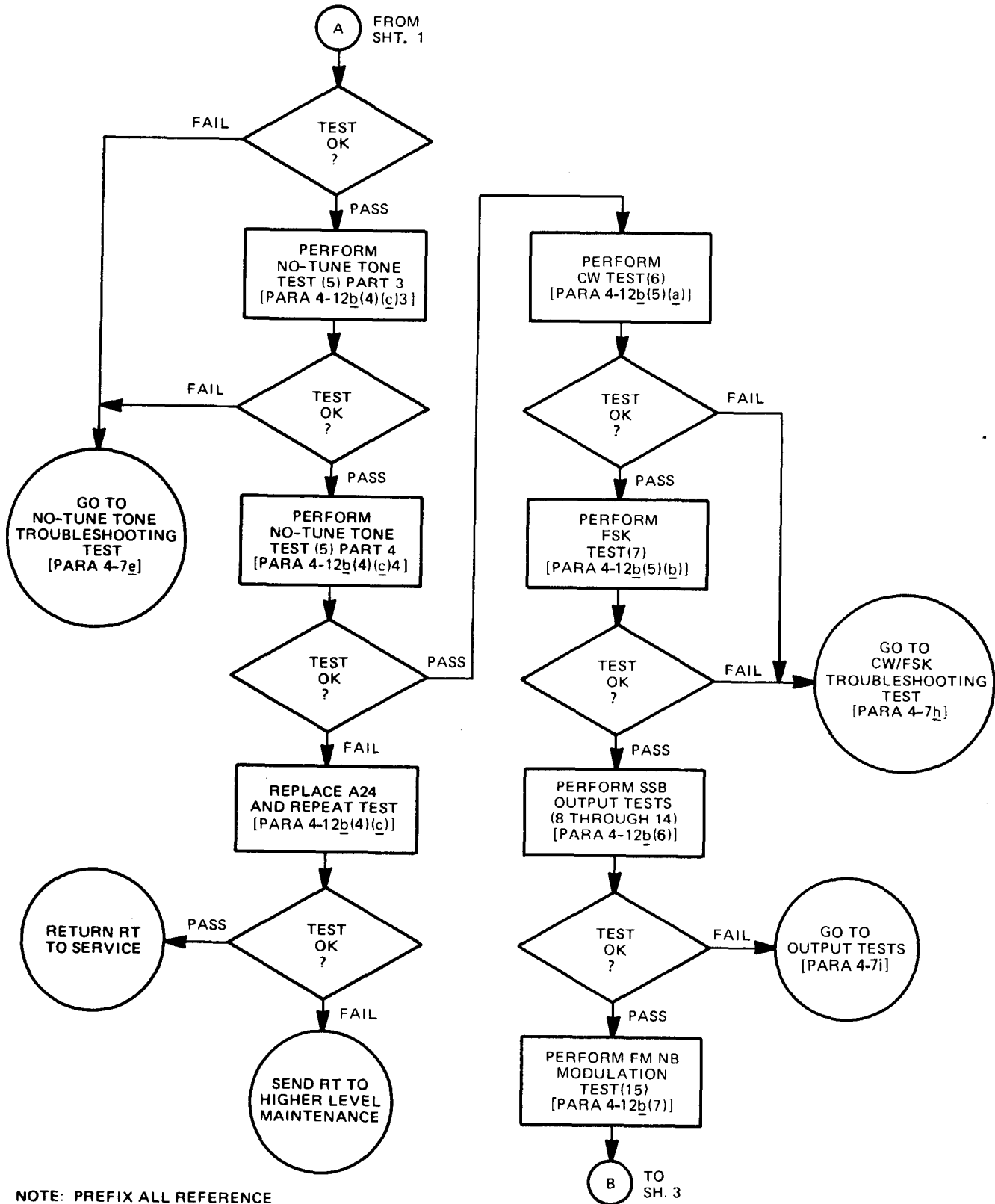

Figure 4-95. Final Transmit performance flow diagram (sheet 1 of 3).



NOTE: PREFIX ALL REFERENCE DESIGNATIONS WITH 1A1

EL5WS135 ②

Figure 4-95. Final Transmit performance flow diagram (sheet 2 of 3).

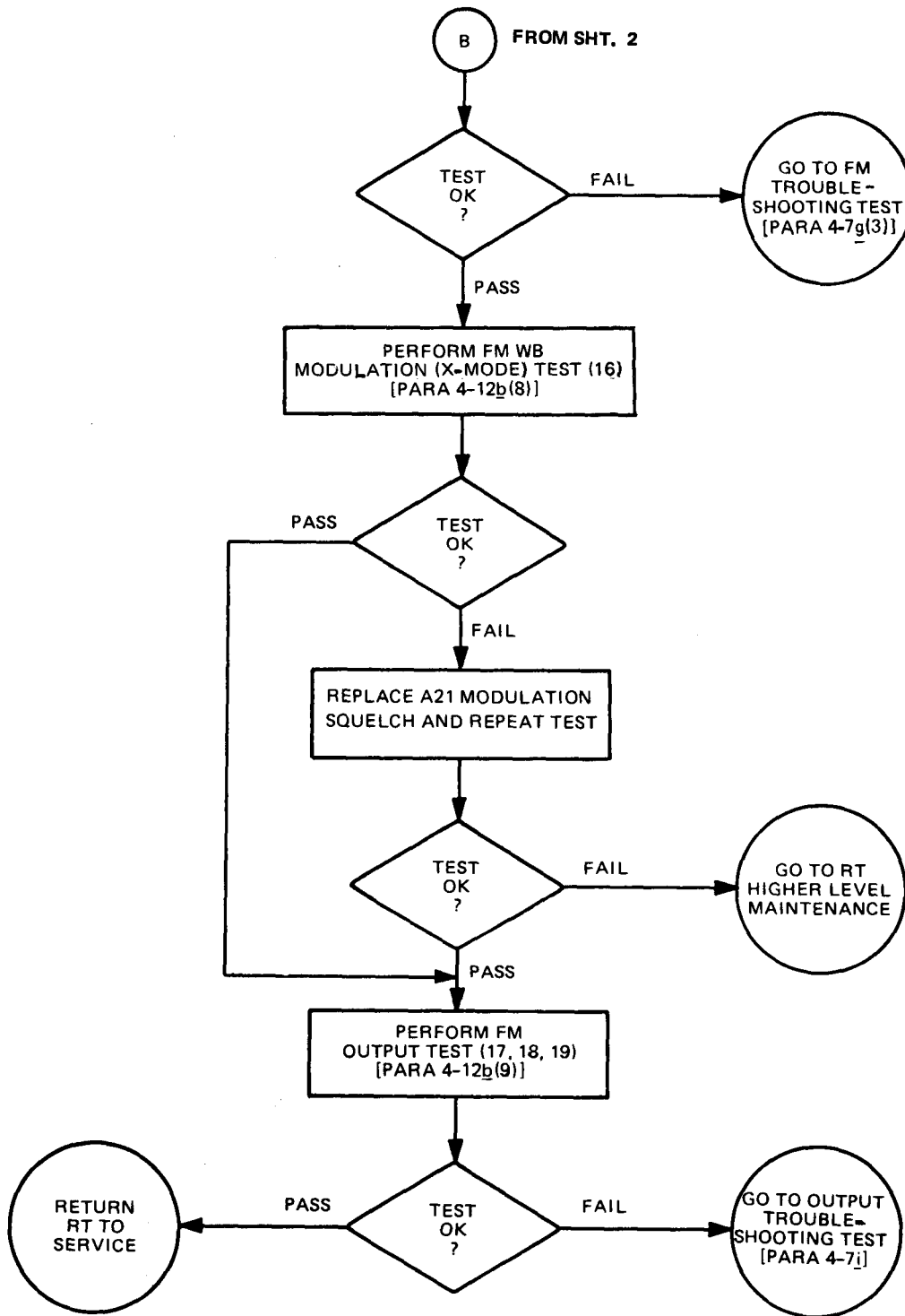

NOTE: PREFIX ALL REFERENCE DESIGNATIONS WITH 1A1

EL5WS135 ③

Figure 4-95. Final Transmit performance flow diagram (sheet 3 of 3).

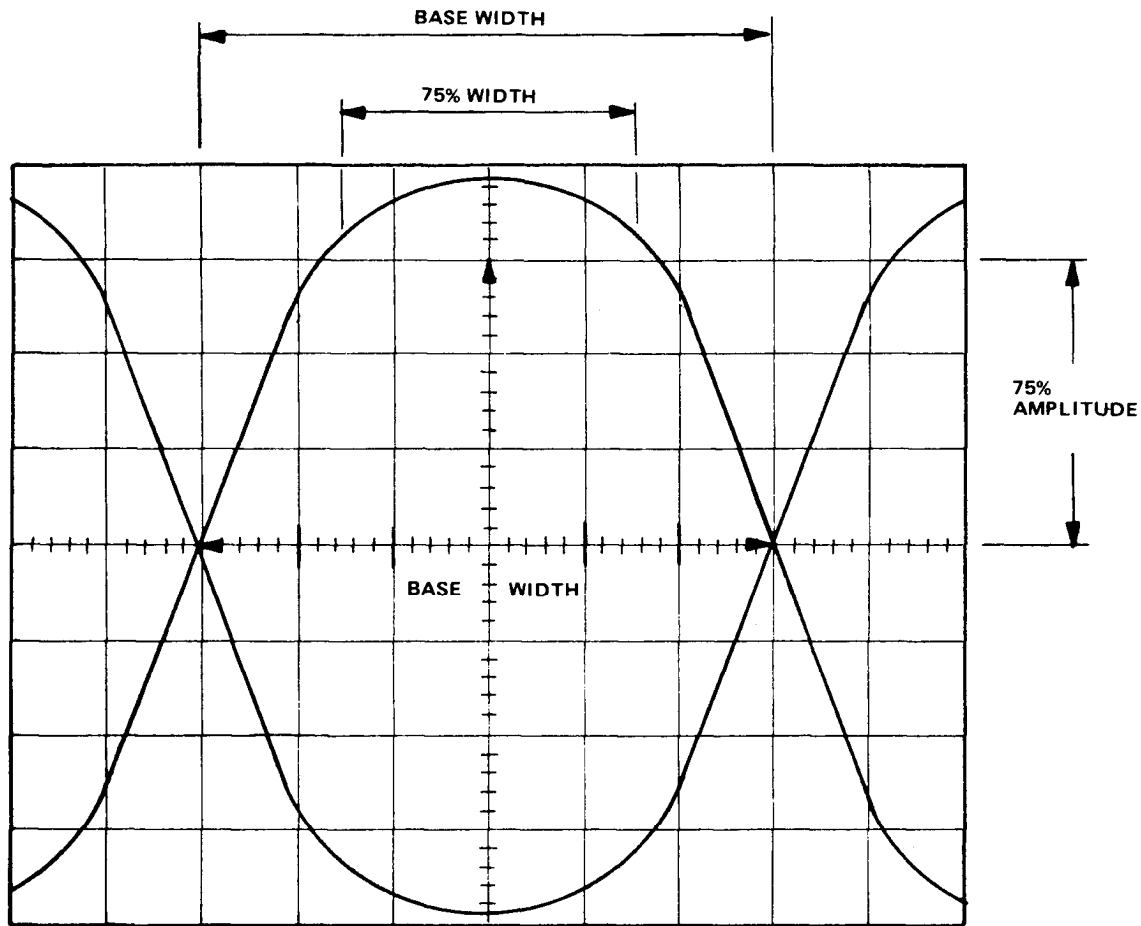

THE RATIO OF THE WIDTH AT 75% AMPLITUDE TO THE BASE WIDTH MUST BE LESS THAN 0.7.

EL5WS047

Figure 4-96. Single side band distortion waveform.

1. Set RT controls as follows:

<i>Control</i>	<i>Setting</i>
POWER	RCV ONLY
MODE	SSB
FREQUENCY	2.1500 MHz
VOLUME	Midrange

2. Disconnect audio oscillator No. 1. Connect audio oscillator No. 2 and adjust for 2.8 kHz at a level of 2 mV out of Isolation Box.

3. Reconnect audio oscillator No. 1.

4. Place RT into coupler Home position by setting POWER control to LO PWR.

5. Key RT and check to see that output voltage is more than 7 V ac and current is less than 2.5 amperes. Unkey RT.

6. Set RT POWER control to HI PWR. Key RT and check to see that output voltage is between 32 and 50 V ac and current is less than 5.5 amperes, Unkey RT.

7. Connect oscilloscope to the output of the 30 dB attenuator.

8. Key RT.

9. Adjust oscilloscope for a waveform base width of 4 to 6 divisions.

10. Check to see that waveform width at 75 percent amplitude is less than 70 percent of width, at base. Figure 4-96 shows this waveform.

11. Unkey RT.

12. If test passes proceed to AM modulation test No. 3.

13. If test fails go to transmit signal path troubleshooting tests paragraph 4-7a.

(3) AM modulation test (no. 3).

(a) Set RT POWER control to RCV ONLY, MODE to AM, and FREQUENCY to 2.150 MHz.

(b) Set audio oscillator to 1 kHz at a level out of Isolation Box of 2 mV.

(c) Place RT in coupler Home position.

(d) Connect oscilloscope to rear of 30 dB Attenuator.

(e) Key RT. Check to see that ratio of maximum voltage to minimum voltage is more than 3 to 1. Figure 4-97 shows this waveform.

(f) Unkey RT.

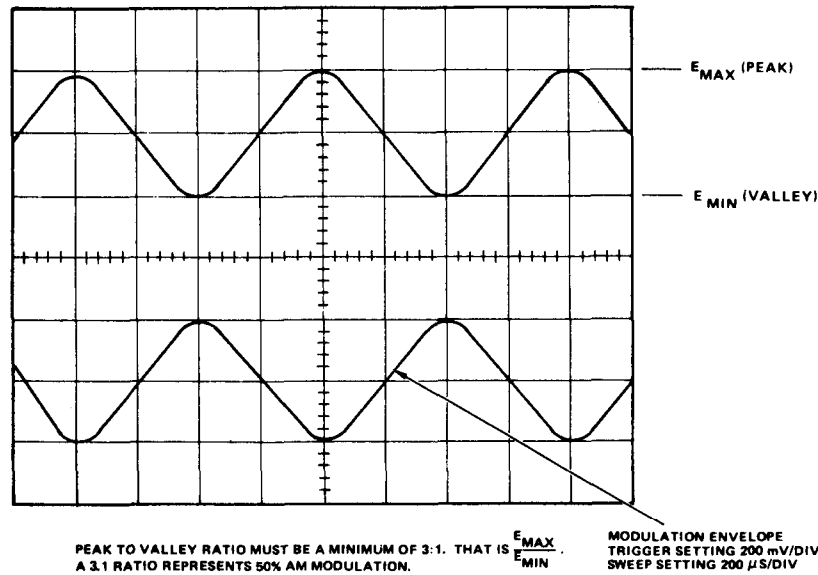

Figure 4-97. AM modulation waveform.

(4) Sidetone/No-Tune tone test (No. 4 and 5).

(a) Test setup.

1. Set RT controls as follows:

Control	Setting
POWER	RCV ONLY
MODE	SSB
FREQUENCY	2.150 MHz

2. Set audio oscillator No. 1 to 2 kHz and adjust for an output level of 2 mV out of Isolation Box.

3. Disconnect audio oscillator No. 2.

4. Set RT POWER control to LO PWR.

(b) Sidetone test (No. 4).

1. Part 1.

(a) Key RT. A sidetone should be heard in handset.

(b) Unkey RT.

(c) If test fails, go to troubleshooting test, paragraph 4-7f(3)(a).

2. Part 2.

(a) Adjust audio oscillator No. 1 to 5 kHz while RT remains keyed.

(b) A sidetone should be heard. Check that output voltage is less than 4 VAC as measured on rf voltmeter.

(c) After approximately 10 seconds, sidetone should not be heard.

(d) Unkey RT.

(e) If test fails, go to troubleshooting test, paragraph 4-7f(3)(c).

(c) No-Tune tone test (No. 5).

NOTE

Part 1 is applicable only to RT units with newer coupler control logic modules 1A1A24A2A2 (in coupler 1A1A24), Contract No. DAAB07-84-C-K582.

1. Part 1 (Built-in-Test) (BIT).

(a) Set RT controls as follows:

Control	Setting
POWER	OFF
MODE	AM
FREQUENCY	2.150 MHz

hold (b) Set RT POWER switch to TUNE and

should not be heard.

(d) Release RT POWER switch.

(e) If No-Tune tone is heard, replace 1A1A24 and repeat test steps (a) through (d).

(f) If No-Tune tone is not heard, proceed to part 2 test.

2. Part 2.

(a) Set RT POWER control to RCV ONLY (coupler home position), and then to LO PWR.

(b) Key RT and listen in handset for a No-Tune tone (a 2 kHz tone burst at 2.4 Hz rate). A No-Tune tone should not be heard.

(c) Unkey RT.

3. Part 3.

(a) Open antenna lead by removing coax from RT antenna

(b) Set RT POWER switch to RCV and then Lo PWR.

(c) Key RT.

NOTE

Two key operations may be required.

(d) Listen in handset for No-Tune tone. The No-Tune tone should be heard.

(e) Unkey RT.

4. Part 4.

(a) Reconnect 50 ohm RF cable with 30 dB Attenuator to ANT connector.

(b) Set RT POWER switch to TUNE position and release.

(c) After tuning is complete, set RT POWER switch to LO PWR.

(d) Key RT. Listen for No-Tune tone.

(e) Unkey RT.

(f) If No-Tune tone is heard, replace 1A1A24 and repeat test step (b) through (e) above.

(g) If No-Tune tone is not heard, proceed to Test No. 6 of table 4-8, paragraph (5).

(5) *CW/FSK modulation test (No. 6 and 7).*

(a) *CW test (No. 6).*

1. Connect frequency counter to 30 dB attenuator and set resolution to 10 Hz. Disconnect both audio oscillators.

2. Set RT MODE to CW and POWER control to HI PWR.

3. Key RT. Check to see that output frequency is 2.1520 MHz \pm 200 Hz.

4. Check to see that output voltage is between 32 and 50 V ac and current is less than 7 amperes.

5. Unkey RT.

6. If test passes, continue with FSK test, paragraph (b).

7. If test fails, go to troubleshooting test, paragraph 4-7 h

(b) *FSK test (No. 7).*

1. Connect frequency counter to 30 dB attenuator. Set RT MODE to FSK, and POWER control selector to HI PWR.

2. Key RT and check to see that output frequency is 2.1516 MHz \pm 200 Hz.

3. Unkey RT. Check to see that immediately after unkeying, the output frequency momentarily indicates 2.1524 MHz \pm 200 Hz.

4. If test passes, continue with SSB output tests (No. 8 through 14), paragraph (6).

5. If test fails, go to troubleshooting test, paragraph 4-7 h

(6) *SSB output tests (No. 8 through 14).*

(a) *Test setup*

1. Connect both audio oscillators to the Isolation Box.

2. Adjust audio oscillator No. 1 to 1500 Hz at 2 mV output.

3. Set RT MODE control to SSB.

4. Set RT POWER control to HI PWR.

(b) *Test No. 8*

1. Set RT FREQUENCY to 3.900 MHz.

2. Tune RT.

3. Key RT.

4. Check to see that output voltage is between 28 and 49 V ac and current is less than 7 amperes.

5. unkey RT.

6. If test passes, continue with tests No. 9 through 14, paragraph (c).

7. If voltage and current are not within limits, go to troubleshooting test, paragraph 4-7 i.

(c) *Tests No. 9 through 14.* Repeat test procedures of test No. 8 for tests No. 9 through 14 at the respective frequency given in table 4-8.

(7) *FM modulation test (No. 15).*

(a) *Test setup.*

1. Disconnect audio oscillator No. 2 and set audio oscillator No. 1 for a frequency of 1 kHz with Isolation Box output of 2 mV \pm 0.3 mV.

2. Connect multimeter to rear of 30 dB attenuator.

3. Set RT POWER control to HI PWR and MODE control to FM, and FREQUENCY to 35.055 MHz.

4. Tune RT.

(b) *Output test.*

1. Key RT.

2. Check to see that output voltage is between 28 and 49 V ac and current is less than 7 amperes.

3. Unkey RT.

4. If test passes, continue with modulation test of composite, paragraph (c).

5. If voltage and current are not within limits, go to troubleshooting test, paragraph 4-7 i.

(c) *Modulation test of composite.*

1. Connect deviation meter to rear of 30 dB attenuator.

2. Set RT POWER control to LO PWR.

3. Key RT. Check to see that modulation is is between 8 kHz and 13 kHz.

(d) *150 Hz test.*

1. Disconnect audio oscillator.

2. Key RT.

3. Check to see that 150 Hz signal is between 2.4 kHz and 4.0 kHz on deviation meter.

4. Unkey RT.

5. If test passes, continue with wideband X-mode test No. 16, paragraph (8).

6. If test fails, go to troubleshooting test, paragraph 4-7 g.

(8) *Wide band X-mode test No. 16.*

(a) *Test setup.*

1. Connect audio oscillator No. 1 output to X-Mode Test Box and oscilloscope.

2. Set audio oscillator frequency to 1000 Hz.

3. Adjust output level to 12 V p-p on oscilloscope.

4. Set RT POWER control to LO PWR.

5. Set MODE control to FM.

6. Set FREQUENCY to 35.055 MHz.

(b) *Wide band deviation test.*

1. Tune RT.

2. Key RT.

3. Measure FM deviation.

4. Test passes if peak deviation is between 3 and 7 kHz.

5. Unkey RT.

(9) *FM output tests (No. 17, 18 and 19).*

(a) *Test setup.*

1. Reconnect audio oscillator No. 1 to Isolation Box.

2. Adjust audio oscillator No. 1 level to 2 mV into RT.

3. Set RT MODE control to FM.

(b) *Test No. 17.*

1. Set RT FREQUENCY to 30.055 MHz.

2. Tune RT.

3. Key RT.

4. Check to see that output voltage is 28 to 49 V ac and current is less than 7 amperes.

5. Unkey RT.

6. If test passes, continue with test No. 18 and 19, paragraph (c).

7. If test fails, go to troubleshooting test, paragraph 4-7 *i*.

(c) *Test No. 18 and 19.*

1. Repeat test procedures of test No. 17 for tests No. 18 and 19 at the respective frequency.

2. If test No. 19 passes and all previous tests pass, return RT to service.

4-13. Performance Standards

Table 4-9 provides a listing of performance standards that must be attained before the RT unit can be considered to be operating properly. If these standards are not reached, refer to paragraph 4-9 for troubleshooting procedures.

Table 4-9. Minimum Performance Standards

Function	Minimum performance standard
Receive: AM	10 dB minimum (para 4-12a(2))
SSB	10 dB minimum (para 4-12a(2))
FSK	10 dB minimum (para 4-12a(8))
CW	10 dB minimum (para 4-12a(8))
FM	10 dB minimum (para 4-12a(2))
AGC	Audio level is more than 1000 mV and less than 10% distortion (para 4-12a(3))
Squelch	Operates properly (para 4-12b(5))
Transmit: AM	LO PWR: 7 to 16 V ac, <2.5A (para 4-12b(2)) HI PWR: 30 to 50 V ac, <7A (para 4-12b(2))
CW	HI PWR: 32 to 50 V ac, <7A (para 4-12b(5))
FSK	HI PWR: Output frequency momentarily increases 8 kHz immediately after unkeying (para 4-12b(5))
SSB	LO PWR: >7 V ac, <2.5 A (para 4-12b(2)) HI PWR: 32 to 50 V ac, <5.5A (para 4-12b(2)), 28 to 49 V ac, <7A (para 4-12b(6))
FM (30 to 76 MHz)	HI PWR: 28 to 49 V ac, >7A (para 4-12b(7), (9))
AM modulation	Greater than 50% (para 4-12b(3))
FM modulation	8 to 13 kHz (para 4-12b(7)), 3 to 7 kHz (para 4-12b(8))
Retransmit: Audio Resistance	150 mV (para 4-12a(6)) <50 ohm with signal input (para 4-12a(6)) > 10K without signal input (para 4-12a(6))

4-13.1. Frequency Stability Test for AN/PRC-70 at DS Level (fig. 4-98)

NOTE

Before performing this test, allow the de-energized radio to temperature stabilize for at least 2 hours with the top cover removed. (See ch 4, sec IV, para 4-10a(1) of TM 11-5820-553-23 for disassembly instructions).

a. This test is to be performed at a temperature not less than 18°C (65°F) nor more than 28°C (82°F).

b. Turn on Frequency Counter AN/USM-459 and ensure it has been warmed up at least 20 minutes before use.

c. Ensure Radio Set AN/PRC-70 is off prior to connecting power supply.

d. Connect the AN/PRC-70 to the power supply (HR40-7.5B, PP-4838/U), using maintenance cable NSN 5995-01-092-5943.

e. Connect coaxial cable with attenuator from the antenna coaxial connection of the AN/PRC-70, to Frequency Counter AN/USM-459 Channel A input (fig. 4-98).

f. Set the frequency selector of the AN/PRC-70 to 45000.00 KHz.

g. Set Frequency Counter AN/USM-459 as follows:

- (A) Function Switch: Freq A.
- (B) Frequency Resolution Switch: 1 Hz, 10°.
- (C) Sample Rate Knob: Fully counterclockwise.
- (D) Level A Control: Adjust until trigger light blinks.
- (E) Input Coupler: AC.
- (F) Slope: Either + or -.
- (G) Initially set the Channel A attenuation to x100 position. Reduce if necessary for proper operation.

CAUTION

Check all connections and dial settings at this time.

h. Turn on power supply and adjust voltage to 24 ±0.5 VDC.

i. Turn on the AN/PRC-70 and perform coupler tune, coupler tune is complete when 2 KHz beep ceases.

j. Upon completion of coupler tune, set output power to LO POWER.

k. Set the AN/PRC-70 mode switch to AM.

CAUTION

Check again to be sure output power is set to LO POWER.

l. Do not proceed until the AN/USM-459 has warmed up for at least 20 minutes.

m. Key the transmitter for at least 5 seconds and measure the carrier frequency on the counter.

n. If the frequency is within the range of 44999.982 KHz to 45000.018 KHz (45000.000 KHz ±18 Hz), the AN/PRC-70 is operational and can be returned to the field after replacing the top cover. (See TM 11-5820-553-23, ch 4, sec IV, para 4-10a(2).)

o. If the frequency is not within the above limits (n above) the oscillator digital divider module 1A1A11 should be removed and returned to depot for calibration. (See ch 4, Sec IV, para 4-10b(3) of TM 11-5820-553-23 for removal instructions.) Replace with a calibrated module and repeat test to ensure that the frequency is within the above limits.

Figure 4-98. Frequency Stability Test Setup.

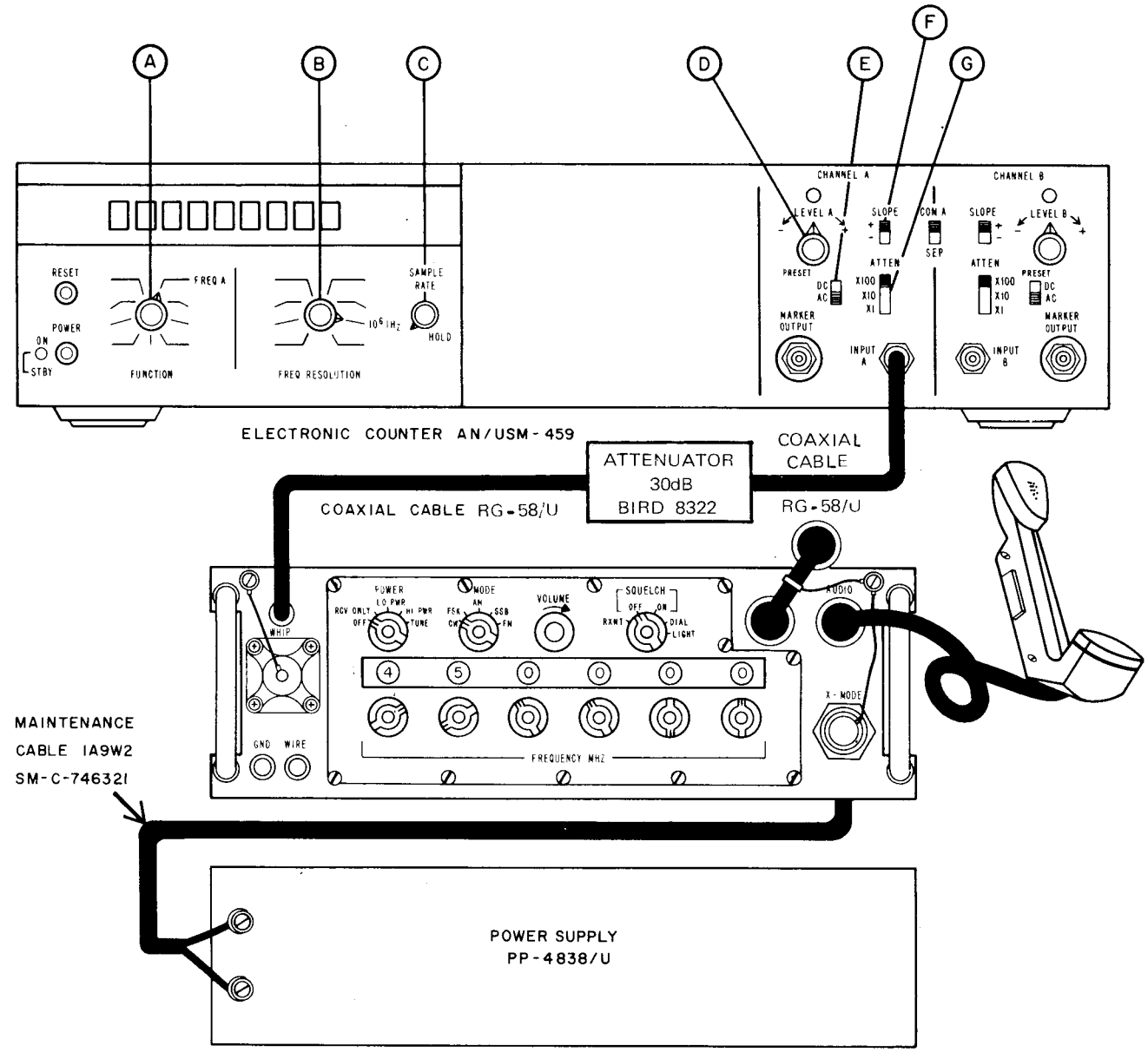

Section VI. Additional Maintenance Instructions

4-14. Scope of Maintenance

This section describes additional maintenance requirements for the radio set. These requirements include cleaning, inspection, repair, removal and replacement, testing, and modifications. Figure FO-4 shows the receiver-transmitter case assembly interconnecting wiring diagram. If the maintenance instructions have been followed, and a particular radio set is still not operating properly, proceed as directed in the following paragraphs.

4-15. Repair Parts

A list of repair parts normally stocked for general maintenance may be found in TM 11-5820-553-23P. A list of tools and test equipment may be found in appendix B, Maintenance Allocation, of this manual.

4-16. Tools and Equipment

The tools and test equipment required for the additional maintenance are Tool Kit, Electronic Equipment TK-105/G and Multimeter ME-26B/U.

4-17. Troubleshooting

If a problem still exists in the case assembly, the fault exists either in the parent board assemblies figures FO-5 and FO-6 or the wiring and components (figure FO-4) external to the parent boards. While keeping in mind the symptoms discovered during the system testing of paragraph 4-12, use a multimeter to test the wiring between parent board assemblies 1A1A31 and 1A1A32 and the accessible components and wiring mounted on the case assembly. If the defect cannot be located and repaired, the RT unit must be forwarded to depot maintenance for repair.

4-18. Cleaning

Clean and lubricate preformed packing and gaskets with insulating silicon compound (NSN 6850-00-880-7616).

4-19. Inspection

Internal visual and mechanical inspection.

4-20. General Testing Procedures

a. Parent Boards 1A1A31 and 1A1A32. Test continuity of parent boards (figures FO-5, FO-6).

b. Fuses 1A1A2F1 and 1A1A2F2. Check fuses F1 and F2 on circuit card 1A1A2 for continuity using Multimeter AN/USM-223.

c. Zener Diode 1A1A2CR4. Check zener diode for forward and reverse resistance using Multimeter AN/USM-223 .

d. BNC ANT Connector 1A1A30J1.

(1) Measure resistance between ANT connector 1A1A30J1 and WIRE connector on front of RT unit. Resistance should be near zero ohms, See figure FO-4.

(2) Connect a BNC-T adapter to ANT connector 1A1A30J1 and measure resistance between BNC-T adapter and WIRE connector on front of RT unit. Resistance should be infinite, indicating open circuit.

e. WHIP Antenna Connector 1A1A30J2.

(1) Remove top cover of RT unit.

(2) Measure resistance between WHIP antenna connector base and terminal E5. (Red wire from connector terminates at E5). Resistance should be infinite, indicating open circuit. See figure FO-4.

(3) Screw base of whip antenna into WHIP connector base and measure resistance between, WHIP antenna connector base and terminal E5. Resistance should be near zero ohms, indicating complete circuit through switch.

4-21. Modifications

Modifications of the radio set will normally be performed at depot level. In the event of modification is to be performed at direct support level, appropriate instructions and parts required will be supplied.

CHAPTER 5

MATERIEL USED IN CONJUNCTION WITH MAJOR ITEM

5-1. General

Operating instructions for the auxiliary equipment used with the radio set are provided in TM

11-5820-553-10. For maintenance and troubleshooting information on the auxiliary equipment, consult the applicable technical manual given in appendix A.

APPENDIX A

REFERENCES

DA Pam 310-1	Consolidated Index of Army Publications and Blank Forms.
DA Pam 738-750	The Army Maintenance Management System (TAMMS).
SB 11-573	Painting and Preservation Supplies Available for Field Use for Electronics Command Equipment.
SB 38-100	Preservation, Packaging, Packing, and Marking Materials, Supplies, and Equipment Used by the Army.
SB 700-20	Army Adopted/Other Items Selected for Authorization/List of Reportable Items.
TB43-0118	Field Instructions for Painting and Preserving Communications-Electronics Equipment.
TM 11-5820-477-12	Operator's and Organizational Maintenance Manual, Radio Set Control Groups AN/GRA-39 (NSN 5820-00-889-3860) and AN/GRA-39A (NSN 5820-00-082-3998) and AN/GRA-39B (NSN 5820-00-949-9909).
TM 11-5820-553-10	Operator's Manual, Radio Set AN/PRC-70 (NSN 5820-01-062-8246).
TM 11-5820-553-23P	Organizational and Direct Support Maintenance Repair Parts and Special Tools (Including Depot Maintenance Repair Parts and Special Tools List), Radio Set AN/ PRC-70 (NSN 5820-01-062-8246) (To be published).
TM 11-5835-224-12	Operator's and Organizational Maintenance Manual: Coderburst Transmission Group AN/GRA-71 (NSN 5820-00-056-6860).
TM 11-5985-237-14P	Operator's, Organization, Direct Support, and General Support Maintenance Repair Parts and Special Tools Lists (Including Depot Maintenance Repair Parts and Special Tools): Attenuator, Variable CN-7961/U, (NSN 5985-00-831-5991).
TM 11-6130-268-15	Operator, Organizational, Direct Support, General Support and Depot Maintenance Manual (Including Repair Parts and Special Tools Lists): Power Supply PP-4838/U.
TM 11-6140-203-14-3	Operator's, Organizational, Direct Support and General Support Manual: Nonaircraft Nickel-Cadmium Batteries.
TM 11-6625-355-45	General Support and Depot Maintenance Manual; Audio Oscillators TS-421/U and TS-421A/U.
TM 11-6625-446-15	Operator's, Organizational, Direct Support, General Support, and Depot Maintenance Manual: Wattmeter AN/URM-120 (NSN 6625-00-813-8430).
TM 11-6625-504-15-1	Operator, Organizational, Direct Support, General Support, and Depot Maintenance Manual: Electronic Voltmeter, AN/USM-145 (NSN 6625-00-973-3986).
TM 11-6625-1576-15	Organizational, Direct Support, General Support, and Depot Maintenance Manual: Distortion Analyzer, Hewlett-Packard Model 333A and 334A.
TM 750-244-2	Procedures for Destruction of Electronics Materiel to Prevent Enemy Use (Communications-Electronics Command).

APPENDIX B

MAINTENANCE ALLOCATION

Section I. Introduction

B-1. General

This appendix provides a summary of the maintenance operations for AN/ PRC-70. It authorizes categories of maintenance for specific maintenance functions on repairable items and components and the tools and equipment required to perform each function. This appendix may be used as an aid in planning maintenance operations.

B-2. Maintenance Function

Maintenance functions will be limited to and defined as follows:

a. Inspect. To determine the serviceability of an item by comparing its physical, mechanical, and/or electrical characteristics with established standards through examination.

b. Test. To verify serviceability and to detect incipient failure by measuring the mechanical or electrical characteristics of an item and comparing those characteristics with prescribed standards.

c. Service. Operations required periodically to keep an item in proper operating condition, i.e., to clean (decontaminate), to preserve, to drain, to paint, or to replenish fuel, lubricants, hydraulic fluids, or compressed air supplies.

d. Adjust. To maintain, within prescribed limits, by bringing into proper or exact position, or by setting the operating characteristics to the specified parameters.

e. Align. To adjust specified variable elements of an item to bring about optimum or desired performance.

f. Calibrate. To determine and cause corrections to be made or to be adjusted on instruments or test measuring and diagnostic equipments used in precision measurement. Consists of comparisons of two instruments, one of which is a certified standard of known accuracy, to detect and adjust any discrepancy in the accuracy of the instrument being compared.

g. Install. The act of emplacing, seating, or fixing into position an item, part, module (component or assembly) in a manner to allow the proper functioning of the equipment or system.

h. Replace. The act of substituting a serviceable like type part, subassembly, or module (component or assembly) for an unserviceable counterpart.

i. Repair. The application of maintenance services (inspect, test, service, adjust, align, calibrate, replace) or other maintenance actions (welding, grinding, riveting, straightening, facing, remachining, or resurfacing) to restore serviceability to an item by correcting specific damage, fault, malfunction, or failure in a part, subassembly, module (component or assembly), end item, or system.

j. Overhaul. That maintenance effort (service/action) necessary to restore an item to a completely serviceable/operational condition as prescribed by maintenance standards (i.e., DMWR) in appropriate technical publications. Overhaul is normally the highest degree of maintenance performed by the Army. Overhaul does not normally return an item to like new condition.

k. Rebuild. Consists of those services/actions necessary for the restoration of unserviceable equipment to a like new condition in accordance with original manufacturing standards. Rebuild is the highest degree of materiel maintenance applied to Army equipment. The rebuild operation includes the act of returning to zero those age measurements (hours, miles, etc.) considered in classifying Army equipments/components.

B-3. Column Entries

a. Column 1, Group Number. Column 1 lists group numbers, the purpose of which is to identify components, assemblies, subassemblies, and modules with the next higher assembly.

b. Column 2, Component/Assembly. Column 2 contains the noun names of components, assemblies, subassemblies, and modules for which maintenance is authorized.

c. Column 3, Maintenance Functions. Column 3 lists the functions to be performed on the item listed in column 2. When items are listed without maintenance functions, it is solely for purpose of having the group numbers in the MAC and RPSTL coincide.

d. Column 4, Maintenance Category. Column b specifies, by the listing of a "work time" figure in the appropriate subcolumn(s), the lowest level of maintenance authorized to perform the function listed in column 3. This figure represents the active time required to perform that maintenance function at the indicated category of maintenance.

SECTION II MAINTENANCE ALLOCATION CHART
FOR
RADIO SET AN/PRC-70

(1) GROUP NUMBER	(2) COMPONENT/ASSEMBLY	(3) MAINTENANCE FUNCTION	(4) MAINTENANCE CATEGORY					(5) TOOLS AND EQPT.	(6) REMARKS
			C	O	F	H	D		
0113	CKT CARD ASSY - UP Conv (1A1A13)	Remove Align			1.01			7 12,13,24,49, 74,85,94	
		Test					0.63	12,13,22,24, 49,85	
		Repair					0.76	7,12,13,24, 25,49,74,75, 85,94	
0114	CKT CARD ASSY - IF SELECTOR (1 A1A14)	Remove Align			1.01			7 3,7,12,13,21 50,74,75,85, 97	
		Test					0.98	3,12,13,18, 21,24,25,50, 85,94,97	
		Repair					0.57	3,7,12,13,18 21,24,25,50, 74,75,85,94, 97	
0115	CKT CARD ASSY - IF & GN (1A1A15)	Remove Align			1.01			7 3,12,13,21,5 74,85	
		Test					0.79	3,12,13,18,1 21,24,25,51, 85,94	
		Repair					0.96	3,7,12,13,18 19,21,24,25, 51,74,75,85, 94	
0116	CKT CARD ASSY - SECOND MIX (1A1A16)	Remove Align			.01			7 3,5,12,21,24 25,52,74,94	
		Test					0.40	3,7,12,13,18 19,21,23,25, 51,74,75,85, 94	
		Repair					0.53	3,5,7,12,13, 18,20,21,24, 25,52,74,75, 85,93,94	
0117	CKT CARD ASSY - SELECTOR IF (1 A1A17)	Remove Align			.01			7 3,5,12,21,23 24,25,49,74, 85,94	
		Test					0.70	3,5,12,18,21 23,24,25,53, 85,94	
		Repair					0.61	3,5,7,12,21, 23,24,25,53, 74,75,85,94	
0118	CKT CARD ASSY - PUMP VFO (1 A1A18)	Remove Align			.01			7 3,12,54,74, 85,96	
		Test					0.38	3,5,12,21,54 85,96	
		Repair					0.59	3,5,7,12,21, 54,74,75,85, 96	
0119	CKT CARD ASSY - IF SELECTION (1 A1A19)	Remove Align			1.01			7 12,13,18,23, 24,25,55,74, 94	
		Test					0.46	3,12,13,18,2 23,23,25,55, 85,94	
		Repair					1.16	3,7,12,13,18 20,21,23,24, 25,55,74,75, 85,94	

SECTION II MAINTENANCE ALLOCATION CHART
FOR

RADIO SET AN/PRC-70

(1) GROUP NUMBER	(2) COMPONENT/ASSEMBLY	(3) MAINTENANCE FUNCTION	(4) MAINTENANCE CATEGORY					(5) TOOLS AND EQPT.	(6) REMARKS
			C	O	F	H	D		
00	RADIO SET AN/PRC-70	Inspect Install Service	0.28 1.40						
		Test Test Repair	0.08 0.31	0.96				16	A
01	RECEIVER-TRANSMITTER RT-1133/PRC-70 (1A1)	Service Remove Test	0.03	0.07	0.58			1 thru 5,10, 12 thru 15, 18,19,20,27, 95	
		Test Test			0.53			1 thru 5,9, 10,12,15,18, 19,20,85,100 101,103-111, 113-115	K
		Align						2,3,4,9,10, 12,13,15,20, 24,30,32,71 thru 74,85, 99-111,113- 115	K
		Repair Repair		0.01	0.91			6 1 thru 5, 7 thru 15, 17 thru 21	K
		Repair					1.76	1 thru 5,7 thru 15,17 thru 21, 67, 74,75,85	
0101	SELECTOR ASSY, FREQ (1A1A1)	Remove Test Repair Repair			0.06 0.14		1.15 7 1.54	7 12,37,85 7 5,7,12,20,36 37,75,85	D
010101									E
010102									E
01010201									E
0102	CKT CARD ASSY, PWR & TR (1A1A2)	Remove Test Test Repair Repair			0.01 0.02 0.08		0.25	7 11,12 11,12,38,85 7,11,12	F F
0103	CKT CARD ASSY - IF GAIN (1A1A3)	Remove Align Test Repair			0.01		0.44 1.30 1.51	7 3,12,13,21, 39,74,85 3,12,13,21, 39,85 3,7,12,13,20, 21,39,74,75, 85	
0104	CKT CARD ASSY - PWR SUP (1A1A4)	Remove Test Repair			0.01		0.56 0.66	7 7,12,20,40, 75,85 7,12,20,40, 75,85	
0105	CKT CARD ASSY - PWR SUP (1A1A5)	Remove Test Repair			0.01		0.42 0.86	7 5,7,12,20, 28,41,75,85 5,7,12,20,28, 41,75,85	

SECTION II MAINTENANCE ALLOCATION CHART
FOR

RADIO SET AN/PRC-70

(1) GROUP NUMBER	(2) COMPONENT/ASSEMBLY	(3) MAINTENANCE FUNCTION	(4) MAINTENANCE CATEGORY					(5) TOOLS AND EQPT.	(6) REMARK
			C	O	F	H	D		
0106	ELECT COMP ASSY (1A1A6)	Remove Align			0.01			7 3,12,13,23, 24,25,42,74, 94	
		Test				0.59	0.72	3,12,13,23, 24,25,42,85, 94	
							1.11	3,7,12,23,24, 25,42,74,75, 85,94	
010601	CKT CARD ASSY - UPPER LP (1A1A7)	Remove Align			0.01			7	E
010602		Test				0.57	2.02	5,7,12,13,18, 20,28,43,75, 83,85	
0107		Repair					2.19	5,12,13,18,20, 43,83,85 5,7,12,13,18, 20,36,43,75, 83,85	
0108	CKT CARD ASSY - UPPER LP (1A1A8)	Remove Align			0.01			7	
		Test				0.33	1.07	12,44,74,85 12,20,23,44, 83,85	
		Repair					1.14	7,12,20,23, 44,74,75,83, 85	
0109	CKT CARD ASSY - LWR LP (1A1A9)	Remove Align			0.01			7	
		Test				0.42	1.13	12,23 thru 26, 45,74,83,85, 94	
		Repair					1.35	3,5,12,18,21, 23 thru 26, 45,83,85,94 3,5,7,12,18, 20,21,23 thru 26,45,74,75, 83,85,94	
0110	CKT CARD ASSY - OSC D&S (1A1A10)	Remove Align			0.01			7	
		Test				1.58	0.88	3,5,7,12,19, 20,21,23,29, 46,74,75,85 3,5,12,13, 18 thru 21,23, 24,25,29,46, 85,94	
		Repair					1.75	3,5,7,12, 18 thru 21,23, 24,25,29,46, 74,75,85,94	
0111	CKT CARD ASSY - OSC DIV (1A1A11)	Remove Align			0.01			7	
		Test				0.46	0.53	5,7,12,20,47, 74,85 3,5,12,20,21, 47,85	
		Repair			0.53		0.79	3,5,7,12,20, 21,47,74,75, 85	
0112	CKT CARD ASSY - XMT BB (1A1A12)	Remove Test			0.01			7	
		Repair					0.70	3,12,13,20, 48,85,92,93, 96	
							0.80	3,7,12,13,20, 48,75,85,92, 93,96	

SECTION II MAINTENANCE ALLOCATION CHART
FOR
RADIO SET AN/PRC-70

(1) GROUP NUMBER	(2) COMPONENT/ASSEMBLY	(3) MAINTENANCE FUNCTION	(4) MAINTENANCE CATEGORY					(5) TOOLS AND EQPT.	(6) REMARKS
			C	O	F	H	D		
0113	CKT CARD ASSY - UP Conv (1A1A13)	Remove Align			1.01			7 12,13,24,49, 74,85,94	
		Test					0.63	12,13,22,24, 49,85	
		Repair					0.76	7,12,13,24, 25,49,74,75, 85,94	
0114	CKT CARD ASSY - IF SELECTOR (1 A1A14)	Remove Align			1.01			7 3,7,12,13,21 50,74,75,85, 97	
		Test					0.98	3,12,13,18, 21,24,25,50, 85,94,97	
		Repair					0.57	3,7,12,13,18 21,24,25,50, 74,75,85,94, 97	
0115	CKT CARD ASSY - IF & GN (1A1A15)	Remove Align			1.01			7 3,12,13,21,5 74,85	
		Test					0.79	3,12,13,18,1 21,24,25,51, 85,94	
		Repair					0.96	3,7,12,13,18 19,21,24,25, 51,74,75,85, 94	
0116	CKT CARD ASSY - SECOND MIX (1A1A16)	Remove Align			.01			7 3,5,12,21,24 25,52,74,94	
		Test					0.40	3,7,12,13,18 19,21,23,25, 51,74,75,85, 94	
		Repair					0.53	3,5,7,12,13, 18,20,21,24, 25,52,74,75, 85,93,94	
0117	CKT CARD ASSY - SELECTOR IF (1 A1A17)	Remove Align			.01			7 3,5,12,21,23 24,25,49,74, 85,94	
		Test					0.70	3,5,12,18,21 23,24,25,53, 85,94	
		Repair					0.61	3,5,7,12,21, 23,24,25,53, 74,75,85,94	
0118	CKT CARD ASSY - PUMP VFO (1 A1A18)	Remove Align			.01			7 3,12,54,74, 85,96	
		Test					0.38	3,5,12,21,54 85,96	
		Repair					0.59	3,5,7,12,21, 54,74,75,85, 96	
0119	CKT CARD ASSY - IF SELECTION (1 A1A19)	Remove Align			1.01			7 12,13,18,23, 24,25,55,74, 94	
		Test					0.46	3,12,13,18,2 23,23,25,55, 85,94	
		Repair					1.16	3,7,12,13,18 20,21,23,24, 25,55,74,75, 85,94	

SECTION II MAINTENANCE ALLOCATION CHART
FOR
RADIO SET AN/PRC-70

(1) GROUP NUMBER	(2) COMPONENT ASSEMBLY	(3) MAINTENANCE FUNCTION	(4) MAINTENANCE CATEGORY					(5) TOOLS AND EQPT.	(6) REMARKS
			C	O	F	H	D		
0120	CKT CARD ASSY - DC CONTROL (1A1A20)	Remove Test Repair			0.01			7 20,56,79,85 1.00 7,20,56,75, 79,85	
0121	CKT CARD ASSY - MOD SQUELCH (1 A1A21)	Remove Align Test Repair			0.01			7 2,4,7,12,13, 18,20,21,57, 74,75,85 0.88 2,4,12,18,20, 21,24,25,57, 85,94 1.08 2,4,7,12,13, 18,20,21,23, 25,26,57,74, 75,85	
0122	CKT CARD ASSY - IF DET (1 A1A22)	Test Repair Align			0.01			7 4,5,12,20,23, 59,85 1.31 4,5,7,12,20, 23,59,75,85, 112 1.35 3,7,12,13,20, 21,23,28,58, 74,75,85,112	
0123	CKT CARD ASSY - AUDIO (1 A1A23)	Remove Test Repair			0.01			7 4,5,12,20,23, 59,85 1.31 4,5,7,12,20, 23,59,75,85	
0124	COUPLER ASSY (1 A1A24)	Remove Repair			0.19			7,12,14 0.08 7	
012401	COUPLER NETWORK (1A1A24A1)	Test Repair						1.48 12,33,60,76, 85 1.23 7,12,33,60, 75,76,85	
012402	ELEC COMPONENT ASSEMBLY (1A1A24A2)	Remove						0.02 7	
01240201	CKT CARD ASSY, COUPLER (1A1A24A2A1)	Test Repair						0.47 12,20,68,85 0.70 7,12,20,68, 75,85	
01240202	CKT CARD ASSY, COUPLER (1A1A24A2A2)	Test Align Repair						1.71 12,20,69,85 98 0.86 7,12,69,74, 85,98 1.37 7,12,20,36 69,74,75,85, 98	J J J
0125	CKT CARD ASSY - ALC (1A1A25)	Remove Align Test Repair			0.01			7 0.39 61,74,79,85 0.47 20,61,78,79, 82,85 0.53 7,20,61,74, 75,78,79,82, 85	
0126	SWITCH, RF XMISS LINE (1 A1A26)	Remove Test Repair						1.20 7,14,79 0.44 14,62,79 0.65 7,62,75,79,85	
0127	CKT CARD ASSY - DET (1 A1A27)	Remove Align			0.25			7,12,14 1.34 7,12,13,22,31 35,63,64,74, 75,77,80,81, 84,85,88,90	

SECTION II MAINTENANCE ALLOCATION CHART
FOR
RADIO SET AN/PRC-70

(1) GROUP NUMBER	(2) COMPONENT/ASSEMBLY	(3) MAINTENANCE FUNCTION	(4) MAINTENANCE CATEGORY					(5) TOOLS AND EQPT.	(6) REMARKS
			C	O	F	H	D		
0128	CKT CARD ASSY - HARMONIC FILTER (1A1A28)	Test					1.05	1,6,12,13,31, 35,63,64,77, 80,81,84,85, 88,90	
		Repair					2.24	6,7,12,13,31, 35,63,64,74, 75,77,80,81, 84,88,90	
		Remove			0.11			7,12,14	
		Align					0.10	12,65,88,89, 90	
		Test					1.12	12,65,88,89, 90	
0129	CKT CARD ASSY - PA & DRIVER (1A1A29)	Repair					0.94	3,7,12,20,65, 75,85,88,89, 90	
		Remove			0.05			10	
		Test					1.51	6,8,12,13,24, 25,29,31,35, 66,76,77,85, 86,87,91,94	
012901		Repair					2.24	6,7,8,12,13, 24,25,29,31, 35,66,75,76, 77,85,86,87, 91,94	E
0130	CASE, RCVR-XMTR (1A1A30)	Test			0.11			7	G
		Repair			0.32			7,10	
		Repair					1.64	7,10,11	
013001	CONNECTOR ASSY, RF (1A1A30A1)	Remove			0.22			7	
		Repair					0.29	7,85	
013002	CONNECTOR ASSY, ELEC (1 A1A30J2)	Remove			0.33			7	
		Repair					0.01	7,75,85	
0131	CKT CARD ASSY - INT BD (1 A1A31)	Remove					2.57	7,75	
		Test					1.97	85	
		Repair					0.41	7,75,85	
0132	CKT CARD ASSY - PA BOARD (1 A1A32)	Remove					0.77	7,10,12,14, 75	
		Test					0.53	85	
013201	RELAY ASSY	Remove					0.01	7,10,12,14, 75	
		Repair					0.25	7,75	
013202									E
013203									E
0133	ELECT COMPONENT ASSY (1A1A33)	Remove			0.22			7	
		Test					0.42	11,12,70,85	
		Repair					0.48	7,11,12,70, 75,85	
013301									E
013302									E
0134	FILTER, BAND PASS (1A1FL1)								E

SECTION II MAINTENANCE ALLOCATION CHART
FOR
RADIO SET AN/PRC-70

(1) GROUP NUMBER	(2) COMPONENT/ASSEMBLY	(3) MAINTENANCE FUNCTION	(4) MAINTENANCE CATEGORY					(5) TOOLS AND EQPT.	(6) REMARKS
			C	O	F	H	D		
02	ANTENNA AS-2974 /PRC-70	Repair		0.03					I
03	ANTENNA AS-2975 /PRC-70	Repair		0.03					I
0301	BALUN ASSY	Remove Repair Test		0.03	0.26 0.08			7 3,13	
20	MAINTENANCE KIT	Test Repair			0.03 0.28			11	H

SECTION III TOOL AND TEST EQUIPMENT REQUIREMENTS
FOR
RADIO SET AN/PRC-70

DOL OR TEST EQUIPMENT REF CODE	MAINTENANCE CATEGORY	NOMENCLATURE	NATIONAL/NATO STOCK NUMBER	TOOL NUMBER
1	F,D	RF VOLTAGE DIVIDER 91-7C	6625-00-070-4032	
2	F,D	AUDIO OSCILLATOR AN/URM-127	6625-00-783-5965	
3	F,D	VOLTMETER, ELECTRONIC AN/URM-145	6625-00-973-3986	
4	F,D	DISTORTION ANALYZER AN/URM-184A	6625-00-802-8718	
5	F,D	ELECTRONIC COUNTER AN/USM-459	6625-01-121-6934	
6	O,F,D	TOOL KIT, ELECTRONIC EQUIPMENT TK-101/G	5180-00-064-5178	
7	F,D	TOOL KIT, ELECTRONIC EQUIPMENT TK-105/G	5180-00-610-8177	
8	F,D	ATTENUATOR, VARIABLE CN-796/U	5985-00-831-5991	
9	F,D	ATTENUATOR, FIXED 8322	5985-00-763-8025	
10	F,D	MAINTENANCE KIT B4024860		
11	F,D	MULTIMETER AN/USM-223	6625-00-999-7465	
12	F,D	POWER SUPPLY PP-4838/U	6625-00-931-6793	
13	F,D	SIGNAL GENERATOR SG-1093/U	6625-00-318-6304	
14	F,D	MAINTENANCE CABLE P/O AN/PRC-70 SM-C-746321(1A9W2)	5995-01-092-5943	
15	F,D	FM DEVIATION METER TF-791D	6625-00-060-3320	
16	O	MULTIMETER AN/URM-105C	6625-00-999-6282	
17	F,D	ADAPTER UG-201/U	6625-00-498-4747	
18	F,D	ADAPTER CONNECTOR UG-274/U	5935-00-926-7523	
19	F,D	ADAPTER CONNECTOR UG-914A/U	5935-01-037-3746	
20	F,D	OSCILLOSCOPE AN/USM-281C	6625-00-106-9622	
21	F,D	ADAPTER CONNECTOR 91-6C	5935-00-892-9773	
22	D	COUPLER, BIDI RECTIONAL CD-920-4	5985-01-024-5331	
23	D	GENERATOR, SWEEP FG-504T	6625-01-054-1399	
24	D	SPECTRUM ANALYZER IP-1216/GR	6625-00-424-4370	
25	D	PLUG IN UNIT PL-1399/U	6625-00-432-5055	
26	D	TRACKER GENERATOR SG-1122/U	6625-00-155-5990	
27	F,D	POWER SUPPLY HP-6214A	6130-01-063-4933	
28	D	DECADE RESISTOR BOX ZM-57/U	6625-00-935-1470	
29	D	DUMMY LOAD, ELECTRIC O11-0049-01	5985-00-087-4954	
30	D	ATTENUATOR, 40 dB O171-874		
31	D	POWER METER 1045		
32	D	ADAPTER, PROBE 11042A	5985-00-713-4856	
33	D	POWER TRANSFORMER 116B	6120-00-772-7917	
34	D	ADAPTER, CONNECTOR 1269	5935-00-053-9454	
35	D	POWER SENSOR 1393B		
36	D	LOGIC ANALYZER 1601L	6625-00-595-7642	
37	D	TEST FIXTURE, 1A1A1 2301-874		
38	D	TEST FIXTURE, 1A1A2 2302-874		
39	D	TEST FIXTURE, 1A1A3 2303-874		
40	D	TEST FIXTURE, 1A1A4 2304-874		

SECTION III TOOL AND TEST EQUIPMENT REQUIREMENTS
FOR
RADIO SET AN/PRC-70

TOOL OR TEST EQUIPMENT REF CODE	MAINTENANCE CATEGORY	NOMENCLATURE	NATIONAL/NATO STOCK NUMBER	TOOL NUMBER
41	D	TEST FIXTURE, 1A1A5 2305-874		
42	D	TEST FIXTURE, 1A1A6 2306-874		
43	D	TEST FIXTURE, 1A1A7 2307-874		
44	D	TEST FIXTURE, 1A1A8 2308-874		
45	D	TEST FIXTURE, 1A1A9 2309-874		
46	D	TEST FIXTURE, 1A1A10 2310 -874		
47	D	TEST FIXTURE, 1A1A11 2311-874		
48	D	TEST FIXTURE, 1A1A12 2312-874		
49	D	TEST FIXTURE, 1A1A13 2313-874		
50	D	TEST FIXTURE, 1A1A14 2314-874		
51	D	TEST FIXTURE, 1A1A15 2315-874		
52	D	TEST FIXTURE, 1A1A16 2316 -874		
53	D	TEST FIXTURE, 1A1A17 2317-874		
54	D	TEST FIXTURE, 1A1A18 2318-874		
55	D	TEST FIXTURE, 1A1A19 2319-874		
56	D	TEST FIXTURE, 1A1A20 2320-874		
57	D	TEST FIXTURE, 1A1A21 2321-874		
58	D	TEST FIXTURE, 1A1A22 2322-874		
59	D	TEST FIXTURE, 1A1 A23 2323-874		
60	D	TEST FIXTURE, 1A 1A24A1 2324-874		
61	D	TEST FIXTURE, 1A1 A25 2325-874		
62	D	TEST FIXTURE, 1A1A26 2326-874		
63	D	TEST FIXTURE, 1A1A27 2327-874		
64	D	ANALYZER OVERLAY 2327-874-10		
65	D	TEST FIXTURE, 1A1A28 2328-874		
66	D	TEST FIXTURE, 1A 1A29 2329-874		
67	D	TEST FIXTURE, 1A 1FL1 2330-874		
68	D	TEST FIXTURE, 1A1A24A2A1 2331-874		
69	D	TEST FIXTURE, 1A 1A24A2A2 2332-874		
70	D	TEST FIXTURE, 1A1A33 2333-874		
71	D	EXTENDER CARD, IF SELECTOR 2359 -874		
72	D	EXTENDER CARD, MOD SWITCH 2369-874		
73	D	POWER CABLE 2373-874		
74	D	ALIGNMENT TOOL 2520	5120-00-778-6241	
75	D	SOLDERING STATION 300MDK	3489-00-907-5806	
76	D	IMPEDANCE METER 4R15A	6625-00-061-0225	
77	D	SIGNAL GENERATOR 550L	6625-01-112-1926	
78	D	POWER SUPPLY 6111A	6130-01-063-5642	
79	D	POWER SUPPLY 721A	6625-00-445-6933	
80	D	ATTENUATOR 757C	5985-00-772-0465	

SECTION III TOOL AND TEST EQUIPMENT REQUIREMENTS
FOR
RADIO SET AN/PRC-70

OOL OR TEST EQUIPMENT REF CODE	MAINTENANCE CATEGORY	NOMENCLATURE	NATIONAL/NATO STOCK NUMBER	TOOL NUMBER
81	D	ATTENUATOR 766-6	6625-00-140-8316	
82	D	PULSE GENERATOR 8005B	6625-01-045-6274	
83	D	WORD GENERATOR 8018A		
84	D	DUMMY LOAD 8135	6625-00-773-7311	
85	D	DIGITAL MULTIMETER 8300A	6625-00-262-4072	
86	D	FIXED ATTENUATOR 8325	5985-00-433-0067	
87	D	POWER ATTENUATOR 8341-030		
88	D	STORAGE NORMALIZER 8501A	6625-01-113-7358	
89	D	TEST SET, S-PARAMETER 8503A	6625-01-081-4094	
90	D	NETWORK ANALYZER 8505A	6625-01-103-7001	
91	D	ATTENUATOR, 0-10 dB 905	5985-00-840-2394	
92	D	TEST ADAPTER 91-14A	6625-00-104-8967	
93	D	50 OHM TERMINATION 91-15A	6625-00-104-8990	
94	D	PLUG IN UNIT PL-1388/U	6625-00-431-9339	
95	D	HANDSET H-250A/U	5965-00-043-3463	
96	D	DUMMY LOAD DA-75/U	6625-00-177-1639	
97	D	POWER DIVIDER THV-50-9011		
98	D	TEST FIXTURE, 1A1A24A2A2 A3049458		
99	D	EXTENDER CARD 2498-874		
100	D	ADAPTER CONNECTOR 0161-874		
101	D	ADAPTER ASSEMBLY 0162-874		
102	D	AGC SWITCH BOX 2345-874		
103	D	PUSH-TO-KEY BOX 2375-874		
104	D	ADAPTER ASSY 2486-874		
105	D	ANTENNA SIMULATOR 2484-874-3		
106	D	ANTENNA SIMULATOR 2484-874-5		
107	D	ANTENNA SIMULATOR 2459-874		
108	D	ADAPTER CONNECTOR UG-491A/U	5935-00-681-5013	
109	D	CABLE, LEpra-CON TO BNC 0174-874-4		
110	D	POWER SUPPLY 6002A		
111	D	VOLTMETER, AC ME-303A/U		
112	D	BRIDGE, IMPEDANCE ZM-71/U	6625-00-236-1536	
113	D	CAPACITOR, LOAD 2487-874		
114	D	TEST FIXTURE, 1A1 2355-874		
115	D	TEST FIXTURE, 1A1 2445-874		

SECTION IV. REMARKS

REFERENCE CODE	REMARKS
A	REPAIR BY REPLACEMENT OF COMPONENTS (RT-1133, BAG, POWER CABLE, HANDSET, HEADSET, KY-562/U, CX-13101).
B	REPAIR BY REPLACEMENT OF DUST COVER, ANTENNA COVER, KNOBS, CONNECTOR PLUG.
C	REPAIR BY REPLACEMENT OF MODULES, HANDLES, GASKETS, CABLES,
D	REPAIR BY REPLACEMENT OF INDICATOR LAMPS.
E	REQUIRED AGAINST NEXT HIGHER ASSEMBLY.
F	REPAIR BY REPLACEMENT OF FUSE AND ZENER.
G	REPAIR BY REPLACEMENT OF 1A1A30J1, 1A1A30J2, 1A1A30A2, WIRE TERMINALS, BATTERY CONNECTORS.
H	REPAIR BY REPLACEMENT OF PIECE PARTS (CABLES, WRENCH, BOXES, CARD).
I	REPAIR BY REPLACEMENT OF PIECE PARTS.
J	TEST FIXTURE 2332-874 IS REQUIRED FOR 1A1A24A2A2 P/N SM-D-746481. TEST FIXTURE A3049458 IS REQUIRED FOR 1A1A24A2A2 P/N B4029214.
K	TEST FIXTURE 2355-874 IS REQUIRED FOR 1A1A24A2A2 P/N SM-D-746481. TEST FIXTURE 2445-874 IS REQUIRED FOR 1A1A24A2A2 P/N B4029214.

APPENDIX C

EXPENDABLE SUPPLIES AND MATERIALS LIST

Section I. Introduction

C-1. Scope

This appendix lists expendable supplies and materials you will need to operate and maintain the AN/PRC-70. These items are authorized to you by CTA 50-970, Expendable Items (Except Medical, Class V, Repair Parts, and Heraldic Items).

C-2. Explanation of Columns

a. Column 1 - Item Number. This number is assigned to the entry in the listing and is referenced in the narrative instructions to identify the material (e.g., "Use cleaning compound, item 5, App. D").

b. Column 2 - Level. This column identifies the lowest level of maintenance that requires the listed item.

C - Operator/Crew

O - Organizational Maintenance

F - Direct Support Maintenance

H - General Support Maintenance

c. Column 3 - National Stock Number. This is the National stock number assigned to the item; use it to request or requisition the item.

d. Column 4 - Description. Indicates the Federal item name and, if required, a description to identify the item. The last line for each item indicates the part number followed by the Federal Supply Code for Manufacturer (FSCM) in parentheses, if applicable.

e. Column 5 - Unit of Measure (U/M). Indicates the measure used in performing the actual maintenance function. This measure is expressed by a two-character alphabetical abbreviation (e.g., ea, in, pr). If the unit of measure differs from the unit of issue, requisition the lowest unit of issue that will satisfy your requirements.

(Next printed page is C-2)

SECTION II EXPENDABLE SUPPLIES AND MATERIALS LIST

(1) ITEM NO.	(2) LEVEL	(3) NATIONAL STOCK NUMBER	(4) DESCRIPTION PART NO AND FSCM	(5) UNIT OF MEAS
1	O,F	850-00-105-3084	TRICHLOROTRIFLUOROETHANE 16 OZ OT620	OZ
		850-00-984-5853	TRICHLOROTRIFLUOROETHANE 5 GAL	GL
2	O,F		SANDPAPER P-C-451	EA
3	O,F		ZINC CHROMATE PRIMER PAINT FINISH NO. P513/2 PER MIL-F- 14072, FINAL FILM PER TT-E-529	OZ
4	O,F	850-00-880-7616	SILICON COMPOUND DC4 (71984)	OZ
5	O,F		PAINT, OLIVE DRAB NO. 24087 PER STANDARD FED-STD-595	OZ
6	O,F		CLOTH CCC-C-440	EA
7	O,F		SEALING COMPOUND PER MIL-S-46163 TYPE II GRADE M	
8	O,F		ADHESIVE, SCOTCHGRIP 1300L (04963)	
9	O,F		LUBRICANT FS3452 (71984)	
10	O,F		ADHESIVE RTV-734 (71984)	
11	O,F		ADHESIVE EC 1300	
12	F		GASKET SM-B-746737	
13	F		SOLDER SN60WRMAP2 PER SPECIFICATION QQ-S-571	

INDEX

Subject	Paragraph, Figure, or Table Number
Adjustment and Alignment	4-8
Administrative Storage	1-5
Automatic Level Control (ALC) Module (1A1A25)	
Functional Analysis	3-28, F3-24
Removal	4-10b(3), F4-90, F4-91
Replacement	4-10b(4), F4-90
Assembly and Disassembly	4-10
Audio Module (1A1A23)	
Functional Analysis	3-26, F3-22
Removal	4-10b(3), F4-90, F4-91
Replacement	4-10b(4), F4-90
Bandswitch Assembly (1A1A26)	
Functional Analysis	3-29, F3-25
Removal and Replacement	4-10b(7)
Calibration	1-6
Chassis Assembly (1A1A30)	
Removal and Replacement	4-10b(14)
Consolidated Index of Army Publications	1-2
Coupler Module (1A1A24)	
Functional Analysis	3-27, F-23
Removal	4-10b(5), F4-90, FO-7
Replacement	4-10b(5), F4-90
Coupler Parent Board (1A1A32)	
Removal and Replacement	4-10b(14)
Cross Reference	1-12, T1-1
Data, Tabulated	1-11
DC Control Module (1A1A20)	
Functional Analysis	3-23, F3-19
Removal	4-10b(3), F4-90, F4-91
Description	1-10
Destruction of Materiel	1-4
Detailed Block Diagram Analysis	3-3, FO-2
Detector Module (1A1A27)	
Functional Analysis	3-30, F3-26
Removal	4-10b(8), F4-90, F4-91, FO-7
Replacement	F4-90, FO-7
Digital Divider Module (1A1A11)	
Functional Analysis	3-14, F3-10
Removal	4-10b(3), F4-90, F4-91
Replacement	4-10b(4), F4-90
Errors, Reporting	1-7
Evaluation Tests	4-5
Expendable Supplies	Appx C
Receive Evaluation Tests	
AGC Test	4-5a(3), F4-2, T4-2
FM Sensitivity Test	4-5a(10), F4-2, T4-2

Subject	Paragraph, Figure, or Table Number
Expendable Supplies (Cont.)	
Receive Evaluation Tests (Cont.)	
Retransmit Test	4-5a(6), F4-2, T4-2
Sensitivity Test	4-5a(2), F4-2, T4-2
Squelch Test	4-5a(5), F4-2, T4-2
SSB Sensitivity Test	4-5a(9), F4-2, T4-2
Test Setup	4-5a(1), F4-2, F4-3, F4-4, T4-2
Wide Band (X-Mode) Audio Response Test	4-5a(7), F4-2, T4-2
Transmit Evaluation Tests	
AM and SSB Output Tests	4-5b(2), T4-3
AM Modulation Test	4-5b(3), F4-7, F4-75
CW/FSK Modulation Test	4-5b(5)
FM Modulation Test	4-5b(7)
FM Output Test	4-5b(9)
FM Power Output Test	4-5b(10), T4-3
Sidetone/No-Tune Tone Test	4-5b(4), F4-8
SSB/RF Power Output Test	4-5b(6), T4-3
Test Setup	4-5b(1), F4-5, F4-6, T4-3
Wide Band X-Mode Test	4-5b(8)
Test Setup	4-5 b(1), F4-5, F4-6, Tr-3
Wide Band X-Mode Test	4-5b(8)
Filter Assembly (1A1FL1)	
Functional Analysis	3-34
Final Performance Tests	4-12, F4-4
First IF AGC and Gain Module (1A1A15)	
Functional Analysis	3-18, F3-14
Removal	4-10b(3), F4-90, F4-91
Replacement	4-10b(4), F4-90
First IF Selectivity Module (1A1A14)	
Functional Analysis	3-17, F3-13
Removal	4-10b(3), F4-90, F4-91
Replacement	4-10b(4), F4-90
Frequency Selector (1A1A1)	
Functional Analysis	3-4, F0-3
Removal	4-10b(1), F4-90, F4-91
Replacement	4-10b(2), F4-90
Functional Analysis	
Frequency Selector (1A1A1)	3-4, F0-3
TR Relay Module (1A1A2)	3-5, F3-1
IF Gain Module (1A1A3)	3-6, F3-2
10V Power Supply Module (1A1A4)	3-7, F3-3
-5V Power Supply Module (1A1A5)	3-8, F3-4
Translator Module (1A1A6)	3-9, F3-5
Upper Loop Divider Module (1A1A7)	3-10, F3-6
Phase Detector Module (1A1A8)	3-11, F3-7
Lower Loop Module (1A1A9)	3-12, F3-8
Oscillator Distributor Module (1A1A10)	3-13, F3-9
Digital Divider Module (1A1A11)	3-14, F3-10
Transmit Broadband Module (1A1A12)	3-15, F3-11
Up Converter Module (1A1A13)	3-16, F3-12
First IF Selectivity Module (1A1A14)	3-17, F3-13

Subject	Paragraph, Figure, or Table Number
Functional Analysis (Cont.)	
First IF AGC and Gain Module (1A1A15)	3-18, F3-14
Second Mixer Module (1A1A16)	3-19, F3-15
Second IF Module (1A1A17)	3-20, F3-16
VFO Module (1A1A18)	3-21, F3-17
IF Selectivity Module (1A1A19)	3-22, F3-18
DC Control Module (1A1A20)	3-23, F3-19
Modulation/Squelch Module (1A1A21)	3-24, F3-20
IF Detector Module (1A1A22)	3-25, F3-21
Audio Module (1A1A23)	3-26, F3-22
Coupler Module (1A1A24)	3-27, F3-23
Automatic Level Control (ALC) Module (1A1A25)	3-28, F3-24
Bandswitch Assembly (1A1A26)	3-29, F3-25
Detector Module (1A1A27)	3-30, F3-26
Harmonic Filter Module (1A1A28)	3-31, F3-27
PA Module (1A1A29)	3-32, F3-28
Quad Assembly (1A1A33)	3-33, F3-29
Filter Assembly (1A1AFL1)	3-34
Harmonic Filter Module (1A1A28)	
Functional Analysis	3-31, F3-27
Removal	4-10b(10), F4-90, F4-91, FO-7
Replacement	4-10b(11), F4-90
IF Detector Module (1A1A22)	
Functional Analysis	3-28, F3-21
Removal	4-10b(3), F4-90, F4-91
Replacement	4-10b(4), F4-90
IF Gain Module (1A1A3)	
Functional Analysis	3-6, F3-2
Removal	4-10b(3), F4-90, F4-91
Replacement	4-10b(4), F4-90
IF Selectivity Module (1A1A19)	
Functional Analysis	3-22, F3-18
Removal	4-10b(3), F4-90, F4-91
Replacement	4-10b(4), F4-90
Improvement Recommendations	
	1-7
Lower Loop Module (1A1A9)	
Functional Analysis	3-12, F3-8
Removal	4-10b(3), F4-90, F4-91
Replacement	4-10b(4), F4-90
Maintenance Allocation	
	Appx B
Maintenance Forms, Records and Reports	
	1-3
Maintenance Instructions, General (Org)	
	2-5, T2-1
Materials Used	
	5-1
Modulation/Squelch Module (1A1A21)	
Functional Analysis	3-24, F3-20
Removal	4-10b(3), F4-90, F4-91
Replacement	4-10b(4), F4-90
Oscillator Distributor Module (1A1A10)	
Functional Analysis	3-13, F3-9
Removal	4-10b(3), F4-90, F4-91

Subject	Paragraph, Figure, or Table Number
Oscillator Distributor Module (1A1A10) (Cont.)	
Replacement	4-10b(4), F4-90
PA Module(1A1A29)	
Functional Analysis	3-32, F3-28
Removal	4-10b(3), F4-90, F4-91
Replacement	4-10b(4), F4-90
Performance Tests, Final	4-12, F4-4
Receiver Performance Tests	4-12a
AGCTest	4-12a(3), F4-92, T4-7
FM Sensitivity Test	4-12a(10), F4-92, T4-7
FSK/CW Sensitivity Test	4-12a(8), F4-92, T4-7
Narrow Band Audio Test	4-12a(4), F4-92, T4-7
Retransmit Test	4-12a(6), F4-92, T4-7
Sensitivity Test	4-12a(12), T4-7
Squelch Test	4-12a(5), F4-92, T4-7
SSB Sensitivity Test	4-12a(9), F4-92, T4-7
Test Setup	4-12a(1), F4-92, F4-93, T4-7
Wide Band (X-Mode) Audio Response Test	4-12a(7), F4-92, T4-7
Transmit Performance Tests	4-12b, F4-95
AM and SSB Output Test	4-12b(2), F4-96, T4-8
AM Modulation Test	4-12b(3), F4-17
CW/FSK Modulation Test	4-12b(5)
FM Modulation Test	4-12b(7)
FM Output Test	4-12b(9)
Sidetone/No-Tune Tone Test	4-12b(6), T4-8
SSB Output Test	4-12b(6), T4-8
Test Setup	4-12b(1), F4-94, F4-95, T4-8
Wide Band X-Mode Test	4-12b(8)
Performance Standards	4-13
Phase Detector Module (1A1A8)	
Functional Analysis	3-11, F3-7
Removal	4-10b(3), F4-90, F4-91
Replacement	4-10b(4), F4-90
Preventive Maintenance Checks and Services (Org)	2-3, T2-1
Purpose and Use	1-9
Quad Assembly (1A1A33)	
Functional Analysis	3-33, F3-29
Removal	4-10b(15), F4-90
Replacement	4-10b(16), F4-90
Receiver/Exciter Parent Board 1A1A31)	
Removal	4-10b(14)
Replacement	4-10b(14)
Removal	
Frequency Selector (1A1A1)	4-10b(1), F4-90, F4-91
TR Relay Module (1A1A2)	4-10b(3), F4-90, F4-91
IF Gain Module (1A1A3)	4-10b(3), F4-90, F4-91
10V Power Supply Module (1A1A4)	4-10b(3), F4-90, F4-91
-5V Power Supply Module (1A1A5)	4-10b(3), F4-90, F4-91
Translator Module (1A1A6)	4-10b(3), F4-90, F4-91
Upper Loop Divider Module (1A1A7)	4-10b(3), F4-90, F4-91

Subject	Paragraph, Figure, or Table Number
Removal (Cont.)	
Phase Detector Module (1A1A8)	4-10b(3), F4-90, F4-91
Lower Loop Module (1A1A9)	4-10b(3), F4-90, F4-91
Oscillator Distributor Module (1A1A10)	4-10b(3), F4-90, F4-91
Digital Divider Module (1A1A11)	4-10b(3), F4-90, F4-91
Transmit Broadband Module (1A1A12)	4-10b(3), F4-90, F4-91
Up Converter Module (1A1A13)	4-10b(3), F4-90, F4-91
First IF Selectivity Module (1A1A14)	4-10b(3), F4-90, F4-91
First IF Module (1A1A15)	4-10b(3), F4-90, F4-91
Second Mixer Module (1A1A16)	4-10b(3), F4-90, F4-91
Second IF Module (1A1A17)	4-10b(3), F4-90, F4-91
VFO Module (1A1A18)	4-10b(3), F4-90, F4-91
IF Selectivity Module (1A1A19)	4-10b(3), F4-90, F4-91
DC Control Module (1A1A20)	4-10b(3), F4-90, F4-91
Modulation/Squelch Module (1A1A21)	4-10b(3), F4-90, F4-91
IF Detector Module (1A1A22)	4-10b(3), F4-90, F4-91
Audio Module (1A1A23)	4-10b(3), F4-90, F4-91
Coupler Module (1A1A24)	4-10b(5), F4-90, F0-7
ALC Module (1A1A25)	4-10b(3), F4-90, F4-91
Bandswitch Assembly (1A1A26)	4-10b(7)
Detector Module (1A1A27)	4-10b(8), F4-90, F4-91, F0-7
Harmonic Filter Module (1A1A28)	4-10b(10), F4-90, F4-91, F0-7
PA Module (1A1A29)	4-10b(12), F4-90
Chassis Assembly (1A1A30)	4-10b(14)
Receiver/Exciter Parent Board (1A1A31)	4-10b(14)
Coupler Parent Board (1A1A32)	4-10b(14)
Quad Assembly (1A1A33)	4-10c, F4-90, F0-4, F0-5, F0-8
Repainting and Refinishing (Org)	2-2
Repair (DS)	4-9
Repair (Org)	2-7
Replacement	
Frequency Selector (1A1A1)	4-10b(2), F4-90
TR Relay Module (1A1A2)	4-10b(4), F4-90
IF Gain Module (1A1A3)	4-10b(4), F4-90
10V Power Supply Module (1A1A4)	4-10b(4), F4-90
-5V Power Supply Module (1A1A5)	4-10b(4), F4-90
Translator Module (1A1A6)	4-10b(4), F4-90
Upper Loop Divider Module (1A1A7)	4-10b(4), F4-90
Phase Detector Module (1A1A8)	4-10b(4), F4-90
Lower Loop Module (1A1A9)	4-10b(4), F4-90
Oscillator Distributor Module (1A1A10)	4-10b(4), F4-90
Digital Divider Module (1A1A11)	4-10b(4), F4-90
Transmit Broadband Module (1A1A12)	4-10b(4), F4-90
Up Converter Module (1A1A13)	4-10b(4), F4-90
First IF Selectivity Module (1A1A14)	4-10b(4), F4-90
First IF Module (1A1A15)	4-10b(4), F4-90
Second Mixer Module (1A1A16)	4-10b(4), F4-90
Second IF Module (1A1A17)	4-10b(4), F4-90
VFO Module (1A1A18)	4-10b(4), F4-90
IF Selectivity Module (1A1A19)	4-10b(4), F4-90

Subject	Paragraph, Figure, or Table Number
Replacement (Cont.)	
DC Control Module (1A1A20)	4-10b(4), F4-90
Modulation/Squelch Module (1A1A21).....	4-10b(4), F4-90
IF Detect Module (1A1A22)	4-10b(4), F4-90
Audio Module (1A1A23).....	4-10b(4), F4-90
Coupler Module (1A1A24).....	4-10b(6), F4-90
ALC Module (1A1A25).	4-10b(4), F4-90
Bandswitch Assembly (1A1A26).....	4-10b(7)
Detector Module (1A1A27)	4-10b(9), F4-90 FO-7
Harmonic Filter Module (1A1A28)	4-10b(11), F4-90
PA Module (1A1A29)	4-10b(13), F4-90
Chassis Assembly (1A1A30).....	4-10b(14)
Receiver/ Exciter Parent Board (1A1A31)	4-10b(14)
Coupler Parent Board (1A1A32)	4-10b(14)
Quad Assembly (1A1A33)	4-10b(16), F4-90
Reporting Equipment Improvement Recommendations	1-7
RT Unit (1A1)	
Simplified Block Diagram Analysis.....	3-2, FO-1
Detailed Block Diagram Analysis.....	3-3, FO-2
PMCS	2-3
Removal and Replacement (Org)	2-6, F2-1
Troubleshooting (Org).....	2-4
Troubleshooting (DS)	4-3
Receive Functional Troubleshooting Tests	4-6, T4-4
Mode RCV	4-6c, F4-26, F4-27, F4-28
Narrow Band Audio.....	4-6f, F4-92, F4-43, F4-44
Receive AGC	4-6e, F4-39, F4-40, F4-41
Receive FSK/CW.....	F-6i, F4-49
Receive SINAD... ..	4-6j, F4-23, F4-50, F4-51, T4-5
Receive Signal Path.....	4-6d, F4-29, F4-30, F4-31, F4-32, F4-33, F4-34, F4-35, F4-36, F4-37, F4-38, FO-2, FO-11, FO-12
Receive Synthesizer	4-6b, F4-12, F4-13, F4-14, F4-15, F4-16, F4-17, F4-18, F4-19, F4-20, F4-21, F4-22, F4-23, F4-24, F4-25, T4-5
Receive Wide Band Audio	4-6h, F4-48
Squelch/Retransmit	4-6g, F4-45, F4-46, F4-47
Voltage Distribution	4-6a, F4-9, F4-10, F4-11, FO-9
Transmit Functional Troubleshooting Tests	4-7, T4-6
NB FM Transmit Audio Test	4-7g, F4-78, F4-79, F4-80

Subject	Paragraph, Figure, or Table Number
Transmit Functional Troubleshooting Tests (Cont.)	
No-Tune Tone detests	4-7e, F4-72, F4-73, F4-74, FO-12
Sidetone Test	4-7f, F4-75, F4-76, F4-77
Transmit Audio Signal Path Test	4-7d, F4-68, F4-69, F4-70, F4-71
Transmit CW/FSK Troubleshooting Test	4-7h, F4-81, F4-82, F4-83
Transmit IF Signal Path Test	4-7c, F4-63, F4-64, F4-65, F4-66, F4-67, FO-11
Transmit Power Output Test	4-7i, F4-84, F4-85, F4-86, F4-87, F4-88, F4-89
Transmit RF Signal Path Test	4-7b, F4-57, F4-58, F4-59, F4-60, F4-60.1, F4-61, F4-62, F4-62.1
Transmit Subgroup Isolation Test	4-7a, F4-52, F4-53, F4-54, F4-55, F4-56
Maintenance (Org)	2-5
Maintenance, Additional	4-14, FO-4
Test Procedures	4-11
Scope	1-1
Second IF Module (1A1A17)	
Functional Analysis	3-20, F3-16
Removal	4-10b(3), F4-90, F4-91
Replacement	4-10b(4), F4-90
Second Mixer Module (1A1A16)	
Functional Analysis	3-19, F3-15
Removal	4-10b(3), F4-90, F4-91
Replacement	4-10b(4), F4-90
Simplified Block Diagram Analysis	3-2, FO-1
Storage, Administrative	1-5
Tabular Data	1-11
Testing After Repair	2-8
Tools and Test Equipment (DO)	4-2, T4-1
Tools and Test Equipment (Org)	2-1
Translator Module (1A1A6)	
Functional Analysis	3-9, F3-5
Removal	4-10b(3), F4-90, F4-91
Replacement	4-10b(4), F4-90
Transmit Broadband Module (1A1A12)	
Functional Analysis	3-15, F3-11
Removal	4-10b(3), F4-90, F4-91
Replacement	4-10b(4), F4-90
Troubleshooting Procedure (DS)	4-4, F4-1

Subject	Paragraph, Figure, or Table Number
Troubleshooting Procedure (Org)	2-4
TR Relay Module (1A1A2)	
Functional Analysis	3-5, F3-1
Removal	4-10b(3), F4-90, F4-91
Replacement	4-10b(4), F4-90
Up Converter Module (1A1A13)	
Functional Analysis	3-16, F3-12
Removal	4-10b(3), F4-90, F4-91
Replacement	4-10b(4), F4-90
Upper Loop Divider Module (1A1A7)	
Functional Analysis	3-10, F3-6
Removal	4-10b(3), F4-90, F4-91
Replacement	4-10b(4), F4-90
VFO Module (1A1A18)	
Functional Analysis	3-21, F3-17
Removal	4-10b(3), F4-90, F4-91
Replacement	4-10b(4), F4-90
Warranty Information	1-8
-5V Power Supply Module (1A1A5)	
Functional Analysis	3-8
Removal	4-10b(3)
Replacement	4-10b(4)
10V Power Supply Module (1A1A4)	
Functional Analysis	3-7
Removal	4-10b(3)
Replacement	4-10b(4)

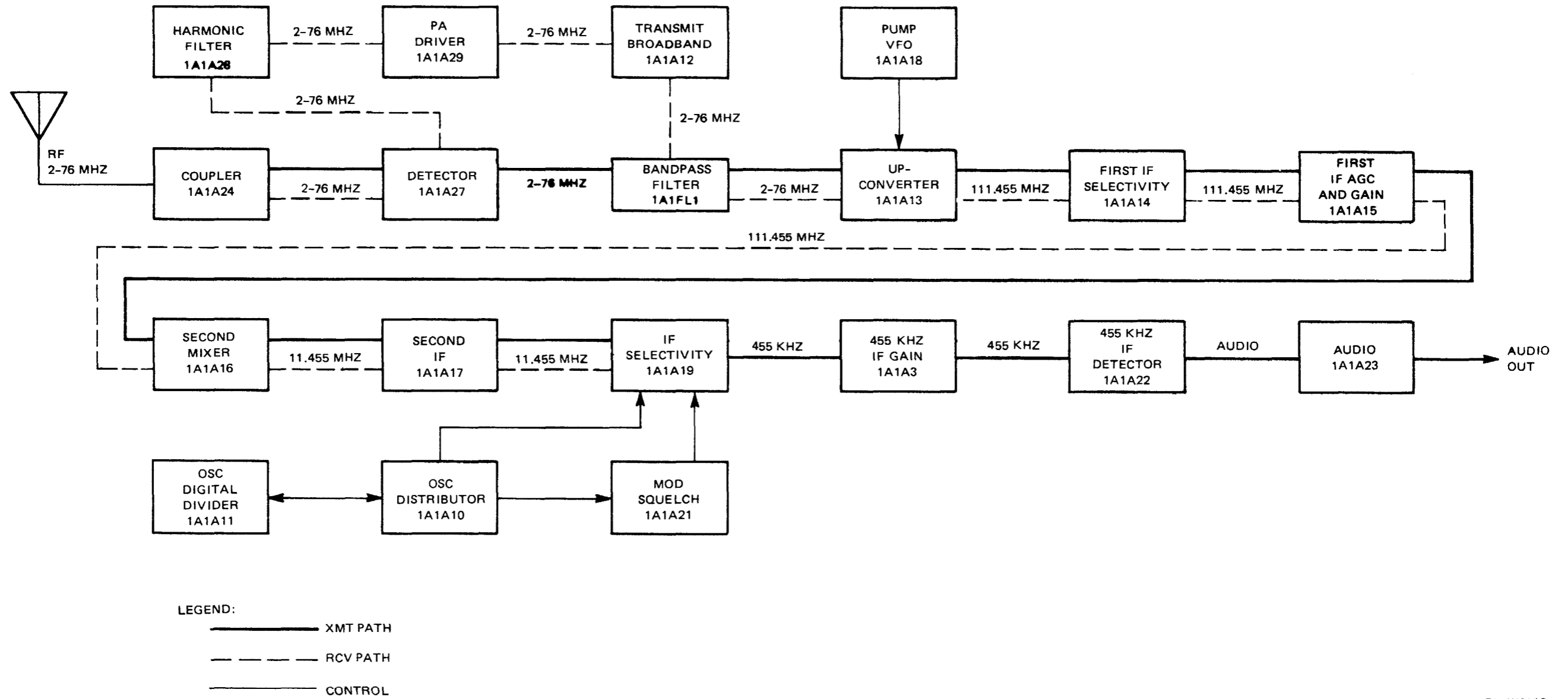

Figure FO-1. RT unit, simplified block diagram.

EL EWS110

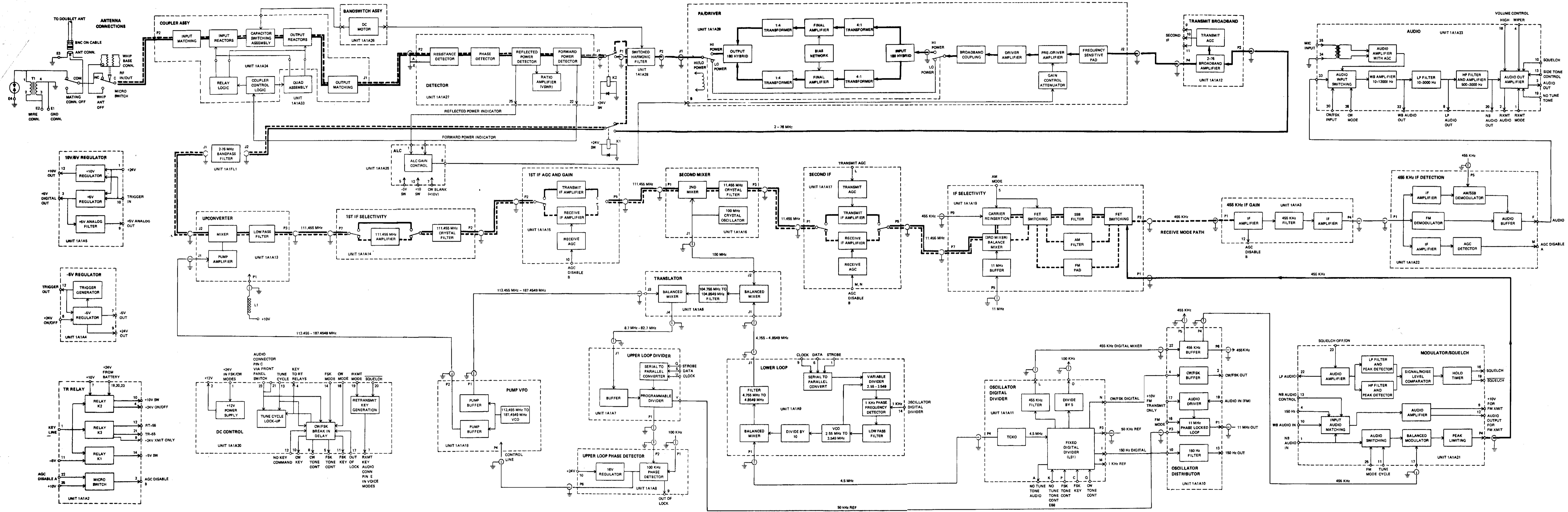

Figure PO-2. RT unit, detailed block diagram.

Figure PO-2

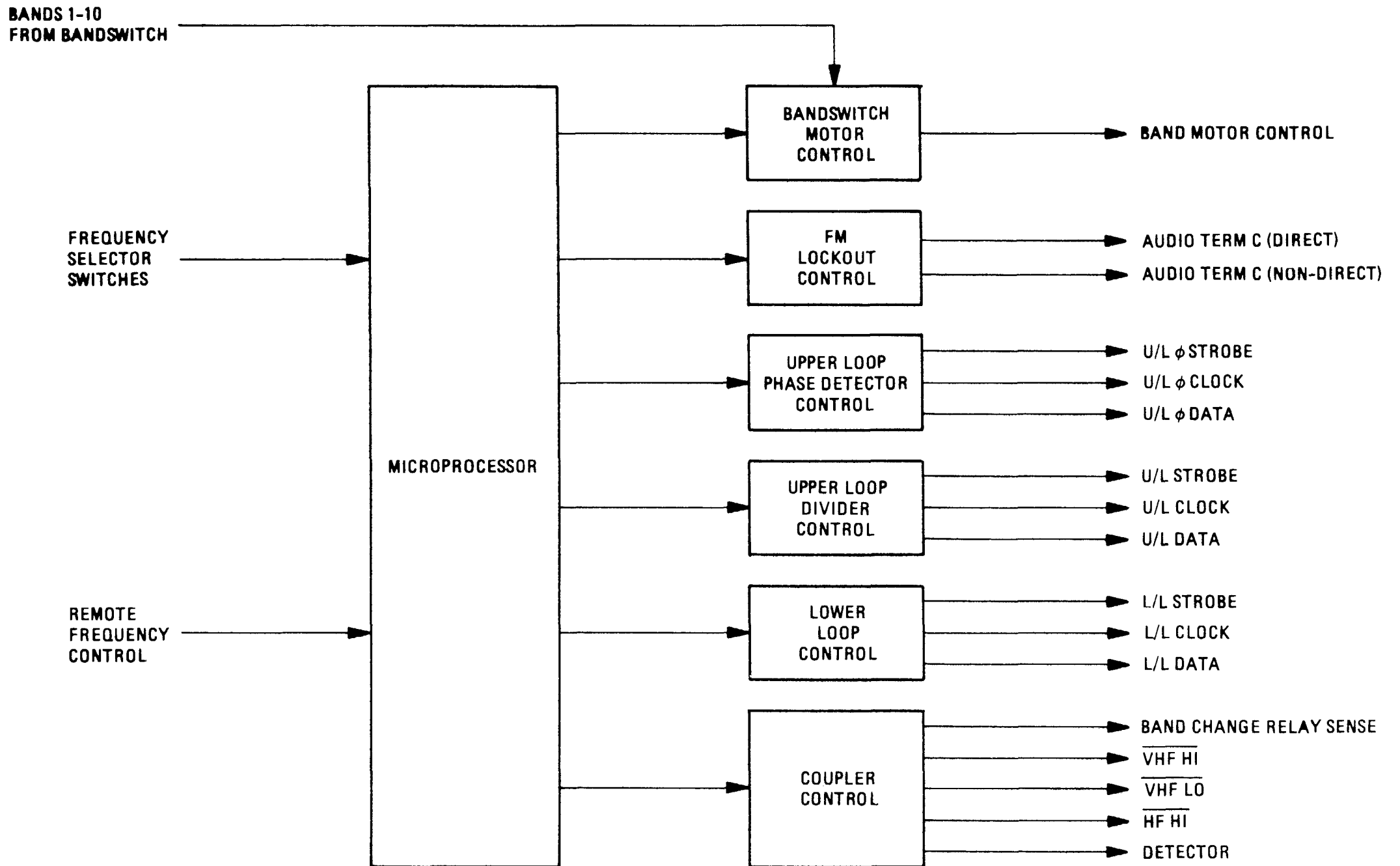

Figure FO-3. Frequency selector 1A1A1, block diagram.

EL5WS031

AUDIO

A	GND
B	RCV AUDIO
C	KEY LINE
D	MIC IN
E	REMOTE KEY

RETRANS

A	GND
B	RXMT AUDIO
C	KEY LINE
D	MIC IN
E	REMOTE KEY

X-MODE

A	GND(MIC)
B	AUDIO
C	KEY LINE
D	MIC IN
E	+24V OUT
F	+24V IN
H	FREQ SEL-DATA
J	GND(DC)
K	RXMT KEY
L	NB AUDIO
M	FREQ SEL-CLK
N	+24V XMT ONLY
P	WB AUDIO OUT
R	WB AUDIO IN

POWER

PIN 5	+24V
PIN 1	GND

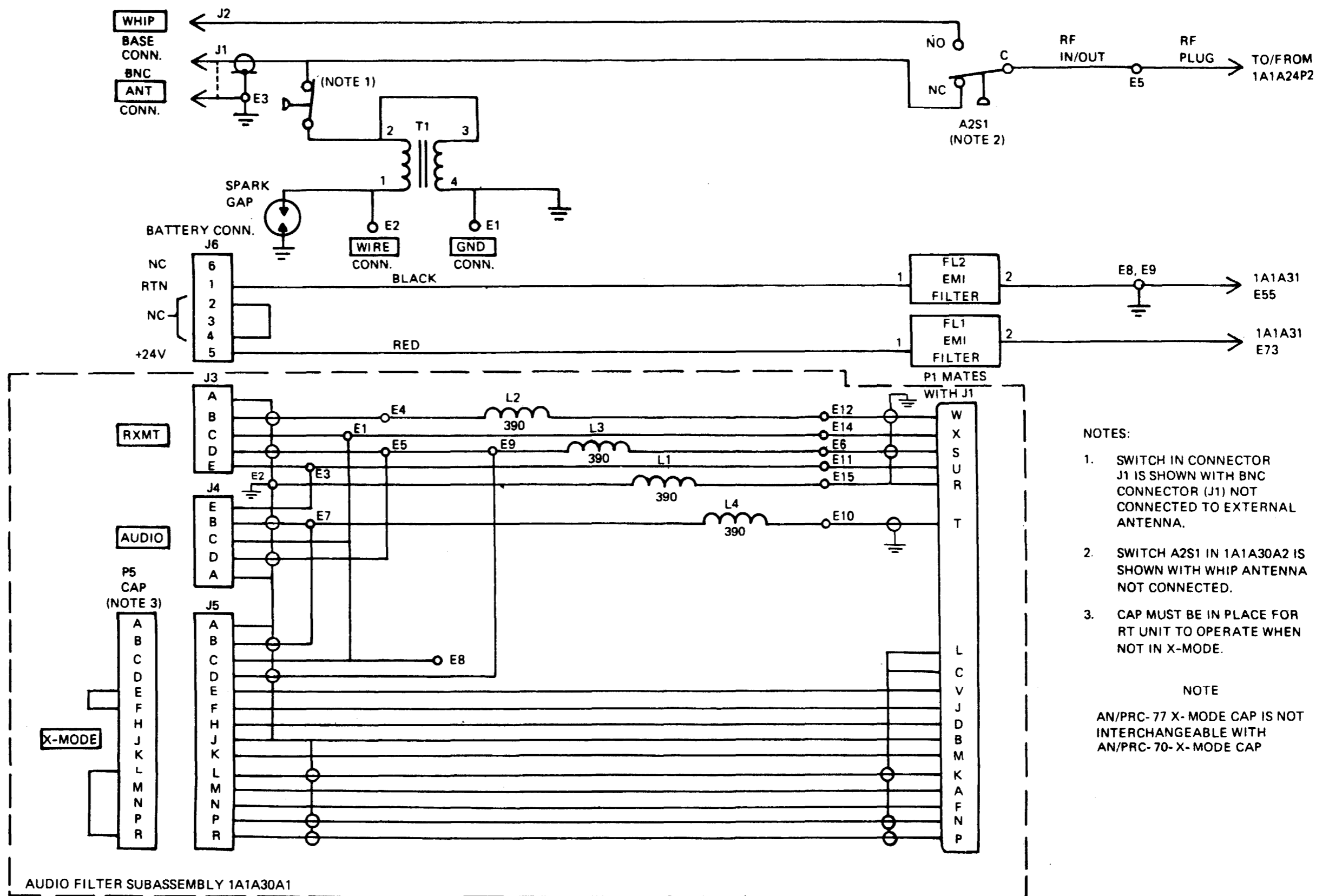

- NOTES:**
- SWITCH IN CONNECTOR J1 IS SHOWN WITH BNC CONNECTOR (J1) NOT CONNECTED TO EXTERNAL ANTENNA.
 - SWITCH A2S1 IN 1A1A30A2 IS SHOWN WITH WHIP ANTENNA NOT CONNECTED.
 - CAP MUST BE IN PLACE FOR RT UNIT TO OPERATE WHEN NOT IN X-MODE.
- NOTE**
- AN/PRC-77 X-MODE CAP IS NOT INTERCHANGEABLE WITH AN/PRC-70- X-MODE CAP

Figure FO-4. Case assembly 1A1A30, interconnection diagram.

TYPICAL PIN LOCATIONS

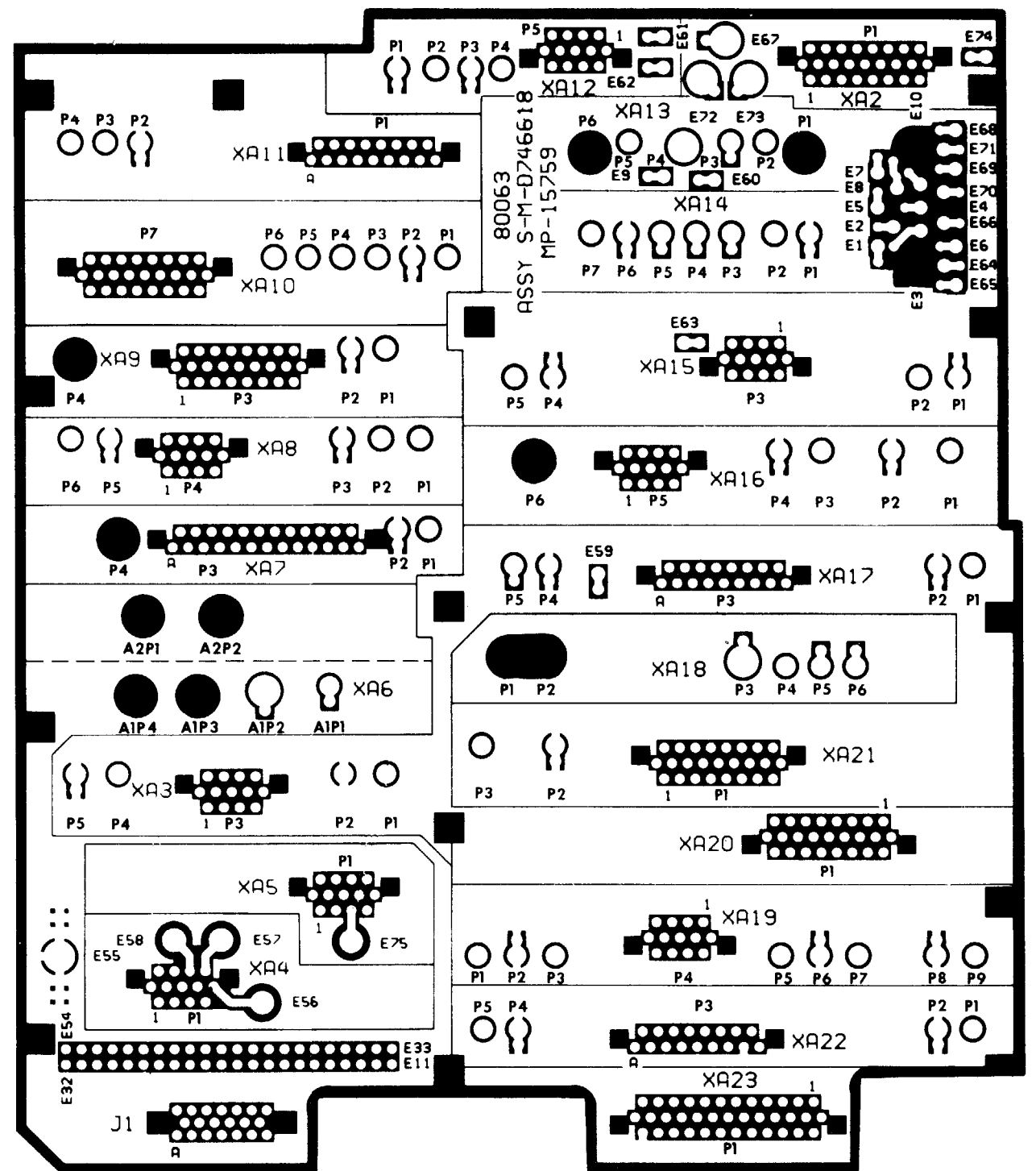
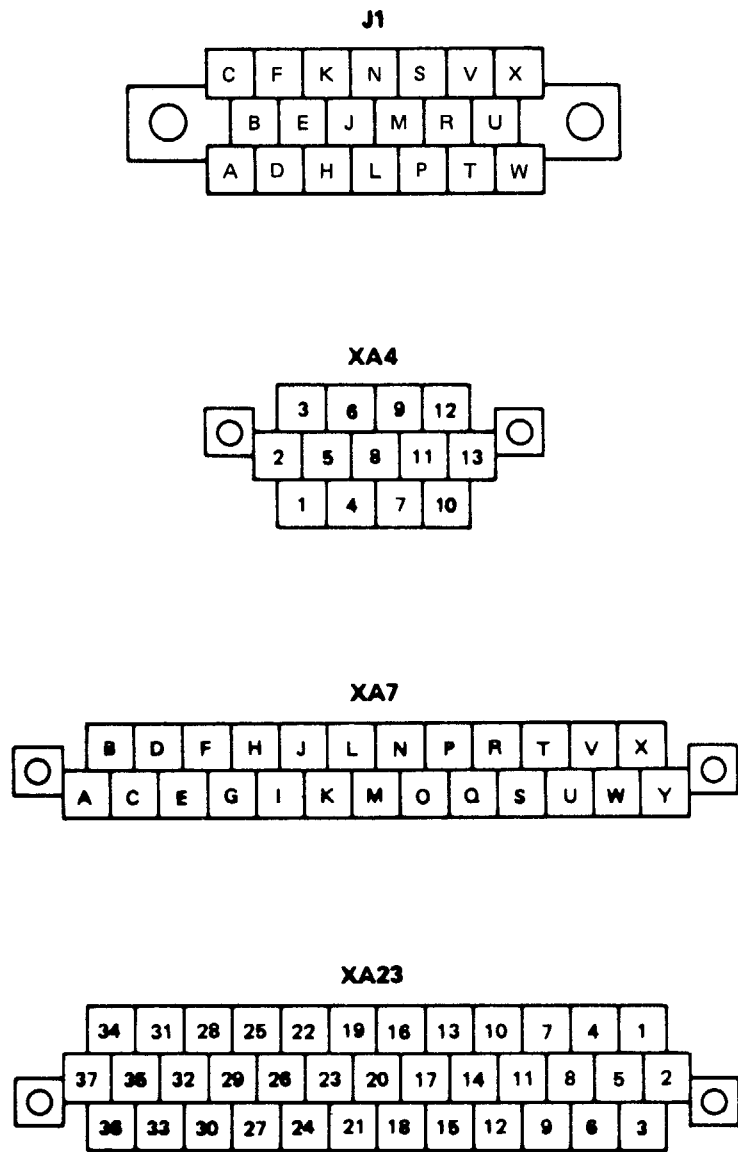

Figure FO-5. Receiver exciter parent board 1A1A31, interconnection diagram (sheet 1 of 5).

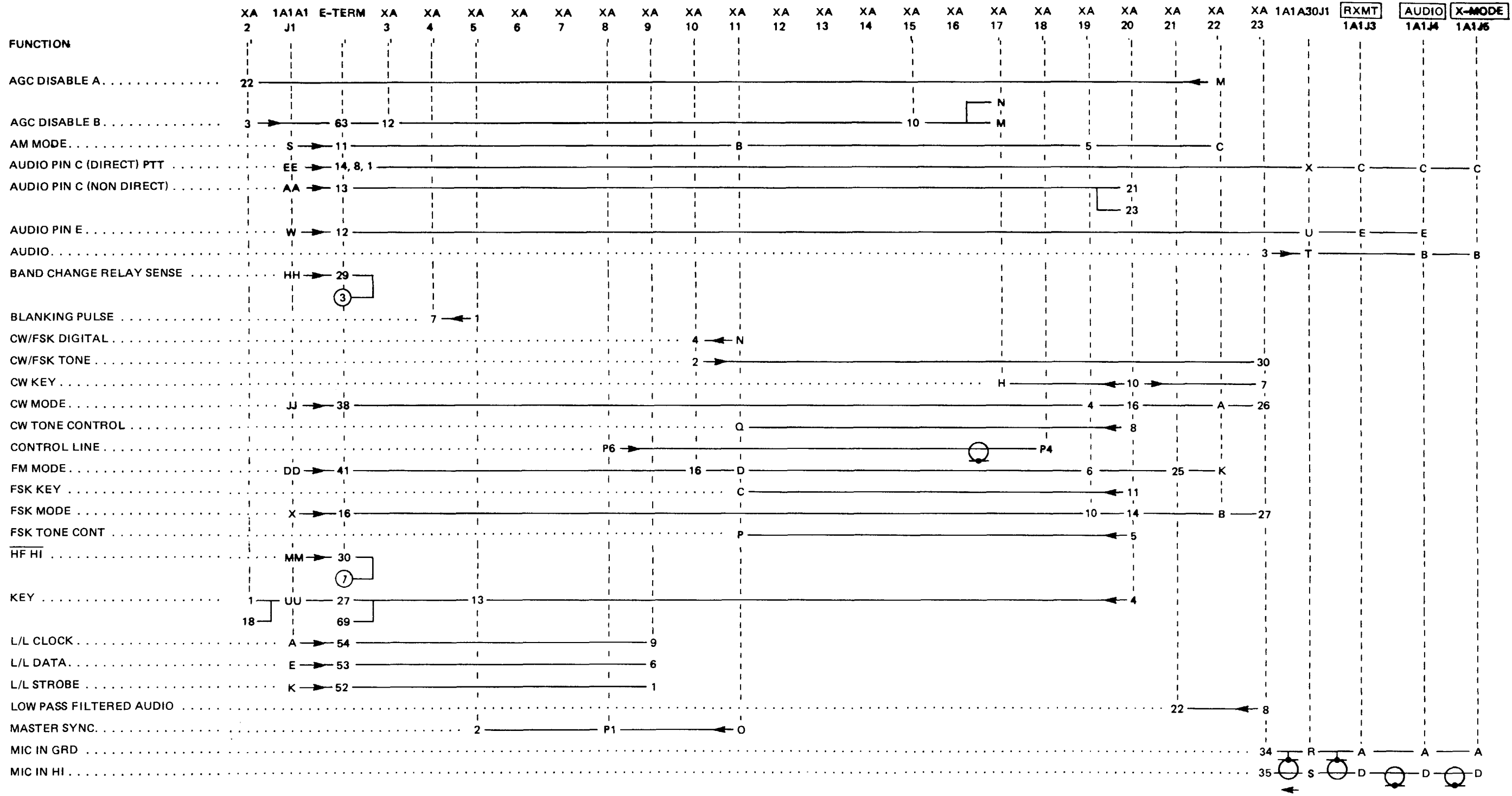

Figure FO-5. Receiver exciter parent board 1A1A31, interconnection diagram (sheet 2 of 5).

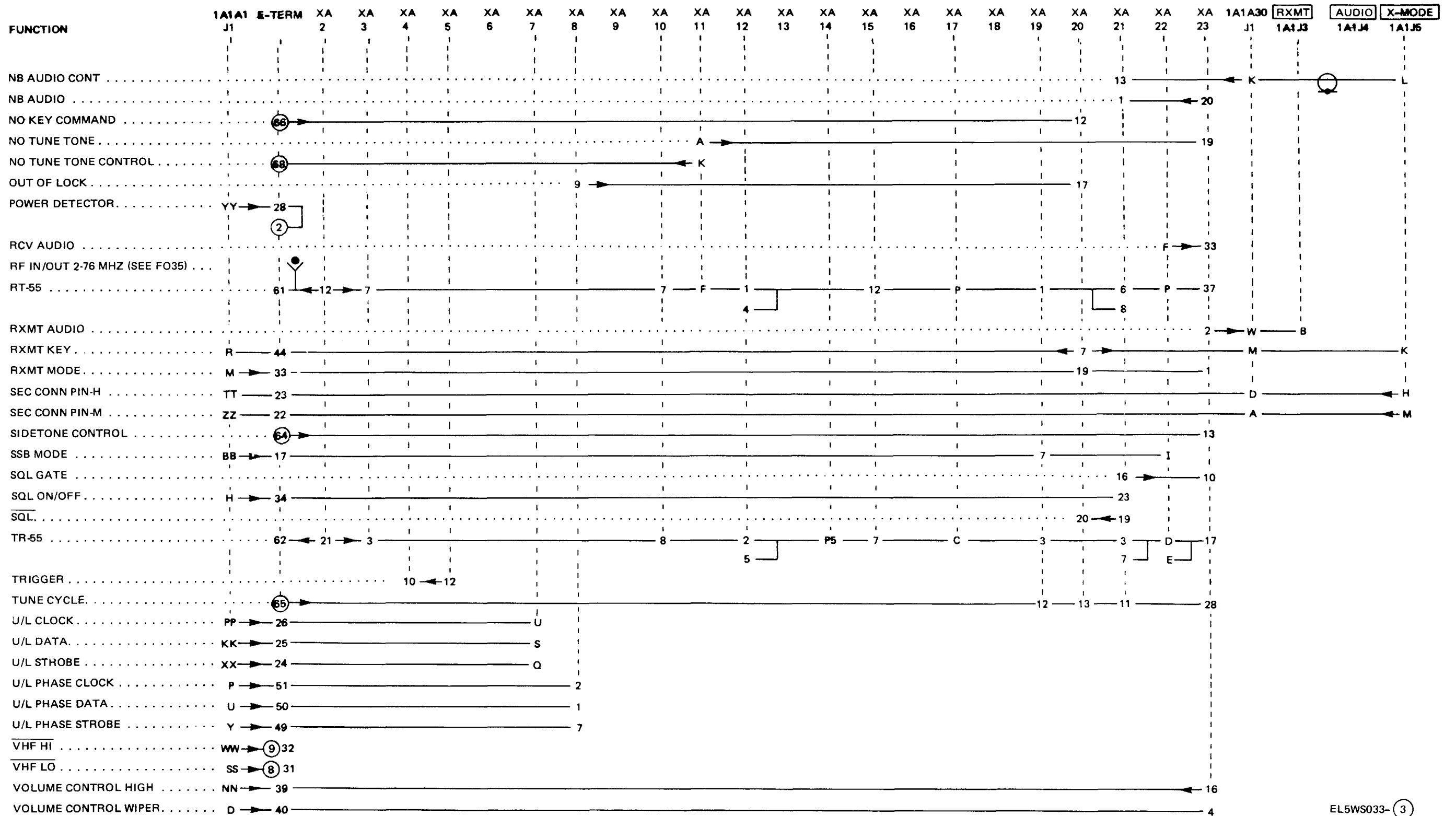

Figure F0-5. Receiver exciter parent board 1A1A31, interconnection diagram (sheet 3 of 5).

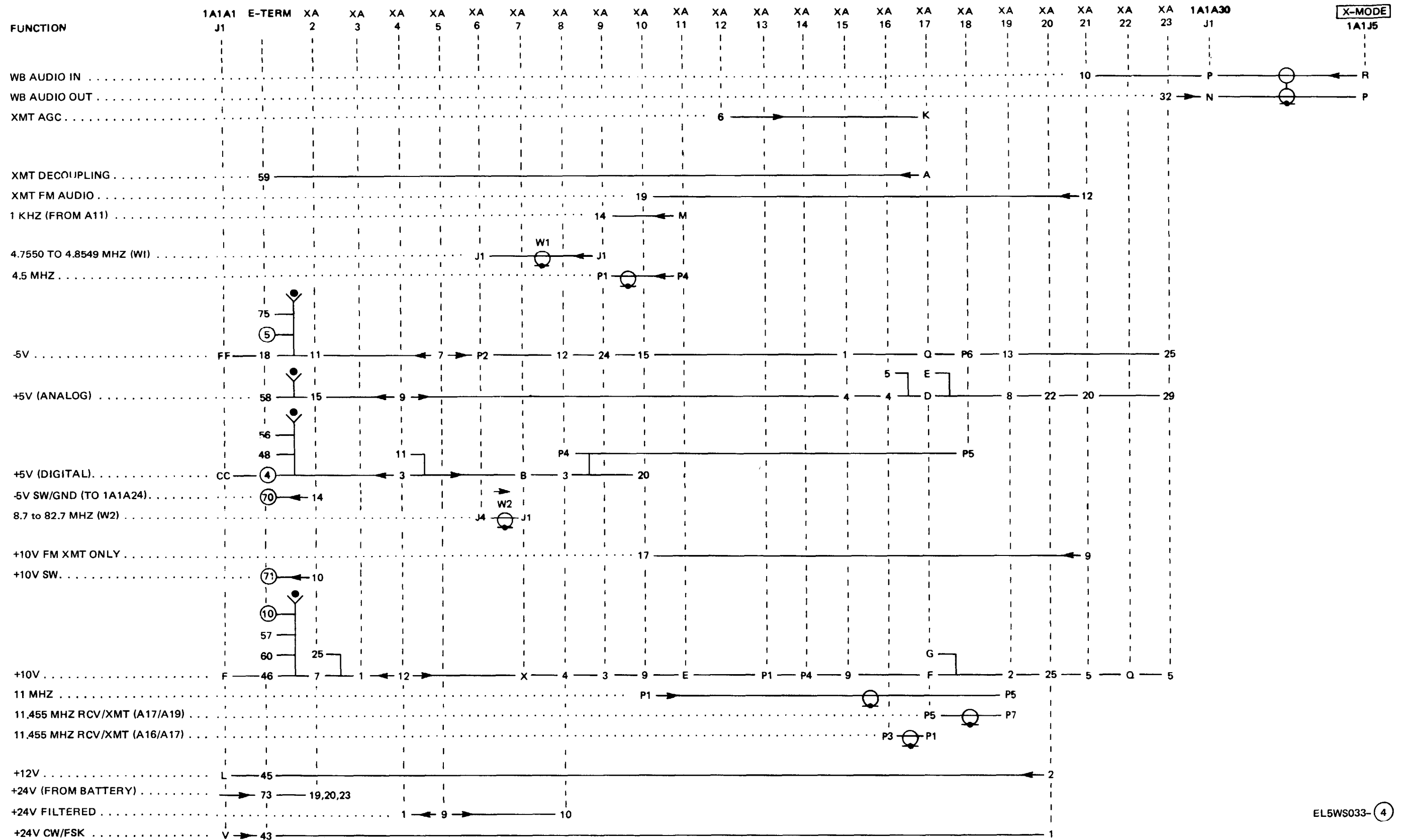
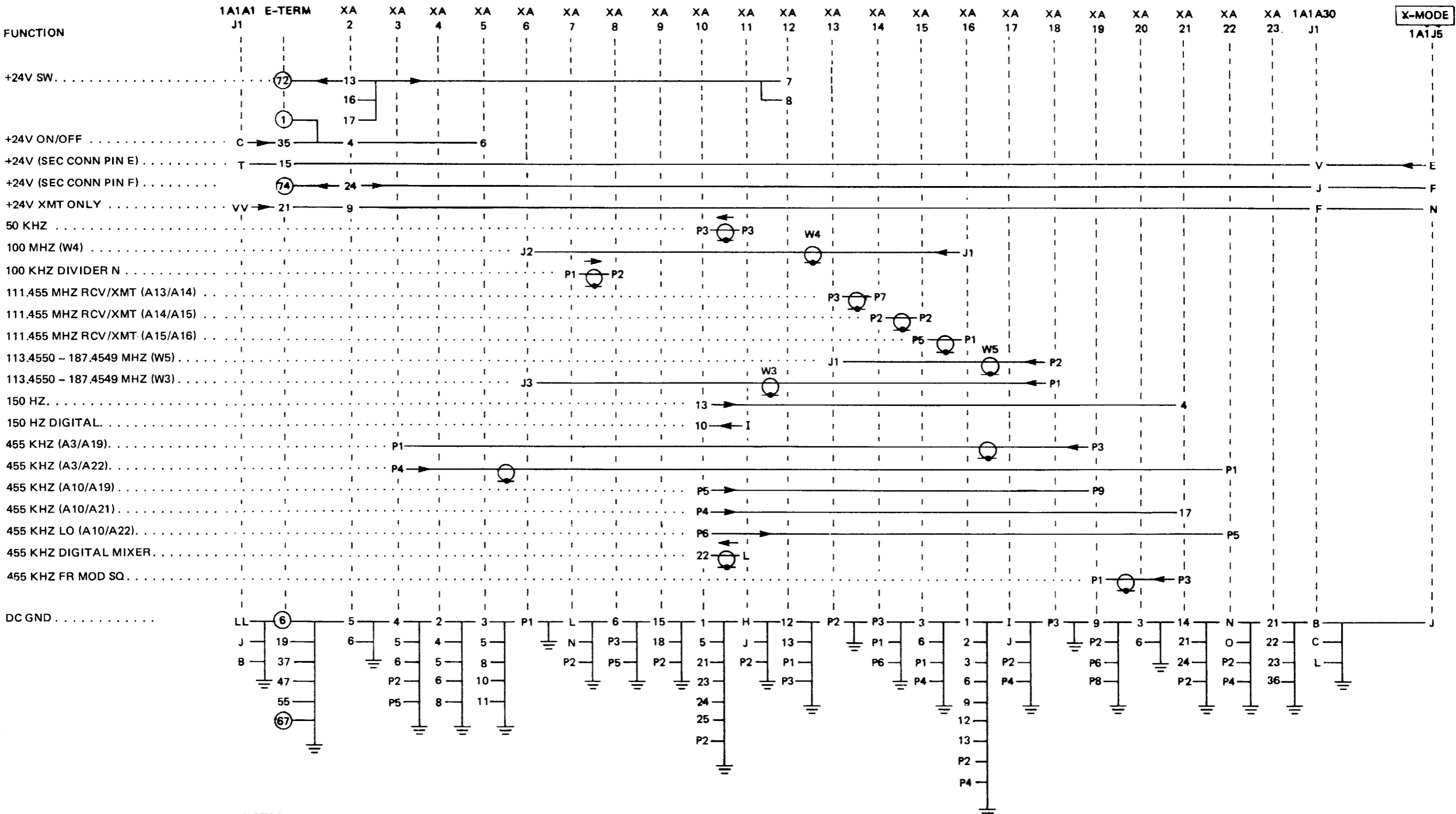

Figure FO-5. Receiver exciter parent board 1A1A31, interconnection diagram (sheet 4 of 5).



- NOTES:
1. PROTECTING CABLE SHEATHS () ARE CONNECTED TO GROUND ().
 2.  INDICATES CONNECTION TO PA COUPLER PARENT BOARD.

Figure FO-5. Receiver exciter parent board 1A1A31, interconnection diagram (sheet 5 of 5).

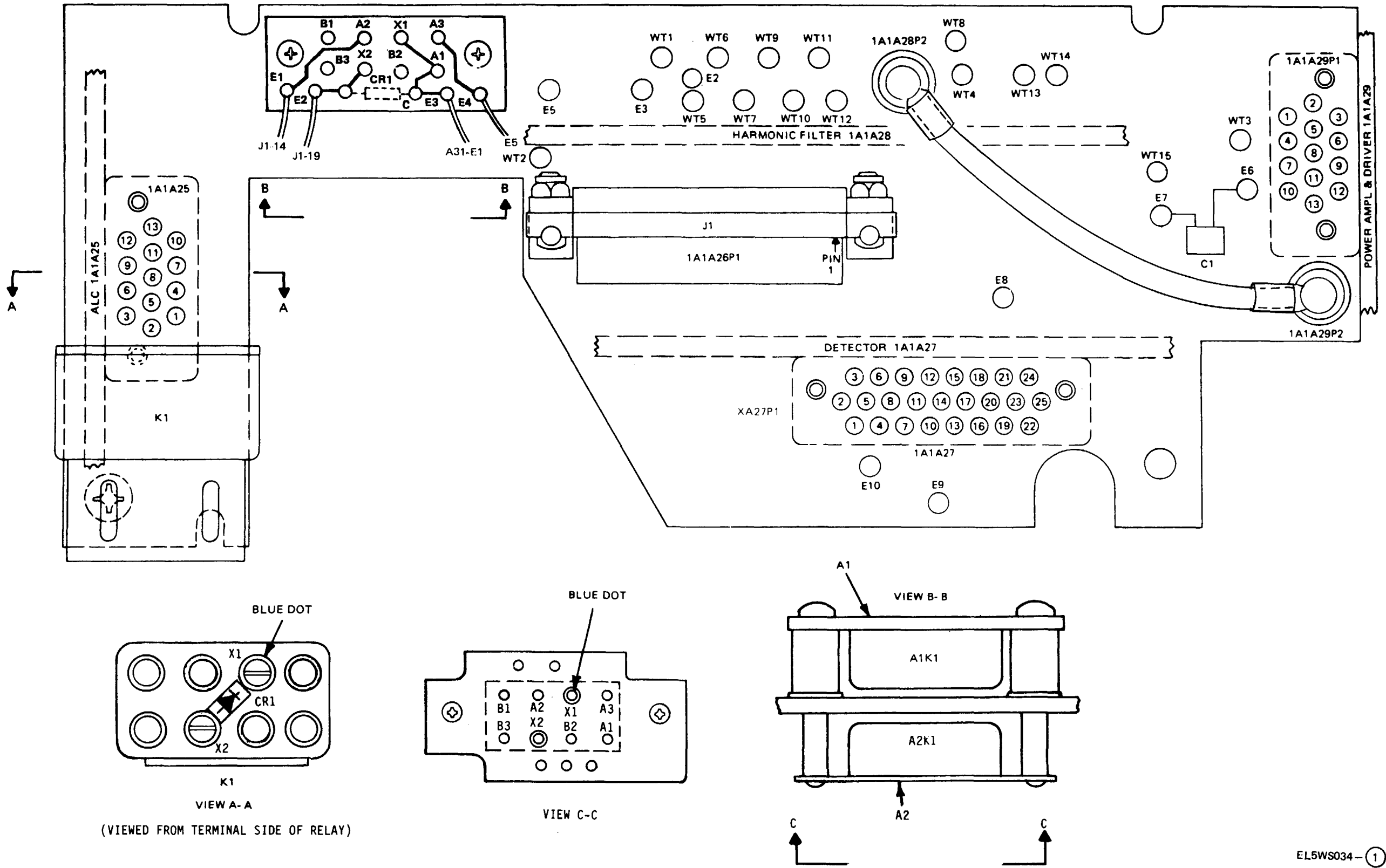
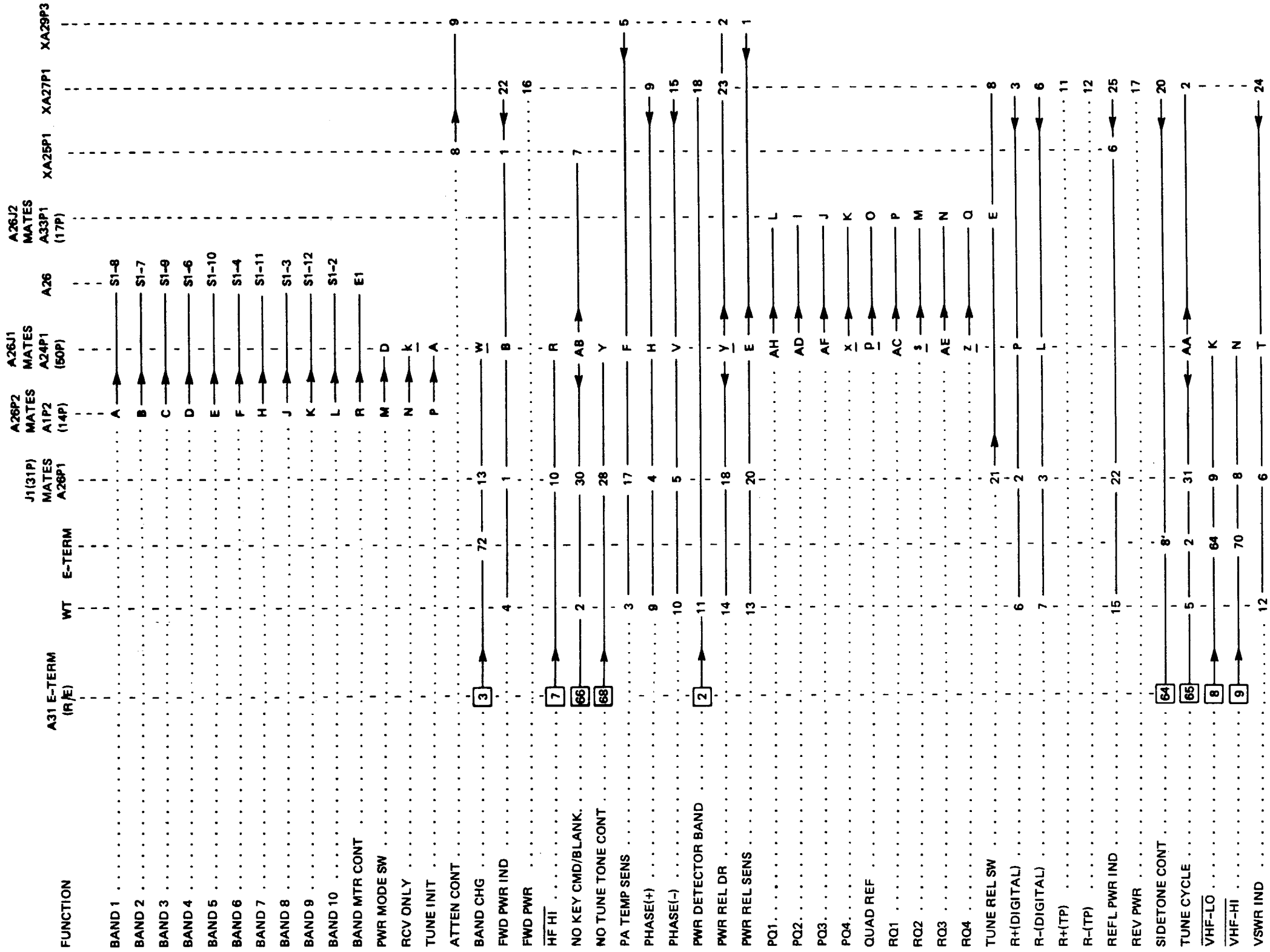

Figure FO-6. Power amplifier coupler parent board 1A1A32, interconnection diagram (sheet 1 of 3).

EL5WS034-①



NOTES:

1. PROTECTING CABLE SHEATHS ARE CONNECTED TO GROUND.
2. BOXED IN NUMBERS [XX] INDICATE CONNECTORS BETWEEN PA AND R/E PARENT BOARDS.

Figure FO-6. Power amplifier coupler parent board 1A1A32, interconnection diagram (sheet 2 of 3).

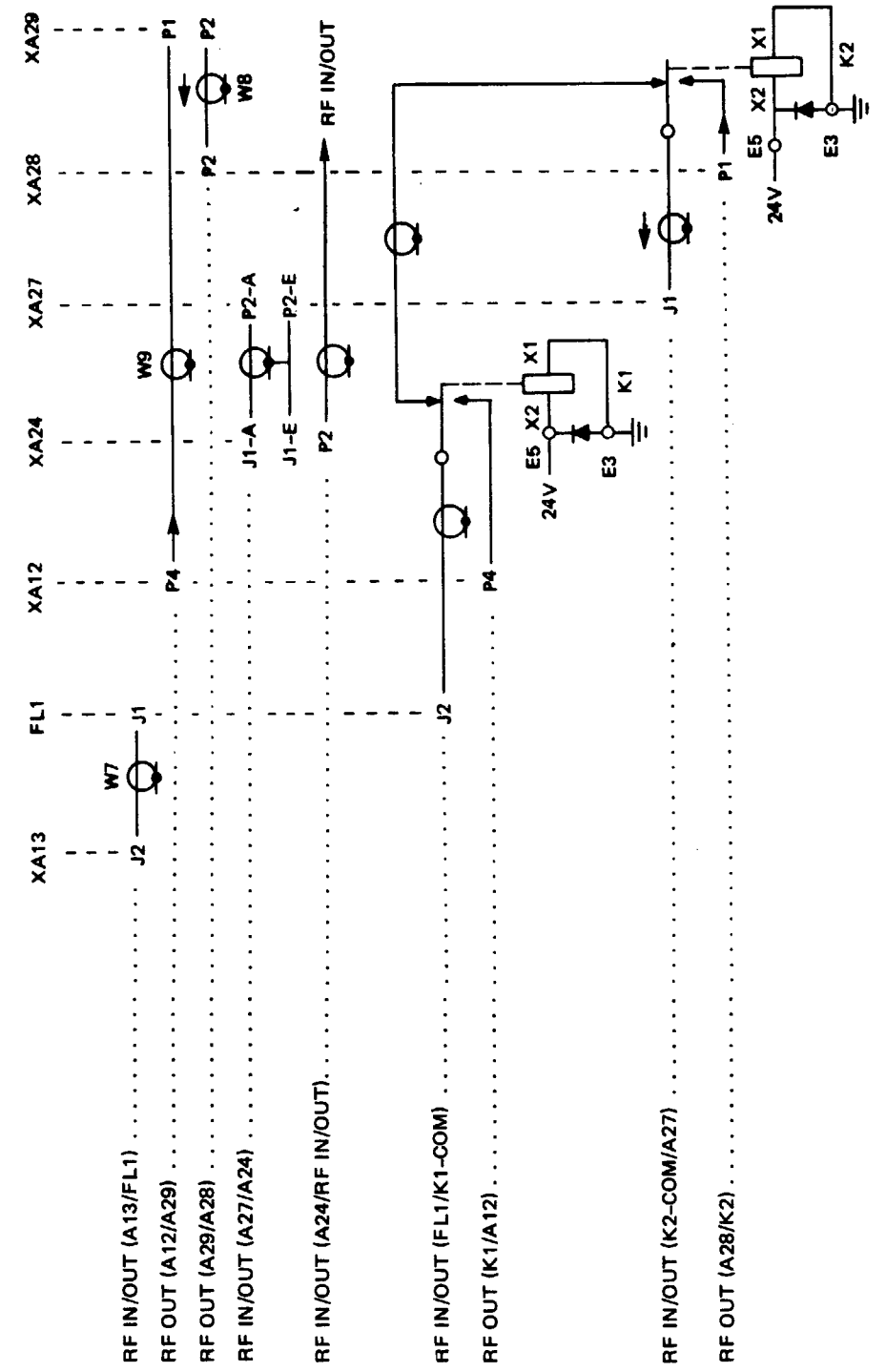
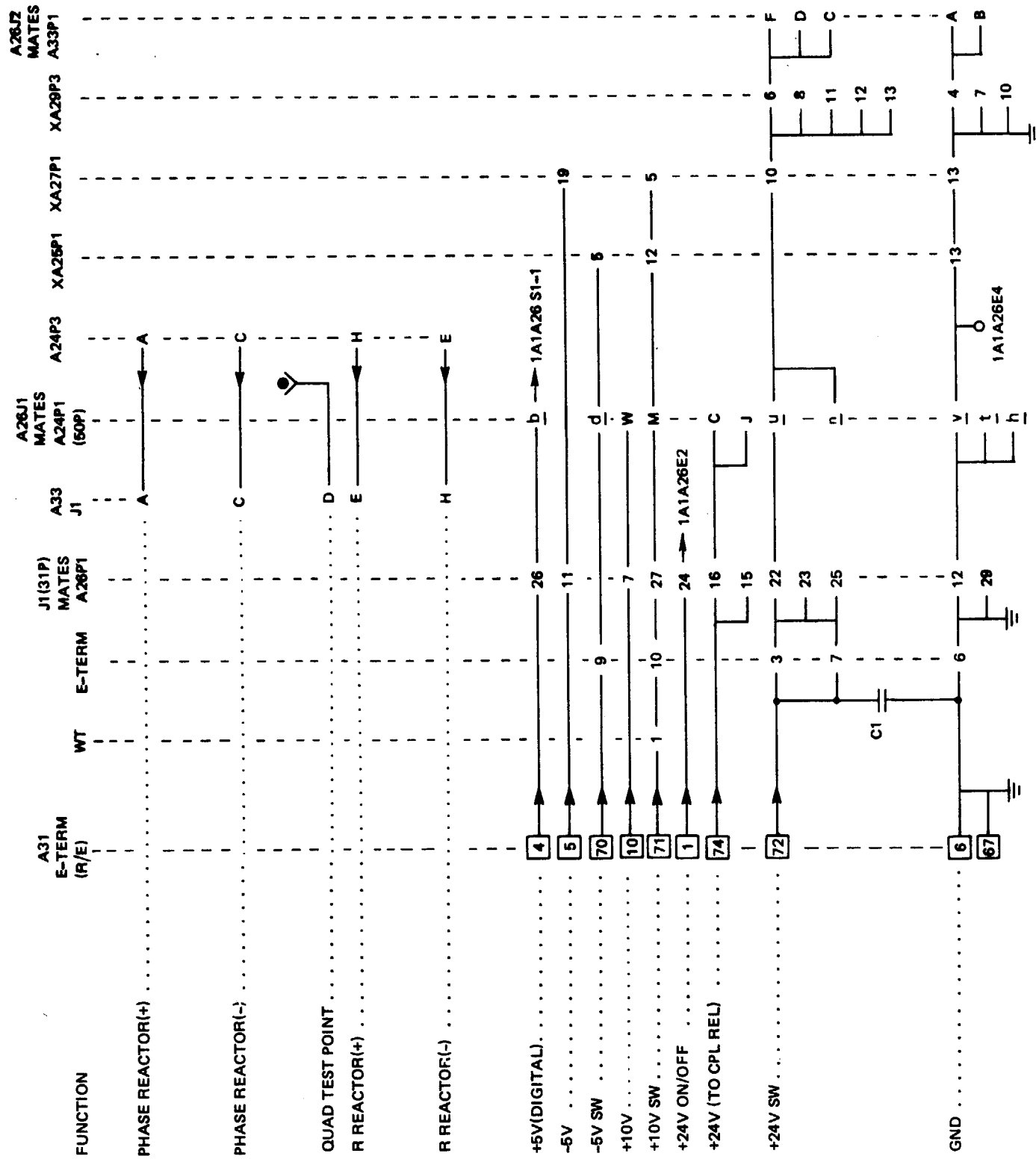

Figure FO-6. Power amplifier coupler parent board 1A1A32, interconnection diagram (sheet 3 of 3).

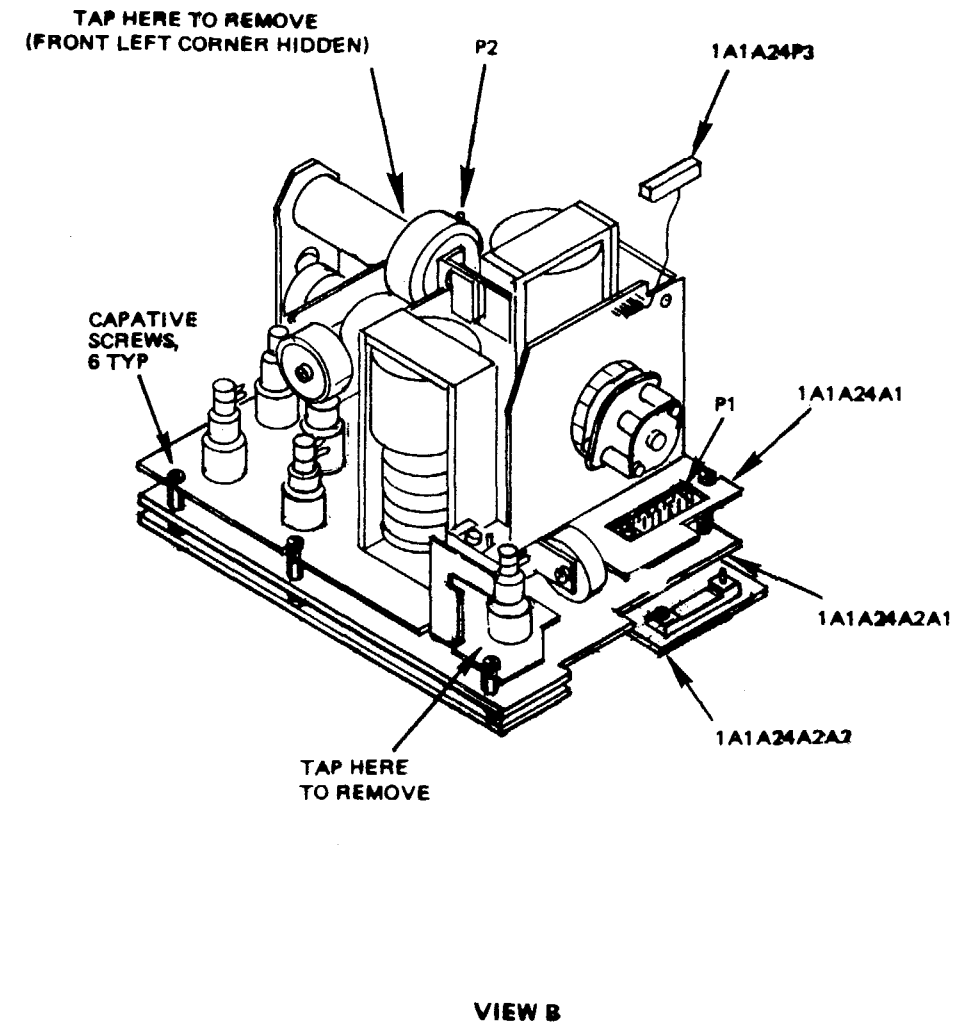
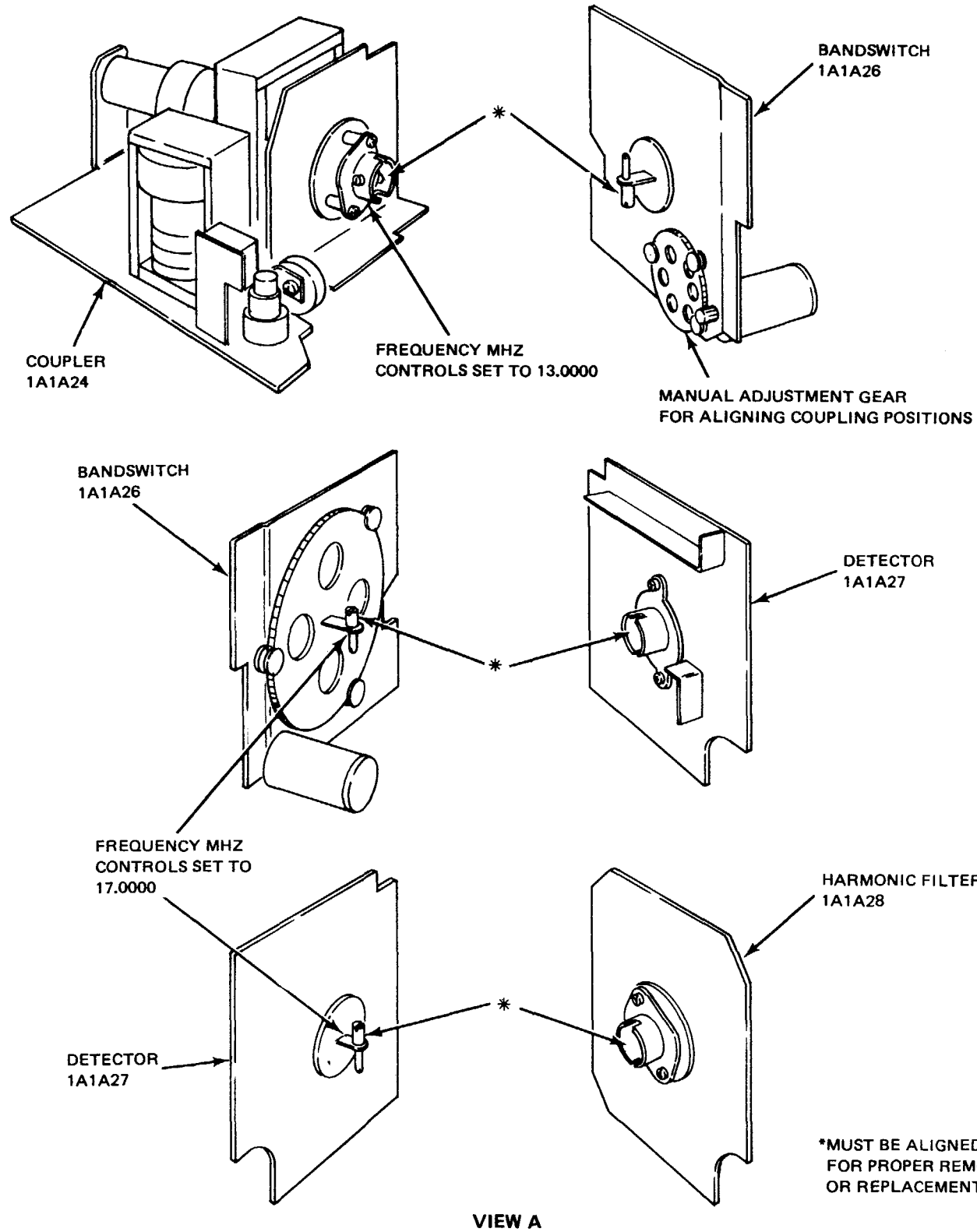
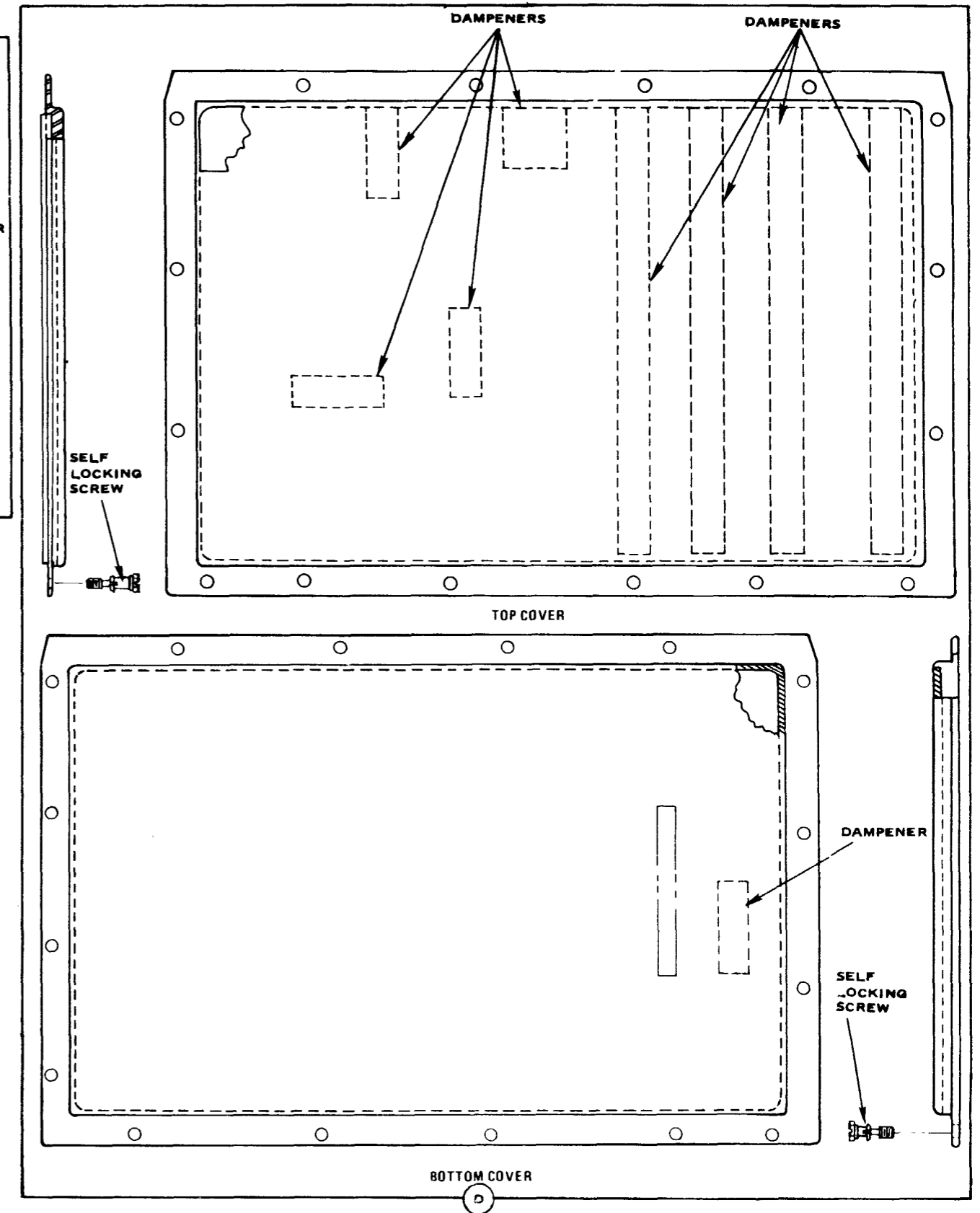
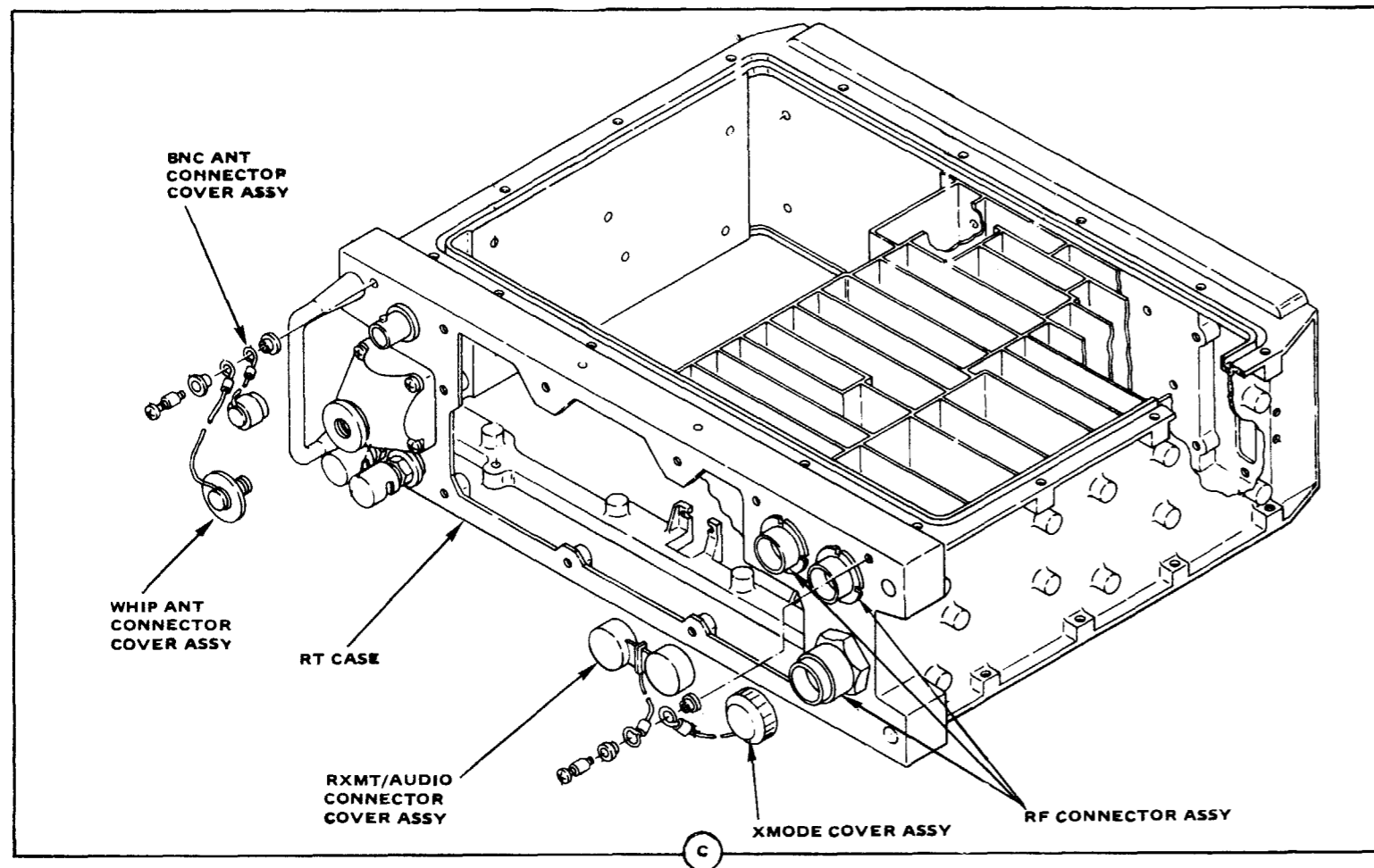
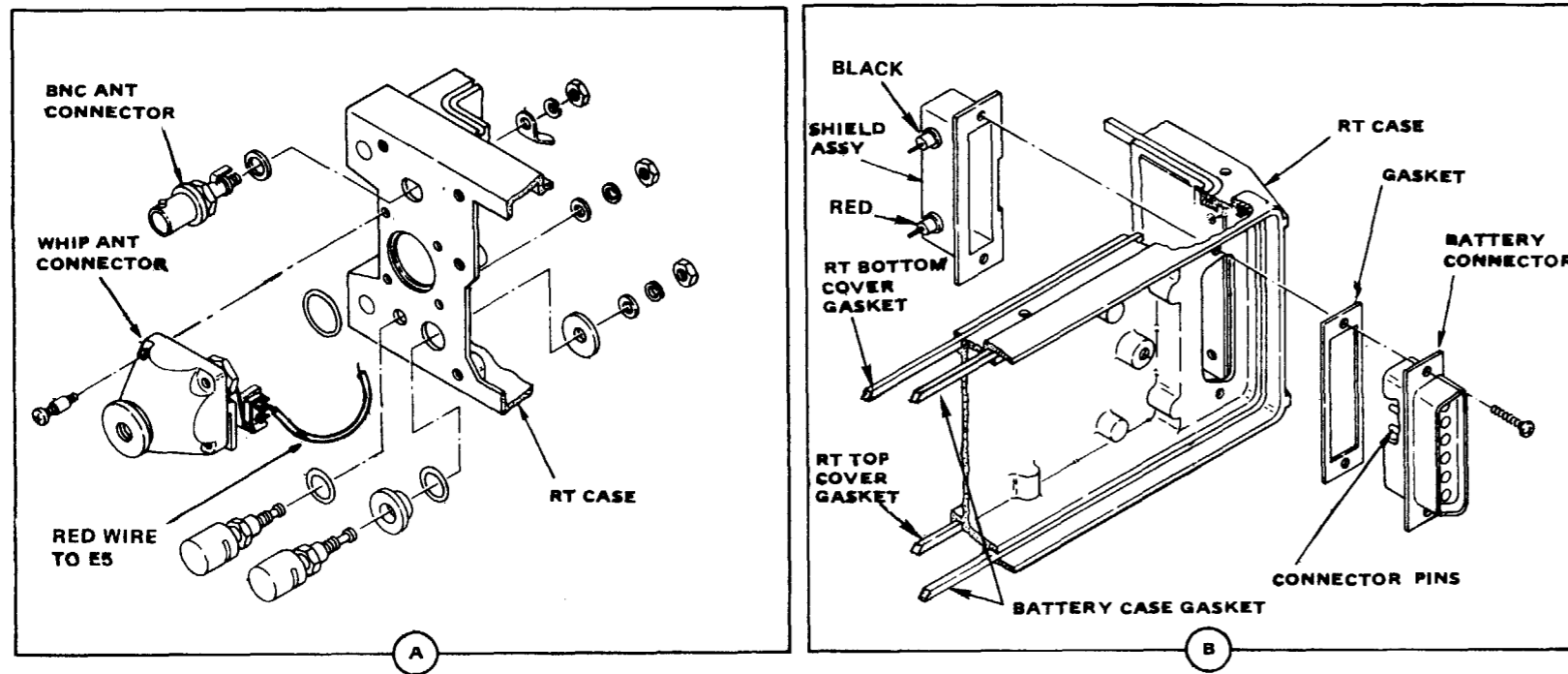

Figure FO-7. Modules 1A1A24, 1A1A26, 1A1A27, and 1A1A28, removal and replacement diagram.



EL5WS139

Figure FO-8. Receiver-transmitter case, replaceable parts.

Figure FO-14

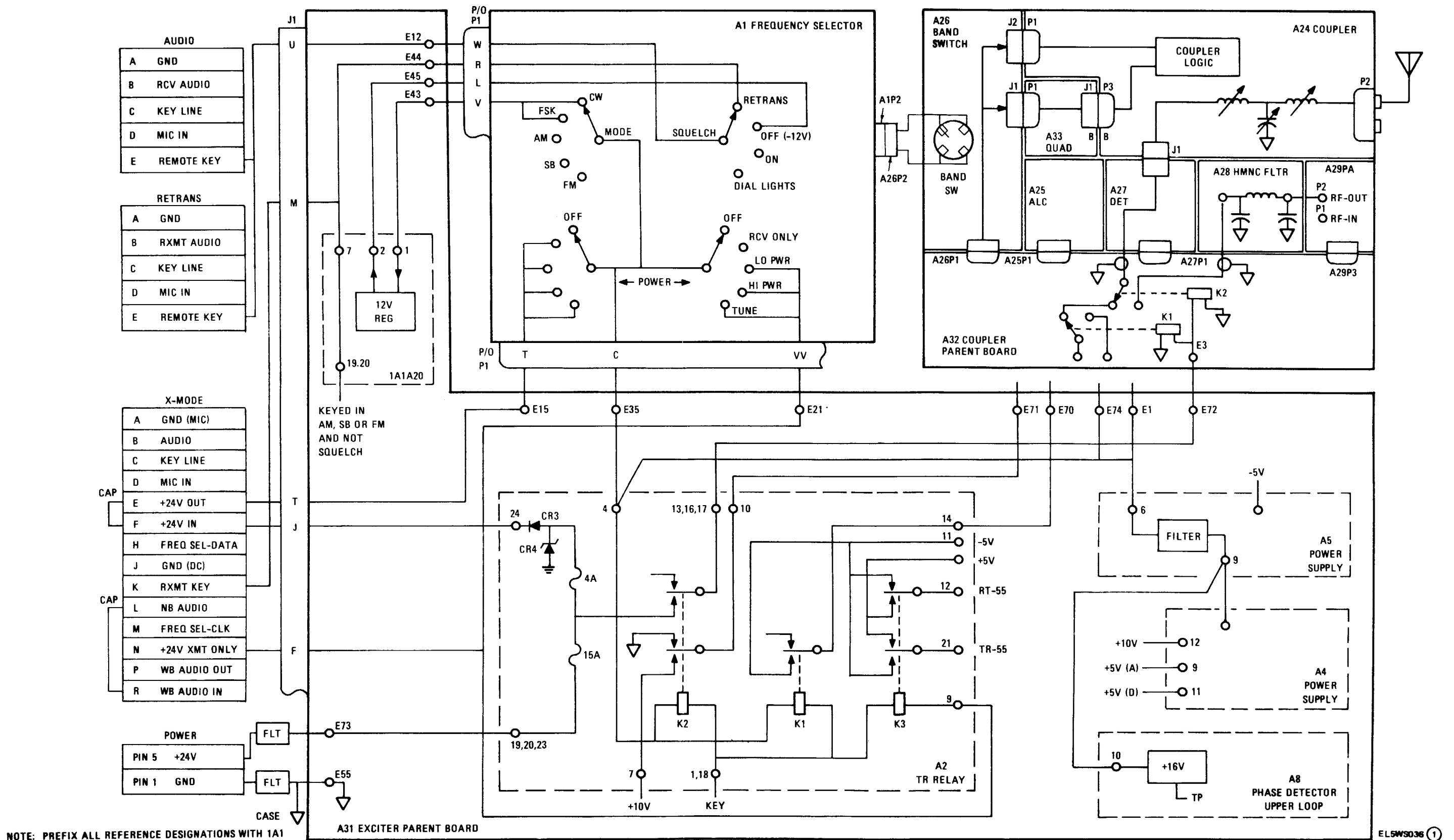

NOTE: PREFIX ALL REFERENCE DESIGNATIONS WITH 1A1

EL5WS036 ①

Figure FO-9. Voltage distribution detailed block diagram (Sheet 1 of 2).

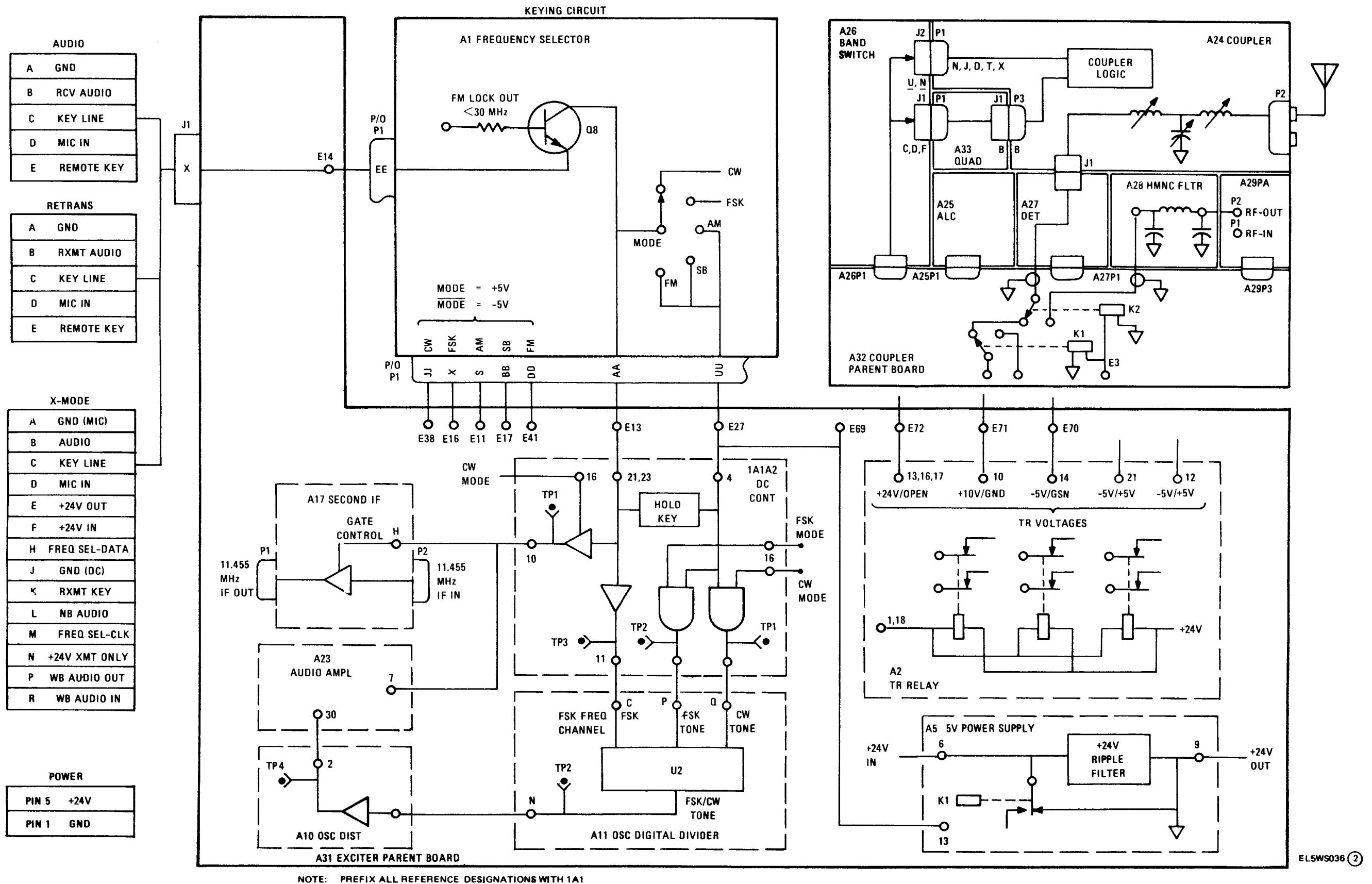

Figure FO-9. Voltage distribution detailed block diagram (sheet 2 of 2).

AUDIO

A	GND
B	RCV AUDIO
C	KEY LINE
D	MIC IN
E	REMOTE KEY

RETRANS

A	GND
B	RXMT AUDIO
C	KEY LINE
D	MIC IN
E	REMOTE KEY

X-MODE

A	GND (MIC)
B	AUDIO
C	KEY LINE
D	MIC IN
E	+24V OUT
F	+24V IN
H	FREQ SEL-DATA
J	GND (DC)
K	RXMT KEY
L	NB AUDIO
M	FREQ SEL-CLK
N	+24V XMT ONLY
P	WB AUDIO OUT
R	WB AUDIO IN

POWER

PIN 5	+24V
PIN 1	GND

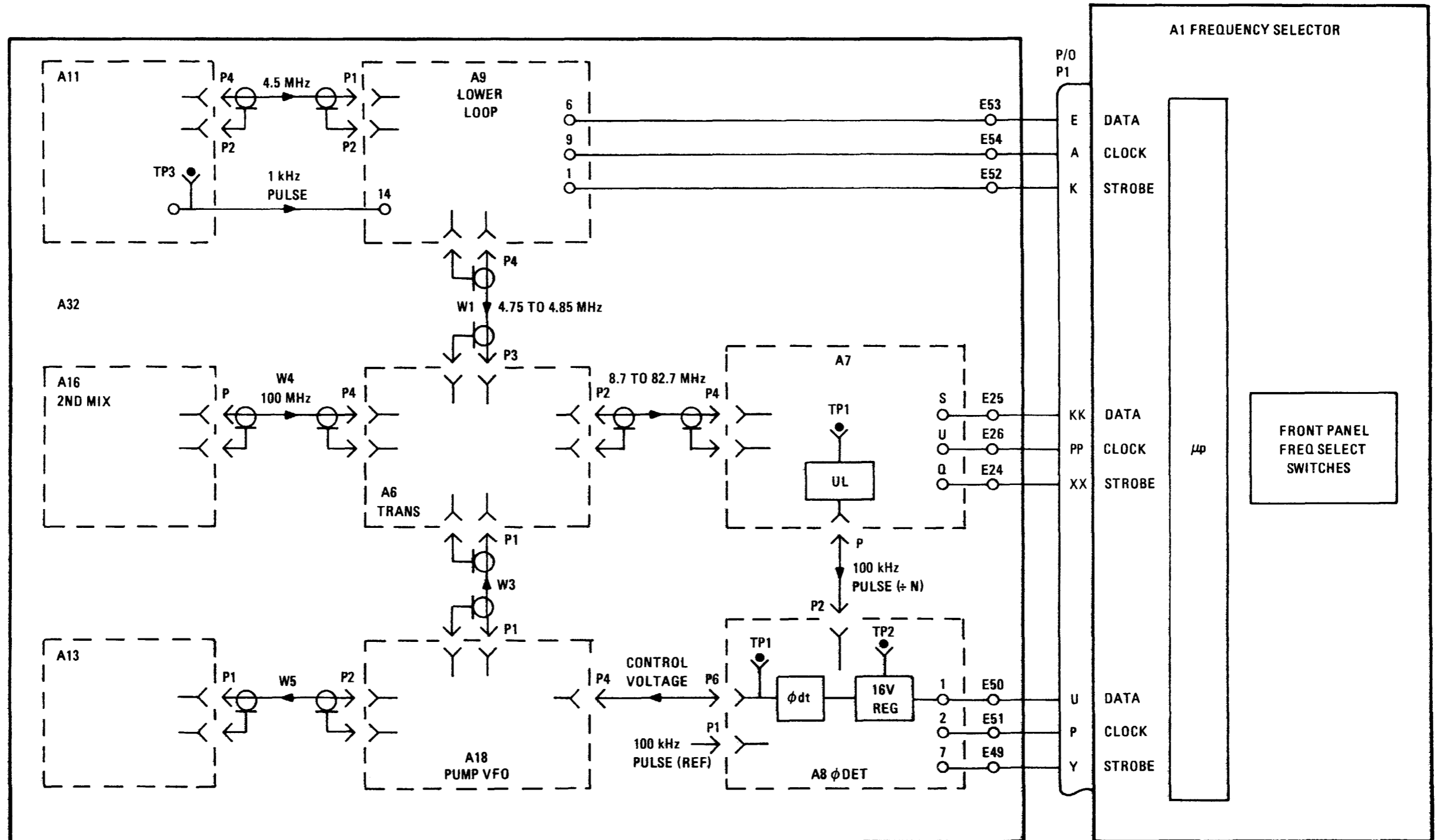

Figure FO-10. Synthesizer detailed block diagram.

Figure FO-17

EL5WS037

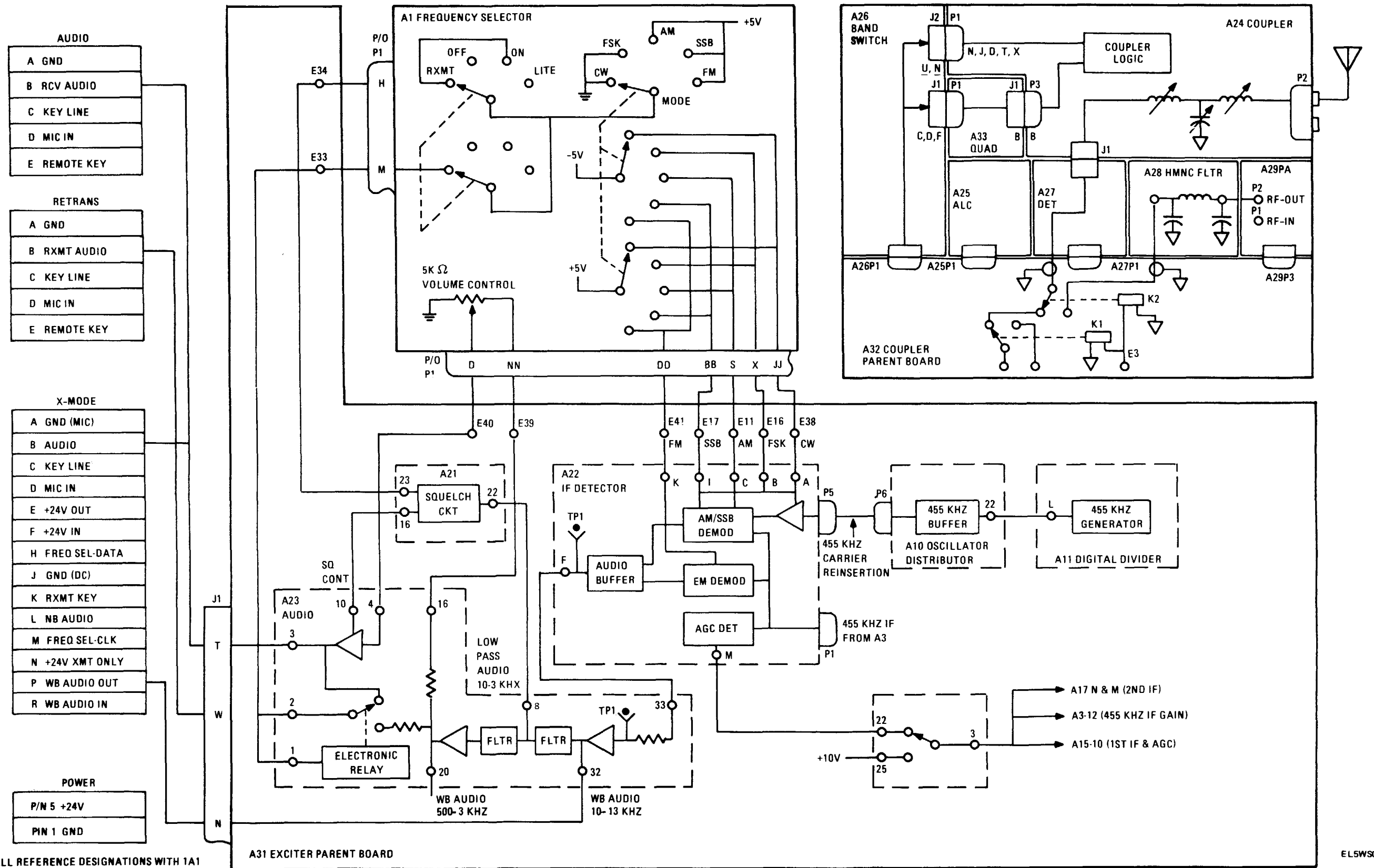
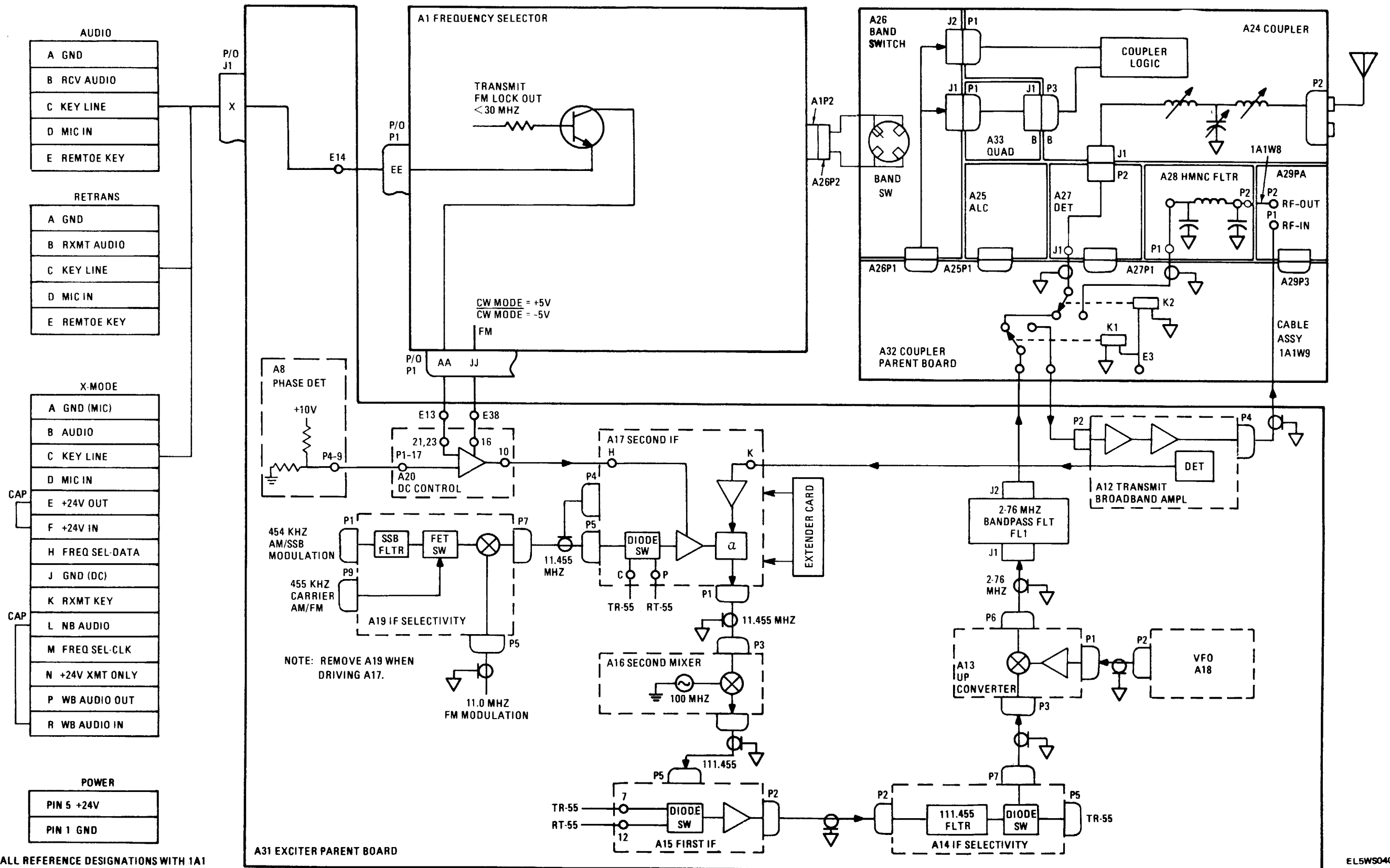

Figure FO-12. Audio (RCU) detailed block diagram.

EL5WS039



NOTE: PREFIX ALL REFERENCE DESIGNATIONS WITH 1A1

EL5WS040

Figure FO-13. Transmit RF/IF detailed block diagram.

AUDIO

A	GND
B	RCV AUDIO
C	KEY LINE
D	MIC IN
E	REMOTE KEY

RETRANS

A	GND
B	RXMT AUDIO
C	KEY LINE
D	MIC IN
E	REMOTE KEY

X-MODE

A	GND (MIC)
B	AUDIO
C	KEY LINE
D	MIC IN
E	+24V OUT
F	+24V IN
H	FREQ SEL-DATA
J	GND (DC)
K	RXMT KEY
L	NB AUDIO
M	FREQ SEL-CLK
N	+24V XMT ONLY
P	WB AUDIO OUT
R	WB AUDIO IN

POWER

PIN 5	+24V
PIN 1	GND

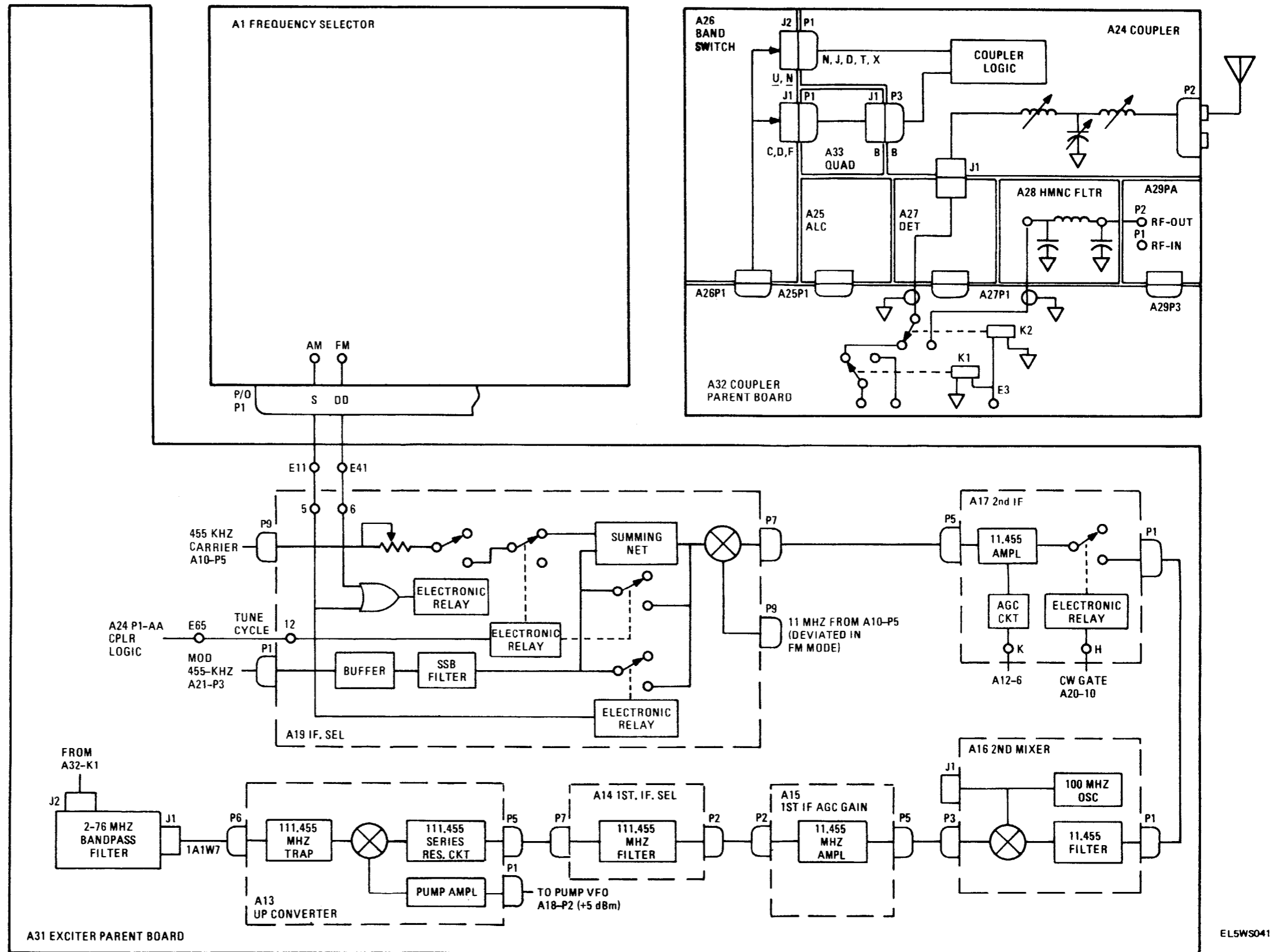

NOTE: PREFIX ALL REFERENCE DESIGNATIONS WITH 1A1

Figure FO-14. Transmit IF detailed block diagram.

EL5WS041

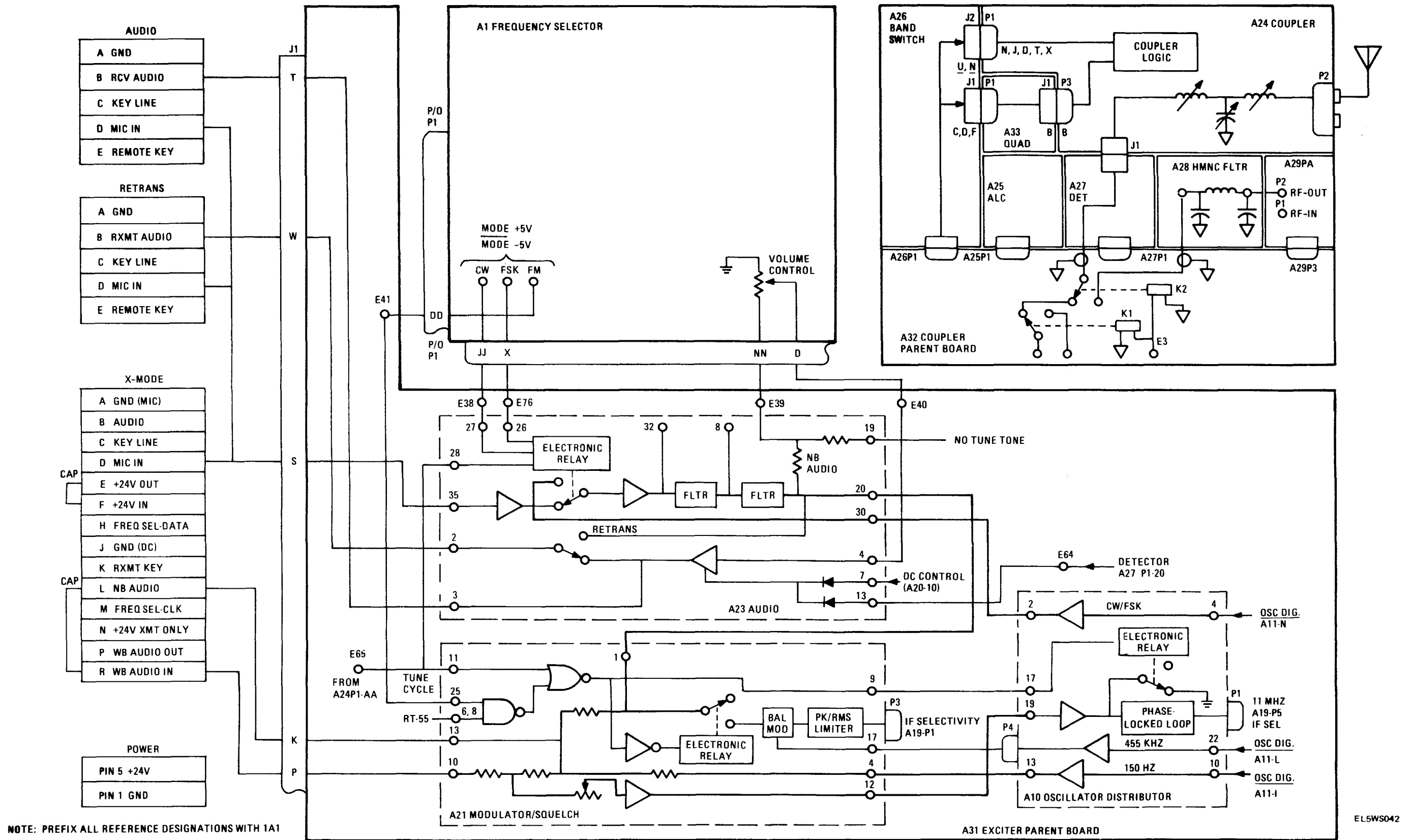

Figure FO-15. Transmit audio detailed block diagram.

DEPARTMENT OF THE ARMY
 US ARMY PUBLICATIONS CENTER
 1655 WOODSON ROAD
 ST. LOUIS, MISSOURI 63114-6181

OFFICIAL BUSINESS
 PENALTY FOR PRIVATE USE, \$300

COMMANDER MC499
 USAMC MAT RECS SFT ACTV
 ATTN AMXND-FC(LIEFAPY)
 LEXINGTON KY 40511-5101

DA PUBLICATION/FORM NUMBER				CHG OR DATE	
TM 11-5820-553-23					
LOCATION	QUANTITY	UNIT OF ISSUE	ACTION	FROM DATE	
K5354	1	EA		E12E	
PKG SIZE	ITEM NO.	BULK/RCPY DATE	SLAGPC CONTROL NO.		
	368119	BLK8127	E13C 1C17C		

APC FORM 4-26S (10 Sep 86) ZONE 4
 PREVIOUS EDITION MAY BE USED TILL EXHAUSTED

