

*HANDBOOK OF INSTRUCTIONS*

•

**RADIO RECEIVERS**  
**BC-224-B • BC-348-B**  
**RCA MFG. CO.**

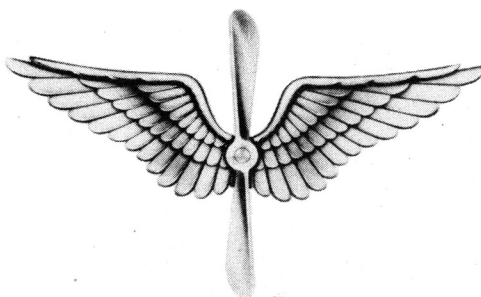

*NOTE: This Technical Order replaces identifying T. O. No. 08-10-25 dated June 20, 1940, and the Instruction Book identified thereby.*

*NOTICE: This document contains information affecting the National Defense of the United States within the meaning of the Espionage Act, 50 U. S. C., and 32, as amended. Its transmission or the revelation of its contents in any manner to an unauthorized person is prohibited by law.*

**PUBLISHED BY AUTHORITY OF THE COMMANDING GENERAL,  
ARMY AIR FORCES BY THE HEADQUARTERS, AIR SERVICE  
COMMAND, PATTERSON FIELD, FAIRFIELD, OHIO**

RESTRICTED

T. O. No. 08-10-25

RADIO RECEIVERS BC-224-B and BC-348-B

Manufactured by

RCA MANUFACTURING COMPANY, INC.

CAMDEN, N. J.

Paragraph 5d of Army Regulation 380-5 relative to the handling of printed matter which has been classified as "Restricted" is quoted for the information of all concerned:

"d. Dissemination of restricted matter. -- The information contained in restricted documents and the essential characteristics of restricted material may be given to any person known to be in the service of the United States and to persons of undoubted loyalty and discretion who are cooperating in Government work, but will not be communicated to the public or to the press except by authorized military public relations agencies".

# TABLE OF CONTENTS

	Page
Section I General Description of Complete Equipment .....	1
1 General .....	1
2 Component Units .....	1
3 Cabinet .....	5
4 Chassis .....	5
5 Panel .....	5
6 Dial and Mask Assembly .....	5
7 R-F and Oscillator Units .....	5
8 I-F Transformers, Beat Frequency Oscillator and Crystal Filter .....	5
9 Mounting FT-154-B .....	5
10 Plug PL-P103 and Plug PL-Q103 .....	5
11 Illumination .....	5
Section II Employment .....	8
12 Installation .....	8
a Mounting .....	8
b Power Connections .....	8
c Transmitter Connections .....	8
d Output Connections .....	8
e Bonding and Shielding .....	9
f Mounting of Receiver .....	9
g Safety Wire .....	9
h Ground .....	9
i Antenna .....	9
13 Preparation for Use .....	9
14 Operation .....	9
a Power Switch .....	9
b Operating Test .....	9
c Operating Routine .....	10
Section III Detailed Functioning of Parts .....	12
15 Circuits .....	12
16 Frequency Range and Frequency Bands .....	12
17 Input Coupling .....	12
18 Input Protection .....	12
19 Radio Frequency Amplifier .....	12
20 First Detector .....	12

## TABLE OF CONTENTS—Continued

	Page
21 Heterodyne Oscillator .....	12
22 Intermediate-Frequency Amplifier .....	12
23 C-W Oscillator .....	13
24 Crystal Band-Pass Filter .....	14
25 Second Detector .....	14
26 Output .....	14
a Description .....	14
b Constant Internal Receiver Noise .....	14
27 Dynamotors DM-24-B and DM-28-B .....	15
28 Characteristics of Tubes, Lamps, Voltage Regulator and Fuse .....	15
Section IV Maintenance .....	16
29 Inspection .....	16
30 Care and Servicing Dynamotors DM-24-B and DM-28-B .....	16
31 Removal of Front Panel .....	18
32 Dial and Mask Assembly .....	19
33 Removal and Replacement of Dial Mechanism .....	21
34 Removal of Antenna, R-F, Detector and Oscillator Units .....	21
35 Trouble Location and Remedy .....	22
a General .....	22
b Equipment Required .....	23
c Weak or No Signals on All Bands, Modulated Reception .....	23
d Weak or No Signals on Any One Band, Modulated Reception .....	29
e Weak or No Signals on All Bands, C-W Reception (Modulated Reception Normal) .....	29
f Measurements with Test Set I-56-A .....	29
g Failure of Dial Lights .....	35
Section V Supplementary Data and List of Replaceable Parts .....	36

## LIST OF ILLUSTRATIONS

Figure		Page
1	Radio Receiver BC-224-B .....	viii
"	2 Radio Receiver BC-348-B .....	viii
"	3 Bottom and Back View of Cabinet .....	2
"	4 Mounting FT-154-B with Plug PL-Q103 Attached .....	2
"	5 Radio Receiver BC-224-B: Front View of Chassis with Tube Shelf Cover Removed .....	3
"	6 Radio Receiver BC-348-B: Front View of Chassis with Tube Shelf Cover Removed .....	3
"	7 Radio Receiver BC-224-B: Top View of Chassis .....	4
"	8 Radio Receiver BC-348-B: Top View of Chassis .....	4
"	9 Radio Receiver BC-224-B: Bottom View of Chassis .....	6
"	10 Radio Receiver BC-348-B: Bottom View of Chassis .....	6
"	11 Radio Receiver BC-224-B: Rear View of Chassis .....	7
"	12 Radio Receiver BC-348-B: Rear View of Chassis .....	7
"	13 Plug Connections .....	8
"	14 Mounting FT-154-B and Plugs PL-P103 and PL-Q103 .....	11
"	15 C-W Oscillator Switching .....	13
"	16 Details of Crystal Filter Circuit .....	14
"	17 Load Compensator and Bleeder Circuit Details .....	15
"	18 Dynamotor DM-24-B and View Showing Filter Open .....	17
"	19 Dynamotor DM-28-B .....	18
"	20 Dynamotor DM-24-B, Disassembled .....	19
"	21 Dynamotor DM-28-B, Disassembled .....	20
"	22 Trouble Location and Correction Chart .....	22
"	23 Radio Receiver BC-224-B: Dynamotor and Tube Socket Voltages .....	23
"	24 Radio Receiver BC-348-B: Dynamotor and Tube Socket Voltages .....	24
"	25 I-F Transformers, C-W Oscillator and Crystal Filter Assemblies .....	25
"	26 Antenna Unit .....	26
"	27 R-F Unit .....	27
"	28 Detector Unit .....	28
"	29 Oscillator Unit .....	30
"	30 Radio Receiver BC-224-B: Resistor Boards, View A .....	32
"	31 Radio Receiver BC-224-B: Resistor Boards, View B .....	32
"	32 Radio Receiver BC-348-B: Resistor Boards, View A .....	33
"	33 Radio Receiver BC-348-B: Resistor Boards, View B .....	33
"	34 Radio Receiver BC-224-B: Schematic Circuit Diagram .....	59
"	35 Radio Receiver BC-348-B: Schematic Circuit Diagram .....	61
"	36A Radio Receiver BC-224-B: Wiring Diagram .....	63
"	36B Radio Receiver BC-348-B: Wiring Diagram .....	65
"	36C Radio Receiver BC-224-B: Wiring Diagram, Tube Shelf .....	67
"	36D Radio Receiver BC-348-B: Wiring Diagram, Tube Shelf .....	69

LIST OF ILLUSTRATIONS—Continued

		Page
Figure	36E Wiring Diagram, Antenna Unit .....	71
"	36F Wiring Diagram, R-F Unit .....	73
"	36G Wiring Diagram, Detector Unit .....	75
"	36H Wiring Diagram, Oscillator Unit .....	77
"	36I Wiring Diagram, I-F Transformers .....	79
"	36J Wiring Diagram, Crystal Filter .....	81
"	36K Wiring Diagram, Beat Frequency Oscillator .....	83
"	36L Radio Receiver BC-224-B Resistor Board Wiring Diagram .....	85
"	36M Radio Receiver BC-348-B Resistor Board Wiring Diagram .....	87
"	36N Wiring Diagram, Dynamotor Filter .....	89
"	37 Dial and Mask Assembly .....	91
"	38 General Views of Radio Receivers BC-224-B and BC-348-B.....	93
"	39 Outline Dimensional Drawing .....	95
"	40 Drilling Plan .....	97



FIGURE 1—RADIO RECEIVER BC-224-B



FIGURE 2—RADIO RECEIVER BC-348-B

SECTION I

GENERAL DESCRIPTION OF COMPLETE EQUIPMENT

1 GENERAL

Radio Receivers BC-224-B and BC-348-B are locally controlled, 8-tube, 6-band super-heterodyne receivers for use in U. S. Army aircraft and cover the frequency range 1.5 to 18.0 megacycles. The receivers are not intended for remote control, and no features or units have been provided for remote operation. These receivers are capable of voice, tone and c-w reception with manual or automatic volume control. The receivers, when equipped with tubes, dial lights and fuses, and with the antenna, ground, and primary power source connections properly made, become complete and operative equipments by the addition of headsets, as all coils and the high voltage power supply units are built into the receivers. The total power consumed by each receiver is 56 watts. Radio Receivers BC-224-B and BC-348-B are essentially alike. Electrically the filament circuit and high voltage supply units differ to permit the BC-224-B to operate from a 14-volt and the BC-348-B from a 28-volt power source. A dowel pin fastened to the chassis of the BC-348-B prevents accidental installation of Dynamotor DM-24-B in the receiver. There are minor mechanical differences incidental to supporting electrical parts not common to the two receivers. These parts in the BC-348-B which are not identical to those in the BC-224-B are:

- Part 500, Dial Rheostat which replaces part 60.
- Part 501, Resistor which replaces parts 54 and 55.
- Part 502, Fuse FU-35, which replaces part 118 Fuse FU-23.
- Part 503, Resistor, added part in series with the dial lamps of BC-348-B.
- Part 504, Fuse Clip Assembly which replaces part 216.
- Part 510, Dynamotor DM-28-B\* which replaces part 300, Dynamotor DM-24-B.\*

2 COMPONENT UNITS

The following is a list of the component units of Radio Receiver BC-224-B:

	Size in inches	Weight in pounds
1 Radio Receiver BC-224-B (Includes Dynamotor DM-24-B* and Mounting FT-154-B.	18 x 10 1/2 x 9 1/2	35.2

	Size in inches	Weight in pounds
1 Mounting FT-154-B (Does not include Plug PL-P103 or PL-Q103.	18 x 8 1/2 x 1 3/8	3.81
1 { Plug PL-P103... 2 1 5/8 x 2-5/32 x 1 9/16 or Plug PL-Q103... 3 x 2-5/32 x 2 1/16		0.34 0.41
1 Tube VT-48 ... 41	4 3/16 x 1 9/16 dia.	0.08
1 Tube VT-65 ... 6C5	2 5/8 x 1 5/16 dia.	0.08
1 Tube VT-70 ... 6F7	4 1/2 x 1 9/16 dia.	0.09
3 Tubes VT-86 @. 6K7	3 1/8 x 1 5/16 dia.	0.08
1 Tube VT-91 ... 6J7	3 1/8 x 1 5/16 dia.	0.09
1 Tube VT-93 ... 6B8	3 1/8 x 1 5/16 dia.	0.09
2 Lamps LM-27 @	1 1/8 x 1/2 dia.	0.01
1 Voltage Regulator RCA-991 .....	1 1/2 x 1 1/8 dia.	0.02
1 Fuse FU-23 ....	1 1/4 x 1/4 dia.	0.01

The following is a list of the component units of Radio Receiver BC-348-B:

	Size in inches	Weight in pounds
1 Radio Receiver BC-348-B (Includes Dynamotor DM-28-B* and Mounting FT-154-B.	18 x 10 1/2 x 9 1/2	35.5
1 Mounting FT-154-B (Does not include Plug PL-P103 or PL-Q103.	18 x 8 1/2 x 1 3/8	3.81
1 { Plug PL-P103... 2 1 5/8 x 2-5/32 x 1 9/16 or Plug PL-Q103... 3 x 2-5/32 x 2 1/16		0.34 0.41
1 Tube VT-48 ...	4 3/16 x 1 9/16 dia.	0.08
1 Tube VT-65 ...	2 5/8 x 1 5/16 dia.	0.08
1 Tube VT-70 ...	4 1/2 x 1 9/16 dia.	0.09
3 Tubes VT-86 @.	3 1/8 x 1 5/16 dia.	0.08
1 Tube VT-91 ...	3 1/8 x 1 5/16 dia.	0.09
1 Tube VT-93 ...	3 1/8 x 1 5/16 dia.	0.09
2 Lamps LM-27 @	1 1/8 x 1/2 dia.	0.01
1 Voltage Regulator RCA-991 .....	1 1/2 x 1 1/8 dia.	0.02
1 Fuse FU-35 ....	1 1/4 x 1/4 dia.	0.01

\* The nameplates on some "Dynamotors DM-24-B" erroneously give the nomenclature as "Dynamotor Unit DM-24-B." The same error also occurs on some nameplates of "Dynamotor DM-28-B."



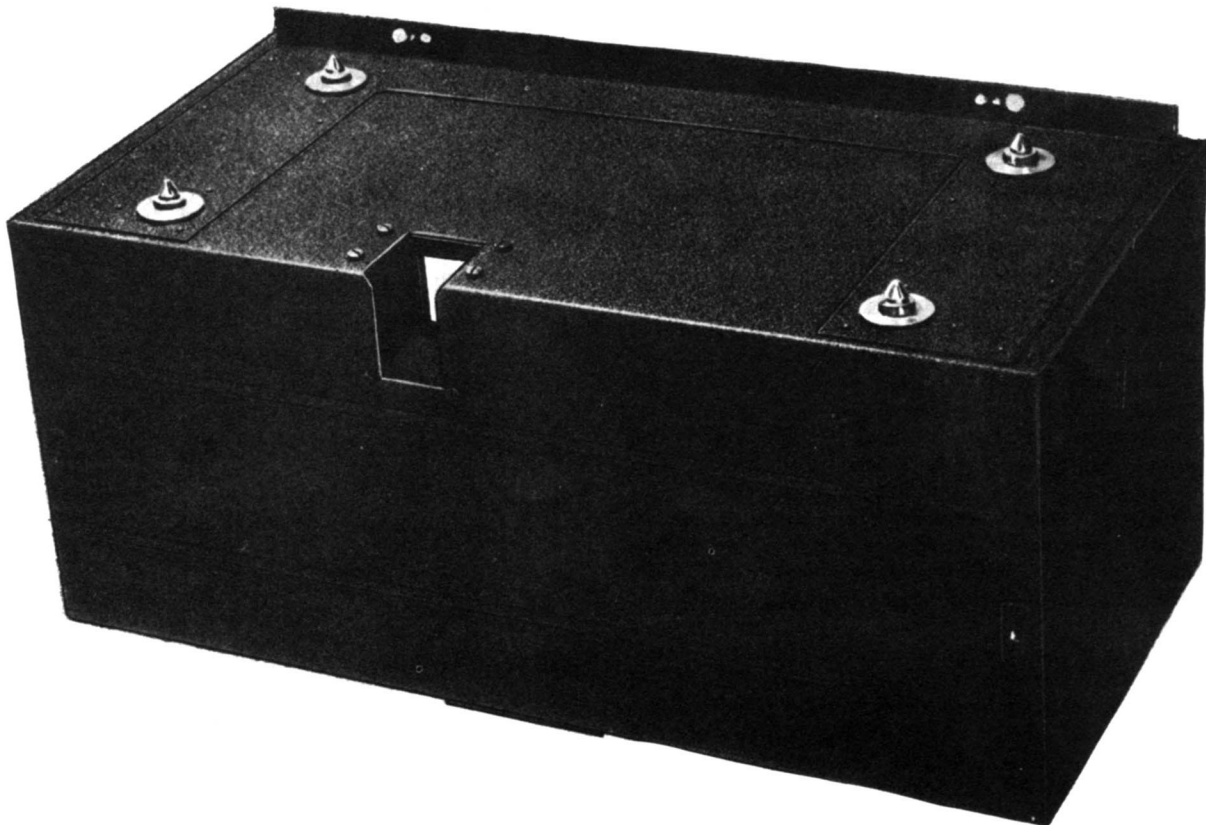

FIGURE 3—BOTTOM AND BACK VIEW OF CABINET

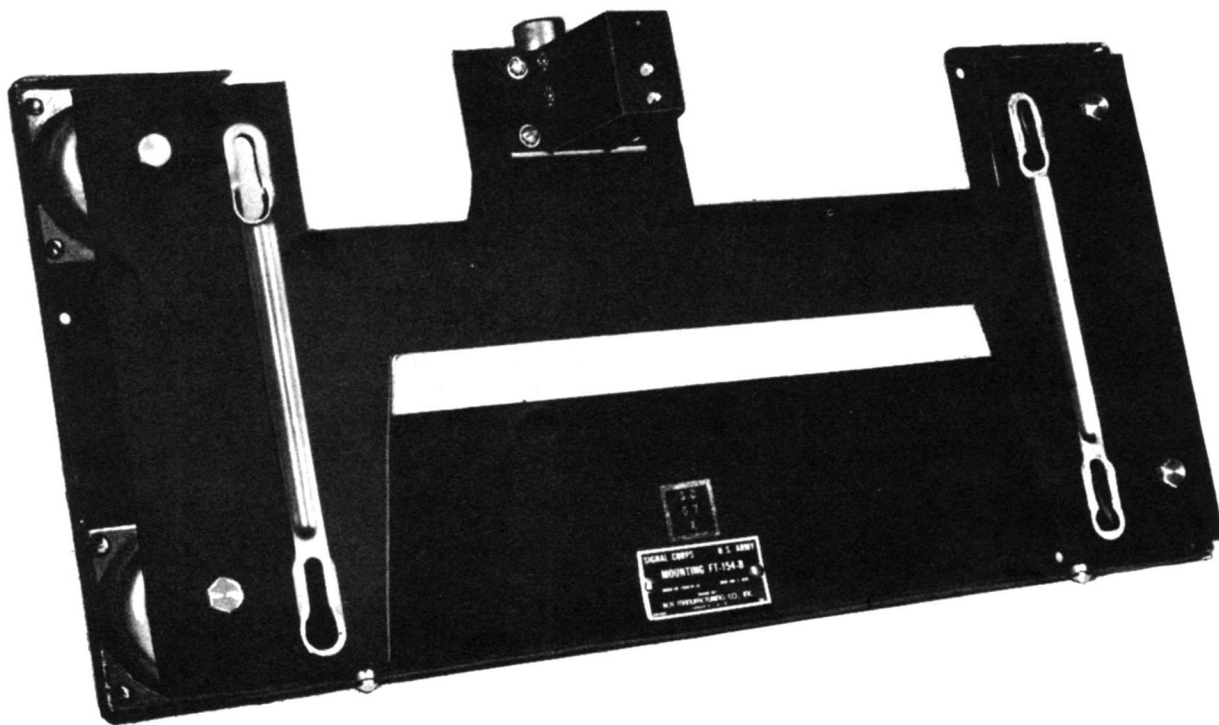

FIGURE 4—MOUNTING FT-154-B WITH PLUG PL-Q103 ATTACHED

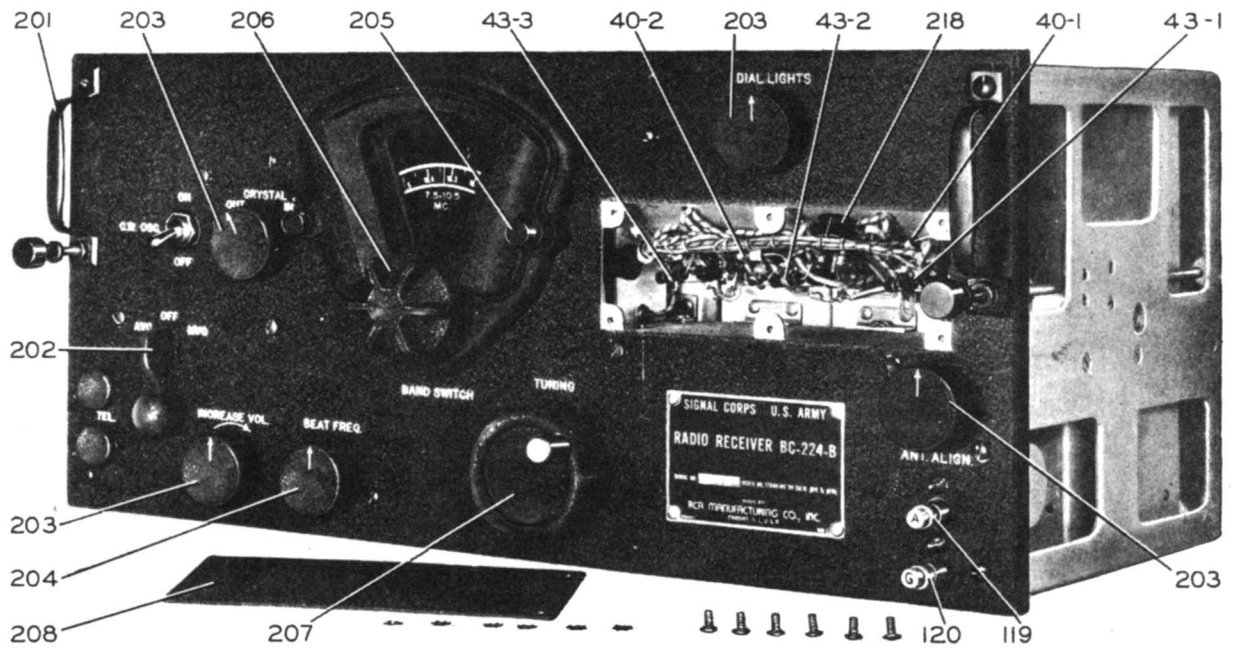

FIGURE 5—RADIO RECEIVER BC-224-B: FRONT VIEW OF CHASSIS WITH TUBE SHELF COVER REMOVED

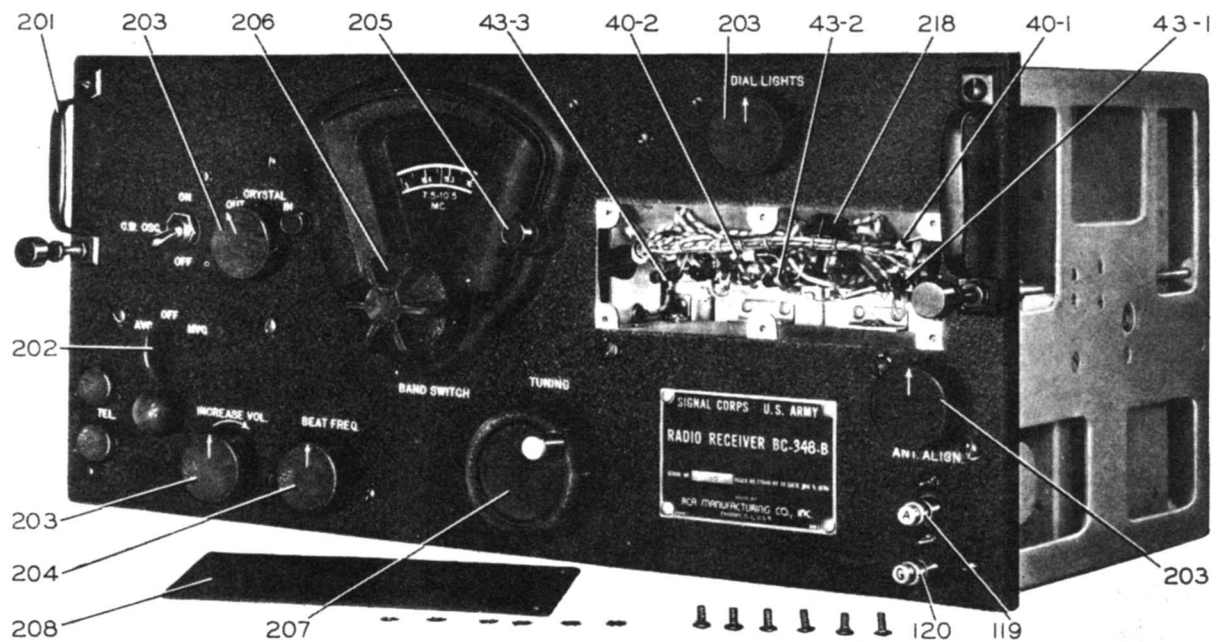

FIGURE 6—RADIO RECEIVER BC-348-B: FRONT VIEW OF CHASSIS WITH TUBE SHELF COVER REMOVED

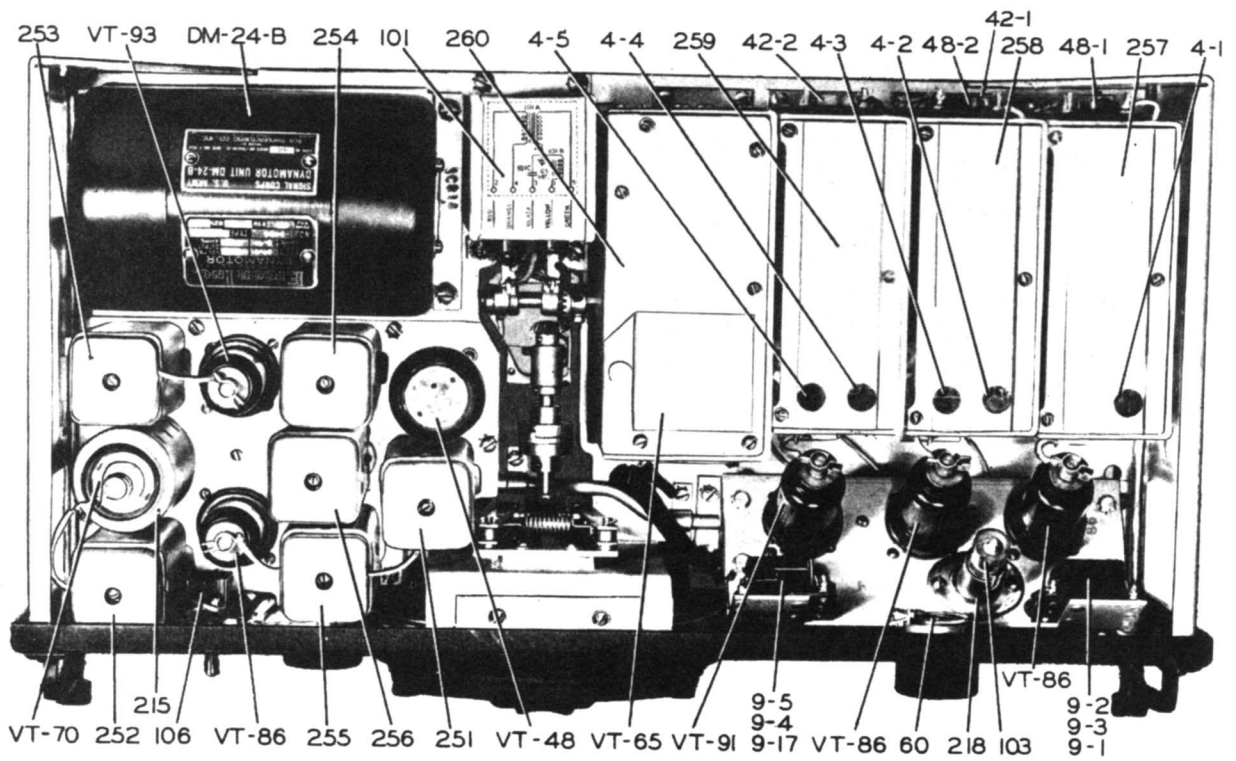

FIGURE 7—RADIO RECEIVER BC-224-B: TOP VIEW OF CHASSIS

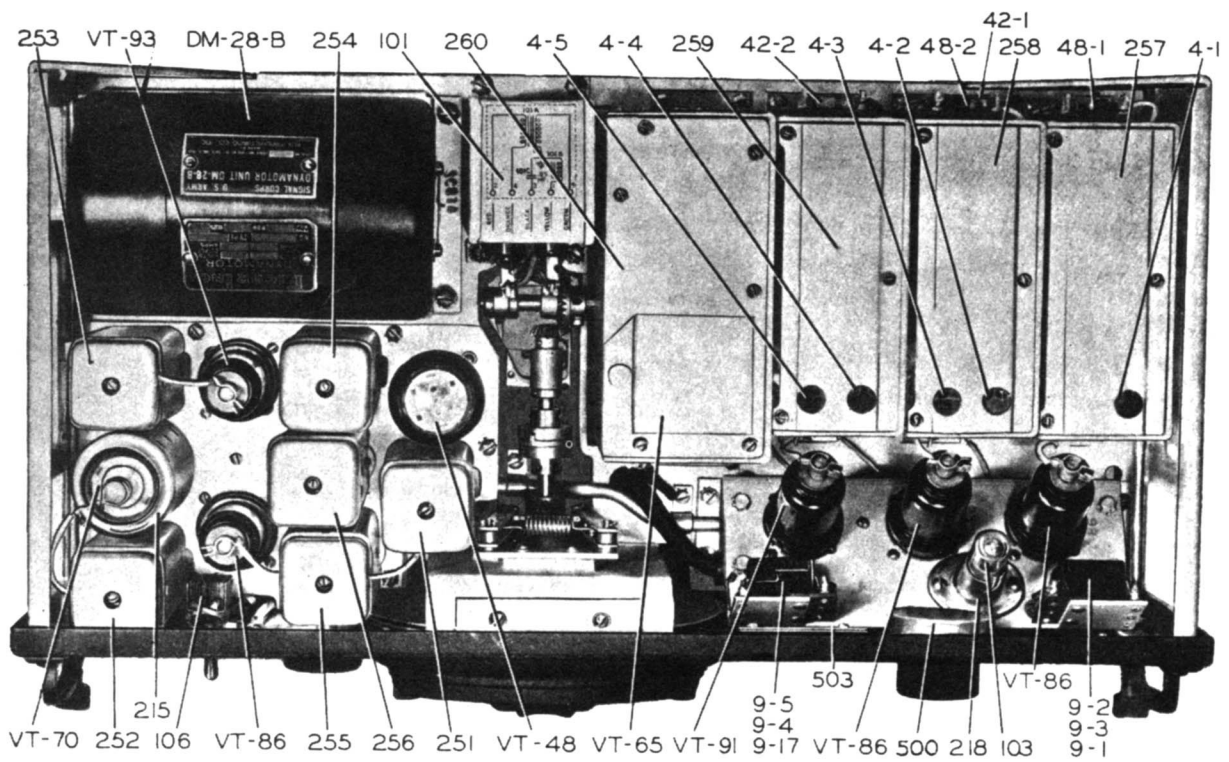

FIGURE 8—RADIO RECEIVER BC-348-B: TOP VIEW OF CHASSIS

### 3 CABINET

The receiver cabinet is of spot-welded aluminum construction with black wrinkle finish, and is embossed on the top and back to add rigidity and strength. The panel (front) end allows the removal of the receiver chassis which runs on the stainless steel strips mounted in the end corners of the cabinet. Two tapped inserts are placed in the rear to receive the thumb screw rods which secure the chassis in the cabinet. A cutout in the rear bottom permits the entrance of Plug PL-P103 or PL-Q103. An aluminum casting is mounted over this cutout and acts as a seal between the cabinet and the chassis. The bottom of the cabinet is reinforced by a stainless steel plate to which are attached the four mounting studs for securing the cabinet to Mounting FT-154-B. Two snap slides are mounted on the downward projection of the front of the stainless steel plate.

### 4 CHASSIS

The chassis consists of an aluminum casting mounted between two end plates of sheet aluminum which serve as runners and guides when placing the chassis in the cabinet. The end plates are provided with cutouts to facilitate servicing.

### 5 PANEL

The front panel is attached to the chassis and to the end plates by screws. Two handles are mounted on the panel and two thumb screw rods which secure the chassis in the cabinet pass through the lower part of these handles. A cutout covered by a plate is provided to give access to the wiring under the r-f tube shelf for servicing and maintenance. The following panel items are mounted on the front of the panel:

Antenna and ground binding posts; antenna alignment control; dial light rheostat control; tuning control; band switch control; dial window housing which covers the dial lights; beat frequency control; crystal filter control; volume control; "AVC-OFF-MVC" control; "C.W. OSC." control; and two telephone jacks.

### 6 DIAL AND MASK ASSEMBLY

The dial and mask assembly is mounted on an aluminum casting which carries the gearing of the tuning condenser drive and the detent. This unit is attached to the front panel and connects to the band switch drive shaft through a coupling of the Oldham type. The dial is divided into six frequency bands and the dial and tuning condenser are so geared to the tuning control shaft that the tuning condenser covers the frequency range indicated on the dial for each band in approximately 90 revolutions of the tuning knob. Split gearing is used throughout to

minimize backlash. A positive stop is provided to prevent undue pressure on the gears and to limit the travel of the dial and the tuning condenser.

A mask, with suitably located and marked windows, is mounted before the dial. The mask is controlled by the band change switch and is positioned by the detent.

### 7 R-F AND OSCILLATOR UNITS

The antenna, r-f, 1st detector and oscillator sub-assemblies are mounted on the right rear portion of the chassis. Each sub-assembly consists of the r-f coils, trimmers and band switch wafers with the necessary fixed capacitors and resistors. Passing through all of these sub-assemblies is the band switch drive shaft which is pulled out from the right end of the receiver chassis before a sub-assembly is removed.

### 8 I-F TRANSFORMERS, BEAT FREQUENCY OSCILLATOR AND CRYSTAL FILTER

These units are mounted on the left front portion of the chassis. The variable capacitor of the Beat Frequency Oscillator is controlled through a flexible shaft from the front panel.

### 9 MOUNTING FT-154-B

The mounting is constructed of stainless steel except for the aluminum base which carries the mounting holes and to which are attached the bases of 4 shock absorbers. To the top of the shock absorbers is fastened the stainless steel support, which provides for the attachment of the receiver cabinet by means of studs and snapslides. Grooves are provided in the stainless steel support to facilitate the engagement of the studs of the cabinet with the mounting.

### 10 PLUG PL-P103 AND PLUG PL-Q103

The plug, attached to the mounting by screws, is provided with eight terminals which are accessible upon removal of the rear cover of the plug housing. The plug, when provided with a straight outlet becomes Plug PL-P103. A right angle outlet which may be mounted in any of three positions, right, left or back may be used with the plug, making it Plug PL-Q103. The positions and uses of these outlets with the plug are clearly shown on the outline dimensional drawing in Section V (Fig. 39).

### 11 ILLUMINATION

The receiver tuning dial is illuminated by means of two dial lights (Lamps LM-27) controlled by the "DIAL LIGHTS" rheostat. This rheostat has an off position when the illumination is not desired. The dial lights are located beneath a readily removable housing which permits the easy replacement of a dial lamp during flight.

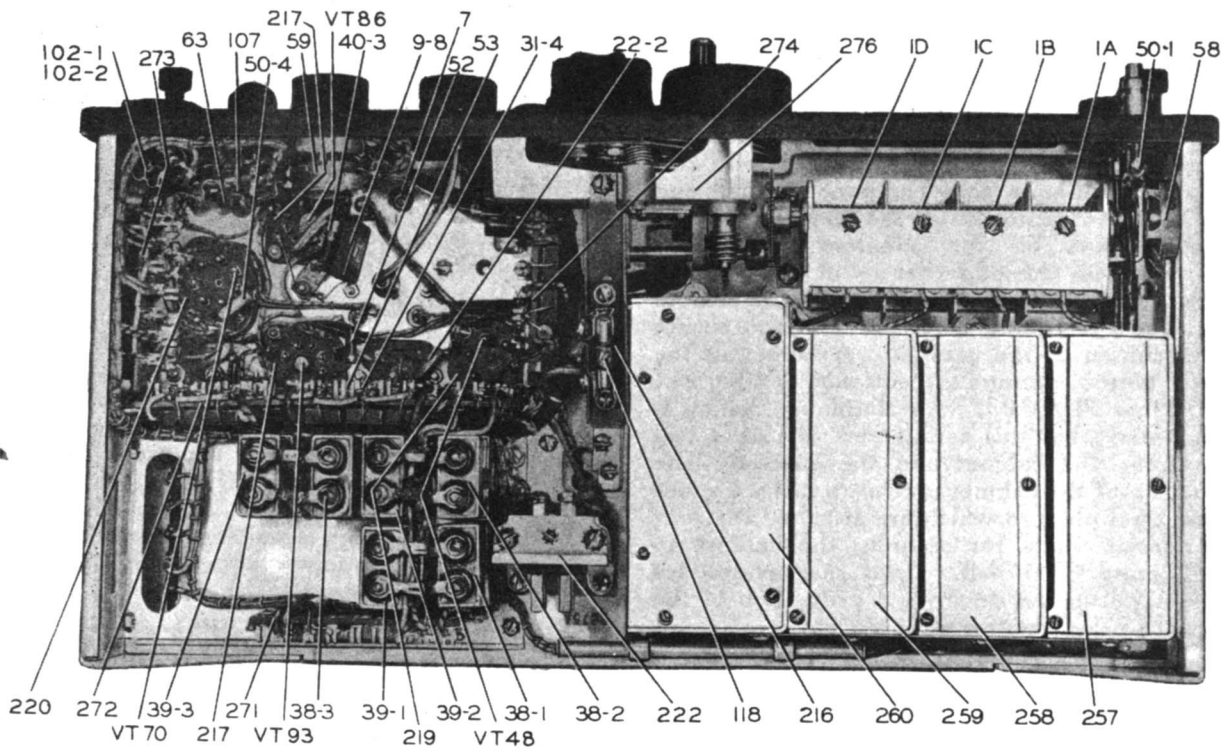

FIGURE 9—RADIO RECEIVER BC-224-B: BOTTOM VIEW OF CHASSIS

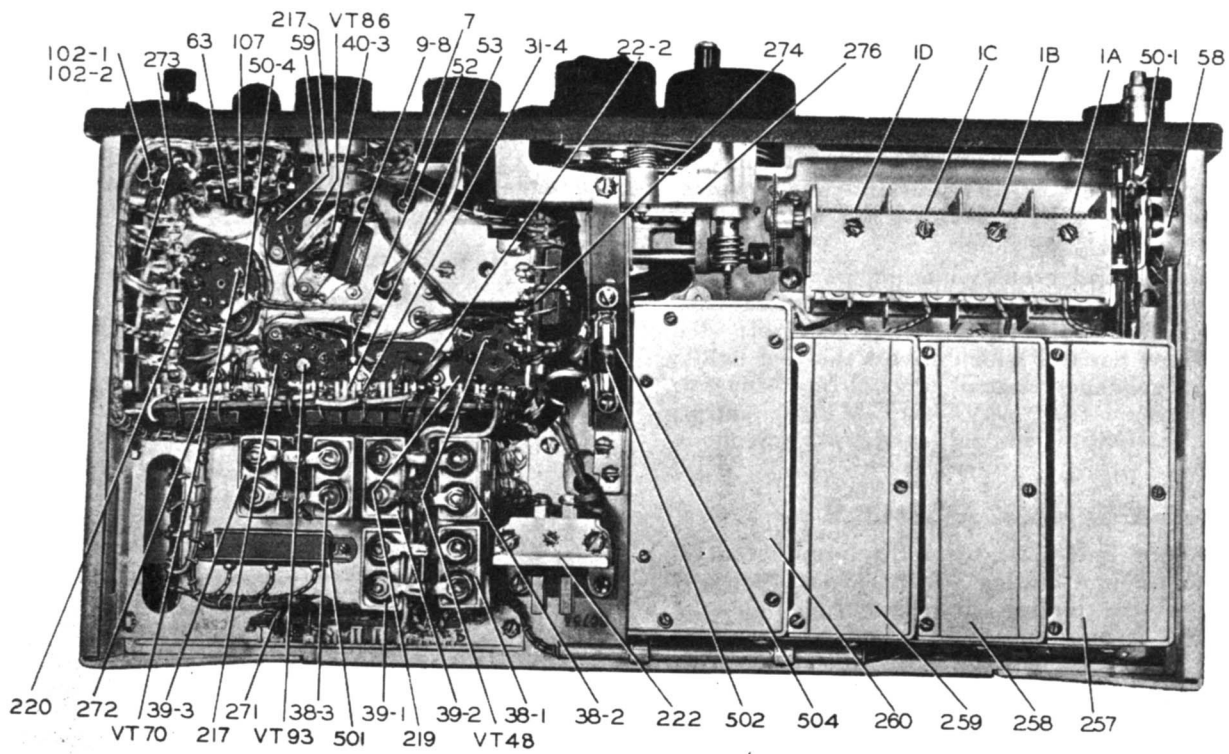

FIGURE 10—RADIO RECEIVER BC-348-B: BOTTOM VIEW OF CHASSIS

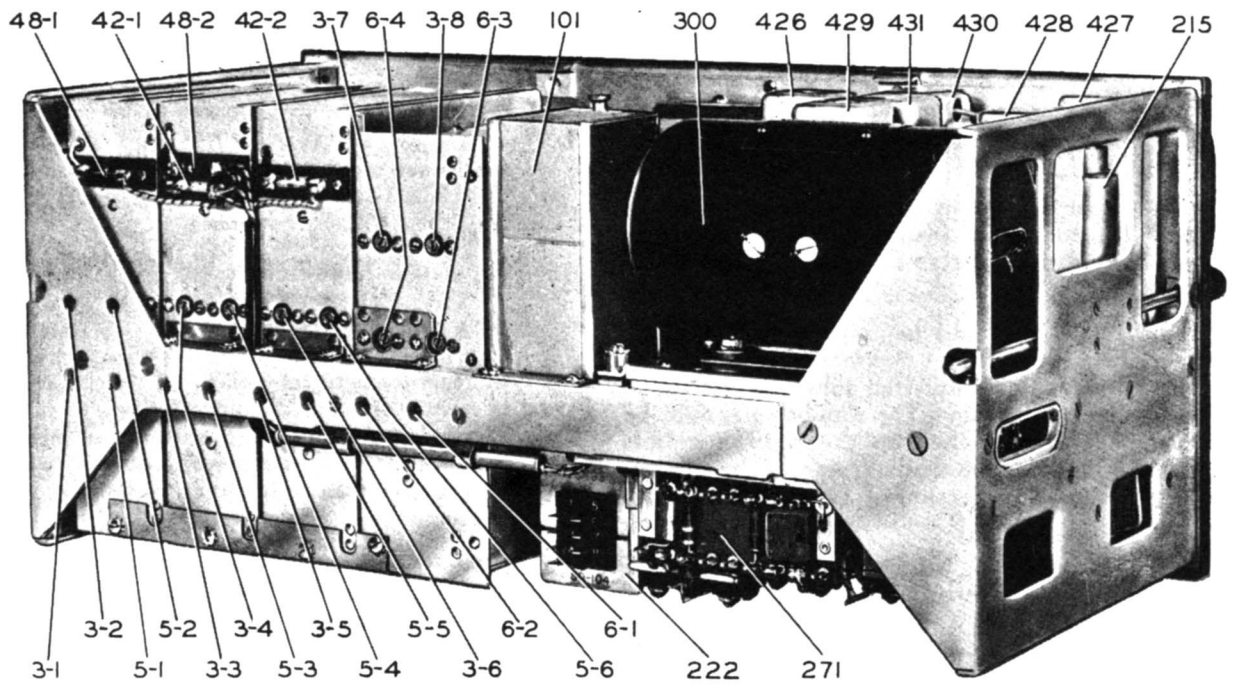

FIGURE 11—RADIO RECEIVER BC-224-B: REAR VIEW OF CHASSIS

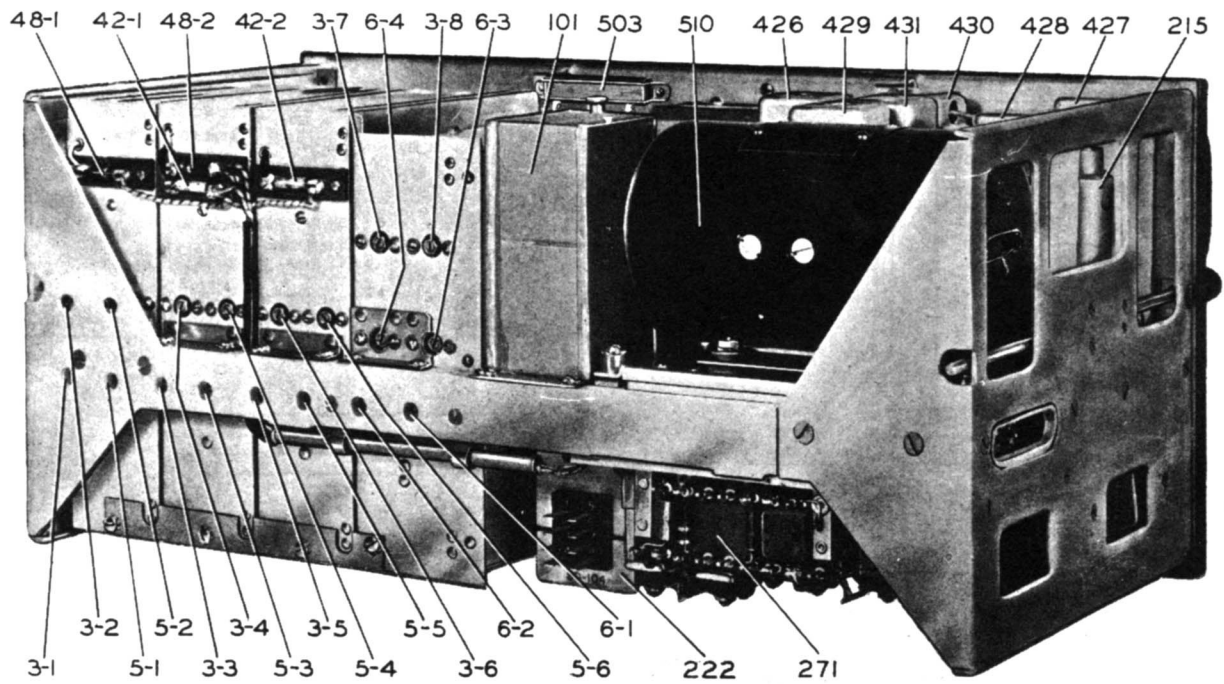

FIGURE 12—RADIO RECEIVER BC-348-B: REAR VIEW OF CHASSIS

## SECTION II EMPLOYMENT

### 12 INSTALLATION

The most important considerations necessary for the successful installation and operation of this receiver are as follows:

*a Mounting*

The receiver should be mounted on a plane surface with sufficient clearance being allowed on all sides to permit free action of the shock absorber mounting. The mounting should be permanently attached to the rigid members of the plane. The drilling plan of the mounting is shown in Section V (Fig. 40).

*b Power Connections*

The leads to the primary power source are connected as shown in Fig. 13. The parallel connected leads from plug terminals 3 and 4 may be replaced by a single conductor of cross section equivalent to the two separate leads. Similarly, the parallel connected leads from plug terminals 7 and 8 may be replaced by a single conductor of equivalent cross sectional area. The power source to which these

leads are connected should be 14 volts for the BC-224-B and 28 volts for the BC-348-B.

*c Transmitter Connections*

Provisions have been made for the protection of this receiver when the associated transmitter is being used. Leads from plug terminals 2 and 6 should be wired to contacts on the transmitter relay. If the transmitter is removed from the installation, or if the receiver is being installed without an associated transmitter, the wires from plug terminals 2 and 6 must be connected together to have the receiver operate.

*d Output Connections*

The output of this receiver has been brought to plug terminals 1 and 5 and to the two front-panel jacks. Leads from these terminals should be wired to the Interphone System or as otherwise desired. If the output is desired only at the receiver, it should be taken directly from the phone jacks and no connections made to plug terminals 1 and 5.

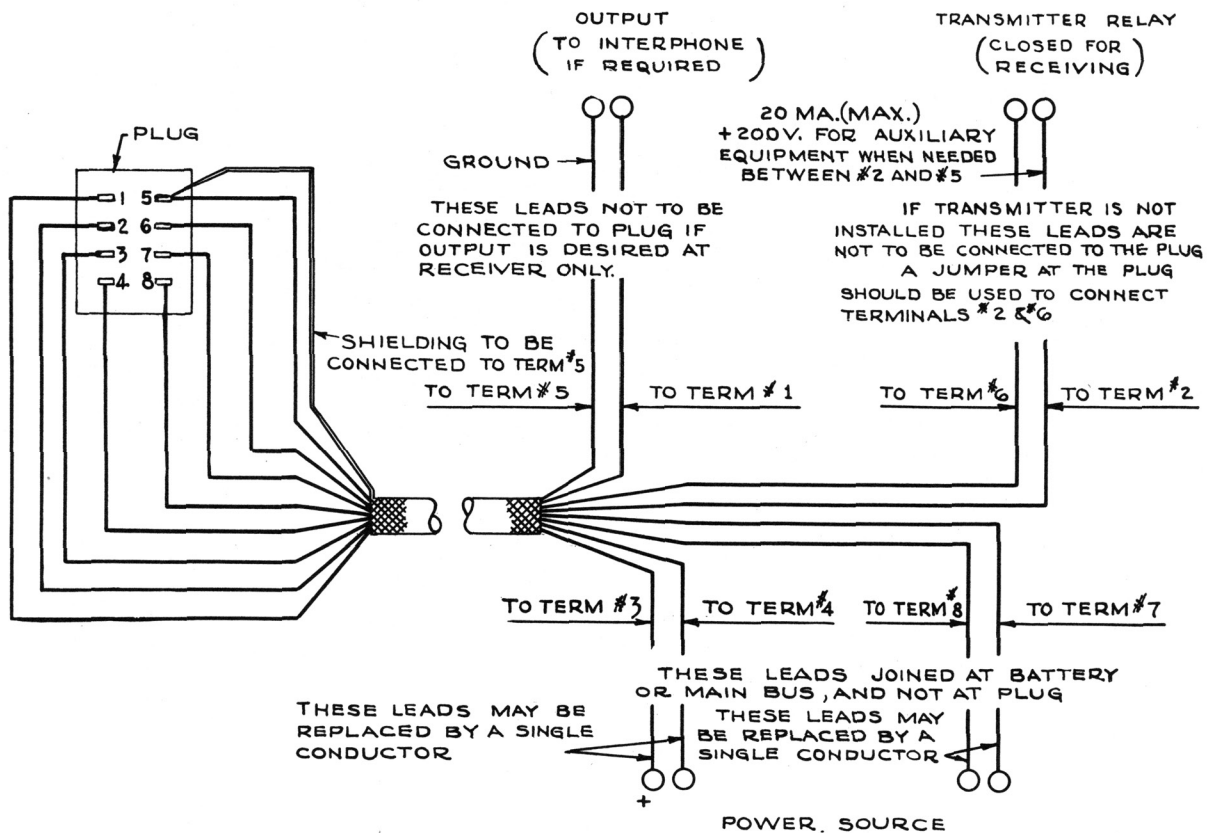

FIGURE 13—PLUG CONNECTIONS

*e Bonding and Shielding*

At the time of installation of this equipment, care should be taken to insure that the engine ignition system, generator, and other possible causes of disturbance are properly shielded and that bonding of metal parts is or has been carefully carried out.

*f Mounting of Receiver*

When proper wiring connections have been made, place the receiver on its mounting with the studs on the bottom of the cabinet entering the slots of the mounting. See that the cabinet is well down on the mounting and that all four studs are fully seated, then push the cabinet towards the rear and secure in place by the snapsides on the lower front corners of the cabinet.

*g Safety Wire*

Safety wire should be passed through the holes of the snapslide assemblies, care being taken that the wires are not twisted too tightly.

*h Ground*

The ground binding post "G" should be connected by a short, direct, low resistance lead to some grounded metal portion of the plane and soldered at that point, if practicable. The lead should have enough slack to prevent vibration being transmitted to the receiver.

*i Antenna*

The antenna circuit aligning capacitor is such that the antenna circuit can be properly aligned when using antennas that range in effective capacitance from 50 to 200 micro-microfarads. However, satisfactory performance will be obtained on practically any type of mast, fixed, or trailing wire antenna, although in extreme cases, i. e., very short mast or very long trailing wire, optimum setting of the antenna alignment control may not be obtained. In general, the most effective antenna is one whose length away from the grounded metal fuselage is the greatest. The receiver should be located as near as possible to the lead-in insulator and connected from the insulator to the antenna binding post "A" by a copper wire. The lead should have enough slack to prevent vibration being transmitted to the receiver.

**13 PREPARATION FOR USE**

This receiver is a self-contained unit, having its high voltage power supply and all coil sets built in. **BEFORE INSTALLING THE TUBES, THEY SHOULD BE CHECKED WITH THE REQUIRED TUBE CHECKER. BE SURE THAT THE PROPER TUBES, WELL PUSHED DOWN AND FIRMLY SEATED IN THEIR SOCKETS, ARE INSTALLED, THAT THE TUBE SHIELD IS PROPERLY SEATED, AND THAT GRID CAPS FIT TIGHTLY ON THE TUBES.**

Check dial lights and fuse and see that they are properly and securely placed. Make sure that the leads to the dynamotor unit are properly connected at the dynamotor terminal strip and that the screws holding them in place are tight. With the receiver "AVC-OFF-MVC" switch, in the "MVC" position and the band switch on Band 1, by means of the tuning control, tune in a signal at approximately 2.9 megacycles, to maximum signal strength. Reduce volume by means of volume control knob until signal is just audible. Adjust the antenna alignment control to given maximum volume.

**14 OPERATION**

*a Power Switch*

Power to the receiver is controlled by the receiver "AVC-OFF-MVC" switch. With this switch in the "OFF" position, no power is supplied to the receiver. When switched to either the "MVC" or "AVC" position, power from the primary source is supplied to the tube heaters and dynamotor placing the equipment in operation. The screen grid voltage supply leads are carried out of the receiver through the power plug to the keying relay of the associated transmitter where the circuit is opened when actually transmitting (Refer to Par. 12c).

*b Operating Test*

When the receiver has been completely installed, an operating test should be made as follows:

- (1) Plug a headset into one of the jacks marked "TEL." Set receiver switch to "MVC". The dynamotor should start and after the tubes have warmed up (approximately 30 seconds), the volume control knob should be advanced until a slight background noise is heard. Set band switch to the frequency band in which test signals are available.
- (2) Using the tuning knob and with reference to the calibrated scale on the dial, tune in the desired signal. *Note: All tuning should be done on "MVC" with the volume control advanced only enough to give the desired signal strength. In the absence of a signal the setting of the volume control can be judged by the loudness of the background noise. On "MVC", with the volume control set at maximum, very strong carrier waves will block the receiver and intelligible signals cannot be received.*
- (3) Set the receiver switch to "AVC". The desired signal should still be heard.
- (4) With the beat frequency adjustment at zero beat position (arrow on knob pointing up), turn the c-w oscillator switch to the position "On". An audible



## Par. 14

beatnote should be heard which should vary in pitch when the beat frequency adjustment is changed.

- (5) With the c-w oscillator still "ON", throw the crystal filter switch to "IN". Noise should be greatly reduced and the signal can be tuned out by a much smaller movement of the tuning control knob than when the crystal filter switch is in the "OUT" position.
- (6) Turn the dial light rheostat and observe if control of illumination is secured with both dial lights functioning.
- (7) A check should be made before flight and with the airplane engine running. An increase of background noise when the engine starts, indicates imperfect shielding, bonding, faulty generator regulator, faulty generator, open filter capacitors, or a combination of these faults.
- (8) Always turn the receiver switch to the "OFF" position when the receiver is not to be used.

### c Operating Routine

#### (1) Controls

##### (a) Antenna and Ground Binding Posts

The antenna is connected to the binding post marked "A", and the ground lead to the binding post marked "G".

##### (b) Antenna Alignment Control

This control varies a capacitor for aligning the input circuit to a given antenna. This adjustment should be made with the receiver tuned to approximately 2.9 megacycles.

##### (c) Tuning Control

This control varies the setting of the 4-gang variable tuning capacitor.

##### (d) Band Switch Control

This control selects the desired frequency band as indicated on the dial mask.

##### (e) Dial Lights Control

This knob controls the intensity of dial illumination and is provided with an off position.

##### (f) C-W Oscillator Switch

This toggle switch controls the operation of the c-w oscillator as well as the a-v-c time constant for c-w reception.

##### (g) Crystal Filter Switch

This control permits the insertion of an i-f crystal filter when extreme selectivity is desired.

##### (h) Beat Frequency Control

This control permits vernier adjustment of the c-w oscillator frequency and in tuning it should be set near the zero beat position (arrow on knob pointing up).

##### (i) Volume Control

This control is for sensitivity adjustment on "MVC" operation and output level adjustment on "AVC" operation. When switching from "MVC" to "AVC" or vice versa, it will generally be necessary to readjust this control to maintain a given volume level as only under certain conditions of signal strength will the volume level remain unchanged.

##### (j) "AVC-OFF-MVC" Switch

This three-position switch in the "OFF" position removes all power from the receiver. In the "MVC" position the receiver is operative with manual volume control, while in the "AVC" position the automatic volume control is functioning.

##### (k) Telephone Jacks

These are open circuit jacks providing connections to the headset.

#### (2) Modulated Signal Reception

- (a) Throw the "AVC-OFF-MVC" switch to "MVC" and set other switches and controls as follows:

"C-W OSC" - "OFF".  
"CRYSTAL" - "OUT".

Antenna alignment set as in Par. 13.

- (b) Set the band switch to the desired frequency band and adjust the tuning control to the desired frequency. It is of great importance that this tuning be accomplished with the receiver switch in the "MVC" position.

**NOTE:** The "AVC" position should not be employed while tuning in a signal. Tuning should always be done in the "MVC" position and with the volume control advanced only as far as required for a comfortable output level.

- (c) Increase the volume control until the desired signal is heard or the background noise attains a fair level.
- (d) Adjust the tuning control until maximum output from the desired signal is obtained. This insures

correct alignment or proper tuning of the receiver.

- (e) If automatic volume control is desired, switch to the "AVC" position and readjust the volume control for the desired output level.

(3) *C-W Reception*

- (a) The procedure is the same as outlined above with the exception that the c-w oscillator switch is "ON" and tuning accomplished with the beat frequency control set near the zero beat position (arrow on knob pointing up).
- (b) After tuning in the desired signal the beat frequency control may be varied and the frequency of the beat note adjusted as desired.

- (c) Automatic volume control may be employed for c-w reception by switching to the "AVC" position and readjusting the volume control.

- (d) When extreme selectivity is desired to minimize interference, the crystal filter is switched "IN". A slight readjustment of the tuning, beat frequency and volume controls may be required to secure the desired beatnote frequency and volume level.

*NOTE: The crystal band pass filter is intended primarily for use in c-w reception. However, the added selectivity may at times prove helpful in receiving modulated signals through heavy interference.*

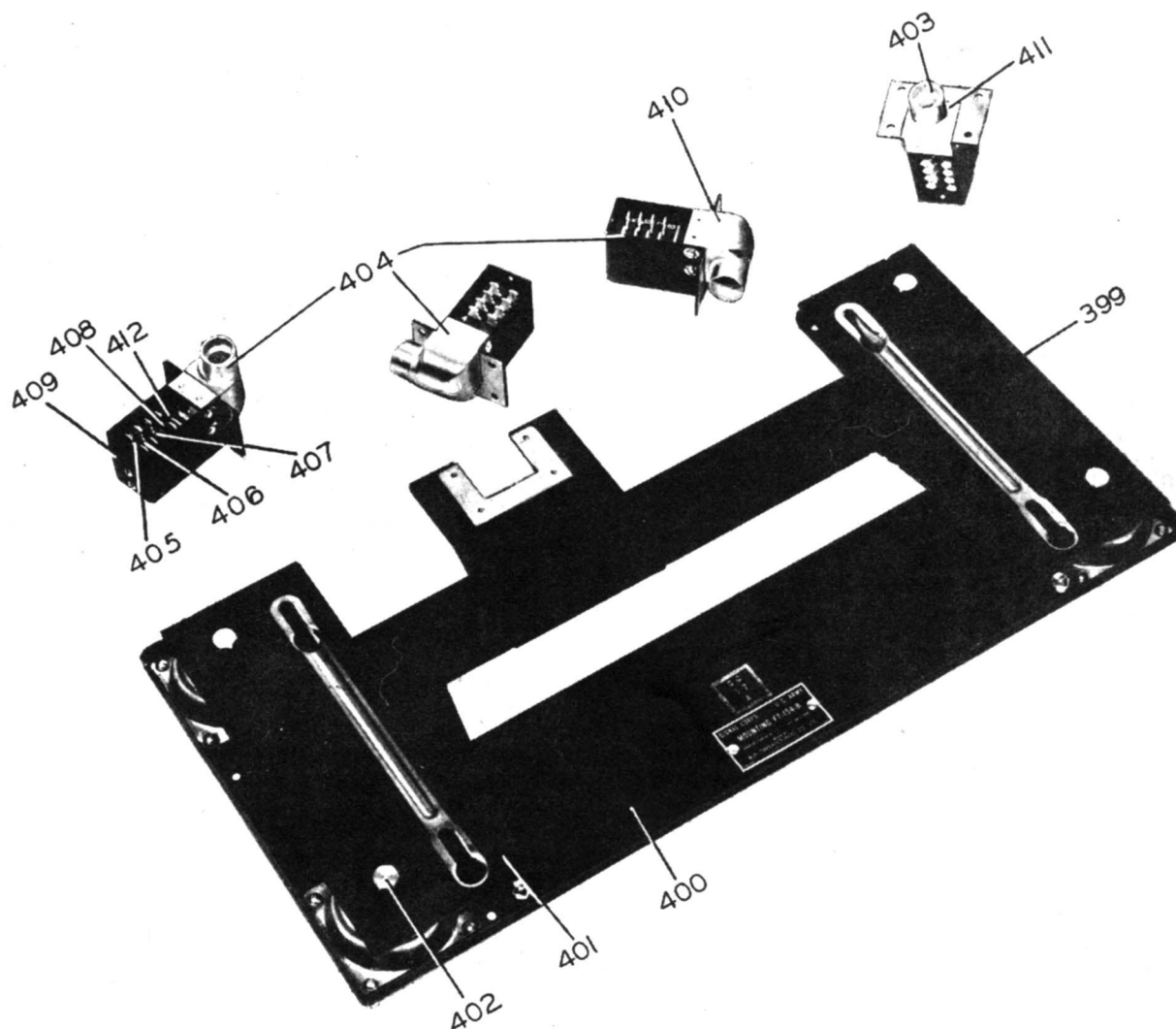

FIGURE 14—MOUNTING FT-154-B AND PLUGS PL-P103 AND PL-Q103

## SECTION III

### DETAILED FUNCTIONING OF PARTS

#### 15 CIRCUITS

Electrically the receiver comprises two stages of tuned radio frequency amplification preceding the first detector, a temperature controlled heterodyne oscillator, three intermediate frequency amplifier stages, a second detector and one stage of audio-frequency amplification with a transformer output circuit. A crystal band-pass filter and beat-frequency oscillator are also included. The former is for increasing selectivity and the latter for receiving C-W signals. The schematic and wiring diagrams are shown in Section V.

#### 16 FREQUENCY RANGE AND FREQUENCY BANDS

The frequency range of 1.5 to 18.0 megacycles is covered in six bands which are under the control of a band change switch. The frequency range for each of the six bands is given in the following table:

Band	Frequency Range Megacycles
1	1.5- 3.0
2	3.0- 5.0
3	5.0- 7.5
4	7.5-10.5
5	10.5-14.0
6	14.0-18.0

#### 17 INPUT COUPLING

The antenna input circuit is capacitively coupled to the first tuned grid circuit by means of the antenna alignment capacitor. Sufficient range is available in this capacitor to permit alignment for antenna capacities within the limits of 50 to 200 micromicrofarads. The antenna input circuit is designed for antennas, the resistance of which is between 1 and 5 ohms.

#### 18 INPUT PROTECTION

The resistor 50-1 provides a leakage path for static charges which may be collected on the antenna. The input circuit will withstand the application of 250 volts d-c without damage. For protection against the application of radio frequency voltages up to 30 volts R.M.S., the input circuit provides for the overshooting of the grid of the first r-f tube and the building up of a protective negative grid bias across the grid filter resistor 48-1.

#### 19 RADIO FREQUENCY AMPLIFIER

The radio frequency preselector comprises three tuned circuits coupled by two Tubes VT-86 (super control pentode amplifier tubes). Separate inductances are employed for each frequency band. The r-f gain of

each of the six bands is kept uniform by selection of the turn ratio between the grid and plate circuit for each of the respective bands. A relatively low signal level is maintained at the grid of the first detector tube, thus insuring freedom from cross modulation interference.

#### 20 FIRST DETECTOR

The first detector employs a Tube VT-91 which has a sharp cutoff characteristic. The low signal level at the grid of the first detector, together with the r-f preselection, insures a minimum of undesired responses. The oscillator output is coupled into the cathode circuit of this tube and separate cathode coupling coils provide optimum oscillator output for each frequency band.

#### 21 HETERODYNE OSCILLATOR

The heterodyne oscillator employs a tuned grid, plate feed back circuit, utilizing a triode Tube VT-65. The effects of wide variations in ambient temperature under service conditions on the oscillator frequency have been reduced to a minimum by the use of a highly stabilized tuning capacitor and temperature compensation with ceramic fixed capacitors (33, 34, 35, 36, 37). Individual inductances and trimmers are employed for each frequency band, and the low impedance coupling circuit to the cathode of the first detector insures a freedom from frequency instability with load variation or detector circuit tuning. On the four lower frequency tuning bands, the oscillator frequency is higher than the desired signal by the intermediate frequency. On the two higher frequency ranges, Bands 5 and 6, the oscillator is on the low frequency side of the desired signal. The latter results in a more uniform tuning ratio over these bands and increases the image rejection ratio.

#### 22 INTERMEDIATE FREQUENCY AMPLIFIER

The intermediate frequency amplifier comprises three low gain amplifying stages coupled by four highly selective, double-tuned circuit transformers. The intermediate frequency employed is 915 kc. The i-f transformers are tuned by means of adjustable iron cores and fixed capacitors. The increased permeability resulting from the use of the iron cores contributes largely to the highly selective transformer characteristics while the lowered tuned circuit impedance, secured by the relatively large fixed tuning capacitors, provides an inherently staple amplifier. A Tube VT-86 functions as the first i-f amplifier while the pentode section

of a Tube VT-70 is employed as the second i-f amplifier. A tube VT-93 as the third i-f amplifier supplies a relatively high level signal to the diodes of this same tube.

**23 C-W OSCILLATOR**

- a The c-w oscillator employs the triode section of the Tube VT-70 (second i-f amplifier tube) in a tuned grid plate feedback circuit. The adjustable iron core in the grid inductance 98 is employed for rough frequency alignment while a small panel-operated beat frequency control permits fine adjustment of the beat frequency within a range of approximately 4,000 cycles each side of zero. The effects of ambient temperature variations are minimized by the use of a temperature compensated tuned circuit. The c-w oscillator operates at an extremely low level minimizing harmonics and stray oscillator pickup. The output is capacitively coupled to the plate circuit of the second amplifier tube by the coupling lead connected to the oscillator grid. Amplification by the third i-f amplifier stage, the gain of which is not controlled either by manual or a-v-c, provides sufficient output from the c-w oscillator to the diode detector. This value of oscillator output is somewhat below the level at which the a-v-c operates, thus permitting the use of automatic volume control even for c-w reception.
- b The c-w oscillator switch 106 in the "ON" position supplies the oscillator plate voltage

and increases the a-v-c time constant by connecting the additional capacitor 101-C. Switch 106 supplies the oscillator plate voltage by connection to the screen grids of the first and second i-f and first r-f tubes. The same switching connects the loading resistor 43-4 which drops the screen voltage to the first and second i-f and first r-f tubes to a value that reduces the sensitivity by an amount sufficient to keep the overall set noise essentially constant. This arrangement for supplying the c-w oscillator has added advantages which are not obvious. In order to have sufficient oscillator excitation available to handle high detector levels encountered with a-v-c operation and strong signal inputs, while still keeping the no signal c-w excitation below the a-v-c delay level, it is desirable to have the c-w oscillator output increase as a strong signal input raises the a-v-c bias. This circuit arrangement, as shown in Figure 15, accomplishes this result, since with switch 107 in the a-v-c position, resistors 42-6, 56, 62 and 59-A form a fixed bleeder supplying the screen grid voltage to r-f, 1st detector and i-f tubes. A strong input signal building up the a-v-c bias causes a considerable decrease in screen current and hence an increase in the screen supply voltage. This increases the voltage supplied to the c-w oscillator and hence the excitation increases in proportion to signal level at the detector.

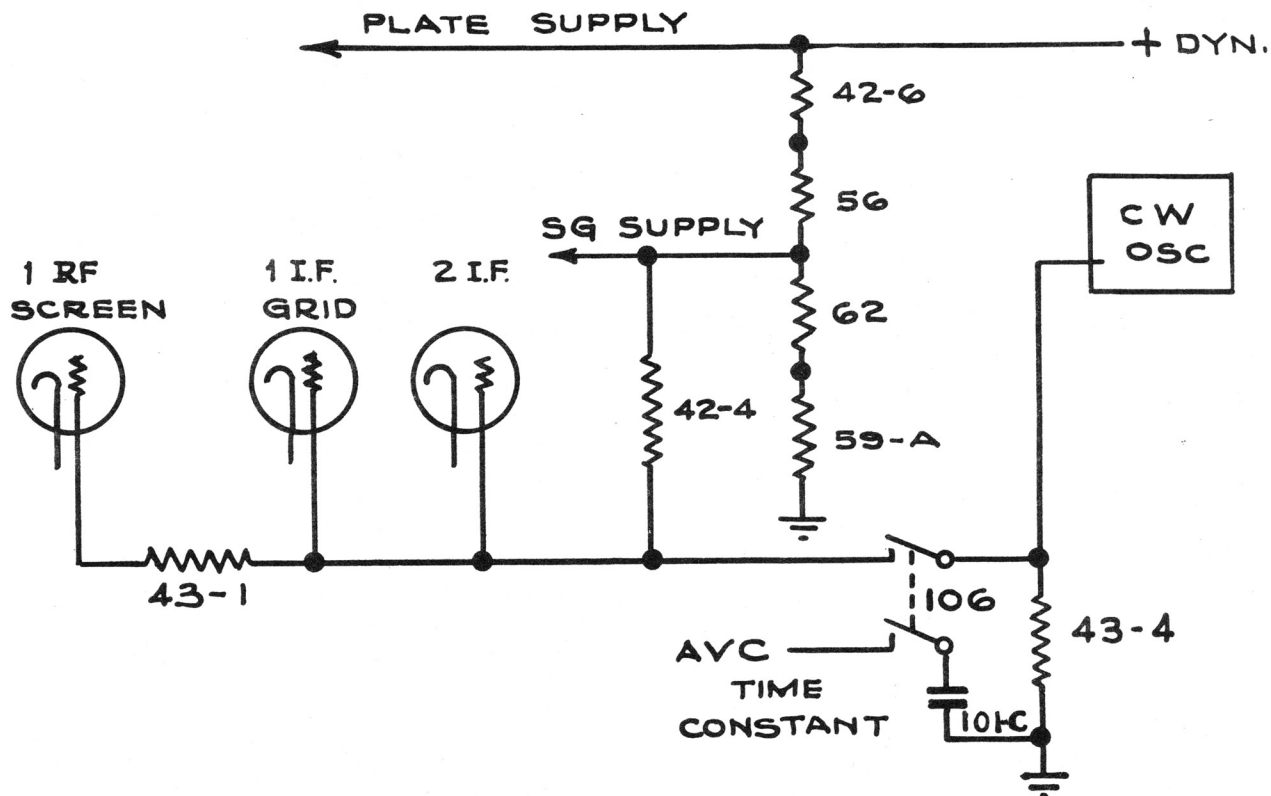

FIGURE 15—C-W OSCILLATOR SWITCHING

## 24 CRYSTAL BAND-PASS FILTER

Additional selectivity is available by the use of the i-f crystal filter preceding the first i-f amplifier tube. This crystal filter comprises a balanced capacity bridge circuit which may be adjusted internally to provide a band width of 800 to 3,000 cycles at 20 decibels down from resonance. The tapped tuned circuit (19 and 96) matches the impedance of the crystal bridge to the 1st i-f grid. The crystal filter may be switched in or out of the circuit by the "Crystal Out-in" switch 105 actuated from the front panel. The filter band width is adjustable by the balancing capacitor 7. As delivered by the manufacturer the band width is set at approximately 2,000 cycles. For adjustment see paragraph 35c (10).

sulting from high audio amplification. The high diode level further provides relatively high bias voltage insuring an unusually flat automatic volume control characteristic with the desired time delay. The dual volume control comprises potentiometers 59-A and 59-B. The latter, 59-B functions only with the switch 107 in the a-v-c position and in this condition it permits the desired adjustment of the audio level to the output tube and load. For manual volume control with switch 107 in the m-v-c position, the potentiometer 59-A becomes the active control operating on the cathode bias of the r-f and the 1st and 2nd i-f amplifier tubes. These potentiometers have two linear resistance tapers providing a smooth variation of sensitivity. Automatic load compensation is obtained by the method of biasing the output tube. Here,

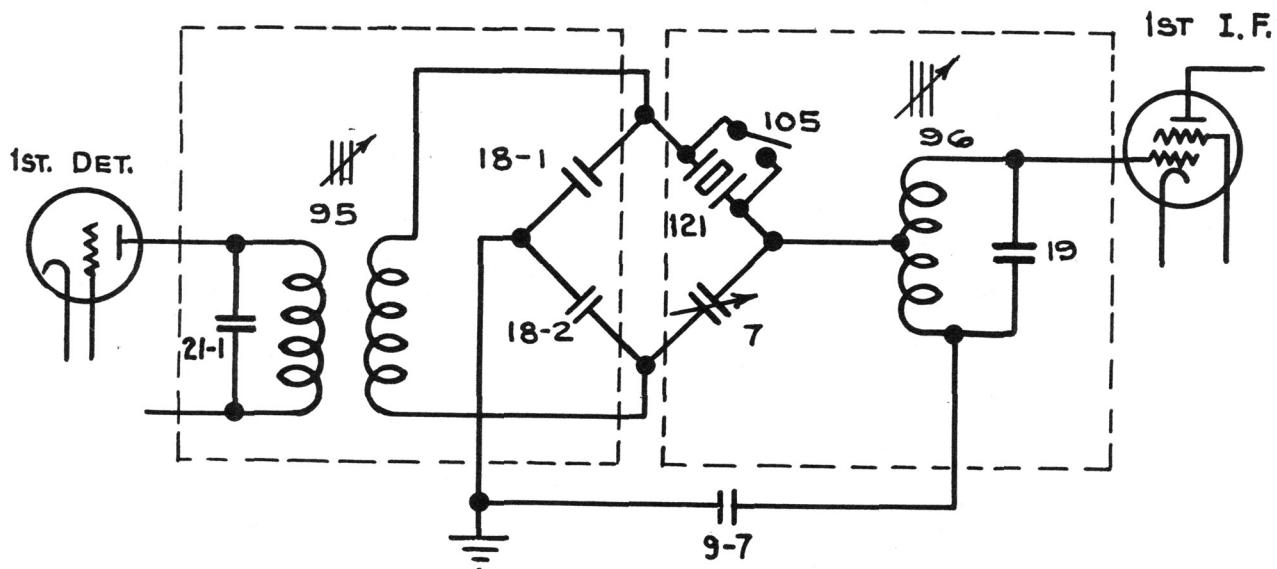

FIGURE 16—DETAILS OF CRYSTAL FILTER CIRCUIT

## 25 SECOND DETECTOR

The Tube VT-93 also functions as the second detector. A relatively high level signal is supplied by the third i-f amplifier to the diodes of this tube. One diode functions as the signal linear detector while the other diode is capacity coupled and provides high level, delayed a-v-c control bias.

## 26 OUTPUT

### a Description

The high level signal diode supplies audio output for driving the VT-48 output tube without additional audio amplification. The design choice of three i-f amplifier stages and high level detection results in a number of operating advantages. The high level detection is relatively free from distortion due to avoiding the characteristic curvature at the lower end of the diode curve. The direct drive of the output tube from the diode detector simplifies the dynamotor ripple filtering and eliminates possible microphonics re-

the grid bias is obtained from the resistance drop across the dynamotor filter reactor, thus, any tendency towards a decreasing load on the dynamotor results in a slight decrease in the bias of the output tube with a compensating increase in the load current. (See Figure 17.) The tube VT-48 provides a considerable margin of power capability above that necessary to operate a number of headsets in parallel.

### b Constant Internal Receiver Noise

The characteristic increase of internal receiver noise when tuning from the low to the high frequency end of a band has been corrected in this design by means of the variable resistor 58. The function of this potentiometer can be more clearly understood by reference to Figure 17. Here the noise compensator 58 is mechanically connected to the shaft of the ganged tuning capacitor with the electrical connections such as to give minimum resistance

at the low frequency end of the band. The cathode return lead of the second r-f amplifier tube connects to the noise compensator 58 and hence the gain of this stage is decreased proportionally as the r-f tuned circuit impedance increases when tuning toward the higher frequency end of the frequency band. This arrangement tends to maintain the noise level and receiver sensitivity essentially constant over the tuning ranges.

### 27 DYNAMOTORS DM-24-B AND DM-28-B

The dynamotor and associated r-f filter circuits are assembled in one unit. The r-f filters are of the unbalanced type for use with a primary supply in which the negative side is grounded. This dynamotor supplies all of the high voltage direct current required for the operation of the receiver and, in addition, a maximum of 20 milliamperes for use in operating accessory equipment.

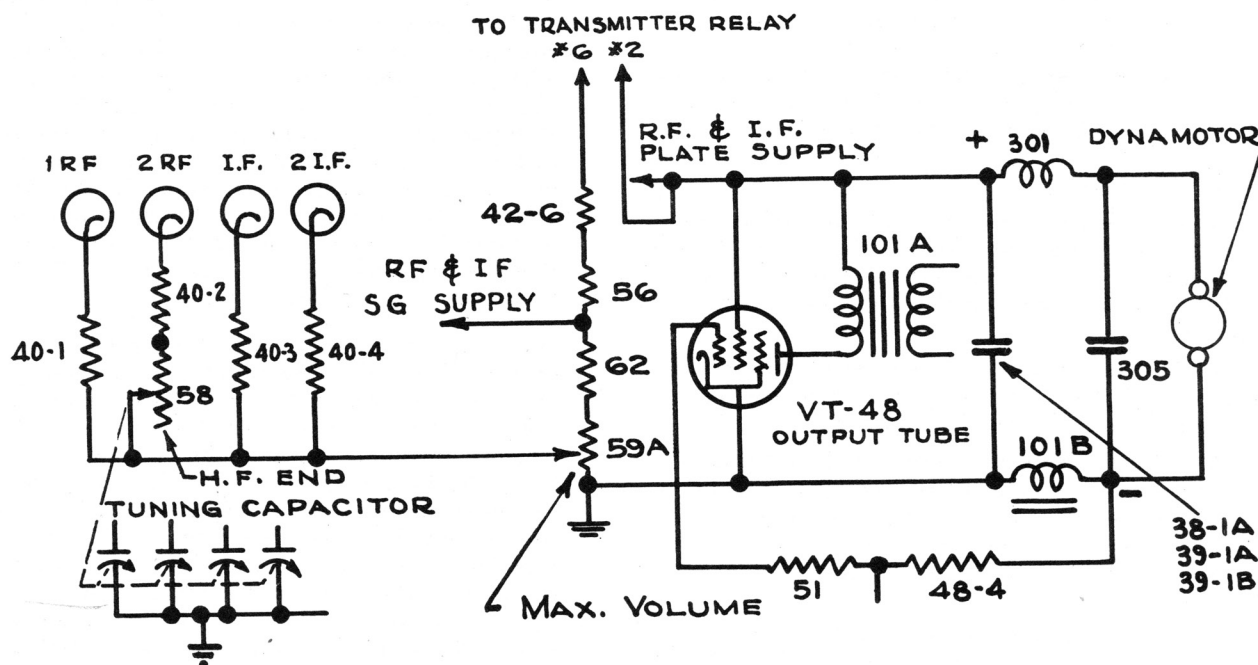

FIGURE 17—LOAD COMPENSATOR AND BLEEDER CIRCUIT DETAILS

### 28 CHARACTERISTICS OF TUBES, LAMPS, VOLTAGE REGULATOR AND FUSE

#### Tube Characteristics

Tube	Heater Volts	Heater Amps.	Screen Volts	Plate Volts	Grid Volts	Plate Ma	Screen Ma	Mu	Plate Resistance Ohms	Transconductance Micromhos
VT-86	6.3	0.3	100	250	-3	7.0	1.7	1,160	800,000	1,450
VT-91	6.3	0.3	100	250	-3	2.0	0.5	1,500	1,500,000	1,225
VT-70	6.3	0.3	100	250	-3	6.5	1.5	900	850,000	1,100
		Tri.	—	100	-3	3.5	—	8	16,000	500
VT-93	6.3	0.3	125	250	-3	10	2.3	800	600,000	1,325
VT-65	6.3	0.3	—	250	-8	8	—	20	10,000	2,000
VT-48	6.3	0.4	250	250	-18	32	5.5	150	68,000	2,200

#### Dial Lamps

Type	Volts	Amps.
LM-27	6.3	0.25

#### Voltage Regulator

RCA-991	Starting Supply Voltage	87 volts min.
	Operating Voltage	60 volts
	Operating Current	0.5 to 2 milliamperes

#### Fuse

Type	Amps.
FU-23	10 for BC-224-B
FU-35	5 for BC-348-B

## SECTION IV MAINTENANCE

*NOTE: No attempt at either mechanical or electrical servicing of this receiver should be made except at Signal Corps Repair Shops and Signal Corps Radio Sections (or Signal Sections) at Air Depots, unless suitable shop and testing facilities are available and authority to repair has been granted by the Corp Area Signal Officer. A standard signal generator, a phantom antenna, a Test Set I-56-A, and other like equipment should be used for alignment purposes and the instructions in this book carefully followed.*

### 29 INSPECTION

- a Daily—Turn on receiver. Check dial lamps. Check for operation on all bands with c-w oscillator "on". This test can best be made by observing noise level with volume control at maximum.
- b 20 Hours—Repeat above with additional check of antenna, ground and cable connections for effects of vibration.
- c 40 Hours—Repeat above with additional check of all vacuum tubes, regulator tube and dial lamps. Inspect receiver for loose grid clips, tube shield, etc. Inspect all tubes with Model 685 Type 2, Tube Checker of Test Set I-56-A.
- d 6 Months—Repeat above with additional cleaning and lubrication of dynamotor as described in paragraph 30.
- e 1 Year—Repeat above with inspection and replacement of dynamotor brushes, if necessary. Lubricate dial and tuning condenser drive mechanism. Check dynamotor and tube socket voltages as described in paragraphs 35c (1) and 35c (3).

### 30 CARE AND SERVICING OF DYNAMOTORS DM-24-B AND DM-28-B

- a The dynamotor and filter assembly is removable from the receiver chassis without disturbing other parts, provided the procedure outlined below is followed:
  - Loosen the two thumb screws on the receiver panel, and draw the chassis from the cabinet.
  - Lay the chassis with top upwards on a smooth, flat surface with the rear toward the operator.
  - Loosen the five connector screws on the dynamotor terminal strip and withdraw the spade terminals from beneath them.
  - Loosen the four captive screws 211, Figure 18, which hold the dynamotor unit to the chassis.

Remove the dynamotor and filter assembly from the receiver by grasping the dynamotor and lifting vertically.

The filter portion of the dynamotor unit is made accessible by the removal of the cover at the bottom. See Figure 18.

This dynamotor requires lubricating after 1,000 hours or approximately 6 months of ordinary service and should be lubricated with none other than Air Corps Grade 375 grease. The directions for lubrication are stamped on the inside of the end-bell dust covers. Access to the bearings of the dynamotor is obtained by first removing the dust covers after cutting the safety wires and removing the retaining screws, then unscrewing the bearing end plates. Do not PACK the lubricant in these bearings.

- b When necessary to replace the ball bearings or turn down the commutators, first remove the brushes from their cartridges. Remove the nuts from the tie rods which hold the bearing end-bells and pull the end-bells away from the field coil assembly. The armature can now be taken out. Examine the brushes to see that they have worn properly and are free from hard spots. Should such spots be apparent (they generally cause grooves in the commutator surface), the brush should be replaced and the commutator smoothed down. The ball bearing retainers and the shaft are machined for very snug fits, but a slight tapping will loosen them. To remove the bearing retainers from the end-bells use two small screwdrivers as wedges between the outer ball race and the end-bell. If the grease slinger becomes bent during removal, it should be straightened and replaced on the shaft before replacing the bearing.
- c To smooth down the commutator rotate it in a lathe holding a fine grade of sandpaper, not coarser than size 00, lightly against the commutator surface. Do not use emery cloth. All residue of dust, sand and dirt should be wiped away to leave a clean, smooth, polished commutator surface. A commutator having a smooth or polished surface should never be sanded or turned down simply because it is discolored. If the commutator is turned down in a lathe, the mica segment separators must be undercut.
- d Re-assembly of the dynamotor is accomplished in substantially the reverse of the disassembly procedure except that the use of the screwdrivers as wedges is not necessary. In replacing the brushes check to see that the + and — markings on the brushes correspond with those on the brush holder sup-

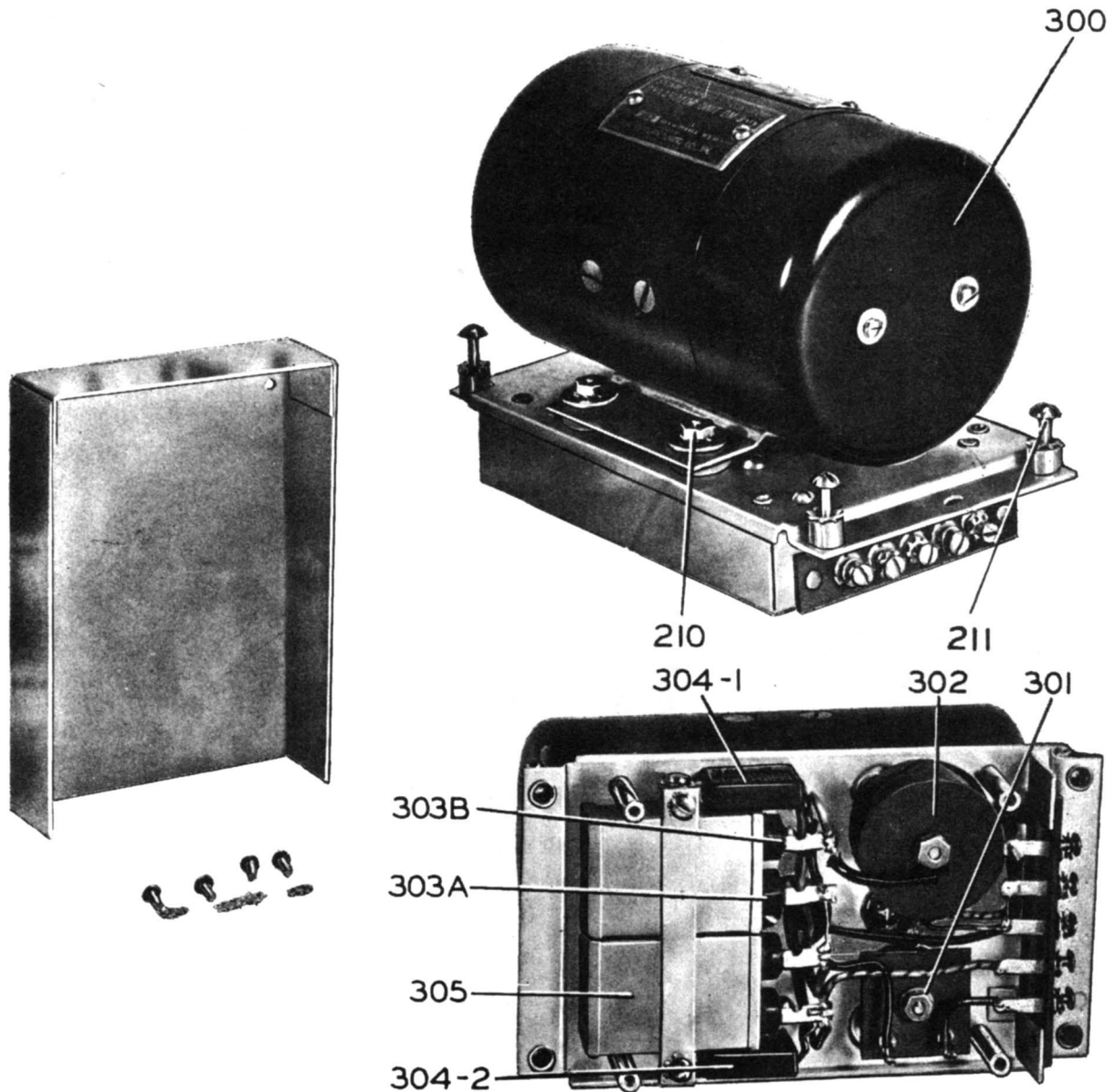

FIGURE 18—DYNAMOTOR DM-24-B AND VIEW SHOWING FILTER OPEN

ports, and that the marked side of the brush is towards the top of the dynamotor. The commutator must be given a final inspection for free running, cleanliness and absence of grease or oil. The end-bells should be wiped clean and dry before replacing them on the dynamotor.

e The nominal rating of dynamotor DM-24-B is: Input, 2.45 amperes at 13.8 volts; Output, 70 milliamperes at 220 volts; Regulation, 12 per cent. Average performance data on Dynamotor DM-24-B is as follows: (dynamotor and filter disconnected from receiver and negative high voltage connection made to case of unit.)

DM-24-B					
Input			Output		
Volts	Amperes		Volts	Milliamperes	
12.0	1.4		213	0.	
12.0	2.0		210	30.	
12.0	2.5		190	60.	
14.0	1.4		255	0.	
14.0	2.2		236	40.	
14.0	2.8		226	75.	



**Pars. 30-31**

f The nominal rating of Dynamotor DM-28-B is: Input, 1.23 amperes at 27.9 volts; Output, 70 milliamperes at 220 volts; Regulation 12 per cent. Average performance data on dynamotor DM-28-B is as follows: (dynamotor and filter disconnected from receiver and negative high voltage connection made to case of unit.)

LIGHTS" control. The retaining nuts of the "TEL" jacks should also be removed. The panel may be lifted off after the removal of the end plate holding screws, the chassis holding screws, the dial casting holding screws and a screw which supports the crystal filter assembly to the panel.

Input		DM-28-B		Output	
Volts	Amperes	Volts	Milliamperes		
24	0.7	215	0.		
24	1.1	210	30.		
24	1.3	202	60.		
28	0.8	258	0.		
28	1.1	246	40.		
28	1.5	236	75.		

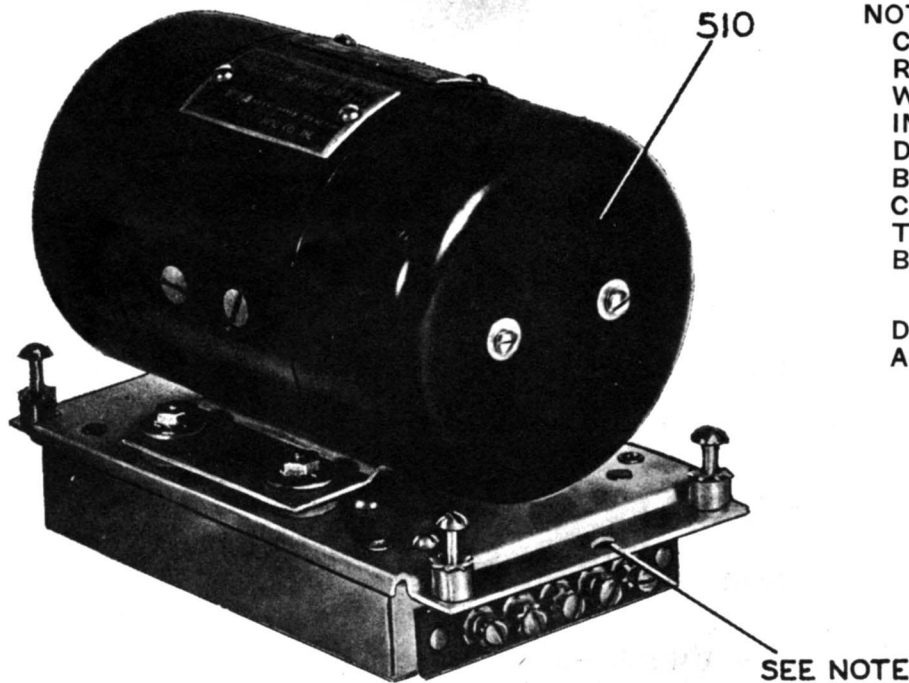

NOTE: DOWEL PIN ON CHASSIS OF RADIO RECEIVER BC-348-B, WHICH FITS IN HOLE IN DYNAMOTOR DM-28-B MOUNTING BASE, PREVENTS ACCIDENTAL INSTALLATION OF DM-24-B IN BC-348-B.

THE FILTERS FOR DM-24-B AND DM-28-B ARE IDENTICAL.

FIGURE 19—DYNAMOTOR DM-28-B

**31 REMOVAL OF FRONT PANEL**

a For adjustment of dial or mask, or for servicing of certain parts, it may become necessary to remove the panel. The chassis, with panel attached, should be taken completely out of the cabinet and placed for inspection with the panel facing upwards. Unsolder the lead to the antenna binding post and the lead from the chassis to the dial lights. Remove the dial light housing cover, the two thumb screw rods, the handles, and all knobs and retaining nuts of all controls except the "DIAL

b In replacing the "BEAT FREQ." control knob turn the flexible shaft until the set screw in the coupling at the internal end points away from the panel. Now mount the knob so that the arrow points vertically towards the top of the receiver. This knob has two set screws. In replacing the other knobs on the shafts, it will be noted that flats on the shafts provide for proper location. All set screws must be securely tightened, and the set screw on the band switch knob in particular should be given a second tightening after the shaft has been rotated a few times.

**32 DIAL AND MASK ASSEMBLY**

- a Attached to the front panel, and to the main frame or chassis casting, is an aluminum casting which is the frame for the switch drive shaft, dial mask and detent, and also for the tuning dial, tuning shaft, reduction gears and stop. All of these parts are assembled, and can be moved, as a unit, which simplifies any service operations which might be required.
- b The switch drive shaft passes through a hole in an adjustable plate located in the dial lamp housing and through a clearance hole in the panel. The hole in the adjustable plate is purposely given a larger clearance than bearing requirements would dictate, since its use is to support the shaft against forces which might spring it or damage the internal bearing. The shaft extends through a long bushing pressed in the dial housing. At the inside end of the shaft, the detent (star wheel) and the driving portion of the coupling member are pinned in place by means of taper pins. The dial assembly runs on the outside surface of the long bushing referred to above. Just inside the panel the shaft has

- attached to it by taper pin, the hub of the mask.
- c On the back of the dial frame casting is a stop arm which engages a pin in the detent so as to limit its rotation to 6 positions which are spaced 60 degrees apart. There is attached the assembly of pivot pins, arms with rollers, and spring which positions the detent. This assembly is locked with two dowel pins after the correct location is made.
- d On the front (panel) end of the bushing through which the switch shaft passes there is a narrow shoulder which supports the lower end of the dial index plate. This index plate is attached to the casting at its upper end with means for removing any slack and keeping it straight and taut. The inner end of the mask hub and the outer end of the dial hub turn and are held against opposite sides of the index plate.
- e The dial is attached to a flange on a hub which runs on the outside surface of the bushing through which the switch drive shaft passes. This hub also carries a large gear which is driven by a pinion combined with a

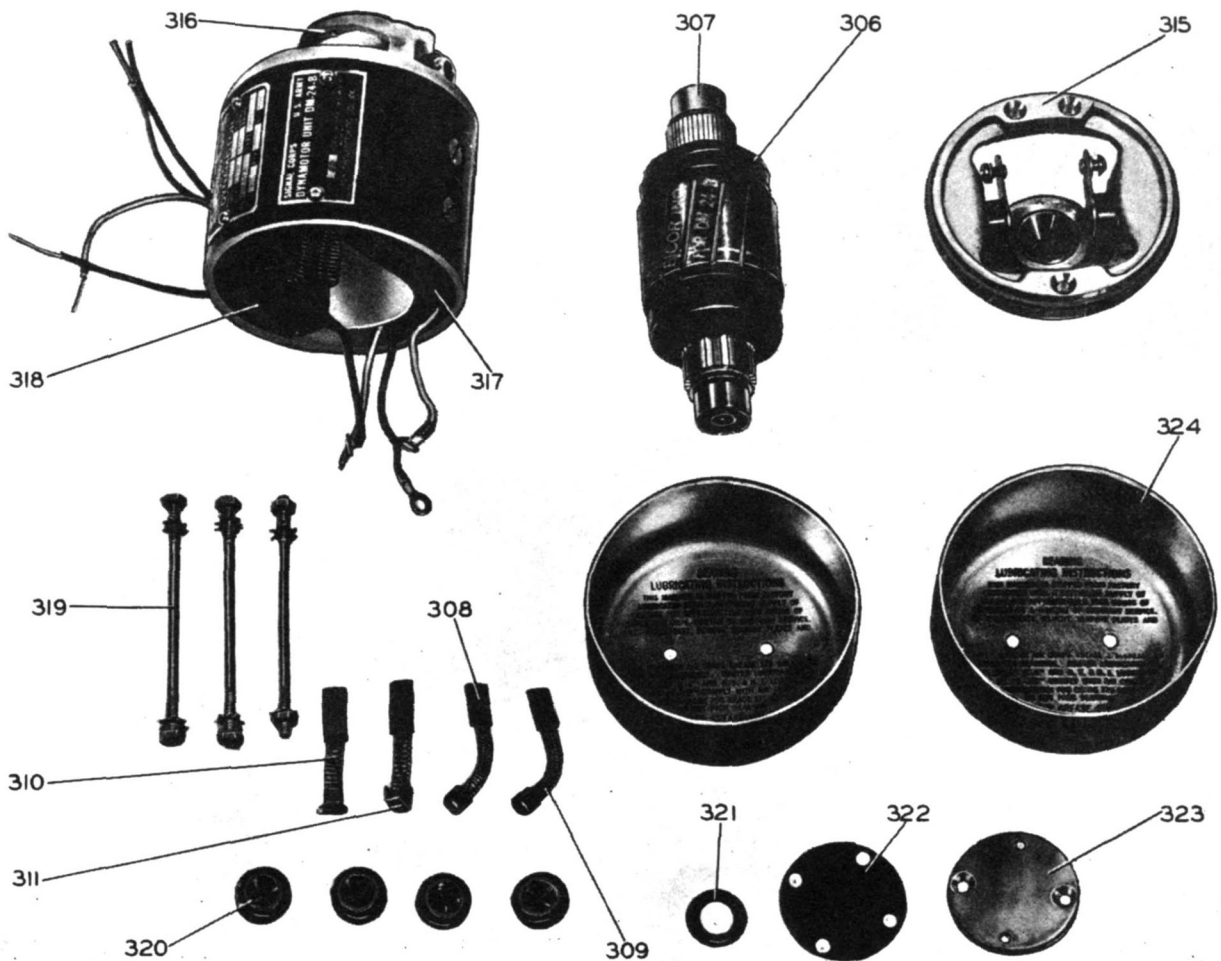

FIGURE 20—DYNAMOTOR DM-24-B, DISASSEMBLED

Par. 32

split idler gear. This split idler gear and pinion has adjustment in the clearance holes for the mounting screws to enable the backlash in the mesh of the pinion with the large dial gear to be reduced to the smallest practicable amount when assembling.

- f The tuning shaft has, in addition to the pinion referred to above, a stop, and a worm which meshes with a split worm gear on a cross shaft at the back of the frame. Both this cross shaft and the tuning shaft run in bearings which are integral in the casting. Both shafts have spring thrust washers to remove end play. The cross shaft carries a pinion which is meshed with a split gear on the tuning capacitor shaft at assembly. The degree of mesh of this pinion and gear is adjustable by moving the tuning capacitor toward or away from the panel after it is placed in position and before the holding screws are finally tightened.
- g The overall gear ratio between the tuning shaft and the capacitor shaft is 200 to 1. Since the design of the tuning capacitor per-

mits but a small amount of rotation at either end of its travel beyond the 180 degrees required to give its complete range in electrical capacity, means are provided to stop the tuning shaft at either end of a total of approximately 100 revolutions. This is accomplished by a cam on the outer edge of the tuning dial which operates an arm pivoted on a pin on the frame casting. One end of this arm has a roller which runs on the outer edge of the dial. The roller is held in contact with the dial by a spring. The dial periphery is cut away in such a manner that when the point corresponding to either end of the tuning capacitor travel is reached, the roller, and therefore the end of the arm, can move toward the center of the dial, being forced in that direction by the spring. Thus the opposite end of the stop arm is moved so that the hook at the end of the arm engages the rotating stop on the tuning shaft and the shaft is thereby prevented from further turning. When the direction of rotation of the tuning shaft is reversed, the roller and arm are

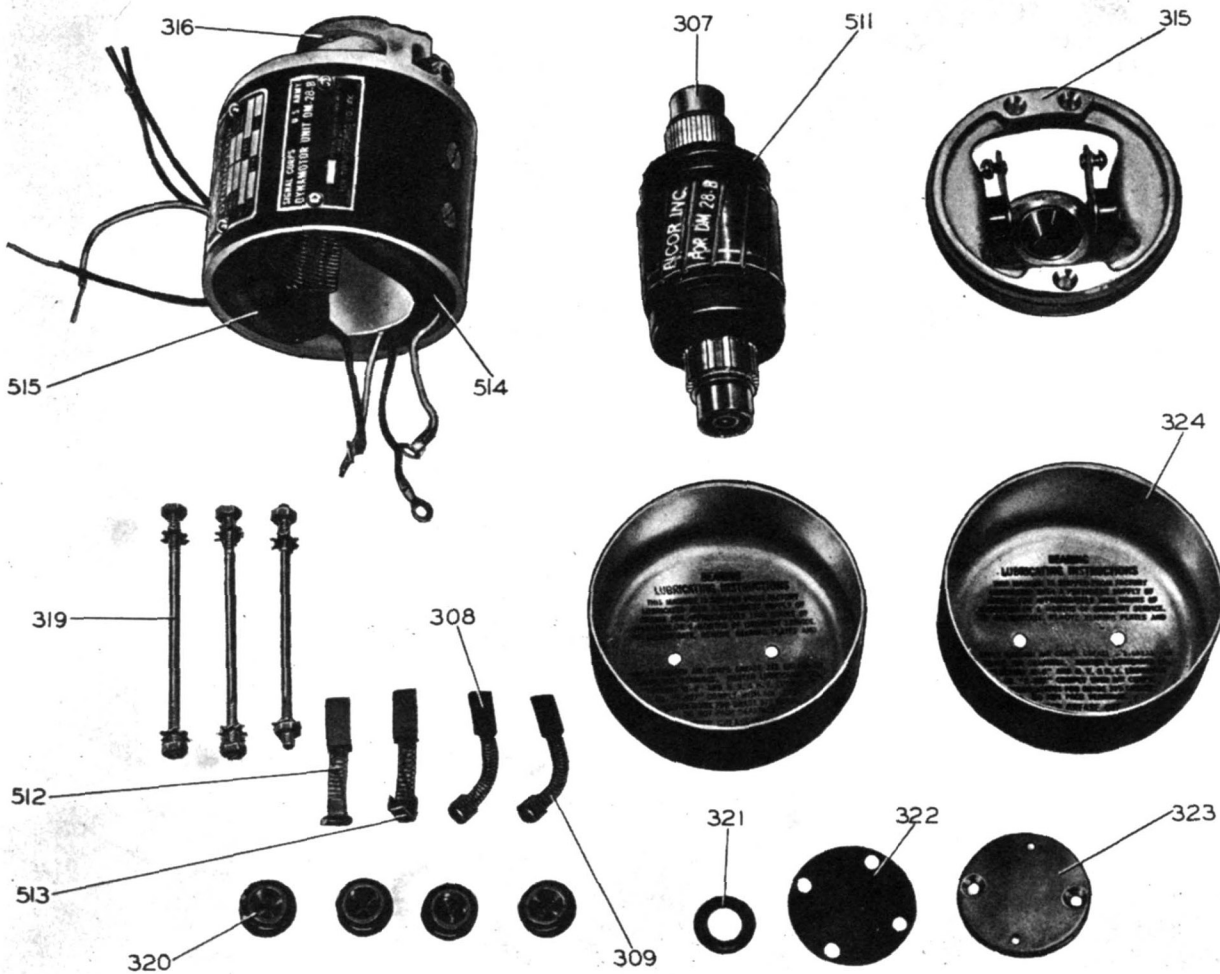

FIGURE 21—DYNAMOTOR DM-28-B, DISASSEMBLED

pushed outward against the spring by the cam edge of the dial and the stop disengages.

- h* Since a definite relation must be set and maintained between the dial position and the angular position of the rotor of the tuning capacitor, adjustment is provided at the pinion on the cross shaft at the rear of the frame. (This is the shaft which also carries the worm gear.) This pinion is held in place by two set screws which bear in a groove on the shaft. By loosening these two set screws, either the dial or the tuning capacitor can be rotated while the other part remains fixed. The correct relation between these is that the tuning capacitor rotor plates are fully meshed with the stator plates (maximum capacity) when the dial is set with the isolated index mark at the low frequency end of the "14.0-18.0 MC." band in line with the index.

### 33 REMOVAL AND REPLACEMENT OF DIAL MECHANISM

- a* In the event that the dial mechanism is to be removed from the chassis for any servicing operations, it is necessary first to remove the front panel in accordance with instructions given earlier in this book (par. 31). The frame of the mechanism is attached to the chassis by the bracket holding the fuse, and by two slotted hexagon head screws through the flange on the under side of the chassis. Note that one of these screws is beneath the removable shield which covers the terminal of the first i-f transformer. When these screws are removed, the complete unit can be removed. The center disc of the flexible coupling is loose and will drop out of engagement.
- b* To remove the index and dial, the taper pin holding the mask hub to the switch drive shaft must be removed. It is necessary to support the shaft when driving out this pin so that excess stress will not be placed on the center bushing. After the removal of the mask and the index, the dial and its gear are free to slide off the bushing. In replacing these parts, the thrust washer behind the dial hub must be turned in the position to give maximum thrust, which is convex side outward.
- c* If the dial is removed and replaced, it is possible that in meshing the dial gear with the idler gear the stop relationship may not be correct, in which case it may be necessary to change a tooth at a time to correct. The stop relationship must be such that the roller arm hook and the tuning shaft stop arm engage fully at the end of the last revolution, but on the previous revolution the arm must not start to move until after the rotating arm has passed under the roller arm hook. This adjustment can only be made by trial and inspection, but it can be secured in one or two trials. Substitution of a different stop arm

may also require re-adjustment, but in this case the adjustment should be made by lengthening or shortening the roller end of the arm. This is done by loosening the two nuts on the arm, after which the arm can be adjusted by the slotted holes provided.

- d* When the dial mechanism is replaced, the flexible coupling must be properly positioned so that the position of the mask corresponds to the switch position, since it is possible otherwise to get the band switches to an in-operative position. The correct relative positions are obtained when the mask is set to band "1.5-3.0 MC." and the set screw locking the flat switch shaft to the large bevel gear hub is 15 degrees back (away from panel) from vertical.
- e* If any of the gear trains including split gears have been un-meshed in disassembly, the split gears must be reset to put tension on the loose section when they are again meshed. Normally a displacement of one tooth between the two sections is sufficient. Trial will show whether this will remove the backlash.
- f* When the dial mechanism is re-assembled to the chassis, the relation between the dial and the tuning capacitor must be carefully adjusted in order to maintain the calibration and prevent over-running the capacitor (Refer to paragraph 32*h*). This is done by loosening the two set screws in the pinion on the cross shaft on the back of the dial assembly. Before putting the mechanism in place, this pinion can be moved along the shaft toward the worm gear so as to clear the capacitor split gear. This facilitates assembly, since the gears can be meshed after the dial mechanism is bolted in place, making it easier to get the tension on the split gear in the capacitor assembly.

### 34 REMOVAL OF ANTENNA, R-F, DETECTOR AND OSCILLATOR UNITS

In many cases servicing of these units will require only the removal of the top or bottom cover of a particular unit; however, any unit may be removed and replaced independently as follows:

- (1) Unsolder the lead to the main tuning capacitor at the capacitor by first removing the capacitor shield. Unsolder all other leads at the unit.
- (2) Disconnect the band switch drive shaft and withdraw same from the antenna unit end.
- (3) In case of antenna unit, disconnect the antenna alignment control shaft.
- (4) Remove screws holding unit to the tie strips at the bottom.
- (5) Remove screws holding the unit to the chassis.
- (6) Lift the unit from the receiver, taking care that it comes out freely.

When replacing a unit reverse the above procedure; however, do not tighten the chassis holding screws tightly until the drive shaft has been replaced and the band change switch knob has been rotated a number of times. This will insure the self-alignment of the unit and the proper action of the detent.

### 35 TROUBLE LOCATION AND REMEDY

#### a General

The normal sensitivity (number of microvolts input to produce 10 milliwatts output into a 4,000-ohm resistance load) of the receiver is better than 3 microvolts when measured under the following conditions:

"AVC-OFF-MVC" switch at "MVC"; 14 volts input in the case of BC-224-B. (28 volts input in the case of BC-348-B); c-w oscillator "ON"; crystal filter "OUT"; output load 4,000 ohms non-inductive resistance; pure c-w input from signal generator applied between antenna-ground terminals through a 100-mmf dummy antenna; volume control set to produce 1 volt noise output.

This sensitivity will, of course, be subject to variation with time due to tube aging, etc. **Therefore, it is recommended that no attempt be made to retrim or realign the equipment unless the sensitivity is found to be worse than 7 microvolts with new, average tubes.**

This receiving equipment has been carefully adjusted and aligned by the manufacturer before shipment and should maintain these adjustments over reasonably long periods of time. Major adjustments and repairs should be made only in an authorized repair shop equipped with the necessary servicing tools and equipment. **All others must refrain from changing any of the adjustments of the radio frequency circuits.** The difficulties usually experienced are the result of external deteriorating influences, such as worn-out vacuum tubes, improper operating voltage, blown fuse, external noises, etc. However, in order to permit the servicing of this equipment, the testing procedure shown should be followed in determining the sources of trouble. This has been divided into the following major divisions, with respect to the nature of the troubles being experienced:

- Equipment required—See paragraph 35b.
- Weak or No signals on all bands—Modulated reception—See paragraph 35c.
- Weak or No signals on any one band—Modulated reception—See paragraph 35d.
- Weak or No signals on all bands—C-W reception (modulated reception normal)—See paragraph 35e.

The following graphically outlines the procedure for trouble location, the numbers in each block referring to the paragraph numbering in the following discussion:

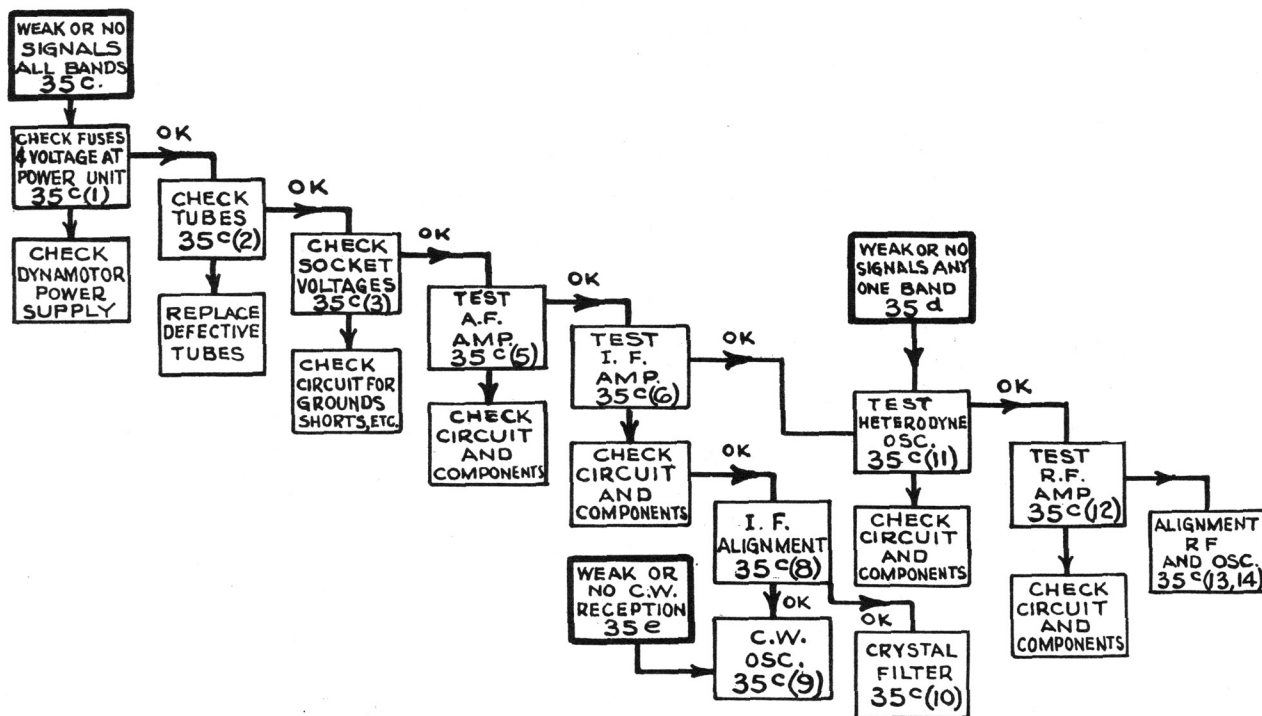

FIGURE 22—TROUBLE LOCATION AND CORRECTION CHART

**b Equipment Required**

Few instruments other than those found in a standard set analyzer (Test Set I-56-A) are required in locating the most probable troubles in this receiver. The individual instruments required are as follows:

- (1) A modulated test oscillator (standard signal generator) with a frequency range from 900 to 18,000 k.c. with provision for calibration accuracy better than 0.1% at aligning frequencies.
- (2)\* Voltmeter — 1,000 ohms per volt, ranges: 0-10; 0-100; 0-250 volts.
- (3)\* Continuity tester.
- (4)\* Output meter rectifier type, 0-15 volt, 4,000 ohms.
- (5) Microammeter, 0-200.
- (6) Audio frequency oscillator.
- (7) Pair of telephone receivers.
- (8) An Adaptor, FT-211 consisting of an 8-prong octal plug, and an 8-prong octal socket connected together by a short length of 8-conductor cable, to permit use of the Test Set I-56-A Analyzer on the r-f tubes on the tube shelf.

\*Part of Test Set I-56-A.

**c Weak or No Signals on All Bands, Modulated Reception**

**(1) Check of Dynamotor Voltages**

When all signals on all bands are weak

or no signals are heard even when known to be present, the procedure follows that shown in the chart. The voltages checked at the dynamotor terminal board should closely approximate the values shown in Figures 23 and 24 for the BC-224-B and BC-348-B respectively. Conditions of measurements are as follows:

Input voltage 14V. for BC-224-B (28 volts for BC-348-B); Crystal "Out"; "MVC"; Volume Max.; C-W Osc. "Off"; Load 4,000 ohms resistance.

If these voltage readings do not approximate the values shown, the fuse should be checked as well as the dynamotor and filter circuits, wiring and components.

**(2) Tube Check**

If the voltages at the dynamotor terminal board approximate the values given, proceed to check all tubes for emission and characteristics or replace all tubes with those of known average characteristics.

**(3) Check of Socket Voltages**

If tubes check satisfactorily, or if after replacing with tubes known to be good, the sensitivity is still low, proceed to check all tube socket voltages as outlined under paragraph 35f with Test Set I-56-A. The average socket voltages for the BC-224-B and BC-348-B are given in the following Figures 23 and 24 respectively.

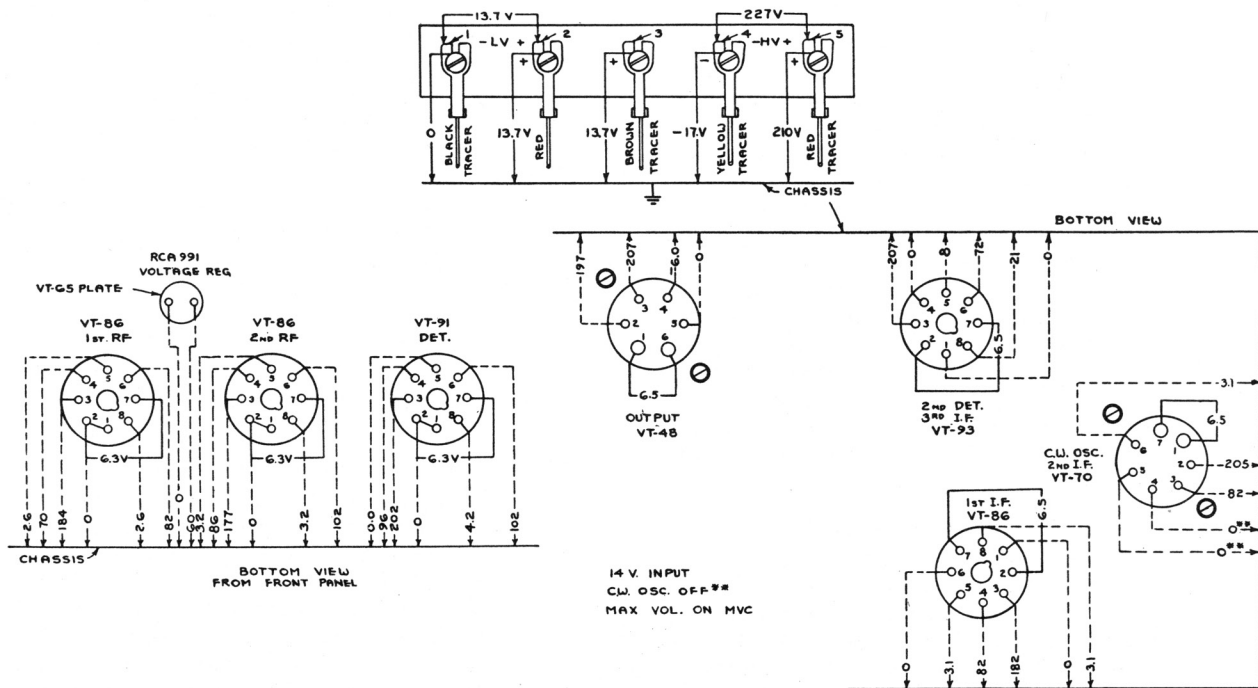

FIGURE 23—RADIO RECEIVER BC-224-B: DYNAMOTOR AND TUBE SOCKET VOLTAGES

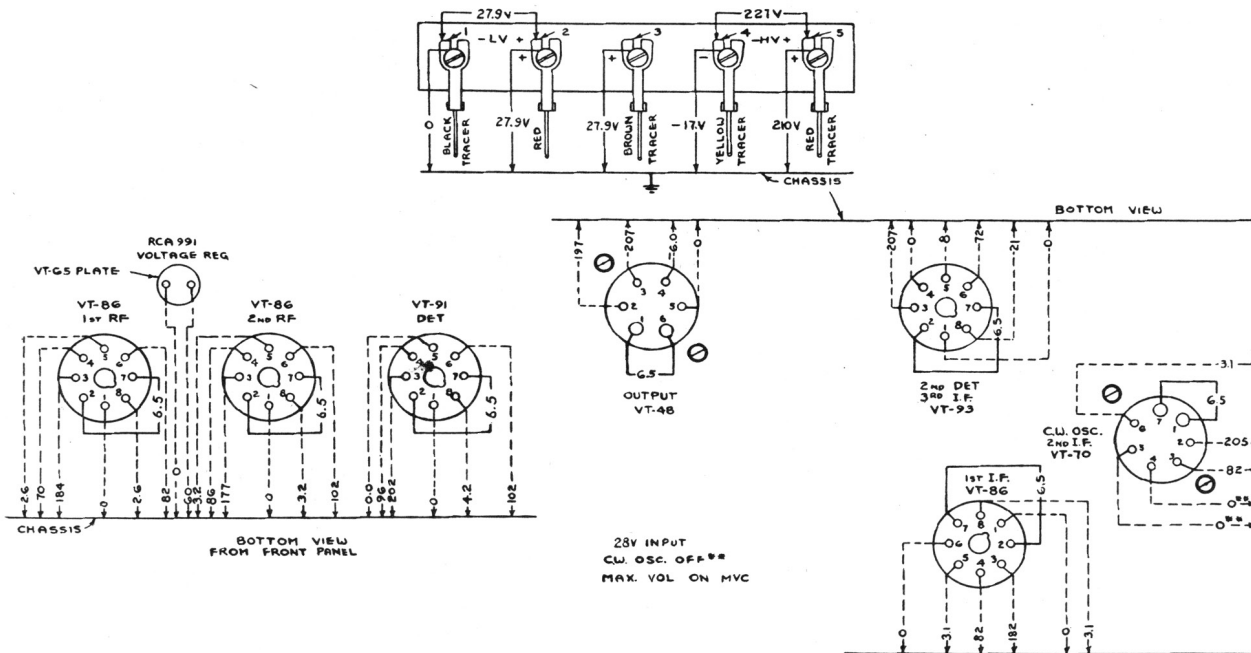

FIGURE 24—RADIO RECEIVER BC-348-B: DYNAMOTOR AND TUBE SOCKET VOLTAGES

(4) *Check Circuit Wiring and Components*

If the tube socket voltages do not approximate the values shown in Figures 23 and 24, the associated circuits and components should be checked for grounds, shorts and similar defects.

(5) *Test of Audio-Frequency Amplifier*

Having checked all socket voltages and found the values to be correct, proceed to the test of the audio frequency amplifier. This can be checked by capacitively coupling a 400-cycle voltage of approximately 2 volts R.M.S. from ground to the detector diode socket prong to ground using a capacitor of 0.5 mfd. As an alternative, a modulated 915 kc signal of 2 volts may be coupled to this point and ground. Proper functioning of the audio amplifier will be indicated by an output well over 10 milliwatts for the 2 V. audio input or approximately 1 milliwatt output for 915 kc input. Circuits, wiring and components should be checked if this order of response is not obtained.

(6) *Test of Intermediate-Frequency Amplifier*

Following a satisfactory test of the audio amplifier, check the intermediate frequency amplifier by capacitively coupling the modulated test oscillator to the grid cap of the first detector tube and ground, through a 0.1 mfd. capacitor, the frequency being adjusted

to 915 kc. A rough check of the proper functioning of the i-f amplifier is indicated by a comfortable headphone output level with low input from the test oscillator. (Approximately 25 microvolts input for 10 milliwatts output.)

(7) *I-F Amplifier Circuit Check*

If the i-f amplifier does not respond as above or lacks sensitivity, a progressive check, stage by stage, should be made. The test oscillator, 915 kc. modulated input, is connected through a 0.1 mfd. capacitor to the second detector diode socket prong and to ground. A signal response indicates proper functioning. Coupling the test oscillator to the grid of the third i-f should indicate a decided gain in sensitivity. Proceeding similarly towards the first detector, each stage should show a decided gain, and a faulty stage can be circuit checked for grounds, shorts, or defective components.

(8) *Alignment of I-F Amplifier*

When all stages have been tested, the i-f amplifier alignment is checked by capacitively coupling a low level input signal of 915 kc to the first detector grid and adjusting the i-f tuning cores of both primary and secondary windings of the first, second and third i-f transformers and the tuned circuit of the crystal filter assembly for maximum output. The fourth i-f trans-

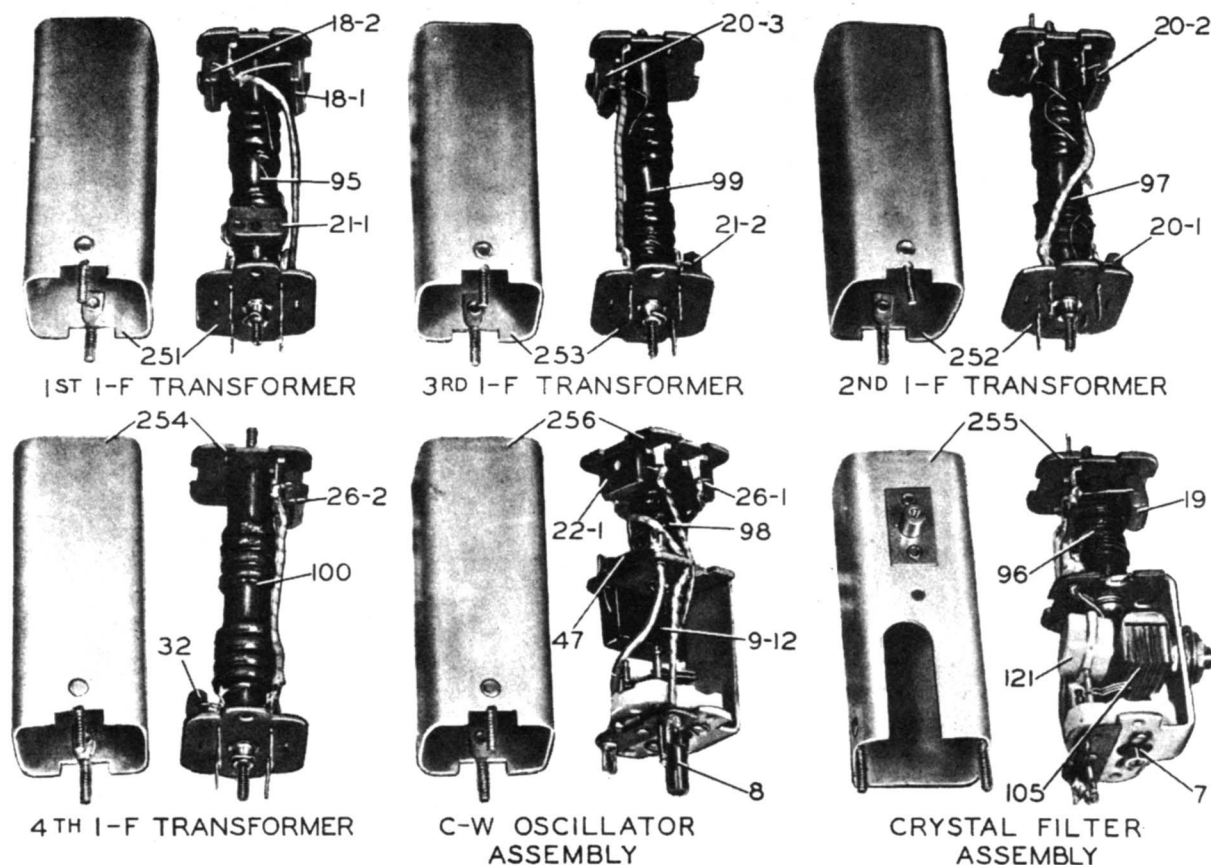

FIGURE 25—I-F TRANSFORMERS, C-W OSCILLATOR, AND CRYSTAL FILTER ASSEMBLIES

former is slightly over-coupled with the resultant double response peaks symmetrically located approximately 5 kilocycles each side of the 915 kc i-f alignment frequency. In general, it will not be necessary to realign this transformer because of its broad characteristic. However, if realignment becomes necessary the following procedure should be followed:

Connect the modulated test oscillator through a 0.1 mfd. capacitor to the grid of the Tube VT-93 (third i-f amplifier tube) and to ground. Set the input frequency at 910 kc and adjust alternately first the primary tuning core, then the secondary tuning core of the fourth i-f transformer until maximum output is obtained when both cores are turned in a right-hand screw direction. The modulated test oscillator should then be turned slowly through the 915 kc setting and to approximately 920 kc where a second response peak of approximately equal amplitude as that at 910 kc should be obtained. This indicates correct alignment. Slight supplementary adjust-

ments of the primary and secondary tuning cores may be necessary to secure a symmetrical double peak response with the slight hollow between response peaks located at the 915 kc alignment frequency. If a sweep frequency modulated test oscillator is available, this fourth i-f transformer can be conveniently aligned by visual observation on a cathode ray oscilloscope. In this case, the tuning core adjustments are made to obtain a double peak response pattern centered at 915 kc.

(9) *Check and Alignment of C-W Oscillator*

The c-w oscillator is checked and adjusted by coupling the 915 kc input (modulation off) to the grid of the first detector tube and then switching the c-w oscillator "ON". With the beat frequency control set at mid-position, the oscillator inductance tuning core 98 is adjusted for zero beat. If no c-w beat can be heard, the c-w oscillator circuit should be checked for grounds, shorts, or defective components. With the c-w oscillator



Par. 35

"ON" the screen voltage at the first and second i-f sockets drops to approximately 45 volts (measured to ground).

(10) *Test and Adjustment of Crystal Band Pass Filter*

Normally the crystal band pass filter is adjusted at the factory for a band width of 1,500 to 2,000 cycles at 20

frequency of the test oscillator should be slowly varied until the response peak of the crystal filter is located. The signal input voltage or the volume control (MVC) should then be adjusted to give a reading of approximately 70 microamperes on the response peak. Switching the crystal filter "OUT" should not produce a

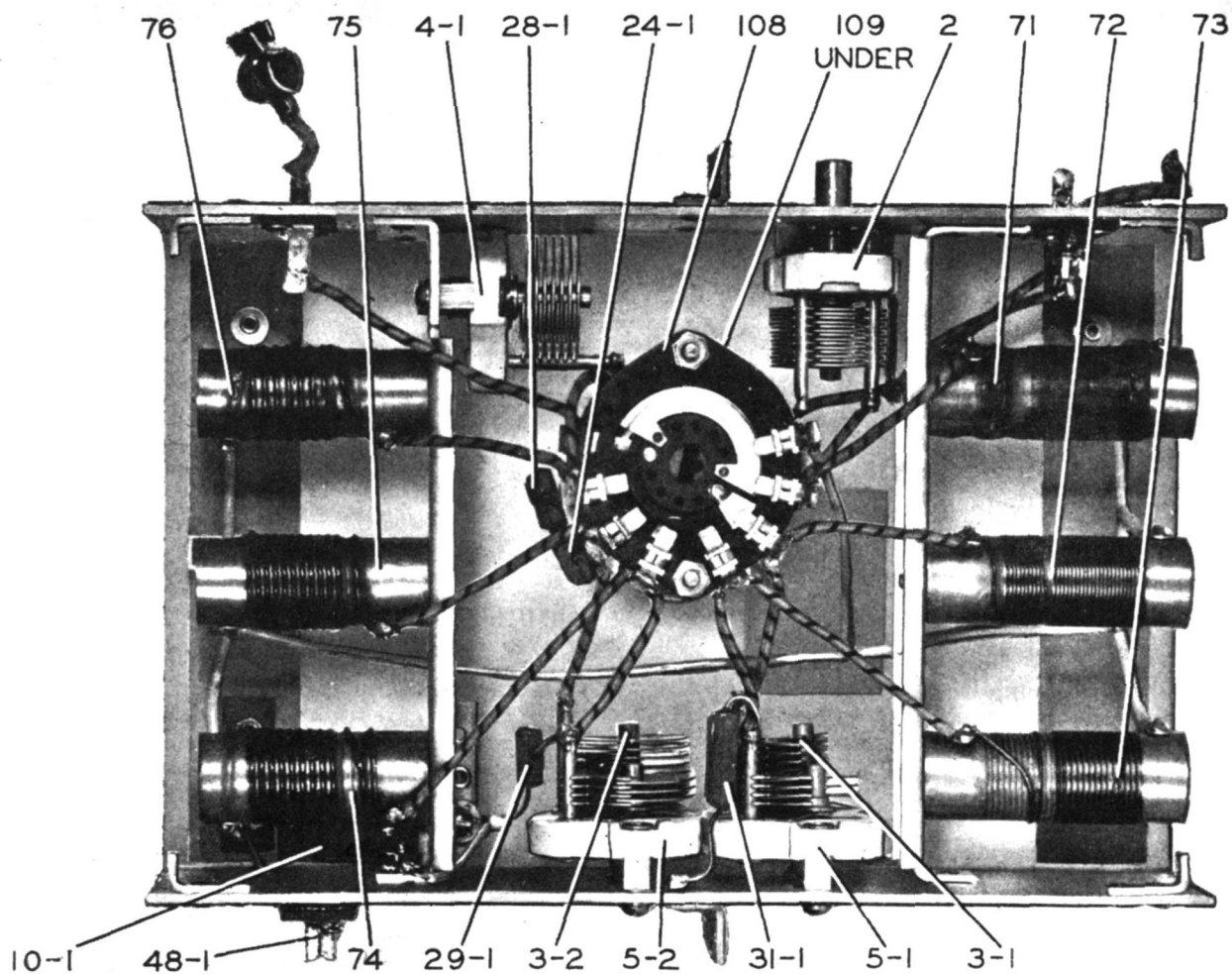

FIGURE 26--ANTENNA UNIT

db down from resonance. This filter can be tested by applying an unmodulated signal of approximately 915 kc, connected through a 0.1 mfd capacitor to the grid of the first detector tube and ground. With the crystal filter switch "IN", and a 200-microampere meter connected in the lead from the volume control 59-B to the cathode of the third i-f amplifier Tube VT-93 (available at the bottom terminal of the rear volume control), the fre-

quency of the test oscillator should be slowly varied until the response peak of the crystal filter is located. The signal input voltage or the volume control (MVC) should then be adjusted to give a reading of approximately 70 microamperes on the response peak. Switching the crystal filter "OUT" should not produce a reading of more than 110 microamperes. This test indicates the correct functioning of this filter. The c-w oscillator should be off during this test. To adjust the band width of the crystal filter, a signal generator or microvolter having an expanded tuning scale in the vicinity of 915 kc and having also an attenuator with a multiplier of 10 times (20db) is required. The following procedure is recommended: With the signal input tuned to the crystal filter

response peak (Crystal "IN") and a output reading of 100 microamperes, the attenuator is set to multiply the input voltage by 10 times and the signal generator detuned on each side of resonance, noting the frequencies of the points where a reading of 100 microamperes is again obtained. From the difference of these frequency readings, the crystal filter bandwidth can

denser settings near maximum or minimum capacity (adjustment slot parallel to front panel). After concluding the above-described tests, remove the microammeter and restore the circuit to normal.

(11) *Check of Heterodyne Oscillator*

Having checked the functioning of the i-f and audio amplifiers, if signals are

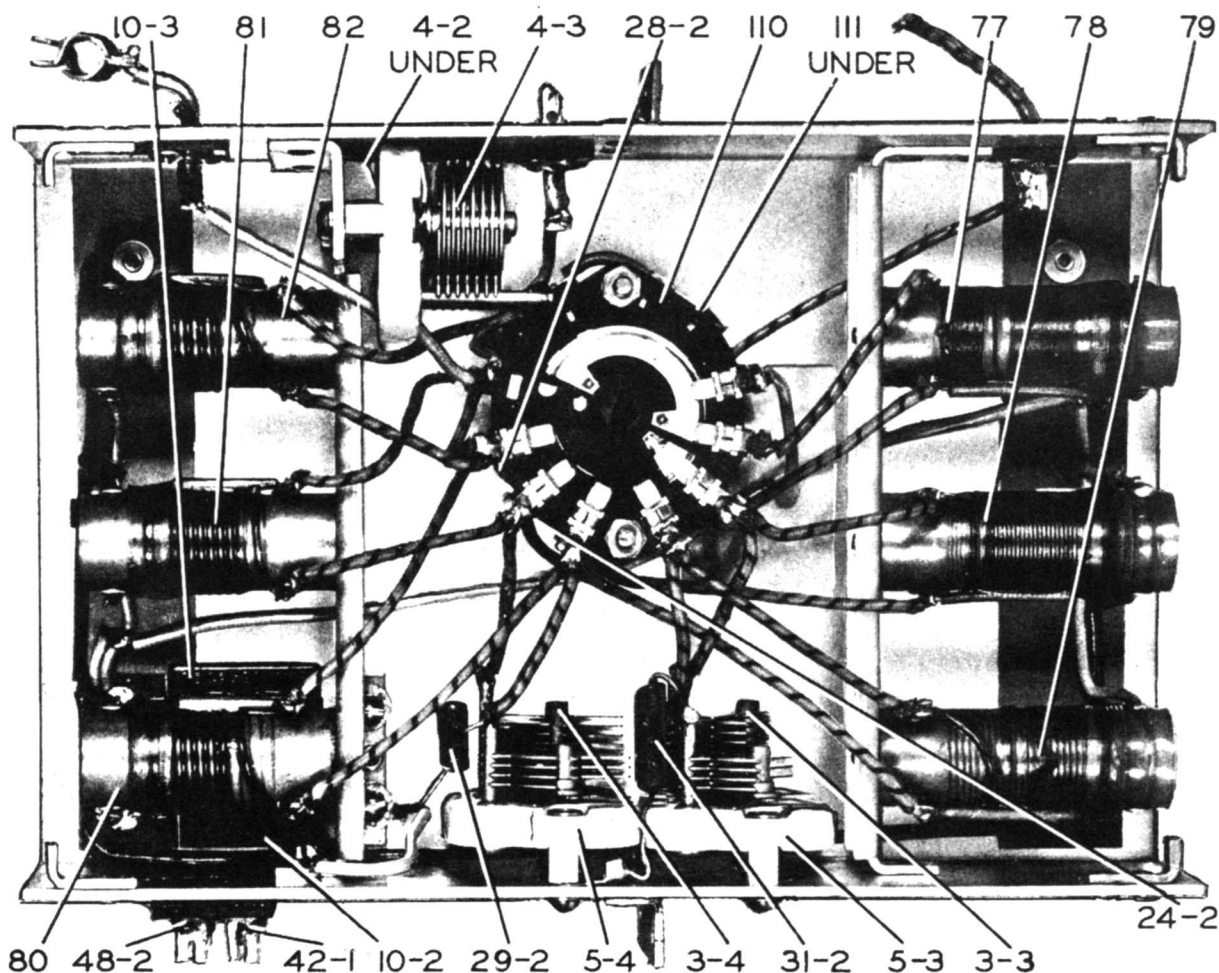

FIGURE 27—R-F UNIT

be determined. The bandwidth can be adjusted by changing the capacity setting of the balancing condenser 7. For each setting of this condenser the bandwidth at 10 times input should be checked as described above. In general the minimum bandwidth is obtained with the balancing condenser at approximately mid-capacity (adjustment slot perpendicular to front panel) with the bandwidth increasing for con-

not heard on any band, the heterodyne oscillator should be checked for oscillation. This can be done by observing the cathode voltages at the socket of the first detector Tube VT-91, when grounding the stator of the oscillator section (1-D) of the tuning capacitor. If no change in voltage is noted with this test, the oscillator circuit should be checked for grounds, shorts or defective components.

(12) *Test of the R-F Amplifier*

Having completed the test and alignment of the audio amplifier, i-f amplifier and heterodyne oscillator, the r-f amplifier is tested as follows:

With the band switch set on the band lacking sensitivity, a modulated signal from the test oscillator is capacitively coupled through a 100 mmf dummy antenna to the antenna post and to

tubes should show a progressive decrease in output indicating the proper functioning of the particular r-f stage or circuits preceding. If a decrease in response is noted when the signal input is capacitively coupled progressively from the grid of the first detector to the second and first r-f grid caps and finally to the antenna post (with the 100 mmf dummy antenna capacitor),

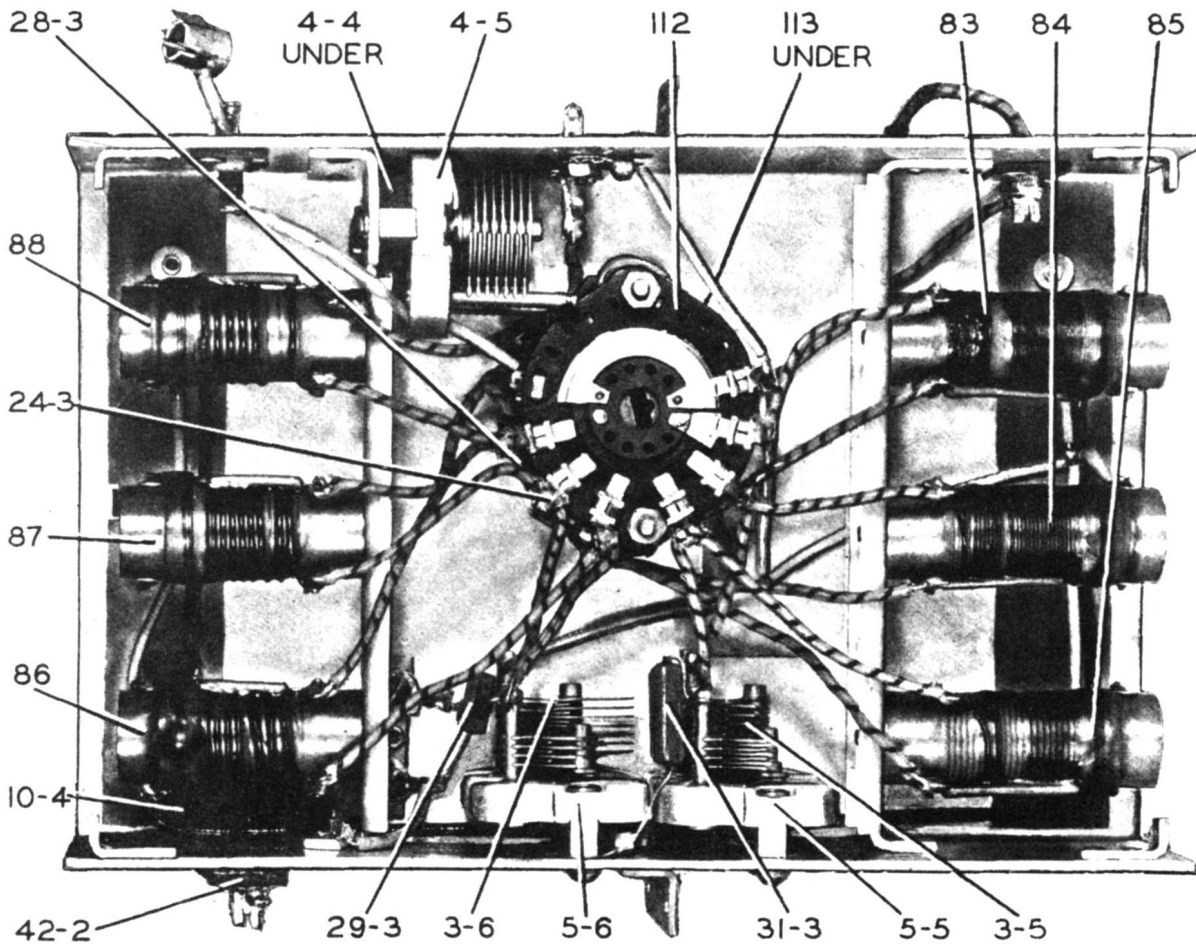

FIGURE 28—DETECTOR UNIT

ground. This input signal frequency should be set quite accurately to the alignment frequency shown in the "Table of Alignment Data" for the band under test. With the tuning control set for the approximate alignment frequency, tune slowly around this point until the maximum response with the least signal input is obtained. Capacitively coupling the test oscillator to the grid of the first r-f and second r-f

the stage which indicates a decrease in response should be checked for circuit, ground, shorts or defective components.

(13) *Alignment of R-F Amplifier*

NOTE: For a general alignment start with the 1.5-3.0 MC Band No. 1.

In the r-f alignment for any particular band the tuning control is adjusted for

the alignment frequency (Table of Alignment Data) and the modulated test signal at this alignment frequency is coupled from the test oscillator to the antenna post through the 100 mmf dummy antenna. The three r-f trimmers (Ant.; RF.; and Det.) for this band, are then adjusted for maximum output. A similar procedure is followed in the alignment of each band.

(14) *Alignment of Heterodyne Oscillator*

NOTE: For a general alignment start with the 1.5-3.0 MC Band No. 1.

The alignment of the Heterodyne Oscillator is necessary only when the tuning dial frequency calibration is in error by more than 0.5 per cent. To align the oscillator follow the same general procedure as was followed for the alignment of the r-f amplifier. With the Band Switch on Band No. 1 (1.5-3.0

e *Weak or No Signals on All Bands, C-W Reception (Modulated Reception Normal)*

Weak or no signals on all bands for c-w reception with satisfactory modulated signal reception requires testing and alignment of the c-w oscillator. Proceed as outlined in paragraphs 35c (8) and 35c (9).

f *Measurements with Test Set I-56-A*

GENERAL—The following readings are typical values obtained on the Weston Model 665-2 Selective Analyzer (Test Set I-56-A). If all plugs seem to be securely in position with the dynamotor running and faulty or poor operation is obtained from the receiver, a careful check should first be made of the cables and plugs using the Model 564 Volt-ohmmeter as outlined under "Detailed Tests on Radio Sets", page 11 of the Instruction Book for Test Set I-56-A. If all plug-in cable connections seem to be functioning properly, a test should be made of the tubes

Table of Alignment Data

Band No.	Freq. Range MC	Alignment Frequency MC	Trimmers*			
			Ant.	RF	I Det.	Osc.
1	1.5- 3.0	3.0	2**	4-3	4-5	6-1
2	3.0- 5.0	5.0	3-1	3-3	3-5	6-2
3	5.0- 7.5	7.5	5-1	5-3	5-5	6-3
4	7.5-10.5	10.5	5-2	5-4	5-6	6-4
5	10.5-14.0	14.0	3-2	3-4	3-6	3-7
6	14.0-18.0	18.0	4-1	4-2	4-4	3-8

\*Refer to Schematic Diagram and marked photographs for location. The alignment controls for the various bands are numbered on the chassis adjacent to the control. Controls for band 1 are marked 1, those for 2 are marked 2, etc.

\*\*Antenna alignment control.

mc) and the Tuning Control set to the alignment frequency, couple the output of the modulated test oscillator (set at the alignment frequency) to the antenna post through the 100 mmf dummy antenna. The oscillator trimmer for this band is adjusted for maximum audio output. A similar procedure is followed in the alignment of each band.

d *Weak or No Signals on Any One Band, Modulated Reception*

The condition of satisfactory reception on several bands and weak or no signals on one or more bands, indicates the correct functioning of the i-f and a-f amplifiers and requires checking only the r-f amplifier and heterodyne oscillator for the defective band or bands. The procedure outlined in paragraphs 35c (11) to 35c (14) should be followed for the defective band or bands.

in the receiver using the Model 685 tube tester as outlined in the same paragraphs as mentioned above. Should neither of these tests locate the difficulty, voltage and current or resistance measurements should be made as outlined in the following paragraphs:

(1) *Voltage and Current Measurements*

Set up the receiver and a Model 665 Analyzer for operation as outlined under general voltage and current measurements. To obtain the various readings, connect the jumper leads from the socket selector block to the analyzer pin jacks in accord with the instructions given below.

*Procedure*

1. Release the thumb screws and pull the complete chassis out of the case.

Par. 35

2. Power connections should be made to the plug socket at the rear of the receiver chassis.
3. Be sure the plug and tube top grid connections are secure when taking readings.
4. Keep the analyzer "AC-DC" switch on "DC".
5. Place the analyzer left-hand toggle
8. Set the receiver control switch on the "MVC" position unless otherwise specified.
9. Set the receiver with the volume control at the maximum position (extreme clockwise).
10. Set the tuning control to 1.5 mc (L-F end of Band 1); readings should deviate but slightly when

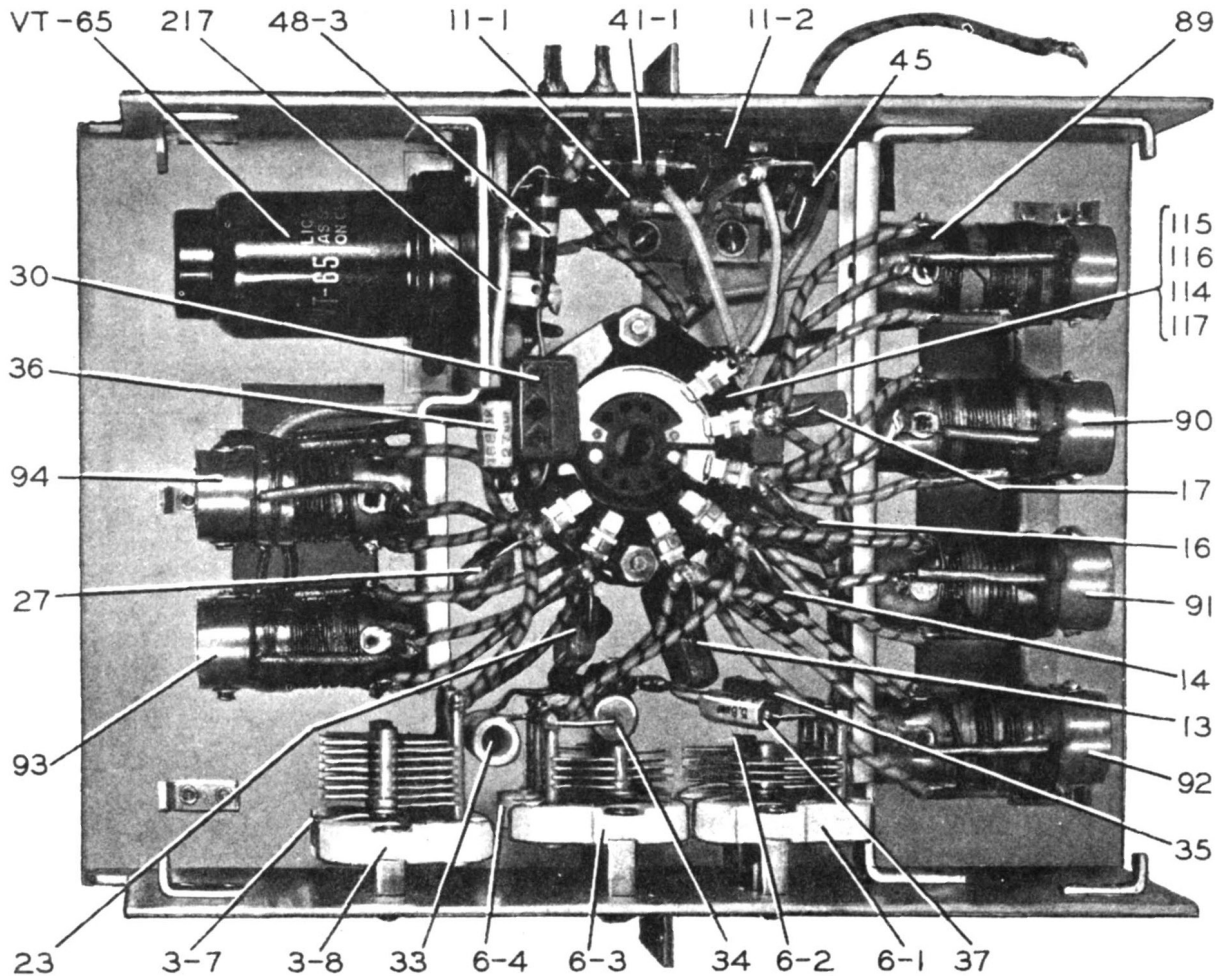

FIGURE 29—OSCILLATOR UNIT

- switch in the "VOLTS-MA" position.
6. Connect the short jumper cables for the various tests as indicated in table below.
  7. Connect jumper cable from black terminal "GND" to receiver chassis.

- switching to other bands with the tuning control remaining at the low frequency end of each band.
11. The c-w oscillator should be "OFF" for the readings in Table A and "ON" for the readings in Table B.

Test	Tube	Function	Block Terminal Number	to	Analyzer Jacks
Plate Voltage	VT-86	RF & IF Ampl.	3	gnd	250 V ± V
	VT-91	1st Det.			
	VT-93	3rd IF			
	VT-65	RF Osc.			
Screen Voltage	VT-48	Audio	2	gnd	250 V ± V
	VT-70	2nd IF			
	VT-86	RF & IF Ampl.			
	VT-91	1st Det.			
Cathode Voltage	VT-48	Output	3	gnd	250 V ± V 250 V ± V
	VT-70	2nd IF, Cw-Osc.			
	VT-93	3rd IF			
	VT-86	RF & IF Ampl.			
Heater Voltage	VT-91	1st Det.	8	gnd	10 V ± V 10 V ± V
	VT-65	RF Osc.			
	VT-70	2nd IF, Cw-Osc.			
	VT-93	3rd IF, 2nd Det.			
Triode Voltage	VT-48	Output	5	gnd	25 V ± V
	VT-65	RF Osc.			
	VT-86	1st RF, 2nd RF			
	VT-91	1st Det.			
Diode Voltage	VT-93	3rd IF	7	2	10 V ± V
	VT-86	1st IF			
	VT-70	2nd IF			
	VT-48	Output			
Plate Current	VT-86	RF & IF Ampl.	3	Outside	10 ma.
	VT-91	1st Det.			
	VT-65	RF Osc.			
	VT-93	3rd IF, 2nd Det.			
Screen Current	VT-48	Output	2	Outside	25 ma.
	VT-70	2nd IF CW-Osc.			
	VT-86	RF & IF Ampl.			
	VT-91	1st Det.			
Triode Voltage	VT-48	Output	2	Inside	— ma.
	VT-70	2nd IF CW-Osc.			
	VT-86	RF & IF Ampl.			
	VT-91	1st Det.			
Diode Voltage	VT-48	Output	3	Outside	5 ma.
	VT-70	2nd IF CW-Osc.			
	VT-86	RF & IF Ampl.			
	VT-91	1st Det.			
Plate Current	VT-48	Output	3	Inside	— ma.
	VT-70	2nd IF CW-Osc.			
	VT-86	RF & IF Ampl.			
	VT-91	1st Det.			
Screen Current	VT-48	Output	6	Outside	1 ma.
	VT-70	2nd IF CW-Osc.			
	VT-86	RF & IF Ampl.			
	VT-91	1st Det.			
Triode Voltage	VT-48	Output	6	Inside	— ma.
	VT-70	2nd IF CW-Osc.			
	VT-86	RF & IF Ampl.			
	VT-91	1st Det.			

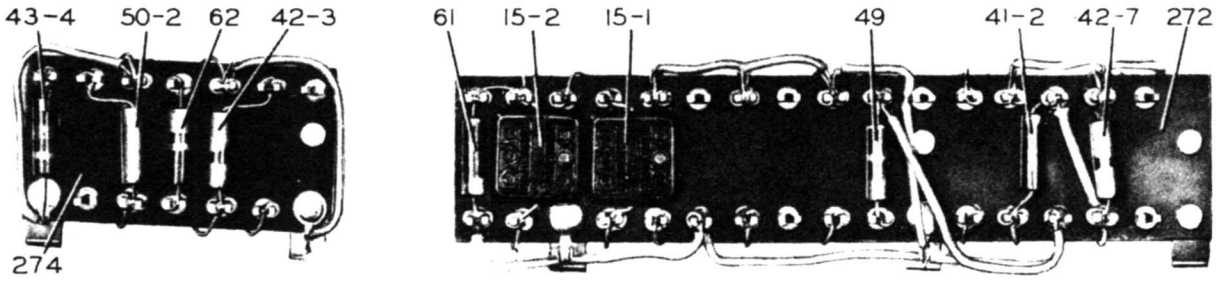
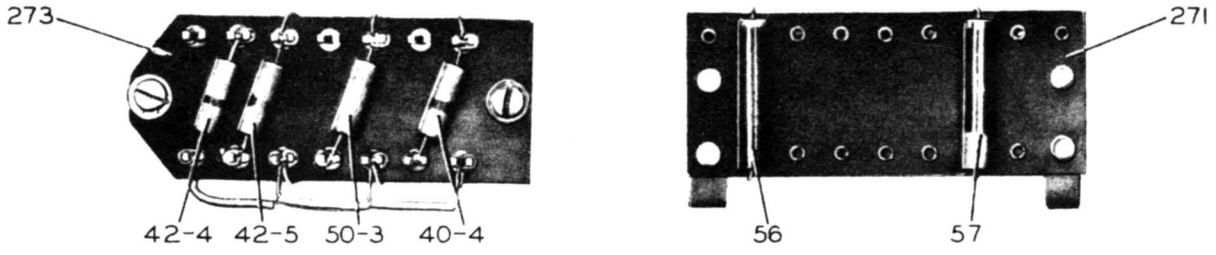

FIGURE 30—RADIO RECEIVER BC-224-B: RESISTOR BOARDS, VIEW A

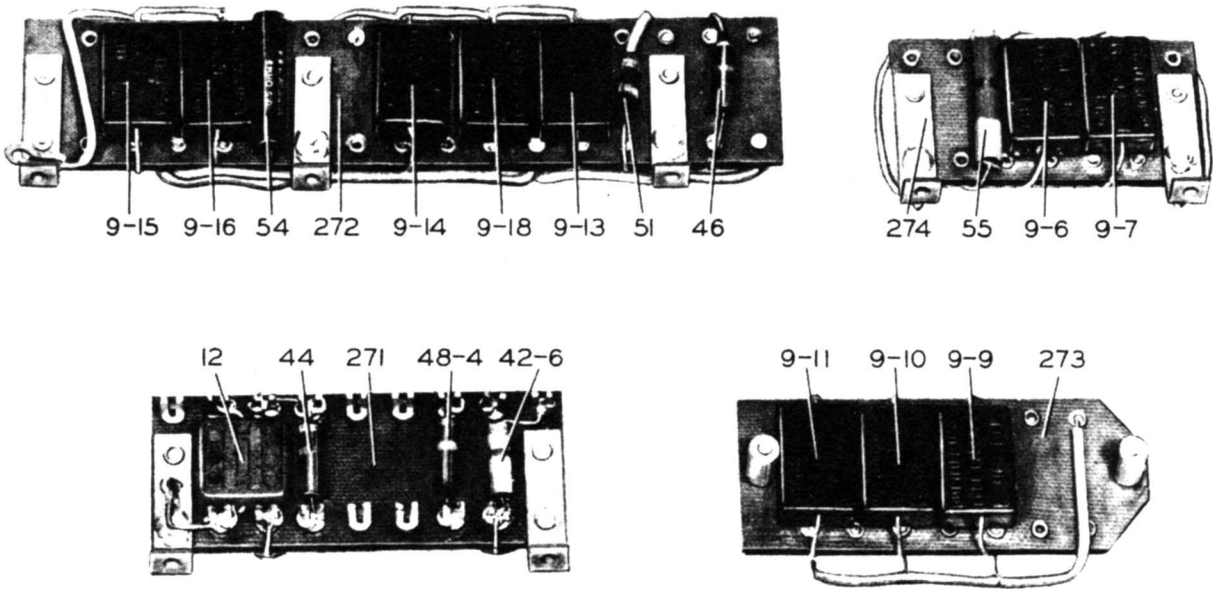

FIGURE 31—RADIO RECEIVER BC-224-B: RESISTOR BOARDS, VIEW B

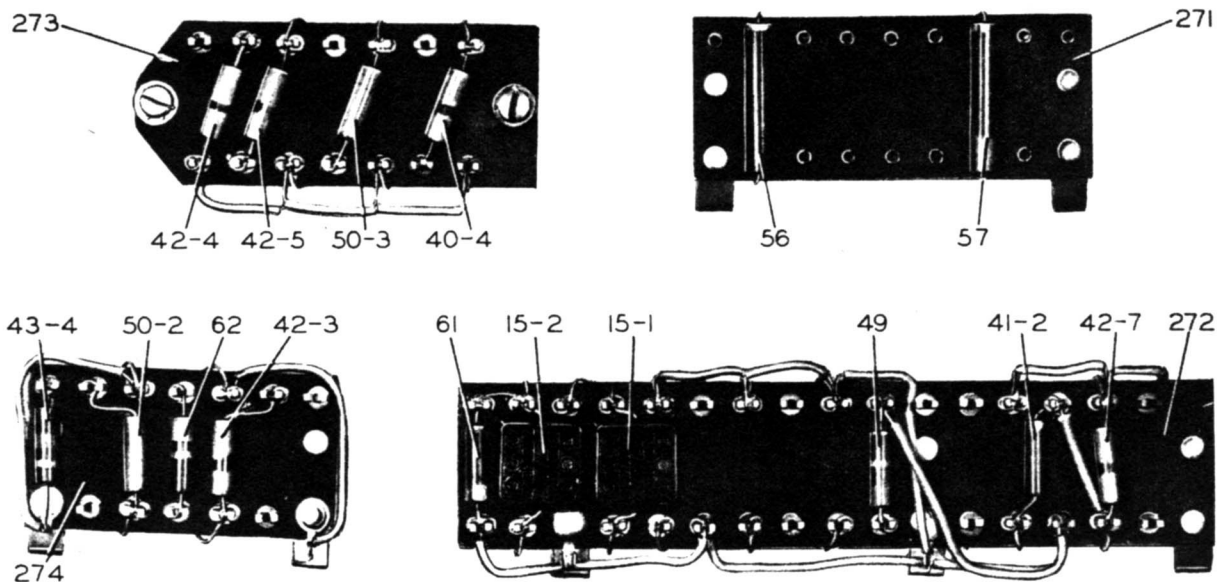

FIGURE 32—RADIO RECEIVER BC-348-B: RESISTOR BOARDS, VIEW A

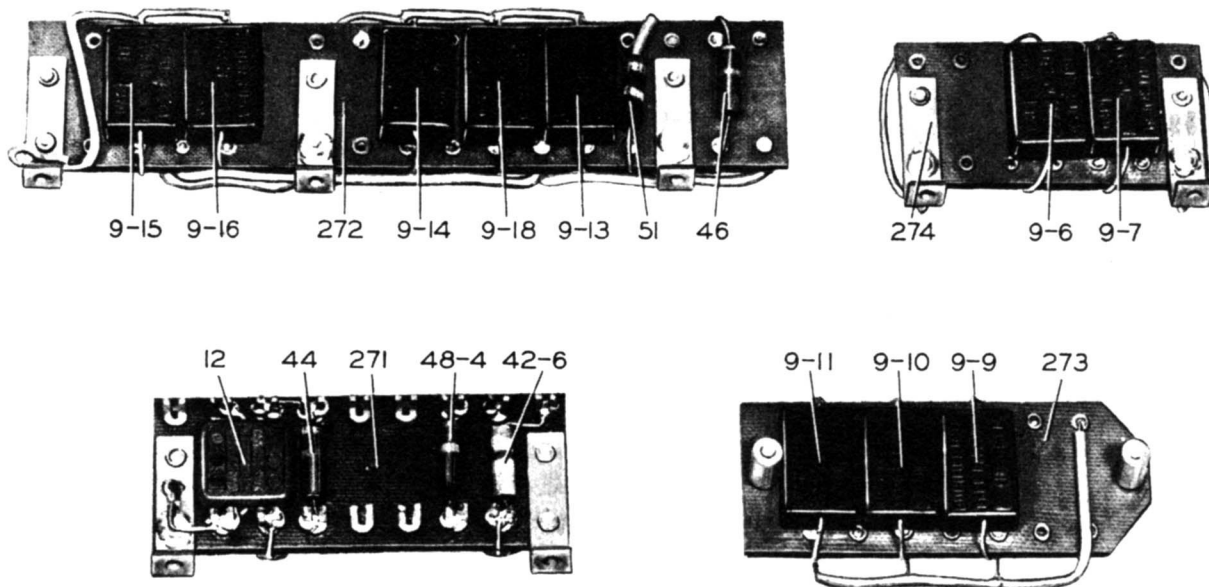

FIGURE 33—RADIO RECEIVER BC-348-B: RESISTOR BOARDS, VIEW B



NOTE: The readings given below are average values taken on receivers of this type using a 14-volt power supply (or 28-volt power supply depending on receiver used). Meter indications within  $\pm 10\%$  of these values will in most cases indicate correct operation.

TABLE A. C-W. Osc. "OFF"

Stage	Tube	Plate Volts	Screen Volts	Cathode Volts	Heater Volts	M.A. Plate Current	M.A. Screen Current
1 RF.	VT-86	184	70	2.6	6.3	4.1	1.0
2 RF.	VT-86	177	86	3.2	6.3	4.8	1.3
1 Det.	VT-91	202	96	4.2	6.3	0.23	0.08
Osc.	VT-65	58	..	0.0	6.3	1.6	....
1 IF	VT-86	182	82	3.1	6.5	4.7	1.2
2 IF	VT-70	207	82	3.1	6.5	4.5	1.4
3 IF	VT-93	207	72	21.0	6.5	2.5	0.6
Output	VT-48	197	207	0.0	6.5	18.0	3.2
2 Det.	VT-93 Diode	8.0					

TABLE B. C-W. Osc. "ON"

Stage	Tube	Plate Volts	Screen Volts	Cathode Volts	Heater Volts	M.A. Plate Current	M.A. Screen Current
1 RF.	VT-86	197	37	1.3	6.3	2.0	0.55
2 RF.	VT-86	188	65	2.3	6.3	3.7	1.0
1 Det.	VT-91	204	72	3.4	6.3	0.17	0.06
Osc.	VT-65	58	..	0.0	6.3	1.6	...
1 IF	VT-86	195	44	1.6	6.5	2.3	0.5
2 IF	VT-70	210	44	1.6	6.5	2.2	0.5
3 IF	VT-93	210	72	21.0	6.5	2.5	0.6
Output	VT-48	198	210	0.0	6.5	23.5	3.6
CW Osc.	VT-70 Triode	18.0					

## (2) Resistance and Continuity Measurements

Remove the chassis from the cabinet and do not make any connections to the plug socket at the rear of the chassis. This procedure permits the operation of all switches without running the dynamotor and causing voltages to be built up across the various resistors and condensers. Any voltages set up by the dynamotor in the receiver would cause serious errors in reading on the ohmmeter ranges or might possibly damage the test instruments.

### Procedure

1. Set the receiver control switch to "MVC" unless otherwise specified.
2. Set the receiver with the volume control at the maximum position (extreme clockwise).
3. Set the tuning control to 1.5 mc (L-F end of Band 1); readings should not deviate when switching to other bands with the tun-

ing control remaining at the low-frequency end of each band.

4. The c-w oscillator should be "OFF" for the readings in Table C and "ON" for the readings in Table D.
5. Shift the analyzer left-hand toggle switch to the ohms position.

Set up the Model 665 Analyzer for resistance and continuity measurements as outlined under "General Resistance and Continuity Tests" in the Test Set instruction book. Before taking a resistance reading on any range, short the two jumper leads plugged into the ohmmeter pin jacks and rotate the "battery adjustment" knob until the instrument pointer reads exactly full scale. Should it be found impossible to bring the pointer up to the top mark refer to the paragraphs on battery replacement under the heading "Maintenance" in the Test Set instruction book. Plug the pin tip end of the 3 foot clip lead into the block hole marked "GND" and clip the

other end to the chassis. Connect one of the jumper leads between the remaining ground jack and one of the ohmmeter jacks on the required range. Connect the other jumper lead from the remaining ohmmeter range jack to the tube element under test. In general, ohmmeter readings will be most accurate when taken on the upper 2/3 of the

scale and wherever possible, the range should be chosen that will give indications in this area.

*g Failure of Dial Lights*

The two dial lamps are connected in series hence the failure of either lamp does not indicate failure of both lamps. Removal of the dial light housing gives ready access to the lamps.

NOTE: The readings tabulated below are average values taken on receivers of this type with the storage battery disconnected. Meter indications within plus or minus 10% of these values will in most cases indicate correct operation.

**Resistance to Ground (Ohms)**

**TABLE C. "C-W. OSC. "OFF"**

Stage	Tube	Cathode	Plate	Screen	"MVC" Grid	"AVC" Grid
1 RF.	VT-86	490	5,200	80,000	100,000	1.8 meg.
2 RF.	VT-86	480	5,200	75,000	100,000	1.8 meg.
1 Det.	VT-91	15,000	5,600	75,000	0	0
Osc.	VT-65	0	41,000	.....	100,000	100,000
1 IF.	VT-86	520	5,600	70,000	500,000	1.8 meg.
2 IF.	VT-70	470	500	70,000	500,000	2.25 meg.
3 IF.	VT-93	6,200	500	180,000	5,000	5,000
Output	VT-48	0	1,080	480	700,000	

**TABLE D. "C-W OSC" "ON"**

Stage	Tube	Cathode	Plate	Screen	"MVC" Grid	"AVC" Grid
1 RF.	VT-86	490	5,200	20,000	100,000	1.8 meg.
2 RF.	VT-86	480	5,200	23,000	100,000	1.8 meg.
1 Det.	VT-91	15,000	5,600	23,000	0	0
Osc.	VT-65	0	41,000	.....	100,000	100,000
1 IF.	VT-86	520	5,600	9,200	500,000	1.8 meg.
2 IF.	VT-70	470	500	9,200	500,000	2.25 meg.
3 IF.	VT-93	6,200	500	180,000	5,000	5,000
Output	VT-48	0	1,080	480	700,000	....
C-W Osc.	VT-70	...	82,000	.....	500,000	....
Det. Diode	VT-93	...	180,000	.....	.....	....
AVC Diode	VT-93	...	380,000	.....	.....	....

## SECTION V

### Supplementary Data and List of Replaceable Parts

NOTE: In the List of Replaceable Parts, those parts having identical part numbers followed by letters are constructed as common assemblies. In the Table of Replaceable Parts I, all parts listed are common to both the BC-224-B and the BC-348-B except those parts whose reference number is followed by an asterisk which indicates those parts are used only in the BC-

224-B. All parts listed in the Table of Replaceable Parts II are used only in the BC-348-B.

The following symbols are used in columns 4 and 6 of the List of Replaceable Parts to indicate the part manufacturer. Where no manufacturer is indicated, the part is manufactured by RCA Manufacturing Company, Inc.

Manufacturer	Symbol
Radio Condenser Co. ....	RC
Hammerlund Manufacturing Co. ....	HM
Micromold Radio Corp. ....	MR
Cornell-Dubilier Corp. ....	CD
Aerovox Corp. ....	A
Erie Resistor Corp. ....	ER
Central Radio Laboratory ....	CRL
International Resistance Co. ....	IRC
P. R. Mallory Co. ....	PRM
Allen-Bradley Co. ....	AB
A. D. Cardwell Co. ....	ADC

Manufacturer	Symbol
General Electric Co. ....	GE
Arrow-Hart & Hegeman Co. ....	AHH
Oak Manufacturing Co. ....	OM
Littelfuse Laboratories ....	LL
Lovejoy Chaplet Co. ....	LC
National Lock Co. ....	NL
Aluminum Goods Manufacturing Co. ..	AG
Cinch Manufacturing Co. ....	CM
H. Cole & F. C. Hersee Co. ....	CH
Eicor, Inc. ....	E
S. S. White Dental Co. ....	SW

TABLE OF REPLACEABLE PARTS I

Reference No.	Stock No.	Name of Part	Description	Function	Drawing No.
1-A		Capacitor	A Section, 16 to 233 mmfd ±1% Special	Main Tuning	RC P-720214-501
1-B	B Section, 16 to 233 mmfd ±1% Special				
1-C	C Section, 16 to 233 mmfd ±1% Special				
1-D	D Section, 16 to 233 mmfd ±1% Special				
2		Capacitor	Air Trimmer, 50 mmfd Max Type APC Special	Antenna Coupling	HM M-420224-14
3-1		Capacitor	Air Trimmer, 50 mmfd Max Type APC	Antenna Unit Trim- mer	HM M-420224-3
3-2				Antenna Unit Trim- mer	
3-3				R-F Unit Trimmer	
3-4				R-F Unit Trimmer	
3-5				1st Det. Unit Trimmer	
3-6				1st Det. Unit Trimmer	
3-7				Osc. Unit Trimmer	
3-8				Osc. Unit Trimmer	
4-1		Capacitor	Air Trimmer, 50 mmfd Max Type APC	Antenna Unit Trim- mer	HM M-420224-10
4-2				R-F Unit Trimmer	
4-3				R-F Unit Trimmer	
4-4				1st Det. Unit Trimmer	
4-5				1st Det. Unit Trimmer	
5-1		Capacitor	Air Trimmer, 25 mmfd Max Type APC	Antenna Unit Trim- mer	HM M-420224-11
5-2				Antenna Unit Trim- mer	
5-3				R-F Unit Trimmer	
5-4				R-F Unit Trimmer	
5-5				R-F Unit Trimmer	

Reference No.	Stock No.	Name of Part	Description	Function	Drawing No.
5-6		Capacitor	Air Trimmer, 25 mmfd Max Type APC	1st Det. Trimmer 1st Det. Trimmer	HM M-420224-15
6-1 } 6-2 } 6-3 } 6-4 }		Capacitor	Air Trimmer, 25 mmfd Max Type APC	Osc. Unit Trimmer Osc. Unit Trimmer Osc. Unit Trimmer Osc. Unit Trimmer	HM M-420224-15
7		Capacitor	Air Trimmer, 10 mmfd Max Type APC	Crystal Filter Ad- justment	HM M-420224-13
8		Capacitor	Air Trimmer, 10 mmfd Max Type APC Special	Beat Osc. Freq. Ad- justment	HM M-420224-12
9-1 } 9-2 } 9-3 } 9-4 } 9-5 } 9-6 } 9-7 } 9-8 } 9-9 } 9-10 } 9-11 } 9-12 } 9-13 } 9-14 }		Capacitor	Mica, 500V DC, 0.01 mfd $\pm 10\%$ with Leads, CD Type 3W, or MR Special	1st R-F Cathode By-pass 1st R-F Screen By-pass 2nd R-F Cathode By-pass 2nd R-F Screen By-pass 1st Det. Screen By-pass 1st I-F Trans- former By-pass Crystal Filter Trans- former By-pass 1st I-F Cathode By-pass 1st I-F Plate By-pass 2nd I-F Transformer By-pass 2nd I-F Cathode By-pass C-W Osc. Plate By- pass Plug Termin- al By-pass	CD or MR M-420394-1

Reference No.	Stock No.	Name of Part	Description	Function	Drawing No.
9-15		Capacitor	Mica, 500V DC, 0.01 mfd $\pm 10\%$ with Leads, CD Type 3W, or MR Special	{ AVC By- pass 3rd I-F Trans- former By-pass }	CD or MR M-420394-1
9-16	}		Mica, 500V DC, 0.01 mfd $\pm 10\%$ with Leads, CD Type 3W, or MR Special	{ 3rd I-F Cathode By-pass Heater By-pass Battery By-pass }	
9-17					
9-18					
10-1	}	Capacitor	Mica, 500V DC, 0.01 mfd $\pm 10\%$ with Lugs, CD Type 3L, or MR Special	{ Antenna Coil By- pass R-F Plate By-pass R-F Coil By-pass 2nd R-F Plate By-pass }	CD or MR M-420394-3
10-2					
10-3					
10-4					
11-1					
11-2	}			{ Heterodyne Osc. Plate By-pass 1st Det. Cathode By-pass }	CD or MR M-420394-23
12					
12			Mica, 500V DC, .005 mfd $\pm 10\%$ with Leads, CD Type 1R, or A Type 1464	Audio Trans- former Secondary By-pass	CD or A M-420394-24
13			Mica, 500V DC, .003 mfd $\pm 5\%$ with Leads, CD Type 1R, or A Type 1464	Osc. Series	CD or A M-420394-13
14			Mica, 500V DC, .002 mfd $\pm 5\%$ with Leads, CD Type 1R, or A Type 1464	Osc. Series	CD or A M-420394-12
15-1	}	Capacitor	Mica, 500V DC, .0015 mfd $\pm 10\%$ with Leads, CD Type 1W, or A Type 1467	{ Audio Coupling Condenser Audio Trans- former Pri- mary By-pass }	CD or A M-420394-6
15-2					

Reference No.	Stock No.	Name of Part	Description	Function	Drawing No.
16		Capacitor	Mica, 500V DC, .00125 mfd $\pm 3\%$ with Leads, CD Type 1R, or A Type 1464	Osc. Series	CD or A M-420394-14
17		Capacitor	Mica, 500V DC, 520 mmfd $\pm 1.5\%$ with Leads, CD Type 2R, or ER Type K	Osc. Series	CD or ER M-420394-20
18-1 } 18-2 }		Capacitor	Mica, 500V DC, 500 mmfd $\pm 5\%$ with Leads, CD Type 5R, or ER Type K	1st I-F Trans- former Secondary Tuning 1st I-F Trans- former Secondary Tuning	CD or ER M-420394-25
19			Mica, 500V DC, 285 mmfd $\pm 5\%$ with Leads, CD Type 5R, or ER Type K	Crystal Trans- former Tuning	CD or ER M-420394-4
20-1 } 20-2 } 20-3 }		Capacitor	Mica, 500V DC, 260 mmfd $\pm 5\%$ with Leads, CD Type 5R, or ER Type K	2nd I-F Trans- former Primary Tuning 2nd I-F Trans- former Secondary Tuning 3rd I-F Trans- former Secondary Tuning	CD or ER M-420394-19
21-1 } 21-2 }		Capacitor	Mica, 500V DC, 250 mmfd $\pm 5\%$ with Leads, CD Type 5R, or ER Type K	1st I-F Trans- former Primary Tuning 3rd I-F Trans- former Primary Tuning	CD or ER M-420394-18

Reference No.	Stock No.	Name of Part	Description	Function	Drawing No.
22-1 } 22-2 }		Capacitor	Mica, 500V DC, 240 mmfd $\pm 5\%$ with Leads, CD Type 5R, or ER Type K	C-W Osc. Padding 2nd Det. By-pass	CD or ER M-420394-17
23		Capacitor	Mica, 500V DC, 176 mmfd $\pm 1.2\%$ with Leads, CD Type 5R, or ER Type K	Osc. Series	CD or ER M-420394-16
24-1 } 24-2 } 24-3 }		Capacitor	Mica, 500V DC, 155 mmfd $\pm 1.8\%$ with Leads, CD Type 5R, or ER Type K	Antenna Series R-F Series 1st Det. Series	CD or ER M-420394-8
...					
26-1 } 26-2 }		Capacitor	Mica, 500V DC, 150 mmfd $\pm 5\%$ with Leads, CD Type 5R, or ER Type K	C-W Osc. Grid 4th I-F Trans- former Sec- ondary Tuning	CD or ER M-420394-21
27		Capacitor	Mica, 500V DC, 145 mmfd $\pm 1.2\%$ with Leads, CD Type 5R, or ER Type K	Heterodyne Osc. Series	CD or ER M-420394-15
28-1 } 28-2 } 28-3 }		Capacitor	Mica, 500V DC, 135 mmfd $\pm 2\%$ with Leads, CD Type 5R, or ER Type K	Antenna Unit Series R-F Unit Series 1st Det. Unit Series	CD or ER M-420394-7
29-1 } 29-2 } 29-3 }		Capacitor	Mica, 500V DC, 130 mmfd $\pm 5\%$ with Leads, CD Type 5R, or ER Type K	Antenna Unit Pad- ding R-F Unit Padding 1st Det. Unit Padding	CD or ER M-420394-10
30		Capacitor	Mica, 500V DC, 100 mmfd $\pm 5\%$ with Leads, CD Type 5R, or ER Type K	Heterodyne Osc. Grid	CD or ER M-420394-11



Reference No.	Stock No.	Name of Part	Description	Function	Drawing No.
31-1 31-2 31-3 31-4		Capacitor	Mica, 500V DC, 75 mmfd $\pm 5\%$ with Leads, CD Type 5R, or ER Type K	Antenna Padding R-F Padding 1st Det. Padding Diode Coupling	CD or ER M-420394-9
32		Capacitor	Mica, 500V DC, 47 mmfd $\pm 5\%$ with Leads, CD Type 5R, or ER Type K	4th I-F Trans- former Primary Tuning	CD or ER M-420394-22
33		Capacitor	Ceramic, 500V 130 mmfd $\pm 2.5\%$ with Leads, ER Type N100D	Osc. Tem- perature Compensat- ing	ER M-420506-4
34		Capacitor	Ceramic, 500V 85 mmfd $\pm 2.5\%$ with Leads, ER Type NP0M	Osc. Tem- perature Compensat- ing	ER M-420506-3
35		Capacitor	Ceramic, 500V 47 mmfd $\pm 5\%$ with Leads, CRL Type 813ZTC	Osc. Tem- perature Compensat- ing	CRL M-420506-2
36		Capacitor	Ceramic, 500V 27 mmfd $\pm 2.5\%$ with Leads, ER Type N680K	Osc. Tem- perature Compensat- ing	ER M-420506-5
37		Capacitor	Ceramic, 500V 5.6 mmfd $\pm 5\%$ with Leads, ER Type N680L	Osc. Tem- perature Compensat- ing	ER M-420506-1
38-1A 38-1B 38-2A 38-2B 38-3A		Capacitor	Oil, 250V DC, 0.5 mfd $\pm 15$	4th I-F Trans- former Filter Volume Control Filter Screen Volt- age Filter Output Plate Filter Noise Com- pensator Filter	M-420505-1

Reference No.	Stock No.	Name of Part	Description	Function	Drawing No.
38-3B		Capacitor	Oil, 250V DC, 0.5 mfd $\pm 15\%$	1st I-F Screen Filter	M-420505-1
39-1A				4th I-F Trans- former Filter	M-420505-2
39-1B				4th I-F Trans- former Filter	
39-2A				Output Grid Filter	
39-2B		Capacitor	Oil, 250V DC, 0.5 mfd $\pm 15\%$	Screen Volt- age Filter	M-420505-2
39-3A				1st I-F Screen Filter	
39-3B				3rd I-F Screen Filter	
40-1	3Z6047	Resistor	Insul. 470 ohms $\pm 10\%$ , $\frac{1}{2}$ W, Type BT- $\frac{1}{2}$	1st R-F Cathode	IRC K-850981-58
40-2				2nd R-F Cathode	
40-3				1st I-F Cathode	
40-4				2nd I-F Cathode	
41-1	3Z4525	Resistor	Insul. 1,000 ohms $\pm 10\%$ , $\frac{1}{2}$ W, Type BT- $\frac{1}{2}$	Osc. Plate	IRC K-850981-62
41-2				3rd I-F Cathode	
42-1	3Z6470	Resistor	Insul. 4,700 ohms $\pm 10\%$ , $\frac{1}{2}$ W, Type BT- $\frac{1}{2}$	1st R-F Plate	IRC K-850981-70
42-2				2nd R-F Plate	
42-3				1st Det. Plate	
42-4				1st I-F Screen	
42-5				1st I-F Plate	
42-6				Bleeder	
42-7				3rd I-F Cathode	
43-1	3Z4529	Resistor	Insul. 10,000 ohms $\pm 10\%$ , $\frac{1}{2}$ W, Type BT- $\frac{1}{2}$	1st R-F Screen	IRC K-850981-74
43-2				2nd R-F Screen	
43-3				1st Det. Screen	
43-4				CW Osc. Bleeder	
44	3Z6612-1	Resistor	Insul. 12,000 ohms $\pm 10\%$ , $\frac{1}{2}$ W, Type BT- $\frac{1}{2}$	Voltage Regulator Series	IRC K-850981-75

Reference No.	Stock No.	Name of Part	Description	Function	Drawing No.
45	3Z4614	Resistor	Insul. 15,000 ohms $\pm 10\%$ , $\frac{1}{2}$ W, Type BT- $\frac{1}{2}$	1st Det. Cathode	IRC K-850981-76
46	3Z6656-1	Resistor	Insul. 56,000 ohms $\pm 10\%$ , $\frac{1}{2}$ W, Type BT- $\frac{1}{2}$	Output Loading	IRC K-850981-83
47	3Z6668	Resistor	Insul. 68,000 ohms $\pm 10\%$ , $\frac{1}{2}$ W, Type BT- $\frac{1}{2}$	CW Osc. Plate	IRC K-850981-84
48-1 48-2 48-3 48-4	3Z4550	Resistor	Insul. 100,000 ohms $\pm 10\%$ , $\frac{1}{2}$ W, Type BT- $\frac{1}{2}$	1st R-F Grid 2nd R-F Grid Osc. Grid Output Grid Filter	IRC K-850981-86
49	3Z6718	Resistor	Insul. 180,000 ohms $\pm 10\%$ , $\frac{1}{2}$ W, Type BT- $\frac{1}{2}$	3rd I-F Screen	IRC K-850981-89
50-1 50-2 50-3 50-4	3Z6747	Resistor	Insul. 470,000 ohms $\pm 10\%$ , $\frac{1}{2}$ W, Type BT- $\frac{1}{2}$	Antenna Protective 1st I-F Grid 2nd I-F Grid CW Osc. Grid	IRC K-850981-94
51	3Z6756	Resistor	Insul. 560,000 ohms $\pm 10\%$ , $\frac{1}{2}$ W, Type BT- $\frac{1}{2}$	Output Grid	IRC K-850981-95
52	3Z6801A5	Resistor	Insul. 1.5 megohms $\pm 10\%$ , $\frac{1}{2}$ W, Type BT- $\frac{1}{2}$	AVC Diode	IRC K-850981-100
53	3Z6722	Resistor	Insul. 220,000 ohms $\pm 10\%$ , $\frac{1}{2}$ W, Type BT- $\frac{1}{2}$	AVC Filter	IRC K-850981-90
54*	3Z6750-5	Resistor	Insul. 0.5 ohms $\pm 10\%$ , 1W, Type BW-1	Filament	IRC K-845949-32
55*	3Z6006H2	Resistor	Insul. 68 ohms $\pm 10\%$ , 1W, Type BW-1	Filament Balance	IRC K-845949-26
56	3Z6610-11	Resistor	Insul. 10,000 ohms $\pm 10\%$ , 1W, Type BT-1	Bleeder	IRC K-844314-74

Reference No.	Stock No.	Name of Part	Description	Function	Drawing No.
57	3Z6627-1	Resistor	Insul. 27,000 ohms $\pm 10\%$ , 1W, Type BT-1	Voltage Regulator Series Resistor	IRC K-844314-79
58		Resistor	Variable 3,500 $\pm 10\%$ to 10 ohms 0.1W, Type CS	Noise Compensator	IRC K-854157-1
59-A } 59-B }		Resistor	Vol. Control Front Unit, 20,000 $\pm 10\%$ to 10 ohms, 2W Special Vol. Control Back Unit, 350,000 $\pm 10\%$ to 50 ohms, .2W	MVC AVC	AB M-420382-1
60*		Resistor	Variable, 75 ohms $\pm 10\%$ Special	Dial Lamp Control	PRM K-854364-1
61	3Z6240	Resistor	Insulated, 2,400 ohms $\pm 5\%$ , $\frac{1}{2}$ W, Type BT- $\frac{1}{2}$	Output Plate	IRC K-850981-168
62	3Z6647-1	Resistor	Insulated, 47,000 ohms $\pm 10\%$ , $\frac{1}{2}$ W, Type BT- $\frac{1}{2}$	Bleeder	IRC K-850981-82
63	3Z6006H1	Resistor	Insulated, 68 ohms $\pm 10\%$ , $\frac{1}{2}$ W, Type BT- $\frac{1}{2}$	AVC Compensating	IRC K-850981-48
...					
71			Antenna Band 1	1st R-F Tuned Circuit	P-720231-501
72			Antenna Band 2	1st R-F Tuned Circuit	P-720231-504
73			Antenna Band 3	1st R-F Tuned Circuit	P-720231-507
74		Inductance	Antenna Band 4	1st R-F Tuned Circuit	P-720231-510
75			Antenna Band 5	1st R-F Tuned Circuit	P-720231-513
76			Antenna Band 6	1st R-F Tuned Circuit	P-720231-516

Reference No.	Stock No.	Name of Part	Description	Function	Drawing No.
77		Trans- former	R-F Band 1	1st R-F to 2nd R-F Coupling	P-720231-502
78			R-F Band 2	1st R-F to 2nd R-F Coupling	P-720231-505
79			R-F Band 3	1st R-F to 2nd R-F Coupling	P-720231-508
80			R-F Band 4	1st R-F to 2nd R-F Coupling	P-720231-511
81		Trans- former	R-F Band 5	1st R-F to 2nd R-F Coupling	P-720231-514
82			R-F Band 6	1st R-F to 2nd R-F Coupling	P-720231-517
83		Trans- former	1st Det. Band 1	2nd R-F to 1st Det. Coupling	P-720231-503
84			1st Det. Band 2	2nd R-F to 1st Det. Coupling	P-720231-506
85			1st Det. Band 3	2nd R-F to 1st Det. Coupling	P-720231-509
86			1st Det. Band 4	2nd R-F to 1st Det. Coupling	P-720231-512
87			1st Det. Band 5	2nd R-F to 1st Det. Coupling	P-720231-515
88			1st Det. Band 6	2nd R-F to 1st Det. Coupling	P-720231-518
89		Trans- former	Osc. Band 1	Osc. to 1st. Det. Coupling	P-720230-501
90			Osc. Band 2	Osc. to 1st. Det. Coupling	P-720230-502
91			Osc. Band 3	Osc. to 1st. Det. Coupling	P-720230-503
92			Osc. Band 4	Osc. to 1st. Det. Coupling	P-720230-504
93			Osc. Band 5	Osc. to 1st. Det. Coupling	P-720230-505

Reference No.	Stock No.	Name of Part	Description	Function	Drawing No.
94		Transformer	Osc. Band 6	Osc. to 1st. Det. Coupling	P-720230-506
95			1st I-F	1st Det. to Crystal Coupling	M-420379-503
96			Crystal Filter	Crystal to 1st I-F Coupling	M-420393-501
97		Transformer	2nd I-F	1st I-F to 2nd I-F Coupling	M-420379-504
98			CW Osc.	Grid and Plate Coupling	M-420393-502
99			3rd I-F	2nd I-F to 3rd I-F Coupling	M-420379-501
100			4th I-F	3rd I-F to 2nd Det. Coupling	M-420379-502
101-A		Transformer	Audio	Output	K-900687-501
101-B		Choke	Audio Frequency	Filter	
101-C		Capacitor	Paper, 0.05 mfd $\pm 10\%$ 400V DC	CW Osc. Time Constant	
102-1 } 102-2 }	2Z5534A	Jack	Single Circuit Single Circuit	Headphone Headphone	ADC SC-D-2339-B JK-34-A
103	2V991	Regulator	Neon Bulb, RCA 991	Osc. Plate Volt Regulator	....
104	2Z5927	LM-27	6 to 8 V. GE-44 Mazda	Dial Lamp	GE K-854707-1
105		Switch	SPST Type 1561-KC	Crystal Filter (on-off)	AHH K-854320-1
106		Switch	DPST Type 20902-CZ	CW Osc. (on-off)	AHH M-420278-6
107		Switch	3 Position, 2 Wafers, Type 15824- H2	AVC-OFF- MVC	OM M-420381
108			6 Position, 1 Wafer, Type B-112858	Band Switch Antenna Unit	PRM M-420370-1
109			6 Position, 1 Wafer, Type B-112858	Band Switch Antenna Unit	
110			6 Position, 1 Wafer, Type B-112860	Band Switch R-F Unit	PRM
111			6 Position, 1 Wafer, Type B-112860	Band Switch R-F Unit	M-420372-1

Reference No.	Stock No.	Name of Part	Description	Function	Drawing No.
112			6 Position, 1 Wafer, Type B-112860	Band Switch Det. Unit	PRM M-420372-1
113			6 Position, 1 Wafer, Type B-112860		
114		Switch Assembly	6 Position, 1 Wafer, Type B-112859	Band Switch Osc. Unit	PRM M-420371-1
115			6 Position, 1 Wafer, Type B-112859		
116			6 Position, 1 Wafer, Type B-112859	Band Switch Osc. Unit	
117			6 Position, 1 Wafer, Type B-112859		
118*	2Z1923 -	Fuse FU-23	10 Amp. 25- Volt, Type 1095	Primary Power	LL K-850339-2
119	2C4224A/B13	Binding Post	Panel	Antenna	K-854468-501
120	2C4224A/B12	Binding Post	Panel	Ground	K-854468-502
121		Crystal Assembly	915 KC Crystal in Moulded Case	I-F Filter	K-860749-501
...					
201		Handle	Panel, Modi- fied, Type 0130	Carrying	NL K-854382-1
202		Lever	Control	AVC-OFF- MVC Antenna Alignment Cond., Crystal	K-854387-1
203		Knob	Control	Switch, Dial Lamp Con- trol, and Volume Control	K-854352-1
204		Knob	Control	CW Osc. Freq. Con- trol	K-854352-3
205		Thumb Screws	Dial Window	Holds Dial Window	K-833028-2
206		Knob	Control	Band Change	K-854417-1
207		Knob	Control	Main Tuning Cond.	K-833518-504
208		Cover	Panel	Permits Ac- cess to Tube Shelf	K-854427-1

Reference No.	Stock No.	Name of Part	Description	Function	Drawing No.
209		Special Screw	Shouldered	Main Tuning Capacitor	K-837861-1
210		Special Screw	Shouldered Flathead	Dynamotor Assembly to Mounting Plate	K-850612-3
211		Special Screw	Captive	Dynamotor Assembly	K-850626-1
212		Special Screw	Slotted Hex Head	Dial Assembly to Chassis	K-854496-1
213		Special Screw	Shouldered	Secures Plug to Mounting Plate	K-833571-1
214		Cover	Plate with Captive Screw	Covers Tube in Osc. Unit	K-854451-501
215		Shield	Tube, Special	Shield for Tube VT-70	AG K-854420-1
216*		Fuse Clip Assembly	Laminated Phenolic Strip with Fuse Clips	Power Fuse	K-854457-501
217		Socket	Tube, Octal, Type 6744-WL	For Tubes VT-91, VT-86, VT-93, VT-65	CM K-82747-15
218		Socket	Bayonet Type, Special	For Voltage Regulator	CH K-837884-2
219		Socket	Tube, 6 Prong, Type Z-13WI	For Tube VT-48	CM K-854466-1
220		Socket	Tube, 7 Prong, Type U-13WI	For Tube VT-70	CM K-854466-2
221	2C4224A/S9	Socket	Lamp	For Dial Lamp	PRM K-833553-1
222		SO-104	8 Pole Male	Power connections	K-854447-501
...					
251		1st I-F Transformer Assembly	Complete with Shield Can. Includes 18-1, 18-2, 21-1, 95	1st Det. to 1st I-F Coupling	P-720237-501
252		2nd I-F Transformer Assembly	Complete with Shield Can. Includes 20-1, 20-2, 97	1st I-F to 2nd I-F Coupling	P-720237-502
253		3rd I-F Transformer Assembly	Complete with Shield Can. Includes 20-3, 21-2, 99	2nd I-F to 3rd I-F Coupling	P-720237-503



Reference No.	Stock No.	Name of Part	Description	Function	Drawing No.
254		4th I-F Transformer Assembly	Complete with Shield Can. Includes 26-2, 32, 100	3rd I-F to 2nd Det. Coupling	P-720237-504
255		Crystal Filter Assembly	Complete with Shield Can. Includes 7, 19, 96, 105, 121	I-F Selectivity	M-420376-501
256		CW Osc. Assembly	Complete with Shield Can. Includes 8, 9-12, 22-1, 26-1, 47, 98	CW Reception	M-420377-501
257		Antenna Unit Assembly	Complete with Shield Can. Includes 2, 3-1, 3-2, 4-1, 5-1, 5-2, 10-1, 24-1, 28-1, 29-1, 31-1, 48-1, 71, 72, 73, 74, 75, 76, 108, 109	Antenna to 1st R-F Tube Coupling	P-720235-501
258		R-F Unit Assembly	Complete with Shield Can. Includes 3-3, 3-4, 4-2, 4-3, 5-3, 5-4, 10-2, 10-3, 24-2, 28-2, 29-2, 31-2, 42-1, 48-2, 77, 78, 79, 80, 81, 82, 110, 111	1st R-F to 2nd R-F Tube Coupling	P-720234-501
259		Det. Unit Assembly	Complete with Shield Can. Includes 3-5, 3-6, 4-4, 4-5, 5-5, 5-6, 10-4, 24-3, 28-3, 29-3, 31-3, 42-2, 83, 84, 85, 86, 87, 88, 112, 113	2nd R-F to 1st Det. Tube Coupling	P-720234-502
260		Osc. Unit Assembly	Complete with Shield Can. Includes 3-7, 3-8, 6-1, 6-2, 6-3, 6-4, 11-1, 11-2, 13, 14, 16, 17, 23, 27, 30, 33, 34.	Heterodyne Osc. to 1st Det. Coupling	P-720255-501

Reference No.	Stock No.	Name of Part	Description	Function	Drawing No.
260 cont'd		Osc. Unit Assembly	35, 36, 37, 41-1, 45, 48-3, 89, 90, 91, 92, 93, 94, 114, 115, 116, 117, 214, 217	Heterodyne Osc. to 1st Det. Coupling	P-720255-501
...					
271		Resistor Board	17 Terminal	Supports Parts 12, 42-6, 44, 48-4, 56, 57	P-720254-502
272		Resistor Board	32 Terminal	Supports Parts 9-13, 9-14, 9-15, 9-16, 9-18, 15-1, 15-2, 41-2, 42-7, 46, 49, 51, 54, 61	P-720254-503
273		Resistor Board	14 Terminal	Supports Parts 9-9, 9-10, 9-11, 40-4, 42-4, 42-5, 50-3	P-720254-501
274		Resistor Board	14 Terminal	Supports Parts 9,6, 9-7, 42-3, 43-4, 50-2, 55, 62	P-720254-504
...					
276		Dial Mech- anism	Includes com- plete with Mask, Index, Gear Drive, Stop and Detent Mechanism	Frequency Indicator, Tuning Condenser Drive	T-620121-501
...					
300*	3H1624B	DM-24-B	13.8V, 2.45A; 220V, 0.070A; 4,400 r.p.m., Type 1-1019A	Dynamotor Machine	E K-850764-501
301		Choke	R-F	Filter for Dynamotor DM-24-B	K-850610-501
302		Choke	R-F	Filter for Dynamotor DM-24-B	M-66347-507
303-A		Capacitor	Oil, 250V DC, 0.5 mfd ±20%	Filter for Dynamotor DM-24-B	M-420505-3
303-B					

Reference No.	Stock No.	Name of Part	Description	Function	Drawing No.
304-1		Capacitor	Mica, 500V DC, 0.01 mfd $\pm 10\%$ , with Lugs	Filter for Dynamotor DM-24-B	M-420394-3
304-2		Capacitor	Mica, 500V DC, 0.01 mfd $\pm 10\%$ , with Lugs	Filter for Dynamotor DM-24-B	M-420394-3
305		Capacitor	Oil, 1 mfd $\pm 20\%$ 400V	Filter for Dynamotor DM-24-B	M-420505-4
306*		Armature	Part of Ref. 300, Type 5-1020A	Dynamotor	E K-854705-1
307		Bearing (Set of 2)	Part of Ref. 300, Type BRG-103	Dynamotor	E K-854705-2
308		Brush and Spring	Part of Ref. 300, Type 2-1022A	Pos. H.V.	E K-854705-3
309		Brush and Spring	Part of Ref. 300, Type 2-1023A	Neg. H.V.	E K-854705-4
310*		Brush and Spring	Part of Ref. 300, Type 2-1020A	Pos. L.V.	E K-854705-5
311*		Brush and Spring	Part of Ref. 300, Type 2-1021A	Neg. L.V.	E K-854705-6
...					
315		End Bell	Part of Ref. 300, Type 3-1030-A	Low Voltage End Bear- ing	E K-854705-7
316		End Bell	Part of Ref. 300, Type 3-1031-A	High Volt- age End Bearing	E K-854705-8
317* }		Field Windings	Part of Ref. 300, Type 7-1019-A	Dynamotor	E K-854705-9
318* }	Field Wind- ings Avail- able in pairs only				
319		Tie Bars	Part of Ref. 300, Type SCR-187	Hold Items 315, 316 to Frame	E K-854705-10
320		Brush Caps	Part of Ref. 300, Type 4-1007-A	Holds Brushes	E K-854705-11
321		Grommet	Part of Ref. 300, Type Was-128	Protects Terminal Wires	E K-854705-12

Reference No.	Stock No.	Name of Part	Description	Function	Drawing No.
322		Gasket	Part of Ref. 300, Type Gas-101	Prevents Leakage of Lubricant	E K-854705-13
323		Plate	Part of Ref. 300, Type EPL-101	Bearing Retainer	E K-854705-14
324		Cover	Part of Ref. 300, Type COV-125	Dust Cover	E K-854705-15
...					
350		Bracket and Gear Assembly	Pair of Beveled Gears and Coupling	Drives Band Change Switch	K-854354-501
351		Coupling	Flanged Collar with Rectangular Slot	Coupling Band Change Knob Shaft to Item 350	K-854356-1
352		Coupling Slide	Disk with Two Rectangular Keys	Slide Between 2 of Item 351	K-854357-1
353		Window Frame Assembly	Removable Cast Housing which Holds Dial Glass	Covers Dial Lamps	M-420365-501
...					
355		Friction Spreader	Phosphorus Bronze Spring	Prevents Controls from Turning Under Vibration	K-854351-1
356		Jack Cover Assembly	Spring Actuated Cover	Seals Jack Openings	K-850656-501
357		Bushing	Threaded Bushing	Holds Handle to Panel and Provides Bearing for Thumb Screw	K-854383-1
358		Nut	Special Locking Nut	Holds Item 357	K-854381-1
359		Thumb Screw Assembly	No. 10-24 x 9-9 32 Long (Less Knob)	Holds Chassis in Cabinet	K-854378-501
360		Nut	Special Locking Nut	Holds Upper End of Handles	K-854469-1
361		Flexible Shaft and Coupling	5 1/2 Inches Long, Including Couplings, Special	Operates B.F.O. Control	SW K-854404-1

Reference No.	Stock No.	Name of Part	Description	Function	Drawing No.
362		Extension Shaft	Special Shaft 0.594 Inches Long	Operates Crystal "ON- OFF" Switch	K-854423-1
363		Shaft and Coupling Assembly	Flexible Shaft with Insu- lated Coupl- ing	Operates Antenna Trimmer	K-854429-501
364		Switch Shaft	Flat Shaft, Type A-141645-1	Operates Band Switch	PRM K-854361-1
...					
366		Dial Mask Assembly	Plate with Cutouts	Masks Un- desired Dial Scales	M-420383-501
367		Dial As- sembly	Calibrated Circular Dial with Hub and Large Spur Gear	Gives Fre- quency set- ting	M-420384-501
368		Stop Arm Assembly	Lever with Roller and Pawl	Stops Con- denser at End of Travel	K-854308-501
369		Index Plate	Phosphorus Bronze Strip Painted Red	Dial Scale Index	K-854196-1
370		Stop	Cast Bushing with Key	Stops Stop Arm	K-854187-1
371		Stud	Shouldered Stud Thread- ed No. 4-40 One End	Pivot Pin for Part 368	K-854396-1
372		Guide Assembly	Arm and Roller As- sembly	Engages In- dex Wheel for Switch Locations	K-854151-501
373		Spring	Coiled Spring	Operation of Indexing Arm Item 372	K-854194-1
374		Gear and Pinion Assembly	Spur Gear and Pinion Assembly	Idler Reduc- ing Gear Between Tuning Shaft and Dial	K-854176-501
375		Pinion	Pinion (Pinned to Tuning Shaft)	Dial Drive Pinion Meshing with Item 374	K-854188-1
376		Worm	Worm, Single Pitch	Drives Cross Shaft of Condenser Drive	K-854191-1

Reference No.	Stock No.	Name of Part	Description	Function	Drawing No.
377		Gear Assembly	Split Worm Wheel	Part of Condenser Drive Train	K-854321-501
378		Pinion and Bushing Assembly	Pinion on Cross Shaft	Drives Tuning Condenser Gear	K-854391-501
379		Spring	Torsion Spring	Holds Items 368	K-854399-1
380		"C" Washer	"C" Washer	Against Dial Used to Retain Items 372 and 374	K-61933-4
...					
399	2Z6694B	FT-154-B	Mounting Base Assembly	Supports Receiver	M-420399-501
400		Mounting Plate Assembly	Part of Reference 399	Supports Item 401	M-420373-501
401		Base and Stiffener Assembly	Part of Reference 399	Supports Receiver and Plug—Item 403 or 404	T-620119-501
402		Cap Screw	1/4-20 x 1-1/16 Long		K-850544-1
403	2Z7203.2	PL-P103	8 Pole Female Power Connector	Makes Connection to Exterior Equipment	SC-D-2131-B SC-D-2129-B
404	2Z7203.1	PL-Q103	8 Pole Female Power Connector	Makes Connection to Exterior Equipment	SC-D-2128-B SC-D-2129-B
405		Jack Block	Part of Ref. 403 and 404	Holds Contactors	K-854301-1
406		Jack Block	Part of Ref. 403 and 404	Holds Contactors	K-854301-2
407		Jack Block	Part of Ref. 403 and 404	Holds Contactors	K-854301-3
408		Jack Block	Part of Ref. 403 and 404	Holds Contactors	K-854301-4
409		Jack Housing Assembly	Part of Ref. 403 and 404	Houses Jack Blocks	K-829037-502
410	2Z7203.1 1	Fitting (Right Angle)	Part of Ref. 404	Cable Protection and Shielding	K-833568-1
411	2Z7203.2 1	Fitting (Straight)	Part of Ref. 403	Cable Protection and Shielding	K-833569-1
412	2Z7203 5.1	Contact Spring Assembly	Part of Ref. 403 and 404	Contact	K-829766-502

Reference No.	Stock No.	Name of Part	Description	Function	Drawing No.
413		Jack Housing Cover	Part of Ref. 403 and 404	Covers Jack Block Terminals	K-829856-502
414		Cover	Part of Ref. 257	Top	K-850750-3
415		Cover	Part of Ref. 257	Bottom	K-850750-4
416		Shield	Part of Ref. 257	Side and Ends	P-720228-1
417		Cover	Part of Ref. 258	Top	K-850750-1
418		Cover	Part of Ref. 258	Bottom	K-850750-4
419		Shield	Part of Ref. 258	Side and Ends	P-720229-1
420		Cover	Part of Ref. 259	Top	K-850750-1
421		Cover	Part of Ref. 259	Bottom	K-850750-4
422		Shield	Part of Ref. 259	Side and Ends	P-720229-2
423		Cover	Part of Ref. 260	Top	K-854449-1
424		Cover	Part of Ref. 260	Bottom	K-854450-1
425		Cover	Part of Ref. 260	Side	P-720252-501
426		Shield	Part of Ref. 260	Side and Ends	P-720250-1
427		Shield Can	Part of Ref. 251	Top	K-78945-2
428		Shield Can	Part of Ref. 252	Top	K-78945-2
429		Shield Can	Part of Ref. 253	Top	K-78945-2
430		Shield Can	Part of Ref. 254	Top	K-78945-1
431		Shield Can	Part of Ref. 255	Top	K-78945-11
432		Shield Can	Part of Ref. 256	Top	K-78945-1
433		Tube Guide	Cylindrical Socket for Tube Base	Supports Tube VT-70 and Tube Shield	K-833564-502
434		Tube Guide	Cylindrical Socket for Tube Base	Supports Tube VT-48	K-833564-501
435		Shield Can —Less Top	Part of Ref. 251	1st I-F Transformer Assembly Shield	K-854342-503

Reference No.	Stock No.	Name of Part	Description	Function	Drawing No.
436		Shield Can —Less Top	Part of Ref. 252	2nd I-F Transformer As- sembly Shield	K-854342-503
437		Shield Can —Less Top	Part of Ref. 253	3rd I-F Transformer As- sembly Shield	K-854342-503
438		Shield Can —Less Top	Part of Ref. 254	4th I-F Transformer As- sembly Shield	K-854342-503
439		Shield Can —Less Top	Part of Ref. 255	Crystal Filter Assembly Shield	K-854342-502
440		Shield Can —Less Top	Part of Ref. 256	CW Osc. Assembly	K-854342-503



## TABLE OF REPLACEABLE PARTS II

Reference No.	Stock No.	Name of Part	Description	Function	Drawing No.						
500		Resistor	Variable 200 ohms $\pm$ 10% special, 4 watts	Dial Lamp Control	PRM K-855754-1						
501-A } 501-B }		Resistor	<table style="border: none;"> <tr> <td style="border: none;">{</td> <td style="border: none;">Insulated 3 ohms <math>\pm</math> 10% Type MN-2 1.5 watts</td> <td style="border: none;">}</td> </tr> <tr> <td style="border: none;">{</td> <td style="border: none;">190 ohms <math>\pm</math> 10% Type MN-2 1.9 watts</td> <td style="border: none;">}</td> </tr> </table>	{	Insulated 3 ohms $\pm$ 10% Type MN-2 1.5 watts	}	{	190 ohms $\pm$ 10% Type MN-2 1.9 watts	}	Filament	IRC K-855770-2
{	Insulated 3 ohms $\pm$ 10% Type MN-2 1.5 watts	}									
{	190 ohms $\pm$ 10% Type MN-2 1.9 watts	}									
502	3Z1935	Fuse FU-35	5 amp., 25 volt, type 1094	Primary Power	LL K-850339-3						
503		Resistor	Insulated 60 ohms $\pm$ 10% 3.7 watts type MW-2	Dial Lamps Series	IRC K-855770-1						
504		Fuse Clip Assembly	Laminated Phenolic Strip with fuse clips	Power Fuse	K-854457-502						
...											
510	3H1628B	DM-28-B	27.9 V., 1.23 A.; 220 V., 0.070 A.; 4400 r.p.m., Type 1-1054A	Dynamotor Machine	E K-850764-502						
511		Armature	Part of Ref. 510, Type 5-1046A	Dynamotor	E K-854705-16						
512		Brush and Spring	Part of Ref. 510, Type 2-1001A	Pos. L.V.	E K-854705-17						
513		Brush and Spring	Part of Ref. 510, Type 2-1013A	Neg. L.V.	E K-854705-18						
514 } 515 }		Field Windings	Part of Ref. 510, Type 7-1048  Field Windings are available in pairs only	Dynamotor	E K-854705-19						

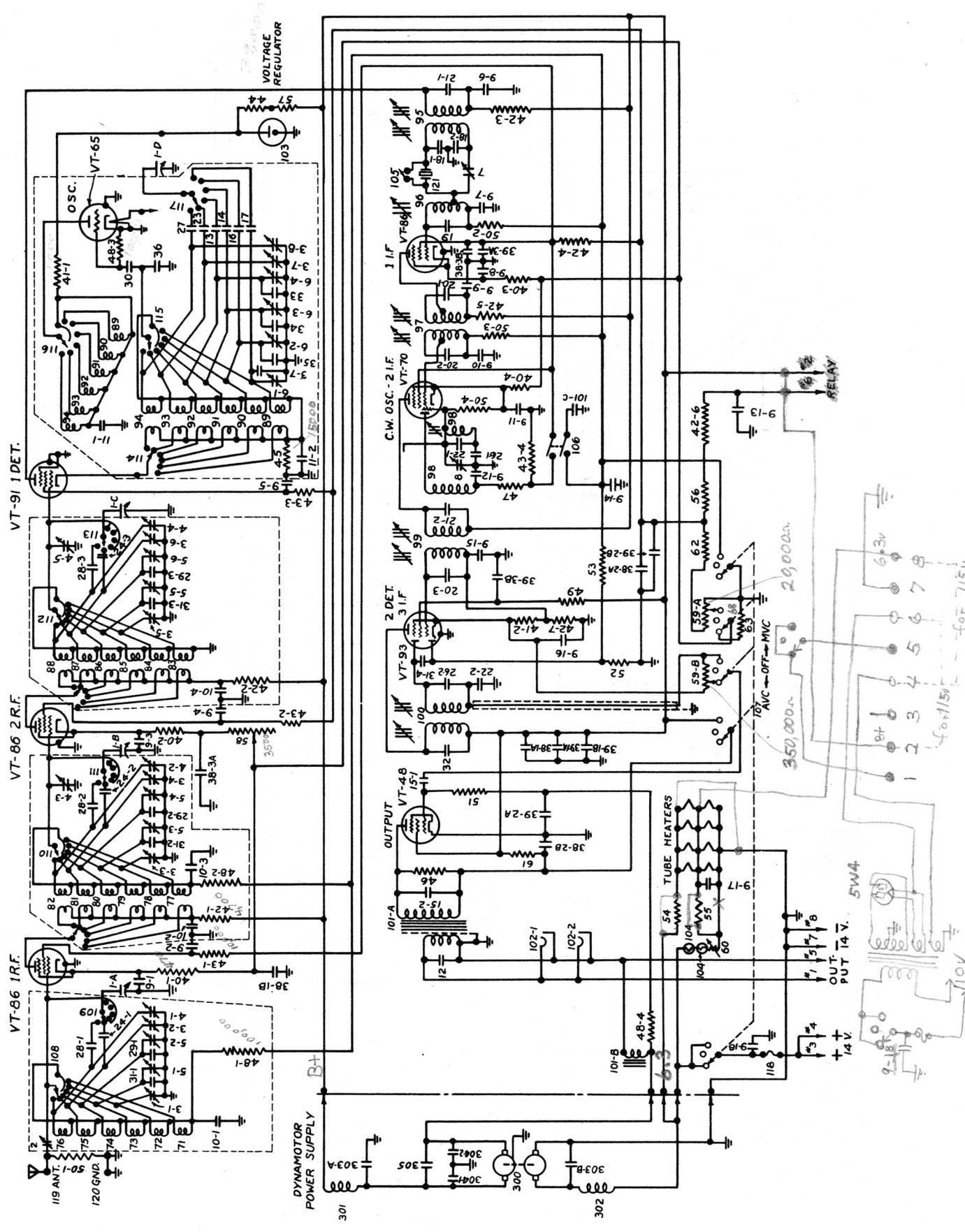

FIGURE 34—RADIO RECEIVER BC-224-B:  
SCHEMATIC CIRCUIT DIAGRAM

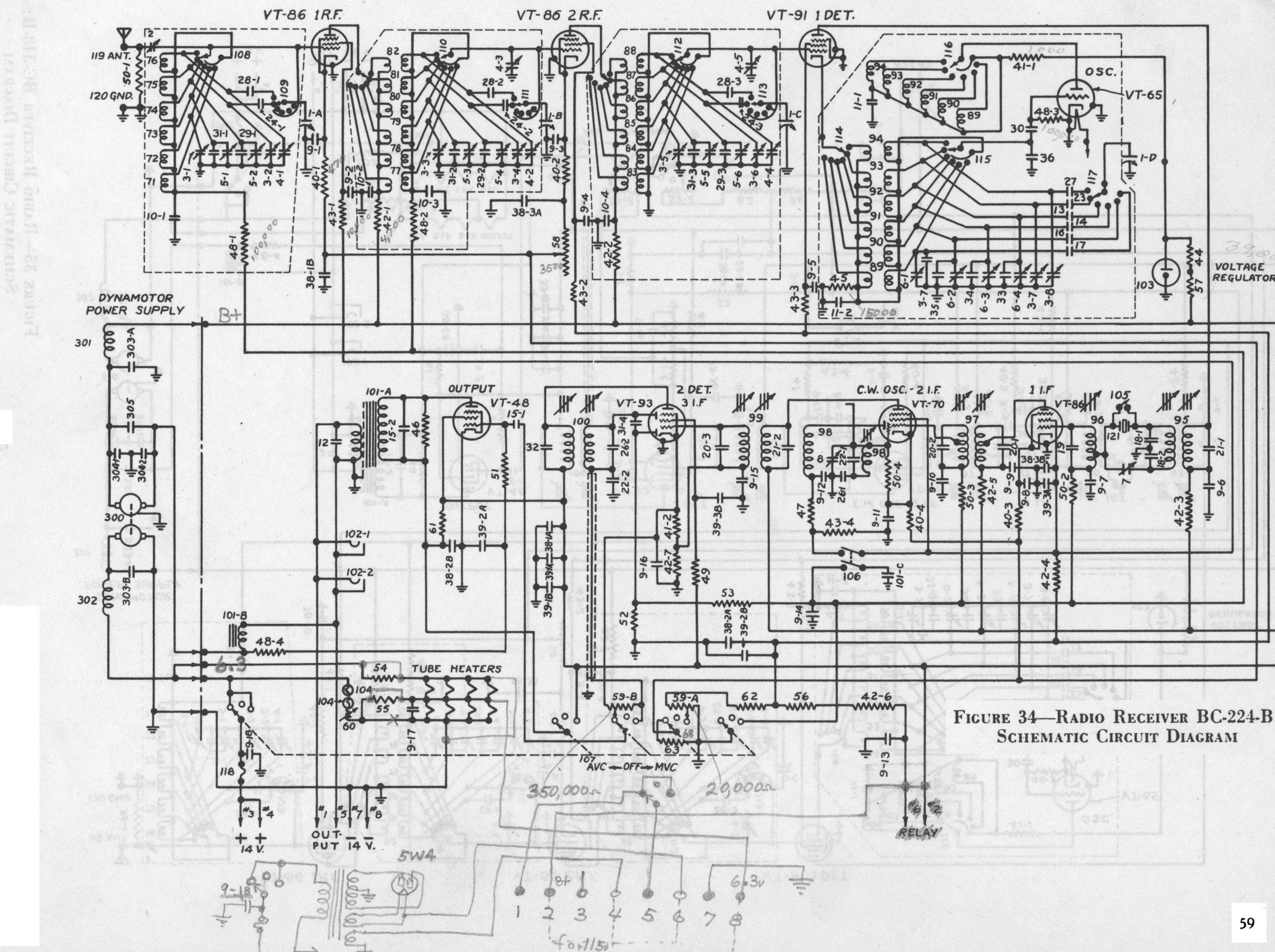

FIGURE 34—RADIO RECEIVER BC-224-B:  
SCHEMATIC CIRCUIT DIAGRAM

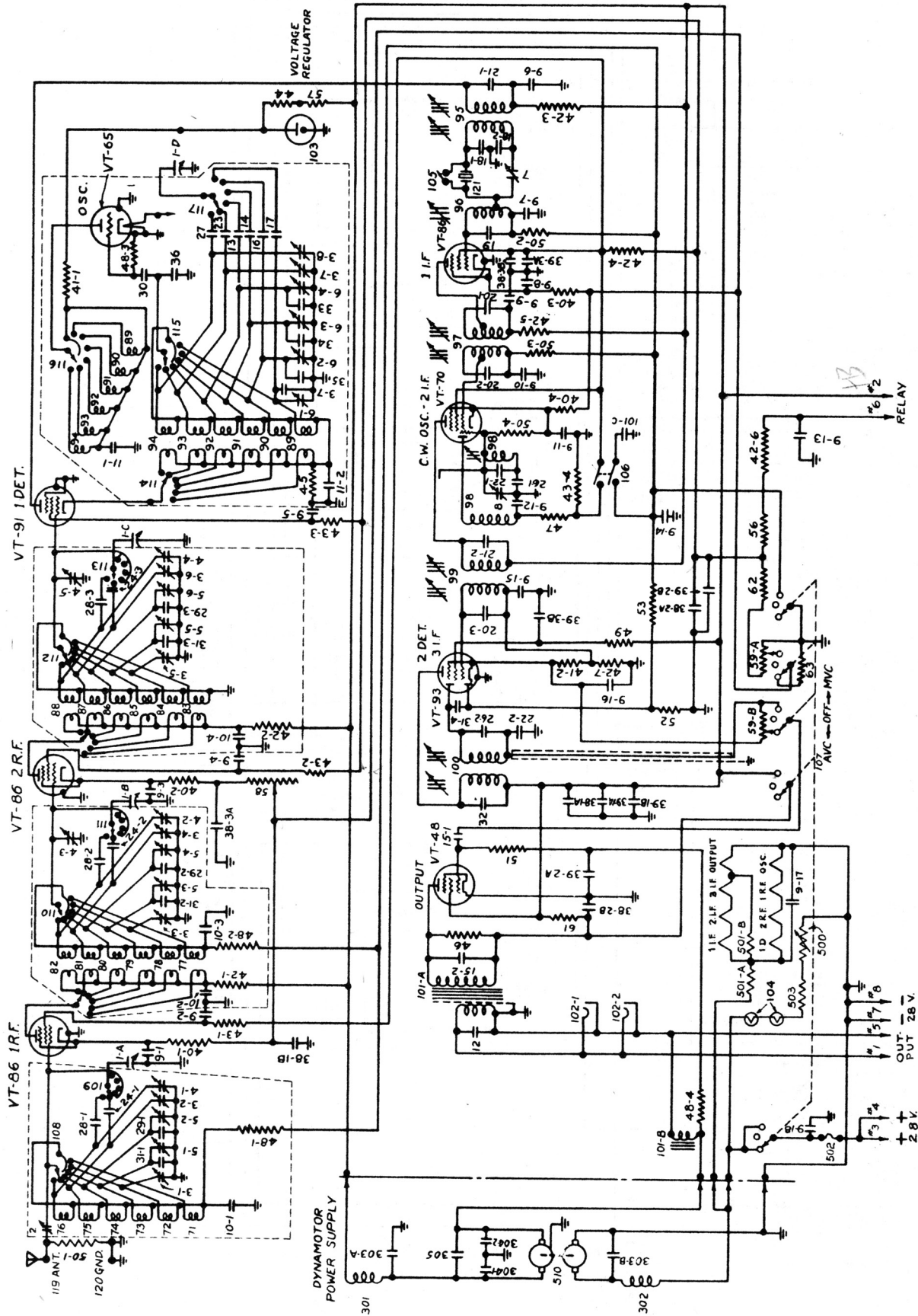

FIGURE 35—RADIO RECEIVER BC-348-B:  
SCHEMATIC CIRCUIT DIAGRAM

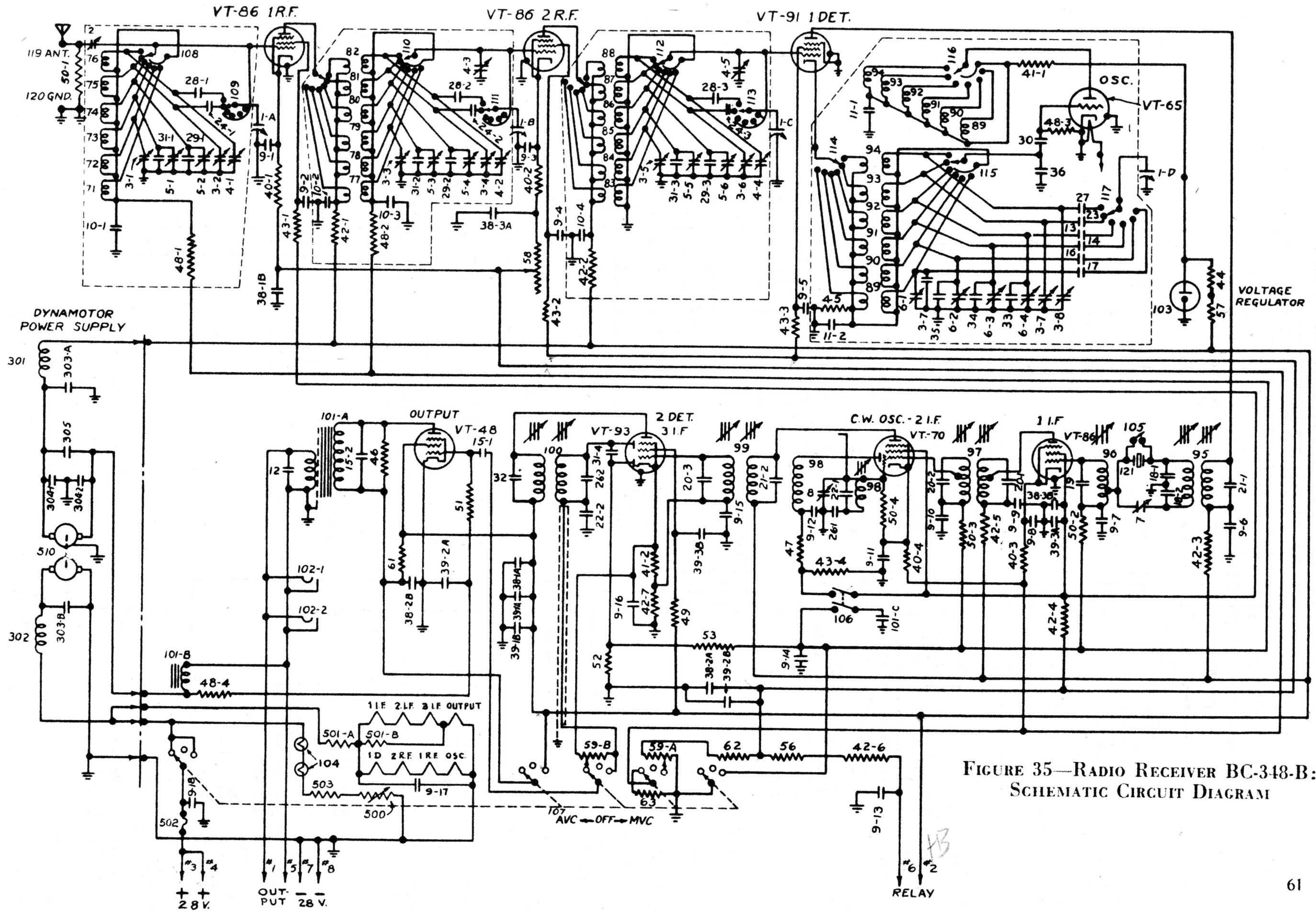
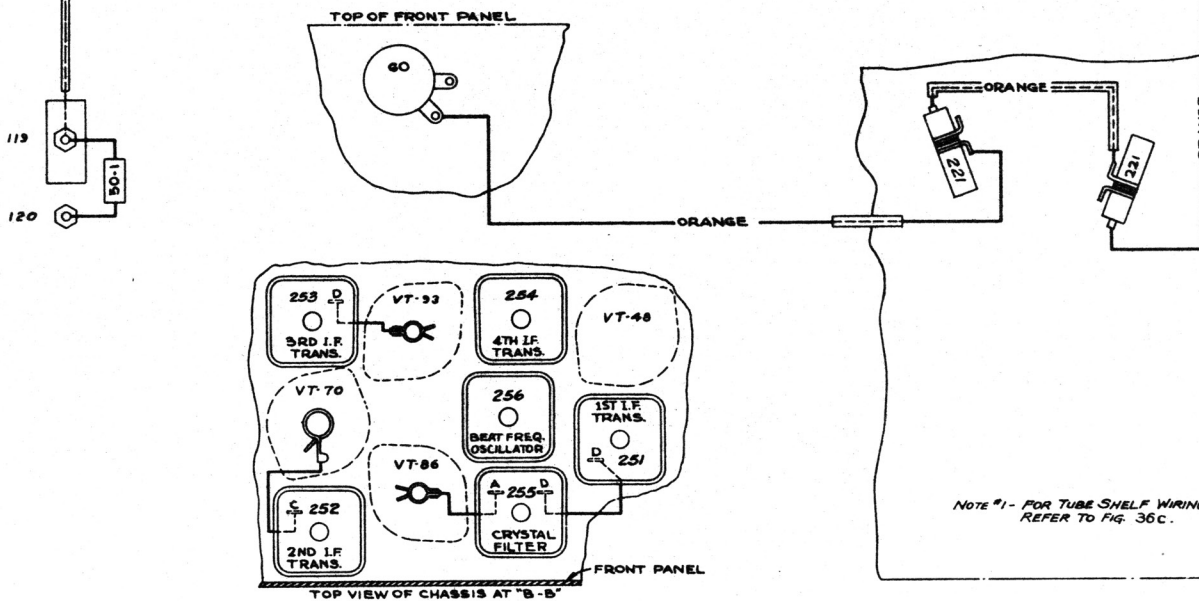
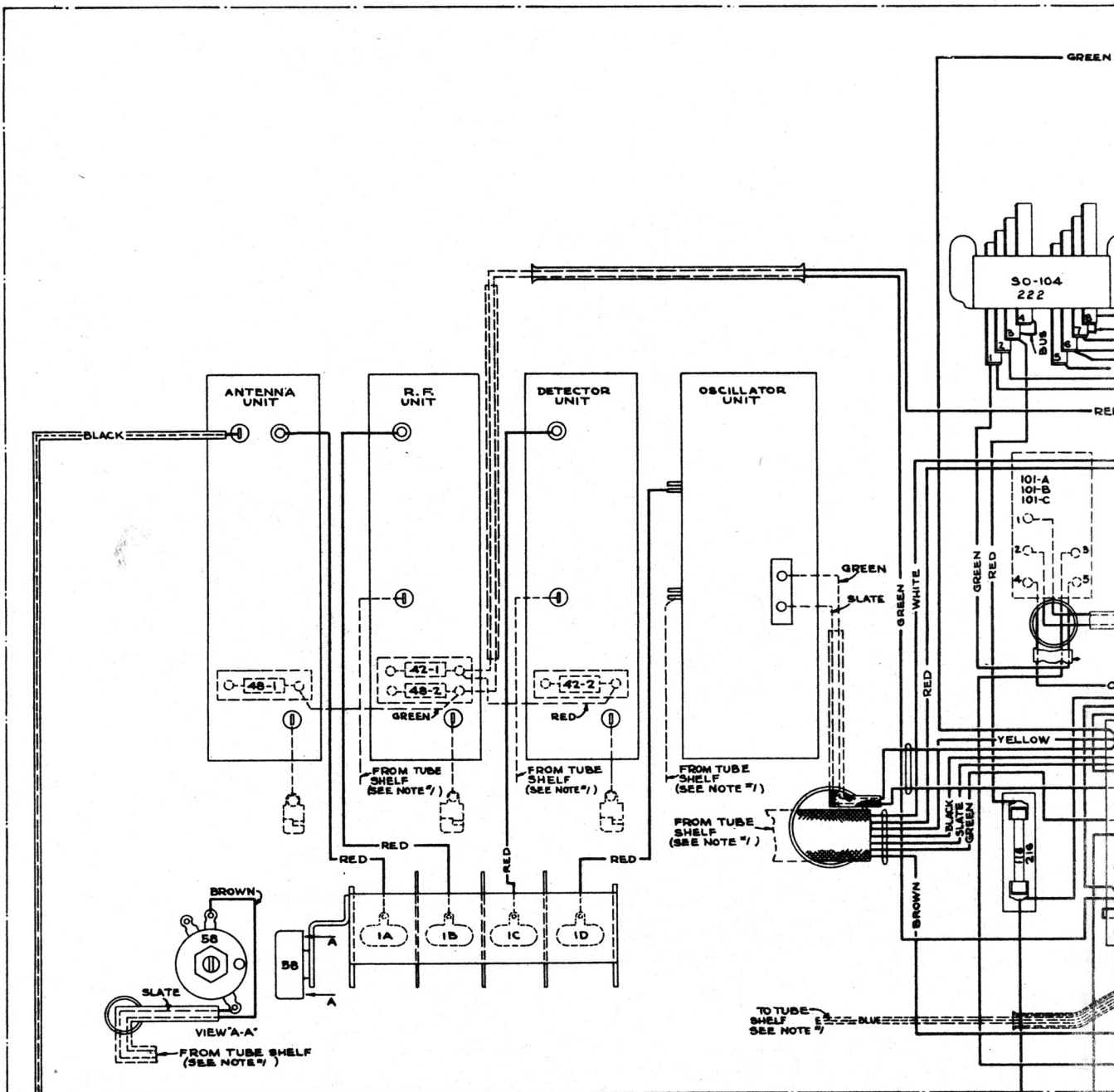

FIGURE 35—RADIO RECEIVER BC-348-B:  
SCHEMATIC CIRCUIT DIAGRAM



NOTE #1 - FOR TUBE SHELF WIRING REFER TO FIG. 36C.

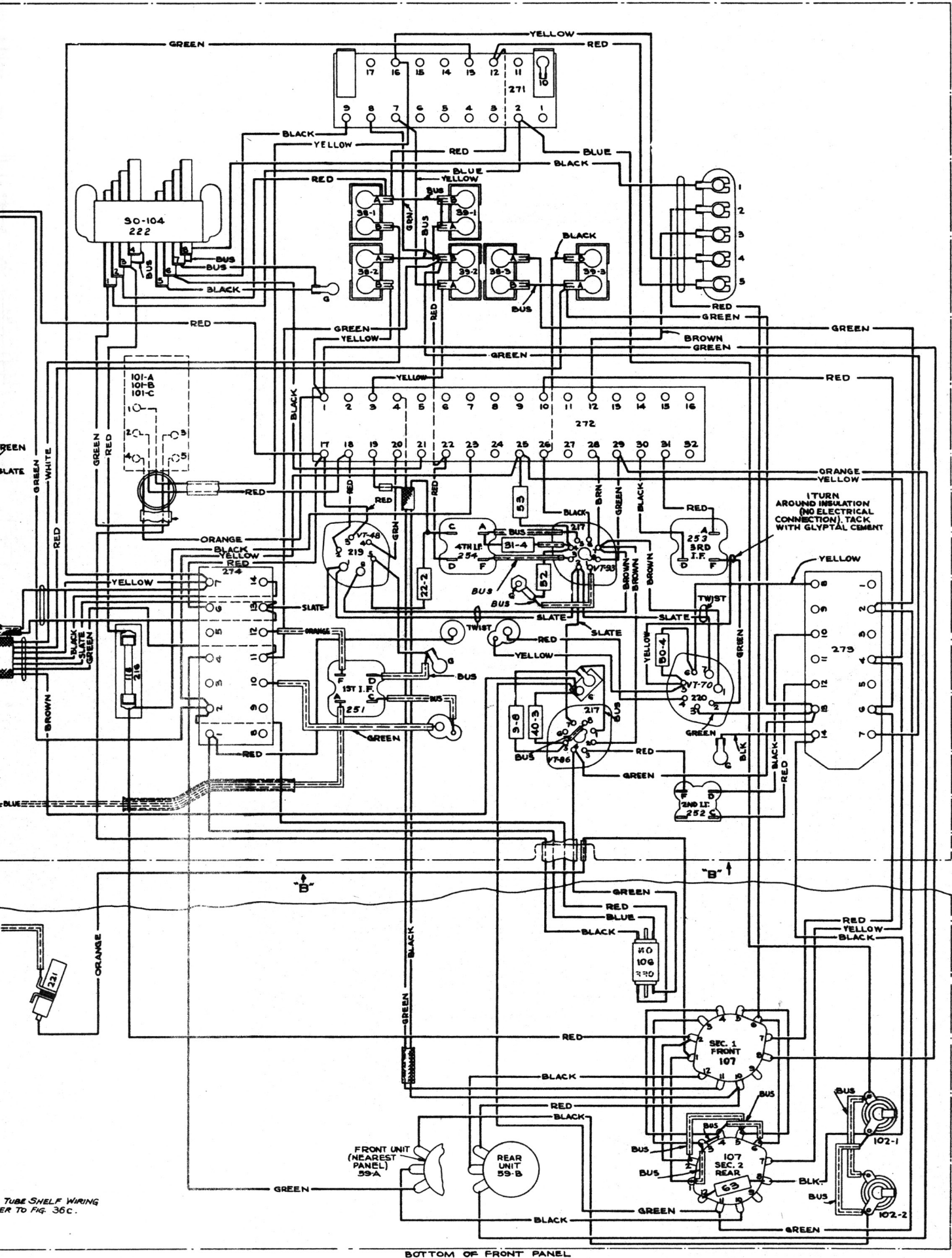

FIGURE 36A—RADIO RECEIVER BC-224-B:  
WIRING DIAGRAM

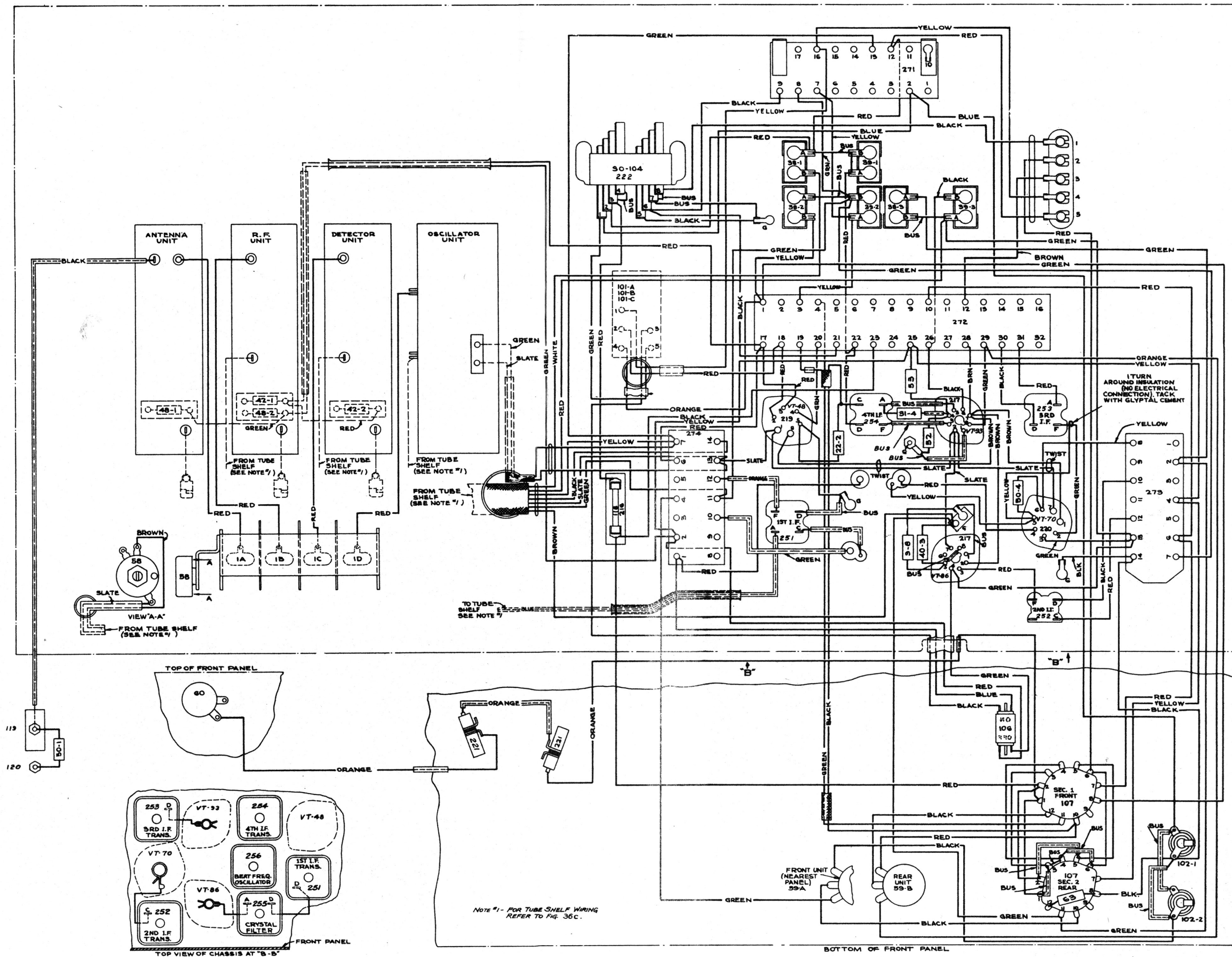
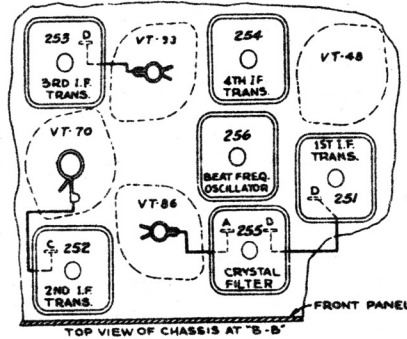
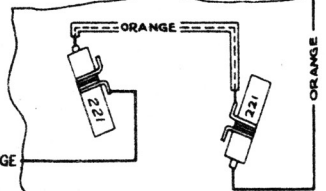
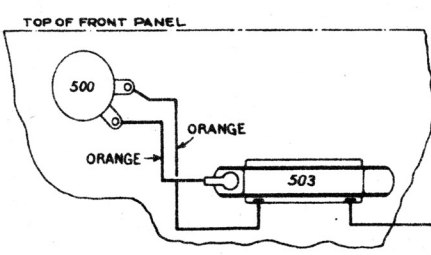
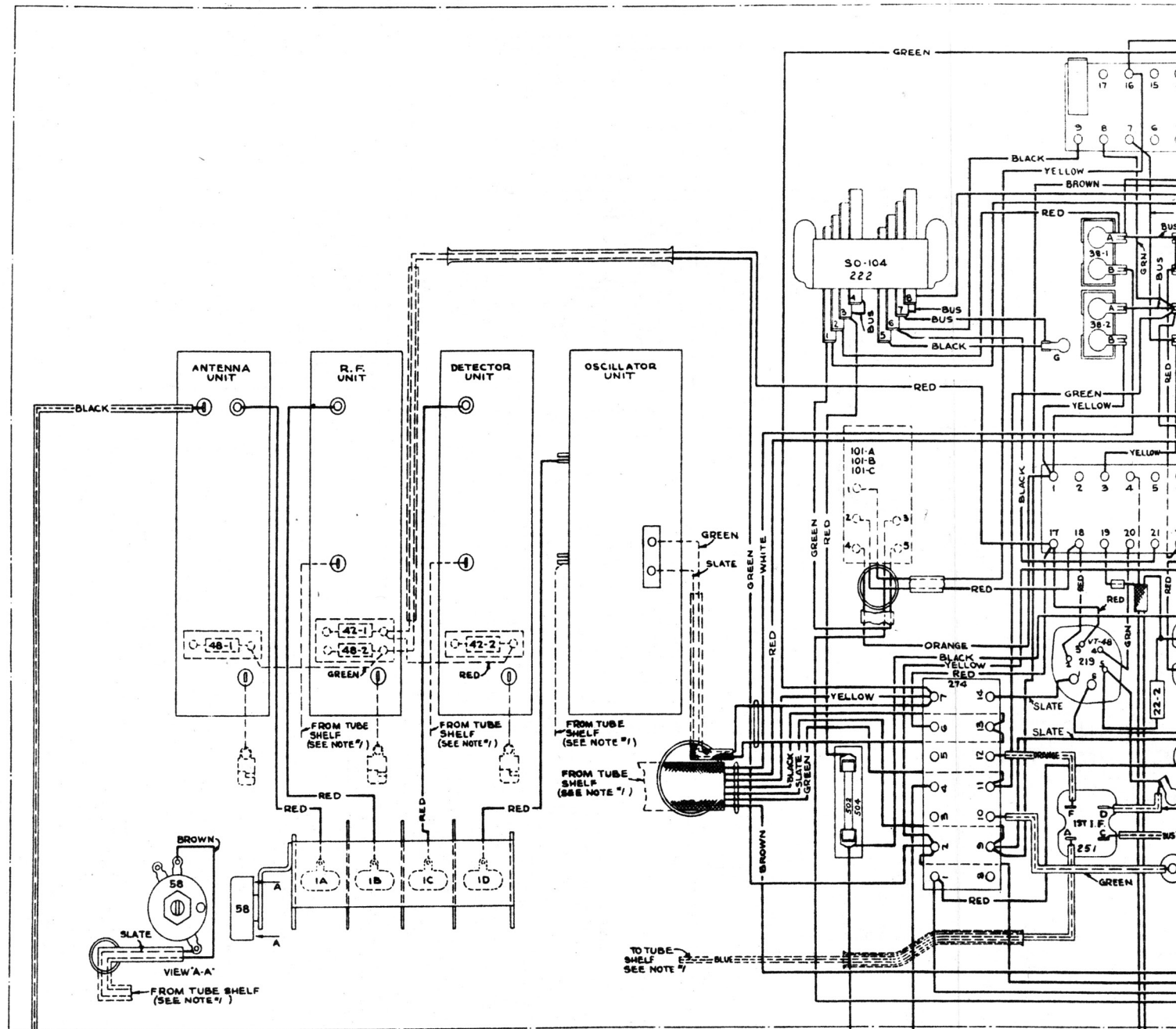

FIGURE 36A—RADIO RECEIVER BC-224-B:  
WIRING DIAGRAM





NOTE #1 - FOR TUBE SHELF WIRING REFER TO FIG. 36d

FRONT UNIT (NEAREST PANEL) 59A

BOTTOM

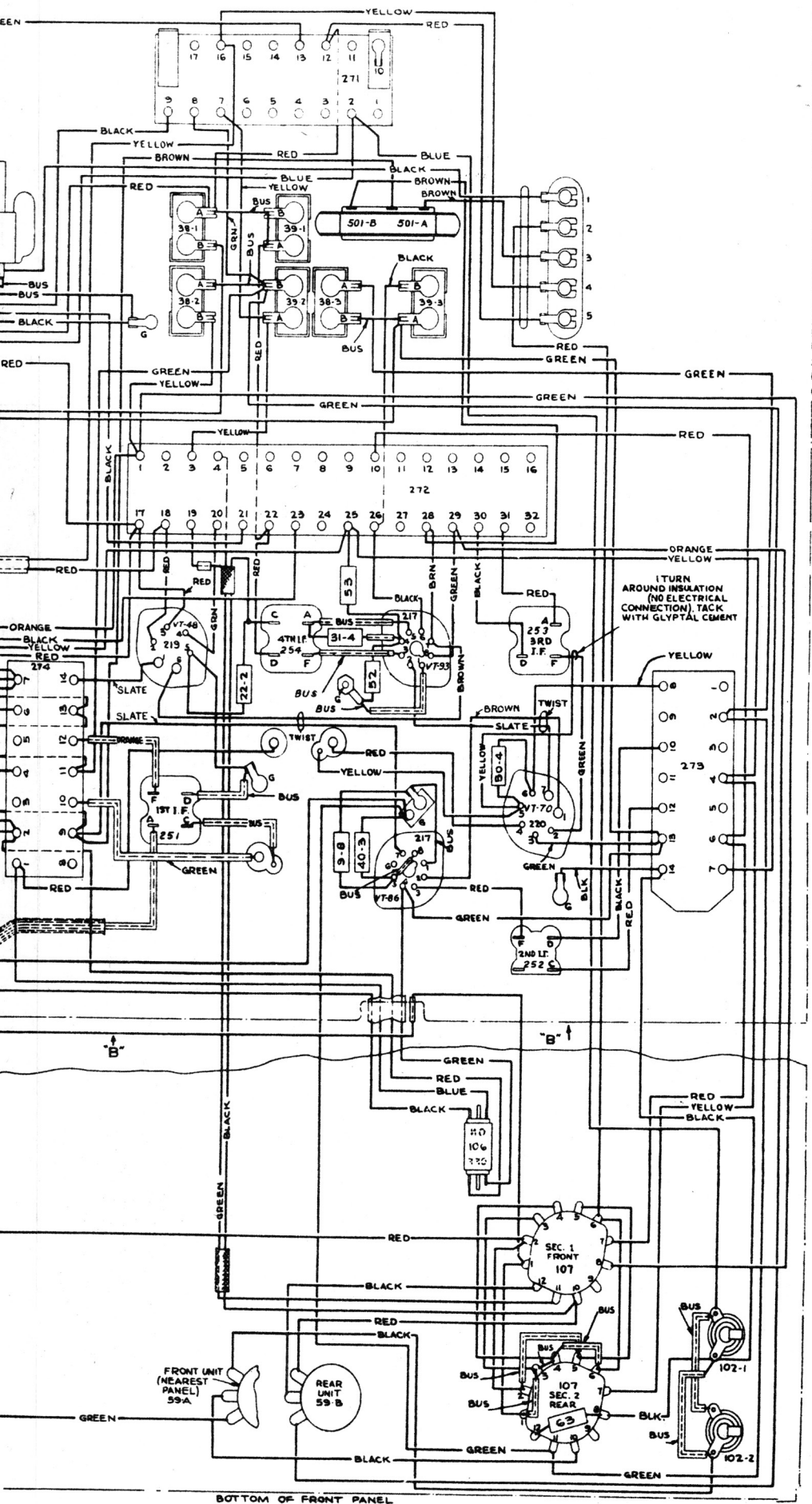

1 TURN AROUND INSULATION (NO ELECTRICAL CONNECTION). TACK WITH GLYPHTAL CEMENT

FRONT UNIT (NEAREST PANEL) 59A

REAR UNIT 59B

SEC. 1 FRONT 107

107 SEC. 2 REAR

102-1

102-2

BOTTOM OF FRONT PANEL

FIGURE 36B—RADIO RECEIVER BC-348-B: WIRING DIAGRAM

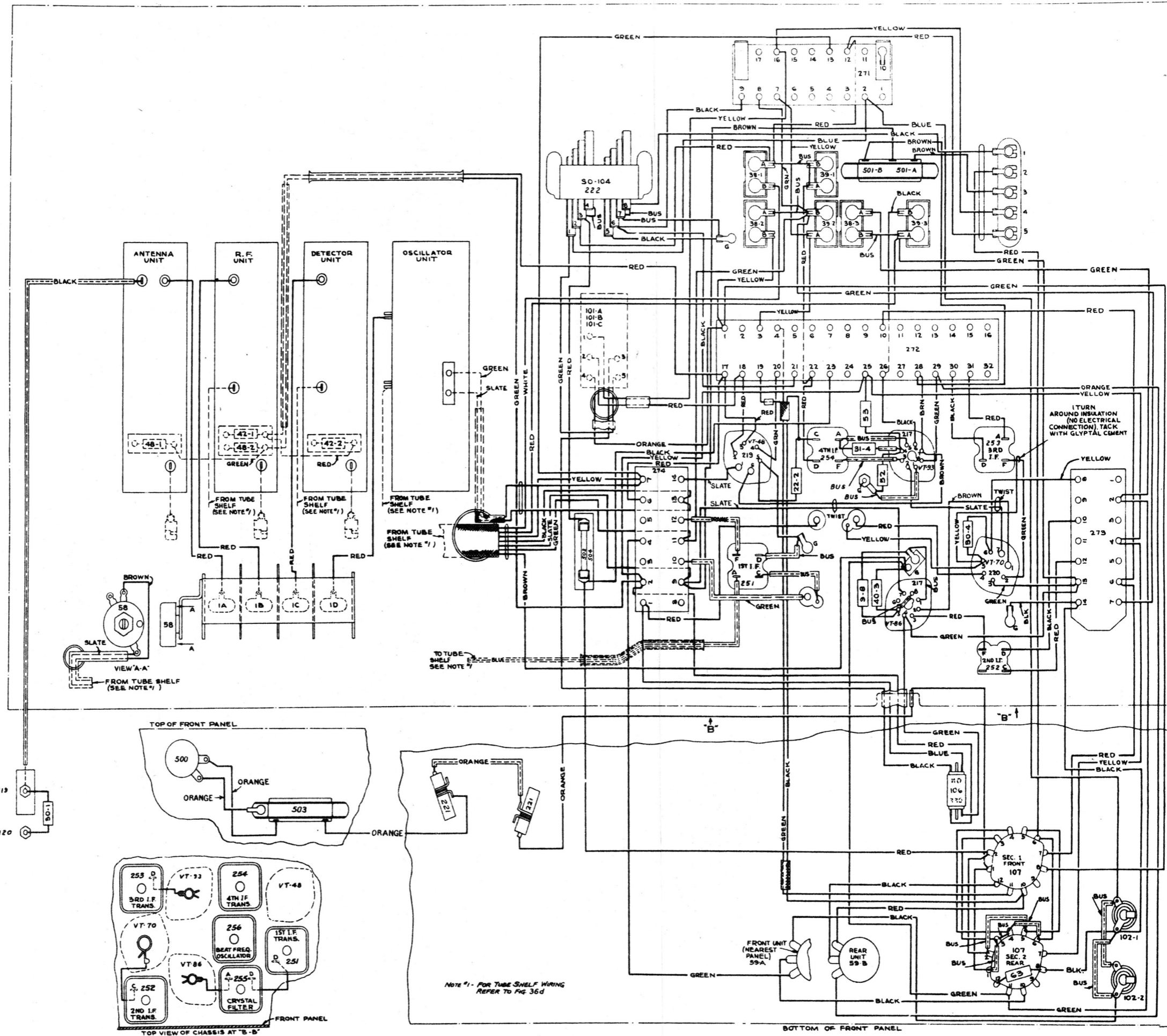
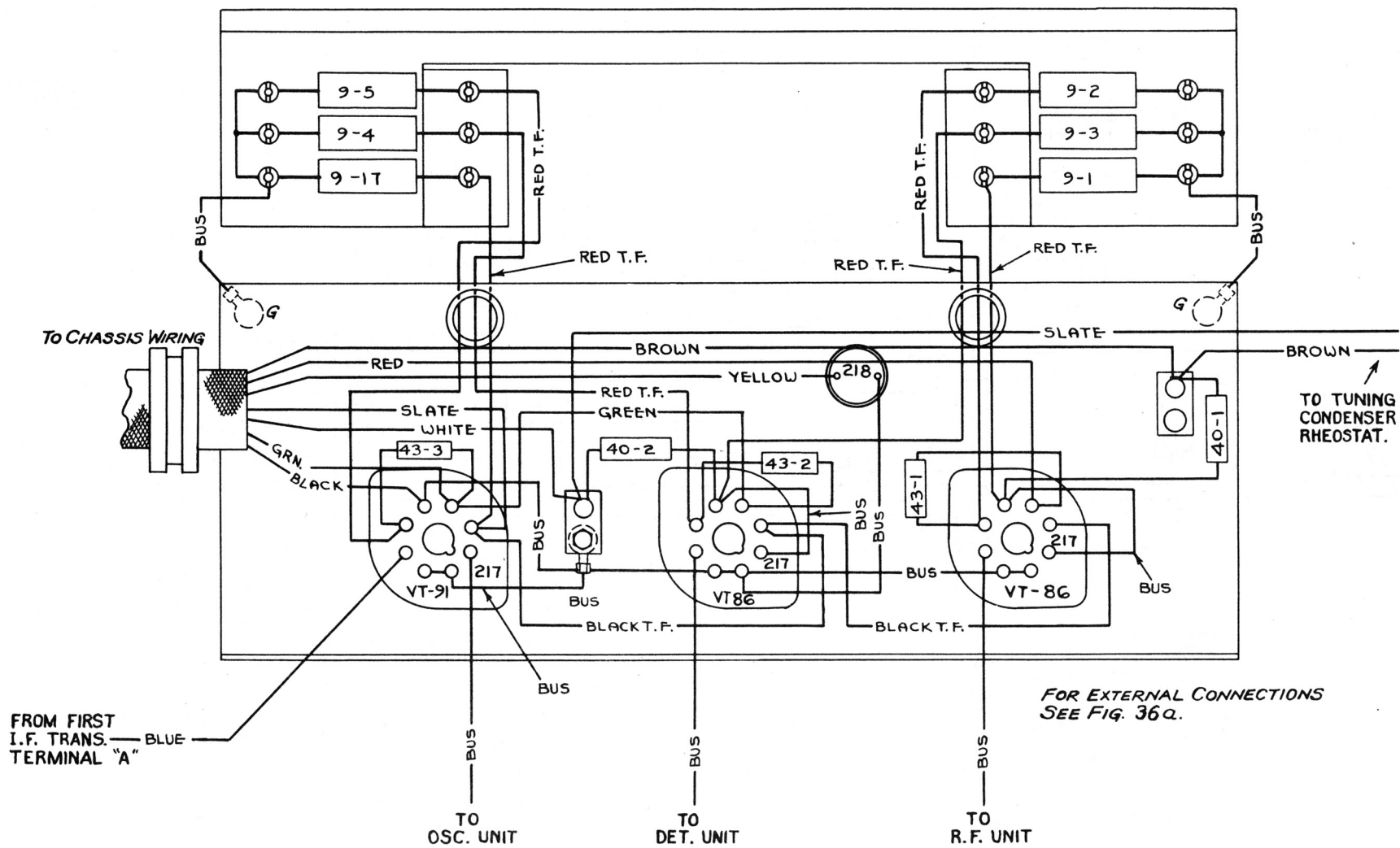

FIGURE 36B—RADIO RECEIVER BC-348-B:  
WIRING DIAGRAM

FIGURE 36C—RADIO RECEIVER BC-224-B:  
WIRING DIAGRAM, TUBE SHELF



FROM FIRST I.F. TRANS. — BLUE —  
TERMINAL "A"

TO OSC. UNIT

TO DET. UNIT

TO R.F. UNIT

FOR EXTERNAL CONNECTIONS  
SEE FIG. 36Q.

FIGURE 36D—RADIO RECEIVER BC-348-B:  
WIRING DIAGRAM, TUBE SHELF

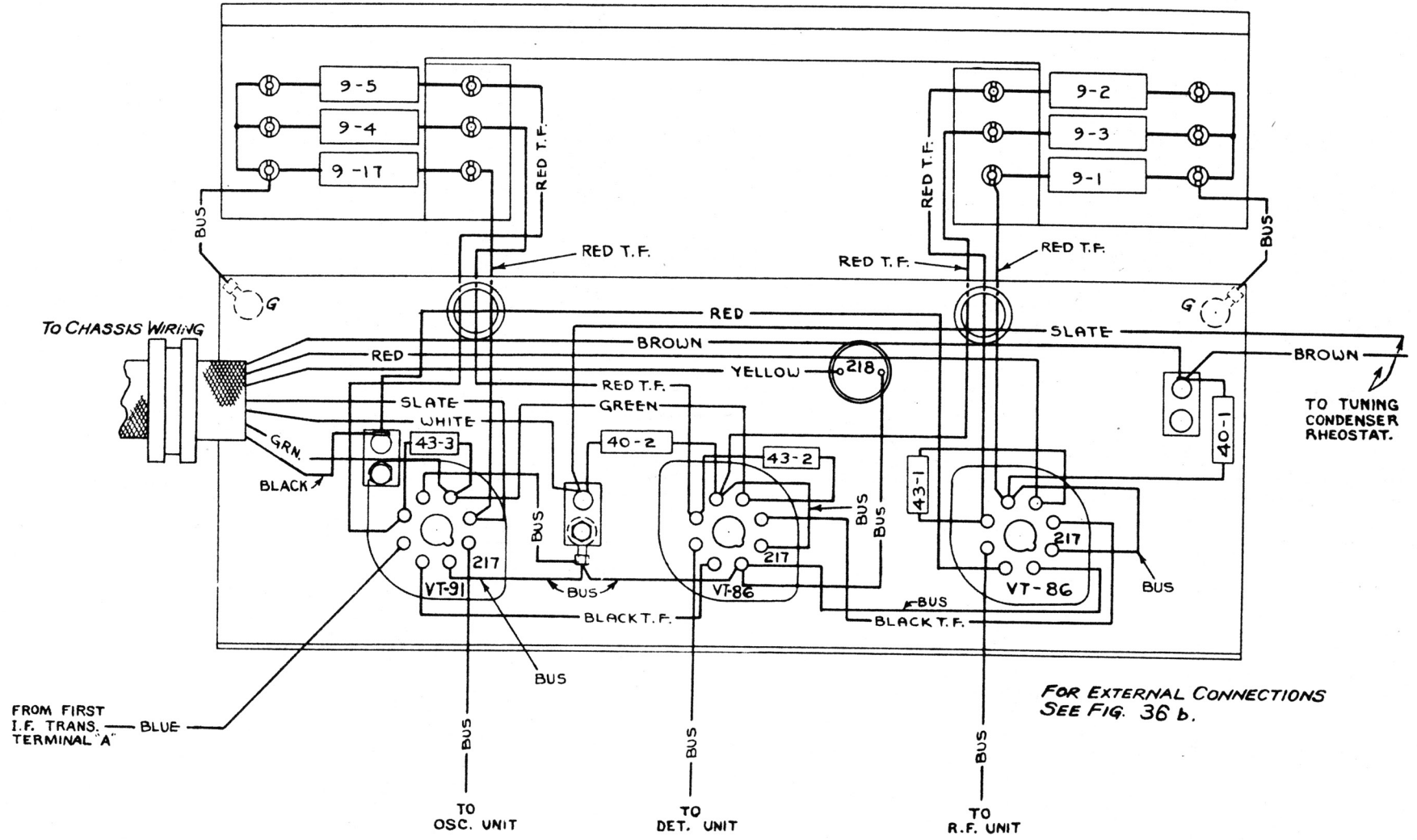

FROM FIRST I.F. TRANS. TERMINAL A

TO OSC. UNIT

TO DET. UNIT

TO R.F. UNIT

FOR EXTERNAL CONNECTIONS SEE FIG. 36 b.

TO TUNING CONDENSER RHEOSTAT.

FIGURE 36e--WIRING DIAGRAM,  
ANTENNA UNIT

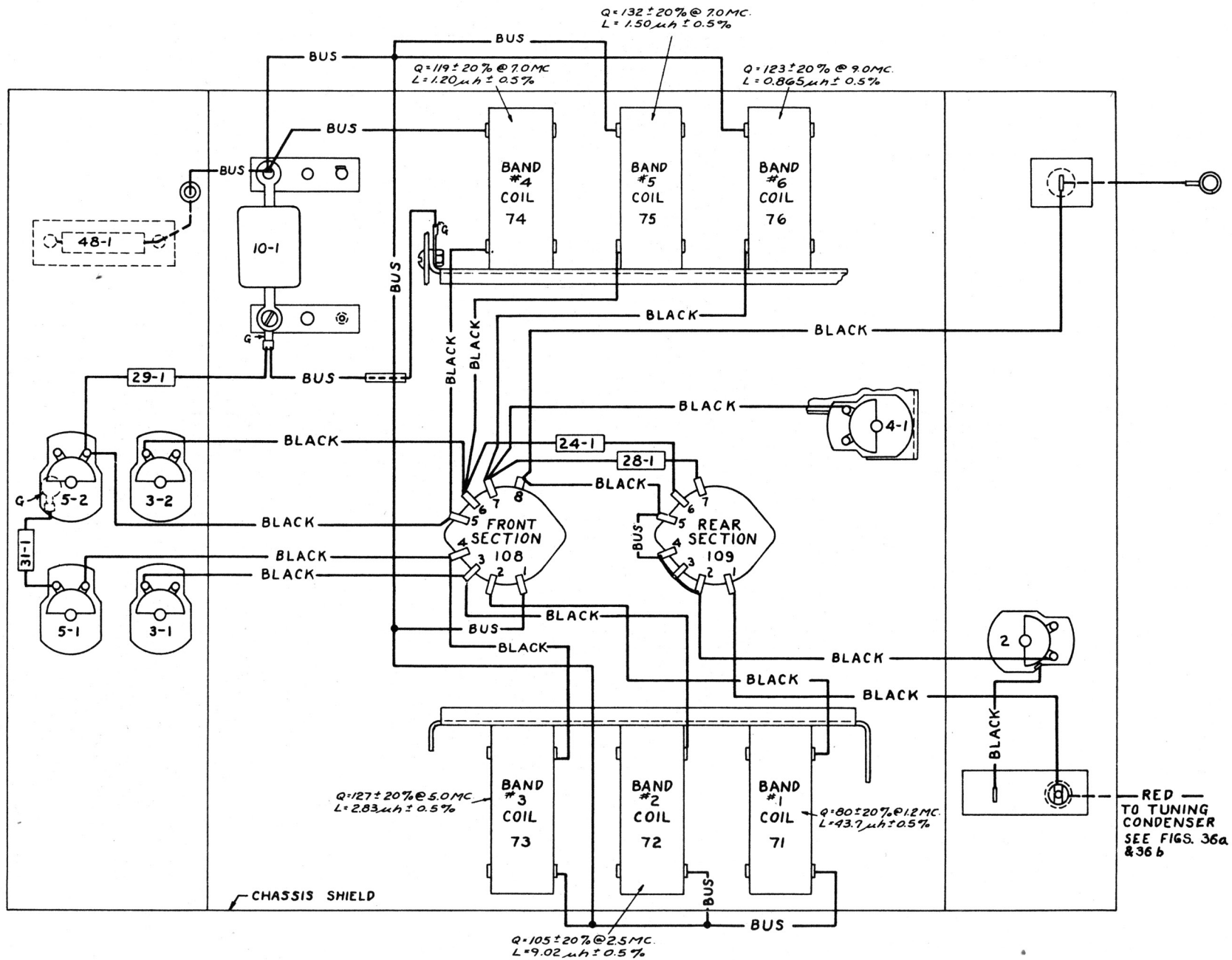

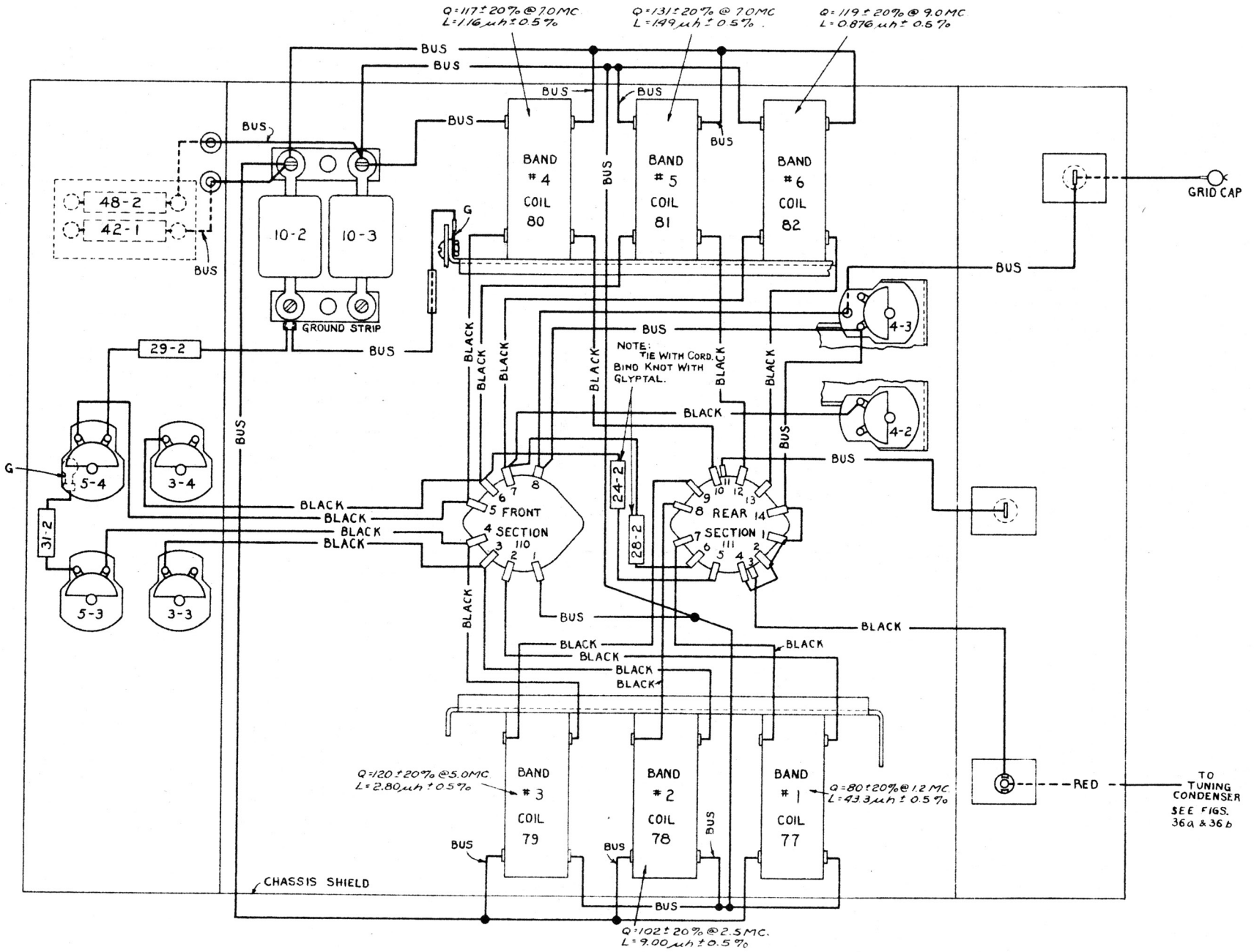

FIGURE 36F—WIRING DIAGRAM, R-F UNIT

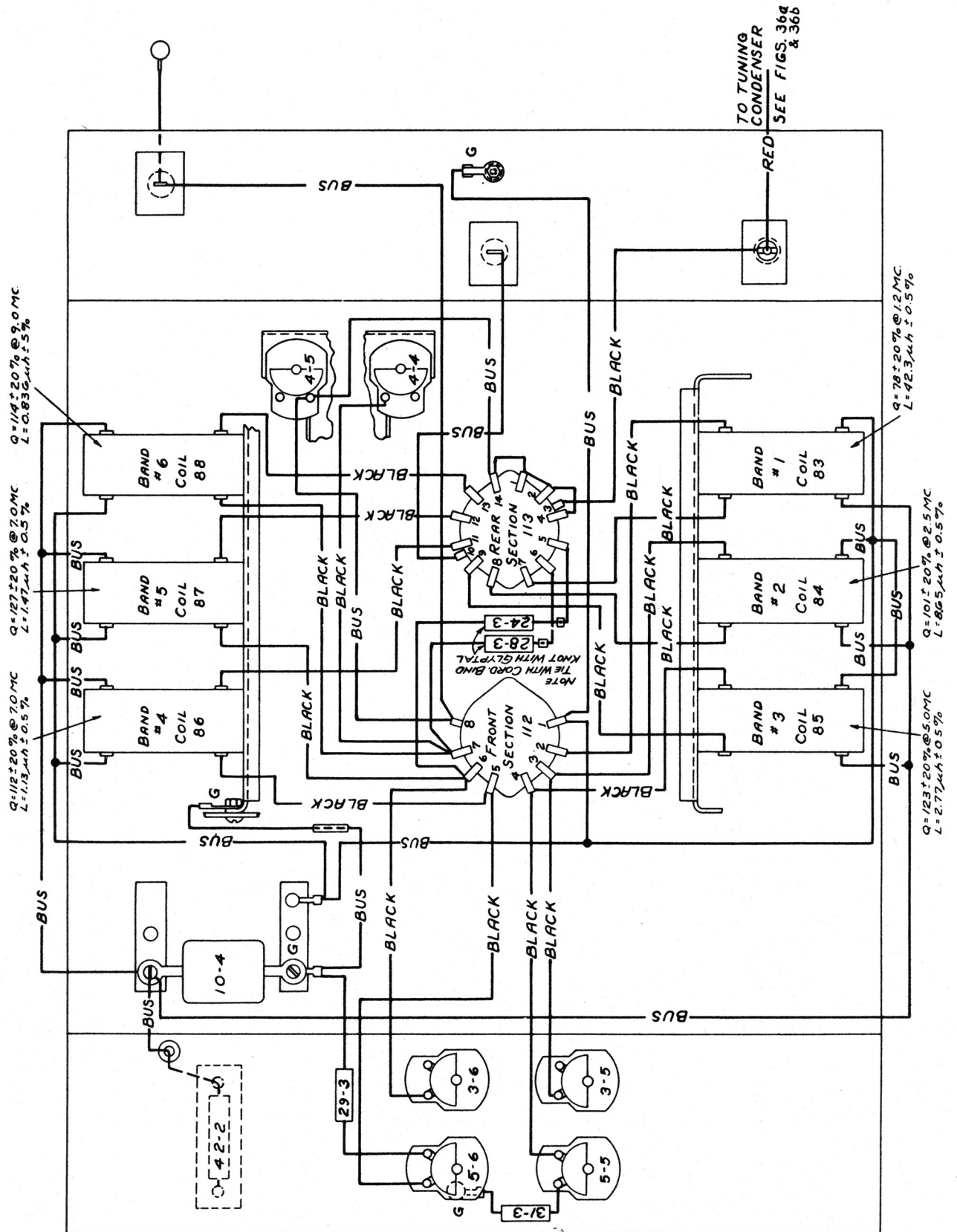

FIGURE 36C—WIRING DIAGRAM, DETECTOR UNIT



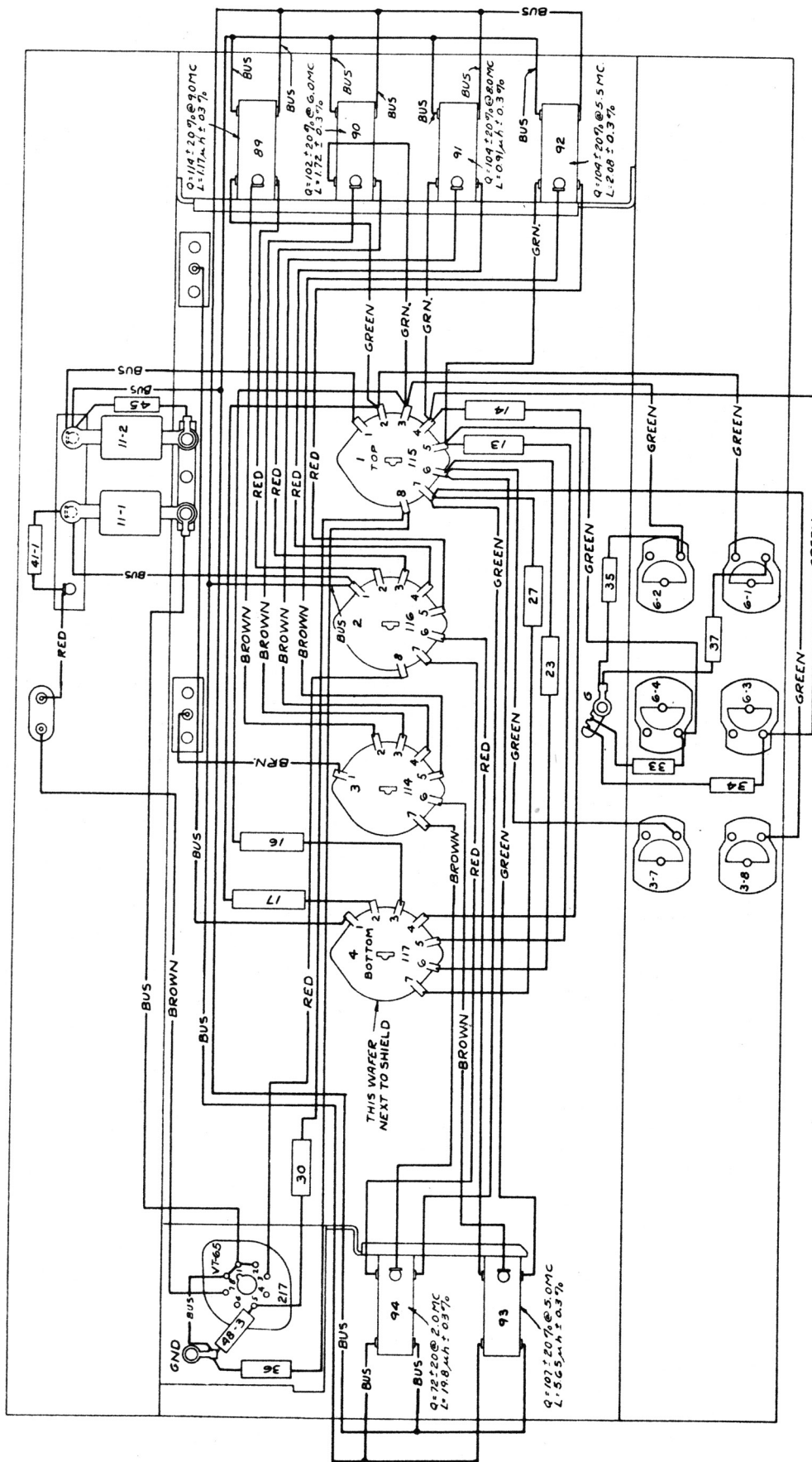

FIGURE 36H—WIRING DIAGRAM,  
OSCILLATOR UNIT

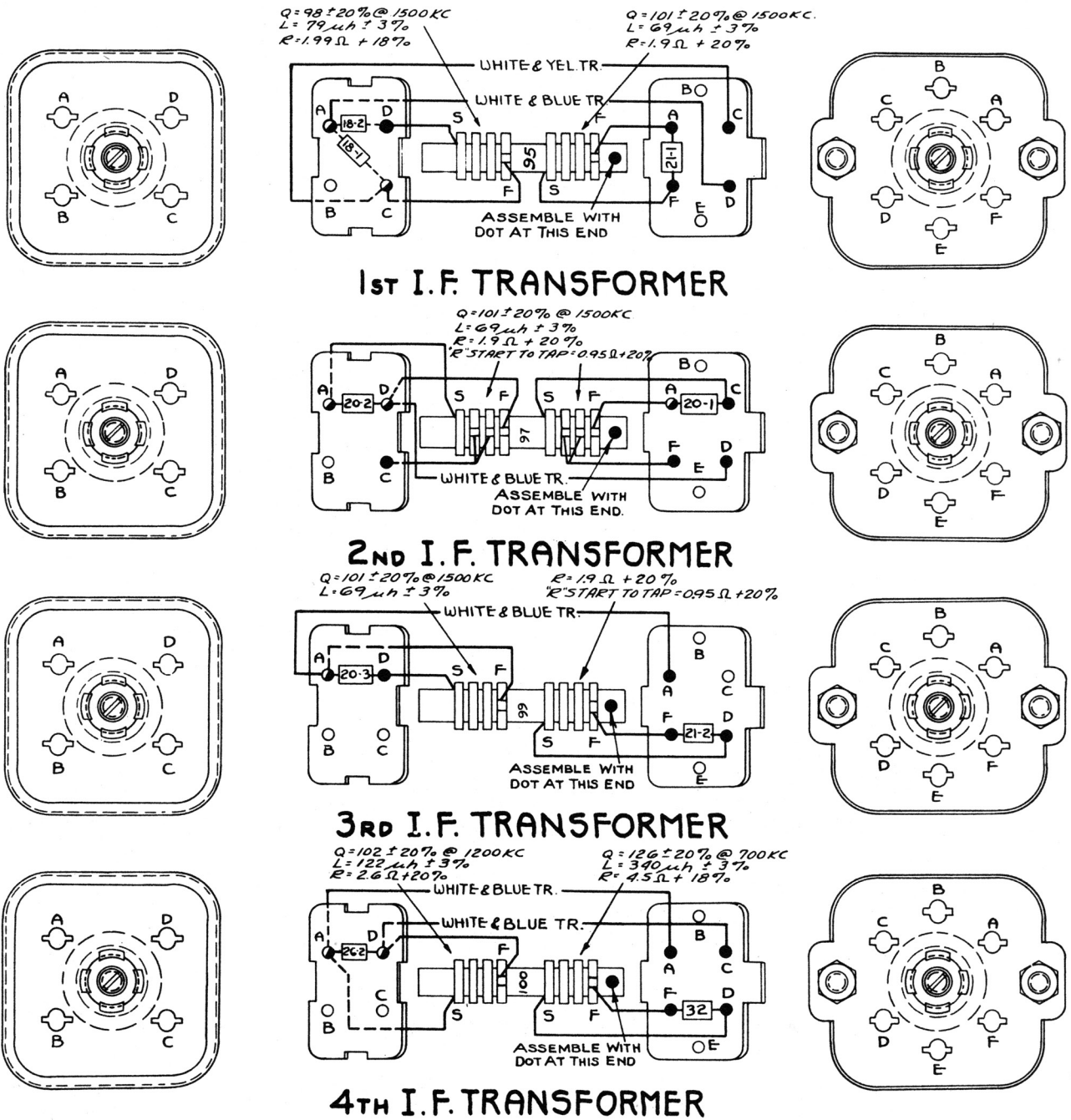

FIGURE 361—WIRING DIAGRAM, I-F TRANSFORMERS

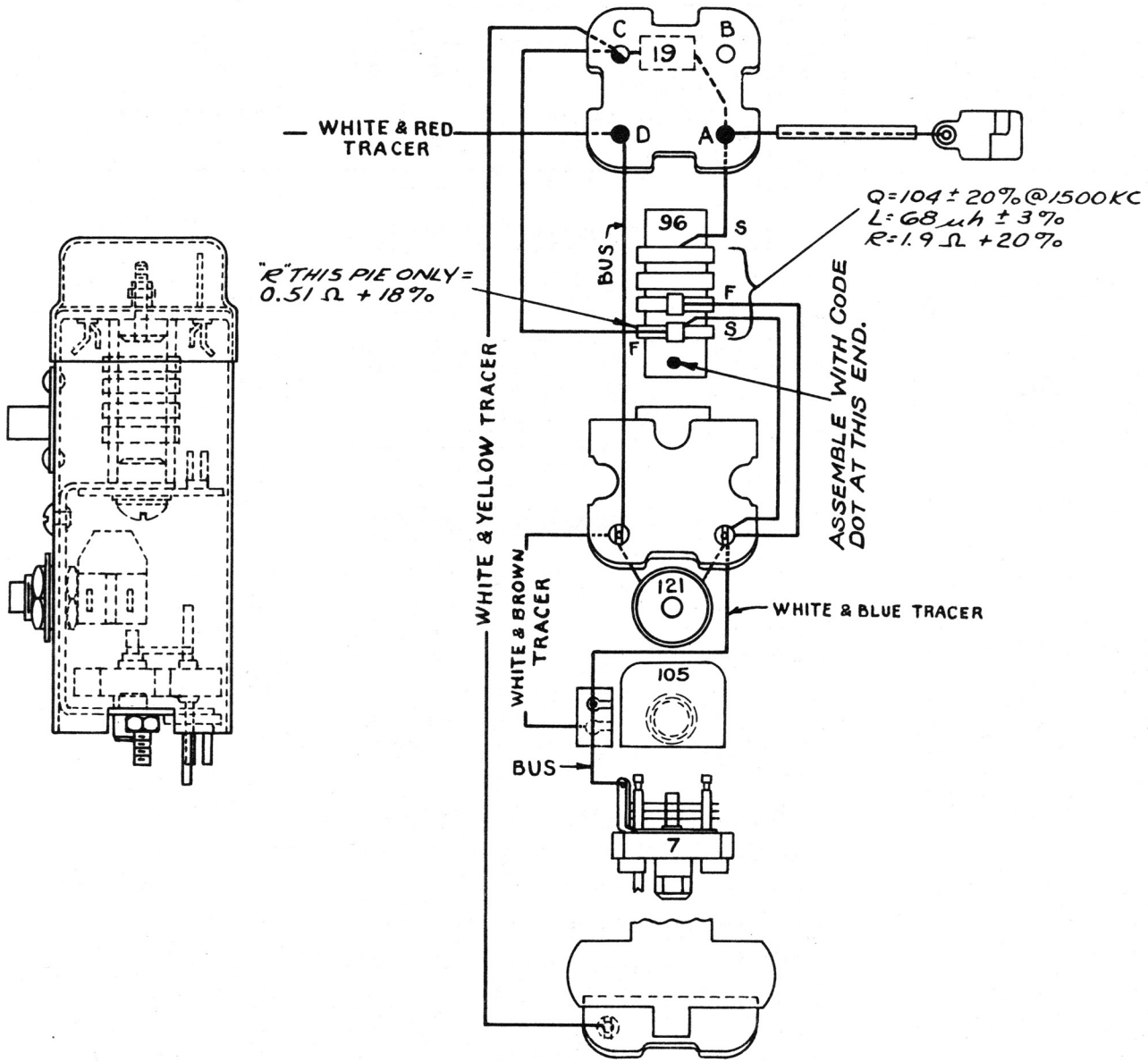

FIGURE 36J—WIRING DIAGRAM,  
 CRYSTAL FILTER

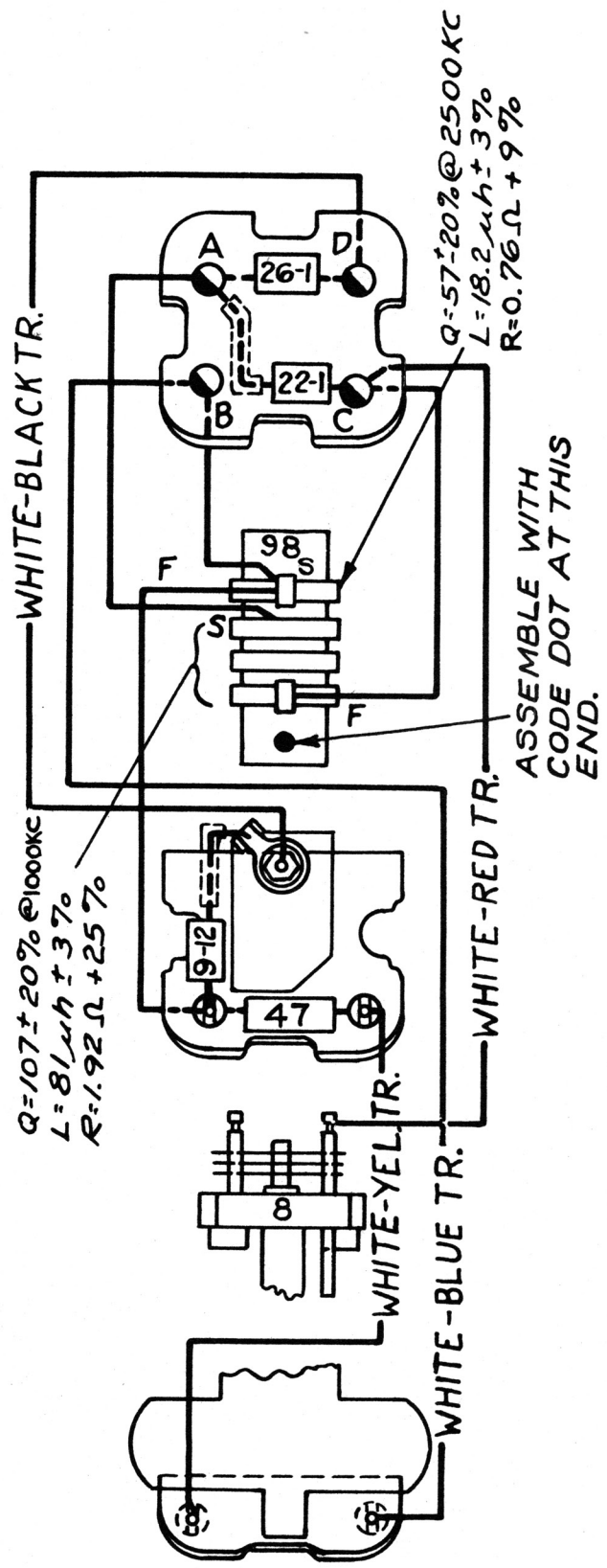
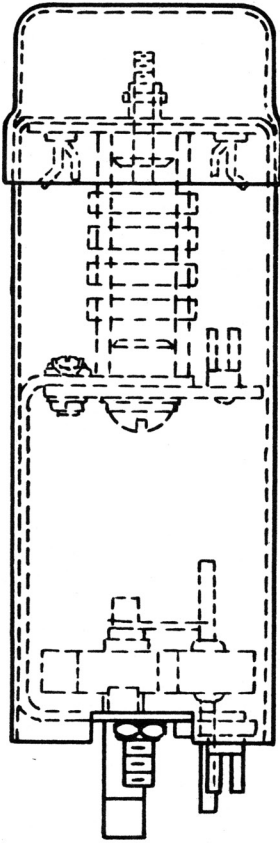

FIGURE 36k—WIRING DIAGRAM,  
BEAT FREQUENCY OSCILLATOR

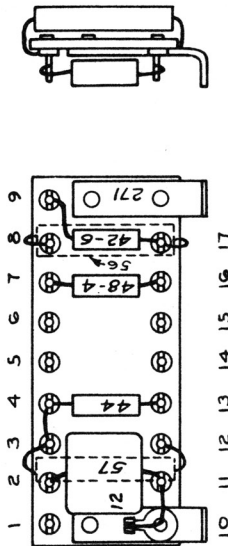
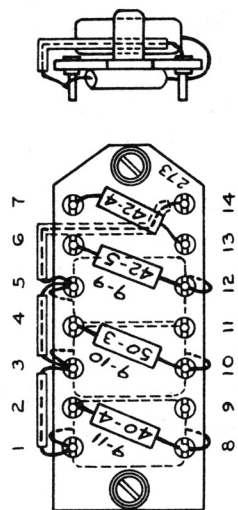
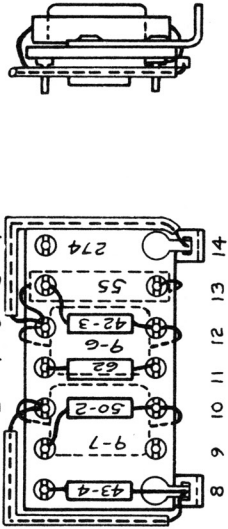
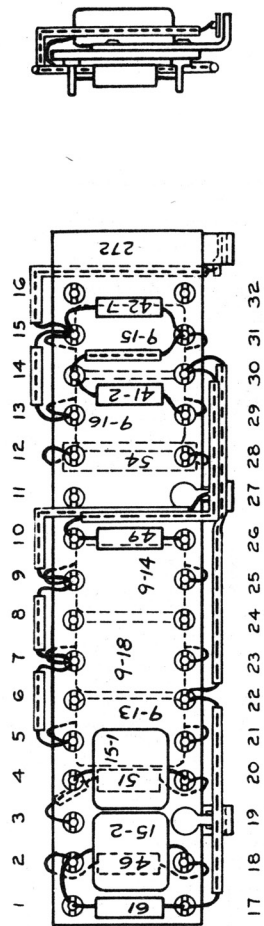

FIGURE 36L—RADIO RECEIVER BC-224-B:  
RESISTOR BOARDS WIRING DIAGRAM

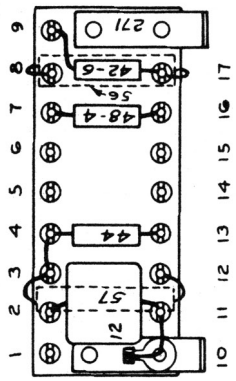
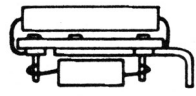
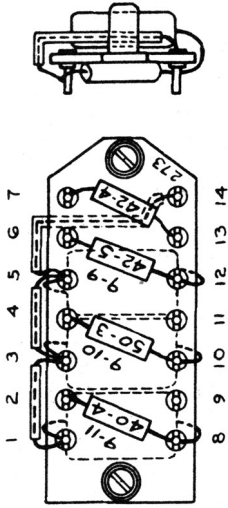
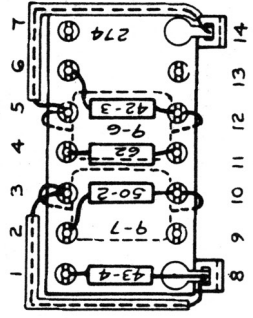
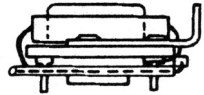
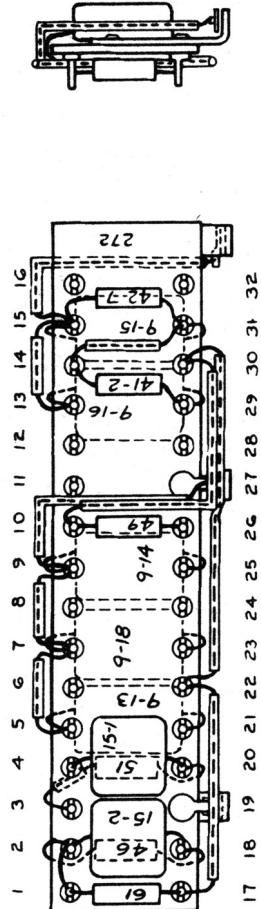

FIGURE 36M—RADIO RECEIVER BC-348-B:  
RESISTOR BOARDS WIRING DIAGRAM

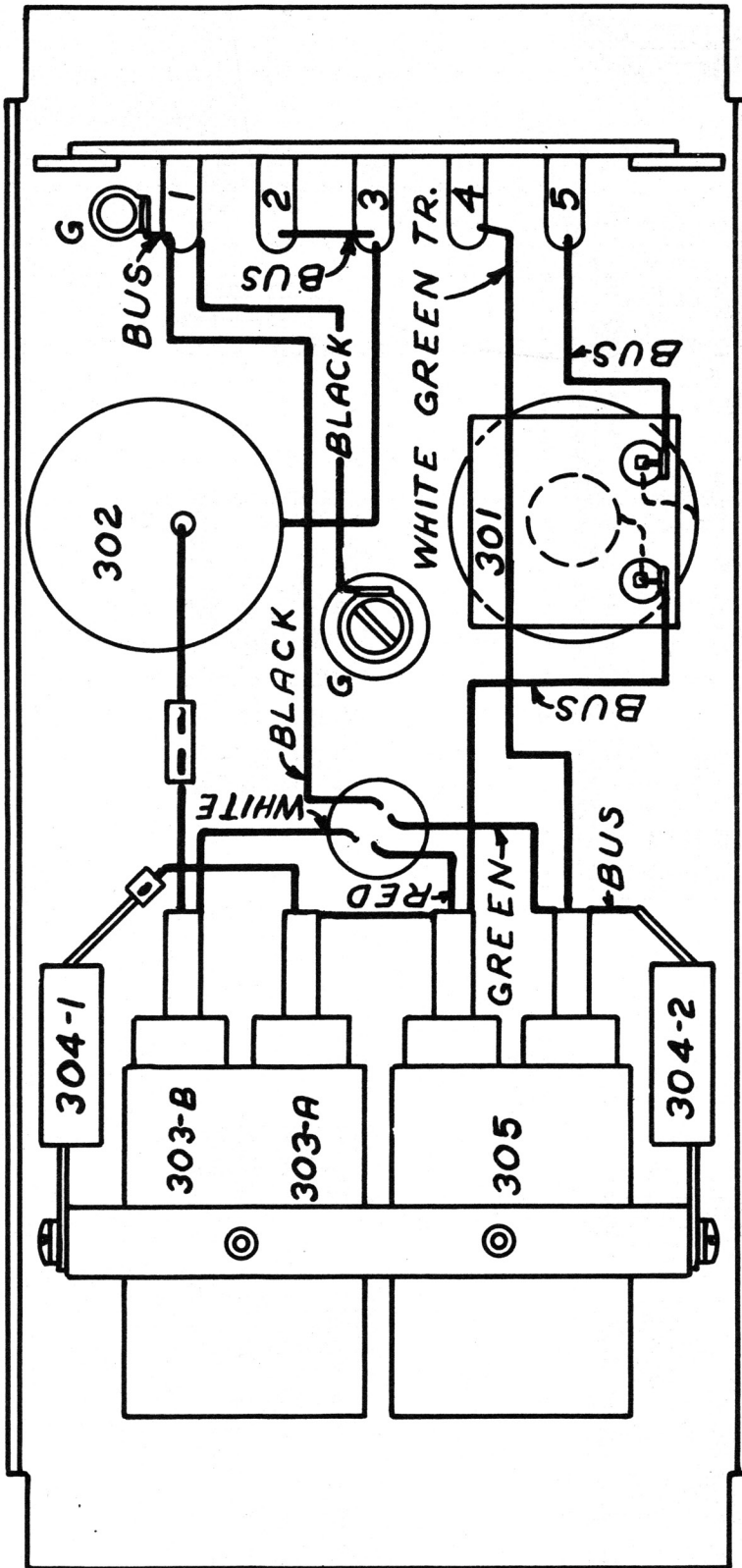

FIGURE 36N—WIRING DIAGRAM,  
DYNAMOTOR FILTER

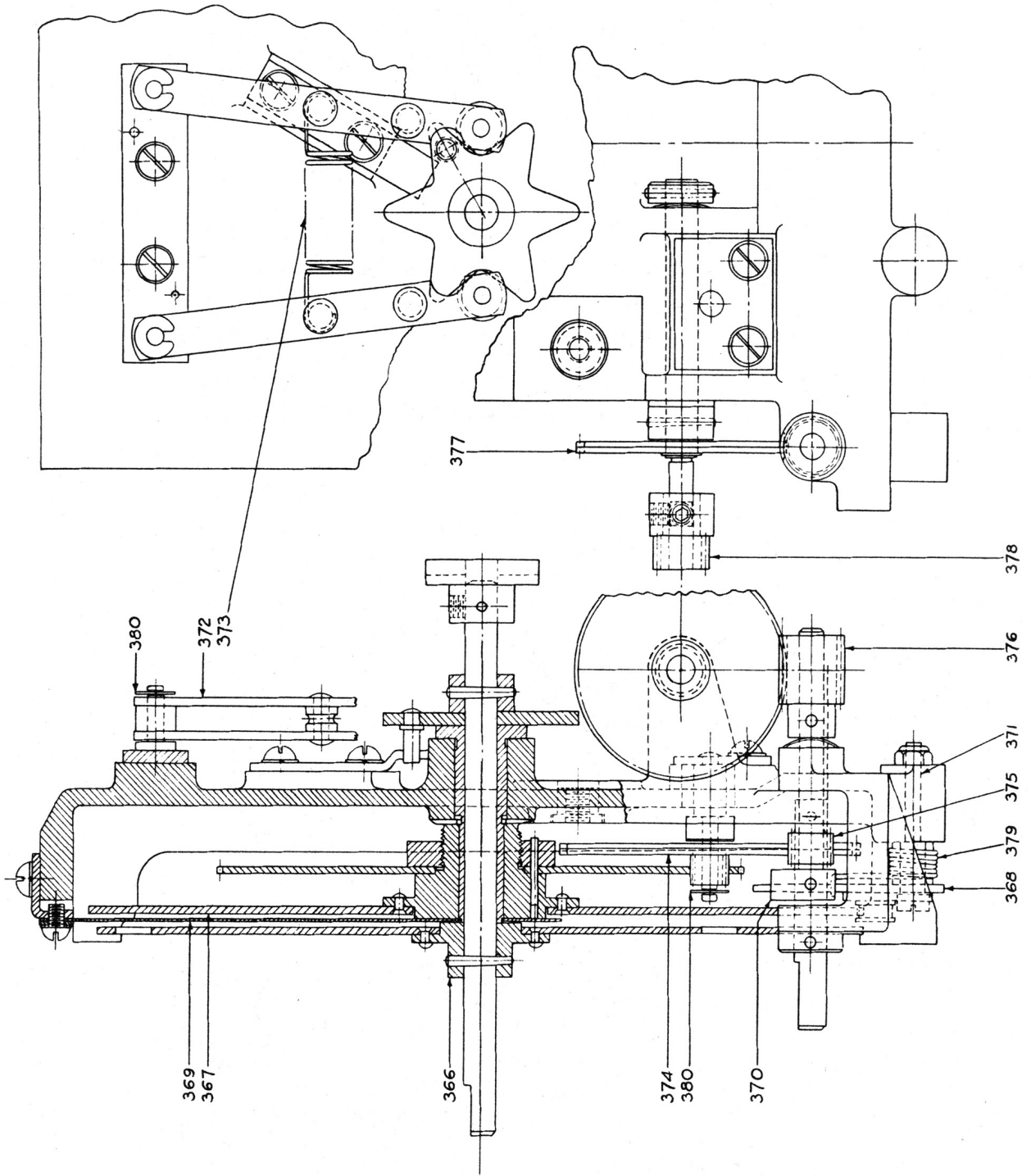

FIGURE 37—DIAL AND MASK ASSEMBLY



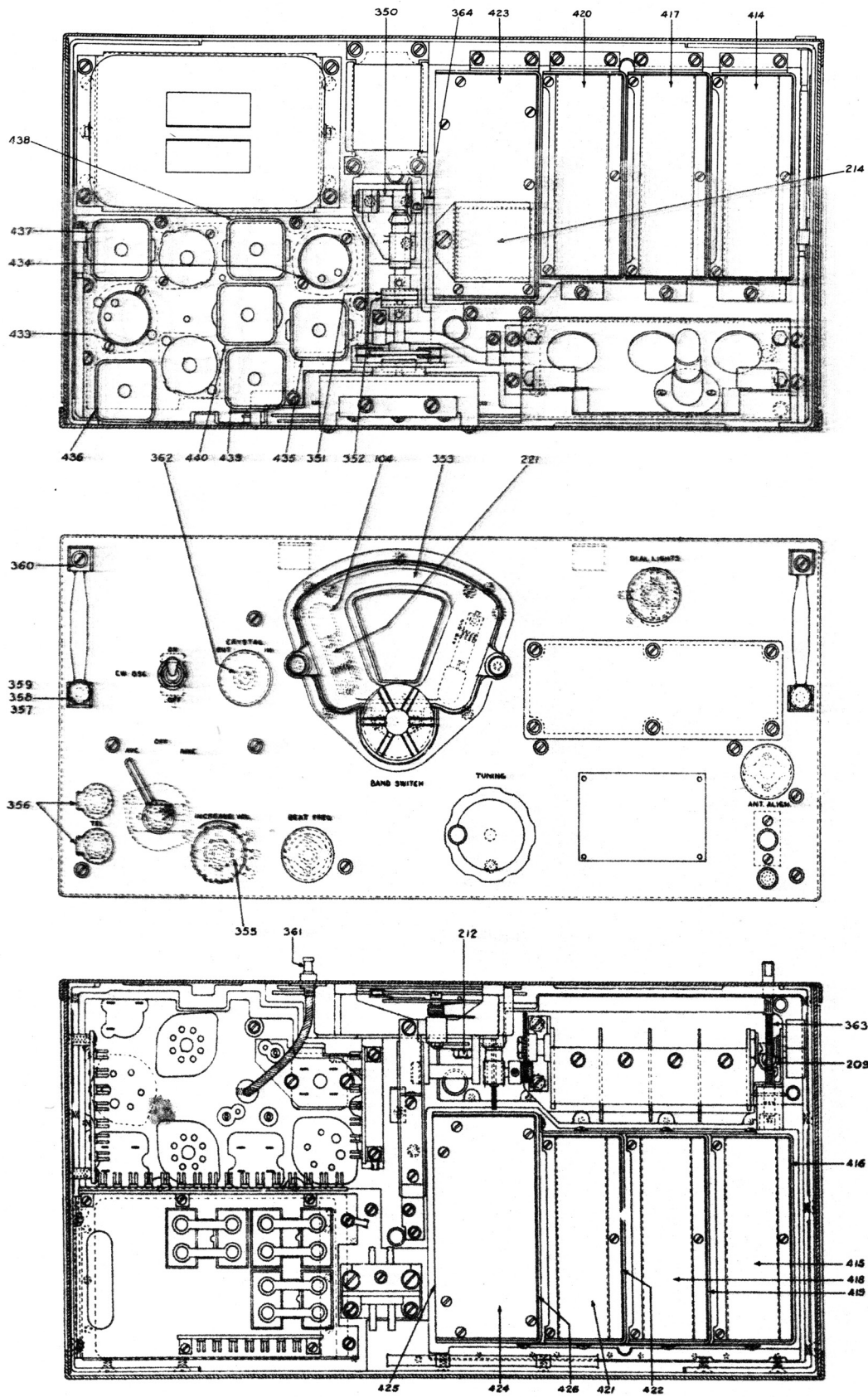

FIGURE 38—GENERAL VIEWS OF RADIO RECEIVERS BC-224-B AND BC-3488-B