

# TM 11-2617

TO 16-40-6

WAR DEPARTMENT TECHNICAL MANUAL

---

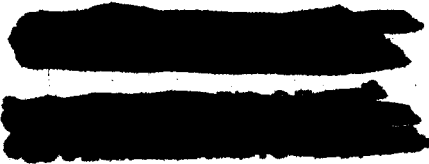

ANTENNA KIT  
FOR  
RHOMBIC TRANSMITTING  
ANTENNA  
(DRAWING ES-E-368-D)

---

WAR DEPARTMENT • 31 MARCH 1945

**WAR DEPARTMENT TECHNICAL MANUAL**

**TM 11-2617**

*This manual supersedes TM 11-2617, 24 October 1944*

---

**ANTENNA KIT  
FOR  
RHOMBIC TRANSMITTING  
ANTENNA  
(DRAWING ES-E-368-D)**



**WAR DEPARTMENT**

**31 MARCH 1945**

---

WAR DEPARTMENT,  
WASHINGTON 25, D. C., 31 MARCH 1945.

TM 11-2617, Antenna Kit for Rhombic Transmitting Antenna, is published for the information and guidance of all concerned.

[A. G. 300.7 (24 Apr 44).]

BY ORDER OF THE SECRETARY OF WAR:

G. C. MARSHALL,  
*Chief of Staff.*

OFFICIAL:

J. A. ULIO,  
*Major General,*  
*The Adjutant General.*

DISTRIBUTION:

AAF (5); AGF (5); ASF (2); T of Opn (5); Dept (5); Def Comd (2); Base Comd (5); AAF Comd (2); Arm & Sv Bd (2); S Div ASF (1); Tech Sv (2); SvC (5); Area ASvC (2); WDGS Lib (5); PC&S (2); PE (2); Dep 11 (2); Gen Overseas SOS Dep (Sig Sec) (2); GH (2); M Conc C (2); Air Base Hosp (2); Gen Sv Sch (5); Sp Sv Sch (10); USMA (10); ROTC (5); Lab 11 (2); Sig AS (2); Rep Shop 11 (2); A (5); D (2); AF (2). T/O & E: 11-107 (5); 11-127 (5); 11-237 (5); 11-287 (5); 11-587 (5); 11-592(5); 11-597 (5).

(For explanation of symbols see FM 21-6.)

# TABLE OF CONTENTS

	<i>Paragraph</i>	<i>Page</i>
<b>PART ONE. Introduction.</b>		
<b>SECTION I. Description.</b>		
General.....	1	1
Description of system.....	2	1
Frequency range.....	3	1
Packing information.....	4	1
<b>II. Installation.</b>		
General.....	5	2
Locating antenna.....	6	2
Antenna orientation.....	7	2
Ground elevations.....	8	2
Locating antenna poles.....	9	2
Locating transmission line poles.....	10	2
Locating anchors.....	11	2
Establishing plane of antenna curtain.....	12	3
Pole work.....	13	4
Anchors and guys.....	14	4
Antenna curtain.....	15	5
Fabrication of antenna curtain.....	16	6
Erection of antenna curtain.....	17	7
Transmission line.....	18	8
Dissipation line.....	19	9
<b>PART TWO. Operating instructions.</b>		
<b>PART THREE. Preventive maintenance.</b>		
<b>SECTION III. Preventive maintenance techniques.</b>		
Meaning of preventive maintenance.....	20	11
Description of preventive maintenance techniques.....	21	11
Itemized preventive maintenance.....	22	11
Common materials needed.....	23	11
Rhombic transmitting antenna.....	24	11
Preventive maintenance check list.....	25	11
<b>PART FOUR. Auxiliary equipment.</b>		
<b>PART FIVE. Repair instructions.</b>		
<b>SECTION IV. Theory.</b>		
<b>APPENDIX. Maintenance parts.</b>		
Maintenance parts for rhombic transmitting antenna.....	26	13

# LIST OF ILLUSTRATIONS

<i>Fig. No.</i>	<i>Title</i>	<i>Page</i>
1	Average ground elevation diagram.....	3
2	Strain insulators for line and curtain sides.....	5
3	Strain insulators for antenna curtain ends.....	5
4	Spreader insulator.....	5
5	Dissipation line insulator, exponential spreader.....	6
6	Transmission line insulator, support.....	6
7	Transmission line insulator, pole view.....	8
8	Dissipation line insulator, spacer.....	8
9	Dissipation line insulator, support.....	8
10	Horn gap insulator.....	9
11	Transmission line, down-lead view.....	17
12	Dissipation line, exponential portion.....	18
13	Dissipation line, terminating assembly.....	19
14	Wire sag data.....	20
15	Dead end and splice detail.....	21
16	Transmission line insulator assembly, dwg. ES-C-32574-A.....	22
17	Poly guy 75PX, dwg. ES-B-32500-A.....	23
18	Pole guy 75PXX, dwg. ES-B-32502-A.....	23
19	12-inch spreader insulator, dwg. SC-A-258-A.....	24
20	3-inch shackle, dwg. SC-A-274-D.....	24
21	Strain insulator, dwg. SC-A-286-D.....	24
22	Pole step data, dwg. SC-A-4007-A.....	24
23	Transmission line insulator, line supported, dwg. ES-A-19512-B.....	25
24	Transmission line insulator, line support, dwg. ES-A-19514-B.....	25
25	Strain insulator for 4-wire transmission line, dwg. ES-A-19517-A.....	25
26	Dissipation line pulley, dwg. ES-A-19518-A.....	25
27	Dissipation line pulley, dwg. ES-B-19519-A.....	26
28	Stand-off insulator, dwg. ES-A-19521-C.....	26
29	Strain insulator, dwg. ES-A-32534-A.....	26
30	Bowl insulator, dwg. ES-C-32552-B.....	27
31	Dissipation line insulator, line supported, dwg. ES-B-32573-B.....	27
32	Installation dwg. ES-E-368-D.....	29
32a	Installation dwg. ES-E-368-D (detachable).....	Rear Cover

## DESTRUCTION NOTICE

**WHY** — To prevent the enemy from using or salvaging this equipment for his benefit.

**WHEN** — When ordered by your commander.

- HOW** —
1. Smash — Use sledges, axes, handaxes, pickaxes, hammers, crowbars, heavy tools.
  2. Cut — Use axes, handaxes, machetes.
  3. Burn — Use gasoline, kerosene, oil, flame throwers, incendiary grenades.
  4. Explosives — Use firearms, grenades, TNT.
  5. Disposal — Bury in slit trenches, fox holes, other holes. Throw in streams. Scatter.

### USE ANYTHING IMMEDIATELY AVAILABLE FOR DESTRUCTION OF THIS EQUIPMENT.

- WHAT** —
1. Smash — All insulators and spacers.
  2. Cut — All antenna wires, guy wires, transmission lines, dissipation lines, down leads, and poles.
  3. Burn — All instruction manuals, poles, and wire.
  4. Bend — All anchor rods, ground rods, and braces.
  5. Bury or scatter — All remaining pieces of the above equipments including all connectors, bolts, nuts, and washers.

**DESTROY EVERYTHING**

---

## SAFETY NOTICE

**VOLTAGES ON THE ANTENNA AND TRANSMISSION LINE ARE HIGH ENOUGH TO ENDANGER LIFE AND MAY BE FATAL IF CONTACTED BY OPERATING PERSONNEL. MAKE CERTAIN THAT TRANSMITTER IS OFF WHEN MAKING ADJUSTMENTS.**

## PART ONE

# INTRODUCTION

### SECTION I. DESCRIPTION.

#### 1. GENERAL.

a. This technical manual covers the construction of a three-wire curtain rhombic transmitting antenna.

b. The purpose of the rhombic antenna is to direct radiation, thus providing a stronger signal in the desired direction of transmission.

#### 2. DESCRIPTION OF SYSTEM.

a. **Transmission Line.** The transmission line consists of two three-strand conductors spaced 12 inches apart, and has a characteristic impedance of 600 ohms.

b. **Antenna Curtain.** The antenna curtain (side wires) consists of three copperweld conductors. The three conductors are grouped at each end and are anchored to the front and rear poles. This multiple arrangement of the conductors lowers the characteristic impedance of the antenna, thereby making it possible to match the system to the 600-ohm transmission line.

c. **Dissipation Line.** The dissipation line consists of a down lead and modified exponential line. This dissipation line acts as a resistance dissipating the power arriving at the end of the antenna. A forced-perspective drawing of the line is shown in figure 12.

#### 3. FREQUENCY RANGE.

Seven sizes of antennas have been designed for operation over various distance ranges at frequencies of 4 to 22 megacycles. Basic information concerning the seven sizes of antennas is shown in table 1, figure 32. With the exception of the side wire length  $L$ , the tilt angle  $\theta$ , and the antenna height above ground  $H$ , all antennas have the same construction details.

#### 4. PACKING INFORMATION.

a. **Antenna Kit.** The antenna kit comes from the manufacturer packed in three boxes. The first box measures  $9\frac{1}{8} \times 24\frac{1}{8} \times 24\frac{1}{8}$  inches and weighs 171 pounds. Its volume is 3.1 cubic feet. The second box measures the same and weighs 178 pounds. The third box measures  $5\frac{1}{8} \times 23\frac{5}{8} \times 31\frac{1}{4}$  inches and weighs 144 pounds. Its volume is 2.2 cubic feet.

b. **Pole Guy Kit 75PX.** This pole guy kit comes packed in a box measuring 7 x 15 x 112 inches. Its volume is 6.8 cubic feet; its weight is 202 pounds.

c. **Pole Guy Kit 75PXX.** This pole guy kit comes packed in a box measuring 7 x 18 x 124 inches. Its volume is 9.04 cubic feet; its weight is 288 pounds.

d. **Transmission Line Kit.** The transmission line kit comes packed in two boxes and one bundle. One box measures  $8\frac{1}{8} \times 23\frac{5}{8} \times 23\frac{3}{4}$  inches and weighs 186 pounds. Its volume is 2.6 cubic feet. The second box measures  $15\frac{5}{8} \times 20\frac{3}{8} \times 34\frac{3}{4}$  inches and weighs 238 pounds. Its volume is 5.9 cubic feet. The bundle measures  $3\frac{1}{4} \times 3\frac{3}{4} \times 79$  inches and weighs 36 pounds. Its volume is 0.6 cubic feet.

e. **Dissipation Line Kit.** The dissipation line kit comes packed in one box and one bundle. The box measures  $5\frac{1}{4} \times 26 \times 30\frac{3}{4}$  inches and weighs 115 pounds. Its volume is 2.5 cubic feet. The bundle measures  $2\frac{1}{4} \times 2\frac{3}{4} \times 79$  inches and weighs 14 pounds. Its volume is 0.3 cubic feet.

**NOTE:** This packing information is applicable for Order No. 28719-Phila-44. The stock numbers are marked on the boxes.

## SECTION II. INSTALLATION.

### 5. GENERAL.

Data tables and detail drawings are furnished in this technical manual. The successful completion of an installation with the materials and equipment furnished depends on careful attention to the instructions. Certain illustrations in this manual are based on procurement drawings and can be used in the field for checking dimensions of components and for emergency manufacture of repair parts. Figure 32a is detachable and may be used as an original for making blueprint copies.

### 6. LOCATING ANTENNA.

a. If possible, locate the antenna on level or evenly sloping open ground. If the antenna must be situated on ground covered by woods or brush, clear out around and between pole sites to facilitate setting the poles and hanging the antenna curtain. In selecting a site for an antenna, avoid obstructions such as hills or buildings directly in front of and on the bearing line of the antenna. No obstruction in front of the antenna should be more than  $2^{\circ}$  or  $3^{\circ}$  above the horizontal plane of the antenna. This is approximately 200 or 300 feet at a distance of 1 mile from the antenna.

b. In general, construct the antennas as near the transmitter building as is practicable for any particular installation, and make the transmission line as short as possible. The usual procedure is to locate the antenna so that the transmission line runs directly from the rear of the antenna to the transmitter building.

### 7. ANTENNA ORIENTATION.

The bearing of an antenna, or its horizontal direction of transmission or reception, is given in degrees measured clockwise from true north. A line bearing true north and south must therefore be available before proceeding with the location of the antenna. The bearing of the antenna should be determined with an accuracy of plus or minus 15 minutes of arc.

### 8. GROUND ELEVATIONS.

Ground elevations at each antenna pole location stake must be obtained for use in determining the point above the ground for attaching the antenna harness. These elevations are also required to compute the position of the plane of the antenna curtain where the antenna must be located on uneven ground.

### 9. LOCATING ANTENNA POLES.

a. The location of the front and rear poles of the antenna should be determined by direct standard steel tape measurements along the major axis (bearing line) of the antenna. To determine the location of the side poles, locate a stake on the major axis at the midpoint of the antenna. Lay off perpendiculars each side of the base line from this midpoint, and then measure the correct distance to the side poles on the minor axis of the antenna. Pole-to-pole lengths and pole-to-pole widths are shown in table 1, figure 32.

b. Locate pole location stakes with an accuracy of plus or minus 0.2 foot. Measure all distances at least twice to make certain that the desired accuracy is obtained. Set four reference stakes around each antenna pole location, two on the antenna axis and two approximately at right angles to the axis. Set these stakes at a sufficient distance from the pole location to eliminate the possibility of being disturbed while the pole is being set.

c. Locate the dissipation line poles on the major axis of the antenna with locations and distances as shown in figure 32.

### 10. LOCATING TRANSMISSION LINE POLES.

Locate transmission line poles between the antenna and the transmitter building in as nearly a direct line as possible. Use a staggered spacing in locating these poles so that no two adjacent spans have the same length. Normally, use a 5-foot difference in spacing interval as follows: 100 feet, 105 feet, 95 feet, 100 feet, 95 feet, etc. Maximum span lengths should not exceed 105 feet.

### 11. LOCATING ANCHORS.

a. Be sure that anchor guys have at least a one-to-one lead; that is, the distance from the base of the pole to the upper end of the guy is the same or less than the horizontal distance from the base of the pole to the guy strand or to the axis thereof, depending upon the slope of the terrain. Set a stake to indicate the point where the anchor rod breaks the ground. Locate all antenna guys along the axis of the antenna.

b. Locate transmission line corner anchors, where required, on a line bisecting the interior angle on the outside of the corner to be guyed.



c. Locate the dissipation line anchor on the centerline of the dissipation line (at the weighted average). Anchor one end to the antenna end pole as shown in figure 32.

## 12. ESTABLISHING PLANE OF ANTENNA CURTAIN.

a. In many antenna locations the ground will be more or less uneven, and elevations taken at the antenna pole stakes may vary by several feet. Where elevation variations are less than 10 feet, the plane of the antenna should be made horizontal. Because the pole heights and points of harness attachments shown in table 1, figure 32, are for level ground, pole heights and points of harness attachment must be calculated for each pole of the proposed antenna, taking into account the ground elevation at the base of each pole.

b. Disregard the elevation at any pole where it is considerably greater or less than the others. Determine the average elevation by averaging the remaining three elevations, and provide a longer or shorter pole for the fourth location. With the above exception, the elevations at all four antenna pole stakes should be averaged, and the antenna erected so that its plane is a distance H above this average elevation.

c. Points of attachment of curtain harnesses may be calculated as indicated in the following example.

### EXAMPLE:

POLE	GROUND ELEVATION FRONT POLE = 0'	GROUND ELEVATION AVERAGE = 0'	POINTS OF HARNESS ATTACHMENT ABOVE GROUND
Front	0	-0.2	P+0.2
Right side	+3.4	+3.2	P-3.2
Left side	+2.6	+2.4	P-2.4
Rear	-5.2	-5.4	P+5.4
4/	+0.8 = 0.2	0.0	
Average	+0.2	0.0	

$$P = H + \frac{1}{2} \text{ Sag at } 90^\circ \text{ F.}$$

(See table 1, fig. 32).

d. The calculation of the various dimensions associated with the poles will be greatly facilitated if a diagram is drawn similar to that shown in figure 1. Make the diagram large enough so that all dimensions for each pole can be put on it directly. Required pole length = 1 ft + P + pole set  $\pm$  deviation of pole ground level from average ground level.

(+ if ground is low at the pole;  
- if ground is high at the pole).

e. In some cases, due to irregularity of ground conditions, reasonable doubt may exist as to the accuracy of the average ground level. It is then preferable to make the average antenna height a few feet greater than that obtained by computation.

f. In calculating new pole heights, provide approximately 1 foot of pole top above the harness attachments. Because only one guy per pole is

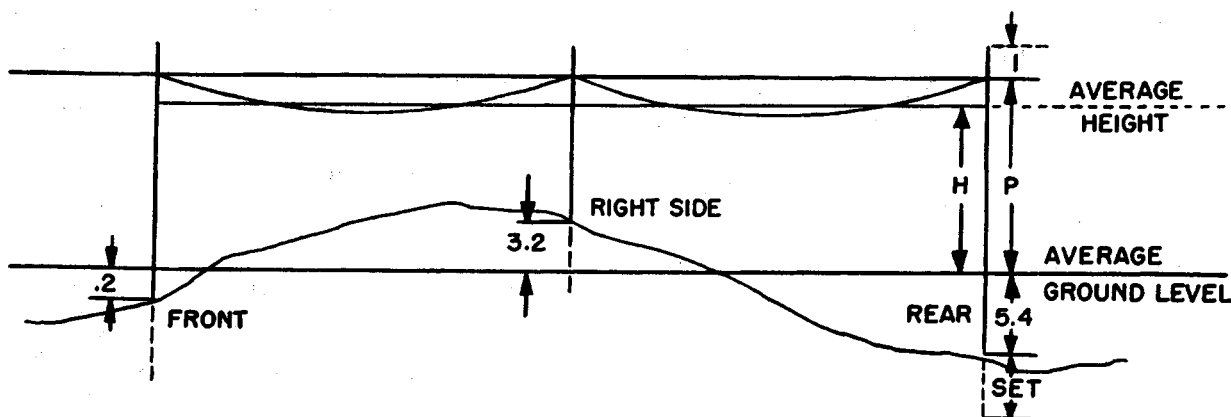

TL13451

Figure 1. Average ground elevation diagram.

used, set the antenna poles the full required depth indicated in table 2, figure 32. In no case should the depths of setting be reduced by more than 10 percent.

**g.** Where ground elevations at antenna pole stakes vary by more than 10 feet, the plane of the antenna may be tilted to take advantage of the ground slope. This applies only where the slope is consistent from front to rear, and extends for at least 1,000 yards in front of the antenna. In these cases make the front and rear poles approximately equal in height, to bring the major axis of the antenna parallel to the average ground slope. The minor axis of the antenna should be horizontal.

**h.** In order to design the antenna structure properly for sloping ground, contour lines of the area for a considerable distance must be available and allowances made for the characteristics of the terrain. It is advisable to locate the antenna on level ground, or on ground where the difference in average ground level from front to rear of the antenna is not more than 20 feet.

### 13. POLE WORK.

**a. Poles.** Creosoted pine or fir, butt-treated cedar, or poles of other woods obtained locally may be used. Poles should be class 2 or heavier.

**b. Stepping Poles.** Stagger  $\frac{5}{8}$ - by 10-inch spikehead pole steps 18 inches apart on opposite sides of the pole. This makes steps on the same side of the pole 36 inches apart. Drill guide holes  $\frac{1}{2}$  inch in diameter and 3 inches deep in creosoted pine poles before installing the steps. In Douglas fir and cedar poles (soft woods) drill  $\frac{3}{8}$ -inch diameter guide holes. All the boring work may be done on the ground before the poles are set. Use wood pole steps in place of spikehead pole steps for the first three steps at the ground end of pole. Install first step 36 inches from ground line. Install steps on the antenna poles parallel with the axis of the antenna. Figure 22 shows pole step data.

**c. Setting Antenna Poles.** (1) After the antenna pole has been dug to the required size and depth, set the pole and center it accurately in the hole. Use temporary guys to keep the antenna pole plumb while the hole is being backfilled and tamped.

(2) When raising the antenna pole and centering it in the hole, a gin pole approximately 5 feet longer than half the length of the poles to be set will be found convenient. The gin pole should have ade-

quate temporary guying in four directions, and may be raked toward the pole hole for ease in setting the antenna pole. Since a 90-foot pole may weigh 5,000 pounds, it is evident that pole setting operations must be carefully planned.

(3) Attach the permanent back guy and the temporary guying to the antenna pole before it is raised. Be sure that the bent thimble-eye eyebolt for the guy and the thimble-eye eyenut for the antenna harness are directly on the axis line of the antenna before the earth is backfilled around the pole.

**d. Setting Transmission Line Poles.** Set the transmission line poles, varying in height from 20 to 30 feet as required for grading, in accordance with standard pole line construction practices. Save time by attaching crossarms and fixtures to line poles before they are set. Set all poles to the full depths as required for individual pole lengths as indicated in table 2, figure 32.

### 14. ANCHORS AND GUYS.

**a. Installing Anchors.** (1) Expanding plate anchors have been specified for these antennas but alternate anchors of creosoted pine plank or logs, concrete blocks, or other local substitutes of sufficient holding power may be used.

(2) To install the expanding plate anchor, stake a hole at the anchor stake and extend it downward at an angle in line with the guy. Make the hole large enough to take the unexpanded or closed anchor and deep enough to accommodate the full length of anchor rod supplied. An earth auger and digging bar may be used on the small holes required for this type of anchor. After the anchor hole is dug, attach the anchor rod to the anchor and lower the assembly into the anchor hole. Expand the anchor into the undisturbed sides of the hole by pounding with a tamping bar or special expanding bar which fits around the anchor rod. Thoroughly tamp the earth used in backfilling the hole, especially at the bottom of the hole on top of the anchor.

**NOTE:** Steel towers (73-foot, 7 inches) complete with guys and anchors are available for all areas where reduction of shipping space is important. A steel pedestal base assembly is available for use in supporting the tower instead of concrete, and may be used where the soil will support 2,000 pounds per square foot.

**b. Guys.** (1) All antenna pole guys should be broken with strain insulators at 20-foot intervals with the first insulator approximately 4 feet from the eyebolt in the pole. The last section next

the ground may be longer than 20 feet but should not exceed 30 feet in length.

(2) Guys are furnished in kit sets. Two types are provided, the 75PX (10800 lbs.) used on side poles and the 75PXX (18000 lbs.) used on end poles. Both are factory assembled. Each type of guy uses strand, 3-bolt clamps each side of porcelain strain insulators at 20-foot intervals, a bent-eye eyebolt, curved washers, anchor, and anchor rod, as indicated in figures 17 and 18. This makes possible quick and easy attachment of guys to poles. Before installing the guys, check the tightness of the bolts in the guy clamps.

(3) Single guys, supporting the antenna curtain stress only, are generally supplied to be used on self supporting poles which have been set at proper depth in firm earth (table 2, fig. 32).

(4) Guys on transmission line and dissipation line poles do not require insulators. The guys consist of  $\frac{5}{16}$ -inch strand (6000 lbs.) with one 3-bolt clamp at each end together with an eyebolt, curved washers, anchor, and anchor rod (supplied with transmission and dissipation line kits).

(5) When guy kits are not available and guys have to be made up on location, they should be fabricated in a shop where the use of a vise and wrenches will enable a thorough tightening of the clamps on the enclosed strand. Use caution to prevent fracturing or shearing of bolts or stripping of threads.

(6) At locations where the nature of the soil is such that two anchors will be required for guys on

the front and rear antenna poles, the last insulated section may be made in the form of a bridle with the strand passing from one anchor through the porcelain strain insulator and back to the second anchor, with a clamp at the insulator.

(7) Properly tension all guys. This may be done using come-along-grips with a coffer hoist or block and tackle.

## 15. ANTENNA CURTAIN.

High strength, 40-percent conductance, 3-strand No. 12 AWG copperweld wire has been specified for the antenna. Its rated breaking load is 2,236 pounds. Other wire, such as No. 6 AWG (0.162), 40-percent conductance copperweld, may also be used.

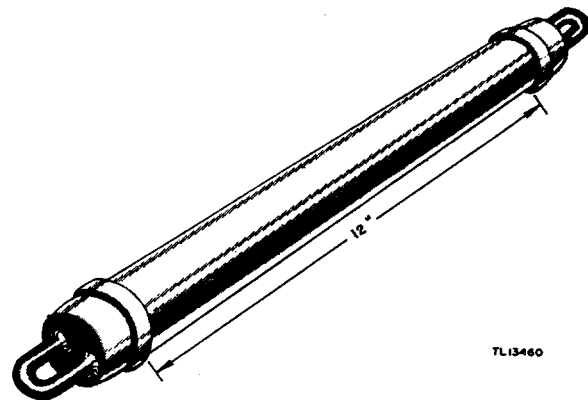

Figure 3. Strain insulator for antenna curtain ends.

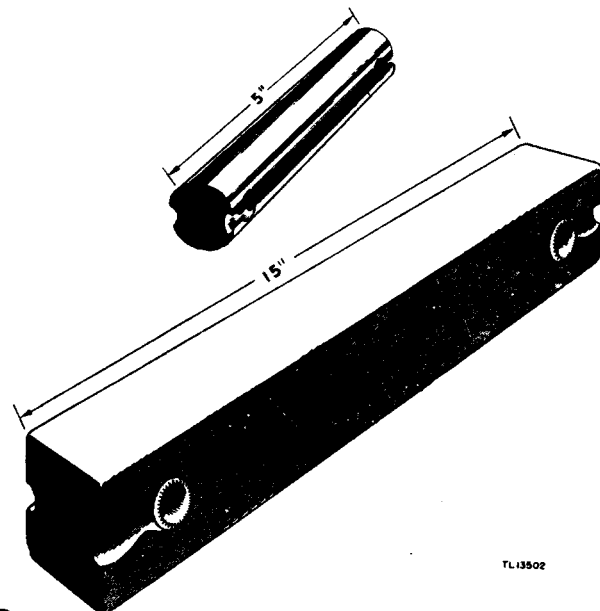

Figure 2. Strain insulators for line and curtain sides.

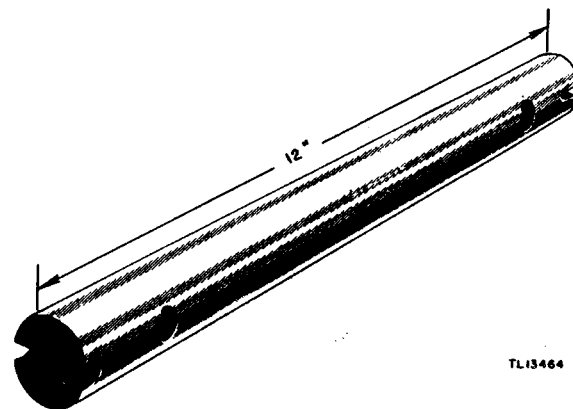
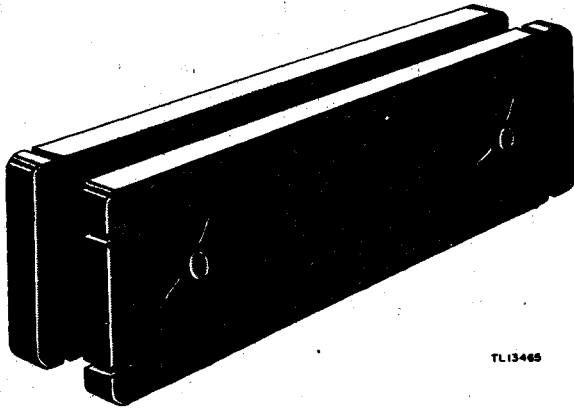

Figure 4. Spreader insulator.

a. In handling the copperweld wire, be careful not to nick or scratch the wire with pliers, sharp rocks, or climbing spurs. Nicks which penetrate through the outer shell of copper will expose the steel core to corrosion, which will in time reduce the strength of the wire. Be especially careful



TL13465

Figure 5. Dissipation line insulator, exponential spreader.

when handling the wire used in the antenna curtain. When soldering served joints, cover the joint with flux and hold it over a solder pot. Pour hot 50-50 solder over the serving until the entire

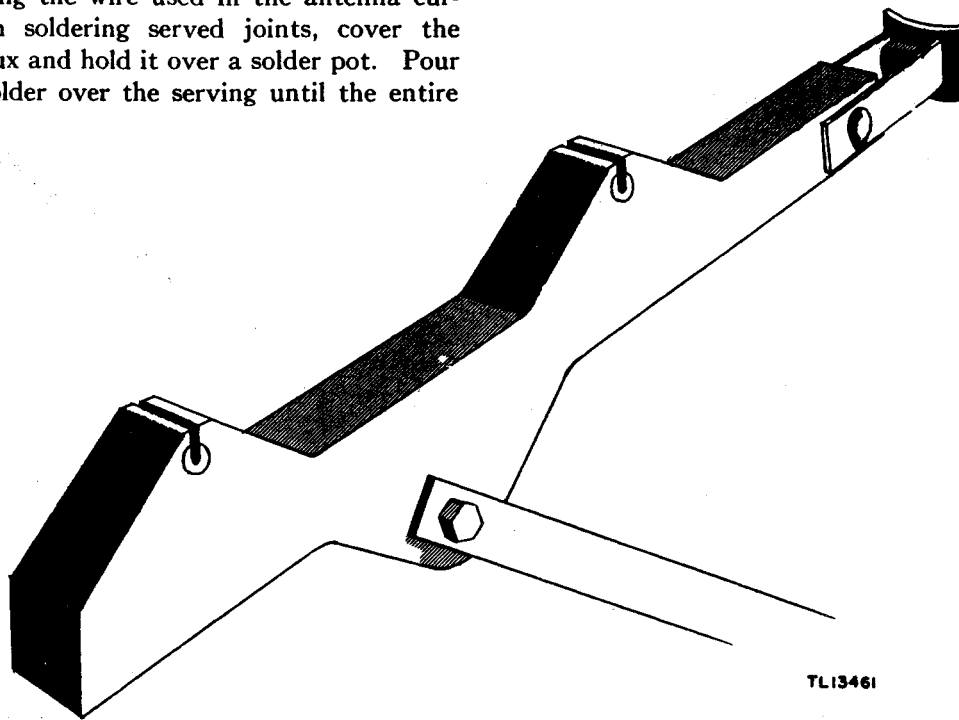

TL13461

Figure 6. Transmission line insulator, support.

assembly is heated and solder has penetrated to the center of the joint. The poured joint must be handled carefully until it has cooled and the solder becomes set. Although it is definitely not recommended, served joints may be soldered using the flame from a gasoline blowtorch. With this method use extreme care to keep the flame moving and to apply only sufficient heat to melt the solder into the joint. It is very easy to apply too much heat with an open flame, thereby annealing the copperweld wires and reducing their strength.

A large heavy duty soldering iron, well tinned, may be used.

**NOTE:** Three-strand No. 12 AWG copperweld 40 percent conductivity has a breaking strength of 2,236 pounds. When annealed by too much heat, the breaking strength is reduced more than 50 percent.

b. If the nature of the ground will permit, it is advisable to fabricate the antenna curtain at the location of the antenna. The antenna can then be raised into position (on the poles) directly from the ground. The poles provide convenient points for dead-ending the wires while they are measured under tension.

## 16. FABRICATION OF ANTENNA CURTAIN.

a. Measure from either the front or rear pole anchor, along the center line of the antenna, a distance equal to twice the side length (L) of the antenna specified, plus 5 feet. Drive a stake to mark this distance. Set up a wire payout reel at the anchor and pull out six copperweld antenna wires between the anchor and the stake. Three wires should pass on the left side of the antenna poles, and three wires on the right side.

b. Slide a single long-bar strain insulator (fig. 2) on each of these wires. Be sure that the glazed saddleway end of each insulator is placed on the wire.

c. To measure the wires of length L for the antenna, fasten an insulator (with the antenna wire attached) to an anchor. Attach at the opposite end a wire grip with a set of small blocks, and place the wire in tension. Place boxes or other supports under the wire so that it will be in as nearly a straight line as possible. The tension should be at least 200 pounds, and each wire should be measured under the same conditions of sag and tension.

d. Starting from the bearing point of the pole end of the insulator (fig. 3), measure off with a standard steel tape a distance equal to twice the side length (L) of the antenna specified, subtract the length of the insulator, and carefully mark the wire for the bearing point of the insulator. The wire length plus the length of the two insulators is to be 2 L. As an example, this measurement is 2 feet x 375 feet = 750 feet for antenna type A. Repeat the measurements to be sure of accuracy. Mark the point so that it will not be lost. Two pieces of friction tape, one each side of the mark, wrapped around each wire is one way of retaining the marks. Establish similar marks at the mid-point of each wire, to be used later in establishing the insulator locations at the side poles of the antenna. In every case attach the wire to the insulator so that the mark falls on the bearing point of the insulator.

e. Splice the transmission line down leads with the antenna leads. Set up two coils of 3-strand No. 12 AWG on two payout reels at the antenna rear end pole. Pull two wires out on the ground, each of sufficient length to allow erection of down leads.

f. Slide a long-bar strain insulator (fig. 2) on each of these wires. Be sure that the glazed saddleway end of each insulator is placed on the wire.

g. Insert one of the wires into each saddleway at opposite ends of a long-bar strain insulator used as a spreader (fig. 32, detail 7).

h. Splice the antenna curtain wires and the transmission line down lead to the metal-capped large strain insulator (fig. 3).

i. This same procedure is followed for the dissipation line down leads at the front end pole,

except that two down leads, each made up of two No. 14 AWG stainless steel wires are used instead of the 3-strand No. 12 copperweld.

j. Down lead connections are illustrated in fig. 32, detail 1. Be sure that the down lead hangs through the saddleway of the metal-capped large strain insulator.

k. Clean the group of seven wires (made up of three antenna dead ends doubled back and the down lead) so that they are bright, clean, free of grease, dirt, oxide, or sulphate. Form these wires into a tight and smooth group held by wire connectors as shown on figure 32, detail 1. Wrap (serve) the group tightly and smoothly with No. 18 AWG tinned copper wire between wire connectors, and solder the joint.

l. After antenna dead-end splices are completed, locate the bar insulator (fig. 2) used as a spreader 12 inches down from antenna in a level position, lash, and hold permanently in place with tie wires (fig. 32, detail 7). Use copperweld tie-wire on the transmission line and stainless steel tie-wire on the dissipation line.

m. Do not install the remaining regular insulator spreaders (fig. 4) until after the antenna wires have been erected, fastened, and sagged; and the down leads pulled reasonably taut.

## 17. ERECTION OF ANTENNA CURTAIN.

The following steps are suggested as a sequence of operation for erection of the antenna.

a. Lay each group of three curtain wires as straight as possible on the ground between the end poles. Shackle the end harness to the end insulators, and move the side insulators along the wires to their previously marked center location.

b. Using halyards or hand lines, hoist each end of the assembled curtain shackle to the eyenut on the pole. One end at a time may be raised. Avoid kinking or bending the antenna wires at any time.

c. Shackle the side harnesses to the side insulators, attach hand lines to the harnesses, and raise the antenna sides into position. With the antenna roughly positioned, check the anchors and guys to bring the poles to approximate vertical position.

d. Pull up the antenna to 3 feet from the center of the side poles and front pole, respectively, and 8 inches from the rear pole. The entire antenna

structure should now be approximately in position and the antenna sag should be roughly as specified. If the antenna does not fall reasonably into position with these preliminary adjustments, the difficulty should be found and remedied before accurate adjustment of sag is undertaken.

e. With the antenna approximately in position, locate a point on the side poles level with the antenna wire nearest the pole. At a distance below the point equal to the sag specified for the particular rhombic antenna being built and the prevailing atmospheric temperature, nail a lath horizontally on the pole so that it can be plainly seen from either end pole. Nail a lath similarly on each end pole so that it can be seen from each side pole. Adjust the saddle length to make the antenna wire dip to the line formed by two laths. The saddle lengths should be nearly 3 feet when the sag is correct. See figure 14 for sag data for antenna curtain.

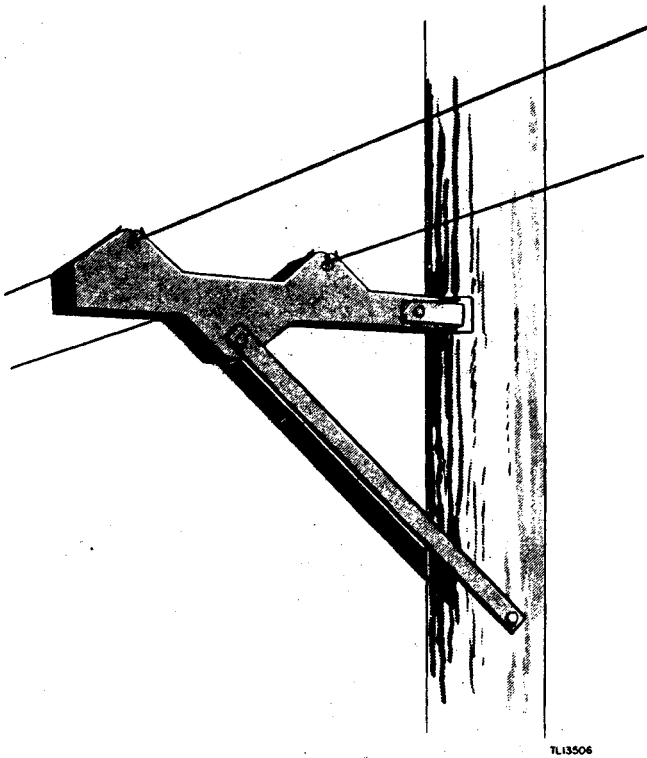

Figure 7. Transmission line insulator, pole view.

## 18. TRANSMISSION LINE.

a. The transmission line consists of two (3-strand No. 12 AWG copperweld) wires spaced 12 inches apart, has a characteristic impedance of 600 ohms, and connects the power output of the radio transmitter to the rhombic antenna. The down lead constitutes part of the transmission line, and the wire as furnished in rolls of specified length should require splicing at terminal ends only.

b. Shackle the large-bar strain insulators, which are already on the line wires, to the line end pole.

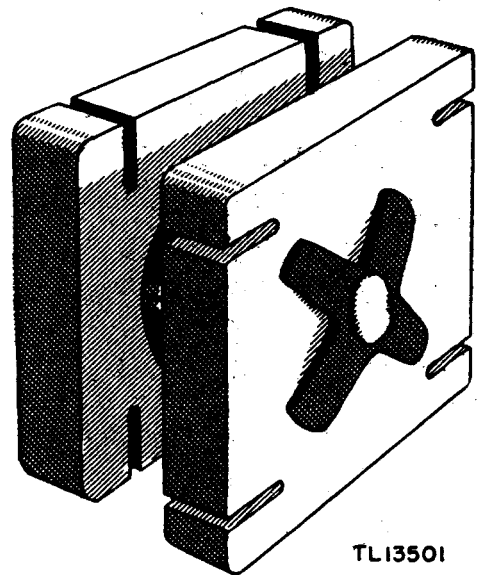

Figure 8. Dissipation line insulator, spacer.

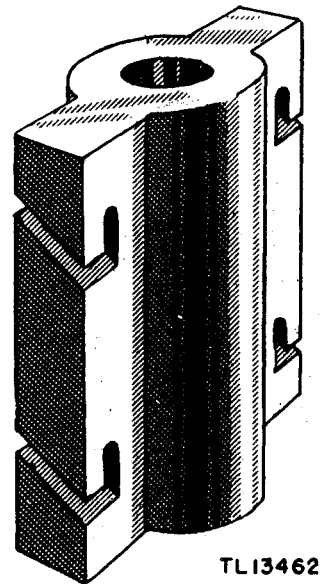

Figure 9. Dissipation line insulator, support.

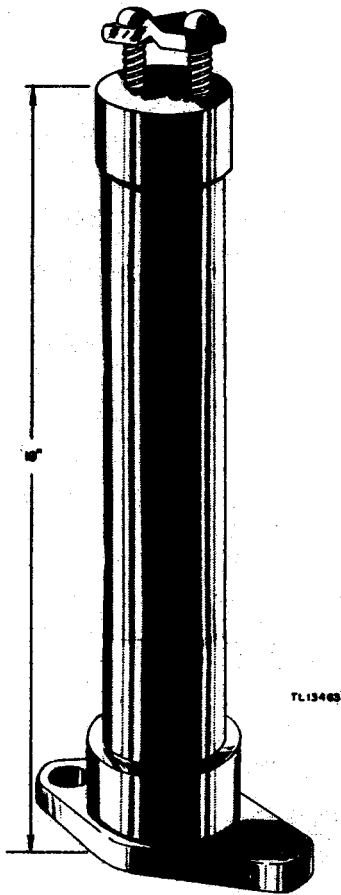

Figure 10. Horn gap insulator.

The line wires pass freely through the glazed saddleway of these insulators, thereby extending line tension to the down leads (fig. 11).

c. Support the line between the end poles using 2-wire line support insulators attached to intermediate poles (figs. 6 and 7). In most cases it will be found that the transmission line wires will stay in the slots of these insulators without being fastened. However, a short piece of wire may be inserted in the wire-retaining slot hole of the insulator with the ends bent upward  $\frac{1}{2}$  inch to keep the locking wire in place.

d. When line turns are required they should be made using the intermediate pole 2-wire line support insulator with its major axis bisecting the outside of the turn angle. Limit line turns to  $30^\circ$  line turn for any one pole (detail 6, fig. 32). Divide turns greater than  $30^\circ$  between two or more poles. Back guys are required on turns that exceed  $5^\circ$  and are led off the insulator side of the pole on an axis bisecting the outside of the turn angle.

e. Terminate the transmission line at the station

end in large bar-strain insulators shackled to a front-braced pole which also supports the horn gaps (detail 5, fig. 32). Sag the transmission line wires in accordance with the stringing sag and tension data shown in figure 14. Make the dead-end splice, and serve it together with a lead-in wire of suitable length to connect to the horn gap and to pass through the plastic bushings of the entrance bowl insulators into the transmitter building. Place a small quantity of Duco household cement (which may be obtained from station maintenance kit) on the line wires where they pass through the plastic bushings to make a water-tight seal. Mount the two entrance bowl insulators on a plywood mat so that their centers are spaced 12 inches apart (line spacing). For details of wire serving and splice see figure 15. Horn gap data is indicated on figure 32, note 5, detail 5. A horn gap insulator is shown in figure 10.

**NOTE:** Generally, it is less work to remove plywood mat from the building casing, mount the insulators, and reinstall the mat in the building casing.

## 19. DISSIPATION LINE.

a. The dissipation line is constructed of No. 14 AWG annealed stainless steel wire and includes the down lead, all in one length. The down lead portion is made up as a 2-wire line, (each wire, 2 strands No. 14 AWG stainless steel long lay twist) spaced 12 inches and has a characteristic impedance of approximately 650 ohms. The down lead becomes part of the horizontal portion of the dissipation line by a right-angle bend, and at this point a modified exponential line begins (fig. 12). The 2-wire down lead is transformed into a 4-wire dissipation line without the necessity of joining or splicing. The 12-inch spacing starts diminishing, the 2 strands (long lay twist) of each line wire now starts to become separate spaced lines, and in this manner in a line length of exactly 62.5 feet the 12 inches spacing tapers to 5.5 inches as the side members diverge to 1.3 inch at the dissipation line spreader insulator (fig. 5). From this point on, in a line length of an additional 62.5 feet, the 5.5-inch spacing tapers to 1.3 inches, while the side members remain spaced 1.3 inches apart. From this point, the line continues as a 1.3-inch square spaced 4-wire line. The modified exponential portion of the dissipation line transforms the approximately 650-ohm impedance of the down leads to approximately 200 ohms. The equally spaced 4-wire portion of the dissipation line is fundamentally two 400-ohm lines in parallel,

one of which is terminated open circuit (free, not connected to anything) and the other of which is terminated short circuit (ends connected diagonally) and grounded.

b. Shackle the large-bar strain insulators (fig. 2) which are already on the line wires, to the dissipation line pole under the down leads. The dissipation line wires pass freely through the glazed saddleway of these insulators, thereby extending line tension to the down leads. Twist together the two No. 14 stainless steel wires that make up each wire of the down leads in a "long lay twist" (one twist in about 5 feet length of wires) to keep the wires neatly together. String the four wires in exponential formation (fig. 32) to and through the first intermediate pole line support insulator (fig. 9) and in equal spaced formation (fig. 32) through the support insulators on the remaining intermediate poles. Temporarily terminate at the counterweight end pole. At this point, attach a temporary rigging to put equal tension of about 30 pounds, on each of the four wires. Install the dissipation line spreader insulator (fig. 5) as indicated in figure 32. Install the line supported spacer insulators (fig. 8) in the middle of the spans of the equally spaced portion of the dissipation line.

c. Measure off a distance of  $1\frac{1}{2}$  feet from the last line support insulator and mark this position accurately on each of the wires. Remove the

tension rigging. Insert the wires in the end strain insulators, (fig. 2) and fasten with wire connectors so that the marks are located accurately in corresponding positions of the end insulators. Allow at least 18 inches of tail wire on each wire of the diagonal pair, the bottom wire of which is next to the pole. Make up the harness sets for line tension and equalization, attach them to the remaining ends of the end insulators, and install them as indicated in figure 13. Install the counterweight assembly. With the line under normal tension, select the upper tail wire mentioned, bend it back directly to the diagonally opposite bottom wire, and seize both tail wires and fasten them together with wire connectors. Splice the ground wire to the tail wires a few inches below the line. Leave enough slack in the ground wire to allow for change in position with thermal changes in the line. Cut off the tail wires of the other diagonal pair of wires in the line about an inch beyond the connector. As shown in figure 32, install a 4-wire line spacer of the type used in the middle of spans (fig. 8) as close as possible to the end strain insulators.

**NOTE:** The dimensions of the exponential line portion of the dissipation line and spreader position are critical.

d. The pulleys are for equalization and tension of the dissipation line, and are shown in figures 26 and 27.

---

## PART TWO

# OPERATING INSTRUCTIONS

No specific operating instructions.



# PART THREE

## PREVENTIVE MAINTENANCE

### SECTION III. PREVENTIVE MAINTENANCE TECHNIQUES.

#### 20. MEANING OF PREVENTIVE MAINTENANCE.

Preventive maintenance is a systematic series of operations performed at regular intervals on equipment to eliminate major break-downs and unwanted interruption in service, and to keep the equipment operating at top efficiency. The prime function of preventive maintenance is to **prevent** break-downs, and therefore, the need for repair.

#### 21. DESCRIPTION OF PREVENTIVE MAINTENANCE TECHNIQUES.

**a. General.** This section of the manual contains specific instructions and serves as a guide for personnel assigned to perform maintenance operations. Usually six basic operations are performed. However, in this manual only three are used, namely: **Inspect, Tighten, and Clean.**

**b. Inspect.** Inspection in this manual consists of carefully observing all parts of the antenna, noticing especially the state of cleanliness.

**c. Tighten and Clean.** These two operations are self-explanatory. Be careful when tightening. Fittings tightened beyond the pressure for which they are designed will be damaged or broken.

#### 22. ITEMIZED PREVENTIVE MAINTENANCE.

Preventive maintenance on the rhombic transmitting antenna will be performed once a year. The equipment should be checked for satisfactory performance after each time maintenance work is performed.

#### 23. COMMON MATERIALS NEEDED.

The following materials will be needed in performing preventive maintenance:

Common hand tools (TE-41 or equivalent).

Clean cloth.

Solvent, Dry-cleaning, Federal Specification P-S-661a.

**NOTE:** Leaded gasoline will not be recommended as a cleaning fluid for any purpose. Solvent, Dry-cleaning, Federal Specification P-S-661a, is available, as cleaning fluid, through established supply channels. Oil, Fuel, Diesel, U. S. Army Specification 2-102B, may be used for cleaning purposes when dry-cleaning solvent is not at hand. Since unleaded gasoline is available only in limited quantities, and only in certain locations, it should be used for cleaning purposes only when no other agent is suitable.

#### 24. RHOMBIC TRANSMITTING ANTENNA.

**a. Inspect.** Inspect the antenna and transmission and dissipation lines for cleanliness of insulators and looseness of connections. Inspect pole guys for proper tension.

**b. Tighten.** All loose connections and loose guys.

**c. Clean.** Using a clean cloth and dry-cleaning solvent, clean the antenna and transmission and dissipation line insulators.

#### 25. PREVENTIVE MAINTENANCE CHECK LIST.

The following check list is a summary of the preventive maintenance operations to be performed on the rhombic transmitting antenna. The time interval shown on the check list may be reduced at any time by the local commander. However, for best performance of the equipment, it is recommended that the operations be performed at least as frequently as called for in the check list. The echelon column indicates which operations are first echelon maintenance and which operations are second echelon maintenance.

Item No.	Operations	Item	When performed							Echelon
			Before operation	After operation	Daily	Weekly	Monthly	Semi-annually	Yearly	
1	ITC	Antenna							X	1st
	F Feel	I Inspect	T Tighten	C Clean	A Adjust	L Lubricate				

**PART FOUR**  
**AUXILIARY EQUIPMENT**

Not used.

---

**PART FIVE**  
**REPAIR INSTRUCTIONS**

**SECTION IV. THEORY.**

See TM 11-455, Radio Fundamentals, and TM 11-314, Antennas and Antenna Systems.

---

## APPENDIX

# MAINTENANCE PARTS

### 26. MAINTENANCE PARTS FOR RHOMBIC TRANSMITTING ANTENNA.

The following information was compiled on 27 March 1945. The appropriate section of the ASF Signal Supply Catalog for Antenna Kit for Rhombic Transmitting Antenna (Drawing ES-E-368-D) is:

#### SIG 10-450, Antenna Kit for Rhombic Transmitting Antenna (Drawing ES-E-368-D), when published.

For the latest index of available catalog sections, see ASF Signal Supply Catalog SIG 2.

Ref symbol (fig. 32)	Signal Corps stock No.	Name of part and description	Quan. Issued per unit
	2A1624	<b>ANTENNA KIT</b>	
1	1A807.12	WIRE: (3 strands No. 12 AWG) copperweld; 40% cond; high strength.	5000 ft.
2	1A115	WIRE: $\frac{5}{16}$ " messenger; GS; (6,000 lb.).	30 ft.
3	1A90	WIRE: $\frac{3}{8}$ " messenger; GS; (10,800 lb).	15 ft.
4	1A116	WIRE: $\frac{7}{16}$ " messenger; GS; (18,000 lb).	10 ft.
5	1A818.1	WIRE: No. 18 AWG; copper; tinned; soft drawn, for serving.	1 lb.
6	3G1300-300	INSULATOR: strain; 12"; (dwg. ES-A-32534-A).	5 (1)
7	3G1100-192	INSULATOR: strain; 12"; (dwg. SC-A-286-D).	8 (1)
8	3G1250-192.3	INSULATOR: spreader; 12"; (dwg. SC-A-258-A).	4 (2)
9	5B1510-16	BOLT: machine; $\frac{5}{8}$ " x 16"; GI with nut.	4
10	5B4305	EYE NUT: thimble eye; GI; for $\frac{5}{8}$ " bolt; (Hubbard No. 7510, or equal).	5 (1)
11	5B20310	WASHER: curved; GI; for $\frac{5}{8}$ " bolt; (Hubbard No. 7822, or equal).	9 (1)
12	5B3449	CLAMP: guy; 3-bolt; medium; GI; (Hubbard No. 7449, or equal).	13 (1)
13	5B3461	CLAMP: guy; 3-bolt; heavy; GI; (Hubbard No. 7461, or equal).	9 (1)
14	5B18043	THIMBLE: steel; galv; $\frac{3}{8}$ " rope; (Hubbard No. 7593, or equal).	6 (1)
15	5B18044	THIMBLE: steel; galv; $\frac{1}{2}$ " rope; (Hubbard No. 7594, or equal).	2 (1)
16	5B4209	CONNECTOR: solderless; Reliable No. 1F.	16 (4)
	2A1624-4	<b>POLE GUY KIT 75PX</b>	
3	1A90	WIRE: $\frac{3}{8}$ "; messenger; GS; (10,800 lb).	117 ft. Approx.
13	5B3461	CLAMP: guy; 3-bolt; heavy; GI; (Hubbard No. 7461, or equal).	12
17	5B1442-16	BOLT: bent eye; $\frac{3}{4}$ " x 16"; GI; (Hubbard No. 6116, or equal).	1
18	5B4306	EYENUT; thimble eye; GI; for $\frac{3}{4}$ " bolt; (Hubbard No. 7511, or equal).	1
19	5B20312	WASHER: curved; GI; for $\frac{3}{4}$ " bent eye bolt; (Hubbard No. 7823, or equal).	1
20	5B20212-13	WASHER: square; 3" x 3"; $\frac{13}{16}$ " hole; GI; for A rod; (Hubbard No. 7817).	1
21	5B109	ANCHOR: (A-H-9); 4-way expanding; 15" diam. open.	1
22	5B707A	ANCHOR ROD: (AH-7A); $\frac{3}{4}$ " x 9'; GI; (Hubbard No. 8429, or equal).	1
23	3G1875-504	INSULATOR: ball; strain; (Thomas No. 504, or equal).	5
24	5B17504	PLATE: curved lift; GI; for $\frac{3}{4}$ " bent eye bolt; (Hubbard No. 8888, or equal).	1

Quantities shown in parenthesis are spares included in the basic quantities.

26. MAINTENANCE PARTS FOR RHOMBIC TRANSMITTING ANTENNA (contd).

Ref symbol (fig. 32)	Signal Corps stock No.	Name of part and description	Quan. Issued per unit
25	5B10008-4.5	SCREW: lag; GI; 1/2" x 4 1/2".	1
26	5B17137	STEP: pole; 5/8" x 10"; GI; (Hubbard No. 7125, or equal).	38
27	5A3710	STEP: pole; wood; (dwg. SC-A-4007-A).	3
28	6L1460	SPIKE: gauge No. 2; 6" long; (for upper nail fastening, wood step).	3
29	6L1430	SPIKE: gauge No. 5; 4 1/2" long; (for lower nail fastening, wood step).	3
	2A1624-3	<b>POLE GUY KIT 75PXX</b>	
4	1A116	WIRE: 7/16"; messenger; GS; (18,000 lb).	125 ft. Approx.
13	5B3461	CLAMP: guy; 3-bolt; heavy; GI; (Hubbard No. 7461, or equal).	24
30	5B1316-16	BOLT: bent eye; 1" x 16"; GI; (Hubbard No. 6196, or equal).	1
31	5B4308	EYENUT: thimble eye; GI; for 1" bolt; (Hubbard No. 7512, or equal).	1
32	5B20316	WASHER: curved; GI; for 1" bent eyebolt; (Hubbard No. 7824, or equal).	1
33	5B20077	WASHER: square; 4" x 4"; 1 3/16" hole; GI; (Hubbard No. 7820, or equal).	1
34	5B110	ANCHOR: (AH-10); 4-way expanding; 19" diam open.	1
35	5B708A	ANCHOR ROD: (AH-8-A); 1" x 10'; GI; (Hubbard No. 8440, or equal).	1
36	3G1875-506	INSULATOR: ball; strain; (Thomas No. 506, or equal).	5
37	2A1624-2/P1	PLATE: curved lift; GI; for 1" bent eyebolt; (Hubbard No. 8899, or equal).	1
25	5B10008-4.5	SCREW: lag; GI; 1/2" x 4 1/2".	2
26	5B17137	STEP: pole; 5/8" x 10"; GI; (Hubbard No. 7125, or equal).	38
27	5A3710	STEP: pole; wood; (dwg. SC-A-4007-A).	3
28	6L1460	SPIKE: gauge No. 2; 6" long; (for upper nail fastening, wood step).	3
29	6L1430	SPIKE: gauge No. 5; 4 1/2" long; (for lower nail fastening, wood step).	3
	2A1624-2	<b>TRANSMISSION LINE KIT</b>	
1	1A807.12	WIRE: (3 strands No. 12); copperweld; 40% cond; high strength.	1300 ft.
2	1A115	WIRE: 5/16" messenger; GS; (6,000 lb).	100 ft.
38	1A806	WIRE: No. 6 AWG; copper; hard-drawn; for horn gap.	10 ft.
7	3G1100-192	INSULATOR: strain; 12" (dwg. SC-A-286-D).	9 (1)
39	3G1350-88	INSULATOR: stand off; (dwg. ES-A-19521-C); 10".	4 (1)
40	3G1050-128	INSULATOR: entrance bowl; including mounting hardware; (dwg. ES-C-32552-B).	3 (1)
41	3G1350-103	INSULATOR ASSEMBLY: transmission-line support; 2-wire spaced 12"; including mounting hardware; (dwg. ES-C-32574-A).	6
42	2A1624-2/S1	SHACKLE: forged steel; galvanized; for strain insulator; (dwg. SC-A-274-D).	5 (1)
43	5A1601.5	CROSS ARM: wood; douglas fir; 3 1/4" x 4 1/4" x 18".	2
44	5B1309-12.1	BOLT: oval eye; 5/8" x 12"; GI; (Hubard No. 39962, or equal).	2
45	5B1308-8	BOLT: oval eye; 1/2" x 8"; GI; (Hubbard No. 39938, or equal).	9 (1)
9	5B1510-16	BOLT: machine; 5/8" x 16"; GI; with nut.	1

Quantities shown in parenthesis are spares included in the basic quantities.

26. MAINTENANCE PARTS FOR RHOMBIC TRANSMITTING ANTENNA (contd).

Ref symbol (fig. 32)	Signal Corps stock No.	Name of part and description	Quan. Issued per unit
46	5B1505-5.5	BOLT: machine; $\frac{5}{16}$ " x $5\frac{1}{2}$ "; GI; with nut.	6
25	5B10008-4.5	SCREW: lag; GI; $\frac{1}{2}$ " x $4\frac{1}{2}$ ".	3
11	5B20310	WASHER: curved; GI; for $\frac{5}{8}$ " bolt; (Hubbard No. 7822, or equal).	3
47	5B20209-11	WASHER: square; $2\frac{1}{4}$ " x $2\frac{1}{4}$ "; $\frac{11}{16}$ " hole; GI; (Hubbard No. 7813, or equal).	3 (1)
48	6L58026Z	WASHER: round; $\frac{3}{8}$ " hole; $\frac{7}{8}$ " OD; GI.	6
49	5B20109	WASHER: round, $\frac{9}{16}$ " hole; $1\frac{3}{8}$ " OD; GI; (Hubbard No. 7803, or equal).	18 (2)
50	5B20111	WASHER: round; $\frac{11}{16}$ " hole; $1\frac{3}{4}$ " OD; GI; (Hubbard No. 7805, or equal).	2 (1)
12	5B3449	CLAMP: guy; 3-bolt; medium; GI; (Hubbard No. 7449, or equal).	8
51	5B101	ANCHOR: (AH-1); 8" cone-shaped.	4
52	5B704	ANCHOR ROD: (AH-4); $\frac{5}{8}$ " x 6'; Spec 71-68.	4
53	5B4426	GROUND ROD: (GP-26); $\frac{1}{2}$ " x 6'; GI.	1
54	5B17001.5	STAPLE: $1\frac{1}{2}$ " long; $\frac{3}{16}$ " spread; galv; (Hubbard No. 7200, or equal).	36
14	5B18043	THIMBLE: steel; galv; $\frac{3}{8}$ " rope; (Hubbard No. 7593, or equal).	6 (1)
55	5B5283.5	HOOK: guy; J; (Hubbard No. 7583 $\frac{1}{2}$ , or equal).	3
	2A1624-1	<b>DISSIPATION LINE KIT</b>	
1	1A807.12	WIRE: (3 strands No. 12); copperweld; 40% cond; high strength.	25 ft.
2	1A115	WIRE: $\frac{5}{16}$ "; messenger; GS; (6,000 lb).	40 ft.
56	1A814.13	WIRE: No. 14 AWG; stainless steel; fully annealed.	1500 ft.
57	1A706	WIRE: flexible wire tiller rope; galv $\frac{3}{16}$ ", (Perko or equal).	12 ft.
58	1A708	WIRE: flexible wire tiller rope, galv $\frac{1}{4}$ ", (Perko or equal).	12 ft.
7	3G1100-192	INSULATOR: strain; 12"; (dwg. SC-A-286-D).	4 (1)
59	3G1250-80.5	INSULATOR: strain; 4"; $\frac{3}{4}$ " diam; (dwg. ES-A-19517-A).	5 (1)
8	3G1250-192.3	INSULATOR: spreader; 12"; (dwg. SC-A-258-A).	4 (1)
60	3G1350-76	INSULATOR: line support; 4-wire spaced 1.3"; (dwg. ES-A-19514-B).	4 (1)
61	3G1350-77	INSULATOR: spacer; 4-wire spaced 1.3"; (dwg. ES-A-19512-B).	4 (1)
62	3G1150-99	INSULATOR: spacer; 4-wire spaced rectangular; 5.5" and 1.3"; (dwg. ES-B-32573-B).	2 (1)
42	2A1624-2/S1	SHACKLE: forged steel; galv; for strain insulator; (dwg. SC-A-274-D).	3 (1)
43	5A1601.5	CROSS ARM: wood; douglas fir; $3\frac{1}{4}$ " x $4\frac{1}{4}$ " x 18".	1
44	5B1309-12.1	BOLT: oval eye; $\frac{5}{8}$ " x 12"; GI; (Hubbard No. 39962, or equal).	2
45	5B1308-8	BOLT: oval eye; $\frac{1}{2}$ " x 8"; GI; (Hubbard No. 39938, or equal).	2
11	5B20310	WASHER: curved; GI; for $\frac{5}{8}$ " bolt; (Hubbard No. 7822, or equal).	3
47	5B20209-11	WASHER: square; $2\frac{1}{4}$ " x $2\frac{1}{4}$ "; $\frac{11}{16}$ " hole; GI; (Hubbard No. 7813, or equal).	1
63	5B20080	WASHER: round; $\frac{7}{16}$ " hole; 1" OD; $\frac{5}{64}$ " thick; (Hubbard No. 7801, or equal).	8 (2)
49	5B20109	WASHER: round; $\frac{9}{16}$ " hole; $1\frac{3}{8}$ " OD; (Hubbard No. 7803, or equal).	6 (2)
25	5B10008-4.5	SCREW: lag; $\frac{1}{2}$ " x $4\frac{1}{2}$ ".	1

Quantities shown in parenthesis are spares included in the basic quantities.

26. MAINTENANCE PARTS FOR RHOMBIC TRANSMITTING ANTENNA (contd).

Ref symbol (fig. 32)	Signal Corps stock No.	Name of part and description	Quan. Issued per unit
64	5B10006-6A	SCREW: lag; GI; $\frac{3}{8}$ " x 6".	3
12	5B3449	CLAMP: guy; 3-bolt; medium; GI; (Hubbard No. 7449, or equal).	3
10	5B4305	EYENUT: thimble eye; GI; for $\frac{5}{8}$ " bolt; (Hubbard No. 7510, or equal).	1
51	5B101	ANCHOR: (AH-1); 8" cone-shaped.	1
52	5B704	ANCHOR ROD: (AH-4); $\frac{5}{8}$ " x 6'; Spec 71-68.	1
53	5B4426	GROUND ROD: (GP-26); $\frac{1}{2}$ " x 6'; GI.	1
54	5B17001.5	STAPLE: $1\frac{1}{2}$ " long; $\frac{3}{16}$ " spread; galvanized; (Hubbard No. 7200, or equal).	36
55	5B5283.5	HOOK: guy; J; (Hubbard No. 7583 $\frac{1}{2}$ , or equal).	1
65	6R7449	PULLEY: sheave; for line tension equalization; (dwg. ES-A-19518-A).	3
66	6R7449-1	PULLEY: sheave; for line tension; (dwg. ES-B-19519-A).	1
67	5B4103	CLIP: wire rope; $\frac{3}{16}$ "; GS; (U-W, GE Co, or equal).	12
68	5B4104	CLIP: wire rope; $\frac{1}{4}$ "; GS; (Hubbard No. 7480, or equal).	4
69	5B4105	CLIP: wire rope; $\frac{5}{16}$ "; GS; (Hubbard No. 7481, or equal).	6
14	5B18043	THIMBLE: steel; galvanized; $\frac{3}{8}$ " rope; (Hubbard No. 7593, or equal).	4
16	5B4209	CONNECTOR: wire; (Reliable No. 1F, or equal).	9 (3)
70	6Z3185	CONNECTOR: wire; (Reliable No. 109, or equal).	12 (2)
74	5B4222	CONNECTOR: wire; (Reliable No. 4F with bar spacer, or equal).	3 (1)

Quantities shown in parenthesis are spares included in the basic quantities.

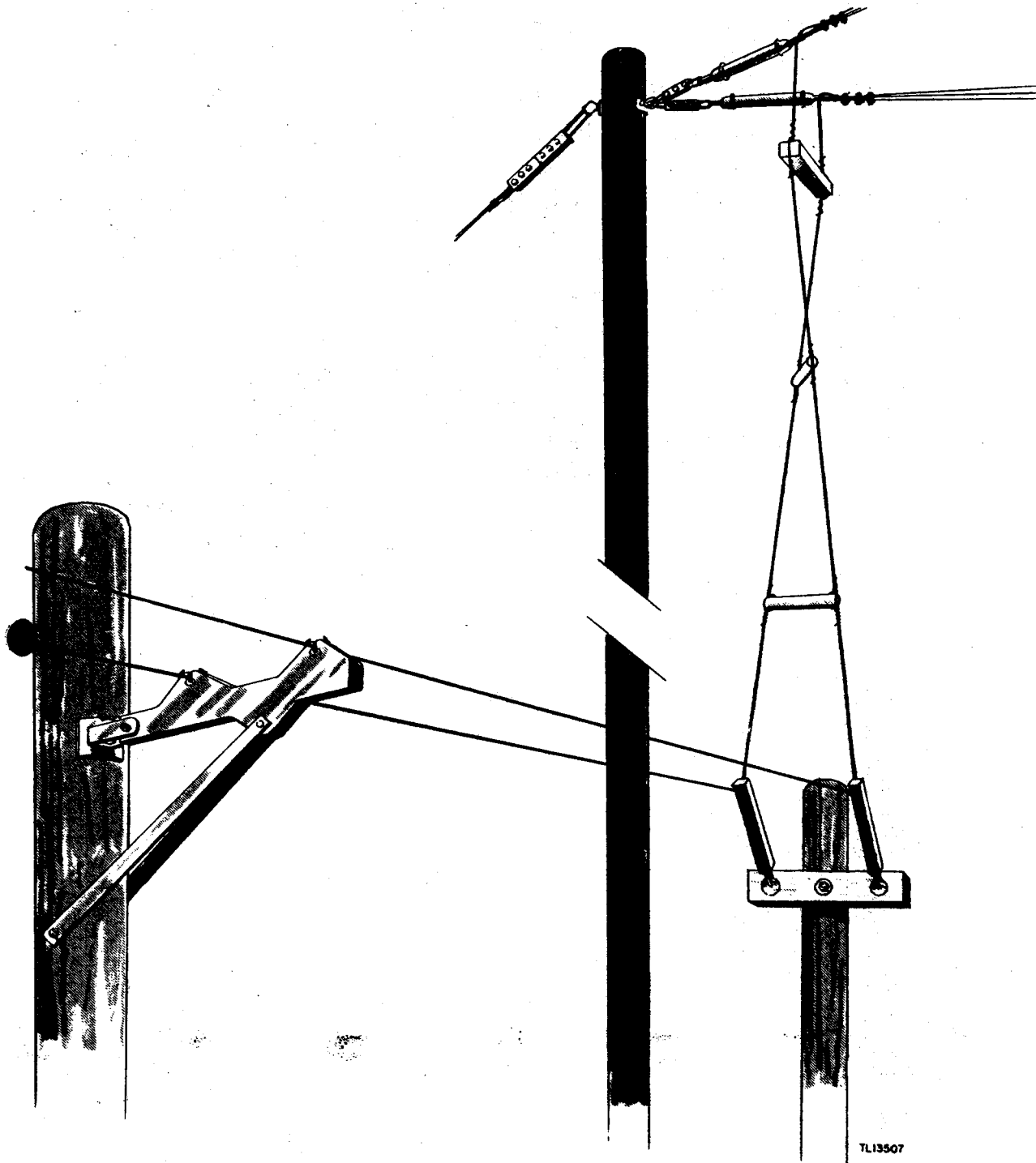

TL13507

*Figure 11. Transmission line, down-lead view.*

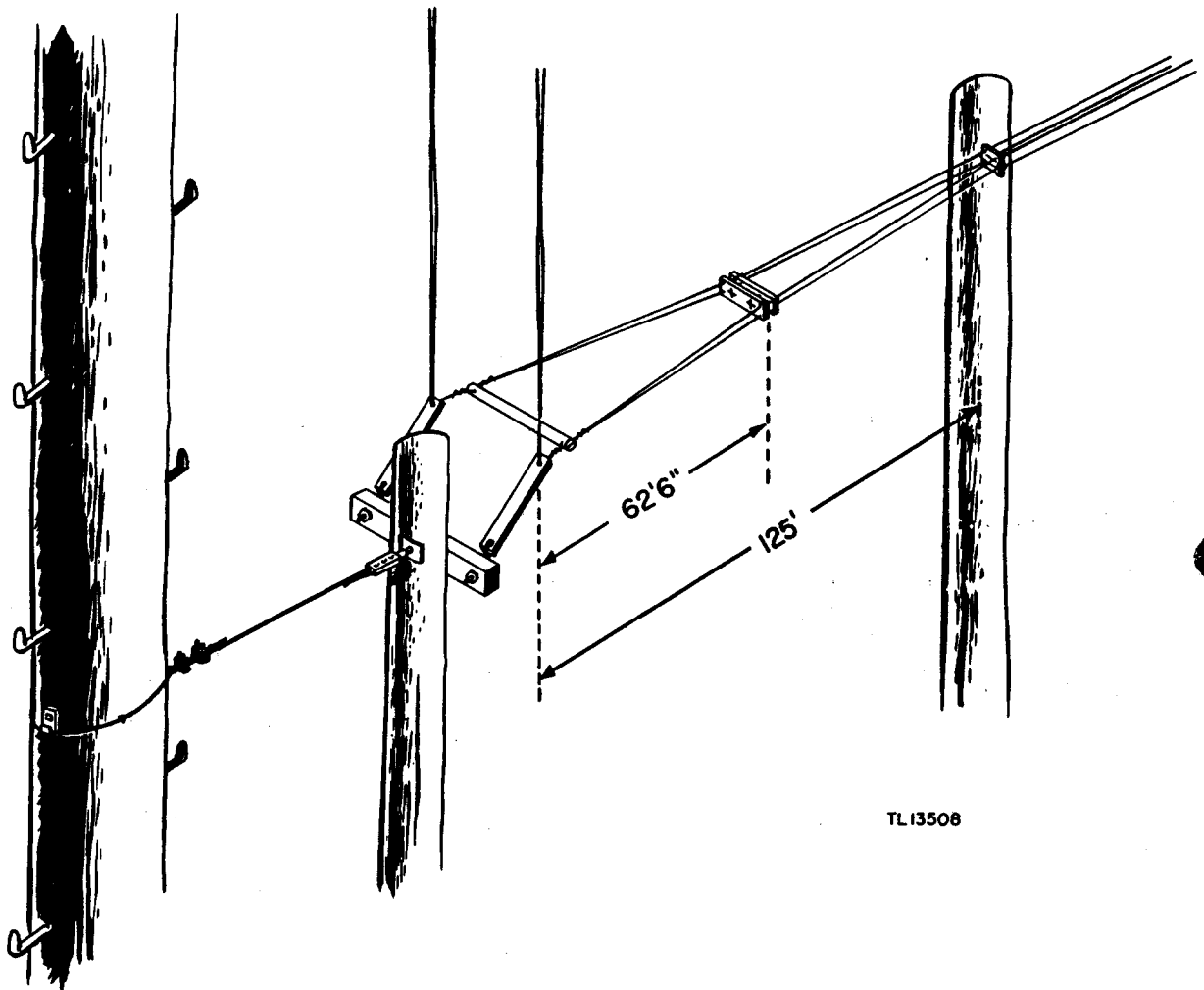

TL 13508

Figure 12. Dissipation line, exponential portion.



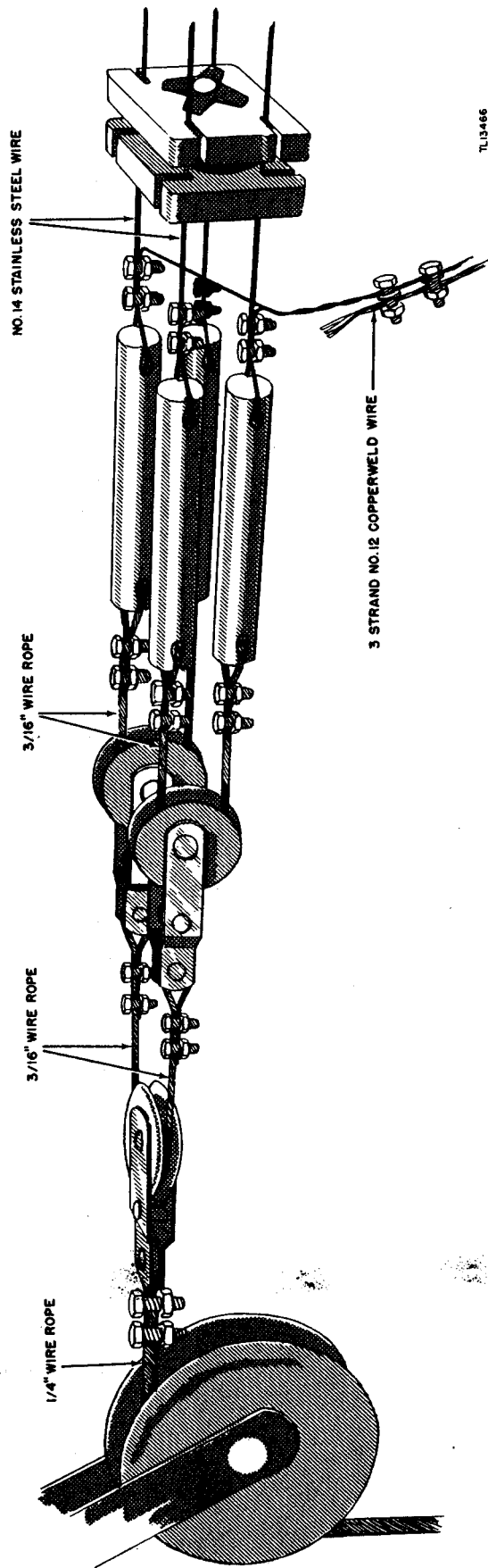
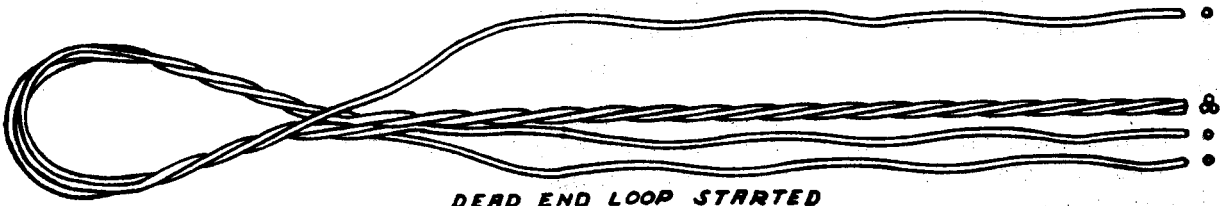

Figure 13. Dissipation line, terminating assembly.

SPAN IN FEET	SAG IN INCHES			TENSION IN POUNDS		
	<u>Span</u>	<u>30°F</u>	<u>60°F</u>	<u>90°F</u>	<u>30°F</u>	<u>60°F</u>
100	2.3	2.8	3.8	362	288	216
125	3.6	4.5	5.9	360	288	218
150	5.1	6.4	8.4	358	288	221
175	7.1	8.7	11.4	357	288	223
200	9.3	11.4	14.7	355	288	226
225	11.7	14.5	18.1	353	288	228
245	13.9	17.1	21.3	352	288	230
250	14.6	17.9	22.2	352	288	231
270	17.2	20.8	25.9	350	288	233
275	17.8	21.6	26.8	350	288	233
290	19.8	24.0	29.6	349	288	235
300	21.1	25.6	31.4	349	288	236
315	23.4	28.3	34.3	348	288	237
325	24.9	30.1	36.4	347	288	238
350	29.2	35.0	42.0	345	288	241
375	33.8	40.3	48.0	344	288	243
400	38.5	45.6	53.8	342	288	246
425	44.0	51.5	60.0	340	288	248
450	49.7	57.8	67.2	338	288	250
475	55.8	64.5	74.5	335	288	251
500	62.2	71.4	81.8	332	288	252

NOTE: THE ABOVE TABLES ARE BASED ON A 60°F. STRINGING TENSION OF 288 LBS., 12.8% OF THE RATED BREAKING STRENGTH OF THE CONDUCTOR.

STRINGING SAG AND TENSION DATA COPPERWELD CONDUCTOR 3 STRANDS, #12, 40% CONDUCTIVITY			ISSUE
DATA <i>A.A.R.</i>	CK. <i>A.A.R.</i>	APPROVED <i>[Signature]</i>	
DR. <i>A.A.R.</i>	VERIFIED <i>7E</i>	DATE <i>9-10-43</i>	
O. C. SIG. O. U.S. ARMY PLANT ENGINEERING AGENCY PHILA. PA.		ES-A-19529-	<i>A</i>



DEAD END LOOP STARTED

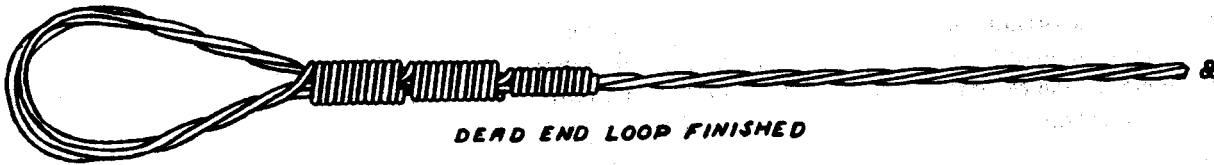

DEAD END LOOP FINISHED

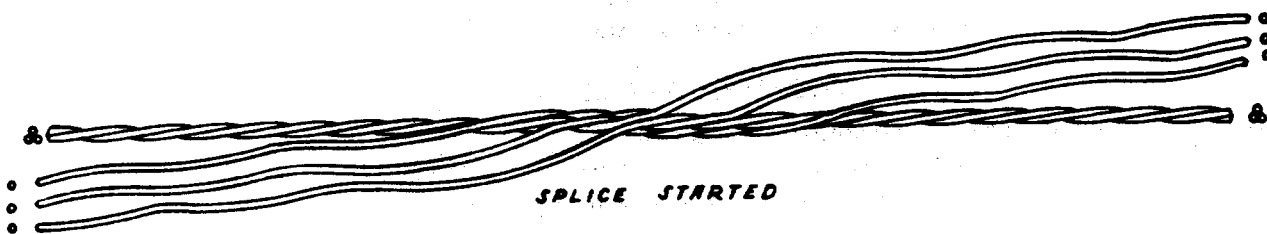

SPLICE STARTED



SPLICE FINISHED

- NOTES:
- 1-POUR SOLDER OVER SERVE  
DO NOT USE BLOW TORCH.
  - 2-EACH INDIVIDUAL WIRE SERVING  
OF GROUP - 12 TURNS EACH.

TL 13458

SPLICE AND DEAD END DETAILS FOR STRANDED COPPERWELD			ISSUE
DATA <i>A.A.R.</i>	CK. <i>A.A.R.</i>	APPROVED <i>JVI</i>	
DR. <i>A.A.R.</i>	VERIFIED <i>FE</i>	DATE - <i>5/18-43</i>	
O.C. SIG. O. U.S. ARMY PLANT ENGINEERING AGENCY PHILA. PA.		<i>ES-A-19352-</i>	<i>A</i>

Figure 15. Dead end and splice detail.

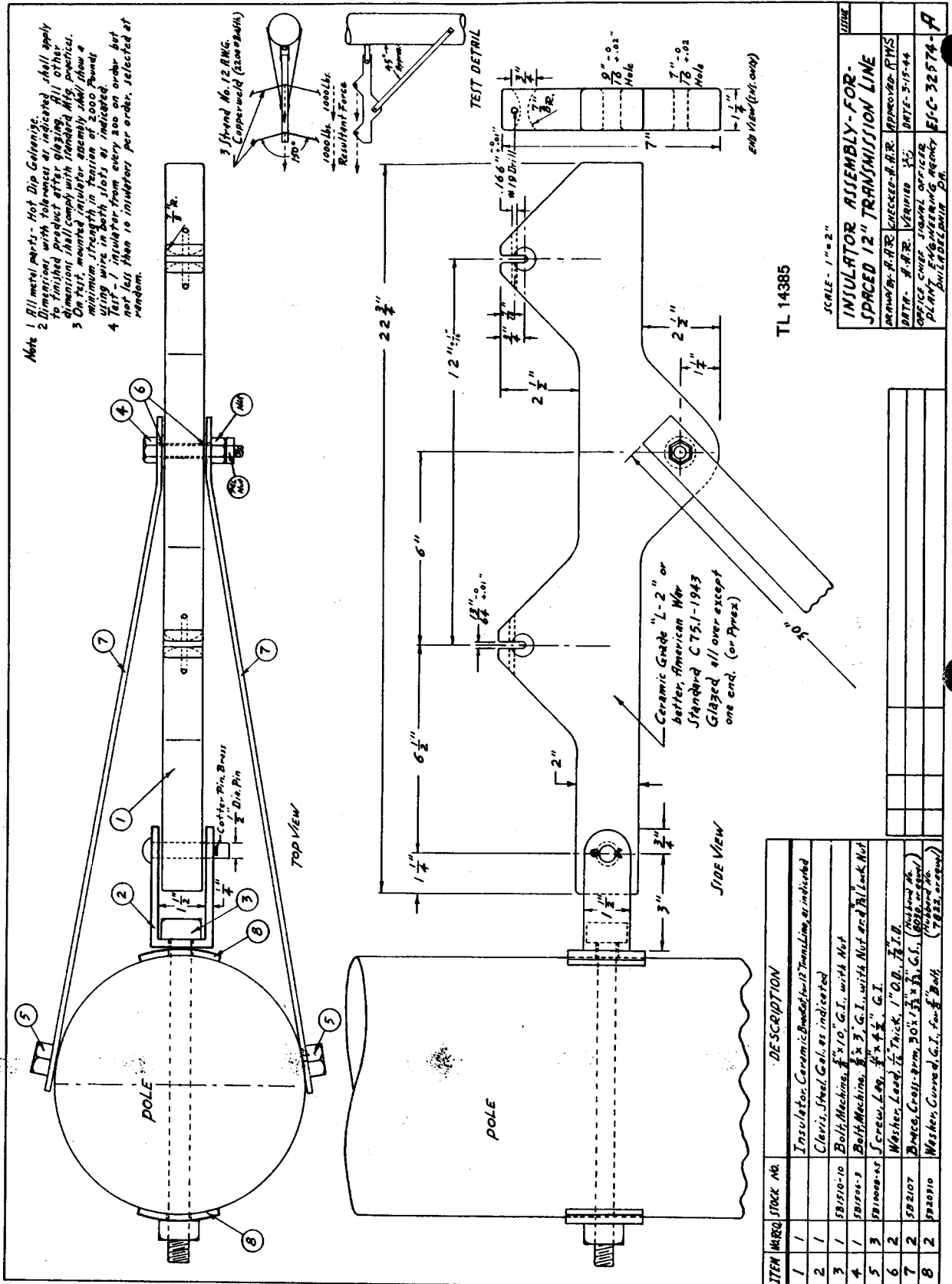

Figure 16. Transmission line insulator assembly, dwg. ES-C-32574-A.

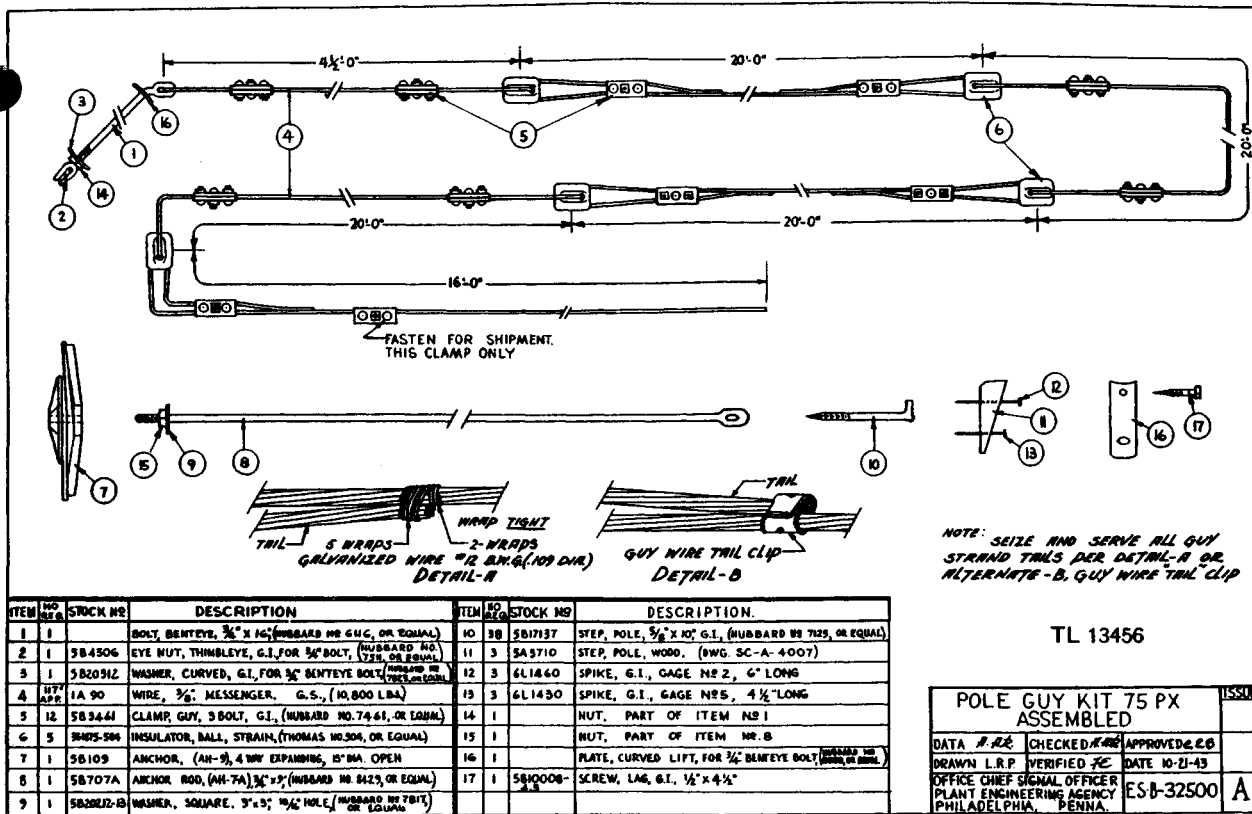

Figure 17. Pole guy 75PX, dwg. ES-B-32500-A.

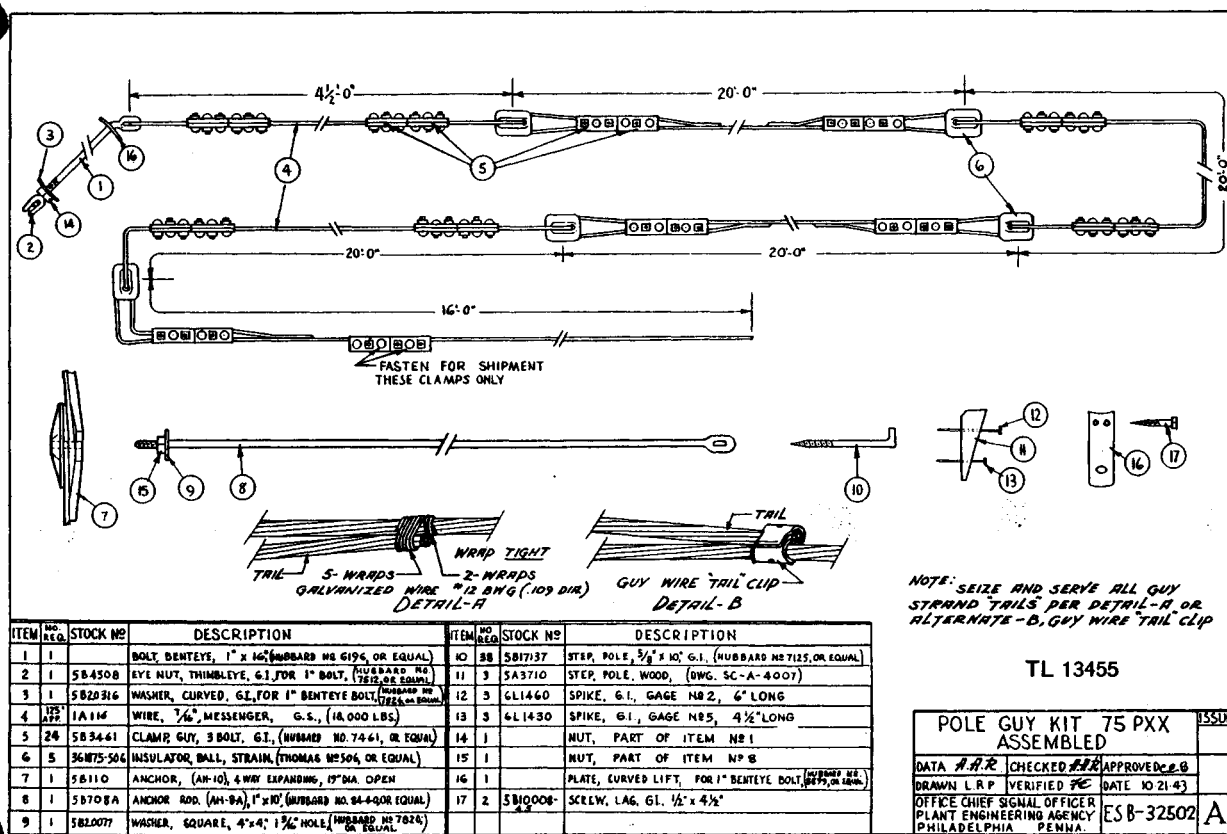

Figure 18. Pole guy 75PXX, dwg. ES-B-32502-A.

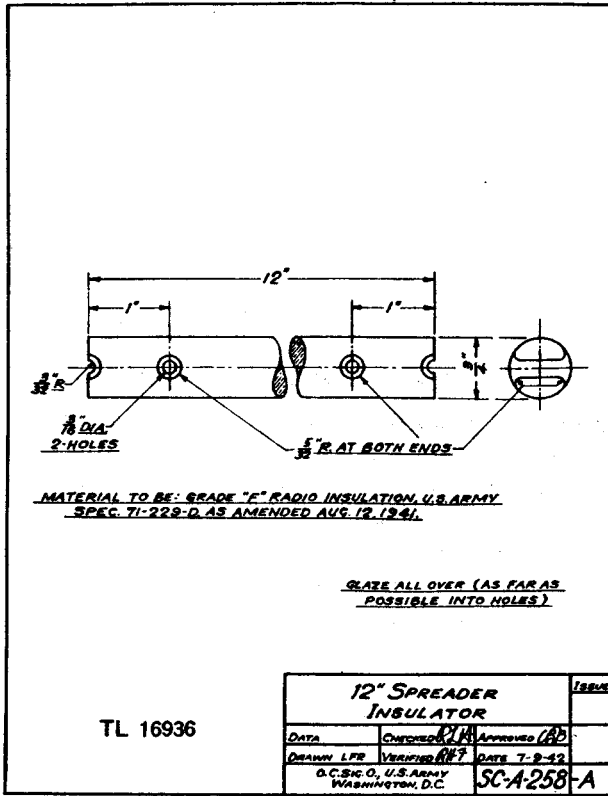

Figure 19. 12-inch spreader insulator, dwg. SC-A-258-A.

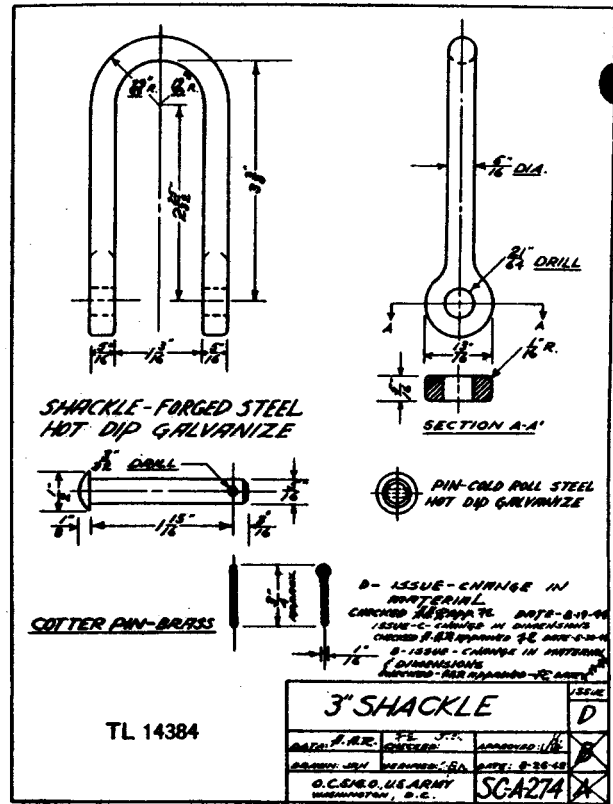

Figure 20. 3-inch shackle, dwg. SC-A-274-D.

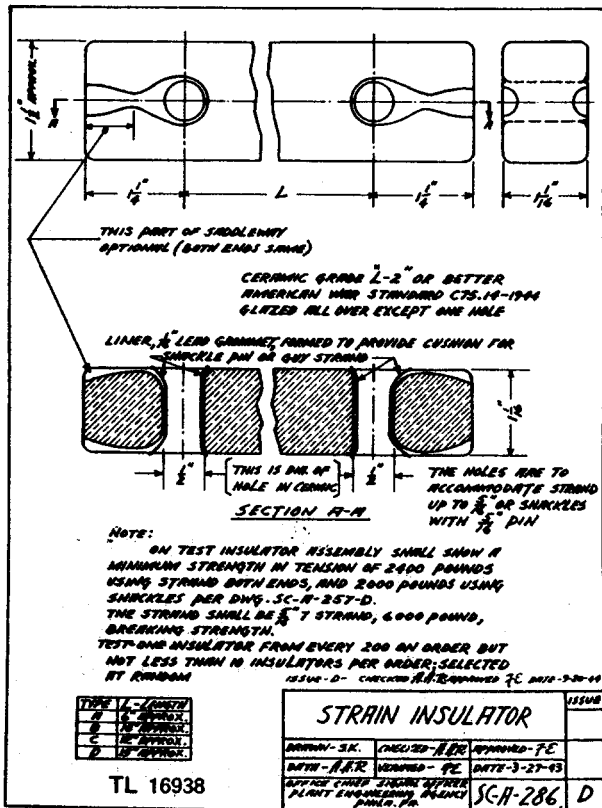

Figure 21. Strain insulator, dwg. SC-A-286-D.

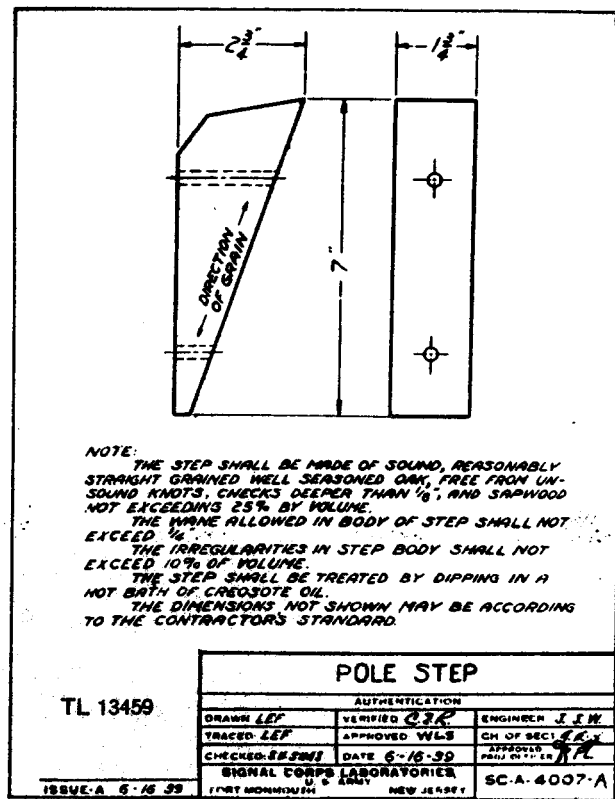

Figure 22. Pole step data, dwg. SC-A-4007-A.

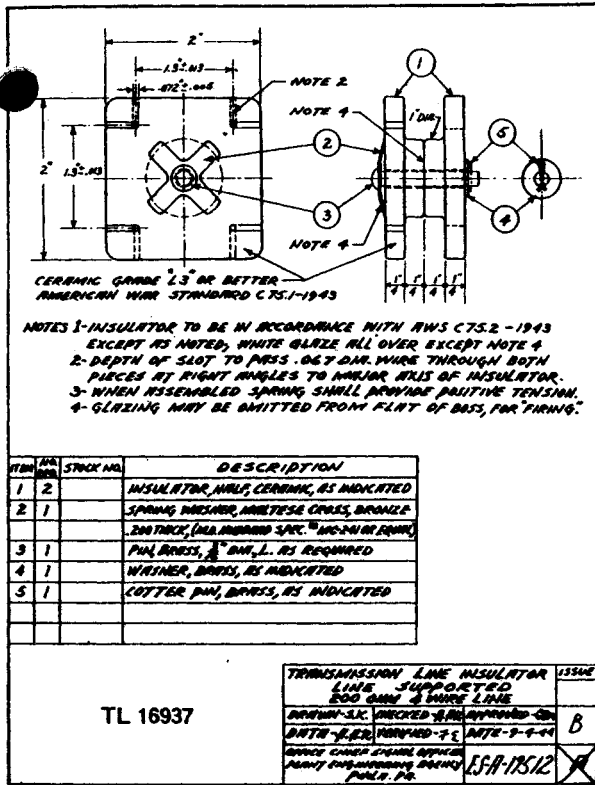

Figure 23. Transmission line insulator, line supported, dwg. ES-A-19512-B.

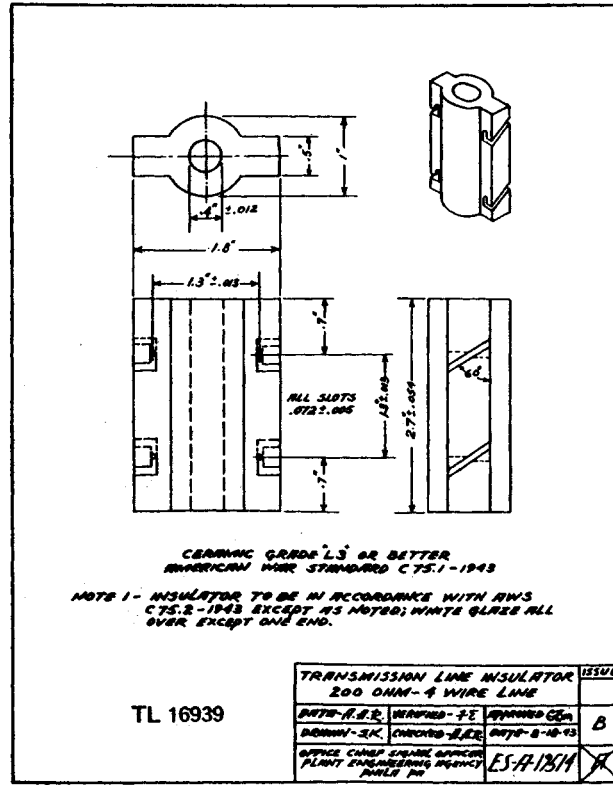

Figure 24. Transmission line insulator, line support, dwg. ES-A-19514-B.

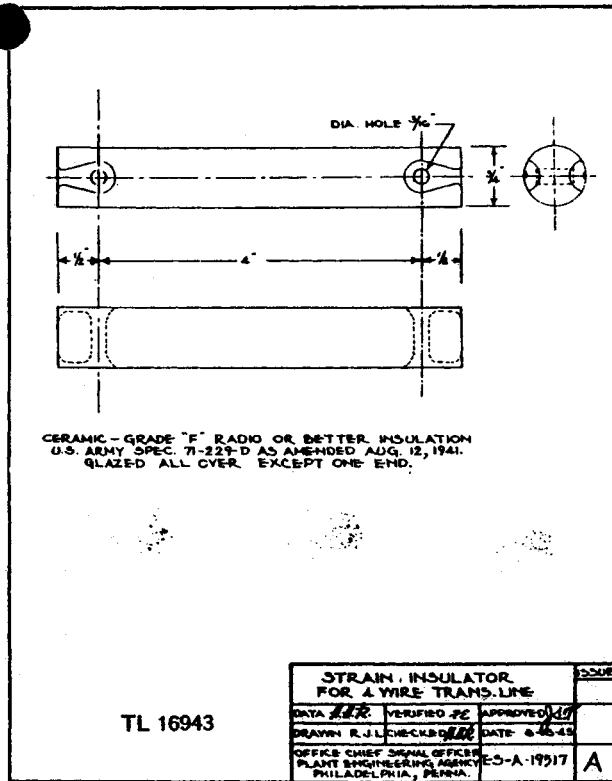

Figure 25. Strain insulator for 4-wire transmission line, dwg. ES-A-19517-A.

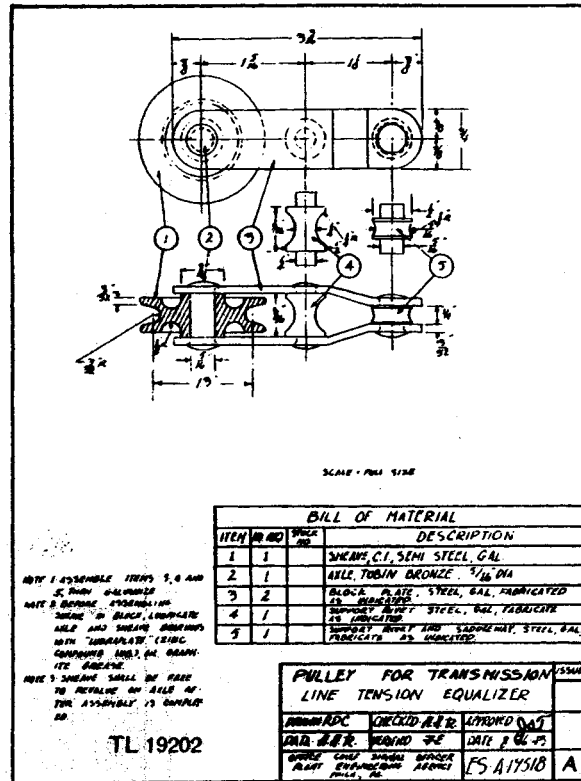

Figure 26. Dissipation line pulley, dwg. ES-A-19518-A.

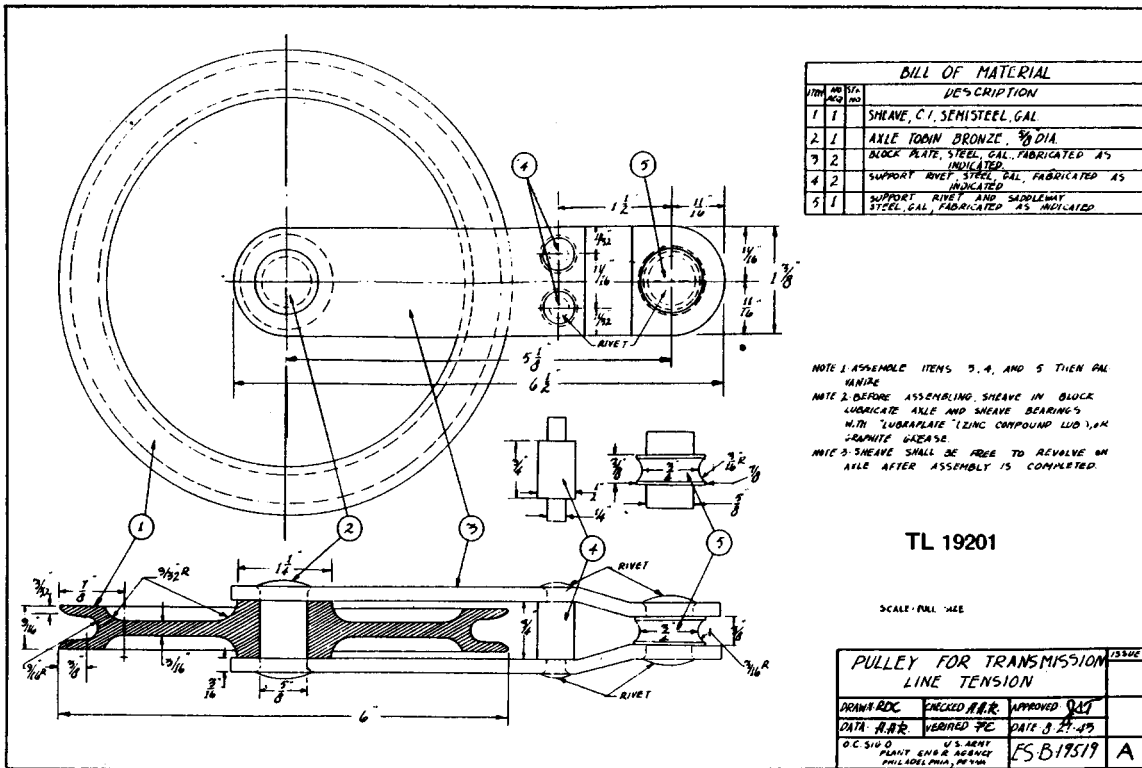

Figure 27. Dissipation line pulley, dwg. ES-B-19519-A.

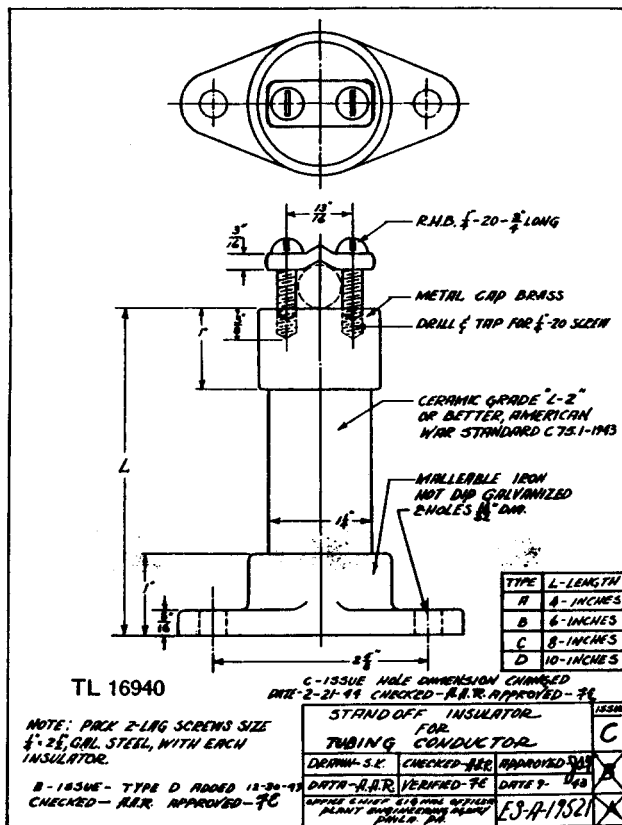

Figure 28. Stand-off insulator, dwg. ES-A-19521-C.

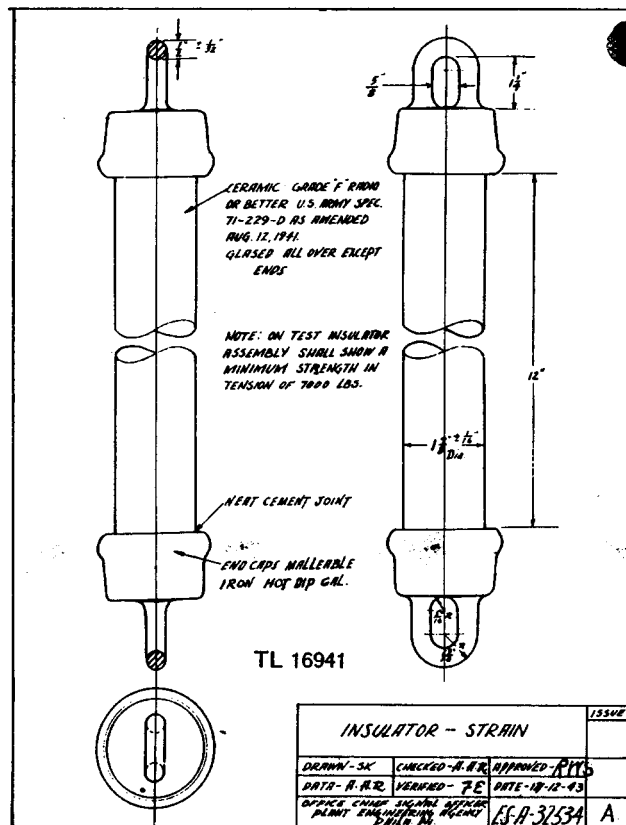

Figure 29. Strain insulator, dwg. ES-A-32534-A.



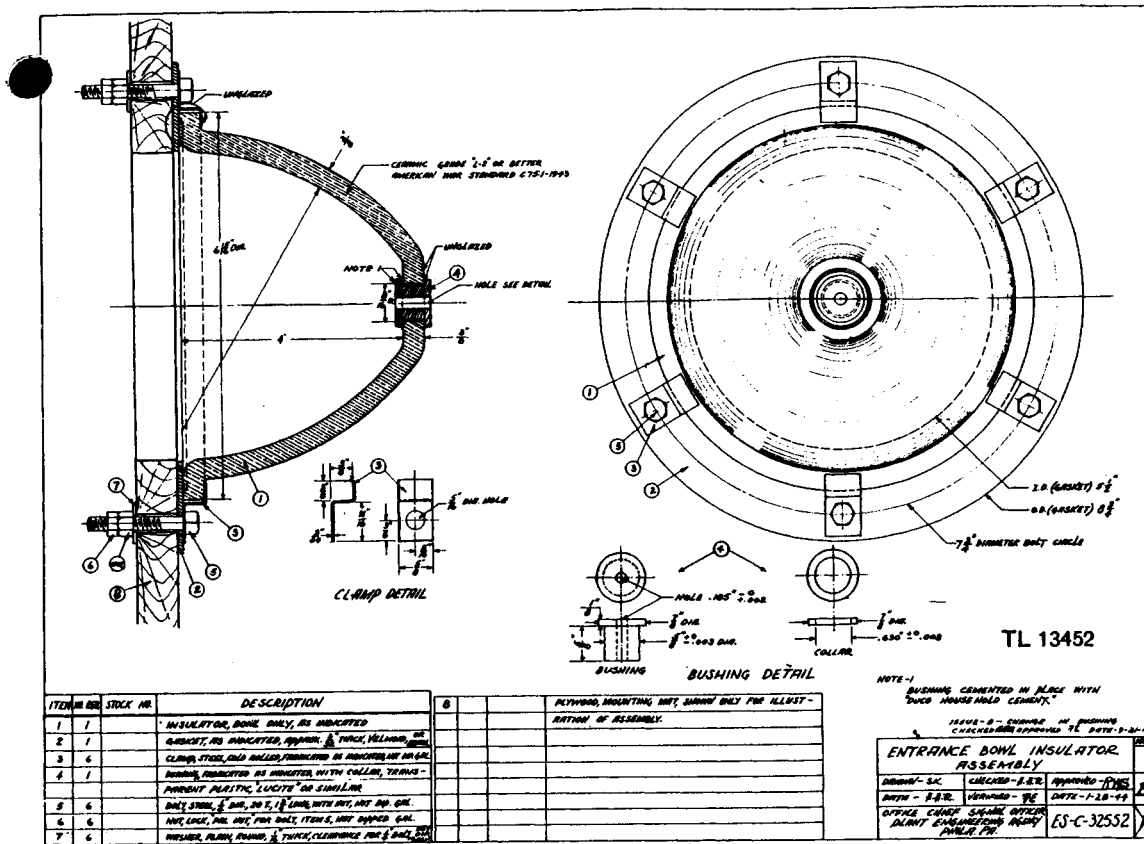

Figure 30. Bowl insulator, dwg. ES-C-32552-B.

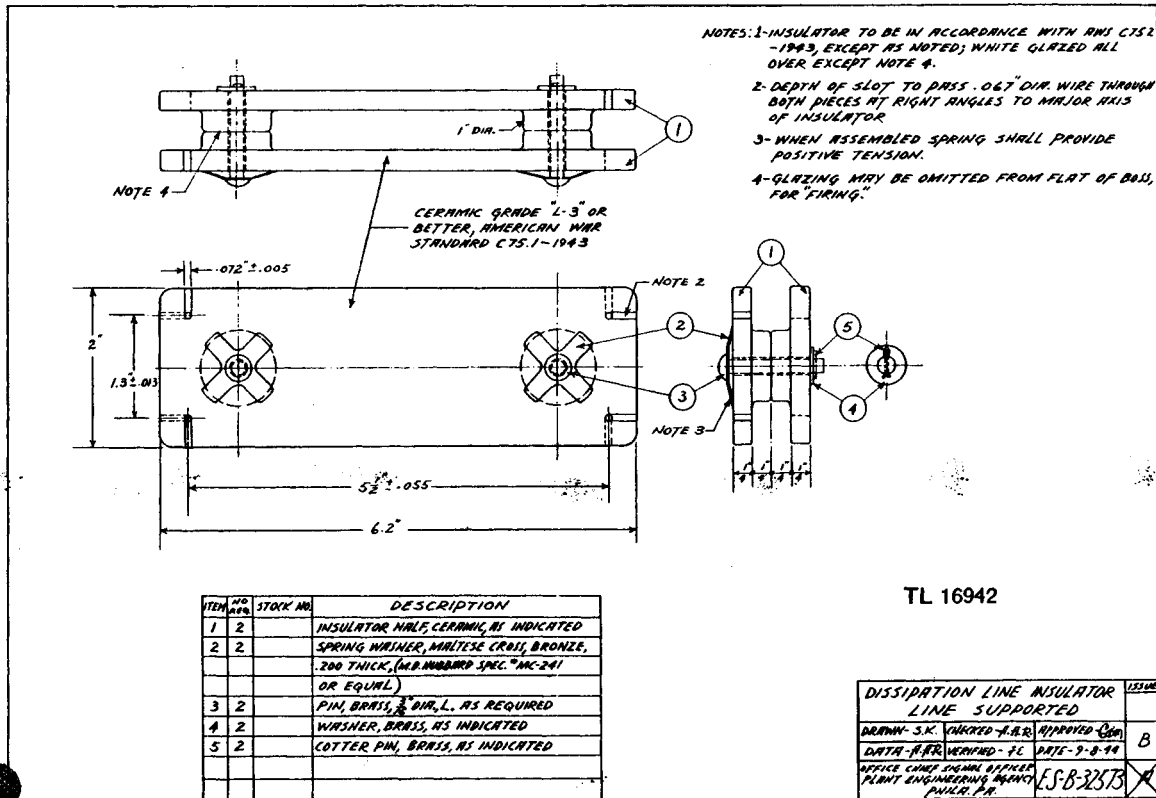
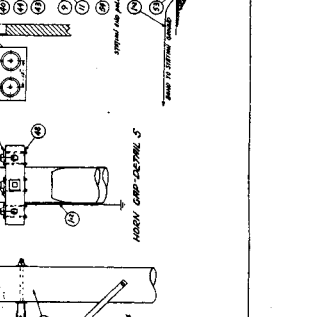
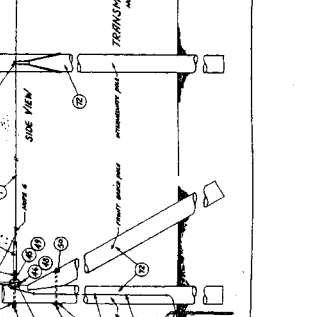
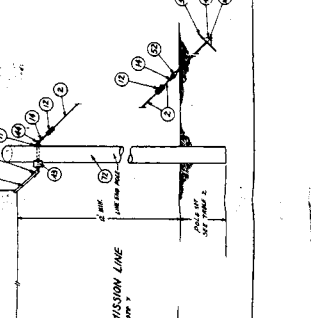
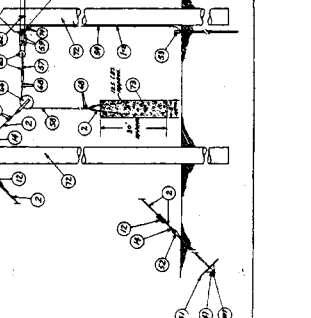
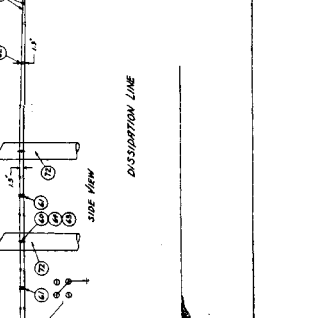
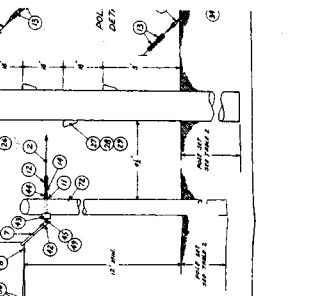
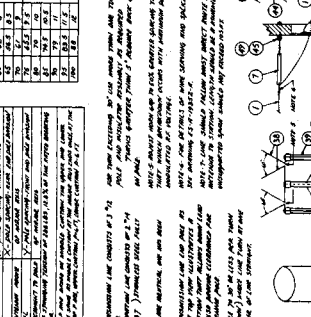
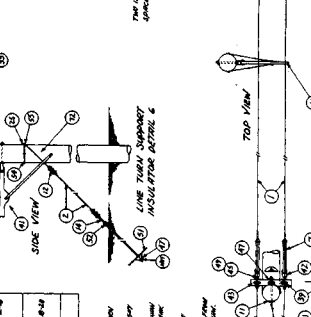
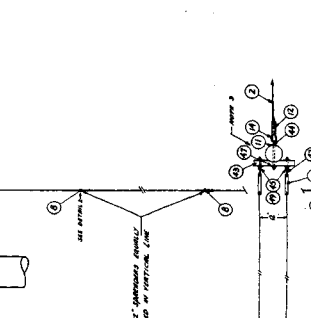
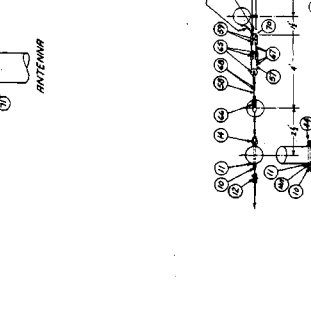
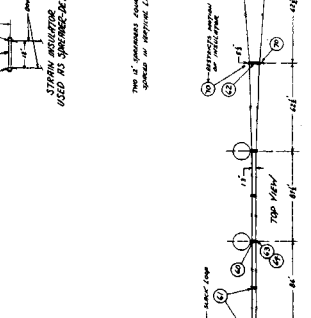
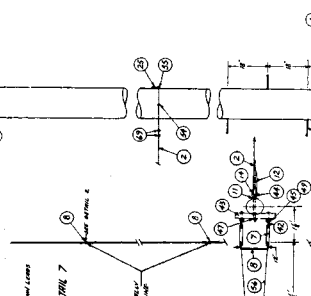
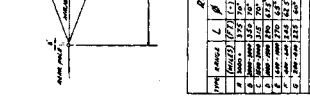
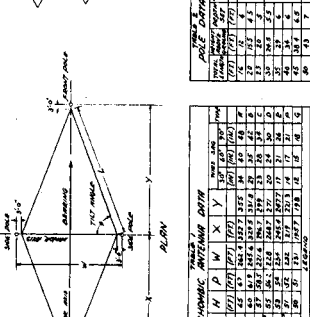
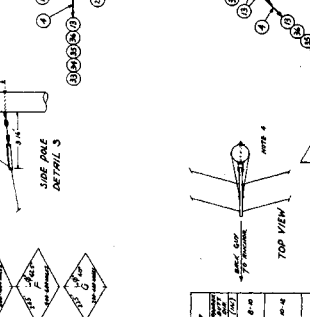
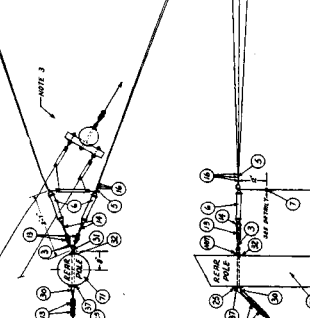
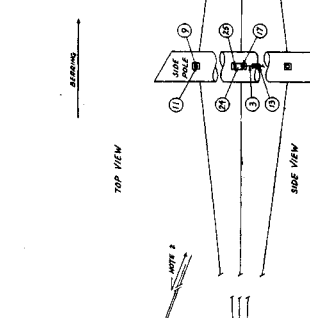
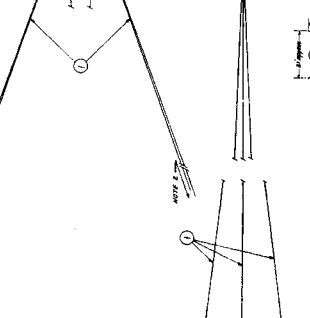
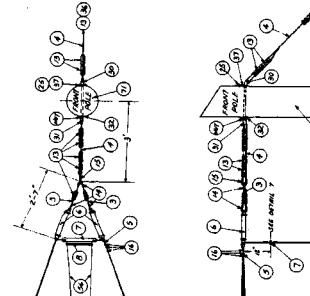
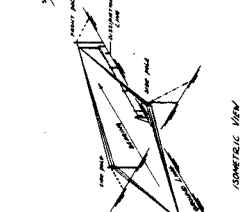
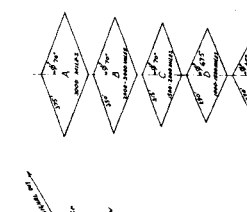
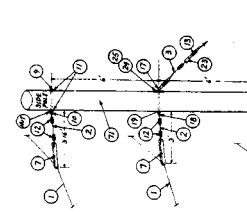
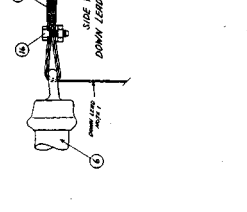
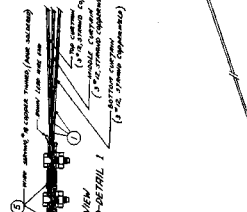
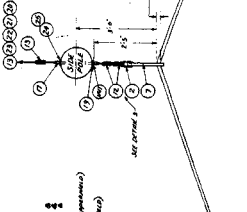
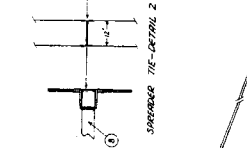
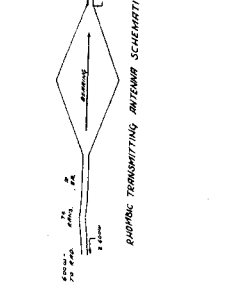

Figure 31. Dissipation line insulator, line supported, dwg. ES-B-32573-B.



ITEM NO.	DESCRIPTION	QTY	UNIT
1	...	...	...
2	...	...	...
3	...	...	...
4	...	...	...
5	...	...	...
6	...	...	...
7	...	...	...
8	...	...	...
9	...	...	...
10	...	...	...
11	...	...	...
12	...	...	...
13	...	...	...
14	...	...	...
15	...	...	...
16	...	...	...
17	...	...	...
18	...	...	...
19	...	...	...
20	...	...	...
21	...	...	...
22	...	...	...
23	...	...	...
24	...	...	...
25	...	...	...
26	...	...	...
27	...	...	...
28	...	...	...
29	...	...	...
30	...	...	...
31	...	...	...
32	...	...	...
33	...	...	...
34	...	...	...
35	...	...	...
36	...	...	...
37	...	...	...
38	...	...	...
39	...	...	...
40	...	...	...
41	...	...	...
42	...	...	...
43	...	...	...
44	...	...	...
45	...	...	...
46	...	...	...
47	...	...	...
48	...	...	...
49	...	...	...
50	...	...	...

ITEM NO.	DESCRIPTION	QTY	UNIT
1	...	...	...
2	...	...	...
3	...	...	...
4	...	...	...
5	...	...	...
6	...	...	...
7	...	...	...
8	...	...	...
9	...	...	...
10	...	...	...
11	...	...	...
12	...	...	...
13	...	...	...
14	...	...	...
15	...	...	...
16	...	...	...
17	...	...	...
18	...	...	...
19	...	...	...
20	...	...	...
21	...	...	...
22	...	...	...
23	...	...	...
24	...	...	...
25	...	...	...
26	...	...	...
27	...	...	...
28	...	...	...
29	...	...	...
30	...	...	...
31	...	...	...
32	...	...	...
33	...	...	...
34	...	...	...
35	...	...	...
36	...	...	...
37	...	...	...
38	...	...	...
39	...	...	...
40	...	...	...
41	...	...	...
42	...	...	...
43	...	...	...
44	...	...	...
45	...	...	...
46	...	...	...
47	...	...	...
48	...	...	...
49	...	...	...
50	...	...	...

ITEM NO.	DESCRIPTION	QTY	UNIT
1	...	...	...
2	...	...	...
3	...	...	...
4	...	...	...
5	...	...	...
6	...	...	...
7	...	...	...
8	...	...	...
9	...	...	...
10	...	...	...
11	...	...	...
12	...	...	...
13	...	...	...
14	...	...	...
15	...	...	...
16	...	...	...
17	...	...	...
18	...	...	...
19	...	...	...
20	...	...	...
21	...	...	...
22	...	...	...
23	...	...	...
24	...	...	...
25	...	...	...
26	...	...	...
27	...	...	...
28	...	...	...
29	...	...	...
30	...	...	...
31	...	...	...
32	...	...	...
33	...	...	...
34	...	...	...
35	...	...	...
36	...	...	...
37	...	...	...
38	...	...	...
39	...	...	...
40	...	...	...
41	...	...	...
42	...	...	...
43	...	...	...
44	...	...	...
45	...	...	...
46	...	...	...
47	...	...	...
48	...	...	...
49	...	...	...
50	...	...	...

ITEM NO.	DESCRIPTION	QTY	UNIT
1	...	...	...
2	...	...	...
3	...	...	...
4	...	...	...
5	...	...	...
6	...	...	...
7	...	...	...
8	...	...	...
9	...	...	...
10	...	...	...
11	...	...	...
12	...	...	...
13	...	...	...
14	...	...	...
15	...	...	...
16	...	...	...
17	...	...	...
18	...	...	...
19	...	...	...
20	...	...	...
21	...	...	...
22	...	...	...
23	...	...	...
24	...	...	...
25	...	...	...
26	...	...	...
27	...	...	...
28	...	...	...
29	...	...	...
30	...	...	...
31	...	...	...
32	...	...	...
33	...	...	...
34	...	...	...
35	...	...	...
36	...	...	...
37	...	...	...
38	...	...	...
39	...	...	...
40	...	...	...
41	...	...	...
42	...	...	...
43	...	...	...
44	...	...	...
45	...	...	...
46	...	...	...
47	...	...	...
48	...	...	...
49	...	...	...
50	...	...	...

