

Assembly Manual

SIX METRE 100 WATT BOOSTER AMP

K-6349

PLEASE READ DISCLAIMER CAREFULLY AS WE CAN ONLY GUARANTEE PARTS AND NOT THE LABOUR CONTENT YOU PROVIDE

Reproduced in part by arrangement with Australian Electronics Monthly, from their October 1987.

DICK SMITH
ELECTRONICS
PTY LTD
K I T

Dick Smith Electronics

Here's a booster amplifier that will give your six metre signal a bit more "sting". It's straightforward to assemble and align, and won't break the bank balance.

THIS ALL-MODE POWER AMPLIFIER was designed by the R & D department of Dick Smith Electronics and complements their existing range of amplifier kits for the two meter and seventy centimeter bands. Intended for use in the six meter amateur band, it boasts a continuous power output of 100 watts for an input of under six watts and is thus compatible with many popular amateur transceivers from low power portables to base station rigs of 10 watts or more output.

As anyone who has ever operated on six meters will tell you, it can be one of the most fascinating of all the amateur bands. With the two "DX seasons" a year – winter and summer, the latter being the most spectacular – and the sunspot cycle once again on the rise, now is the time to start planning that station upgrade you promised yourself. Although there are times when some quite good DX can be worked with very modest equipment, there is often no substitute for a bit more power and this timely project should prove a useful addition to many stations.

FEATURES

- Mobile or base operation
- Carrier operated relay (COR)
- Over-voltage and transient protection
- Reverse polarity protection
- Switchable between-syllable delay for SSB
- Power and on-air indication
- Relative output power metering
- Remote dc output for preamps etc.
- Optional attenuator

Design

Design of the amplifier is based around a pair of Motorola MRF492 transistors. These are a low-band VHF device and reference to the manufacturer's data (see the data sheet elsewhere in this issue) shows that they are intended for FM power amplifier use. A closer examination of the data reveals



Styling of the 6m all-mode amp matches that of the 2m and 70 cm amps, with a topside heatsink and folded aluminium housing. The front panel meter indicates relative power output.

als that the devices exhibit sufficient linearity for SSB applications up to 60 watts when they are biased within the linear portion of their curve.

Tests performed on the prototype amplifiers indicate that optimum bias conditions exist when operated somewhere between class A and class AB where the idling current of the individual transistors is between 0.5 amps and 1.5 amps.

Construction

For ease of construction, all components are mounted on a printed circuit which features solder-tinned tracks and silk-screened component annotation. The board measures 218 mm x 130 mm and it is mounted on a large, anodised heat-sink to allow continuous operation of the output transistors at high power levels. You should first familiarise yourself with the layout of the board so that you have a good idea where all the components are sited.

Commence construction by first fitting all the pcb pins into the board. Note that the pin locations designated by the letters "FT" are feedthroughs used to connect the copper foil on both sides of the board. These must be soldered on both sides and can be cut short after fitting. The pin locations designated by the letter "T" are used for wiring terminations. Where possible, these should be soldered on both sides of the board, but they should not be cut short after fitting.

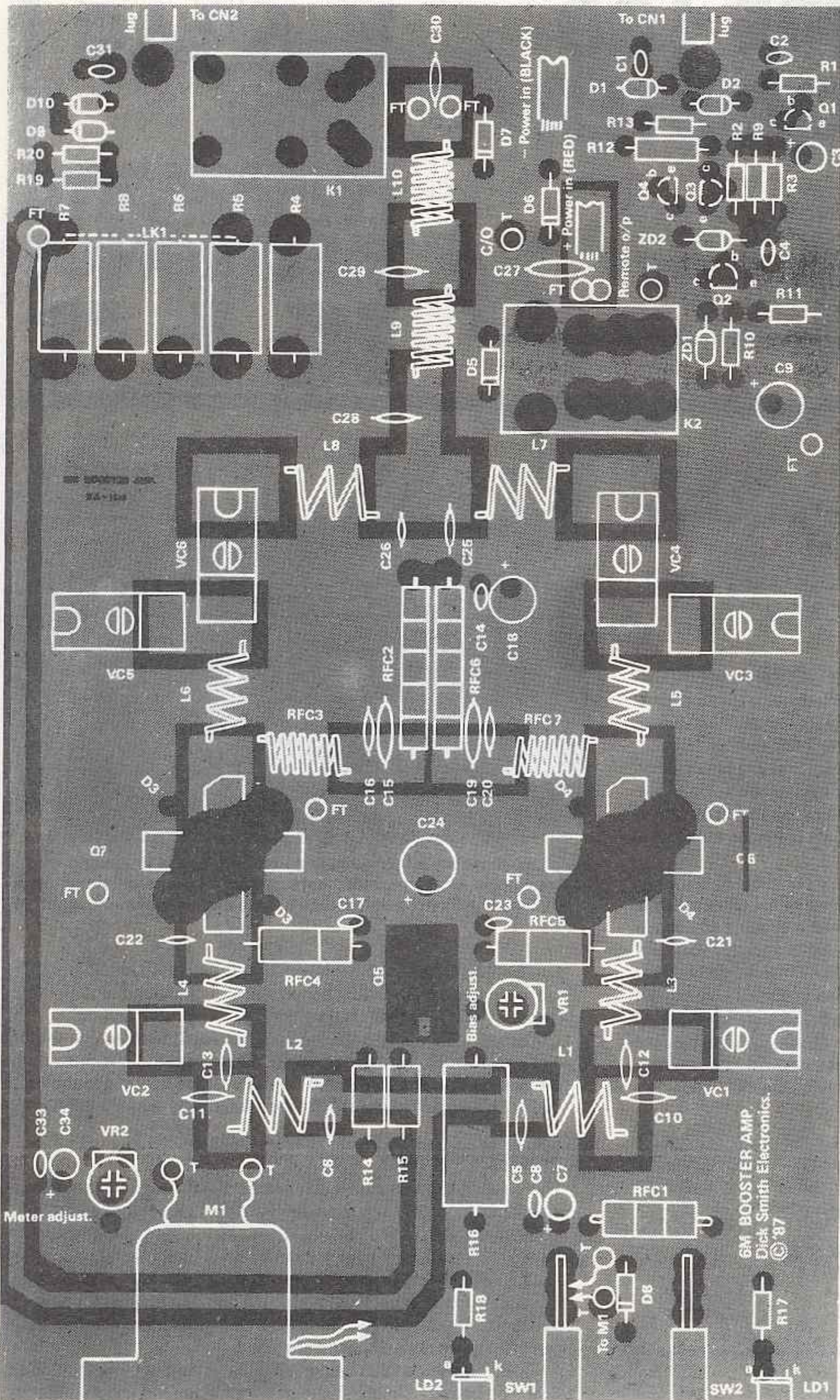

Figure 1. How the disc ceramic capacitors are prepared and installed.

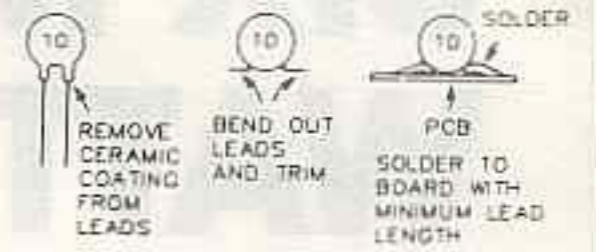
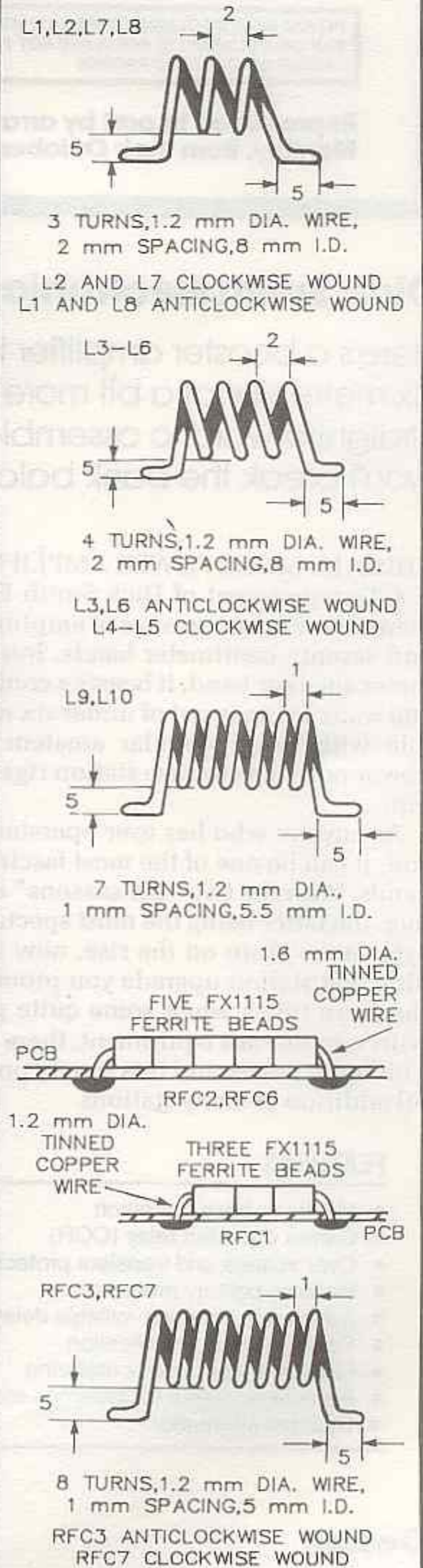
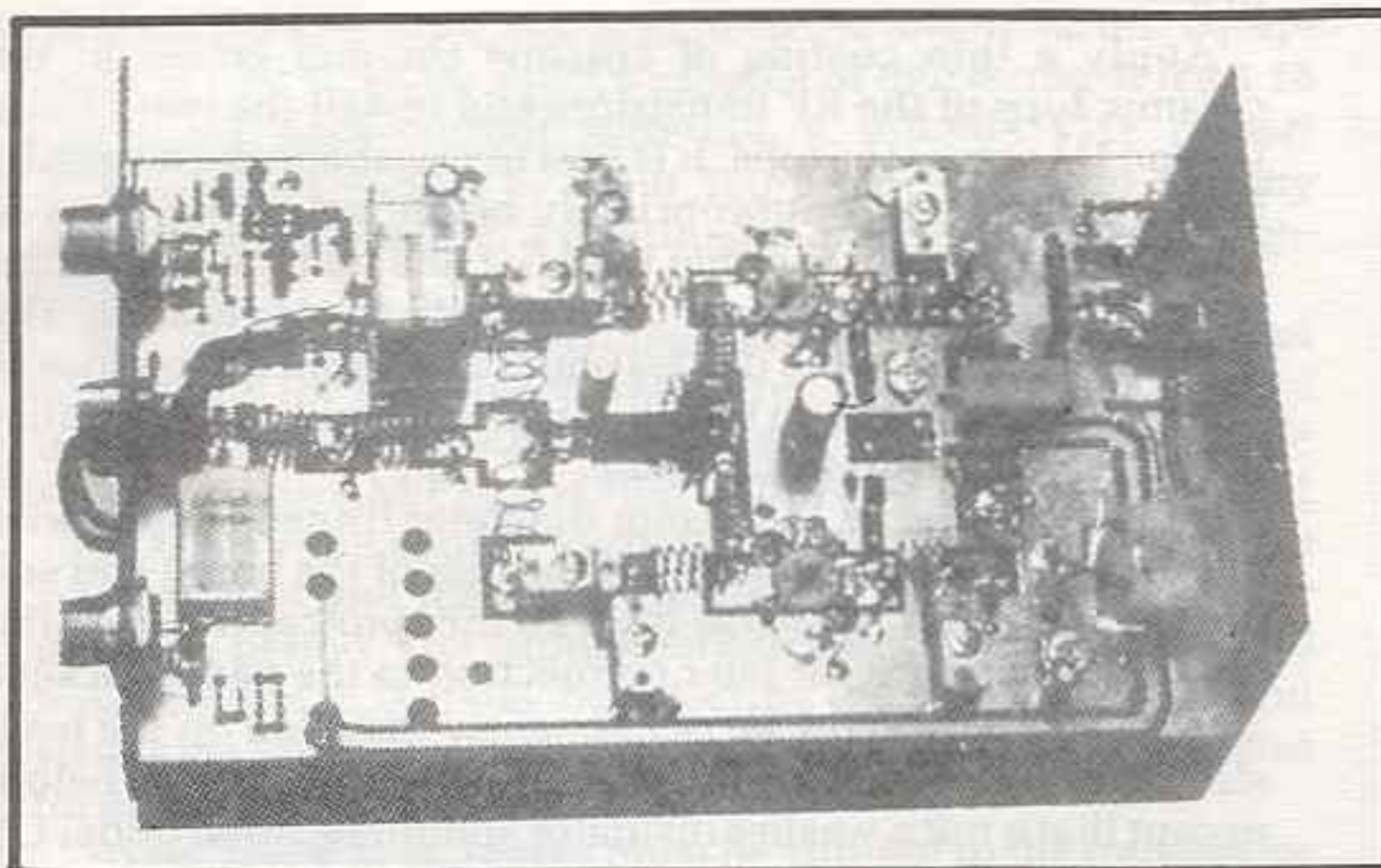

Figure 3.





On the inside. The layout is quite straightforward making assembly relatively easy. All componentry is mounted on a single double-sided pc board, the topside being virtually all groundplane.

PARTS LIST

Semiconductors

D1-D2	1N4148
D3-D8	1N4004
D9-D10	1N4148
ZD1	15 V/400 mW zener
ZD2	3V3/1 W zener
LD1	TL4213, 5 mm red LED
LD2	TL4233, 5 mm green LED
Q1	BC337
Q2-Q3	BC557
Q4	BC337
Q5	BD139
Q6-Q7	MRF492

Resistors

all 1/4 W, 5% unless noted

R1	100k
R2	56k
R3	10k
R4-R5	27R, 2 W
R6	180R, 2 W
R7	12R, 2 W
R8	180R, 2 W
R9	3k3
R10	100R
R11	150R
R12	270R, 1/2 W
R13	10k
R14-R15	220R, 1 W
R16	39R, 5 W
R17-R18	1k
R19	2k7
R20	470R
VR1	100R hor. trimpot
VR2	10k hor. trimpot

Capacitors

C1	1p disc ceramic
C2	100p disc ceramic
C3	22u/16 V tant.
C4	10n disc ceramic
C5	47p disc ceramic
C6	39p disc ceramic
C7	22u/16 V tant.
C8	10n disc ceramic
C9	100u/25 V RB electro.
C10-C11	47p disc ceramic
C12-C13	270p disc ceramic
C14	10n disc ceramic
C15	100n disc ceramic
C16-C17	10n disc ceramic
C18	100u/25 V RB electro.
C19	100n disc ceramic
C20	10n disc ceramic
C21-C22	1n disc ceramic
C23	10n disc ceramic
C24	1000u/16 V RB electro.
C25	47p disc ceramic
C26	39p disc ceramic

C27	100n disc ceramic
C28	68p disc ceramic
C29	120p disc ceramic
C30	68p disc ceramic
C31	1p disc ceramic
C32-C33	10n disc ceramic
C34	10u/25 V RB electro.
VC1-VC2	130p-450p trimmer, Arco C4210, "C" mounting type
VC3	95p-350p trimmer, Arco C428, "C" mounting type
VC4	55p-250p trimmer, Arco C426, "C" mounting type
VC5	95p-350p trimmer, Arco C428, "C" mounting type
VC6	55p-250p trimmer, Arco C426, "C" mounting type

Miscellaneous

SW1-SW2	Spdt toggle switch, pc board mounting
RLA1	DPDT relay, Siemens V23012, 12 V coil
RLA2	DPDT relay, 10 A contacts, 12 V coil
CN1-CN2	SO-239 single hole mount, with earth lug
CN3	panel mount RCA socket
M1	500 uA signal strength meter with backlight
RFC1-RFC3	see text
RFC4-RFC5	47 uH axial
RFC6-RFC7	see text
ZA-1516	double-sided pc board; folded aluminium enclosure with front and rear panels; Black anodised and machined heatsink; Aluminium transistor mounting plate; 15 FX115 ferrite beads; two meters of 1.2 mm dia. tinned copper wire; 30 cm of 1.6 mm dia. tinned copper wire; 20 cm of small gauge hookup wire; one meter each of red and black 4 mm diameter power cable; 20 amp 3AG fuse with in-line fuseholder; one captive type cable grommet; four self-adhesive rubber feet; 20 pc board pins; one TO-220 mica insulator; silicone thermal grease; 15 off 3 x 8 mm machine screws; four off #6 x 6 mm self-tapping screws; two off #4 x 6 mm self-tapping screws; four x 4BA hex nuts.

The resistors, capacitors and the two horizontal trimpots can be mounted next. Resistors R14, R15 and R16 (220 ohm/1 W and 39 ohm, 5 W) should be mounted 3 mm above the board to allow for heat dissipation and to prevent coupling effects from the RF track which runs underneath. If required, the five resistors for the input attenuator can be fitted at this stage. You should refer to the "input attenuator" section for details of this operation. If an input attenuator is not required, you can replace the resistors with a 27 mm long piece of 1.7 mm diameter tinned copper wire, indicated as LK1 on the component overlay.

The components C5, C6, C10-C13, C15-C16, C19-C22 and C25-C30 are all soldered to the top of the pc board with their leads spread out and cut to minimum length. Refer to Figure 1 for preparation and fitting of these components.

The trimmer capacitors can now be fitted to the board. Pay particular attention to their orientation as indicated by the component overlay. The trimmers VC1, VC4 and VC6 have their earth (screw) side soldered to the top surface of the pc board only, whilst trimmers VC2, VC3 and VC5 are soldered on both sides of the board. Take care to trim the soldered joints on the underside of the board to prevent possible shorts to the heatsink.

You can now fit all the semiconductors with the exception of D3, D4, Q5, Q6 and Q7. Take care with the orientation of these components and try to keep the leads as short as practicable. Where pads exist, you should solder the connections on both sides of the pc board, particularly with connections to the ground plane such as the emitter of Q1. The LEDs, switches and relays can also be installed at this point. Install the switches first and then position the LEDs and bend them so that they are on the same centre line as the switches.

The next step is to construct and install the RF chokes RFC1, RFC2 and RFC6. Refer to Figure 3 for details of the choke construction and check that you use the correct diameter tinned copper wire. RFC1 is made from three ferrite beads over a 19 mm long piece of 1.2 mm tinned copper wire. Before fitting the beads, bend one end of the wire at a right angle. You can then slide the three beads onto the wire and bend the other end to keep them in place.

RFC2 and RFC6 are constructed in a similar manner but use five beads on a 30 mm length of 1.7 mm diameter tinned copper wire. Be very careful when bending the wire, especially the 1.7 mm diameter wire used for RFC2 and RFC6, as the ferrite beads are fragile and it is easy to shatter them. Using a pair of needle-nosed pliers at the bend to grip the wire between the beads and the point of the bend is the best method. If you wish, a small amount of "Super Glue" can be used to stop the beads moving after the chokes have been soldered in place.

Mounting the power transistors

Mounting the power transistors requires a fair bit of care and the following steps should be followed closely to avoid causing permanent damage to the devices through mechanical stress.

Apply a very light coating of solder to the undersides of the leads of Q6 and Q7. You may also do the same for the areas where the leads of these devices will contact the pc board, as indicated by the overlay, although the tinning on the board should be sufficient. Do NOT install the transistors at this point. Next, prepare the bias transistor, Q5, by bending its leads at a right angle 3 mm from the bottom edge of the package such that the leads will point up and away from the metal side of the transistor package. Insert the leads of Q5 into their respective holes from the underside of the pc board as indicated by the overlay. Splay the leads a little to hold the device in place, but do NOT solder Q5 in position yet.

With reference to Figure 4, position the aluminium plate onto the heatsink. Position the four hex nuts as per the diagram and carefully position the pc board on top of the assem-

bly. These nuts are used as spacers and are thus a clearance fit over the 3 mm x 8 mm machine screws which hold the pc board on the heatsink. Place the MRF429 transistors, Q6 and Q7, into their indicated positions, observing the correct polarity. The transistor mounting holes and the pc board mounting holes should be aligned with their respective holes in the heatsink.

The sides of the pc board should be parallel to the edges of the heatsink and there should be about 1 mm clearance from the ends of the board to the front and rear of the heatsink. With the assembly thus aligned, insert the nine 3 mm x 8 mm machine screws in their respective holes and tighten them down. Do not use excessive force, particularly when screwing down Q5, the case of which may shatter as a result.

The power transistors can now be soldered in place. Apply solder to the leads of the RF devices Q6 and Q7, using only the minimum amount required to make a good connection. "Sweat" the connections by pressing the flat of the soldering iron on the upper surface of each transistor's lead so that the solder on the undersides melts. This method allows the transistors to be mounted with the minimum mechanical stress.

Solder the collector of the bias transistor Q5 to its pad and cut off the excess leads protruding on the component side of the board. Now remove the board assembly from the heatsink. When removing and installing the pc board on the heatsink, always remember to loosen the transistors first and tighten them last. This prevents the transistors from becoming stressed by allowing the hex nut spacers to support the weight of the pc board. You may now solder the remaining leads of Q5 to their pads.

The board is now ready to accept the coils. Prepare RF chokes RFC4 and RFC5 by sleeving a ferrite bead over one end. The lead with the ferrite bead fitted is inserted into the pc board and soldered in place. The other lead is soldered on the component side of the board to the copper pads associated with the bases of the RF transistors.

Prepare the ten coils as per Figure 3, taking care to use the correct diameter tinned copper wire. Owing to the characteristic "symmetrical" layout of the amplifier, the opposing coils of each "half" should be wound in opposite directions to facilitate mounting. Note that L9 and L10 are wound in the same direction. The coils are mounted on the surface of the

component side of the board by gripping with a pair of needle-nose pliers and soldering in place. It should not be necessary to re-locate any of the adjacent capacitors to accommodate the coils if you take heed of their position in the first place.

Apply a thin coating of silicone thermal grease to the ceramic tops of the RF transistors and install the two diodes D3 and D4 across the tops. It is best to pre-shape the diodes by bending their leads appropriately before soldering them in place. For optimum thermal tracking, the body of the diodes should make tight physical contact with the transistors. The protruding leads of the diodes should be trimmed as close as possible to the board on the underside to avoid the possibility of shorts to the aluminium plate.

Insert two lengths of 1.7 mm diameter tinned copper wire into the RF connection holes at the rear of the board and solder them in place. Leave at least 20 mm protruding from the top of the pc board for later connection to the panel sockets. The pc board can now be permanently installed on the heatsink. The procedure for this operation is the same as before except that a mica washer insulator should be fitted under Q5 and a thin coating of silicone thermal grease applied to the undersides of the transistors, the mica washer and the aluminium plate. Ensure that the pc board is correctly aligned before tightening the screws and remember to tighten the transistor bolts last.

The front and rear panels can be mounted next. These are attached to the heatsink by means of #6 x 12 mm self-tapping screws which are screwed into the channels provided in the heatsink. As these screws require a fair amount of force to cut a thread in the channels, it is wise to pre-tap the channels by screwing in the self-tappers with the panels off, thus avoiding the possibility of damage due to the screwdriver slipping. Attach the SO-239 sockets and the RCA connector to the rear panel and ensure that the earth lugs on the RF sockets are fitted. Screw the panel onto the heatsink, then bend and position the earth lugs of the RF sockets such that they can be soldered to the top of the pc board.

Prepare the heavy duty red and black power leads by first installing the in-line fuse in the red lead as per Figure 2, then strip 10 mm of insulation from one end of each lead. Solder the red and black leads to their respective points on the pc board as indicated by the overlay. Feed the wire through the large centre hole in the rear panel and secure in place with the captive grommet.

Run a length of light gauge insulated hookup wire from the pcb pin marked "remote o/p" to the centre conductor of the RCA connector and install the 10n (0.01 uF) capacitor, C32, between the centre conductor of the RCA connector and the back panel. The two previously installed 1.7 mm diameter tinned copper wires are now bent over at a right angle and soldered to the centre conductors of their respective SO-239 sockets.

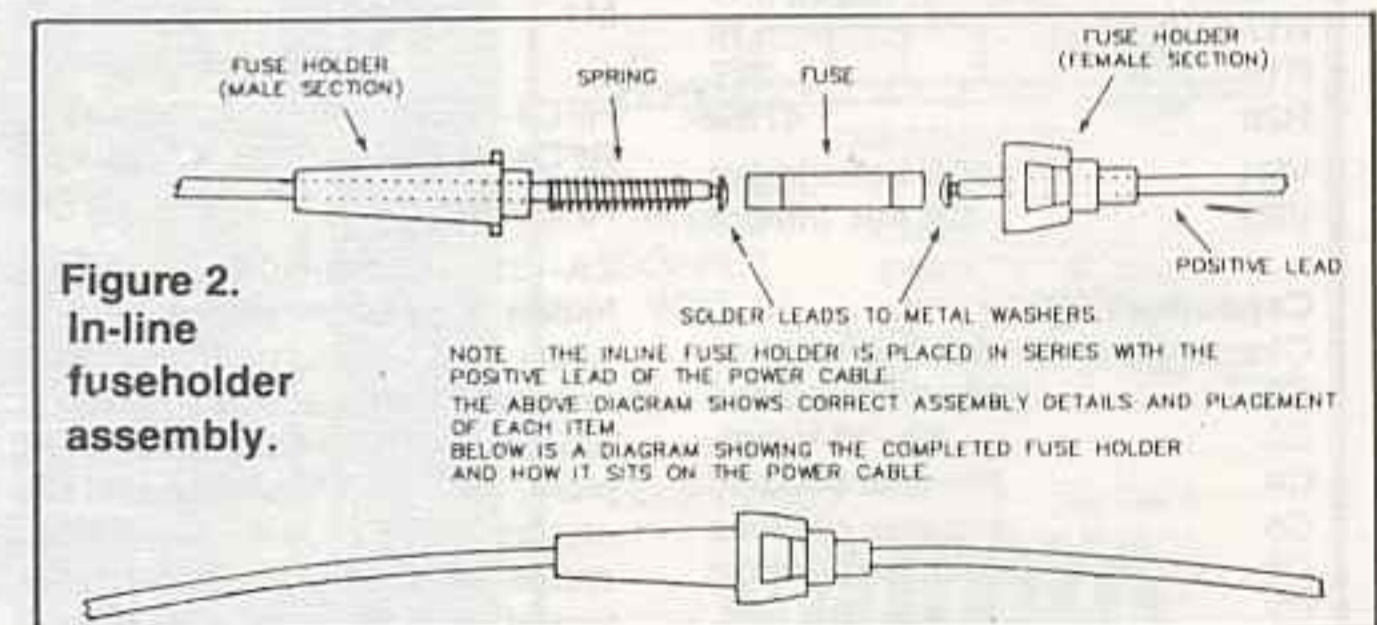

All that now remains of the construction is to fit the front panel and install the meter. Screw the front panel to the heatsink after pre-tapping the channels as you did with the rear panel, then, after applying a small amount of contact adhesive to the top of the meter, seat it in place on top of the pc board such that it aligns with the cutout window in the panel. The switches and LEDs should also be protruding through their respective holes. Cut the leads for the meter backlight to the required length and terminate to the pcb pins indicated on the overlay. Use the off-cuts to connect the meter coil terminals to their respective pins.

Figure 4.

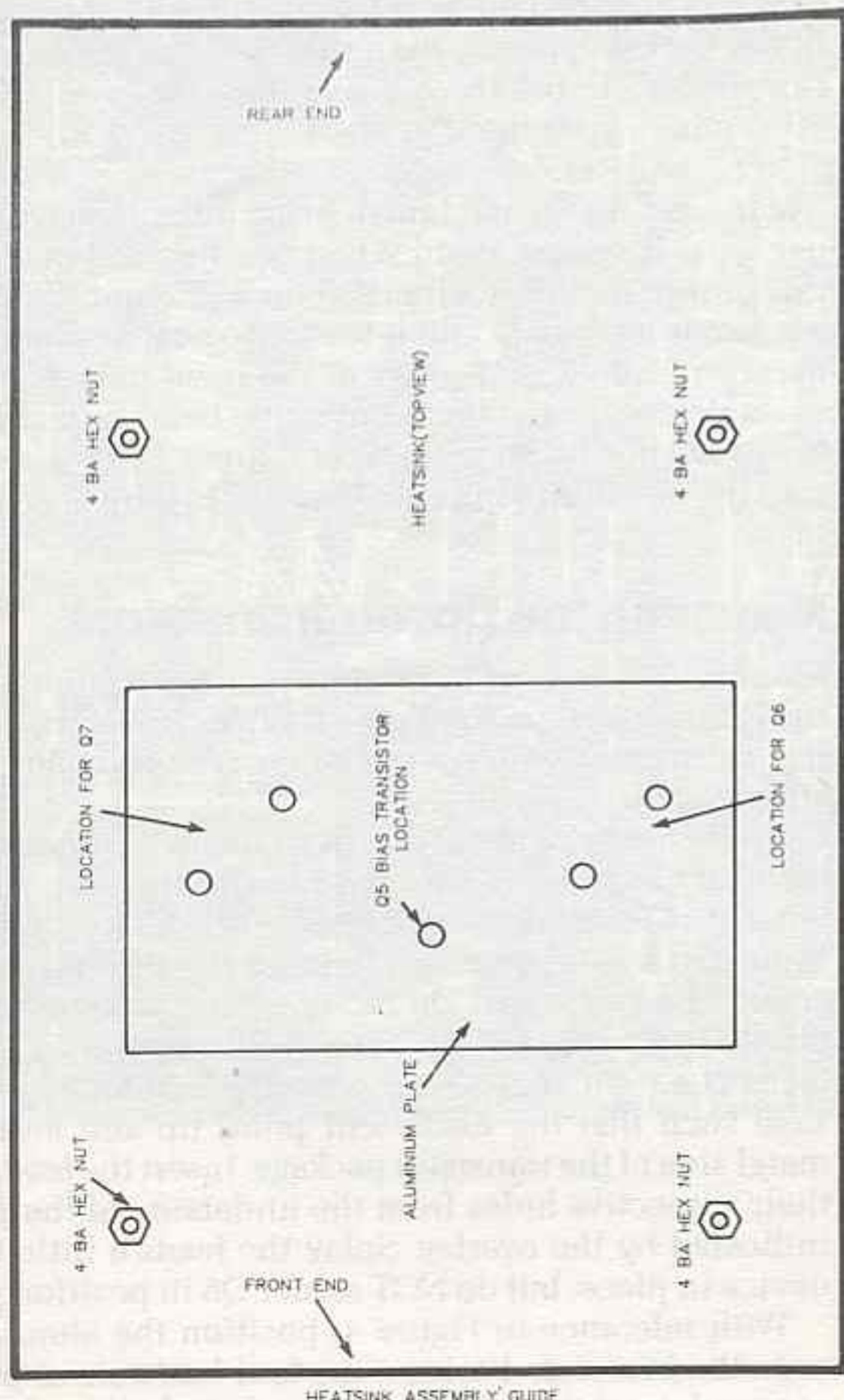

This completes assembly of the amplifier. The next step is to test and align the unit.

Alignment

To align the amplifier, you will need the following test equipment: a 13.8 V power supply capable of delivering at least 18 amps and with current metering, a suitable VHF power/VSWR meter reading to about 150 watts, a 50 ohm dummy load of suitable rating, a multimeter and a non-ferrous alignment tool.

The first step in the alignment process is to set the dc bias conditions for the power transistors. Turn the bias control trimpot VR1 fully clockwise and select the front panel mode switch to the AM/FM position. Apply dc power to the unit and observe the supply current. The relays should energise momentarily and the green "on-air" LED will illuminate for the same period. The supply current should now be about 50 mA. Test the VOX delay by selecting the SSB/CW mode and switching the unit off and then on. The relays should energise for approximately two seconds.

To set the dc bias, power must be applied to the transistors. To achieve this, the carrier operated relay (COR) circuit should be enabled by shorting the COR override pin (marked as C/O on the overlay) to ground. When this is done, the relays will energise and the "on-air" LED will illuminate. The supply current should be around 300 mA.

Adjust VR1 until the supply current increases by two amps. The collector currents of Q6 and Q7 will be about one amp each as large dc gain variations are not expected for these devices. This can be confirmed by opening the collector coils RFC3 and RFC7 one at a time and measuring the current to the collector. There is no reason for concern if variations are found as there will be negligible effect on the amplifier's overall performance. Disable the COR circuit by removing the jumper and remove power from the amplifier.

Having set the dc bias, you are now ready to perform the RF alignment. Some words of caution here; the output coils and capacitors will be "hot" at RF. You should take great care to avoid contact with these areas and use only an insulated aligning tool, or severe burns can result. The alignment steps should be performed as quickly as possible to avoid damage to the RF power devices and other components as there will be high circulating currents present, particularly when the transistors are driven into reactive loads. Finally, always ensure that whilst aligning the amplifier, it is terminated in a suitably rated, non-reactive dummy load. It is unwise to use an antenna, as misleading results can be obtained and there is a strong possibility that you will cause interference.

Commence by backing off all the trimmers two turns from their tight position. Terminate the output with a dummy load and a suitable power meter. If a suitable power meter cannot be obtained, it is possible to use the front panel meter of the amplifier, bearing in mind that it gives only a relative indication and can give erroneous readings if the amplifier is not terminated in the correct (50 ohms) load. Connect an exciter to the amplifier's input and apply a drive of one watt or less. As amateurs in Australia are now virtually unable to use the part of the six metre band between 50 and 52 MHz due to channel 0 television, it would be best to align the unit at a center frequency of 53 MHz.

As the drive is applied, the COR circuit should be enabled and the relays should energise. Adjust the output trimmers

SPECIFICATIONS MEASURED ON PROTOTYPE

Amplifier mode:

Continuous power output	120 W CW
Saturated power output	150 W CW
Gain	12 dB to 14 dB
Efficiency	45% (15 A/13.8 V for 100 W)
Modes	CW, AM, FM and SSB
Bias	Variable
Input VSWR	1.5:1
1 dB bandwidth	50 MHz to 54 MHz
Harmonics	-63 dB (2nd harmonic)

Standby mode:

Input VSWR	1.1:1
Insertion loss	0.2 dB

Motorola MRF 492 DATA SHEET

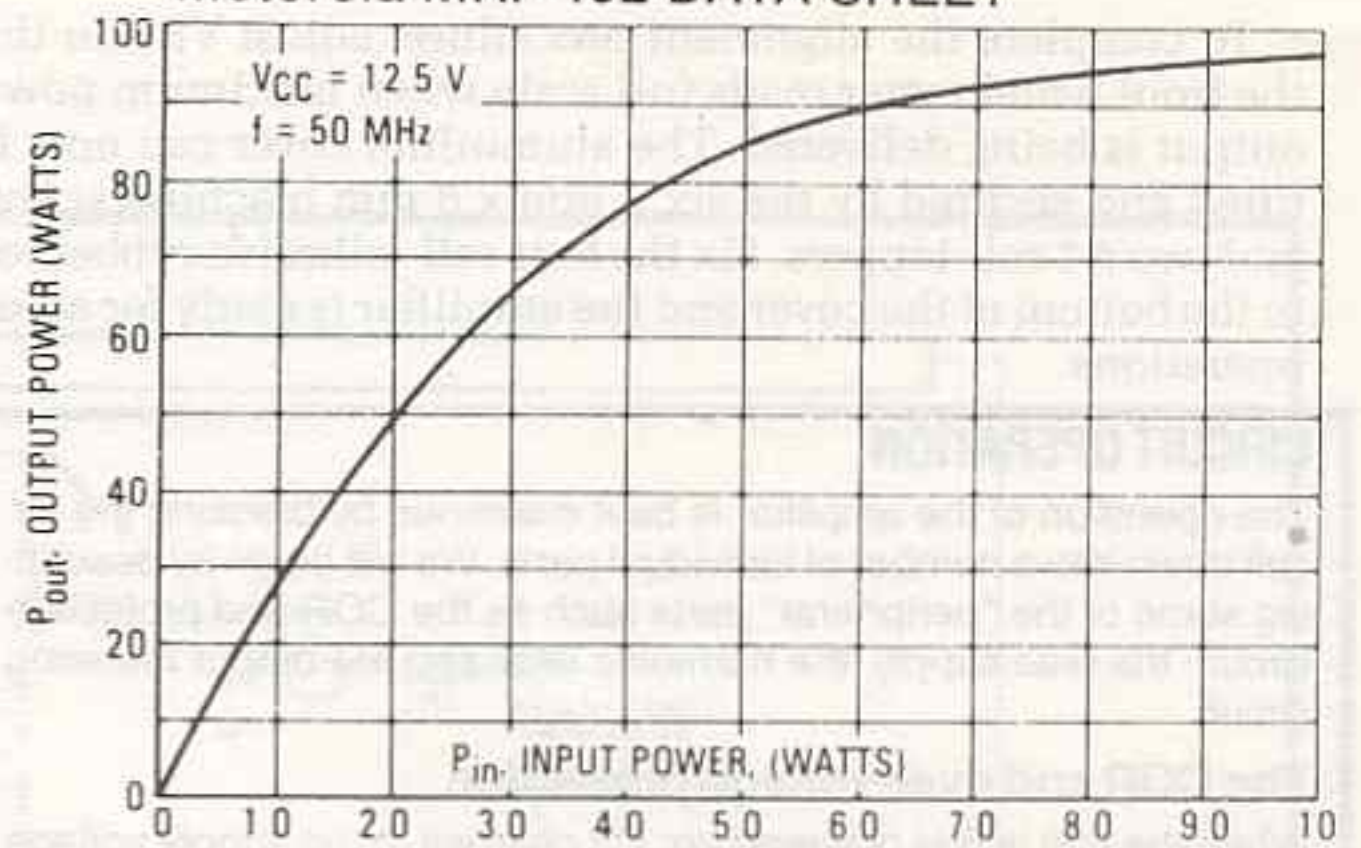

— OUTPUT POWER versus INPUT POWER

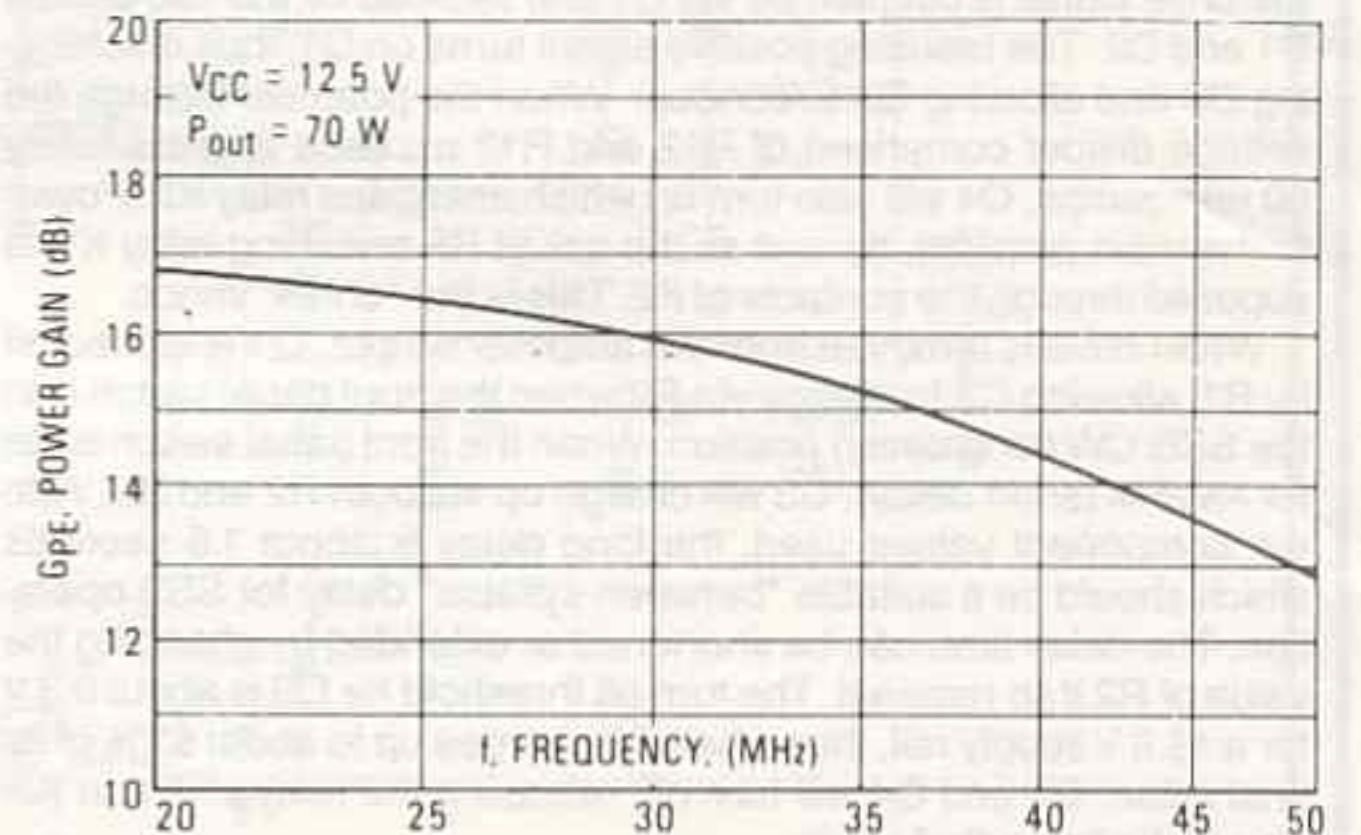

— POWER GAIN versus FREQUENCY

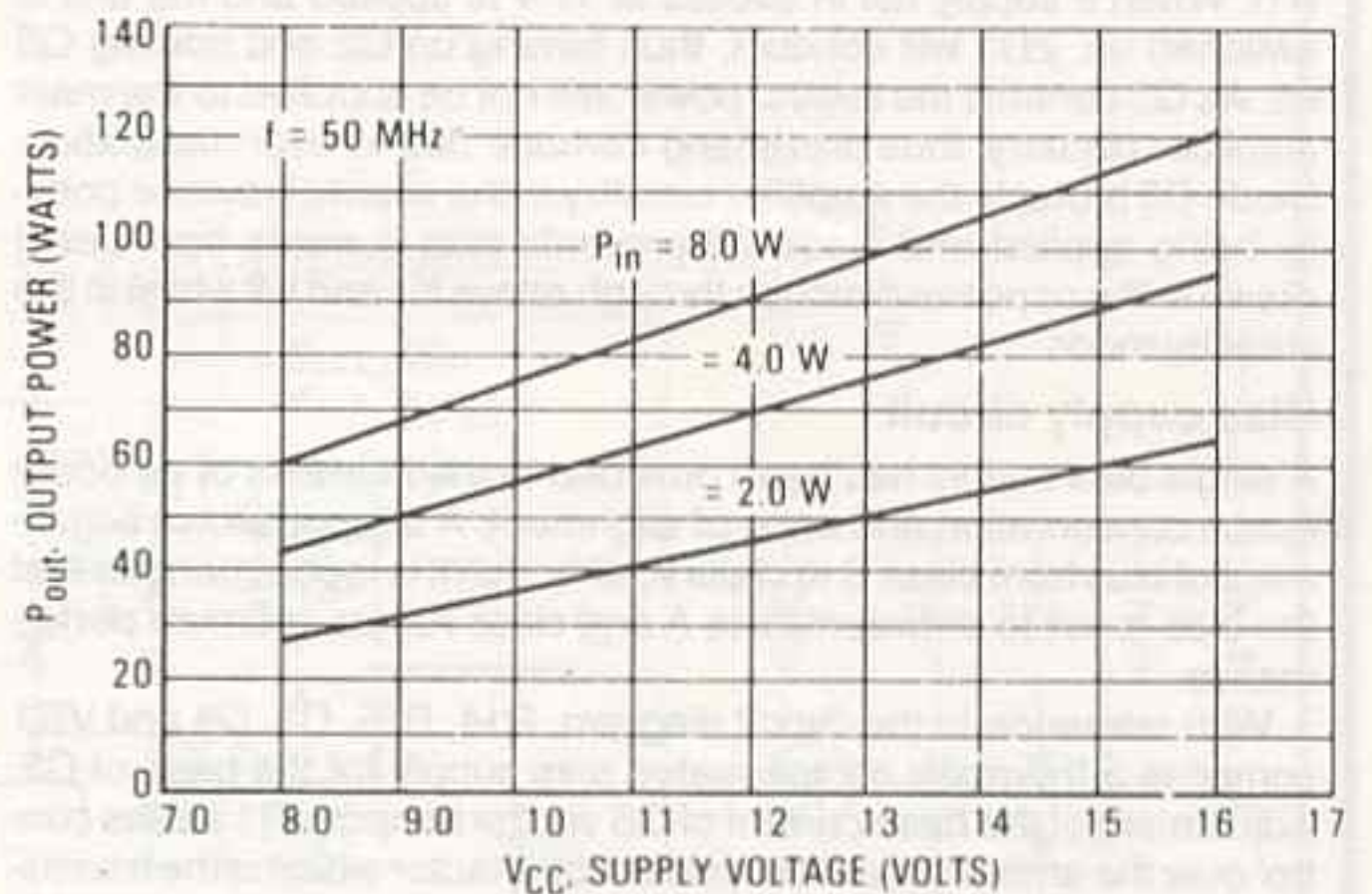

— OUTPUT POWER versus SUPPLY VOLTAGE

VC3-VC4 and VC5-VC6 for maximum power output. Next, you should adjust the input trimmers, VC1 and VC2 for minimum input VSWR. If your power meter and VSWR meter are one and the same instrument, you will have to remove it from the output and connect it in series with the input. Don't forget to re-connect the dummy load to the output.

Repeat these steps several times, this time aligning one "half" of the amplifier at a time and tuning the input stage first and output stage last, i.e: adjust VC1, VC3 and VC4, then VC2, VC5 and VC6. The output power should now be 20 to 30 watts, assuming a drive of one watt, and the current drawn from the supply should be about nine amps. The maximum input drive can now be applied and the amplifier stages aligned as above. Refer to the input attenuator section for the maximum allowable input drive levels. Reference can be made to the graphs to obtain the expected levels of performance.

An approximate increase of 0.5 dB in power gain can be achieved with a slight sacrifice in efficiency by adjusting the bias trimmer VR1 towards class A (counter clockwise). This operation can be performed whilst transmitting, but make only small adjustments at a time.

To complete the alignment procedure, adjust VR2 so that the front panel meter reads full scale when maximum power output is being delivered. The aluminium cover can now be fitted and secured by the six 3 mm x 8 mm machine screws and two #4 self-tappers. Fix the four self-adhesive rubber feet to the bottom of the cover and the amplifier is ready for on-air operations.

CIRCUIT OPERATION

The operation of the amplifier is best examined by breaking the circuit down into a number of individual parts. We will begin by describing some of the "peripheral" parts such as the COR and protection circuit, the bias supply, the harmonic filter and the output metering circuit.

The COR and over-voltage protection

When the unit is first powered up, C3 charges to the supply voltage via R2. When drive is applied to the amplifier's input, a small part of the drive signal is coupled off via C1 and rectified by the two diodes D1 and D2. The resulting positive signal turns on Q1, thus discharging C3 and allowing Q3 to conduct. When the potential through the voltage divider comprised of R12 and R13 exceeds approximately 60 microamps, Q4 will also turn on which energises relay K2. Power to the main amplifier, as well as the coil of RF switching relay K1, is supplied through the contacts of K2. This is the "on-air" mode.

When drive is removed from the amplifier's input, Q1 is biased off by R1, allowing C3 to charge via R2 when the front panel switch is in the SSB/CW (long delay) position. When the front panel switch is set for AM/FM (short delay), C3 will charge up via both R2 and R3. With the component values used, the long delay is about 1.5 seconds which should be a suitable "between syllable" delay for SSB operation. The delay time can be shortened or extended by changing the value of R2 if so required. The turn off threshold for Q3 is about 9.3 V for a 13.8 V supply rail, thus when C3 charges up to about 63% of its final value, Q3 and Q4 will turn off, releasing the relays K1 and K2. This is the "standby" mode.

An over-voltage sensing circuit is provided by Q2, ZD1, R10 and R11. When a supply rail in excess of 17 V is applied and the unit is switched on, ZD1 will conduct, thus turning on Q2 and holding Q3 off. As Q3 controls the relays, power will not be supplied to the main amplifier circuitry, thus preventing damage due to over dissipation. Diode D8 protects the amplifier circuitry in the event of reverse polarity being applied and diode D6 prevents bias currents from being drawn in the opposite direction through relays K1 and K2 whilst in the standby mode.

Bias supply circuit

A single bias supply has been provided in the interests of pc board space conservation and ease of alignment. A trimpot allows adjustment of bias from class B to class A, although it is recommended that the bias is set to between class A and class AB for optimum performance.

With reference to the circuit diagram, R14, R15, D3, D4 and VR1 comprise a thermally compensated bias supply for the base of Q5. Adjustment of the base current of Q5 via the trimpot VR1 allows control over the amount of emitter current by a factor which is the transistor's hFE. The actual amount of current through the emitter of Q5 is determined by the current requirements of Q6 and Q7.

Diodes D3 and D4 are mounted across their respective power transistors for thermal compensation. The 100 mA diode current affects the amount of compensation and will tend to "throttle back" the RF output power by between 0.5 dB and 1 dB from initial cold start, to continuous operation over a period of some minutes. Trimpot VR1 can be adjusted during transmission to swing the output power by plus or minus 0.5 dB. Resistor R16 limits the bias current to 350 mA, whilst the two chokes RFC4 and RFC5 isolate the bias circuitry from RF present on the bases of Q6 and Q7.

Optional input attenuator

With reference to the power-in/power-out graph, it can be seen that an appreciable deviation from the linear portion of the curve occurs just after 100 watts output. It would thus be desirable to limit the amplifier's maximum output to this level so that suitable linearity for SSB operation is retained. If a low power exciter of 2-3 W output is employed to drive the amplifier, it will never be driven beyond the 100 W level and an input attenuator will not be needed. This is also the case for higher power exciters which have the facility to vary their power output, but care should be taken not to exceed the amplifier's 100 W output level.

If a high power exciter of 10 W - 15 W output is to be used, some sort of attenuator will be required to prevent the amplifier from being driven into non-linearity. We will use the figure of 15 W drive to demonstrate how to calculate the values required for such an attenuator.

Referring again to the power-out/power-in graph, you will see that 100 W output will require a drive of 5 to 6 watts. To allow for variations in the gain of the MRF492s, we will assume a drive of 5 W. Now that you have established the drive-available and drive-required figures, the following formulae can be used to calculate the resistor values for a T-network attenuator:

$$Z = 50 \text{ ohms}$$

$$K = \sqrt{P_{out}/P_{in}}$$

$$= \sqrt{15/5}$$

$$= 1.732$$

$$R1 = R2 = Z[1 - 2/(K+1)]$$

$$= 50 \times 0.268$$

$$= 13.4 \text{ ohms}$$

$$R3 = \frac{2ZK}{K-1}$$

$$= \frac{2 \times 50 \times 1.732}{1.732 - 1}$$

$$= 86.6 \text{ ohms}$$

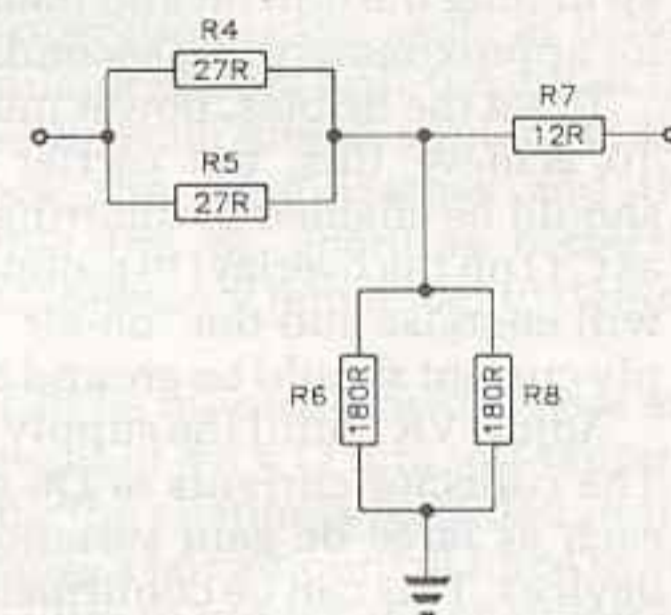
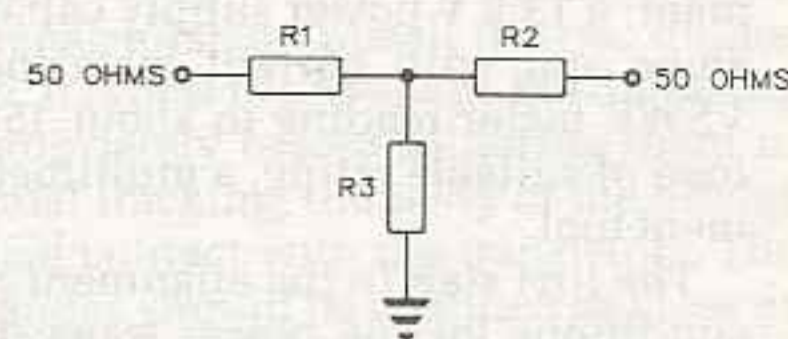

Giving consideration to the dissipation levels in each arm of the attenuator, the following configuration and values were chosen. All resistors are rated at 2 W and to minimise inductive effects, Allen Bradley hot moulded components were chosen.

In the case of the attenuator not being required, a link made from 1.7 mm tinned copper wire can be used and inserted in the LK1 position as indicated on the component overlay.

CAUTION! This amplifier is capable of delivering a saturated output of over 150 W when drive levels in excess of 12-14 W are applied without an attenuator fitted. Continuous operation under these conditions is almost certain to result in permanent damage to the power transistors and associated components due to over dissipation. The amplifier's output should be limited to a maximum of 120 W for safe continuous operation.

Harmonic filter

Before the harmonic filter was incorporated in the prototype unit, the second and third harmonics measured -25 dB and -55 dB respectively. The design specifications called for harmonics to be suppressed to better than -60 dB with respect to the carrier. To suppress the second harmonic would thus require a filter with a 40 dB/octave attenuation slope, allowing for construction tolerances. This could be easily achieved with a "Butterworth" response, but would require at least seven elements to obtain the desired attenuation result.

A "Chebychev" filter offers a faster initial rolloff for less elements and was chosen in the interests of conserving board space. Only five elements are required with the Chebychev arrangement to achieve a 40 dB/octave slope, and in this circuit these are L9, L10, C28, C29 and C30. The filter exhibits a characteristic passband ripple of only 0.1 dB.

After determining the component values and fitting the filter to the prototype, a new set of measurements was made. The second harmonic measured -63 dB whilst the third harmonic was better than -70 dB with respect to the carrier. Insertion loss and the 0.1 dB passband ripple were not evident on the plotted response graph of the filter.

RF output meter

The front panel meter is intended to give a relative indication of output power and is thus not suitable for absolute measurements. Whether in standby or amplify mode, a small portion of the output signal is tapped off by C31 and then rectified by diodes D9 and D10. The resultant dc signal is attenuated by R19 and R20 and filtered by C33 and C34. Trimpot VR2 allows calibration of the meter by limiting the current through the coil.

If the range provided by VR2 is not sufficient, the ratio of R19 and R20 can be adjusted to increase or decrease the sensitivity accordingly. You should be aware that the indication on the meter will alter if the amplifier is driven into loads that depart from a 50 ohm impedance.

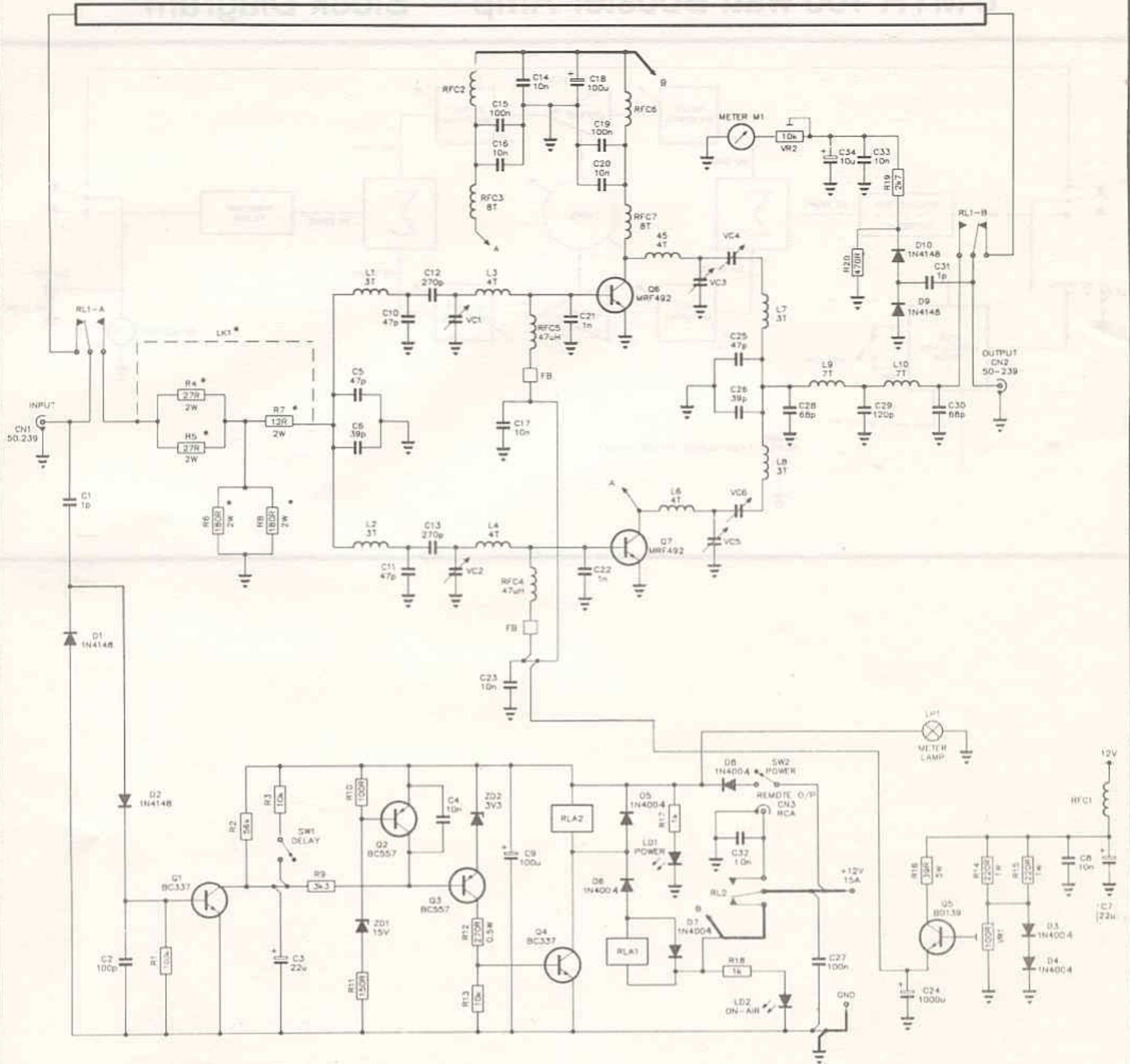

* See text on Page 6

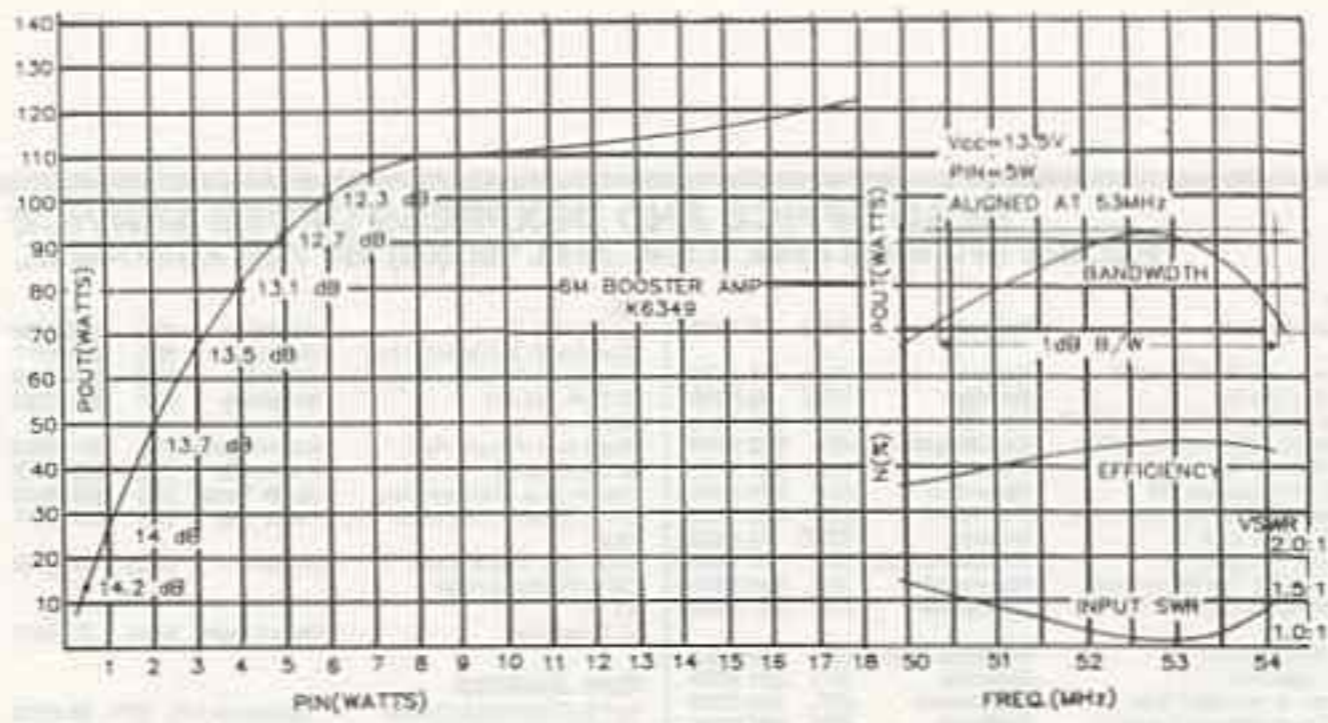

6 MTR 100 watt Booster Amp — Block Diagram

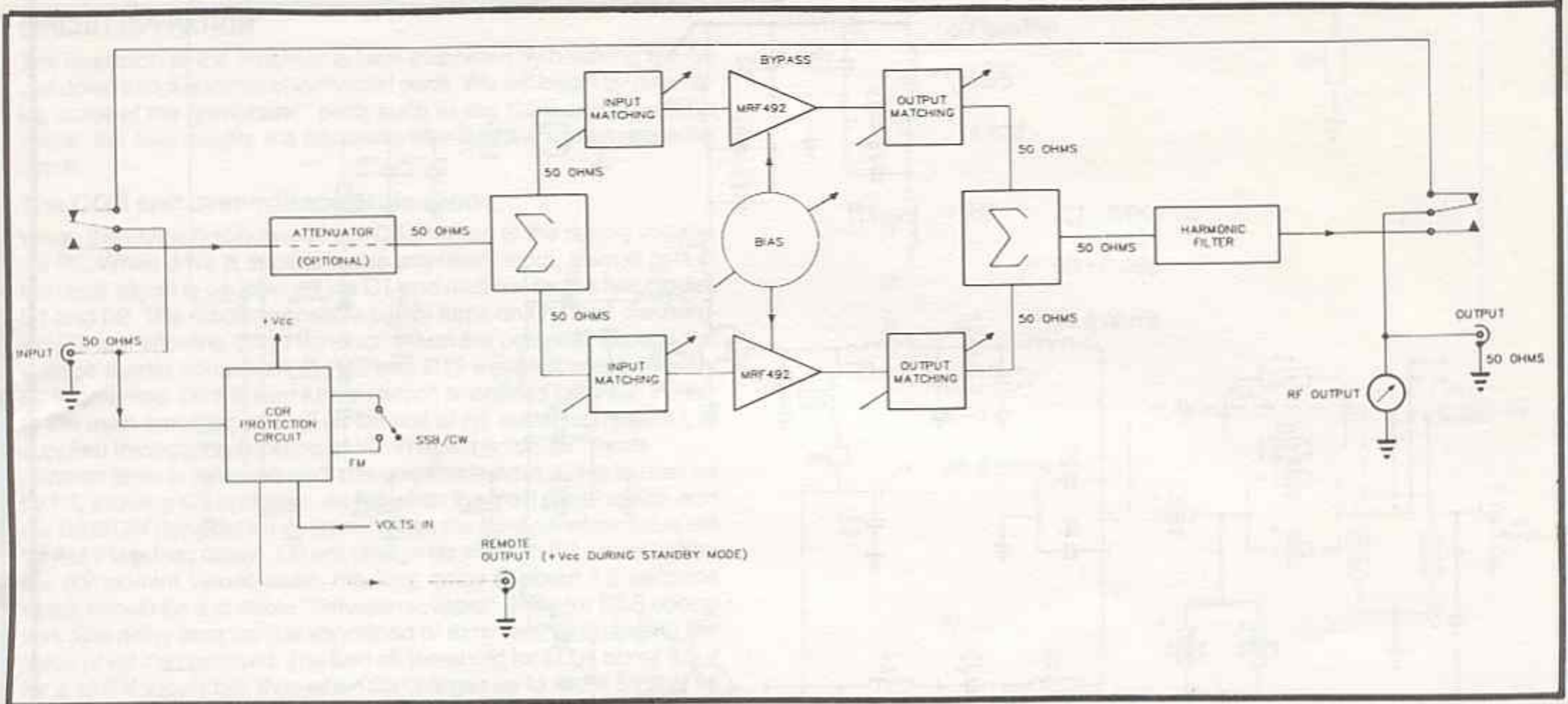

STORE LOCATIONS

HEAD OFFICE AND DSXPRESS ORDER SERVICE
P.O. Box 321, North Ryde, N.S.W. 2113. Tel: (02) 888 3200 AUSTRALIA.

Australia

NSW

Swift & Young Sts
155 Terrace Level
Shop 1, 65-75 Main St
613 Princess Hwy
Oxford & Adelaide Sts
531 Pittwater Rd
Campbelltown Mall Queen St
Shop 235, Archer St Entrance
147 Hume Hwy
164 Pacific Hwy
315 Mann St
4 Florence St
Elizabeth Dr & Bathurst St
450 High Street
621-627 The Kingsway
173 Maitland Rd, Tighes Hill
Lane Cove & Waterloo Rds
George & Smith Sts
The Gateway High & Henry Sts
818 George St
125 York St
Treasurer's Bldg, Brisbane St
263 Keira St

Albury (060) 21 8388
Bankstown Sq (02) 797 4888
Blackburn (02) 871 7722
Blackhurst (02) 548 7744
Bondi Junction (02) 387 1444
Brookvale (02) 83 0441
Campbelltown (048) 27 2188
Chatswood Chase (02) 411 1955
Chullora (02) 642 8922
Gore Hill (02) 439 5311
Goferd (043) 25 0235
Horsham (02) 477 6833
Liverpool (02) 600 8888
Maitland (049) 33 7888
Miranda (02) 525 2722
Newcastle (049) 81 1896
North Ryde (02) 88 3855
Parramatta (02) 889 2188
Penrith (047) 32 3400
Railway Square (02) 211 3777
Sydney City (02) 287 9111
Tamworth (067) 88 1711
Wollongong (042) 28 3800

ACT

95 Gladstone St
VIC
Creswick Rd & Woodlee St
145 McCrae St
Shop 46, Box H8 Central Main St
Hawthorn Rd & Nepean Hwy
260 Sydney Rd
1150 Mt Alexander Rd
Nepean Hwy & Ross Smith Ave
Shop 9 110, High St
291-293 Elizabeth St
Bridge Rd & The Boulevard
Springvale & Dandenong Rds
QLD
157-159 Elizabeth St
166 Logan Rd
Gympie & Hamilton Rds
2nd Level Western Entrance
Redbank Shopping Plaza
Queen Elizabeth Dr & Berrard St
Gold Coast Hwy & Welch St
Bowen & Rutledge Sts
Kings Rd & Woodcock St
Cnr Pacific Hwy & Kingston Rd

Fyshwick (062) 80 4844
Ballarat (053) 31 5433
Bendigo (054) 43 0388
Box Hill (03) 890 0899
East Brighton (03) 592 2386
Coburg (03) 383 4455
Essendon (03) 378 7444
Frankston (03) 783 9144
Geelong (052) 43 8522
Melbourne City (03) 87 9834
Richmond (03) 428 1614
Springvale (03) 547 0522
Brisbane City (07) 229 9377
Buranda (07) 391 8233
Chermside (07) 358 8255
Redbank (07) 288 5599
Rockhampton (079) 27 9644
Southport (075) 32 9883
Toowoomba (076) 38 4300
Toowoomba (077) 72 5722
Underwood (07) 341 0844

SA

77 Grenfell St
Main South & Flagstaff Rds
Main North Rd & Darlington St
24 Park Terrace
WA
Wharf St & Albany Hwy
56 Adelaide St
William St & Robinson Ave
Raine Square, 125 William St
TAS
Shop 40A, Lower Level
Cnr Fiddle Arcade
NT
17 Stuart Hwy
New Zealand
Fort & Commerce Streets
1795 Great North Road
Victoria Road & Seresley Avenue
Manse & Stafford Streets
450 Anglessea Street
447 Cuba Street, Alletown
Cnr Khyber Pass & Park Rds
26 East Tamaki Road

Adelaide (08) 232 1200
Darlington (08) 288 8977
Enfield (08) 280 6088
Salisbury (08) 281 1583
Cannington (09) 451 8888
Fremantle (09) 335 9733
North Perth (09) 328 8944
Perth City (09) 481 3281
Hobart (002) 31 0800
Stuart Park (089) 81 1977

USA

16 Lydney Place
289 Cameron Road
154 Featherston Street
Portlaura
Tauranga
Wellington
(07) 37 6654
(075) 87 071
(04) 73 9558
Berkeley, Calif (415) 486 0755
Los Angeles, Calif (213) 474 0628
Redwood City, Calif (415) 306 8844
San Jose, Calif (408) 241 2366
2474 Shattuck Avenue
1830 Welwood Boulevard
390 Convention Way
4980 Stevers Creek Boulevard
DICK SMITH ELECTRONICS
PTY LTD
Terms available to approved personnel
applications through
AOC **MasterCard** **WELLS FARGO** **VISA**