

The Galaxy 2000+ Linear Amplifier is a compact table-top affair.

*CQ* Reviews:

## The Galaxy 2000+ Linear Amplifier

BY WILFRED M. SCHERER,\*  
W2AEF



**T**HE Galaxy 2000+ Linear Amplifier is a table-top affair designed for use with a 100-watt output exciter to provide a p.e.p. input of 2000 watts on s.s.b. and the maximum legal input of 1000 watts for c.w. and RTTY on the 80 through 10 meter amateur bands. It is a compact and moderately-priced unit made possible by the use of TV horizontal-deflection tubes operated with a plate potential of only 800 volts.

The setup consists of two units: the amplifier which measures only 6"  $\times$  10 $\frac{1}{4}$ "  $\times$  11 $\frac{1}{2}$ " (H.W.D.) and a power supply that is 7"  $\times$  9 $\frac{1}{2}$ "  $\times$  7 $\frac{1}{2}$ " (H.W.D.) and which weighs only 30 lbs, making it easy to cart around.

### Technical Details

Referring to fig. 1, ten parallel-connected type 6HF5 tubes in grounded-cathode circuitry are used in the amplifier. The grid-input circuit is untuned with the r.f. input connected directly through to the tube grids which are shunted with  $R_1$ , a 50-ohm non-inductive 100-watt Globar resistor, that presents the proper load to the driver and ensures good regulation. On 10 and 15 meters the input capacitive reactance of the tubes becomes significant, so for these bands  $S_1$ , (which is linked to the bandswitch), closes and shunt-connects  $L_1$  to counteract the tube reactance. Since the grid circuit is heavily swamped by the 50-ohm resistor, stability at the operating frequency is obtained without neutralization. Parasitic oscillations are avoided with a suppressor installed in the plate lead to each tube.

The output circuit consists of an adjustable Pi-network for matching to loads of 40-90 ohms. Use of the large number of parallel-connected tubes, operating with low plate voltage and high current, requires a very low-impedance plate load. A conventional Pi configuration would then have to be a very high-C affair with an abnormally small value tank inductor and unusually large variable capacitors for tuning and loading over the whole range of the lower-frequency bands. In addition, the coil would have to be wound with a larger size conductor than usual

in order to keep down losses and the extra heat that would be introduced as a result of higher circulating current due to the low circuit impedance. An inductor of impractical physical proportions would then be needed, as well as heavier switch contacts.

In order to avoid these consequences, a higher-impedance tank circuit is used in the Galaxy 2000+ and the proper plate load is obtained by connecting the tubes across a lower-impedance portion of the circuit. This is accomplished using a capacitive divider consisting of  $C_1$  and  $C_2$  in an arrangement similar to the familiar one often employed for matching a low-impedance line to the input or output of a receiving converter. The principle is the same as tapping an inductor for the desired impedance point.

$C_1$  and  $C_2$  are ganged together using a multi-section variable capacitor and thus constitute the plate-tuning capacitance for the Pi-circuit while maintaining the matching-impedance ratio at the same time.

$R_1$  connected across  $C_2$  is a simple and inexpensive protective measure that drains off the charge across the relatively large size coupling capacitor. Also, since the resistance of  $R_1$  is low, compared to the leakage reactance of the coupling capacitor, it thus prevents high voltage from appearing on the capacitor rotor shaft to which the tuning knob is attached. Then too, it minimizes the possibility of voltage breakdown across the capacitor, permitting the use of moderate capacitor-plate spacing.

### Linearity Control

Non-linearity is often an inherent problem when more than one tube is used in a linear amplifier, because of the difficulty in obtaining perfectly matched tubes that each have identical gain at all power levels. In order to counteract this situation the Galaxy 2000+, which employs a large number of tubes normally operating in class  $AB_1$ , incorporates a compensating bias-regulating system designed to automatically maintain linearity at various power levels and thereby minimize distortion products.

Operation of the linearity-control system is as follows: samples of the r.f. input and output volt-

\*Technical Director, *CQ*.



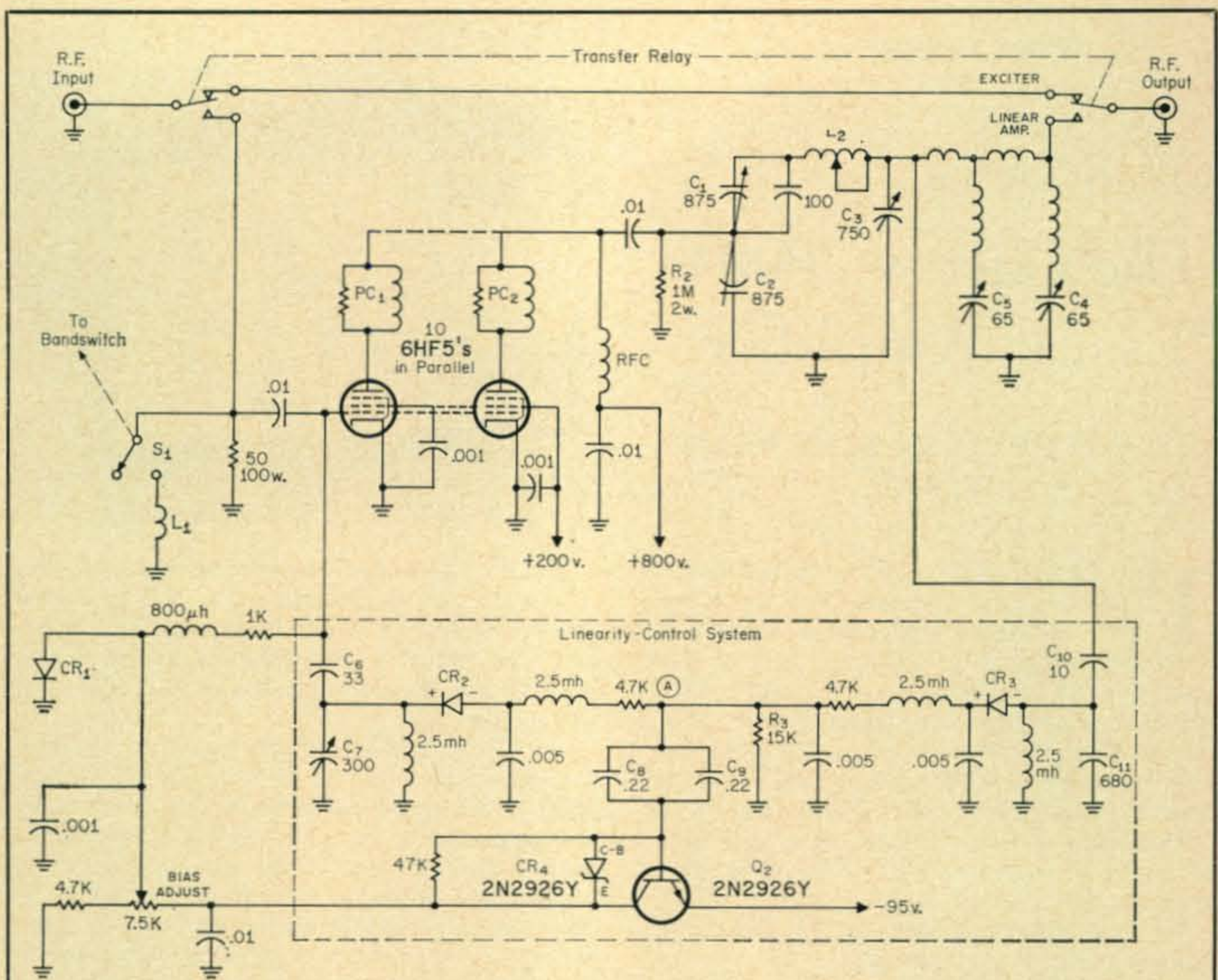

Fig. 1—Basic circuitry for the Galaxy 2000+ Linear Amplifier. The low-impedance plate load for the tubes is obtained by tapping the Pi-output circuit at the proper impedance point which is located at the junction of  $C_1$  and  $C_2$ . The maximum capacitance values are shown for 10 meters. Additional capacitors are switched in for the lower frequencies. For 80 meters a maximum capacitance of 1275 mmf is

used at  $C_1$ , 1175 mmf at  $C_2$  and 2400 mmf at  $C_3$ . The bandswitch also selects various taps on  $L_2$ . The adjustable t.v.i. filter is comprised of  $C_4$ - $C_5$  and the associated inductors. Operation of the linearity-control system is explained in the text. Should an arc-over occur in the tubes,  $CR_1$  will conduct and provide a direct path to ground, thereby protecting  $Q_1$  from damage and avoiding possible loss of bias.

ages, obtained from the capacitive dividers  $C_6$ - $C_7$  and  $C_{10}$ - $C_{11}$ , are rectified by  $CR_2$  and  $CR_3$ . With the amplifier operating at maximum steady-state power,  $C_7$  is factory-adjusted so the rectified voltages are equal and zero voltage thus appears at point  $A$ , because the rectifier outputs are of opposite polarity.

When non-linearity tends to occur during modulation, the instantaneous r.f. input and output voltages each vary by a different relative amount and thus produce a net voltage difference at  $A$ . This voltage, which will vary at an audio rate, is then applied to the base of  $Q_1$  which functions as a series regulator in the bias-supply line. The bias is thereby shifted toward operation in the class-A region where distortion can be reduced during the required portion of the modulating cycle.  $CR_1$  is a diode-connected transistor that functions as a regulator to limit the bias shift toward class-A operation to about 9 volts.

#### Antenna Transfer

The r.f. input and output circuits are wired through a transfer relay that permits straight-

through operation using the exciter alone or operation with the linear amplifier. With the latter, the antenna is transferred back to the r.f. input side during receive to permit reception with a transceiver type of exciter unit.

#### Harmonic Filter

A feature of the Galaxy 2000+ is the built-in low-pass t.v.i. filter that is designed to attenuate all frequencies above 40 mc. It is a two-section  $M$ -derived type in which the shunt-connected series-resonant arms are adjustable for maximum attenuation on two particular TV channels. The factory settings are for maximum rejection on channels 3 and 6, but if necessary,  $C_4$  may be adjusted for maximum protection of one of the channels between 2 and 5.  $C_5$  may be set for a channel between 6 and 13. The capacitors are accessible for screw-driver adjustment through holes in the side of the cabinet.

Further precautions against t.v.i. have been made by suitable bypassing of all power and control leads at their input or output terminals where additional measures are taken by forming



the leads into small r.f. chokes. The panel meter also is bypassed and shielded.

### Power Supply

Silicon rectifiers are used in the power supply. The single power transformer has three secondary windings. One supplies  $-75$  v.d.c. obtained through a half-wave rectifier. A tap on the winding supplies 63 v.a.c. for the tube heaters which are wired in series to hold the current drain down to that required for only one tube: 2.25 amperes.

200 volts d.c. is obtained from the second winding using a bridge-rectifier configuration. The negative end is grounded. The third winding, also using a bridge rectifier, furnishes 600 v.d.c. For s.s.b. operation a jumper plug is inserted in a receptacle at one side of the power unit, marked s.s.b. This then connects the *positive* side of the 200-volt supply to the *negative* side of the 600-volt supply, placing the two sources in series to furnish a total of 800 volts plate potential. A screen potential of 200 volts is obtained at the series connection.

For c.w. and RTTY the plug is moved over to another receptacle, marked CW/RTTY, which then breaks the series connection and connects the positive side of the 200-volt source through a small voltage-dropping resistor to only the supply line for the tube screens. At the same time the negative end of the 600-volt source is grounded and the available plate potential is only 600 volts to limit the plate input to the maximum legal limit.

Excellent dynamic voltage regulation is obtained using four electrolytic capacitors, connected in series-parallel, that provide 300 mf of filter capacitance, a considerably higher value

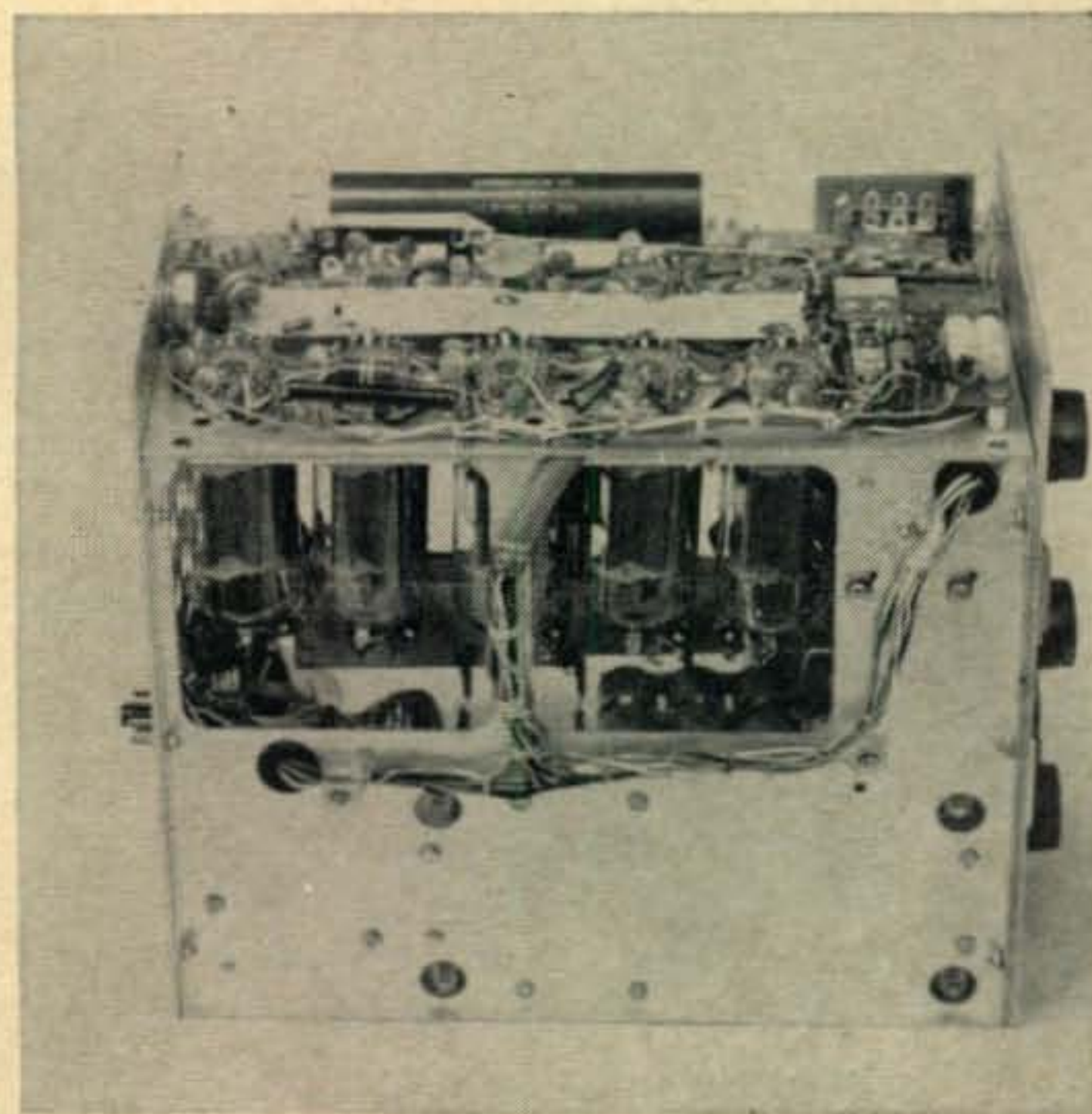

Bottom and side view of the Galaxy 2000+. The large square cutouts permit good air circulation for ventilating the tubes visible in the openings. A printed-circuit board with the Linearity-Control system is at the right above the feedthrough grommet for the harness. The wide strip that traverses the tube sockets is the low-inductance bus for connecting the grids in parallel. The 50-ohm 100-watt Globar-type input-terminating resistor is at the top.

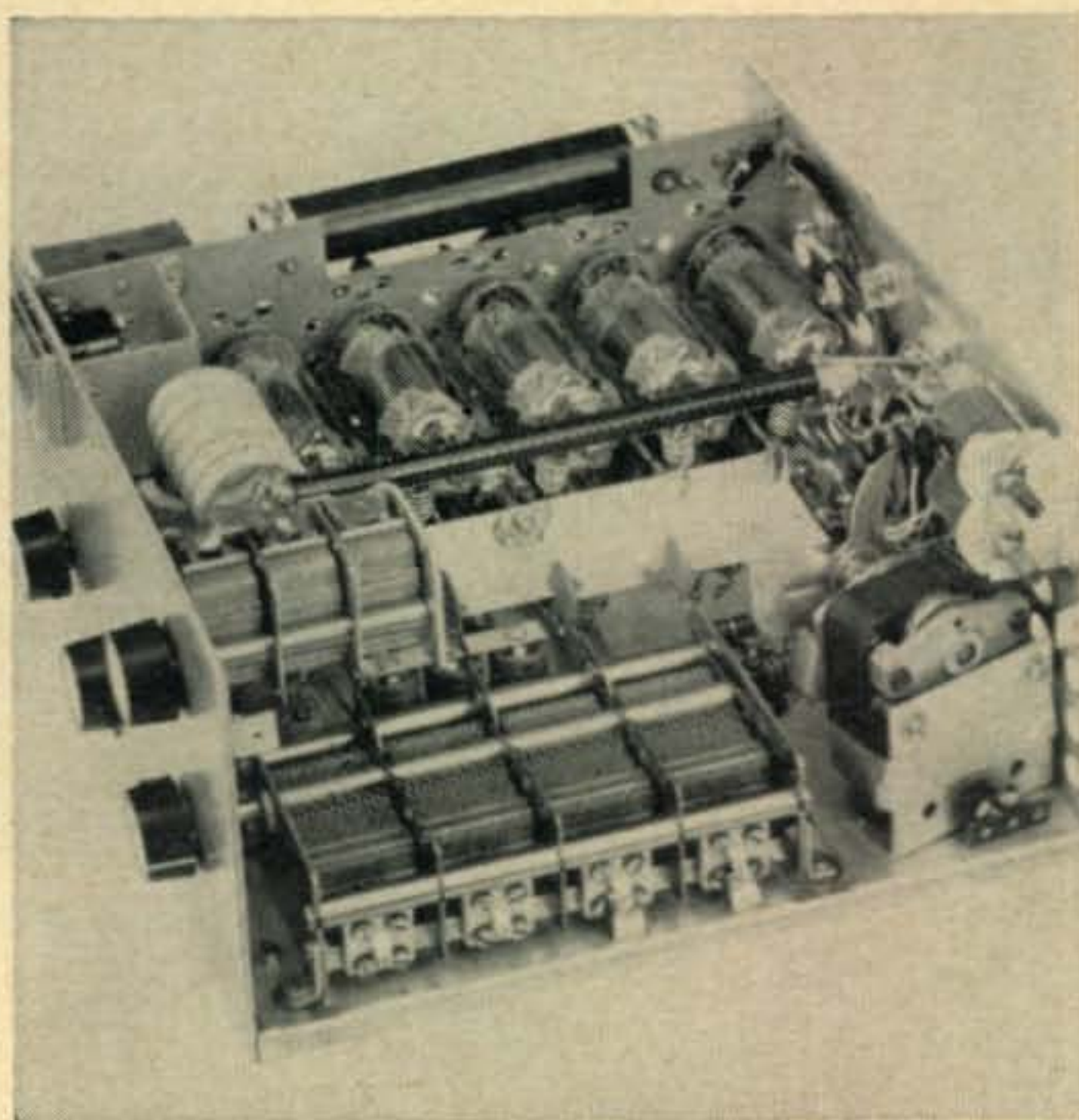

Interior view of the Galaxy 2000+. The ten tubes are mounted in two rows of five each. Only the top row is visible. Each tube plate is connected with an individual parasitic suppressor to the wide strip, shown at the center, which is a low-inductance plate bus. The 10-15 meter section of the output tank is the tubing-wound coil near the upper left. The three-section variable capacitor is the output-loading, the four-section job below it is the plate-tuning. The blower is at the lower right, above it is the adjustable t.v.i. filter.

than would be practical with low cost if the customarily higher voltages were involved. Two paralleled capacitors furnish 600 mf for the lower-voltage source.

Peak plate currents run in the vicinity of 2.5 amperes, so although it is relatively small, the transformer is quite husky, wound with heavier-than-usual wire. Two primary windings may be connected in parallel or series for 115 or 230 v.a.c. operation respectively. The maximum total primary-current requirements with 115 volts runs near 20 amperes and 10 amperes with 230 volts. For best line-voltage regulation a 230 volt source is recommended. A 10 ampere fuse in one leg of each primary winding offers equal protection with either 115 or 230 volt operation.

### Construction

In the amplifier open framework type of construction is used, supported between the front and rear panels. The portion of the tank inductor used for 10 and 15 meters is wound with  $\frac{1}{4}$ " diameter silver-plated tubing. The low-frequency section utilizes #14 wire. Also silver plated are wide strips used as a common low-inductance bus for paralleling the plate and grid connections to the tubes. Individual disc-ceramic by-passes for the screens and heaters are installed directly at each of the ten tube sockets.

The t.v.i. filter inductors are air-wound with #16 wire and their associated trimmer capacitors are the APC type. The output loading capacitor is a conventional size 3-gang type, while the plate tuning/impedance-divider capacitor is a large 4-section job with its frame mounted on lucite strips to insulate the rotor from ground.





Power Supply for the Galaxy 2000+. The jumper plug is in the s.s.b. position.

Pairs of sections are connected in parallel.

The amplifier is housed in a metal case liberally perforated all around to provide adequate ventilation and cooling which is augmented by a small blower fan within the unit. The styling matches that of the Galaxy line of exciters.

The power supply is built on a chassis with a removable top cover. An interconnecting power cable plugs into the amplifier and is about 5 feet long, allowing placement of the unit in a convenient out-of-the-way location.

### Operation

A function switch controls the a.c. power and sets up the equipment for tuneup or normal operation. In the tuneup position, the screen voltage is reduced to maintain a lower power input that prevents off-resonance damage and holds the power within the maximum legal steady-state value.

At tuneup the panel meter reads plate current and a specific point is marked for the reading that indicates proper tuning which is accomplished using the plate and loading controls. No grid-input tuning is needed. Full-power operation is set up when the switch is set for the meter to indicate either plate voltage or current. An unusual sight on amateur gear is that the plate-current calibrations are in *amperes!* When a.c. power is applied to the tube heaters on standby, a yellow light goes on. A red lamp lights when plate power is applied.

### Performance

The amplifier tunes up very simply and easily. When adjusted to the TUNE mark on the meter, the input ran about 700 watts, allowing a good safety margin. Changing over to OPERATE and applying a carrier or single-tone drive of 100 watts, the d.c. plate input amounted to 1700 watts with an output of 1100 watts on all bands (with 230 volts, under full load, measured on the power line). Due to the excellent dynamic voltage regulation, the p.e.p. input with voice modulation ran a bit over 2000 watts and the p.e.p. output was 1300 watts, while at the same

time the panel-meter peaks read *within* the legal 1 kw limit. This point, by the way, is the one marked TUNE on the meter.

Actually, full peak output was obtained with an average meter swing of less than 1 kw, depending on the voice and microphone characteristics. In any event, continuously kicking the meter to the indicated point will result in flat-topping, especially since there is no a.l.c. Optimum operating levels for the cleanest signal are therefore best checked using an oscilloscope.

The 6HF5's apparently are well suited to take the gaff, inasmuch as at no time did the tube plates show color or exhibit other indications of excessive heating or any deterioration, even during prolonged tests with steady-state or two-tone power.

Linearity checks were made with and without the linearity-control system in operation. Oscilloscope observations indicated its effectiveness in straightening out the input/output characteristics, particularly at the knee of the curve. With the system in use the 3rd-order distortion measured just about to the rating of -30 db, as compared to -22 db without it.

The automatic linearity-control system really pays off as may be seen from the two-tone test patterns in the photographs.

The s.w.r. between the exciter and the amplifier input was under 2:1, except on 20 and 10 meters it was 3:1 and 4:1 respectively.<sup>1</sup> If the exciter does not have an adjustable output-impedance matching arrangement to handle this range, some difficulty may be found in obtaining adequate drive for the linear amplifier.

With the power-supply jumper plug in the c.w./RTTY position and with 1 kw input to the amplifier, the r.f. output was 600 watts for these modes of operation. Loading to higher than 1 kw gains nothing; in fact, the power output goes down.

Although the protective measure using  $R_1$  is included, as described previously, we'd like to point out that the high-value filter capacitors discharge very slowly after power is removed (requiring 1-2 minutes). Therefore, if it is necessary to do any service work on the equipment, first disconnect the power-cable from the amplifier or discharge the capacitors by using a screwdriver with an insulated handle to short one of the tube plates to the chassis. If work is to be done on the power supply, similarly discharge each capacitor in the unit.

The Galaxy 2000 Linear Amplifier is priced at \$450.00, complete with all tubes and the companion power supply. A replacement set of all ten tubes is priced at \$29.95. The equipment is produced by Galaxy Electronics, 10 South 34th Street, Council Bluffs, Iowa 51504. —W2AEF

<sup>1</sup>As found using the 34-inch cable supplied with the amplifier. Proper tuning requires a full input of 100 watts. If this cannot be attained with the existing s.w.r. while using an exciter with a fixed or limited output-impedance range, the input cable will have to be lengthened (as determined experimentally) for a reflected impedance that will permit correct loading of the exciter.