



**COMMANDER HF-2500
COMMANDER HF-2500 MAGNUM**

Owner's Manual



PALSTAR, INC.
Command Technologies Division
9676 N. Looney Road
Piqua, Ohio 45356
U.S.A.

Customer Service and Sales Telephone: 800-773-7931
International: 937-773-6255
Fax: 937-773-8003
E-mail: info@palstar.com

Table of Contents

Introduction	3
Specifications	4
Unpacking Instructions	5
Vacuum Tube Installation	5
HV Transformer Installation	6-8
Safety Warnings and Precautions	9
Connections	10
Rear Panel View	11
Front Panel View & Tuning Procedure	12
Theory of Operation & Adjustments	14
Warranty, Service, and Returns	16
RF Deck View	17
HF-2500 HV Power Supply Schematic	18
Access Plate Illustration	19
MAGNUM HV Power Supply Schematic	20
AC Mains & Step-Start Schematic	21
Control Board Schematic	22
Tuned Input & T/R Switch Schematic	23
RF Deck Schematic	24
Amplifier Test Card	25
<u>PHOTO APPENDIX:</u>	
Dual Meters Diagram	26
Meter Board	27
Step-Start Board	28
Power Supply	29

Introduction

The Commander HF-2500 and Commander HF-2500 MAGNUM are class AB₂ linear power amplifiers. They have been designed for operation on all amateur frequencies from 1.80 MHz to 29.7 MHz, excluding the 30 meter band.

Two Eimac 3CPX800A7 pulse rated ceramic-metal triodes configured in a grounded grid circuit allow for conservative operation at 1500 watts continuous carrier output. A pressurized forced air cooled chassis, including the high voltage supply insures cool operation with high duty cycle emission modes.

The output circuit utilizes extra heavy duty components with vernier reduction drives on all tuning controls. Easily accessed rear panel controls allow for operator adjustment of input VSWR and ALC.

An automatic time delay circuit, insures proper cathode conditioning before RF drive can be applied. A protective circuit shuts down the amplifier in the event of excessive grid current. A resistor located in the high voltage B+ circuit protects the tube in the event of an internal tube arc. Metering function includes plate voltage, plate current, grid current and relative output.

Specifications

COMMANDER HF-2500/HF-2500 MAGNUM HF Linear Power Amplifier

- **Band Coverage:** 160, 80, 40, 20, 17, 15, 12, and 10 meter amateur radio bands.
- **Types of Emissions:** SSB, FM, CW, AM, RTTY, SSTV.
- **Driving Power Required:** 20 to 60 Watts nominal at rated continuous carrier output.
- **Maximum Output Power:** 1500 Watts Continuous Carrier.
- **Duty Cycle:** 100 percent in Amateur service at 1500 watts output power
- **Input impedance:** 50 Ohm unbalanced
- **Output Impedance:** 50 Ohm unbalanced: SWR 2:1 or less
- **Harmonic Suppression:** Exceeds all FCC requirements
- **Keying:** Requires contact closure of sinking +5 VDC at 15 mA.
- **Metering:** Plate voltage, plate current, grid current, and relative power
- **A.L.C.:** Negative going, adjustable from rear panel
- **Front Panel Controls:** Plate metering switch; On/Off switch; Standby/Operate switch; Tune; Load; Band selector switch.
- **Rear Panel Controls:** Tuned input adjustment; ALC adjustment; RF input; RF output; ALC output; Keying; ground connection; AC power inlet.
- **Tube Complement:** Two Eimac 3CPX800A7 pulse rated ceramic/metal triodes.
- **Cabinet Size:** 18.25" W x 8.5" H x 20.75" D (46.3cm x 21.6 cm x 52.7 cm)
- **Power Requirement:** 200/234 VAC, 50/60 Hz, 20 Amperes

UNPACKING

Carefully remove the Commander HF2500/HF-2500 MAGNUM Amplifier from its shipping carton making sure there is no damage evident from shipping. If there is any damage, notify the delivering shipper immediately, fully describing the damage.

The HV power transformer was shipped separately, as its weight would damage the cabinet in transit.

Do not destroy the packing material since it may be reusable later, should you require factory service or need to transport the Amplifier for any other reason.

TRANSFORMER INSTALLATION

Remove the top cover from the amplifier chassis. Install the transformer following the illustrated procedure beginning on next page (page 6).

SHIPPING BLOCK

The 3CPX800A7 tubes are shipped installed in the amplifier, held in place by a Styrofoam block. Remove the block before use.



200/234 VAC Operation

The Commander HF2500/HF-2500 MAGNUM come factory wired for 234 VAC operation. For best operation, you should use a dedicated 234VAC main capable of supplying 20 Amps of peak AC current.

Commander Amplifiers manufactured for export are wired for 234 VAC or 200 VAC depending on the final destination.

6



HF-2500 Transformer Installation Procedure

Here is the transformer and its mounting screws



Lift the transformer into amplifier chassis



Position the transformer over the mounting holes in the chassis and insert the provided 1/4-20 Phillips head screws through the transformer mounting tabs and into the threaded inserts in the chassis plate and tighten.

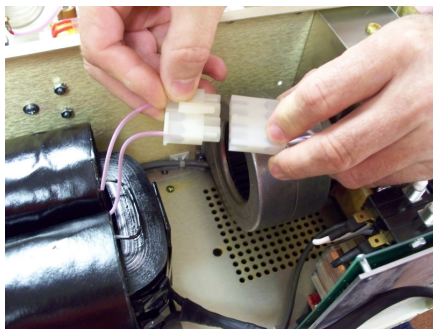

Plug the connector on the transformer into the mating one on the wiring harness. It is keyed so that it cannot be plugged in backwards. Make sure that the connector halves are pressed together until the lock tabs snap in place.

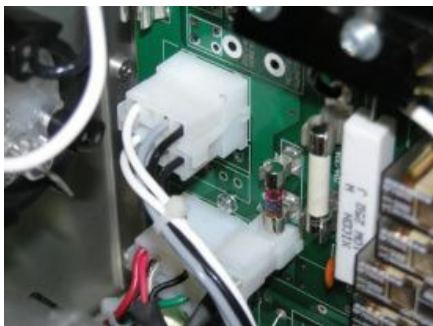

Plug the second connector on the transformer into the mating one on the AC Mains PCB. It is keyed so that it cannot be plugged in backwards. Make sure that the connector is pressed in until the lock tabs snap in place. Re-install top cover.

This completes HF-2500 transformer installation.

HF-2500 Magnum Transformer Installation Procedure

7



Here is the transformer and its mounting screws



Lift the transformer into amplifier chassis



Position the transformer over the mounting holes in the chassis and insert the provided 1/4-20 Phillips head screws through the transformer mounting tabs and into the threaded inserts in the chassis plate and tighten.

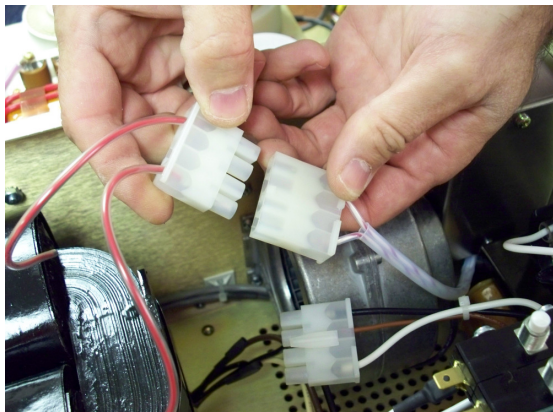

Plug the first connector on the transformer into the mating one on the chassis wiring harness. It is keyed so that it cannot be plugged in backwards. Make sure that the connector halves are pressed together until the lock tabs snap in place.

8

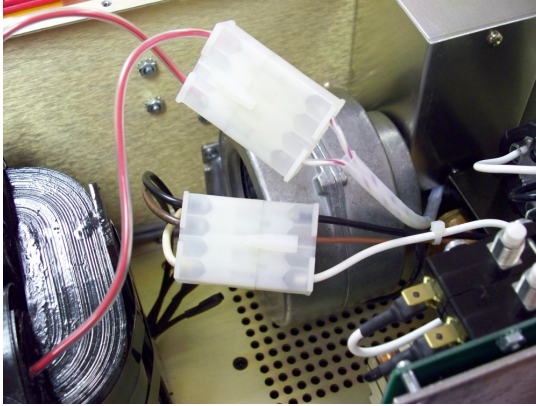

Plug the second connector on the transformer into the mating one that comes from the AC control board. It is keyed so that it cannot be plugged in backwards. Make sure that the connector halves are pressed together until the lock tabs snap in place.

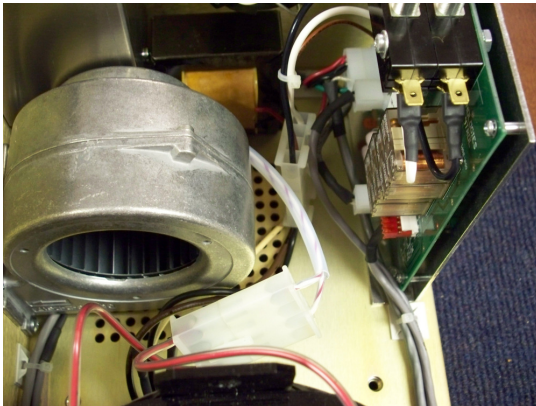

Dress the wires and connectors down out of the way

This completes HF-2500 Magnum transformer installation.

!! WARNING !!

CONTACT WITH VOLTAGES IN THIS AMPLIFIER CAN BE

!!! FATAL!!!

CAUTION:

- DO NOT attempt any type of service or repair on this amplifier without first removing the AC power and allowing **AT LEAST 10 MINUTES FOR THE HIGH VOLTAGE CAPACITORS TO BLEED OFF !**
- DO NOT operate this amplifier with the top or bottom covers removed. **THE VOLTAGES INSIDE THE CABINET ARE DEADLY ! EXPOSURE TO UNSHIELDED RF AT THESE POWER LEVELS IS HAZARDOUS TO YOUR HEALTH !**
- Never attempt operation without first connecting your amplifier to an appropriate antenna or dummy load. The antenna SWR should not exceed 2:1. The dummy load should have an impedance of 50 Ohms with sufficient power handling capability. **DAMAGE TO THE AMPLIFIER MAY RESULT IF OPERATED WITHOUT A CONNECTION TO A PROPER LOAD.**
- **NEVER OPERATE THIS AMPLIFIER WITHOUT AN EARTH GROUND CONNECTED TO THE REAR PANEL GROUND TERMINAL.**
- Do not obstruct the ventilation holes located on the top, bottom, and sides of the cabinet. These holes provide sufficient intake and exhaust of cooling air. **SEVERE OVERHEATING AND SERIOUS DAMAGE WILL RESULT IF SUFFICIENT VENTILATION IS NOT PROVIDED.**
- Never operate any amplifier using an extension cord.

Connecting Your Amplifier

- Connect the RF output of your transceiver to the RF Input connector on the rear of the HF-2500/HF-2500 MAGNUM with 50 Ohm coaxial cable.
- Connect the existing station antenna tuner or a Wattmeter and dummy load to the RF Output connector on the HF-2500/HF-2500 MAGNUM with RG-8 or better coaxial cable.
- Connect the Keyline jack on the rear of the HF-2500/HF-2500 MAGNUM to the normally open terminal of the relay jack on your transceiver. The Key jack on the HF-2500/HF-2500 MAGNUM has positive 5 VDC open circuit and requires the sinking of 15 mA of current when pulled to ground.
- Connect as short a ground lead as possible from a good RF ground to the Ground Post on the HF-2500/HF-2500 MAGNUM.
- Connect the ALC phono jack to the ALC connection on your transceiver using a shielded cable. Consult your transceiver manual for proper ALC connection details.

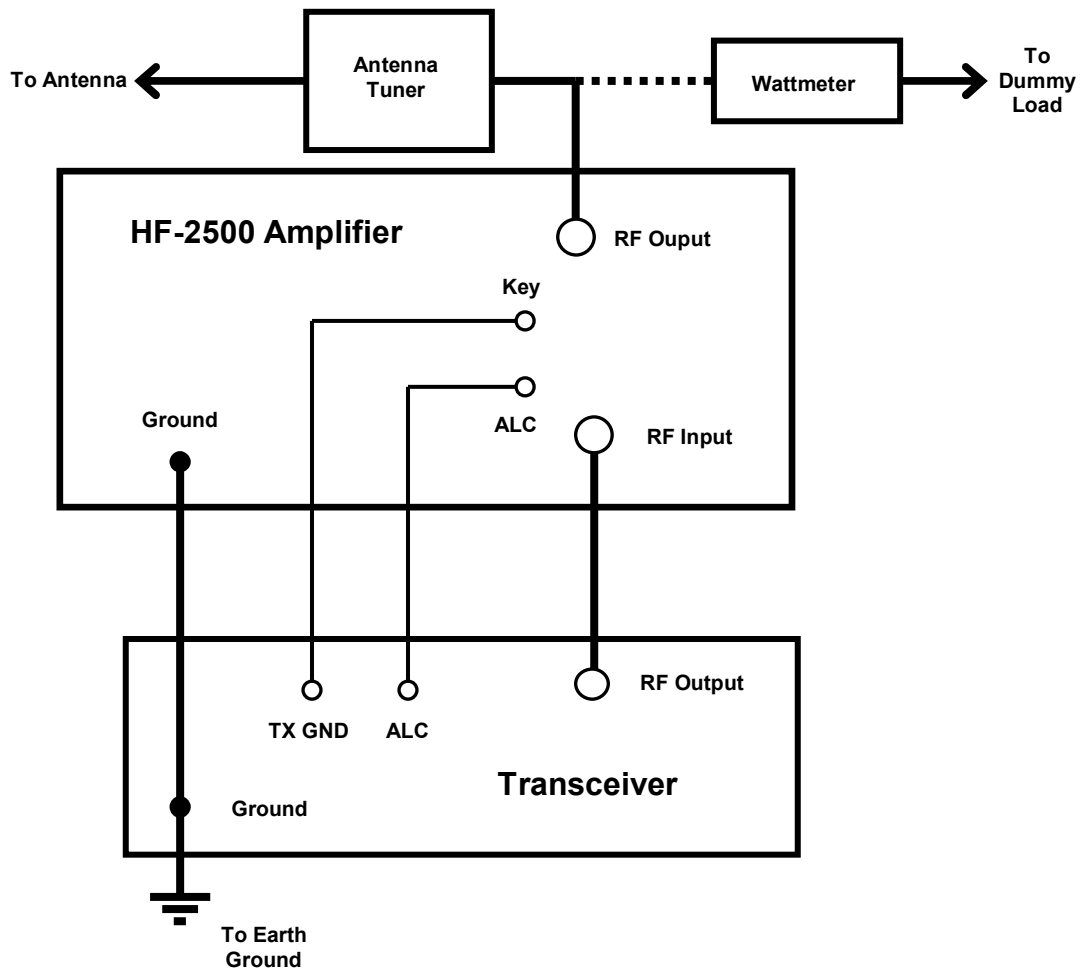

Rear Panel View

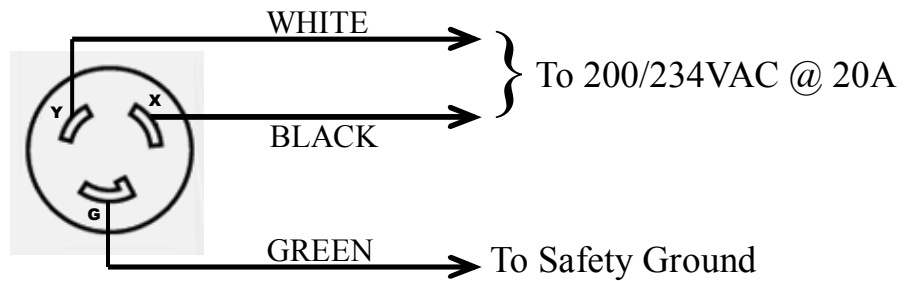
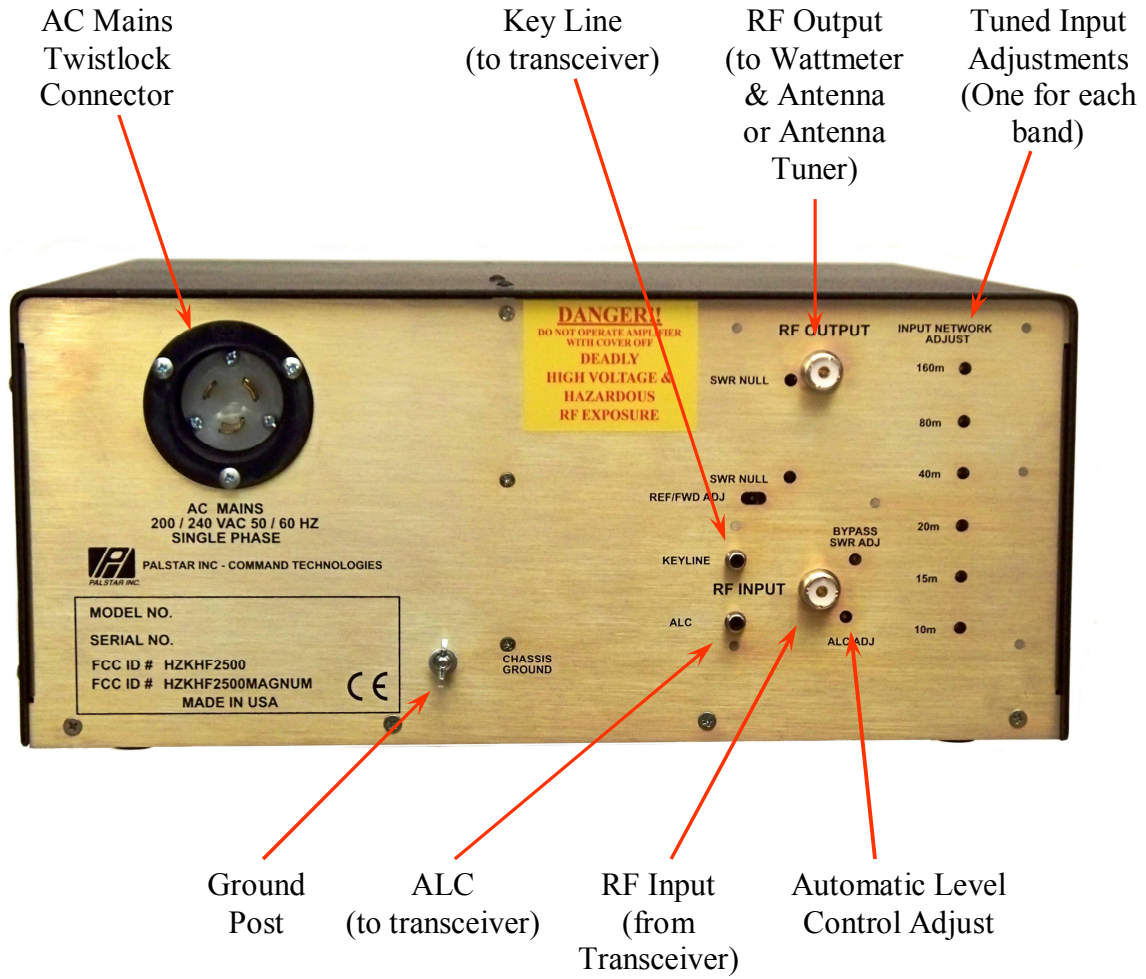

AC Power Twistlock Connector Wiring
(View looking at rear panel)

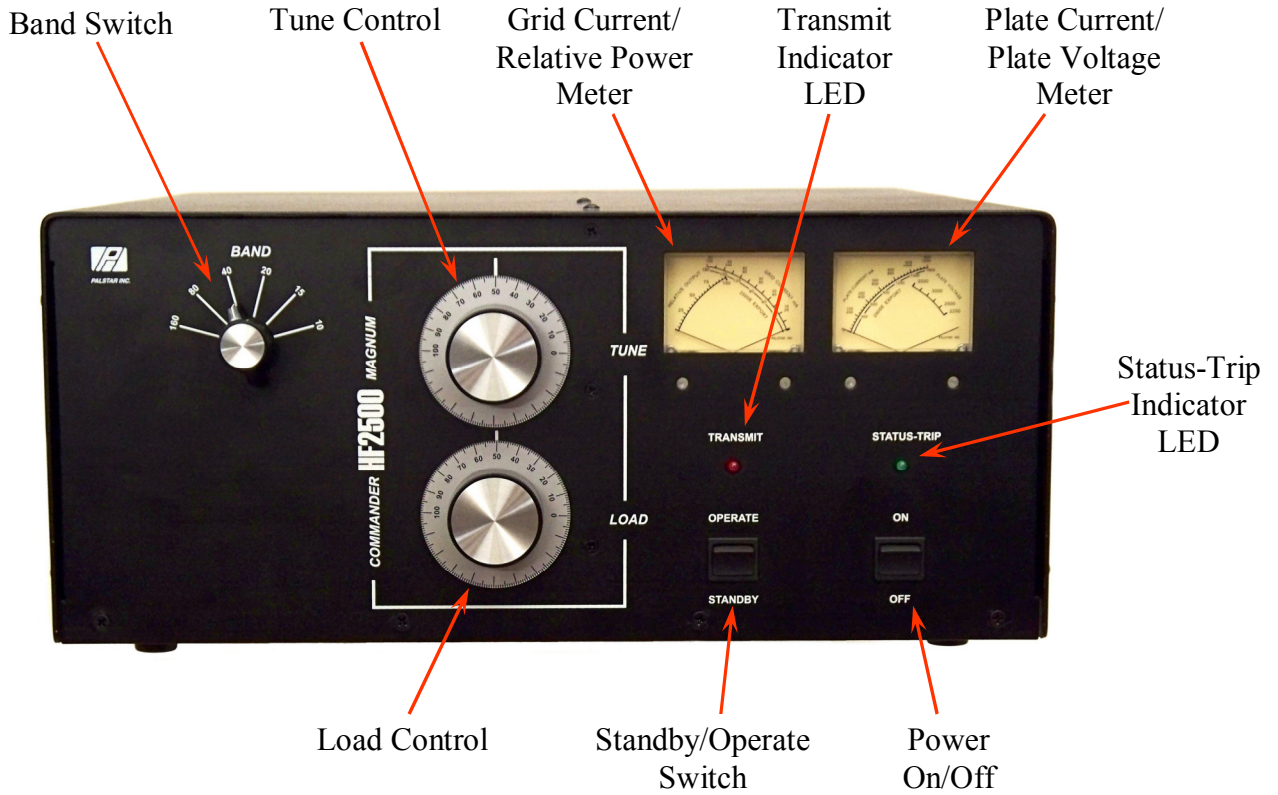

TUNING PROCEDURE

Set the front panel controls to the following positions:

- | | |
|-------------------|---------------------------------------|
| ON - OFF Switch. | OFF |
| STANDBY - OPERATE | STANDBY |
| BAND SWITCH | DESIRED BAND |
| TUNE CONTROL | PRESET TUNE SETTINGS (See test sheet) |
| LOAD CONTROL | PRESET LOAD SETTINGS (See test sheet) |

After the controls have been preset and the amplifier is connected to a suitable RF load, switch the On/Off switch to the On position. The following will occur:

- A. The meters will illuminate.
- B. The step-start relay will actuate and the HV will begin to ramp up.
- C. After 2 seconds the step-start relay will disengage and the HV will now be at its normal no-load voltage level.
- D. The 3 minute filament timer will start. The green “Status-Trip” LED will flash (1Hz rate) during the 3 minute warm-up interval.
- E. After 3 minutes the “Status-Trip” LED stops flashing and the amplifier is ready for use.

Place the Standby/Operate switch in the Operate position. The amplifier will not switch to the “Operate” state if the Keyline is active when the switch is thrown (this protects the amp in

case it is inadvertently keyed when the switch is thrown). Key the exciter with no RF drive applied. The red transmit LED should illuminate, and the meter should indicate approximately 120 mA of plate current. Apply 5 to 10 watts of RF drive, the plate current should rise slightly. If the plate current rises above 1200 mA, reduce drive. Adjust the **TUNE** to achieve maximum output power as indicated on an **EXTERNAL WATTMETER**. **COMPLETE THESE ADJUSTMENTS AS QUICKLY AS POSSIBLE TO AVOID STRESSING THE TUBES.**

Adjust the **LOAD** control to reduce grid current while maintaining output power as indicated on the relative output meter or an external Wattmeter. Next, increase the drive in small increments and **adjust the LOAD control to REDUCE the grid current** . Under normal conditions the grid current should not exceed 15-20mA at maximum power output.

Readjust the **TUNE** control to again peak the power output. If the grid current rises above 100mA. quickly reduce drive by adjusting the **LOAD** control **clockwise** to reduce grid current. Repeat these adjustments as required to achieve the desired output up to 1500 Watts.

[NOTE: Avoid operation at high grid current levels (~60mA or greater). If the grid current is allowed to reach or exceed 120mA, the controller will immediately un-key the amplifier and the “Status-Trip” LED will flash rapidly, indicating that a grid current limit (a “Grid-Trip”) has occurred.

***Expect to use the TUNE CONTROL to peak the power output and
and rotate the LOAD control CLOCKWISE to lower the grid current.***

In order to reset the Grid-Trip circuitry, the exciter must be un-keyed and the “Standby-Operate” switch must be switched to “Standby” and then back to “Operate.” Once the Grid-Trip has been reset, the “Status-Trip” LED will stop flashing and remain illuminated.

Do NOT exceed 1200mA plate current.]

Note that when increasing output power the tune scale will always read higher and the load will read lower. Also, the supplied inspection sheet has all of these settings and they should be used as a guide for this procedure. If your settings vary widely from these you have something wrong and should start over.

If your planned operation is on SSB, you should reduce the load control slightly counter-clockwise, reducing the TOTAL output slightly about 30 to 50 Watts. This adjustment is necessary to insure that the amplifier is sufficiently loaded to handle the plate current peaks caused by the complex voice patterns during SSB operation. **Nominal plate and grid current readings during SSB operation will be about 30 to 40% of the key down CW readings.**

CAUTION: THE TUNE AND LOAD AIR VARIABLE CAPACITORS MAY ARC IF MAXIMUM DRIVE IS APPLIED BEFORE THE AMPLIFIER IS PROPERLY TUNED. ALWAYS FOLLOW THE DESCRIBED TUNE-UP PROCEDURE TO AVOID CAPACITOR ARCING. ARCING MAY ALSO OCCUR IF YOU ATTEMPT TO TUNE INTO AN ANTENNA WITH A VSWR GREATER THAN 2:1.

Theory Of Operation

The Commander HF-2500/HF-2500 MAGNUM uses a pair of C.P.I. Eimac 3CPX800A7 pulse rated ceramic/metal triodes in a class AB₂ grounded grid configuration. Nominal drive power of 20 to 60 Watts will produce 1500 Watts of clean RF output power.

This amplifier will operate on the following amateur bands: 160, 80, 40, 20, 15, 17, 12 and 10 meters.

Metering Functions

The Commander HF-2500/HF-2500 MAGNUM has two illuminated cross-needle panel meters. The left-hand meter continuously displays 3CPX800A7 grid current and relative output power. Under typical operating conditions the grid current will be 20-50mA.

Plate voltage and Plate current are continuously displayed on the right-hand meter. The typical plate current under nominal rated output (1500 Watts) should range from approximately 700mA to 800mA on the HF-2500, and 900mA to 1100mA on the HF-2500 MAGNUM, with an absolute maximum of 1200mA.

Tuned Input Circuits and Adjustments

The tuned input circuits utilize an π impedance matching circuit with a high Q design. These circuits employ RF phase compensating capacitors to reduce intermodulation products. The use of mica trimmer capacitors allows adjustments to match the transceiver to the amplifier. The rear panel provides easy access to these trimmer capacitors. A front panel band switch selects the appropriate input filter.

Your Commander amplifier has mica trimmer capacitors which are easily accessed thru holes located on the rear panel. The tuned input circuits are factory tuned and should not be re-adjusted unless necessary. You can easily make adjustments for any change in your preference for operating frequency range. Also, slight adjustments may be necessary because of slight variations in impedances between your transceiver and the tuned input circuitry of the amplifier.

1. Install a SWR meter between the transceiver and the amplifier.
2. Make sure the Standby/Operate switch is in the Operate position and the band switch is set to the same band as the one for which you are making adjustments. Your amplifier should also be properly tuned and loaded (preferably onto a dummy load of sufficient capacity).
3. Apply drive, observe the SWR, and adjust the trimmer capacitor for minimum SWR. Be careful not to overdrive the amplifier.
4. Repeat this procedure for each band.

Automatic Level Control and Adjustments

An adjustable Automatic Level Control (ALC) circuit limits the peak output power. When properly set, this circuit insures that the amplifier can not be overdriven. Rear panel access allows for easy manual adjustment. A sample of the RF input derives the ALC voltage.

Your transceiver's internal ALC will maintain linearity. The amplifier's ALC will prevent overdriving the amplifier. The HF-2500/HF-2500 MAGNUM's ALC circuit was designed for negative going ALC voltage. Proper adjustment is as follows:

1. Use an insulated tool when making these adjustments.
2. Tune the amplifier for operation on the 20 meter band for full 1500 watts output.

3. With your transceiver set for 20 meter SSB operation, set the transceiver's microphone gain for normal operation as specified in its owners manual.
4. While speaking louder than normal into the microphone, adjust the ALC pot through the access hole on the rear panel . Adjust for 1500 Watts maximum output as indicated on an external peak reading Wattmeter.
5. On some newer model transceivers this adjustment can be made in the CW position. On these models (with your output at 1500 Watts) simply adjust for a slight drop in output.

Output Filter Circuit

The π variable network filter transforms the plate load impedance from approximately 2500 Ohms down to 200 Ohms, Two air variable capacitors and an associated inductor accomplish this transformation. A heavy duty band switch selects the proper inductance from high Q inductors with appropriate taps for the desired band of operation.

A design Q of 14 allows for good harmonic attenuation on all bands. A special reactance-tuned ferrite core 4 to 1 transmission line transformer steps down the 200 Ohm output of the π circuit to the 50 Ohm nominal antenna impedance. This also provides further harmonic attenuation of the output in the same manner as an L coil in a π -L network.

High Voltage Supply

The high voltage supply operates from 200/234 VAC, 20 Ampere line. The primary of the high voltage transformer is switched on and off with relays and incorporates a step-start circuit to limit in-rush current while the high voltage filter capacitors charge. The front panel On/Off switch applies AC mains power to the controller circuitry which then controls AC power to the filament and HV transformers. In the HF-2500 approximately 900 VAC is applied to a full wave voltage doubler circuit. In the HF-2500 MAGNUM, 2400 VAC is applied to a full wave bridge. Metering of the tube anode and grid current is accomplished by shunt resistors located in the negative return of the 3CPX800-A7 cathode. Plate voltage metering is accomplished by a resistor divider network in the B+ line of the high voltage circuit.

Limited Warranty

Palstar Inc. warrants the Commander HF-2500 and HF-2500 MAGNUM to be free from defects in material and workmanship under normal use and service to the **original buyer for a period of one (1) year from the date of delivery to that buyer** (the “Warranty Period”). Palstar Inc.’s obligation under this warranty is limited to repair or replacement of the product at its option at the Palstar factory in Piqua, OH.

This warranty is effective only when the product is returned to the factory with all transportation charges prepaid and examination of the product discloses the product, in Palstar’s judgment, to have been defective during the Warranty Period.

The Warranty Period shall not extend beyond its original term with respect to interim in-warranty repairs by Palstar. This Warranty Period shall not apply to any product which has been repaired or altered by anyone other than Palstar without prior written authorization. Warranty does not extend to any products which have been subject to damage from improper installation, application or maintenance in accordance with the operating specifications. Palstar neither assumes nor authorizes any person to assume for it any obligation or liability other than herein stated.

Shipping Your Amplifier Back to the Factory

Due to the necessity of shipping the amplifier with the HV transformer removed, please contact the factory for instructions before sending an amplifier back to us. There are circumstances in which it may not be necessary to return the HV transformer, thereby saving you shipping charges. When you call, Palstar will inform you if transformer return is necessary. If transformer return is necessary, remove it from the amplifier cabinet and ship it separately, and must be in its original packing.

Repair Policy

When sending in a product for service, see the section above. If not using the original packing materials, please “double” box it carefully with suitable padding and ship it insured for your protection. Please include a note clearly describing the problem, how you wish the item returned and how you wish to pay for the service. Package your unit properly. Palstar, Inc. is not responsible for merchandise damaged in shipment. Our service rate is \$30 per hour (1/2 hr. minimum).

Return Policy

All returns must receive prior authorization from Palstar. Returned items must be received in original—AS SHIPPED—condition including the original box, manuals, accessories, and copy of sales receipt. Returns must be within 14 days of purchase. Returned items are subject to a 25% restocking fee. Shipping is not refundable.

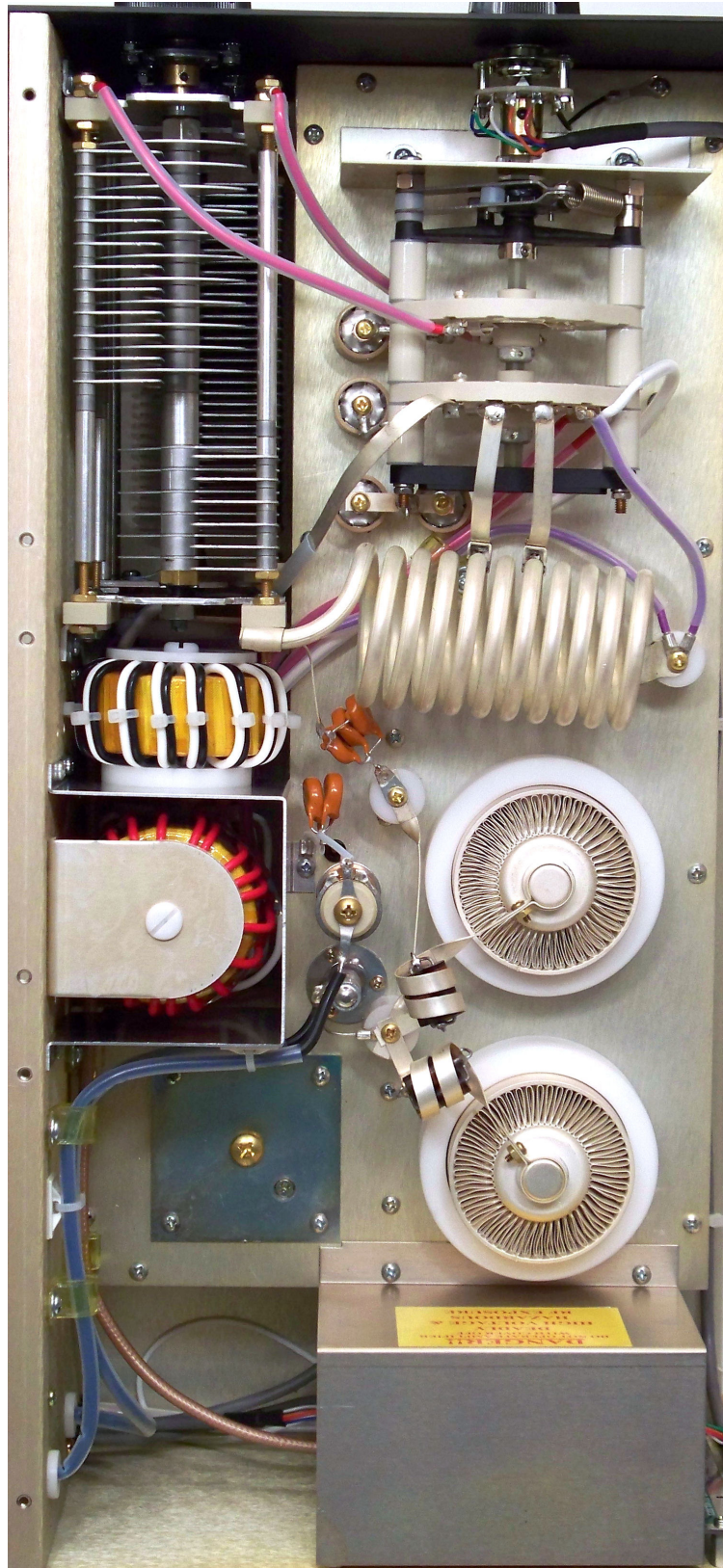
HF-2500/HF-2500 MAGNUM RF Deck

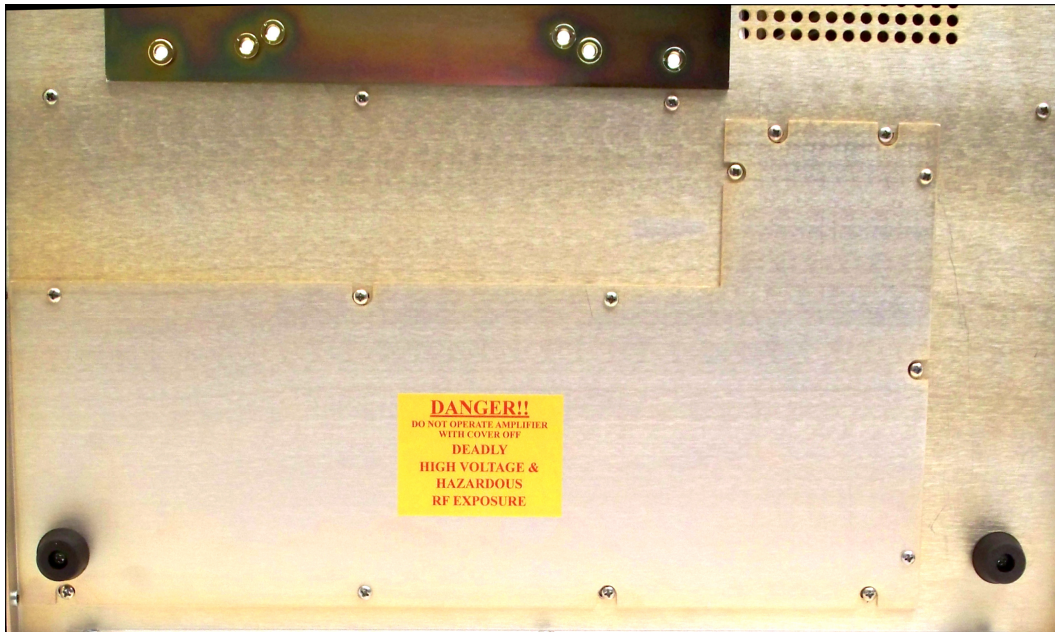

Bottom View showing access plate

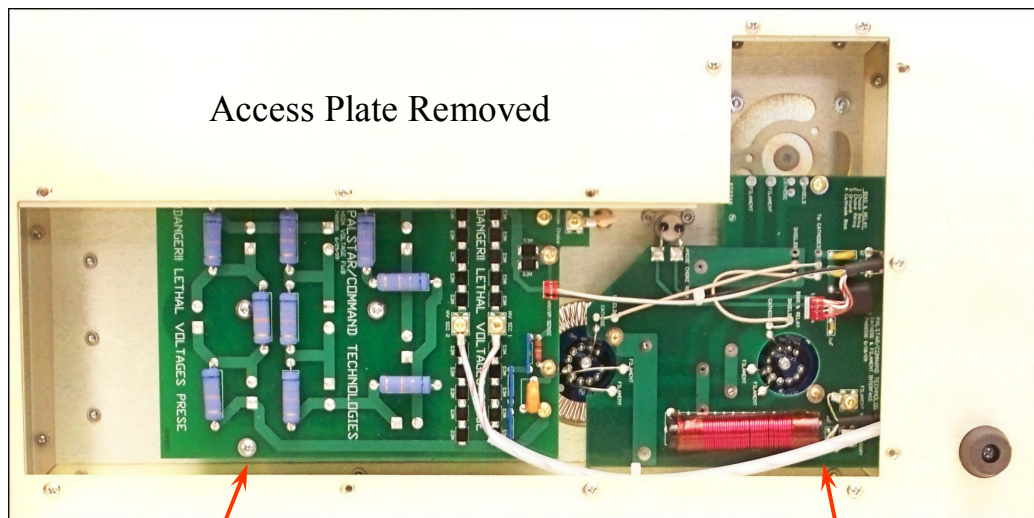

HV Power Supply PCB

Cathode and Filament Interface PCB

HF-2500 HV Power Supply

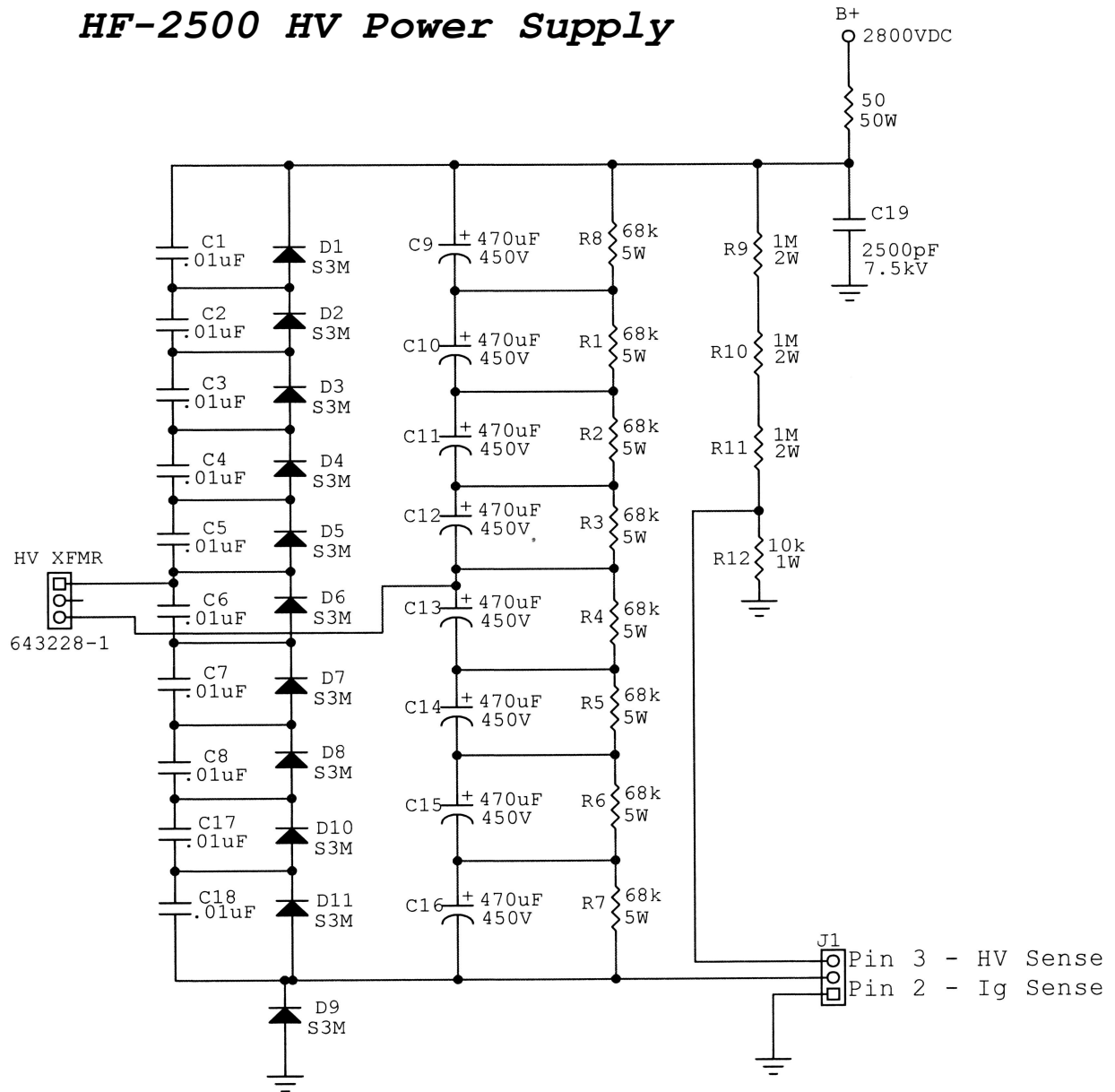

HF-2500 Magnum HV Power Supply

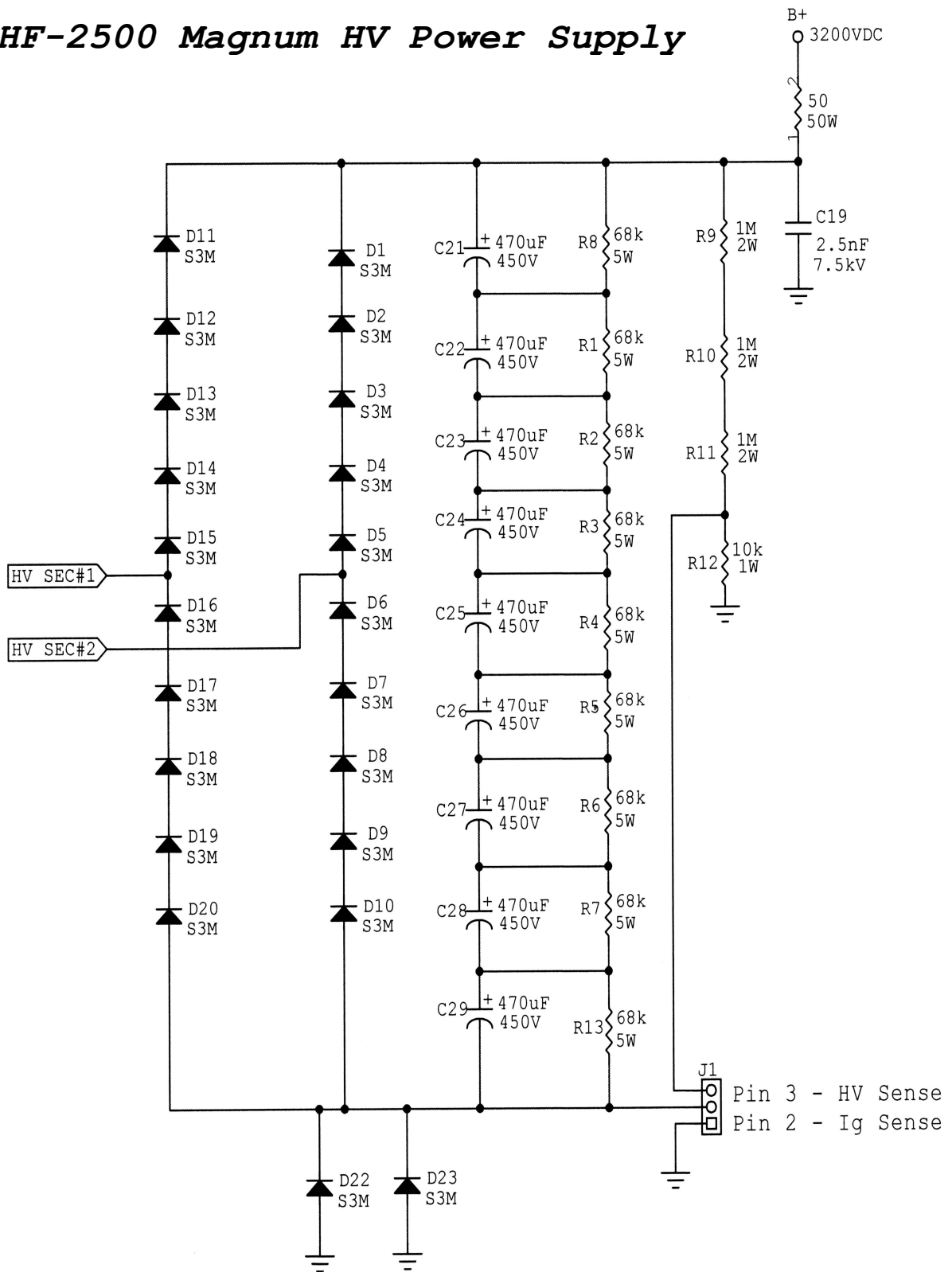

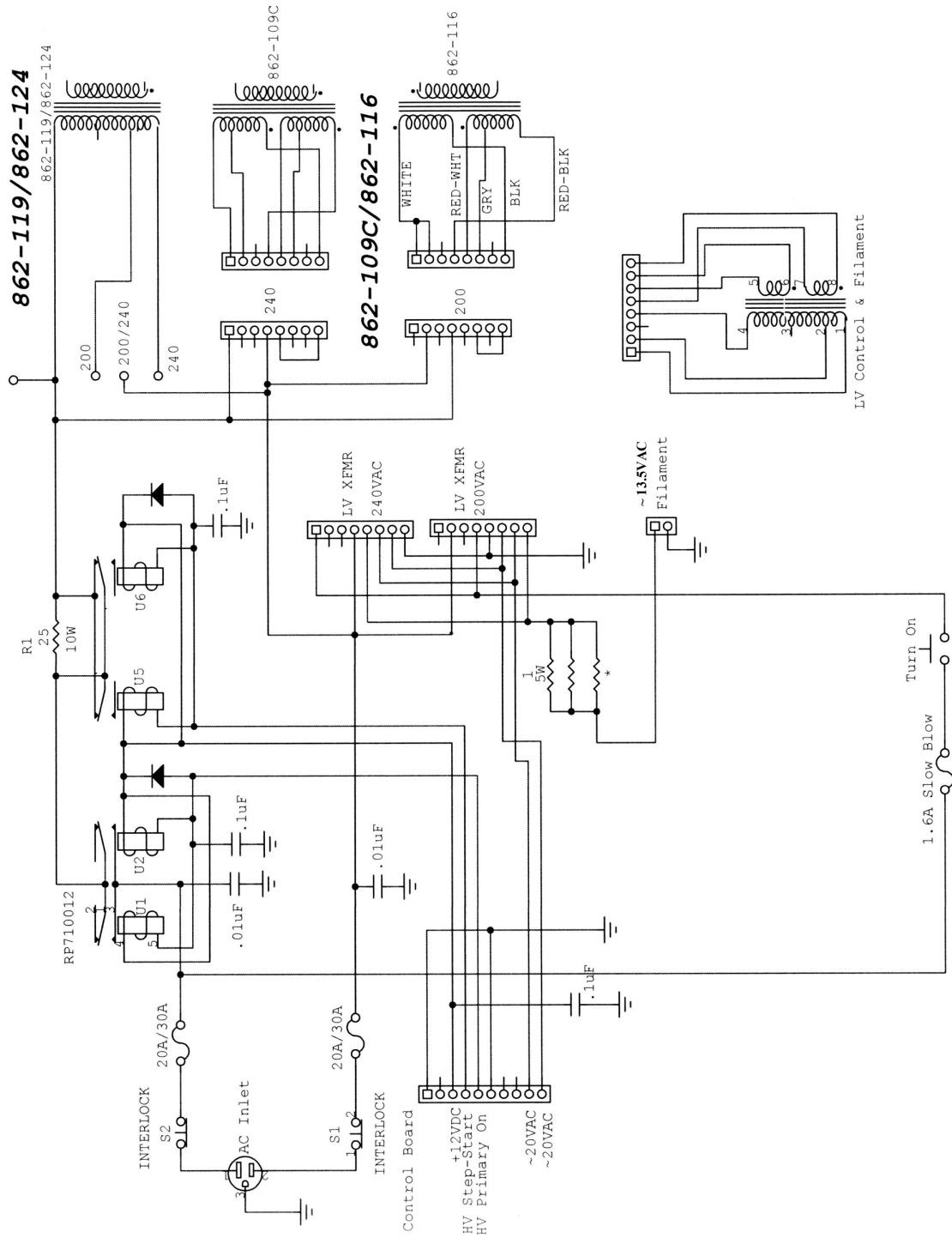

AC Mains and Step-Start Board

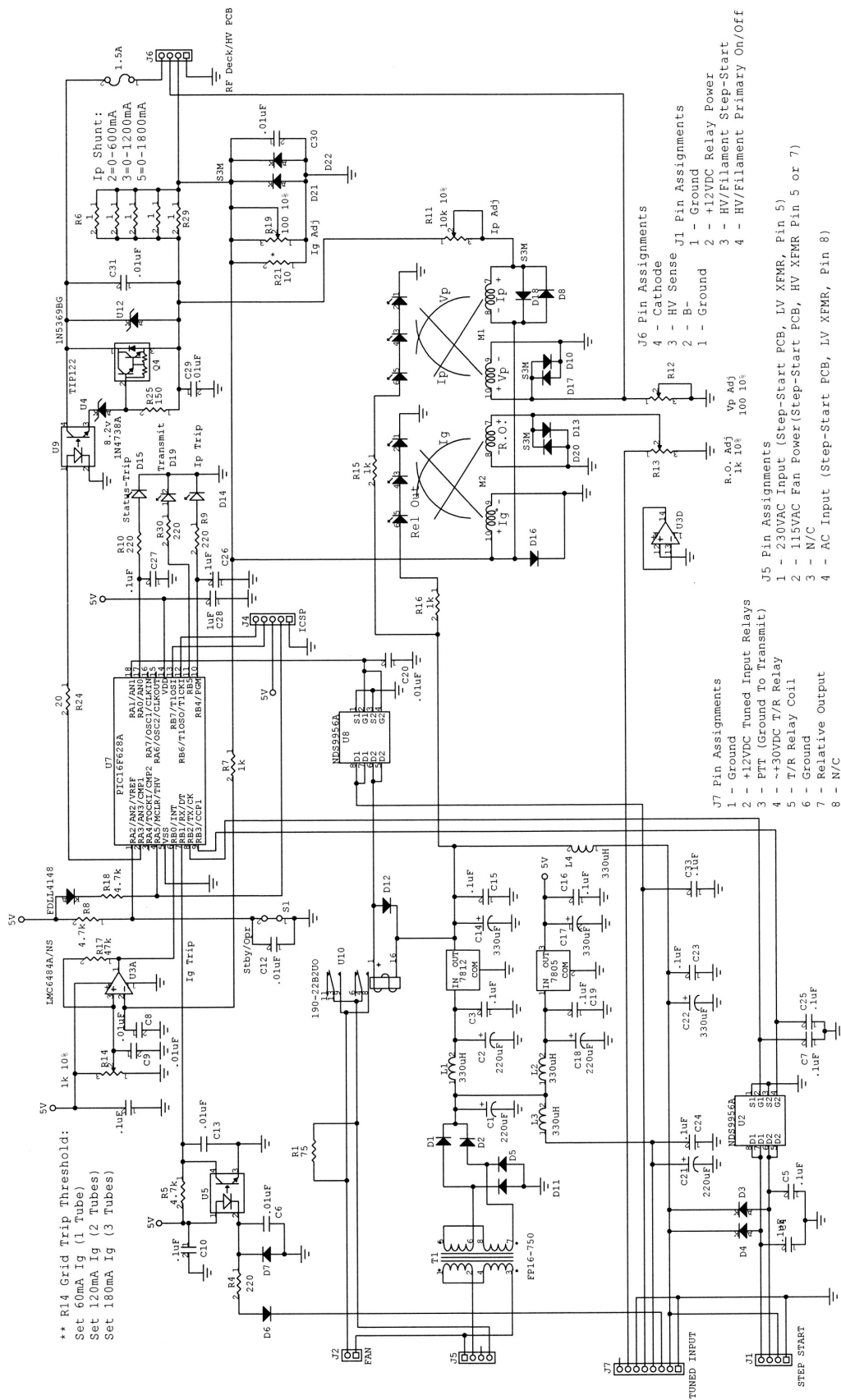

Control and Metering Board

HF2500 / HF2500 Magnum Tuned Input & T/R Changeover

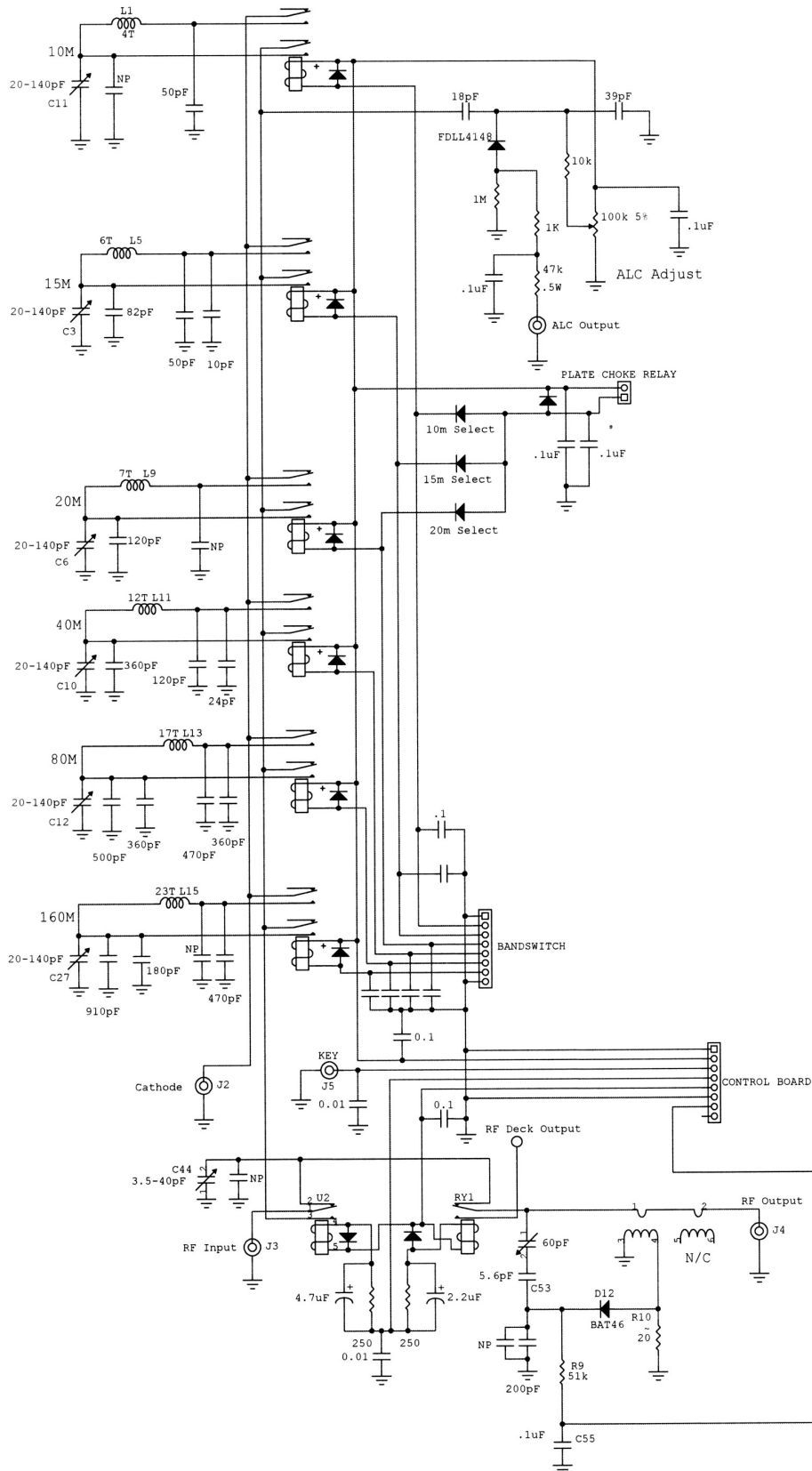

HF-2500/HF-2500 MAGNUM RF Deck

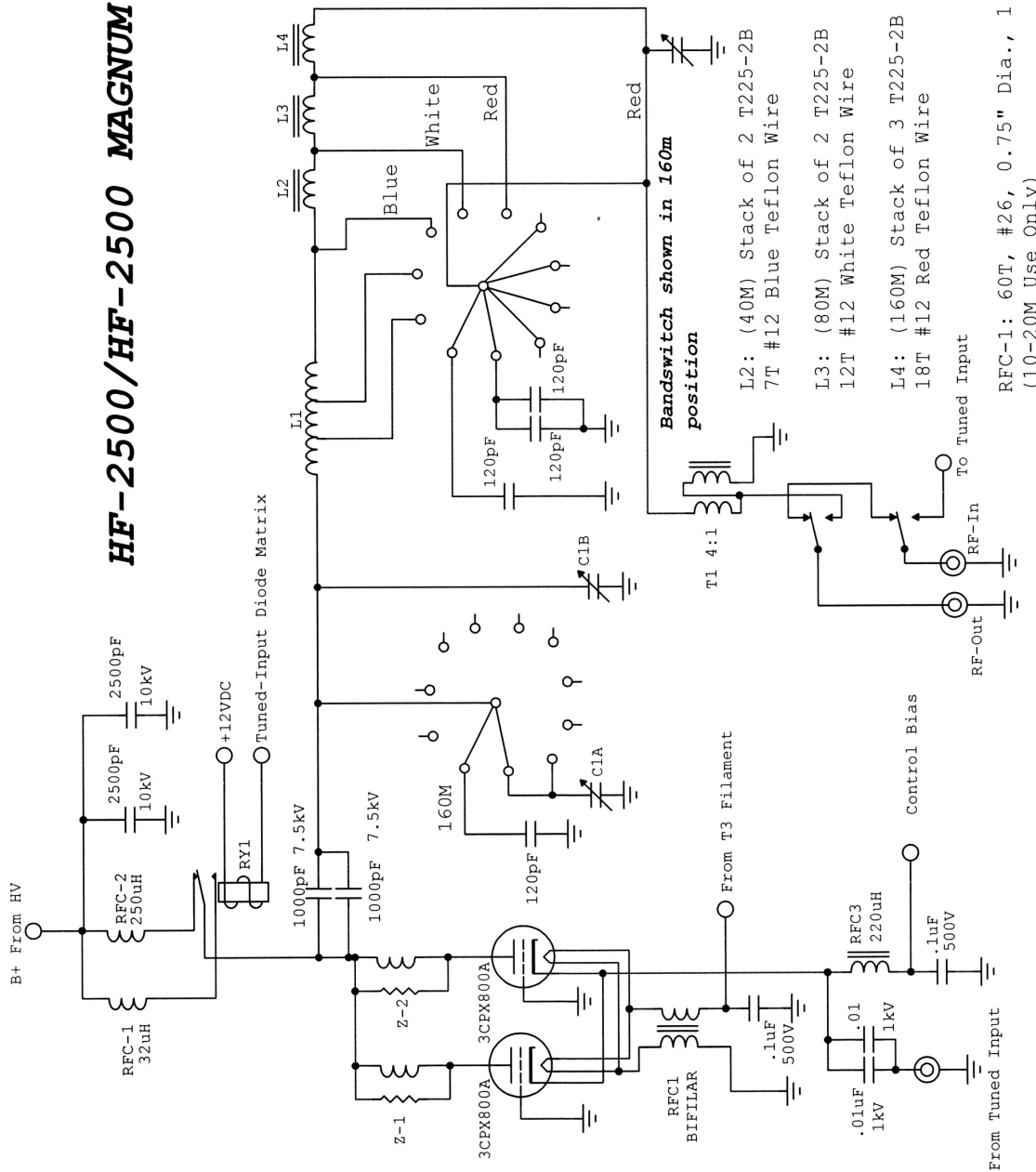

Bandswitch shown in 160m position

- L2: (40M) Stack of 2 T225-2B
7T #12 Blue Teflon Wire
- L3: (80M) Stack of 2 T225-2B
12T #12 White Teflon Wire
- L4: (160M) Stack of 3 T225-2B
18T #12 Red Teflon Wire

RFC-1: 60T, #26, 0.75" Dia., 1.5"L
(10-20M Use Only)

RFC-2: 105T, #26, 1.24" Dia., 3.25"L
(160-40M Use Only)

RFC-3: 12-12-12 Binocular Core (61)
#24

Dual Meters

Grid Current:		<u>Scale</u>
0-60ma	Single Tube	Top
0-120ma	Two Tubes	Mid
0-180ma	Three Tubes	Bottom

Grid Current:		<u>Scale</u>
0-600ma	Single Tube	Top
0-1200ma	Two Tubes	Mid
0-1800ma	Three Tubes	Bottom

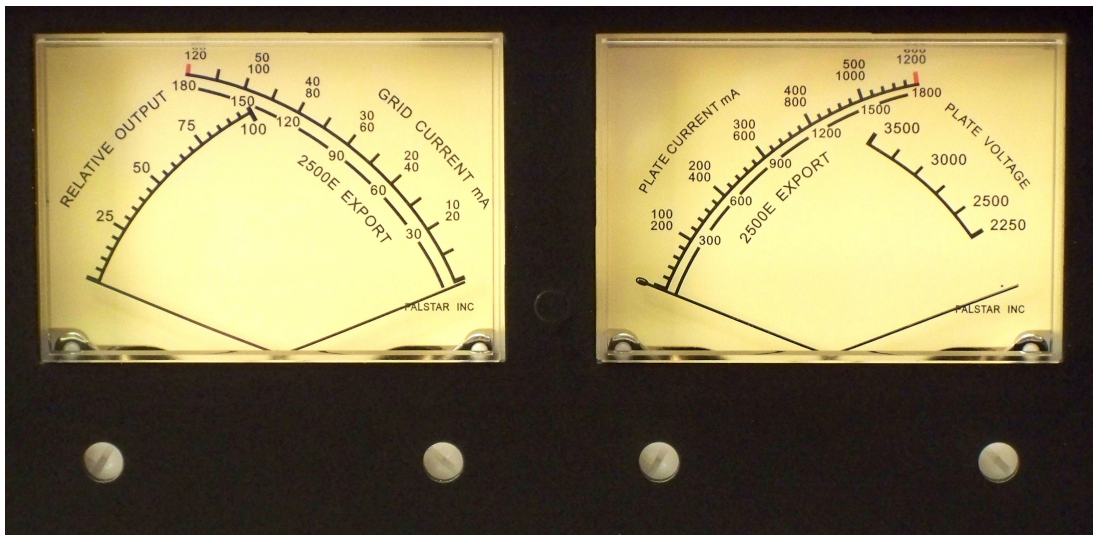

Step-Start Board

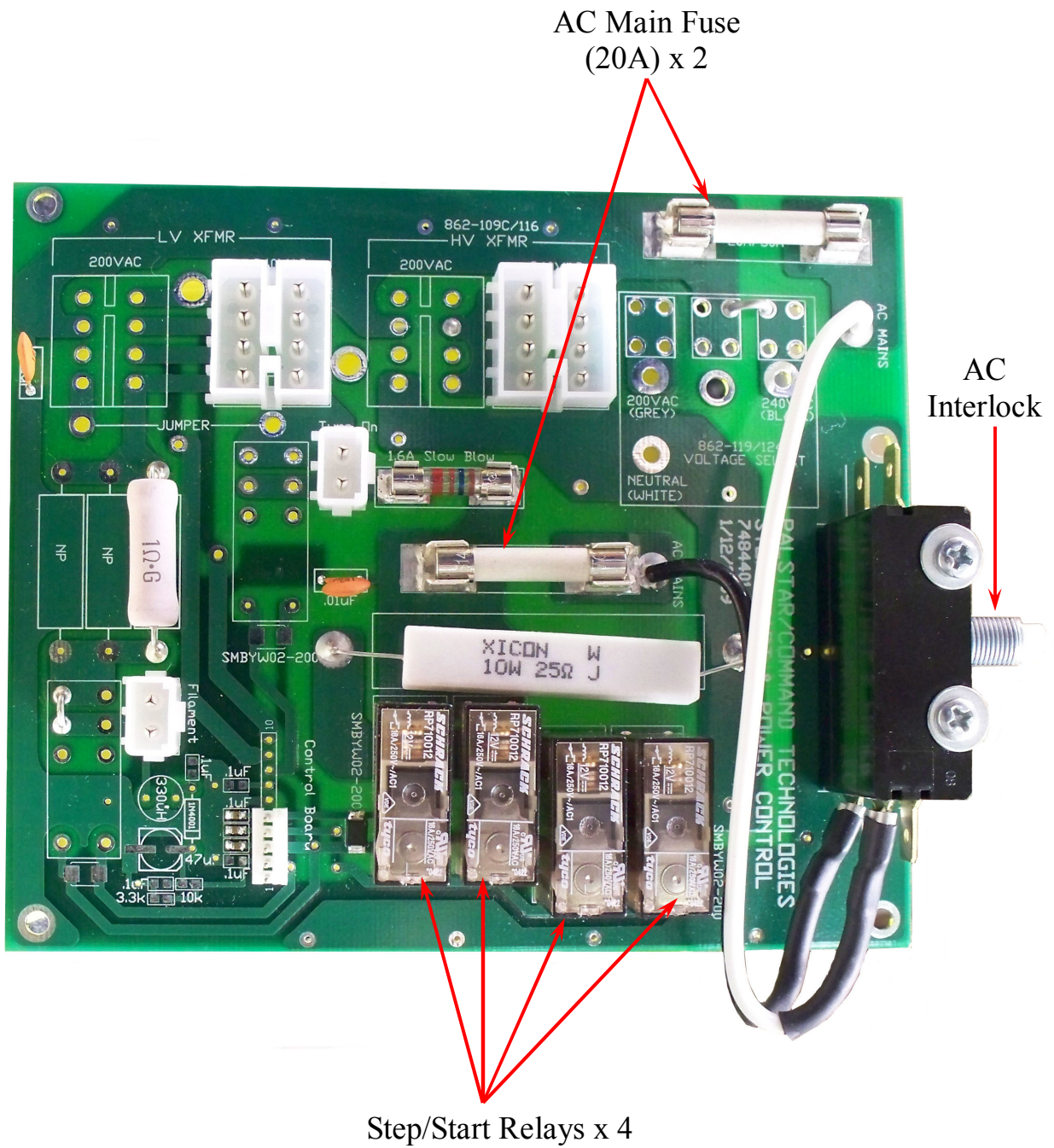

Full Wave Bridge Power Supply

Top

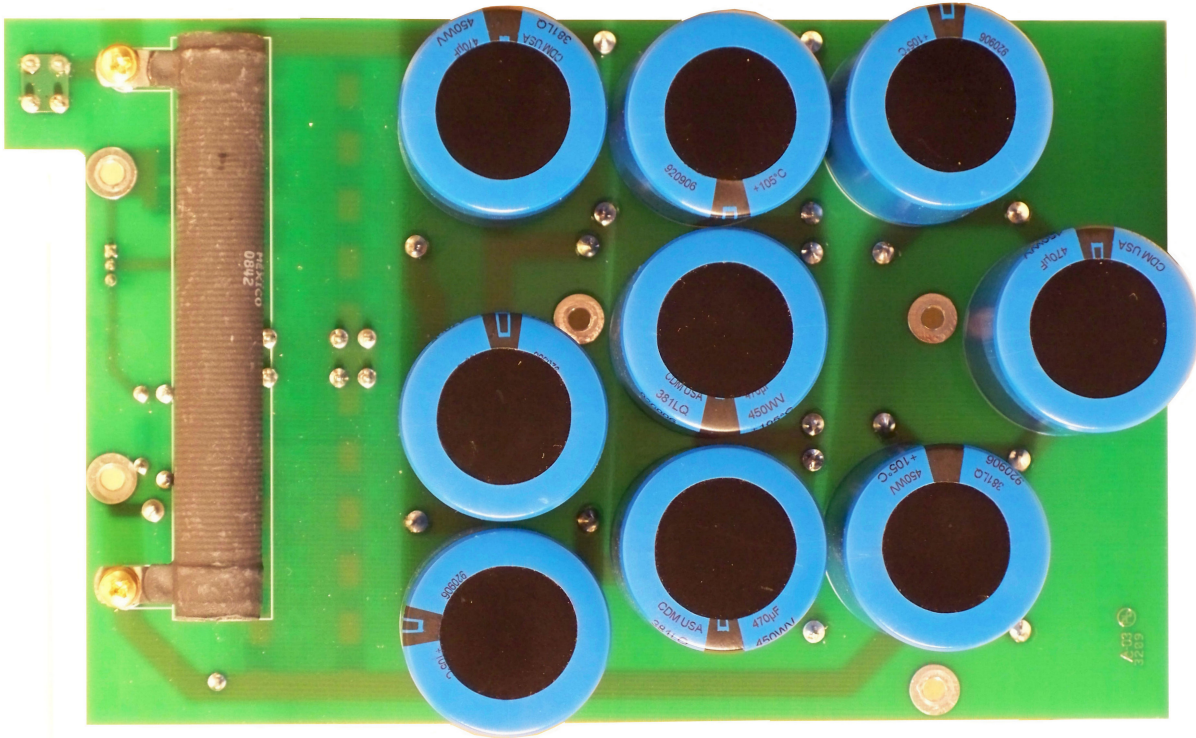

Bottom

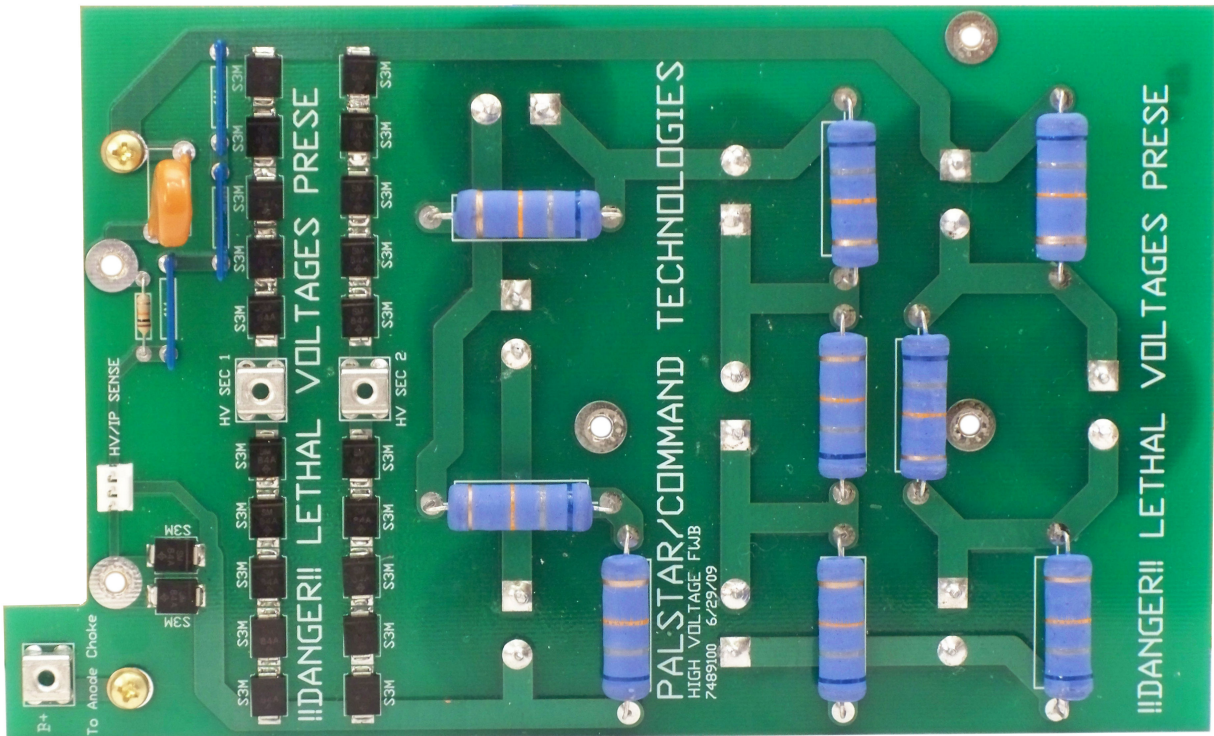



Palstar Incorporated

9676 N. Looney Rd.,
Piqua, OH 45356 USA

Customer Service and Sales Telephone:

1-800-773-7931

Fax:

1-937-773-8003

Email:

info@palstar.com