

Users Manual

Solid-State HF/50MHz Band
1kW Linear Power Amplifier

Model HL-1.5KFX



Tokyo Hy-Power Labs., Inc.

Contents

1.	Introduction	1
2.	Cautions	1
3.	Features	3
4.	Specifications	4
5.	AC Line Voltage	5
6-A	Front Panel Description	6
6-B	Rear Panel Description	8
6-C	Chassis Bottom Description	9
7.	Connection & Operation	10
8.	ALC Connection	13
9.	Band Data Cable Connection	14
	9-1 : ICOM DC Voltage Band Data	14
	9-2 : ICOM CI-V	15
	9-3 : Yaesu Band Data	16
	9-4 : Kenwood RS-232C Data	17
10.	Protection Circuits	18
11.	Explanations of Major Circuits	19
	11-1 : Main DC Power Supply	19
	11-2 : Power Amp, L.P.F.	20
	11-3 : RF Power Detector, TX-RX Switch	21
	11-4 : Main Control	22
	11-5 : Band Decoder, Frequency Counter	23
12.	Trouble Shooting	24
	Appendix	25
13.	<u>Schematic Diagrams</u>	26 - 33
	13-1 : PC1662V PA (Power Amp)	26
	13-2 : PC1681 L.P.F. (Low Pass Filter)	27
	13-3 : PCS1699 Main Control	28
	13-4 : PC1667 RF Power Detector	29
	13-5 : PC1669 Front Panel Board	30
	13-6 : PC1675 Pre-Scaler	31
	13-7 : PC1611FN/PC1611 DC-DC Converter	32
	13-8 : PCS1750 Surge Absorber Unit	33
14.	<u>Block Diagrams</u>	34 - 35
	14-1 : Simplified Diagram	34
	14-2 : Overall Diagram	35
15.	<u>Parts Layout</u>	36 - 40
	15-1 : Top View (Detailed)	36
	15-2 : Top View, Side View (Left), (Right)	37
	15-3 : Main Control (Front View), PCS1699 (Top & Bottom)	38
	15-4 : PA , LPF (Top & Bottom)	39
	15-5 : RF Power Detector, Pre-scaler, DC-DC Converter, Surge Absorber Unit	40
16.	<u>Rear Panel Connector Connections</u>	41

1. Introduction

Thank you for purchasing the HL-1.5KFX. This compact and lightweight desktop HF/50MHz linear power amplifier has a maximum input power of 1.75kW. Our solid-state broadband power amp technology makes it the smallest and lightest in the industry.

Typical output power is 1kW PEP/SSB on HF and 650W on 6m band with the drive power of 85-90W. The built-in band decoder will let you forget about the band setting when the amplifier is connected to your modern radio through such band data cables as ICOM CI-V, DC voltage (ICOM, Yaesu), and RS-232C (Kenwood). See the Appendix page 26 for the list of the recommended radios.

All the data cables are included in your amplifier for your convenience.

2. Cautions

2-1 Unpacking the amplifier, check the fan guard (net) at the rear panel to see if there is any damage caused by the physical shock during the transportation.

The amplifier is cooled by forced airflow. Several inches of clearance on the top and the rear wall are necessary to allow for smooth air intake into the fan. Do not block the air vents on the top cover.

2-2 Keep the amplifier out of direct sunlight, in a cool dry environment.

2-3 Internal high voltages (AC, DC and RF), are present at all times, ON AIR or OFF. Internal access should be limited to avoid injury.

2-4 Turn off the AC main power immediately upon any unusual sounds, sights or odors. Check the multimeter readings of Vd and Id, the fuses and all cable connections around the amplifier. Please notify the dealer or the factory of any problems.

2-5 For your safety, do not operate the amplifier without adequate grounding. A proper ground connection will result in peak performance and stability, in addition to reduced RF strays or noises.

2-6 To eliminate the RF interference to such home appliances as TV, FM radio, telephone sets, and etc., it is recommended that clamp-on ferrite cores be inserted at both ends of the remote control cable, ALC cable, coaxial jumper cable, and antenna cables, as needed. Also, a common mode AC line filter (near the AC outlet), and in-line low pass filters on the antenna coaxial cable, (as necessary), are recommended.

2-7 The amplifier has fast acting sophisticated protection circuits controlled by the latest microprocessor technology. Please note, however, any such actions that cause the same fault to occur repeatedly, will lead to failure of the valuable final power FET transistors. Also note that the **full power CW (or carrier) drive under the erroneous MANUAL BAND SET** leads to the failure of the final power FET's. (See Section 6, at page 11.) In this sense, it is highly recommended that the amplifier is connected to the

radio with supplied Band Data Cable.

2-8 Before checking inside the amplifier, be sure to wait a few minutes for the high DC voltage to discharge (monitor Vd meter reading). The potentiometers for RF power detector, protection circuits, FET bias voltage circuit, etc, are precisely adjusted at the factory, and should not be altered. Doing so, would require readjustment with precision measuring instruments.

2-9 The primary power transformer is factory pre-wired for AC 230V operation. Sliding the select switch located on the bottom of the chassis will switch the voltage from 230V to 115V. (See AC Power section.) Be sure to verify switch selection before you plug the AC power cord into the outlet.

2-10 Before powering on the amplifier, be sure to connect a dummy load (50 ohms, 1kW min.) or a well-adjusted antenna to the output terminal. Operating without any load will cause extreme stress to the RF power FET's, although protection circuits should work under critical conditions.

2-11 Required drive power is slightly less than 100W to obtain the full 1kW output. Do not attempt to operate with excessive drive from a high power transceiver. Transmitting high drive RF (over 100W) into the amplifier will void the warranty.

2-12 Keep the aluminum heat sink and air openings free from dust and blockages. Periodic cleaning will prevent degraded cooling efficiency.

2-13 For long continuous operation in RTTY modes, it is recommended you reduce the RF drive levels by 20% to 30% lower output than CW/SSB modes. Optional Fan Kit recommended.

2-14 To prevent damage to the precision electronic components, avoid extreme physical shock to the amplifier. If factory service is required, the amplifier **MUST** be shipped using the original box and packaging materials.

3. Features

3-1 Our solid-state broadband design engineers worked to make the HL-1.5KFX, the lightest and most compact 1kW HF amplifier in the industry. This world-class compact 1kW HF/ 6m amplifier is the easiest to handle and operate.

3-2 The amplifier is equipped with a newly developed band decoder. The amplifier's decoder changes bands automatically as the data signal is received from the associated HF transceiver's frequency bands.

3-3 The amplifier's main PA section includes 4 high power MOS FET SD2933 / THP2933, resulting in 1kW PEP (SSB max.) on HF and 650W on 6m. The amplifier's broadband characteristics require no further tuning once the operating band is selected.

3-4 The amplifier allows operation in full break-in CW mode due to the use of the amplifier's high-speed antenna relays (made by Panasonic/Matsushita).

3-5 With the unique duct structure design and the powerful blower fan, the aluminum heat sink block for RF PA module (and other components), are effectively cooled. The fan's quiet operation allows for even the weakest DX signals to be heard.

3-6 The amp utilizes an advanced 16 bit MPU (microprocessor) to run the various high speed protection circuits such as overdrive, high antenna SWR, DC overvoltage, band miss-set etc.

3-7 This amplifier is compatible with both AC 230V (200/220/240V included) and AC 115V (100/110/120V included). See the illustration in the AC Power Section for changing primary wiring of the power transformer.

3-8 For the safety of the operator, an Interlock system is employed. The AC power is shut down if the top cover is removed, and the automated safety interlock is activated.

3-9 An analog multimeter allows the operator to monitor Pf (Forward output power), Pr (Reflected power), Vd (Drain voltage of power FET), Id (Drain current) etc

3-10 For future expansion, the amplifier rear panel is equipped with a control cable connection socket, this is for the upcoming model HC-1.5KAT, auto antenna tuner by Tokyo Hy-Power Labs.

4. Specifications

Frequency: 1.8 ~ 28MHz all amateur bands including WARC bands and 50MHz

Mode: SSB, CW, RTTY

RF Drive: 85W typ. (100W max.)

Output Power: HF 1kW PEP max., 900W CW (typ.)
50MHz 650W PEP max.

Matching Transceivers for Auto Band Decoder:

Most ICOM, Yaesu, Kenwood

Drain Voltage: 53V (when no RF drive)

Drain Current: 40A max.

Input Impedance: 50 (unbalanced)

Output Impedance: 50 (unbalanced)

Final Transistor: SD2933 / THP2933 x 4

Circuit: Class AB parallel push-pull

Cooling Method: Forced Air Cooling

MPU: PIC 18F8722

Multi-Meter: Output Power Pf 1kW
Reflected Power Pr 100W
Drain Voltage Vd 60V
Drain Current Id 50A

Input/Output Connectors: UHF SO-239 with low loss Teflon insulator

AC Power: AC 230V (200/220/240V) 10A max.
AC 115V (100/110/120V) 20A max.

AC Consumption: 1.9kVA max. when TX

Dimension: 272 x 142 x 363 mm (WxHxD)
10.7 x 5.6 x 14.3 inches

Weight: Approx. 20kgs. or 45.5lbs.

Accessories: AC Power Cord x 1
RCA Plug x 2
Band Decoder Cable x 4
Spare Fuse 15A (for AC 230V line) x 2
Spare Fuse 25A (for AC 115V line) x 2
Spare Fuse 2A (Miniature Fuse) x 2
(For PCS1669 , main control board x 2)
Spare Fuse 2A (Miniature Fuse) x 2
(For PC1611 FN DC-DC board x 1, PC1662V, power amp board x 1)
Users Manual x 1

Optional Items: Auto Antenna Tuner (HC-1.5KAT)
External Cooling Fan (HXT-1.5KF for high duty cycle RTTY)

5. AC Line Voltage

5-1 Although the amplifier is designed to work with both AC 115V (100-120V) and AC 230V (200- 240V), for stability we recommend operation from AC 230V.

5-2 The correct AC plug (not included in the package), must be obtained locally due to the AC plug variations worldwide.

5-3 The AC voltage has been factory preset for 230V use (or as requested by the customer at the time of order). If you wish to change to AC 115V, change the voltage setting by sliding the switch knob located on the chassis bottom (as illustrated below). See the other illustration for AC voltages other than 230/115V. For your safety, before making these adjustments, be sure to pull the AC plug from the AC outlet to avoid injury.

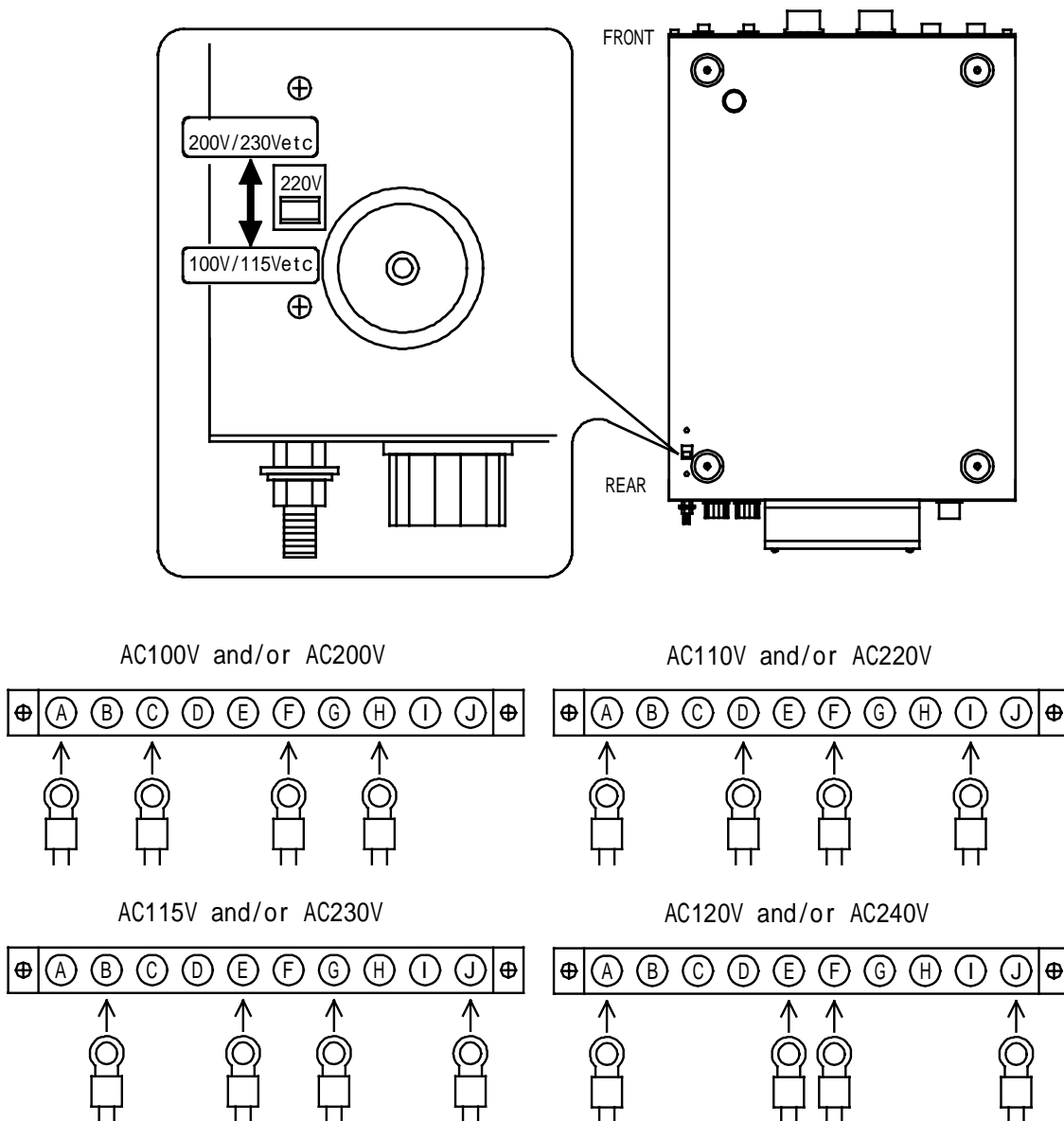

6-A. Front Panel Description

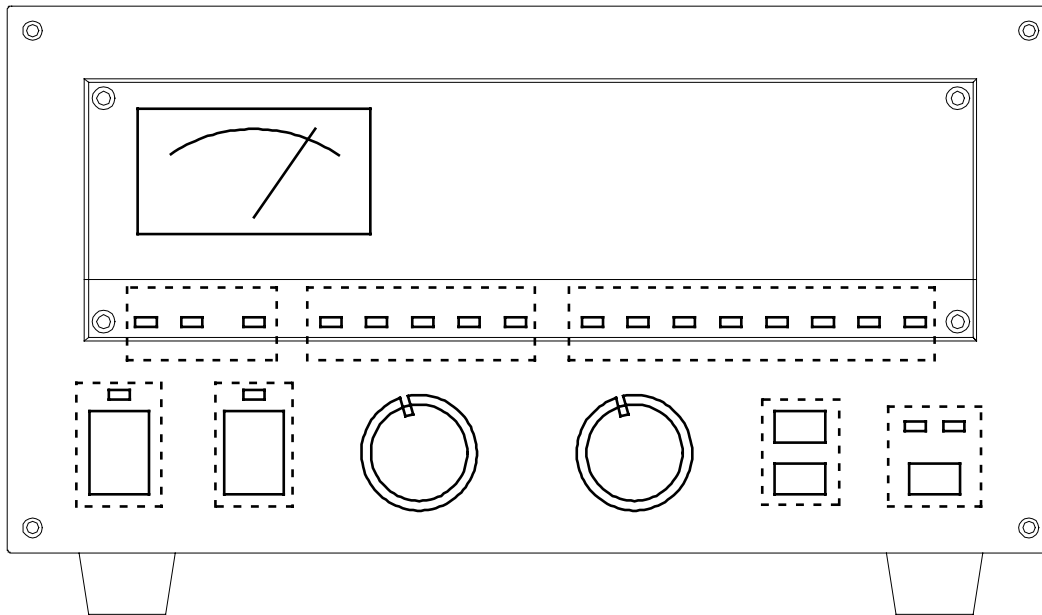

POWER Main power switch to turn AC power on and off.
LED (green) lights when turned on.

OPER. OPERATE /STAND-BY switch. At OPERATE, the amplifier is ready to go into ON AIR (TX) mode and at STBY, it is on STAND-BY mode.

METER To change the multimeter scales. Meter reads Pf, Pr, Vd, and Id.

BAND SELECT

To select band switching methods AUTO or MANUAL. When using AUTO, the manufacturer for the transceiver in use should be selected. When the band data cable is not used, MANUAL should be selected. (See page 14, 9. Band Data cable Connection)

UP, DOWN Push switch for band change in manual mode. While the transceiver is on Receive (RX) mode, push the button to select the desired frequency band to operate. The switches will not work when the transceiver and the amplifier are in Transmit (TX) mode.

ANT Select switch for antenna A or B. A and B are selected alternatively, as the switch is pushed. The selected antenna is stored in the memory for the respective bands. Note the antenna switch always defaults to A when the POWER switch is turned off.

FAN, ID, ON AIR

-1 ON AIR: Green LED lights when the amplifier is in transmit (TX) mode.

-2 FAN: This LED lights when the cooling fan runs at high speed. When the PA heat sink temperature reaches 40 degrees C, the fan will run at high speed for enhanced cooling. If the FAN LED is lit, it is recommended that the power switch not be

turned off immediately after finishing operation. Allow the cooling fan to run for an extended period of time.

- 3 ID: Excessive Id Indicator (>35A). Depending on the band and antenna situation, high drain current may flow into FET's. If 35A is exceeded, this LED flickers and/ or lights to indicate that high Id is being drawn. (This light does not necessarily mean a failure of the amplifier. However if it lights too often, or too long, it is possible the drive power should be reduced and the antenna should be checked for SWR, to avoid stress to the FET's).

O. DRIVE, O. HEAT, O. VOLT, FUSE, PR

- 1 O.DRIVE: When overdrive or band miss-set is detected, LED lights to indicate the protection circuit has worked.
- 2 O.VOLT: When the DC drain voltage of the FET's (Vd) is too high, the LED lights to indicate the protection circuit has worked.
- 3 O.HEAT: When the PA module temperature reaches 70 deg. C, the LED lights to indicate the protection circuit has worked. (It is necessary for the cooling fan to operate for several minutes to cool the PA module).
- 4 FUSE: LED lights when the 20A glass fuse has blown from excessive Id. (Two 20A fuses are on the PC1622V PA board.)
- 5 PR: LED lights when reflected power from antenna exceeds 80W to indicate protection circuit has worked.

(Turning the main POWER switch to off, and then on again can reset the Protection Circuits.)

BAND One of the green LED lights will indicate which band is selected for operation.

MULTIMETER Pf (Forward output power), Pr (Reflected power from antenna), Vd (FET drain voltage), and Id (FET drain current) are shown on the scale as selected by METER select switch.

6-B. Rear Panel Description

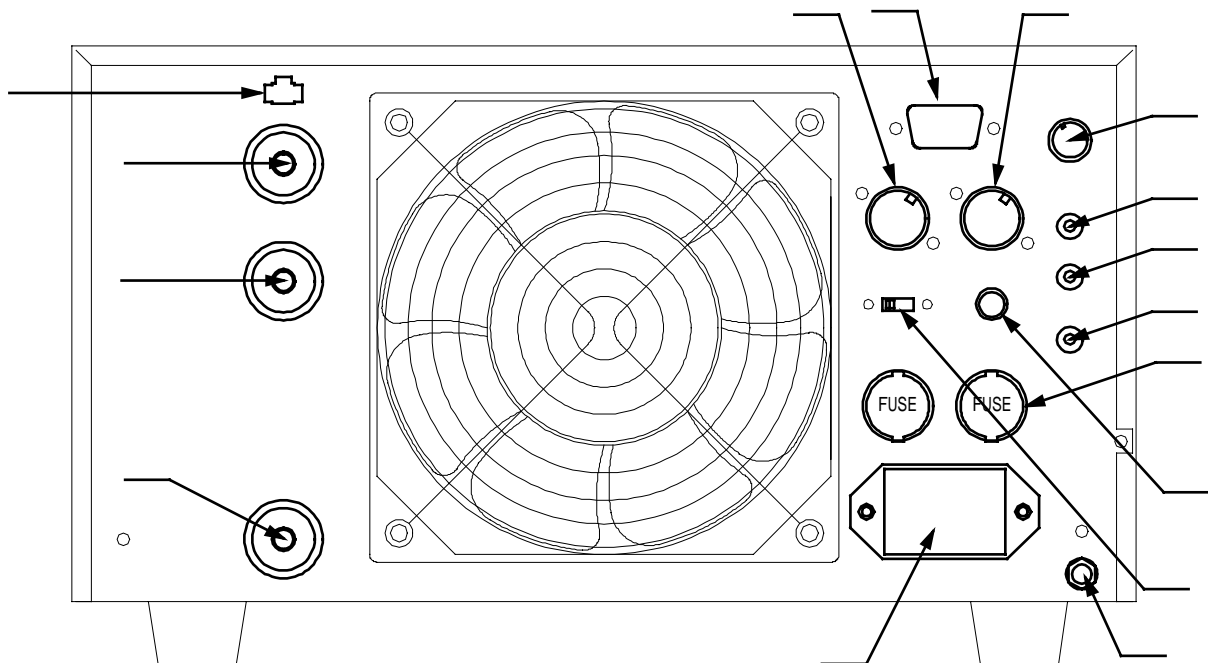

- ANT A** RF Output Connector. Connect the coax cable to the antenna.
- ANT B** RF Output Connector. Connect the coax cable to a second antenna or a dummy load (50 1kW for example).
- INPUT** RF Input Connector. Connect the coax jumper cable from the transceiver.
- AC POWER** AC Mains Socket. Socket for the AC power cord. (Socket is EMI filtered.)
- GND** Ground Terminal.
- SEND** RCA Jack. Connect the control cable from the ACC terminal (or SEND, TX GND etc.) of the transceiver. The center pin is to be shorted to ground through the relay circuit of the transceiver for the amplifier to be keyed. The DC current flowing into your radio to key the amplifier to transmit is as low as 5V, 1mA.
- ALC** RCA Jack for ALC Voltage Output. Negative DC voltage appears at the center pin, which is fed back to the ALC terminal of the transceiver. ALC is used to keep the amplifier output power at certain limits. Also it is useful when the transceiver output power is higher than 100W. (See page 13. 8. ALC Connection). Also consult your HF transceiver's user manual.
- ALC ADJ.** Potentiometer to adjust ALC voltage level. Minus 10V is available at maximum, when turned full counter-clockwise. Factory setting is 0 volts, with the pot turned full clockwise.
- FUSE** A pair of fuses for AC Mains. 15A glass fuse. (Change to 25A fuses if 115V line voltage is selected.)

ICOM RCA Jack for the DC voltage derived band data cable from the ICOM transceiver. (Reference page 14, Band Data Cable Connection with ICOM.)

CI-V Earphone jack for CI-V band data cable for ICOM transceivers so equipped. (See page 15.)

BAND DECODE

Slide switch to select band data communication method with ICOM transceivers. This selects either “DC voltage band data” or “CI-V band data”.

TUNER DIN Socket for External Auto Antenna Tuner.

YAESU DIN Socket for band data cable from the Yaesu transceiver. (See page 16.)

KENWOOD D-Sub (9 pin) socket for band data cable for Kenwood transceivers (RS-232C). (See page 17.)

EXTERNAL FAN POWER

Plastic Female Connector for DC power supply cable to feed the optional external cooling fan kit (HXT-1.5KF).

6-C. Chassis Bottom Description

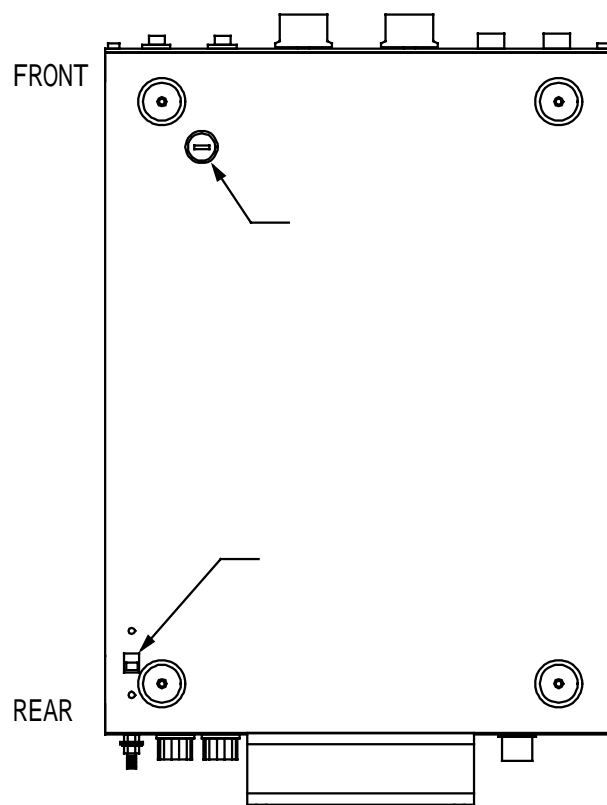

AC 115/220V Slide switch to select AC line voltage. Set to 220V for 200/220/230/240V. Set at 115V for 100/110/115/120V lines.

FUSE Fuse socket for the External Cooling Fan Unit, HXT-1.5KF. When the optional fan is installed on top of the cover, a 1A glass fuse is recommended.

7. Connection & Operation

This section explains a one-antenna system or two antenna system with basic connections to the transceiver, where no band data cable is connected. In this case, band setting is made with MANUAL mode, pushing UP/DOWN keys. Advanced operation using the band data cable is described in Section 9.

***** CAUTION :** Under the Manual Band Set operation, always be sure to check if BAND Switch position matches that of your radio before keying PTT or the CW paddle. Also when you have changed the BAND, do not make the full power CW (carrier) drive but reduced level power to see if the BAND is set correctly and the amplified RF power comes out properly. **Full power CW drive under the BAND Miss-Set leads to the failure of the valuable final power FET devices.** ***

One Antenna System Example

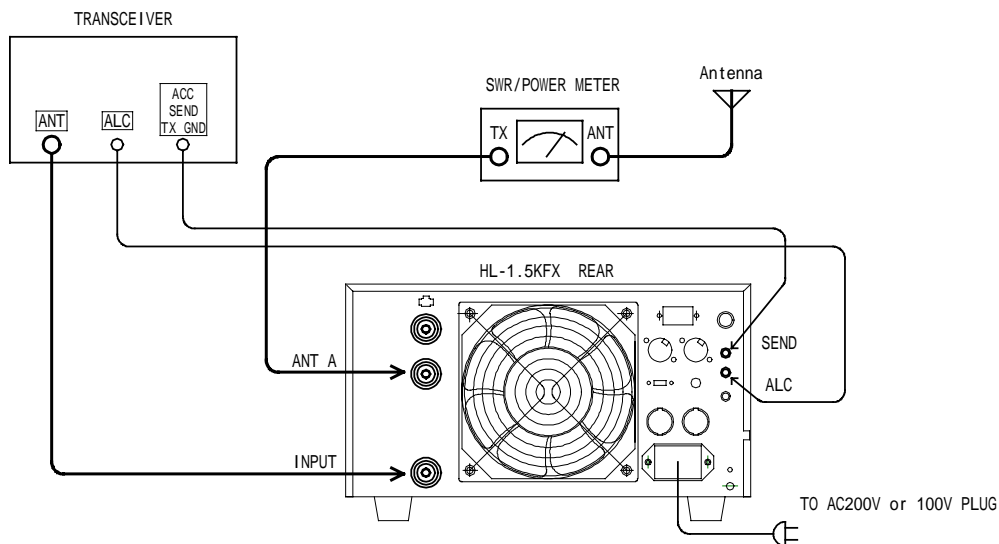

Two Antenna System Example

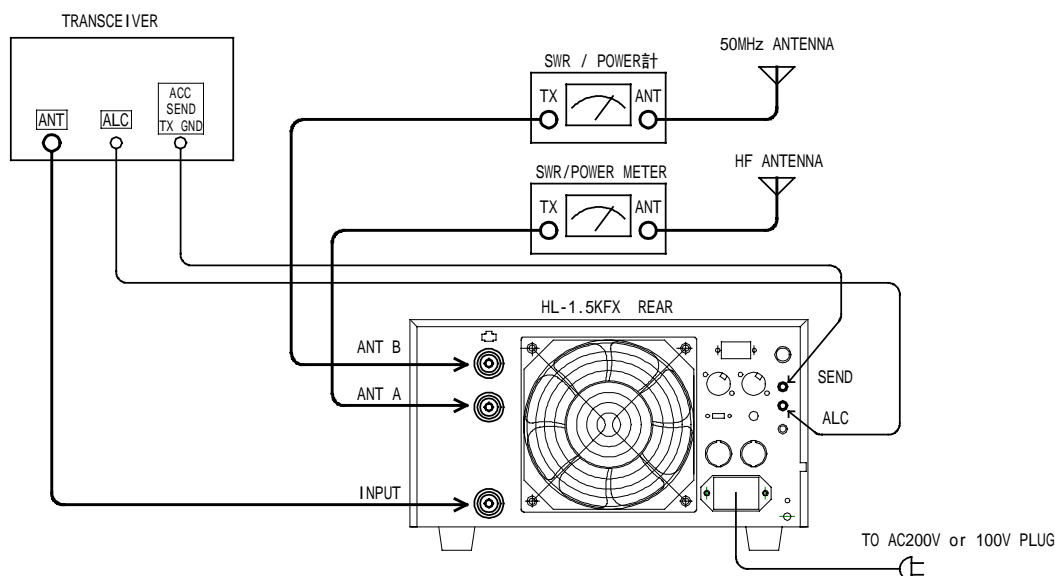

7-1 Connect AC cord and coax cables as illustrated above. Connect the cable from "SEND" to ACC or the remote terminals of transceiver, where it is marked "SEND" or "TX GND". These terminal pins are shorted to ground when the transceiver is in TX/ON AIR mode. If these connections are not made, the amplifier will not go into TX (amplification) mode. For a temporary check to the amp, ground the SEND center pin by inserting an RCA plug whose center pin has been soldered to the outer case of the plug with a small piece of wire. As a side note, this SEND terminal is pulled up to a DC 5V level that is connected to an internal microprocessor pin. When grounded, DC sink current of 1 mA (only) will flow. The transceiver's control circuit is under a very light load.

7-2 At first, turn the ALC knob full clockwise to avoid ALC voltage to the transceiver. Application of ALC will be covered in the following section 8.

7-3 Keeping the POWER (AC mains) switch off, check the SWR of your antenna by keying the transceiver to TX mode (CW or RTTY mode). Monitor the SWR with an external SWR/Power meter. If SWR is 1.8 or higher at band center, the antenna has to be adjusted for lower SWR. As an alternative, an antenna tuner may be inserted.

7-4 Turn the POWER switch on. Turn the BAND switch to MANUAL position. Then push UP/ DOWN keys to select desired band. Turn the STAND-BY switch to OPER (operate) position and the amplifier is ready to go. If you key the transceiver with the carrier level set relatively low (such as 20-30W), you will achieve an amplified output signal of a few hundreds watts. Monitor this output with the multimeter in the (Pf position) or with an external power meter. Increase drive level to roughly 50W and see if the antenna SWR stays constant. (As higher RF currents flow some antennas may show a changed SWR value due to heated connector junctions and trap coils.)

7-5 You can now increase the drive level to nearly 80-90W to achieve maximum carrier output power of 900W (CW, RTTY) from the amplifier. If you change to SSB mode, peak voice power will reach approximately 1kW. For high duty cycle transmissions like RTTY, SSTV, or FM modes, it is recommended you reduce the drive power by 20-30% compared with SSB/CW. In AM mode, the drive power should be strictly reduced to one third of SSB, or 30W at most, otherwise modulated amplitude peaks will be distorted.

7-6 With a high power transceiver in SSB mode, you can overdrive the amplifier resulting in a distorted output signal. This can also occur if you speak too loud or if you set the microphone gain too high. Speak into the microphone properly to reduce the possibilities of splattering into the neighborhood. The ALC is effective in preventing the output signal from being distorted or to limit the carrier level to within rated output levels. As long as you do not overdrive, you can disregard the ALC connection. See Section 8, ALC CONNECTION for details.

7-7 Protection circuits may work during operation depending on the conditions. If the protection circuit

has shut down the amplifier, check the antenna SWR, Vd , AC line voltage, or try to reduce the drive level. To reset, turn off the POWER switch once, then back on again. The power transformer has an overheat protection in the coil layer. If this temperature switch activates, the amplifier will put you in receive mode with the cooling fan operating until the transformer has cooled off. It may take ten to fifteen minutes to cool, depending upon room temperature. For more details on this protection circuit, see Section 10.

8. ALC Connection

ALC voltage is available at the terminal marked ALC (RCA phono jack) on the right upper corner of the rear panel. Negative maximum DC voltage of ten volts (- 10V) is produced at this terminal when the amplifier is fully driven. This voltage is adjustable with the ALC ADJ. knob located above the ALC jack. If the ALC voltage is properly fed back to the transceiver, we advised you to keep the maximum output power constant or hold the power at a certain level. Also ALC is useful in avoiding your SSB signal from being distorted when overdriven. You may not always need to connect ALC to the transceiver, if you set the mic gain properly and do not overdrive the amplifier. Depending upon the manufacturer of the transceiver, the suitable ALC voltage differs. ICOM may need 0~ -4V, and Yaesu may need 0~ -5V range. Kenwood may need -6 ~ -8V maximum. Check your transceiver manual.

8-1 Prepare an ALC control cable using the RCA plug supplied in the package. Solder a single wire or (more preferably) a shielded single wire to the center pin of RCA plug and solder the shield braid to the outer side of the plug. Connect the control cable to the "ALC (or EXTERNAL ALC)" jack of the transceiver. External ALC input is sometimes available at one of the pins of the "ACC" socket of the transceiver as well.

8-2 At first, turn ALC ADJ. full clockwise. Drive the amplifier in CW/RTTY mode to full output power. Then turn the ALC ADJ counter-clockwise. Observe the SWR/Power meter at the output, (or Pf of the multimeter). Stop turning the ALC ADJ at the point the power starts to decrease. Or if you wish to further reduce the power, keep turning ALC ADJ until the desired level is achieved. If you further try to increase the drive power you will now see the output power become rather saturated, from these adjustments,

(Maximum ALC voltage produced is -10V when the amplifier output is over 200W.)

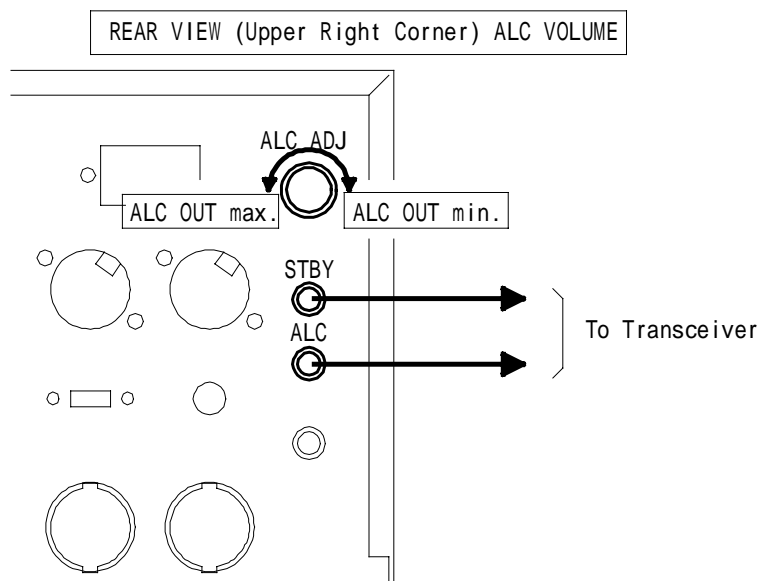

9. Band Data Cable Connection

Connection methods with ICOM, Yaesu and Kenwood transceivers are described here in detail respectively. This connection enables the automatic band setting of the amplifier with the band set command from the transceiver. Four types of cable connections are explained.

9-1 ICOM DC Voltage Band Data

For your safety, please turn off the power (AC) to both the transceiver and amplifier. Connect the cable (for ICOM DC Voltage Band Data Connection) as shown in the following illustration.

Slide the "BAND DECODE" slide switch on the rear panel toward "ICOM". (Other side is for CI-V.)

Set the "BAND SELECT" rotary switch on the front panel to "ICOM". Now turn on the AC to the transceiver, and then turn the POWER switch to the amplifier on. Observe that the band indicator (LED) of the amplifier matches that of the transceiver.

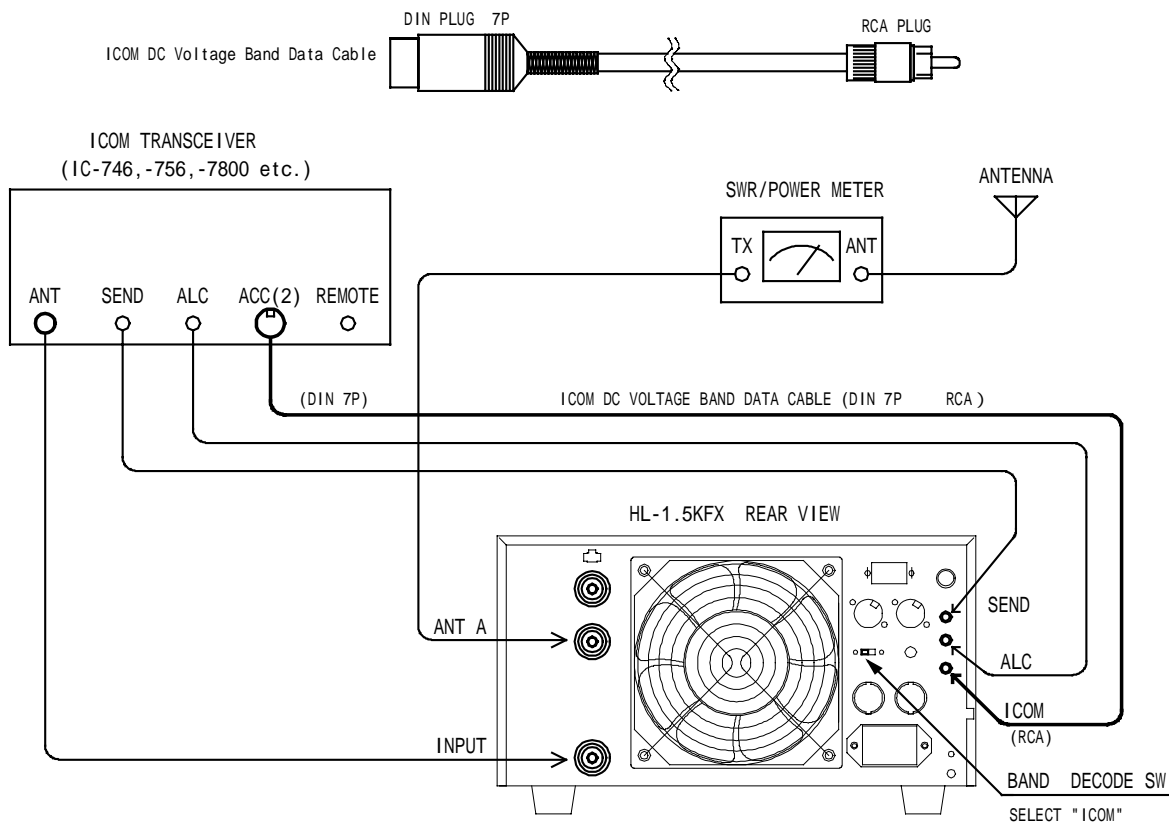

Note : This connection is for ICOM models of 746, 756, 7800 etc. (706MK II G & 7000 need a special connection to the ACC socket using the ICOM supplied accessory cable assembly. See the 706/7000 manual). IC-7700 is to be connected to CI-V terminal.

9-2 ICOM CI-V

The following initial settings are needed on the ICOM transceiver ;

CI-V BAUDT RATE : 9600
CI-V ADDRESS : 5ch
CI-V TRANSCEIVER : ON
CI-V with IC-731 : OFF

(For details, refer to your ICOM radio manual.)

Turn off the power (AC) to both the transceiver and amplifier. Connect the following CI-V band data cable as shown in the illustration.

Slide the BAND DECODE switch knob to the CI-V side. BAND SELECT rotary switch on the front panel should be set to the ICOM position.

Make sure the transceiver is in receive mode. Turn on the POWER switches to the transceiver and the amplifier. Observe that the band indicator (LED) of the amplifier matches that of the transceiver.

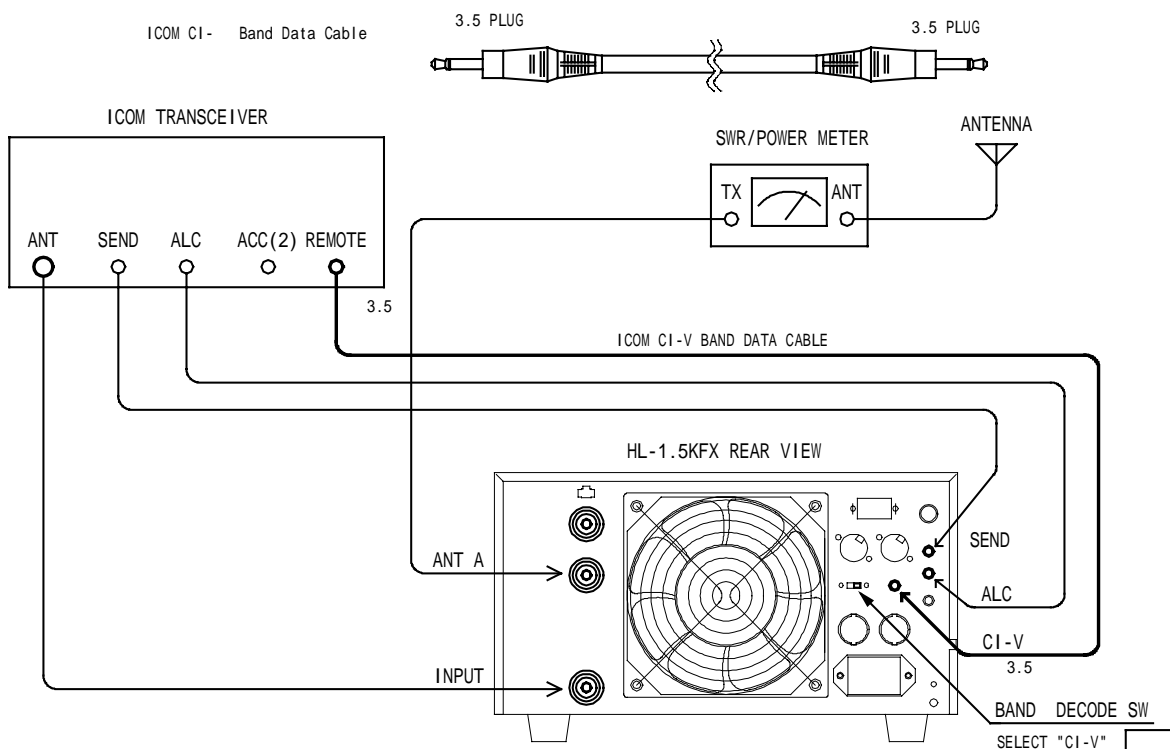

9-3 Yaesu Band Data

Using the Yaesu band data connection cable (shown below), connect the transceiver (example, FT-1000MP MK-V) to the HL-1.5KFX.

Turn off the AC POWER to the transceiver and the amplifier. Connect the 8 pin DIN plug to the BAND DATA (8 pin) socket of the Yaesu transceiver. Connect the other end, the 5 pin DIN plug to the YAESU of 5 pin DIN socket on the rear panel of the amplifier.

Check and make sure that the transceiver is in receive mode. Power up the transceiver and then turn on the AC POWER to the amplifier. Observe that the band indicator (LED) of the amplifier matches that of the transceiver.

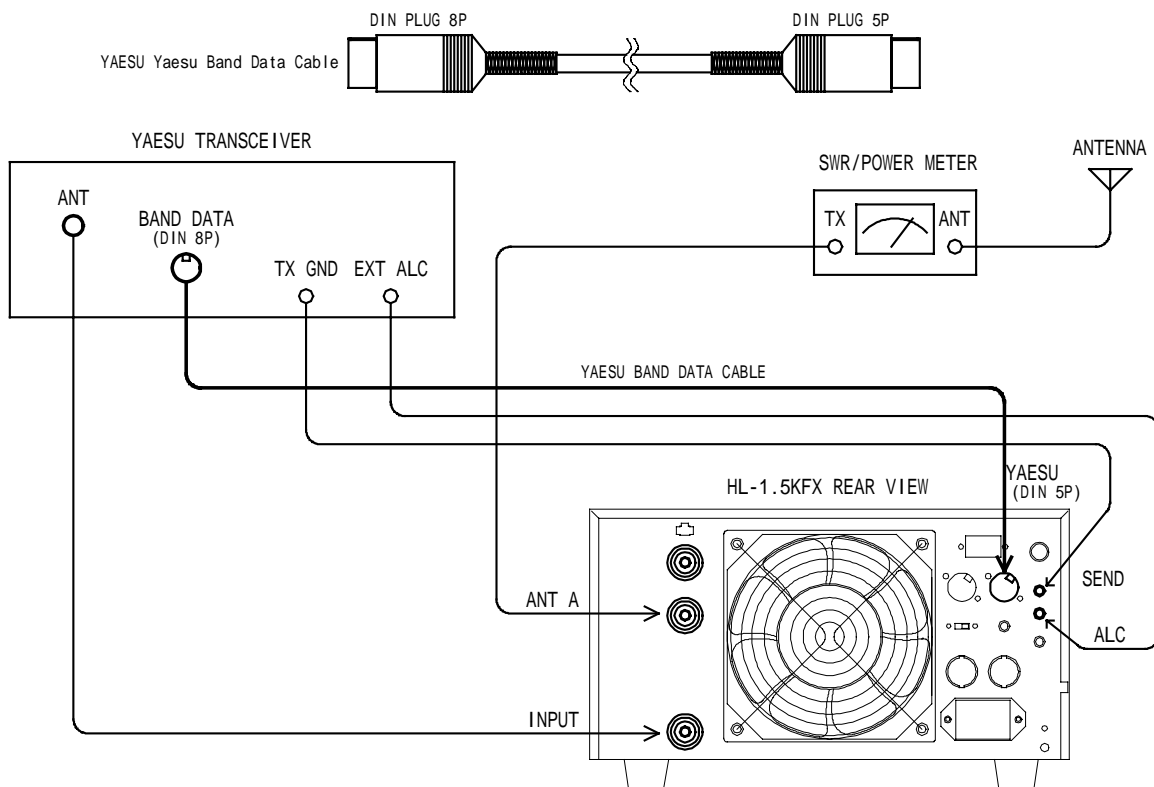

9-4 Kenwood RS-232C Band Data

Using the Kenwood band data connection cable (shown below), connect the transceiver (example TS-950, TS-870) to the HL-1.5KFX as illustrated below.

Initial settings for the transceiver are as follows :

Communication Speed : 9600 (bps)

Stop Bit : 1 bit

(Refer to the Kenwood radio manual for more details).

Turn off the AC POWER to the transceiver and the amplifier. Connect the D-SUB (9 pin) plug to the COM (D-SUB 9 pin socket) on the rear panel of the Kenwood transceiver. Connect the other D-sub 9 pin plug to the KENWOOD (D-SUB 9 pin socket) on the rear panel of the amplifier.

Check that the transceiver is in receive mode. Turn on the AC POWER to the transceiver and the amplifier. Observe that the band indicator (LED) of the amplifier matches that of the transceiver.

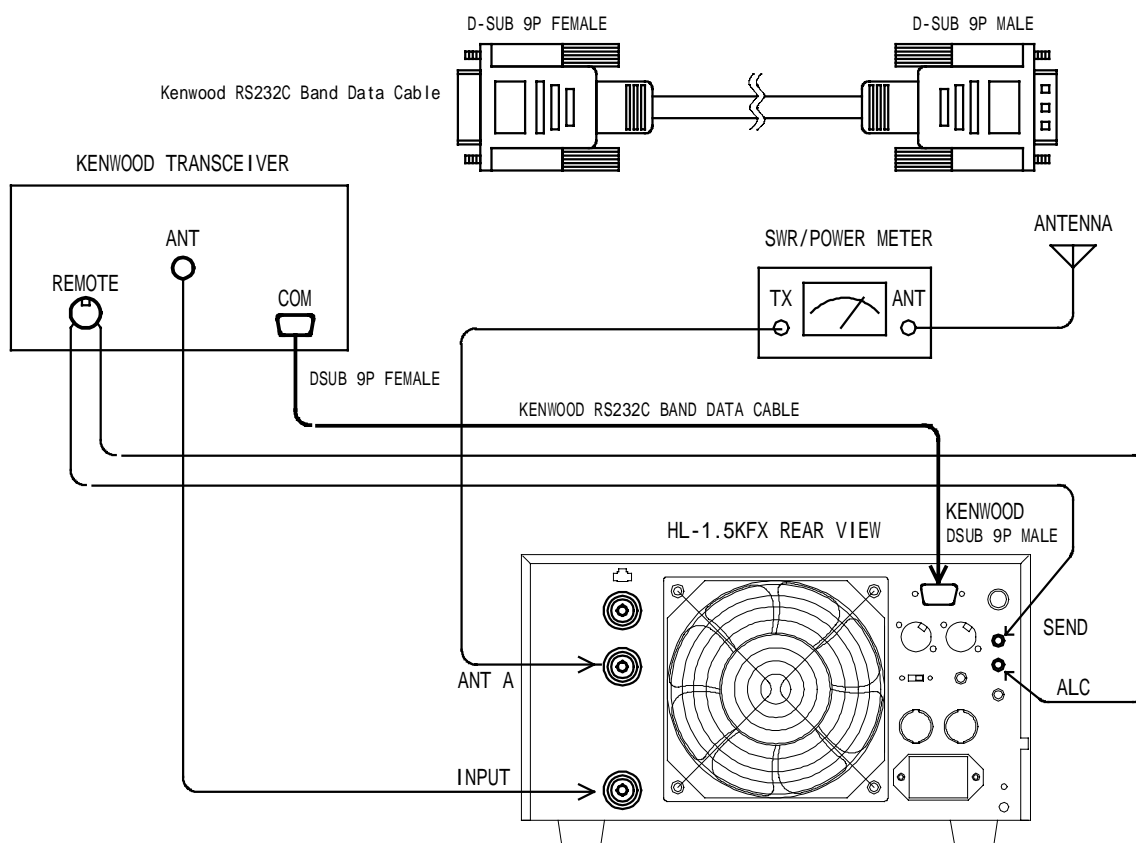

10. Protection Circuits

There are five major protection functions in this amplifier. If the amplifier has shut down for some reason, before re-setting, correct the possible cause of the shut down. Turn off the POWER once and back on to reset.

10-1 O.DRIVE (Over Drive/ Band Miss-set)

When the drive power exceeds the 100W level, the amplifier will shut down to STAND-BY mode (or receive) in order to protect the input side of the power FET's. This protection might also activate if the band is set wrong. This usually occurs, in MANUAL BAND mode, when the amplifier band setting is lower than that of the transceiver. To comply with FCC rules any RF between 26.0-28.0MHz will cause Amplifier to shut down and not operate.

10-2 O.HEAT (Over Heat)

When the temperature of the aluminum heat sink in the power amplifier reaches 70 degrees C, the amplifier defaults to RECEIVE mode to protect the power FET's. Likewise, if the temperature of the inside layer of the power transformer reaches 130 deg. C, the amplifier will default to RECEIVE mode for your safety. O.HEAT protection cannot be reset until the heat sink or transformer has sufficiently cooled off.

10-3 O.VOLT (Over Voltage)

If there is a sudden AC line voltage spike, or if the transformer primary develops a fault, the FET drain voltage may rise above acceptable levels. If O.VOLT protection trips, check the AC line voltage with a circuit tester or an AC voltmeter.

10-4 FUSE (Fuse Blown)

If either of the glass fuses (20A) on PC1662V fails, O.VOLT protection activates. Under normal usage of the amplifier, this failure should rarely (if ever) occur. If it occurs, there is a possibility that the power FET's have failed together. If the amplifier cannot be reset, consult with the dealer or the service center.

10-5 PR (Reflected Power Protection)

If reflected power because of the antenna reaches approximately 80W, the PR protection may trip. If it does, one solution is to reduce the drive power from the transceiver. Or you may need to check that your antenna match (SWR) is still ok. If the match cannot be corrected and the antenna system isn't faulty, use an antenna tuner.

As noted above, the amplifier is equipped with several kinds of fast acting protection circuits using the latest in microprocessor technology. However, if the amplifier is operated in such a manner that multiple protections work repeatedly over a long period of time, the amplifier can be seriously damaged.

11. Explanation of Major Circuits

Five major circuit blocks are explained in their basic form and using signal flows.

- 11-1 Main DC Power Supply
- 11-2 Power Amp, L.P.F.
- 11-3 RF Power Detector, TX/RX Switching
- 11-4 Main Controller
- 11-5 Band Decoder, Frequency Counting

11-1 Main DC Power Supply

The main DC power supply feeds the 50V DC power to the final PA stage. It is a non-regulated power supply and consists of the compact power transformer using an oriented core, a bridge diode rectifier, and a high capacity electrolytic capacitor of 68,000uF for the filter. A soft start circuit suppresses the AC rush current using a thyristor. A part of 50V line is converted to 24V using a DC-DC converter and is supplied to the cooling fan.

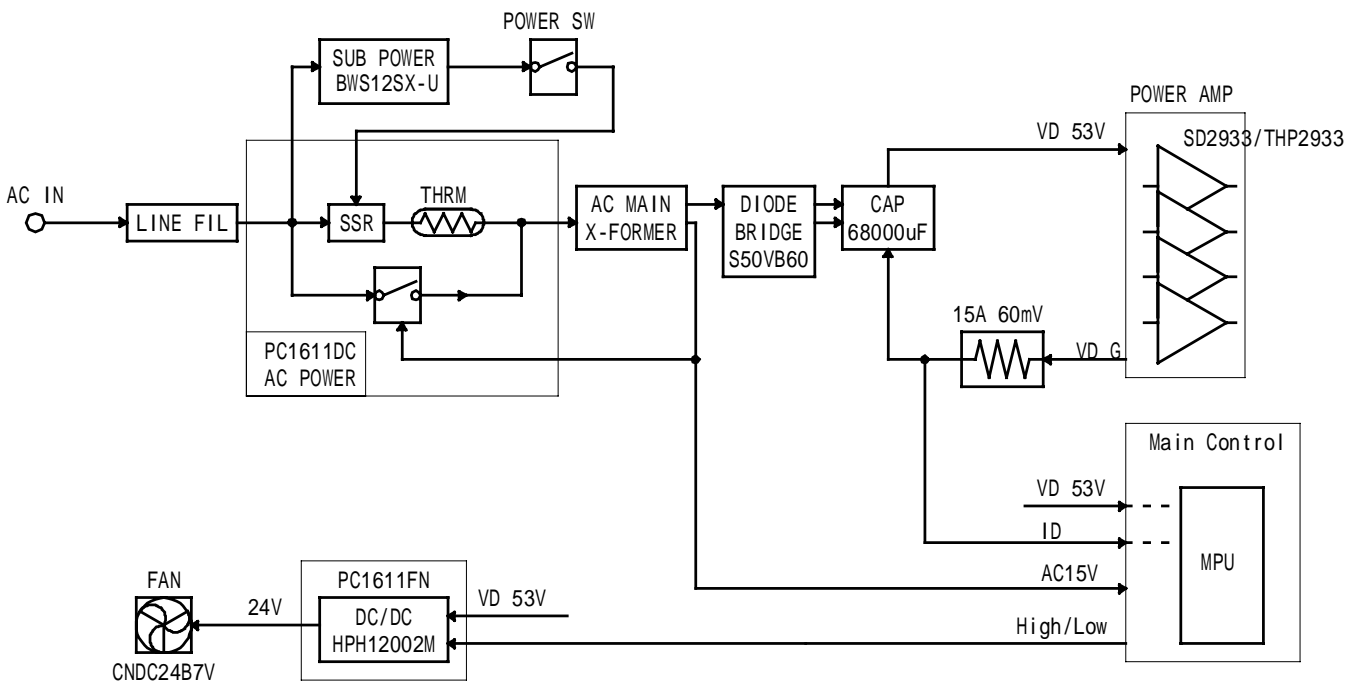

11-2 Power Amp (PA PC1662V) / L.P.F. (PC1681)

The RF PA is the heart of this amplifier and is composed of four SD2933 / THP2933 MOS FET's. The amplifier is a parallel push-pull type of class AB amplifier. The gate bias supply circuit is regulated for the best stability and is thermally compensated.

The PA has a 6dB attenuator on the input for gain reduction and to enhance the stability of the wide band power PA. The heat sink has two different thermal sensors to detect temperatures of 40 deg C, and 70 deg C, respectively. At 40 deg C, the cooling fan shifts into high-speed mode. At 70 deg C, the amplifier will lock the amplifier into RECEIVE mode to protect the power FET's.

In the L.P.F. (output low pass filter) circuit, there are eight different band filters that are selected either by the auto band decoder or by the manual band switch. Each L.P.F. is used to reject harmonics so that the amplifier meets international telecommunication equipment standards.

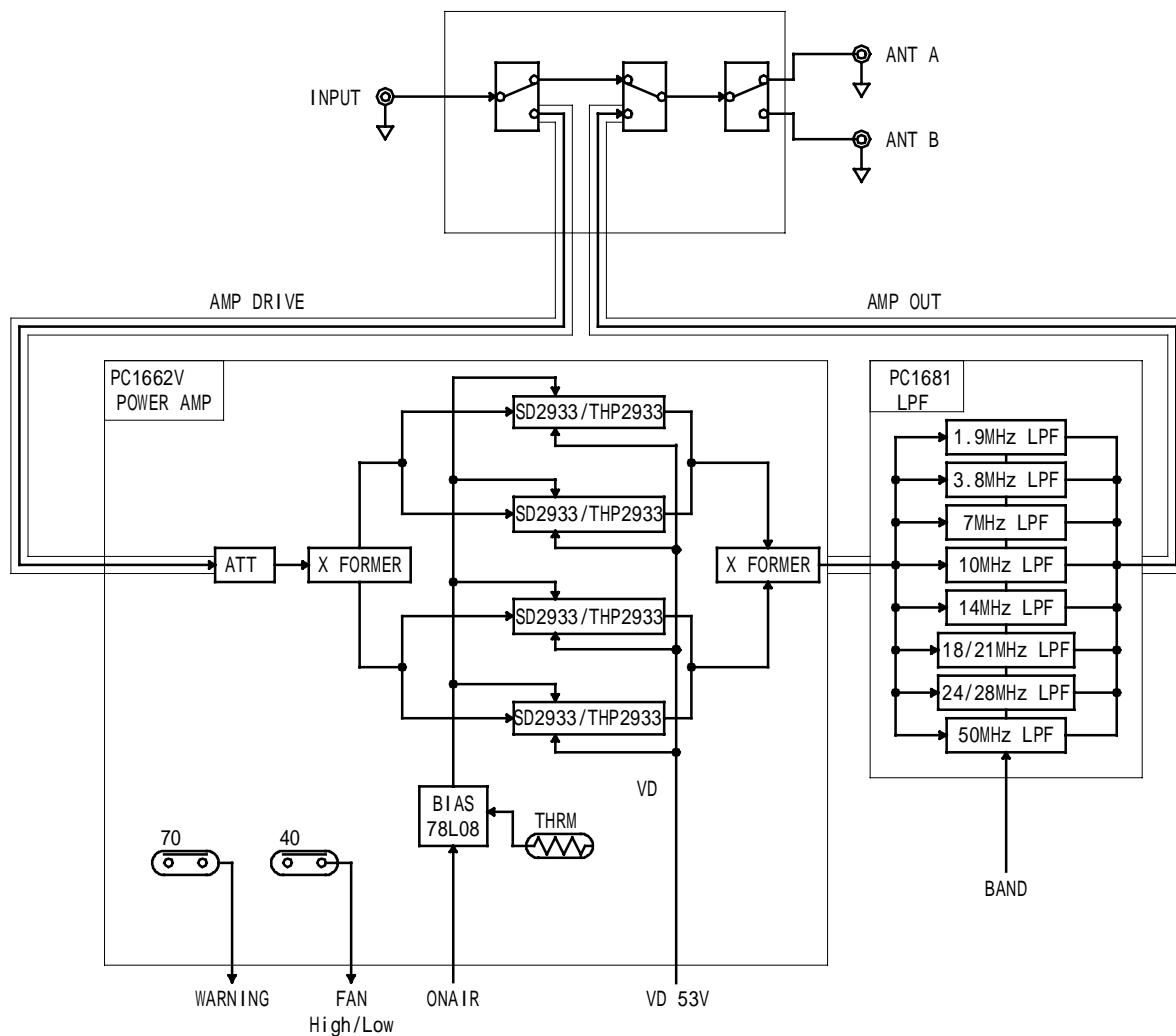

11-3 RF Power Detector/ TX-RX Switch (PC1667)

As illustrated below, there are two RF power detectors on this board. One detects the drive signal level from the radio and the other monitors the outgoing power and the reflected power from the load (antenna). These detected signals are sent to the MPU -PCS1699 Main Control board, which monitors the operating condition of the entire amplifier.

The TX-RX switch (Send-Receive switching) will switch the flow of drive power/ output power and the incoming signal from the antenna with two high-speed relays mounted at the input and output sides of the PA. A two-channel antenna switch (A/B) is also installed on this main board.

The limiter on this board, together with the pre-scaler on PC1675, help the MPU on the Main Control to count the frequency of the RF drive signal.

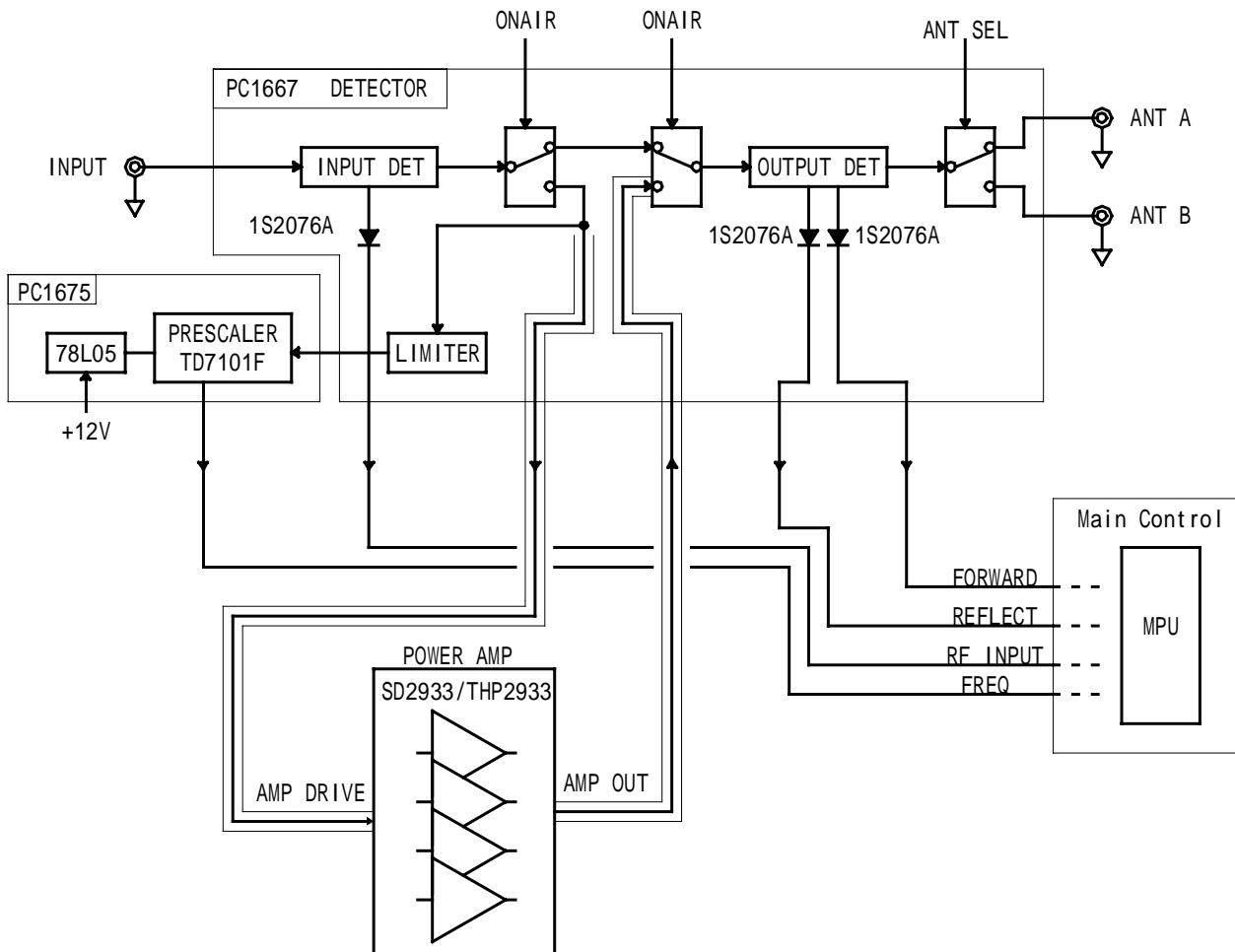

11-4 Main Control (PCS1699)

This is the heart of the control signal processing for the HL-1.5KFX. It judges the operating condition of the amplifier, as well as issuing the commands to the peripheral circuits. Various analog signals are sent to the MPU such as RF drive from the transceiver, RF power signals at various points, DC power supply information, etc.

These are converted to digital signals using a A/D converter. The MPU will then numerically compute the data, to determine the amplifier status, and issue commands for protections, as needed.

Transmit-Receive switching, high/low control of fan, and which LED get lit are all performed by the MPU on this board.

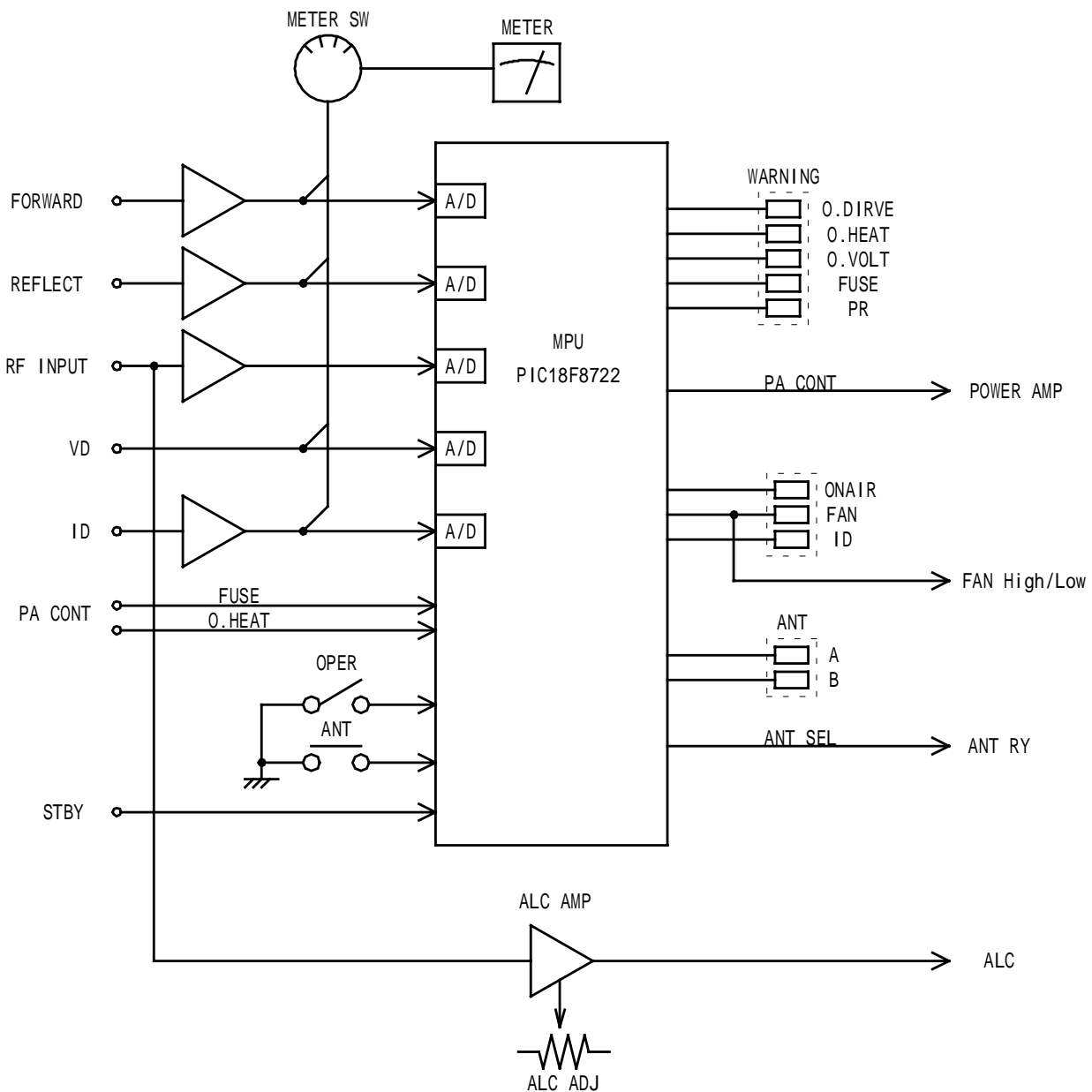

11-5 Band Decoder/ Frequency Counter

The band decoder will decode the various operating band information as issued by the major brands of the radios (ICOM, Yaesu, Kenwood). Using the decoded signal, the amplifier will automatically determine the frequency band of the radio.

From these three manufacturers, there are four kinds of band data used in their latest radio models, i.e. DC voltage, 4-bit TTL, RS-232C, and serial data. The HL-1.5KFX is designed to be able to use any of these methods, when the matched cable is connected.

The MPU also performs a frequency counting function. The RF drive signal from the transceiver is sampled and divided by 16 (PC1675), this signal is then sent to the input of the MPU.

In the manual band select mode, if the frequency of the RF drive and band setting of the amplifier do not match each other, the MPU will send a band miss-set signal which will force an amplification "halt" command (shut down).

Additionally any RF measured between 26.0-28.0 MHz will immediately shut down amplifier operation.

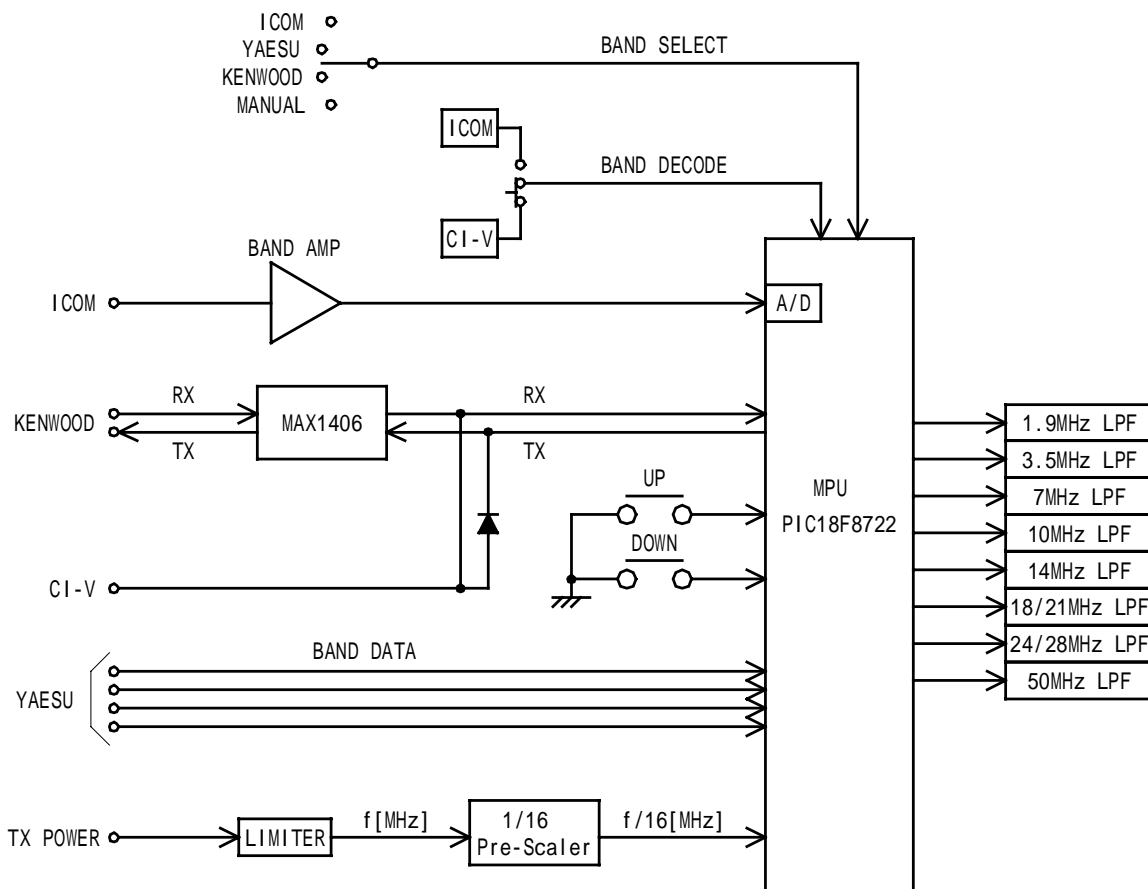

12. Trouble Shooting

Failure	Possible Cause	Solution
AC mains not operating	AC fuses blown AC cord not plugged in Interlock switch lifting Wrong tap used on power transformer primary	Replace with new ones. Plug in securely. Screw bolts tightly on the top cover. Correct primary wiring.
Can't enter Transmit mode	Remote control cable not connected Protection circuits on.	Check the cable and connect properly. Check drive power, antenna SWR, antenna selector A/B. Reset with AC POWER switch.
O.Drive lights	RF overdrive Band miss-set	Decrease drive. Match the BAND correctly (Manual mode)
PR lights	Reflected power high, Antenna SWR high Poor connection to coax cables	Check/ adjust antenna. (Or decrease drive.) Check the coax cable connectors.
FUSE lights	Fuse blown Antenna SWR high Short circuit	Replace F202 and F203 (20A) on the PA board (PC1662V). Adjust the antenna. Contact the distributor, or service center.
O.Heat lights	Internal Temperature above 70deg. C	Cool off until LED turns off. Check for air intake blockages. Also check air vent on top cover.
TVI, FMI	Overdrive. RF leakage from coax cable, grounding wire, AC power cord etc.	Decrease the drive. Check ALC setting. Insert common mode filters on antenna cable or AC line. Add clamp-on ferrite cores (TDK, Amidon, Palomar) on various cables.

APPENDIX

Auto Band Set Compatibility, Tokyo Hy-Power HL-1.5KFX For Three Major Japanese Brand Radios

1. ICOM

ICOM CI-V

According to ICOM, any radio model manufactured in 1987 or thereafter is equipped with CI-V. Consequently most of ICOM's owned by the user now work "Auto Band Set" through CI-V.

ICOM DC VOLTAGE BAND DATA

Following models are equipped with DIN sockets to supply HL-1.5KFX with DC voltage band data as well as CI-V.

IC-736, -746, -756, -756Pro, -756ProII, -756ProIII, -7400, -775DX II, -780, -7700, -7800

(IC-706MK II series, and -7000 need modification for DC VOLTAGE BAND DATA CABLE connector, See ICOM manual)

2. YAESU (Binary Coded Voltage)

FT-920, -1000D, -1000MP, -1000MP MKV, -2000, -DX9000

(FT-857D, -897D and -950 need modified special Yaesu Band Data Cable and/or Cable Adaptor. Contact HRO or Tokyo Hy-Power Head Office, Japan.)

3. KENWOOD (RS-232C Serial Data)

To our regret, there are only three models available that has RS-232C port. Kenwood says old popular models such as TS-950, -940 are not equipped with these features.

TS-870S, TS-480, TS-2000

(Some Kenwood owners may wish to use RS232C port for PC controlled logging purposes. In this case, the user will need a Y-shaped special 232C cable, that has two D-Sub plugs in parallel on one end (one for radio, and one for linear), and one D-Sub plug for PC, where the "TX" line is rather OPEN, and not closed to avoid the double hand shakings. For more details, contact THP.)

4. OTHERS (TEN-TEC and Elecraft K3)

Using the signal data converter, one may connect ORION to Yaesu socket of HL-1.5KFX. The converter IC (such as 74C147) will convert the nine band data of ORION (DC level) into binary codes. Then being polarity inverted through four 74C14 inverter IC, data is sent to 5-PIN DIN sockets of "YAESU". (For more details, please contact THP.)

K3 can be connected to HL-1.5KFX using supplied Yaesu band cable, only if four lines of decimals are connected to DC +5V supply through pull-up resistors (one each 4.7k ohm per each of BCD lines, A, B, C, D.). You may also choose an accessory device for band control solution, such as "STATION MASTER" by MicroHAM. (Visit www.microham-usa.com)

For further questions, please contact the respective manufacturers' USA service center, and/or THP Japan. THP believes above information is accurate and correct. However THP assumes no responsibility for any damage resulting from the connections of the equipments by the users.

Prepared by TokyoHy-Power Labs., Inc.

Website: www.tokyohypower.com / www.thp.co.jp

Email: thpsupport@airmail.net (for USA) / info@thp.co.jp (for other countries)

(Rev. II, Nov. 18th, 2008)

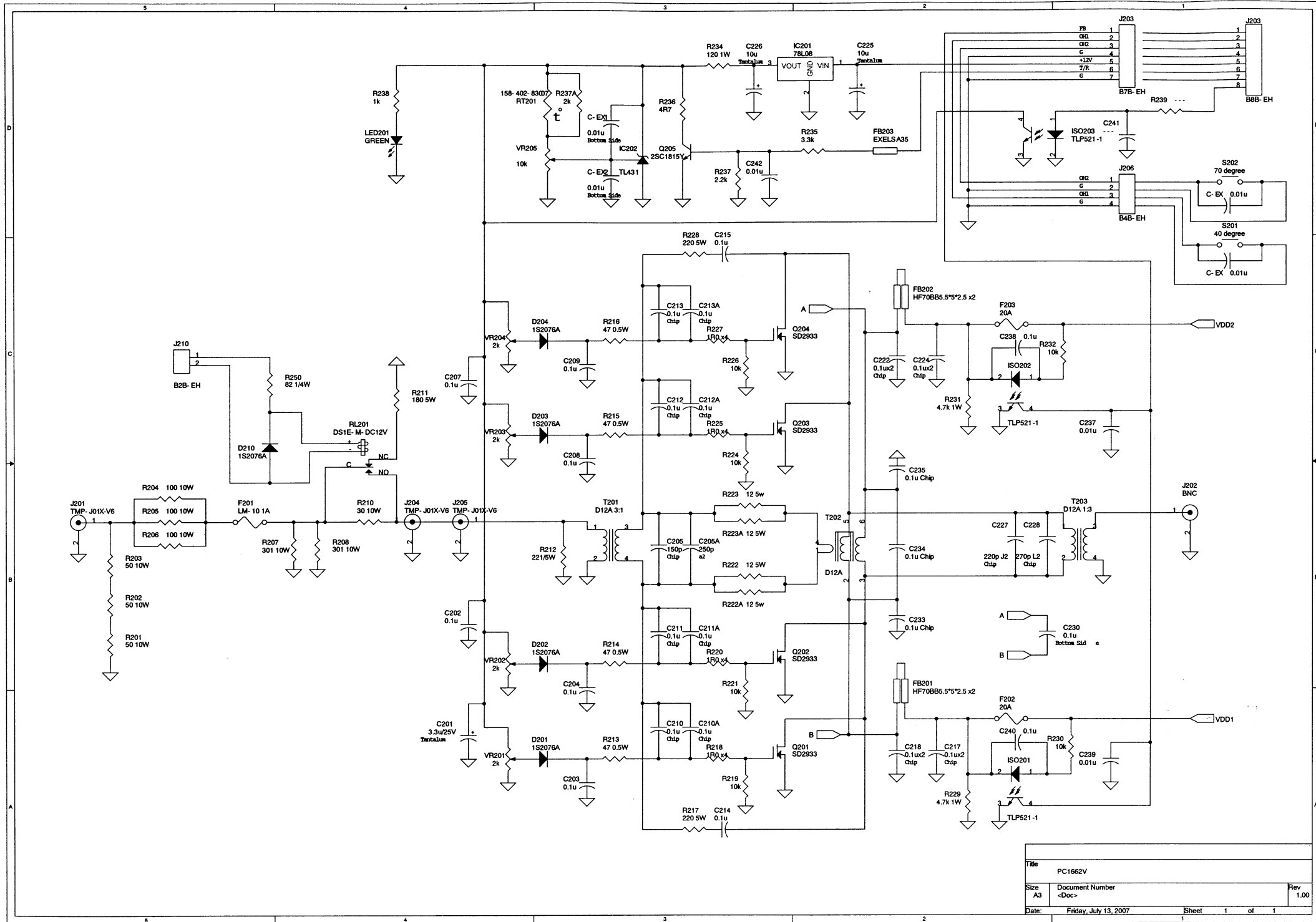

Title	PC1662V	
Size	Document Number	Rev
A3	<Doc>	1.00
Date:	Friday, July 13, 2007	Sheet 1 of 1

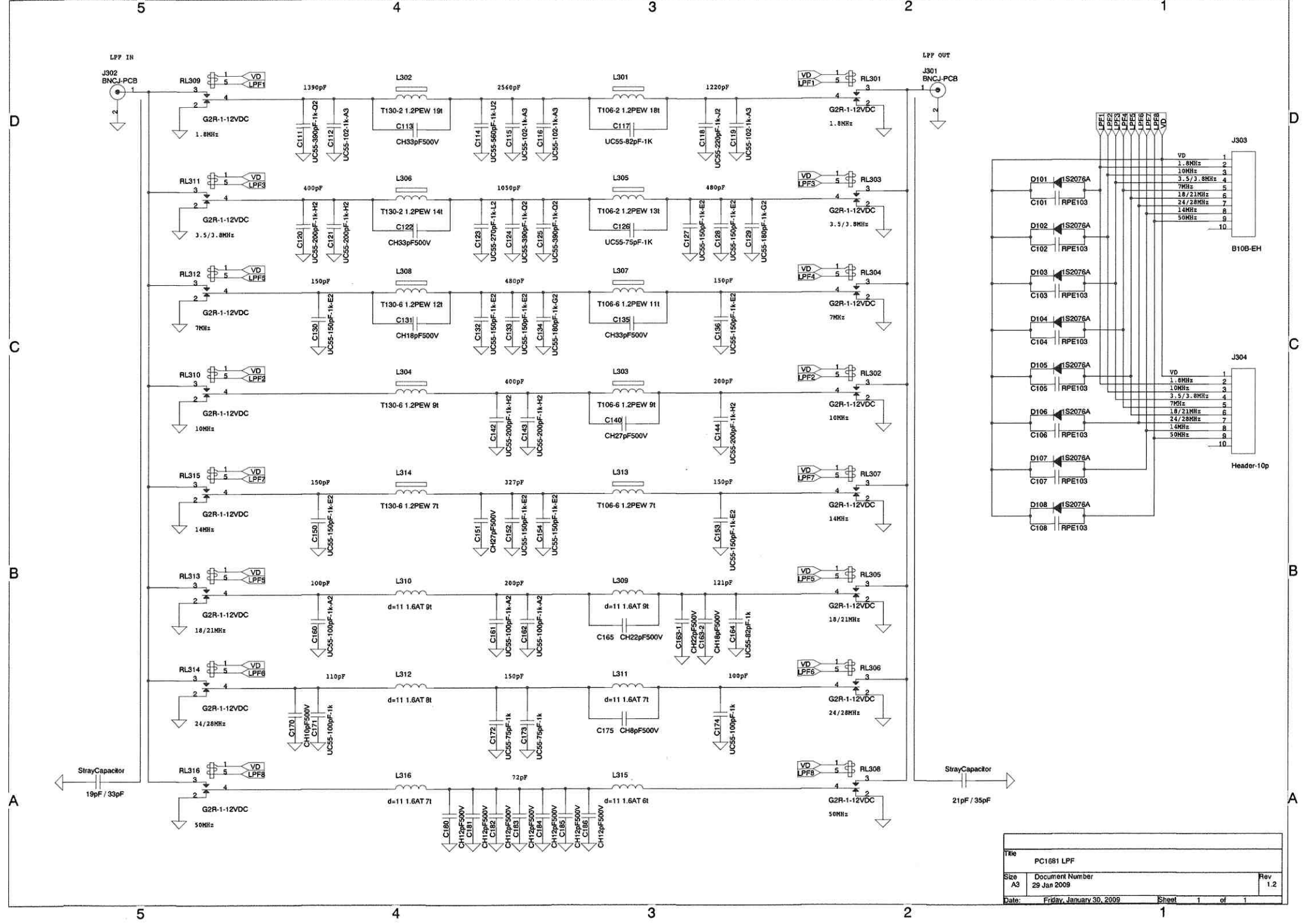

Title		
PC1681 LPF		
Size	Document Number	Rev
A3	29 Jan 2009	1.2
Date:	Friday, January 30, 2009	Sheet 1 of 1

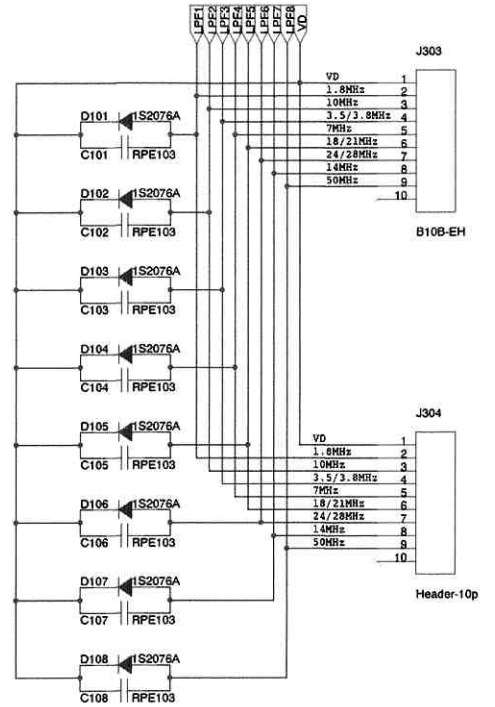

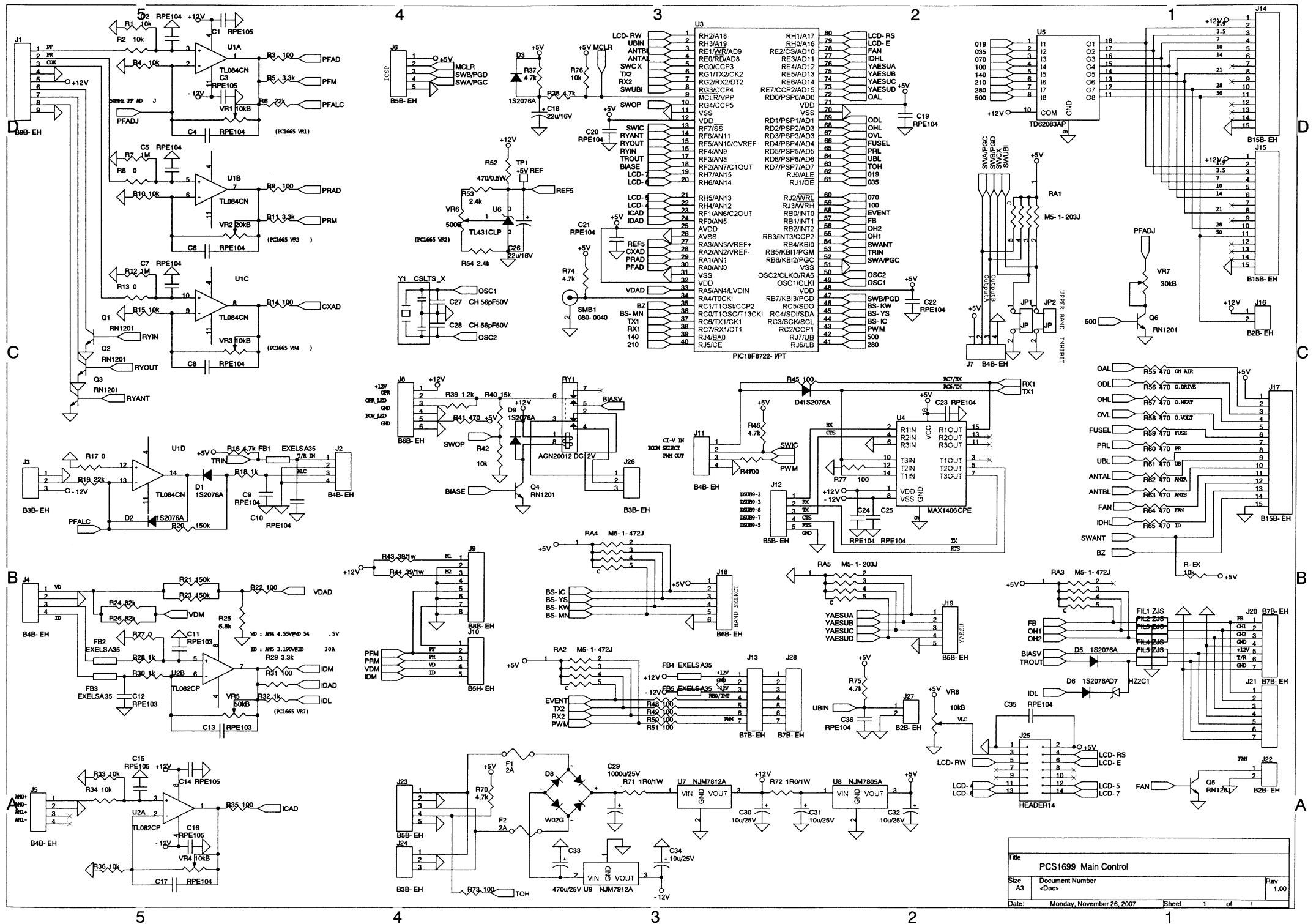

File		
PCS1699 Main Control		
Size	Document Number	Rev
A3	<Doc>	1.00
Date:	Monday, November 26, 2007	Sheet 1 of 1

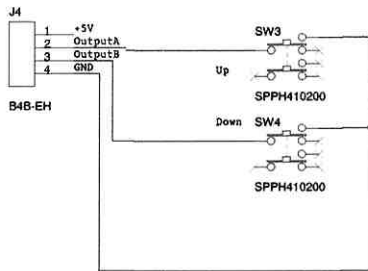
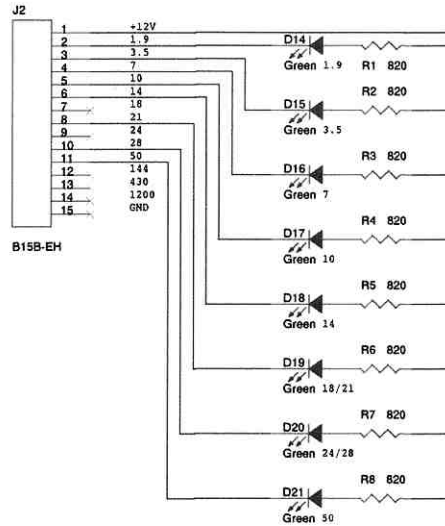
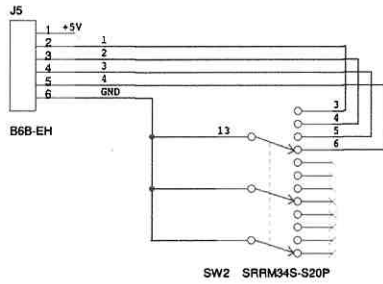
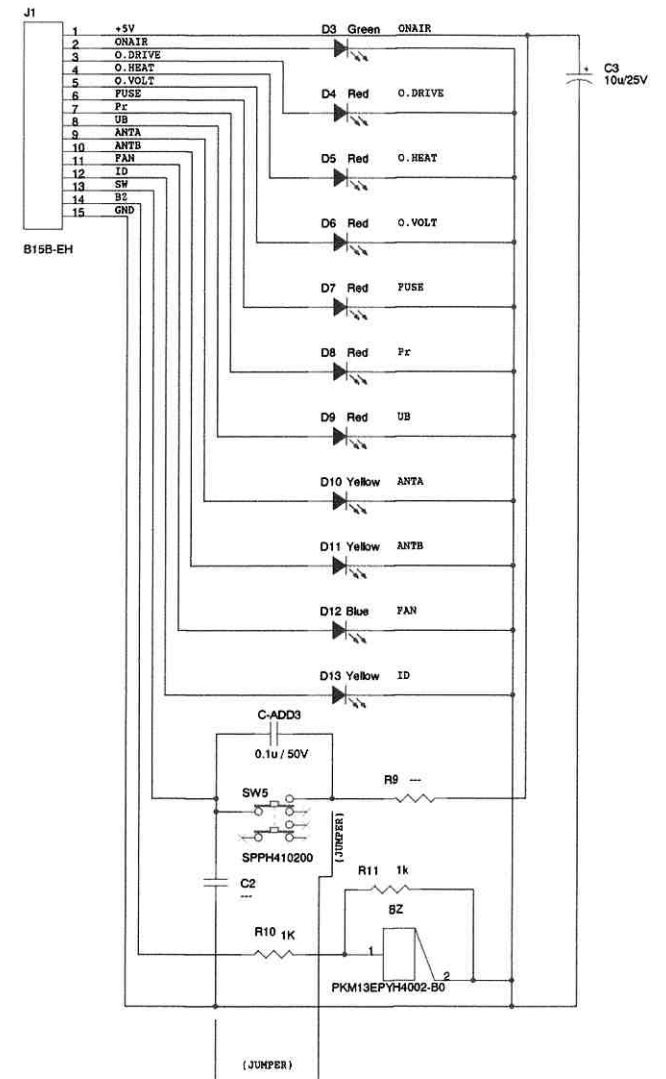
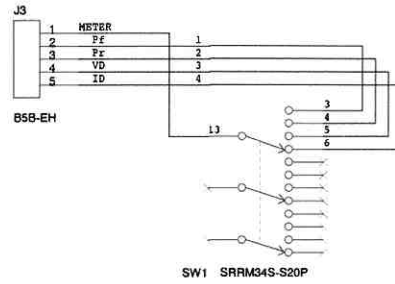
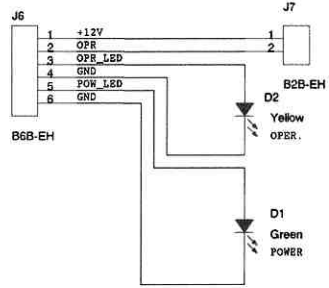

Title		
PC1669 FRONT PANEL BOARD		
Size	Document Number	Rev
A3	29 Jan 2009	1.1
Date:	Friday, January 30, 2009	Sheet 1 of 1

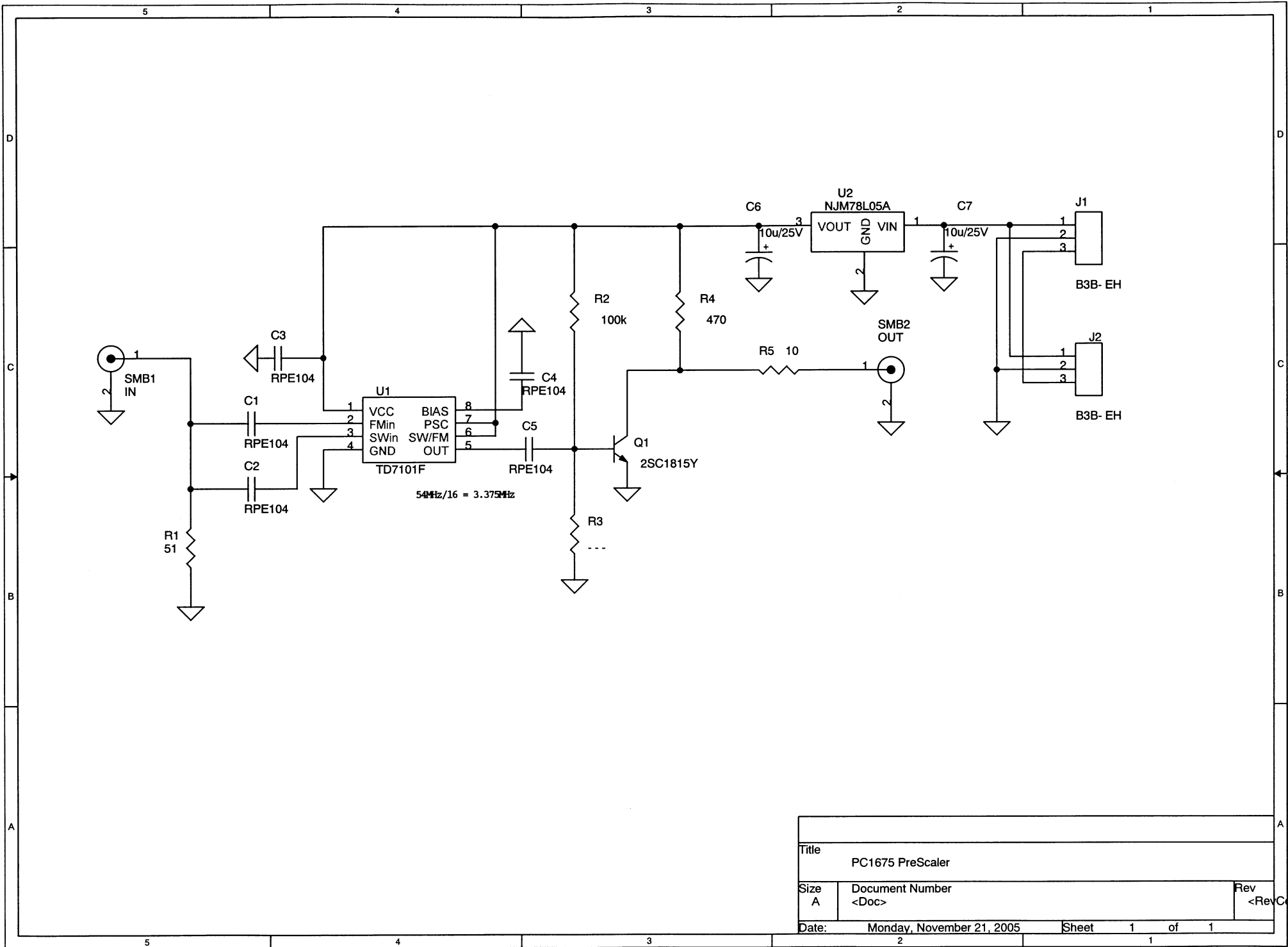

Title		PC1675 PreScaler	
Size	Document Number	Rev	
A	<Doc>	<RevCode>	
Date:	Monday, November 21, 2005	Sheet	1 of 1

5

4

3

2

1

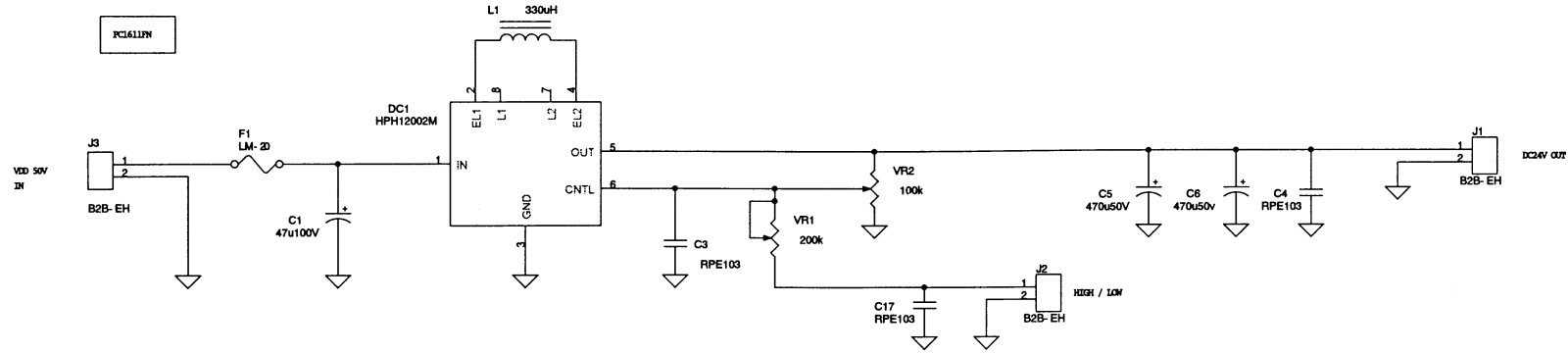

PC1611DC

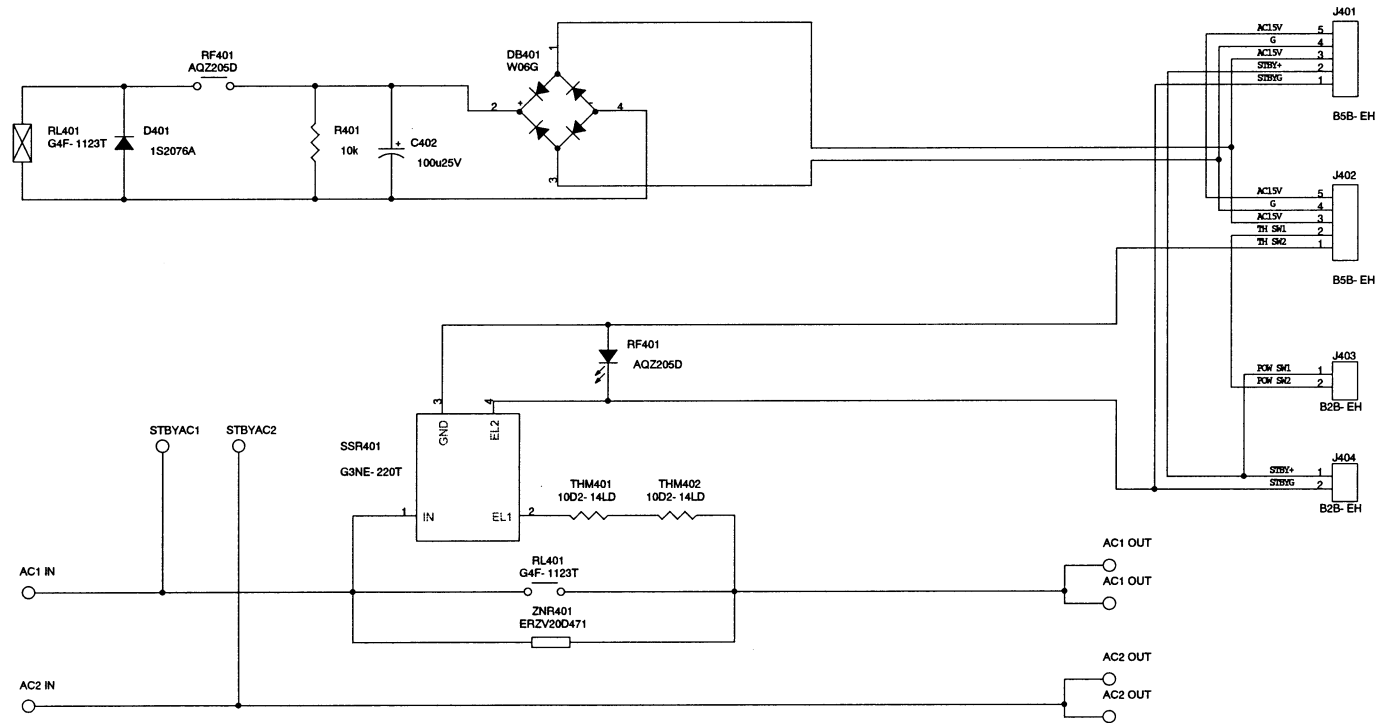

Title		
PC1611FN / PC1611DC		
Size	Document Number	Rev
A3	<Doc>	1.00
Date:	Tuesday, June 05, 2007	Sheet 1 of 1

5

4

3

2

1

D

D

C

C

B

B

A

A

STBY
ALC

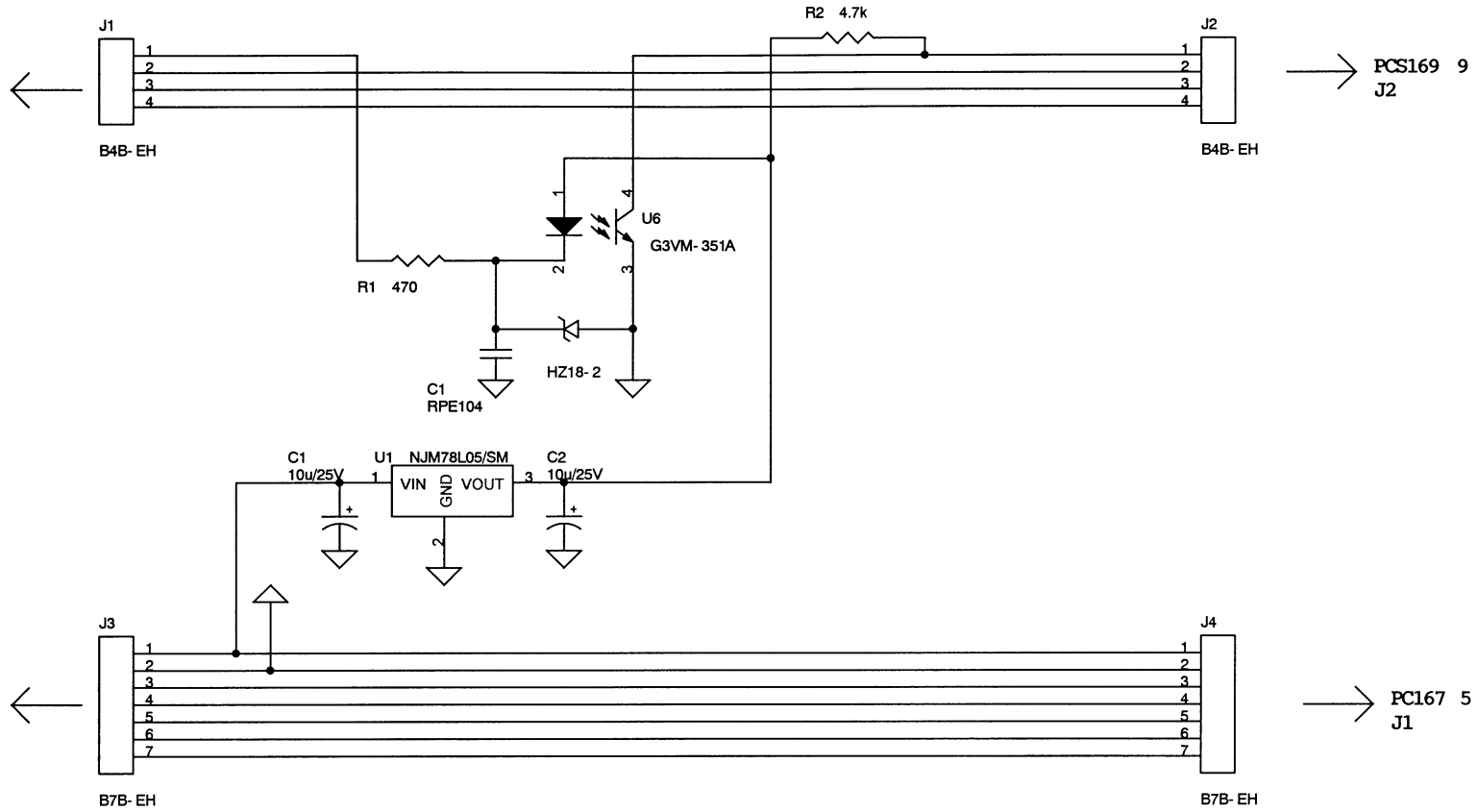

Title		
PCS1750		
Size	Document Number	Rev
A4	<Doc>	<RevCode>
Date:	Wednesday, October 17, 2007	Sheet 1 of 1

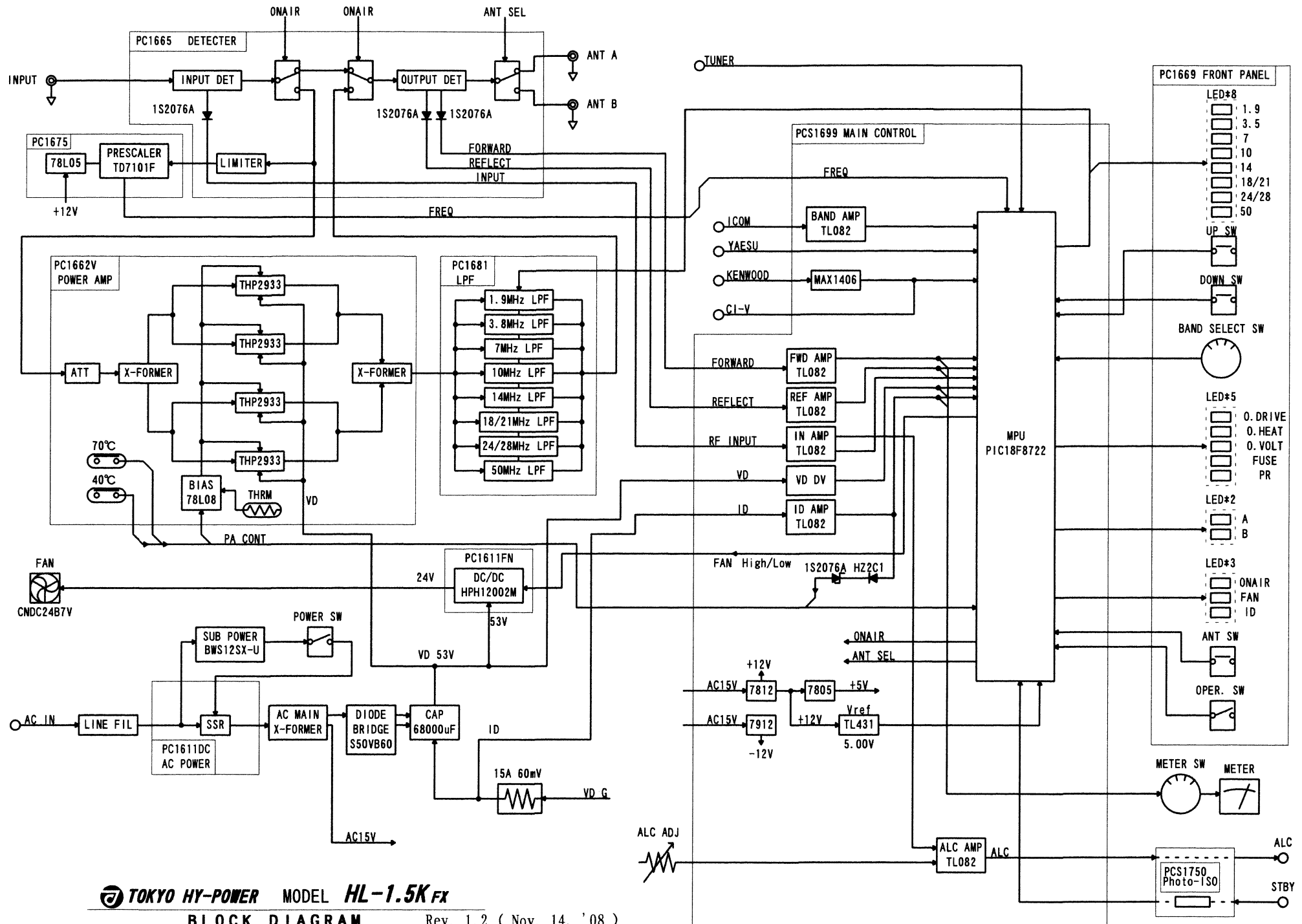

TOKYO HY-POWER MODEL HL-1.5K FX

BLOCK DIAGRAM

Rev. 1.2 (Nov. 14, '08)

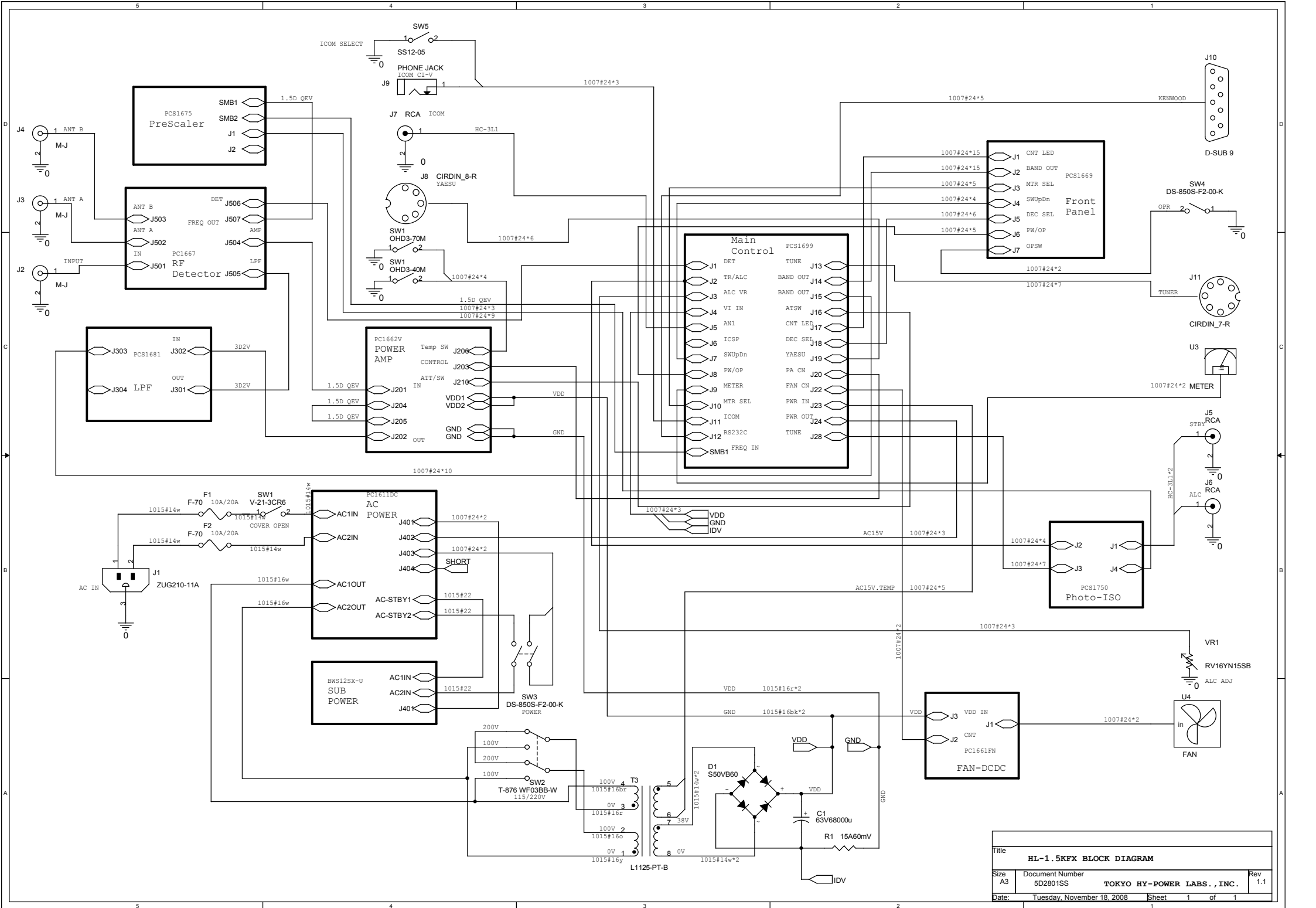

Title			
HL-1.5KFX BLOCK DIAGRAM			
Size	Document Number	TOKYO HY-POWER LABS., INC.	Rev
A3	5D2801SS		1.1
Date:	Tuesday, November 18, 2008	Sheet	1 of 1

15. Parts Layout

15-1 Top View (Detailed)

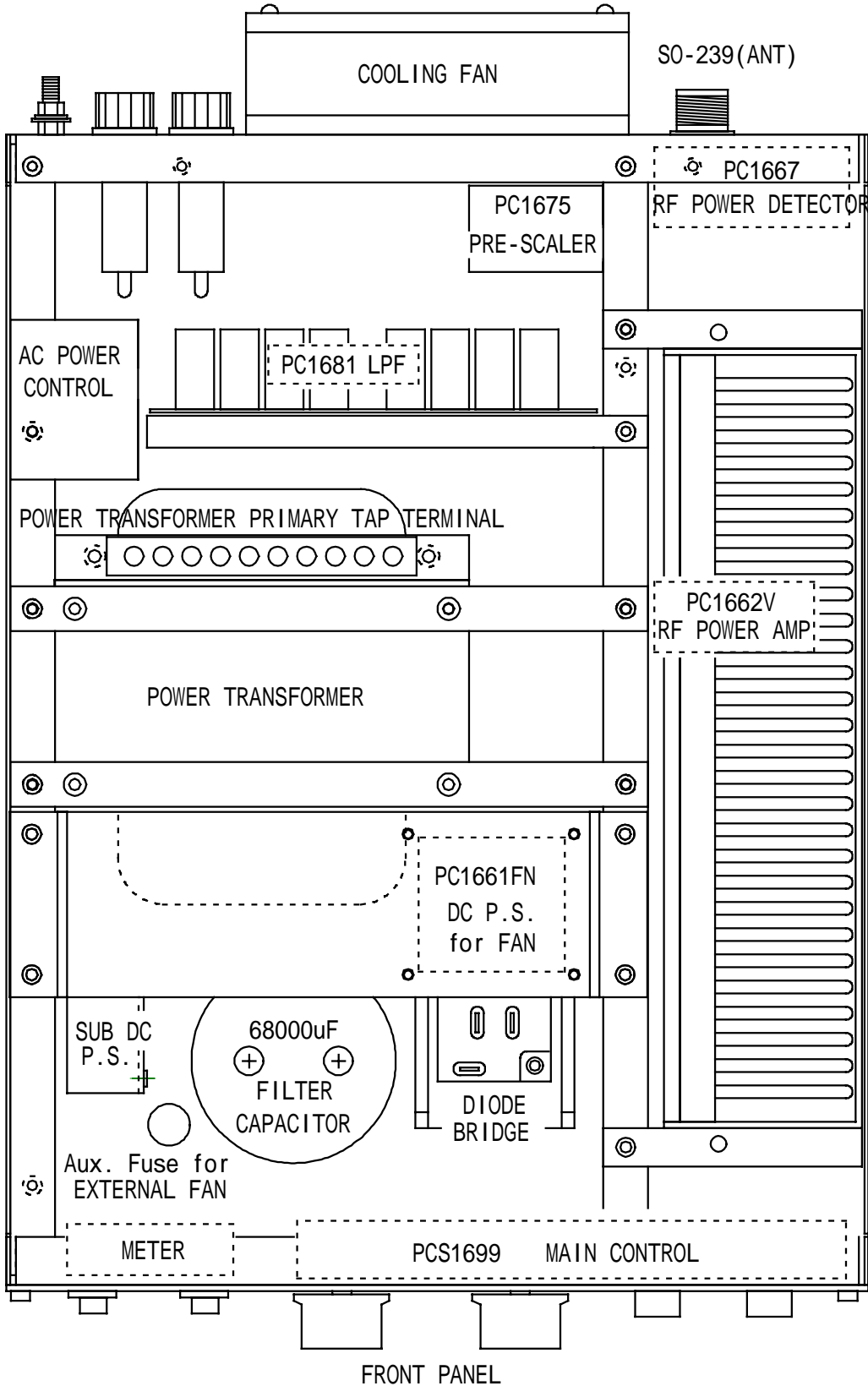

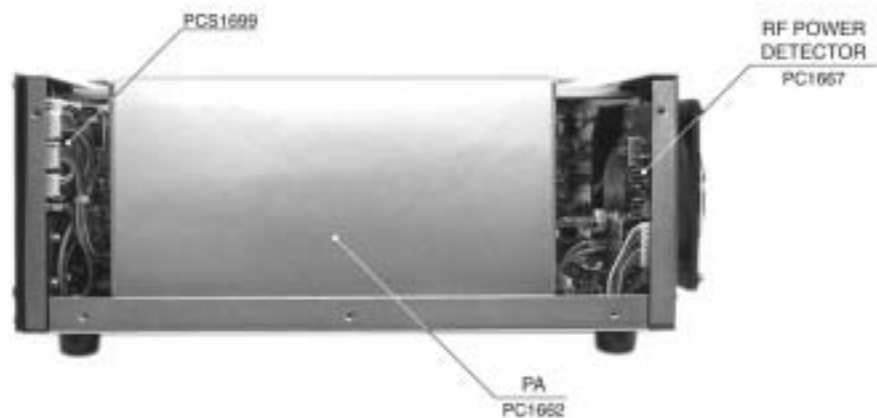
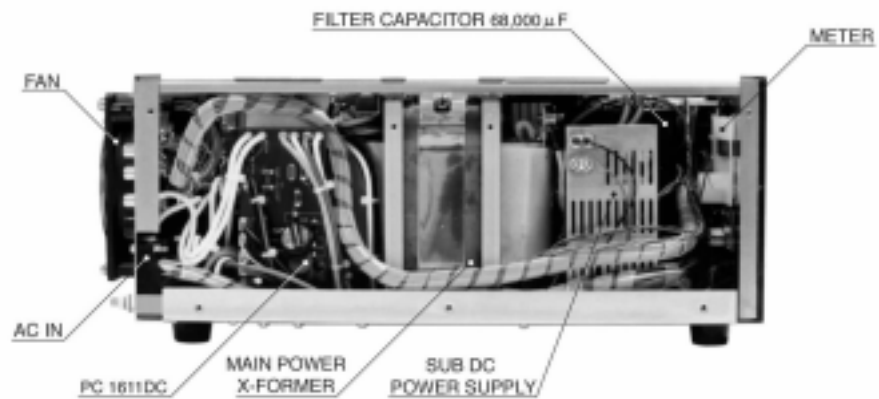
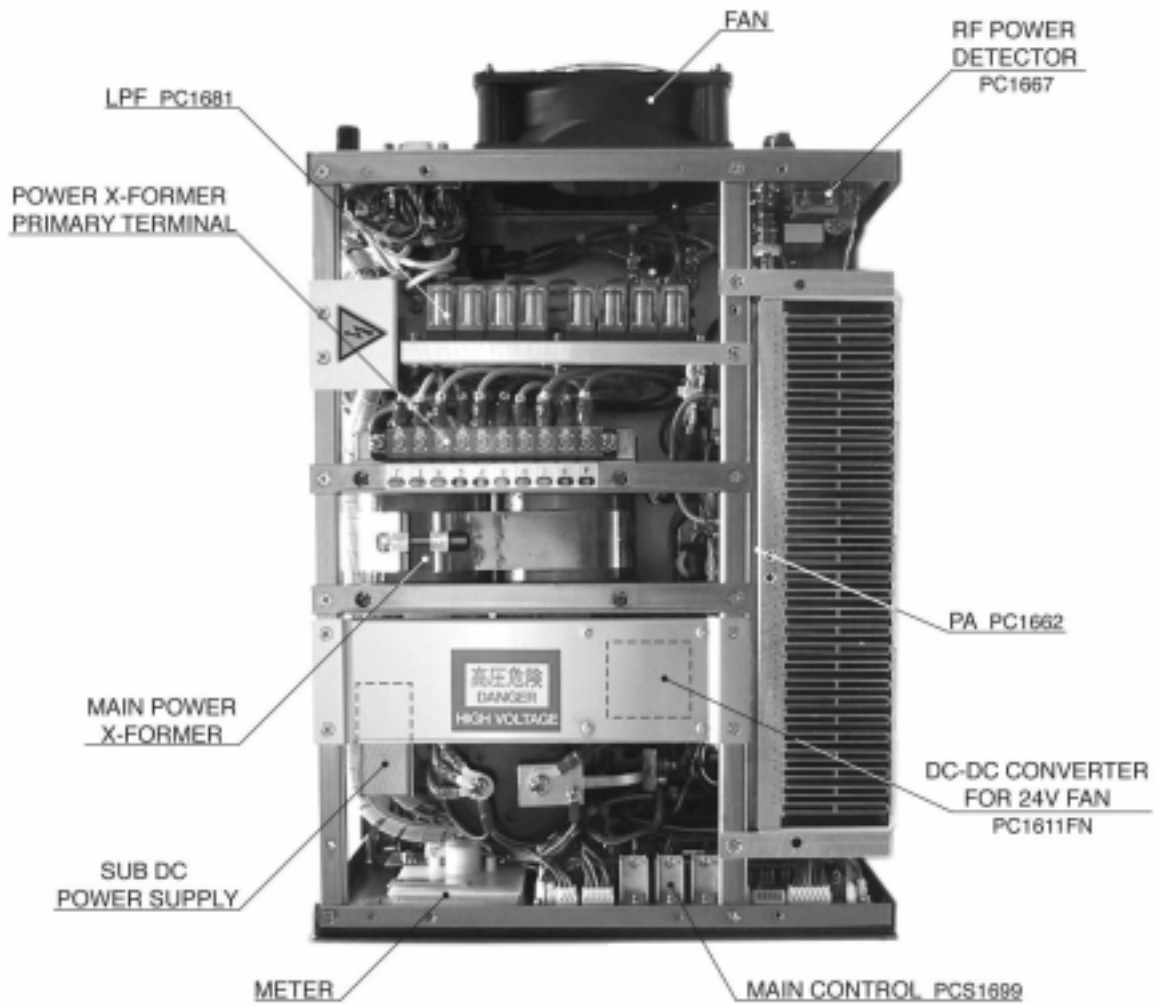

MAIN CONTROL (FRONT VIEW) : PCS1699

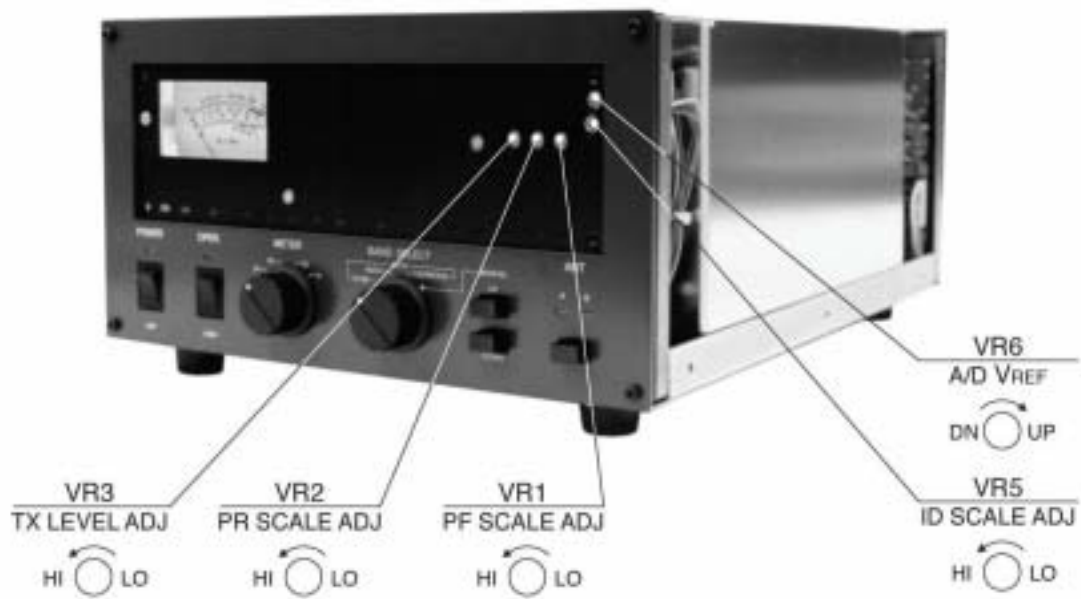

MAIN CONTROL : PCS1699 (TOP VIEW)

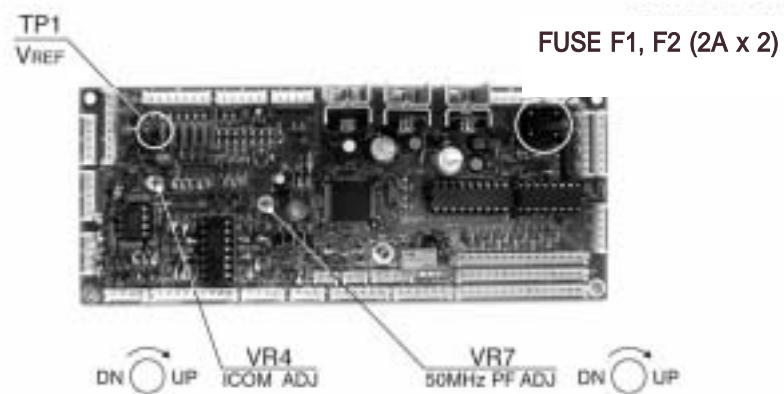

MAIN CONTROL : PCS1699 (BOTTOM VIEW)

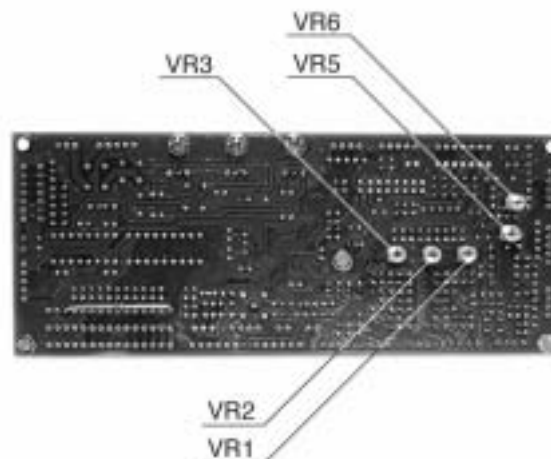

POTENTIOMETERS ON BOTTOM SIDE PCS1699 TO BE MADE ACCESS FROM FRONT SUB PANEL.

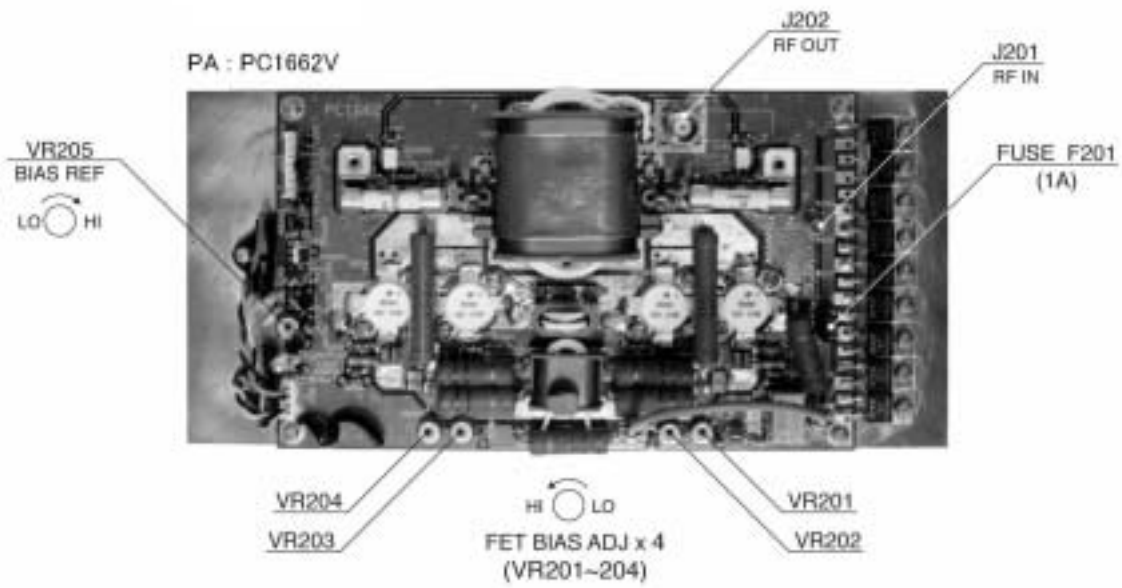

LPF : PC16B1 (TOP VIEW)

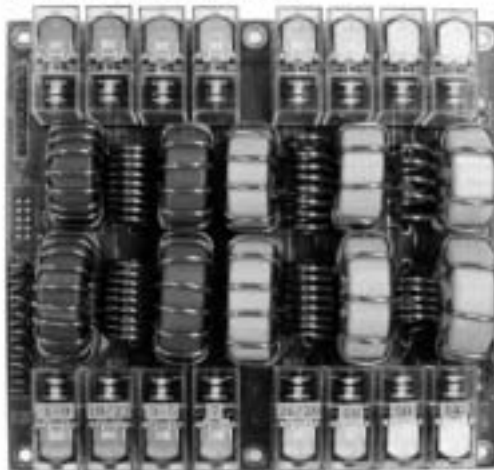

LPF : PC16B1 (BOTTOM VIEW)

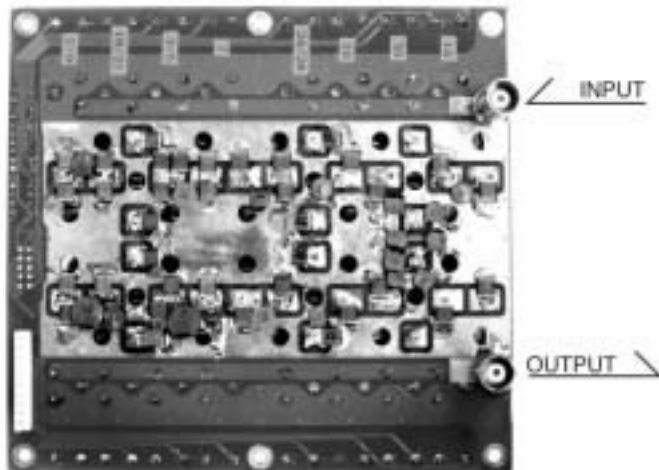

RF POWER DETECTOR : PC1667

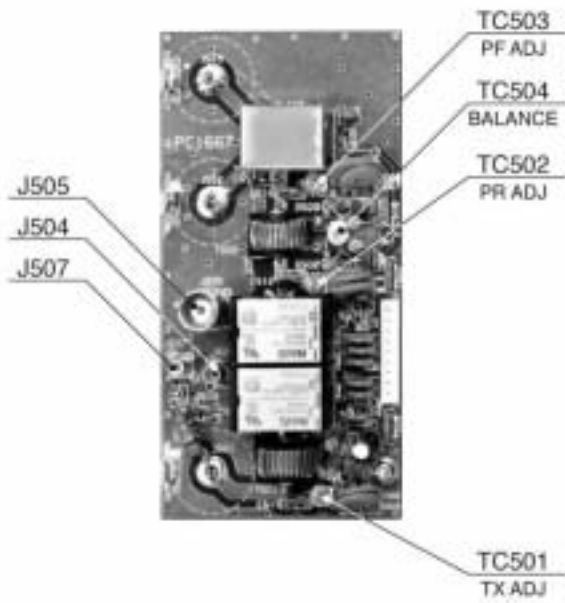

PRESCALER : PC1675



DC-DC CONVERTER FOR 24V DC : PC1611FN

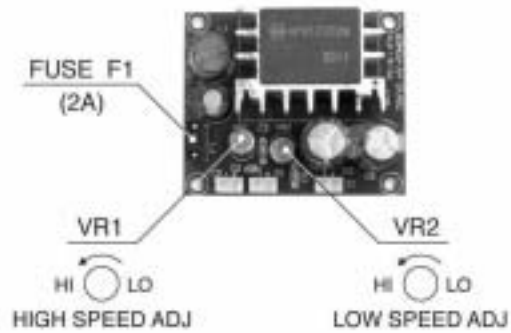

SURGE ABSORBER UNIT : PCS1750



HL-1.5KFX REAR PANEL CONNECTOR CONNECTIONS

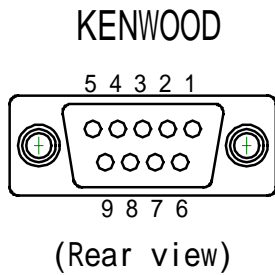

KENWOOD

PCS1699 J12

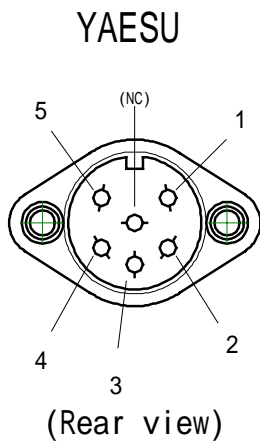
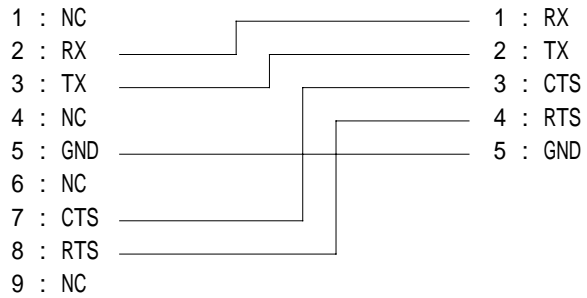

YAESU

PCS1699 J19

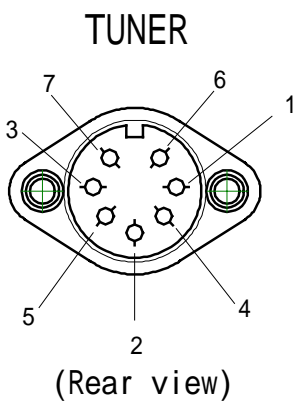
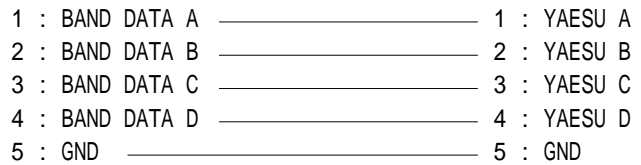

TUNER

PCS1699 J28

