



308 Industrial Park Road, Starkville, MS 39759 USA  
Ph: (662) 323-9538 FAX: (662) 323-6551

LJ-103BA  
Long John MonoBander  
3-Element, 10-Meter Beam

# INSTRUCTION MANUAL

## GENERAL DESCRIPTION

This model is a 3-element beam tuned for maximum forward gain over the entire 10-meter band. Both the antenna and the "beta match" are factory pretuned for maximum performance. The elements are made of taper-swaged tubing. The bracket will fit a 2" diameter mast. The electrical hardware is made from super strength stainless steel and all element tubing clamps are stainless steel.

The antenna requires a coaxial choke (or balun) to prevent unbalanced current from flowing down the transmission line and affecting the efficiency and match of the antenna.

FOR OUR OVERSEAS CUSTOMERS: The United States uses U.S. units of measurements. Please see the Metric Conversion Chart for assistance in identifying the hardware and components supplied with this product.

## VSWR AND FEEDLINE

This 10-meter beam is designed for use with a 50-ohm coaxial cable. A RG-213/u coaxial cable is recommended for lower losses and higher power handling capabilities.

## SPECIFICATIONS

### Mechanical

Boom length.....	8' (2.43 m)
Boom diameter.....	1 1/4" (3.2 cm)
Longest element (maximum).....	18'7" (5.58 m)
Turning radius.....	10'2" (3.05 m)
Maximum wind survival (no ice).....	Elements: 107 mph Boom: 174 mph
Weight (approx.).....	15 lbs. (6.8 kg)
Material.....	taper-swaged, aluminum tubing
Wind surface area.....	2 sq. ft. (0.186 sq. m)
Wind load at 80 mph.....	51.2 lbs. (23.22 kg)
Mast diameter.....	1 5/8"-2" (4.13 cm - 5.08 cm)
Element tubing clamps.....	all stainless steel, except for U-bolts
Suitable rotors.....	Telex/Hy-Gain CD45 and AR-40

### Electrical

Input impedance.....	50 ohms
*Power Gain.....	7.5 dBi (5.3 dBd)
*Front-to-back ratio (all lobes).....	24 dB maximum
VSWR (at resonance) less than.....	1.25:1
Maximum power.....	maximum legal
Cable requirements.....	RG-213/u (such as Belden 8267)
Lightning Protection.....	DC ground

\*Gain, Front-to-Back ratio verified by MININEC 3 and YAGI OPTIMIZER computer codes along with radiation pattern measurements of full size antennas on Hy-Gain's test range.



## UNPACKING

Unpack the antenna and check the parts against the Parts List and the drawings. This will simplify the antenna assembly.

## WARNING

When installing your system, take extreme care to avoid any accidental contact with powerlines or overhead obstructions. Failure to exercise this care could result in serious or fatal injury.

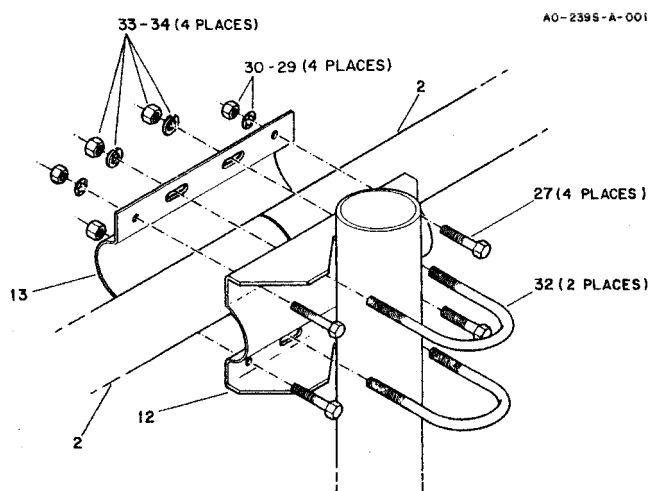

Item No.	Description
2	Boom, 1 1/4" x 48"
12	Boom-to-mast bracket
13	Clamp, boom-to-mast bracket
27	Bolt, 1/4"-20
29	Lockwasher, 1/4", internal
30	Nut, 1/4"-20, hex head
32	U-bolt, 5/16" x 2"
33	Lockwasher, 5/16", split
34	Nut, 5/16", -18

Figure 1  
Boom-to-mast bracket

## BOOM-TO-MAST ASSEMBLY

Select the boom-to-mast bracket (Item 12) and clamp (Item 13) and install it on the boom (Item 2) as shown in Figure 1. Use only the four outside holes, the elongated inside holes will be used for the U-bolts.

## ELEMENT-TO-BOOM BRACKET

Select a set of small sized element-to-boom brackets (Item 9) and loosely assemble them on one end of the boom approximately 2 3/8" from the end of the boom to the center of the bracket. Refer to Figure 2 for an assembly detail of the bracket. Do not forget the 1/4" x 3/8" anchor bolt (Item 26) and its associated square nut (Item 31). This will be the reflector end of the boom.

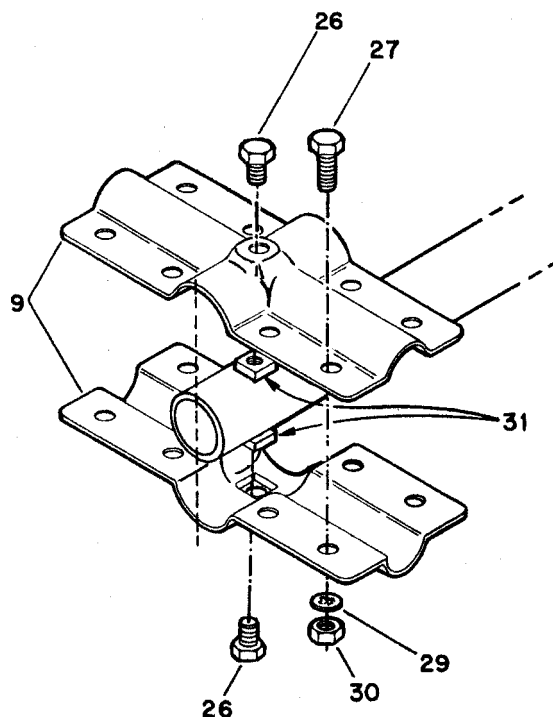

Item No.	Description
9	Bracket, #2, element-to-boom
26	Bolt, 1/4"-20 x 3/8", hex head
27	Bolt, 1/4"-20 x 3/4", hex head
29	Lockwasher, 1/4", internal
30	Nut, 1/4"-20, hex head
31	Nut, 1/4", square

Figure 2  
Element-to-Boom Bracket

## INSTALLATION OF TUBING CLAMPS

When installing the clamps, place the clamp near the tube end with the top of the clamp centered over the slot in the tube as shown in Figure 3.

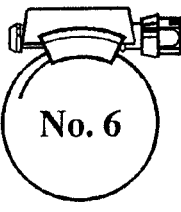
 <p><b>No. 6</b></p>	<b>Part No.</b>
	358756
	<b>Description</b>
	Clamp, Size #6, all Stainless Steel, 5/16" hex head screw.
	<b>Fits Tubing Sizes</b>
	1/2" and 3/4"

After adjustment of the tubing lengths, tighten the clamp with a 5/16 inch nut driver, socket, or open end wrench until the tubing will not twist or telescope.

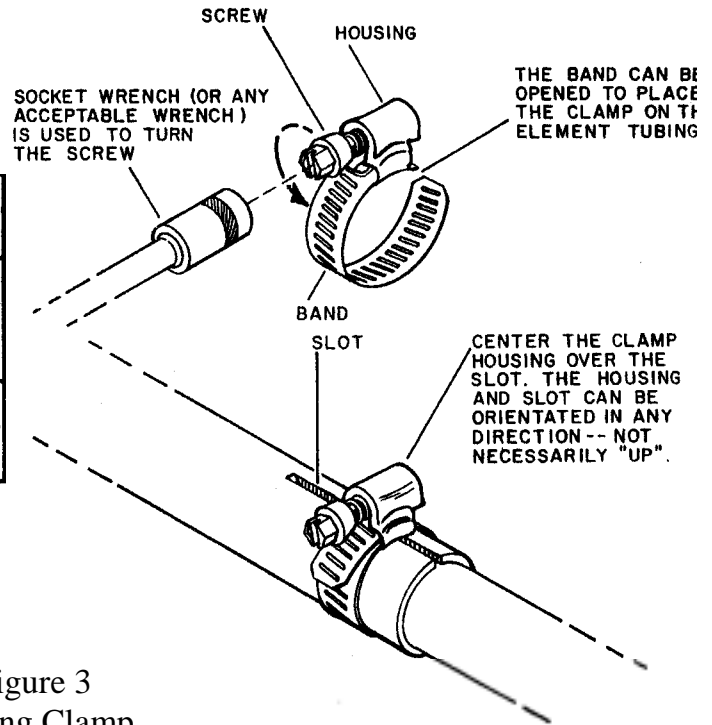

Figure 3  
Tubing Clamp

## RI ASSEMBLY

Select the RI section (Item 5), 7/8" x 44" and slip the unswaged end in the bracket assembled on the boom. Tighten the bolts enough to hold the element securely but do not *tighten* the anchor bolts at this time.

Adjust the bracket until it is 2 3/8" from the end of the boom to the center of the bracket and make certain the element will lie in a plane horizontal to the earth when the antenna is mounted on the mast. Now tighten the anchor bolts securely.

Select two #6 tubing clamps (Item 16) and slip them on the swaged ends of the RI sections. Position the clamps as shown in Figure 3. Do not *tighten* at this time.

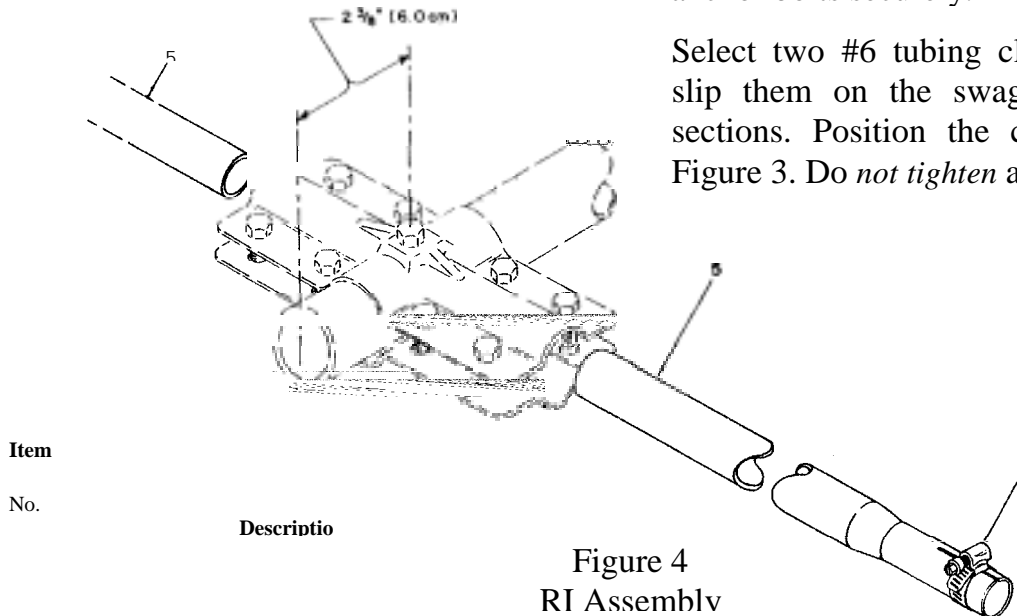

Figure 4  
RI Assembly

**R 2**

Select the R2 sections (Item 3), 5/8" x 24" and slip the unswaged ends into the R1 sections. Adjust the tubing to the dimensions shown in Figure 5. Now tighten the tubing clamps securely.

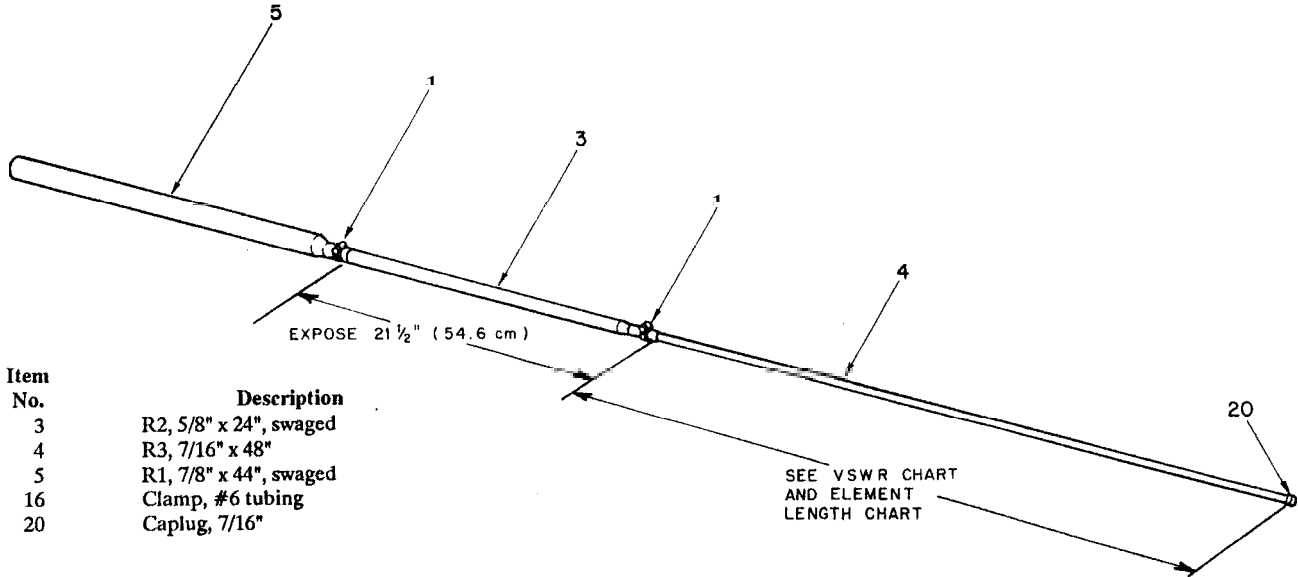

Figure 5  
Reflector Element

**R 3**

Select the R3 sections (Item 4), 7/16" x 48" and slip them into the R2 sections (Item 3). At this time you must decide which mode of transmission you will use. Four settings are given and typical VSWR curves shown should help you decide which mode will cover your frequencies.

These VSWR curves are typical for this antenna mounted 70 feet above ground, horizontally polarized. Similar curves can be expected for this antenna mounted at least 25 feet above ground. Do not try to tune this antenna for low VSWR at ground level!

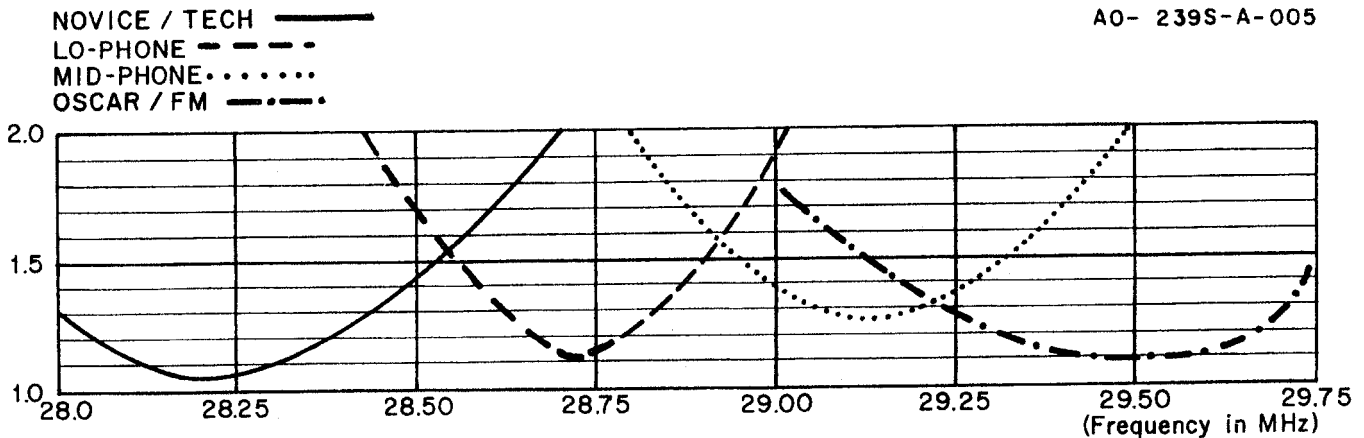

Figure 6  
VSWR Chart

A0- 239S-A-005

Adjust the R<sub>3</sub> sections (Item 4) to the dimension shown in Figure 8, then install a #6 tubing clamp (Item 16), and tighten securely.

### DRIVEN ELEMENT ASSEMBLY

Select the large size set of element-to-boom brackets (Item 8) and loosely assemble these brackets on the boom approximately 40 5/8" from the center of the reflector element bracket to the center of the driven element bracket. Select the DE1 sections (Item 1), 7/8" x 24" and the driven element insulators (Item 19). Slip the insulators over the unswaged ends of ED 1 then slip the insulated ends of ED1 into the bracket assembled on the boom. Tighten the bolts to hold the element securely but *do not tighten* the 1/4" x 3/8" anchor bolts (Item 26) at this time.

Select two #6 tubing clamps (Item 16) and slip them on the swaged end of the DE1 sections (Item 1). Position them as shown in Figure 3 from the end of the DE1 but *do not tighten at this time*.

Select the DE2 section (Item 6), 5/8" x 26", and slip them into the DE1 section. Measure the dimensions shown in Figure 8. Now tighten the tubing clamps securely.

Select the DE3 sections (Item 10) 7/16" x 58" and slip them into the DE2 sections (Item 6). Adjust to the dimension shown in Figure 8 for your mode of transmission then install a #6 tubing clamp (Item 16), and tighten securely.

Item No.	Description
1	DE1, 7/8" x 24", swaged
9	Bracket, #2, element-to-boom
19	DE Insulator
26	Bolt, 1/4"-20 x 3/8", hex head
27	Bolt, 1/4"-20 x 3/4", hex head
29	Lockwasher, 1/4", internal
30	Nut, 1/4"-20, hex head
31	Nut, 1/4", square

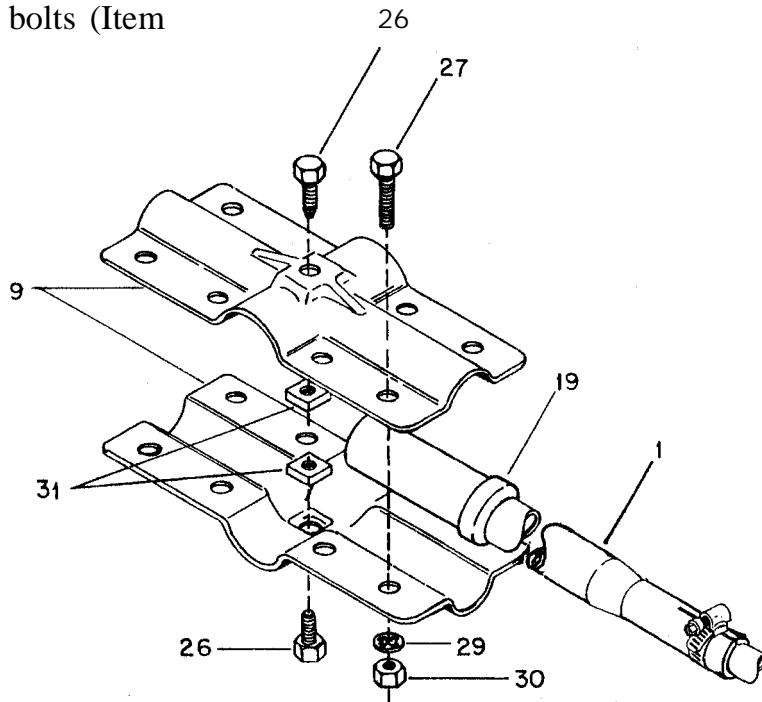
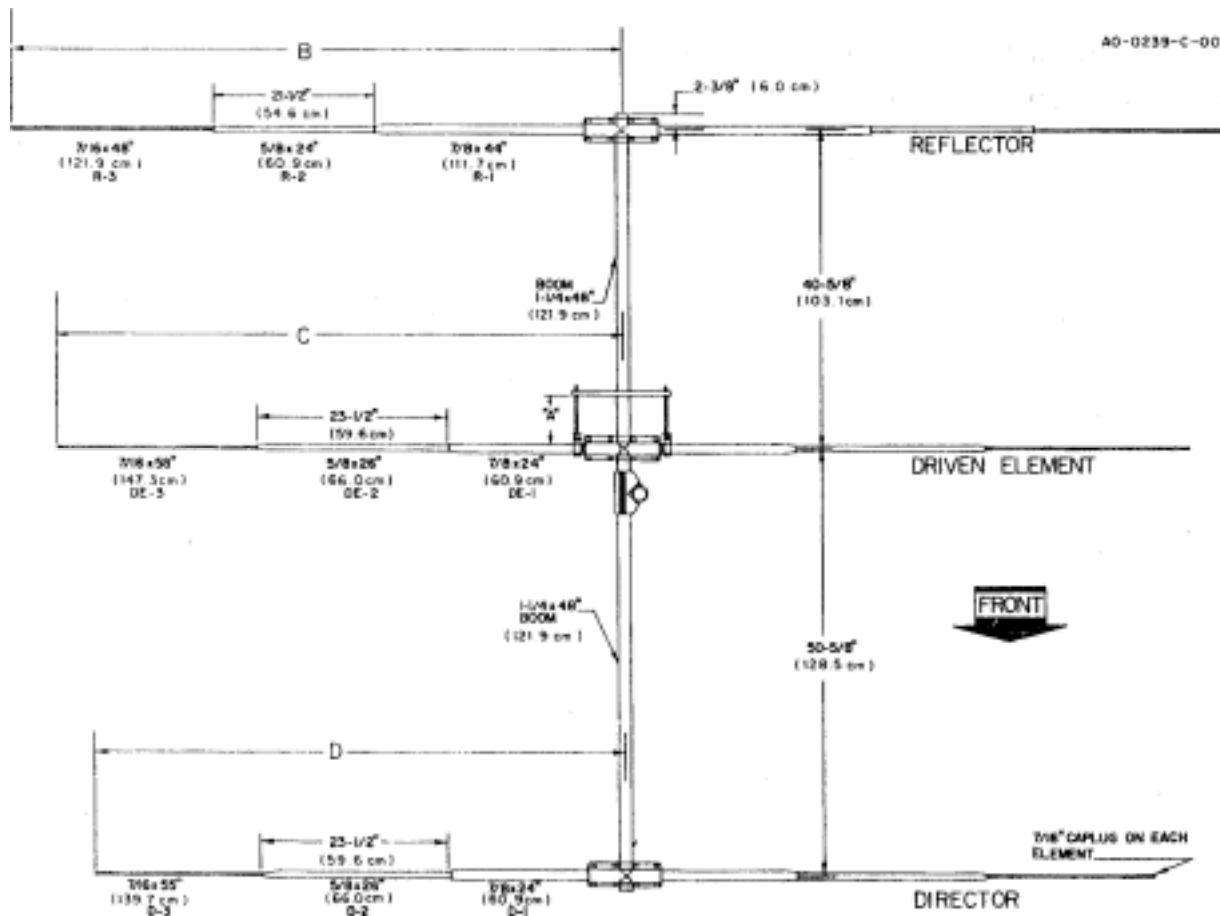

Figure 7

Driven Element Assembly

Carefully recheck the 40 5/8" measurement from the center of the reflector bracket to the center of the driven element bracket. Make certain the driven element bracket. Make certain the driven element will lie in the same plane as the reflector then tighten the anchor 1/4" x 3/8" anchor bolts securely.



	Novice/ Tech	Low Phone	Mid Phone	Oscar/ FM
REF (B)	111 1/2", (2.832 m)	109 3/4", (2.788 m)	107 1/2", (2.731 m)	105 1/2", (2.680 m)
DE (C)	103 7/8", (2.638 m)	101 1/2", (2.578 m)	99 7/8", (2.537 m)	99 3/8", (2.524 m)
DIR (D)	99 1/4", (2.521 m)	97 3/4", (2.483 m)	95 5/8", (2.429 m)	94 1/8", (2.391 m)

Element Length Chart (All dimensions measured from center of boom to tip of element)

Figure 8  
Overall View

**CAUTION**  
Be certain to use the same mode  
for dimensions on all elements.

**DIRECTOR ELEMENT**

Select the remaining element-to-boom brackets and loosely assemble them on the boom 50 5/8" from the center of the driven element bracket to the center of the director bracket.

Select the DI sections (Item 1), 7/8" x 24" and slip the unwaged ends into the bracket assembled on the boom. Tighten the bolts to hold the element securely but *do not tighten* the anchor screws at this time.

Carefully recheck the 50 5/8" measurement from the center of the driven element bracket to the center of the director bracket and check to see that the director will lie in the same plane as the previous elements. Now tighten the anchor bolts securely.

Select two #6 tubing clamps (Item 16) and slip them on the ends of the D1 sections. Position them as shown in Figure 3.

Select the D2 sections (Item 6), 5/8" x 26" and slip them into the D1 sections (Item 1). Adjust to the dimensions shown in Figure 8 for your mode of transmission then securely tighten the tubing clamps.

Select the D3 sections (Item 7) 7/16" x 55" and slip them into the D2 sections (Item 6). Adjust to the dimension shown in Figure 8 for your mode of transmission, then install and securely tighten the tubing clamps (Item 16).

### BETA MATCH

Select the beta rods (Item 11), the beta clamps (Item 15) and the 7/8" tubing clamps (Item 14). Assemble the beta match as shown in Figure 9. Adjust the beta match "A" dimension measured from the inside edge of the driven element to the inside edge of the beta clamp as shown in Figure 9. Tighten all screws securely.

Item No.	Description
11	Beta rod, 1/4"
14	Clamp, 7/8" tubing
15	Clamp, beta
21	Bolt, #10-24 x 1", hex head
22	Lockwasher, #10, internal
24	Nut, #10-24, hex

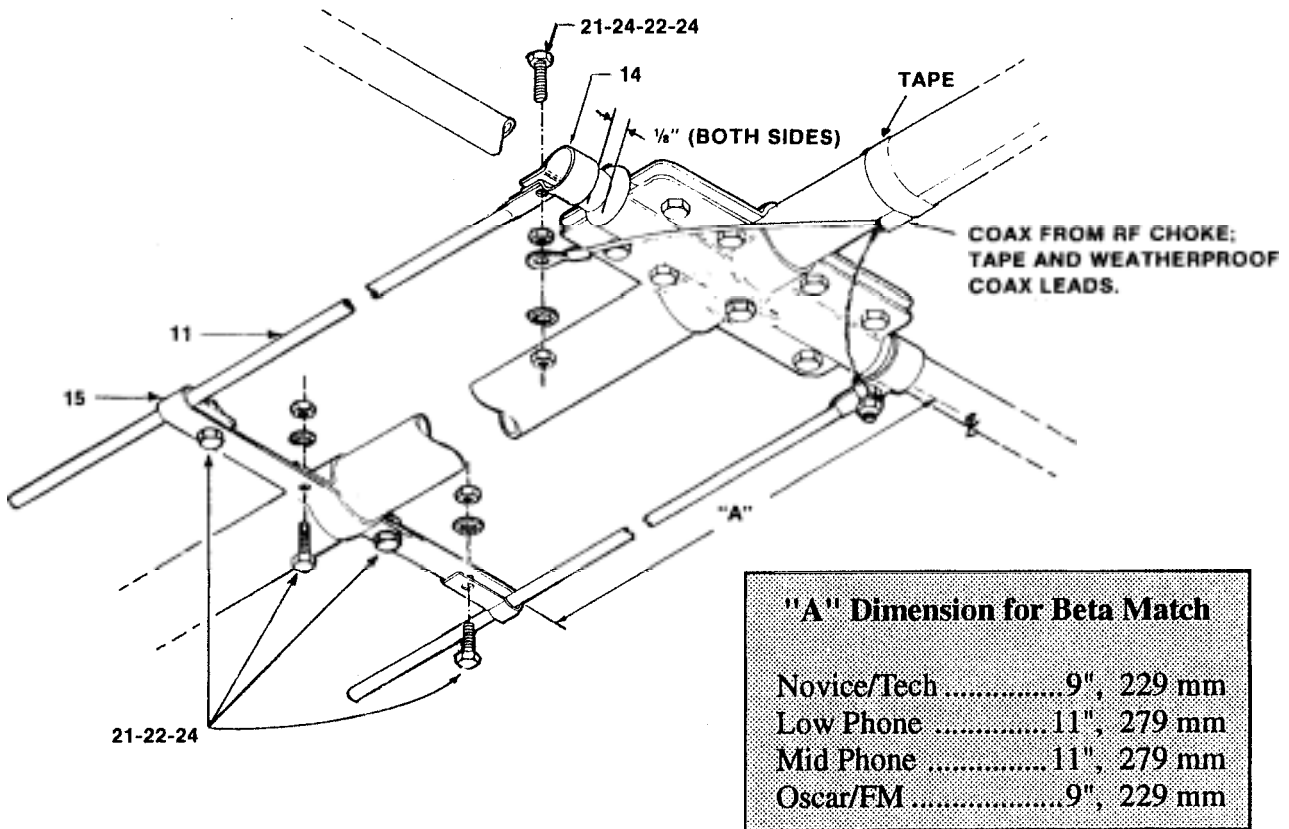

Figure 9  
Beta Match Assembly

## FINAL ASSEMBLY

A balun is not required for normal operation of this antenna. However, there are three recommended feedpoint configurations, one which utilizes the Hy-Gain Model BN-86 balun for increased performance and convenience.

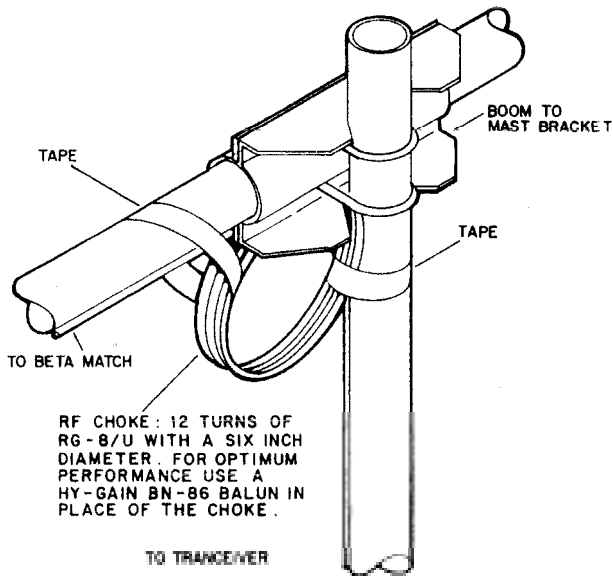

Figure 10  
RF Choke

The first feedpoint configuration involves connection of the coaxial feedline directly to the driven element. The recommended feedline is RG-213/U (such as Belden 8267). Other types of 50 ohm coaxial cable may be used if proper selection and careful assembly are utilized. The feedline should be stripped as shown in Figure 11. Attach solder lugs (not supplied) to the center conductor and shield for easy connection to the driven element.

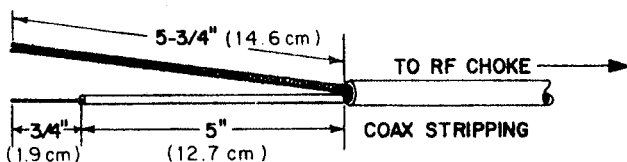

Figure 11  
Stripping Coax

The second feedpoint configuration involves construction and installation of a homemade RF choke. The RF choke will prevent RF from flowing on the outside of the coaxial shield. This will block radiation from the coaxial feedline, thereby reducing the risk of TVI and preventing radiation pattern degradation. Wind the RF choke from RG-213/U (or equivalent) coaxial cable. The choke should consist of 12 turns with an inside coil diameter of 6 inches: see Figure 10. Allow enough cable at the end to reach from the mast to the driven element. Strip the coaxial cable as shown in Figure 11. Attach solder lugs (not supplied) to the center conductor and shield for easy connection to the driven element.

The third feedpoint configuration involves using a 50 ohm 1:1 balun to connect the feedline to the driven element (Hy-Gain Models BN-86, or BN-4000 are recommended). A balun will act as an RF choke and will balance the flow of current on the driven element, resulting in a symmetrical radiation pattern. A balun will also have a coaxial connector, providing more convenience than a coax splice. Follow the instructions supplied with the balun for connection to the antenna.

NOTE: Use caution when selecting a balun to use with this antenna. Some baluns are designed for 50-75 ohm impedance and may result in a higher SWR when used with this antenna. For best results, use the Hy-Gain BN-86, 50 ohm balun. The Model BN-86 is available at your local Hy-Gain dealer. Hy-Gain Model BN-4000, rated at 2000 watts continuous, 4000 watts PEP is also available.

## ROPE DAMPENING INSTALLATION

Cut the rope into six equal lengths of 2 feet. Slip a length of rope into the end of each element. With about a 1/2" of rope extending from the element end, separate the fibers and fold them back over the element (Refer to Figure 12). Now slip a 7/16" caplug over the element and rope. The rope inside the element will prevent vibrations caused by wind.



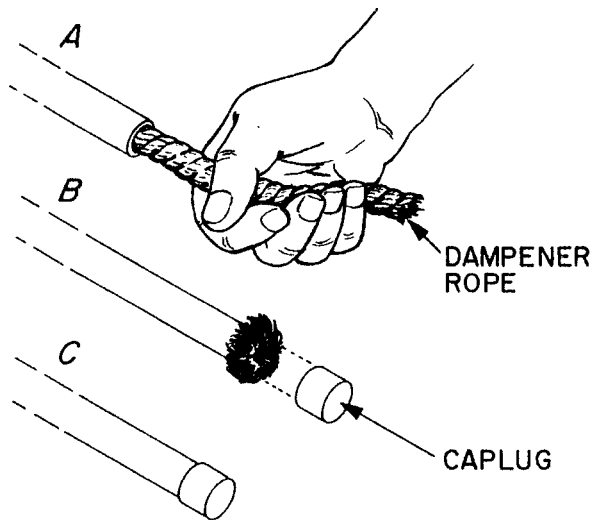

Figure 12  
Rope Dampening

**WEATHERPROOFING**

Weatherproof the coax connectors using Coax-Seal® or similar substance (not supplied).

Securely tape the RF choke and feedline to the antenna boom. Later when the antenna is mounted on the mast, the RF choke should also be taped to the mast.

Place a 1 1/4" caplug on each end of the boom.

Place a 7/16" caplug on the end of each element.

**INSTALLATION AND GROUNDING**

The antenna is now ready to be mounted on your mast.

A proper ground consist of a 1/2" x 8' copper-clad ground rod driven into the ground 12 inches from the base of the supporting structure.

Connect the ground rod to the supporting structure using a #8 or larger cooper wire and commercial non-corrosive ground clamps.

**WARNING**

When installing your system, take extreme care to avoid any accidental contact with powerlines or overhead obstructions. Failure to exercise this care could result in serious or fatal injury.

Coax-Seal® is a registered Trademark of Universal Electronic, Inc.

**PARTS LIST**

Item No.	Part No.	Description	Qty
1	190204	DE1 and D1, 7/8" x 24", swaged	4
2	174994	Boom, 1 1/4" x 48" ...	2
3	190004	R2, 5/8" x 24", swaged	2
4	174865	R3, 7/16" x 48"	2
5	190205	R1, 7/8" x 44", swaged	2
6	190006	DE2 and D2, 5/8" x 26", swaged	4
7	174939	D3, 7/16" x 55"	2
8	165138	Bracket, #1 element-to-boom, 1 1/4" x 1/4"	2
9	165141	Bracket, #2, element-to-boom, 1 1/4" to 7/8"	4
10	171533	DE3, 7/16 x 58"	2
11	172266	Beta rod, 1/4"	2
12	385142-1	Boom-to-mast bracket	1
13	385144-1	Clamp, boom-to-mast	

## PARTS LIST (Continued)

Item No.	Part No.	Description	Qty
	871986-1	Parts Pack 239S-1, stainless steel.....	1
14	163312	Clamp, 7/8" tubing .....	2
15	166084	Clamp, beta .....	2
16	358756	Clamp, #6 tubing.....	12
17		(Not Used)	
18	455630	Caplug, 1 1/4" .....	2
19	463767	Insulator, driven element.....	2
20	475639	Caplug, 7/16" .....	6
21	504069	Bolt, #10-24 x 1", hex head .....	6
22	565697	Lockwasher, #10, internal .....	6
23		(Not Used)	
24	554071	Nut, #10-24, hex .....	8
25		(Not Used)	
26	500156	Bolt, 1/4"-20 x 3/8", hex head.....	6
27	505266	Bolt, 1/4"-20 x 3/4", hex head.....	28
28		(Not Used)	
29	562961	Lockwasher, 1/4", internal .....	28
30	554099	Nut, 1/4", hex.....	28
31	551367	Nut, 1/4", square .....	6
32	540067	U-bolt, 5/16" x 2" x 3 5/8" .....	2
33	564792	Lockwasher 5/16", split .....	4
34	555747	Nut, 5/16"-18, hex.....	4
35	691138	Rope, 5/32" polyethylene x 12 ft. ....	1

### CONVERTING U.S. MEASUREMENTS TO METRIC

Use the scale to identify lengths of bolts, diameters of tubes, etc. The U.S. inch (") and foot (') can be converted to centimeters in this way:

1 inch (1 ") = 2.54 cm

1 foot (1') = 30.38 cm

Example: 42" x 2.54 = 106.7 cm

Scanned by IV3AJZ

Downloaded by

Amateur Radio Directory



## **hy-gain**® LIMITED WARRANTY

**Hy-Gain** Warrants to the original owner of this product, if manufactured by **Hy-Gain** and purchased from an authorized dealer or directly from **Hy-Gain** to be free from defects in material and workmanship for a period of 12 months for rotator products and 24 months for antenna products from date of purchase provided the following terms of this warranty are satisfied.

1. The purchaser must retain the dated proof-of-purchase (bill of sale, canceled check, credit card or money order receipt, etc.) describing the product to establish the validity of the warranty claim and submit the original or machine reproduction of such proof of-purchase to **Hy-Gain** at the time of warranty service. **Hy-Gain** shall have the discretion to deny warranty without dated proof-of-purchase. Any evidence of alteration, erasure, or forgery shall be cause to void any and all warranty terms immediately.
2. **Hy-Gain** agrees to repair or replace at **Hy-Gain's** option without charge to the original owner any defective product under warranty, provided the product is returned postage prepaid to **Hy-Gain** with a personal check, cashiers check, or money order for \$8.00 covering postage and handling.
3. Under no circumstances is **Hy-Gain** liable for consequential damages to person or property by the use of any **Hy-Gain** products.
4. Out-of-warranty Service: **Hy-Gain** will repair any out-of-warranty product provided the unit is shipped prepaid. All repaired units will be shipped COD to the owner. Repair charges will be added to the COD fee unless other arrangements are made.
5. This warranty is given in lieu of any other warranty expressed or implied.
6. **Hy-Gain** reserves the right to make changes or improvements in design or manufacture without incurring any obligation to install such changes upon any of the products previously manufactured.
7. All **Hy-Gain** products to be serviced in-warranty or out-of-warranty should be addressed to **hy-gain, 308 Industrial Park Road, Mississippi 39759, USA** and must be accompanied by a letter describing the problem in detail along with a copy of your dated proof-of-purchase.
8. This warranty gives you specific rights, and you may also have other rights which vary from state to state.