



308 Industrial Park
 Starkville, MS 39759 USA
 Ph: (662) 323-9538 FAX: (662) 323-6551

Model LJ-105CA
5 Elements, 10 Meter Beam

INSTRUCTION MANUAL

General

The Hy-Gain Model 105CA is a computer-optimized 5 element, 10 meter beam. The 105 CA features 5 full sized elements on a 24 ft. boom, a Hy-Gain adjustable beta-match, rugged boom-to-mast bracket, new stainless steel hardware and clamps for all electrical and mechanical connections. The 105CA is ideal for stacking with other Hy-Gain CA-monobanders - the 155CA and the 205CA for unparalleled performance and durability.

WARNING:
Installation of this product near power lines is dangerous.
For your safety, follow the installation directions:

Specifications

Electrical

*Power Gain (maximum gain setting)	10.75 dBi (8.6 dBd)
*Front-to-Back Ratio (maximum F/B setting)	.36 dB maximum
*-3 dB Beamwidth	.56 degrees
VSWR (at resonance)	less than 1.5:1
Nominal Impedance	.50 ohms
Power Rating	maximum legal
Matching Method	.beta
2:1 Bandwidth (broadband setting)	.1700 KHz

Mechanical

Boom	.2" x 24' (5.08 cm x 7.31 m)
Turning Radius	Approx. 15' (4.57 m)
Longest Element	.18 '1 1/2" (5.638 m)
Surface Area	.3.9 sq. ft. (0.3627 sq. m)
Wind Load @ 80 mph	.100 lbs. (45.359 kg)
Maximum Wind Survival	.100 mph (160.93 kmph)
Mast Diameter Accepted	.2" to 2 1/2" (51 mm to 64 mm)
Element Clamps	.stainless steel
Electrical Hardware	.18-8 stainless steel
Suitable Rotators	.Hy-Gain CD-45II or Ham IV
Optimum Stacking Distances	.30' (gain), 26' (F/B)

*Gain, Front-to-Back Ratio, and beam widths verified by MININEC3 and Yagi Optimizer© computer codes along with radiation pattern measurements of full size antennas on Hy-Gain's antenna test rankle.

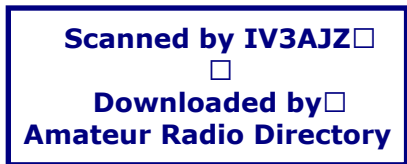

Electrical Design

The Hy-Gain Model 105CA 10 meter beam has been computer-optimized on seven standard settings. These are: CW, Low Phone, Mid Phone, OSCAR/FM, Broad-Band, Maximum FB, and Maximum Gain.

You may choose one of these settings or you may create your **own custom setting using** one of the standard settings and optimizing it within the YAGI OPTIMIZER® computer program.

The standard settings have the following characteristics:

Setting	Max. Gain (dBd)	Max. F/B (dB)	2.1 VSWR Bandwidth	Center Frequency
CW	8.20	27	1100 KHz	28.200
Low Phone	8.22	27	1100 KHz	28.400
Mid Phone	8.26	27	1100 KHz	28.800
OSCAR/FM	8.35	27	1100 KHz	29.500
Broad-Band	8.20	24	1700 KHz	28.800
Max F/B	7.56	36	600 KHz	28.500
Max Gain	8.60	23	400 KHz	28.500

Table 1

Item No.	Part No.	Description
1	102734	Bracket, cast aluminum
2	163371	Beta clamp
3	163764	Element-to-Boom bracket, #4
4	165919	Element-to-Boom bracket, #13
5	170418	Beta rod 1/4" x 35" (.64 x 89 cm)
6	171533	Tube, 7/16" x 58" (1.1 x 147 cm)
7	172732	Boom-to-Bracket clamp
10	174865	Tube, 7/16" x 48" (1.1 x 121.9 cm)
11	174939	Tube, 7/16" x 55" (1.1 x 139.7 cm)
13	190004	Tube, 5/8" x 24" (1.6 x 61 cm) swaged
14	190006	Tube, 5/8" x 26" (1.6 x 66 cm) swaged
15	190204	Tube, 7/8" x 24" (2.2 x 61 cm) swaged
16	190205	Tube, 7/8" x 44" (2.2 x 112 cm) swaged

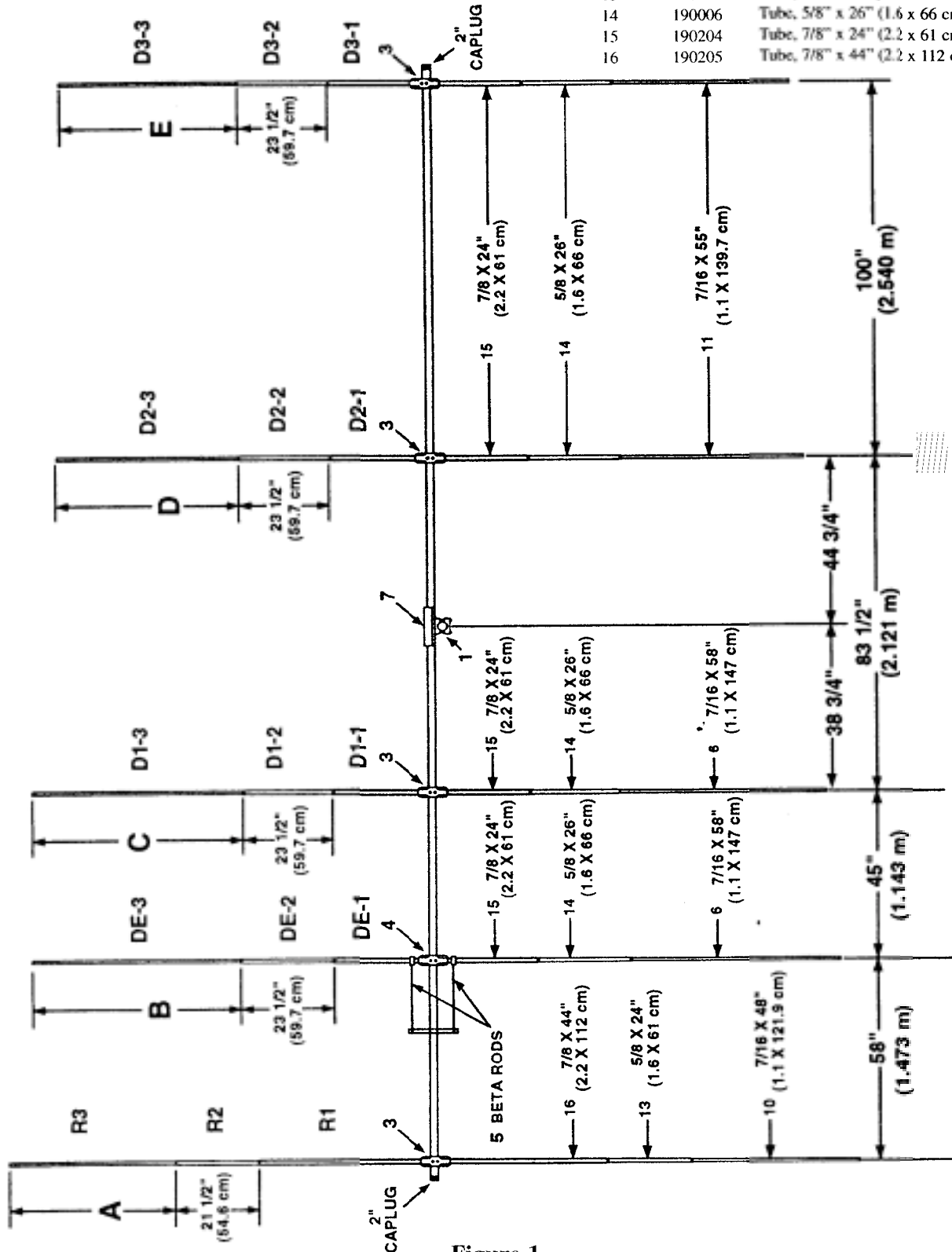

Figure 1
Overall View of Antenna with Dimensions

Element Tip

Setting	A	B	C	D	E	L (Beta Length)	Yagi Optimizer File Name
CW	42 1/4 (1073 mm)	54 3/8 (1381 mm)	53 1/2 (1359 mm)	51 3/4 (1314 mm)	48 (1219 mm)	17	HG105CA1.YAG
Low Phone	41 1/2 (1054 mm)	53 3/8 (1356 mm)	52 3/4 (1340 mm)	51 (1295 mm)	47 1/4 (1200 mm)	17	HG105CA2.YAG
Mid Phone	40 (1016 mm)	52 1/4 (1327 mm)	51 3/8 (1305 mm)	49 5/8 (1260 mm)	45 7/8 (1165 mm)	17	HG105CA3.YAG
OSCAR/FM	37 1/8 (943 mm)	49 1/2 (12_57 cnm)	48 5/8 (1235 mm)	46 7/8 (1191 mm)	43 1/4 (1099 Mill)	17	HG105CA4.YAG
Broad Band	42 (1067 mm)	51 1/2 (1308 mm)	49 (1245 mm)	48 (1219 mm)	43 1/2 (1105 mm)	28 3/8	HG 105CA5.YAG
Max FB	41 1/2 (1054 nun)	54 1/4 (1378 rnm)	52 1/2 (1334 mm)	45 7/8 (1165 mm)	38 1/4 (972 mm)	103/8	HG 105MAX.YAG
Max Gain	40 5/8 (1032 mm)	51 1/4 (1302 mm)	49 3/8 (1254 mm)	50 5/8 (1286 mm)	49 1/8 (1248 mm)	13 1/2	HG105MG.YAG

Table 2

Installation

All tubing supplied with the 105CA antenna is taper swaged and slotted, it is held in place with compression clamps. For optimum results from the antenna, make all measurements accurate using the dimensions given in Figure 1 and Table 2.

Boom Assembly

Select the cast aluminum brackets, boom-to-bracket clamp, and casting-to-boom bracket and loosely assemble as shown in Figure 2.

The bracket must be loose in order to finish the assembly of the boom.

Select the two center boom sections and slip the unswaged end of each into the boom-to-mast bracket. Align the holes in the boom with the holes in the bracket and secure as shown in Figure 2.

Install the outer boom sections as shown in Figure 3.

Item No.	Part No.	Description
1	102734	Bracket, cast aluminum
7	172732	Boom-to-Bracket clamp
8	172735	Casting-to-Boom bracket
9	173754	Boom, 2" x 75" drilled (5.1 x 190 cut)
12	175661	Inner boom, 2" x 75" swaged (5.1 x 190
21	455625	Caplug, 2"
29	505266	Bolt, 1/4"-20 x 3/4", hex head
31	505734	Bolt, 1/4"-20 x 2 1/2", hex head
32	562961	Lockwasher, 1/4", internal
33	554099	Nut, 1/4"-20, hex
3-5	506968	Bolt, 5/16"-18 x 2 3/4", hex head
36	500392	Bolt, 5/16"-18 x 3", hex head
37	500349	Bolt, 5/16"-13 x 5", hex head
39	564792	Lockwasher, 'V16", split
40	555747	Nut, 5/16"-1 S, hex
41	5142400	Bolt, 5/W'-t, x 3 3/4", hex head

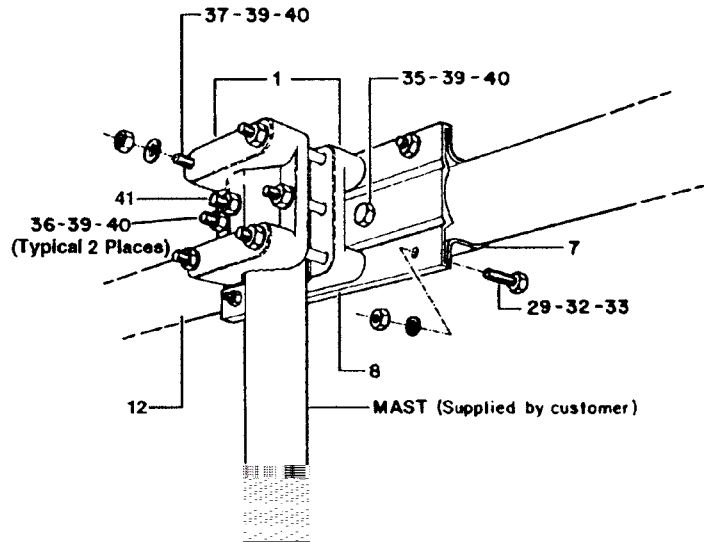

Figure 2
Boom-to-Mast Detail

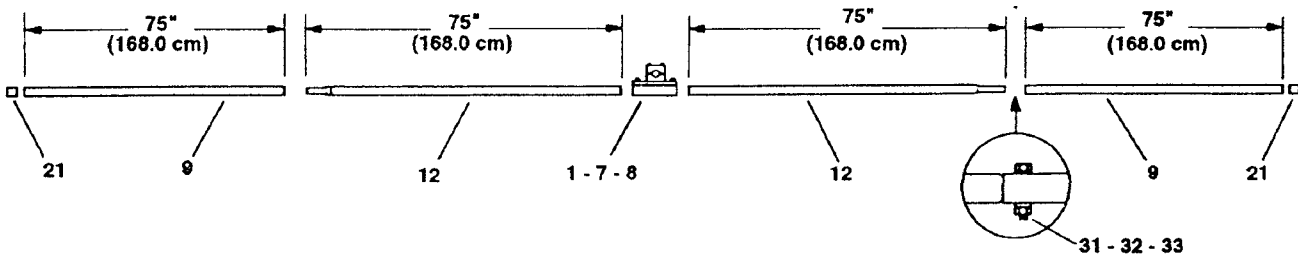

Figure 3 Boom Assembly and
Bracket Detail

Assembly of Element-to-Boom Brackets

Select the set of large element-to-boom brackets (item #4) and loosely assemble as shown in Figure 4.

Select the remaining four sets of element-to-boom brackets (Item #3) and loosely assemble as shown in Figure 4.

Slide each assembled bracket over a boom and position them as shown in Figure 1.

At this time you must decide which antenna setting you will use. See the Electrical Design paragraph and Table 1.

Item No.	Part No.	Description
3	163764	Element-to-Boom bracket, #4
4	165919	Element-to-Boom bracket, #1
28	5W 156	Bolt, 1/4"-20 x 3/8", hex head
29	505266	Bolt, 1/4"-20 x 3/4", hex head
32	562961	Lockwasher, 1/4", internal
33	554099	Nut, 1/4"-20, hex
34	551367	Nut, 1/4"-20, square

CAUTION

When you have selected your antenna setting, you must use the same setting for the remaining measurements. DO NOT try to use averages of various combinations of measurement settings on the same element or serious deterioration in the antenna performance will result. The VSWR and front-to-back charts shown in Figure 6-9 should help you decide which setting to select.

Assembly of Driven Element and Beta Match

NOTE: The following steps will have to be done first for one side of the boom then repeated for the other side.

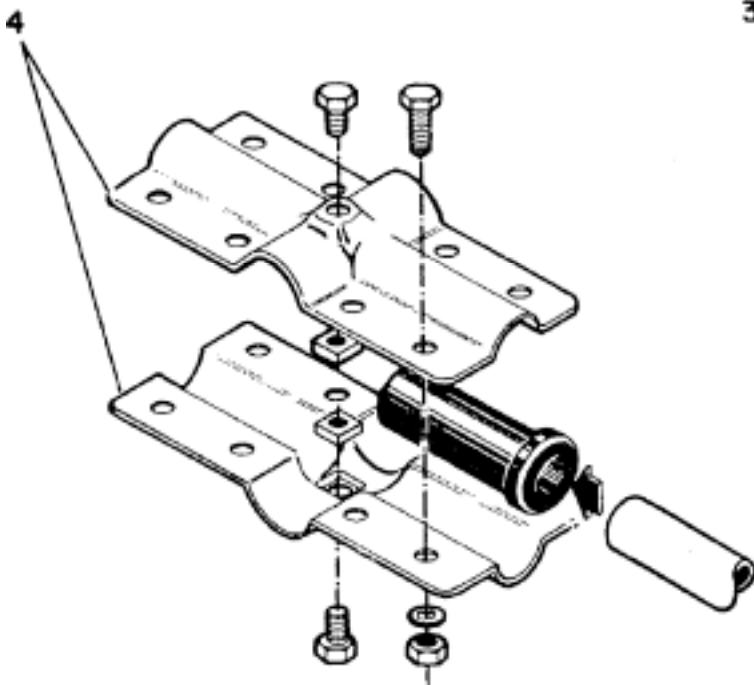

DRIVEN ELEMENT DETAIL

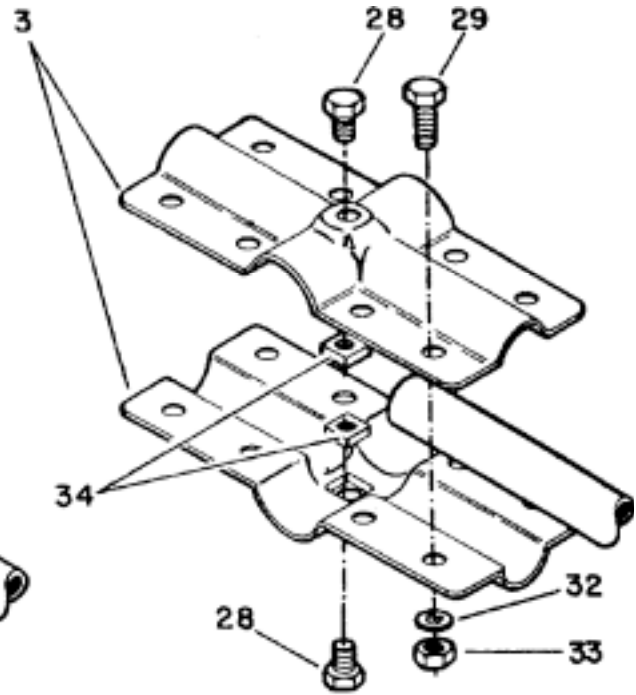

REFLECTOR-DIRECTOR DETAIL

Figure 4 Element-to-Boom Brackets

Select the DE 1 section of tubing. Slip the unswaged end of DE 1 into a driven element insulator as shown in Figure 4. Slip the insulated end of DE 1 into the bracket assembly on the boom. Tighten the screws to hold the element securely in the center of the bracket at this time.

Select the 1/4" Beta Rods. Attach the Beta Match to the boom as shown in Figure 5.

Loosely attach the opposite ends of the Beta rods to the tubing clamps on the driven element. Do Not tighten these screws at this time; the feedline will attach to this point in a later step. See Figure 5.

Check to see that the driven element will lie in a plane parallel to the earth, then tighten the anchor screws in the bracket securely.

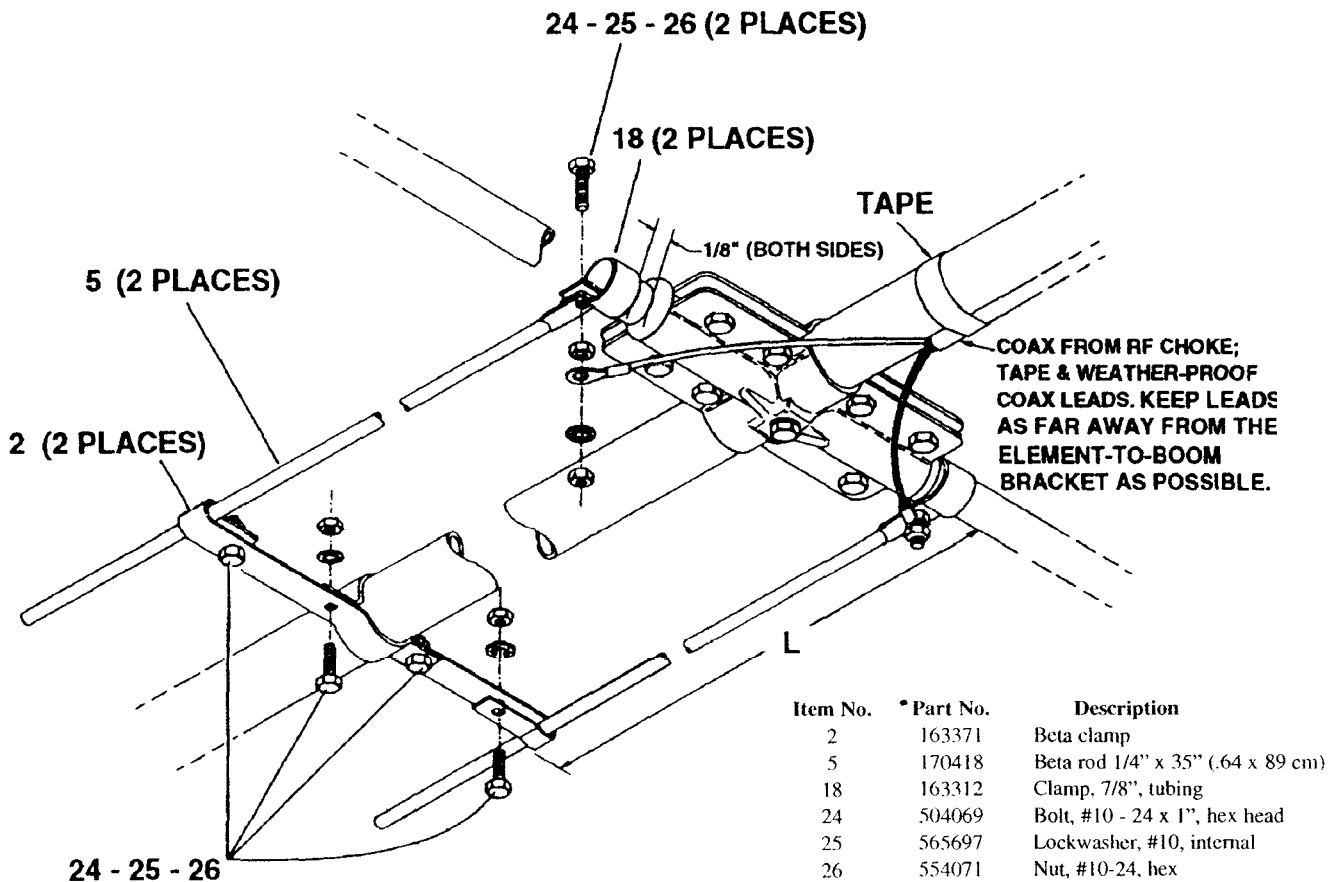
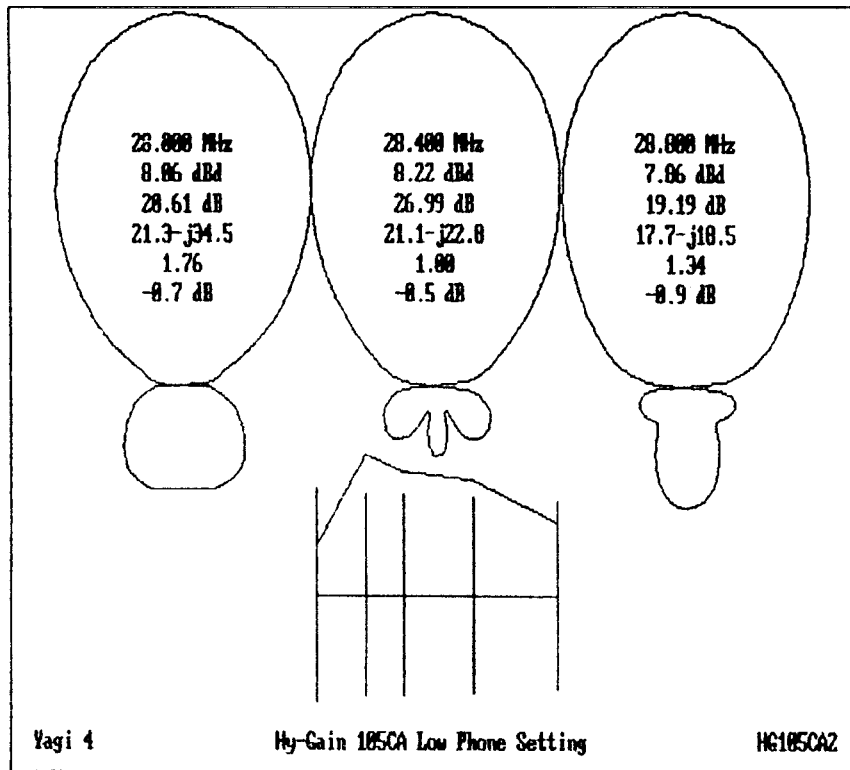

Figure 5 Beta Match Assembly

NOTE: Beta match dimension "L" is measured from the inside tubing edge to outside edge of clamp.

VSWR Charts

These VSWR curves are typical for this antenna mounted 70 feet above ground, horizontally polarized. Similar curves can be expected for this antenna mounted at least 25 feet above ground. Do Not try to tune this antenna for low VSWR at ground level! Refer to Figure 6-9.



Hy-Gain 105CA Low Phone Setting

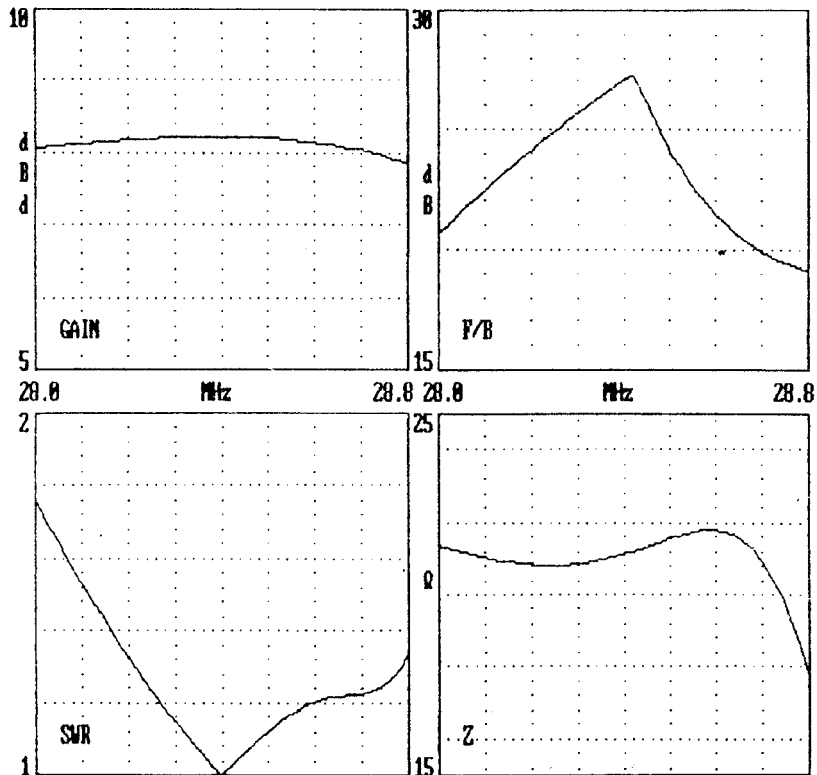
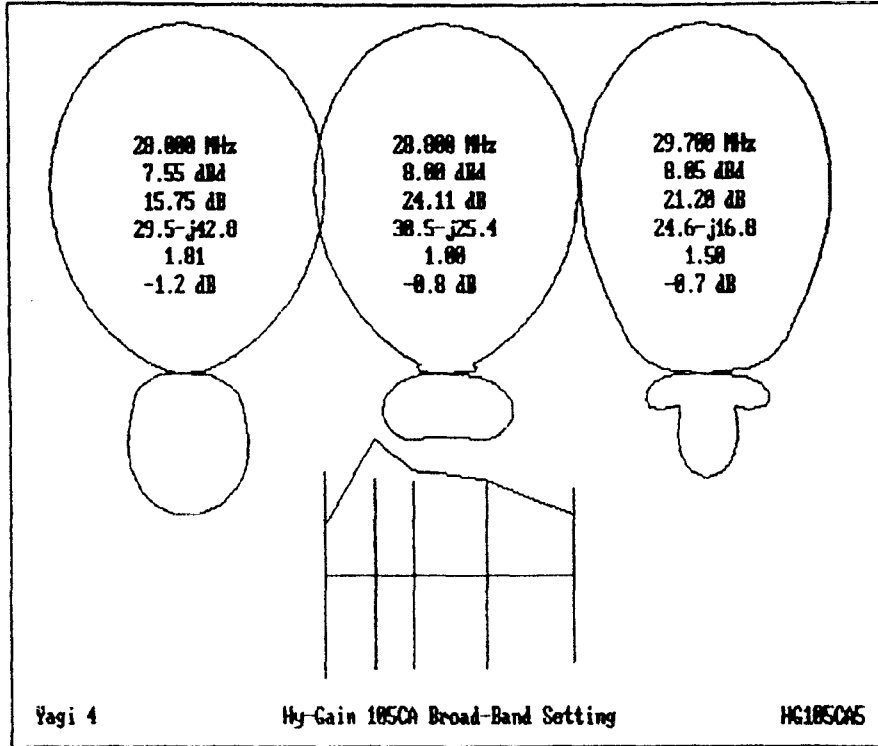

Figure 6 Hy-Gain 105CA Low Phone Setting



Hy-Gain 105CA Broad-Band Setting

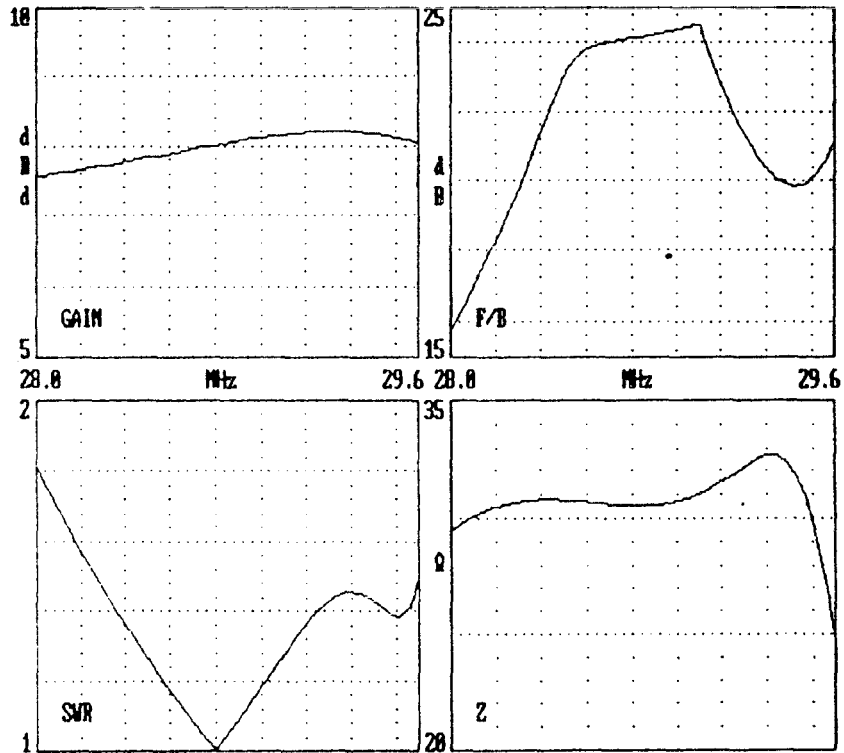
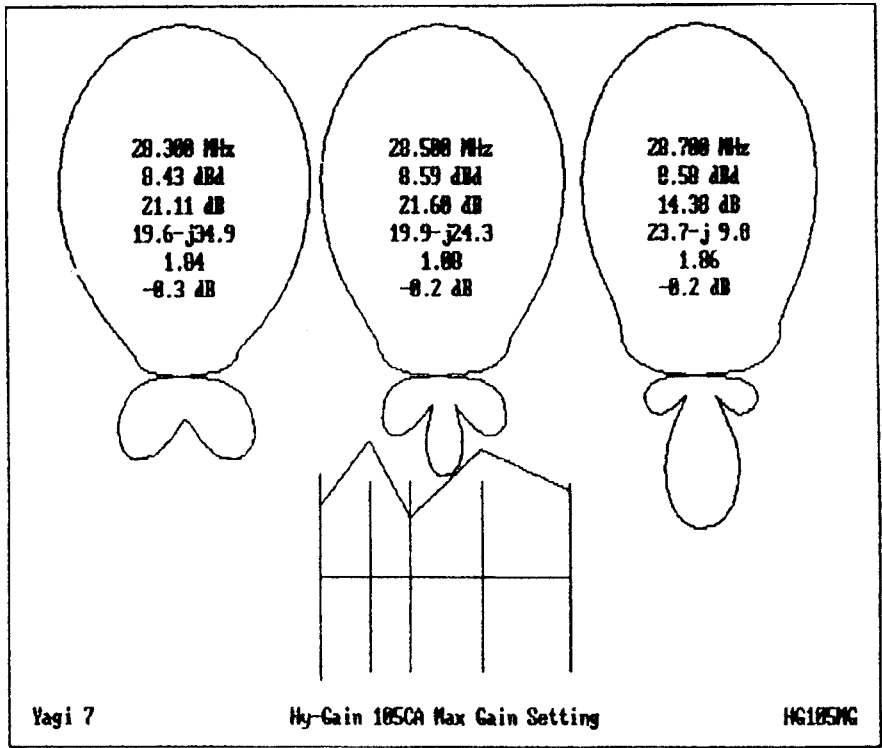

Figure 7 Hy-Gain 105CA Broad-Band Setting



Hy-Gain 105CA Max Gain Setting

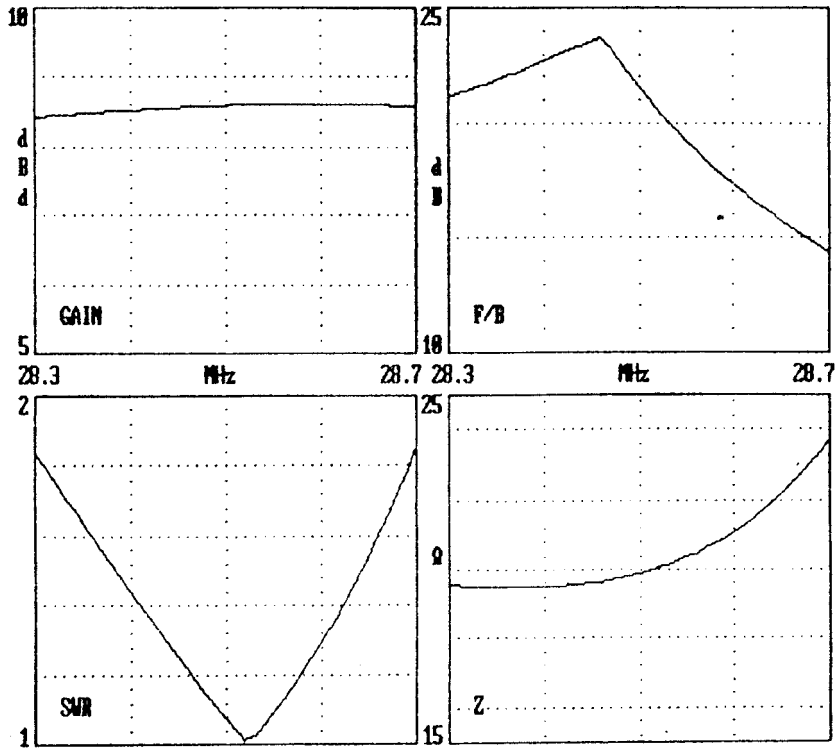
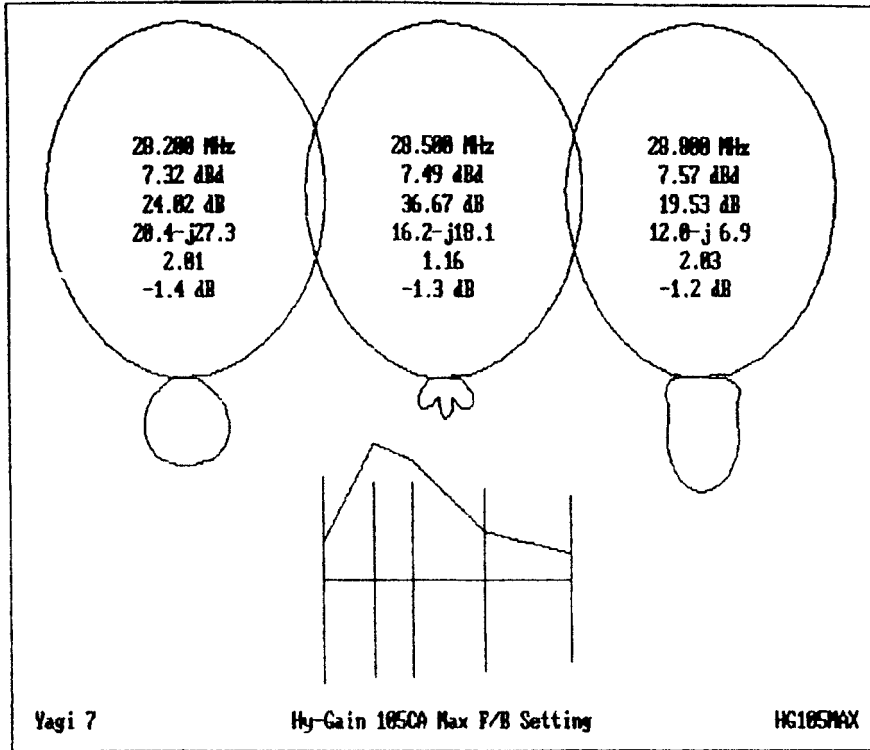

Figure 8 Hy-Gain 105CA Max Gain Setting



Hy-Gain 105CA Max F/B Setting

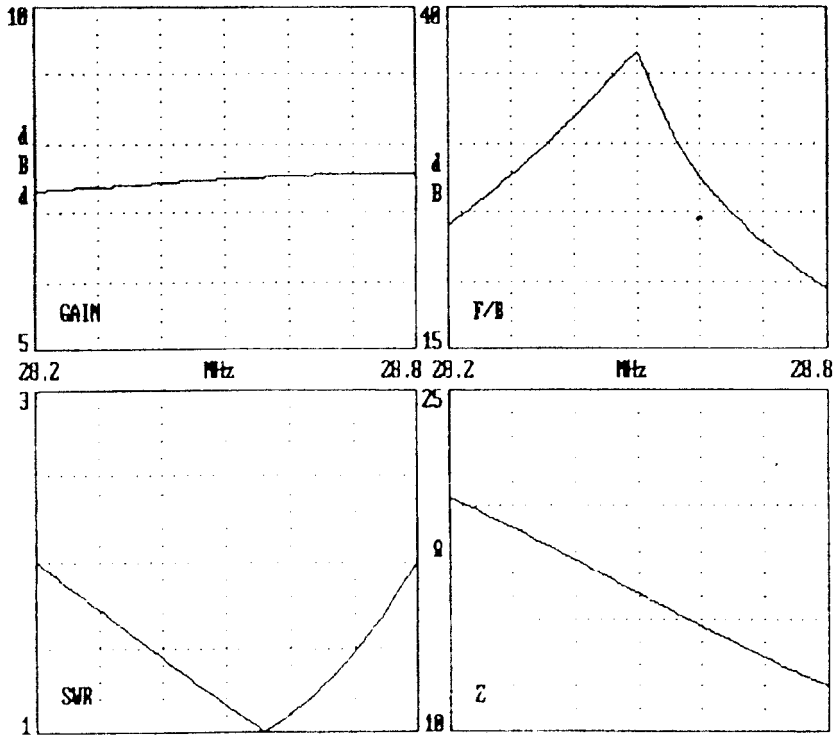

Figure 9 Hy-Gain 105CA Max F/B Setting

Installation of Tubing Clamps

Select the tube clamp as shown in the chart. When installing the clamps, place the clamp near the tube end with the top of the clamp over the slot in the tube as shown in Figure 10.

After adjustment of the tubing lengths, tighten the clamp with a 5/16 inch nut driver, socket, or open end wrench until the Whing will not twist or telescope.

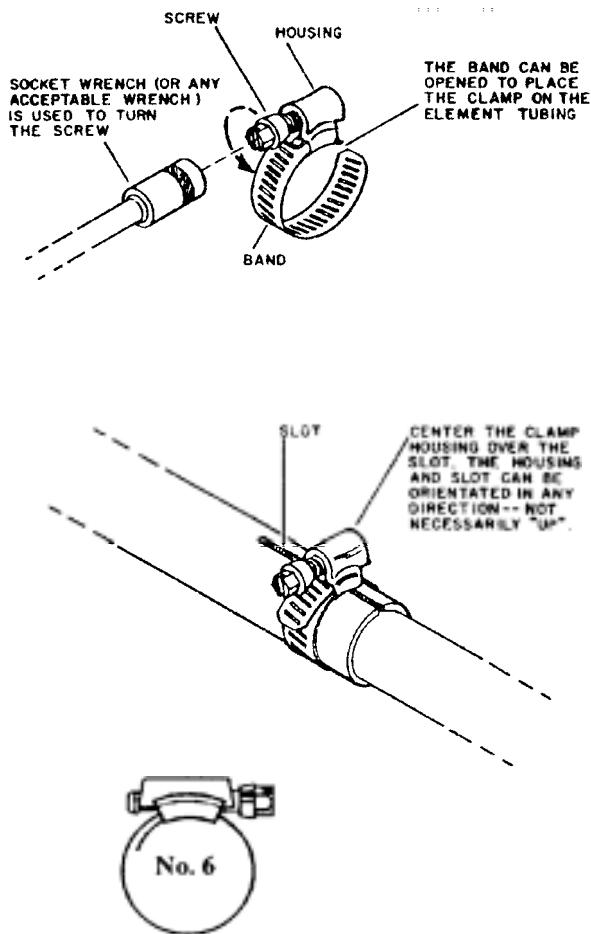

Figure 10 Tubing Clamp Detail

Part No.	Description	Fits Tubing Sizes
358756	Clamp, Size #6	7/16", 1/2"
	all stainless steel	5/8" and 3/4"

Slip a #6 tubing clamp over the end of the DE 1 section. Select the DE 2 section and slip the unswaged end into the DE 1 section. Adjust to the dimensions shown in Figure 1, then tighten the clamp securely.

Select DE 3 section and slip the end into the DE 2 section. Adjust the DE 3 section to the dimensions shown in Figure 1 and Table 2 for your mode of transmission. Now tighten the clamp securely.

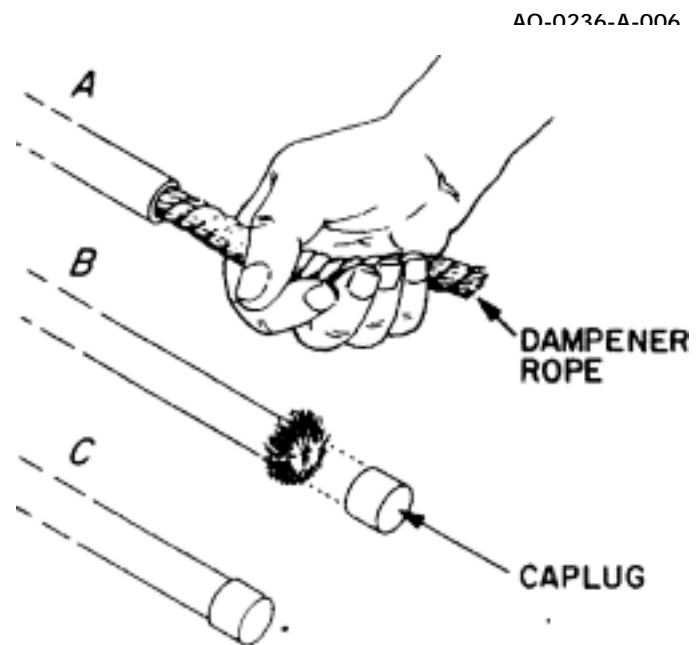

Figure 11 Rope Dampening

Rope Dampening

Select the rope and cut it into ten equal lengths of 6 feet. Slip a length of rope into the end of each element. With about a 1/2" of rope extending from the element end, separate the fibers and fold them back over the element (Refer to Figure 11). Now slip a 7/16" caplug over the element and rope. The rope inside the element will prevent vibrations caused by wind.

NOTE: To save time, loosely assemble all of the clamps and their appropriate hardware before beginning further installation of the antenna.

Assembly of the Reflector

Select the R1 section of tubing, and slip the unswaged end into the bracket assembled on the boom. Tighten the screws to hold the element securely, but do not tighten the anchor screws in the center of the bracket at this time.

Check to see that the reflector element will lie in the same plane as the given element. Carefully recheck the distance from the driven element, then tighten the anchor screws securely.

Assemble the remainder of the reflector element in the same manner as the driven element. Refer to Figure 1 and Table 2 for tubing descriptions and dimensions and to Figure 10 for tubing clamps.

Refer to Rope Dampening and Figure 11.

Assembly of Director 1

Select the D1-1 section of tubing, and slip the unswaged end into the bracket assembled on the boom. Tighten the screws to hold the element securely, but do not tighten the anchor screws at this time.

Check to see that the director will lie in the same plane as the other elements and carefully recheck the distance from the driven element. Tighten the anchor screws securely.

Assemble the remainder of the director element in the same manner as the previous elements. Refer to Figure 1 and Table 2 for tubing descriptions and dimensions and to Figure 10 for tubing clamps.

Refer to Rope Dampening and Figure 11.

Tighten all tubing clamps securely, be careful not to overtighten the tubing clamps.

Assembly of Directors Two and Three

Assemble the two remaining directors in the same manner as the previous elements. Refer to Figure 4 and 10.

Final Assembly

A balun is not required for normal operation of this antenna. However, there are three recommended feedpoint configurations, one of which utilizes the Hy-Gain Model BN-86 balun for increased performance and convenience.

The first feedpoint configuration involves connection of the coaxial feedline directly to the driven element. The recommended feedline is RG-213/u (such as Belden 8267). Other types of coaxial cable may be used if proper selection and careful assembly are utilized. The feedline should be stripped as shown in Figure 12. Attach solder lugs (not supplied) to the center conductor and shield for easy connection to the driven element.

The second feedpoint configuration involves construction and installation of a homemade RF choke. The RF choke will prevent RF from flowing on the outside of the coaxial shield. This will block radiation from the coaxial feedline, thereby reducing the risk of TVI and preventing radiation pattern degradation. Wind the RF choke from RG-213/u (or equivalent) coaxial cable'. The choke should consist of 12 turns with an inside coil diameter of 6 inches. Allow enough cable at the end to reach from the mast to the driven element. Strip the coaxial cable as shown in Figure 12. Attach solder lugs (not supplied) to the center conductor and shield for easy connection to the driven element. Tape the choke to the boom as close as possible to the D.E.

The third feedpoint configuration involves using a 50 ohm 1:1 balun to connect the feedline to the driven element. (Hy-Gain Models BN-86 or high-power BN-4000 are recommended). A balun will act as an RF choke and will balance the flow of current on the driven element, resulting in a symmetrical radiation pattern.

A balun also has a coaxial connector, providing more convenience than a coax splice. Follow the instructions supplied with the balun for connection to the antenna.

NOTE: Use caution when selecting a balun to use with this antenna. Some baluns are designed for 50-75 ohm impedance and may result in a higher SWR when used with this antenna. For best results, use the Hy-Gain BN-4000 or BN-86, 50 ohm baluns. Both models are available at your local Hy-Gain dealer.

Installing the Antenna

There are two recommended methods for getting the antenna to the top of the tower.

"WARNING: Installation of this product near power lines is dangerous. For your safety, follow the installation directions."

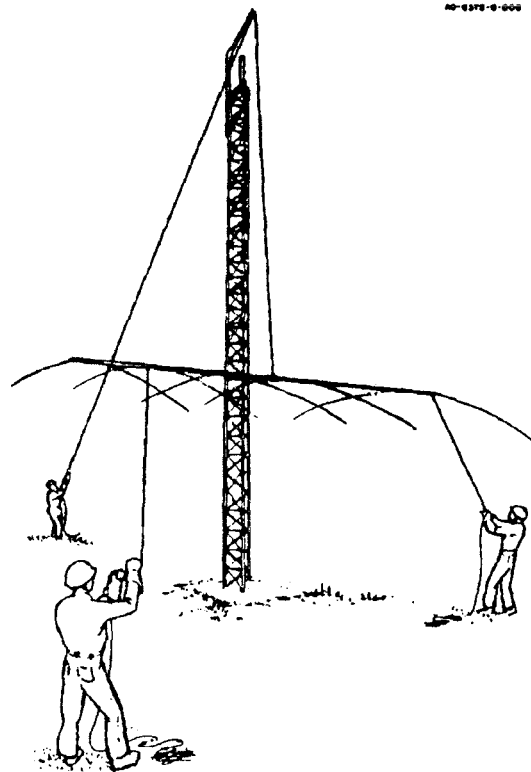

Figure 13
Raising Entire Antenna to Top of Mast

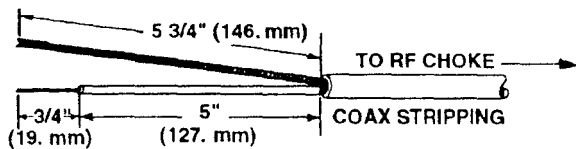

Figure 12 Coax Stripping Dimensions

Method One - Completely assemble the antenna on the ground, then hoist it into position using the set-up shown in Figure 13.

Method Two - Assemble the antenna on the ground in halves, then hoist each half up the tower and assemble on the boom-to-mast bracket on the tower as shown in Figure 14.

Mount the antenna on your mast using one of the two methods given. Tighten all screws in the boom-to-mast bracket securely.

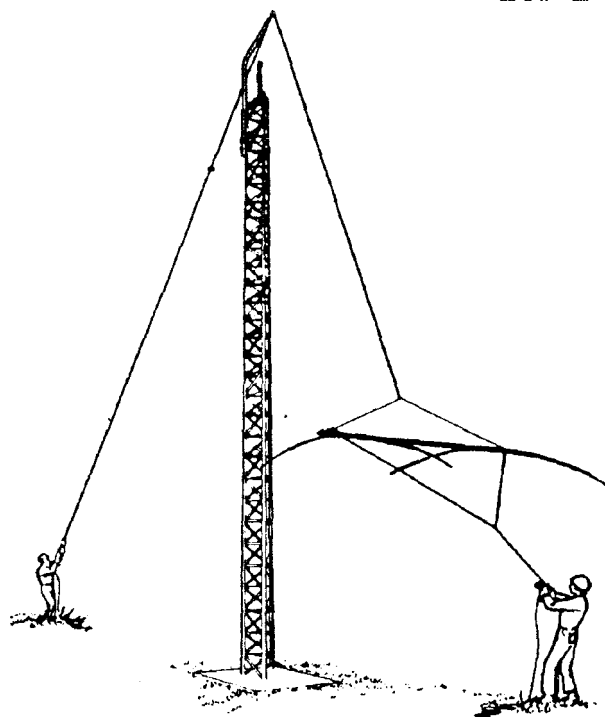

Figure 14 Raising Antenna in Sections to Top of Mast

NOTE: The boom-to-mast brackets have a hole through their centers to allow securing to the mast with the 5/16" - 18 x 3 1/2" bolt. It is recommended that the mast be removed and an 11/32" hole be drilled at the desired mast clamp position, then reinstall the mast. If this is not possible, the clamp will hold its position on the mast in all but the most severe weather conditions.

Securely tape the feedline to the mast, and your antenna is ready to use.

Weatherproofing

To prolong the life of this product in or around coastal areas it is recommended that all coaxial connectors be encapsulated with Coax-Seal @ or another similar substance. All electrical hardware is 18-8 stainless steel and requires no additional weather proofing.

Stacking the 205CA with the 155CA and 105CA

If you choose to stack the 205CA, 155CA and the 105CA in a christmas tree fashion, you must use a heavy mast. Recommended mast materials is 1027 cold drawn carbon steel tubing, 20 feet long, 2 inch O.D. minimum, 1/2" wall thickness minimum. 1027 cold drawn tubing has yield strength of approximately 70,000 p.s.i. If this is not available, you could also use 1018, 1020, 1025 or 1026 cold drawn tubing. These have yield strengths ranging from 55,000 to 65,000 p.s.i. Whatever you choose, you should check the yield strength specified by the manufacturer. If you cannot obtain high strength tubing, you should increase the O.D. or the wall thickness.

Recommended spacings for the 205CA, 155CA, and 105CA are listed below:

205CA - 6 inches above the tower
155CA - 9 feet above the 205CA
105CA - 7 feet above the 155CA

Using these spacings and the recommended mast with dimensions of 2" O.D. and 1/2" wall, you will have a moment of 3415 [ft-lbs. at](#) the top of the tower in an 80 mph wind and a flexural strength of approximately 55,684 p.s.i. Using 1027 cold drawn steel tubing, this will give you a safety factor of about 1.26:1

The spacings listed above will minimize the wind load on the mast and tower and minimize interactions between the antennas.

Lightning

You must ground your antenna supporting structure. This will also insure noise-free operation.

A proper ground consists of a 1/2" x 8' copper clad, steel ground rod driven into the ground 12 inches from the base of your tower or mast. Connect the rod to the tower or mast using #8 copper wire and commercial noncorrosive ground clamps.

Service

If you are unable to resolve technical problems, you should contact the Hy-Gain Customer Service Department in Starkville, MS.

You should retain your sales receipt or other proof of purchase for antennas that are still under warranty. (See separate sheet for Hy-Gain Warranty.)

All requests, inquiries or warranty claims, or to order replacement parts contact:

Hy-Gain
308 Industrial Park Road
Starkville, MS 39759 USA
Ph: (662) 323-9538
Fax: (662) 323-6551
<http://www.hy-gain.com>

Parts List

Item No.	Part No.	Description	Qty
1	102734	Bracket, cast aluminum	2
2	163371	Beta clamp	2
3	163764	Element-to-Boom bracket, #4	8
4	165919	Element-to-Boom bracket, #13	2
5	170418	Beta rod 1/4" x 35" (.64 x 89 cm)	2
6	171533	Tube, 7/16" x 58" (1.1 x 147 cm)	2
7	172732	Boom-to-Bracket clamp	1
8	17270-5	Casting-to-Boom bracket.....	1
9	173754	Boom, 2" x 75" drilled (5.1 x 190 cm)	2
10	174865	Tube, 7/16" x 48" (1.1 x 121.9 cm)	2
11	174939	Tube, 7/16" x _55" (1.1 x 139.7 cm)	6
12	175661	Inner boom, 2" x 75" swaged (5.1 x 190 cm)	2
13	190004	Tube, 5/8" x 24" (1.6 x 61 cm) swaged	2
14	190006	Tube, 5/8" x 26" (1.6 x 66 cm) swaged	8
15	190204	Tube, 7/8" x 24" (2.2 x 61 cm) swaged	8
16	190205	Tube, 7/8" x 44" (2.2 x 112 cm) swaged	2
17	690190	Rope, 5/32" x 60'. black	1
	871841	Parts Pack, Stainless Steel, 375	1
18	163312	Clamp, 7/8", tubing.....	2
19		(Not Used)	
20	358756	Clamp, #6, tubing	20
21	455625	Clamp, 2.....	2
22	455644	Caplug,7/16.....	10
23	463767	Insulator, 7/8" ID x 1 1/4" OD	2
24	504069	Bolt, #10 - 24 x 1 ", hex head	6
25	565697	Lockwasher, #10 internal	8
26	554071	Nut, #10-24,hex.....	6
27		(Not Used)	
28	560156	Bolt, 1/4"-20 x 3/8", hex head	10
29	505266	Bolt, 1/4"-20 x 3/4", hex head	45
30		(Not Used)	
31	505734	Bolt, 1/4"-20 x 2 1/2", hex head	2
32	562961	Lockwasher, 1/4", internal.....	59
33	554099	Nut, 1/4"-20, hex.....	51
34	551367	Nut, 1/4"-20, square	10
35	506968	Bolt, 5/16"-18 x 2 3/4, hex head	2
36	500392	Bolt, 5/16"-18 x 3", hex head, stainless steel.....	2
37	500349	Bolt, 5/16"-18 x 5", hex head, stainless steel.....	4
38	560024	Flatwasher, 5/16.....	7
39	564792	Lockwasher, 5/16", split	13
40	555747	Nut, 5/16"-18, hex.....	9
41	5142400	Bolt, _5/16"-18 x 3 3/4", hex head, stainless steel	1

Converting English Measurements to Metric

Use this scale to identify lengths of bolts, diameters of tubes, etc. The English inch (") and foot (') can be converted to centimeters in this way.

1 inch (1") = 2.54 cm 1 foot (1') = 30.48 cm

Example: 42" x 2.54 = 106.7 cm

