



Digital Voice Modem
ARD9000

Instruction Manual



AOR, LTD.

Authority On Radio communications

Thank you for purchasing the AOR **ARD9000** Digital Voice Modem.

All over the world, hams have been discovering how much fun it is to work HF without background noise.

AOR sets the pace in this breakthrough technology with its ARD9800. Now, in response to worldwide demand, AOR has developed the **ARD9000** which makes digital voice communications even more affordable.

AOR's digital voice technology delivers audio quality you have to hear to believe. Whether you are working digital voice across borders or across an ocean, amazing doesn't seem strong enough to describe it.

With an **ARD9000**, it's easy to convert existing HF analog transceivers to work digital voice with NO transceiver modifications. The **ARD9000** automatically detects a digital signal and decodes it, so you also maintain full analog capabilities. Whether a contact comes in as digital or analog, the **ARD9000** can handle it. Digital voice could be the biggest revolution in HF radio since SSB!

Please read through this instruction manual and familiarize yourself with the operation of the **ARD9000**. We suggest you to keep this instruction manual for future reference.

We believe you will enjoy using the **ARD9000** as an enhancement to your enjoyment of amateur radio.

AOR, LTD.

Features:

- **No transceiver modifications needed.**

The ARD9000 uses the same audio frequencies (300Hz~2500Hz) as microphone audio to modulate the voice signal. This allows you to use an analog radio as a digital voice radio.

- **Works on Single Side Band (SSB) mode.**

The Automatic frequency clarifier function adjusts frequency offsets automatically in the SSB mode. (Approximately up to +/- 125Hz). Utilizes the OFDM (Multi Carrier Modulation) circuit that is effective against Multi-path or Selective Fading.

- **Automatic digital receive**

Automatic voice signal detector recognizes the received signal as analog or digital, automatically switching to the appropriate mode.

- **Built-in high grade Vocoder (AMBE)**

Utilizing high-grade digital voice compression delivers quality digital voice communication.

- **Built-in FEC error correction**

A powerful error correction circuit delivers stable and reliable communication.

- **Small and compact unit. Easy to operate.**

Simply connect the ARD9000 between the microphone jack and microphone. No complicated modifications necessary. Optional interface cable for most popular transceivers are available or you can build your own connectors.

- **Wide range of operation voltages**

Operates on 10 to 16V DC from an external power source.

- **Utilizes a uniquely designed high performance DSP engine.**

- **Uses established G4GUO open protocol.**

ARD9000 vs. ARD9800

You might already know our ARD9800 Multi-Mode and Digital Voice Interface. The main differences between the ARD9000 and the ARD9800 is that the ARD9000 is a VOICE ONLY modem. However, both models are fully compatible for voice use.

Precautions

To prevent fire, personal injury, or unit damage, please observe the following precautions:

- Do not attempt to adjust this unit unless instructed to do so by this manual.
- Do not expose the unit to direct sunlight or place the unit close to heating appliances.
- Do not place the unit in excessively dusty, humid or wet areas.
- We are not responsible for any damages to the radio equipment due to improper settings or interface.
- We are not responsible for any loss of communications due to an unexpected change in propagation or the operating environment.

Table of Contents

	Page
Supplied & optional accessories	5
Wire connection	6
Magnetic mount	6
Controls and functions	7
Front panel	7
Speaker / microphone	7
Overload indicator	8
Mode rotary switch	8
Status LED	9
Synchronization push button	9
Power / volume knob	9
Rear panel	9
DC IN connector	9
Speaker OUT connector	10
Speaker IN connector	10
Radio connector	11
FG screw	11
Presetting	12
Microphone level	12
Output level to radio	12
Input level from radio	14
Operation / Voice communication	15
Factory default settings	15
Specifications	16

Supplied Accessories

The following items are provided in the package:

<u>Accessory</u>	<u>Quantity</u>
Speaker Microphone	1
Speaker Cable	1
DC Power cable	1
8 pin metal plug (for radio cable)	1
Instruction manual on CD	1
Magnetic mount base (CR25) with screw (M3)	1

Optional Accessories

Pre-wired microphone interface cable for most popular transceivers.

Wire connection

The graphic below describes the basic cable connections to allow you to operate the ARD9000 in its default configuration.

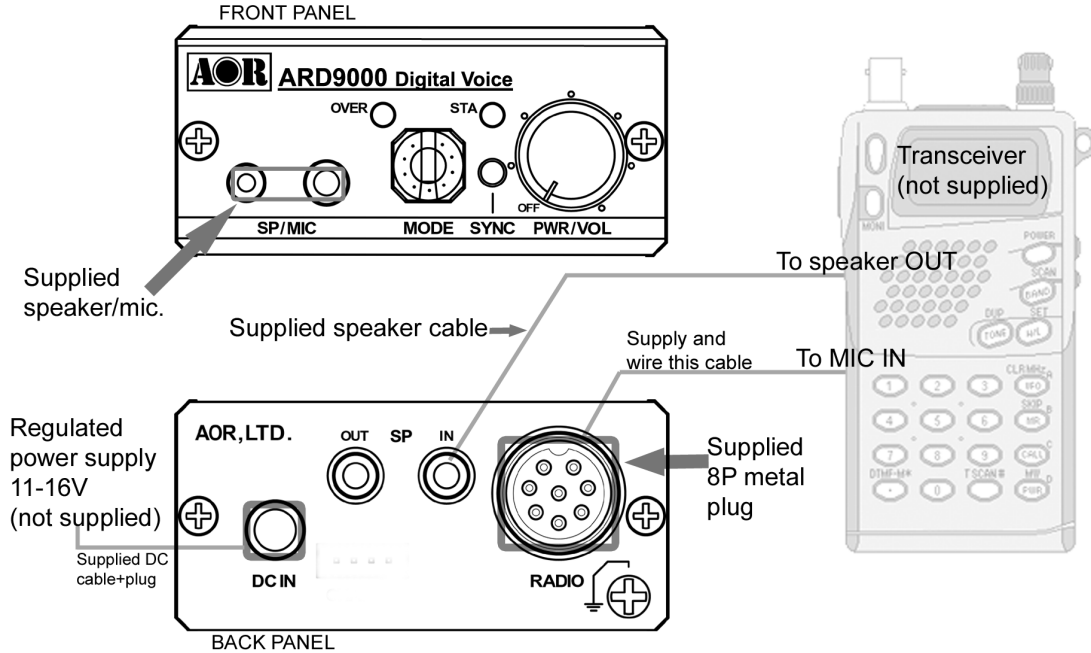

Magnetic mount

The supplied magnetic mount base holds the ARD9000 in place against any metal surface. Simply screw it to the bottom panels center hole as displayed below:

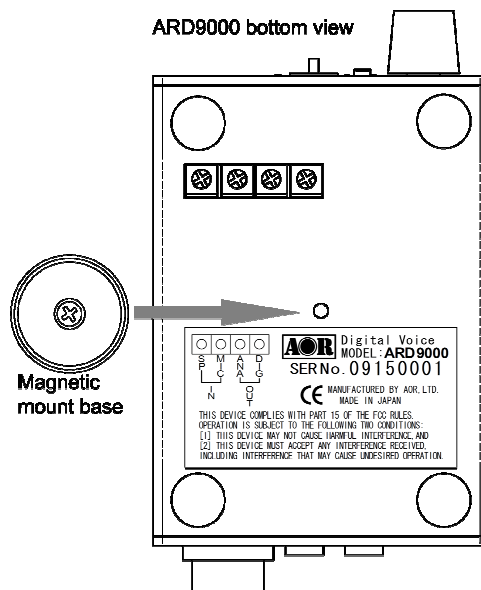

Controls and Functions

Front Panel

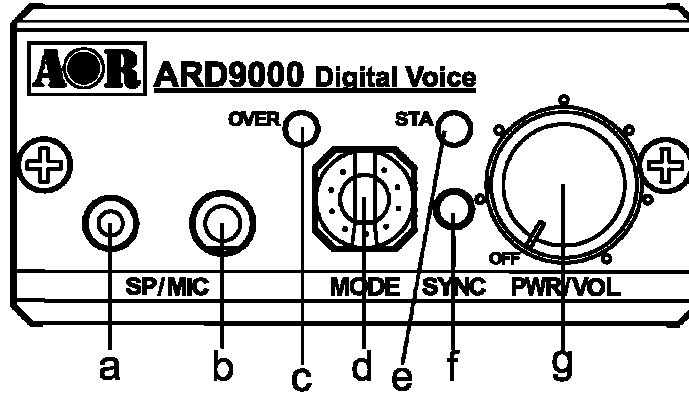

The supplied speaker-microphone is provided for your convenience. However if you prefer not using the supplied speaker-microphone, or a speaker-microphone of another standard, please read following points -aa and bb

a. **SPEAKER OUT Connector (2.5 mm mono jack)**

Insert the supplied speaker-microphone into the connectors -aa and bb
If you wish to use your own headphone, then connect it to aa

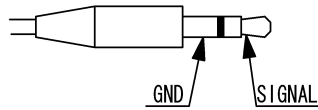

b. **Microphone connector (3.5 mm stereo jack)**

Insert the supplied speaker-microphone into the connectors -aa and bb
If you wish to use your own microphone, then connect it to bb

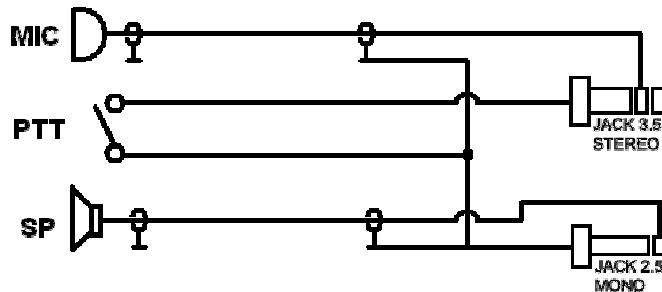
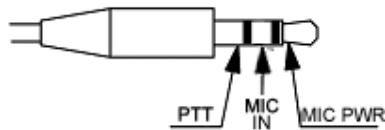

Speaker-microphone connection diagram:

c. Overload indicator

1) Microphone level (transmission only)

Lit when the microphone input is overloaded in transmitting voice. A proper microphone input level will light the LED from time to time when speaking into the microphone at a normal voice level. The microphone level can be changed by adjusting the microphone level controller.

Refer to the Presetting - Microphone Level chapter for details.

2) Input level indicator (for reception or standby)

To set the optimum level of audio from the transceiver (crucial for good decoding of digital signals), this LED operates as an input level indicator in receive mode, as follows:

<i>LED flashing</i>	<i>Input level too low</i>
<i>LED off</i>	<i>Input level optimal</i>
<i>LED always on</i>	<i>Input level too high</i>

d. Mode Rotary Switch

There are 10 modes to chose from, as follows:

Position	Mode	Header	Analog/digital switch	
0	SSB	1.6 sec	PTT->A	
1	SSB	1.4 sec.	PTT->A	
2	SSB	1 sec.	PTT->A	
3	SSB	1.6 sec.	PTT->B	
4	SSB	1.4 sec.	PTT->B	
5	SSB	1 sec.	PTT->B	
6	FM (*)	1 sec.	PTT->B	Voice squelch
7	FM (*)	1 sec	PTT->B	All digital
8	FM (*)	0.5 sec	PTT->B	Voice squelch
9	FM (*)	0.5 sec	PTT->B	All digital

Details:

Header stands for the header tone length. The ARD9000 synchronizes on the header tones at the initial contact with other users.

PTT->A allows to toggle between analog and digital transmission just by shortly pushing the PTT button. The second press opens the microphone and allows you to talk.

PTT->B Pushing the PTT button half way through toggles the analog/digital mode, continue and fully press the PTT to open the microphone and talk.

Voice squelch: Allows you to hear both analog and digital transmissions.

All digital: The only audio you will hear is when the ARD9000 detects and decodes a digital transmission.

(*): In FM mode, the ARD9000 operates best when your transceiver squelch is fully open.

e. **Status LED**

SITUATION	LED
Analog standby	Off
Digital standby	Green
Analog transmit	Red
Digital transmit	Orange
Digital receive	Green blinking

f. **Synchronization push button**

Enables the re-synchronization of digital reception if synchronization is lost during a communication session.

g. **Power / volume knob**

Only applicable for DIGITAL reception.

Adjustment for speaker/headphone output level, as well as for the speaker output on the rear panel. Turning the knob fully counterclockwise, switches the unit off.

At ANALOG reception, the audio is bypassed directly to the speaker, and the volume level has to be adjusted with the transceiver's volume control. As long as the ARD9000 is powered on, even if the volume knob is turned fully counterclockwise, audio output from the transceiver is bypassed to the ARD9000 speaker.

Rear Panel

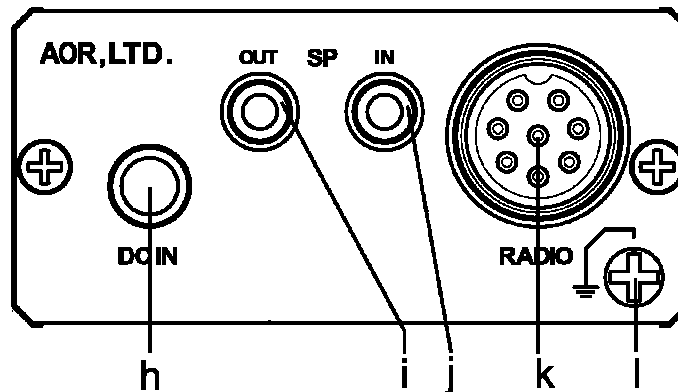

h. **DC IN Connector (EIAJ Type 4)**

Using the supplied DC power cable, connect to your regulated power supply (10~16V DC, center pin ? positive). We strongly recommend to use the separated power unit from that of transceiver.

Color
 RED
 BLACK

Polarity
 Positive (+)
 Negative (-)

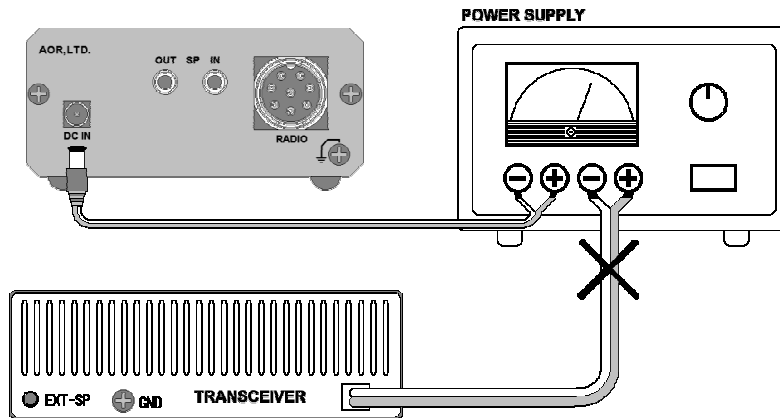

i. SPEAKER OUT Connector (3.5 mm mono jack)

To connect an external speaker (not supplied). Once connected, the speaker-microphone-s speaker is disabled.

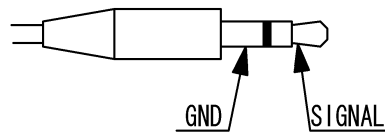

j. SPEAKER IN Connector (3.5 mm mono jack)

Connect to the transceiver's speaker output with the supplied cable.

(Input level: 0.5V ? 5V p-p, input impedance: 8 Ohm)

Do not connect other audio sources like your radio's ACC-connector or LINE-OUT as audio levels are insufficient for the ARD9000 to function normally.

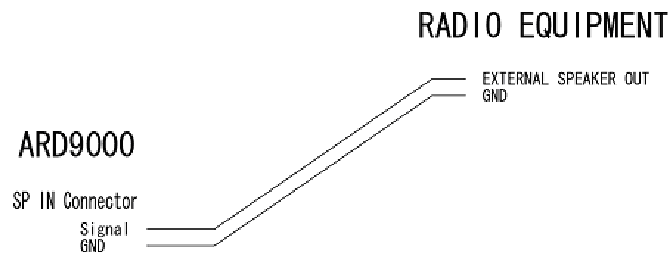
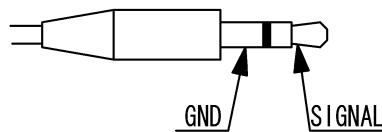

k. **RADIO Connector**

Using the supplied 8-pin connector, connect the ARD9000 to your transceiver's microphone input.

You will need to prepare your own microphone connector and cable for your transceiver.

Wire a cable according to the microphone connector specifications of your radio (refer to your radio operator's manual)

Below are the pin assignments of the ARD9000 connector.

<u>Pin number</u>	<u>Signal</u>	<u>Details</u>
1	MIC GND	Microphone ground
2	MIC OUT	Microphone Output
3	PTT (H)	PTT output (High level)
4	PTT (L)	PTT output (Low level)
5	NC	No connection
6	NC	No connection
7	GND	Ground
8	NC	No connection

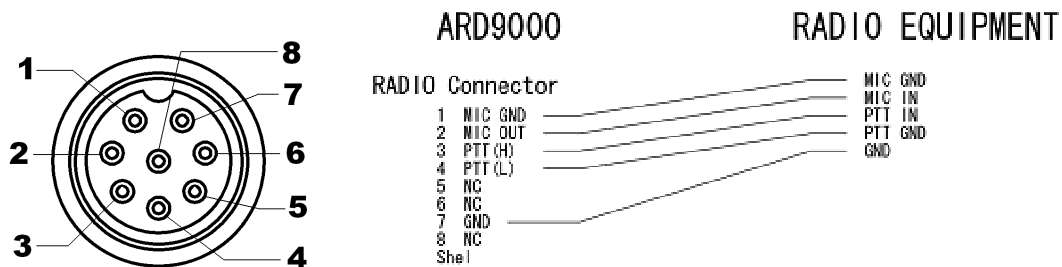

Note: MIC GND and GND must not be connected together in the ARD9000 connector, or RF feedback will result.

l. **FG Screw**

Frame ground. When you use the ARD9000 with a base transceiver, you have to connect this FG with the earth terminal of transceiver by using a short and low impedance wire (not supplied).

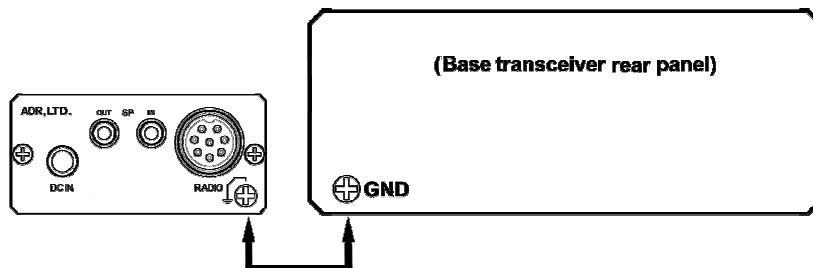

Presetting

Microphone Level

The microphone level has been properly adjusted at the factory with the provided speaker-microphone. Therefore, no further adjustment is needed for normal operation.

If you wish to use your own microphone rather than the included one, you will need to wire your microphone connector to match the pins of the ARD9000, and then adjust the microphone level as described in the following steps:

1. Connect your microphone to the Microphone connector on the ARD9000.
2. Make sure that the **input level pot** MIC-INI is set to factory default.

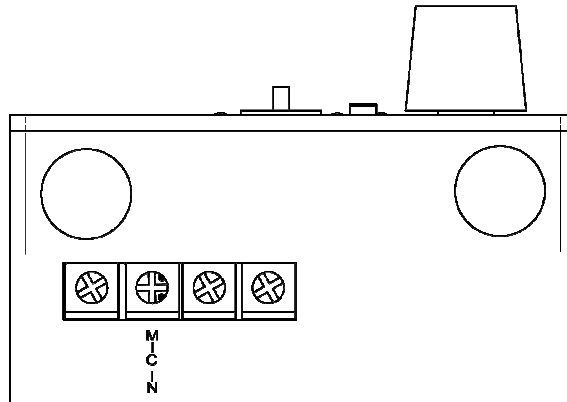

3. Press PTT switch on your microphone and speak normally into the microphone.
4. The OVERLOAD LED is lit either red for analog, or orange for digital transmission (depending on your rotary switch position). Adjust the MIC-INI pot, on the bottom side of the ARD9000, by observing the OVERLOAD LED as follows:

<i>LED off</i>	<i>Input level too low</i>
<i>LED sometimes lit</i>	<i>Input level optimal</i>
<i>LED always on</i>	<i>Input level too high</i>

Output Level to Radio

Before modifying the output levels to the transceiver, be sure that the microphone level is correctly set first, as described in the previous chapter. Although the factory setting should work with most transceivers, it is possible to adjust the audio output level manually, as described below. This level must be

correctly set to enable effective operation with your transceiver.
The ARD9000 allows you to apply separate settings for analog and digital transmissions (also see the diagram below).

1. Connect the supplied speaker microphone to the ARD9000 first, then connect your radio to the RADIO terminal of the ARD9000 by using your prepared connection cable. Now turn ON the ARD9000.
2. Make sure that the **output level pot** ANA-OUT or DIG-OUT is set to factory default.

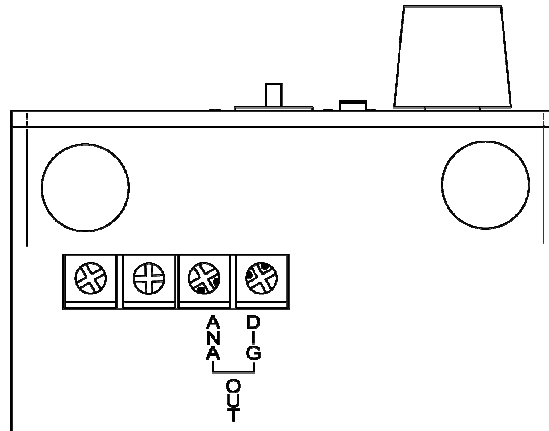

3. Press PTT switch on the supplied speaker microphone and speak normally into the speaker-microphone.

In case the OVERLOAD LED is not lit, it means that the microphone MIC-IN level has not been set properly. Refer to the previous IMicrophone level chapter to correct this level first.

4. Adjust microphone gain control on the radio transceiver to suitable level. It is recommended that you adjust the level so that the ALC function is activated. If the ALC function activates too much, it might create audio distortion and as a result, the communication link with the distant station may be broken.
5. Adjust the **output level pot** on the bottom side of the ARD9000 when the microphone gain control on the radio transceiver does not adjust for sufficient level.

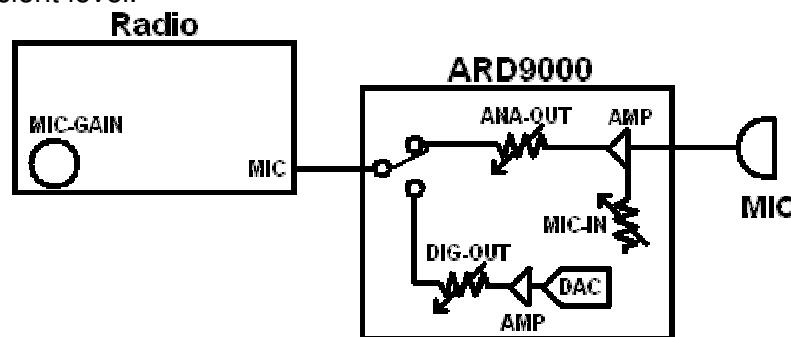

Input Level from Radio

Analog voice:

The ARD9000 does **not** provide any sound amplification for analog voice! Analog voice from your radio is bypassed directly to the ARD9000 speaker and has to be adjusted with your radio's audio gain control (as per diagram below).

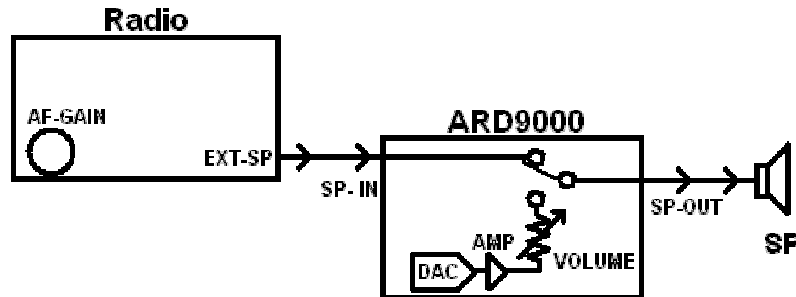

Digital Voice:

Although the factory setting should work with most transceivers, it is possible to adjust the audio input level manually. This level must be correctly set to enable effective operation with your transceiver.

If, and only if you are unable to achieve the correct level, then adjust the **input level pot** SP-IN1 on the bottom side of the ARD9000:

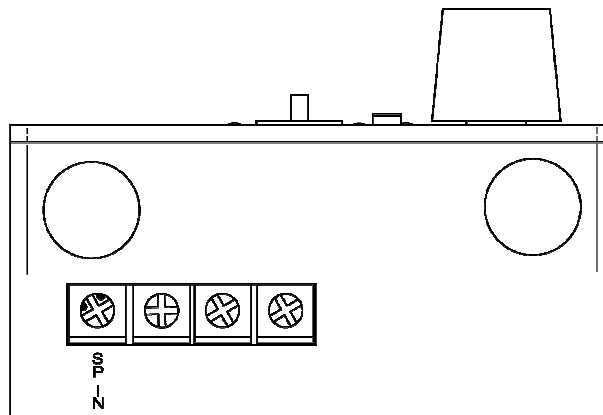

Apply adjustments by observing the OVERLOAD LED as follows:

<i>LED flashing</i>	<i>Input level too low</i>
<i>LED off</i>	<i>Input level optimal</i>
<i>LED always on</i>	<i>Input level too high</i>

Operation

Voice Communication

Your ARD9000 is capable of Digital Voice Communications and Analog Voice Communication. In the receive mode, the ARD9000 will automatically recognize the type of communication, and set the appropriate operation mode (analog or digital).

Remember that in order to receive SSB transmissions, you need to set the ARD9000 to SSB mode, and in FM mode to receive FM transmissions.

The operation modes can be selected with the MODE ROTARY SWITCH, labeled and described in chapter Controls and Functions

Factory default

If you wish to revert the ARD9000 sound level pots (located on the bottom panel) to default status, adjust the levels as pictured below.

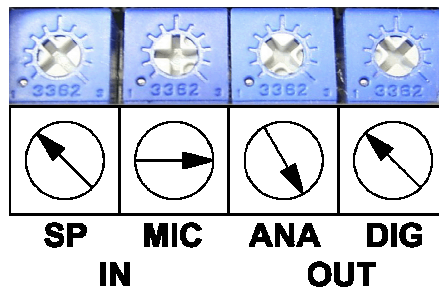

Specifications

ARD9000 Specification	
Modulation method:	OFDM
Bandwidth:	300 Hz - 2500 Hz, 36 carriers
Symbol Rate:	20 mS (50 baud)
Guard interval:	4mS
Tone steps:	62.5 Hz
Modulation method:	36 carriers: DQPSK (3.6K)
AFC:	+/- 125 Hz
Error correction:	Golay + Hamming
Header:	0.5-2sec. 3 tones + BPSK training pattern for synchronization
Digital voice chip:	AMBE2020 coder, decoder
Signal detection:	Automatic Digital detect, Automatic switching between analogue mode and digital mode
Power requirements:	10-16V DC, Approximately 100 mA Typ @ 12 V DC
Weight:	175g.
Dimensions (w, h, d):	70 x 33 x 98 (mm) Projections excluded.
Connectors:	MIC/SP, Radio, DC-IN, SP-IN, SP-OUT.
Supplied access.:	Speaker-microphone, DC cable, SP cable, 8-pin Radio connector, magnetic mount base with screw, instruction manual.
Options:	Pre-wired microphone interface cable for most popular transceivers.

Specifications subject to change without notice or obligation.

Addendum

Audio buzz in analog mode

The ARD9000 is popular and selling well, since its introduction to the amateur radio market on May 2005. The supplied speaker/microphone works very well, as the modem settings are optimized for this particular speaker/microphone.

Some of our customers have pointed out that if another microphone is used and the audio settings not carefully adjusted, that the ARD9000 might not function correctly, or that an audio buzz appears in analog mode.

To avoid such problems it is strongly advised to proceed as follows:

- Deactivate your transceiver's speech processor.
- If you wish to use your own speaker/microphone, you might need to adjust the MIC IN pot on the bottom side of the ARD9000.
- Although the default ANA-OUT level should work for most transceiver types, it might be necessary for you to adjust that level. If the level is too high, your transceiver might overload and an audio buzz or other audio distortion might be audible and transmitted. You can avoid this, by carefully reducing the gain with the ANA-OUT pot.

If the above instructions are followed, then your own microphone should perform as well as the supplied speaker/microphone.

It is not necessary to adjust the sound level pots if your unit is functioning correctly from the beginning.

July 29, 2005

AOR, LTD.
2-6-4, Misuji, Taito-Ku
Tokyo, 111-0055, Japan
<http://www.aorja.com>

Copyright © 2005
All rights reserved