

## DATONG ELECTRONICS LIMITED

Spence Mills, Mill Lane, Bramley, Leeds LS13 3HE, England. Telephone: 0532 552461

- \* A fully aligned and tested printed circuit module as used in the Datong "Universal r.f. Speech Clipper".
- \* Greatly increases 'punch' or 'talk-power' when connected between microphone and transmitter, yet, without introducing harmonic distortion.
- \* Ideal for use with SSB, AM, or FM transmitters.
- \* Advanced circuit uses seven analogue and digital integrated circuits.
- \* Very wide supply voltage tolerance (6 to 15 volts) and low current drain.
- \* Glass-fibre P.C. board and professional quality components.

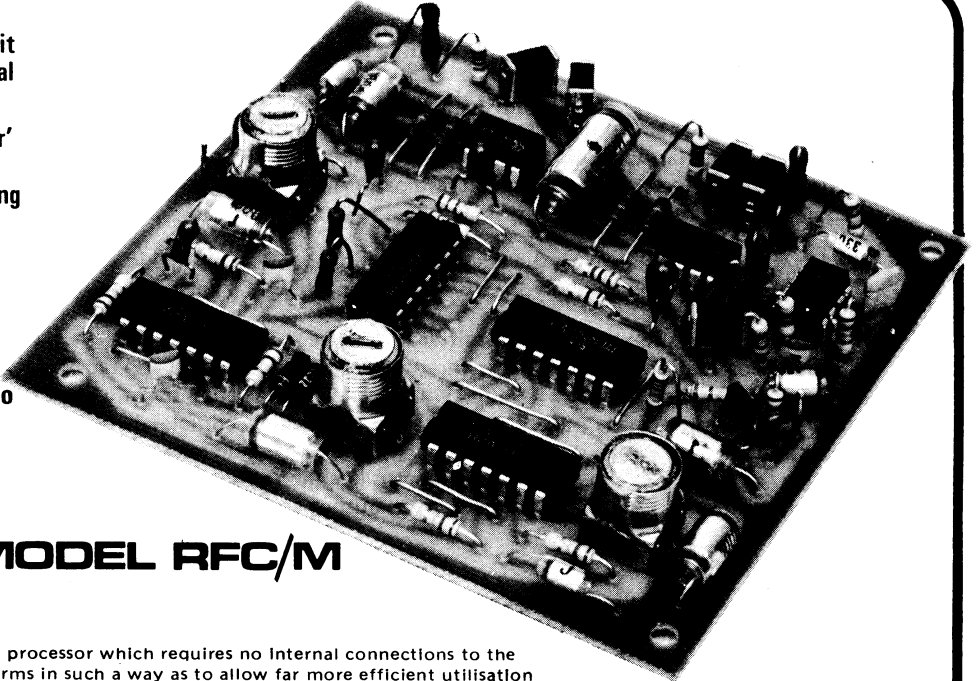

### MODEL RFC/M

#### FUNCTION

The module is a radio frequency speech processor which requires no internal connections to the transmitter. It processes speech waveforms in such a way as to allow far more efficient utilisation of the peak modulation capabilities of conventional radio transmitters, and to give increased intelligibility in difficult reception conditions. In effect the transmitter becomes equivalent to one with a peak power rating (or deviation) up to about ten times greater, yet distortion introduced by the device is subjectively negligible.

#### DESCRIPTION

The Datong r.f. speech clipper module first translates the incoming speech frequencies up to a frequency of 60 kHz as a single sideband suppressed carrier signal. This SSB signal is amplitude limited and filtered and then re-translated back to audio frequencies. After low-pass filtering the r.f. clipped audio signal appears at the output terminal with a well-defined peak amplitude which is independent of the amplitude of the input signal.

Compared with devices which clip the audio input signal directly, this advanced method of speech processing has the advantages that the distortion is subjectively negligible and that the output is quite suitable for driving SSB as well as AM and FM transmitters. Compared with a.g.c. type audio frequency compressors the Datong r.f. speech clipper does not suffer from limitations due to finite response time and gives significantly better enhancement of "talk-power." \*

\* These differences are discussed in more detail in the following articles by Dr. D. A. Tong (G8ENN), "A.f. and r.f. clipping for speech processing", Wireless World, February 1975, pp 79-82, "The r.f. clipping advantage", Short Wave Magazine, October 1974, pp 422-426.

When the Datong r.f. clipper module is correctly used the results are comparable to those obtained using a linear amplifier with 6-10db power gain. This applies at any operating frequency and even if you already run full legal power. In the case of FM or AM you sound much louder and more intelligible for a given peak deviation or modulation depth and this is of great benefit when operating near the limits of range.

#### WIRING AND MOUNTING INSTRUCTIONS

The following connections must be made to the module: power supply, audio input, audio output.

Two solder terminals are provided for the power source, the one for the negative line being connected to system ground (the peripheral copper track on the P.C. board). Therefore if the module is powered from an external supply it must be one with "negative earth". With systems having a "positive earth" a separate 9 volt battery should be used for the module.

Connections to the module are shown on the diagram, together with peripheral components. The 10 volt zener diode (D1) and resistor R1 are used to ensure that the power supply voltage seen by the module never exceeds 15 volts, even transiently. These components should always be used when the module is operated from the electrical system of a car. The value of resistor R1 is calculated from

$$R1 = (V_{in} - V_{zener}) / 10 \text{ Kilohms}$$

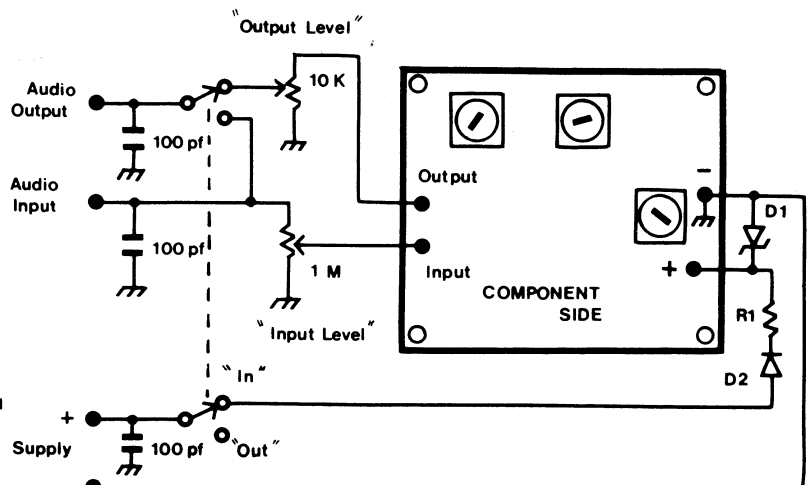

If there is no possibility of the power supply voltage exceeding 15 volts, even transiently, D1 and R1 may be omitted. Almost any low power zener diode in the range 8-10 volts is suitable, for example the BZY88C10V.

The series diode, D2 provides protection against accidental reversal of the power supply polarity. Such protection is not built into the basic module and is strongly recommended. Almost any silicon diode can be used, such as 1N916, 1N4148, 0A200, etc.

The 1 megohm input potentiometer shown on the diagram allows the output from the microphone to be adjusted so as to give the degree of clipping required. With the potentiometer omitted or set to maximum, the microphone must give 80 mV peak-to-peak (typical) for 20db of r.f. clipping. The majority of microphones in current use give more than this. The load resistance presented by the clipper module is nominally 560K.

The 10K output potentiometer allows the 400 mV peak-to-peak output voltage from the module to be reduced if required to suit the actual input sensitivity of the transmitter. If the output potentiometer is set to maximum, the external load resistance should be greater than 4K, but if the potentiometer is reduced to less than half-way load resistances down to zero can be applied (although there will be a corresponding reduction in the output voltage from the module).

The "in/out" switch shown on the diagram is optional and allows the input signal to by-pass the clipper module if desired. It also functions as an "on/off" switch for use with a battery power supply.

When the module is used with a transmitter it must be shielded from strong r.f. fields otherwise severe distortion or even continuous oscillations will occur when transmitting due to pick-up and rectification of r.f. energy by the low-level audio stages. The extent of shielding required will depend on the actual situation but it is strongly recommended that the module be mounted, using the brass pillars supplied, inside a completely enclosed metal box. The input and output connections should also be decoupled to r.f. by 100 pf ceramic capacitors as shown on the connection diagram. To be effective the capacitors should have lead lengths less than about 1 cm, and should be mounted with one side connected to the metal case and the other to the input or output connector.

#### IMPORTANT NOTE:

The tips of some soldering irons may have an alternating potential with respect to mains earth due to internal leakage. In severe cases the potential could exceed the maximum supply voltage rating of the module. To avoid any possibility of damage to the module the following precautions should be taken: (1) Make sure that the soldering iron is earthed; (2) Make a direct connection from the tip of the soldering iron to the negative supply voltage terminal on the module; (3) Disconnect the module from any other equipment when soldering to the terminals.

No responsibility for damage or malfunction can be accepted if any soldering is carried out to points on the module other than to the four solder tags provided, or if any unauthorised attempt is made at modification or repair.

#### OPERATING INSTRUCTIONS

When the unit is wired as described above the method of setting the controls and of using it with a transmitter is the same as with the normal Datong "Universal r.f. speech clipper" and the same instruction sheet is supplied with the module as with the complete ready-to-operate units.

#### TECHNICAL DATA

(Except where stated, the data quoted represent typical values obtained using a supply voltage of 9 volts).

Input sensitivity at 1 kHz at clipping threshold (Note 1)	8mV pk-to-pk
Input impedance	560K shunted by 82 pf.
Output at clipping threshold	400mV pk-to-pk
Degree of r.f. clipping obtainable before the input stage begins to limit (Note 2)	26 db
Signal-to-noise ratio at clipping threshold	45 db
Frequency response for inputs below clipping threshold	-3 db points at 450 Hz and 2.6 kHz
Supply voltage range (Note 3)	6 to 15 volts
Supply current	18 mA at 15 volts, 12.5 mA at 12 volts, 8 mA at 9 volts, 4 mA at 6 volts.
Minimum External Load for full output	4K
Dimensions	90 x 98 mm. Height above board 13 mm.
Fixing centres	80 x 85 mm.

#### Notes

1. The clipping threshold is reached, by definition, when the output is 3 db below its maximum level
2. More than 15-20 db of clipping is not normally required.
3. The upper limit should not be exceeded even momentarily. The negative side of the supply is connected to the peripheral copper track and hence to the mounting pillars.
4. The right is reserved to vary these parameters in the light of continuing development.

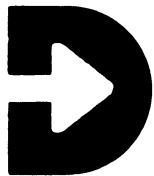

## DATONG ELECTRONICS LIMITED

Spence Mills, Mill Lane, Bramley, Leeds LS13 3HE, England. Telephone: 0532 552461

### UNIVERSAL R.F. SPEECH CLIPPER

#### INSTALLATION AND OPERATING INSTRUCTIONS

These notes are intended to be read in conjunction with and to augment the basic information given on the product data sheet.

#### INTERCONNECTION

- 1. The output lead.** Suitable output leads are available from Datong Electronics Ltd. as optional accessories and allow the clipper to be plugged directly into many different makes of transmitter. These leads are wired according to the pin connections shown in the block diagram on the clipper data sheet. Pin 3 of the 5 pin DIN plug carries the output signal from the clipper and pin 1 carries the push-to-talk line. Each of these two wires is separately screened with the screens connected together at pin 2 of the DIN plug. Pin 2 is also connected to the shell of the plug. Pins 4 and 5 are joined within the plug so that the internal battery is brought into use when the lead is plugged in.
- 2. The input socket.** Many transmitters already use a standard stereo-type jack for the microphone connection. A microphone fitted with such a plug will connect directly to the Datong Clipper (assuming the connections are the same). In other cases either an adaptor lead will have to be used, or the microphone plug will have to be replaced by a jack plug. It should be wired as shown in the block diagram, i.e. with the microphone lead to the "tip" and the push-to-talk lead to the "ring". The sleeve is the common earth return. If the existing microphone plug is changed to a stereo jack plug, the original plug can be fitted to the end of the clipper output lead. A suitable ready-made lead is then RFC/FREE.

#### SETTING THE CONTROLS

In order to obtain the best results with the Datong Clipper (or any other) it is important that it be used correctly and this requires some appreciation of the quite different functions of the two level controls on the clipper. The key difference between them is that the "output level" knob controls the signal level **after** the clipping process, whereas the "input level" knob controls the amplification of the microphone signal **before** it is processed and subject to r.f. clipping. This is indicated on the block diagram.

Because the clipping stage defines a fixed upper limit for any input signal above the clipping threshold, the "input level" control has no effect on the **peak** output amplitude; instead it controls the degree of clipping. It has, therefore, a large effect on the **average** amplitude of the output signal.

The "output level" control on the other hand should be regarded as a preset control which, when the clipper is switched to "in", has the same effect as the microphone gain control on the transmitter. It is included as a convenience to the operator since it allows the peak output from the clipper to be set equal to the peak output from the bare microphone. Operation of the "in/out" switch then allows a direct comparison to be made of the effectiveness of the clipper. Note that in the "out" position the microphone is connected directly through to the output socket and the internal or external battery is disconnected.

- 1. Setting up for SSB without using test equipment.** Having installed the clipper as already described, switch to "out", and tune and load up the transmitter and set the transmitter microphone gain control in the normal way for negligible "flat-topping". The microphone gain control should subsequently remain fixed.

Then switch the clipper to "in", set the "input level" control to maximum and "drone" into the microphone. Adjust the "output level" control on the clipper until the P.A. anode current meter indicates the peak value recommended for the particular transmitter. Finally, reduce the setting of the "input level" control until the desired degree of clipping is achieved (see later).

If the transmitter has an a.l.c. meter it is probably better to use the recommended a.l.c. meter reading rather than the P.A. anode current reading as the criterion for setting the gains in the above procedure.

When the clipper/transmitter combination has been set up in the above manner it is wise to ask several fairly local stations to check the transmitted signal for "splatter". Slight "flat-topping" can go relatively unnoticed when no speech processing is used but can cause annoying interference to others when speech processing is used because then the peaks occur for a much larger fraction of the time. The optimum setting for the "output level" control is that which gives the highest P.A. anode current consistent with no splatter.

Once correctly set up, the Datong Clipper ensures that no matter how loudly you talk into the microphone the transmitter will not flat-top.

- 2. Setting up for SSB using an oscilloscope.** If an oscilloscope or other device to detect the occurrence of "flat-topping" is available, proceed as follows:
  - (a) Set up the oscilloscope to monitor the **output** signal from the transmitter.
  - (b) With the clipper switched to "out", "drone" (rather than whistle) into the microphone and adjust the microphone gain control on the transmitter until "flat-topping" is only just apparent on occasional peaks.

(c) Do not readjust the transmitter gain control. Switch the clipper to "in", set the "input-level" control to maximum, and again "drone" into the microphone. Adjust the "output level" control on the clipper until "flat-topping" just fails to occur on peaks. Note that the oscilloscope trace shows a far higher average output level than when the microphone is used alone.

(d) Adjust the "input level" control to give the desired degree of clipping.

**3. Setting up for AM transmitters.** The procedure is in general the same as already detailed for SSB except that AM transmitters normally have no means of monitoring the modulation depth. As in AM operation without a speech processor, the important thing is to use as large a depth of modulation as possible without over-modulating on peaks. The ideal way to check this is with an oscilloscope, but failing that, a good indication is obtained by checking for the absence of "splatter" adjacent to the transmitter frequency.

If the transmitter is fitted with a modulation limiter the output level from the Datong Clipper should be adjusted so that the limiter just fails to operate on peaks.

**4. Setting up for FM transmitters.** The same comments apply as for AM except that for "overmodulation" read "overdeviation". Also of course an oscilloscope is of no value in setting up the deviation.

#### CHOICE OF CORRECT CLIPPING LEVELS

This is best found by experiment since it depends on the characteristics of both the voice and the microphone. A setting of the "input level" control can be found where the sensitivity to weak sounds is the same with either setting of the "in/out" switch. This represents the situation where the extent of clipping is slight. As the "input level" is increased further from this point, more clipping occurs and the average reading on the P.A. anode current meter will increase. This represents part of the gain in talk-power.

The greater part of the considerable talk-power gain achieved by clipping occurs with the first 10 to 15 db.

A good way to get the feel of what the "input level" control does is to feed the audio output from pin 3 of the output socket into a tape recorder. Test recordings should then be made with various settings of the "input level" control.

When signals are very weak it is worthwhile using the maximum available clipping since any slight changes in voice characteristics will be completely masked.

#### SUITABILITY OF MICROPHONES

The input characteristics of the Datong Clipper were chosen to suit the large majority of microphones currently in use. The sensitivity of the input is high: only 8 mV peak-to-peak (i.e. 4 mV peak, or 2.8 mV r.m.s. sine wave) are needed to reach the threshold of clipping. It follows that 80mV peak-to-peak on voice peaks is sufficient to give 20db of clipping. This is probably the maximum which will be required. Most ceramic or magnetic microphones are suitable. It is helpful to speak more closely into the microphone when using speech processing in order to suppress room echo and background noises.

#### BATTERY REPLACEMENT

The battery should be replaced when its voltage has dropped to 6.5. Its voltage is easily monitored at pin 4 of the output socket without opening the case of the clipper. Although the clipper may still appear to work at supply voltages as low as 4, the dynamic range of the input amplifier will be reduced and this will introduce harmonic distortion.

#### EXTERNAL POWER SOURCES

When an external power supply is used note the following points: (a) The "in/out" switch on the clipper still operates normally. (b) The clipper is still protected against the application of reversed power supplies. (c) The absolute upper limit for the supply voltage is 15.5 volts. Supplies greater than this require that a dropper resistor be connected in series. A suitable value in Kilohms is given by  $(\text{Battery voltage} - 12) / 8.5$ . (d) When operating the clipper from a 12 volt car electrical system a 10 volt zener diode should be connected with its anode to pin 2 and cathode to pin 5 of the DIN socket. The positive lead from the supply should then connect to pin 5 via a resistor of 680 ohms (¼ watt). The function of the diode is to protect against transient high voltages.

#### SOME GUIDELINES AND GENERAL NOTES FOR SSB APPLICATIONS

1. Many operators of SSB transmitters develop a habit of controlling the level at which they speak by monitoring the "kicks" on the P.A. anode current meter. If this is done when the clipper is in use its effect will be cancelled out. One must get used to seeing the meter spend most of its time near to its peak reading. Remember that once the system is set up correctly it is impossible to "splatter" by talking too loudly.

2. If the general opinion of receiving stations is that the clipper is having only a slight effect, it may be (a) because the "output level" is set too low, or (b) because it is set too high and the transmitter a.l.c. is operating too heavily, or (c) because when operating the transmitter with the clipper "out" you are talking-up the peak P.A. current to a higher level than the clipper allows when it is switched "in". Remember that "peaks" of P.A. current as monitored using the P.A. current meter are always substantially underestimated because a meter is too sluggish to respond properly to short duration peaks. When the clipper is "in" the meter gives a truer indication because the peaks occur so much more frequently. Thus if the P.A. current kicks up to the same reading with the clipper "in" or "out" the peak power output from the transmitter will be considerably higher with the clipper "out" and a pessimistic assessment of the value of the clipper will be obtained.

3. In SSB applications the amount of clipping which can be safely used depends on the average-power capability of the transmitter. Excessive clipping can reduce the life of the output valve(s) with a marginally rated transmitter, but any improvement in cooling efficiency around the output stage will be of direct benefit. Transmitters with blower cooling generally have better safety margins than those without. Initially it is wise to monitor P.A. temperatures until the capabilities of the transmitter are known.

It is important that background room noises are not amplified to such an extent that the transmitter is heavily modulated when speech is not present. This can be checked easily by watching the P.A. current meter. It is of great help to talk very closely into the microphone so that the "input level" control can be reduced for the same degree of clipping. Not only does this help to protect the P.A., it also helps to suppress room echo.

Obviously the output stages of the transmitter will be working harder when clipping is in use, therefore if the transmitter is only marginally rated, try to help by leaving longer gaps between sentences or words and reserve the higher clipping levels for use when really needed.

MODEL	RFC	REF/R	REC/A	REC/B
INPUT	JACK	JACK	4PIN	4PIN
P.T.T.	RING	TIP	3	2
SIG.	TIP	RING	2	1
GROUND	SLEEVE	SLEEVE	1	3&4

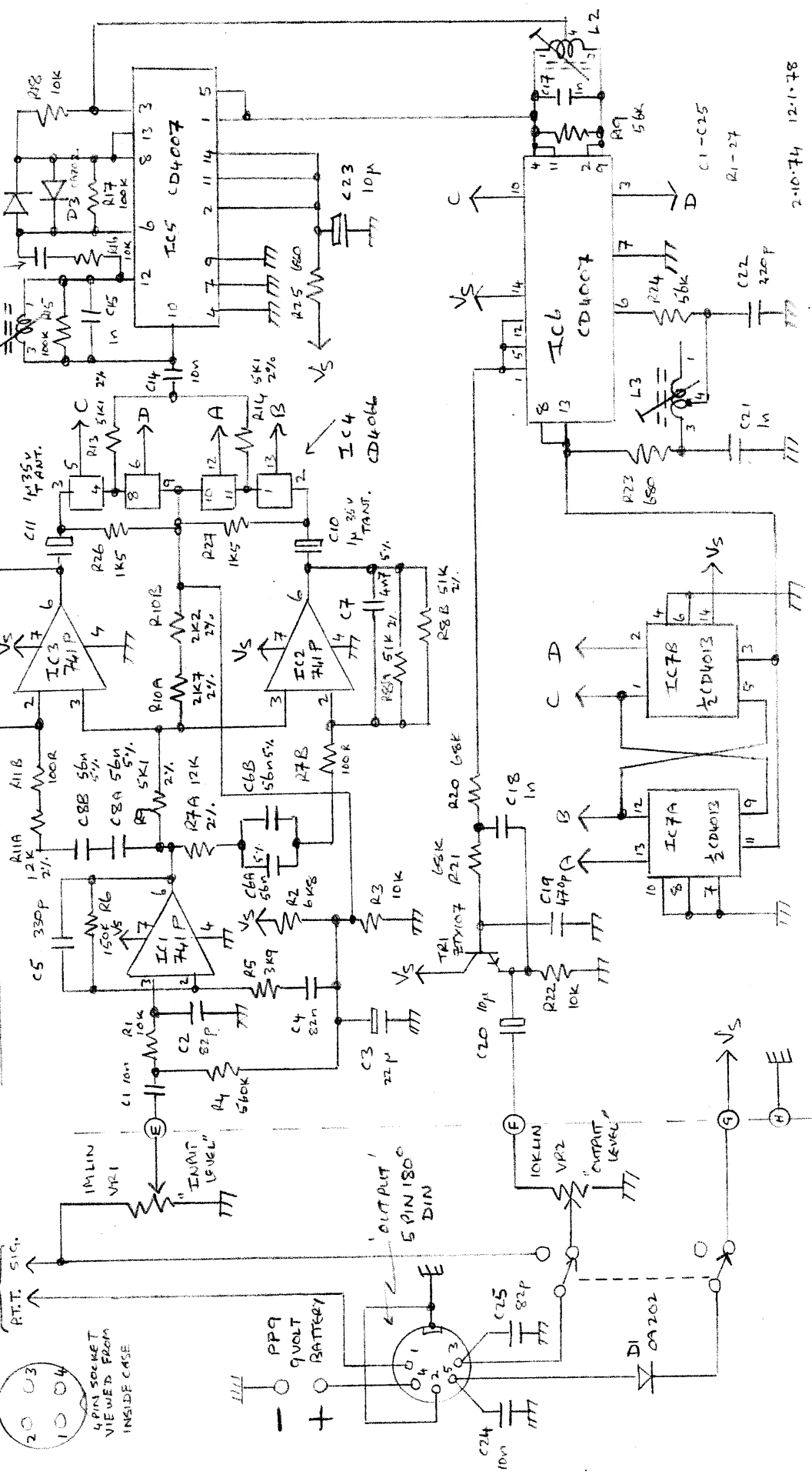
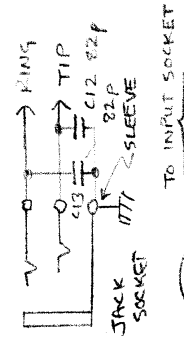

UNIVERSAL R.F. SPEECH CLIPPER