

Assembly Manual for the

VHF Wattmeter

K-6316

PLEASE READ DISCLAIMER CAREFULLY AS WE CAN ONLY GUARANTEE PARTS AND NOT THE LABOUR CONTENT YOU PROVIDE

Reproduced in part by arrangement with Electronics Australia, from their June 1986 Edition.

DICK SMITH
HIT

Are you getting the most out of your VHF rig? This VHF wattmeter measures RF power to 150W in both forward and reverse directions so that you can calculate SWR and check the efficiency of your antenna system.

Sooner or later, every amateur wants to measure transmitter power and transmission line SWR. Power measurements are particularly important when checking or servicing a transmitter to ensure that the unit is capable of delivering its rated power.

But it is not enough to simply adjust the transmitter for maximum power output. It is also necessary to ensure that

as much power as possible is radiated by the antenna. For this to occur, the antenna must be arranged to present the correct impedance match to the transmission line.

In amateur installations, the most commonly used form of transmission line is 50Ω coaxial cable. So, in order to match the cable, the input impedance of the antenna must also be 50Ω. Assum-

ing that the antenna is also resonant at the transmitter frequency, it will appear as a purely resistive load and will accept all of the RF energy arriving via the transmission line.

Now consider a situation where the antenna impedance does not match the transmission line — that is, we have an impedance mismatch. This could be due to the antenna not being resonant at the frequency of interest or due to mismatch at the feedpoint.

Depending upon the degree of mismatch, part of the RF energy will now be reflected by the antenna and will travel back down the line towards the transmitter. Thus, only part of the transmitted RF energy will be transferred to the antenna and subsequently radiated.

This is an undesirable situation because the reflected power tends to be dissipated in the cable, even if it is subsequently reflected back up the line by the transmitter. In cases of severe mismatch, damage may even occur to the output stage of the transmitter. And the greater the degree of impedance mismatch, the greater the reflected power and the greater the risk of damage.

Standing waves

Between them, the forward and reflected power components create standing waves in the transmission line. By measuring the forward and reflected power components, we can calculate the standing wave ratio (SWR) from the

Text and illustration courtesy of Electronics Australia

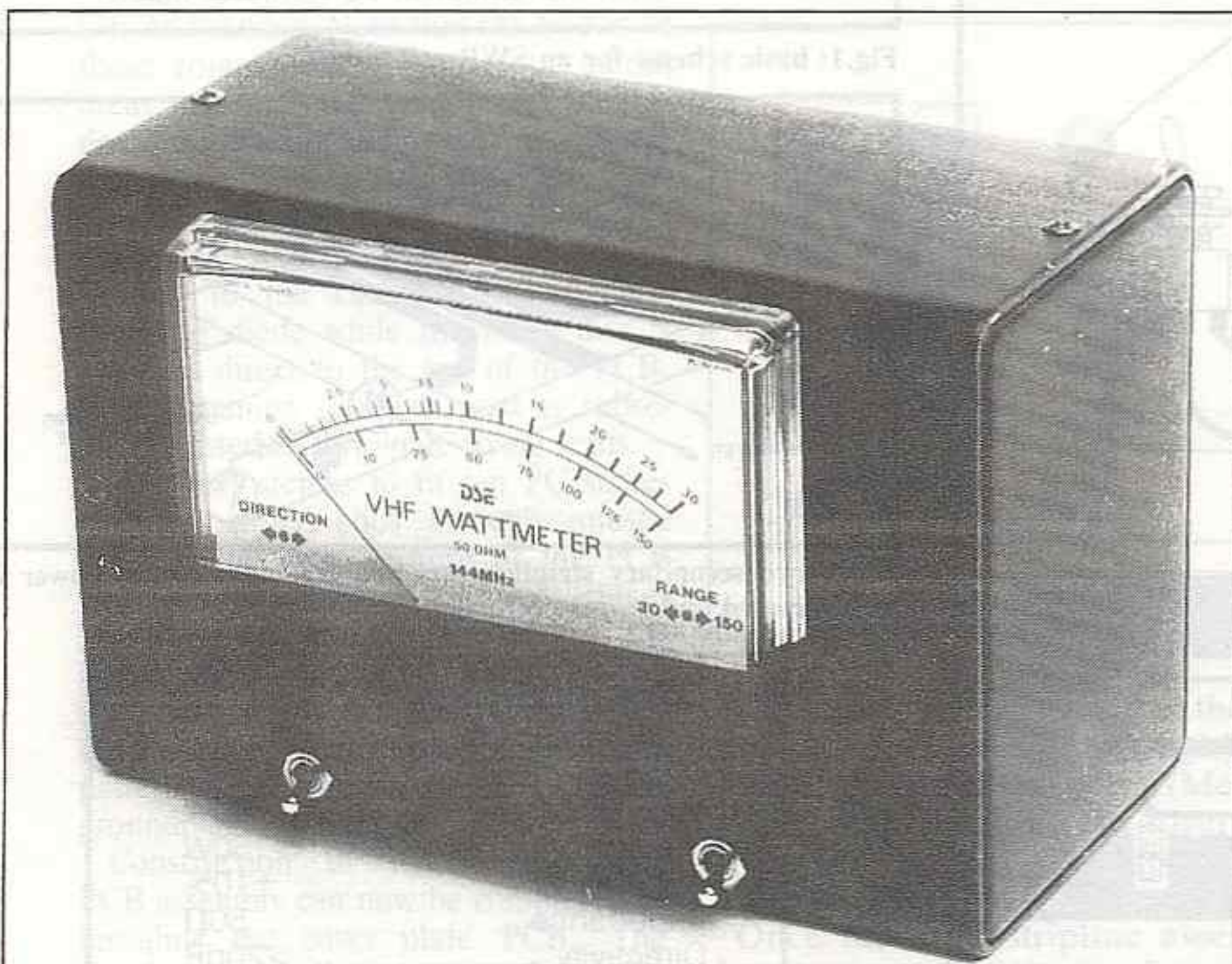

The VHF Wattmeter can measure RF power to 150W in both forward and reverse directions.

following equation:

$$(1). SWR = (\sqrt{P_f} + \sqrt{P_r}) / (\sqrt{P_f} - \sqrt{P_r})$$

where P_f and P_r are the forward and reflected powers respectively.

What does this mean in practice? Just this — in an ideal situation, the reflected power is zero and thus the SWR is equal to 1. This, in turn, means that the antenna is correctly matched to the transmission line and that the antenna system is operating at maximum efficiency.

In practice, the ideal situation is never achieved. Instead the aim is to tune the antenna for an SWR as close to 1 as possible. For a small amount of mismatch, the SWR will be around 1.1 or 1.2, increasing for a serious mismatch to 3 or beyond.

What the figures mean

In order to get some feel for the figures involved, let's take a look at a practical situation. Let's suppose that we have an SWR of 3 and that we're shooting 100W "up the stick". By substituting in equation 1, the reflected power turns out to be a quite substantial 25W.

From there, the situation deteriorates quite rapidly. For an SWR of 4, the re-

flected power is 36W, while for an SWR of 10, the reflected power rises to a massive 67W. Of course, some of this power will be reflected back to the antenna at the transmitter end but, by the time cable losses are taken into consideration, it adds up to a very serious loss indeed.

How it works

The VHF Wattmeter described here was developed by Gil McPherson, VK2ZGE for Dick Smith Electronics. Basically, it is an insertion type RF wattmeter capable of measuring power in both forward and reverse directions into a 50Ω load. These measurements are then used to calculate SWR, thus doing away with the fiddly controls and complex scales normally required on an SWR meter.

In fact, there are only two scales on the Dick Smith VHF Wattmeter: 0-30W and 0-150W. A switch selects the required power range.

Fig.1 shows the basic scheme of the VHF Wattmeter. Despite its rather strange appearance, the principle of operation is quite straightforward.

This type of device often goes under the high falutin' name of SWR Reflectometer and employs what are known as

microstriplines. A microstripline is simply a type of transmission line. It consists of a narrow conductor strip which runs parallel to a ground plane.

In Fig.1, we have two parallel microstriplines and these are arranged sufficiently close to each other to ensure that they are lightly coupled by virtue of their distributed mutual inductance and capacitance. As can be seen, one of these microstriplines is connected between the transmitter and the antenna while the other drives a rectifier diode and meter movement.

Here's what happens: When RF current flows down the "primary" microstripline towards the antenna, an induced RF current flows in the opposite direction in the secondary stripline. This current is then rectified and used to drive the forward meter movement.

Note, however, that current flowing in the secondary due to any reflected power is blocked by the diode and so does not affect the meter. Instead, the power is dissipated in load resistor R_a which is matched to the characteristic impedance of the secondary line.

To monitor the reflected power, we need to add a complementary secondary microstripline. Fig.2 shows the basic

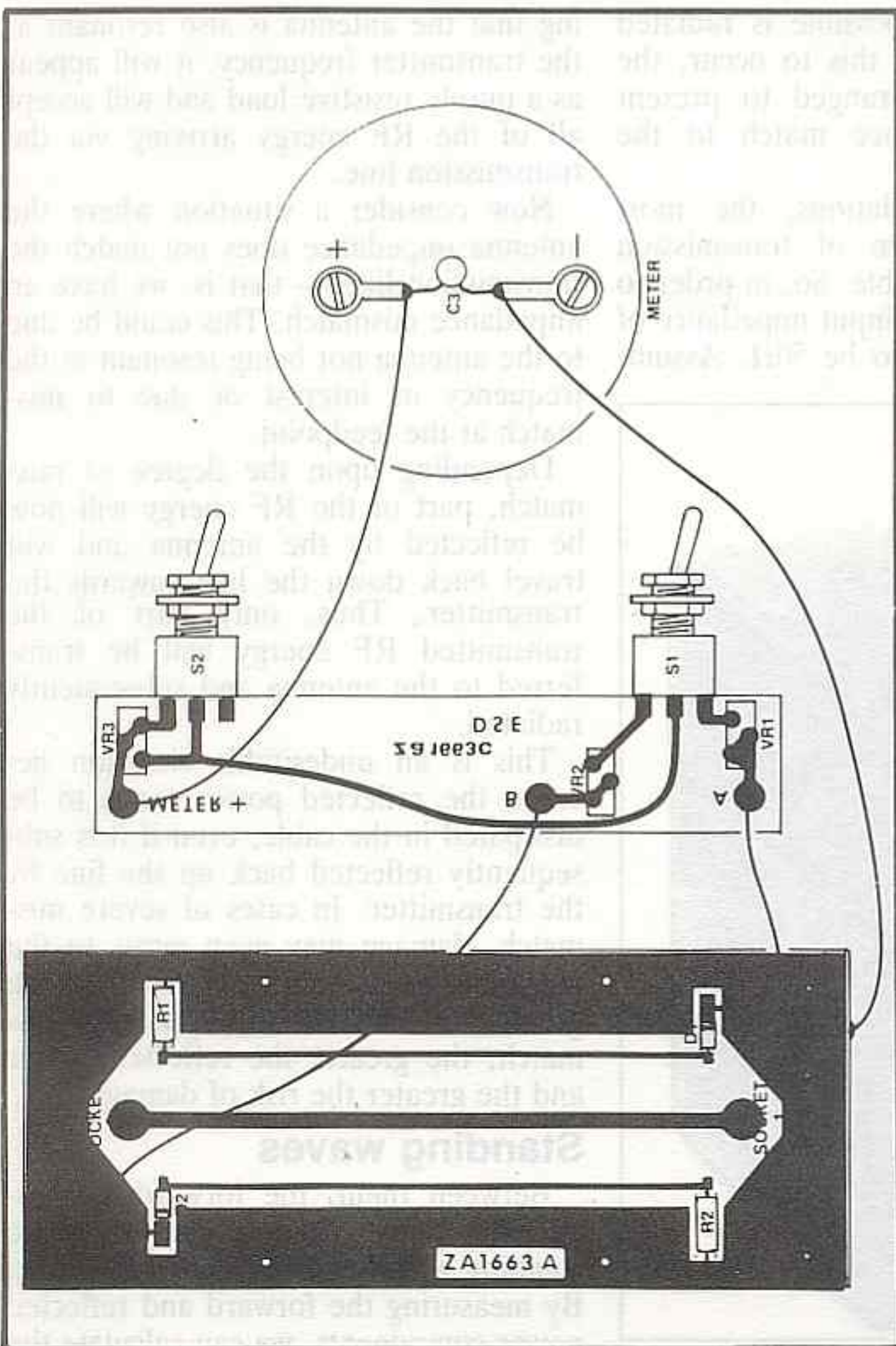

Fig.4: parts layout and wiring diagram for the VHF Wattmeter.

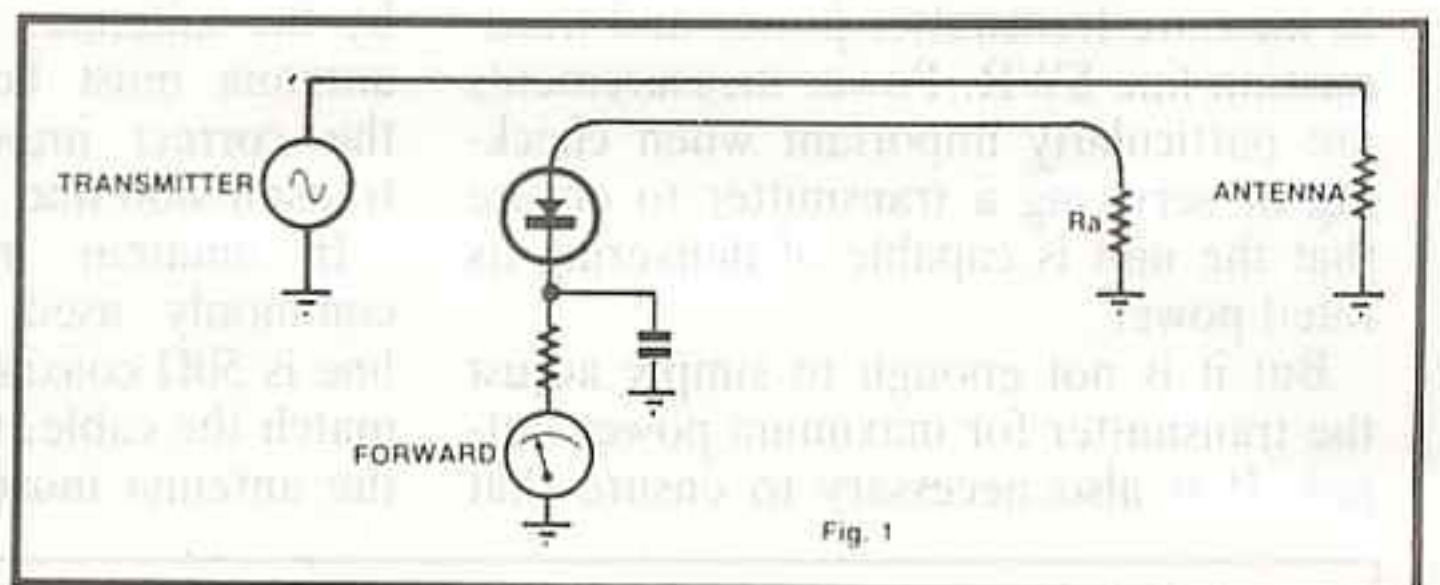

Fig.1: basic scheme for an SWR reflectometer.

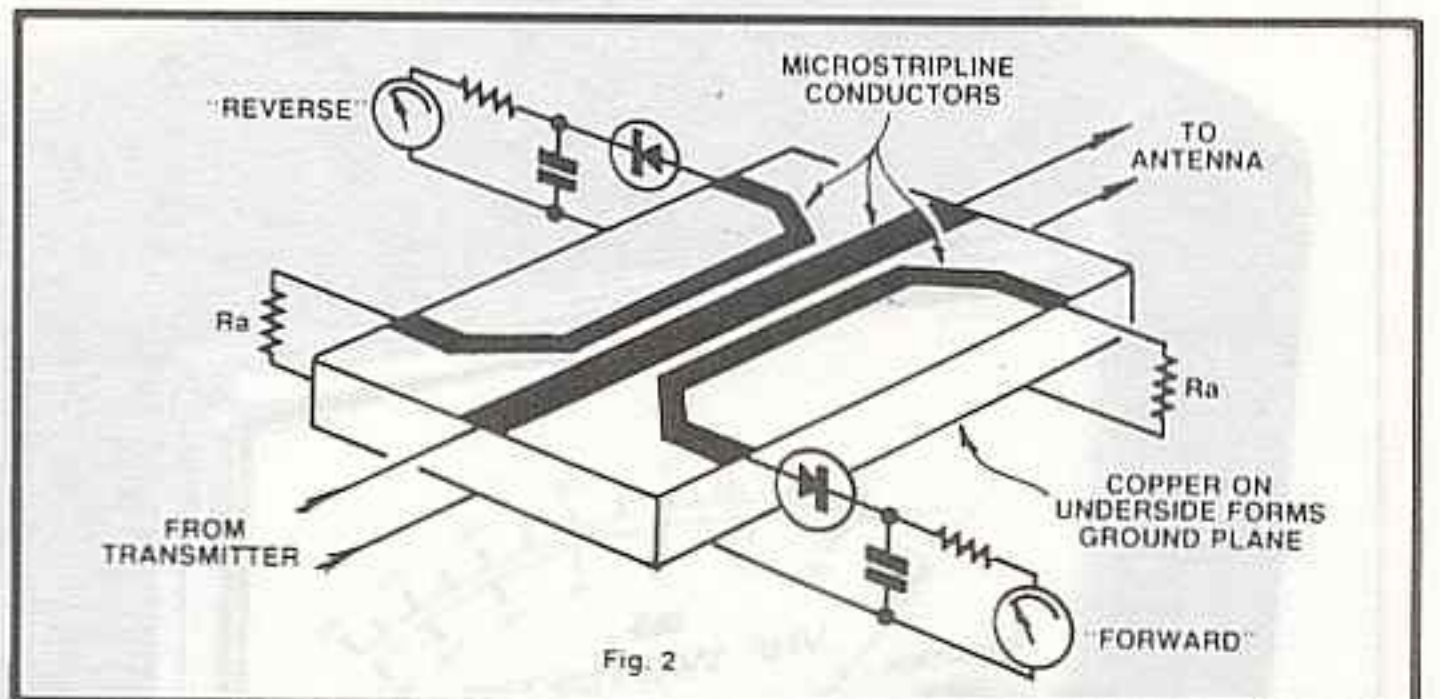

Fig.2: two secondary striplines are required to measure power in both forward and reverse directions.

Specifications

Usable frequency range	144-148MHz
Maximum power	150W
Ranges	0-30W; 0-150W
Accuracy	±10%
Impedance	50Ω
Directivity	>20dB
Insertion loss	<0.1dB

physical arrangement. The microstriplines themselves consist of strips of copper etched on one side of a small PCB, while the unetched copper laminate on the other side of the board forms the ground plane.

It's now only a short step to the final circuit shown in Fig.3. Both the forward and reverse microstriplines are present as in Fig.2, but their outputs are now switched (via S1) to a common meter movement.

The primary microstripline connects to the antenna feedline via two SO239 sockets. The impedance of the primary stripline is 50Ω while the secondary microstriplines have a characteristic impedance of 75Ω and are thus terminated with 75Ω load resistors.

Diodes D1 and D2 are Schottky types which are necessary to ensure good performance at 144MHz. The rectifier outputs are filtered by C1L1 and C2L2 respectively, and applied to S1 via 20kΩ calibration trimpots (VR1 and VR2). S2 selects either the 0-30W or 0-150W ranges while VR3 provides calibration of the 150W range.

Construction

Three small printed circuit boards are used in the VHF Wattmeter assembly. The microstriplines are etched onto a PCB coded ZA1663A (120 x 50mm) and this board also holds the 75Ω resistors, feedthrough capacitors and Schottky diodes. A second board coded ZA1663C (100 x 20mm) accommodates the trimpots and switches.

The third board is coded ZA1663B and measures 74 x 50mm. It consists of a piece of single-sided unetched PCB laminate and serves as a cover plate for the microstripline PCB (ZA1663A).

Begin assembly by installing the resistors and diodes. Note that the bodies of these components fit into four cutout areas and that the leads must be soldered on the top (microstripline side) of the PCB. This done, the two feedthrough capacitors can be mounted.

One lead of each capacitor is soldered directly to the cathode of its corresponding diode while the earth disc is soldered direct to the top of the PCB. The remaining (looped) lead is subsequently used to terminate flying leads.

The next step is to fit ten PC stakes (five at either end) through unused holes in the earth pattern of the PCB (see wiring diagram). These stakes should be soldered to both sides of the board using generous amounts of solder. This step is designed to provide a low-impedance path between the earth pattern on the top of the PCB and the groundplane on the other side.

Construction of the microstripline PCB assembly can now be completed by installing the cover plate PCB. The two boards are fastened together using four 12mm nylon screws and nuts. Note that the copper laminate on the plate

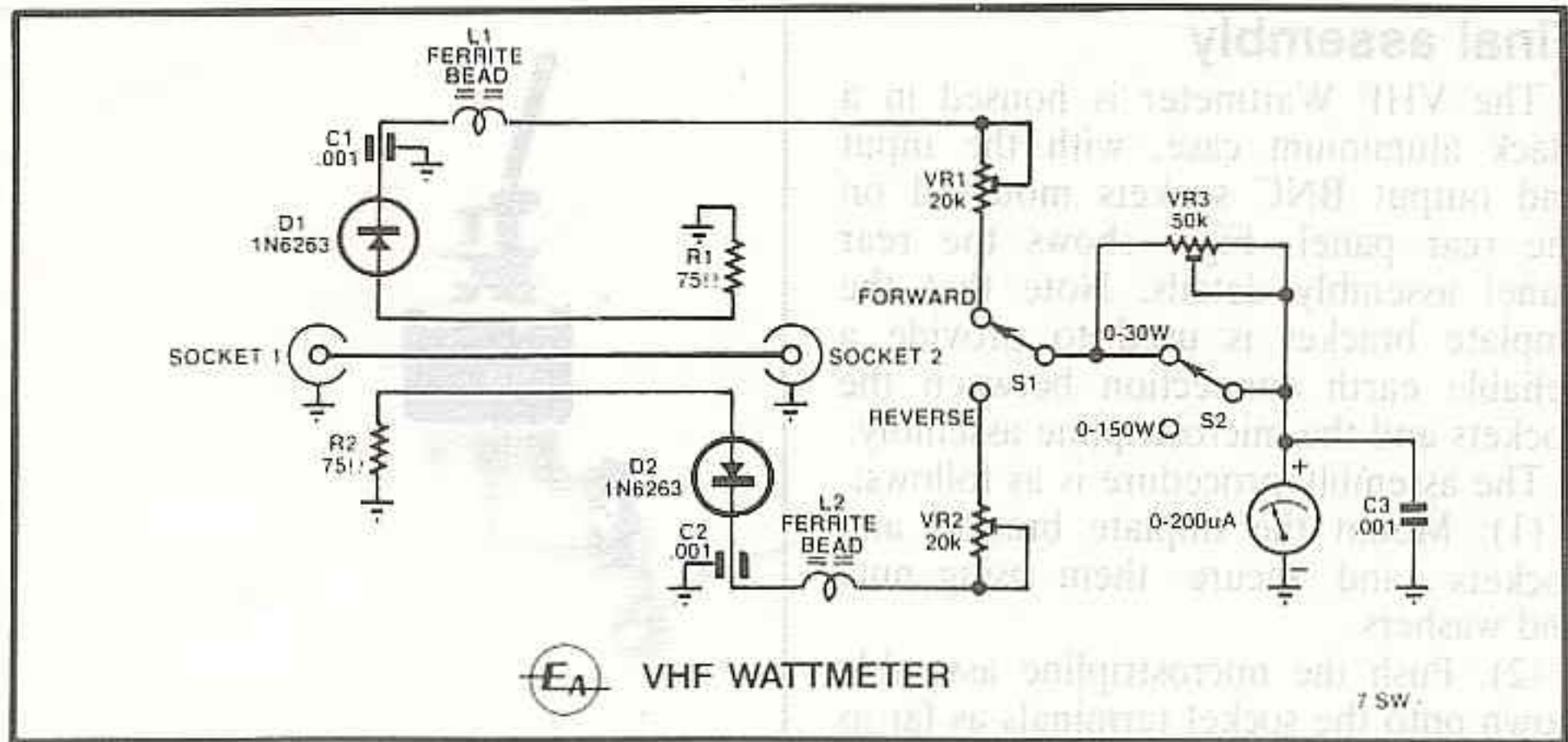
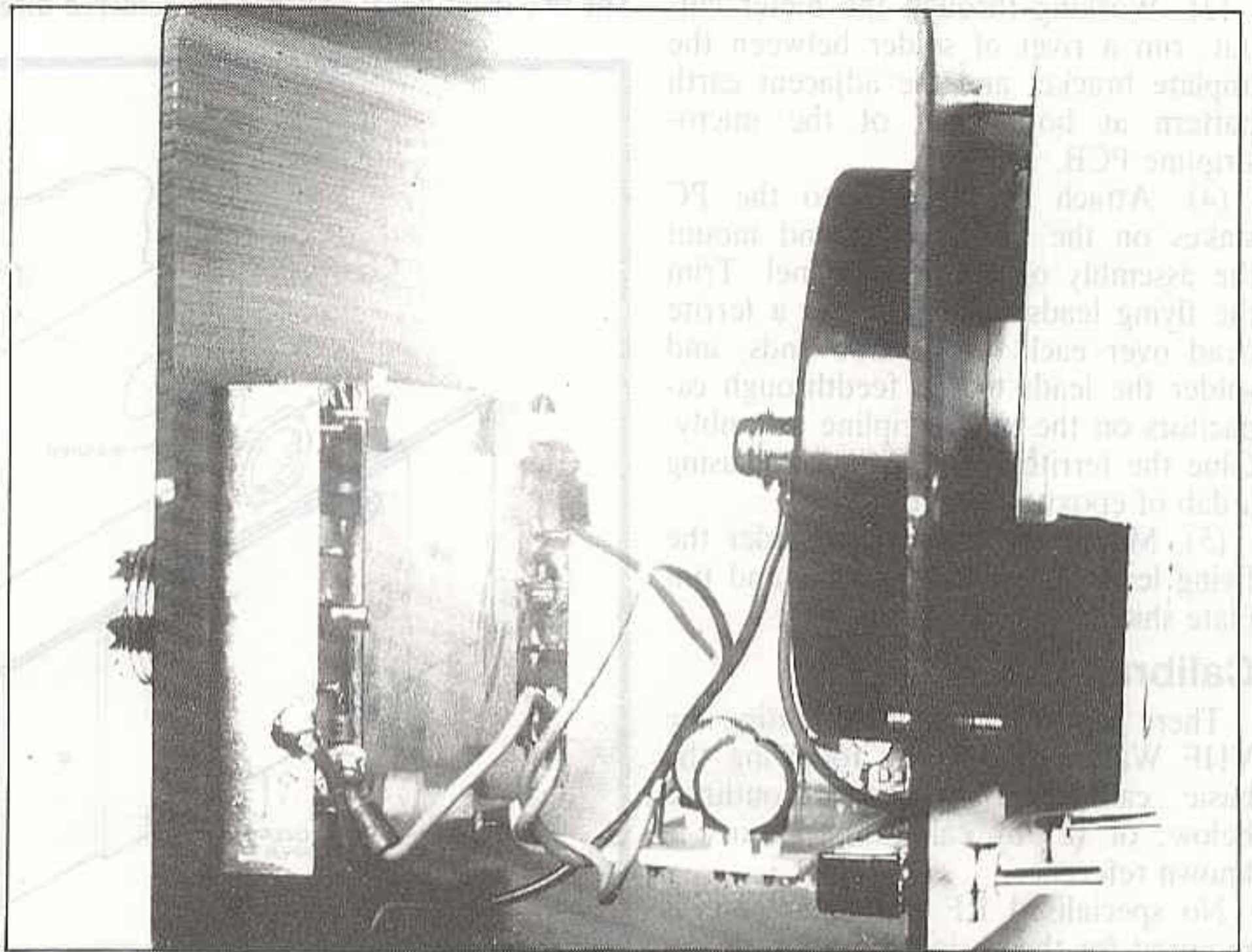
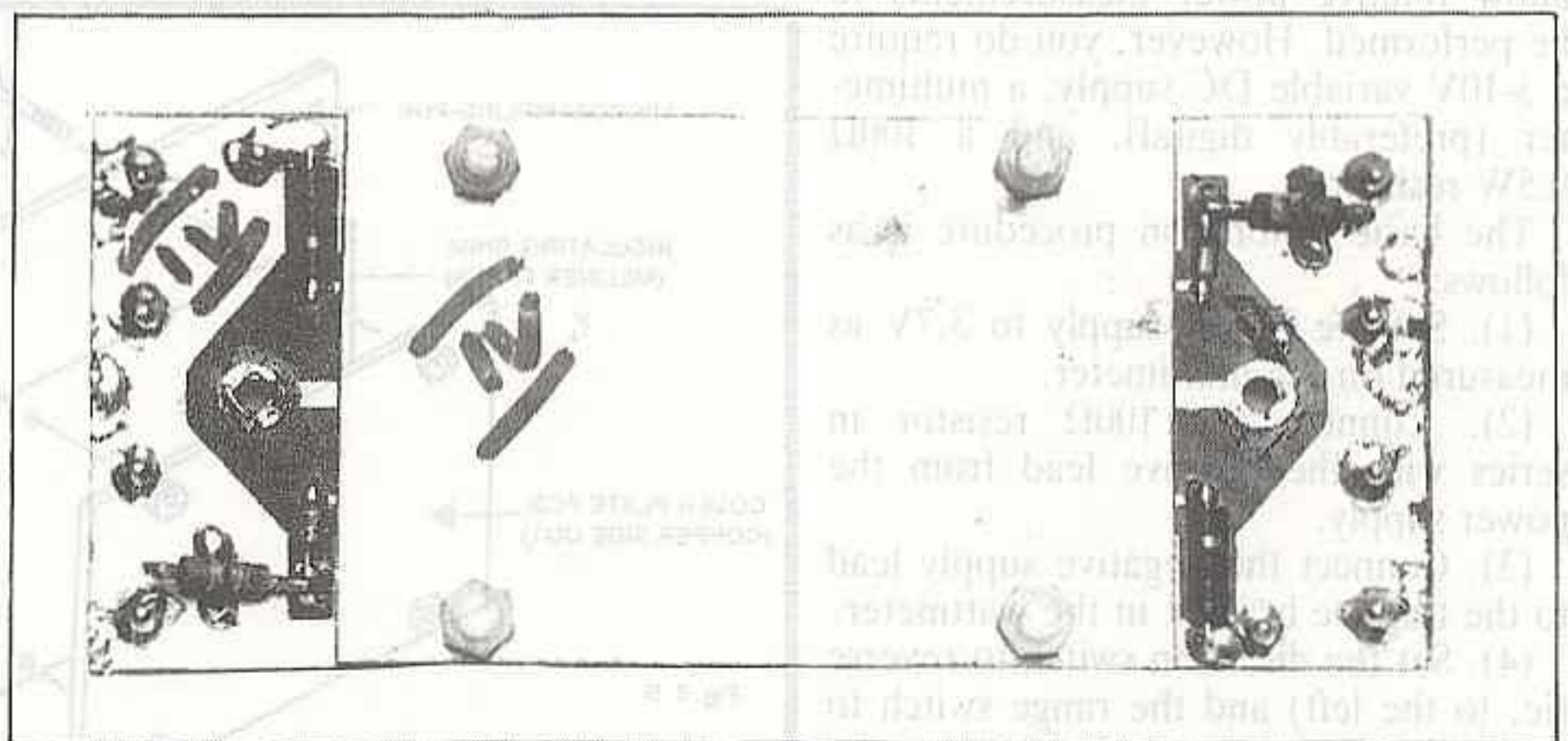

Fig.3: the forward and reverse microstriplines are switched to a common meter.



Above: view inside the completed instrument showing the microstripline assembly.



Above: this view shows the completed microstripline PCB with the cover plate attached.

PCB faces outwards and that the two boards must be separated slightly by installing an insulating shim (Melinex paper, cut to the size of the coverplate PCB) between the microstripline PCB and the coverplate PCB. (see Fig. 5)

Once the microstripline assembly has been completed, attention can be turned to the remaining board. Install PC stakes at the two external wiring

points, then mount the trimpots and switches. Note that the switches are soldered directly to the underside of the PCB.

The remaining component, capacitor C3 (.001µF), is soldered directly across the meter terminals. Install the capacitor as shown in Fig. 4, together with two 70mm-long flying leads.

Final assembly

The VHF Wattmeter is housed in a black aluminium case, with the input and output BNC sockets mounted on the rear panel. Fig.5 shows the rear panel assembly details. Note that the tinplate bracket is used to provide a reliable earth connection between the sockets and the microstripline assembly.

The assembly procedure is as follows:

(1). Mount the tinplate bracket and sockets and secure them using nuts and washers.

(2). Push the microstripline assembly down onto the socket terminals as far as it will go and solder the terminals to the pads.

(3). Working through the meter cut-out, run a rivet of solder between the tinplate bracket and the adjacent earth pattern at both ends of the microstripline PCB.

(4). Attach flying leads to the PC stakes on the switch PCB and mount the assembly on the front panel. Trim the flying leads to length, slip a ferrite bead over each of the free ends, and solder the leads to the feedthrough capacitors on the microstripline assembly. Glue the ferrite beads in position using a dab of epoxy adhesive.

(5). Mount the meter and solder the flying leads to the switch PCB and tinplate shield as shown in Fig.4.

Calibration

There are two ways of calibrating the VHF Wattmeter: (1) by following the basic calibration procedure outlined below; or (2) by calibrating against a known reference.

No specialised RF test equipment is required for the basic calibration procedure which gives sufficient accuracy to allow relative power measurements to be performed. However, you do require a 3-10V variable DC supply, a multimeter (preferably digital), and a 100Ω 0.5W resistor.

The basic calibration procedure is as follows:

(1). Set the power supply to 3.7V as measured on the multimeter.

(2). Connect the 100Ω resistor in series with the positive lead from the power supply.

(3). Connect the negative supply lead to the tinplate bracket in the wattmeter.

(4). Set the direction switch to reverse (ie. to the left) and the range switch to the 30W position, and connect the power supply positive lead (via the 100Ω resistor) to non-earth side of R2.

(5). Adjust trimpot VR2 for full scale deflection on the meter.

(6). Disconnect the supply lead from R2, set the direction switch to forward, and connect the supply lead to the non-earth side of R1.

(7). Adjust trimpot VR1 for full scale deflection.

(8). Set the range switch to the 150W

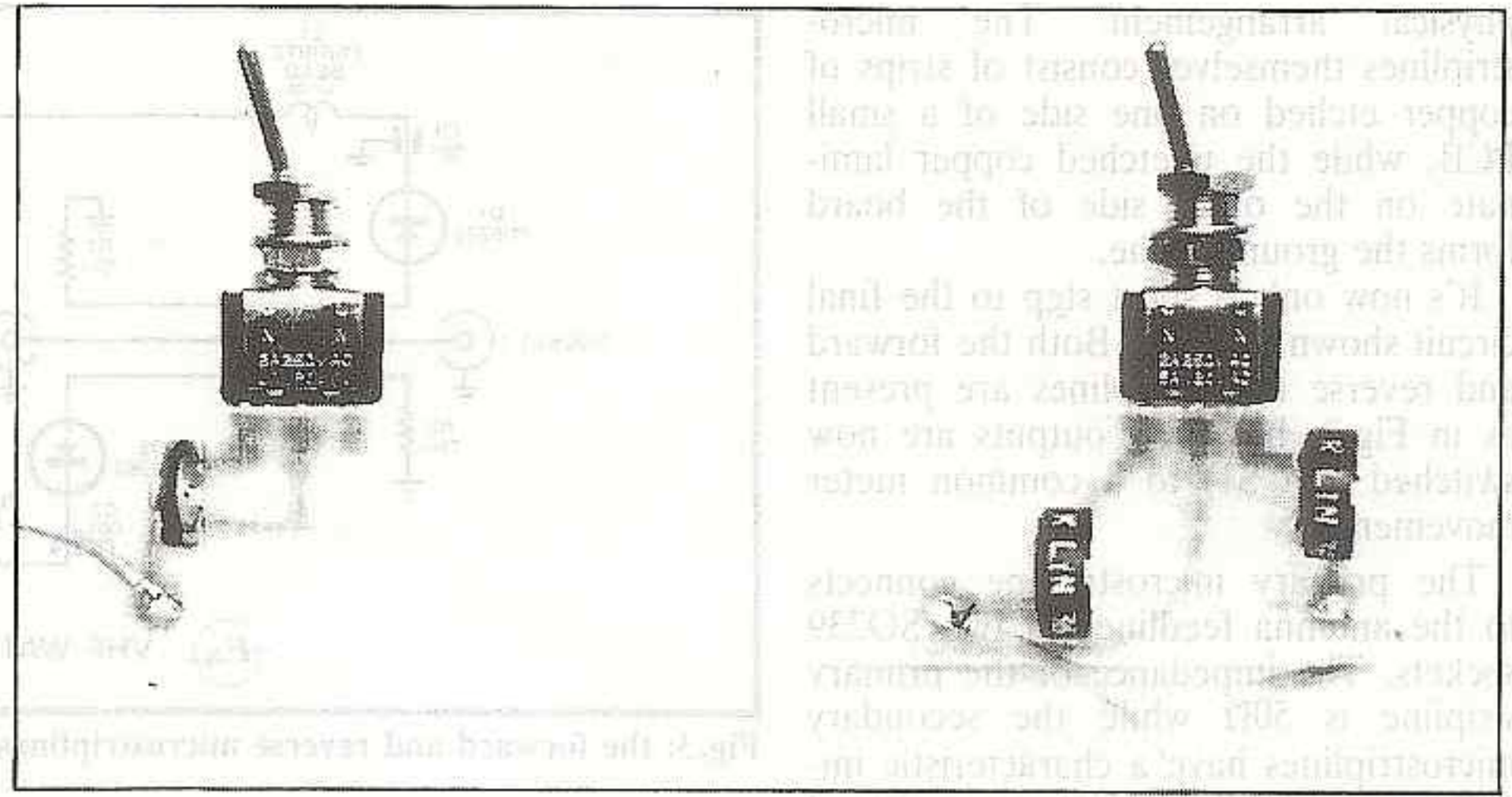

The two front panel switches are soldered directly to the underside of the trimpot PCB.

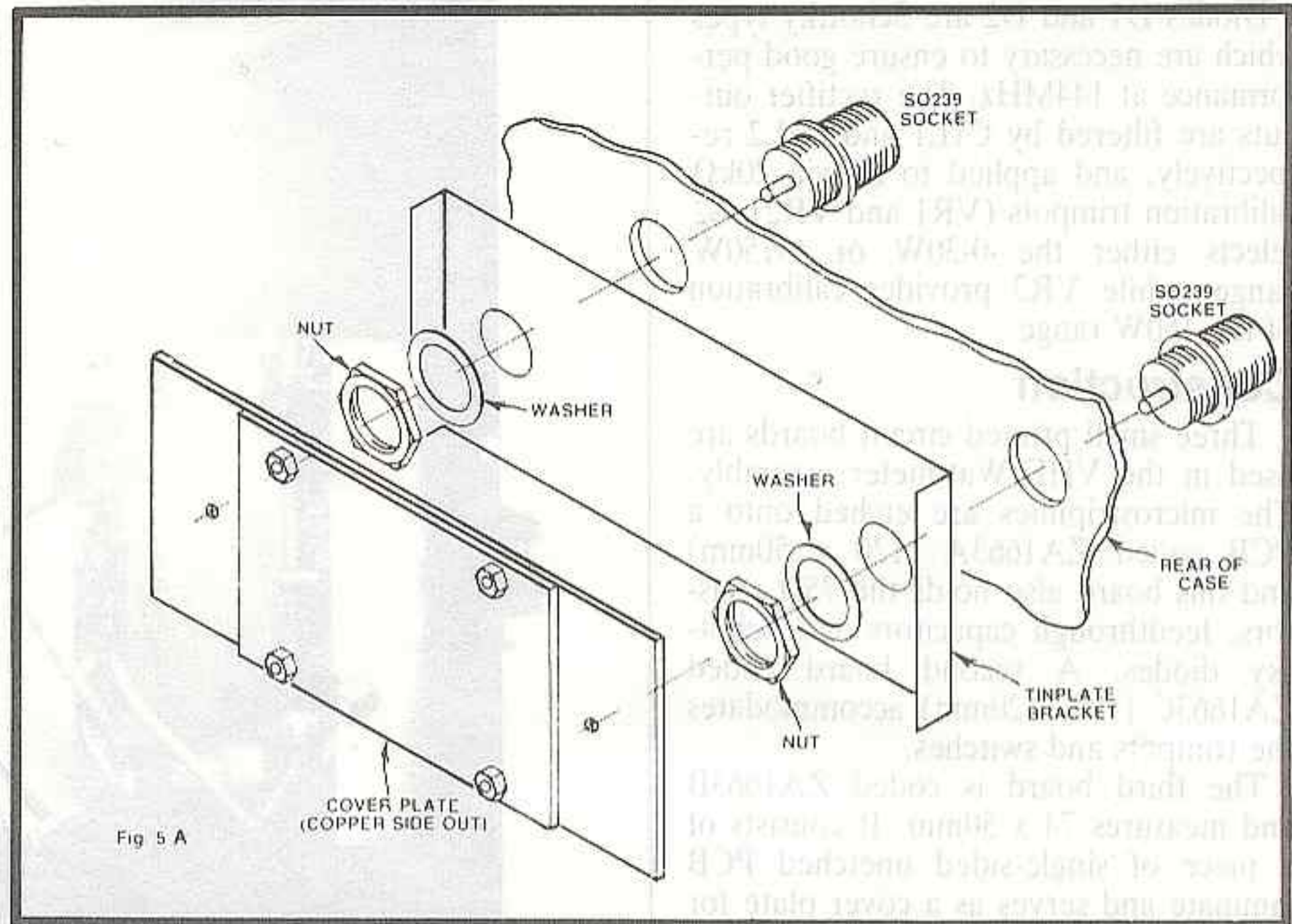
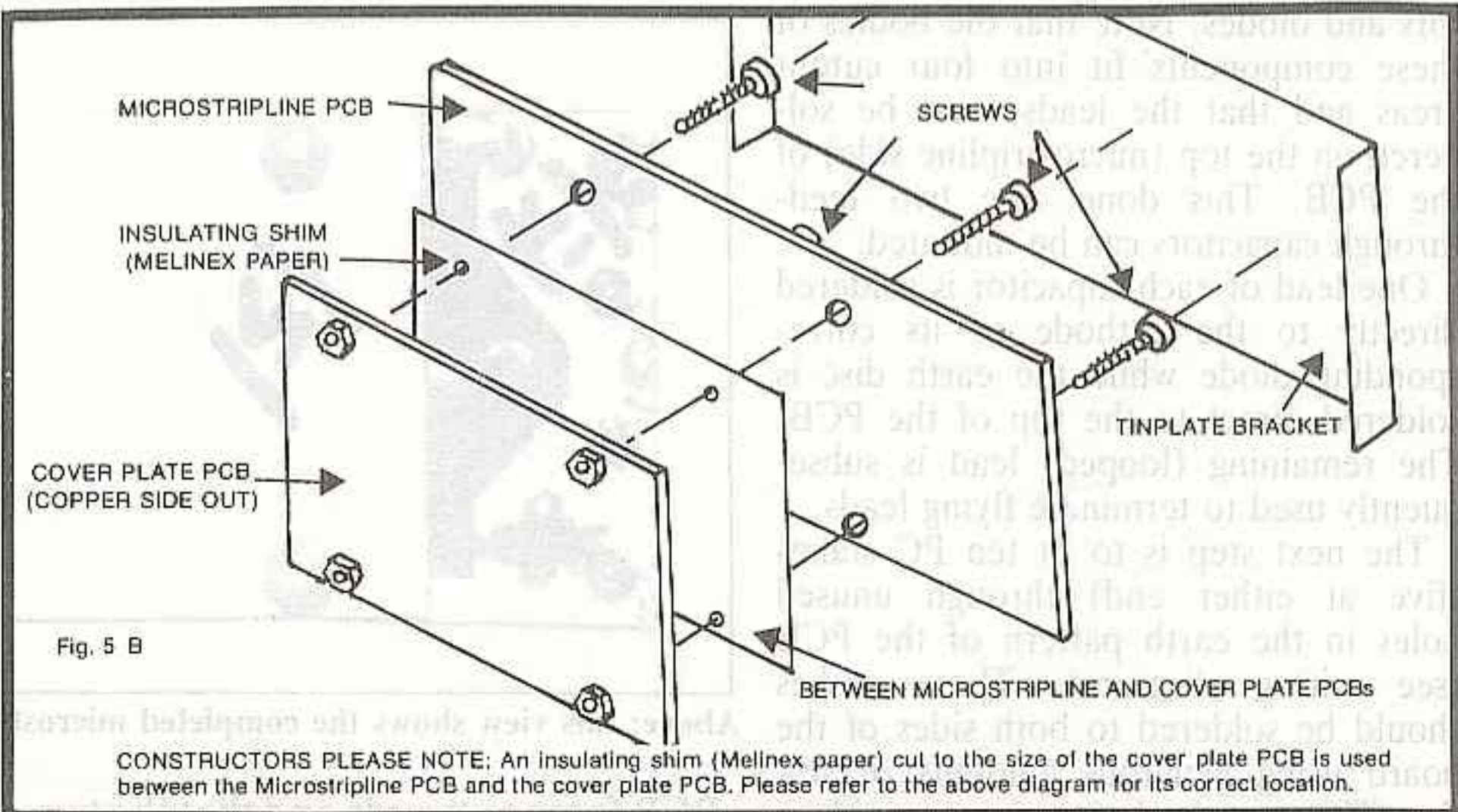

Fig.5: rear panel assembly details. The copper side of the cover plate faces outwards.



CONSTRUCTORS PLEASE NOTE: An insulating shim (Melinex paper) cut to the size of the cover plate PCB is used between the Microstripline PCB and the cover plate PCB. Please refer to the above diagram for its correct location.

position and wind up the power supply to 9V as measured at the supply terminals.

(9). Adjust VR3 for full scale deflection on the meter, then disconnect the lead to R1.

That completes the basic calibration procedure which should give sufficient

accuracy for most uses. Alternatively, if greater overall accuracy is required, Dick Smith Electronics will calibrate your completed wattmeter against a Bird Model 43 Throughline Directional Wattmeter, an industry standard instrument

How to use it

In a practical system, the forward and reflected power components vary along the length of the transmission line due to line losses. This means that the SWR is not constant along the transmission line but reduces progressively as one moves back from the antenna to the transmitter. Not surprisingly, the amount of this reduction depends upon the losses contributed by the line.

Because it is the antenna-feedline match that is of interest, there is only one correct place to make SWR measurements: as close as possible to the antenna end of the feedline. Unless feedline losses are quite small, any measurements taken at the transmitter end will be quite misleading.

An example will serve to illustrate the point. Let's say that transmission line losses are 3dB and that the antenna mismatch is such that the SWR is 2:1. Thus, if 100W is fed up the line, only 50W reaches the antenna due to line losses.

By substituting in equation 1, we find that only 44.4W will be delivered to the antenna while 5.6W will be reflected down the line. And, because of the 3dB line loss, only half this reflected power will reach the transmitter, ie. 2.8W.

Thus, inserting the wattmeter at the transmitter end results in a forward reading of 100W and a reverse reading of 2.8W. If we plug these figures into equation 1, we get a quite acceptable SWR figure of 1.46:1. This is significantly less than the real figure of 2:1, the latter representing a fairly serious

mismatch.

It gets worse as cable losses increase. In the foregoing example, a 6dB line loss would result in a measured SWR at the transmitter end of only 1.18:1, while a seriously mismatched antenna with an SWR of 3:1 (6dB line loss) will still only give an SWR of 1.29:1 at the transmitter.

The message is clear. If you want to make accurate SWR measurements, in-

stall the wattmeter at the antenna end of the feedline.

Finally, in cases of serious mismatch, it will be necessary to make adjustments to the antenna. For example, it may be necessary to employ an antenna tuning unit (ATU), a matching transformer or to make adjustments by one means or another to the antenna itself. The exact approach will vary according to the installation. ●

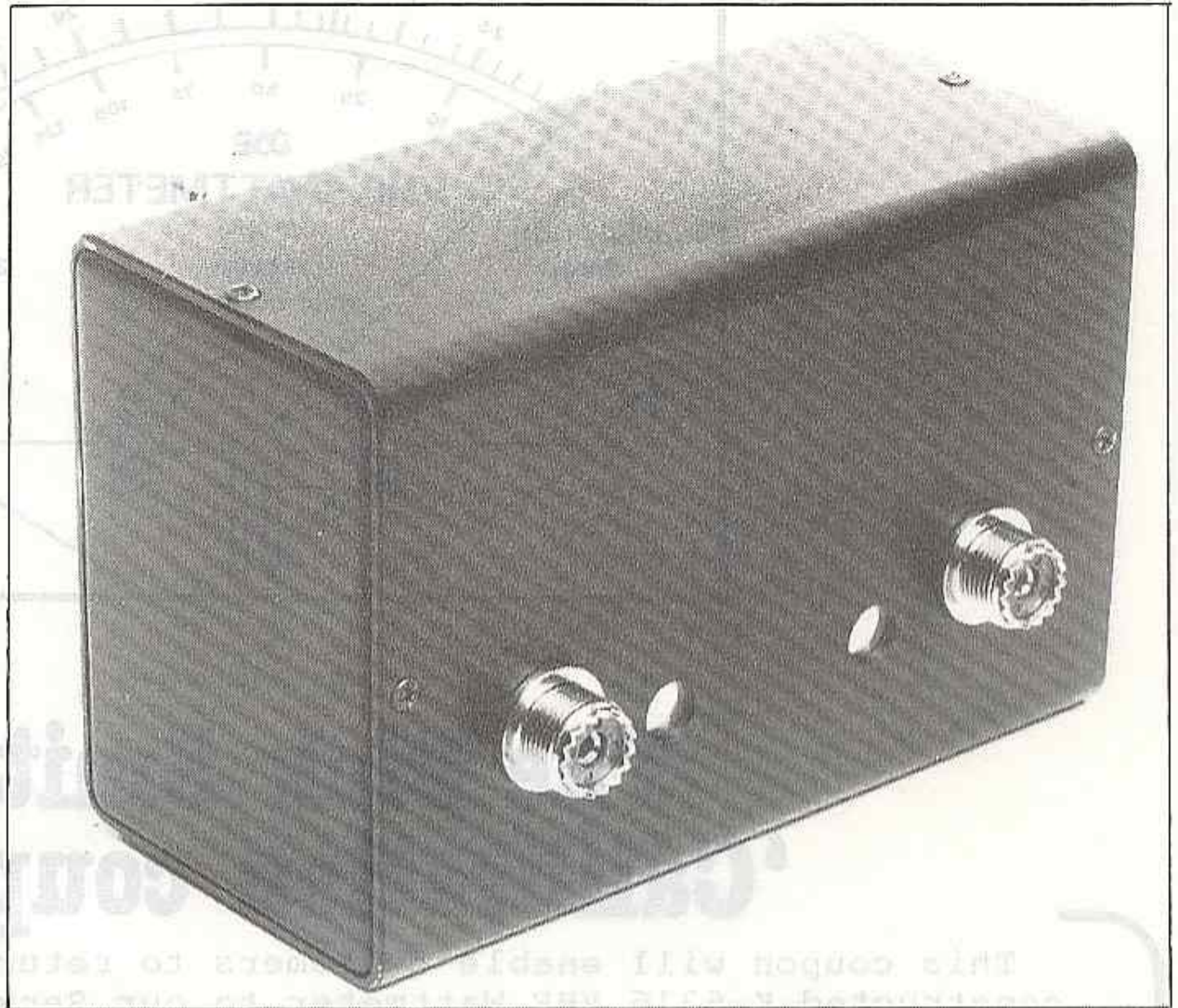

The rear panel accommodates the two SO-239 sockets (socket 1 right; socket 2 left).

PARTS LIST

Resistors

2x 75R Resistors C/Carbon(R1,R2)

Capacitors

2x 1000pF F/Through Cap(C1,C2)

1x 1000pF 50V Ceramic Cap(C3)

Semiconductors

2x 20K/25K Trimpot(VR1,VR2)

1x 47K/50K Trimpot(VR3)

2x HP2800/IN6263 Diode(D1,D2)

Miscellaneous

Ferrite Bead, sockets, toggle switches, screws, nuts, PCB pins, H/U wire, Insulating shim, solder, PCB (set of three), case & ends, panel meter, VHF meter face, tin plate bracket, Power Chart

CHANGING METER PANEL

Unscrew the two phillips-head screws located at either side of the meter panel. Once these screws are removed the meter face will come off with just a little persuasion.

To remove the scale plate, another two small phillips-head screws will have to be removed. These are located either side of the moving coil. Once removed, slide the scale plate away from the meter needle. Care must be taken when changing the panels, as damage may be caused to the coil unless the panels are slid into position. Having attached the new meter face, installation is simply the opposite procedure to the above.

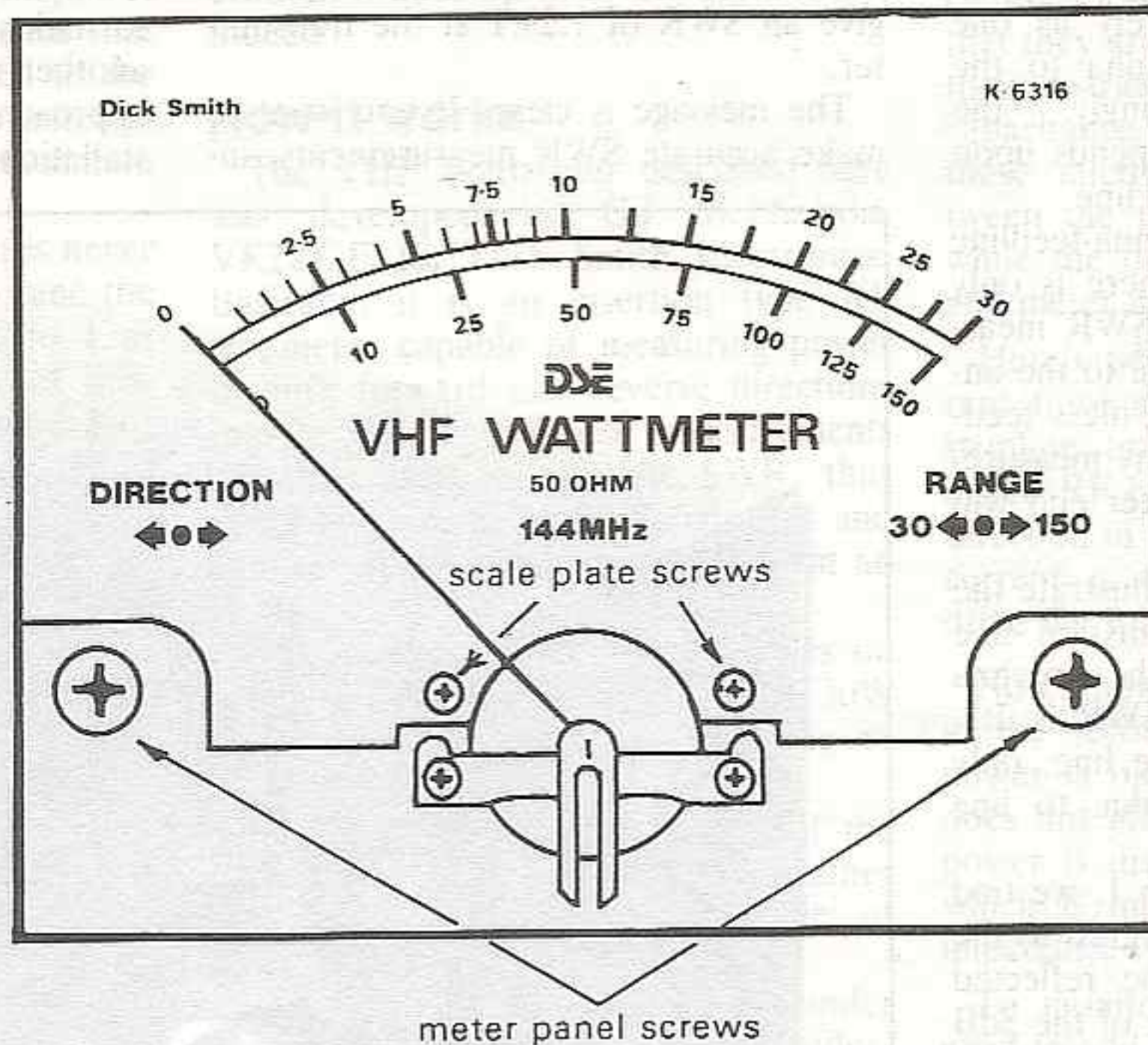

The Dick Smith 'Calibration coupon'

This coupon will enable customers to return their fully constructed K-6316 VHF Wattmeter to our Service Department, together with a calibration of only \$15.00. All kits received must be in working condition and we reserve the right to return faulty kits uncalibrated with the \$15.00.

A Bird Model 43 Throughline RF Directional Watt Meter, with an accuracy of within 5% will be used as the standard.

NAME

ADDRESS

..... POSTCODE PHONE

DATE KIT PURCHASED PURCHASED FROM

I AM A - COMPLETE BEGINNER HOBBYIST EXPERIENCED

I have included the \$ 15.00 calibration fee.

STORE LOCATIONS

HEAD OFFICE & DS XPRESS ORDER SERVICE P.O. Box 321, North Ryde, N.S.W. 2113. Tel (02) 888 3200 AUSTRALIA.

Australia
 Auburn (02) 83 8399
 Bankstown (02) 707 4000
 Blacktown (02) 671 7722
 Biala (02) 544 7744
 Bondi Junction (02) 307 1444
 Brookvale (02) 53 0441
 Campbelltown (046) 27 2199
 Cherrywood Chase (02) 411 1955
 Chullora (02) 642 8922
 Gore Hill (02) 439 5311
 Gosford (043) 25 0235
 Hornsby (02) 477 6633
 Liverpool (02) 600 9888
 Maitland (049) 33 7866
 Miranda (02) 784
 Newcastle (049) 61 1896
 North Ryde (02) 88 3855
 Parramatta (02) 689 2188
 Penrith (047) 32 3420
 Railway Square (02) 211 3777
 Sydney City (02) 267 9111
 Tamworth (067) 66 1711
 Wallingong (042) 28 3800
 ACT
 Canberra (06) 80 4944

NSW
 Ballarat (053) 34 5633
 Bendigo (024) 43 0358
 Box Hill (03) 890 0899
 East Brighton (03) 592 2366
 Coburg (03) 383 4455
 Eastwood (03) 379 7444
 Frankston (03) 783 5444
 Geelong (062) 43 8822
 Melbourne City (03) 87 9834
 Richmond (03) 428 1614
 Springvale (03) 547 0522
QLD
 Brisbane City (07) 229 9377
 Buranda (07) 391 6333
 Chermside (07) 355 0255
 Rockhampton (079) 27 9644
 Southport (079) 32 9866
 Toowoomba (074) 38 4300
 Townsville (077) 72 5722
 Underwood (07) 341 0844
SA
 Adelaide (08) 212 1962
 Darwin (08) 298 8777
 Enfield (08) 230 6088
 Salisbury (08) 241 1593
WA
 Perth (08) 451 8666

VIC
 Melbourne (03) 941 1111
 Melbourne (03) 941 1111
 Melbourne (03) 941 1111
 Melbourne (03) 941 1111
NT
 Darwin (08) 298 8777
 Darwin (08) 298 8777
 Darwin (08) 298 8777
 Darwin (08) 298 8777

NT
 Darwin (08) 298 8777
 Darwin (08) 298 8777
 Darwin (08) 298 8777
 Darwin (08) 298 8777

NT
 Darwin (08) 298 8777
 Darwin (08) 298 8777
 Darwin (08) 298 8777
 Darwin (08) 298 8777

NT
 Darwin (08) 298 8777
 Darwin (08) 298 8777
 Darwin (08) 298 8777
 Darwin (08) 298 8777

NT
 Darwin (08) 298 8777
 Darwin (08) 298 8777
 Darwin (08) 298 8777
 Darwin (08) 298 8777

NT
 Darwin (08) 298 8777
 Darwin (08) 298 8777
 Darwin (08) 298 8777
 Darwin (08) 298 8777

NT
 Darwin (08) 298 8777
 Darwin (08) 298 8777
 Darwin (08) 298 8777
 Darwin (08) 298 8777

