

# Assembly Manual

## Insulation Tester

## K-7002

Reproduced in part by arrangement with Silicon Chip, from their May 1996 edition.

Please read Disclaimer carefully as we can only guarantee parts and not the labour content you provide.



*This high-voltage insulation tester can measure resistance from 1-2200 gigaohms. It is battery powered and displays the readout on a 10-step LED bargraph type display.*

In all cases, when ever mains-operated equipment has been built or repaired, it is wise to test the insulation resistance between active and neutral to earth. This will verify that there is no leakage path to earth which could lead to a serious breakdown later on or pose a hazard to the user if the earth connection fails.

Of course, a multimeter set to the high ohms range can often detect insulation problems but this is not always a valid test. That's because a multimeter only produces a very low value test voltage (around 1.5V) and many types of insulation breakdown occur at much higher voltages.

Another problem with a normal multimeter is that it will only show overrange for "good" insulation measurements rather than the actual value of the resistance. This is because insulation resistance measurements usually result in readings of thousands of megohms (ie, gigaohms - GΩ) rather than the nominal 20MΩ maximum value for a multimeter.

The Insulation Tester described here is a self-contained meter which will measure very high values of leakage resistance for a number of test voltages. It will also test capacitors for leakage. A 10-LED bargraph display is used to indicate the leakage resistance. A test voltage switch selects between five

possible values, while a 3-position range switch selects either x1, x10 or x100 scale readings.

### Block diagram

Fig.1 shows the block diagram of the Insulation Tester. It is based on a high voltage supply, produced by stepping up from a 9V battery using a converter. This converter can produce either 100V, 250V, 500V, 600V or 1000V DC.

Note that, because of the high voltages involved, a safety resistor is included in series with the output. This limits the output current to a minuscule level to (a) protect the circuit when the probes are short circuit; and (b) prevent the user from receiving a nasty electric shock.

In operation, the leakage of the insulation under test causes a current to flow between the test terminals. This current is then monitored by the detector resistance between the negative test terminal to ground. The higher the leakage current, the higher the voltage across the detector resistance.

This voltage is measured using a special voltmeter circuit which is calibrated to show the resistance on a LED bargraph readout. This is no ordinary meter since it cannot divert any significant current away from the detector resistance or false readings will occur. And the currents involved are extremely minute.

A simple calculation will tell us exactly how small the currents flowing between the test terminals are. Assuming a 1000V test voltage and a 2000MΩ

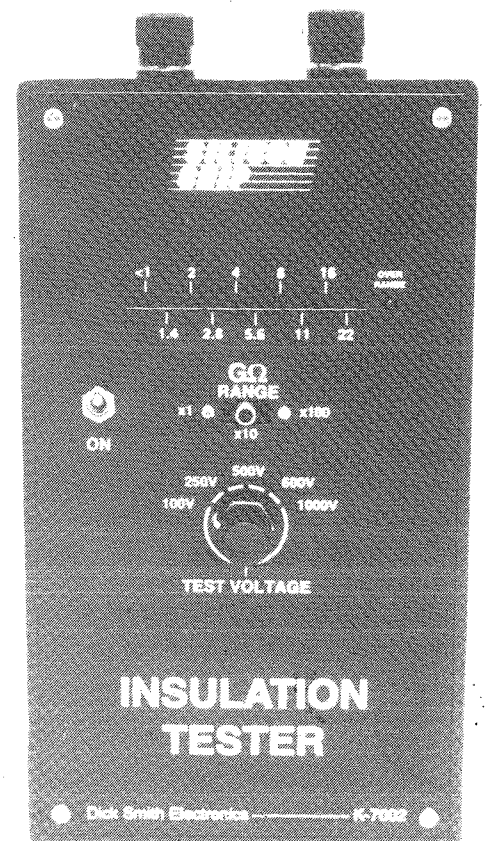

*The prototype Insulation Tester was built into a standard plastic case.*

## Features

- LED bargraph display
- Five test voltages from 100-1000V
- Measures from 1GΩ (1000MΩ) to 2200GΩ (2.2TΩ)
- Battery operated
- Overrange indication

(2GΩ) resistance between the test terminals, the current flow will be just  $1000/(2 \times 10^9) = 500\text{nA}$ . The same resistance at a test voltage of 100V will allow only 50nA to flow.

At 2200GΩ (the upper measurement limit of the Insulation Tester), the current flow is a minuscule 45pA ( $45 \times 10^{-12}$ ) when 100V is applied. As a consequence, we need to measure the voltage across the detector resistor without drawing any more than a few picoamps (pA).

## Circuit details

Fig.2 shows the full circuit of the Insulation Tester. It uses six ICs, a transformer, Mosfet Q1 and a number of minor components.

The step-up converter uses the two windings of transformer T1 to produce up to 1000VDC. When Mosfet transistor (Q1) is switched on, it charges the primary winding via the 9V supply. When Q1 is switched off, the charge is transferred to the secondary and delivered to a .0033μF 3kV capacitor via series diodes D1-D3. These three diodes are rated at 500V each and so together provide more than the required 1000V breakdown.

Following the .0033μF capacitor, the stepped-up voltage is filtered using a 4.7MΩ resistor and a 470pF capacitor. It is then fed to the positive test terminal via a second 4.7MΩ resistor. Note that these two 4.7MΩ resistors provide the current limiting function referred to earlier.

Q1 is driven by an oscillator formed by TLC555 timer IC2. (During constructing and testing our prototype, we found that the kit only worked well with a TLC555 CMOS timer. ICM7555 and LMC555CN were found to cause problems in the kits operation). This operates by successively charging and discharging a .0018μF timing capacitor (on pins 2 & 6) via a 6.8kΩ resistor connected to the output (pin 3). Let's take a closer look at how this works.

When power is first applied, the capacitor is discharged and the pin 3 output is high. The timing capacitor then

## Specifications

Test voltages.....	100, 250, 500, 600 & 1000V
Test voltage accuracy.....	<5%
Charging impedance.....	9.4MΩ
Current drain 50mA.....	@ 1000V out

charges to the threshold voltage at pin 6, at which point pin 3 switches low and the capacitor discharges to the lower threshold voltage at pin 2. Pin 3 then switches high again and so this process is repeated indefinitely while ever power is applied.

The voltage at the output of the converter is controlled by monitoring the voltage across a resistor selected by S2b and feeding this to an error amplifier. In greater detail, S2b selects one of five range-setting resistors. This, in conjunction with two associated 4.7MΩ resistors, forms a voltage divider across the converter output.

The voltage divider output is applied to error amplifier IC1a via a 10kΩ resistor. This stage is cascaded with IC1b for high gain. IC1b's output, in turn, drives the threshold pin (pin 5) of IC2.

If the output voltage goes too high, IC1b pulls pin 5 of IC2 slightly lower so that the pulse width duty cycle to Q1 is reduced. This in turn lowers the output voltage. Conversely, if the output voltage is too low, IC1b pulls pin 5 of IC2 higher. This then increases the duty cycle of the drive to Q1 and so the output voltage also increases.

Basically, IC1a compares the voltage divider output with a fixed reference voltage applied to its pin 3. This reference voltage is provided by IC3a and IC3b. IC3a is part of an LM10 dual op amp which includes a 200mV fixed reference at its non-inverting input (pin 3). It amplifies this reference by a factor of 10 to provide 2V at its pin 1 output.

IC3b is connected as a unity gain

buffer and provides a low impedance output for the 2V reference. Note that the reference voltage is taken from the inverting input at pin 2, while the output at pin 6 drives pin 2 via a 100Ω resistor. This resistor isolates IC3b's output from the associated 100μF decoupling capacitor.

IC4, a CA3140E FET-input op amp, functions as a buffer stage and is used to monitor the voltage across the detector resistor. This op amp offers a very high input impedance of 1TΩ (1000GΩ) and a nominal 2pA input current at the 9V supply. However, this input impedance and current is only valid if there is no leakage on the PC board.

To prevent board leakage we have added a guard track around the input which is at the same voltage as pin 3. This effectively prevents current flow from the negative test terminal to other parts of the circuit.

Trimpot VR1 (between pins 1 & 5) is used to adjust the offset voltage at the output (pin 6) of IC4, while S2a sets the gain. This varies from x10 in the 1000V position up to x100 for the 100V setting. These gain adjustments are necessary to compensate for the voltage change that occurs across the detector resistance each time the test voltage is changed.

The 100kΩ input resistor at pin 3 of IC4 protects the input from damage if the test terminals are shorted, even at the 1000V setting.

Switch S3 selects one of three possible resistance values for the separate ranges. Position 1 selects a 128.2kΩ resistance (120kΩ + 8.2kΩ),

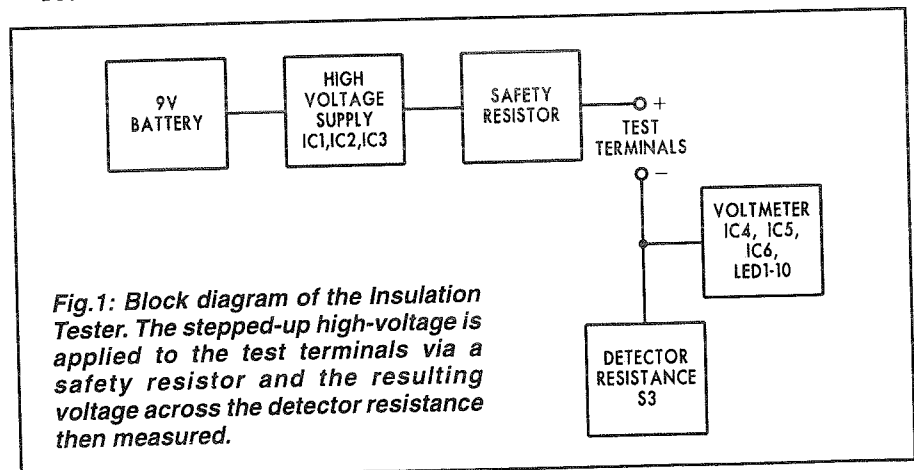

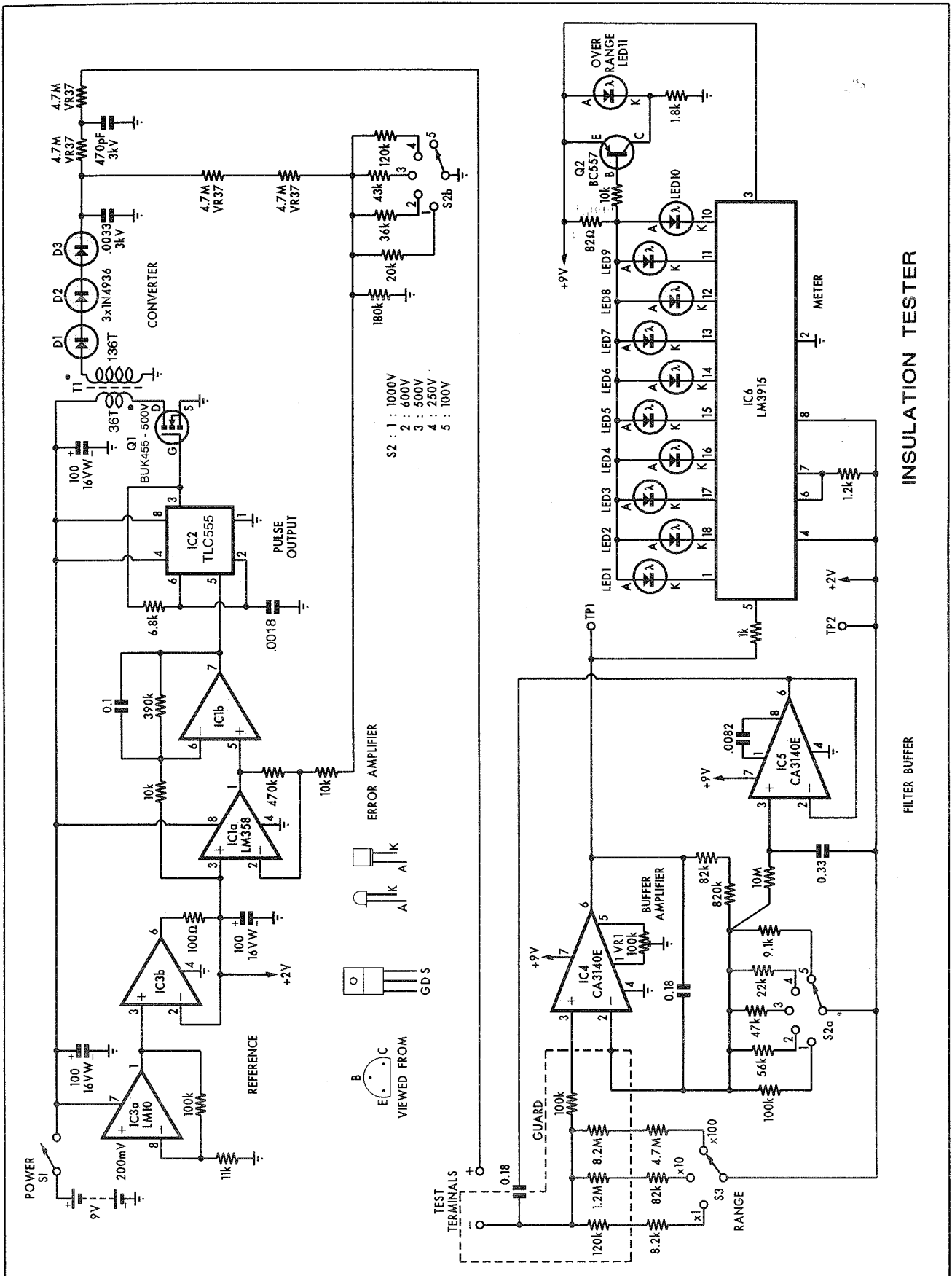

INSULATION TESTER

FILTER BUFFER

Fig.2: The circuit uses a step-up converter based on the IC1a, IC1b, IC2 and Q1 to produce test voltages ranging from 100-1000V.

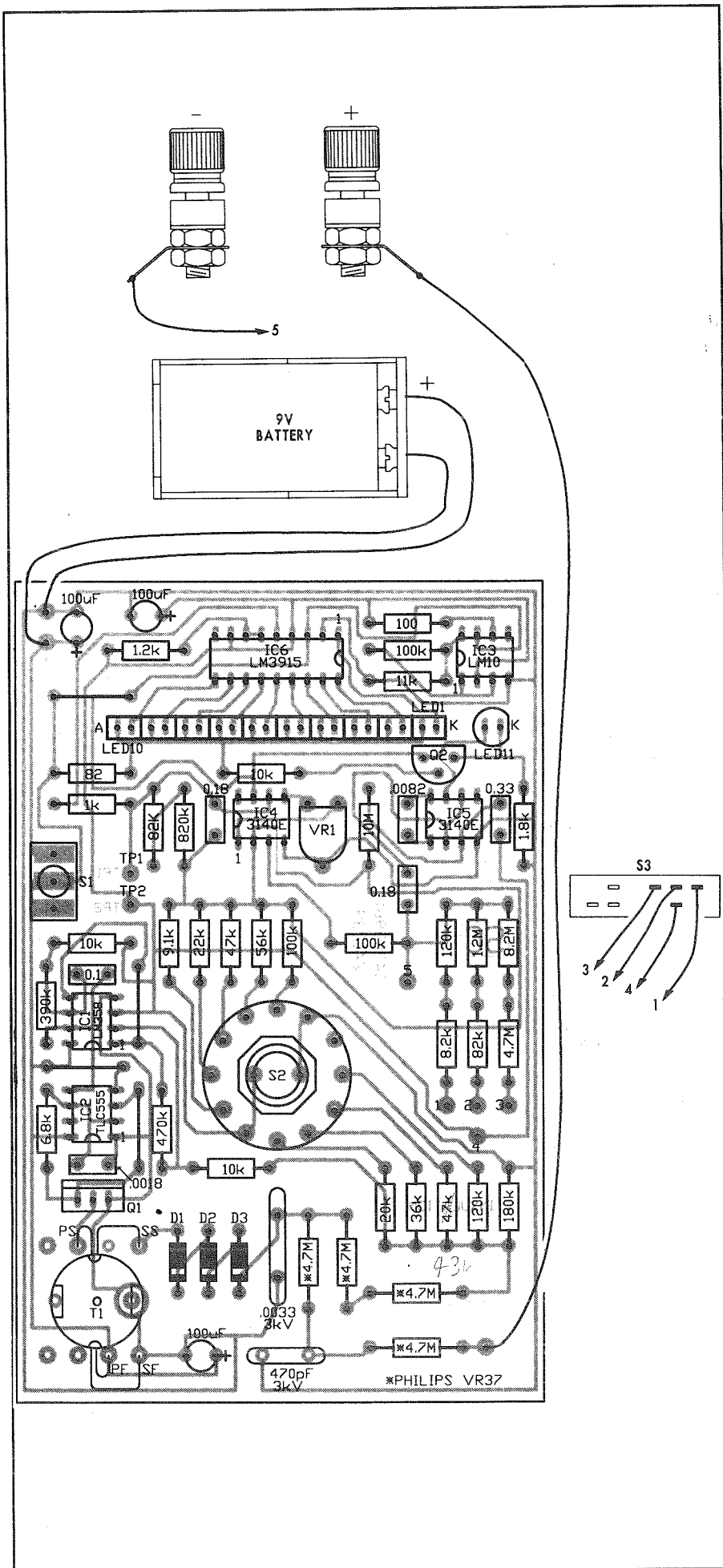

**Fig.3: Install the parts on the PC board exactly as shown on this wiring diagram. Check that the LED display is correctly oriented and be sure to use Philips VR37 resistors where specified.**

position 2 selects 1.282MΩ and position 3 selects 12.82kΩ. These are unusual values but are necessary to correspond to a 1.28V full scale reading for the LED bargraph driver (IC6).

Because of the high impedance at the negative test terminal, the input is prone to hum pickup and so it is filtered using a 0.18µF capacitor. Note that the earthy side of this capacitor is connected to the output of IC5 rather than to ground or to the 2V rail. This arrangement ensures that there is no DC voltage across the capacitor, thus giving the filter a fast response time.

Conversely, if DC voltage had been allowed to appear across the capacitor, the circuit would have taken a considerable time to settle each time a measurement was taken.

Buffer stage IC5 (another CA3140) monitors IC4's pin 2 voltage via a 10MΩ resistor and a 0.33µF capacitor. The output from IC5 at pin 6 is thus a replica of the signal on pin 3 of IC4. It is connected to the earthy side of the 0.18µF filter capacitor, as mentioned above.

Note that IC5 has been given a slow response by connecting a .0082µF compensation capacitor between pins 1 and 8.

IC4's output is applied (via a 1kΩ resistor) to the pin 5 signal input of IC6. This is a logarithmic LED bargraph display driver which switches on LEDs 1-10 in the dot mode. Each step in the bargraph is 3dB (1.41) apart, giving a total 30dB range.

Note that the lower threshold (RLO - pin 4) of IC6 sits at the +2V reference level provided by IC3b. This means that the upper threshold (RHI - pin 6) sits at 3.28V, since this pin sits 1.28V above RLO as set by an internal regulator. This 1.28V difference between RLO and RHI sets the maximum display sensitivity. The 1.2kΩ resistor on pin 7 sets the LED brightness.

Q2 and LED11 provide the overrange indication. If any of the LEDs is on, Q2 is biased on due to the current flowing through the 82Ω resistor. As a result, LED11 is off since Q2 effectively shorts it out.

Conversely, if all the LEDs are out (which equates to a very high resistance), Q2 is biased off and so LED11 now lights to indicate an overrange.

Power for the circuit is derived from a 9V battery (not supplied) via switch S1. There are several 100µF capacitors

## Errata - K 7002 Insulation Tester - Suit Edition 1 & 1A Instructions

The following corrections will need to be made to your instruction manuals. Note, some instruction manuals may already be altered so please ignore.

### 1. Battery Connection

The polarity shown in the component overlay is incorrect. Please terminate the battery snap so that the red (+ve) lead is soldered to the pad adjacent to the +ve side of the 100uF capacitor located in the top left hand corner of overlay (Page 4).

### 2. Transformer - T1

The number of primary windings should be 36 turns and not 40 turns as shown in the circuit and overlay.

### 3. Resistor Change

The 47K resistor (located nearest to bottom right hand corner) adjacent to the 36K and 120K ohm resistor should be 43K. Please note that this is only incorrect in the component overlay and that the circuit diagram is correct.

Dick Smith Electronics apologizes for any inconvenience that may be caused by the above changes.

## Parts List

1 PC board, code ZA1239 (04303961), 86 x 134mm	4 small stick-on rubber feet	1 .0082μF/8n2/822 MKT polyester
1 pre-punched, silk screened front panel	10 PC stakes	1 .0018μF/ 1n8/182 MKT polyester
1 piece of red translucent plastic film	1 100kΩ horizontal trimpot (VR1)	1 .0033μF/3n3/332 3kV ceramic
1 plastic case, 196 x 113 x 60mm	<b>Semiconductors</b>	1 470pF471 3kV ceramic
1 SPDT toggle switch (S1)	1 LM358 dual op amp (IC1)	<b>Resistors (0.25W 1% unless specified)</b>
1 2-pole 6-position rotary PC board mounting switch (S2)	1 TLC555 (type only) CMOS timer (IC2)	1 10MΩ 5% 1 3kΩ
1 2-pole 3-position slider switch plus screws (S3)	1 LM10CLN op amp and reference (IC3)	1 8.2MΩ 5% 1 22kΩ
1 red banana panel mount socket	2 CA3140E Mosfet input op amps (IC4,IC5)	1 4.7MΩ 5% 1 20kΩ
1 black banana panel mount socket	1 LM3915 log bargraph driver (IC6)	4 4.7MΩ Philips VR37
1 test lead set (see text)	1 IRF820, BUZ74 or BUK455-500A 500V N-channel Mosfet (Q1)	1 1.2MΩ 5% 1 11kΩ
1 battery holder and mounting screws	1 BC557 PNP transistor (Q2)	1 820kΩ 1 9.1kΩ
1 2.6uH pot cored transformer (T1)	10 2 x 5mm rectangular red LEDs (LED1-LED10)	1 390kΩ 1 8.2kΩ
1 150mm length of rainbow cable hookup wire	1 3mm red LED (LED11)	1 180kΩ 1 6.8kΩ
1 400mm length of mains-rated wire	3 1N4936 fast recovery diodes (D1-D3)	2 120kΩ 1 1.8kΩ
1 2.1metre length of 0.25mm ENCW copper wire	<b>Capacitors</b>	3 100kΩ 1 1.2kΩ
1 100mm length of 0.8mm tinned copper wire	3 100μF 16/25VW PC electrolytic	2 82kΩ 1 1kΩ
1 length of solder	1 0.33μF/330n/334 MKT polyester	1 56kΩ 1 100Ω
1 20mm knob	2 0.18μF/180n/184 MKT polyester	1 47kΩ 1 82Ω
	1 0.1μF/100n/104 MKT polyester	1 43kΩ

across the supply and these are used to decouple the 9V rail.

### Construction

Most of the circuitry for the Insulation Tester is mounted on a PC board coded ZA1239 (04303961) and measuring 86 x 134mm.

Fig.3 shows the parts layout on the PC board. Begin the assembly by installing PC stakes at the external wiring points (10 in all). These are located at the (+) and (-) battery wiring points, the wiring points for S3 (1-4) and at the (+) and (-) terminal points.

Once the PC stakes are in, install the resistors, diodes and ICs. Don't just rely on the resistor colour codes - check each resistor using a digital multimeter, as some colours can be difficult to read. Take care to ensure that the semiconductors are correctly oriented.

The capacitors can go in next, followed by the transistors and the trimpot (VR1). Note that Q1 must be mounted at full lead length so that it can be bent horizontally over the adjacent .0018μF capacitor. This is necessary to allow clearance for the lid of the case, when it is later installed.

LEDs 1-10 and LED11 can now be installed. Be sure to install the LEDs 1-10 with its anode (A) adjacent to the 82Ω resistor. They should be mounted so that the top surface of the LEDs are 15mm above the board, so that it will later just sit below a matching slot cut into the lid of the case. The top of LED11 should be 20mm above the board surface.

Switch S1 is soldered directly to the PC board. S2 is also installed directly on the PC board.

### Transformer winding

The transformer is supplied with the secondary pre-wound at 136 turns of 0.25mm enamelled copper wire. All that is required is that the primary at 36 turns of 0.25mm enamelled copper wire is wound onto the existing winding and former - see Fig.4.

First you will need to get to the pre-wound former by carefully removing the core clips and pot cores. Then starting at the same side as secondary start (pre-wound) wire, wind on the 40 turns. Place a layer of

insulation tape (not supplied), cut to size to hold down the windings. (Note you will need to be careful that the windings do not exceed the size of the former as you will not be able to fit the pot cores on later). Trim the primary ends to the same lengths of the secondary pre-wound windings and then remove about 5mm of the enamel from the copper wire and tin with some solder.

The transformer can now be re-assembled into its pot cores and clip.

This done, insert the transformer into the PC board, making sure that it is

### Resistor Colour Codes

Value	4-Band (1% or 5% were stated)	5-band (1%)
82Ω	gry-red-blk-brn	gry-red-blk-gld-brn
100Ω	brn-blk-brn-brn	brn-blk-blk-blk-brn
1kΩ	brn-blk-red-brn	brn-blk-blk-brn-brn
1.2kΩ	brn-red-red-brn	brn-red-blk-brn-brn
1.8kΩ	brn-gry-red-brn	brn-wht-blk-brn-brn
6.8kΩ	blu-gry-red-brn	blu-gry-blk-brn-brn
8.2kΩ	gry-red-red-brn	gry-red-blk-brn-brn
9.1kΩ	wht-brn-red-brn	wht-brn-blk-brn-brn
10kΩ	brn-blk-org-brn	brn-blk-blk-red-brn
11kΩ	brn-brn-org-brn	brn-brn-blk-red-brn
20kΩ	red-blk-org-brn	red-blk-blk-red-brn
22kΩ	red-red-org-brn	red-red-blk-red-brn
36kΩ	org-blu-org-brn	org-blu-blk-red-brn
43kΩ	yel-org-org-brn	yel-org-blk-red-brn
47kΩ	yel-vio-org-brn	yel-vio-blk-red-brn
56kΩ	grn-blu-org-brn	grn-blu-blk-red-brn
82kΩ	gry-red-org-brn	gry-red-blk-red-brn
100kΩ	brn-blk-yel-brn	brn-blk-blk-org-brn
120kΩ	brn-red-yel-brn	brn-red-blk-org-brn
180kΩ	brn-gry-yel-brn	brn-gry-blk-org-brn
390kΩ	org-wht-yel-brn	org-wht-blk-org-brn
470kΩ	yel-vio-yel-brn	yel-vio-blk-org-brn
820kΩ	gry-red-yel-brn	gry-red-blk-org-brn
1.2MΩ 5%	brn-red-grn-gld	brn-red-blk-yel-brn
4.7MΩ 5%	yel-vio-grn-gld	yel-vio-blk-yel-brn
8.2MΩ 5%	gry-red-grn-gld	gry-red-blk-yel-brn
10MΩ 5%	brn-blk-blu-gld	brn-blk-blk-grn-brn
4.7MΩ Philips VR37	yel-vio-grn-red	yel-vio-blk-yel-brn-red

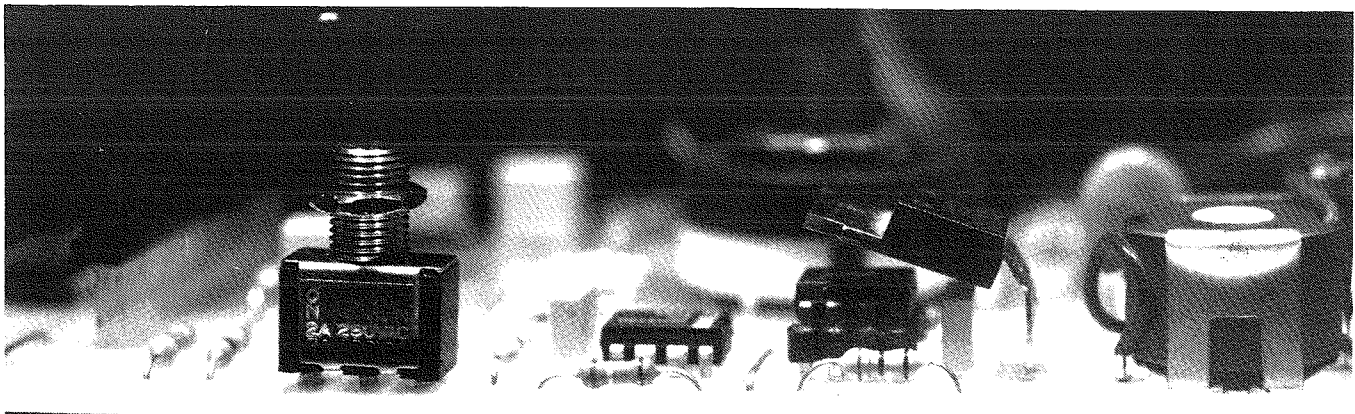

**Bend Q1 over as shown in this photograph, so that it doesn't foul the front panel. The LEDs 1-10 are installed so that their top surface is 15mm above the PC board.**

oriented correctly, and solder the windings.

A plastic case measuring 196 x 113 x 60mm is used to house the assembled PC board. This is supplied with a pre-punched and screened front panel.

Begin the final assembly by affixing to the front panel, switches S3 and the red translucent plastic film. When mounting S3 you will need to trim down the two M2 x 5mm screws to 3mm lengths. This is so that they won't interfere with the switch operation when installed. The red translucent plastic film is glued using contact adhesive (not supplied) to the rear side of the front panel only covering the 10 LED display cut out.

Two holes will need to be drilled in the top end of the case for the terminals. Use the terminals as a guide to the hole size. Holes will also have to be drilled in the base of the case for the 9V battery holder. When drilled install the battery holder with 3 x 8BA x 12mm screws and nuts. Once installed trim off excess

screw lengths, so that they will not interfere with the battery (not supplied) when installed.

This done, the front panel can be test fitted to the PC board. Check that everything lines up correctly and make any adjustments as necessary. You may need to adjust the height of the LEDs 1-10 and LED11, for example. When everything is correct, set switch S2 fully anticlockwise and move its locking tab (found under the star washer) to position 5. This ensures that S2 functions as a 5-position switch only.

The external wiring can now be installed. Use a strip of rainbow cable for the connections to S3 and the battery holder and mains-rated cable for the connections to the test terminals. **Important: the leads to the test terminals must be kept well apart, as any leakage between them at the high test voltages used will affect readings.**

### Testing

Before switching the tester on,

remove the test leads and set the TEST VOLTAGE to 1000V. Using a multimeter, measure the battery current with the unit switched on and ensure that it is in the order of 50mA. A current much greater than this can indicate a serious fault such as a reversed transformer winding, shorted tracks, etc.

If the circuit is normal, check that the 9V supply appears at the supply pins of each IC as follows; between pins 8 & 4 of IC1; between pins 8 & 1 of IC2; between pins 7 & 4 of IC3, IC4 and IC5; and between pins 3 & 2 of IC6. There should also be +2V between TP2 and ground.

If everything checks out so far, select the 1000V (or higher) range on your multimeter and connect the positive meter lead to the cathode (striped end) of D3 and the negative lead to ground. Now check that the correct test voltages are selected by switch S2. Note that the correct test voltage cannot be read at the test terminals because of the testers 9.4 Megohm output impedance.

Next, set your multimeter to read DCmV and connect it between TP1 and TP2. This done, set the range switch to the x1 position and slowly adjust VR1 until you obtain a 0mV (or as close to it as possible) reading. **Note: nothing should be plugged into the test terminals during this procedure.**

With VR1 adjusted, check that the LED's work correctly. With the test leads inserted and shorted together, only the <1 LED should be on. With the test leads disconnected, each LED should come on one at a time from left to right until only the OVER RANGE LED is on.

Once all the adjustments have been completed, fit the front panel to the board assembly and secure it by fitting the nuts to switches S1 and S2. Also check that the bottom terminals of S3 are not shorting out against other

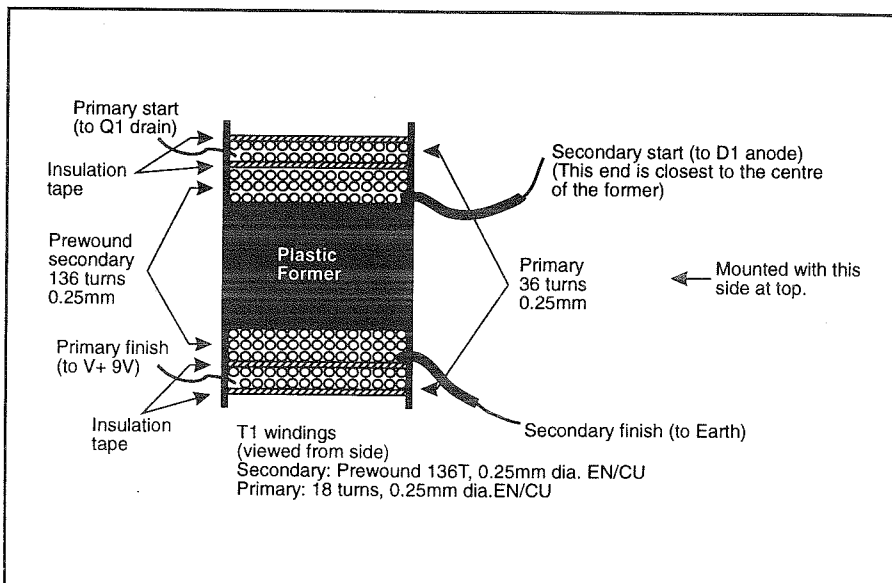

**Fig.4: The secondary of the transformer is already pre-wound at 136 turns. All you need to do is wind on the primary at 40 turns.**

## WARNING

Take care with fully charged capacitors since they can provide a nasty electric shock. Always discharge the capacitor after testing it by switching off the Insulation Tester with the probes connected. A 1 $\mu$ F capacitor will take about 10 seconds to discharge using this technique, while larger values will take proportionally longer.

components. Maybe placing a small piece of insulation tape (not supplied) to the area just under S3 may solve the problem. The unit can then be installed in the case and the knob fitted to S2 and four rubber feet stuck to the bottom of the case to complete the assembly.

### Test leads

It is important to note that maximum resistance readings cannot be obtained from this instrument if the test leads touch each other or are twisted together, or if a standard test lead set is used.

For measurements up to and beyond 220G $\Omega$ , we recommend (optional) high quality test leads such as those from the Fluke range. However the DSE Cat. Q1913 test leads (as supplied) are also capable of meaningful results above 220G $\Omega$ , provided rubber gloves are worn and the leads are not touching a common surface.

Alternatively, you may be able to improve on a standard test lead set by insulating the probes with heatshrink tubing. **In most cases the protective shroud on the test lead banana plugs will have to be cut away to allow them to be inserted into the banana sockets.**

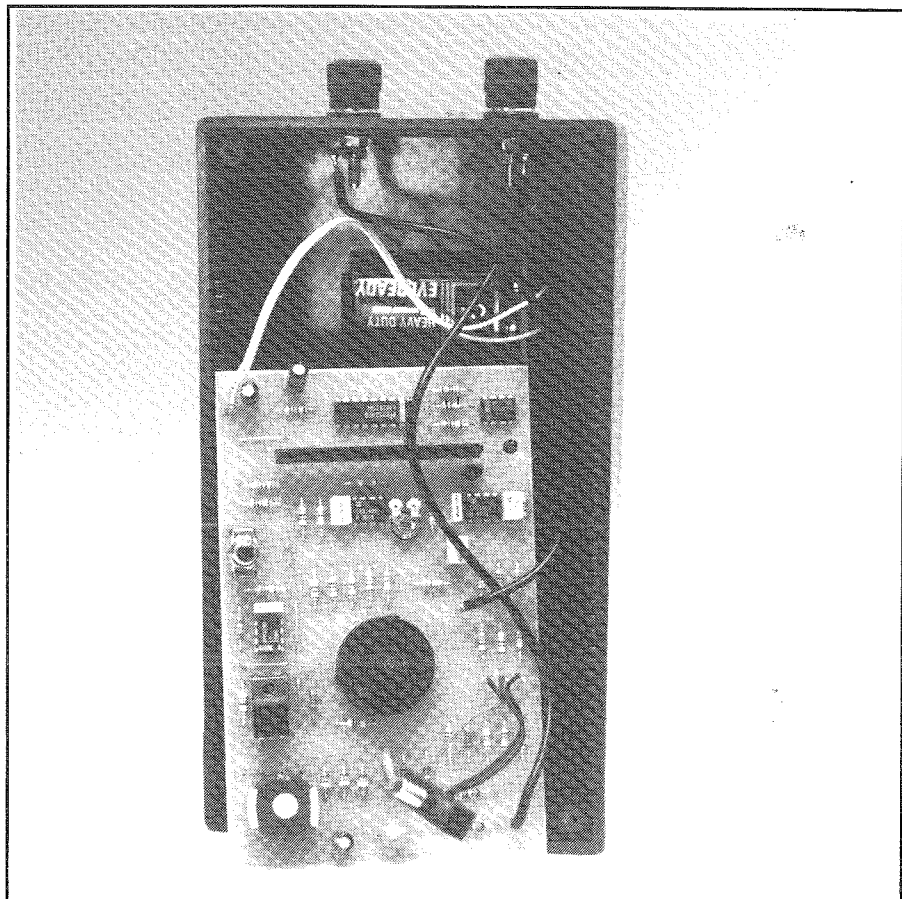

**The completed PC board will mount on the back of the lid and is secured using the nuts for switches S1 and S2. S3 will be secured directly to the lid.**

You can now check the unit by connecting the test leads across the terminals of an unwired switch. The leakage is then determined by first selecting the x1 range and then switching to the next range if necessary. If the display indicates 1G $\Omega$  on the x1 range, then the switch under test is either faulty or its contacts are closed.

Note that the unit will display a reading of 1G $\Omega$  even if the actual resistance is much lower than this.

Finally, when checking capacitors for leakage, be sure to select the correct test voltage. It is then necessary to wait until the capacitor fully charges before taking the reading.

### Notes & Errata