

TM-6035000509

AUTOMATIC
ANTENNA TUNER

GCU-935

OPERATION and MAINTENANCE
MANUAL



SUNAIR

3101 SW Third Avenue, Ft. Lauderdale, FL 33315-3389

(

(

(

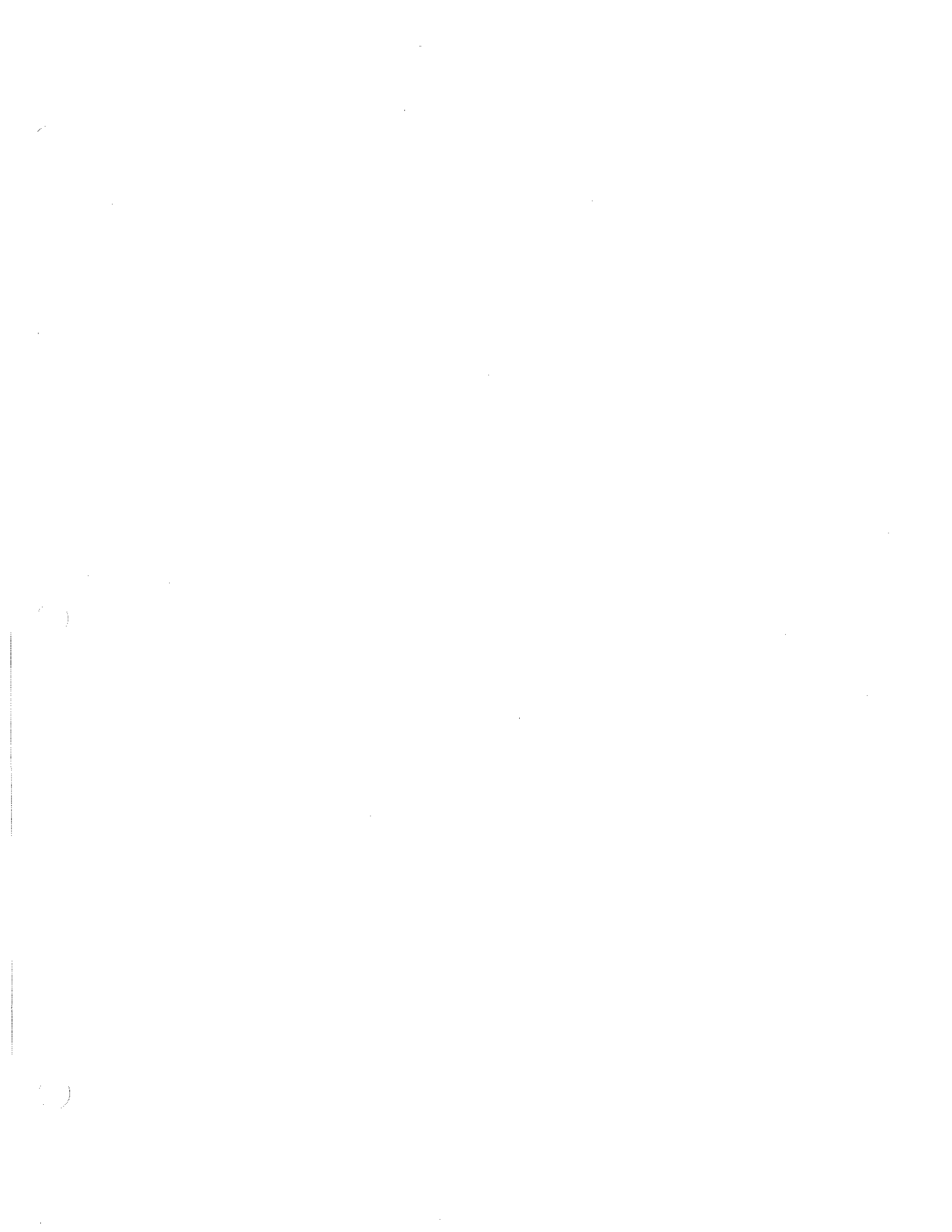



sunair electronics, inc.

3101 S. W. 3rd Avenue, Fort Lauderdale, Florida 33315 USA
Cable: SUNAIR Telex: 51-4443 Phone: (305) 525-1505

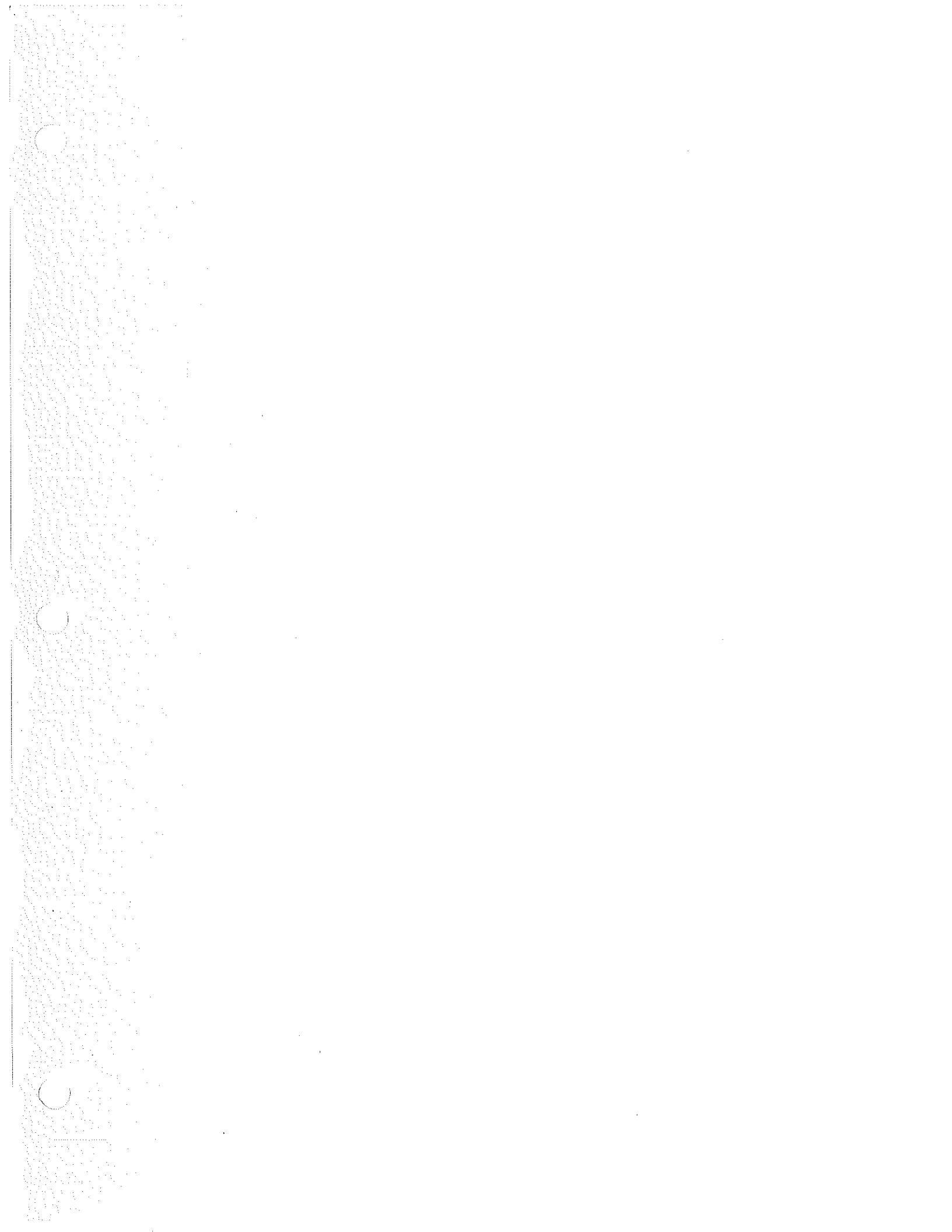

IN CASE OF DIFFICULTY

If your Sunair Electronics, Inc. equipment, develops a malfunction, please follow the steps outlined below to expedite your equipment repair.

1. Note all of the symptoms of the problem, i.e, when does it occur; how often; which modes of operation work, which do not; and anything else which might assist in problem solving.
2. Note model number and serial number.
3. When and from whom (dealer, representative or factory) equipment was acquired.
4. Note peripheral equipment being used in conjunction with the Sunair equipment. Is the peripheral equipment working properly?

After determining the answers to the above, contact your dealer or representative and discuss the problem with him, he may be able to fix the problem locally, avoiding shipping delays. If it becomes necessary to return the equipment to the factory, please follow the procedures outlined in Section II of this manual.

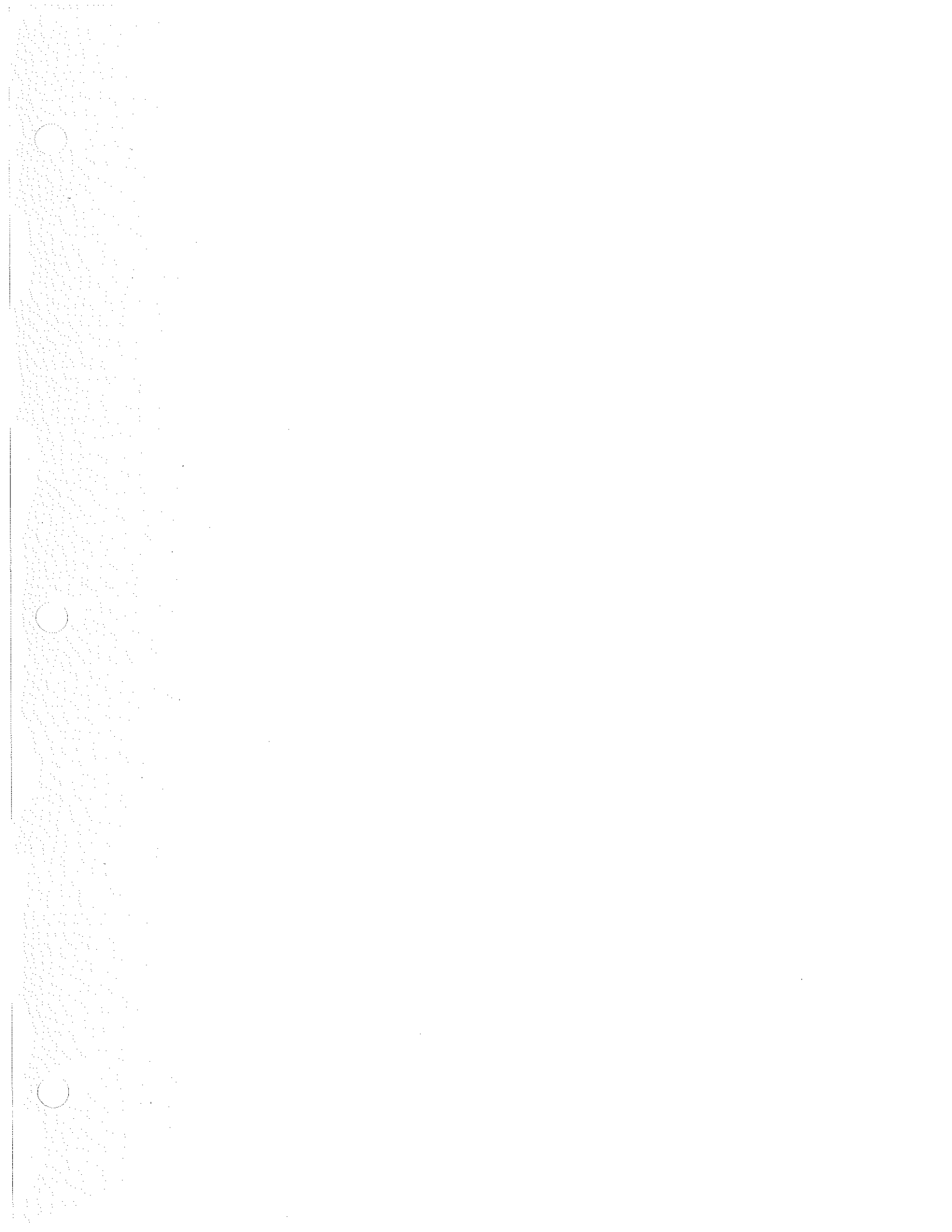



sunair electronics, inc.

3101 S. W. 3rd Avenue, Ft. Lauderdale, Florida 33315 USA

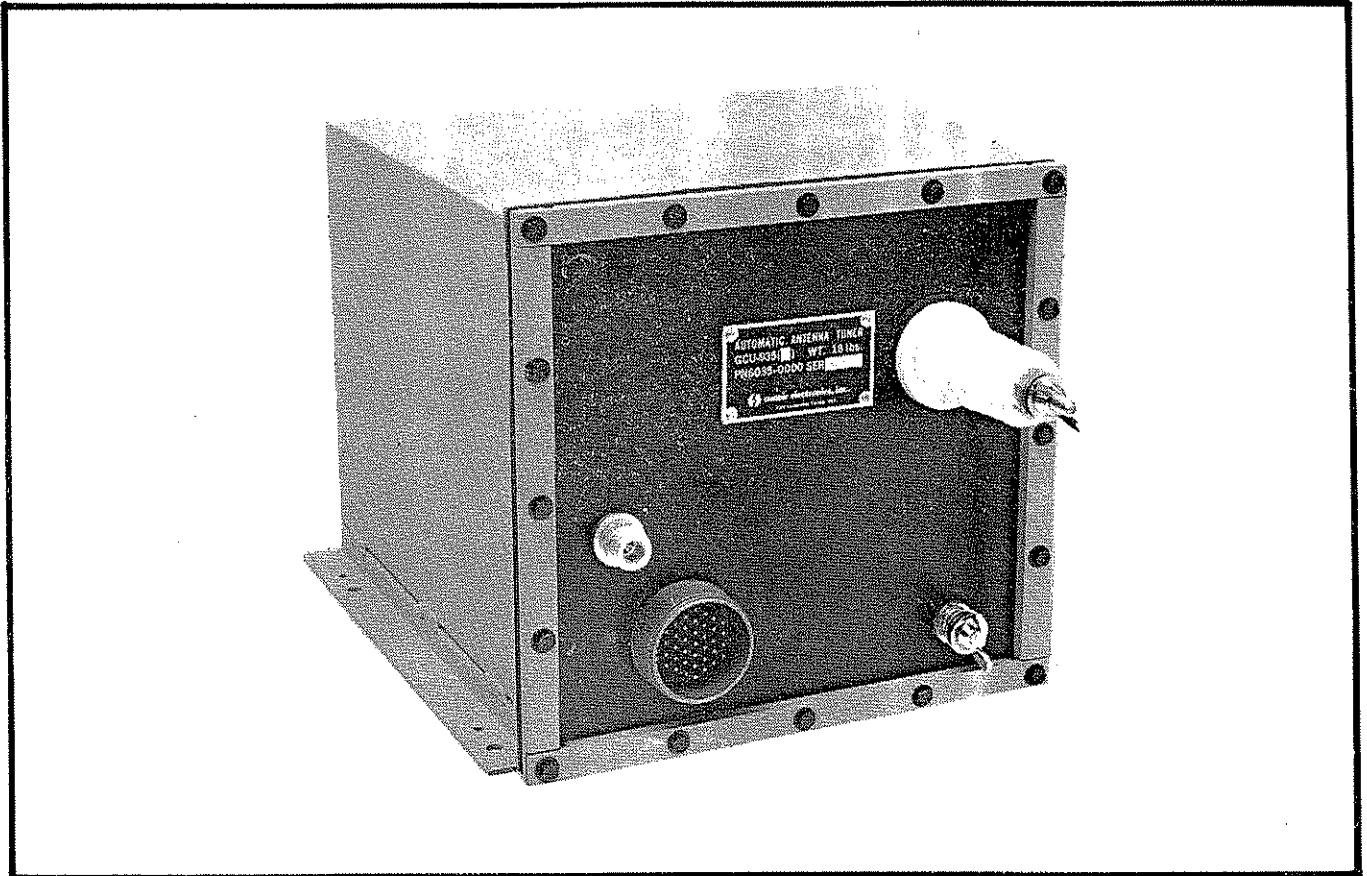

OPERATION AND MAINTENANCE MANUAL

GCU-935

AUTOMATIC ANTENNA TUNER

FOURTH EDITION, 1 AUGUST, 1982
MANUAL PART NUMBER TM-6035000509

(

(

(

PRODUCT SERVICE:

In case of difficulty please contact the Sunair Product Service Department, between the hours of 8:00 AM and 5:00 PM Eastern Time or write to:

Product Service Dept.
Sunair Electronics, Inc.
3101 SW Third Avenue
Ft. Lauderdale, FL 33315-3389
U.S.A.

Telephone: (954) 525-1505

Fax: (954) 765-1322

e-mail: techsupport@sunairhf.com

TRAINING:

Sunair offers training programs of varying lengths covering operation, service, and maintenance of all Sunair manufactured equipment. For details please contact the Product Service Department.

TABLE OF CONTENTS

| Section | Page | Section | Page |
|------------|---|---------|------------|
| I | GENERAL INFORMATION | | 1-1 |
| 1.1 | Scope | | 1-1 |
| 1.2 | Description | | 1-1 |
| 1.2.1 | General | | 1-1 |
| 1.2.2 | Automatic Antenna Tuner Sub-Assemblies | | 1-1 |
| 1.3 | Specifications | | 1-3 |
| 1.4 | Equipment Supplied | | 1-3 |
| 1.5 | Equipment Required – Not Supplied | | 1-3 |
| 1.6 | Optional Equipment – Not Supplied | | 1-4 |
| II | INSTALLATION | | 2-1 |
| 2.1 | Unpacking and Inspection | | 2-1 |
| 2.2 | Reshipping | | 2-1 |
| 2.3 | Power Requirements | | 2-1 |
| 2.4 | Installation Considerations and Mounting Information | | 2-1 |
| 2.4.1 | General Installation Proce- dures and Requirements | | 2-1 |
| 2.4.2 | Mounting Considerations | | 2-2 |
| 2.5 | General | | 2-8 |
| 2.6 | Installation of Remote Control Cable (5024-9050) | | 2-8 |
| 2.7 | Checks After Installation | | 2-11 |
| III | OPERATING | | 3-1 |
| 3.1 | General | | 3-1 |
| 3.2 | GCU-935 Automatic Antenna Tuner Controls | | 3-1 |
| IV | THEORY OF OPERATION | | 4-1 |
| 4.0 | General Theory of Operation | | 4-1 |
| 4.1 | Antenna Tuning Network | | 4-1 |
| 4.2 | Amplitude and Phase Detectors (2A4) Assembly | | 4-1 |
| 4.2.1 | Amplitude Detector | | 4-1 |
| 4.2.2 | Phase Detector | | 4-3 |
| 4.3 | Regulator Board (2A3) and Filter Board (2A3A) (See Figure 5-6) | | 4-3 |
| 4.4 | 3DB Attenuator (See Figure 5-7) | | 4-3 |
| 4.5 | C3 and C6 Control (See Figure 5-8) | | 4-3 |
| 4.5.1 | C6 Control | | 4-3 |
| 4.5.2 | C3 Control | | 4-4 |
| 4.6 | Servo Motor Control Assembly (2A6) (Figures 5-4 and 5-6) | | 4-4 |
| 4.7 | Control Logic (2A1) | | 4-5 |
| 4.7.1 | Reflected Power Amplifier | | 4-5 |
| 4.7.2 | Time Delay Circuit | | 4-5 |
| 4.7.3 | Tune BSMV | | 4-6 |
| 4.7.4 | Fault BSMV | | 4-6 |
| 4.7.5 | 50 Ohm BSMV | | 4-6 |
| 4.7.6 | Lamp Drivers | | 4-6 |
| 4.7.7 | RF Detector | | 4-7 |
| 4.7.8 | Other Circuitry | | 4-7 |
| 4.7.9 | Diode Function List | | 4-7 |
| 4.8 | Phase and Amplitude Control (2A2) | | 4-10 |
| 4.8.1 | Operations Phase and Amplitude Control | | 4-10 |
| 4.8.2 | Phase Preamp (U1) | | 4-11 |
| 4.8.3 | Amplitude Preamp (U3) | | 4-12 |
| 4.8.4 | Phase and Amplitude Level Changer | | 4-12 |
| 4.8.5 | Positive and Negative Phase Detectors | | 4-12 |
| 4.8.6 | 50 Ohm Detector | | 4-12 |
| 4.8.7 | Lmin-Cmax Gate | | 4-12 |
| 4.8.8 | Positive and Negative Phase Driver | | 4-12 |
| 4.8.9 | Greater and Less than Drivers | | 4-12 |
| 4.8.10 | Lmin, 0 Phase, Greater than 50 Ohm Detector | | 4-13 |
| 4.8.11 | Positive Greater than 50 Ohm Detector | | 4-13 |
| 4.8.12 | C1 Home BSMV | | 4-13 |
| 4.8.13 | L4 Home BSMV | | 4-13 |
| 4.8.14 | L4 Force BSMV | | 4-14 |
| 4.8.15 | Phase Shorting Switch | | 4-14 |
| 4.8.16 | Amplitude Shorting Switch | | 4-14 |
| 4.8.17 | Brake Circuit | | 4-14 |
| 4.8.18 | Lmin Pulse Reversing Circuit | | 4-14 |
| 4.8.19 | Lmax Reversing Circuit | | 4-14 |
| 4.8.20 | Other Components | | 4-15 |
| 4.8.21 | Diode Function List | | 4-15 |
| 4.9 | Typical Tuning Sequence | | 4-18 |

(

(

(

TABLE OF CONTENTS (CONT'D)

| Section | Page | Section | Page |
|------------|--|---------|------------|
| V | MAINTENANCE AND REPAIR | | |
| | 5.1 Periodic Maintenance | | 5-1 |
| | 5.2 Troubleshooting and Repair | | 5-1 |
| | 5.3 Required Test Equipment | | 5-1 |
| | 5.4 Fault Isolation | | 5-1 |
| | 5.5 Test and Repair | | 5-5 |
| | 5.6 2XA1 Voltage Test | | 5-5 |
| | 5.7 2XA1 Grounding Test | | 5-5 |
| | 5.8 2XA1 Troubleshooting | | 5-5 |
| | 5.9 2XA2 Voltage Test | | 5-5 |
| | 5.10 2XA2 Grounding Test | | 5-5 |
| | 5.11 2XA2 Troubleshooting | | 5-8 |
| | 5.12 2A6 Servo Motor Control Assembly | | 5-8 |
| | 5.13 2A1 and 2A2 Test | | 5-8 |
| | 5.14 2A1 Functional Test | | 5-8 |
| | 5.15 2A2 Functional Test (GSB-900 Mode Switch in CPLR Tune Position and with 2XA6 Removed from 2A6) | | 5-13 |
| | 5.16 Entire GCU-935 Functional Test. | | 5-13 |
| | 5.17 2A2 and 2A6 Home and Force Functions | | 5-13 |
| | 5.18 GCU-935 Internal Adjustments L Max, L Min, C Max and C Min Limit Switch Settings Should be Checked on a Periodic Maintenance Schedule | | 5-14 |
| | 5.19 Inductor L4 Maximum and Mini- mum Limit Switch Adjustment | | 5-14 |
| | 5.20 Capacitor C1 C Max and C Min Adjustment | | 5-14 |
| | 5.21 Phase and Magnitude Detector Adjustment | | 5-15 |
| | 5.22 Amplitude Detector Adjustment | | 5-15 |
| | 5.23 Phase Detector Adjustment | | 5-15 |
| | 5.24 Reflected Power Detector Check | | 5-16 |
| | 5.25 2A4 Repair | | 5-16 |
| VI | ILLUSTRATED PARTS BREAKDOWN | | 6-1 |
| VII | PHOTOGRAPHIC CALLOUTS | | 7-1 |

(

(

(

LIST OF ILLUSTRATIONS

| Figure | | Page |
|--------|--|------|
| 1.1 | GCU-935 Top and Bottom View | 1-2 |
| 2.1 | Outline Mounting Details GCU-935. | 2-3 |
| 2.2 | Shock Isolators | 2-4 |
| 2.3 | Typical Base Station Installation Using Non-Resonant Antennas. | 2-5 |
| 2.4 | Typical Vehicular Installation | 2-6 |
| 2.5 | Antenna Tuner Grounding | 2-7 |
| 2.6 | The Whip Antenna. | 2-9 |
| 2.7 | The Long Wire Antenna | 2-9 |
| 2.8 | Wiring Chart: Remote Control Cable 0588680001 for GCU-935. | 2-10 |
| 3.1 | Operating Controls | 3-2 |
| 4.1 | Block Diagram GCU-935 Automatic Antenna Tuner | 4-2 |
| 5.1 | GCU-935 Chassis Wiring Schematic. | 5-19 |
| 5.2 | 2A1 Control Logic Schematic | 5-23 |
| 5.3 | 2A2 Phase and Amplitude Control Schematic | 5-25 |
| 5.4 | 2A6 Servo Amplifier Schematic | 5-27 |
| 5.5 | GCU-935 Antenna Tuning Control Unit Schematic | 5-29 |
| 6.1 | Chassis, Exploded View A. | 6-3 |
| 6.2 | Chassis, Exploded View B. | 6-5 |
| 6.3 | Front Panel Assy. | 6-7 |
| 6.4 | Rear Panel Assy. | 6-9 |
| 6.5 | C1 Assy. | 6-11 |
| 6.6 | Relay Assy. K2 & K3 | 6-13 |
| 6.7 | PC Assy. Phase and Amp. Detector | 6-15 |
| 6.8 | Coupler Tuning Control | 6-17 |
| 7.1 | GCU-935 W/Cover. | 7-3 |
| 7.2 | GCU-935 Top View | 7-4 |
| 7.3 | GCU-935 Left View. | 7-5 |
| 7.4 | GCU-935 Right View | 7-6 |
| 7.5 | GCU-935 Bottom View | 7-7 |
| 7.6 | GCU-935 Bottom View, 2A1 Removed | 7-8 |
| 7.7 | GCU-935 Bottom View, 2A2 Removed | 7-9 |
| 7.8 | GCU-935, 2A4 W/O Cover | 7-10 |
| 7.9 | GCU-935 Control Panel | 7-11 |

LIST OF TABLES

| Table | | Page |
|-------|--|------|
| 4.1 | Diode Function List, 2A1 | 4-8 |
| 4.2 | Diode Function List, 2A2 | 4-15 |
| 5.1 | Fault Isolation | 5-2 |
| 5.2 | 2XA1 Connector Voltages (with 2A1 and 2A2 Removed) | 5-6 |
| 5.3 | 2XA2 Connector Voltages (with 2A1 and 2A2 Removed) | 5-7 |
| 5.4 | 2A1 DC Voltages. | 5-9 |
| 5.5 | 2A2 DC Voltages. | 5-11 |

(

(

(

WARNING

WITH CERTAIN TYPES OF ANTENNAS, SEVERAL KILOVOLTS MAY BE PRESENT AT THE OUTPUT INSULATOR, E1, OF THE ANTENNA COUPLER WHEN TRANSMITTING. THE RADIO OPERATOR AND SERVICE TECHNICIAN SHOULD EXERCISE CAUTION NOT TO CONTACT E1 WHILE TRANSMITTING.

(

(

(

SECTION I GENERAL INFORMATION

1.1 SCOPE

This instruction manual contains information necessary to install, operate, maintain and repair the GCU-935 Automatic Antenna Tuner and its associated Antenna Tuning Control Unit.

1.2 DESCRIPTION

1.2.1 GENERAL

The GCU-935 is a high quality remote controlled antenna tuner capable of matching a wide variety of antennas ranging from 9 ft. whips to 150 ft. long wires over a frequency range of 1.6 to 30 MHz. In addition, the tuner may be used as a "line flattener" to correct the V.S.W.R. of resonant antennas. The unit is designed for use with 100 watt 50 ohm transmitters and receivers. The GCU-935 is designed to operate in conjunction with the Antenna Tuning Control Unit (60351500XX) and Exciter to 935 Cable Assembly (6035004008) at separations of up to 200 feet. The coupler variable elements are adjusted by two motors which are controlled by the phase and amplitude detectors in the Antenna Tuner. Fixed elements in the coupler are controlled by the Control Logic Module, 2A1. Tuning cycles are initiated by depressing the TUNE push button in the Antenna Tuning Control Unit. Tuning status lamps and a meter for indicating forward and reflected power are located in the Tuning Control Unit. The control unit is normally located on the front panels of SUNAIR GSB-900 Synthesized SSB transceivers but may be readily adapted for use with other 100 watt transmitters or receivers. The tuner is mounted in a sturdy, fully gasketed case designed for outside mounting near the antenna.

1.2.2 AUTOMATIC ANTENNA TUNER SUB-ASSEMBLIES

1.2.2.1 Control Logic (2A1): This plug in PC board provides the logic outputs for initiating a

TUNE cycle, ending a tune cycle, and controlling the operation of the other sub-assemblies.

1.2.2.2 Phase and Amplitude Control (2A2): This plug in PC board contains the phase and amplitude servo preamplifiers and drives the Servo Motor Control Assembly. The inputs to 2A2 are provided by the phase and amplitude detectors.

1.2.2.3 Filter Board (2A3): The filter board is a wired in assembly and provides filtering of RF to prevent radiation from the coupler control cable.

1.2.2.4 Phase and Amplitude Detectors (2A4): This sub-assembly is connected in series with the RF input between the 3 db attenuator and the tuning elements. It provides the outputs to indicate an inductive or capacitive phase and an amplitude greater than or less than 50 ohms. The phase detector output controls the motor driven capacitor while the amplitude detector output controls the motor driven inductor.

1.2.2.5 C3 and C6 Control Assembly (2A5): Two Bi-Stable relays mounted on this assembly are used to control the two high voltage relays (K2 and K3) which switch C3 and C6 into the tuning network.

1.2.2.6 Servo Motor Control Assembly (2A6): The two servo motors are driven from this assembly. It contains eight TO-3 transistors that are configured as bridges for driving the motors.

1.2.2.7 3 DB Attenuator Assembly: This assembly contains a relay for switching in a 3 db pad in series with the transmitter during the tuning cycle.

1.2.2.8 Chassis Assembly: Provides the required mounting surfaces for the various electrical and mechanical components.

(

(

(

TOP VIEW

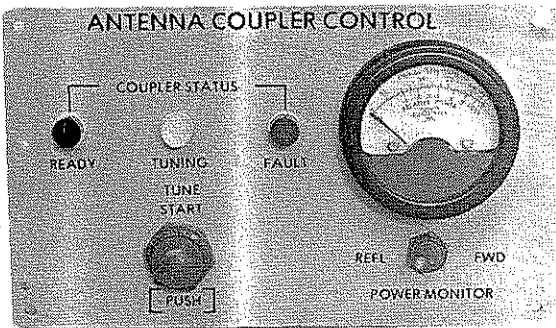
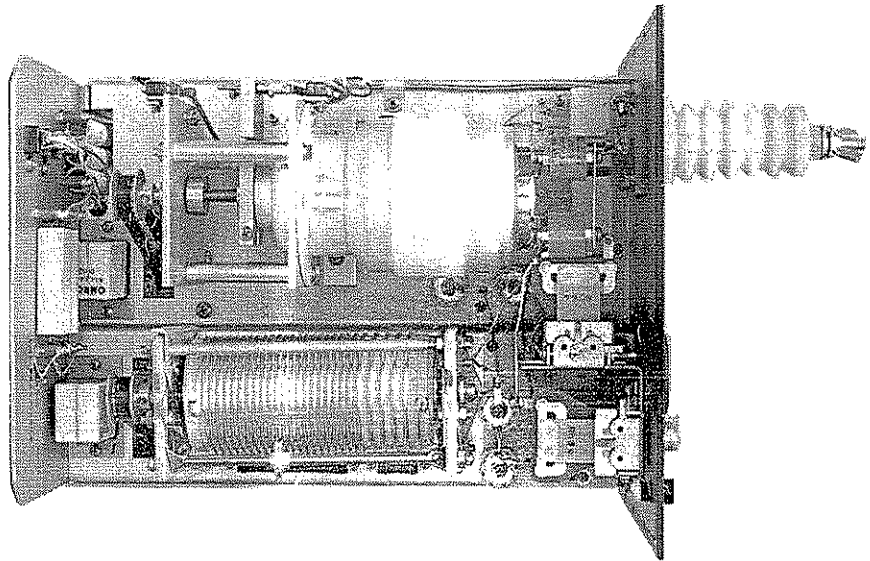

CONTROL HEAD

BOTTOM VIEW

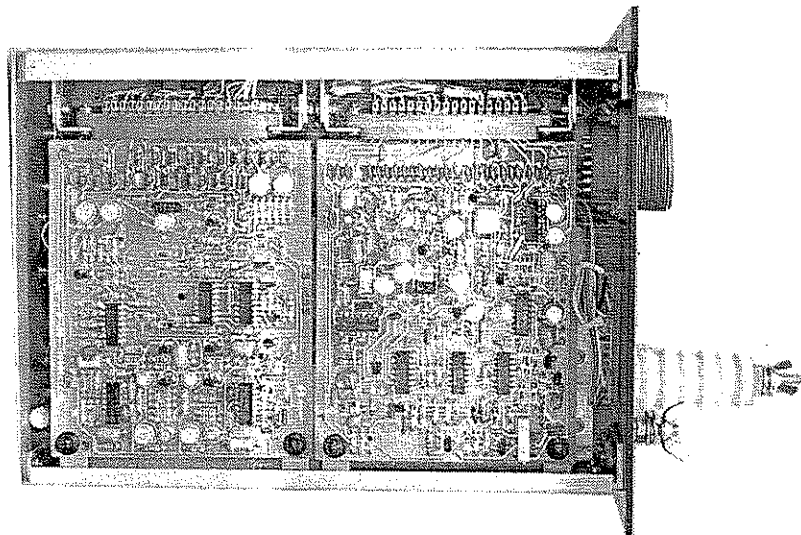

Figure 2.4 Typical Vehicular Installation

(

(

(

1.3 SPECIFICATIONS

- 1.3.1 Operating Frequency Range: 1.6 to 30 MHz.
- 1.3.2 RF Input Power: Designed to operate with equipment supplying 100 watts P.E.P. and average.
- 1.3.3 Input Impedance: 50 ohms, non-reactive.
- 1.3.4 Antenna Matching Capabilities:
 - 9 ft. whips
 - 16 ft. whips
 - 24 ft. whips
 - 32 ft. whips
 - 50 to 150 ft. long wire.
 - Also suitable for use as a line flattener.
- 1.3.5 Tuning Time: Typical 3 sec. worst case (-30°C: 1.6 MHz) 40 sec.
- 1.3.6 Tuning Accuracy: 1.5:1 VSWR maximum.
- 1.3.7 Tune Power: 25 watts delivered.
- 1.3.8 Remote Capability: 200 ft.
- 1.3.9 ENVIRONMENTAL
 - 1.3.9.1 Storage Temperature Range: -55 to +85°C.
 - 1.3.9.2 Operating Temperature Range:
 - 30 to +65°C 100 watts P.E.P.
 - 30 to +50°C 100 watts average.
 - 1.3.9.3 Humidity: Mil Std 810, Method 507, Proc 1.
 - 1.3.9.4 Shock: Mil Std 810, Method 516.1, Proc 1. (See 2.4.2 - Mounting Considerations.)
 - 1.3.9.5 Vibration: Mil Std 810, Method 514.1, Proc VIII. Mil Std 167, Type I. (See 2.4.2 - Mounting Considerations.)
 - 1.3.9.6 Dust: Mil Std 810, Method 510, Proc 1.
 - 1.3.9.7 Rain: Mil Std 810, Method 506, Proc 1.
 - 1.3.9.8 Packaging: Splashproof - for exposed installations.

- 1.3.9.9 Size: 11.25 x 9.0 x 8.72 LWH (Automatic Antenna Tuner) 28.4 x 22.8 x 22.1 Centimeters. 5.5 x 3.5 x 2 LWD (Antenna Tuning Control Unit 60351500xx) 13.9 x 8.9 x 5.1 Centimeters.
- 1.3.9.10 Weight: 18 lbs., 8.1 Kg.
- 1.3.9.11 Power Input: 28V, 2.8 Amps Tuning, 1.1 Amps operate.

1.4 EQUIPMENT SUPPLIED

| | SUNAIR PART NO. |
|--|----------------------------------|
| 1.4.1 Automatic Antenna, Tuner, GCU-935 | 6035003052 GRY 6035003095 GRN |
| 1.4.2 Antenna Tuning Control Unit, GCU-935 | 6035150055 GRY 6035150098 GRN |
| 1.4.3 Connector Kit, GCU-935 | 6035002099 |

Consisting of:

| | |
|--------------------------------|------------|
| Bushing, Telescoping, .56ID | 0700550054 |
| Bushing, Telescoping, .62ID | 0700550062 |
| Bushing, Telescoping, .75 ID | 0700550071 |
| Connector, RF, N UG-5368B/U | 0747020001 |
| Connector, Power, 37 Pin Round | 0747640009 |
| Connector, RF, N UG-21B/U | 0754140008 |

Note: Connector kit is part of Cable assy: 6035004008

1.5 EQUIPMENT REQUIRED – NOT SUPPLIED

1.5.1 Cable Assembly, Exciter to 935 6035004008
Order by actual length desired. The system will operate with up to 200 ft. of remote control cable.

1.5.2 Cable, Coaxial, RG-58/AU 0588130001
Recommended where separation between transceiver and antenna tuner is less than 100 ft. (Specify length)

1.5.3 Cable, Coaxial, RG-8/U 0588640000
Recommended where separation between transceiver and antenna tuner will exceed 100 ft. (Specify length)

1.5.4 Connector, RF, UHF, PL-259 mates with antenna connector 1A8J1 on GSB-900 series units 0742190005

1.5.5 Connector, Power, 37 Pin Round 0754690008
Male mates with accessory connector 1A8J4 on GSB-900 series units.

NOTE: Part of cable assy. 6035004008

1.5.6 Remote Control Cable 0588680001

NOTE: Part of cable assy. 6035004008

1.6 OPTIONAL EQUIPMENT-NOT SUPPLIED

1.6.1 GSB-900 Series Radio Unit Consult Sunair Sales Dept.

1.6.2 Depot Spares/Coupler Control GCU-935 6035900097

Consists of:

| | |
|--------------------------|------------|
| Switch, Toggle, DPDT | 0334610001 |
| Potentiometer, 10K | 0335900003 |
| Switch, Pushbutton, SPST | 0346520002 |
| Boot, Pushbutton Switch | 0346530008 |
| Boot, Toggle Switch | 0531120007 |
| Lamp Assy. Green (2 ea) | 0841480001 |
| Lamp Assy. Red (2 ea) | 0841490007 |
| Lamp Assy. Amber 2 (ea) | 0841500002 |
| Lamp, Midg. Flange | 0878520007 |
| List of Contents | 1001100026 |
| Meter | 5024042204 |

1.6.3 Field Module Kit GCU-935 6035091091

Consists of:

| | |
|------------------------------|------------|
| List of Contents | 1001120019 |
| PC Assy. Control Logic | 6035010083 |
| PC Assy. Phase & Ampl. Ctrl. | 6035020089 |
| PC Assy. Regulator 2A3 | 6035030092 |
| PC Assy Filter 2A3A | 6035035094 |
| PCB Phase & Ampl. 2A4 | 6035045090 |
| PC Assy. Relay Cont. 2A5 | 6035050093 |
| PC Assy. Servo Cont. 2A6 | 6035060099 |

1.6.4 Doublet Antenna Kit 0996240000

1.6.5 75 ft. Long Wire Antenna Kit 0999200003

1.6.6 150 ft. Long Wire Antenna Kit 0999210009

(

(

(

| | | | | | |
|-------|---|------------|--------|--|--------------------------|
| 1.6.7 | 16 ft. Mobile Fiberglass Whip Antenna, use with items in paragraphs 1.6.8 and 1.6.9 | 0712950001 | 1.6.10 | 23 ft. Fiberglass Marine or Base Station Antenna with self-supporting flange mount | 0715760009 |
| 1.6.8 | Heavy Duty 60°Ball Mount, for use with paragraph 1.6.7 | 0715740008 | 1.6.11 | Heavy Duty strap type Bumper mount | 07157300J2 |
| 1.6.9 | 35 ft. Fiberglass Base Station whip antenna with mount | 0715850008 | 1.6.12 | Special Shock isolator kits (see paragraph 2.4.2, Mounting Considerations) | 6035003397 6035003494 |

(

(

(

THIS PAGE INTENTIONALLY LEFT BLANK.

CAUTION

TO INSURE THAT CABLE HAS NOT BEEN DAMAGED DURING SHIPMENT, ALL CABLE ASSEMBLIES MUST BE CHECKED FOR CONTINUITY OR SHORTS, FROM PIN TO PIN, BETWEEN CONNECTORS BEFORE INITIAL RADIO OR SYSTEM POWER UP.

WARNING

CONNECTORS INSTALLED BY THE CUSTOMER MUST BE WIRED IN ACCORDANCE WITH INSTALLATION INSTRUCTIONS PROVIDED IN THE OPERATION AND MAINTENANCE MANUAL. THE CABLE MUST BE CONTINUITY CHECKED AFTER INSTALLATION AND PRIOR TO RADIO OR SYSTEM POWER UP.

(

(

(

THIS PAGE INTENTIONALLY LEFT BLANK.

(

(

(

SECTION II INSTALLATION

2.1 UNPACKING AND INSPECTION

Unpack and inspect all parts and equipment as soon as received. Do not accept a shipment where there are visible signs of damage to the cartons until a complete inspection is made. If there is shortage or if any evidence of damage is noted, insist on a notation to that effect on the shipping papers before signing the receipt from the carrier.

If concealed damage is discovered after a shipment has been accepted, notify the carrier immediately in writing and await his inspection before making any disposition of the shipment. A full report of the damage should also be forwarded to Sunair. Include the following:

- (a) Order number
- (b) Model and serial number
- (c) Name of transportation agency

When Sunair receives this information arrangements will be made for repair or replacement.

2.2 RESHIPING

The shipping carton for the GCU-935 has been carefully designed to protect the antenna coupler and its accessories during shipment. This carton and its associated packing materials should be retained in case it becomes necessary to reship the coupler. If the original shipping carton is not available, be sure to carefully pack each unit separately, using suitable cushioning material where necessary. Special attention should be given to providing enough packing material around controls, connectors, and other protrusions from the equipment. Rigid cardboard should be placed at the corners of the equipment to protect against denting. Be sure to mark the container "FRAGILE - ELECTRONIC EQUIPMENT".

IMPORTANT NOTE: RETURN OF SUBASSEMBLIES FOR REPAIR

When returning one or more subassemblies for repair, please ship AIR PARCEL POST or AIR FREIGHT consigned to Sunair Electronics, 3101 S.W. 3rd Avenue, Fort Lauderdale, Florida, 33315 U.S.A., and plainly mark on all mailing documents:

"U.S. GOODS RETURNED FOR REPAIR.
VALUE FOR CUSTOMS - \$100.00".

2.3 POWER REQUIREMENTS

All power necessary to operate the GCU-935 Antenna Tuner is supplied from the companion GSB-900 transceiver and Antenna Tuning Control Unit via the Exciter to 935 Cable Assembly. Consult section 2.6 for cable connections. If a transceiver or transmitter other than the GSB-900 is used, external power sources of +28V D.C. at 2.8 amps and +12V D.C. at 89 ma are required to power the Antenna Tuning Control, it can be derived from the +28V supply by using a 200 ohm, 5 watt wirewound dropping resistor.

2.4 INSTALLATION CONSIDERATIONS AND MOUNTING INFORMATION

The satisfactory operation of the equipment will depend upon the care and thoroughness taken during the installation.

IMPORTANT INSTRUCTIONS

2.4.1 GENERAL INSTALLATION PROCEDURES AND REQUIREMENTS

1. Carefully plan radio/tuner/antenna locations, observing the following requirements before starting installation.
2. Provide best possible RF ground for radio and coupler. Use flat copper strap 1" wide for #6 or larger wire and connect to ground terminal at rear of transceiver. Leads to ground system should be as short as possible.
3. Provide maximum separation between tuner output and the radio with its associated wiring. Tuner may be mounted 100 ft. from radio when RG-8 is used.
4. Antenna lead from antenna tuner to antenna must be insulated for at least 10kv potential. The lead should not run parallel to metal objects that are bonded to the system

(

(

(

ground. The tuner should be as close to the antenna as possible, and never more than 3 ft. as this will decrease antenna efficiency.

5. **If the radio is installed on a wood or fiberglass boat, approximately 10 to 12 square feet of metal surface area in contact with the water should be provided for use as an RF ground.**
6. **If operated on D.C. power, check for correct polarity before applying power.**
7. **The installation should be carefully planned beforehand in accordance with drawings on the following pages.**
8. **Linear amplifiers with low level modulation such as used in the GSB-900 will oscillate if the RF power output is radiated or conducted into the low level stages. Evidence of this situation is erratic or excessive power output. This is caused by too close proximity of the tuner output and antenna to the transmitter and/or inadequate RF grounds. Carefully following the above procedures will prevent this from occurring.**

2.4.2 MOUNTING CONSIDERATIONS

See Figure 2.1 for Tuner outline configuration. Figure 2.2 illustrates two different shock isolator pads. If the GCU-935 is to be installed in a base station that has no vibration or shock environment then shock isolators are not required. For shipboard use where the antenna tuner is mounted in the upright position (horizontal) and the vibration and shock environment does not exceed the requirements of MIL-STD-167, the Type 1 isolators of Figure 2.2 could be used. If the shock and vibration environment exceeds the requirements of MIL-STD-167, the Type 3 shock isolator shown in Figure 2.2 should be used. Both isolators shown in Figure 2.2 are weather resistant and can be used in an exposed installation.

The type of shock isolator used for vehicular installations depends on the type of

vehicle and terrain to be traversed. If the equipment is mounted in a vehicle that travels smooth, paved highways and is not subjected to large shock, then the Type 1 isolator of Figure 2.2 would be adequate, provided the tuner is mounted upright. For installation in Jeeps, personnel carriers or tanks, then the Type 3 isolator would be required.

Generally if the vibration environment is within the requirements of MIL-STD-167, Type 1 isolators will suffice. For those environments that approach MIL-STD-810 requirements, Type 3 isolator should be used.

2.4.2.1 Base Station Installation

A typical base installation consisting of a GSB-900 and GCU-935 is shown in Figure 2.3. Consult the GSB-900 operating manual for installation details. Refer to section 2.5 for recommendations for suitable antennas.

2.4.2.2 Vehicular Installation

Figure 2.4 shows a typical vehicular installation with a GSB-900 transceiver and shock mount assembly (Sunair Part No. 5024-002598). See section 2.5 for specific antenna recommendations. In order to minimize RF pickup, it is important that the ground straps supplied with the shock mount be securely fastened between the ground post on the radio and the bottom of the right rear shock isolator. Consult the GSB-900 manual for further details.

2.4.2.3 Marine Installation

In marine installations, follow the same recommendations as outlined in paragraph 2.4.2.2 above. If the radio is installed in a wood or fiberglass boat, a ground plate of 12 square foot minimum area in contact with the water should be installed. A heavy ground lead such as 1 inch wide strap or braid should be connected between the ground post on the radio and the ground plate. The length of this ground lead should be held to an absolute minimum commensurate with a neat installation.

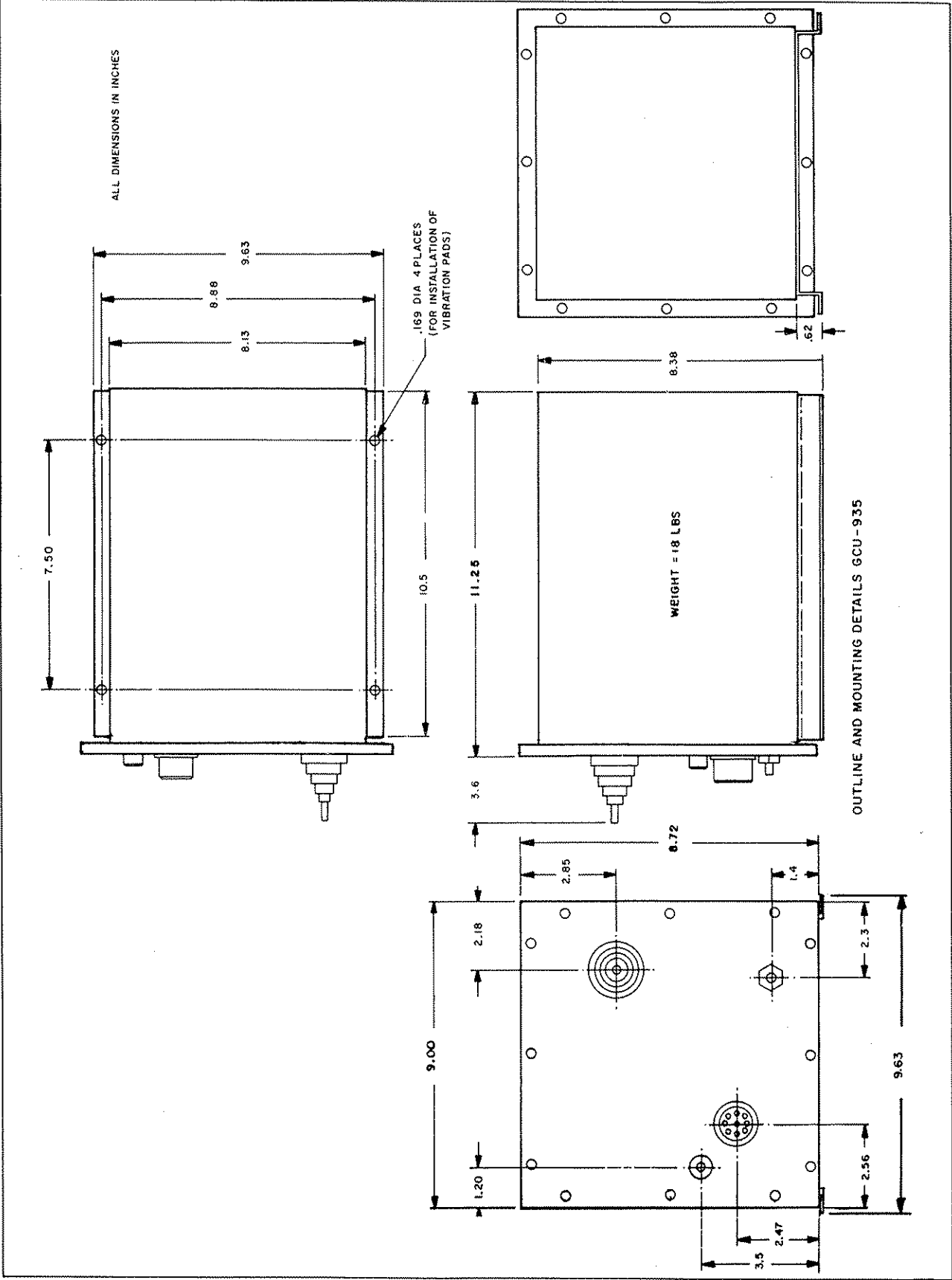
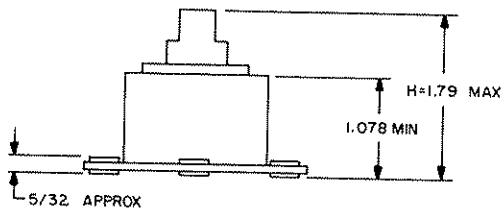
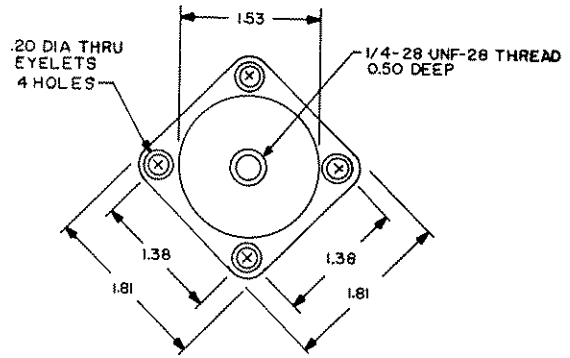
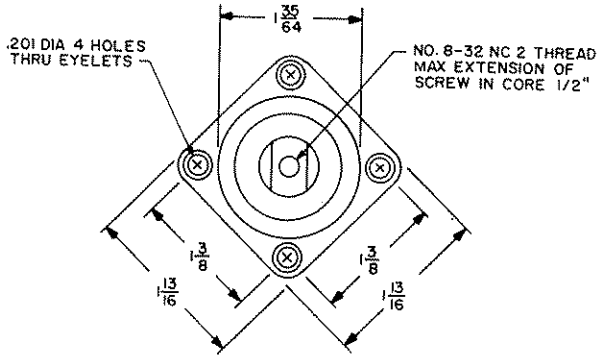

Figure 2.1 Outline Mounting Details GCU-935

(

(

(



VIBRATION PAD MOUNTING DETAIL TYPE 1

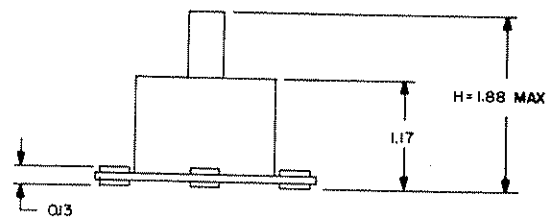

VIBRATION PAD PART NO 84166 MOUNTING DETAIL TYPE 2

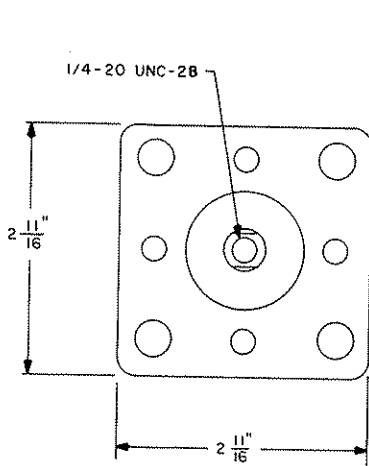

VIBRATION PAD MOUNTING DETAIL TYPE 3

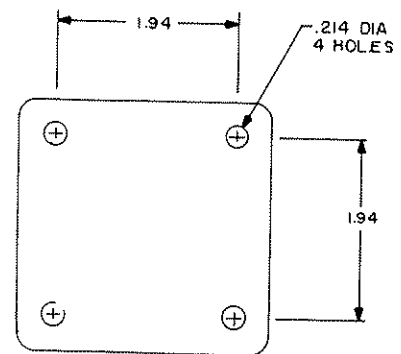
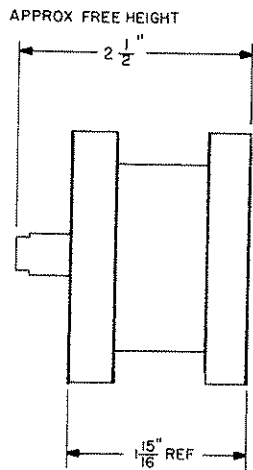

Figure 2.2 Shock Isolators

(

(

(

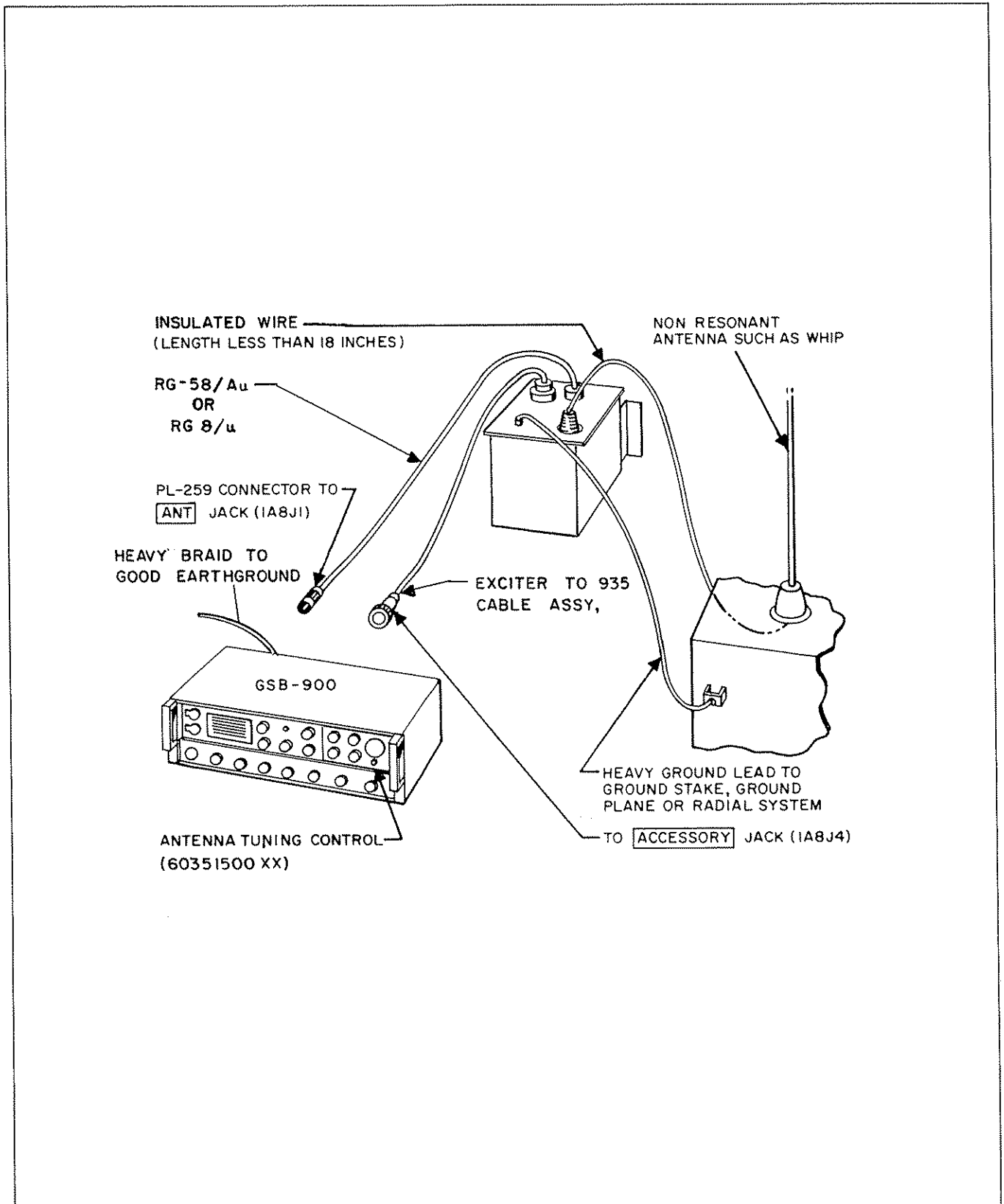

Figure 2.3 Typical Base Station Installation Using Non-Resonant Antennas

(

(

(

SUNAIR GCU-935

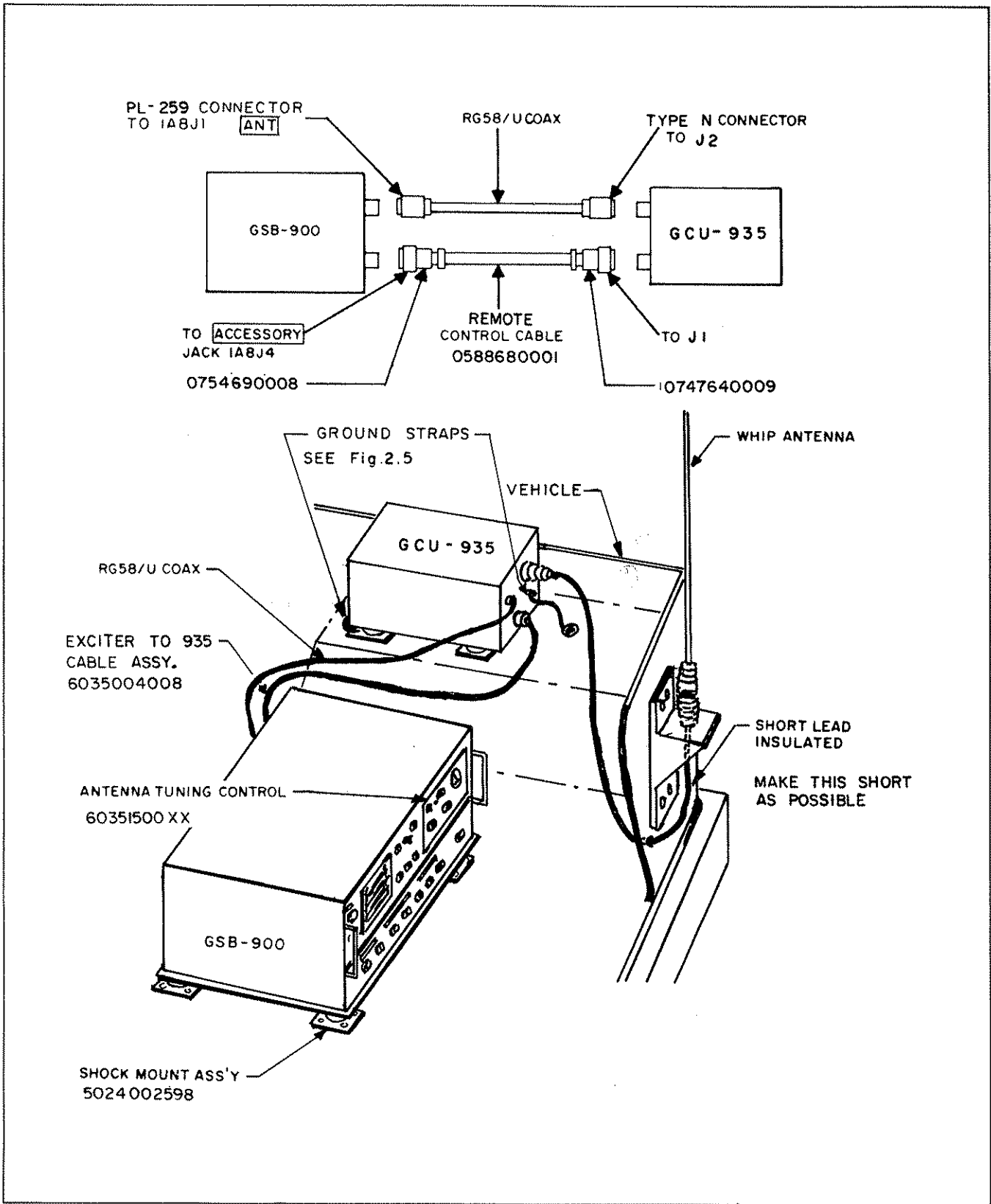

Figure 2.4 Typical Vehicular Installation

(

(

(

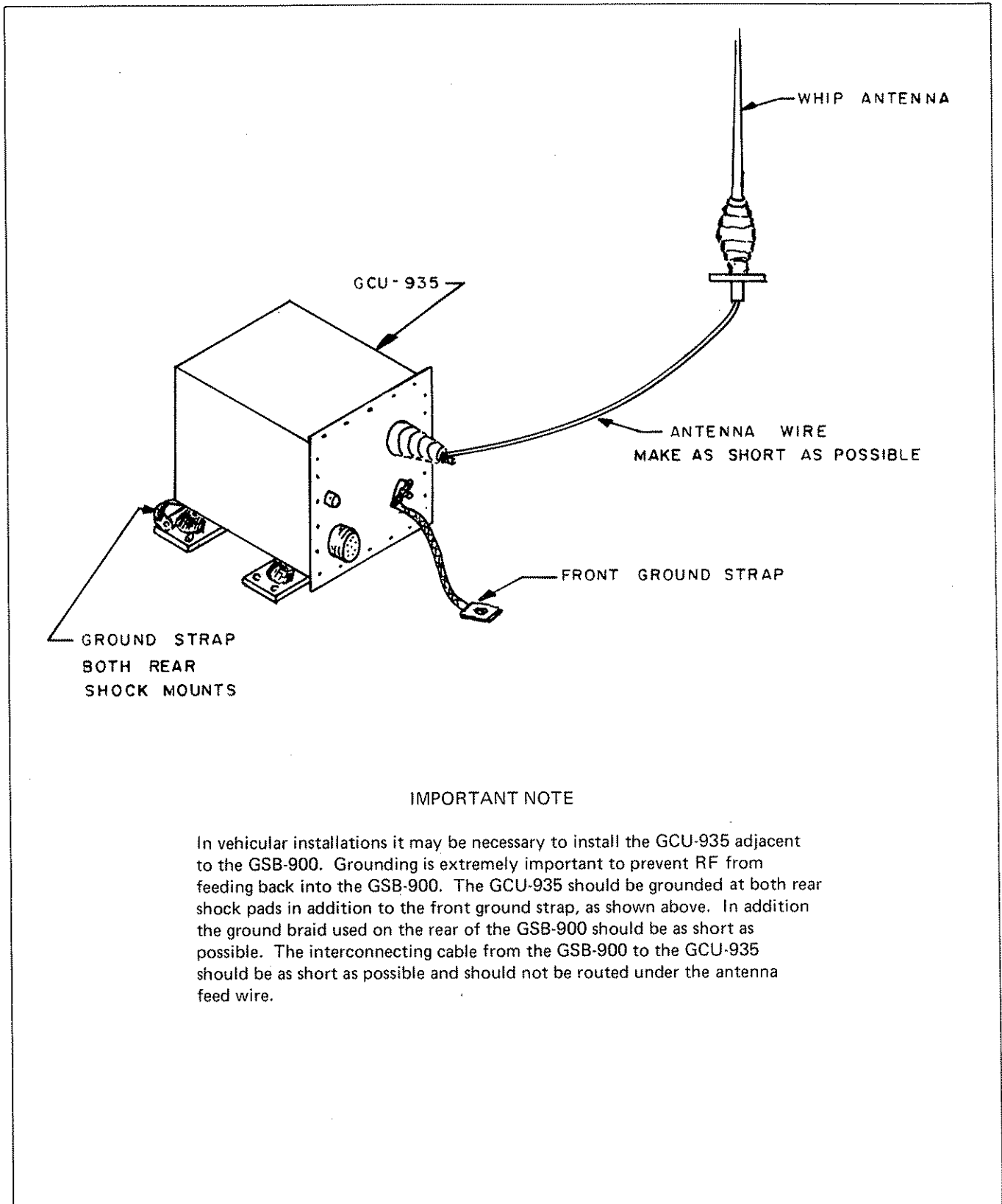

Figure 2.5 Antenna Tuner Grounding

2.5 GENERAL

The GSB-900 is designed to operate into a 50 ohm resistive antenna system with a maximum voltage standing wave ratio (V.S.W.R.) of 2:1. When used with the GCU-935 Remote Controlled Antenna Tuner, the system will match antennas ranging from 9 foot whips to 150 foot long wires. Although the GCU-935 will match 9 foot whips down to 1.6 MHz, use of a 9 foot whip is not recommended due to poor radiation efficiency. The GCU-935 is unique in that it can be placed close to the antenna and controlled from the front panel of the GSB-900 Transceiver. This optimizes both operator convenience and electrical performance. As there are numerous types of antennas, a complete discussion is beyond the scope of the manual. Antennas requiring an antenna coupler for use in the 1.6 to 30 MHz spectrum generally fall into two categories:

- a) Narrow band 50 ohm antennas
- b) Random length non resonant antennas

Several popular antennas falling into each of the above categories are discussed below. For specific recommendations, consult our experienced Field Service organization.

2.5.1 Long Wire Antenna

The long wire antenna, illustrated in Figure 2.7, is a popular base station antenna where a wide range of operating frequencies are used. The antenna impedance varies greatly with frequency and therefore must be matched to the Transceiver with the GCU-935 antenna tuner. The GCU-935 antenna tuner will efficiently match long wire antennas up to 150 foot in length. The radiation pattern of the long wire antenna is also a strong function of operating frequency. The two most popular length long wire antennas, 75 and 150 foot available from Sunair, exhibit excellent low frequency radiation efficiency.

2.6 INSTALLATION OF REMOTE CONTROL CABLE (0588680001)

It is recommended that the remote control cable be procured from Sunair. However, if necessary the cable may be made from individual wires of

#20 AWG with an overall braided shield and PVC jacket.

The remote control cable may be shipped from the factory without connectors attached to facilitate the routing of this cable through walls, bulkheads, conduit, etc. After installing the cable, follow the procedure outlined below.

NOTE

The connector with the male pins (0754690008) should be wired at the transceiver end of the cable.

The connector with female pins (0747640009) should be wired at the antenna tuner end of the cable. Refer to wire chart, Figure 2.8.

1. Loosen both screws on one of the cable clamps.
2. Insert the rubber telescoping bushing (boot) through the rubber grommet on the inside of the cable clamp and push through until the lip on the boot bottoms on the rubber grommet. The boot should extend beyond the cable clamp.
3. Insert the remote control cable (0588-680001) into the open end of the boot and cable clamp and pull through until approximately 6 inches of cable extends from the inside of the cable clamp.
4. Carefully remove approximately 1-½ inches of the plastic outer jacket of the remote control cable using a knife or razor blade. Use care so as not to damage the shield or inner conductors.
5. Carefully unbraided the cable shield to within approximately ¼ inch of the outer jacket. Carefully cut the unbraided shield wires at this point using a pair of small wire cutters.
6. Remove approximately 1 inch of insulation from the end of a 3 inch piece of #22 gauge hook-up wire. Wrap the wire around the outer jacket and solder the connection using a medium size soldering iron.

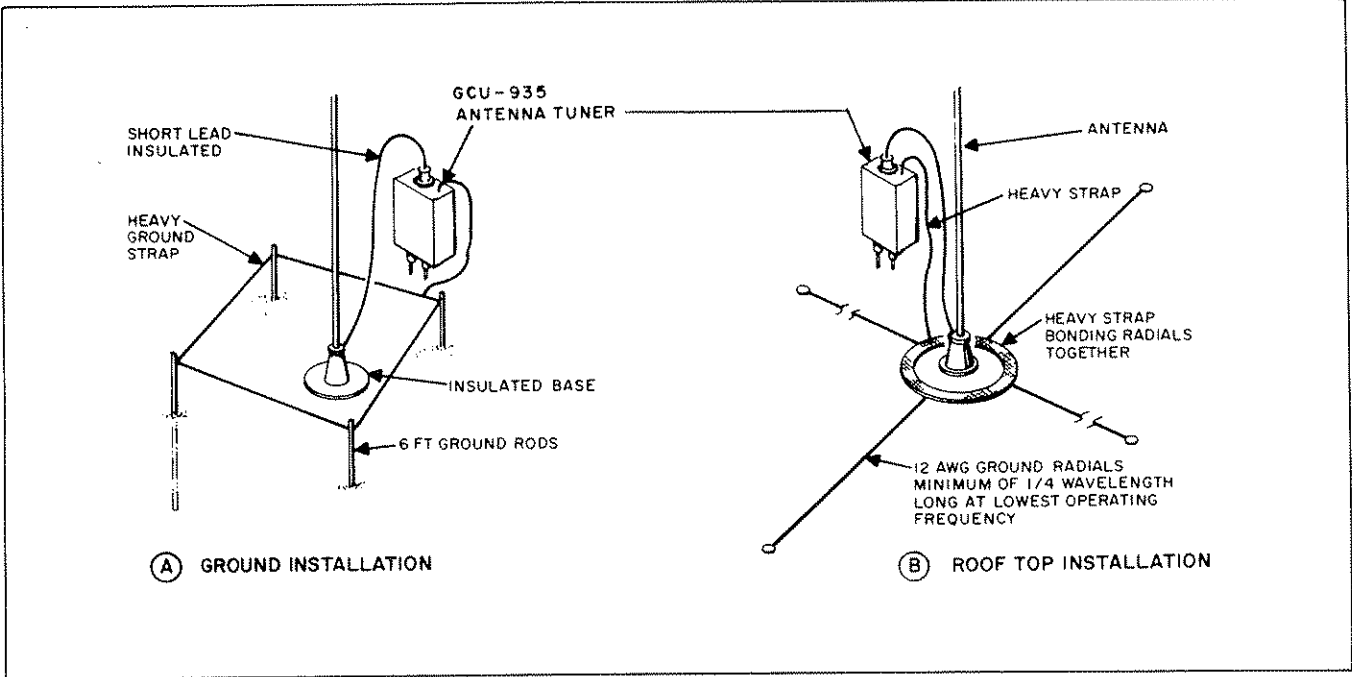

Figure 2.6 The Whip Antenna

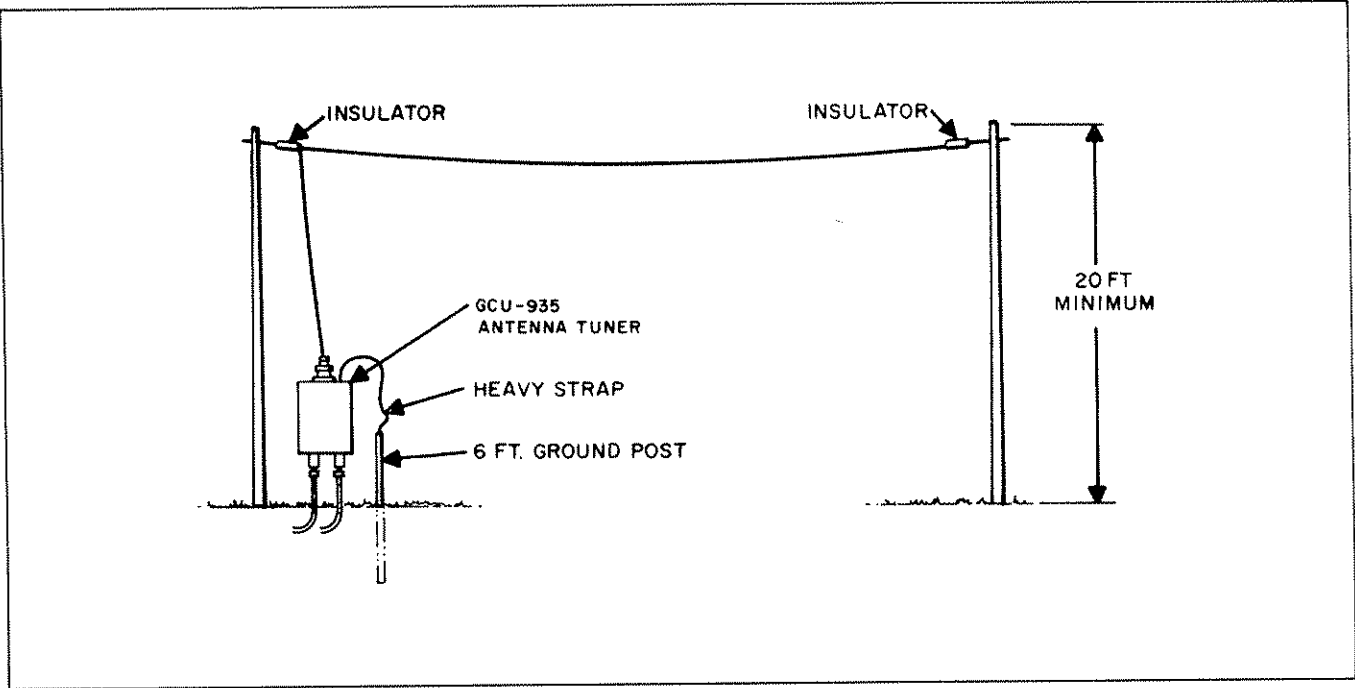

Figure 2.7 The Long Wire Antenna

(

(

(

SUNAIR GCU-935.

| WIRE# | GSB-900 (male) CONNECTOR MS3106E(28-21P) (0754690008) PIN NO. | GCU-935 CONNECTOR MS3106E(28-21S) (0747640009) PIN NO. | FUNCTION |
|---|---|--|-----------------|
| 1 | J | J | CPLR TUNE + |
| 2 | K | K | CPLR TUNE + R |
| 3 | L | L | TUNING |
| 4 | M | M | FAULT |
| 5 | k | k | KW TUNE ** |
| 6 | p | p | INTERLOCK ** |
| 7 | n | n | KEYLINE ** |
| 8 | f | f | Forward Power |
| 9 | g | g | Reflected Power |
| 10 | j | j | CPLR Tune |
| 11 | s | s | +28VDC |
| 12 | h | h | Ground |
| <u>NOTE: ALSO CONNECT CABLE SHIELD TO PIN h</u> | | | |
| 13 | P | P | GAIN |
| 14 | N | N | READY |
| 15 | | | |
| 16 | | | |
| 17 | | | |
| 18 | | | |
| 19 | | | |
| 20 | | | |
| 21 | | | |
| 22 | | | |
| 23 | | | |
| 24 | | | |
| 25 | | | |
| 26 | | | |
| 27 | | | |
| spare (no connection-tie off in cable) | | | |
| <u>NOTE-UNUSED PINS ARE A,B,C,D,E,F,G,H,R,S,T,U,V,W,X,Z,a,b,c,d,e,m,r</u> | | | |
| ** NOTE-To use a GCU-910 cable for a GCU-935, spare wires must be added for n,p, and k. <u>ALSO-THE JUMPER BETWEEN n and p ON 1A8J4 (GSB-900) MUST BE REMOVED.</u> | | | |

Figure 2.8 Wiring Chart: Remote Control Cable (0588680001) for GCU-935

(

(

(

7. Note the mylar sleeve over the wire bundle. Carefully cut this sleeve, being careful not to nick the wires in the bundle, until the wire bundle is exposed back to the end of the shield.
8. Flare out the bundle of wires and separate the individual wires. Strip approximately 1/8 inch of insulation from each wire.
9. Cut a piece of insulated sleeving approximately 1/4 inch long (sleeving is supplied in the ancillary kit of the antenna coupler). Choose one of the wires and carefully tin it. Slip the sleeving over the wire, beyond the tinned area. Solder the wire to one of the cups of the connector. When the connection has cooled, force the insulated sleeving over the cup. Make a chart showing the wire color code and pin connection.
10. Proceed in a similar manner until all required wires are installed.

NOTE

Pin "h" of the connector should have a wire plus the #22 gauge wire from the shield, prepared in step 6 above, soldered to it.

11. When all connections are completed, screw the rear shell and cable clamp assembly on the connector and tighten. Push a small additional amount of cable into the connector to ensure some slack and then tighten the two screws on the cable clamp.
12. Follow an identical procedure to connect the other end of the cable.

NOTE

The cable should be wired pin-to-pin. That is, pin a of one connector should connect to pin a of the opposite connector, etc.

2.7 CHECKS AFTER INSTALLATION

When system installation is complete, perform the following checks:

1. Connect a watt meter and a 50 ohm, 100 watt dummy load to the transceiver output (1A8J1).
2. Turn on the transceiver. The RED Fault light should be illuminated.
3. Place MODE switch on GSB-900 in the AM position and key on with microphone and check AM power on several frequencies. The power output should be between 30 and 40 watts.
4. Place the MODE switch in the CPLR tune position. Key microphone and there should be no power output. Place MODE switch in the KW TUNE position. Key microphone and there should be no power output.
5. With the MODE switch in either CPLR TUNE or KW TUNE position, depress the TUNE button. The amber tuning light should be illuminated and the power output should be 30 to 40 watts. Wait approximately 40 seconds. The transceiver should return to the receive mode and the red light should come on.
6. Remove the dummy load and connect the wattmeter between 1A8J1 (ANT.) and the coax cable feeding the GCU-935 (J2). With the MODE switch in the CPLR TUNE position, depress the TUNE button. The reflected power on the wattmeter should be less than 10 watts and the panel meter should indicate a reading on both FWD PWR and REF PWR positions. The reflected power indicated on the wattmeter and the panel meter should change and finally drop to near zero. At this time the green light should be illuminated.

7. Change the Mode switch to the AM position and key the transmitter. Check forward and reflected power to determine VSWR.
8. Check transmitter on all desired frequencies across the band and note the reflected power.
9. If the reflected power is excessive remove the top cover of the GSB-900 and increase the gain by adjusting the GAIN control (on the rear panel of the Antenna tuning control unit) clockwise. If some frequencies will not tune, decrease the gain by adjusting the GAIN control counter-clockwise. The gain control is adjusted at the factory for approximately mid range and should be satisfactory for most antennas. However, some antennas might require adjustment after the installation is completed.
10. On some frequencies for some antennas, the time delay may run out and the FAULT

light will be illuminated. If this occurs, initiate another tuning cycle.

NOTE

The GCU-935 should always be tuned to the desired operating frequency. The GSB-900 operates in the AM mode for tuning and if SSB operation is desired, the emitted signal on SSB will be approximately 2.0 kHz higher than the AM carrier. Due to antenna selectivity, when operating below 3 MHz, the GCU-935 should be tuned to the SSB emitted signal if SSB operation is desired. For example, if 2638 USB operation is desired, the GCU-935 should be tuned to 2640 (AM) and the GSB-900 changed back to 2638 for USB operation. For LSB operation (below 3 MHz) the coupler should be tuned 2 kHz below the desired LSB GSB-900 frequency.

(

(

(

SECTION III OPERATING

3.1 GENERAL

This section contains information and instructions required for proper operation of the GSB-900 transceiver with the GCU-935 Automatic Antenna Tuner

3.2 GCU-935 AUTOMATIC ANTENNA TUNER CONTROLS (REFER TO FIGURE 3.1)

(Contained on Antenna Tuning Control Panel 60351500XX which mounts in the front panel of the GSB-900.)

TUNE START Initiates a tune cycle. This is the only action required to tune after mode switch is placed in KW/CPLR TUNE.

TUNER STATUS Lights

FAULT This light is illuminated for the following conditions:

1. When the transceiver is initially turned on.
2. When the GSB-900 MODE switch is switched from any position to CPLR TUNE or KW TUNE.
3. When the time delay runs out (approximately 40 seconds after initiation of a tune start pulse).

4. When a tune cycle has been initiated and the GSB-900 MODE switch is moved from CPLR TUNE or KW TUNE positions.

5. Any time the reflected power exceeds a threshold determined by the setting of the GAIN control. (This normally is less than 5 watts reflected power.)

TUNING

This light is illuminated only during a tune cycle (when the transmitter is keyed on).

READY

This light is illuminated after a tuning cycle has been completed and the tuner has tuned to a VSWR less than 1.5:1.

**POWER
MONITOR**

Switches meter input when in TRANSMIT mode:

Switch FWD

Indicates relative forward RF power in coax at the input to the antenna tuner.

Switch REFL

Indicates relative reflected RF power on coax at the input to the antenna tuner. A null in this reading indicates that the antenna is correctly matched to the transceiver.

(

(

(

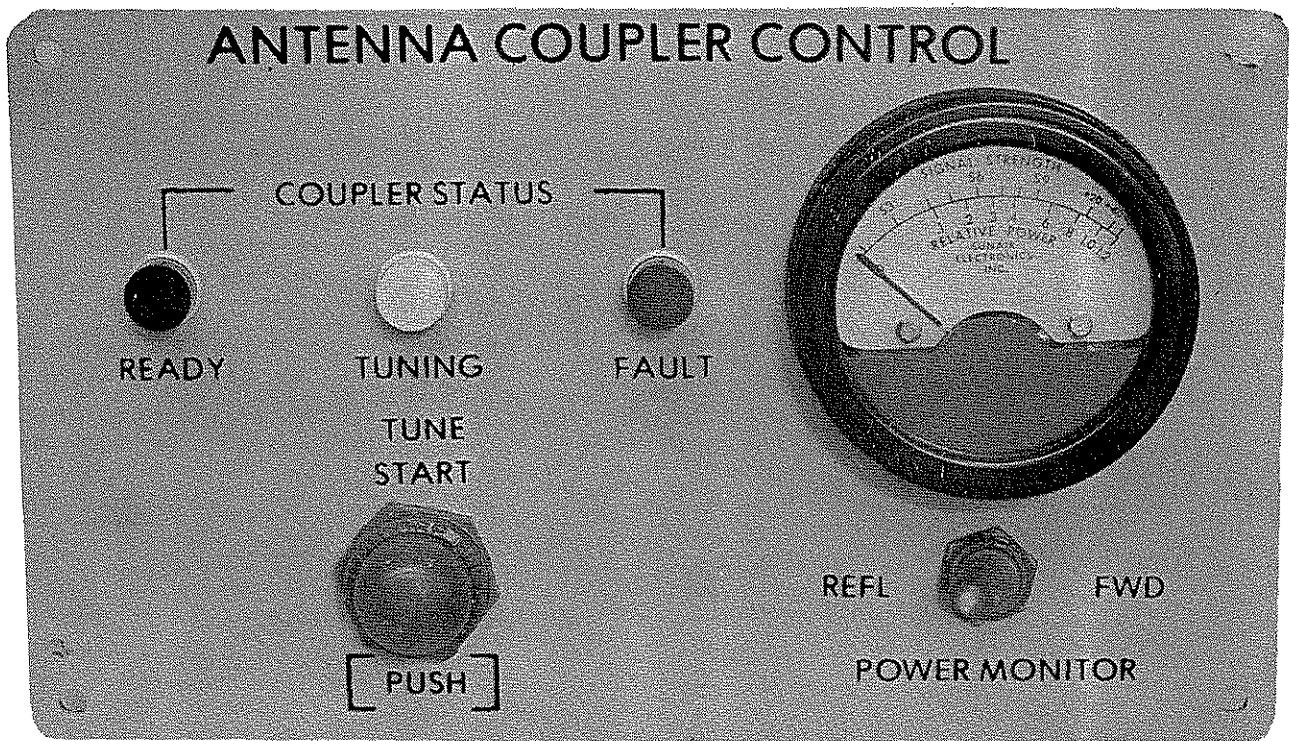

Figure 3.1 Operating Controls

(

(

(

SECTION IV THEORY OF OPERATION

4.0 GENERAL THEORY OF OPERATION

The GCU-935 is a fully automatic antenna tuner designed to be used with the GSB-900 Synthesized Transceiver. The GSB-900 mode switch must be placed in the KW Tune or CPLR Tune position in order to initiate a tune cycle. When the "Tune Start" pushbutton on the GCU-935 control panel (located in the front panel of the GSB-900) is depressed, the tuning cycle begins and is completed when the Green "Ready" light is illuminated. The GSB-900 mode switch is then placed in the desired mode of operation, USB, CW, AM or LSB. Any time the red "Fault" light comes on is an indication that the antenna tuner should be tuned.

4.1 ANTENNA TUNING NETWORK

The antenna tuning network consists of an "L" network with two auxillary capacitors that are automatically switched into the circuit when certain conditions exist. A block diagram of the GCU-935 Automatic Antenna Tuner is shown in Figure 4.1. C1 is a vacuum variable capacitor (7-1000pf) and is the input series element to the L network. L4 is a variable inductor (.2-18 microhenries) and is the shunt element of the "L" network. C6 consists of five 100 pf ceramic transmitting capacitors all connected in parallel and is switched in shunt with L4 when required. C3 consists of two 100 pf ceramic transmitting capacitors and is switched in series with the antenna when required. C1 and L4 are controlled by servo motors that are driven by voltages derived from the phase and amplitude detectors. The phase detector output controls the variable capacitor and the amplitude detector controls the variable inductor. C3 and C6 are switched in and out by high voltage relays, K2 and K3. Transformer T1 is a broadband transformer that transforms the tuned impedance of 12.5 ohms to 50 ohms. (Tuning to 12.5 ohms, rather than 50 ohms, greatly increases the tuning range of the elements.)

4.2 AMPLITUDE AND PHASE DETECTORS (2A4 ASSEMBLY)

The 2A4 assembly is bolted to the main chassis and is shown pictorially in Figures 6.2, 6.7, 7.7, and 7.8..

4.2.1 AMPLITUDE DETECTOR

Refer to Figure 5-1, GCU-935 Schematic Diagram. The amplitude detector provides a method of measuring the magnitude of the impedance that exists at the input to T1, the 50 ohm :12.5 ohm broadband transformer. If this magnitude is greater than 50 ohms, the output from the amplitude detector will be one polarity. If the magnitude of the impedance is less than 50 ohms, the output polarity will be reversed. Referring to Figure 5-1, 2A4, a voltage sample is derived from the line by capacitive divider C1-L1-C2. This voltage sample is rectified by CR3-R3 and produces a DC voltage proportional to the voltage on the line. A voltage proportional to the current in the line is generated by transformer 2A4T1 and is rectified in diode CR2. C1 is a variable capacitor and is adjusted so the voltage sample is exactly equal to the current sample when the detector is terminated with 50 ohms. If the magnitude of the impedance at the input to T1 is greater than 50 ohms, the voltage sample will be larger than the current sample. Under these conditions, the output voltage (measured from L6-10V REF to L4-A OUT) would be negative. If the magnitude is less than 50 ohms, the current sample is larger than the voltage sample and the output (from 10V REF to A OUT) will be positive. This output is fed to a differential amplifier located on 2A2 and generates a voltage suitable for driving the servo preamplifiers. It should be noted that the amplitude detector is floating on 10 volts and is not referenced to ground. All measurements for the amplitude detector must be referenced to the 10V reference line.

4.2.1.1 Reflected Power Detector

The amplitude detector portion of 2A4 also provides an output proportional to the reflected power on the line. This is accomplished by 2A4CR1, 2A4C4, 2A4L2, and 2A4T1. The voltage sample and the



(

(

(

current sample are added in 2A4CR1 and a DC voltage is produced between the 10V reference and the REF PWR output. The reflected power detector compares both phase and magnitude of the voltage and current samples while the amplitude detector portion compares only magnitudes. The REF PWR output is always one polarity, that is, it is always positive with respect to the 10V reference. Its output will be a minimum when the unit is correctly tuned.

The reflected power detector is important to the operation of the GCU-935 because it is used to control the operation of nearly all functions in the unit. The reflected power output from 2A4 is fed to 2A1 and amplified in a differential amplifier, 2A1U1.

4.2.2 PHASE DETECTOR

The circuitry for the phase detector is also contained in 2A4. The phase detector observes the phase of the voltage at the input to T1 and generates a DC voltage proportional to the phase error. The output of the phase detector is nulled (near zero) when the line current and the line voltage are in phase. The voltage sample for the phase detector is derived by 2A4C22, 2A4R6, 2A4C10, and 2A4C11. This voltage sample is shifted in phase 90 degrees by the differentiating action of 2A4 C22 and R6. The current sample is generated by 2A4T2 and is in phase with the line current. The voltage sample (shifted 90 degrees from the line voltage) is injected into the center tap of the current sensing transformer. The output of the transformer is detected in 2A4 CR4 and CR5 to produce a DC voltage proportional to the phase error between the voltage on the line and the current in the line. 2A4R5 is a balance control and is adjusted so the output from the phase detector is nulled when the input to T1 (50:12.5) is terminated with a 50 ohm - nonreactive load.

It should be noted that the phase detector is also floated on the 10V reference. The 10V reference is connected to one side of the phase detector and all measurements are made with respect to the 10V reference. A

capacitive load (negative phase) will cause point A of the phase detector output to go negative with respect to the 10V reference. An inductive load (positive phase) will cause point A to go positive with respect to the 10V reference. The output of the phase detector is fed to a differential amplifier on 2A2.

The phase detector is connected to the phase servo amplifier such that a positive phase angle will drive the variable capacitor toward minimum capacity while a negative phase angle will drive the variable capacitor toward maximum capacity. The amplitude detector is phased so that an impedance magnitude greater than 50 ohms will drive the variable inductor toward minimum inductance while an impedance magnitude less than 50 ohms will increase the inductance.

4.3 REGULATOR BOARD (2A3) AND FILTER BOARD (2A3A) (SEE FIGS. 5.1 and 7.6)

The Regulator Board, 2A3, regulates the 28 VDC in, down to 10V used in the 2A1, 2A2, and 2A4 boards, and to 5V used in the 2A1 and 2A2 boards. The RF detector is also located on this board and detects the presence of RF on the line. The output of the RF detector is fed to the 2A1 Control Logic Board.

The Filter Board, 2A3A, contains 12 RF chokes and 24 capacitors and is used to prevent RF pickup and radiation from being radiated from the control cable or conducted into the GSB-900. The 2A3A also provides filtering for the 28V input.

4.4 3DB ATTENUATOR (SEE FIGURES 6.1, 6.9, 7.2)

The 3dB attenuator R6, R7, R8 is controlled by relay K4 and is switched in series with the GSB-900 RF output and the input to the antenna tuner during the tune cycle. This attenuator provides protection for the GSB-900 transmitter in that it limits the impedance variations placed on the transmitter output during the tuning cycle. The attenuator is switched out just prior to the ready light coming on.

(

(

(

4.5 C3 AND C6 CONTROL (SEE FIGS. 5.1, 6.1, 7.2, 7.4)

4.5.1 C6 CONTROL

C6 is switched across the variable inductor by relay K2, a high voltage relay. K2 is controlled by a Bi-stable relay, 2A5K1. 2A5K1 is controlled by circuitry on 2A1. The basic principle of operation of C6 is as follows:

1. If, during a tuning cycle, the inductance reaches maximum, and C6 is not switched into the circuit, it is switched in. If C6 is already switched into the circuit and the inductance reaches maximum, it is switched out.
2. Every time the inductance reaches minimum, if C6 is in the circuit, it is switched out.
3. When a Tune Start pulse is initiated, if C6 is across L4, it is removed. 2A5K1 operates like a bi-stable. Each time it is toggled by a ground pulse from 2A1, it changes state. For example, if C6 is in the circuit (K2 energized) and a ground pulse is applied to 2A5K1, K2 will de-energize. Conversely, if K2 is de-energized and 2A5K1 receives a ground pulse from 2A1, K2 will energize and C6 will be switched across the inductor. In other words, if C6 is in the circuit, it will be taken out and if it is out it will be put in.

4.5.2 C3 CONTROL

C3 is switched in series with the antenna by relay K3. K3 is controlled by 2A5K2 which is controlled by the time delay circuit located on 2A1. If the capacitor is NOT needed for tuning a particular antenna, and if it is in the circuit, when the time delay runs out, it will be shorted out. If the capacitor, C3, is NOT in the circuit and if the time delay runs out, it will be put into the circuit. 2A5K2 is also a bi-stable relay and will change state for each ground pulse received from 2A1.

For most antennas and frequencies, C3 is not needed. However, with the C3 capability, the antenna tuner will tune a much wider range of antennas.

4.6 SERVO MOTOR CONTROL ASSEMBLY (2A6) (FIGURES 5.4, 6.2, 7.6, 7.7)

The 2A6 sub-assembly contains two identical servo amplifiers for driving the two DC motors for the tuning elements. The \emptyset (phase) portion drives M1 which controls the variable capacitor. The A (amplitude) portion drives motor M2 which controls the inductor. The controlling inputs to the \emptyset portion are lines D and R. When there is no drive to the amplifier from the pre-amplifier, lines D and R are at +28VDC. Therefore, Q1 and Q6 are cut off and no current is delivered to M1. If a ground is placed on line D for example, Q1 will saturate causing Q2 to deliver + voltage to line N. Q1 also saturates Q4, causing line P to be at near ground potential. Therefore, line N is + and line P is near ground and the motor M1 will rotate in one direction. If line R is grounded, Q6 will saturate causing Q5 to deliver + voltage to line P. Q6 also saturates Q3, causing line N to be near ground potential. Therefore, the motor will run in the opposite direction.

CAUTION

IF A GROUND IS PLACED ON LINE D AND LINE R AT THE SAME TIME, THE TRANSISTORS WILL BE DESTROYED.

The operation of the A servo motor control is identical to the \emptyset section.

Lines M and L are BRAKE inputs and effectively place a short across the motor when the drive is removed. This action results in less overshoot and oscillation in the system. The brake pulses are generated on 2A2.

(

(

(

4.7 CONTROL LOGIC (2A1)

See Figures 5.2, 6.5, 7.5

This plug-in module controls all the major functions in the coupler. It is composed of the following basic circuits:

1. Reflected Power Amplifier
2. Time Delay Circuit
3. Tune Bistable Multi Vibrator (BSMV)
4. Fault BSMV
5. 50 ohm BSMV
6. Lamp Drivers
7. RF Detector
8. Modulation Indicator Control
(NOT USED ON GCU-935)
9. Other Circuitry

Each of these circuits will be discussed individually.

4.7.1 REFLECTED POWER AMPLIFIER

(Logic "1" = +3 to +5 VDC)

(Logic "0" = 0 to +.5 VDC)

The reflected power amplifier consists of U1, Q1, Q2, Q3, Q4, and Q5 and associated components. The output from the reflected power detector 2A4 is fed to the input of U1, a differential amplifier. The reflected power detector output is floating on the 10V reference and U1 output, pin 10, is also at 10 VDC. U1 operates between +28 VDC and ground. Transistor Q1 emitter is referenced to 10 VDC. Therefore, when the reflected power detector has an output, pin 4 of U1 goes positive with respect to pin 5 of U1. This causes pin 10 of U1 to decrease below +10 VDC and transistor Q1 conducts. R8 is connected to the base of Q1 and is driven by the GAIN control located on the CPLR control panel in the GSB-900 (Refer to Figs. 5.5 and 7.9). The GAIN control voltage can be varied from +12VDC to +18 VDC, thereby effectively adjusting the threshold of reflected power that will cause an output from Q1.

Q2 and Q3 amplify the output of Q1. The collector of Q3 is important and is designated 50 ohm (—). When the collector of Q3 is at ground, the reflected power has dropped below the threshold and the system is correctly tuned.

Q4 drives Q5 and is a short time delay circuit. C32 can be discharged rapidly with CR3, but charges up slowly through R17. This action prevents a momentary drop in reflected power from terminating the tuning cycle. During the tune cycle, the reflected power may drop below the threshold several times for a short interval of time before finally coming to a steady condition of no reflected power.

The short time delay circuit prevents premature termination of the tune cycle. R17, in conjunction with C32, acts as a noise filter to remove sharp noise pulses. Q5 changes the 28 VDC signals in the reflected power amplifier to a logic level suitable to apply to the logic circuits. A logic "1" output from Q5 emitter terminates the tune cycle. Resistors R53 and R54 are attenuator resistors and reduce the input to the differential amplifier when the coupler is not in the tune cycle. C39 is a filter capacitor used to prevent transmitter turn on spikes from causing a fault light during normal operate mode.

The purpose of R54 is to compensate for the difference in input power level from tuning (30 watts input, attenuated to 15 watts [3db pad] into the phase and amplitude detectors) and 100 or 130 watts power during normal operate conditions. R63 and CR29 are used to disable the reflected power amplifier any time the transmitter is not keyed on.

4.7.2 TIME DELAY CIRCUIT

The time delay circuit consists of Q16, Q17, Q18, and associated circuitry. R46 is an adjustment used to set the length of the time delay, normally 40-45 seconds. When a tune cycle is initiated, the collector of Q16 rises to near 10 VDC. C40 begins charging through R47 and the voltage on the anode of Q17 increases toward 8 VDC. Q17 is a PUT (Programmable Unijunction Transistor) and will fire when the anode voltage reaches the voltage applied to the gate. R50 and R49 divide the 10 VDC down to approximately 8 volts.

When Q17 fires, a pulse is generated across R48. This positive pulse saturates Q18. The collector of Q18 drops to ground and CR21 re-sets the TUNE BSMV while CR20 re-sets the fault BSMV. This

(

(

(

action terminates the tune cycle and turns on the FAULT light. CR26 (through U2C and Q6), places a logic 0 on the L max line when the time delay fires. This action is required to terminate the L4 force function at the end of the time delay.

4.7.3 TUNE BSMV

This BSMV (toggle) consists of U3B and U3C, R33, and R34. C35, along with R25 and R26, provide sufficient loading on pin 6 to assure that the TUNE BSMV will come on with logic 0 on pin 6 when the unit is first turned on. When a TUNE pulse (+28 VDC or +10 VDC) is applied to pin A the anode of CR17, Q15 is saturated and diode CR18 turns on the TUNE BSMV by grounding pin 8 of U3. Pin 6 of U3 now has a logic 1 and Q9 and Q10 are saturated. Q9 causes the TUNING light to be illuminated while Q10 places a ground on the interlock line and the transmitter is keyed on in AM.

The TUNE BSMV is re-set at the end of the tune cycle by a logic output from U4C pin 8. U4C is an AND gate that produces a logic 0 output when RF is present and when the emitter of Q5 is at logic 1. (The emitter of Q5 will be logic 1 when the reflected power has fallen below the threshold.) In other words, the TUNE BSMV is re-set when RF is present and the reflected power drops below the threshold.

4.7.4 FAULT BSMV

The FAULT BSMV consists of U4A and U4B, R35 and R36. When the unit is initially turned on, C41 causes U4 pin 6 to be logic 0. Pin 3 of U4 is logic 1 and drives Q12 to saturation through R28.

The resulting ground through Q12 causes the FAULT lamp to be illuminated. The FAULT BSMV is reset by U4 pin 8, logic 0, which signals the tuned condition. The FAULT BSMV is also set by U5A pin 11, logic 0. U5A is a NAND gate that has a logic 0 output when there is reflected power present (Q3 collector logic 1) and the tuner is not in the TUNE mode (U3 pin 8, logic 1). This feature allows the FAULT light to come on any time the antenna changes or the frequency has been changed without tuning the antenna tuner. Diode CR25 resets the 50 ohm BSMV and saturates Q14, causing the 3DB pad to be switched into the RF

path. This action assures a 50 ohm load for the transmitter when the reflected power exceeds the threshold. As mentioned previously, the time delay will also set the FAULT BSMV with a logic 0 applied to the cathode of CR20. CR9 resets the FAULT BSMV (fault light off) during the tune mode.

4.7.5 50 OHM BSMV

The 50 OHM BSMV is contained in U6C and U6D. R38 and R39 are cross coupling resistors to make the two gates a latch. The purpose of the 50 OHM BSMV is to control the 3DB attenuator relay. When a TUNE pulse initiates a tuning cycle, diode CR15 pulls U6 pin 8 to logic 0. This causes logic 1 on pin 11 of U6, causing R40 to saturate Q14. When the collector of Q14 is at ground, the pad relay is energized and the 3DB attenuator is switched between the transmitter output and the 50:12.5 ohm transformer. When RF power is present at the input of the coupler (logic 1 on pin 3 of U3) and when the reflected power is below the threshold (logic 0 on the collector of Q3, logic 1 on pin 3 of U6) logic 0 will be present on pin 6 of U6. This logic 0 sets the 50 OHM BSMV and switches the 3Db attenuator out of the RF path, allowing the coupler to tune on full RF power during the last few milliseconds of the tune cycle.

There are some frequency impedance combinations that will cause the 50 OHM BSMV to be set and the tuner will not tune. When this occurs, after a few milliseconds, R29-C36 time constant will charge up to logic 1 and Q13 collector will drive U6 pin 13 to logic 0. When this occurs, the 50 OHM BSMV is re-set and the 3Db attenuator is again switched into the circuit. In other words, if the reflected power does not stay below the threshold, the pad will be switched in again. This action is required to prevent transmitting into an open or short circuit.

4.7.6 LAMP DRIVERS

The three tuner status lamps, located on the coupler control panel, are controlled by Q9, Q11 and Q12. These light drivers are saturated by the logic circuits at the appropriate time. The FAULT light driver is Q12 and is saturated (collector at ground) anytime the FAULT BSMV is set (logic 1 on pin 3 of U4). The READY light is driven by Q11 and is saturated by pin 11 of U4. This will

(

(

(

occur when the tuning cycle is complete and the unit is ready to use. The TUNING light is controlled by Q9 and it is saturated any time the TUNE BSMV is set (logic 1 on pin 6 of U3).

4.7.7 RF DETECTOR

Q8 generates a logic 0 on its collector when RF is present at the input of the coupler. 2A3R2, CR1 and CR2 detect the RF from the transmitter and generate a DC output. This output is fed to R23 and saturates Q8. R23 and C34 delay the time of saturation of Q8 and prevent RF signal perturbations from turning the tuner off when the transmitter is first keyed on.

4.7.8 OTHER CIRCUITRY

Q19, R57, R58, and R59 are used to cause the Pad relay (3DB attenuator) to be energized any time the antenna coupler is in a tuning cycle and there is no RF present. This condition can occur if a tuning cycle is initiated and the frequency of transmission is changed. When the transmitter is keyed on again after the frequency change, the Pad relay is pulled in and the transmitter will see a 50 ohm load rather than an open or a short. The Pad relay is pulled in by the action of U5C and diode CR27. If the coupler is in a tune mode, a logic 1 appears on pin 6 of U3 and also on pin 1 of U5. If no RF is present, a logic 1 will appear on the collector of Q19 and pin 2 of U5. When a logic 1 appears on pin 1 and pin 2 of U5, a logic 0 appears on pin 3 of U5, causing a logic 0 on pin 13 of U6, via CR27. This logic 0 on pin 13 of U6 causes Q14 to saturate and the Pad relay pulls in.

Capacitors C1 through C24 and C25, C44, C45, C48, C50, C51, C52 and C53 are RF bypasses to prevent RF on the wiring from entering the PC board and disturbing the operation of the logic circuits. C26, R2 and R1 provide filtering between the reflected power detector and the input to the differential amplifier, U1. R5, C27 and C28 provide filtering on the 28 volt line for the amplifier U1. R4, C29 and C30 are feedback networks to stabilize the operation of U1. R3 is the negative feedback resistor and determines the gain of U1. R6 is an isolation resistor from pin 10 of U1 and the base of Q1. C31 increases the AC gain of the reflected power amplifier. CR1 and R7 reduce the gain of the reflected power amplifier when the interlock line is at 10 volts. (When the unit is in the receive mode the interlock line rises to 10 volts.) CR22 and R8 set the threshold of the reflected power amplifier and connect to the gain control potentiometer on the coupler control panel. R9 is an isolation resistor for the emitter of Q1, while R10 and R11 divide the output of Q1 down to a voltage suitable to drive the base of Q2. R13 is the collector load for Q2 and R14 is the drive resistor to the base of Q. R15 is the collector load for Q3 and R16 is the collector load for Q4. R55 is a bias resistor for pin 9 of U2. R41 and R43 form a divider to the base of Q15 while R42 is the collector load for Q15.

4.7.9 DIODE FUNCTION LIST

Since diodes are used for logic functions, it is important to indicate the purpose of the diodes used on 2A1. The following Table lists the diode, the major line and its specific function.

| DIODE | LINE | FUNCTION |
|-------|----------------------|---|
| CR22 | GAIN | Isolates the gain voltage, supplied by the GAIN control from the base voltage of Q1. |
| CR1 | Interlock | Isolates Q1 base voltage from the collector of Q10 when Q10 is saturated. |
| CR2 | Base of Q4 | This zener diode (3.6V) isolates the base of Q4 from the collector of Q3 and allows the collector to rise to a logic 1 level. |
| CR3 | Collector of Q4 | CR3 allows for the fast discharge of C32 when the reflected power rises to above the threshold. |
| CR5 | CPLR TUNE | CR5 is used to discharge C32 during the interval of the CPLR TUNE pulse. This prevents C32 from having a logic 1 immediately after the CPLR TUNE pulse and shutting off the unit prematurely. |
| CR7 | CPLR TUNE | CR7 generates a logic 0 on the C1 Home line and sets the C1 Home BSMV on 2A2. |
| CR8 | CPLR TUNE | CR8 generates a logic 0 on the L4 Home line and sets the L4 Home BSMV on 2A2. |
| CR10 | 50(-) | Allows the fast discharge of C36 so the Pad relay can drop out fast when a 50 ohm impedance has been found. |
| CR9 | Pin 3 of U4 | When the TUNE BSMV is set, CR9 turns off the fault light and resets the Fault BSMV. |
| CR12 | SW10V | Prevents the negative going edge of this voltage from generating a spike. |
| CR13 | C38 and R32 junction | This zener diode prevents a positive spike greater than 5 volts. |
| CR11 | Not Used | |
| CR16 | Lmax | This diode forces the Pad relay to pull in when the inductor reaches maximum inductance. It is required to prevent the coupler from locking up at certain impedance - frequency combinations. |

Table 4.1 Diode Function List, 2A1

(

(

(

| DIODE | LINE | FUNCTION |
|-------|--|---|
| CR15 | CPLR TUNE | Forces the Pad relay to pull in when a tuning cycle is initiated. |
| CR17 | CPLR TUNE (Pin A) | Isolates the CPLR TUNE input from the base of transistor Q15. |
| CR18 | CPLR TUNE | CR18 sets the tune BSMV when a tune cycle is started. |
| CR19 | Anode of Q17 | Rapidly discharges C40 when a tune cycle is ended. |
| CR20 | Collector of Q18 (Time Delay) | Sets the Fault BSMV when the time delay runs out and causes the Yellow Fault light to be illuminated. |
| CR21 | Collector of Q18 | CR21 re-sets the Tune BSMV when the time delay runs out. |
| CR14 | U5 pin 8 | CR14 sets the Fault BSMV when SW10V is applied to 2A1. |
| CR23 | U5 pin 6 | CR 23 re-sets the Tune BSMV when nominal 28V is applied to 2A1, if the coupler is in the tune mode (Tune BSMV is set). |
| CR24 | U5 pin 6 | Sets the Fault BSMV when 28V Nom is switched to 2A1, if the unit is in the tune mode. |
| CR27 | U5 pin 3 | If, during a tune mode, the collector of Q19 goes to a logic 1 (indicating no RF input), CR27 causes a logic 0 on pin 13 of U6, pulling the Pad relay in. |
| CR25 | U5 pin 11 | If the coupler is NOT in a tune mode (logic 1 on pin 12 of U5) and the reflected power exceeds the threshold (logic 1 on pin 13 of U5), U5 pin 11 will have logic 0 and CR25 will cause the Pad relay to pull in. |
| CR26 | Collector of Q6 Function (Time Delay) | If the time delay runs out while L4 is being forced toward maximum L, CR26 places a logic 0 on the Lmax line and terminates the force function. |
| CR6 | Not Used | |

Table 4.1 Diode Function List, 2A1 (Continued)

4.8 PHASE AND AMPLITUDE CONTROL (2A2)

Figures 5.3, 6.5, 7.5

This plug in module contains all the circuitry to control the servo motors that drive the variable tuning elements, C1 and L4. The following major functions are contained on the board:

1. Phase Preamplifier (U1)
2. Amplitude Preamplifier (U3)
3. Phase and Amplitude Level Changer
4. Positive and Negative Phase Detectors
5. Greater than 50 Ohm and Less than 50 Ohm Detectors
6. Lmin-Cmax Gate
7. Positive and Negative Phase Drivers
8. Greater than and less than Drivers
9. Lmin, 0 Phase, Greater than 50 Ohm Detector
10. Positive Phase, Greater than 50 Ohm Detector
11. C1 Home BSMV
12. L4 Home BSMV
13. L4 Force BSMV
14. Phase Shorting Switch
15. Amplitude Shorting Switch
16. Brake Circuit
17. Lmin Pulse Reversing Circuit
18. Lmax Reversing Circuit
19. Other Components

Each of these functions will be discussed in later paragraphs.

4.8.1 GENERAL OPERATIONS OF THE PHASE AND AMPLITUDE CONTROL BOARD

The phase and amplitude detectors, along with the reflected power detector, are constantly monitoring the input to the tuning elements. The 50:12.5 Ohm transformer transfers the impedance at the input to C1 (12.5 ohms) to 50 Ohms when the unit is tuned. The Phase preamplifier and the positive and negative phase drivers control the servo amplifier in such a manner that when the phase is positive, C1 decreases in value (less pf) and when the phase is negative, it increases in capacitance. The amplitude preamplifier, along with the greater than 50 ohm and the less than 50 ohm drivers,

controls the amplitude servo to drive the inductor L4 toward minimum inductance for an amplitude greater than 50 ohms and toward maximum inductance for an amplitude less than 50 ohms. Both the phase and the amplitude servos are closed loop but are interrupted for various functions while the closed loop tuning is in progress.

The 50(-) and the 50(+) lines are two control lines from the control logic board (2A1) and signify that the reflected power has dropped below the threshold. The 50(-) line has a negative pulse (logic 0) while the 50(+) line has a logic 1 to signify that the reflected power is below the threshold. During a tuning cycle, when the reflected power drops to below the threshold, the 50(+) line drives through diodes CR8 and CR25 to short out the drives to both phase and amplitude drivers to effectively remove the drive to both servo motors. Q8 generates a brake pulse for both the phase and the amplitude servo amplifiers. The action of the 50(-) and the 50(+) lines effectively removes the drive and applies a brake pulse to both servos, even if there is a phase error or an amplitude error present. (A small phase and amplitude error could exist while the reflected power would be below the acceptable threshold.)

During the tuning cycle, certain combinations of events are monitored and, when these occur, are used to control other functions. The following combinations of events are detected:

1. When the phase is positive and the magnitude is greater than 50 ohms.
2. When the inductor is at minimum, the phase error is zero, and the amplitude is greater than 50 ohms.
3. When the inductor is at minimum and the capacitor is at maximum.

When a tuning cycle is initiated, the C1 Home BSMV begins driving the variable capacitor toward maximum capacity and the L4 Home BSMV begins driving the inductor toward minimum inductance. This method of homing is required in order to force the phase positive so tuning can be accomplished and the unit will not lock up at certain impedance-frequency combinations. The homing of both elements is stopped as soon as the phase is positive and the amplitude is greater than 50 ohms.

(

(

(

Since the homing functions are driving the elements toward minimum L and maximum C, as soon as the amplitude error voltage becomes the same polarity as the homing voltage and the phase becomes positive, the homing function can be turned off and the tuning can be accomplished in a shorter time. (Greater than 50 ohms drives the L toward minimum, and positive phase drives the capacitor toward minimum, so further homing of the capacitor would result in longer tuning time.)

When the inductor is at minimum, the phase error zero and the magnitude is greater than 50 ohms, the coupler would hang up if it weren't for a detection circuit (second event). Since the magnitude is greater than 50 ohms and the inductor is at minimum L, the inductor would just remain stationary (greater than 50 ohms drives the L toward minimum) and the capacitor would also remain stationary since there is no phase error.

The third event mentioned is for Lmin and Cmax. This condition is detected in U5 pin 6 and is connected to 2A5 where it is compared with the status of C3, the capacitor placed in series with the antenna. If the condition of Lmin and Cmax exists, and if C3 is not in the home position, then the next step of C3 is inserted. This action reduces tuning time.

The L4 Force BSMV is set by the condition of Lmin and Cmax. This condition can occur when tuning certain antennas from a high frequency, such as 20 MHz and then moving to 2 MHz. The capacitor will run to maximum because of the home function and the inductor will run to minimum. However, at this time, the phase will be negative and the magnitude will be greater than 50 ohms and both elements would remain stationary if it were not for the L4 Force BSMV. The L4 Force BSMV will force the L toward maximum inductance until the phase becomes positive and then normal tuning will take over. The L4 Force BSMV is re-set by the condition of positive phase and amplitude greater than 50 ohms.

The servo amplifier is controlled by transistors Q6 and Q7 for phase drive and Q13 and Q14 for amplitude drive. During the normal tuning portion of the tune cycle, when there is no Home. Force. Lmin, Lmax, Cmin, or Cmax conditions, the level changers drive Q6, Q7, Q13 and Q14 in a normal

closed loop manner. These drives are interrupted or removed from the servo driver transistors as shown below:

- Q6 Positive Phase Driver - This transistor has only one source of input, the positive phase error from the phase level changer.
- Q7 Negative Phase Driver - This transistor has two sources of drive. One is from the negative phase error voltage from the phase level changer (R23) and the C1 home drive (R22).
- Q13 Less than 50 Ohm Driver - The error voltage from the amplitude level changer is fed to the base through R60. The L4 force drive is applied through R61. CR41 applies a pulse to force the inductor off Lmin.
- Q14 Greater than 50 Ohm Driver - The L4 Home drive is applied through R57 and the error voltage from the amplitude level changer is fed to the base via R58. R76 supplies a drive voltage to force the inductor off the Lmax switch when it reaches maximum L.

4.8.2 PHASE PREAMPLIFIER (U1)

The phase preamplifier is contained in U1 and associated circuitry. The output from the phase detector is floating about +10 VDC and is fed to pin 4 and 5 of U1. This circuit is a differential amplifier and if pin 5 goes positive with respect to pin 4, the output, pin 10, will rise above +10VDC. (The differential amplifier operates between +28 VDC and ground; pin 10 is at +10VDC with no input between pins 4 and 5). The input to the differential amplifier is very small at null (voltage and current in phase), but rises to ± 1 volt while tuning.

Diodes CR1 and CR2 are used to protect the input of the differential amplifier from excessive inputs from the phase detector. C23, along with R1 and R2, filters noise pulses from the input. R3 and C22 provide filtering for the 28 volts to the amplifier. R4 and C24, along with C25, provide feedback to stabilize the frequency response of the amplifier. R5 is a negative feedback resistor to limit the gain of the amplifier. R6 is an isolation resistor to the input of the level changer, Q1 and Q2.

(

(

(

4.8.3 AMPLITUDE PREAMPLIFIER (U3)

The amplitude preamplifier consists of U3 and associated components. The operation of the amplitude preamplifier is exactly the same as the phase preamplifier, except the amplitude preamplifier has more gain. This is accomplished by making the feedback resistor (R45) larger than for the phase preamplifier. The output of the amplitude preamplifier (pin 10) is also floating about +10 VDC and must be shifted in a level changer.

R41, 42, 43, 44, and 46 perform identical functions as in the phase preamplifier. C27, 28, 29 and 30 also perform the same functions as in the phase preamplifier. CR20 and CR21 protect the amplifier from over load.

4.8.4 PHASE AND AMPLITUDE LEVEL CHANGER

The phase level changer consists of Q1, Q2, Q3 and associated components. A positive phase angle will cause U1 pin 10 to rise above +10 VDC. This action will cause transistor Q1 to conduct (its emitter is referenced to +10 VDC). When Q1 conducts, the voltage drop across R11 causes Q3 to conduct. When Q3 conducts, a positive voltage appears on the collector. This voltage supplies the drive for the servo preamplifier for a positive phase angle.

If the output voltage of the phase preamplifier drops below +10 VDC (the condition for a negative phase angle) Q2 will conduct and a positive voltage will appear on the collector of Q2. This voltage is the drive voltage for the phase servo preamplifier for a negative phase angle. The amplitude level changer consist of Q10, Q11 and Q12. It operates identically to the phase level changer. R47 is the collector load for Q10 while R9, 10, 48, and 49 are isolation resistors that provide degeneration for Q1, 2, 10, and 11. R12 and R51 provide degeneration for Q3 and Q12, respectively.

4.8.5 POSITIVE AND NEGATIVE PHASE DETECTORS

A positive phase is detected when a logic 1 appears across R14. R13 divides the output of Q3 to a logic 1 level. This signal is fed to pin 9 of U2 and compared with the greater than 50 ohm logic input

on pin 10. When both are logic 1, a logic 0 appears on pin 8 of U2. The logic 1 across R14 also saturates Q4 thru R70. Q4 collector will rise to logic 1 when the phase error is zero (provided the amplitude is greater than 50 ohms, L is at minimum, and C is not at maximum). A negative phase angle appears as a positive voltage across R67. R7 divides Q2 output down to approximately 1 volt. If the phase error is zero, Q4 or Q18 will not be saturated.

4.8.6 GREATER THAN 50 OHMS AND LESS THAN 50 OHM DETECTOR

The greater than 50 ohm signal is divided by R50 and appears across R68 as a logic 1. Less than 50 ohms is divided by R52 and appears across R69. If the amplitude error is greater than 50 ohms or zero, Q19 will not be saturated.

4.8.7 LMIN-CMAX GATE

When the inductor is at minimum L and the capacitor is at maximum C, these logic 0 inputs are fed to U5 pin 10 and pin 13, respectively. The logic 0's are inverted to logic 1's in U5C and U5D and are compared in U5B. When U5 pin 4 and pin 5 are both logic 1, pin 6 is logic 0 and indicates the condition of Lmin-Cmax. This is used to set the L4 Force BSMV U4C and D and is fed to 2A5 on pin D.

4.8.8 POSITIVE AND NEGATIVE PHASE DRIVERS

These two transistors, Q6 for positive phase and Q7 for negative phase, are used to drive the phase servo bridge. R26 and R28 are used for degeneration for the devices. R16 and R25 couple the positive phase drive from Q3 collector. When the collector of Q6 is less than 28 volts, the servo motor will run in a direction to decrease the capacitance. When the collector of Q7 is less than 28 volts, the phase servo will run in a direction to increase the capacitance. R8 and R23 couple the drive from Q2 collector.

4.8.9 GREATER THAN AND LESS THAN DRIVERS

Q13 is the amplitude driver for an amplitude less than 50 ohms. Q14 is the amplitude driver for an

amplitude greater than 50 ohms. If the collector of Q13 is less than 28 volts, the servo motor will run in a direction to increase the inductance. If the collector of Q14 is less than 28 volts, the servo motor will run in a direction to decrease the value of inductance. R53 and R60 couple the less than 50 ohm drive from Q12 collector. R54 and R58 couple the greater than 50 ohm drive from the collector of Q11.

4.8.10 LMIN, 0 PHASE, GREATER THAN 50 OHM DETECTOR

This detector consists of transistors Q4 and Q18 (for zero phase) and Q19 for greater than 50 ohms. These three transistors operate into a common collector load, R15, and the collectors will rise to logic 1 when all three transistors are cutoff.

Diode CR34 prevents the collectors from rising to a logic 1 unless a logic 0 is on the Lmin line. The logic 1, indicating Lmin, 0 phase, and greater than 50 ohms, appearing on the collectors of Q4, 18, and 19, is fed through R71 to the base of Q17 and is inverted to a logic 0. R72 is the collector load for Q17. This logic zero is fed to the 2A5 board on pin E. This control signal causes circuitry on 2A5 to switch a value of C3 in series with the antenna.

CR33 inhibits the Lmin, 0 phase, greater than 50 ohm function when the capacitor is at Cmax. CR19 prevents a logic 1 from appearing on Q4 collector while C1 is being homed.

4.8.11 POSITIVE PHASE AND GREATER THAN 50 OHM DETECTOR

This function is accomplished by recognizing a positive phase and a magnitude greater than 50 ohms. The positive phase is detected by a logic 1 across R14. This logic 1 is fed to gate U2D pin 9. Greater than 50 ohms appears as a logic 1 across R68 and is fed to gate U2D pin 10. A logic 0 results on U2D pin 8. Diode CR15 terminates the L4 Home BSMV, CR16 terminates the L4 Force BSMV and the logic 0 input to pin 5 of gate U2B terminates the C1 Home BSMV.

4.8.12 C1 HOME BSMV

The C1 Home BSMV (toggle or latch) consists of U2 gates A and B and cross coupling resistors R17 and R18. C26 is a delay capacitor to assure that U2 pin 3 will be a logic 0 when power is first applied

to the circuit. When a Tune pulse is initiated, a logic 0 appears on the C1 Home line and a logic 1 appears on pin 3 of gate U2A. This logic 1 is fed through R22 to the base of Q7 and the variable capacitor is forced to run toward Cmax. This forcing of C1 will continue until Cmax is reached or the phase becomes positive and the magnitude is greater than 50 ohms. Cmax logic 0 will stop the C1 home through CR7 while positive phase and magnitude greater than 50 ohms will terminate the home function with the logic 0 on pin 5 of gate U2B. When the C1 Home BSMV is set (logic 0 on pin 6 of U2B), a logic 1 appears on pin 11 of gate U2C. This output saturates Q5 through R19.

Diodes CR9 and 10 short out any drive that might be coming from the phase level changers. This action is required to prevent turning on both sides of the phase servo at the same time. The C1 Home logic 0 input to pin 13 of gate U2C also shorts out any drive that may come from the phase level changers to prevent the capacitor from moving during the duration of the Tune pulse. This action is required to prevent the capacitor from moving if the unit is already tuned.

4.8.13 L4 HOME BSMV

The L4 Home BSMV consists of U4 gates A and B and cross coupling resistors R31 and R32. Capacitor C32 is a time delay capacitor to assure that pin 3 of U4 will be a logic 0 when power is first applied to the board. When a Tune pulse is initiated, a logic 0 appears on the Home L4 line. This causes a logic 1 on pin 3 of U4 gate A. This logic 1 drives the base of Q14, the greater than 50 ohm driver, through CR35 and R57. This action causes the inductor to run toward the homed position - Lmin. The L4 Home drive can be turned off by a positive phase-greater than 50 ohm logic 0 through CR15. If the inductor reaches Lmin, a logic 0 on the Lmin line will turn off the L4 Home drive through CR17.

4.8.14 L4 FORCE BSMV

The L4 Force BSMV consists of U4 gates C and D and cross coupling resistors R33 and R34. C31 is a time delay capacitor to assure that U4 pin 8 will be logic 0 when power is first turned on. The L4 Force BSMV is turned on only when Lmin and Cmax occur simultaneously. When this condition occurs, a logic 0 output from pin 6 of U5 gate B causes pin 8

(

(

(

of U4 to become a logic 1. This logic 1 is fed through CR39 and R61 to the base of Q13, the less than 50 ohm driver. This action forces the inductor to run toward maximum inductance.

This action is required for some frequency-impedance combinations when the capacitor is maximum and the inductor is minimum but the magnitude is still greater than 50 ohms. The L4 Force function is terminated by a positive phase and greater than 50 ohm condition through CR16. Pin R is shorted to logic 0 by circuitry on 2A5 to inhibit the L4 force function when Lmin-Cmax occurs and C3 is not in the home position.

4.8.15 PHASE SHORTING SWITCH

Q5, in conjunction with CR9 and CR10, shorts out the drive from the positive phase driver and the negative phase driver. This action is required when the C1 Home BSMV is set or when a Tune pulse is initiated. When the C1 Home BSMV is set, drive is supplied to the base of Q7. If the phase were positive, drive would be supplied to the base of Q6 and both sides of the servo would be turned on at the same time. Therefore, the shorting switch shorts out the positive phase drive (if it occurs) and prevents this from happening.

When a Tune pulse is initiated, a logic 1 is forced to appear on the 50(+) line by circuitry on 2A1. This logic 1 is fed to the base of Q5 through CR8 and R21, causing both positive and negative drive to be shorted out. This action is required because if the coupler is already tuned, it prevents the capacitor from moving during the interval of the Tune pulse, and results in a faster tune. R24 provides the back bias for diodes CR9 and CR10.

4.8.16 AMPLITUDE SHORTING SWITCH

Q15, along with CR26 and CR27, shorts out the drive from the amplitude drivers Q13 and Q14. The greater than 50 ohm and the less than 50 ohm drive must be shorted out when either the L4 home BSMV is set, L4 Force BSMV is set or a Tune pulse is initiated. When the L4 Home BSMV is set, the base of Q14 is driven so the inductor will be driven toward minimum L. If the amplitude error is less than 50 ohms, Q13 would also be turned on, resulting in both sides of the L4 servo being turned on at the same time. Q15 prevents this by shorting out both drive voltages. When the L4 Force BSMV is set, the base of Q13 is driven and

if the amplitude error is greater than 50 ohms, then Q14 would also be turned on.

Q15 also prevents this from occurring. If either the L4 Home BSMV or the L4 Force BSMV are turned on, U5 gate A will have a logic 1 output that will saturate Q15 through R55. When a Tune pulse is initiated, the logic 1 on the 50(+) line saturates Q15 through CR25 and R56. This action prevents the inductor from moving during the interval of the Tune pulse and results in a faster tune. R59 provides the back bias for diodes CR26 and CR27.

4.8.17 BRAKE CIRCUIT

Each time the reflected power drops below a predetermined threshold, a brake pulse is generated in order to reduce the gain of both servo amplifiers and dampen oscillation. The 50(+) line has a logic 1 each time the reflected power is below the threshold while the 50(-) line has a logic 0. Q8 and R36 form an emitter follower circuit that provides current gain for the pulse. The brake diodes in the servo amplifier are driven through R37. R78 is a voltage dropping resistor that prevents excess dissipation in Q8.

4.8.18 LMIN PULSE REVERSING CIRCUIT

C35, CR40, CR41, and R38 generate a pulse each time the inductor reaches Lmin. When the Lmin switch closes, a logic 1 is generated on pin 8 of U5. This pulse is differentiated in C35. The negative spike is clipped by CR40 and the positive portion is fed to the base of Q13 by CR41. If the inductor is being driven toward Lmin at a fast speed, some means must be provided to stop it or it will hit the end stop. While the inductor is being driven, Q14 is being driven by a greater than 50 ohm error signal or by the L4 Home BSMV. When Lmin is reached, CR23 removes the error voltage drive and CR17 terminates the L4 Home function. At the same time, the Lmin Pulse Reversing Circuit reverses the drive on the inductor for the duration of the pulse. This is effective in stopping the inductor and preventing it from hitting the end stop.

4.8.19 LMAX REVERSING CIRCUIT

This circuit consists of CR37, R73, R74, R75, Q20, CR36 and R76. When L4 is being driven toward Lmax, whether by error voltage (less than 50 ohms) or by the L4 Force BSMV, it has to be stopped rapidly to prevent hitting the end stop and

(

(

(

must be forced off Lmax. It must be forced off Lmax because the Lmax signal is used on 3A4 to switch in C6 capacitors across the antenna. If the inductor were allowed to close the Lmax switch and keep it closed, the C6 capacitor drive motor would continually run. Therefore, an Lmax logic 0 applied to the cathode of CR37 cuts off Q20 and its collector rises to a logic 1 and drives the base of Q14 through CR36 and R76. Since Q14 is the greater than 50 ohm driver, the inductor will be forced toward Lmin until the inductor roller is no longer contacting the Lmax switch. R73 provides a logic 1 bias for the Lmax line. R74 saturates Q20 when there is no Lmax signal. R75 is the collector load for Q20. CR24 shorts out the drive to Q13 when Lmax is reached.

4.8.20 OTHER COMPONENTS

R30 supplies a logic 1 bias for the Lmin-Cmax line. R29 supplies the logic 1 bias for the L4 Home BSMV. R35 supplies a logic 1 bias for the Lmin line. R77 supplies a logic 1 bias for the Cmax line. CR18 is an isolation diode between the Lmin line and pin 10 of U5. Capacitors C1-C13, C34, etc. are rf bypass capacitors to prevent rf on the wires from disturbing the logic functions on the PC board.

4.8.21 DIODE FUNCTION LIST

The following Table lists the diodes on 2A2 and their function.

| DIODE | LINE | FUNCTION |
|-------|------------------------------------|--|
| CR5 | Cmin | Removes the drive voltage from the positive phase driver when the capacitor reaches minimum C to prevent turning on both sides of the servo amp at the same time. |
| CR4 | Cmin | Sets the C1 Home BSMV to force the capacitor toward maximum C when the Cmin switch closes. |
| CR8 | 50(+) | Drives R21 to saturate Q5 and remove the drive from the phase drivers when the reflected power drops below the threshold. |
| CR25 | 50(+) | Drives R56 to saturate Q15 and remove the drive from the amplitude drivers when the reflected power drops below the threshold. |
| CR19 | Lmin 0 ϕ , greater than 50 | Prevents the Lmin, 0 ϕ , greater than 50 ohm function from occurring when the C1 Home BSMV is set. |
| CR11 | 50(-) | Shorts out the drive to the negative phase driver when the reflected power drops below the threshold. If the antenna coupler is tuned to a frequency that requires no auxiliary C3 or C6, and a tune cycle is initiated, both elements would begin homing. However, since when the transmitter is turned on, a logic 0 exists on the 50(-) line (coupler already tuned), CR11 prevents the capacitor from moving and lets the green light come on immediately. |
| CR30 | 50(-) | This diode shorts out the drive to the greater than 50 ohm amplitude driver for the same reason as CR11. CR30 prevents the inductor from moving when a tune cycle is initiated and the coupler is already tuned. |

Table 4.2 Diode Function List, 2A2

(

(

(

| DIODE | LINE | FUNCTION |
|-------|---|--|
| CR17 | Lmin | When the inductor reaches minimum L and the Lmin switch closes to ground, CR17 resets the L4 Home BSMV. |
| CR23 | Lmin | CR17 removes the drive from the L4 Home BSMV when the inductor reaches Lmin, but there could be drive from the greater than 50 ohm level changer (if the amplitude of the impedance is greater than 50 ohms). CR23 shorts out any drive that could be present on R58 from the greater than 50 ohm level changer. |
| CR12 | Home L4 | If a tuning cycle has been initiated and the L4 Force BSMV is set and ANOTHER tune pulse is initiated, the L4 Home BSMV will also be set. This action would cause drive to both amplitude drivers and the amplitude servo amplifier would have both sides turned on and could destroy the transistors. CR12 resets the L4 Force BSMV each time a tuning cycle is initiated, thereby preventing this double drive condition from occurring. |
| CR7 | Cmax | When the variable capacitor reaches maximum C, and the Cmax switch closes to ground, CR7 resets the C1 Home BSMV and removes the drive from R22 at the base of Q7, which had driven the capacitor toward maximum. |
| CR6 | Cmax | If there is error voltage from the negative phase level changer after CR7 has reset the C1 Home BSMV, CR6 will short out this drive. |
| CR33 | Cmax | CR33 forces a logic 0 on the Lmin, 0 phase, and greater than 50 ohm line (Collectors of Q4, Q18, Q19) to inhibit these functions with the capacitor at maximum. |
| CR24 | Lmax | When the L4 Force BSMV is set by Lmin-Cmax combination, the inductor is driven toward maximum L by the drive from R6i. When the inductor reaches Lmax and the Lmax switch closes to ground, CR24 shorts out the drive to the base of Q13, but does not reset the L4 force function. |
| CR22 | 50(-) | CR22 turns off the L4 force function anytime the reflected power drops below the threshold. |
| CR37 | Lmax | CR37 places a logic 0 on the base of Q20 and generates a drive voltage to force the inductor off the Lmax switch. When the inductor moves off the Lmax switch, the drive is removed. |
| CR15 | Positive Phase and Greater than 50 ohms | When the phase becomes positive and the amplitude is greater than 50 ohms, CR15 resets the L4 Home BSMV. |

Table 4.2 Diode Function List 2A2

(

(

(

| DIODE | LINE | FUNCTION |
|-------------------|--|--|
| CR16 | Positive Phase and Greater than 50 ohms | CR16 resets the L4 Force BSMV, if it is set, when the phase becomes positive and the amplitude is greater than 50 ohms. |
| CR3 | C1 Home | When the C1 Home BSMV is set drive is applied to Q7 through R22. If the phase is positive, drive would also be applied to Q6 through R25, CR3 shorts out this drive during the interval of the C1 Home logic 0 pulse to prevent drive to Q6 and Q7 at the same time. |
| CR9 | Collector of Q5 | Shorts out the drive to Q6 when the reflected power is less than the treshold. |
| CR10 | Collector of Q5 | Shorts out the drive to Q7 when the reflected power is less than the threshold. |
| CR26 | Collector of Q15 | Shorts out the drive to Q13 when the reflected power is less than the threshold. |
| CR27 | Collector of Q15 | Shorts out the drive to Q14 when the reflected power is less than the threshold. |
| CR35 | U4, pin 3 | CR35 isolates the drive from the collector of Q20 from pin 3, U4. |
| CR36 | Collector of Q20 | CR36 isolates the drive from pin 3 of U4 from the collector of Q20. |
| CR34 | Lmin, 0 phase, Greater than 50 ohms | When the inductor is at minimum L the logic 0 is inverted in U5C to a logic 1 and allows the Lmin, 0 phase, greater than 50 ohm line to rise to logic 1. |
| CR1 | Input of U1 | Protective diode to prevent overvoltage on pins 4 and 5. |
| CR2 | Input of U1 | Protective diode to prevent overvoltage on pins 4 and 5. |
| CR20 | Input of U3 | Protective diode to prevent overvoltage on pins 4 and 5. |
| CR21 | Input of U3 | Protective diode to prevent overvoltage on pins 4 and 5. |
| CR40 & CR41 | Base of Q13 | CR40 and CR41 form a voltage doubler circuit to generate a positive pulse on the base of Q13 when the inductor reaches minimum. Lmin is inverted to a logic 1 in U5, pin 8 and differentiated in C35. This action is required to prevent the inductor from hitting the end stop when it is driven by a home function and reaches Lmin before the variable capacitor reaches maximum. |

Table 4.2 Diode Function List, 2A2 (Continued)

(

(

(

| DIODE | LINE | FUNCTION |
|-------|------------------------------------|--|
| CR18 | Lmin | Isolates the Lmin line from pin 10 of U5. |
| CR19 | \emptyset , greater than 50 ohms | Prevents this function when the C1 Home BSMV is set. |
| CR39 | U4, pin 8 | Isolates the L4 Force drive from the base of Q13. |

Table 4.2 Diode Function List, 2A2 (Continued)

4.9 TYPICAL TUNING SEQUENCE

Before a tuning cycle can be started, the MODE switch on the front panel of the GSB-900 must be switched either to CPLR TUNE or KW TUNE position. When this is done, relay K1 pulls in and 28 VDC is switched on the CPLR TUNE + line (Pin J P1/J1). When the TUNE START push button is depressed on the Antenna Tuner Control Panel in the GSB-900, +28 VDC is switched onto the CPLR TUNE +R line (Pin K P1/J1). This action saturates 2A1Q15 and the following actions occur on 2A1:

1. The TUNE BSMV is set
2. The 50 ohm BSMV is reset
3. 2A1R17-C32 time constant is discharged
4. 2A1R15-C31 time constant is discharged
5. C1 home and L4 home pulses are generated
6. The FAULT BSMV is set

When the TUNE BSMV is set, the transmitter is keyed on by 2A1Q10 and the TUNING light is illuminated.

The CPLR TUNE pulse causes the following actions on 2A2:

1. The C1 Home BSMV is set
2. The L4 Home BSMV is set

These actions cause 2A2Q7 (\emptyset) and 2A2Q14 (A) servo preamplifiers to be saturated and both driven elements begin to home. As soon as the transmitter applies RF power to the input to the tuner, outputs occur from the phase and amplitude detectors (2A4). These voltages drive the differential ampli-

fiers on 2A2 and the level changers develop outputs. As soon as the phase becomes positive, the home drive is removed from the servo preamplifiers and normal error voltage tuning takes over. When the driven elements are positioned so the reflected power falls below the threshold, the 50 ohm BSMV is set and relay K4 falls out. The first time this occurs, it is usually a short pulse because the elements are being driven at full gain by the servo loops and they will overshoot. However, the overshoot reverses the polarity of both error voltages and the elements are driven back to the proper position. On some tunes the 50 ohm BSMV may be set and reset several times before the reflected power remains below the threshold continuously.

This action is extremely important to the tuning of the tuner. Each time a 50 ohm point is found the following occurs:

1. The 50 ohm BSMV is set
2. Relay K4 falls out applying full power to the phase and amplitude detectors.
3. The 50 (+) line shorts out the outputs from the level changers on 2A2.
4. The 50 (-) line causes a brake pulse to be generated and shorts out the input to the home servo preamplifiers.

All four of the above actions are required to stop servo loop oscillation and reduce tuning time.

When the reflected power has settled below the threshold, 2A1Q5 will generate a logic 1 and terminate the tune cycle.

(

(

(

SECTION V MAINTENANCE AND REPAIR

5.1 PERIODIC MAINTENANCE

In order to assure continued trouble free operation from the GCU-935 Antenna Tuner, the following periodic maintenance should be performed every 12 months.

1. To remove the GCU-935 from the case remove the 16 screws in the front panel. Remove the GCU-935 from the case.
2. Inspect the rubber cover gasket for signs of deterioration and possible water leaks. Carefully clean the gasket using a solvent such as Trichloroethane.
3. Check all hardware and retorque if necessary.
4. Apply a small amount of molybdenum grease such as "MOLYKOTE"* type G to the roller bar and end bearings of roller inductor, L4. Rotate L4 through its adjustment range several times to evenly distribute the grease.

CAUTION

Molybdenum grease is a special electrically conducting lubricant. The use of regular petroleum-based grease will cause erratic operation and will void the equipment warranty.

5. Lubricate the threaded shaft of the vacuum variable capacitor with a light weight petroleum base grease of Molybdenum grease (Sunair P/N 0840950004).
6. Carefully check the antenna coupler for the presence of foreign matter and corrosion and thoroughly clean.

*MOLYKOTE is the trademark of the Dow-Corning Corp.

7. Check L MAX, L MIN, C MAX, and C MIN limit switch settings in accordance with section 5.2.4.
8. After the solvent (applied in step 2, above) has thoroughly dried, coat the rubber cover gasket with silicone grease. Remount the cover on the coupler taking care to apply even torque to all the screws. **BE SURE** that the unit is water tight.

5.2 TROUBLESHOOTING AND REPAIR

5.3 REQUIRED TEST EQUIPMENT

1. Transceiver or Exciter
2. Thruline Wattmeter, 100W - Bird Model 43
3. Dummy Load, 50 ohm, @150W - Bird Model 8135
4. VTVM - HP Model 410C
5. Adapter SO-239 to BNC
6. Adapter Type N to BNC
7. Adapter, tee, BNC, double female
8. BNC to Clip lead cable 3 ft. long (for phase and magnitude Balance).
9. Coax cable: 5 foot (approximately) RG-58/U coax terminated at both ends in male BNC connectors.
10. TS-100 Antenna Simulator, Sunair Part Number 8084001094.

5.4 FAULT ISOLATION

Should a failure occur in the GCU-935, prior to proceeding to the detailed test of section 5.5, refer in Table 5-1 to isolate the problem to a sub-assembly level. This action should result in less test and maintenance time to repair the unit.

(

(

(

| SYMPTOM | PROBABLE CAUSE | REMEDY |
|---|---|--|
| No amber light when CPLR TUNE pushbutton depressed. | <ol style="list-style-type: none"> 1. Broken wire 2. 2A1Q15 is faulty 3. 2A1CR17 open 4. Amber bulb burned out 5. Tune BSMV not functioning | Repair using normal troubleshooting techniques. |
| Red light comes on after 40 seconds and RFL PWR meter oscillates. | <ol style="list-style-type: none"> 1. Gain control in Antenna Tuning unit control panel set too high 2. Broken wire in gain control circuit 3. Diode 2A1CR22 open | <ol style="list-style-type: none"> 1. Readjust gain control 2. Repair using normal troubleshooting techniques. |
| Red light comes on after 40 seconds but reflected power is zero and coupler is tuned. | <ol style="list-style-type: none"> 1. Low tuning power from GSB-900 2. GCU-935 K4 faulty 3. 2AIRF detector not functioning 4. Bad Fault BSMV | Repair using normal troubleshooting techniques. |
| Low tuning power from GSB-900. | <ol style="list-style-type: none"> 1. GCU-935 K4 faulty 2. Pad resistors faulty 3. Problem in GSB-900 | <ol style="list-style-type: none"> 1. Replace K4 or faulty resistors 2. Refer to GSB-900 manual. |
| Excess reflected power when tuning above 20 MHz. | <ol style="list-style-type: none"> 1. C2 (15-60 PF) in GCU-935 should be adjusted | <ol style="list-style-type: none"> 1. Adjust C2. |
| Excess reflected power on all frequencies. | <ol style="list-style-type: none"> 1. Gain control on Control panel adjusted too low 2. Phase Detector and magnitude detector should be readjusted | <ol style="list-style-type: none"> 1. Adjust gain control 2. Readjust Phase and magnitude detectors. |
| Will not tune below 3 MHz. Time delay continues to run out. | <ol style="list-style-type: none"> 1. L max switch not working properly 2. K2 relay not operating properly 3. K3 relay not operating properly | Repair using normal troubleshooting techniques. |
| Antenna tuner tunes ok gets green light but red light comes on SB or CW. | <ol style="list-style-type: none"> 1. Antenna or lead in arcing 2. Antenna tuner arcing internally 3. Frequency of transmit signal shifting from AM to SB or CW 4. Gain control adjusted too high | <ol style="list-style-type: none"> 1. Check antenna for arcing 2. Check antenna tuner for arcing 3. Check GSB-900 frequency. 4. Readjust gain control. |

TABLE 5.1 FAULT ISOLATION

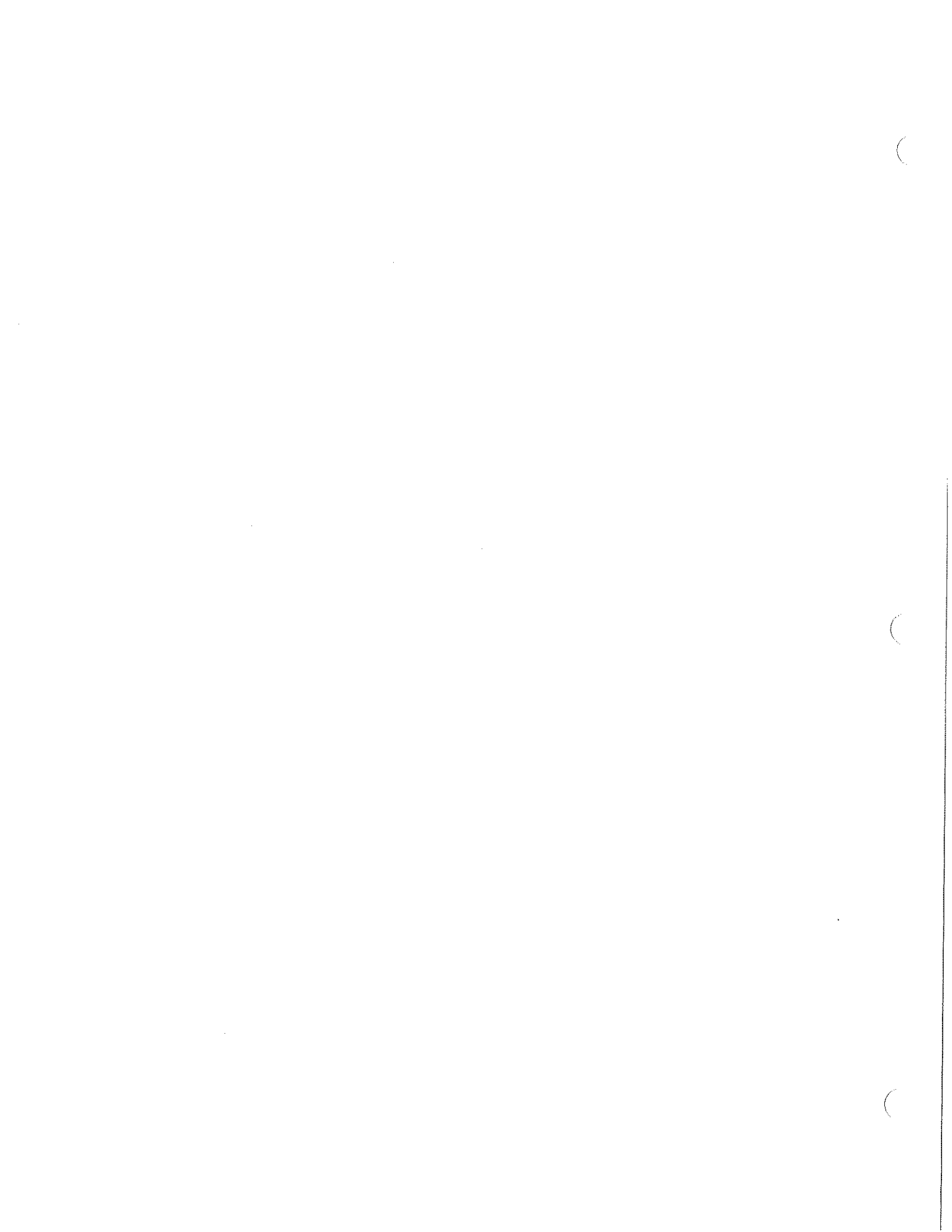

| SYMPTOM | PROBABLE CAUSE | REMEDY |
|---|--|---|
| Amber light comes on with CPLR TUNE pulse, but motors do not run. | <ol style="list-style-type: none"> 1. Relay K4 faulty 2. R3 or R9 open 3. 2A6 faulty 4. Bad motor 5. Reflected power detector faulty 6. 2A1U1 faulty | Repair using normal trouble-shooting techniques. |
| G5B-900 28V overload kicks out when mode switch placed in CPLR TUNE or KW TUNE. | <ol style="list-style-type: none"> 1. Short in GCU-935 on SW 28V line 2. Relay K1 faulty | <ol style="list-style-type: none"> 1. Remove short 2. Replace relay. |
| Antenna tunes properly but REF PWR meter does not read. | <ol style="list-style-type: none"> 1. GCU-935 2A1U1 or 2AIQ1 faulty 2. Broken cable wire 3. Faulty REF PWR detector in 2A4 | Repair using normal trouble-shooting techniques |
| Amber light comes on with CPLR TUNE pulse but GSB-900 not keyed on. | <ol style="list-style-type: none"> 1. 2AIQ10 faulty 2. Broken cable wire | <ol style="list-style-type: none"> 1. Replace transistor. 2. Check cable. |
| Antenna tuner tunes properly but cannot key GSB-900 with microphone. | GCU-935 relay K1 or broken wire in cable | Replace relay or check cable. |
| Roller on L4 runs to either end of coil and hits bracket. | <ol style="list-style-type: none"> 1. L max or L min switch not working properly 2. Broken wire 3. 2A2Q9 brake circuit not working 4. 2A2CR9 & CR10 open | Replace faulty components. |
| Capacitor C1 increases to maximum and shaft begins to Unscrew. | <ol style="list-style-type: none"> 1. C max micro switch not operating 2. Plunger not adjusted properly 3. 2A2U2 A & B not operating properly 4. Broken wire | Check C max switch for proper operation. Check for broken wire. |

TABLE 5.4 FAULT ISOLATION (CONT'D)

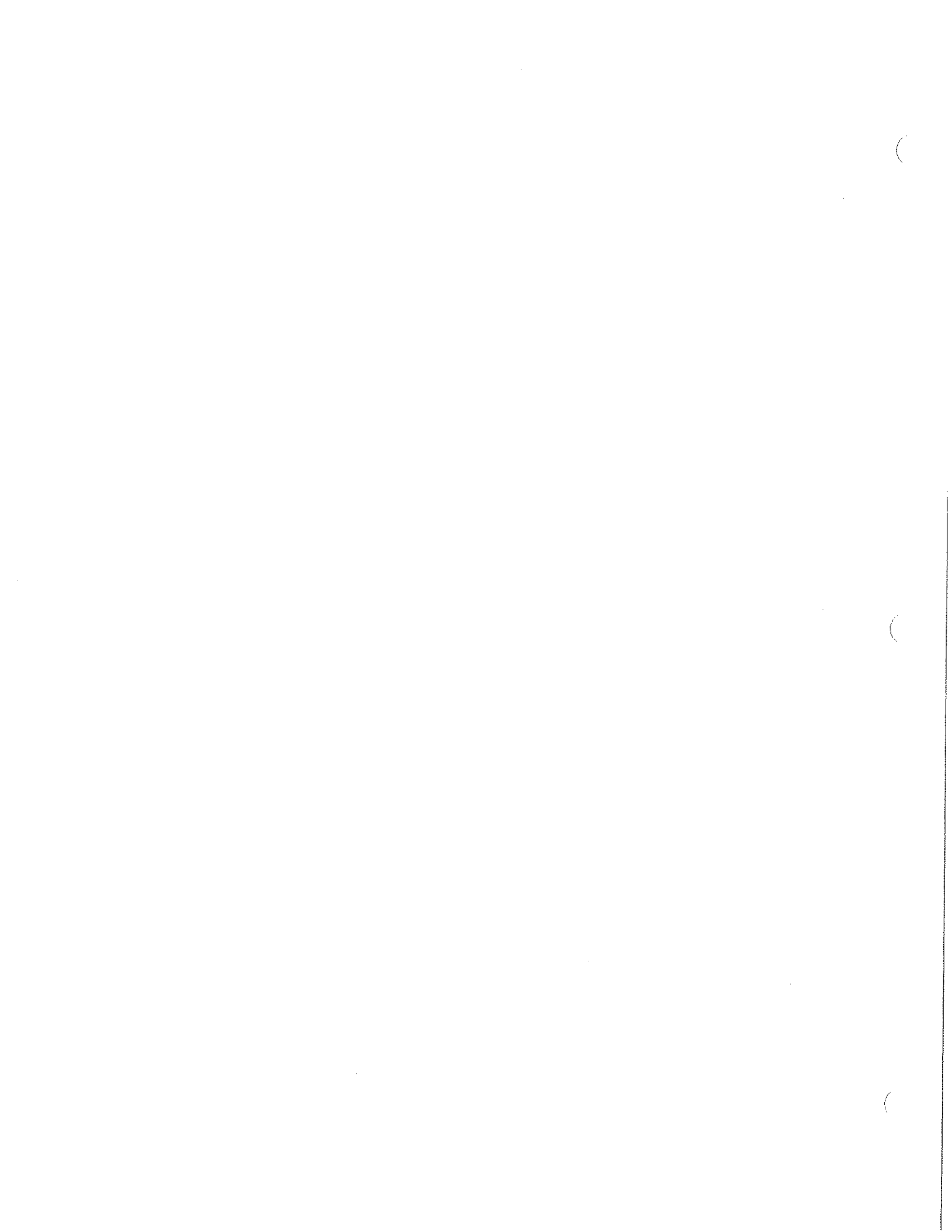

| SYMPTOM | PROBABLE CAUSE | REMEDY |
|---|--|--|
| <p>Capacitor C1 decreases to minimum and motor M1 stalls.</p> <p>When GSB-900 initially turned on RED light does not come on.</p> | <ol style="list-style-type: none"> 1. C min microswitch not operating 2. Plunger not set properly 3. 2A2CR5 open 4. Broken wire <ol style="list-style-type: none"> 1. Bulb bad 2. 2A1U4 A&B (fault BSMV) not coming on in proper state | <p>Check C min switch for proper operation. Check for broken wire.</p> <p>Repair using normal trouble-shooting techniques.</p> |

TABLE 5.1 FAULT ISOLATION (CONT'D)

(

(

(

5.5 TEST AND REPAIR

For test and repair of the GCU-935, the following troubleshooting procedure is recommended. Remove the GCU-935 from its case and remove the 2A1 and 2A2 P.C. boards. Connect the interconnecting cable between the GSB-900 and the GCU-935. Terminate the GSB-900 RF output with a 50 ohm resistive load. Turn the GSB-900 mode switch to the AM position.

5.6 2XA1 VOLTAGE TEST

Using the VTVM, check the DC voltages on the 2XA1 connector and see if they correspond to those listed in Table I.

CAUTION

2XA1 and 2XA2 connectors are dual readout types and care should be exercised to prevent shorting one side to the other (1 to A, 2 to B, etc.).

5.7 2XA1 GROUNDING TEST

Certain functions can be simulated by placing grounds on the pins of 2XA1. Use a short clip lead to the chassis and a thin bus wire for touching the pin on the connector.

- A. Ground pin V- Relay K2 should energize and remain energized after removing the ground from pin V. The next ground applied to pin V should cause K2 to fall out. (K2 is driven by a bi-stable relay 2A5K1.) 28V should appear on 2XA1 pin U when K2 is energized.
- B. Ground pin 17- relay K3 should energize when a ground is placed on pin 17 and remain energized when the ground is removed. The next ground applied to pin 17 should cause K3 to fall out (K3 is driven by 2A5K2, a bi-stable relay).
- C. Ground pin N- the green light in the GSB-900 control panel should illuminate. (Its brilliance can be adjusted by the dimmer control of the GSB-900.)

- D. Ground pin 6- The amber tuning light should be illuminated.
- E. Ground pin 12- The red fault light should be illuminated.
- F. Ground pin 7- This is the interlock line and should key the GSB-900 into transmit.
- G. Ground pin 15- Relay K4, the attenuator relay, should remain pulled in as long as the ground remains on pin 15.

5.8 2XA1 TROUBLESHOOTING

If any of the voltage measurements or grounding test on 2XA1 fail to produce the desired result normal troubleshooting techniques should be used. Check for broken wires on the connector or disconnect the control cable from the GCU-935 and use an OHM meter to check continuity between various points.

5.9 2XA2 VOLTAGE TEST

Using the V.T.V.M check the DC voltages on 2XA2 connector and see if they correspond to the voltage listed in Table II.

CAUTION

Do not short opposite pins together because the connector is a dual readout.

5.10 2XA2 GROUNDING TEST

By placing grounds on the pins of 2XA2, functions can be simulated to aid in checking the antenna tuner. Use a short clip lead to the chassis and a thin bus wire for touching the pins of the connector.

IMPORTANT NOTE

Grounding 2XA2 pins 4, 5, V and 17 will cause the motors to run if 2A6 is installed. Check the position of the roller on L4 and the vacuum variable capacitor position sensor bar before placing a ground on any of these pins.

(

(

(

2XA1 Connector Voltages
 All voltages $\pm 10\%$ (Referenced to chassis ground)

| PIN | FUNCTION | VOLTAGE | PIN | FUNCTION | VOLTAGE |
|-----|-------------|---------|-----|-----------|---------|
| A | CPLR TUNE | Note 1 | 1 | Ground | 0 |
| B | RF DETECTOR | 0 | 2 | SW 10V | Note 4 |
| C | | | 3 | REF PWR | 10V |
| D | | | 4 | 10V REF | 10V |
| E | | | 5 | | |
| F | 10V REF | 10V | 6 | Tuning | 12V |
| H | 28V | 28V | 7 | Interlock | 12V |
| J | 28V Nom | Note 2 | 8 | Gain | Note 5 |
| K | 10V REF | 10V | 9 | REF P | 0V |
| L | | | 10 | | |
| M | | | 11 | 50 (-) | 0 |
| N | Ready | 12V | 12 | Fault | 12 |
| P | 5V | 5V | 13 | C1 Home | 0 |
| R | Home L4 | 0 | 14 | 50 (+) | 0 |
| S | | | 15 | Pad Relay | 28V |
| T | L max | 0 | 16 | L min | 0 |
| U | C6 + | Note 3 | 17 | C3 cont | 28V |
| V | C6 cont. | 28V | 18 | Ground | 0 |

TABLE 5.2 2XA1 CONNECTOR VOLTAGES (WITH 2A1 & 2A2 REMOVED)

2XA1 Connector Voltage Notes

1. CPLR TUNE when GSB-900 mode switch in CPLR TUNE or KW TUNE and tune pushbutton is depressed, 2XA1 pin A should read 28V.
2. 28V NOM when the GSB-900 mode switch is in the USB, LSB, AM or CW position 2XA1 pin J should read 28V and should drop to 0V when mode switch is in the CPLR TUNE or KW TUNE position. (Relay K1 pulls in when GSB-900 mode switch is in CPLR TUNE or KW TUNE.)
3. C6 + 2XA1 pin U can be either 28V or 0 V depending on the state of K2. If K2 is energized, 2XA1 pin U should be 28V.
4. SW 10V when the GSB-900 mode switch is in the CPLR TUNE or KW TUNE position, 2XA2 pin 2 should be 10V.
5. Gain the gain control is located on the rear of the Antenna tuner control panel located in the GSB-900. Remove the top cover of the GSB-900 and adjust the potentiometer on the control panel and observe the voltage on 2XA1 pin 8. It should change from 12 to 22V. ($\pm 10\%$). Reset the gain control to approximate mid range.

(

(

(

2XA2 Connector Voltages
All Voltages \pm 10% (Referenced to chassis ground)

| PIN | FUNCTION | VOLTAGE | PIN | FUNCTION | VOLTAGE |
|-----|----------------------|---------|-----|-----------------------|---------|
| A | 28V | 28V | 1 | Ground | 0 |
| B | | | 2 | Phase Error | 10V |
| C | | | 3 | Phase Error (10V REF) | 10V |
| D | | | 4 | Phase Drive | 28V |
| E | | | 5 | Phase Drive | 28V |
| F | | | 6 | Home C1 | 0V |
| H | | | 7 | L max | Note 1 |
| J | | | 8 | C min | Note 4 |
| K | | | 9 | 50 (+) | 0V |
| L | | | 10 | 50 (-) | 0V |
| M | | | 11 | C max | Note 3 |
| N | | | 12 | Phase Brake | 0V |
| P | | | 13 | 5V | 5V |
| R | | | 14 | Home L4 | 0V |
| S | 10V | 10V | 15 | L min | Note 2 |
| T | Amp. Brake | 0V | 16 | Amp. Error | 10V |
| U | Amp. Error (10V REF) | 10V | 17 | Amp. Drive | 28V |
| V | Amp. Drive | 28V | 18 | Ground | 0 |

TABLE 5.3 2XA2 CONNECTOR VOLTAGES (WITH 2A1 & 2A2 REMOVED)

2XA2 Connector Voltage Notes

1. L max should have 0V. When a clip lead ground is placed on the plunger near the pulley end of the variable coil, pin 7 of 2XA2 should read 0 to 1 ohm resistance to chassis ground.
2. L min should have 0V. When a clip lead ground is placed on the plunger near the front of the variable coil, pin 15, 2XA2 should read 0 to 1 ohm resistance to chassis ground.
3. C max should have 0V. Connect an ohm meter between pin 11 2XA2 and chassis ground. Depress the front microswitch on C1 and the resistance should read from 0 to 1 ohm.
4. C min should have 0V. Connect an ohm meter between pin 8 2XA2 and chassis ground. Depress the rear microswitch (the one near the pulley) on C1 assembly and the resistance should read 0 to 1 ohm.

(

(

(

- A. Ground pin 4- the drive motor (M1) for the vacuum variable capacitor should run clockwise when viewed from the shaft end and the capacitor should decrease capacitance. (It should back the plunger out of the capacitor.) Do not sustain the ground until the position sensor hits the rear micro switch.
- B. Ground pin 5- motor M1 should reverse direction.
- Ground pin V- the drive motor (M2) for the variable inductor (L4) should run clockwise (when viewed from the shaft end) and the roller should run to the front of the inductor (approaching minimum L). Remove the ground before the roller strikes the front plunger (Lmin).
- D. Ground pin 17- Motor M2 should reverse direction.

5.11 2XA2 TROUBLESHOOTING

If any of the voltage measurements or grounding test on 2XA2 fail to produce the desired results normal troubleshooting techniques should be used. Check for broken wires on the connector or on chassis. An ohmmeter can be used to check continuity between pins of 2XA2 and pins of 2XA6.

5.12 2A6 SERVO MOTOR CONTROL ASSEMBLY

If the grounding test on pins 4, 5, 17 and V of 2XA2 does not cause motor rotation, and no broken wires are found, then the trouble could be in 2A6. Disconnect 2XA6 (cable) from 2A6 and check continuity between 2XA2 and 2XA6. If 4, 5, 17, and V are connected to D, R, H and C respectively, then the fault must be in 2A6 or the motors. The motors can be checked by applying 28V DC between 2XA6 pins N & P or E & B.

All of the transistors in the 2A6 module may be removed by removing the two nuts on each and pulling the transistor out. If the fault is in the 2A6 module, remove the TO-26 transistors. If all the TO-26 transistors check satisfactory then remove the TO-3 transistors (one at a time) and check the transistor with an ohmmeter for shorts or opens. If all the transistors check satisfactory, then the entire 2A6 module may be removed by removing the

two screws from the side and the one screw accessible from the top of the GCU-935.

When the 2A6 module is removed from the GCU-935, check the printed circuit board for burned resistors and shorted or open diodes.

5.13 2A1 AND 2A2 TEST

If all the tests on 2XA1, 2XA2, 2XA6, and 2A6 are satisfactory then the problem must be on 2A1 or 2A2. Turn off the GSB-900. Install 2A1 and 2A2 and disconnect 2XA6 from 2A6. Turn on the GSB-900, place the mode switch in CPLR TUNE position, and check the voltages on 2A1 and 2A2 and compare them with the voltages shown in Table III or Table IV.

5.14 2A1 FUNCTIONAL TEST

(GSB-900 mode switch in CPLR TUNE position with 2XA6 removed from 2A6.) If all the DC Voltages on 2A1 are within specification, the certain test can be performed to determine if functional blocks of circuitry are operating properly.

- A. Fault BSMV- Place a momentary clip ground on 2A1U4 pin 3. The red fault lamp should go off. Touch the ground to 2A1U4 pin 6 and it should come back on.
- B. Tune BSMV- Connect a clip lead to +28V (2XA1 pin H or the 28V end of R5). Momentarily touch the 28V clip lead to 2XA1 pin A (anode of CR17). The RED fault light should go off and the amber tuning light should come on. Also, the GSB-900 transmitter should be keyed on. After 40 seconds, the red light should come back on, the amber light should go off and the transmitter should unkey. (This action checks the Tune BSMV and the timer delay-Q16, Q17, and Q18.) Also, when the time-delay runs out, relay K3 should change state.
- C. Tune BSMV and Operate light-Initiate a tune cycle by applying a 28V pulse to the anode of CR17 as in step (B). Connect the 28V clip lead through a 10K $\frac{1}{4}$ w resistor to the RF detector, pin B (one end of R23). Within $\frac{1}{2}$ second the amber light should go off, the green operate light should come on and the GSB-900 transmitter should unkey.

(

(

(

All voltages measured after GSB-900 turned on and RED fault light is on. No CPLR TUNE pulse applied. GSB-900 mode switch in AM MODE. (MV = millivolts) All voltages referenced to chassis ground.

| TRANSISTOR OR I.C. | TEST POINT | DC VOLT ±10% | TRANSISTOR OR I.C. | TEST POINT | DC VOLT ±10% | |
|-----------------------|---------------|-----------------|-----------------------|---------------|-----------------|--------|
| U1 | 1 | 0 | U4 | 6 | 88 MV | |
| | 2 | 0 | | 7 | 9 MV | |
| | 3 | 20.5 | | 8 | 3.7 | |
| | 4 | 9.5 | | 9 | 4.7 | |
| | 5 | 9.5 | | 10 | 120 MV | |
| | 6 | 13.5 MV | | 11 | 72 MV | |
| | 7 | 0 | | 12 | 1.6 | |
| | 8 | 0 | | 13 | 3.7 | |
| | 9 | .75 | | 14 | 5 | |
| | 10 | 9.5 | | U5 | 1 | 68 MV |
| | 11 | 24.5 | | | 2 | 3.4 |
| | 12 | 21 | | | 3 | 3.6 |
| | 13 | 0 | | | 4 | 5.5 V |
| | 14 | 0 | | | 5 | 100 MV |
| U2 | 1 | .6 | 6 | | 4 | |
| | 2 | 1.6 | 7 | 9 MV | | |
| | 3 | 100 MV | 8 | 110 MV | | |
| | 4 | 100 MV | 9 | 1.6 | | |
| | 5 | 110 MV | 10 | 1.6 | | |
| | 6 | 3.7 | 11 | 3.8 | | |
| | 7 | 4.2 MV | 12 | .44 | | |
| | 8 | 90 MV | 13 | .22 | | |
| | 9 | 4.4 | 14 | 5 | | |
| | 10 | 1.55 | U6 | 1 | 75 MV | |
| | 11 | 95 MV | | 2 | 200 MV | |
| | 12 | 3.8 | | 3 | 3.4 | |
| | 13 | 4.6 | | 4 | 3.4 | |
| | 14 | 4.9 | | 5 | 125 MV | |
| U3 | 1 | 4.8 | | 6 | 4.3 | |
| | 2 | 1.65 | 7 | 4.5 MV | | |
| | 3 | 115 MV | 8 | 3.8 MV | | |
| | 4 | 1.55 | 9 | 4.3 | | |
| | 5 | 3.4 | 10 | .35 | | |
| | 6 | 100 MV | 11 | 75 MV | | |
| | 7 | 10 MV | 12 | 3.5 | | |
| | 8 | 3.4 | 13 | 5 | | |
| | 9 | .37 | 14 | 5 | | |
| | 10 | 3.7 | Q1 | E | 9.5 | |
| | 11 | 3.7 | | B | 10.5 | |
| | 12 | 3.4 | | C | 18 MV | |
| | U4 | 13 | 88 MV | Q2 | E | 20 MV |
| | | 14 | 4.9 | | B | 20 MV |
| U4 | | 1 | 3.7 | | C | 14.5 |
| | | 2 | .38 | Q3 | E | 20 MV |
| | | 3 | 3.3 | | B | .8 |
| 4 | 3.3 | C | 70 MV | | | |
| | 5 | 3.4 | Q4 | E | 20 MV | |

TABLE III - 2A1 DC VOLTAGES

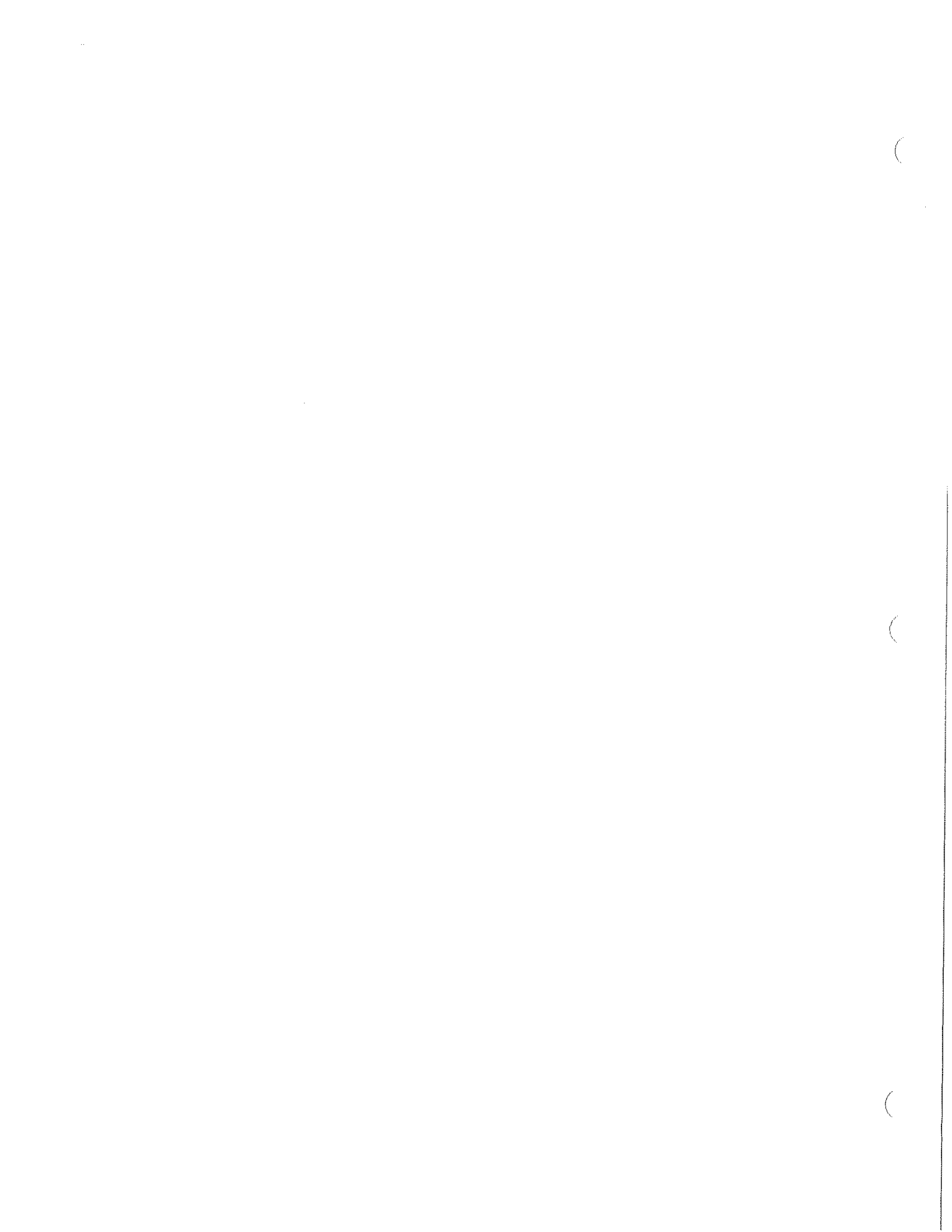

SUNAIR GCU-935

All voltages measured after GSB-900 turned on and RED fault light is on. No CPLR TUNE pulse applied. GSB-900 mode switch in AM MODE. (MV = millivolts) All voltages referenced to chassis ground.

| TRANSISTOR OR I.C. | TEST POINT | DC VOLT ±10% |
|-----------------------|---------------|-----------------|
| Q4 | B | 79 MV |
| | C | 17 |
| Q5 | E | 4.7 |
| | B | 5.4 |
| Q6 | C | 5 |
| | E | 0 |
| Q7 | B | 90 MV |
| | C | 28 |
| Q8 | E | 0 |
| | B | 82 MV |
| Q9 | C | 28 |
| | E | 13 MV |
| Q10 | B | 0 |
| | C | 5 |
| Q11 | E | 13 MV |
| | B | 100 MV |
| Q12 | C | 28 V |
| | E | 13 MV |
| Q13 | B | 105 MV |
| | C | 11.5 |
| Q14 | E | 13 MV |
| | B | 72 MV |
| Q15 | C | 28 |
| | E | 14 MV |
| Q16 | B | .74 |
| | C | 100 MV |
| Q17 | E | 4 MV |
| | B | 65 MV |
| Q18 | C | 5 V |
| | E | 4 MV |
| Q19 | B | 90 MV |
| | C | 28 |
| Q20 | E | 12 MV |
| | B | 12 MV |
| Q21 | C | 5 |
| | E | 7 MV |
| Q22 | B | .65 |
| | C | 55 MV |
| Q23 | A | 40 MV |
| | G | 3.5 |
| Q24 | K | 9 MV |
| | E | 6 MV |
| Q25 | B | 10 MV |
| | C | 5 |

TABLE 5.4 2A1 DC VOLTAGES (CONTINUED)

(

(

(

All voltages measured after GSB-900 turned on and RED fault light is on. No CPLR TUNE pulse applied
GSB-900 mode switch in AM MODE. (MV = millivolts) All voltages referenced to chassis ground.

| TRANSISTOR OR I.C. | TEST POINT | DC VOLT ±10% | TRANSISTOR OR I.C. | TEST POINT | DC VOLT ±10% | |
|-----------------------|---------------|-----------------|-----------------------|---------------|-----------------|--------|
| U1 | 1 | 0 | U4 | 5 | .52 | |
| | 2 | 0 | | 6 | 3.57 | |
| | 3 | 22 | | 7 | 4.5 MV | |
| | 4 | 9.5 | | 8 | 62 MV | |
| | 5 | 9.5 | | 9 | 5 | |
| | 6 | 3.5 MV | | 10 | 3.57 | |
| | 7 | 0 | | 11 | 3.57 | |
| | 8 | 0 | | 12 | .35 | |
| | 9 | .78 | | 13 | .5 | |
| | 10 | 9.5 | | 14 | 5 | |
| | 11 | 25 | | U5 | 1 | 3.57 |
| | 12 | 22 | | | 2 | 3.57 |
| | 13 | 0 | | | 3 | 100 MV |
| | 14 | 0 | | | 4 | 100 MV |
| U2 | 1 | 5 | 5 | | 100 MV | |
| | 2 | 2.4 | 6 | | 5 | |
| | 3 | 100 MV | 7 | | 4.5 MV | |
| | 4 | .3 | 8 | | 92 MV | |
| | 5 | 5 | 9 | | 1.65 | |
| | 6 | 3.2 | 10 | | 1.65 | |
| | 7 | 4.5 MV | 11 | | 90 MV | |
| | 8 | 100 MV | 12 | | 1.6 | |
| | 9 | 3.2 | 13 | | 1.6 | |
| | 10 | 1.5 | 14 | | 5 | |
| | 11 | 95 MV | Q1 | E | 3 | |
| | 12 | 1.6 | | B | 9.5 | |
| | 13 | 1.6 | | C | 28 | |
| | 14 | 5.0 | Q2 | E | 10 | |
| U3 | 1 | 0 | | B | 10 | |
| | 2 | 0 | | C | 12 | |
| | 3 | 21.0 | Q3 | E | 28 | |
| | 4 | 9.5 | | B | 28 | |
| | 5 | 9.5 | | C | 6.5 MV | |
| | 6 | 2.5 | Q4 | E | 5 MV | |
| | 7 | 0 | | B | 5 MV | |
| | 8 | 0 | | C | 5 | |
| | 9 | .72 | Q5 | E | 5 MV | |
| | 10 | 10 | | B | .7 | |
| | 11 | 25.6 | | C | 80 MV | |
| | 12 | 22.5 | Q6 | E | 4 MV | |
| | 13 | 0 | | B | 25 MV | |
| | 14 | 0 | | C | 12 MV | |
| U4 | 1 | 5 | Q7 | E | 4 MV | |
| | 2 | 3.57 | | B | 80 MV | |
| | 3 | 65 MV | | C | 13 MV | |
| | 4 | .35 | Q8 | E | 3.5 MV | |

TABLE 5.5 - 2A2 DC VOLTAGES

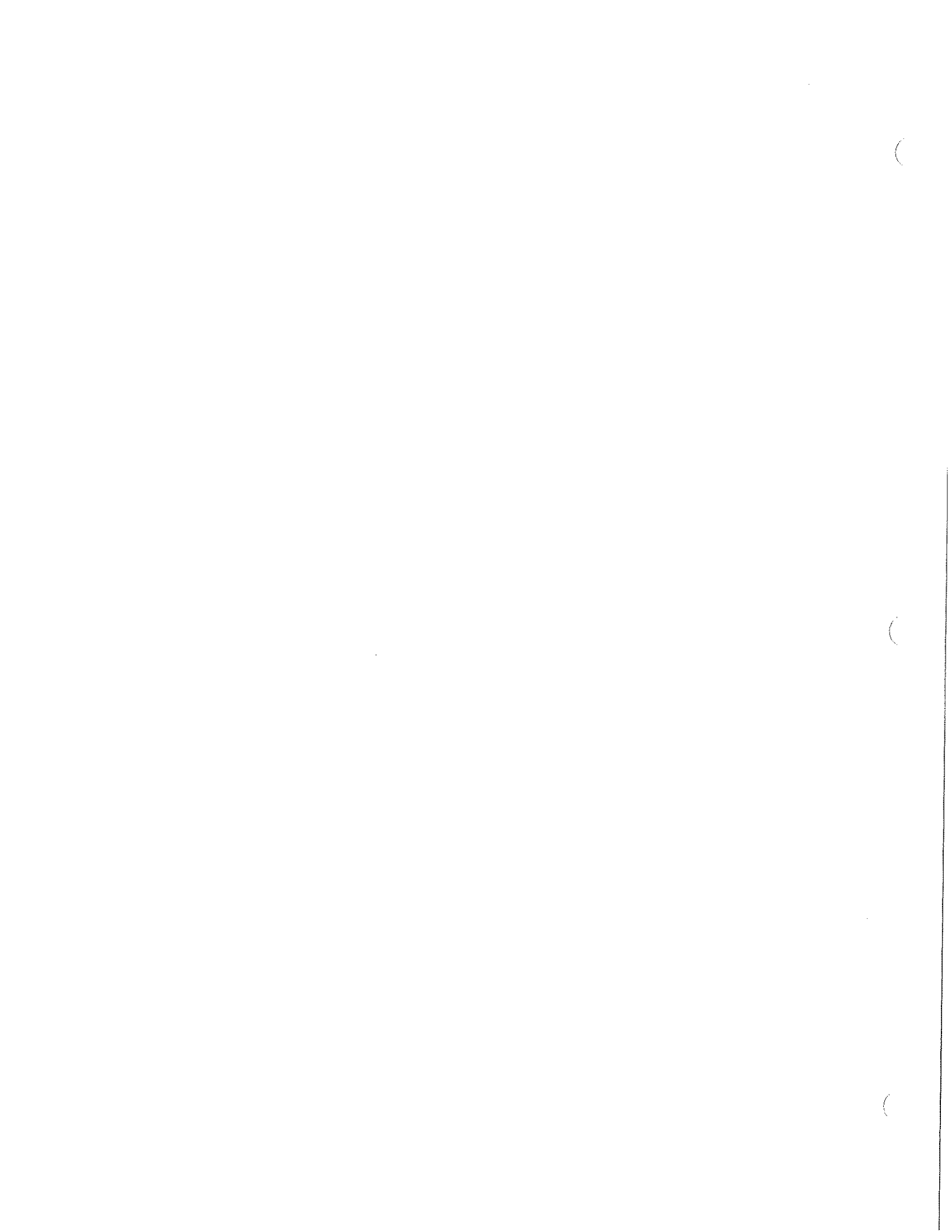

SUNAIR GCU-935

All voltages measured after GSB-900 turned on and RED fault light is on. No CPLR TUNE pulse applied. GSB-900 mode switch in AM MODE. (MV = millivolts) All voltages referenced to chassis ground.

| TRANSISTOR OR I.C. | TEST POINT | DC VOLT ±10% |
|-----------------------|---------------|-----------------|
| Q8 | B | .68 |
| | C | 1.3 |
| Q9 | E | 3.5 MV |
| | B | .7 |
| Q10 | C | 1.3 |
| | E | 9.5 |
| | B | 9.5 |
| Q11 | C | 28 |
| | E | 9.5 |
| | B | 9.5 |
| Q12 | C | 8.5 MV |
| | E | 28 |
| | B | 28 |
| Q13 | C | 6 MV |
| | E | 4.2 MV |
| | B | 52 MV |
| Q14 | C | 12 MV |
| | E | 4 MV |
| | B | 55 MV |
| | C | 12 MV |

TABLE 5.5 - 2A2 DC VOLTAGES (CONTINUED)

(

(

(

- D. Change the GSB-900 mode switch to the AM position. With the green operate light on, apply a 28V pulse through a 10K resistor to pin B (one end of R23). Using another clip lead and a 10K resistor, apply a positive input to pin 3. With the application of this pulse to pin 3, the red light should come on and relay K4 should pull in. Remove the input to pin 3 and relay K4 should fall out but the red fault light should remain on.
- E. Remove the 28V clip leads. With the GSB-900 mode switch in the AM position, place a ground on the L max plunger (on rear of inductor). Relay K2 should pull in if it were not energized and should fall out if it were pulled in. Ground L min plunger and K2 should fall out. Continue to ground L min and K2 should remain de-energized.
- F. If steps (A) through (E) do not result in isolating the fault and successful repair of 2A1, replace the PC board with a spare and return the faulty board for repair.
- D. Positive phase termination Circuitry- Momentarily ground U2 pin 6, U4 pin 6, and U4 pin 11. Connect a clip lead ground through a 10K ¼w resistor to 2XA2 pin 3. Remove this ground and check the state of the three BSMVS. U2 pin 3, U4 pin 3, and U4 pin 8 should all be logic 0 again.
- E. Phase preamplifier- Monitor the collector of Q3 with a VTVM. Place a clip lead ground through a 10K ¼w resistor on 2A2U1 pin 4. Q3 collector should rise to 21 volts, (±10%). Remove the clip lead ground and Q3 collector should drop to zero volts. Move the ground to U1 pin 5. Monitor the collector of Q2 and it should rise to 7.6 volts (±10%). Remove the ground and Q2 collector should fall to near zero volts.
- F. Amplitude preamplifier- Monitor the collector of Q12 with a VTVM and place a clip lead ground (through a 10K ¼ watt resistor) on 2A2U3 pin 5. Q12 collector should rise to 21 volts (±10%). Remove the ground and Q12 collector should fall to zero volts. Move the ground to 2A2U3 pin 5 and monitor the collector of Q11. Q11 collector should rise to 7.6 volts (±10%) and should fall to zero when the clip lead ground is removed.

5.15 2A2 FUNCTIONAL TEST (GSB-900 MODE SWITCH IN CPLR TUNE POSITION AND WITH 2XA6 REMOVED FROM 2A6)

IMPORTANT NOTE

Make sure L min, L max, C min and C max switches are not engaged.

- A. C1 Home BSMV- This BSMV is U2A and B. Place a momentary clip lead ground on U2 pin 6 and monitor U2 pin 3. The ground on U2 pin 6 should cause U2 pin 3 to rise to a logic 1. Place a momentary ground on U2 pin 3 and U2 pin 6 should rise to logic 1.
- B. L4 Home BSMV- U4 A & B is the L4 home BSMV. Momentarily ground U4 pin 6 and U4 pin 3 should rise to a logic 1. Momentarily ground U4 pin 3 and U4 pin 6 should rise to logic 1.
- C. L4 Force BSMV- U4 C & D is the L4 Force BSMV. Momentarily ground U4 pin 11 and U4 pin 8 should rise to logic 1. Momentarily ground U4 pin 11 and U4 pin 8 should return to logic 1.

- G. If steps (A) through (F) do not result in the isolation of the fault and successful repair of the 2A2 board, replace with a spare board and return the faulty board for repair.

5.16 ENTIRE GCU-935 FUNCTIONAL TEST

Turn off the GSB-900. Connect 2XA6 to 2A6. Turn on the GSB-900 and note red light comes on. No motor should run when the GSB-900 is initially turned on. Place the GSB-900 mode switch in the CPLR TUNE or KW Tune position. Terminate the GSB-900 RF output with 50 ohm load- do not put any RF into the antenna tuner.

5.17 2A2 AND 2A6 HOME AND FORCE FUNCTIONS

Place a clip lead ground on the collector of 2A1Q2. (This action removes the brake voltage from both phase and magnitude servo amplifiers.) Observe the variable inductor (L4) and ground the collector of

(

(

(

2A2Q13 until the inductor roller runs to approximately $\frac{1}{2}$ maximum inductance. Remove the ground from 2A2Q13 collector and the inductor should stop turning. Observe the variable capacitor and place a clip lead ground on the collector of 2A2Q6. The variable capacitor should move toward minimum capacitance. Remove the ground from the collector of 2A2Q6 when the capacitor reaches near minimum.

With the clip lead ground still on 2A1Q2 and L4 and C1 in midrange positions, momentarily ground the collector of 2A1Q15. L4 should begin running toward minimum L and C1 should run toward maximum C. When L4 reaches minimum L it should stop abruptly and remain at minimum until C1 reads maximum. L4 should then begin running toward maximum L. (This is the L min - C max force function 2A2U4 C & D.) L4 should reach max. L, switch in C6 (Relay K2), reverse direction and run until it again reaches minimum L. C6 should be switched out and the cycle should continue. Momentarily ground pin 5 of 2A2U2 and the inductor should stop turning. (A logic 0 on pin 5 on 2A2U2 simulates a positive phase angle.)

With the clip lead ground still on the collector of 2A1Q2, place a ground on the collector of 2A2Q6 and run the capacitor out toward minimum capacity. Stop motion of the capacitor before minimum by removing the ground from 2A2Q6. Momentarily ground the L max plunger and the capacitor should run to maximum capacitance and stop. Again run the capacitor to near minimum by grounding the collector of 2A2Q6. Stop the capacitor at near minimum capacitance and then manually depress the C min micro switch. The capacitor should run to maximum capacity and stop. Remove the clip lead ground from the collector of 2A1Q2.

Section 5.17 completes all the internal functional test on the GCU-935 for isolating faults and simulating operational functions. If the preceding test and simulations do not result in successful repair of the unit then the replacement of 2A1, 2A2, and 2A6 should result in successful repair.

5.18 GCU-935 INTERNAL ADJUSTMENTS L MAX, L MIN, C MAX AND C MIN LIMIT SWITCH SETTINGS SHOULD BE CHECKED ON A PERIODIC MAINTENANCE SCHEDULE

Phase detector and magnitude detector balance need to be adjusted only when tuning indicates improper setting of these adjustments.

5.19 INDUCTOR L4 MAXIMUM AND MINIMUM LIMIT SWITCH ADJUSTMENT

Turn off the GSB-900 and remove the cover from the GCU-935. Connect an ohmmeter between the L max plunger and chassis ground. Turn the inductor counter clockwise (viewed from the pulley end) until the roller on the coil strikes the L max plunger and the ohmmeter reads a short. Note the distance between the roller and the end of the wire of the coil. It should be between $\frac{1}{4}$ inch and $\frac{3}{4}$ inch. If the distance is greater than $\frac{3}{4}$ inch, adjust the elastic stop nut clockwise until the distance is proper. (Grasp the plunger with a pair of pliers.) This distance determines the maximum inductance available for tuning. If it is as much as $\frac{1}{2}$ turn, some impedances will not tune properly.

Remove the ohmmeter from the L max plunger and move to the L min plunger. Turn the inductor clockwise until the roller strikes the plunger and the ohmmeter reads a short. Note the distance from the roller to the end of the wire on the coil. It should be between $\frac{1}{4}$ inch and $\frac{1}{2}$ inch. If the distance is not correct, adjust the elastic stop nut on the plunger until it is correct. Use the same method as the adjustment for L max. Remove the ohmmeter.

Lubricate the L max and L min plungers and springs with molykote. This assures a good electrical contact between the plunger and the spring.

5.20 CAPACITOR C1 C MAX AND C MIN ADJUSTMENT

Connect an ohmmeter between 2XA2 pin 11 and chassis ground. Turn the capacitor shaft counter clockwise (viewed from the pulley end) until the

(

(

(

ohmmeter reads a short. Note the position of the pulley. Continue rotating the shaft counter clockwise until the shaft just begins to pull out of the capacitor end plate. The pulley should rotate between one and two full revolutions after the C max switch closes and before the shaft begins to pull out of the capacitor end plate. If this adjustment is not correct, adjust the elastic stop nut on the C max plunger in such a direction as to correct the problem. Another method of adjusting the C max switch is to tighten the elastic stop nut on the C max switch several revolutions, and adjust the capacitor shaft counter clockwise until the shaft just begins to pull out of the capacitor end plate. Turn the shaft 2 full revolutions clockwise. Adjust the C max plunger until the micro switch just closes (ohmmeter reads a short). Remove the ohmmeter from 2XA2 pin 11.

Move the ohmmeter to between 2XA2 pin 8 and chassis ground. Adjust the shaft of the variable capacitor clockwise 15 turns (from the position where C max just opens). At this point C min microswitch should close and the ohmmeter should read a short. In other words, the shaft should turn between 16 and 17 turns from absolute maximum capacity (the point where the shaft begins to unscrew) to the point where C min switch should close. Remove the ohmmeter.

5.21 PHASE AND MAGNITUDE DETECTOR ADJUSTMENT

Turn off the GSB-900 and disconnect the output of the phase and magnitude detectors from the post protruding from the chassis beneath the variable capacitor. The wire going to transformer T1 is removed. Connect the BNC to clip lead cable to the post from the phase and magnitude detectors and the ground post adjacent to it. **MAKE SURE THAT THE LEADS ON THE CABLE ARE NO LONGER THAN ½ inch.** This is important because any longer lengths of exposed center conductor and braid will cause error in the phase detector adjustment. Connect the BNC connector to the 50 ohm load.

5.22 AMPLITUDE DETECTOR ADJUSTMENT

Connect the VTVM between 10V Ref. and the amplitude detector output. The amplitude detector output is output 5 on 2A4 or pin 16 on 2XA2. The 10V ref is on the chassis mounted diode or output number 1 or 4 on 2A4. Turn on the GSB-900 and connect its RF output into the antenna tuner. Turn

the mode switch to AM and key the microphone. Note the wattmeter and forward power should be between 30 and 40 watts and the reflected power should be zero. Set the frequency to 1.6 MHz and observe the VTVM reading. It should read less than ± 1 volt. Check the VTVM reading for frequencies from 2 to 29.9 MHz in one MHz steps and note the meter readings. If the VTVM readings exceed $\pm 1V$ capacitor 2A4C1 should be readjusted. This is best accomplished by setting the GSB-900 frequency to 1.6 MHz and adjusting 2A4C1 until the VTVM reads less than .005V, preferably -.005V with respect to the 10V reference. Recheck the balance in MHz steps to 29.9 MHz. Typical readings would be -.050V at 1.6 MHz crossing to a positive voltage at 3 to 4 MHz, +.050V at 10 MHz and crossing again at 18 to 22 MHz. The 29.9 MHz reading would be typically -.050V. These voltages would all be referenced to the 10V referenced. Adjust the frequency of the GSB-900 to 2 MHz. Connect a clip lead to the ungrounded side of R6 (200 ohm 14 W pad resistor) located on the inside of the rear panel. Connect the other end of the clip lead to the RF output of the phase detector. Key the GSB-900 on the AM and the VTVM should read a positive voltage in excess of .1V. This action simulates a load of less than 50 ohms and the output from the amplitude detector should be positive. Remove the clip lead. Remove the 50 ohm load from the BNC connector and key the GSB-900 on in AM. The VTVM should read a negative voltage in excess of .1 volt.

5.23 PHASE DETECTOR ADJUSTMENT

Use the same test setup as in 5.22. Connect the 50 ohm load to the output of the Phase and Amplitude Detector (2A4). Connect the VTVM between 10V reference and Phase output. The phase output of 2A4 is output 2 or pin 2 of 2XA2. Connect the ground side of the VTVM to 10V reference. (Output 1 or 4 of 2A4 is 10V reference or also the chassis mounted zener may be used.) Set the frequency of the GSB-900 to 1.6 MHz and key on in AM. Note the VTVM should read less than .1 volt. Check frequencies from 2 to 29.9 MHz and note the readings. All readings should be less than ± 1 volt. If the phase detector needs to be rebalanced, set the frequency of the GSB-900 to 29.9 MHz and adjust 2A4R5 for a zero balance at 29.9 MHz. Recheck 1.6 MHz and note the VTVM reading. It should be less than $\pm 1V$. The Balance of the phase detector with 2A4R5 usually requires

(

(

(

splitting the difference between the error at 1.6 MHz and 29.9 MHz.

Try to adjust 2A4R5 so the error at 1.6 MHz is negative with respect to the 10V reference and less than .1V and the error at 29.9 MHz is positive with respect to the 10V reference and less than .1V. After adjusting 2A4R5, set the frequency of the GSB-900 to 2 MHz and key on in AM. Momentarily short an inductor (5 to 10 microhenries) across the RF output of the phase and amplitude detector. The VTVM should increase in a positive direction in excess of .1 volt. This indicates an inductive phase angle. Momentarily short a capacitor (.001Uf to .005Uf) across the RF output from 2A4. The VTVM should increase in a negative direction in excess of .1 volt.

5.24 REFLECTED POWER DETECTOR CHECK

There is no separate adjustment for the reflected power detector. It is a function of the setting of the amplitude detector voltage capacitor, 2A4C1. However, it should be balanced to less than .1 volt for all frequencies. The reflected power output is output number 3 on 2A4 or 2XA1 pin 3. The reflected power output always is positive and dips

when the detector is terminated by a 50 ohm load. Check the VTVM for output from 1.6 to 29.9 MHz in 1 MHz steps and make sure the error voltage is less than .1 volt. Momentarily remove the 50 ohm load with the GSB-900 keyed on in transmit and note the reflected power detector output on the VTVM. It should rise to more than .1 volts. Reconnect the 50 ohm load and momentarily ground the RF output from the phase and amplitude detector. The reflected power output should increase to greater than .1 volt.

5.25 2A4 REPAIR

Should a phase and amplitude detector fail to function as required, it may be removed from the chassis by removing the two screws in the side of the chassis, unsoldering the 5 dc output leads and removing the RF input wire. Prior to removal the top cover may be removed and a visual inspection made for broken wires or broken parts. The bottom cover may be removed and soldering inspected. Ohmmeter test can be made to determine if chokes and diodes are open or shorted. If the entire 2A4 assembly is replaced, the phase and amplitude adjustments must be made after the assembly is screwed into place with both top and bottom covers attached.

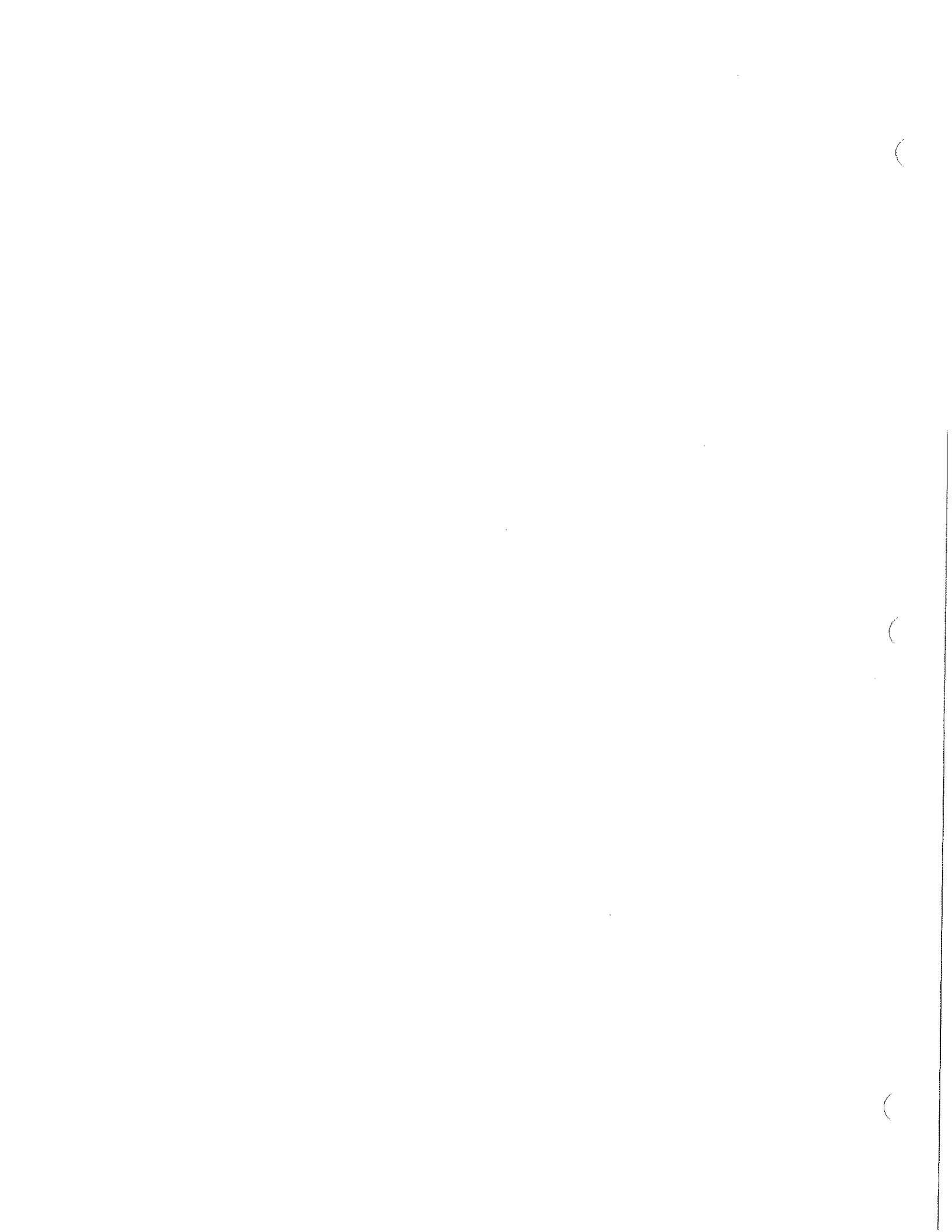

The following pages contain schematic diagrams,
and parts list for all assemblies of the GCU-935.

(

(

(

THIS PAGE INTENTIONALLY LEFT BLANK.

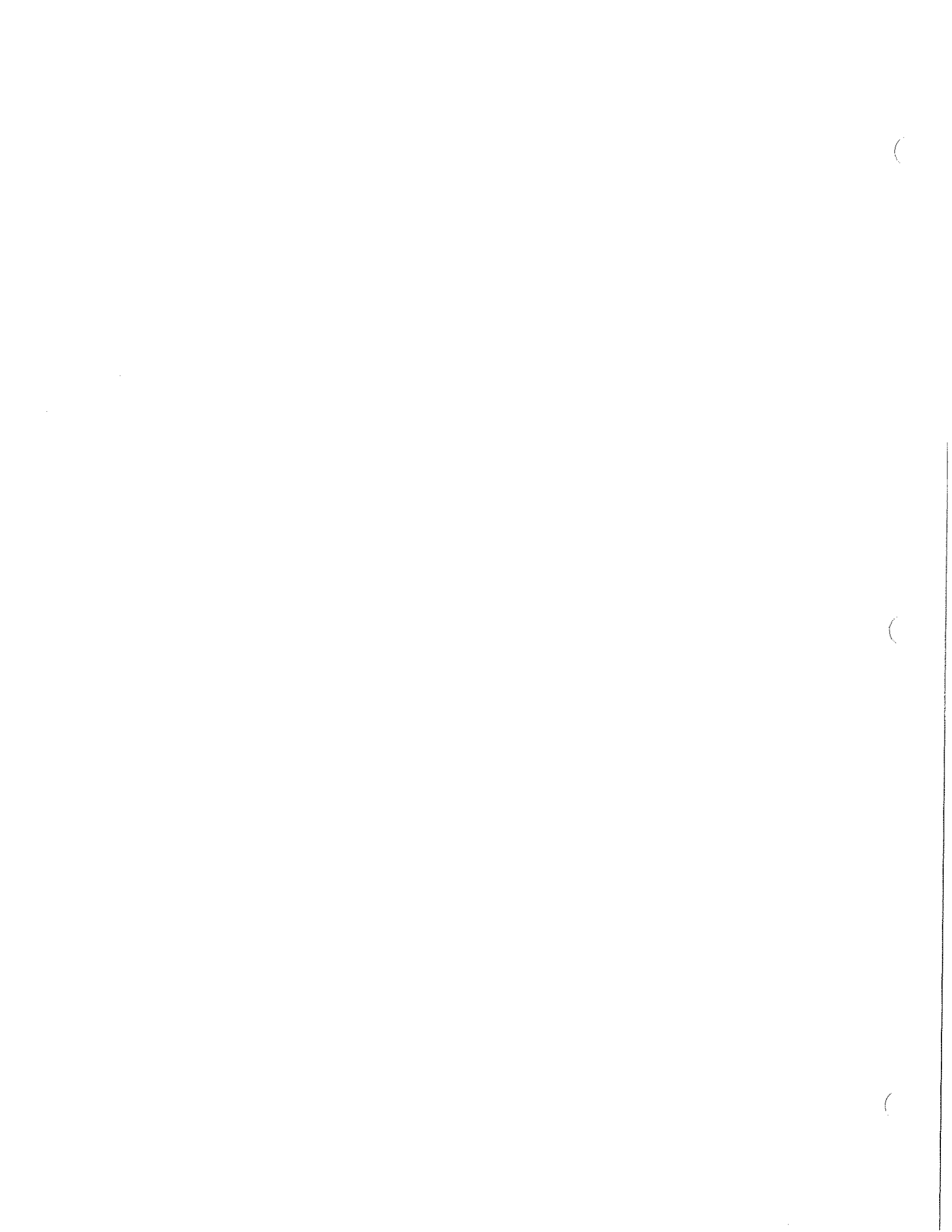

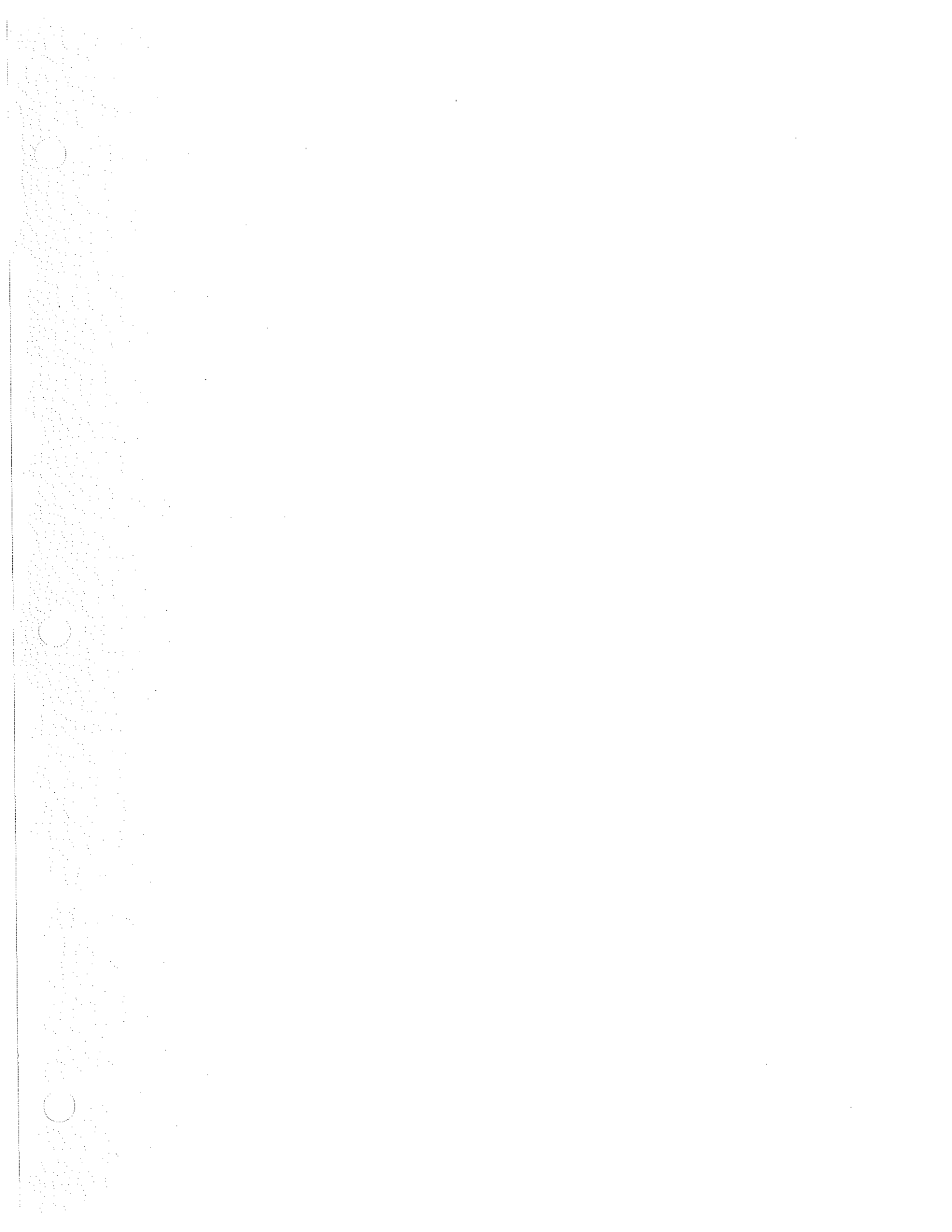

(

(

(

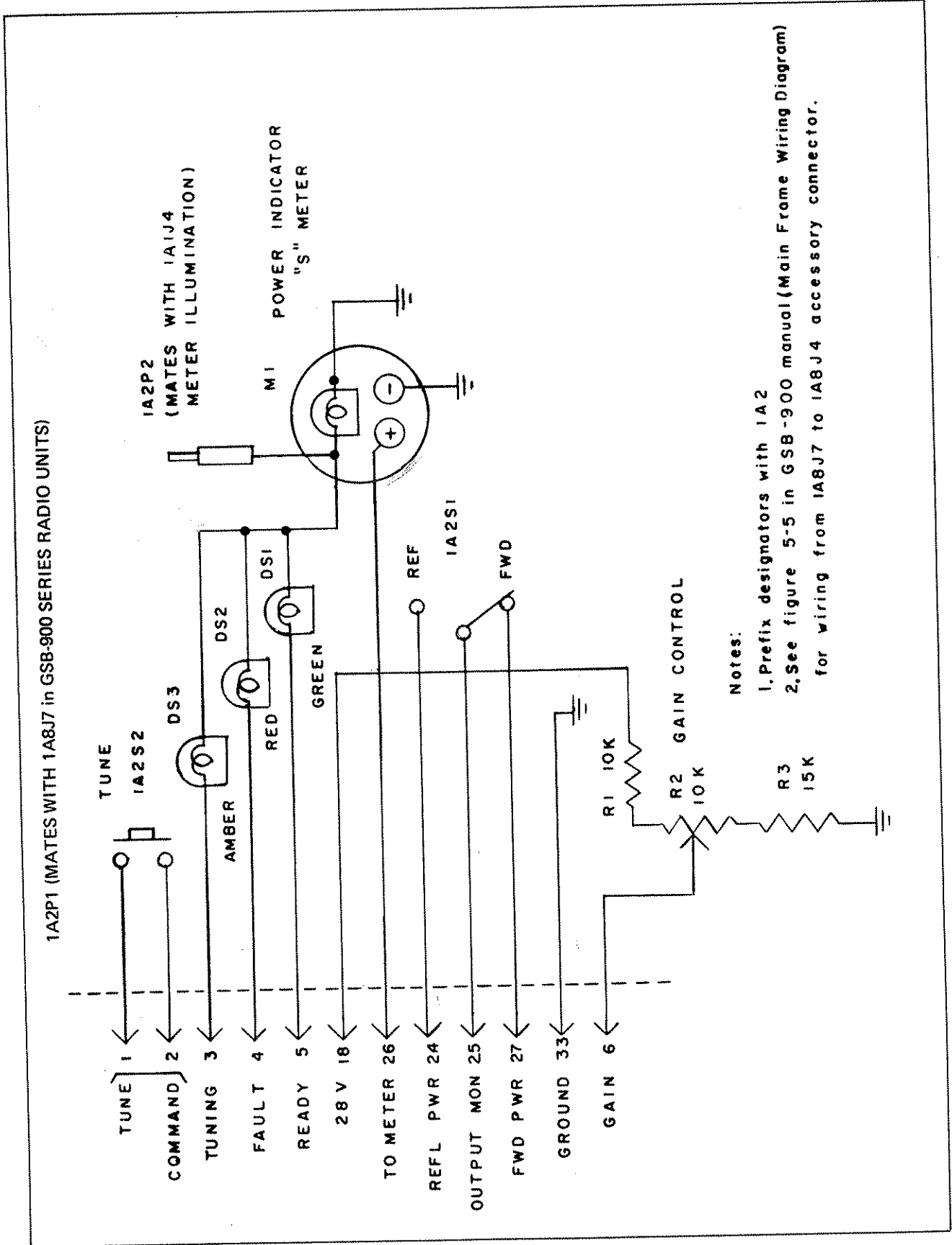

Figure 5.5 Schematic Diagram GCU-935 Antenna Tuning Control Unit

(

(

(

SUNAIR GCU-935

6035150055K CPLR. TUN. CONT.

| REF SYMBOL | DESCRIPTION | SUNAIR PART NO. |
|------------|----------------------------------|-----------------|
| | CPLR. TUN. CONT. GCU-935 | 6035150055 |
| 1A2P1 | Connector, Power, 36 Pin Rect. | 0754070000 |
| 1A2S1 | Switch, Toggle DPDT | 0334610001 |
| 1A2S2 | Switch, Pushbutton, SPST, N.O. | 0346520002 |
| DS1 | Lamp Assy. Green | 0841480001 |
| DS2 | Lamp Assy. Red | 0841490007 |
| DS3 | Lamp Assy. Amber | 0841500002 |
| M1 | Meter | 5024042204 |
| P2 | Plug, Phone Tip, Red | 0753680009 |
| R1 | Resistor, 10 K, 10%, 1/4 W | 0170410005 |
| R2 | Pot. 10 K, 10%, 3/4 W, 1/8 Shaft | 0335900003 |
| R3 | Resistor, 15 K, 10%, 1/4 W | 0173250000 |
| | Boot, Pushbutton Switch 1/2-40 | 0346530008 |

(

(

(

SECTION VI

ILLUSTRATED PARTS BREAKDOWN

6.1 This section has been designed to aid you in your maintenance and repair of your GCU-935. It will assist you in ordering parts and when disassembling or assembling your unit. Each major

assembly and chassis component has been called out and numbered. On the next page following each drawing you will find that each item is listed, described and its Sunair part number given.

(

(

(

THIS PAGE INTENTIONALLY LEFT BLANK.

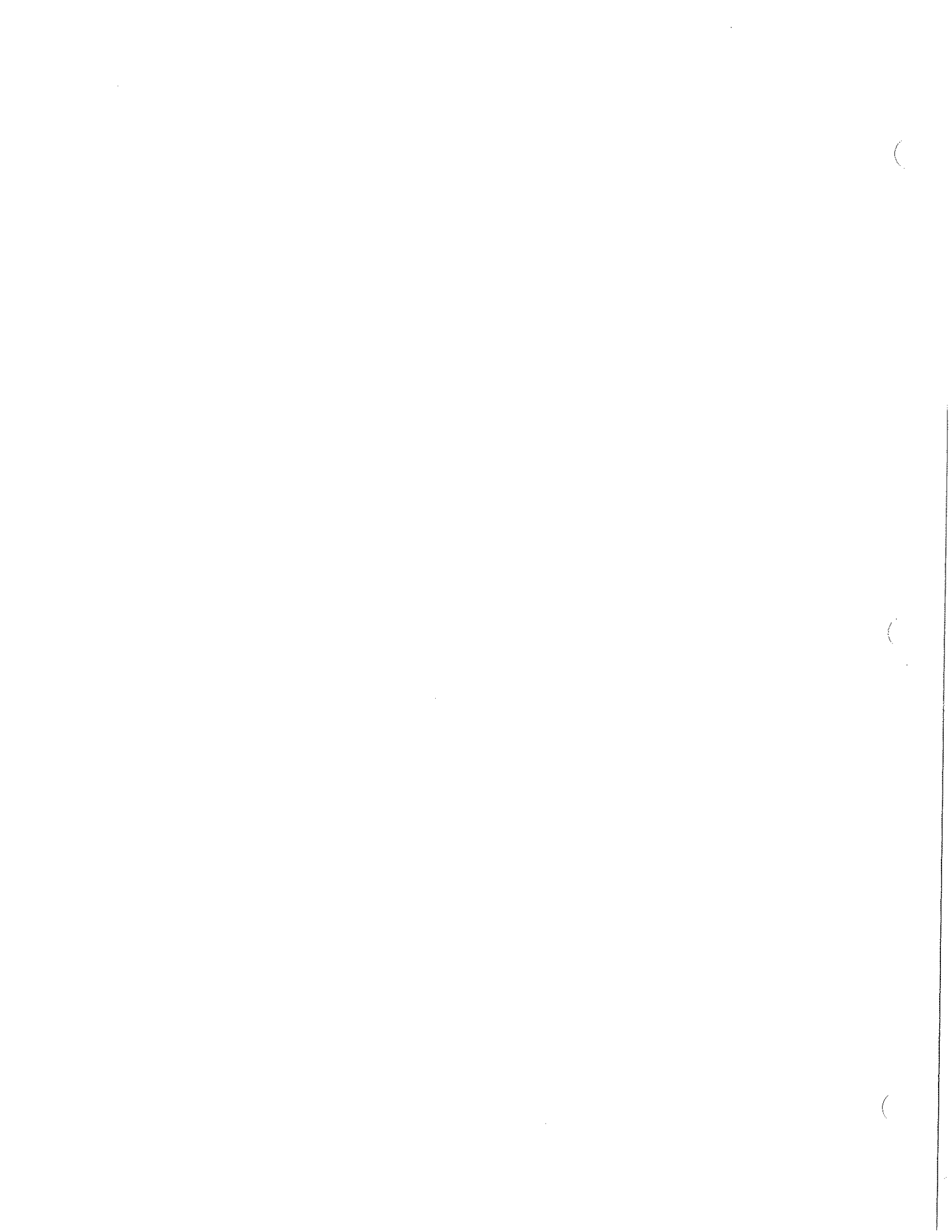

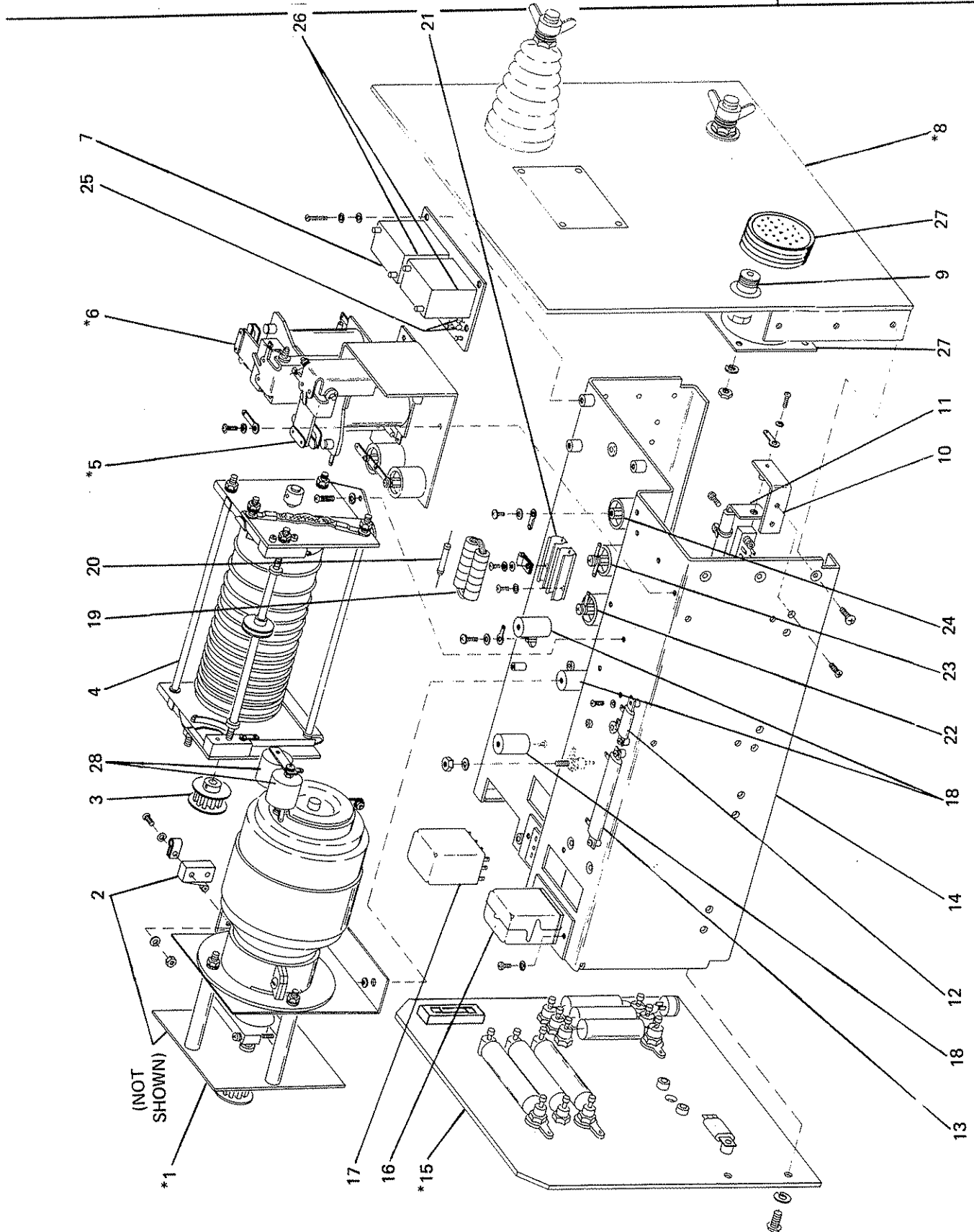

Figure 6.1 Chassis, Exploded View A

(

(

(

CHASSIS, EXPLODED VIEW A FIGURE 6.1

| ITEM NO. | REF. DESG. | DESCRIPTION | SUNAIR PART NUMBER |
|----------|-------------|--------------------------------|--------------------|
| 1 | C1 | *C1 Assy. | 6035080090 |
| 2 | S1, S2 | Switch, Micro, SPDT | 0345560001 |
| 3 | | Pulley, Timing, 11 Grooves | 0841430004 |
| 4 | L4 | Inductor, Var. 0.2-18.0 uh | 8033319607 |
| 5 | K2 | *Relay, SPST, 24V, HV 200ma | 6035079008 |
| 6 | K3 | *Relay, SPST, 24V, HV 200ma | 6035079008 |
| 7 | 2A5 | PC Assy. Relay Control | 6035050093 |
| 8 | | *Front Panel Assy. | 6035141358 |
| 9 | J2 | Connector, RF, N UG-680/U | 0756030005 |
| 10 | | Bracket, Hinged | 6035143300 |
| 11 | | Bracket, Connector | 6035143202 |
| 12 | R1 | Resistor, 50, 5%, 10W | 0188510001 |
| 13 | R2 | Resistor, 3, 5%, 20W | 0197390005 |
| 14 | | Chassis | 6035143008 |
| 15 | | *Rear Panel Assy. | 6035141196 |
| 16 | K1 | Relay, 4 PDT, 24V, Plug-In 3A | 0666880000 |
| 17 | K4 | Relay, 4 PDT, 24V, Plug-In 3A | 0666880000 |
| 18 | | Standoff, F-F, 6-32 - 690L | 6035142109 |
| 19 | T1 | Transformer, 50 ohm - 12.5 ohm | 6035142001 |
| 20 | R10 | Resistor, 1K, 5%, 5W | 0190370009 |
| 21 | | Clip, Component | 0508180007 |
| 22 | C6C | Capacitor, 100pf, 5KV, N750 | 0290440009 |
| 23 | C6B | Capacitor, 100pf, 5KV, N750 | 0290440009 |
| 24 | C6A | Capacitor, 100pf, 5KV, N750 | 0290440009 |
| 25 | 2A5, R1, R2 | Resistor, 3.3K, 10%, 1/4W | 0170890007 |
| 26 | 2A5, K1, K2 | Relay, SPST, 12V, Bistable | 0668340002 |
| 27 | J1 (P1) | Connector, Power, 37 Pin Round | 0747520003 |
| 28 | C3, A, B | Capacitor, 100pf, 5KV, N750 | 0290440009 |

* See exploded view of this item for further detailed information.

(

(

(

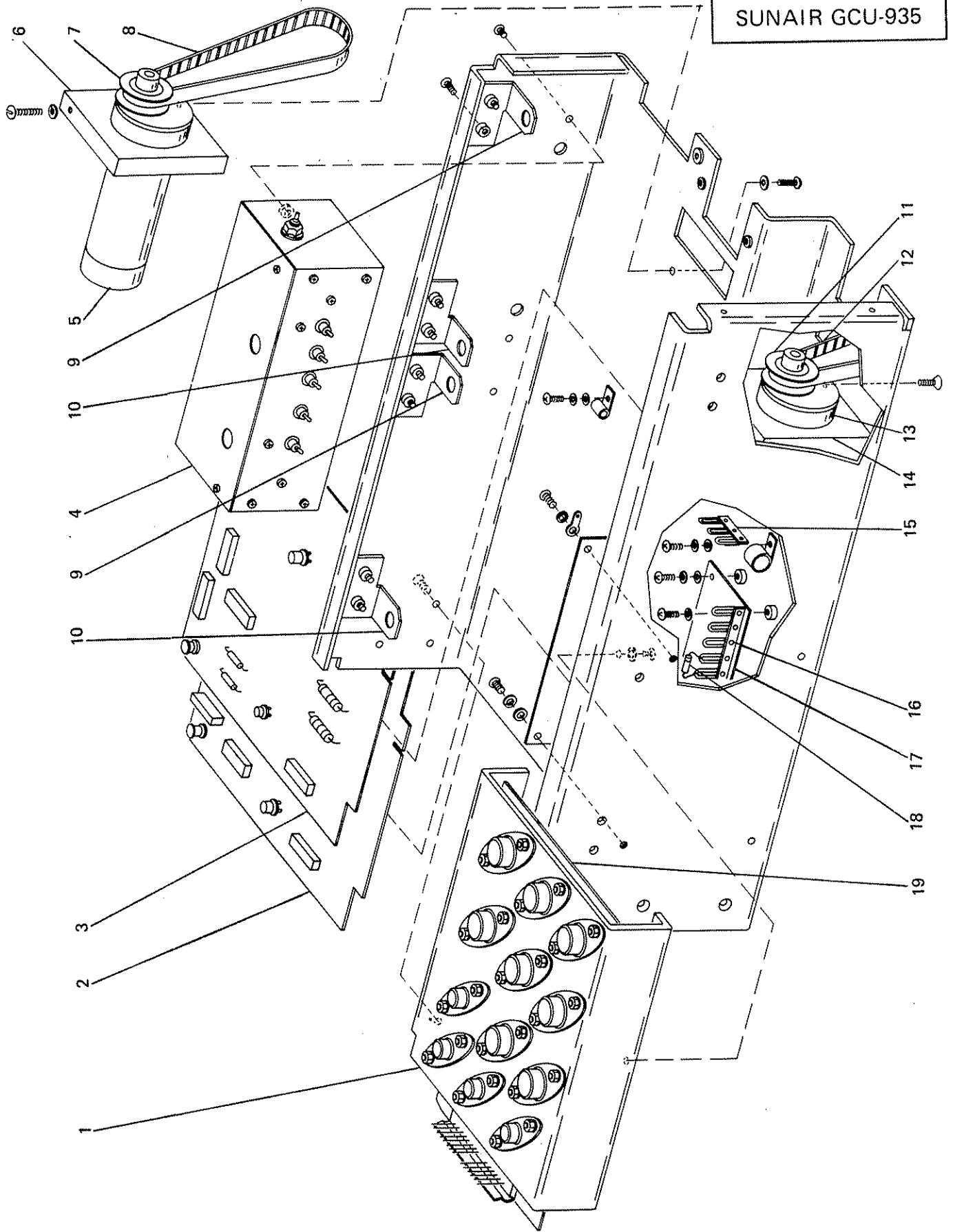

Figure 6.2 Chassis, Exploded View B

(

(

(

CHASSIS, EXPLODED VIEW B FIGURE 6.2

| ITEM NO. | REF. DESG. | DESCRIPTION | SUNAIR PART NUMBER |
|----------|------------|--------------------------------|--------------------|
| 1 | | Chassis, Servo Amplifier | 6035060099 |
| 2 | 2A1 | PC Assy. Control Logic | 6035010083 |
| 3 | 2A2 | PC Assy. Phase and Ampl. Ctrl. | 6035020089 |
| 4 | 2A4 | PC Assy. Phase and Ampl. Det. | 6035045693 |
| 5 | M2 | Motor, Torque, DC, 19.1V | 0346510007 |
| 6 | | Bracket, Motor Mtg. | 6035141501 |
| 7 | | Pulley, Timing, 11 Grooves | 0841440000 |
| 8 | | Belt, Timing | 0841420009 |
| 9 | | Bracket, Support | 6035142121 |
| 10 | | Bracket, Support | 6035143113 |
| 11 | | Pulley, Timing, 11 Grooves | 0841440000 |
| 12 | | Belt, Timing | 0841450005 |
| 13 | M1 | Motor, Torque, DC, 19.1V | 0346510007 |
| 14 | | Bracket, Motor Mtg. | 6035141501 |
| 15 | | Terminal Strip, 3 Term, 1 GND | 0996700056 |
| 16 | | Terminal Strip, 5 Term, 1 GND | 0996700099 |
| 17 | 2A3 | PC Assy. Regulator | 6035030092 |
| 18 | CR4 | Diode, Rectifier 1N4004 | 0405180004 |
| 19 | 2A6 | PC Assy. Servo Control | 6035060099 |

(

(

(

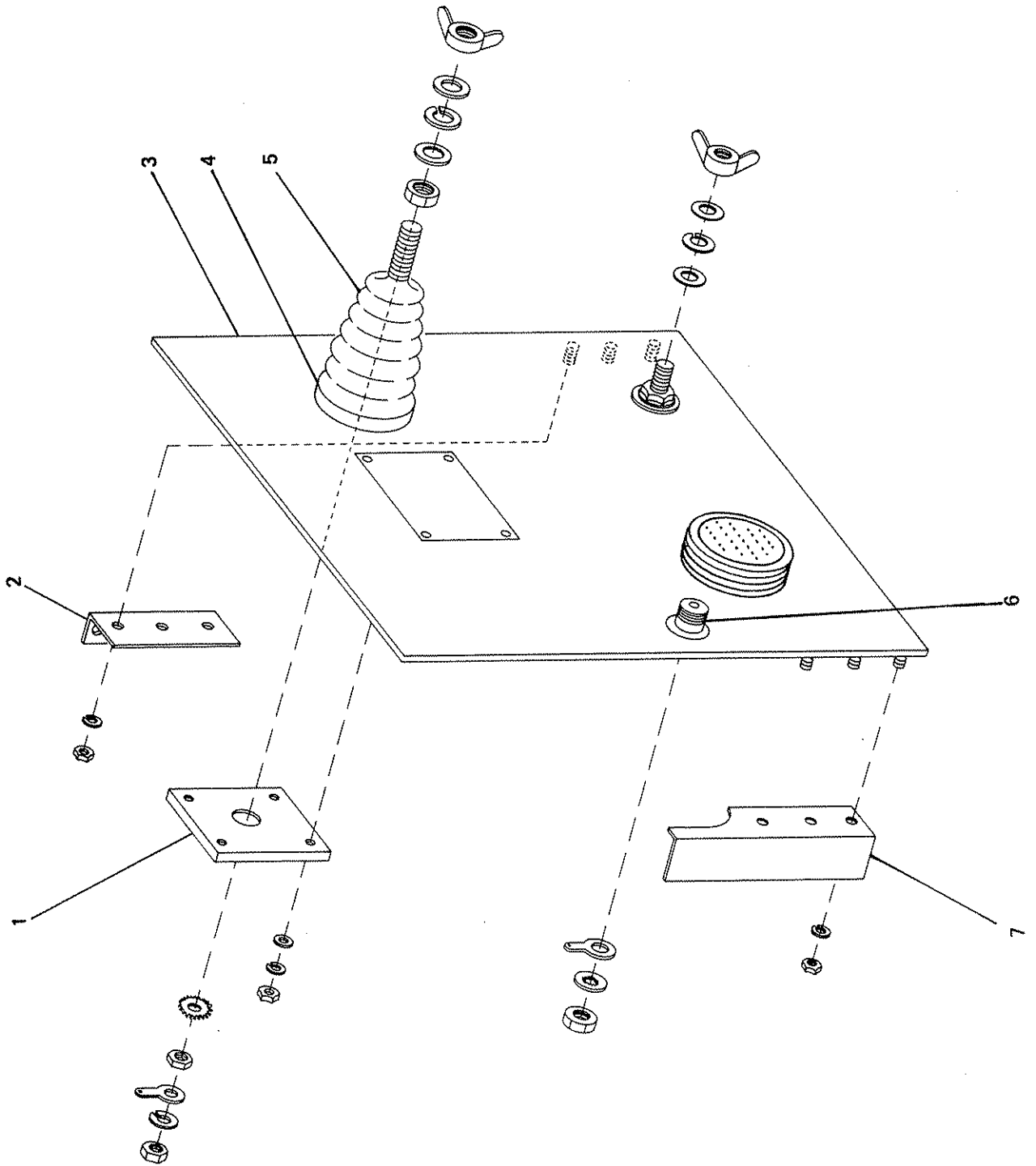

Figure 6.3 Front Panel Assembly

(

(

(

FRONT PANEL ASSY. FIGURE 6.3

| ITEM NO. | REF. DESG. | DESCRIPTION | SUNAIR PART NUMBER |
|----------|------------|------------------------------|--------------------|
| 1 | | Front Panel Assy. | 6035141358 |
| 2 | | Washer, Insulating | 6035141200 |
| 3 | | Bracket, Support, Right side | 6035143601 |
| 4 | | Panel, Front | 6035143903 |
| 5 | E1 | Gasket, Feedthru Insulator | 6035141706 |
| 6 | J2 | Insulator | 6035140904 |
| 7 | | Connector, RF, N UG-680/U | 0756030005 |
| | | Bracket, Support, Left side | 6035143504 |

(

(

(

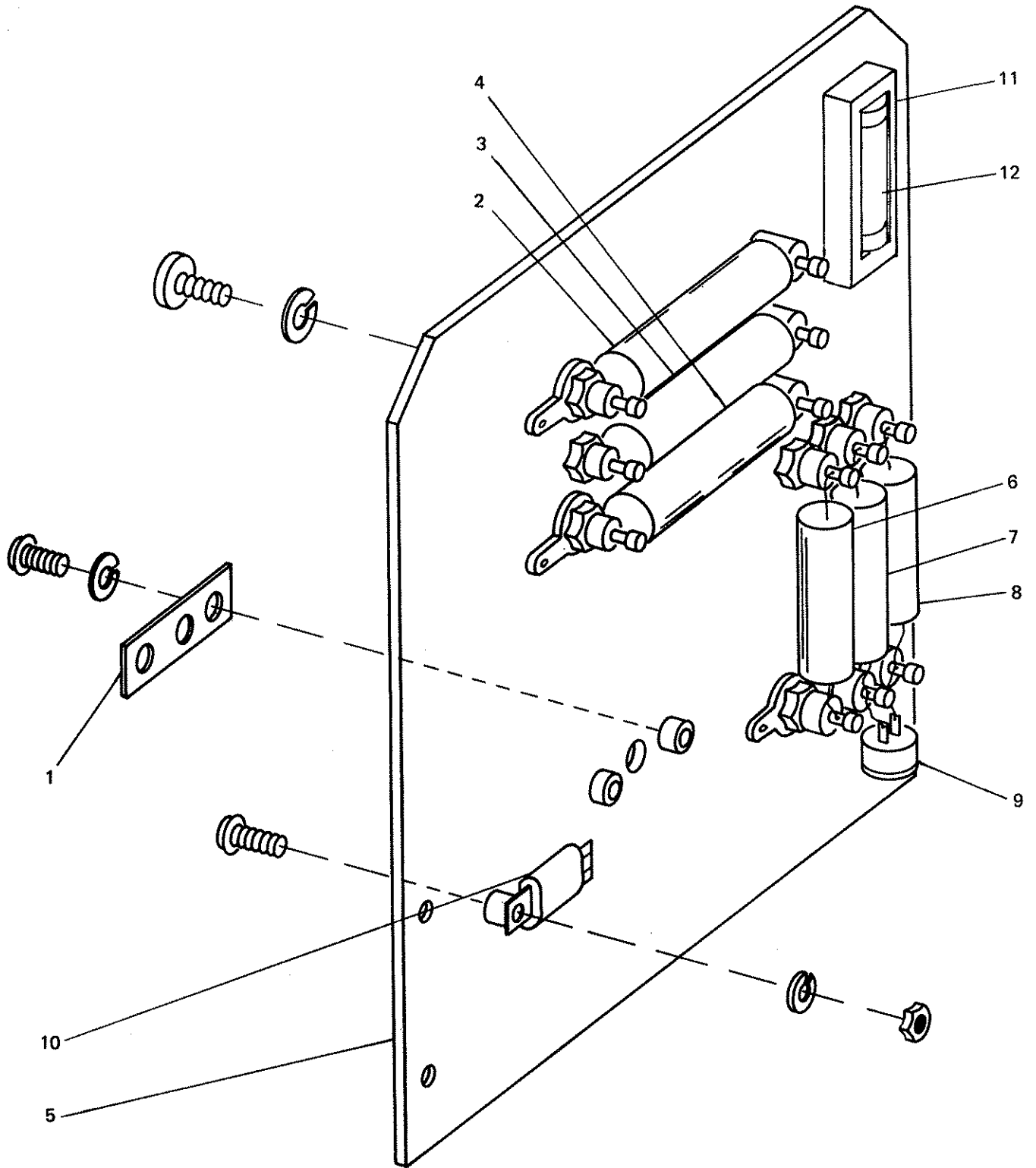

Figure 6.4 Rear Panel Assembly

(

(

(

REAR PANEL ASSY. FIGURE 6.4

| ITEM NO. | REF. DESG. | DESCRIPTION | SUNAIR PART NUMBER |
|----------|------------|---------------------------------|--------------------|
| | | Rear Panel Assy. | 6035141196 |
| 1 | | Block, Alignment | 6035143709 |
| 2 | R8 | Resistor, 400, 5%, 14W | 0197380000 |
| 3 | R7 | Resistor, 400, 5%, 14W | 0197380000 |
| 4 | R6 | Resistor, 200, 5%, 14W | 0197410006 |
| 5 | | Panel, Rear | 6035143709 |
| 6 | R3 | Resistor, 75, 5%, 14W | 0191300004 |
| 7 | R4 | Resistor, 75, 5%, 14W | 0191300004 |
| 8 | R5 | Resistor, 75, 5%, 14W | 0191300004 |
| 9 | C2 | Capacitor, 15-60pf, 200V, N1500 | 0252680006 |
| 10 | R9 | Resistor, 15, 5%, 10W | 0197420001 |
| 11 | | Fusemount, 1 Pole w/Terminals | 0842490001 |
| 12 | F1 | Fuse, AGC, 5 AMP, 32V | 0848980000 |

(

(

(

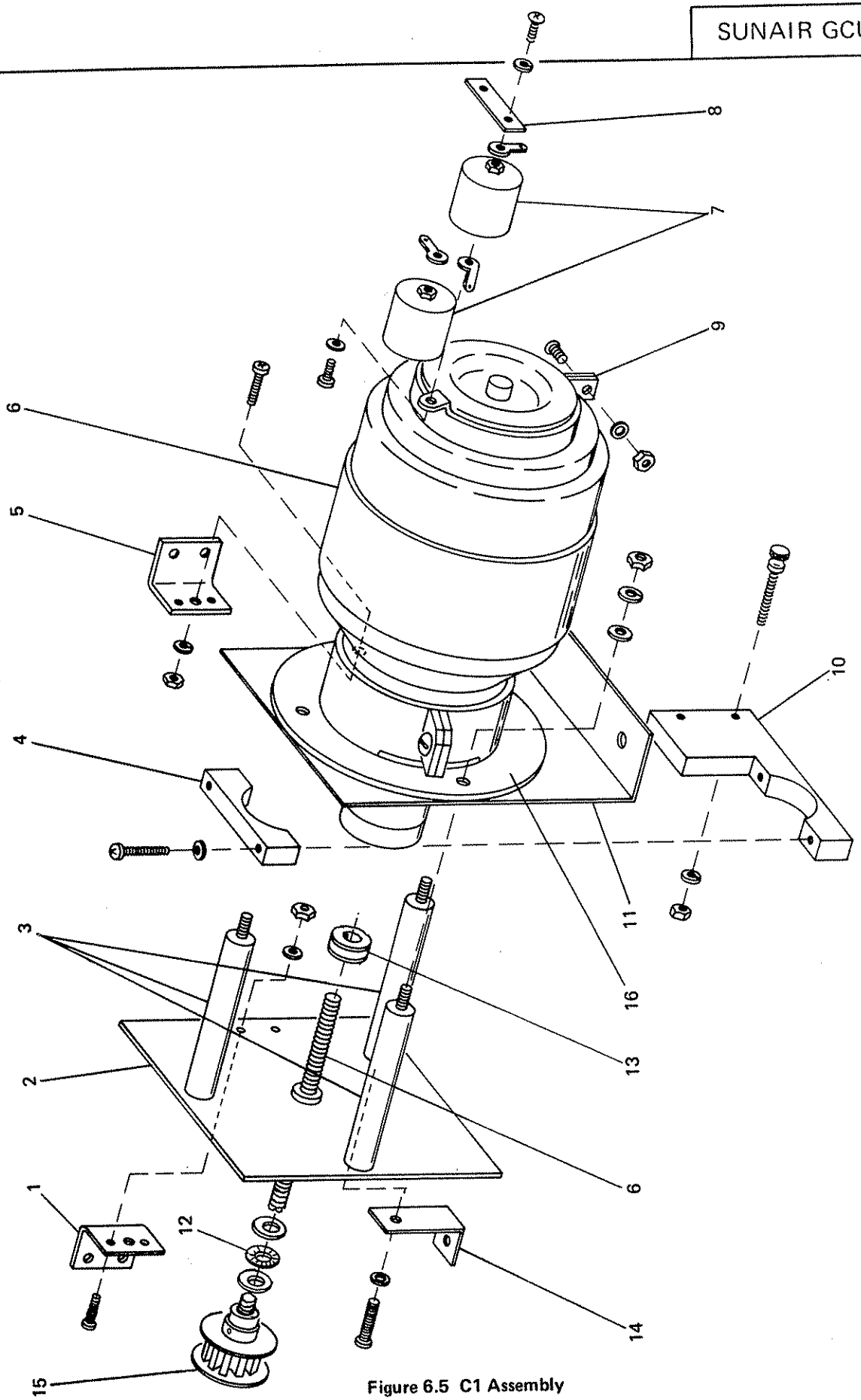

Figure 6.5 C1 Assembly

(

(

(

C1 ASSY. FIGURE 6-5

| ITEM NO. | REF. DESG. | DESCRIPTION | SUNAIR PART NUMBER |
|----------|------------|---------------------------------|--------------------|
| | | C1 Assy. | 6035080090 |
| 1 | | Plate, Switch Mtg. Var. Cap. | 6035081207 |
| 2 | | Plate, End Var. Cap... | 6035081401 |
| 3 | | Standoff, M-F, 8-32 2.00L | 0542720001 |
| 4 | | Plate, Limit Adj. Top Cap. | 6035081100 |
| 5 | | Plate, Switch Mtg. Var. Cap. | 6035081207 |
| 6 | C1 | Capacitor, Var. Vacuum | 6035080707 |
| 7 | C3, A, B | Capacitor, 100pf, 5KV, N750 | 0290440009 |
| 8 | | Bracket, Cap. Coupling | 6035082203 |
| 9 | | Clamp, Var. Cap. | 6035082009 |
| 10 | | Plate, Limit Adj. Var. Cap. | 6035081002 |
| 11 | | Bracket, Support, Var. Cap. | 6035080804 |
| 12 | | Bearing, Thrust | 0841460001 |
| 13 | | Shaft Retainer, Vac Capacitor | 6035081606 |
| 14 | | Bracket, Rear Support Var. Cap. | 6035081304 |
| 15 | | Pulley, Timing, 11 Grooves | 0841430004 |
| 16 | | Mount, Flange | 6035081509 |

(

(

(

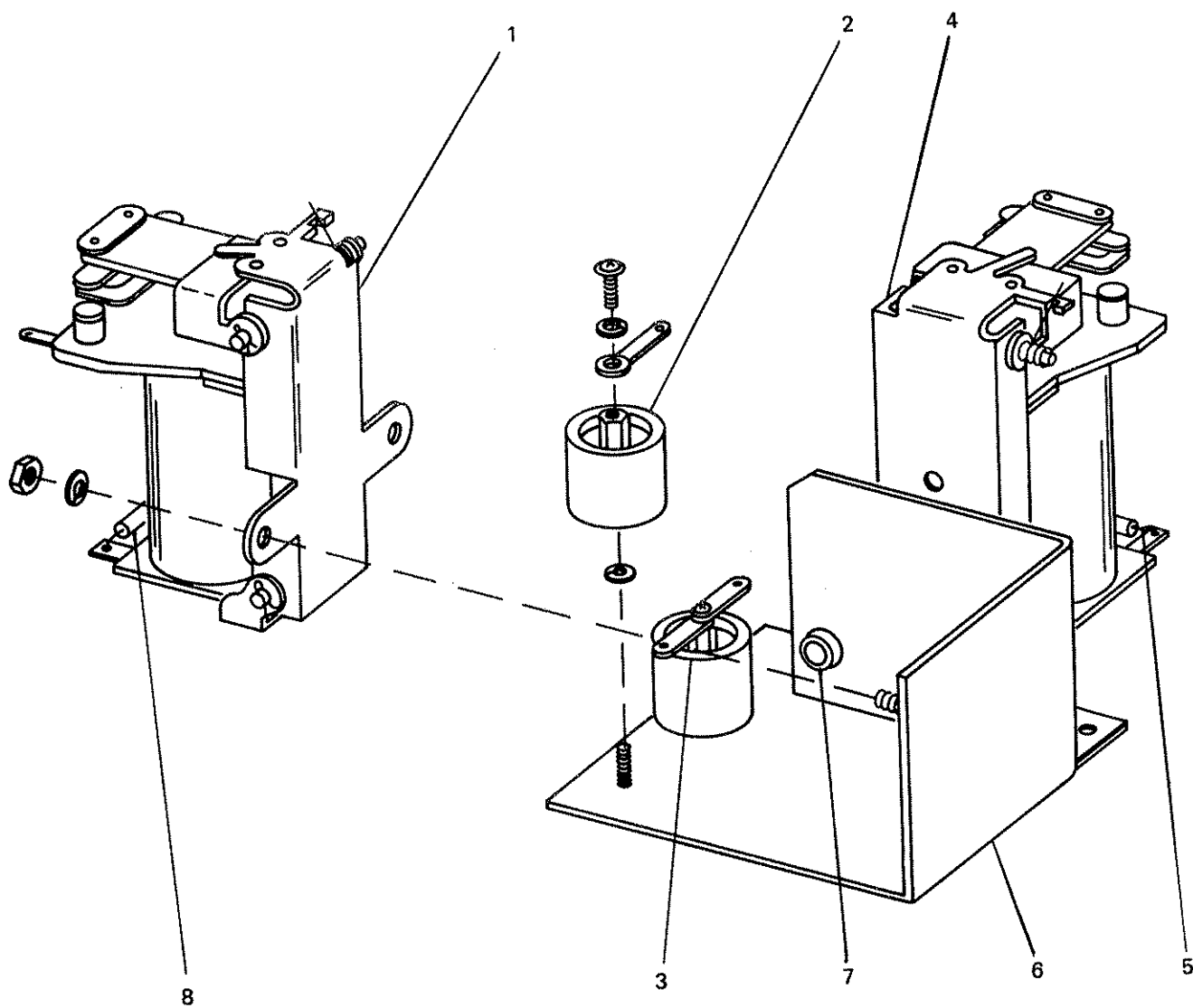
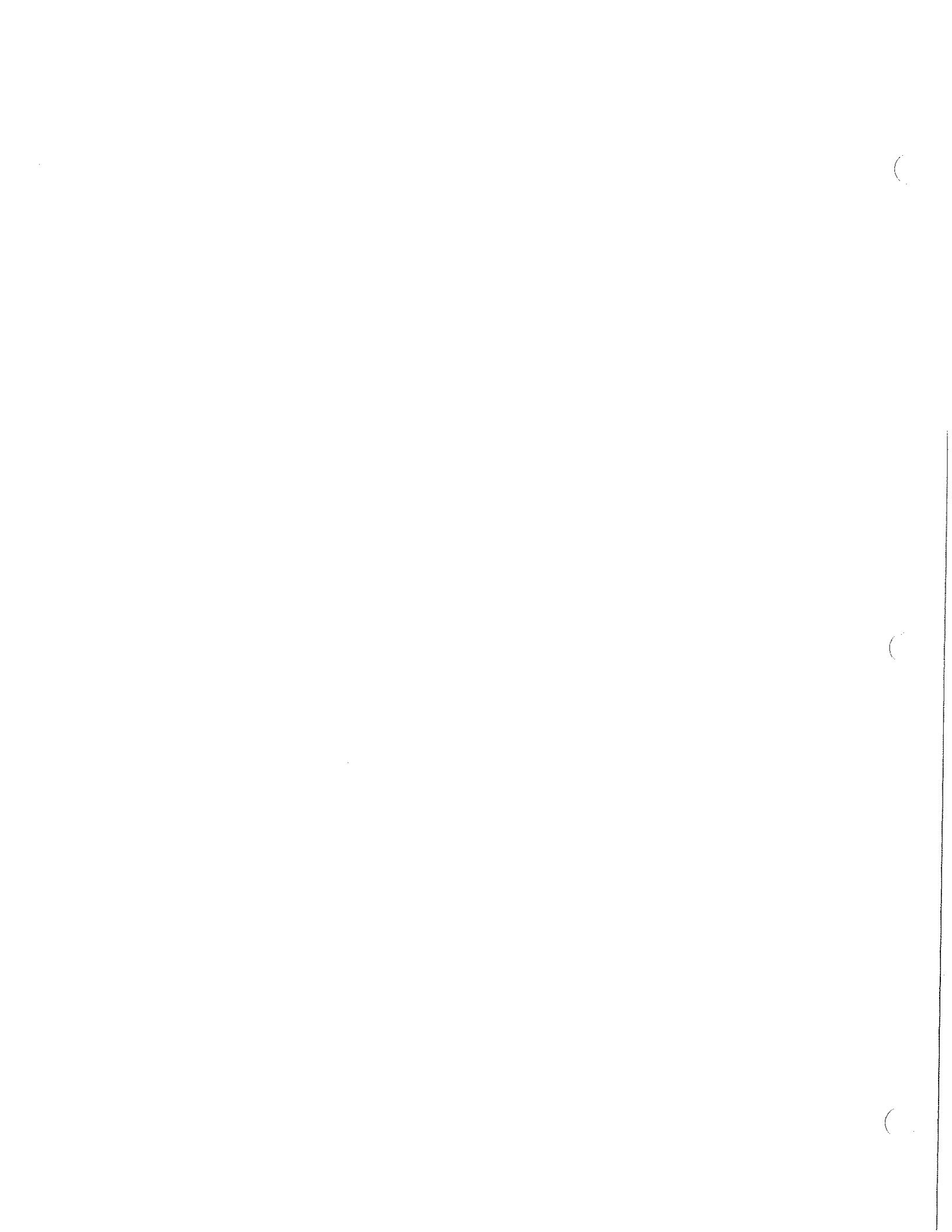

Figure 6.6 Relay Assembly K2 & K3



RELAY ASSY. K2 AND K3 FIGURE 6.6

| ITEM NO. | REF. DESG. | DESCRIPTION | SUNAIR PART NUMBER |
|----------|------------|-------------------------------|--------------------|
| | | Relay Assy. K2 & K3 | 6035070094 |
| 1 | K2 | Relay, SPST, 24V, HV200MA | 6035079008 |
| 2 | C6E | Cap. 100 pf, 5KV, N750 | 0290440009 |
| 3 | C6D | Cap. 100pf, 5KV, N750 | 0290440009 |
| 4 | K3 | Relay, SPST, 24V, HV200MA | 6035079008 |
| 5 | CR6 | Diode, Rectifier 1N4004 | 0405180004 |
| 6 | | Bracket, Relay Mtg. | 6035079504 |
| 7 | | Grommet, Rubber,.125 1D.344OD | 0500510008 |
| 8 | CR5 | Diode, Rectifier 1N4004 | 0405180004 |

(

(

(

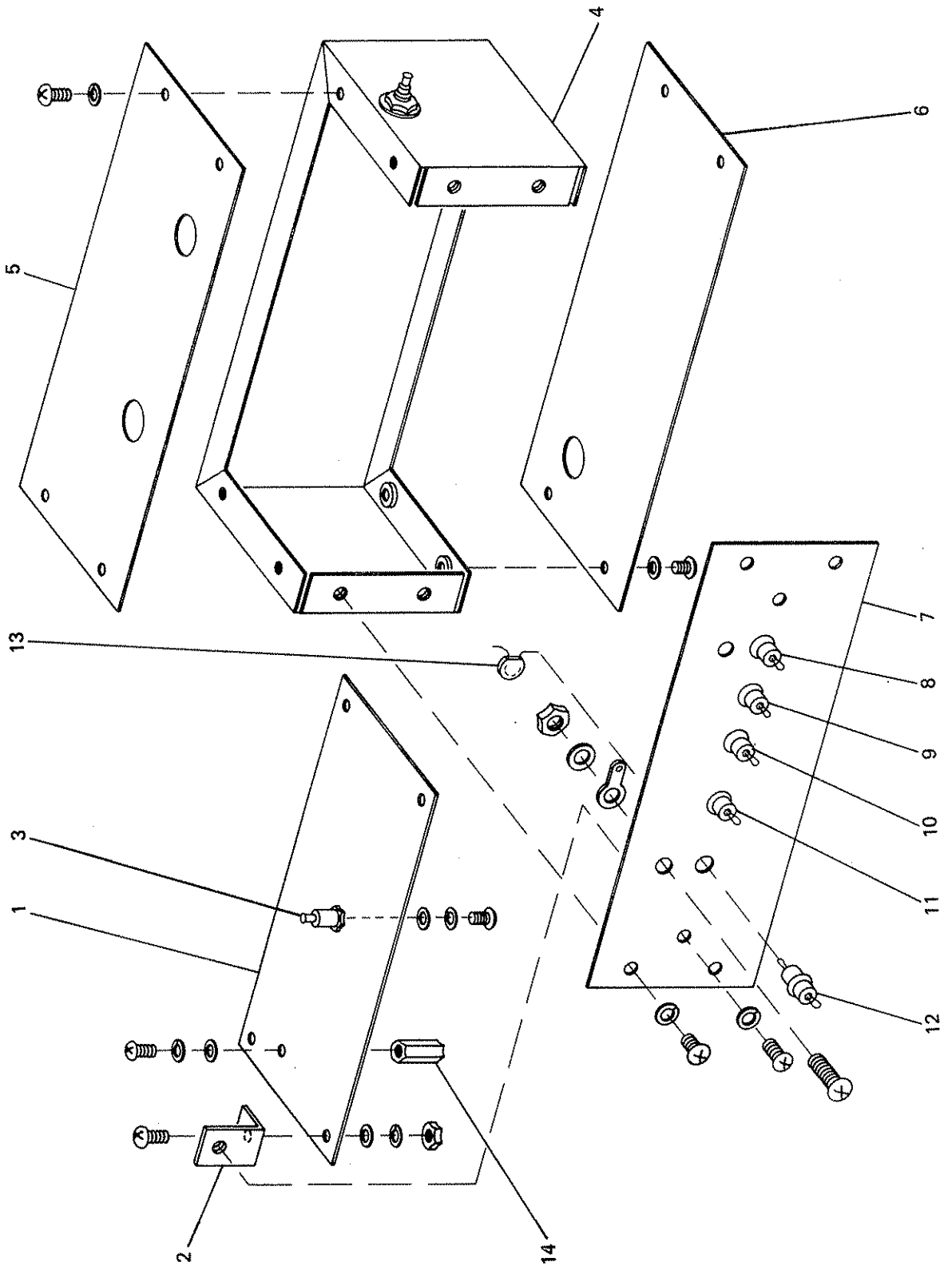

Figure 6.7 PC Assembly Phase and Amplitude Detector

(

(

(

PC ASSY. PHASE AND AMPLITUDE DETECTOR FIGURE 6-7

| ITEM NO. | REF. DESG. | DESCRIPTION | SUNAIR PART NUMBER |
|----------|--------------|----------------------------------|--------------------|
| 1 | | PCB Phase and Amplitude Detector | 6035045502 |
| 2 | | Bracket, Phase Detector | 6035046002 |
| 3 | | Terminal, Insul. 4-40 Female | 0506390004 |
| 4 | | Frame, Phase Detector | 6035048102 |
| 5 | | Panel, Bottom Phase Detector | 6035048200 |
| 6 | | Panel, Top, Phase Detector | 6035048404 |
| 7 | | Cover, Phase Detector | 6035048307 |
| 8 | C17 | Capacitor, 1000pf | 0258660007 |
| 9 | C19 | Capacitor, 1000pf | 0258660007 |
| 10 | C18 | Capacitor, 1000pf | 0258660007 |
| 11 | C20 | Capacitor, 1000pf | 0258660007 |
| 12 | C21 | Capacitor, 1000pf | 0258660007 |
| 13 | C12 thru C16 | Capacitor, 0.01uf, 100V, Z5V | 0273210009 |
| 14 | | Standoff, F-F, 2-56 .750L | 0508810001 |

(

(

(

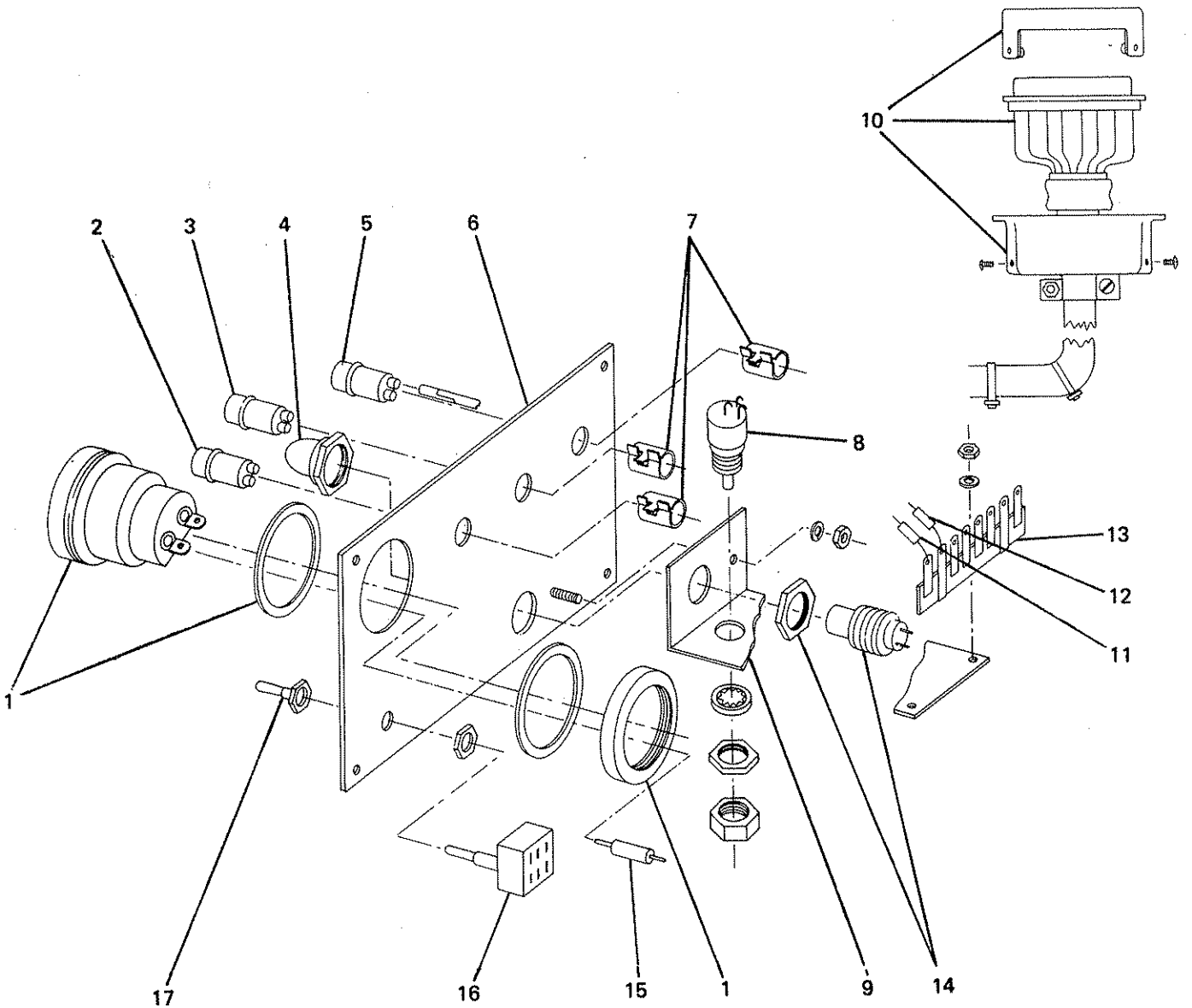

Figure 6.8 Coupler Tuning Control

(

(

(

COUPLER TUNING CONTROL FIGURE 6.8

| ITEM NO. | REF. DESG. | DESCRIPTION | SUNAIR PART NUMBER |
|----------|------------|--|----------------------------------|
| | | Coupler Tuning Control | 6035150055 Gry 6035150098 Grn |
| 1 | M1 | Meter | 5024042204 |
| 2 | DS2 | Lamp Assy. Red | 0841490007 |
| 3 | DS3 | Lamp Assy. Amber | 0841500002 |
| 4 | | Boot, Pushbutton Switch 1/2-40 | 0346530008 |
| 5 | DS1 | Lamp Assy. Green | 0841480001 |
| 6 | | Panel, Control | 6035150501 Grn 6035150519 Gry |
| 7 | | Clip, Lamp Assy. Mtg. | 0841510008 |
| 8 | R2 | Potentiometer, 10K, 10%, 3/4W, 1/8 shaft | 0335900003 |
| 9 | | Bracket, Term. Strip Mtg. | 6035150705 |
| 10 | P1 | Connector, Power, 36 Pin Rect. | 0754070000 |
| 11 | R1 | Resistor, 10K, 10%, 1/4W | 0170410005 |
| 12 | R3 | Resistor, 15K, 10%, 1/4W | 0173250000 |
| 13 | | Terminal Strip, 8 Term. 2 Gnd. | 0859070000 |
| 14 | S2 | Switch, Pushbutton, SPST, N.O. | 0346520002 |
| 15 | P2 | Plug, Phone Tip, Red | 0753680009 |
| 16 | S1 | Switch, Toggle DPDT | 0334610001 |
| 17 | | Boot, Toggle Switch, 1/4-40 | 0531120007 |

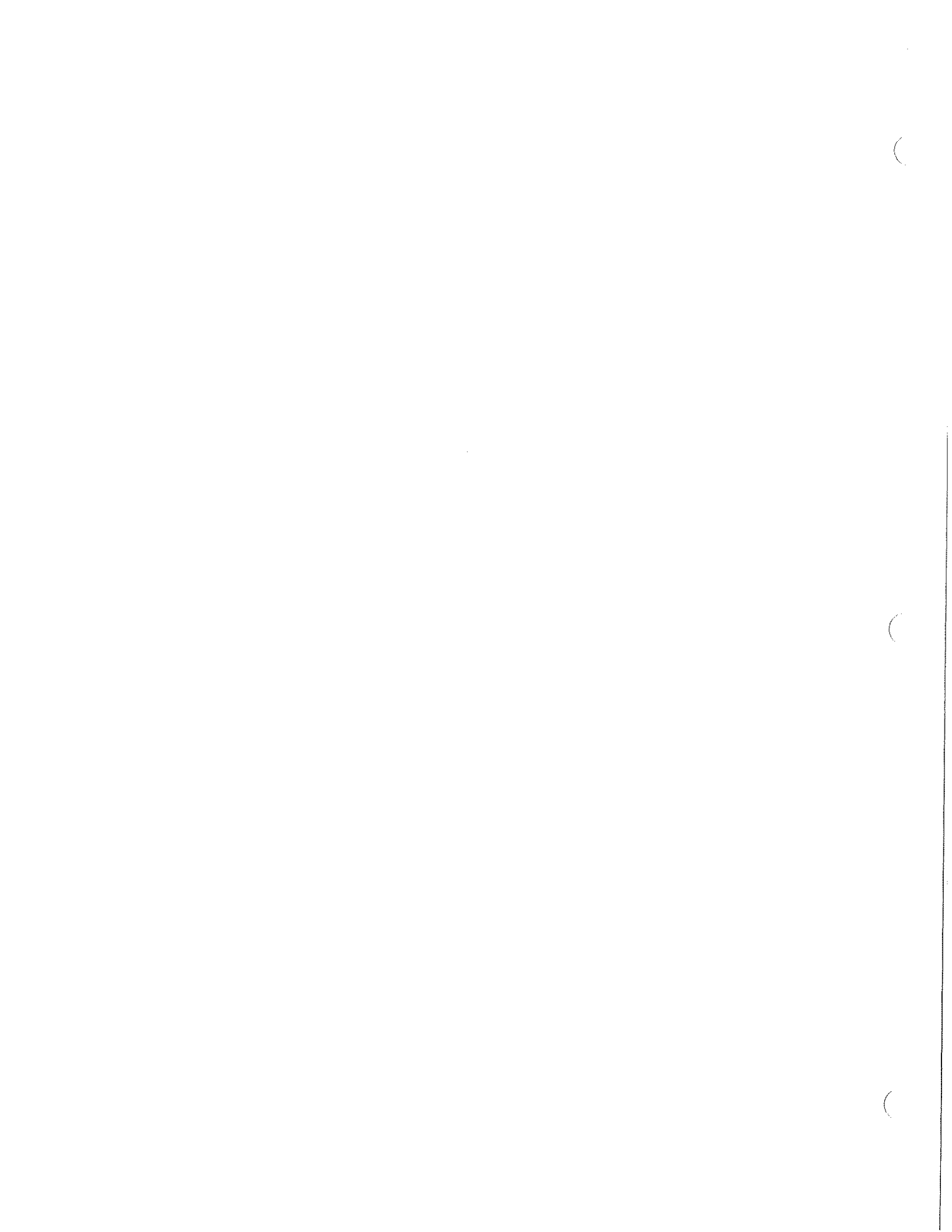

SECTION VII

PHOTOGRAPHIC CALLOUTS

7.1 This section has been designed to aid you in your maintenance and repair of your GCU-935.

The GCU-935 has been photographed from all angles and all major assemblies and chassis components have been called out.

| DESIGNATOR | DESCRIPTION | SUNAIR PART NUMBER |
|------------|---------------------------------|--------------------|
| C1 | Capacitor, Var, Vacuum | 6035080707 |
| C2 | Capacitor, 15-60pf, 200V, N1500 | 0252680006 |
| C3A | Capacitor, 100pf, 5KV, N750 | 0290440009 |
| C3B | Capacitor, 100pf, 5KV, N750 | 0290440009 |
| C6A | Capacitor, 100pf, 5KV, N750 | 0290440009 |
| C6B | Capacitor, 100pf, 5KV, N750 | 0290440009 |
| C6C | Capacitor, 100pf, 5KV, N750 | 0290440009 |
| C6D | Capacitor, 100pf, 5KV, N750 | 0290440009 |
| C6E | Capacitor, 100pf, 5KV, N750 | 0290440009 |
| CMAX | Indicated as a reference only | |
| CMIN | Indicated as a reference only | |
| CR2 | Diode, Zener 1N2974B | 0405340001 |
| E1 | Insulator | 6035140904 |
| F1 | Fuse, AGC, 5 Amp, 32V | 0848980000 |
| J1(P1) | Connector, Power, 37 Pin Round | 0747520003 |
| J2 | Connector, RFN, UG-680/U | 0756030005 |
| K1 | Relay, 4PDT, 24V, Plug-In 3A | 0666880000 |
| K2 | Relay, SPST, 24V, HV 200MA | 6035079008 |
| K3 | Relay, SPST, 24V, HV, 200ma | 6035079008 |
| K4 | Relay, 4PDT, 24V, Plug-In 3A | 0666880000 |
| L4 | Inductor, Var. 0.2-18.0 uh | 8033319607 |
| LMAX | Indicated as a reference only | |
| LMIN | Indicated as a reference only | |
| M1 | Motor, Torque, DC, 19.1V | 0346510007 |
| M2 | Motor, Torque, DC, 19.1V | 0346510007 |

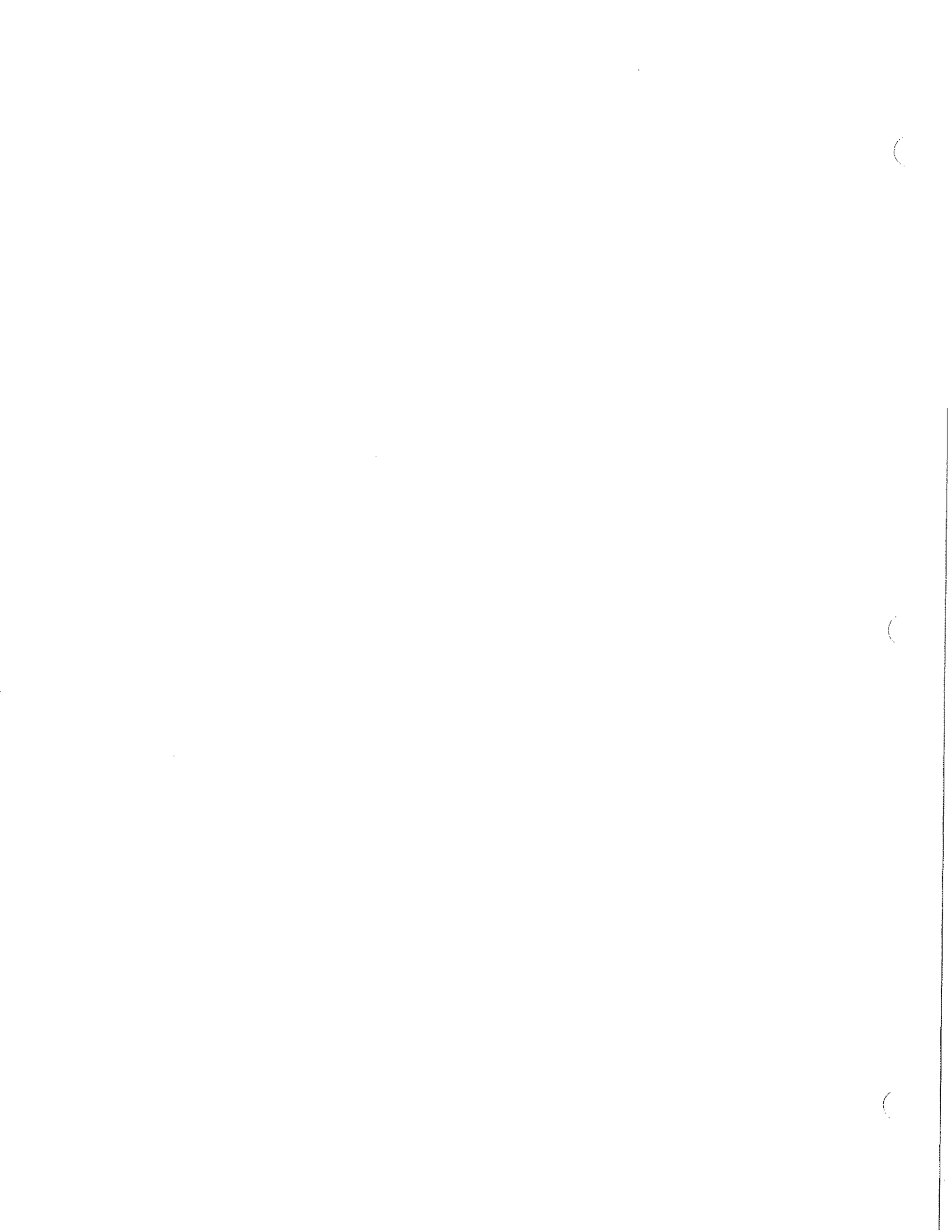

| DESIGNATOR | DESCRIPTION | SUNAIR PART NUMBER |
|------------|----------------------------------|--------------------|
| R1 | Resistor, 50, 5%, 10W | 0188510001 |
| R2 | Resistor, 3, 5%, 20W | 0197390005 |
| R3 | Resistor, 75, 5%, 14W | 0191300004 |
| R4 | Resistor, 75, 5%, 14W | 0191300004 |
| R5 | Resistor, 75, 5%, 14W | 0191300004 |
| R6 | Resistor, 200, 5%, 14W | 0197410006 |
| R7 | Resistor, 400, 5%, 14W | 0197380000 |
| R8 | Resistor, 400, 5%, 14W | 0197380000 |
| R10 | Resistor, 1K, 5%, 5W | 0190370009 |
| S1 | Switch, Micro, SPDT | 0345560001 |
| S2 | Switch, Micro, SPDT | 0345560001 |
| T1 | Transformer, 50 ohm-12.5 ohm | 6035142001 |
| 2A1 | PC Assy Control Logic | 6035010083 |
| 2A2 | PC Assy Phase and Ampl. Ctrl. | 6035020089 |
| 2A3 | PC Assy Regulator | 6035030092 |
| 2A3A | PC Assy Filter | 6035035094 |
| 2A4 | PC Assy Phase and Ampl. Detector | 6035045693 |
| 2A4C1 | Capacitor, 2-8pf, 200V, NPO | 0278400001 |
| 2A5 | PC Assy Relay Control | 6035050093 |
| 2A5K1 | Relay, SPST, 12V Bistable | 0668340002 |
| 2A6 | PC Assy Servo Control | 6035060099 |
| 2XA1 | Indicated as a reference only | |
| 2XA2 | Indicated as a reference only | |
| 2XA6 | Indicated as a reference only | |
| 2XK1 | Socket, Relay, 4PDT Contacts | 0767000005 |
| 2XK4 | Socket, Relay, 4PDT Contacts | 0767000005 |
| Grommet | Fastener, PC Board Grommet | 0508800005 |
| Plunger | Fastener, PC Board Plunger | 0508790000 |
| Wing Nut | Nut, Wing 1/4-20 | 0507730003 |

(

(

(

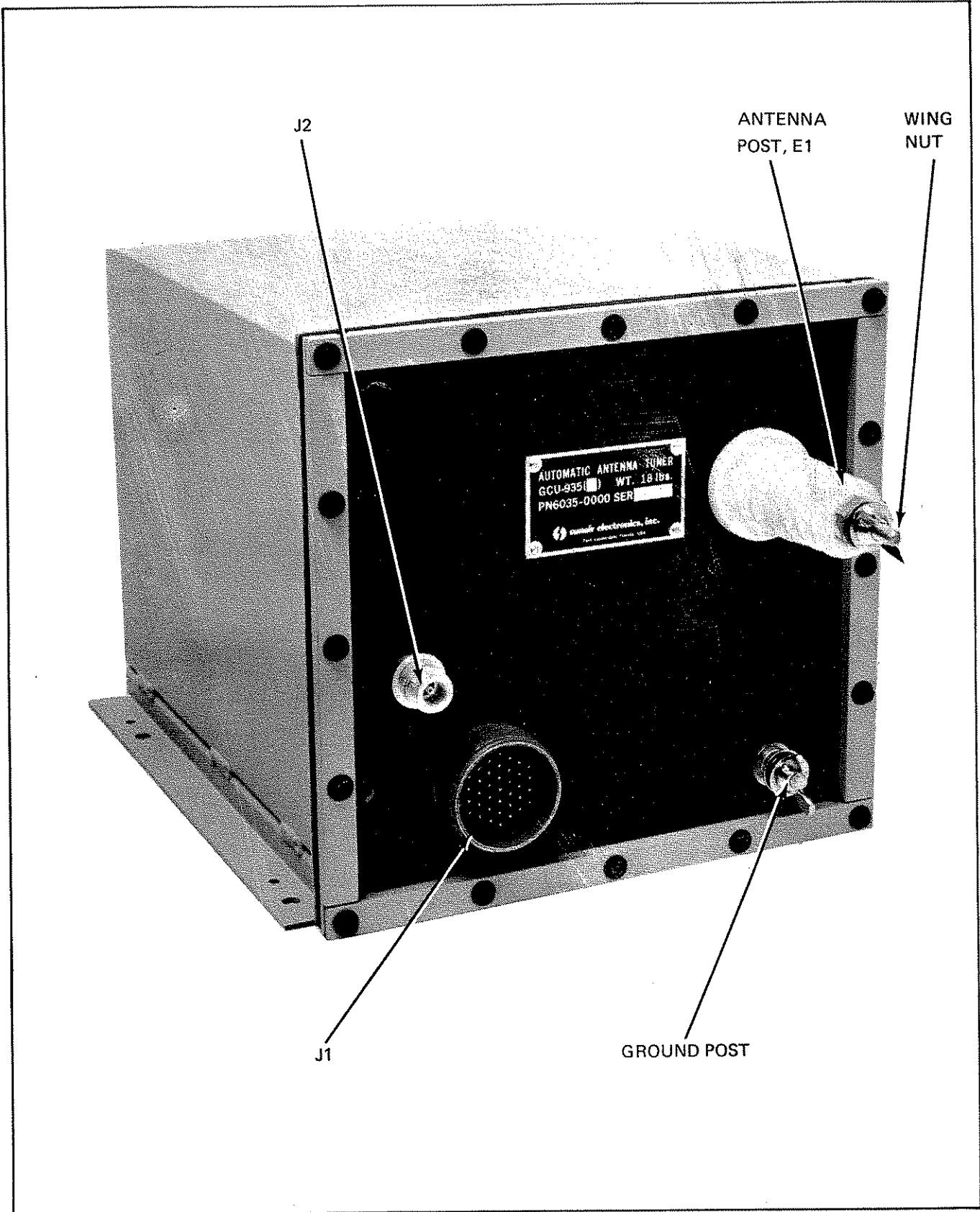

Figure 7.1 GCU-935 W/Cover

(

(

(

SUNAIR GCU-935

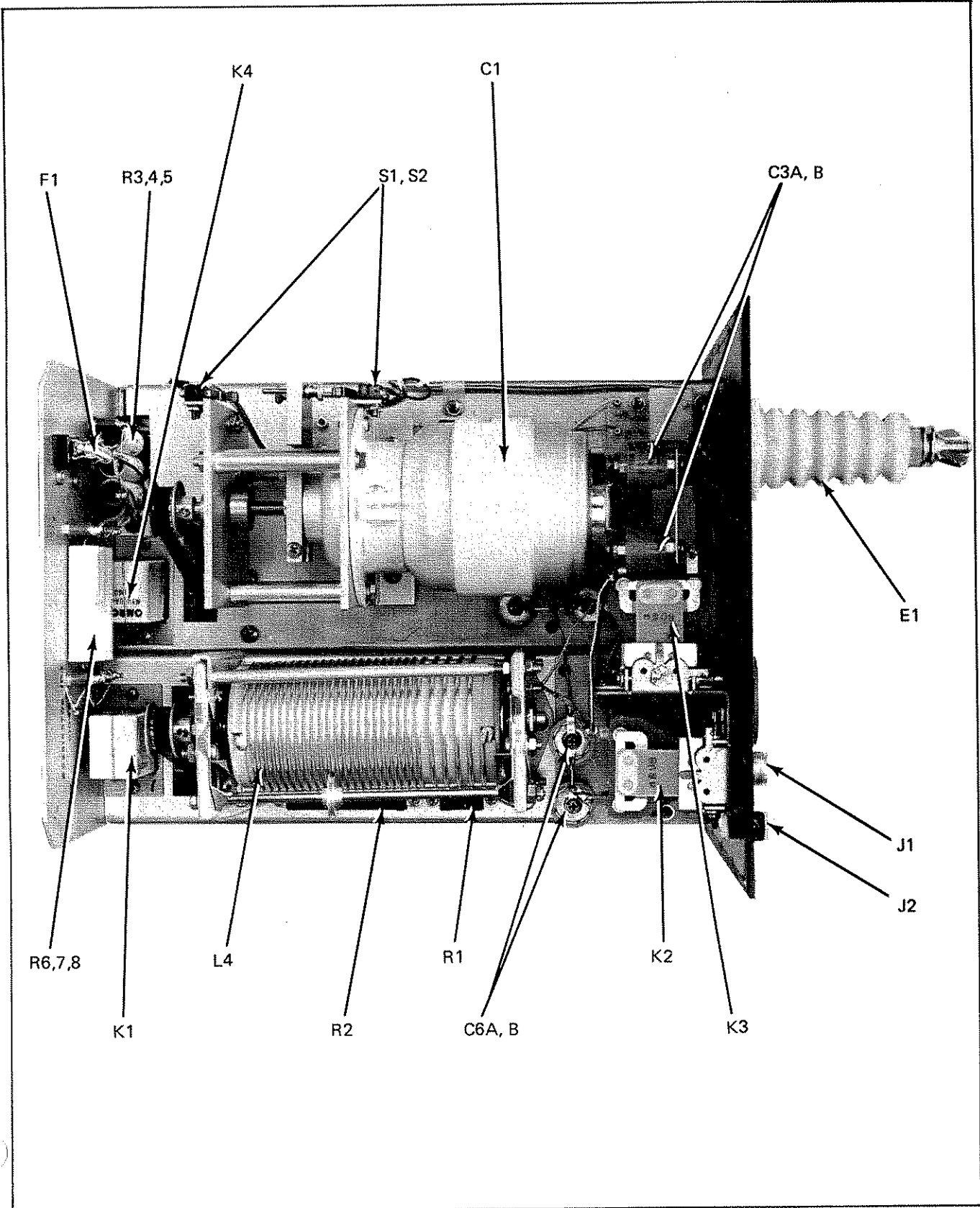

Figure 7.2 GCU-935 Top View

(

(

(

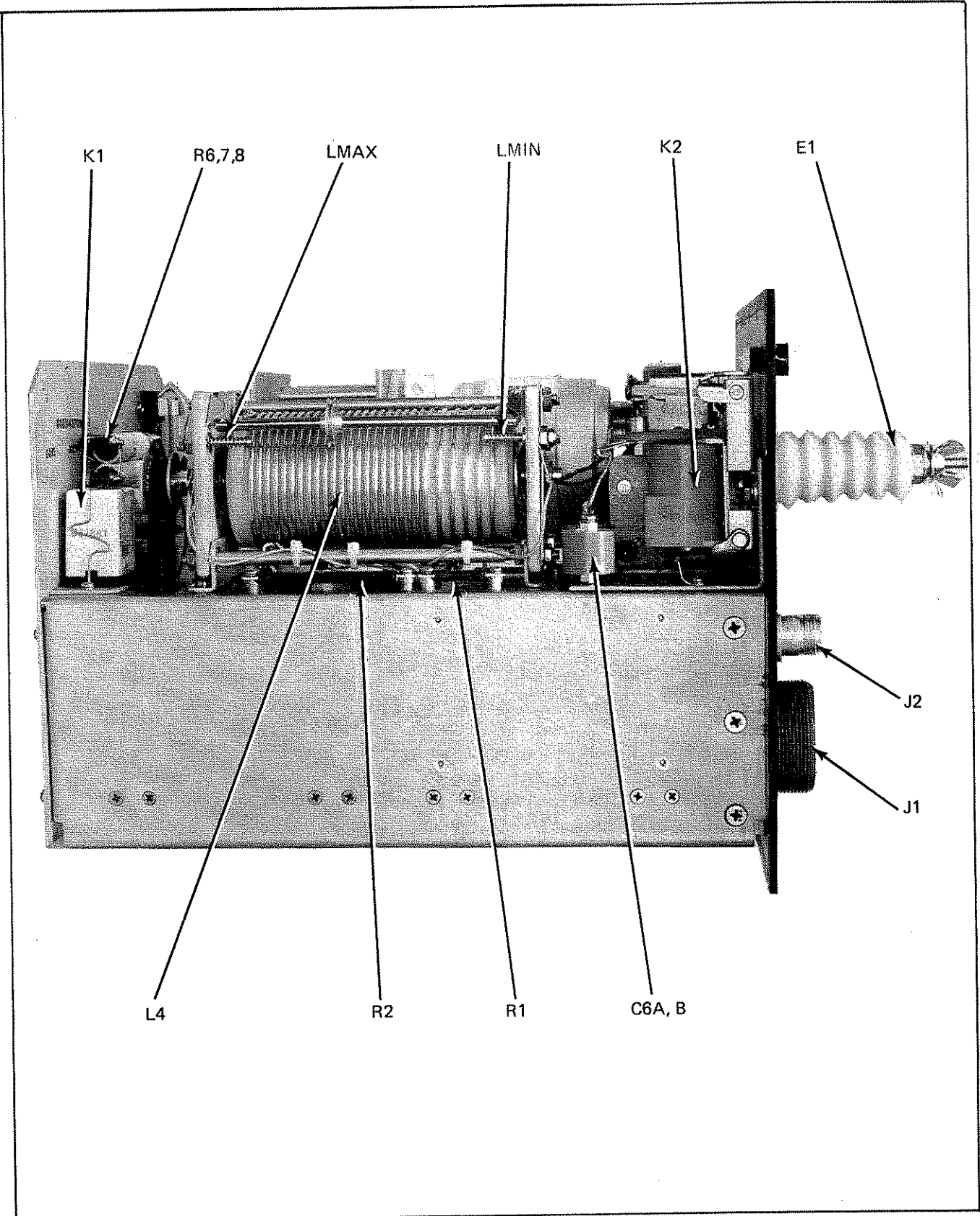

Figure 7.3 GCU-935 Left View

(

(

(

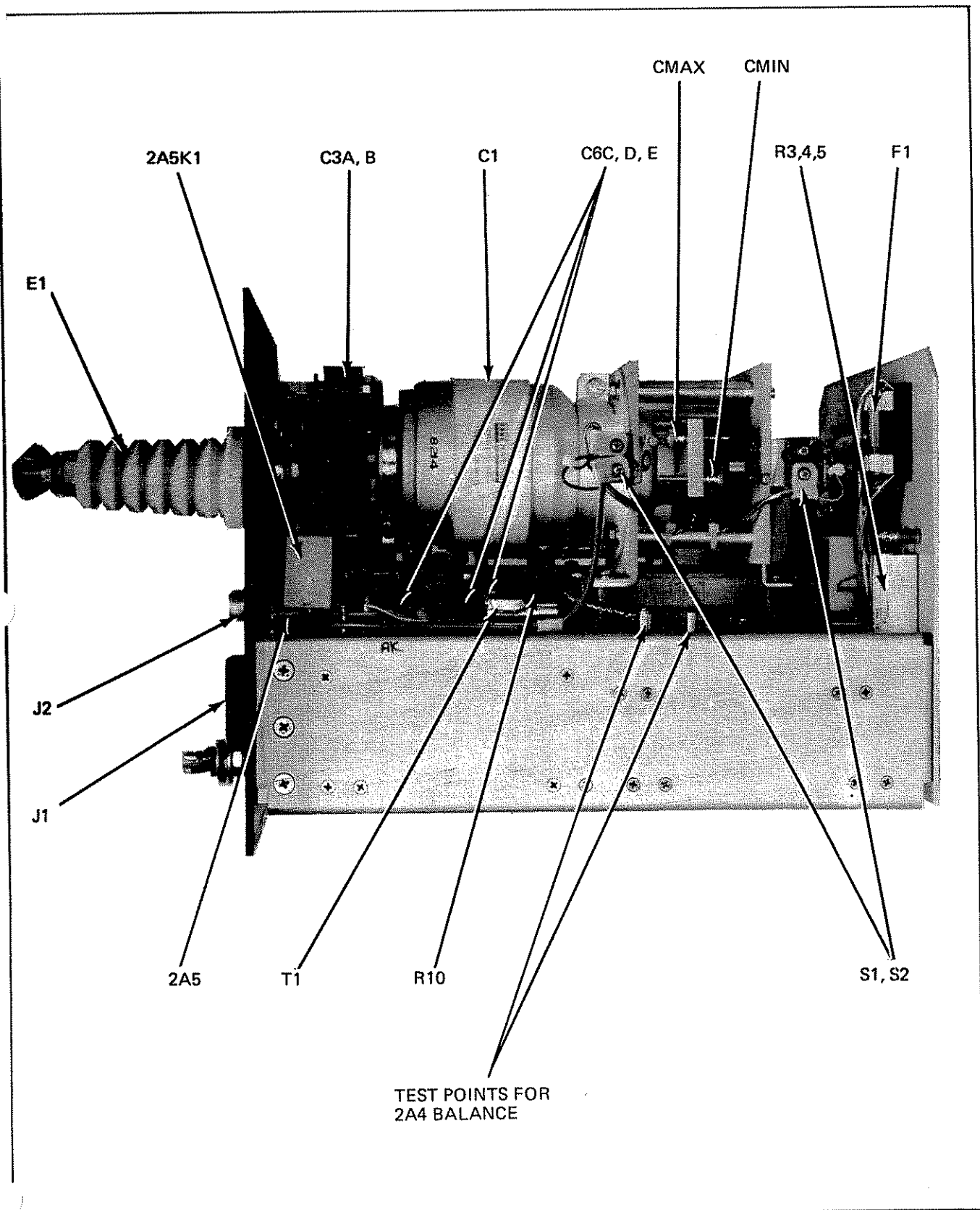
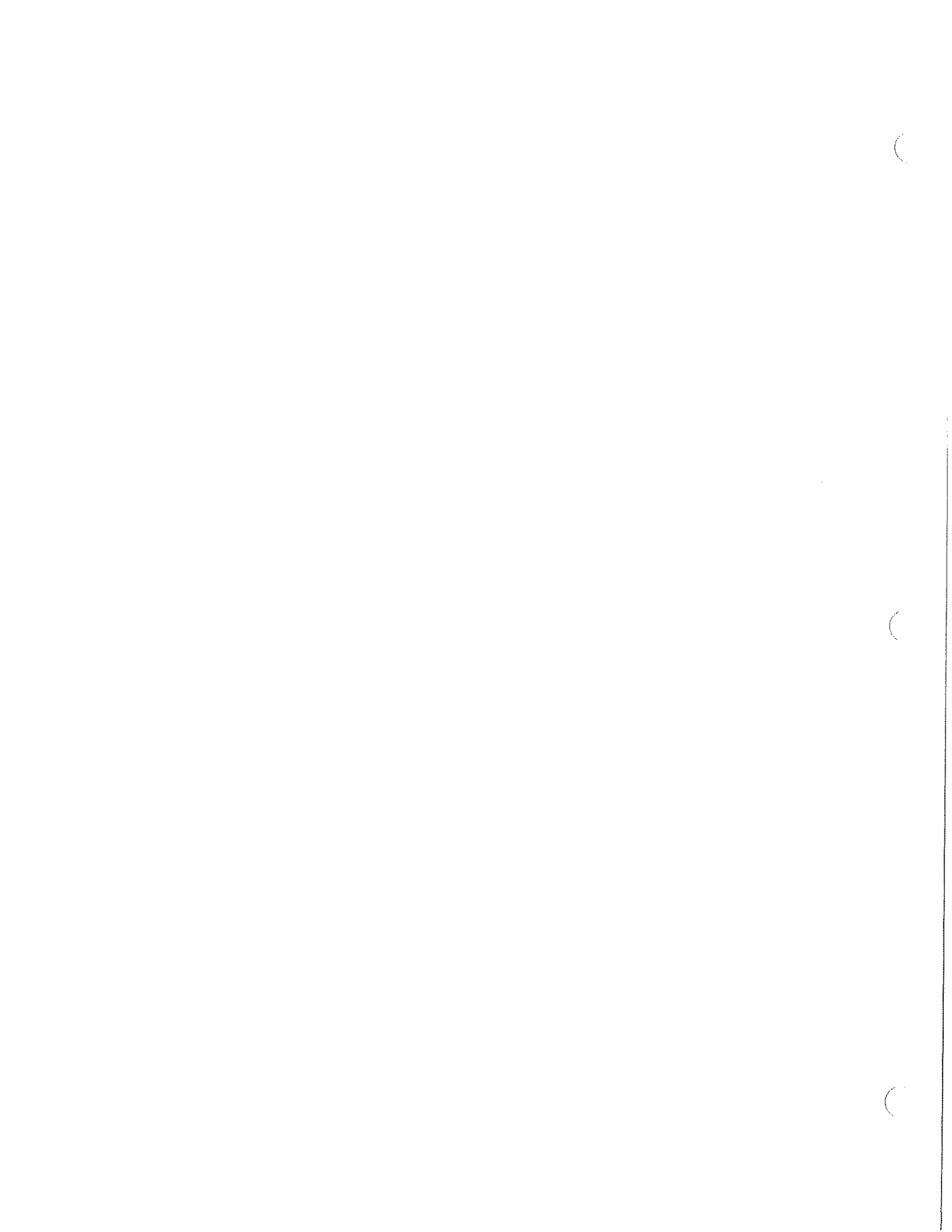

Figure 7.4 GCU-935 Right View



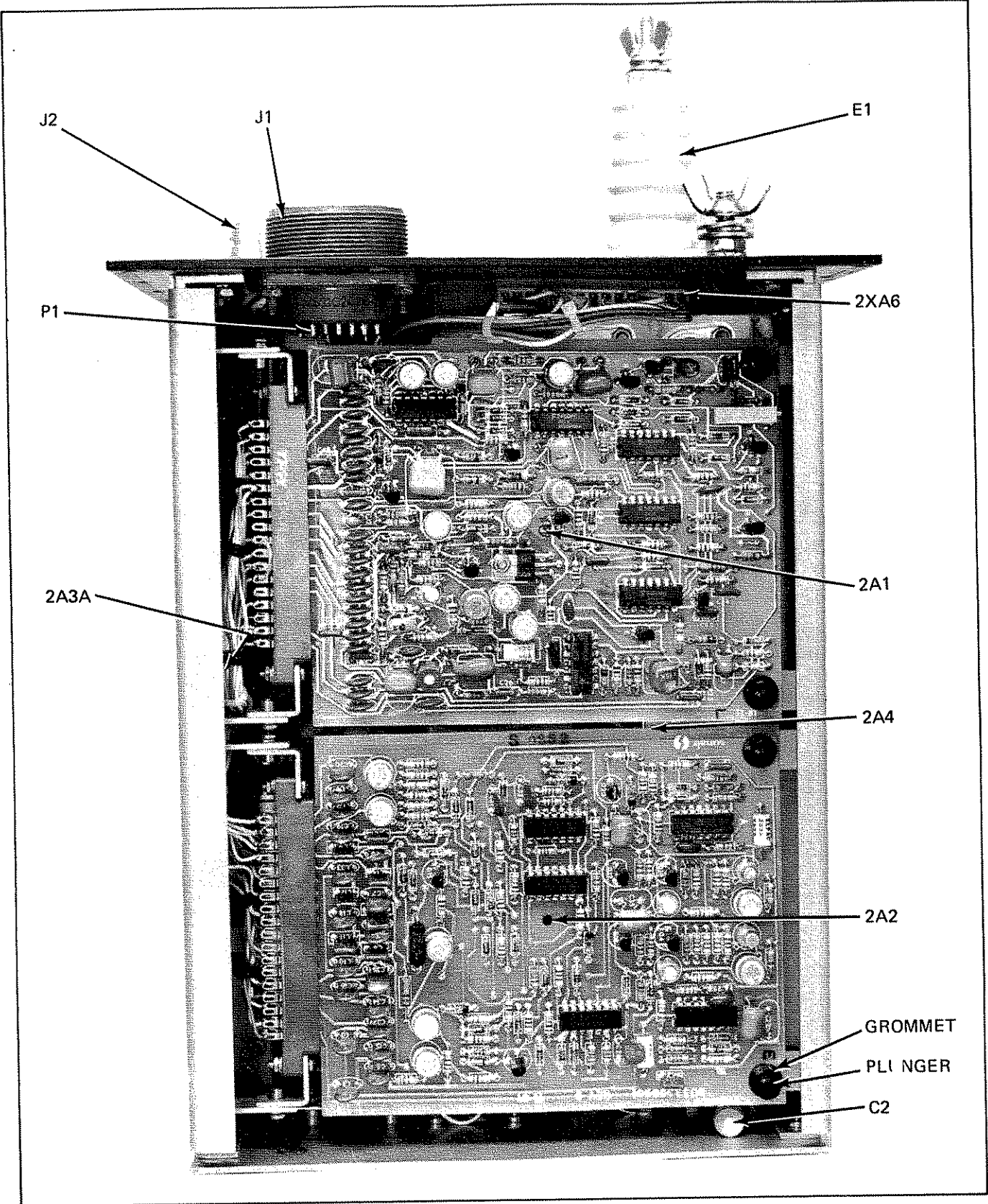

Figure 7.5 GCU-935 Bottom View

(

(

(

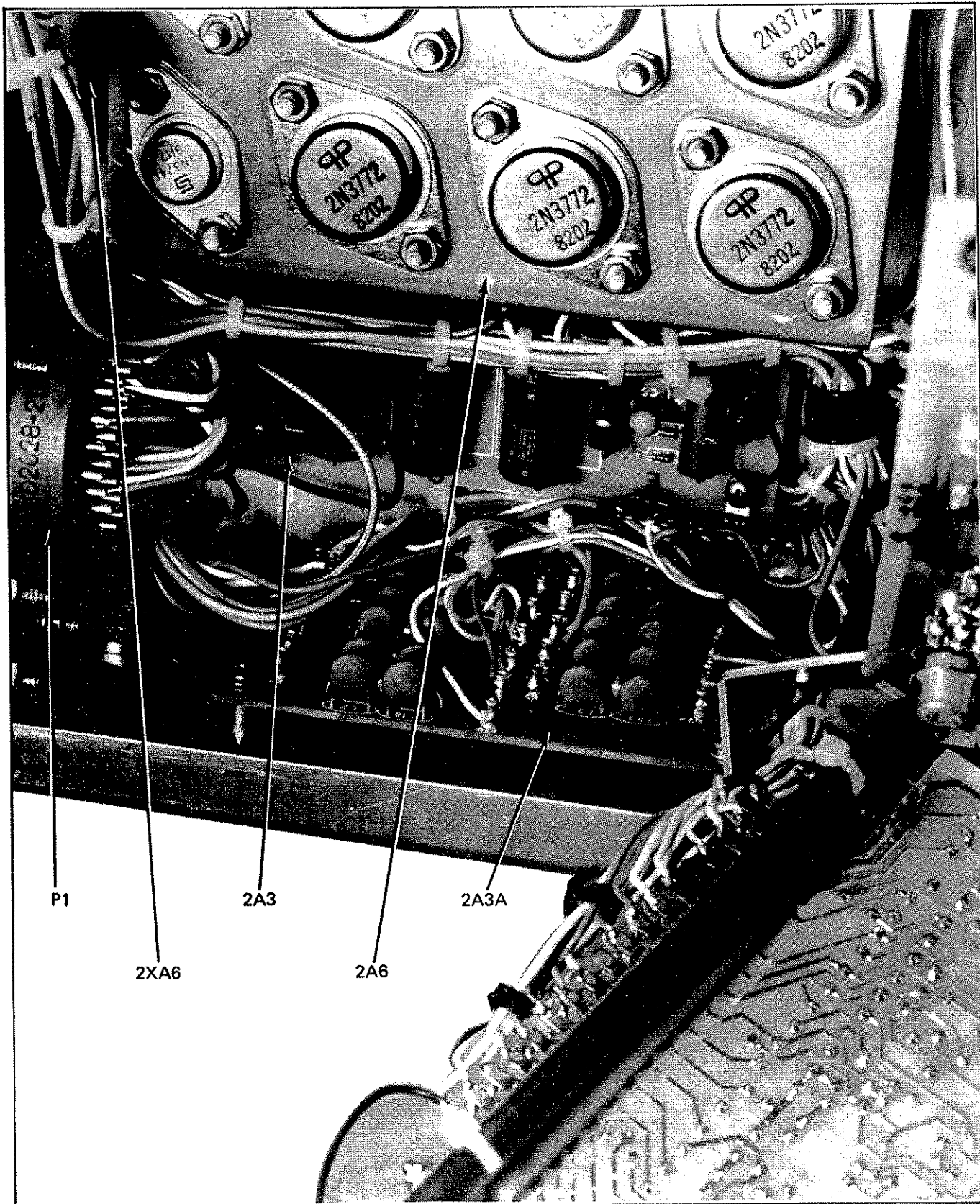

Figure 7.6 GCU-935 Bottom View, 2A1 Removed

(

(

(

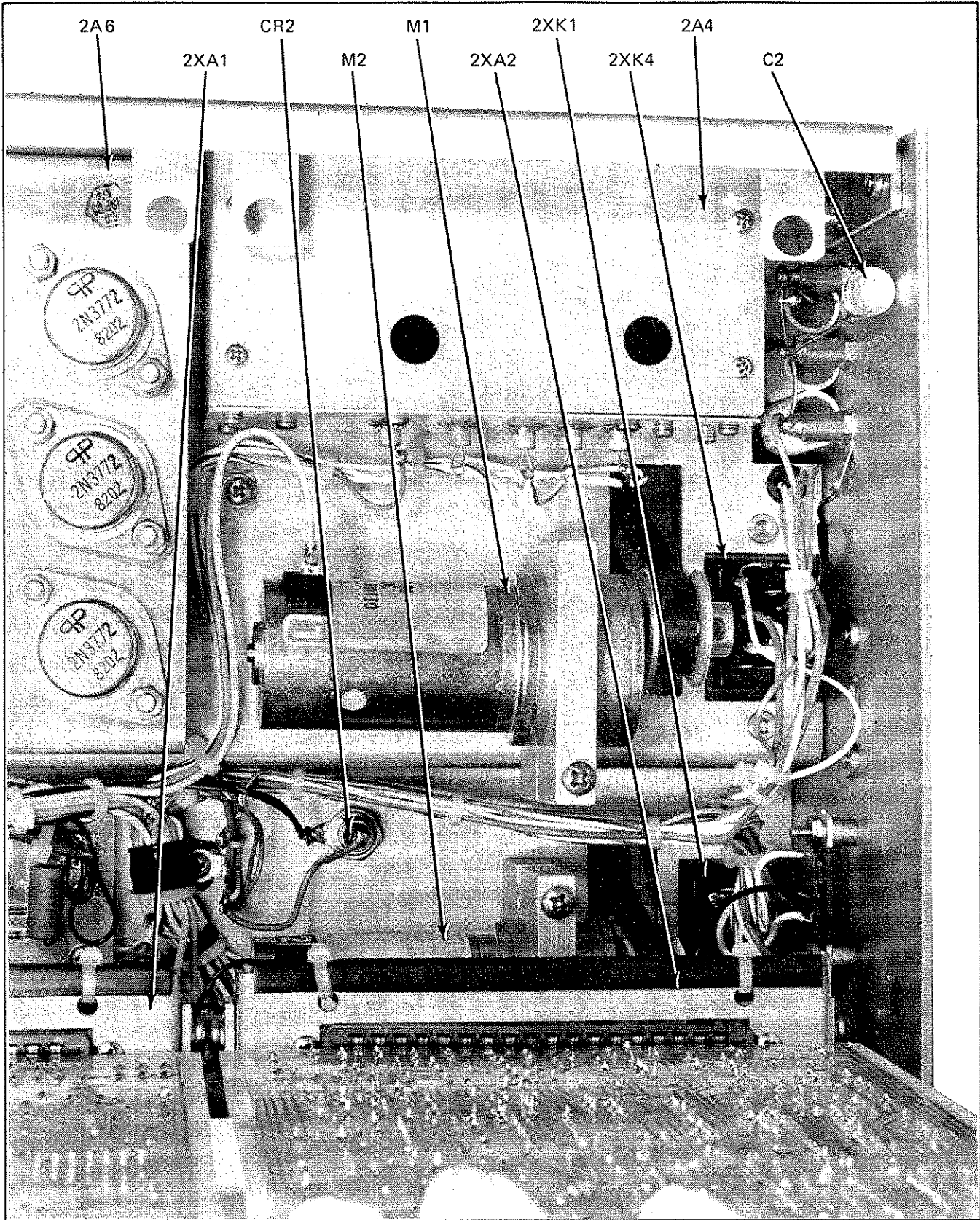

Figure 7.7 GCU-935 Bottom View, 2A2 Removed

(

(

(

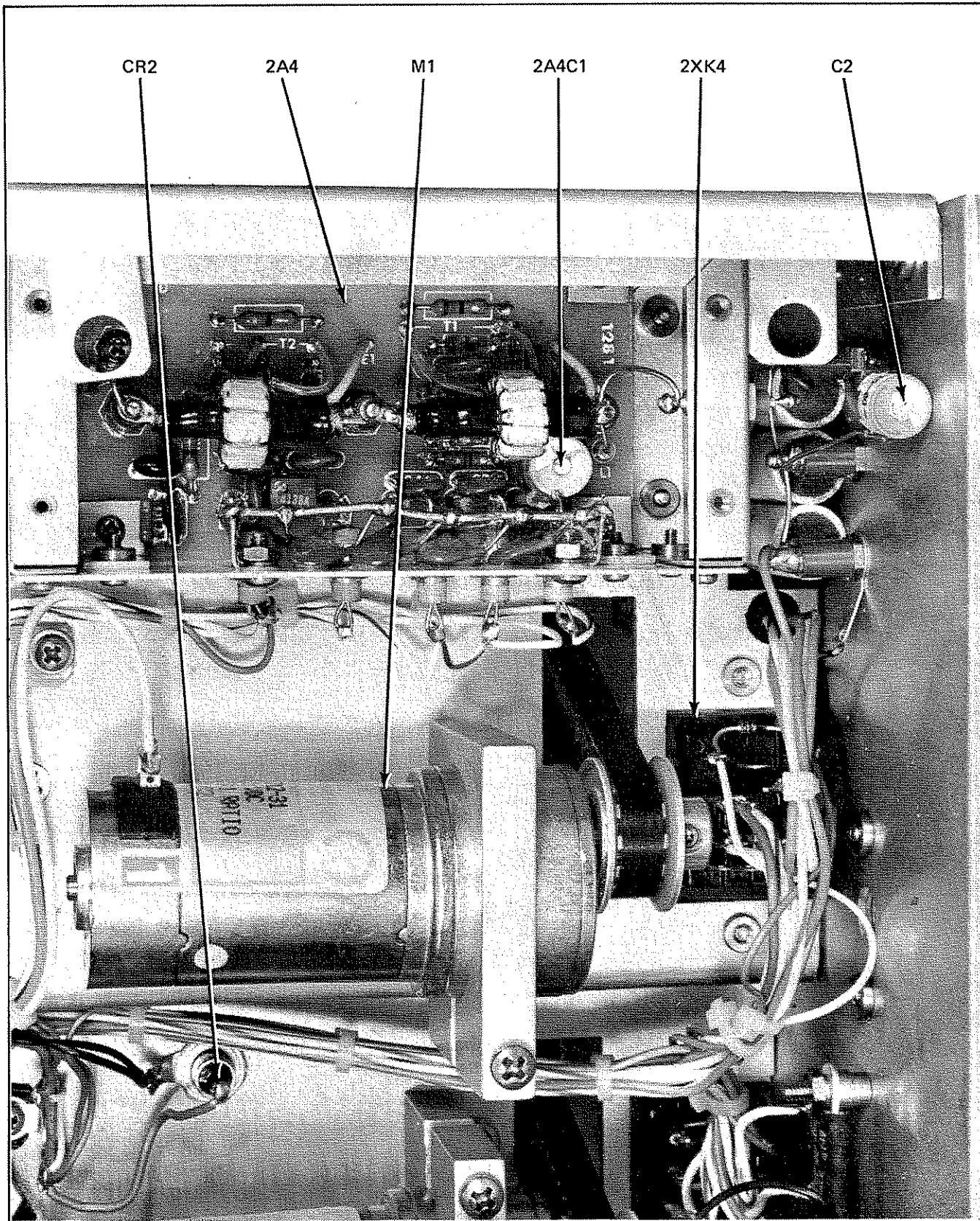
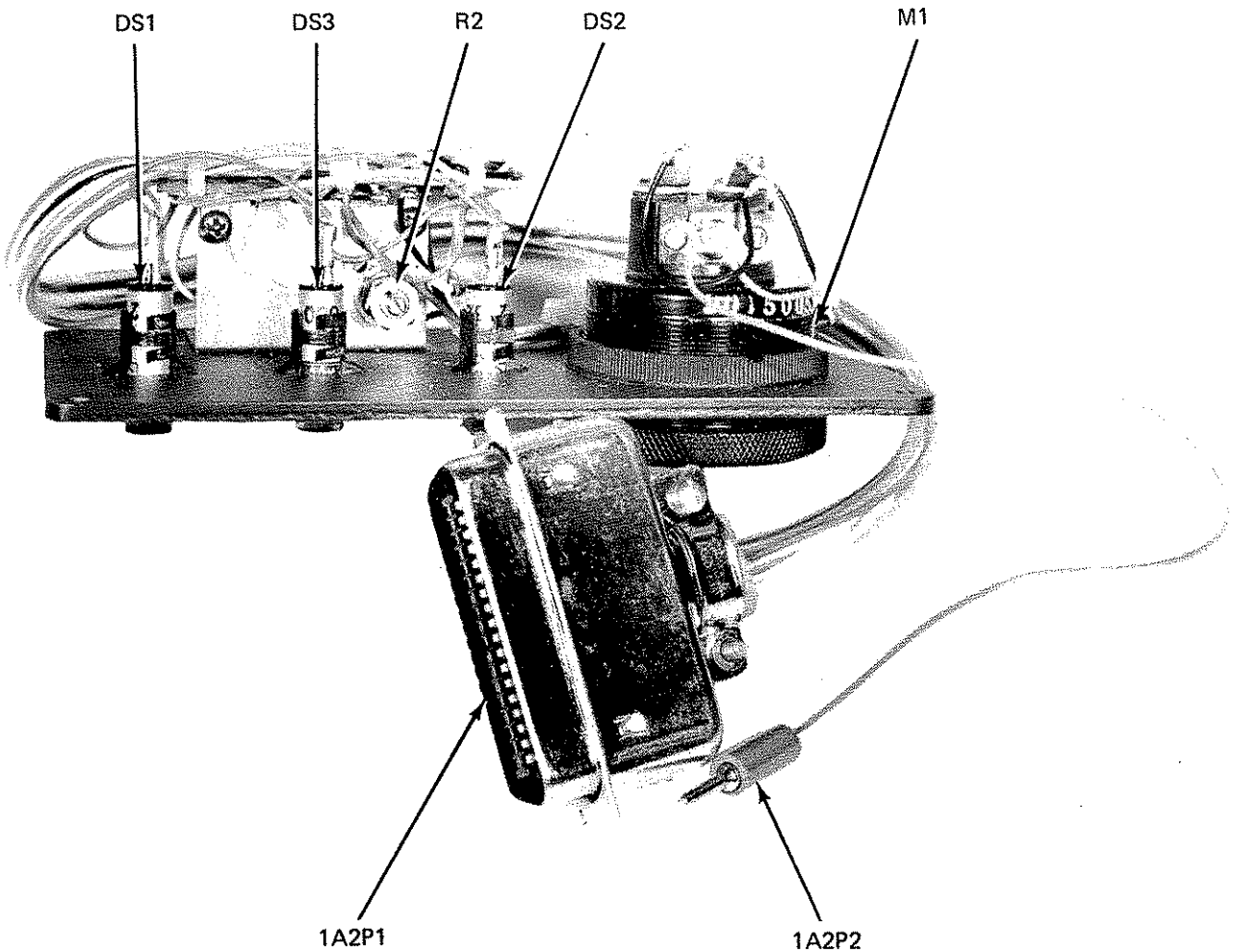

Figure 7.8 GCU-935, 2A4 W/O Cover

(

(

(



| DESIGNATOR | DESCRIPTION | SUNAIR PART NUMBER |
|------------|--------------------------------|--------------------|
| DS1 | Lamp Assy Green | 0841480001 |
| DS2 | Lamp Assy Red | 0841490007 |
| DS3 | Lamp Assy Amber | 0841500002 |
| M1 | Meter | 5024042204 |
| R2 | Pot. 10K, 10%, 3/4W, 1/8 Shaft | 0335900003 |
| 1A2P1 | Connector, Power, 36 Pin Rect. | 0754070000 |
| 1A2P2 | Plug, Phone Tip, Red | 0753680009 |

Figure 7.9 GCU-935 Control Panel

(

(

(

THIS PAGE INTENTIONALLY LEFT BLANK.

(

(

(



