

MODEL 1215 ANTENNA TUNER KIT

ASSEMBLY & OPERATIONAL MANUAL

Release "B" 6/28/11



TABLE OF CONTENTS

NOTE: This manual is divided into two sections, the “Reference Section” which covers the meter’s specifications and general information and the “Assembly Section” which covers the actual assembly and check-out of the kit. The “Assembly Section” is last since it will seldom be referenced after the wattmeter is built and tested for the first time. The “Reference Section” is essentially the owner’s manual for the completed unit.

- REFERENCE SECTION
 - Tuner Specifications
 - General Introduction
 - Circuit Overview
 - Schematic Drawing
 - Parts List / Bracket Drawings
 - Operating Tips
 - Troubleshooting Chart
 - Optional Balun for Balanced Feeders

- ASSEMBLY SECTION
 - Kit Assembly Suggestions
 - Required Tools & Supplies
 - Getting Started
 - Phase 1: Assembly of Rotary Inductor (L2)
 - Phase 2: SWR Bridge Circuit Board Assembly
 - Phase 3: Meter Switch & SWR Set Pot Assembly & Wiring
 - Phase 4: Antenna Switch Wiring
 - Phase 5: Chassis Assembly & Wiring
 - Phase 6: Wattmeter Calibration and Checkout

MODEL 1215 TUNER SPECIFICATIONS

CIRCUIT TYPE:	High Pass “T” Network
RF POWER RATING:	200 Watts maximum
FREQUENCY RANGE:	1.8 – 30 MHz
WATTMETER RANGES:	20 Watts, 200 Watts
OUTPUT MATCHING RANGE:	SWR up to 10:1
INPUT IMPEDANCE:	50Ω Resistive when tuner properly matched
CAPACITOR RATING:	10 - 210 pf @ 1000 Volts
INDUCTOR:	Toroidal rotary, 0.2 – 18 uH
DC POWER SOURCE:	12 – 16 Volts @ 150 ma (for meter illumination)
ENCLOSURE SIZE:	9.5”W x 4.2”H x 5.5”D (with knobs & connectors, the overall depth is approximately 7.25”)
WEIGHT:	3.5 lb (1.8 kg)

GENERAL INTRODUCTION

The Model 1215 is a full featured antenna tuner designed for the ham operator using transmitters or transceivers from QRP through 200 watts. A wide matching range combined with an integral wattmeter and SWR bridge provides all the necessary capabilities to ensure efficient operation with minimal RF losses due to impedance mismatches between the feedline and radio. Up to four antennas can be selected via a front panel switch. One of those antennas can be a single wire antenna and provision has been made to add an internal balun for connecting to balanced feedlines.

Our goal is to provide the builder with the satisfaction of “doing it yourself” and, in the process, furthering his or her understanding of the circuit operation. Understanding the circuit operation removes much of the “mystery” often encountered in adjusting an antenna tuner.

Follow the assembly instructions carefully and you will be rewarded with an antenna tuner with professional performance and appearance. Should you have any questions, Ten Tec Customer Service is available to help.

CIRCUIT OVERVIEW

1215 BLOCK DIAGRAM

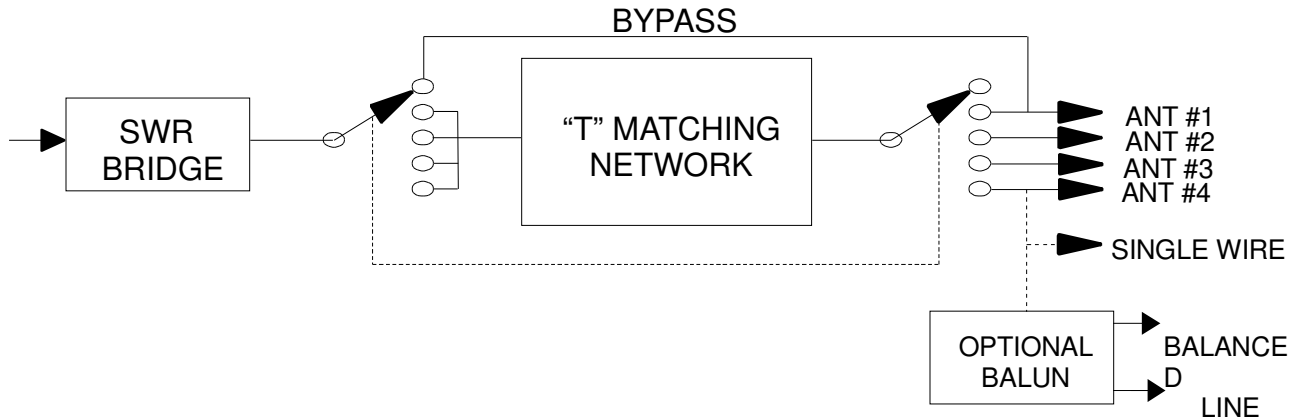

SWR BRIDGE

The internal SWR bridge is physically connected between the tuner input and the radio. The bridge performs three functions:

1. Measures transmitter output (forward) power
2. Measures the reflected power at the tuner input ("Radio") port
3. Displays the SWR on the built-in meter

The SWR measurement setting is used when adjusting the tuner for optimum performance. In this mode, the tuner is adjusted to produce, ideally, a 1:1 SWR as seen by the radio.

The bridge consists of an RF transformer, wound on a toroidal core, with the main transmission line passing through it. This allows sampling both the forward and reflected power levels present at that point. The outputs from the transformer are detected by two Schottky diodes, D1 and D2, and the DC voltage produced is used to drive the meter to display either the forward or reflected power. When the tuner properly matches the antenna system to 50Ω, the reflected power reading will be zero.

In the forward power measurement mode, a potentiometer is connected in series with the meter to display either 20 watts or 200 watts full scale. Once calibrated, the pots should need no further adjustments.

Since SWR is a measurement of the ratio of forward to reflected power, an "SWR Set" control is included on the front panel of the tuner. With the transmitter operating at its desired power level, the meter is placed in the SWR Set mode and the Set pot is adjusted for a full scale

reading. The switch can then be changed to the “SWR” setting and the value of SWR read directly. If the output power level is changed, the “Set” pot will need to be readjusted to maintain an accurate SWR reading.

ANTENNA SELECTION

The antenna tuner is equipped with a five position antenna selector switch. In the first position, BYPASS, the output of the SWR bridge is connected directly to Antenna Connector #1. This keeps the power and SWR measurement circuitry active, but bypasses the tuner circuitry. Note that the bypass position only functions for antenna #1.

In positions 2 through 5, the tuner is connected to antenna ports #1 to #4 in sequence. To connect a single wire antenna to the tuner, use the insulated terminal indicated on the rear panel. The antenna switch must be set to Antenna #4 for the single wire feed. To connect the tuner to an antenna with a balanced feed i.e., ladder line, a balun (balanced to unbalanced transformer) is required. The 1215 does not come equipped with a balun, however there are feed through posts on the rear panel which will allow a balun to be mounted internally and it's connections brought out through the rear panel. A jumper (supplied) between the “Single Wire” and “Balanced Feeder” post needs to be installed when a balun is being used. As with the single wire feed, the tuner must be set for Antenna #4 when using the balun. The “Balanced Feeder” jumper should be removed if Antenna #4 is being used for a coaxial or single wire antenna feed. Ten Tec offers an internal balun as an accessory for the 1215 tuner. The model number for that balun is 1216. As an alternative, information on building a balun can be found in the “Optional Balun” section of this manual or any recent edition of the ARRL Antenna Book. A web search with the keyword “4:1 balun” will provide many references for building a balun for tuner applications.

ANTENNA TUNER CIRCUITRY

The antenna tuner is a high pass “T” network with two series variable capacitors and a shunt variable inductor connected between them and ground. This configuration allows a wide range of impedances to be matched to the 50Ω output impedance of the radio. This configuration is fairly easy to tune if the proper procedure is followed. The tuning procedure is outlined in the “Operating Tips” section of the manual.

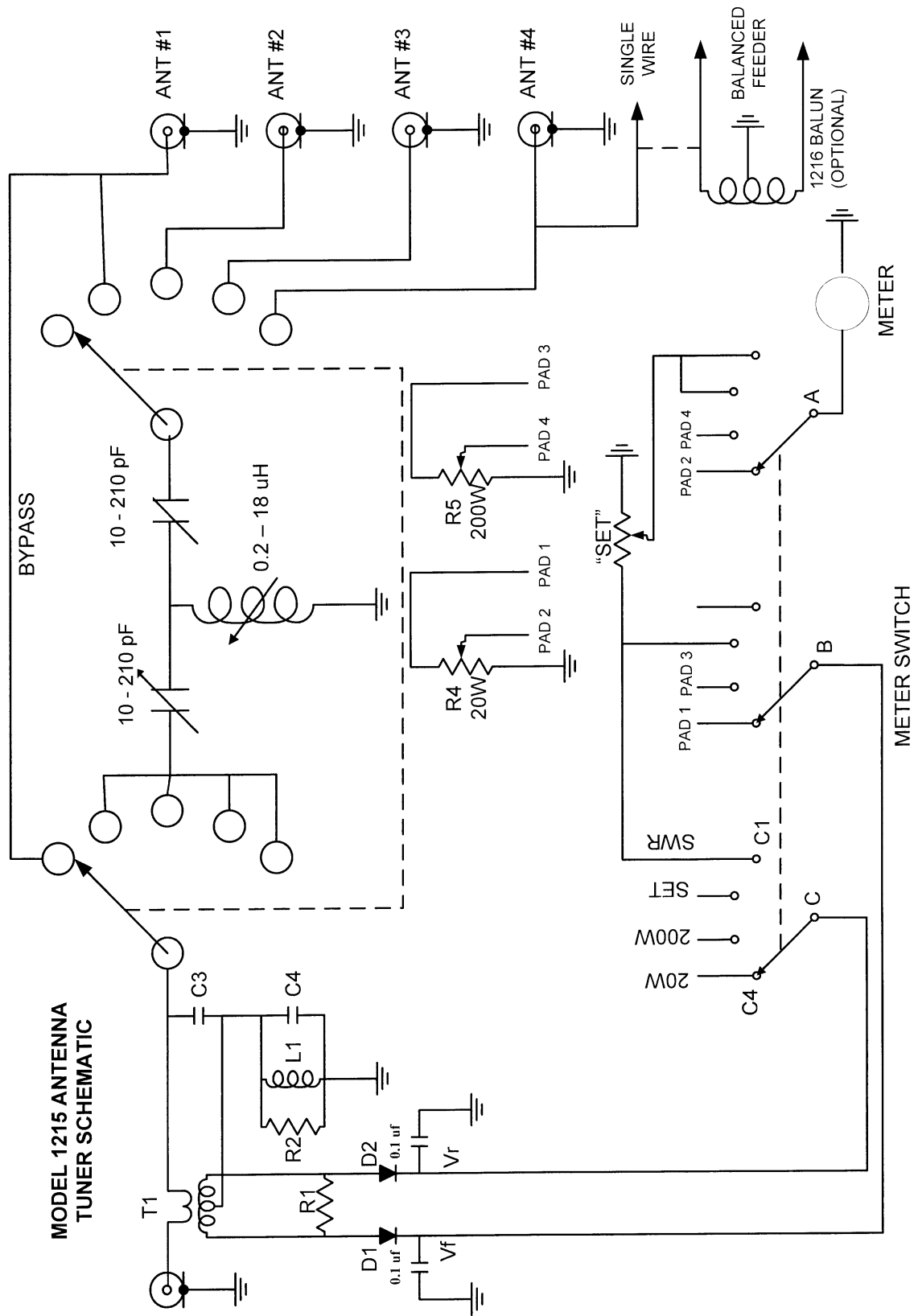

1215 ANTENNA TUNER PARTS LIST

PART #	DESCRIPTION	QTY
CHASSIS ASSEMBLY		
23227	Cap, Air Variable	2
27007	Lamp Socket, Bayonet	1
30894	10k Panel Mount Pot	1
32077	Rotary Switch ; 3 Pole / 4 Position	1
32098	Rotary Switch ; 2 Pole / 5 Position	1
34011	Pilot Lamp ; Bayonet Base	1
34043	Panel Meter	1
34070	Knob - "Meter Switch" & "SWR Set"	2
34071	Knob - "Antenna Switch" & "Inductance"	2
34072	Knob - "Transmit Match" & "Load Match"	2
35007	SO239 Coax Receptacle	4
35132	DC Power Jack ; 2.1mm	1
35402	DC Power Plug ; 2.1mm x 5.5mm	1
42010	Panel Bushing - "Ant Switch" & "Inductance"	2
46010	Wire, Hookup, #24 Black Stranded	24"
46011	Wire, Hookup, #24 Brown Stranded	15"
46012	Wire, Hookup, #24 Red Stranded	15"
46013	Wire, Hookup, #24 Orange Stranded	12"
46015	Wire, Hookup, #24 Green Stranded	15"
46016	Wire, Hookup, #24 Blue Stranded	12"
46018	Wire, Hookup, #24 Grey Stranded	24"
46019	Wire, Hookup, #24 White Stranded	24"
46057	Wire, Hookup, #24 White / Yellow Stranded	12"
46059	Wire, Hookup, #24 White / Blue Stranded	6"
90681	Nylon Feed-Thru Insulator	6
91217-6	Phenolic Shaft	1
91482	Shaft Coupler – 1/4"	1
93946	Flat Jumper for Rear Panel	1
80925 INDUCTOR SUB-ASSEMBLY		
38060	C Ring	1
77001	Copper Braid ; 3/16" Wide	4.8"
80924	Inductor Mount Bracket Assembly	1
21045	Toroid Core – Ferrite (large)	1
46076	#18 Solid, Silver Plated Wire	15 ft
90682	Toroid Bottom Cover	1
90683	Toroid Top Cover	1
90677	Rotor	1
90679	Hub	1
90690	Contact Stiffener	1
90691-1	Modified Contact	2
91369	Aluminum Inductor Shaft ; 1/4" Dia	1

PARTS LIST (CONTINUED)

PART #	DESCRIPTION	QTY
82062 SWR BRIDGE SUB-ASSEMBLY		
21003	Toroid Core – Ferrite (small)	1
21007	1mH Inductor	1
23261	Ceramic Capacitor – 0.1uF	2
23371	Ceramic Capacitor – 10pf / 1kv	1
23400	Ceramic Capacitor – 470 pf / 100V	1
28071	Schottky Diode – BAT41	2
30082	68Ω 2W Resistor (blue-gray-black)	1
30136	680Ω 1/4W Resistor (blue-gray-brown)	1
30806	1K Variable Resistor (Pot)	2
35007	SO239 Coax Receptacle	1
46022	Wire, Solid #28 Red	18"
46070	Wire, Solid #28 Green	18"
82080	PC Board Assembly	1
MECHANICAL PARTS		
41011	#10 Solder Lug	4
41039	#4 Solder Lug ; internal tooth	3
42003	Rubber Mount Foot	4
51002	#4 Lockwasher	15
51007	#10 Flat Washer ; 7/16" OD	11
51011	Fiber Shoulder Washer ; 5/8"	4
51034	#10 Lockwasher	4
51039	3/8" Flat Washer	4
54002	4-40 Hex Nut	15
54003	3/8"x32 Hex Nut	4
54005	10-32 Hex Nut	4
54016	Self-Threading Nut	1
54017	10-32 Wing Nut	4
54029	2-56 Hex Nut	4
54048	Metric M9 x 0.75mm Nut	1
60001	4-40 x 1/4" Screw	2
60003	4-40 x 3/8" Screw	7
60035	10-32 x 3/4" Screw	1
60036	10-32 x 1-1/4" Screw	3
60067	2-56 x 1/4" Screw	4
60069	4-40 x 3/8" Screw w/captive lockwasher	10
60080	4-40 x 3-16" Flat Head Screw	8
60092	Screw, 6-32 x 3/16", Black	2
65009	#4 x 1/4" Pan Head Screw	2
93954-CN2A	Chassis	1
93955	Cover	1
93956	Meter Support Bracket	1
93957	Antenna Switch Bracket	1



MECHANICAL PARTS IDENTIFICATION

OPERATING TIPS

Operation of the tuner is fairly straight forward. The most difficult portion is usually the “first tuning” for a given band or antenna. The following procedure will greatly simplify this first tuning, as well as all subsequent tuning:

1. Set the “Transmitter” and “Load” capacitors and the “Inductance” to maximum.
2. Set the “Meter” switch to “SWR SET” and adjust the SWR pot fully counter-clockwise
3. Place the transmitter on frequency and reduce the power as far as possible
4. Key the transmitter and adjust the SWR pot for a full scale reading (increase the transmitter power slightly if a full scale reading can not be obtained.
5. Set the “Meter” switch to “SWR” and adjust the inductor for a minimum reading
6. Adjust the “Transmitter” and “Load” capacitors for a minimum SWR reading
7. If the SWR can not be reduced to 1:1, adjust the inductor switch one position higher or lower.
8. Adjust the “Transmitter” and “Load” capacitors for a minimum SWR reading
9. If the SWR is higher than the original value, adjust the inductor switch two positions in the opposite direction and repeat the capacitor adjustments.

Using this procedure, the minimum SWR should be obtained relatively quickly. Note that some loads may not be capable of being matched to a 1:1 SWR. In such cases, leave the tuner set for the lowest SWR achievable. An SWR of 2:1 or less is generally acceptable to most transmitters and does not result in any appreciable loss in strength of the radiated signal.

Recording the inductor and capacitor settings for several frequencies across the desired bands will allow a quick pre-setting of the tuner later on.

Although the tuner is rated to operate at a 200 watt level, it should not be tuned at this level, other than for minor adjustments of the capacitors. Do not switch the inductor while keyed at power levels greater than about 25 watts. Always pre-tune the tuner at the lowest possible power level.

If the tuner is to be used with a single wire feed antenna, connect the feed wire to the “Single Wire” terminal on the rear panel. The antenna selector switch must then be set to “Antenna 4”. Note that, if a single wire feed is being used, there must not be another antenna connected to the “Antenna 4” SO-239 connector.

If a balanced feeder is to be used, connect the supplied jumper bar between the “Single Wire” terminal and one of the “Balanced Line” terminals on the rear panel of the cabinet. The balanced feeder is then connected to the two Balanced Feeder terminals. **NOTE:** *Using a balanced feeder requires that a balun be installed!* The balun can be enclosed inside the tuner cabinet and connected to the provided Balanced Line terminals. See the “Optional Balun” section of this manual for further information. As with the single wire feed, there must not be any other antenna connected to the “Antenna 4” SO-239 connector when using a balanced line fed antenna.

A final point to remember whenever using an antenna tuner is that the “antenna” itself is not being tuned. The tuner simply transforms the impedance seen at the radio end of the feedline to 50 Ohms. Any mismatch between the antenna itself and the feedline will remain unaffected. That mismatch can only be corrected by installing a matching device directly at the antenna feedpoint. In most cases, the mismatch between the antenna and feedline is not the limiting issue. A detailed discussion of this can be found in the ARRL Antenna Book or other ham publications.

TROUBLESHOOTING CHART

If any difficulties are encountered with the 1215 Tuner, check the following items first:

- Verify that the radio is connected to the “Radio” connector on the rear panel.
- Verify that the Antenna Switch is in the correct position for the antenna being used.

Once the above have been verified, use the following chart if problems still exist:

PROBLEM SYMPTOM	CHECK THE FOLLOWING:
High SWR can not be reduced	No antenna connected, or wrong antenna selected ; SWR “Set” control set too high ; Tuner in “Bypass”
SWR Meter not functioning properly	Check SWR in “Bypass” mode ; Check SWR with a 50Ω load and tuner in “Bypass”; Verify setting of SWR “Set” control; Verify radio connected to “Radio” port
Power Meter not functioning	Check operation with tuner in “Bypass” and a 50Ω load connected to “Ant 1” port. ; Verify that radio is connected to “Radio” port.
Tuning capacitors and / or inductor have no effect	Verify that tuner is not in “Bypass” ; Confirm that an antenna is connected and selected.
Incorrect Power Readings	Check readings with a 50Ω load on “Ant 1” and put tuner in “Bypass” ; If SWR function is working normally, check power calibration.
Arcing inside cabinet	Verify that power level is not in excess of 200 watts ; Check that inductor contact is not “between” two stops. Check that ground braid from inductor shaft does not contact TX and Load capacitors.
No meter backlight	Verify that 12 – 16 VDC is applied to DC input connector. Positive to the center pin and negative (ground) to the connector shell. Verify that bulb is not burned out.
Room is “hot” with RF	Verify that tuner ground lug is connected to station ground along with the radio. Station ground should be common to all equipment and be tied to an external ground rod. If a single wire, or balanced feeder, is used, try re-routing them away from any of the equipment.

If your radio is equipped with an internal SWR / Power meter, it is not unusual for a small difference to be noted between the SWR shown on the tuner meter and the SWR shown on the radio's meter. There will be some minor variances due to the differences between the SWR bridge in the radio and the bridge used in the tuner, however the major contributor is generally the cable length between the radio and the tuner. That can be verified by connecting a shorter or longer cable and noting if the difference in readings changes. In a perfectly matched system, the interconnecting cable length becomes irrelevant. For less than a perfect match, the measured SWR will vary depending on where along the cable the measurement is made. In this case, the tuner's SWR meter and the radio's SWR meter are located at different points on the cable and a reading difference is expected. Note that the difference in readings will vary with frequency. The lower the frequency, the less difference is generally seen. Since the radio's SWR meter is measuring the SWR at the radio, rather than at the input to the tuner, adjust the tuner for minimum SWR as displayed on the radio's SWR meter.

This assumes that there is no equipment connected between the radio and the tuner i.e., an external low pass filter or other device. If there is something in between, temporarily connect the radio directly to the tuner and re-check the readings. If they begin to correlate, the intermediate device may have a problem or may simply be affecting the match between the tuner and the radio. If the device is functioning normally, verify that the cables used are good and, if so, use the SWR meter on the radio when adjusting the tuner.

OPTIONAL BALUN FOR USE WITH OPEN WIRE (LADDER LINE) FEEDERS

The 1215 tuner is capable of connecting directly to open wire feeders if a 4:1 balun is installed. The necessary insulated feed-thru terminals are provided on the rear of the cabinet which allows for a balun to be installed inside the unit.

A 4:1 balun is a relatively simple device which can be built or purchased at fairly low cost. Ten Tec offers one, Model # 1216, as an accessory for the 1215 tuner. For further information, check the Ten Tec web page (www.tentec.com) or call our sales department at (800) 833-7373. For more information about baluns, a web search using the key words "4:1 balun" will produce a long list of references.

The purpose of the balun is to convert the unbalanced output of the tuner to a balanced output which will feed the open wire (ladder line) feeders used on several types of broadband or multi-band antennas.

A balun can be built using a T200A-2 core with 13 bifilar turns of #16 Teflon coated wire, connected as shown in Figure 1. Alternately, a T-200-2 core with 17 turns of #16 Teflon coated wire can be used. Power handling capability is about 300 watts.

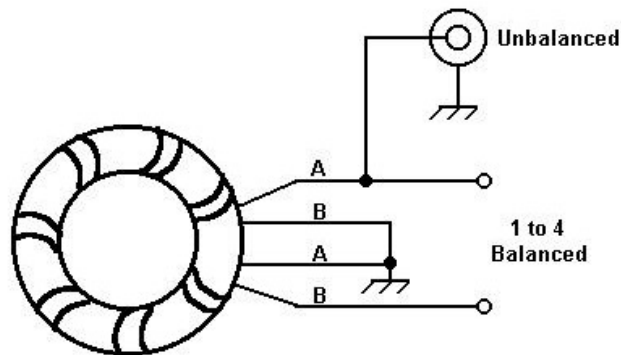

Figure 1

KIT ASSEMBLY

This section of the manual covers assembly of the Model 1215 Tuner. Assembly is done in a number of “phases” designed to make assembly easier while allowing a number of “break” points. The assembly phases are:

- Phase I: Rotary Inductor Assembly
- Phase II: SWR Bridge Circuit Board Assembly
- Phase III: Meter Switch & SWR Set Pot Assembly & Wiring
- Phase IV: Antenna Switch Wiring
- Phase V: Chassis Assembly & Wiring
- Phase VI: Wattmeter Calibration & Checkout

NOTE: This manual is available in pdf format at www.tentec.com. The pdf format allows you to enlarge any of the drawings / photos in the event that there are any questions of what goes where and how it is mounted and / or connected.

REQUIRED TOOLS / MATERIALS:

Tools / materials required for kit assembly include:

- Needle nose pliers
- Small pair of wire cutters
- Soldering iron (25 – 50W)
- 1/2” nut driver or socket
- Digital voltmeter (optional, for calibration)
- Philips head screwdriver
- Small flat (dial) screwdriver
- 60 / 40 (or 63 / 37) rosin core electronics solder
- Epoxy glue

Recommended tools include:

- Small bench vise
- Solder removal braid
- Sharp utility knife
- Ruler
- Work gloves (for pulling wire)

PHASE 1: ROTARY INDUCTOR ASSEMBLY

Kit Assembly Note: *In this section, as in all the others, two check boxes are provided at each step of the assembly. Check off each step as it is completed. Should you need to go back to re-check your work, use the second check-off box as each previously completed step is verified.*

OVERVIEW

This sub assembly kit is packed separately for your convenience. Before working with the Inductor parts kit, please read all of the assembly instructions first. Examine the various parts and visualize how they fit together. Notice how the grooves in the toroid covers are designed to assure uniform winding. We recommend building this coil assembly first because it is necessary to secure the hub to the toroid with an epoxy glue after winding. Other phases of the kit assembly can be completed while the coil assembly dries.

COIL WINDING PROCEDURE

The most important, and most difficult, part of winding the toroid is to make a good start. After the first few turns, it will become progressively easier to wind.

While the grooves in the toroid covers provide uniform spacing, the winding must be kept tight to prevent adjacent turns from shorting together. Treat each turn as having four components: top, two sides and the inner side. Keep each side as tight as possible. Doing so will result in smooth operation of the completed assembly. The "top" (outside) layer makes contact with the rotor and consequently needs the turns to be as equally spaced and flat (tight) as possible.

To prevent scarring of the silver plated wire, wrap protective tape around each jaw of any pliers used in the winding process. Alternately, rubber tubing can be slipped over the pliers jaws.

The wire will be routed through the center of the toroid many times during the winding process. Avoid kinking the wire as it is passed through.

If a bench vise is used to hold the toroid assembly firmly, cushion the bare vise jaws with wood shims or plastic strips to prevent damage to the nylon toroid shells.

The following directions presume winding the toroid from one end to the other. Some builders may prefer to start in the middle and work toward each of the two ends. If you elect to start in the center, be sure to follow the groove patterns exactly and start with the middle of the silver plated wire at the midpoint of the toroid.

1. Place the toroid core within the two nylon shells. While not necessary, it is OK to use some glue sparingly to keep everything together (hot glue is ideal for this). Epoxy glue is required only to secure the hub after winding.
2. While most turns require pulling the full wire length through the center, you can get started by looping 3 – 5 loose turns, leaving a “pigtail” lead of 6” to 12”.
3. Lock the pigtail wire around the bottom retainer slot (see photo and drawing), then use padded pliers to tighten the first several windings in place per the details emphasized in the beginning of the coil winding procedure above.

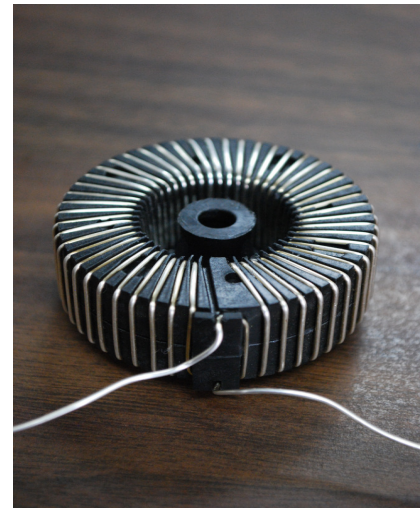
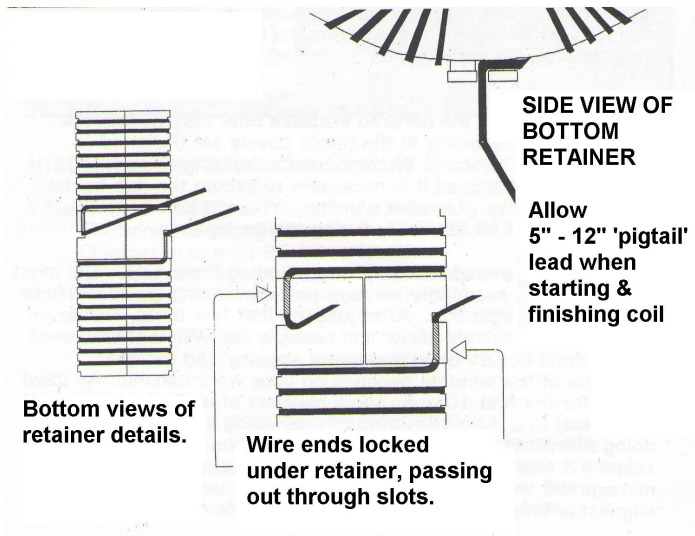

4. Loop the full length of wire back through the center and form the next turn tightly. Be careful not to kink the wire.
5. Repeat the preceding steps until all turns are made. It does get easier as the wire gets shorter!
6. After tightening the final turn, wrap the remaining wire through the other retainer slot and cut the excess wire to leave another “pigtail” lead of 6” to 12”.
7. Slip the hub into one side of the toroid and visualize the assembly before gluing: the retainer slots are at the bottom, with the two hub holes aligned horizontally. See photo on the top of the next page for reference.

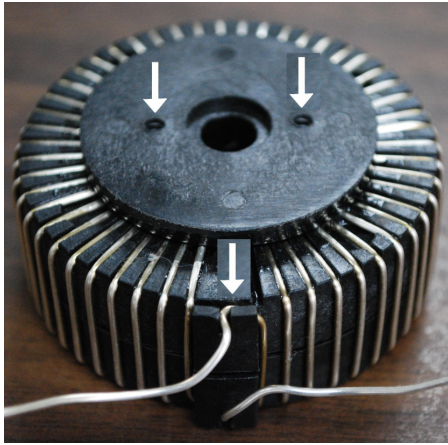

8. Follow the glue manufacturer's directions and mix enough epoxy glue to thoroughly coat the portion of the hub to be in contact with the toroid.
9. Glue the hub to the toroid, aligning the hub per step 7. Set the glued assembly aside with some weight on top or clamp the assembly together.
10. Organize the following for assembly: rotor bracket, contact strips (2), contact stiffener and two each #2-56 screws and nuts.
11. Assemble the rotor in this order: #2-56 screws, stiffener strip, two contact strips, bracket and #2-56 hex nuts. (**See photo and drawing below** – note that the photo unit has rivets in place of the screws and nuts you will be using)
 1. Align the holes of the rotor bracket with the contact strip holes
 2. Align the stiffener on the contact strips
 3. Insert screws through the stiffener, contact strips and rotor bracket (in that order)
 4. Attach the nuts
 5. Tighten securely
 6. With a pair of needle nose pliers, grasp the stiffener & contact strips just past the edge of the rotor bracket and bend them slightly as shown below. This will increase the contact pressure of the contacts to the inductor wire.

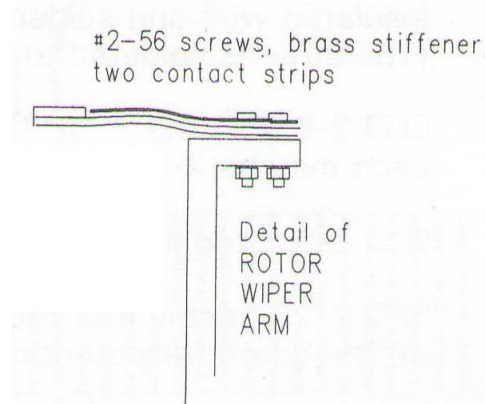

12. Using a 7/16" nut driver, thread the 1/4" thread cutting fastener on the rear of the shaft, the end with internal threads for mounting mounting the wiper arm. Thread it onto the shaft about 3/8" and then back it out until there is just enough room to slip the rotor onto the end of the shaft (see above). It will be necessary to use a small vise or Vise-Grips to hold the rod while the fastener is being threaded on.
13. Mount the rotor to the 1/4" shaft with one #4-40 1/4" screw and one #4 lock washer. Tighten securely.
14. No further work should be done with this inductor assembly until the epoxy is set per the manufacturers directions. Proceed now to Phase II of this project (SWR Bridge Circuit Board Assembly). Return when the epoxy bond from the hub to toroid has set.

AFTER THE EPOXY IS SET:

1. Mount the hub / toroid to the aluminum bracket (with the pressed in brass bushing) using the two #4, 1/4" self tapping screws through the bracket and into the hub. Do not fully tighten the screws at this time. The bracket faces away from the toroid, toward the front panel of the tuner. (See drawing)

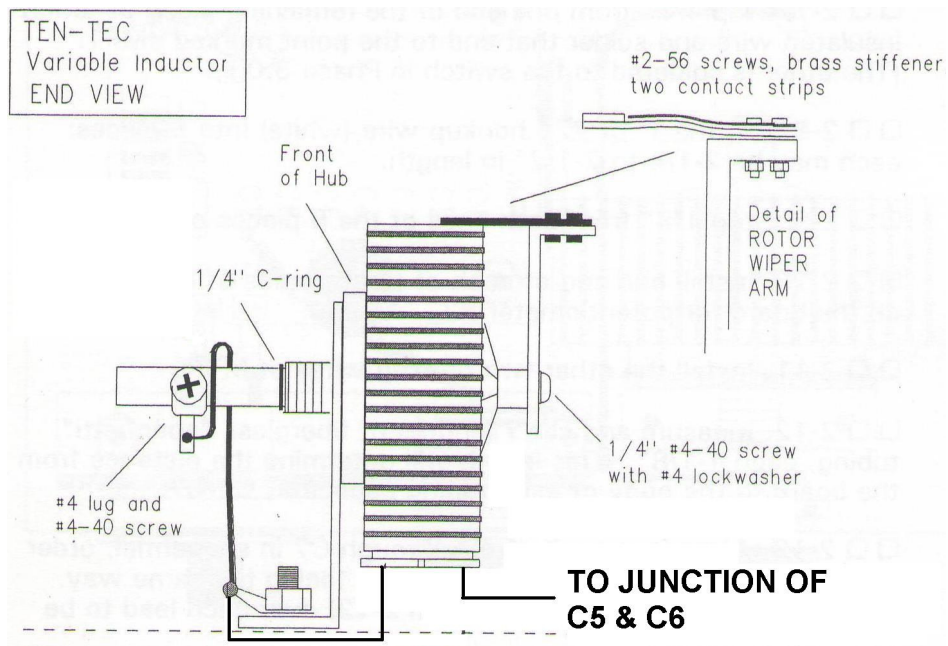

2. From the rear of the toroid / hub, slide the front end of the rotor shaft / wiper assembly through the hub until stopped by the thread cutting fastener.

3. Slide the “C” ring over the front end of the rotor shaft and slide it downward until it snaps into the groove just in front of the brass bushing. Tighten the thread cutting fastener as needed to minimize slippage of the shaft in the hub without making the shaft difficult to turn. Note that it may be easier to adjust the thread cutting fastener by temporarily removing the wiper assembly and using a nut driver. Correct positioning of the fastener is where it almost touches the wiper bracket. (Refer to photo on Page 18) Now tighten the two screws fastening the hub to the bracket.

4. Install the #4 solder lug and #4-40 x 3/8” screw in the threaded hole near the front of the shaft. (Refer to the drawing on the previous page)

5. Solder one end of the braid to the solder lug mounted on the shaft.

6. Adjust, if necessary, the rear, thread cutting, tension fastener and the front “C” ring to assure good contact to the windings by the contact arm with minimum sliding of the shaft in the hub.

7. Set the assembly aside.

PHASE II: SWR BRIDGE CIRCUIT BOARD ASSEMBLY

OVERVIEW

The SWR Bridge Circuit Board Assembly consists of the bare circuit board, Part # 78366, the input antenna connector, a toroidal RF transformer and assorted passive components. The “component side” of the board is the side with the silk screened outlines of each of the components along with their component designators. All parts, with the exception of the input connector and associated standoffs, will mount on the component side of the board.

When mounting the electronic components (resistors, inductors, diodes and capacitors), insert their leads through the indicated solder pads and pull them snugly down to the board. On the solder side, bend the leads slightly where they emerge from the board to hold the components in place for soldering. The leads will be cut off after soldering. The two potentiometers will “snap” into position when inserted into the board. The resistors, capacitors and inductors can be installed in either direction. The diodes must be installed with their banded end corresponding to the banded end screened onto the board. For these passive components, the component value, followed by it's marking, is shown within the parentheses. Instructions for winding and installing the small toroid RF transformer will discuss proper orientation of the device when mounting it on the circuit board.

CIRCUIT BOARD ASSEMBLY

Refer to Figure 2 in the Appendix for the following steps:

1. Install resistors R1 (68 Ω , 2 Watt, Blue-Gray-Black) and R2 (680 Ω , 1/4Watt, Blue-Gray-Brown) onto the circuit board.
2. Solder each of the resistor leads and clip off the excess.
3. Install inductor L1 (1 mH, Brown-Black-Red), capacitors C1 (0.1 uf, "104"), C2 (0.1 uf, "104"), C3 (10 pf, "10k") and C4 (470 pf, "471") onto the circuit board.
4. Solder each of the leads and clip off the excess.
5. Paying attention to the banded ends, install diodes D1 ("BAT 41") and D2 ("BAT 41") onto the circuit board with the banded ends as shown on the board.
6. Solder each of the leads and clip off the excess.
7. Insert the two potentiometers, R4 (1k Ω) & R5 (1k Ω), into the circuit board. Their terminals will "snap" into place when properly seated.
8. Solder each of the three terminals on each potentiometer to the board. There is no need to clip any of these leads after soldering.
9. Mount the SO-239 RF connector onto the two standoffs on the solder side of the circuit board using two 4-40x3/8" screws with attached captive split washers. The center pin of the connector should protrude slightly though the solder pad on the board.
10. Solder the center pin to the circuit board. Ensure that the pad is completely filled with solder with no visible gaps.
11. Perform an inspection on the board to ensure that all components are in their correct location and that all leads are soldered and clipped as necessary. Temporarily set the circuit board assembly aside.

RF TRANSFORMER ASSEMBLY

The RF transformer is used to sample the forward and reflected power levels so that they can be displayed on the front panel meter. The main winding is known as “bifilar” and consists of two twisted parallel wires wound on the core, as compared to “conventional” transformers which have “single wire” secondary windings. The primary side of this transformer will consist of a single loop of wire passing through the center of the coil.

The first step is to prepare the main winding.

1. Take the piece of Red colored #28 varnished wire (Part #46022) and the piece of Green colored #28 varnished wire (Part # 46070) and hold them parallel to each other.
2. Twist one end of each together and clamp them with a small vise or anything which will hold them in position.
3. Pull the two wires horizontally toward you (hold them 4” - 6” apart) and begin twisting them together by turning the free ends together. Twist them until you see about 3 – 4 twists per inch.
4. Remove from the vise and separate the two ends which were originally twisted together.
5. Using the *bifilar* wire you have just twisted, wind 12 turns on the core, as follows. The *start*, *bottom*, and *clockwise* directions for these windings are key to getting the phasing correct in this directional coupler. *START* by leading the twisted wire through the center of the core from the *bottom*. Pull the wire through until about 1-1/2 inches of the two *START* wires remains outside the core. See Figure 3 (next page) for reference.
6. Continue winding around the core in a *clockwise* direction. Count each time the wire pair goes through the center hole as a turn. Space the turns to take up most of the core, as Figure 3 shows. The *FINISH* end will emerge from the center hole.
7. Form a center-tap for the transformer by twisting together “Red *Finish*” to “Green *Start*”. Be sure to scrape of the colored varnish first! When scraped, the wire will have a shiny copper appearance. Refer again to Figure 3. Before proceeding, check out this wiring with your ohmmeter or continuity checker as follows. “Red *Start*” must have continuity to “Green *Finish*” *AND ALSO* to the center-tap. After assuring that your connection is correct, solder the center-tap wires together.
8. Mount the toroid on the circuit board, over the standoff post, and solder the three leads to the pads as shown in Figure 2 (In Appendix).

9. As shown in Figure 2, solder a piece of white wire to the plated through hole coming from the SO-239 connector (RF Input) and route it down through the standoff in the center of the toroid.
10. Route the wire on the solder side of the board up through the plated through hole next to the “RF Out” pad and solder it to the board (the pad is shown by a white arrow in Figure 2). Clip off any excess at both ends of the wire.
11. Check over all connections on the circuit board to make sure that all are soldered and excess lead lengths have been clipped off. Set the board aside for now.

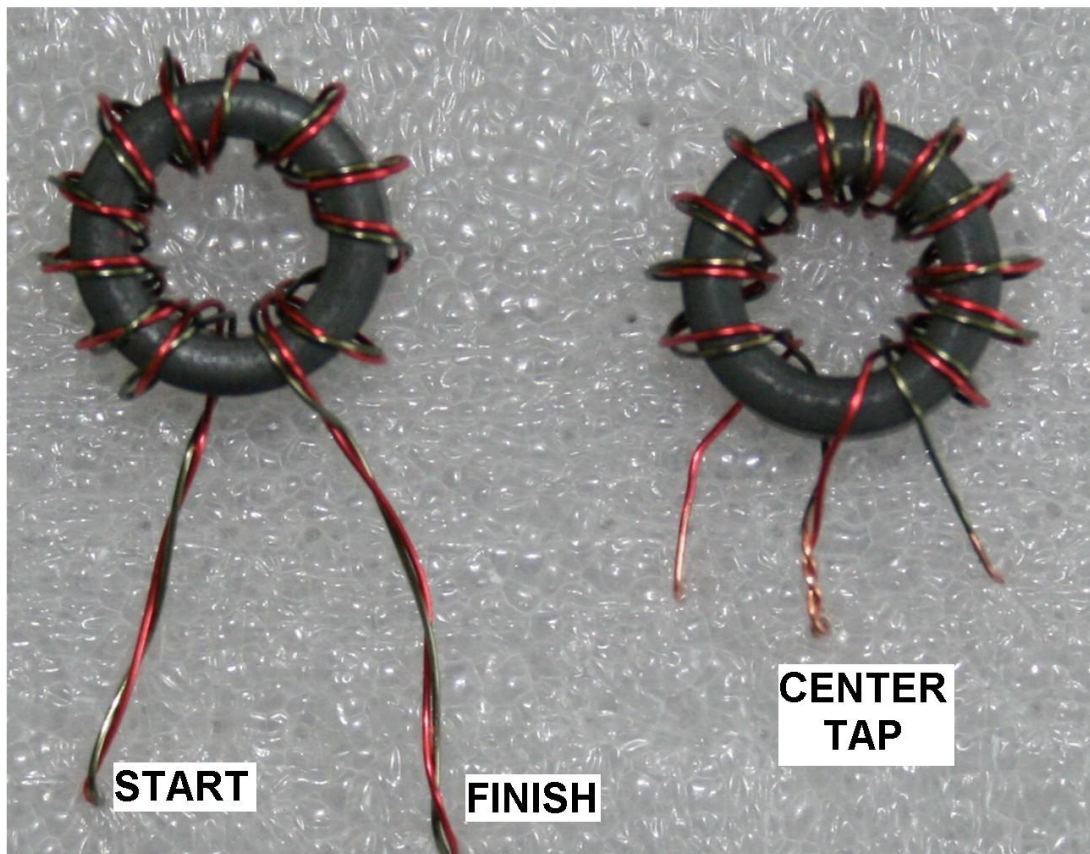
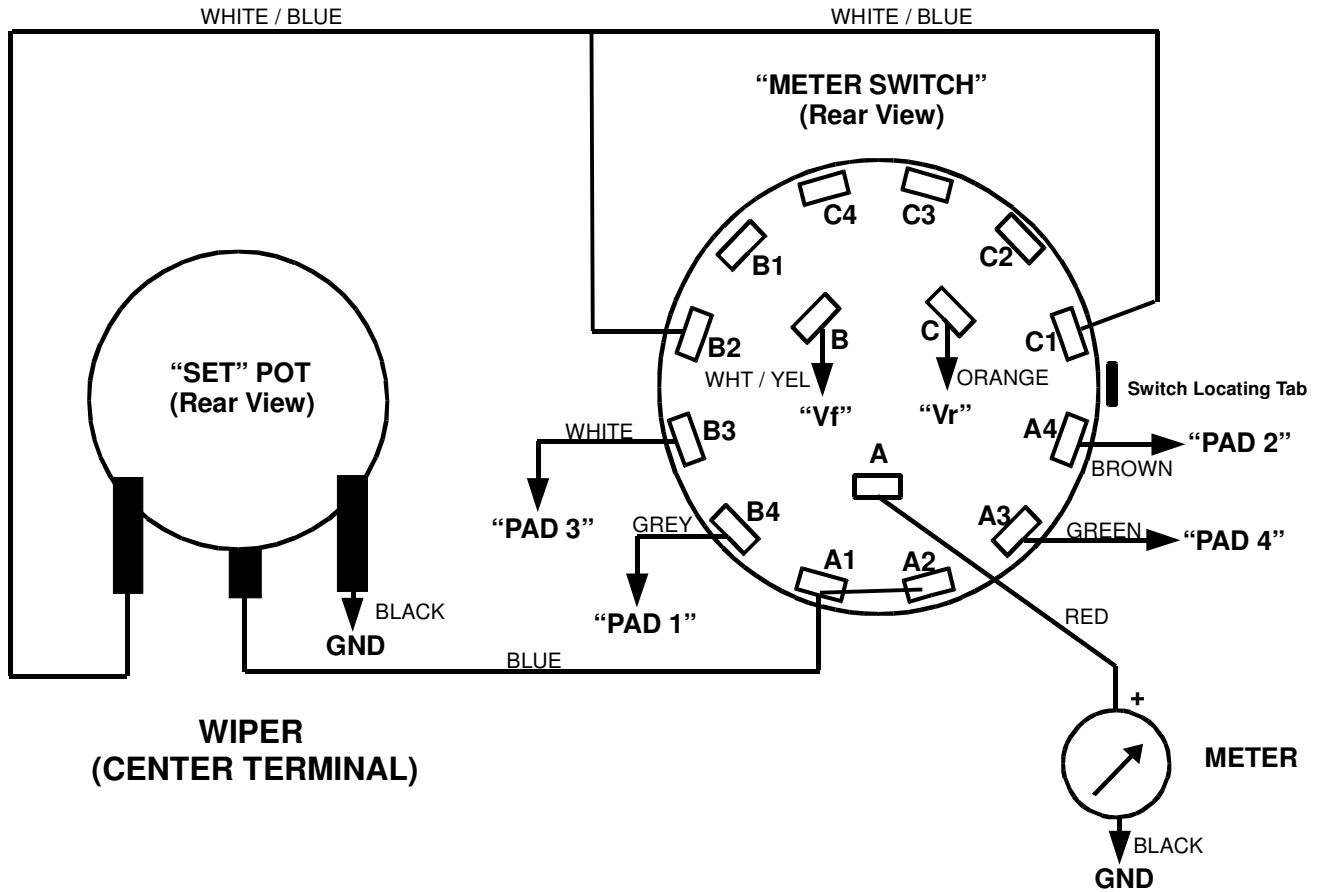

FIGURE 3
Proper winding of Toroid T1

PHASE III: METER SWITCH & SWR SET POT ASSEMBLY WIRING

OVERVIEW

In this section, the meter switch and SWR Set pot will be pre-wired. It is much easier to wire these prior to installing them into the chassis. The meter switch can most easily be identified by looking at the contacts on the rear. There will be 12 solder contacts around the the edge with three solder contacts, arranged in a triangle, in the center area. The pin designators are shown below, along with a wiring diagram:



The assembly process consists of pre-cutting hookup wire to interconnect the switch and "Set" pot as well as creating a small cable harness to connect to the SWR Bridge which will mount to the rear panel of the tuner.

In preparation for wiring the switch and “Set” pot, prepare the following wires by cutting them to the indicated length and then stripping 1/4” of insulation off each end except where noted differently:

1. □□ 3-1/4” Red wire
2. □□ 3” Blue wire (strip 1/2” of insulation off one end and 1/4” off the other end)
3. □□ 9-1/4” Green wire
4. □□ 9-1/4” Brown wire
5. □□ 9-1/2” White / Yellow wire (white wire with a yellow tracer)
6. □□ 3” White / Blue wire
7. □□ 1-1/4” White / Blue wire
8. □□ 10-1/4” White wire
9. □□ 8-3/4” Grey wire
10. □□ 8-1/4” Orange wire
11. □□ 5” Black wire

Orient the switch and “set” pot in front of you as shown in the previous drawing. The pre-cut wires will now be connected and soldered. Each connection, if it is to be soldered, will be marked (Sx) where “x” is the number of wires at the joint being soldered. If there is only a single wire, the indication will be (S1). If a wire passes through a joint, it will be considered as two wires and marked (S2). (NS) means do not solder at this time.

Connect the pre-cut wires as follows:

1. □□ 3-1/4” Red wire to Terminal “A” of the switch (S1)
2. □□ 3” Blue wire to A1 (S2) & A2 (S1) of the switch and the center terminal of the “Set” pot (S1)
3. □□ 9-1/4” Green wire to Terminal “A3” of the switch (S1)
4. □□ 9-1/4” Brown wire to Terminal “A4” of the switch (S1)
5. □□ 9-1/2” White / Yellow wire (white wire with a yellow tracer) to Terminal “B” on the switch (S1)

6. □□ 3" White / Blue wire from Terminal "B2" of the switch (NS) to the left hand terminal of the "Set" pot (viewed from the rear) (S1)
7. □□ 1-1/4" White / Blue wire to Terminal "B2" of the switch (S2) and Terminal "C1" of the switch (S1)
8. □□ 10-1/4" White wire to Terminal "B3" of the switch (S1)
9. □□ 8-3/4" Grey wire to Terminal "B4" of the switch (S1)
10. □□ 8-1/4" Orange wire to Terminal "C" of the switch (S1)
11. □□ 5" Black wire to the right hand "GND" terminal of the "Set" pot (S1)

Set the switch and pot assembly to the side for the moment while the antenna switch assembly is prepared.

PHASE IV: ANTENNA SWITCH WIRING

The antenna switch assembly is most easily installed if the antenna switch is pre-wired. This is accomplished after mounting the switch onto it's associated bracket, Part # 93957.

Install the switch, with it's mounting tab through the hole in the bracket, with an M9 x 0.75 metric nut and flat washer as shown in Figure 1. (The nut and flat washer may come assembled on the switch)

As with the meter switch, hook-up wire will be pre-cut and soldered to the switch before final chassis assembly. The switch wiring diagram is shown below:

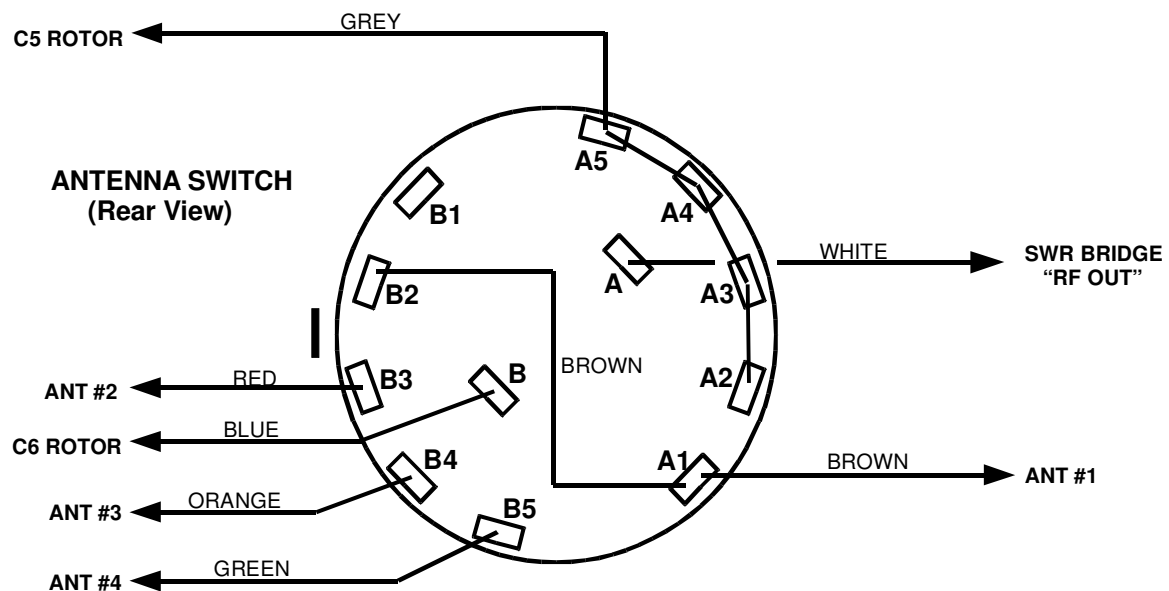

Prepare the following wires by cutting them to the indicated length and then stripping 1/4" of insulation off each end, except where noted differently:

1. 4-1/2" White wire
2. 1-1/4" Brown wire
3. 2" Brown wire
4. 8" Grey wire (strip 1" of insulation off one end and 1/4" off the other)
5. 4-3/4" Blue wire
6. 2-1/2" Red wire
7. 2-1/2" Orange wire
8. 3-1/4" Green wire

Refer to the drawing on the previous page to connect the wires to the Antenna Switch.

1. 4-1/2" White wire to Terminal "A" of the switch (S1)
2. 1-1/4" Brown wire to Terminal "B2" of the switch (S1) and Terminal "A1" (NS)
3. 2" Brown wire to Terminal "A1" of the switch (S2)
4. 8" Grey wire – route the 1" stripped end through Terminal "A5" (S2) to Terminal "A4" (S2) to Terminal "A3" (S2) to Terminal "A2" (S1)
5. 4-3/4" Blue wire to Terminal "B" of the switch (S1)
6. 2-1/2" Red wire to Terminal "B3" of the switch (S1)
7. 2-1/2" Orange wire to Terminal "B4" of the switch (S1)
8. 3-1/4" Green wire to Terminal "B5" of the switch (S1)

PHASE V: CHASSIS ASSEMBLY & WIRING

In this section, all of the components will be mounted onto the chassis and interconnections made.

METER SWITCH AND SWR “SET” POT INSTALLATION

1. Remove the nut and flatwasher from the meter switch.
2. Re-install the nut on the switch and thread it approximately halfway down the bushing.
3. Install the switch into the lower left hand hole on the front panel with the “A” terminal toward the bottom of the chassis. Install the flatwasher onto the bushing and an M9 x 0.75 metric nut over that. If the bushing protrudes through the nut or if there is not enough bushing showing to thread the nut onto, remove the switch and adjust the “inside” nut in or out to set the amount of bushing protruding through the front panel. When the outside nut is installed, it should be essentially flush with the end of the bushing. A little variation, either way, is acceptable. **NOTE:** *a 3/8” nut will fit on the switch, but will appear to be a bit loose. The metric nut is slightly smaller. Make sure that the correct nut is used or the switch will loosen up later!*
4. Tighten the external nut securely with a crescent wrench or nut driver, taking care not to scratch the front panel paint.
5. Remove the nut and flat washer from the “SET” pot and install the pot into the front panel with the locating tab in the small hole below the main control hole. Place the flat washer and nut over the bushing protruding through the front panel and tighten. Take care not to scratch the paint on the front panel.
6. Locate the meter bracket (part # 93956), lamp socket and a #4 solder lug.
7. Using a 1/4” 4-40 screw, nut and lockwasher, fasten the lamp socket to the bracket as shown in Figure 1 in the Appendix. The solder lug should be placed between the meter bracket and lamp socket and oriented to face toward the middle of the chassis. Place the lockwasher inside the meter bracket, under the nut. Tighten securely.
8. Place the meter in the front panel hole and then attach the meter bracket to the bottom of the chassis using two 3/8” 4-40 screws, lockwashers and nuts. Insert the screws up through the bottom of the chassis.

9. Solder the red lead from the meter switch to the “+” terminal of the meter. (S1)
The “+” terminal is the one toward the center of the chassis.
10. Attach the black ground lead from the “SET” pot to the solder lug on the rear of the meter bracket. (NS)
11. Cut a 3-3/4” piece of black wire and strip 1/4” of insulation off each end.
12. Solder one end of the black wire to the meter “-” terminal and connect the other end to the solder lug on the rear of the meter bracket. (NS)
13. Locate the previously assembled SWR Bridge board.
14. Remove the two 4-40 screws from the SO-239 connector and then insert the connector from the inside of the chassis through the rear panel hole labeled “RADIO”.
15. Secure the connector to the rear panel using the two screws previously removed. Tighten securely.
16. Locate the 2.1mm DC power connector.
17. Prepare a 6-3/4” Red and a 5-1/2” Black wire. Strip 1/4” of insulation from each end.
18. Solder one end of the Red wire to the “+” terminal of the DC connector (S1).
See drawing.
19. Solder one end of the Black wire to the “-” terminal of the DC connector (S1).
See drawing.

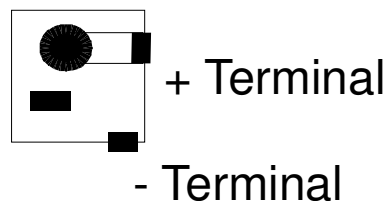

20. Install the connector from the inside of the rear panel and attach it using two 1/4” 2-56 screws and nuts.
21. Connect the black wire from the DC connector to the solder lug on the meter mounting bracket, by the pilot lamp mounting screw. (NS)

22. Solder the red wire from the DC connector to the solder lug at the base of the lamp socket. (S1)
23. Locate the four remaining SO-239 antenna connectors.
24. Install the connectors at “Ant 1”, “Ant 2”, “Ant 3” and “Ant 4”. Use two 4-40 x 3/8” screws with attached split washers and two nuts at each location. Tighten securely.
25. Using a #10 x 3/4” screw, attach a #10 solder lug to the inside of the chassis at the hole marked “GROUND”. Use a #10 lockwasher and nut on the outside of the chassis.
26. Install two #10 flat washers and a wing nut on the threaded end of the GROUND screw.
27. Locate six of the #90861 Feed Thru Insulators, three #10 solder lugs, three #10 x 1-1/4” screws, three #10 nuts, six #10 flat washers and three Wing Nuts.
28. At each of the single or balanced wire feed points, install an insulator on each side of the rear chassis. Slip a #10 solder lug over a #10 x 1-1/4” screw and insert it into the feedthru from inside the chassis.
29. Outside the chassis, slip a #10 flat washer and a #10 lockwasher onto each of the three screws. Follow that with a #10 nut. Tighten securely.
30. Install two #10 flat washers and a wing nut on the threaded ends of the #10 screws protruding through the feedthru insulators on the rear of the chassis.
31. Locate the two black plastic 1/4” snap in bushings. From the front of the front panel, insert one into the “Antenna” selector hole and the other in the “Inductance” hole.
32. Install the antenna switch behind the “Ant 1” connector. Screw it to the chassis floor using two 4-40 x 3/8” screws, lockwashers and nuts. Feed the screws in from underneath the chassis.
33. Attach the insulated 1/4” coupler to the shaft of the antenna switch using one of the black 6-32 x 3/16” screws.

34. Insert the 1/4" diameter, 3-1/4" long insulated shaft through the front panel and into the coupler on the antenna switch and tighten it down using a black 6-32 x 3/16" screw.

CHASSIS WIRING (Refer to Figure 4)

1. Solder the Grey wire from the meter switch to "Pad 1" (S1) on the SWR board. Route the wire from the meter switch over to the left edge of the chassis, along the edge to the rear and then up to the SWR board.
2. Solder the Brown wire from the meter switch to "Pad 2" (S1) on the SWR board. Route the wire as before.
3. Solder the White wire from the meter switch to "Pad 3" (S1) on the SWR board. Route the wire as before.
4. Solder the Green wire from the meter switch to "Pad 4" (S1) on the SWR board. Route the wire as before.
5. Solder the Orange wire from the meter switch to "Vr" (S1) on the SWR board. Route the wire as before.
6. Solder the White / Yellow wire from the meter switch to "Vf" (S1) on the SWR board. Route the wire as before.
7. From the antenna switch, solder the following (Refer to Figure 1)
 1. Brown wire to the "Ant 1" connector center pin. (S1)
 2. Red wire to the "Ant 2" connector center pin. (S1)
 3. Orange wire to the "Ant 3" connector center pin. (S1)
 4. Green wire to the "Ant 4" connector center pin (NS).
 5. White wire to the "RF Out" pad on the SWR board. (S1)
8. The Grey and Blue wires will be connected later.
9. Cut a 1-1/2" piece of white hookup wire and remove all the insulation from it.

10. Solder one end to the center pin of the "Ant 4" connector (S2) and connect the other to the solder lug on the "Single Wire" feedthru insulator (S1).
11. Prepare a 7" black wire and solder one end to the "GND" pad on the SWR board (S1) and the other end to the ground lug on the meter bracket (S4).
12. Install the variable inductor bracket to the chassis using two 4-40 x 3/8" screws, nuts and one lockwasher. Place a #4 solder lug on the screw closest to the right hand side of the chassis, as viewed from the front. See Figure 1 and the drawing below for reference.
13. Set the inductor wiper to the right (3:00 position) and connect the loose end of the braid attached to the inductor shaft to the ground lug at the base of the mounting bracket (NS). Dress the braid as shown on the drawing below.
14. Take the coil pigtail closest to the bracket of the variable inductor and bring it over to the solder lug where the braid is attached. Connect it to the lug and solder the lug solidly. (S2)

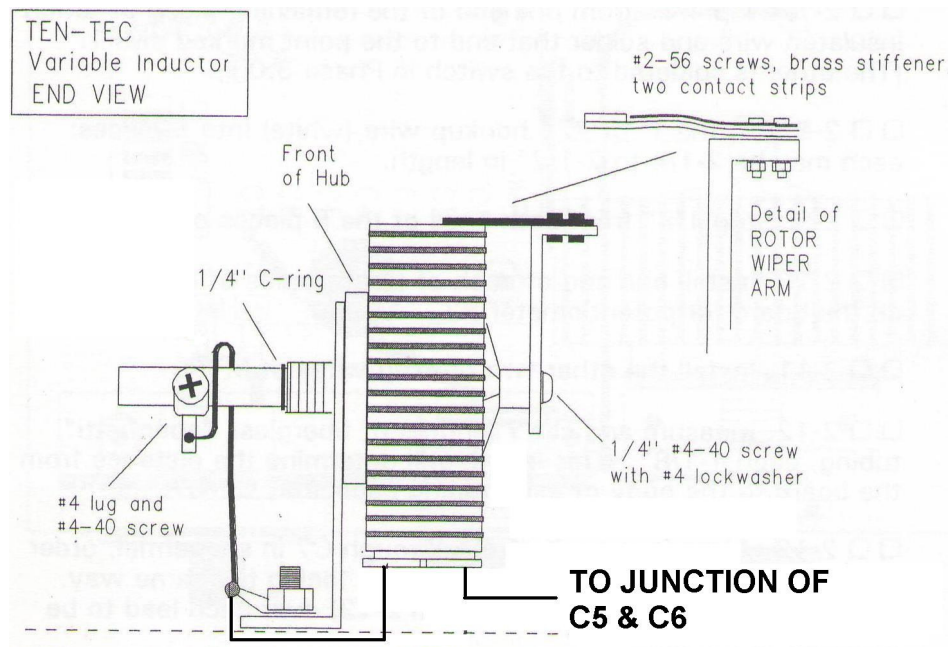

15. Locate the two variable capacitors, C5 & C6 (they are identical).
16. Locate four 5/8 x 3/8" white fiber shoulder washers, four 3/8" flat washers and four 3/8" nuts. **NOTE:** There may be a 3/8" nut and flatwasher already installed on the shaft of the variable capacitors. If so, remove them.

17. On each variable capacitor, install a 3/8" nut all the way onto the bushing and then slide a flatwasher onto the bushing. Take a fiber shoulder washer and slide it on the bushing so that the raised portion in the center faces away from the capacitor.
18. At the rear of each of the capacitors there will be two solder lugs which point straight down. Bend each of them upwards against the ceramic so that they point out the rear of the capacitor.
19. Install the lower variable capacitor "upside down" so that the long solder lug at the rear end is closest to the bottom of the chassis. Insert the shaft of the capacitor through the front panel hole and then insert a fiber shoulder washer from the front followed by a 3/8" flat washer and nut. Ensure that the shoulder washers are seated in the panel and tighten the front nut securely. As a quick check, using an ohmmeter, check the resistance from the front panel nut to the chassis. It should show as an open circuit. If not, loosen the front nut and re-seat the shoulder washers.
20. Install the upper capacitor "right side up" and follow the mounting instructions in Step 17. Perform the same resistance check.
21. At the rear of the two capacitors are two solder tabs connected to the stator (stationary) plates of the capacitor. The two tabs for the upper capacitor should almost be touching the the two tabs for the lower capacitor.
22. Take the free pigtail from the variable inductor and feed it through the upper and lower stator tabs toward the center of the chassis. Wrap the wire through the tabs and solder it. (S1) (See Figure 1 for reference)
23. Press the two stator tabs on the outside edge of the chassis together and solder them. It may help to slightly squeeze the two capacitors together to get the tabs to touch while soldering. (S0 – No wire connected to this point)
24. Solder the Blue wire from the antenna switch to the rear rotor solder lug of the lower capacitor. (S1) (See Figure 1 for reference)
25. Solder the Grey wire from the antenna switch to the rear rotor solder lug of the upper capacitor. (S1) (See Figure 1 for reference)

FINAL CHASSIS ASSEMBLY

1. Set each of the variable capacitors to maximum capacitance (plates fully meshed).
2. Locate the two mid-sized knobs and loosen their setscrews and place each on one of the variable capacitors.
3. With the plates still meshed, rotate the knobs until their pointers point to the “10” on the scale. Tighten the setscrews.
4. Rotate the variable inductor fully counter-clockwise. Place a large knob on the shaft and tighten the setscrew with the knob pointing at “0”.
5. Rotate the antenna switch fully counter-clockwise and then clockwise two clicks. Attach a large knob with the pointer set at “2” and tighten the setscrew.
6. Rotate the SWR SET potentiometer fully counter-clockwise and install a small knob on it's shaft. Set the pointer to the lower left “dot” on the front panel and tighten the setscrew.
7. Rotate the Meter Switch fully counter-clockwise and place a small knob on the shaft. Align the pointer to “SWR” and tighten the setscrew.
8. Locate the jumper bar supplied with the kit. This is used to jumper the “Single Wire” terminal on the rear panel to the adjacent “Balanced Line” terminal when a balun is installed inside the 1215. If no balun is installed, this bar can be left jumpering those two terminals. If a balun is installed and a single wire feed antenna is used, the jumper must be removed or left hanging on one of the “Balanced Line” terminals so that it doesn't get misplaced. ***Hint: Install the bar with the “closed” end on the upper “Balanced Line” terminal and let it hang down. If left hanging from the “Single Wire” terminal, it can short against the “Ground” terminal.***
9. Install the lamp into the bayonet socket behind the meter.

PHASE VI: WATTMETER CALIBRATION & CHECKOUT

Required Tools / Equipment:

- Small flat blade screwdriver
- Radio Transmitter capable of providing up to 100 watts or more
- 50 Ohm load capable of handling 100 watts

Calibration of the wattmeter portion of the 1215 Tuner is a straight forward process:

If your radio has a built in wattmeter, proceed directly to Step 1. If the radio does not have a built in wattmeter, there are two alternatives:

- Connect a calibrated wattmeter between the radio and the tuner. Proceed to Step 1 below.
 - Utilize the “Calibration Utilizing DC voltage” procedure at the end of this manual.
1. Connect the 50 Ohm load to the Antenna #1 connector.
 2. Connect the radio transmitter to the Radio connector on the 1215
 3. Set the 1215 Meter switch to “200 Watts” and select “Bypass”.
 4. Key the transmitter on 20 meters and adjust the power to 200 watts, or 100 watts if that is what it is rated at. Use the highest power available for this calibration as that will produce the most accurate results.
 5. Adjust the “200W” pot on the top right of the SWR board so that the wattmeter reading corresponds to the applied power.
 6. Reduce the radio power to 20 watts
 7. Set the 1215 Meter switch to “20 Watts”
 8. Key the radio and adjust the “20W” pot on the top left of the SWR board so that the wattmeter reads 20 watts.
 9. This completes calibration of the 1215 Tuner wattmeter. Disconnect the radio and load and install the cover using four 4-40 x 3/16” black flat head screws.

CALIBRATION USING DC VOLTAGE

If no means of measuring RF power is available, the 1215 wattmeter can be calibrated, although with reduced accuracy, by injecting a known DC voltage into the “Vf” pad on the circuit board and adjusting the 20 and 200 watt pots. The transmitter must remain off during this calibration.

An external DC power supply or a home made DC source can be used to calibrate the wattmeter.

A DC voltage source can be constructed using a 9 volt battery and a 10k Ω potentiometer (not supplied with the kit) connected as follows:

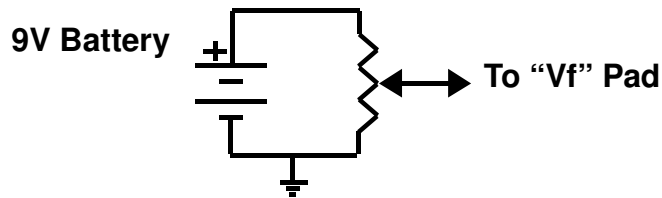

Connect the “ground” side to the tuner chassis (a clip lead is a good way to do this). Connect the wiper of the potentiometer (or the positive output from the variable power supply) to the “Vf” pad on the circuit board. An easy way to accomplish that is to connect a clip lead from the wiper of the pot to the banded end (cathode) of diode D1.

Set the meter switch to “200W” and, using a digital voltmeter with the negative lead connected to the tuner chassis, adjust the voltage at the “Vf” pad to 5.80 volts. Adjust the “200W” pot on the upper right of the SWR circuit board until the meter reads 200 watts.

Reduce the DC voltage at the “Vf” pad to 1.70 volts and switch the meter to the “20W” scale. Re-check the DC voltage after switching scales and readjust if necessary. Adjust the “20W” pot on the top left of the SWR board for a reading of 20 watts.

Remove the DC voltage source. The calibration is complete.

This completes calibration of the 1215 Tuner wattmeter. Disconnect the radio and load and install the cover using eight 4-40 x 1/4” black flat head screws.

OPERATIONAL TEST

This is a quick functional test to ensure that the 1215 is wired correctly and functioning normally. For this test, use one of your actual antennas and select a frequency where the SWR is greater than 1:1.

1. Connect your radio to the "RADIO" port on the rear of the tuner.
2. Connect an antenna to the "ANT 1" port on the rear of the tuner.
3. Set the meter switch to "200W" and the Antenna switch to "BYPASS"
4. Key the radio – all indications should be the same as they were before the tuner was installed since the radio is connected directly to the antenna on the "ANT 1" port.
5. Set the meter switch to "SET" and key the transmitter in the CW mode.
6. Adjust the "SWR SET" pot for a full scale meter reading.
7. Change the meter switch to "SWR" and note the SWR reading on the meter.
8. Reduce the transmitter power to approximately 20 watts and de-key it.
9. Change the Antenna switch to the "ANT 1" position.
10. Perform the tuning procedure as described in the "OPERATING TIPS" section of this manual (Page 12).
11. If the tuning procedure is successful, move your antenna to the "ANT 2" connector, change the Antenna switch to "ANT 2" and check to see that everything is working as it was with the antenna connected to the "ANT 1" port.
12. Repeat Step 11 for antenna ports 3 and 4.

If any difficulties are encountered during this check-out, re-check all of the wiring for accuracy and ensure that all connections are soldered. If the Wattmeter / SWR functions worked correctly during the test in the "BYPASS" position, then there are no problems with the SWR Board, the wiring of the meter switch or the "Set" pot.

If the tuner works on some, but not all, positions of the "ANTENNA" switch, check the wiring of that switch. Use the "Troubleshooting Chart" section of the manual (Page 13) to aid in locating any problems.

APPENDIX

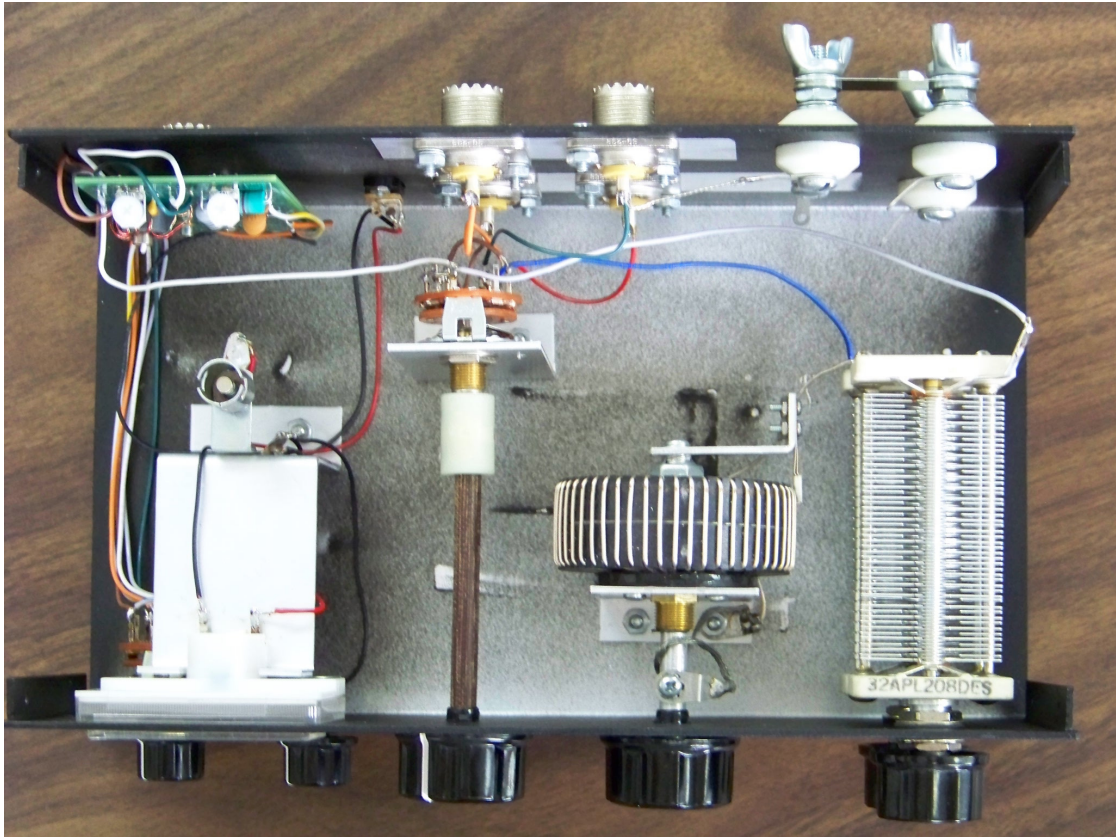

FIGURE 1 – TOP VIEW OF TUNER

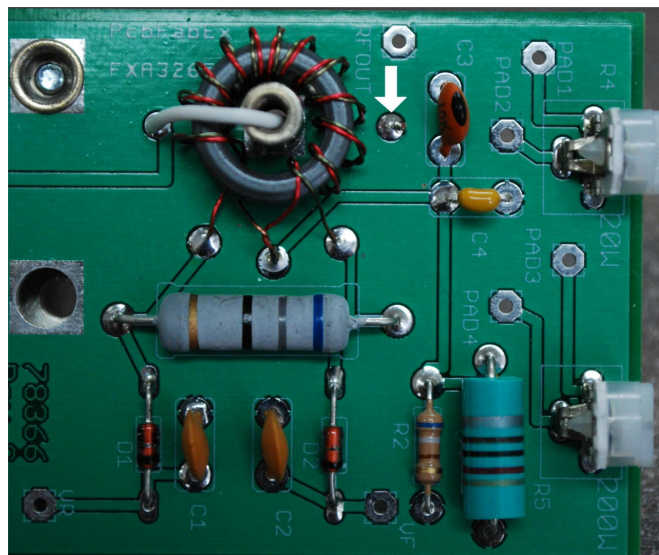

FIGURE 2 – SWR BOARD LAYOUT

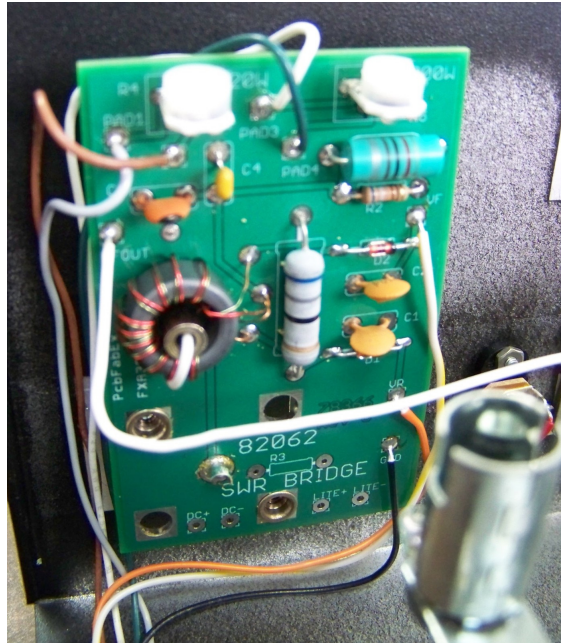

FIGURE 4 – SWR BRIDGE WIRING



FIGURE 5 – REAR PANEL

TEN-TEC KIT LIMITED WARRANTY
Please read carefully BEFORE building your kit.

This Limited Warranty applies solely to kits sold by TEN-TEC, Inc. The terms of this Warranty do not apply to other products of any kind manufactured by TEN-TEC, Inc., nor shall any other warranties published by TEN-TEC, Inc., or any TEN-TEC customer service policies for its manufactured products, be construed as applicable to kit products.

1. All components and hardware supplied as parts of a kit are warranted to be free from manufacturing defects for one year from date of purchase.
2. The original purchaser has the option of examining the kit and manual for 30 days. If you choose within this period not to construct the kit, you may return the entire unassembled kit at your own expense for full credit toward any other TEN-TEC product, or a refund, less original shipping / handling charges, providing that the parts package(s) have not been opened.
3. This warranty is void if acid-core solder is used in construction. Use ROSIN CORE solder only, of a grade designed for electronic PC-board assembly.
4. TEN-TEC, Inc. warrants this device to function as described in its documentation provided that it is assembled and used correctly in accord with all printed directions. It is your responsibility to follow all directions in the instruction manual, to identify components correctly and to use good workmanship and proper tools in constructing this kit.
5. We do not accept the return of partially-assembled kits for refund.
6. If you believe a kit part is missing, do a thorough sorting of all parts, checking each off on the parts list in the manual. Check all bags, boxes and envelopes carefully. Simply call, email or FAX our service department at (865) 428-0364 (Voice), (service@tentec.com) or (865) 428-4483 (FAX) and we will promptly replace any missing part.
7. If your kit does not work after final assembly, please follow these steps:
 1. Double check every step in the assembly manual and any troubleshooting tips provided.
 2. If the above does not resolve the issue, contact the TEN-TEC service department at (865) 428-0364 or via email at service@tentec.com
8. **Factory Inspection or Service:** If you wish to return a kit for professional inspection or repair, simply send your kit along with a note explaining the problem. Please include a daytime phone number and email address. Charges for repairs will be at the prevailing shop rate. A Return Authorization is not required prior to sending a product in for repair. If we find that a part was defective in manufacture, there will be no charge to repair your kit. Our technicians will make the determination whether a part was defective in manufacture or was damaged during installation. We recommend calling our service department first to see if the problem can be resolved over the phone.
9. TEN-TEC, Inc. reserves the right to revise this Limited Warranty, to change or discontinue any kit product or revise its instruction manual with no liability to previous purchasers.
10. TEN-TEC, Inc., is not liable for any consequences from use or abuse of any kit or part contained therein.

TEN-TEC, INC.
1185 Dolly Parton Parkway
Sevierville, TN 37862
(865) 453-7172
www.tentec.com