

SHURE[®]
THE SOUND OF THE PROFESSIONALS[®] WORLDWIDE

222 HARTREY AVE., EVANSTON, IL, 60204 U.S.A.
AREA CODE 312/866-2200 • CABLE: SHUREMICRO
TWX: 910-231-0048 TELEX: 72-4349

MICROPHONES AND ELECTRONIC COMPONENTS

DATA SHEET
MODEL 526T SERIES II
Super Punch[®]
MICROPHONE

TRANSISTORIZED BASE STATION MICROPHONE



GENERAL

The Shure Model 526T Series II SUPER PUNCH[®] base station microphone is designed for clearer transmission and improved reliability. This transistorized microphone can be used to replace ceramic or dynamic, high- or low-impedance microphones supplied as original equipment.

Model 526T Series II provides crisp, undistorted voice response with adjustable volume control for optimum intelligibility of transmission.

The microphone is designed for maximum versatility in base station operation. It has a momentary or locking press-to-talk transmit/receive switch for greatest ease of use, and a modulation level volume control for highest undistorted output with high- or low-impedance inputs. The supplied six-wire cable and triple-pole double-throw switch are arranged for universal microphone-transceiver connection.

The microphone is not affected by heat or humidity, and it is outstanding in its ability to resist mechanical shocks and vibration. Its exclusive ARMO-DUR[®] case is immune to oil, grease, fumes, salt spray, sun, rust, and corrosion. The "Million-Cycle" leaf-type press-to-talk switch is designed to withstand rigorous operating conditions and constant use.

Microphone Features:

- Dynamic microphone with transistorized preamplifier
- Adjustable volume control for optimum transmitter modulation and maximum intelligibility

- Replaces either ceramic or dynamic original equipment microphones
- Excellent response for single-sideband transmission
- Uses readily available 9-volt battery — low current drain for long life
- Low hum pickup, minimum susceptibility to RF interference
- Momentary or locking press-to-talk transmit/receive switch — "Million-Cycle" leaf-type
- Universal six-wire cable for instant microphone-transceiver connection
- Sturdy, high-impact ARMO-DUR case
- Rugged and dependable under all operating conditions

BATTERY INSTALLATION

Model 526T Series II uses a 9 Vdc battery (Eveready 216 or equivalent—supplied). To install the battery, proceed as follows:

1. Loosen two screws (located underneath base) holding battery retaining clip, and remove battery retaining clip.
2. Connect terminal strap to battery.
3. Insert battery in VELCRO strap of battery retaining clip and fasten VELCRO strap.
4. Insert battery retaining clip in base and tighten screws securely.

CONNECTIONS

Model 526T Series II can be connected to an input (of a transceiver, transmitter, or amplifier) of 500 ohms or more. Refer to the Shure CB and Amateur Radio Wiring Guide enclosed with the microphone for detailed instructions for connecting the 526T Series II to CB or ham transceivers. If your unit is not listed in the Guide, contact your dealer or Shure Brothers Incorporated for information.

A piece of tubing is attached to the plug end of the cable for use as a strain relief for plugs with large cable entry holes. Remove the tubing when not required.

The internal connections of Model 526T Series II are shown in Figure 1.

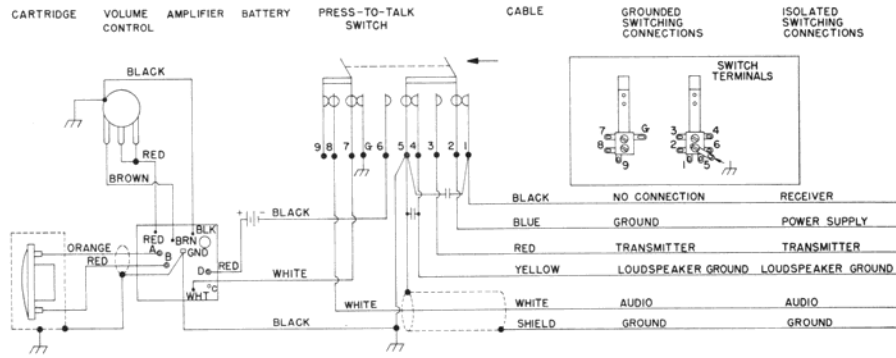

INTERNAL CONNECTIONS
FIGURE 1

The general wiring procedure for transceiver connections is as follows.

Microphone Audio Input Circuit:

1. Connect the WHITE cable lead to the microphone audio input terminal.
2. Connect the SHIELD to chassis or circuit ground of the transceiver (see Guide and CAUTION below).

Electronic or Relay Switching Circuit:

GROUNDING SWITCHING

Most transceivers employ a *grounded* circuit to switch from the receive to the transmit position. To connect the microphone to such a circuit, proceed as follows.

1. At the end of the cable, connect the RED lead to the terminal used to complete the transmitter circuit.
2. Connect the BLUE lead to chassis or circuit ground of the transceiver (see Guide and CAUTION below).
3. Connect the YELLOW lead to the terminal used to complete the receiver circuit. This will usually be a ground return from the loudspeaker circuit. If a microphone switching contact is not required for the loudspeaker ground, insulate (wrap with tape) the YELLOW lead.
4. The BLACK lead is usually not used; insulate the BLACK lead. However, if both a receiver ground and a loudspeaker ground are required, connect the YELLOW lead to loudspeaker ground, and the BLACK lead to the receiver ground.

ISOLATED SWITCHING

In some transceivers, an *isolated* circuit is required to switch power supply voltages rather than grounds. If an isolated switching circuit is required, proceed as follows.

1. At the end of the cable, connect the RED lead to the isolated switch contact terminal used to complete the transmitter circuit.
2. Connect the BLUE lead to the terminal used for the switched power supply.
3. Connect the BLACK lead to the terminal used to

complete the receiver circuit. If the power supply is not switched to the receiver circuit by a microphone switching contact, insulate (wrap with tape) the BLACK lead.

4. Connect the YELLOW lead to the loudspeaker *ground return*. If a microphone switching contact is *not* required for the loudspeaker *ground*, insulate the YELLOW cable lead.

CAUTION

Make certain that the SHIELD and/or the BLUE lead are not connected to chassis ground for those models where the Guide specifies they should be connected to circuit ground.

SPECIAL SWITCHING

In some transceivers, special switching circuits are required. Three types are described below. In all of the types, before making the required circuit alterations, remove the microphone baseplate by unscrewing the two screws securing it.

1. If a grounded audio input is required in the receive mode, solder a jumper lead between switch terminal 9 and the ground lug (see Figure 1).
2. If both an isolated and grounded transmit circuit are required, along with a grounded receive circuit (see Figure 1):
 - A. Unsolder the WHITE leads from switch terminals 7 and 8.
 - B. Solder the WHITE leads together, and insulate the connection.
 - C. Cut the BLACK cable lead from terminal 1 and solder it to terminal 8.
 - D. Solder a jumper lead between terminal 7 and the ground lug.

At the end of the cable, the BLUE and RED leads are now the isolated transmit leads; the BLACK lead is the grounded transmit lead; and the YELLOW lead is the grounded receive lead.

3. If both an isolated and grounded receive circuit are required, along with a grounded transmit circuit (see Figure 1):
 - A. Unsolder the WHITE leads from switch terminals 7 and 8.

- B. Solder the WHITE leads together, and insulate the connection.
- C. Unsolder the RED cable lead from terminal 3 and solder it to terminal 8.
- D. Solder a jumper lead between terminal 7 and the ground lug.

At the end of the cable, the BLACK and BLUE leads are now the isolated receive leads; the YELLOW lead is the grounded receive lead; and the RED lead is the grounded transmit lead.

VOLUME CONTROL

When the 526T Series II replaces a dynamic (usually low-impedance) microphone supplied as original equipment, the volume control should be set at the lower ranges to prevent overmodulation and unintelligible transmission. Correct modulation can be checked on the modulation level indicator.

When the 526T Series II replaces a ceramic (usually high-impedance) microphone supplied as original equipment, the volume control should be set at the upper ranges for correct modulation as indicated on the modulation level indicator.

WARNING

Too high a volume control setting causes overmodulation, interference, channel splatter, and unintelligible voice transmission. Carefully check the volume control setting.

LOCKING PRESS-TO-TALK SWITCH

The fingertip control bar of the press-to-talk switch can be used in a momentary or locked-on position. For use as a momentary switch, depress the control bar and release after transmission. To lock the switch in the On position, depress the control bar and move it forward with the fingertips. To unlock the switch, move the control bar backward and remove pressure.

SPECIFICATIONS

Type

Dynamic (with transistor preamplifier)

Frequency Response

200 to 6,000 Hz (see Figure 2)

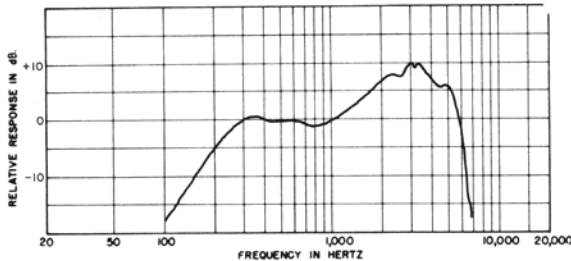

TYPICAL FREQUENCY RESPONSE
FIGURE 2

Polar Pattern

Omnidirectional

Output Impedance

5,000 ohms

Load Impedance

500 ohms minimum

Output Level (at 1,000 Hz with 100 kilohm load)

Adjustable from 0.61 to 16 mV for 1 microbar input

Signal Handling Capability (with 50 kilohm load)

111 dB SPL at 1,000 Hz produces 1.0V with volume control at maximum

Battery Type

9 Vdc (Eveready 216 or equivalent)

Battery Drain

0.9 mA

Battery Life

300 hours minimum, replace after 1 year

Switches

Press-to-talk: single-bar, momentary or locking, leaf-type triple-pole double-throw switch

Cable

2.1m (7 ft) five-conductor, one-conductor shielded, rubber jacketed, attached, coiled cable

Case

Black, high-impact ARMO-DUR®

Dimensions

See Figure 3

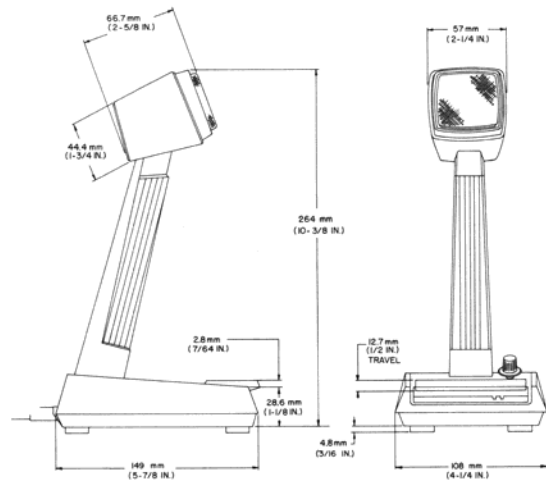

OVERALL DIMENSIONS
FIGURE 3

Net Weight

920 grams (2 lb)

Packaged Weight

1.2 kilograms (2 lb, 11 oz)

REPLACEMENT PARTS

Cartridge	R96
Grille Assembly	90D1844
Battery Retaining Clip	90A2351
Baseplate	53A1459A
Coiled Cable	70A544
Switch Blade Assembly (6-blade)	90A2595
Switch Blade Assembly (4-blade)	90A3510
Press-to-talk Control Bar	65A1279A
Volume Control	46A060
Printed Circuit Assembly	90A2721

FULL ONE-YEAR WARRANTY

Shure Brothers Incorporated ("Shure"), 222 Hartrey Avenue, Evanston, Illinois 60204, warrants to the owner of this product that it will be free, in normal use, of any defects in workmanship and materials for a period of one year from date of purchase. You should retain proof of date of purchase. Shure is not liable for any consequential damages. If this Shure product has any defects as described above, carefully repack the unit, have it insured, and return it prepaid to:

Shure Brothers Incorporated
Attention: Service Department
222 Hartrey Avenue
Evanston, Illinois 60204

If you are not in the United States, return the unit to your dealer or Authorized Service Center for repair. The unit will be repaired or replaced and returned to you promptly, and if it cannot be repaired or replaced, you may elect to receive a refund.