

Assembly Manual for the

VK POWERMASTER

K-3448

Reprinted in part by arrangement with Electronics Australia from the March, 1984 edition.

DICK SMITH
KIT



The VK Powermaster can deliver 14 amps continuously or up to 25 amps on an intermittent basis to power RF linear amplifiers.

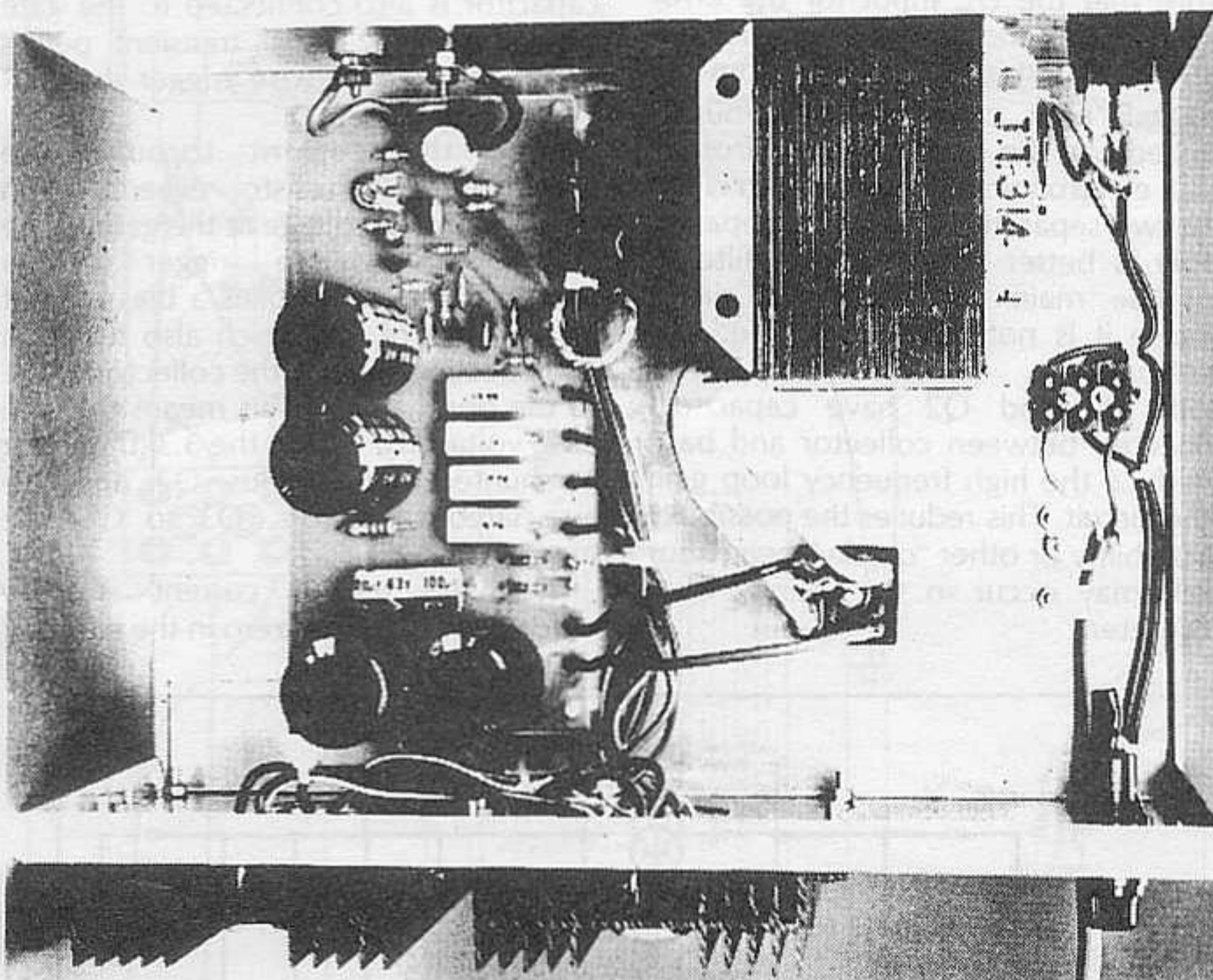

Photograph shows the view inside the prototype. Take care with mains wiring. Please note that the transformer is not included in the kit (option: JT-314 or M-2000).

that the capacitors on the circuit are "upside down" so that the positive rail is the reference or GND rail for the whole circuit.

When rectified and filtered, the 18VAC from the transformer secondary becomes around 25 to 27 volts DC. This is then fed to the regulator circuit which employs five transistors, one zener diode and one Darlington transistor for the basic regulator configuration, and an additional transistor and SCR for the short-circuit protection.

Trying to understand the circuitry in its entirety is a bit much though, especially as it is "upside down" to normal practice.

To make it easier to understand (and easier for the writer to describe), we have reproduced the same regulator configuration in Fig. 1 but with a conventional positive supply arrangement. This means that all transistor polarities in Fig. 1 are reversed to that of the actual circuit.

So Fig. 1 is a more-or-less conventional regulator circuit. Q3 is the main series pass transistor, Q2 is the driver transistor and Q1 is the error amplifier. It works like this: D1 provides a constant 6.2V DC reference at the emitter of Q1. Q1 compares this reference voltage with the sample of the 13.8V output voltage at its base and adjusts its collector current accordingly, thereby diverting base

The Powermaster design features instantaneous short-circuit protection which is attractive for a supply of this high rating. It is a completely discrete design with no integrated circuits being used. In itself this is of no particular moment but the alternative approach of the designer, Rex Callaghan, is an interesting one.

Design details

At first sight, the Powermaster design looks conventional enough. There they are, the four output transistors sharing the load by means of small resistors in series with their emitters. But wait a minute. The emitters are not connected to the load. The transistors look to be

back to front. In fact the whole design is upside down with the negative rail being controlled by the regulator element instead of the positive... Hmm.

Well now. We haven't really made a dreadful mistake. There is a reason for the upside-down approach and it has to do with the short-circuit protection which we will come to later. For the moment, let us go through the circuit, seeing where it is in fact quite conventional and then seeing where it departs from normal practice.

The front part of the circuit is certainly conventional with a transformer secondary winding feeding a 25-amp bridge rectifier and four 10,000 μ F electrolytic filter capacitors. Note though

Text and illustrations courtesy of Electronics Australia.

current for Q2 which is supplied via the 3.3kΩ resistor.

For example, if the output voltage tends to rise slightly it will raise the base voltage of Q1 by a proportional amount and so cause it to conduct more heavily. This will tend to turn Q2 off slightly and the same thing applies to Q3 and so the output voltage tends to fall back slightly.

The voltage divider feeding the base of Q1, comprising a 5.6kΩ and 4.7kΩ resistor plus 2kΩ trimpot, can be thought of as the DC gain control of the circuit. With a 6.2V reference and 13.8V output, the DC gain of the circuit is just over two. Since the ratio of the closed loop gain to the open loop gain (several thousand) is very large, the resultant regulation and ripple performance of the circuit is very good.

In fact it is every bit as good as could be expected from an integrated three-terminal regulator, if there was such a thing as a 25-amp three-terminal regulator.

Now have a look at the full circuit diagram again and note the similarities to Fig. 1. In Fig. 1, Q1 and Q2 are the direct equivalent of Q1 and Q2 (which is a Darlington for higher current gain). And Q3 on Fig. 1 is actually the equivalent of the four output transistors, Q3 to Q6.

The four output transistors, Q3 to Q6, are forced to share the load current by the following mechanism. First, all their bases are tied together while the emitters are also commoned via individual 0.1Ω 5W resistors.

If one of the Q3 to Q6 transistors starts to conduct more heavily than the others, due to a higher value of inherent current gain, its associated 0.1Ω emitter resistor will also carry more current and will have a higher voltage developed across it than the 0.1Ω resistor for the other three transistors. The higher voltage across the 0.1Ω current sharing resistor

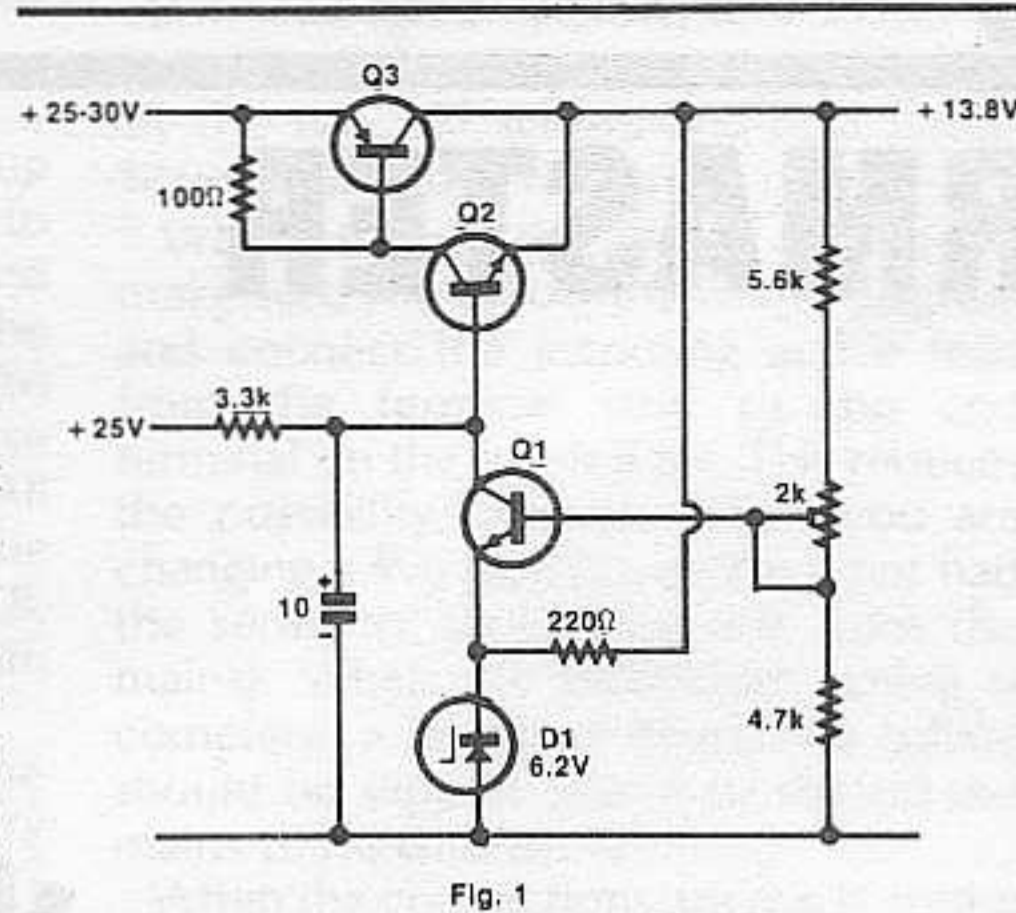

Fig. 1

will then effectively reduce the base-emitter voltage of the associated transistor and so it will be forced to conduct less current.

Note that the DC input for the error amplifier (Q1) and the bias drive for the Darlington (Q2) is not derived from the 40,000μF filter capacitor bank but is supplied via the 3.3kΩ resistor from a 100μF electrolytic capacitor which is fed from two separate diodes. This separate supply is better regulated and filtered than the main heavy current circuit because it is not required to feed the main load.

Both Q1 and Q2 have capacitors connected between collector and base to reduce the high frequency loop gain of the circuit. This reduces the possibility of instability or other "cranky" behaviour which may occur in the vicinity of a transmitter.

Good pulse output response is assured by virtue of the 1000μF and .047μF capacitors connected directly across the output circuit.

Short-circuit protection

We now come to the essential reason why this circuit is unconventional. Because there are four 0.1Ω resistors which are used to share the current equally among the four output transistors we have the means for sensing the total output current: just monitor the voltage across one of those four resistors and multiply the relevant value by 40 to obtain the actual current in amps.

The short circuit protection components rely on this mechanism. The SCR has its cathode tied to the common connection of the four 0.1Ω sensing resistors while its gate is connected to the emitter of Q3 via the 1.5kΩ resistor. Thus the gate of the SCR senses the voltage across one of the 0.1Ω resistors and thereby monitors the total load current from the supply.

The voltage at the gate of the SCR is reduced slightly by dint of the 3.3kΩ resistor connected to the 0V line. A 0.1μF capacitor is also connected to the gate to remove any small transient pulses which might otherwise trigger the SCR into conduction.

Once the current through the monitored 0.1Ω resistor exceeds seven amps or so the voltage at the gate of the SCR is enough to trigger it into conduction. This supplies a bias current to the base of Q7 which also turns on and effectively shorts the collector of Q1 to the positive line. This means that the base voltage to Q2 via the 3.3kΩ resistor is shunted away. Thus Q2 and the associated transistors, Q3 to Q6, are turned off.

Thus the output current is very suddenly reduced to zero in the event of

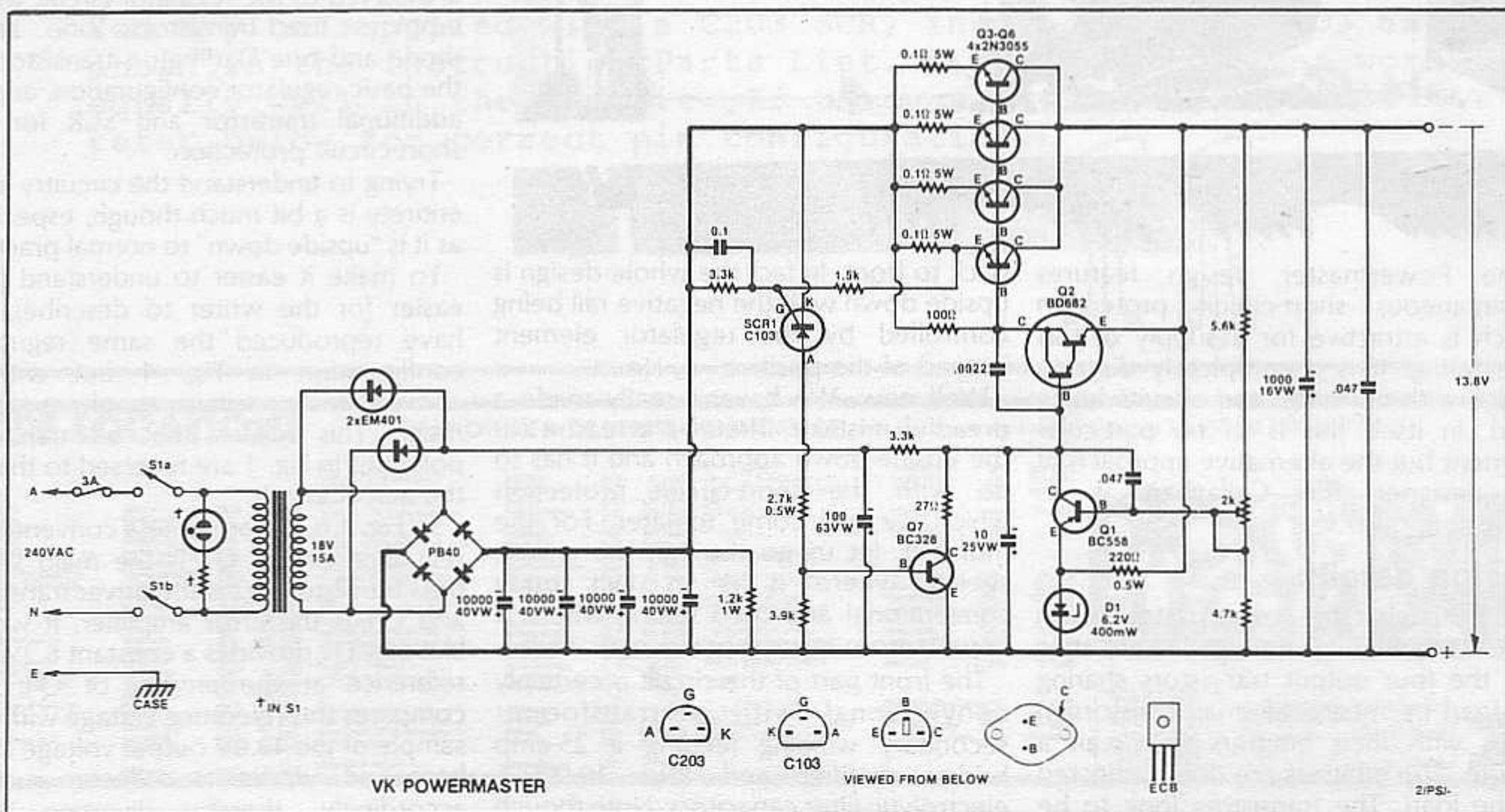

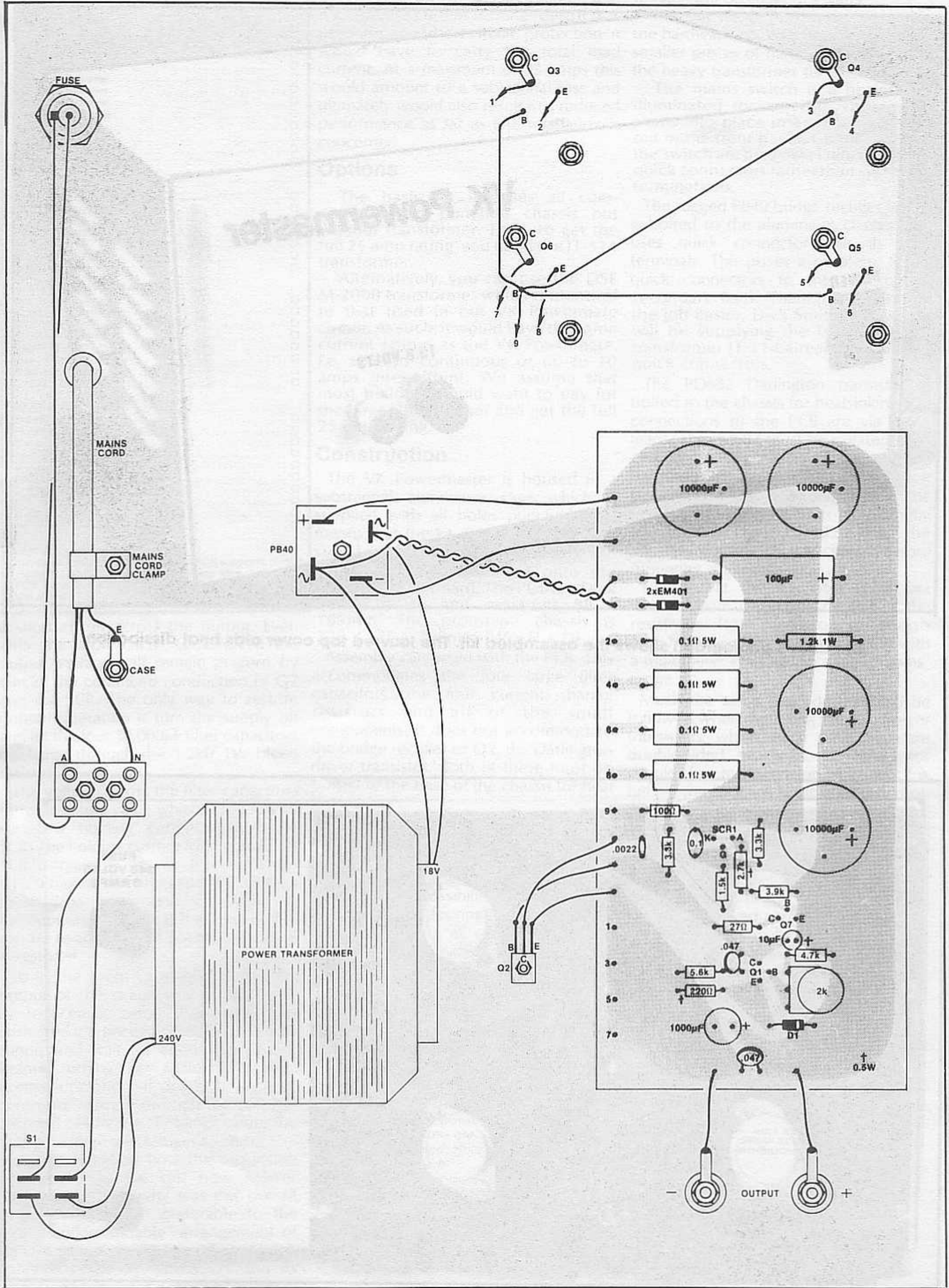

PCB Component Overlay



The above photograph shows the assembled kit. The louvred top cover aids heat dissipation.

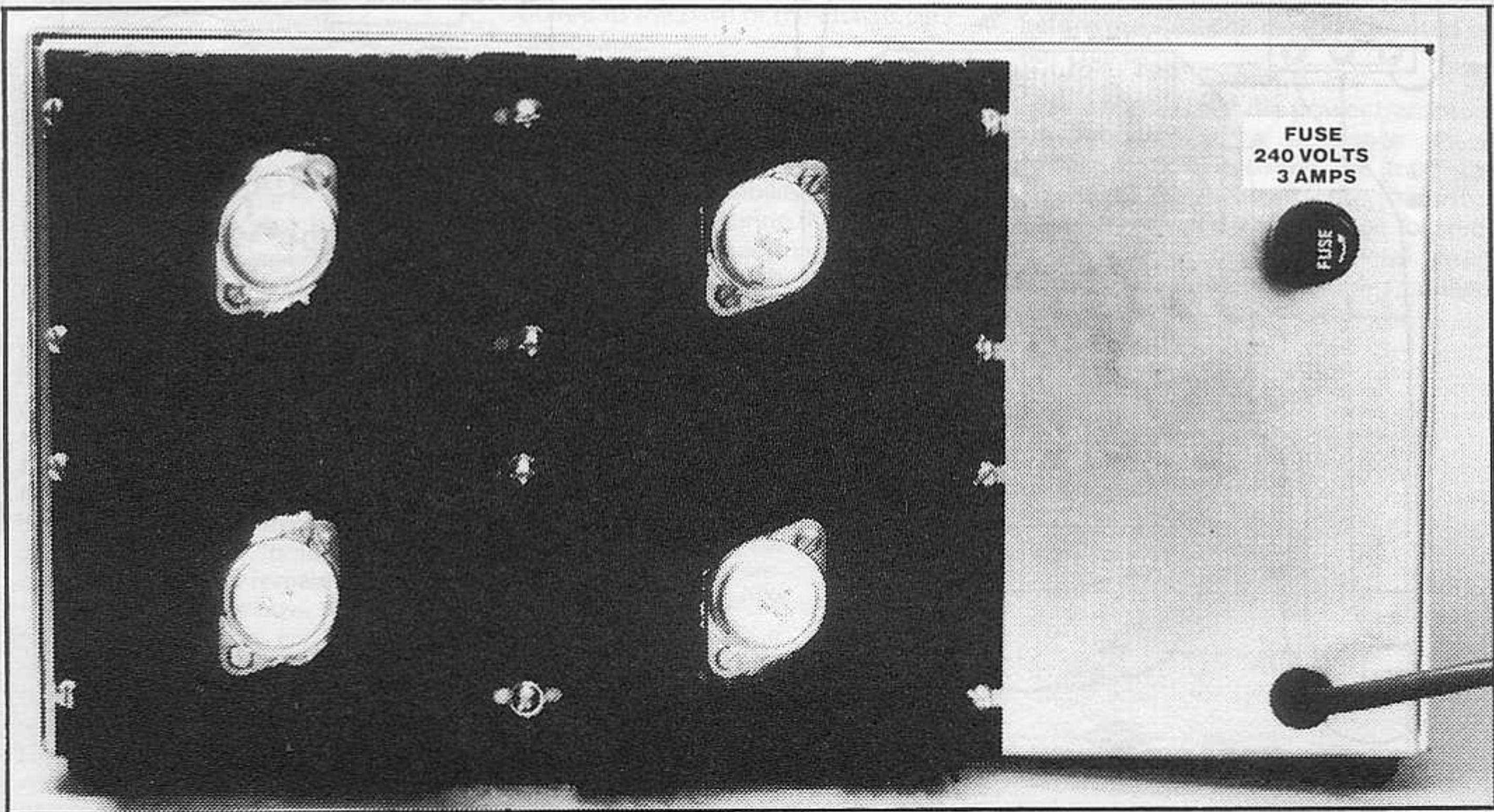

A view of the back panel showing the output transistors mounted on substantial heatsinks.

PARTS LIST

RESISTOR PACK

27R 1/4W Resistor	<input type="checkbox"/>
100R 1/4W Resistor	<input type="checkbox"/>
1.5K 1/4W Resistor	<input type="checkbox"/>
3.3K 1/4W Resistor	<input type="checkbox"/>
3.9K 1/4W Resistor	<input type="checkbox"/>
4.7K 1/4W Resistor	<input type="checkbox"/>
5.6K 1/4W Resistor	<input type="checkbox"/>
220R 1/2W Resistor	<input type="checkbox"/>
2.7K 1/2W Resistor	<input type="checkbox"/>
1.2K 1W Resistor	<input type="checkbox"/>
0.1R 5W Resistor	<input type="checkbox"/>
2K Trimpot (Large)	<input type="checkbox"/>

CAPACITOR PACK

0.0022uF Greencap	<input type="checkbox"/>
0.1uF Greencap	<input type="checkbox"/>
0.047uF Ceramic	<input type="checkbox"/>
100uF 63V RT	<input type="checkbox"/>
10uF 25V RB	<input type="checkbox"/>
1000uF 16V RB	<input type="checkbox"/>
10000uF 40V RB	<input type="checkbox"/>

SEMICONDUCTOR PACK

BC558 Transistor	<input type="checkbox"/>
BD682 Transistor	<input type="checkbox"/>
2N3055 Transistor	<input type="checkbox"/>
BC328 Transistor	<input type="checkbox"/>
IN4002/EM401 Diode	<input type="checkbox"/>
PB40/FPI4040 Bridge	<input type="checkbox"/>
6.2V 1W Zener Diode	<input type="checkbox"/>
C103B / C203B SCR	<input type="checkbox"/>

HARDWARE PACK

Rubber Feet (Large)	<input type="checkbox"/>
Illuminated Mains Switch	<input type="checkbox"/>
Black and Red Terminals	<input type="checkbox"/>
Fuse and Fuseholder	<input type="checkbox"/>
Transistor Mounting Hardware	<input type="checkbox"/>
Cable Clamp and Ties	<input type="checkbox"/>
3-Way Connector Block	<input type="checkbox"/>
Grommet	<input type="checkbox"/>
Lugs	<input type="checkbox"/>
Heatshrink Tubing	<input type="checkbox"/>

MISCELLANEOUS

Silicon grease, nuts and bolts, nylon PCB supports, plastic insulators to suit connectors, hook-up wire, autocable, PCB, case, heatsinks, main plug and cable, front panel, and solder.

a short circuit across the output. Even after the short circuit is removed the output voltage will remain at zero by dint of the continued conduction of Q7 and the SCR. The only way to restore normal operation is turn the supply off and let the four 10,000µF filter capacitors discharge through the 1.2kΩ 1W bleed resistor.

The voltage across the filter capacitors must drop to a value which is too low to sustain a "holding" current through the SCR. The holding current for a type C103 SCR is typically only a few milliamps which means that the capacitor voltage must drop to around five volts or thereabouts. Once that happens power can be re-applied and normal operation is restored.

So in the event of a short circuit the output of the circuit will automatically be reduced to zero. After the fault is corrected it is necessary to switch off the supply and wait for about 60 seconds before turning on again to restore normal operation. If power is restored before the current through the SCR has dropped below the "holding" value, the output voltage will remain at zero.

Having described how the protection circuitry works we can now answer another question: why was this overall circuit configuration preferable to the more "understandable" arrangement of Fig. 1? After all, an SCR could have been connected directly across Q1 and its gate used to monitor a sensing resistor in the negative supply line (of Fig. 1).

The question almost answers itself. The Powermaster protection circuit avoids

the need for an extra sensing resistor and its attendant power loss. Remember that if a separate current sensing resistor was used for the short-circuit protection it would have to carry the total load current. At a maximum of 25 amps this would amount to a substantial loss and ultimately would also result in a reduced performance as far as line regulation is concerned.

Options

The basic kit includes all components and punched chassis but without transformer. Then, to get the full 25 amp rating, you need the JT-314 transformer.

Alternatively, you can use the DSE M-2000 transformer which is identical to that used in our VK Powermate circuit. As such, it would have the same current ratings as the VK Powermate, i.e. 6 amps continuous or up to 10 amps intermittent. We assume that most builders would want to pay for the larger transformer and get the full 25 amp rating.

Construction

The VK Powermaster is housed in a substantial aluminium case which is supplied with all holes punched. This means that the kit construction is just a simple assembly job after the components are soldered onto the printed circuit board. The PCB is a Dick Smith design and measures 88 x 189mm. The prototype chassis is 275 x 155 x 200mm (W x H x D).

Assembly can begin with the PCB. This accommodates the four large filter capacitors, the four current sharing resistors and all of the small components. It does not accommodate the bridge rectifier or Q2, the Darlington driver transistor. Both of these must be bolted to the base of the chassis for heat dissipation.

Assembly of the PCB requires little comment except to note that the current sharing resistors should be stood slightly away from the surface of the board. This is to avoid the possibility of the resistors charring or discolouring the board when they are running at maximum power. Maximum power will be when the unit is

delivering 25 amps in which case each resistor will dissipate 3.9 watts.

Now put the PCB aside and assemble the hardware into the chassis. Install the smaller pieces of hardware first, leaving the heavy transformer till last.

The mains switch is a heavy-duty illuminated rocker type. This simply snaps into place in a rectangular cut-out in the front panel. Connections to the switch are made via Utilux push-on quick connectors rather than via solder terminations.

The rugged PB40 bridge rectifier which is bolted to the aluminium chassis also uses quick connectors for its four terminals. This poses a problem: fitting quick connectors to the transformer secondary lead. Thankfully, to make the job easier, Dick Smith Electronics will be supplying the larger 25-amp transformer JT-314 already fitted with quick connectors.

The BD682 Darlington transistor is bolted to the chassis for heatsinking and connections to the PCB are via flying leads. The BD682 must be isolated from chassis using TO-126 mounting hardware; ie, mica washer, insulating bush plus screw and nut. Smear a little heatsink compound onto the metal surface of the BD682 and the appropriate area of the chassis before mounting the transistor.

Check that the transistor is in fact isolated from chassis by measuring the resistance from collector to chassis (before any connections are made) with a multimeter switched to a high "Ohms" range.

Much the same procedure should be followed when mounting the four power transistors which each have separate double-sided heatsinks. The transistor should be mounted on the heatsink before the heatsink itself is mounted on the chassis.

Fig. 2 shows how the power transistors are mounted. If a resistance check reveals a short between the transistor case and the heatsink, the transistor must be removed and the fault located. In particular, check for metal swarf around the mounting holes drilled

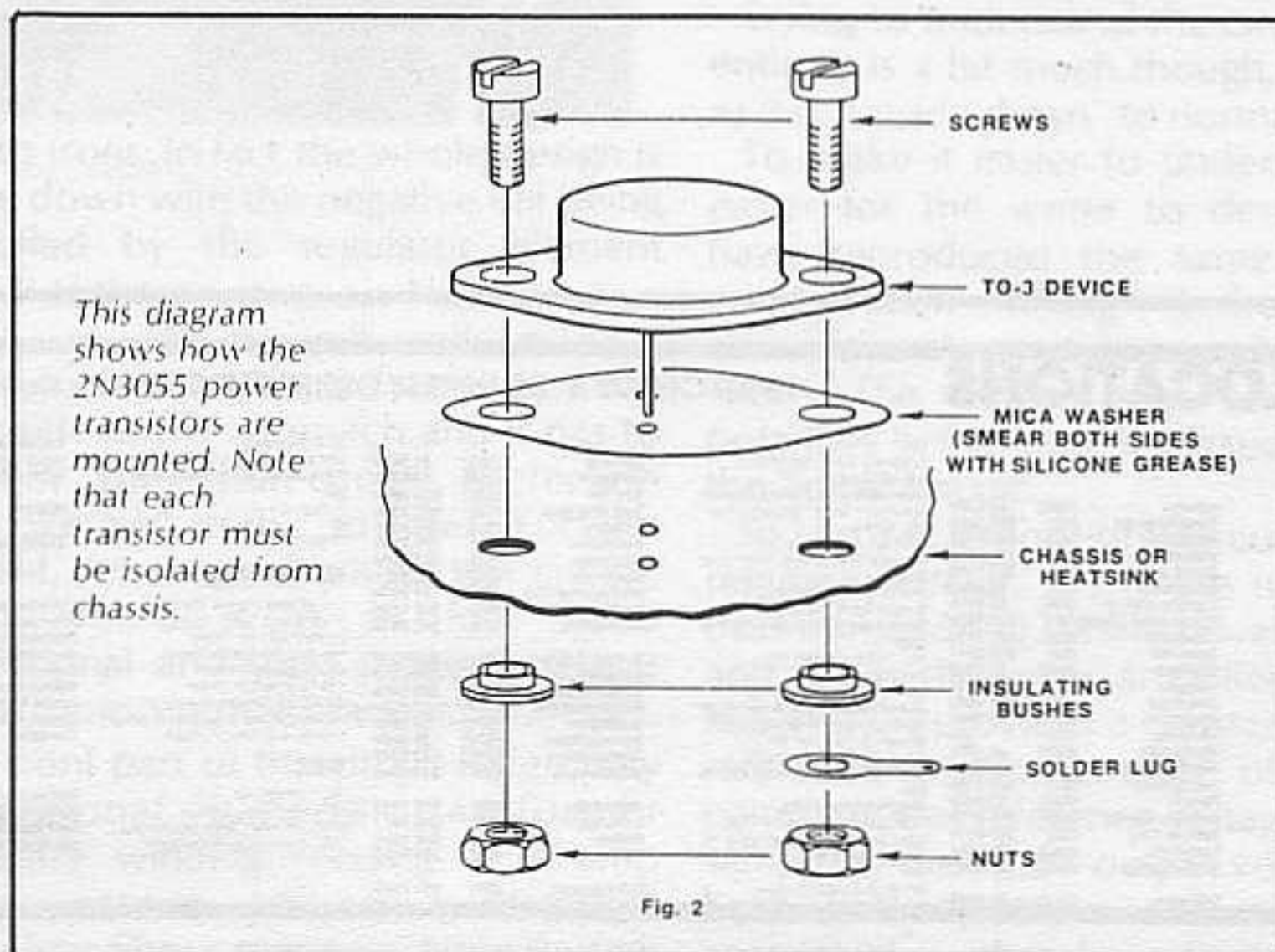

through the heatsinks. Please note that the mica washers supplied may be a little large to sit into the heatsink. If so, these can be trimmed to suit with a pair of scissors.

Heavy duty wiring

Rainbow cable or light duty hookup wire can be used for the connections to the following: between the PCB and BD682; the two wires between the transformer secondary and the PCB (to the two diodes), and the common base lead to the four output transistors. All other wiring, with the exception of the two short output leads from the PCB, must use heavy duty 32 x 0.2mm stranded hookup wire rated at 10A.

The two short output leads to the front panel terminals have to carry currents of up to 25 amps so they should use autocables.

To simplify the wiring procedure it is probably best to attach all the leads to the PCB and cut them to a suitable length before installing the PCB on its plastic supports. If you do it the other way around and attach all the leads to the power transistors and so on first, there will inevitably be quite a lot of flexing of the PCB connections during the wiring procedure with the result that some connections may break.

The connections to the four power transistors are made via four large diameter cutouts in the rear of the chassis.

All the wiring should be bound into neat cable forms to make the job look workmanlike and also to simplify any troubleshooting which may be necessary in the event of a fault.

Take care to make sure the mains wiring is safe. The mains cord passes through a grommeted hole in the rear of the chassis and is anchored with a cord

clamp. Terminate the mains active (brown) and neutral (blue) leads to the insulated terminal block and solder the earth lead (green yellow) to a solder lug bolted to chassis near the transformer. By the way, all screws and nuts should have shakeproof washers.

When wiring the mains fuseholder make sure you follow the wiring diagram and connect the incoming active lead from the terminal strip to the end terminal on the fuseholder. This reduces the possibility of shock when you are changing a live fuse (if you have not had the sense to unplug the unit from the mains). When the fuseholder wiring is complete, a length of heatshrink tubing should be slipped over it to shroud the mains terminations.

When the connections are made to the power switch, the quick connect terminals should also have plastic boots to shroud them and prevent accidental contact. These are not shown in the photograph of the prototype but should be fitted nevertheless.

Testing

When construction is complete, check all wiring carefully. Check that the complete circuit is isolated from chassis, apart from the mains earth connection.

Now apply power and with no load connected, set the trimpot to give 13.8V DC at the output. Ideally then, the regulation performance should be checked using a dummy load but that is not going to be easy. For a steady state test the required 0.55Ω resistor has to dissipate 345 watts when passing 25 amps.

If you are really keen to check the regulation one method would be to make up a 0.6Ω resistor using six

0.1Ω 5W resistors in series. Such a dummy load would only have a steady-state rating of 30 watts so it could only be used for a brief test lasting for a few seconds. If you do make this test the output voltage of the supply should not fall by more than 200mV between the loaded and unloaded conditions.

Such a test is likely to be more valid than one performed with a transmitter as a load. This is because your multimeter is likely to be upset by the transmitter signal.

In this regard, analog meters are usually less effected than digital types. We have found a digital meter to have an error of 1V during transmit, a cheap analog to have an error of 0.5V (probably due to a rectification effect of the protection diodes) and an expensive analog type to have no error.

Finding out whether your meter is likely to be affected is easy. Just short the meter leads and transmit. Any reading on the meter is obviously an induced error.

You can also check the operation of the short-circuit protection circuitry. Just short the output and check that the output does immediately go to zero and stays off until the mains is removed and then restored, one minute later. Incidentally, if the above load regulation test indicates that the SCR is too sensitive to allow a 25 amp current to be delivered, the sensitivity can be reduced by reducing the value of the 3.3kΩ resistor associated with the SCR.

During normal operation the output transistors will become very hot if high currents are being delivered. The supply is rated to deliver up to 14 amps continuously or up to 25 amps on an intermittent basis, for transmitter use. ☺

Notes & Errata

Constructors please note:

You may be supplied with a C203 SCR, instead of the C103 as shown in the instruction Parts List. Both these devices work equally well in the circuit. If using the C203 SCR, please refer below for correct pin configuration.

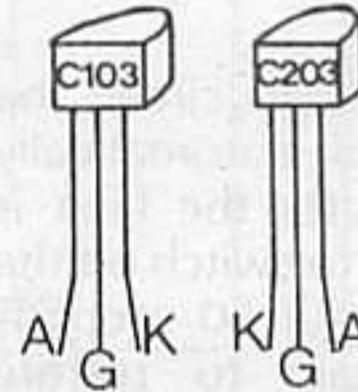

STORE LOCATIONS

HEAD OFFICE & DS XPRESS ORDER SERVICE P.O. Box 321, North Ryde, N.S.W. 2113. Tel: (02) 888 3200 AUSTRALIA.

Australia

Swift & Young St
150 Wattle Lane
Shop 1, 60-75 Main St
613 Princess Hwy
531 Princes Rd
Dundas & Adelaide St
531 Princes Rd
Campbelltown Mall Queen St
Shop 235, Archer St Entrance
147 Hume Hwy
156 Pacific Hwy
315 Mann St
4 Florence St
Elizabeth Dr & Bathurst St
450 High Street
621-627 The Kingsway
173 Marlboro Rd, Tynes Hill
Lane Cove & Waterloo Rd
George & Smith St
The Gateway High & Fern St
818 George St
125 York St
Heard's Bldg, Brisbane St
253 Kersh St
ACT
96 Castlere St

Abury (062) 21 8399
Bantolow St (02) 307 4668
Blacktown (02) 671 7722
Bidehurst (02) 546 7744
Bond Junction (02) 381 1444
Brookvale (02) 93 0441
Campbelltown (046) 21 2199
Cherrybrook (02) 411 1955
Chullora (02) 642 8922
Coffs Hill (02) 428 5311
Gosford (043) 25 0235
Hornsby (02) 477 6633
Liverpool (02) 600 9688
Maitland (049) 33 7866
Miranda (02) TBA
Newcastle (049) 61 1896
North Ryde (02) 88 3655
Parramatta (02) 699 2188
Penrith (047) 32 3400
Ragley Square (02) 211 3777
Sydney City (02) 267 9111
Tombong (047) 66 1211
Wollongong (042) 28 3800
Fremantle (087) 80 4944

WA

Dundas Rd & Webster St
140 McCree St
Shop 46, Box 48, Central Mall St
Northam Rd & Nelson Hwy
200 Sydney St
1150 Mt Alexander Rd
Nelson Hwy & Top Smith Ave
Shop 9, 110 High St
291-293 Elizabeth St
9 Sage Rd & The Boulevard
Springvale & Dandenong Tce
QLD
151-152 Elizabeth St
146 Logan Rd
Gympie & Hamilton Rd
Queen Elizabeth Dr & Bernard St
Gold Coast Hwy & Welch St
Bowen & Turner St
Kings Rd & Woodcock St
City Pacific Hwy & Kingston Rd
SA
Wright & Maker St
Main South & Flagstaff Tce
Main North Rd & Durrington St
24 Park Terrace
W.A.
Wharf St & Albany Hwy

Ballarat (053) 31 5433
Bendigo (054) 43 0388
Box Hill (03) 890 0699
East Brighton (03) 592 2366
Colburn (03) 383 4455
Essendon (03) 379 7444
Frankston (03) 783 9144
Geelong (052) 43 8522
Melbourne City (03) 67 9634
Richmond (03) 428 1614
Springvale (03) 547 0522
Brisbane City (07) 229 9377
Bundoora (07) 391 6232
Chermside (07) 359 6255
Southampton (079) 27 9644
Southport (075) 32 9663
Toowoomba (076) 38 4300
Townsville (077) 72 5722
Underwood (07) 341 0644

56 Adelaide St
Wharf St & Robinson Ave
Paine Square *25 Wharf St
IAS
25 Barkack St
NT
17 Stuart Hwy
New Zealand
City Harbour Road & Park Tce
1705 Great North Road
25 East Tamaki Road
4th & Commerce Street
400 Angelsea Street
150 Teahana Street
440 Cuba Street Auckland
Victoria Street & Seely Avenue
Worse & Stafford Streets
USA
390 Convention Ave
2474 Shattuck Avenue
2900 Stevens Creek Boulevard
1830 Westwood Boulevard

Fremantle (08) 338 9733
North Perth (09) 328 4944
Perth City (09) 481 3261
Hobart (002) 31 0800
Stuart Park (089) 61 1977
Newmarket (09) 393 192
Avondale (09) 88 6696
Papakatoe (09) 278 2355
Auckland City (07) 38 9974
Hamilton (071) 39 4490
Wellington (04) 73 9858
Lower Hut (04) 66 2022
Christchurch (03) 50 405
Dunedin (024) 74 1096



PTV LTD

Items available to approved personal applicants through

AGC

bonicard welcome here

MasterCard

VISA

Redwood City, Calif (415) 368 8444
Bensley, Calif (415) 486 0755
San Jose, Calif (408) 241 2366
Los Angeles, Calif (213) 474 0626