

DUAL CONTROL ANTENNA ROTOR

MODEL

KR-5400 A KR-5600 A

INSTRUCTION MANUAL

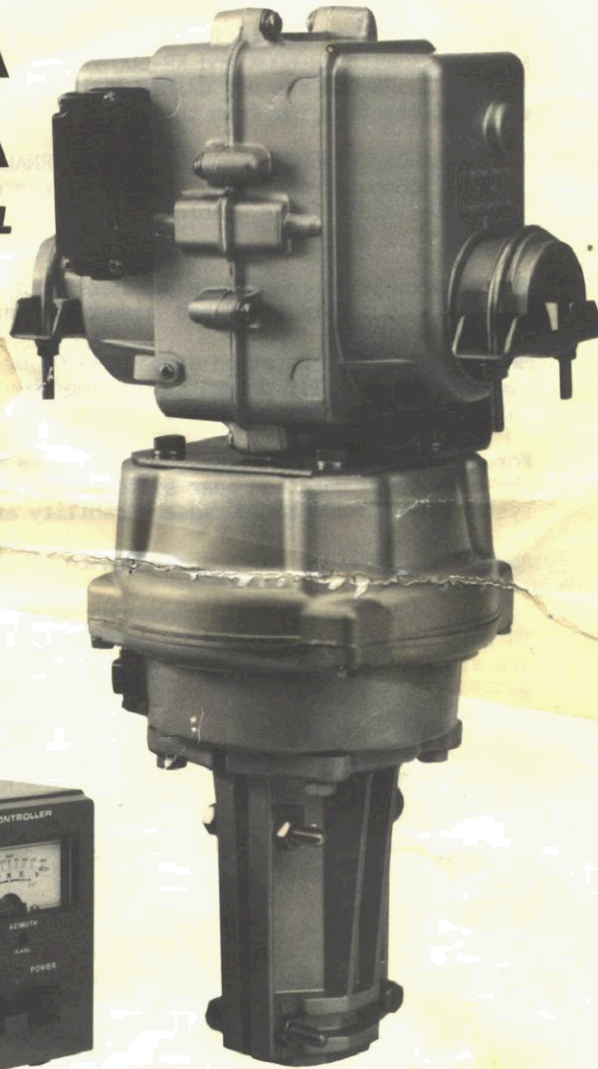

 **KENPRO**

Downloaded by

Amateur Radio Directory

DUAL CONTROL ANTENNA ROTOR

MODEL:KR-5400A/5600A

* FEATURES

1. The KR-5400A/5600A is designed to control the AZIMUTH using rotor unit KR-400 or the KR-600X and the ELEVATION using rotor unit KR-500 with one control box.
2. Model:KR-5400A is consisting of KR-400 and KR-500 rotor units, and Model : KR5600A is with KR-600X and KR-500 rotor units, but the rotor unit of ordinary KR-600RC or KR-600 are not usable with the control box of the KR-600A, since it uses different wiring from the control box of the KR-600RC and KR-600 units.
3. The KR-5400A/KR-5600A are provided EXTERNAL CONTROL TERMINAL(DIN connector) for using of computer operation, and it offers great convenience for satellite tracking. Besides, it is usable for digital indication of angular or preset control.
4. The rotor unit is housed in weathersealed aluminum die-cast housing with melamine-resin coating, and has superior durability.
5. Mechanical End-of-Rotation stop (KR-400) or Electrical/Mechanical End-of-Rotation stop (KR-600X), prevents worrying about the coaxial cable being wrapped or cut.
6. For the prevention of noise,, molded gears and precision cut gears are used in the high speed rotation gear system, and the gear in the low speed rotation system is tempered to increase durability and strong.
7. As the main voltage is stepped down to 24VAC, it provides safe operation.
8. The Sandwich type mast clamp and mast gauge on the top and bottom of the AZIMUTH rotor eliminates, any aligning problems of the antenna or rotor installation are eliminated.

* BEFORE INSTALLATION

Please be sure that following articles should be contained in a packing carton after unpacked.

AZIMUTH rotor unit(KR-400 or KR-600X).....	1
ELEVATION rotor unit (KR-500).....	1
Control Box	1
Mast Clamp(KC-038) for AZIMUTH.....	1
L Bracket for KR-500.....	1
Stud Bolt for KR-500.....	4
M8 - 16 Bolt for KR-400/600X & L bracket...4	
M8 - 25 Bolt for KR-400/600X & KC-038.....4	
M8 - 70 Bolt for KC-038.....	4
U Bolt for KR-500 & Boom.....	2
Boom Clamp for KR-500.....	2
φ6 Spring Washer.....	4
φ8 Spring Washer.....	20
φ6 Washer.....	4
φ8 Washer.....	4
M6 Nut for U Bolt.....	4
M8 Nut for KR-500 & L Bracket.....	8
Instruction Book.....	1

A part of stamped 'UP' on the top of the rotor units must be faced up, when install them to a tower or a supporting mast, otherwise damage may occur caused by water leakage.

Please do not over tighten the screws of the mast. It is enough support for a mast to tighten the clamp bolts and add 1 or 1½ revolution after spring washer comes flat.

It is not necessary to change the grease in the rotor unit. Molybdenum grease of the most excellent performance is used as lubrication.

Please do not run for hours continuously. Recommendable continuous run is not more than 5 minutes.

Please do not suddenly reverse the run during operation, as abnormal load is given to the inner mechanism and can result in damage.

*PERMISSIBLE ANTENNA SIZE

Wind load area be not more than 0.8M².(8.5 sq.ft.)
Estimated wind velocity is up to 30mph.

It is recommended to use with plenty of reserve capacity depending on the conditions of use.

Weight of the antenna should be balanced on either side of the boom at the mast-to-boom clamp. Unbalanced installation results in leverage force which strains the mast at the clamping point on the rotor. Greater care should be given especially in high wind area.

*INTERCONNECTION

- 1.Connect 6 conductor cable between the terminals of AZIMUTH rotor unit and terminal for AZIMUTH of the control box, and each wire must be connected between same numbers of the terminals on control and rotor as shown in Figure 3.
Same procedures are required in the ELEVATION rotor wiring.
- 2.Plug the line cord of the control box into an AC power outlet. Use the correct voltage your control box model.
- 3.Depress the power switch to ON and pilot lamp in the meter units of the control box will light and both indication needles move and stop at the direction the rotor was set at the factory.
- 4.Depress LEFT(CCW) switch and AZIMUTH rotor runs to the left (looking from top).
Again, depress the LEFT switch until the indication needle stops automatically, and be sure that the needle exactly reads 'N' of the left. If not, adjust the needle by 'O' ADJ. screw located under the meter unit.
- 5.Put a 'MARK' on the top of the rotor unit to know rotation of the rotor unit.
- 6.Depress RIGHT(CW) switch and rotor runs to the Right (looking from top), and release the switch when the MARK rotates full 360° clockwise, and be sure that the needle exactly reads 'N' of the right. If not, adjust the needle by FULL SCALE ADJ. VR. located rear panel.
- 7.Again, depress LEFT switch and rotates the rotor unit full 360° counter clockwise until indication needle exactly reads 'N' of the left.
- 8.Depress DOWN switch and ELEVATION rotor unit rotates, and when the hallmark located

on the rotation part of the rotor unit comes to '0' point, release the switch. At the time, be sure that the indication needle also exactly reads '0' in the meter. If not; adjust the needle by ADJ. screw located under the meter unit.

- Depress UP switch until the hallmark comes to 180° point, and be sure that the indication needle exactly reads 180° in the meter unit. If not, adjust the needle by FULL SCALE ADJ. VR. in the rear panel. Again, depress DOWN switch until the indication needle comes to '0' point of the left in the meter unit.

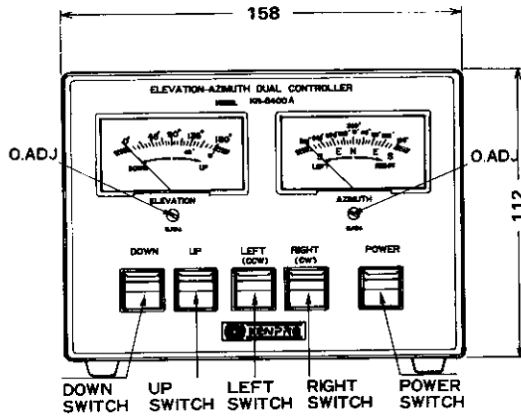

Fig 1

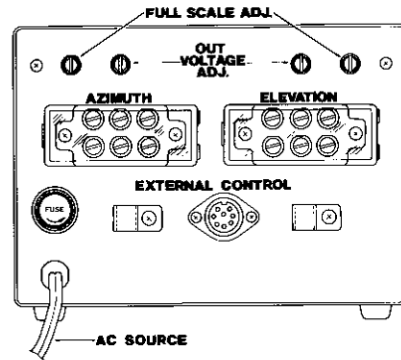

Fig 2

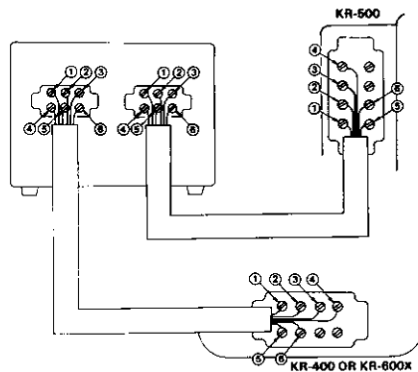

Fig 3

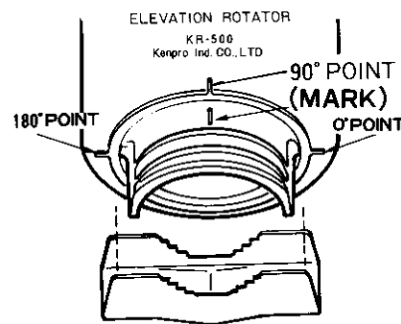

Fig 4

※ INSTALLATION

- Provisionally attach the mast clamp to the AZIMUTH rotor unit. Please make use of the mast gauge which is shown on the both surface of the rotor unit to install a mast to center.
(Put inner surface of the clamp on the mast gauge in accordance with your desired mast size.)
- CAREFULLY INSTALL THE ROTOR UNIT NOT UP SIDE DOWN.
- Fix the 'L' bracket for the ELEVATION rotor unit on the top of AZIMUTH rotor unit by using M8-16 bolts with $\varnothing 8$ spring washers, and attach the stud bolts to the side of ELEVATION rotor unit with $\varnothing 8$ spring washer and fix to the 'L' bracket.
(Attached sticker on the side of ELEVATION rotor unit is the NOTE for using option mast clamp.)

4. Install the mounted rotor units to a supporting mast with using the mast clamp which is provisionally attached to bottom side of AZIMUTH rotor unit, and fix the rotator units to the supporting mast. At this time, it must be adjusted to face the antenna beam to the NORTH supposing an antenna has been installed. (Please refer to Fig.6)
5. Insert a boom mast to the ELEVATION rotor unit and fix it with 'U' bolts.
6. Antenna beam must be faced horizontally in the antenna installation.
7. Again, depress the LEFT(CCW) switch and RIGHT(CW) switch alternately, and be sure that if the rotor direction should coincide with the meter indication. In the same way, be sure of ELEVATION rotor.
8. Except in the above mentioned installation, other installation as shown in Figure 8. Require the use of the boom mast clamp for ELEVATION rotor unit.

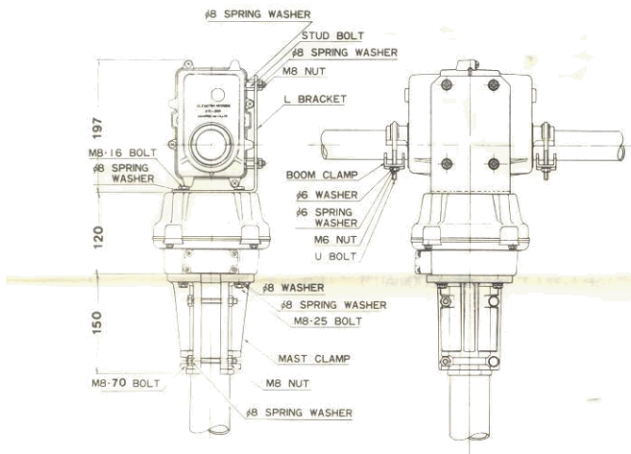

Fig 5

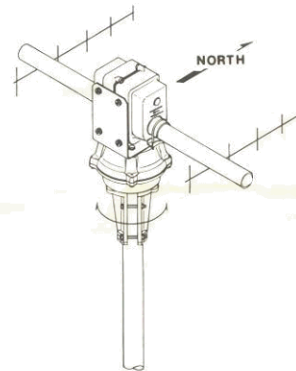

Fig 6

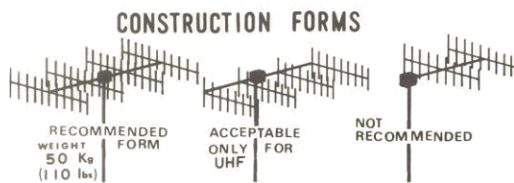

Fig 7

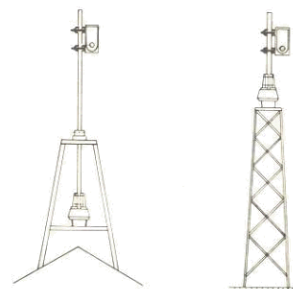

Fig 8

* TERMINAL CONNECTION

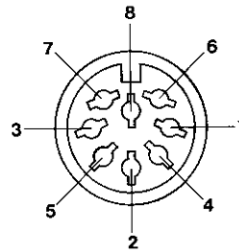

Table:1

FUNCTIONS	TERM. NO.	CONTENTS
Horizontal Rotation Angular Detection Terminal	6	Indicated rotation angular is converted into voltage. (Output Impedance 10 Kohms)
Vertical Rotation Angular Detection Terminal	1	Indicated elevation angular is converted into voltage. (Output Impedance 10 Kohms)
LEFT Direction Control Terminal	4	When connect with terminal No.8, the rotor rotates to counter clockwise.
RIGHT Direction Control Terminal	2	When connect with terminal No.8, the rotor rotates to clockwise.
DOWN Direction Control Terminal	5	When connect with terminal No.8, the rotor rotates to down.
UP Direction Control Terminal	3	When connect with terminal No.8, the rotor rotates to up.
Output Voltage : approx. 13 - 6v Output Current : less than 200mA	7	This voltage is varied depending on the output current. Available utilized voltage is approx. 6v at 200mA
Earth Terminal	8	

1. Terminal No.6 and No.1.

This terminal enables to detect horizontal angular in 0° to 360° by output voltage. The output voltage is 0v at full counter clockwise rotation, and max. output voltage becomes 4.5v at full clockwise rotation.

Also, the max output voltage is able to vary down to approx. till 2v at will by using OUT VOLTAGE ADJ. VR for AZIMUTH on the rear panel.

For example, if the max. output voltage is adjusted to 3.6v, 1° of horizontal angular is detected as 0.01v.

In the same manner, on the terminal No.1, if adjust output voltage to 3.6v at full 180° vertical rotation, 1° of elevation angular is detected as 0.02v.

2. Terminal No.2,3,4, and 5.

Each terminal is a rotation control terminal by combination with terminal No.8.

3. Terminal No.7.

This terminal presents the voltage, but it does not stable voltage, besides current capacity is small, therefore, it is necessary to consider in the utilization.

¶ CAUTION

0v at full counter clockwise supplies not exactly 0v due to existence of inner resistance in a cable and in a volume control, therefore, in case of computer control, it is recommended to make program in consideration of the allowance.

If remove a control cable from terminal No.6 of the rotor unit and connect it to the terminal No.7, the thermostat is released and not protected from overheating. Therefore, greate care is necessary to this usage.

* TROUBLE SHOOTING

1. Hindrance : No moving indication needle in the meter unit.
Cause : Disconnective wiring terminals No.1 or No.2.
2. Hindrance : Indication needle moves full scale, but not return.
Cause : Terminal No.3. is disconnected
3. Hindrance : Occurs unstable moving of the indication needle.
Cause : Difective VR in the rotor unit.
4. Hindrance : No rotation.
Cause : a) Terminal No.4,5 and 6 are disconnected.
b) Difective Gear.
5. Checking voltage between each terminals of the control box.
Disconnect cable from the control box.
 - a) Power switch to ON.
1 to 3 : approx. 6VDC
 - b) LEFT switch to ON.(AZIMUTH only)
4 to 6 & 5 to 6 : approx. 30VAC (Model:KR-5400A)
4 to 6 : approx. 30VAC (Model:KR-5600A)
5 to 6 : 0 (Model:KR-5600A)
 - c) RIGHT switch to ON.(AZIMUTH only)
4 to 6 & 5 to 6 : approx. 30VAC (Model:KR-5400A)
4 to 6 : 0 (Model:KR-5600A)
5 to 6 : approx. 30VAC (Model:KR-5600A)
 - d) DOWN switch to ON.(ELEVATION only)
4 to 6 & 5 to 6 : approx. 30VAC
 - e) UP swithc to ON.(ELEVATION only)
4 to 6 & 5 to 6 : approx. 30VAC
6. Checking resistance between each terminal of the rotor unit.
Disconnect cable from the control box.
 - a) KR-400 & KR-500
1 to 2 : 0 - 500 ohms (Depending on rotor position)
2 to 3 : - do -
4 to 5 : 8 ohms
4 to 6 : 4 ohms
5 to 6 : 4 ohms
 - b) KR-600X
5 to 6 & 4 to 6 : 10 ohms
4 to 5 : 20 ohms
4 to 5 & 4 to 6 : Infiniteness (At full CCW rotation stop)
4 to 5 & 5 to 6 : Infiniteness (At full CW rotation stop)

* SPECIFICATIONS

A. Model:KR-5400A

§ AZIMUTH (KR-400)

Rotation Torque : 600 Kg.- Cm.(520 Lbs.- In.)
Stationary Brake Torque : 2000 Kg.- Cm.(1730 Lbs.- In.)
Vertical Load : 200 Kg. (440 Lbs.)
End-of-Rotation Stopper : Mechanical
Rotation Time : 60sec./50Hz, 50sec./60Hz
Thermostat is installed.

§ ELEVATION (KR-500)

Rotation Torque : 1000 Kg. Cm.(866 Lbs.-In.)
Stationary Brake Torque : 2000 Kg.- Cm.(1730 Lbs.- In.)
End-of-Rotation Stopper : Mechanical
Rotation : 0° to 180° (+5°/-0°)
Thermostat is installed.
Permissible Mast Size : Ø38 - Ø63
Permissible Boom Size : Ø32 - Ø43
Continuous Operation Time : Max. 5 Minutes
Antenna Wind Load Area : Less than 0.8M²
Control Cable : 6 Conductor
Input Voltage : AC 115/230V, 50Hz/60Hz
Motor (Rotor Unit) : AC24V
Meter Indication Difference: ±4°
Weight (Incl. Rotor & Clamps): 12 Kgs.

B. Model:KR-5600A

§ AZIMUTH (KR-600X)

Rotation Torque : 700 Kg.- Cm.(606 Lbs.-In.)
Stationary Brake Torque : 4000 Kg.- Cm.(3460 Lbs.- In.)
Vertical Load : 200 Kg. (440 Lbs.)
End-of-Rotation Stopper : Electrical/Mechanical
Rotation Time : 60sec./50Hz, 50sec./60Hz
Thermostat is installed.

§ ELEVATION (KR-500)

Rotation Torque : 1000 Kg.- Cm.(866 Lbs.- In.)
Stationary Brake Torque : 2000 Kg.- Cm.(1730 Lbs.- In.)
End-of-Rotation Stopper : Mechanical
Rotation : 0° - 180° (+5°/-0°)
Permissible Mast Size : Ø38 - Ø63
Permissible Boom Size : Ø32 - Ø43
Continuous Operation Time : Max. 5 Minutes
Antenna Wind Load Area : Less than 0.8M²
Control Cable : 6 Conductor
Input Voltage : AC 115/230V, 50Hz/60Hz
Motor (Rotor) : AC24V
Meter Indication Difference : ±4°
Weight (Incl. Rotor & Clamps): 12 Kgs.

† A ROTOR UNIT OF ORDINARY KR-600RC and KR-600 DOES NOT USE WITH THE CONTROL BOX OF MODEL:KR-5600.

P A R T S L I S T

¶ CONTROL BOX

- | | |
|---|--------------------------------|
| 1. Front Panel | 30. DIN Connector (Receptacle) |
| 2. Front Frame | 31. DIN Plug |
| 3. Rear Frame | 32,33. OUT VOLTAGE ADJ. VR |
| 4. Top Cover | |
| 5. Bottom Cover | |
| 6. AZIMUTH Meter | |
| 7. ELEVATION Meter | |
| 8. Transformer | |
| 9. Power Switch | |
| 10. LEFT (CCW) Switch | |
| 11. RIGHT (CW) Switch | |
| 12. DOWN Switch | |
| 13. UP Switch | |
| 14. Full Scale Adjusting VR. | |
| 15. VR. Bracket | |
| 16. AC Power Cord | |
| 17. Terminal Board | |
| 18. Terminal Cover | |
| 19. AC Power Cord Stopper | |
| 20. Grommet | |
| 21. Control Cable Holder | |
| 22. Fuse Holder | |
| 23. Fuse | |
| 24. Printed Board Assembly | |
| 25.26. Pilot Lamp | |
| 27.28. Lamp P.C. Board | |
| 29. Electrolytic Condenser
(2 pcs. used in KR-5400, but 1 pc. used
in KR-5600.) | |

¶ ELEVATION Rotor Unit (KR-500)

- | | |
|----------------------------------|---------------------------------|
| 1.2. Rotor Housing | 32. 'C' Ring |
| 3. Gear Mount Plate | 33.34. Ball Bearing Holder |
| 4. Gear Mount Support | 35. Rubber Terminal Sheet |
| 5. Gear Stud Sleeve | 36. Terminal Board |
| 6. Stud Support Sleeve | 37. Terminal Cover |
| 7.8. Gear Shaft | 38. Rubber Grommet |
| 9. Assmb. Gear | 39. Control Cable Holder |
| 10.11. Internal Gear | 40. Name Plate |
| 12. Plastic Motor Gear | 41,42. Gear Mount Screw |
| 13. Stud Support Sleeve | 43.44. Motor Mount Screw |
| 14. Gear Pot. Shaft | 45.46.47. Motor Holder Screw |
| 15. Plastic Pot. Gear | 48.49. Housing Mount Screw |
| 17. Potentiometer | 50.51. Housing Screw |
| 18. Insulator Sheet | 52. Terminal/Cable Holder Screw |
| 22. Pot. Divider Gear | 54.55. Terminal Cover Screw |
| 23. Gear Stopper Screw | 56. 'U' Bolt |
| 24. Gear/Motor Mount Plate | 57. Clamp |
| 25. AC 24V Motor | 61. Mast Clamp Stud Bolt |
| 26. Motor Mount Plate | |
| 27. Disc Brake/Pinion Motor Gear | |
| 28. Disc Pad | |
| 29. Boom Shaft Tube | |
| 30. Stopper Stud Pin | |
| 31. Assmb. Tube Gear | |

P A R T S L I S T

¶ AZIMUTH Rotor Unit (KR-400)

- | | |
|-------------------------------|-----------------------------------|
| 1. Gear Mount Plate | 34. Washer |
| 2. Gear Mount Support | 35. Washer |
| 3. Washer (Ø6) | 36. Motor Holder Screw |
| 4. Gear Mount Screw | 37. Disc Pad |
| 5. Insulator Sheet | 38. Brake Plate |
| 6. Potentiometer | 39. Washer |
| 10. Gear Pot Shaft | 40. Ø2.5 'E' Ring |
| 11. Pot. Divider Gear | 41. Case |
| 12. Gear Stopper Screw | 42. Gear Mount Plate Holder Screw |
| 13. Plastic Pot. Gear | 43. Washer |
| 14. 'E' Ring | 44. Ball Bearing |
| 15.16.21. Stud Support Sleeve | 45. Internal Gear |
| 17. Gear Shaft | 46. Rubber Terminal Sheet |
| 18. Gear | 47. Terminal |
| 19.20. Pinion/Gear Assmb. | 48. Terminal/Cable Holder Screw |
| 22. Gear/Motor Mount Plate | 49. Rotor Housing |
| 23. Revolution Stopper | 50. Housing |
| 24. Fixing Pin | 51. Washer |
| 25. Gear Pot. Shaft | 52. Housing Screw |
| 26. Plastic Gear | 53. Cable Holder |
| 29. AC 24V Motor | 54. Terminal Cover |
| 30. Motor Pinion | 55. Rubber Grommet |
| 31. Motor Mount Plate | 56. Washer |
| 32. Motor Mount Screw | 57. Terminal Cover Screw |
| 33. Washer | |

¶ AZIMUTH Rotor Unit (KR-600X)

- | | |
|------------------------------|--|
| 1. Gear Mount Plate Assmb. | 43. Washer |
| 2. Gear Mount Support | 46. Rubber Sheet |
| 3. Washer | 47. Terminal |
| 4. Gear Mount Screw | 48. Terminal/Cable Holder Screw |
| 5. Insulator Sheet | 49. Rotor Housing |
| 6. Potentiometer | 50. Housing |
| 7. Nut | 51. Washer |
| 8. Spring Washer | 52. Housing Screw |
| 9. Washer | 53. Cable Holder |
| 10. Gear Pot. Shaft | 54. Terminal Cover |
| 11. Pot. Divider Gear | 55. Rubber Grommet |
| 12. Gear Stopper Screw | 56. Spring Washer |
| 13. Plastic Pot. Gear | 57. Terminal Cover Screw |
| 14. 'E' Ring | 58. 59. Mast Clamp |
| 15.21. Stud Support Sleeve | 60. Washer |
| 16.17. Gear Shaft | 61. Spring Washer |
| 18. Gear | 62.63. Screw |
| 19.20. Pinion/Gear Assmb. | 64. Nut |
| 22. Gear/Motor Mount Assmb. | 65. Condenser Bracket |
| 29. Motor Assmb. | 66. Electrolytic Condenser (100mfd/60wVAC) |
| 34. Washer | 67. Screw M3 x 6 |
| 35.56. Washer | |
| 36. Screw for Motor Holder | |
| 37. Limit Switch | |
| 41. Case | |
| 42. Mount Plate Holder Screw | |

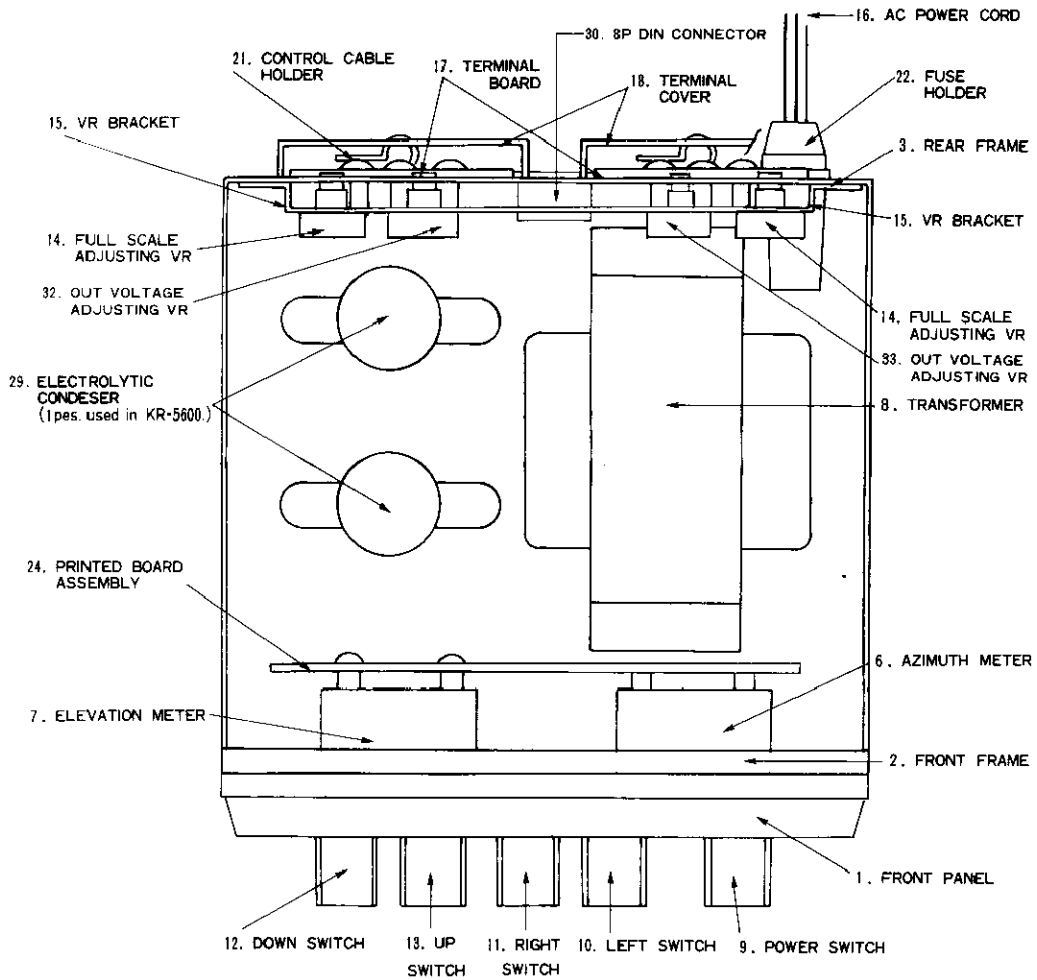

MODEL KR-600X ROTOR

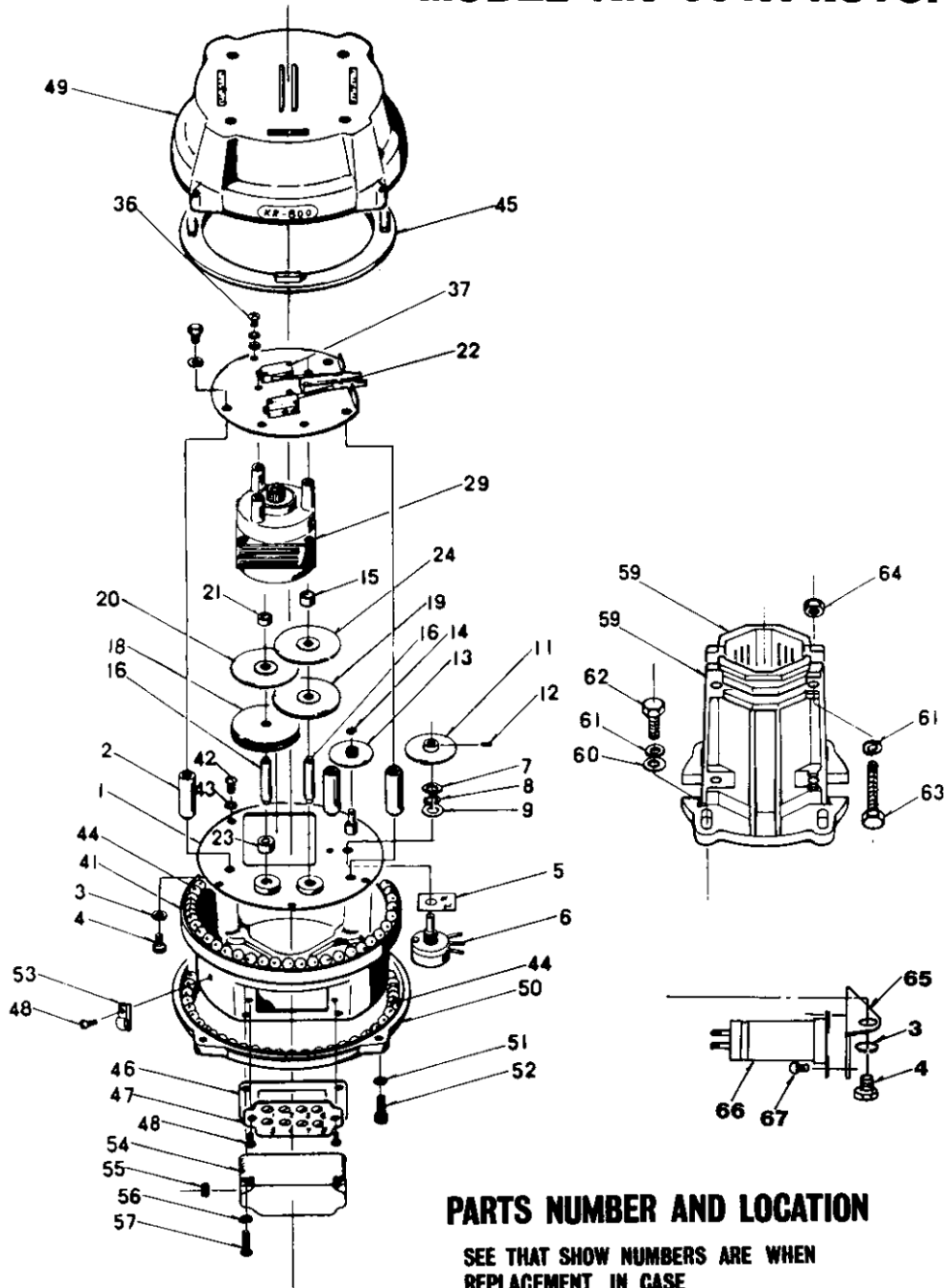

MODEL KR-500 ELEVATION ROTOR

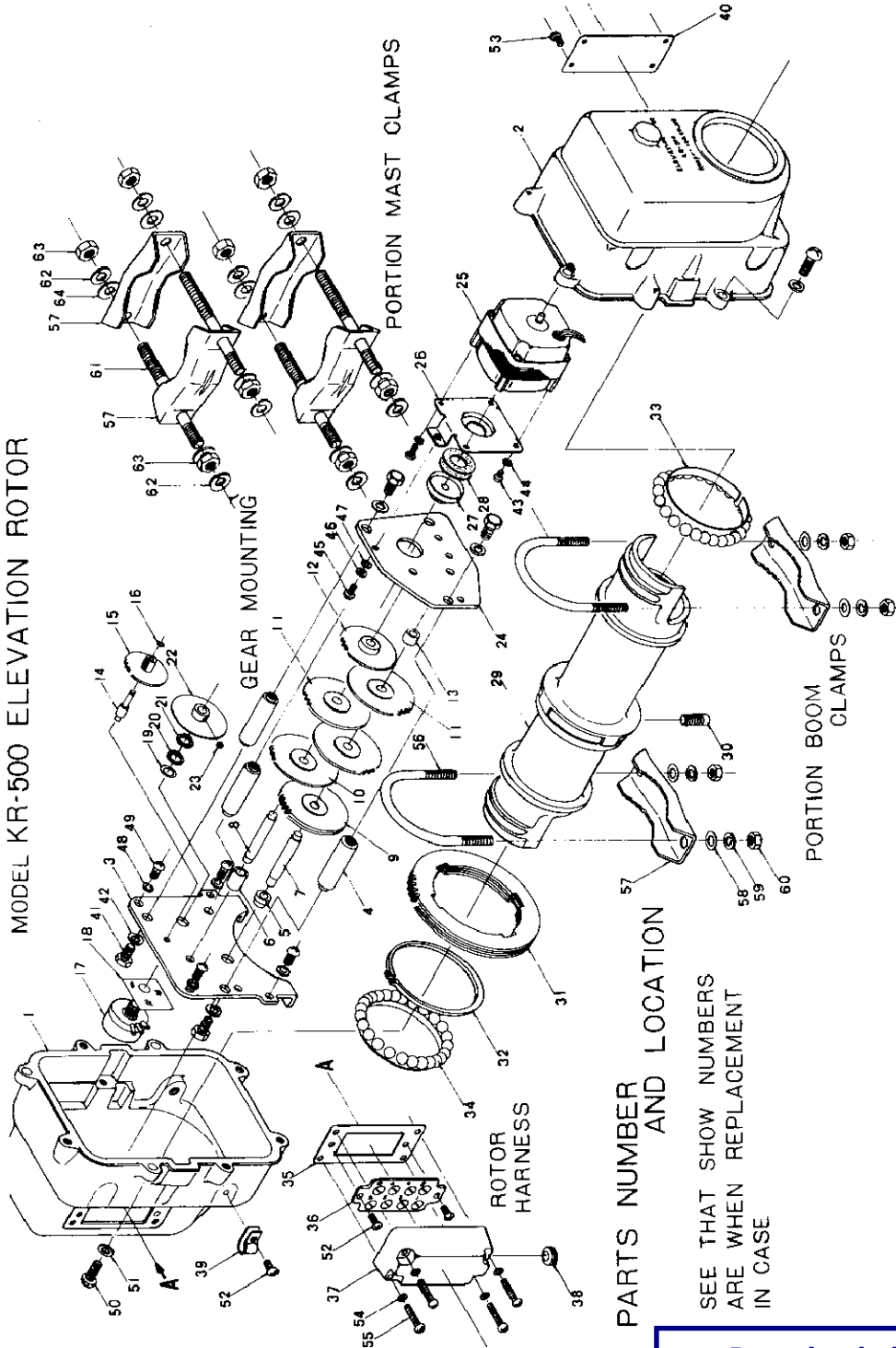

PARTS NUMBER AND LOCATION

SEE THAT SHOW NUMBERS ARE WHEN REPLACEMENT IN CASE

Downloaded by

 Amateur Radio Directory

KR-5400A

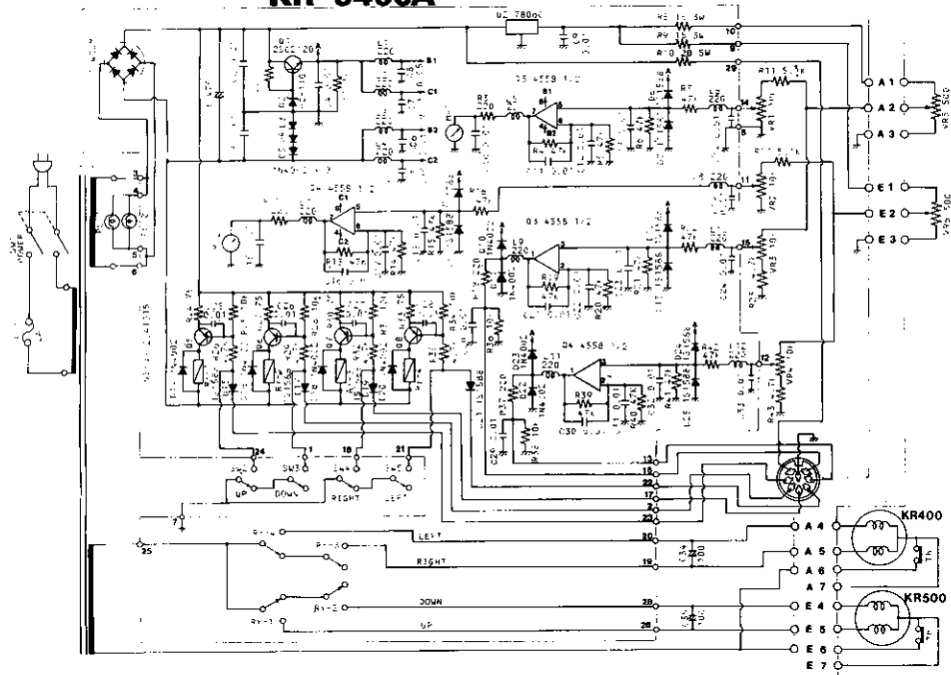

KR-5600A

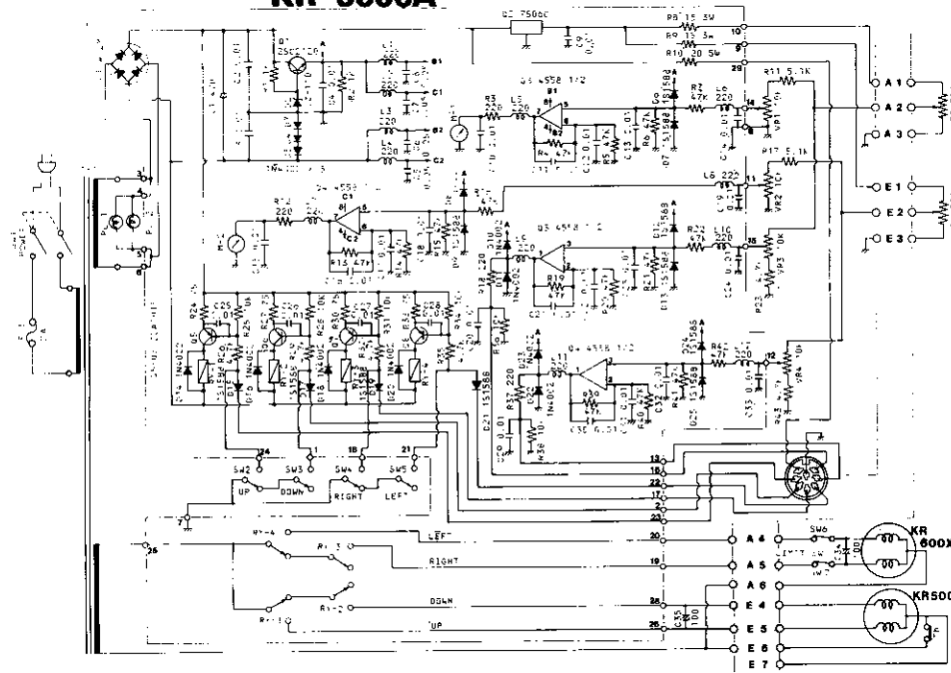

MANUFACTURER.

KENPRO INDUSTRIAL CO.,LTD.

TOYOMURA ELECTRONICS CO.,LTD.

2-7-9, Sotokanda, Chiyoda-ku, Tokyo, Japan.
TLX02223391 CQ TEC J FAX03-251-9705
