

**ANTENNAS  
MASTS and  
ACCESSORIES**



**South Midlands Communications**

The future never sounded so good

**Issue 2**

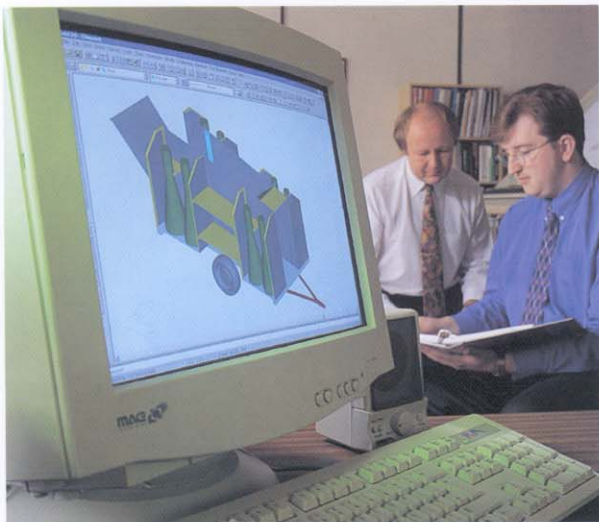



South Midlands Communications

## CONTENTS

- 1 Wideband HF Antennas
- 2 Rotatable Log Periodics and Verticals
- 3 HF Multi-Frequency Dipoles
- 4 MF and HF Antennas
- 5 Simple HF Antennas
- 6 HF Balun Transformers
- 7 Antenna Centre Junctions
- 8 Transmission Lines and Loads
- 9 Radial Earth Systems
- 10 Tactical Antennas
- 11 Tactical Masts
- 12 HF/VHF/UHF Mobile Antennas
- 13 UHF/VHF Antennas
- 14 Tubular Support Masts
- 15 Telescopic Masts/Towers
- 16 Lattice Towers and Masts
- 17 Mast Lighting
- 18 Tower Earthing Equipment
- 19 Antenna Rotators
- 20 Coaxial and Multicore Cables and Accessories
- 21 Coaxial Connectors
- 22 Mast and Antenna Hardware
- 23 RF Insulators
- 24 Steel and Copper Wires

## Overview

SMC was established in 1958 and initially specialised in support masts, towers and the manufacture of antennas. Today SMC is recognised as one of the most comprehensive and professional mobile communications companies in the UK covering the world market.

Between them the SMC group of companies can advise, design, supply and install practically every form of mobile communications, from simple but robust radio systems, masts and antennas to the most sophisticated communications equipment designed for the 21st Century.

## Masts

A full range of tubular support masts, for many applications from 6-30 m in aluminium, steel, and composite glass fibres, is designed and manufactured in house, with the added capability of customising to specific environments or applications.

## Antennas

SMC specialises in the manufacture of HF communication antennas including simple dipoles and multifrequency trapped dipoles, wide band, low and medium power antennas, and we have the flexibility to produce 'one offs' for specific requirements. A small range of VHF antennas is also available.

## Tactical/Transportable Antennas

For many years we have manufactured tactical and transportable military



antennas, starting with the very popular LW8 Tactical dipole weighing less than 1kg, to a range of wide band, directional, and omni-directional, antennas for up to 1kW, specifically designed to cope with modern frequency agile equipment. Incorporated into the latest range of tactical antennas are modern high strength/low stretch materials such as Kevlar and carbon fibre, giving tough, very light weight systems.

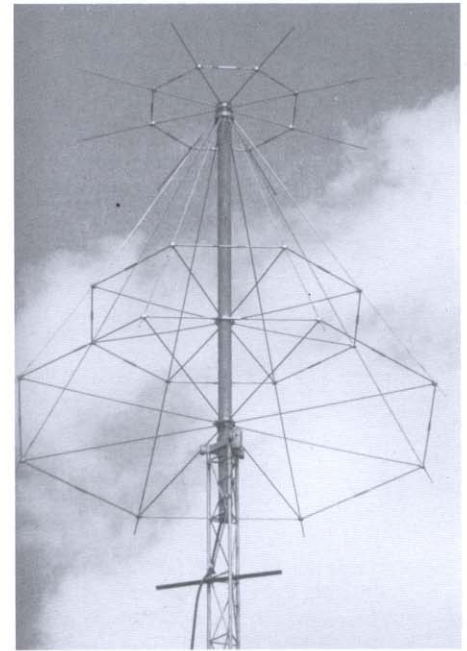

## Special Antennas

Again our flexibility comes to the fore when we are asked for a design for a specific task, or, an existing design may require special treatment to suit special applications. If your requirement comes within our capabilities we would be happy to help.

## Hire

A hire stock of Handheld, Base and Mobile Transceivers is available on short or long term hire, together with mobile towers and a range of antennas.





South Midlands Communications

## Wideband H.F. Antennas

### Wide Band Dipole FWB/2530 (Fixed)

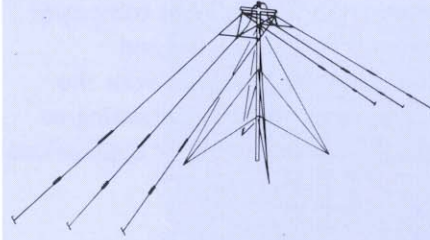

The FWB 2530 is a wide band H.F. dipole designed with cost and versatility in mind. Ideally supported on a single 18 mt (60') mast. This antenna can be used in fixed ground stations, roof mounted, or in semi-transportable situations. The antenna is centre fed via 50 ohms coaxial cable to a mast mounted 1kW balun transformer. The element ends are kept clear of the ground by use of polyester end tails.

TECHNICAL SPECIFICATION	
Frequency Range	2.5-30 MHz
Power	Rx - 1kW AVE
VSWR	3:1 max 2.1:1 AVE
Polar Diagram 'H' Plane	Generally omnidirectional
Polar Diagram 'E' Plane	30° - 90°
Gain	> 3 dbi
Impedance	50 Ohms unbalanced

### Terminated Folded Dipole TFD/TX TFD/RTX-05B (TFD/BB)

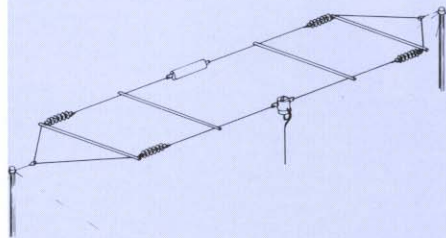

The TFD range of wide and semi wide antennas were designed with HF SSB outstations in mind. Cost effective and simple to install, the TFD range can be built to suit most situations. The TFD/BB gives full coverage from 2.5 to 30MHz, and the RTX/05B's can be designed to optimise a smaller band sector. The TFD/TX utilises ground mounted transformer and load, to obtain higher power rating.

TECHNICAL SPECIFICATION	
Frequency Range	2.5-30MHz (TFD/BB) 3:1 OF F <sub>0</sub> TFD/RTX 05B and TFD/TX
Power	RX-250 watts Rx-2kW (TFD/TX)
VSWR	2:1
Polar Diagram 'H' Plane	Generally omnidirectional
Polarisation	Horizontal
Impedance	50 Ohms unbalanced

### Terminated Vee

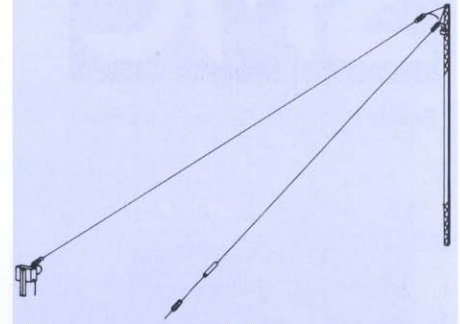

Derived from the classic Rhombic design, the Terminated Vee gives good directivity with a bandwidth of approximately 2:1 dependant upon design characteristics. Another cost effective design requiring only one support mast, and a wide range of power options, together with fixed, transportable, and tactical versions to suit most requirements.

TECHNICAL SPECIFICATION	
Frequency Range	5-30 MHz
Power	RX - 2KW
VSWR	< 2.5:1
Polarisation	Horizontal
Impedance	50 Ohms unbalanced

### Wide Band Dipole HBC 2-30

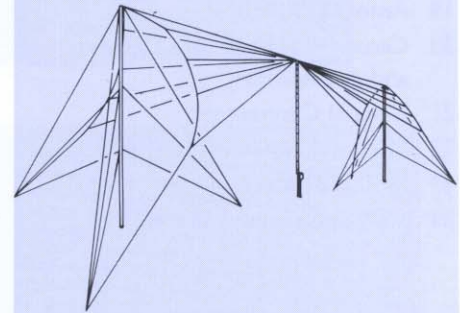

The HBC 2-30 range is a non loaded horizontal dipole arrangement that gives excellent efficiency by excluding the use of terminating loads or tuning units. Available in ranges from 2-30 MHz, 3-30 MHz and 4-30 MHz, and a wide range of power capability from receive to 10 kW, the HBC 230 can be tailored to suit most requirements. Ideal for short to medium haul circuits.

TECHNICAL SPECIFICATION	
Frequency Range	2-30, 3-30, 4-30 MHz (others upon request)
Power	Rx - 10 KW
VSWR	2.5:1 max. 2.0:1 AVE
Gain	8 dbi
Polar Diagram 'H' Plane	Omnidirectional
Impedance	50 Ohms unbalanced
Polarisation	Horizontal



South Midlands Communications

## Rotatable Log Periodics and Verticals

### LPI009 13-30 MHz R.L.P.A.

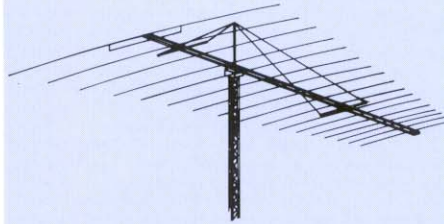

Constructed in high grade tubular aluminium alloy, the LPI009 can form the basis of a reliable fixed medium to long range link, and a multidirectional system when mounted on one of the SMC stock rotator systems for a full 360° azimuthal access. A full range of roof and ground mounting masts and towers is available, together with remotely controlled rotator systems to make a flexible and comprehensive system.

TECHNICAL SPECIFICATION	
Frequency Range	13-30 MHz
Power	2 kW AVE
VSWR	2:1 max
Forward Gain	13 dbi (average soil)
Impedance	50 ohms unbalanced
Polarisation	Horizontal

### LPI017 6.2-30 MHz R.L.P.A.

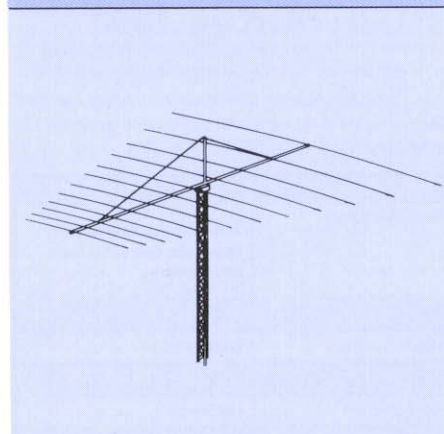

The LPI017 is a foreshortened design of array for use in areas where space and weight are limited. Ideal for Embassy and certain maritime applications where reliable medium to long range communications are required. Coupled with the R3501 rotator, the antenna can be remotely steered to give 360° azimuthal travel.

TECHNICAL SPECIFICATION	
Frequency Range	6.2 - 30MHz
Power	2kW average
VSWR	2.5:1max
Forward Gain	8 dbi at 6.2 MHz 12 dbi at 30 MHz (average soil)
Impedance	50 ohms unbalanced
Polarisation	Horizontal

### T.S and P.A. Series M.F./H.F. Mast Radiators

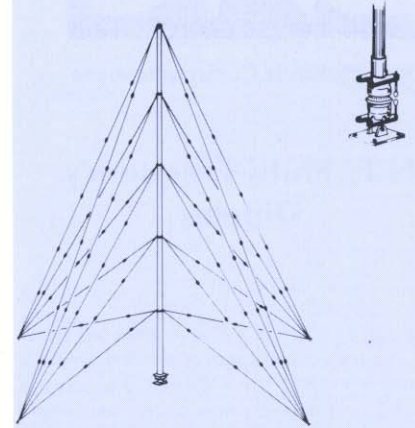

Based on the SMC aluminium and steel tubular masts, the mast radiator can be used in a number of situations. Primarily designed as a short range non directional beacon, in the HF bands it can also be used as a ¼ wave radiator to make a cost effective spot frequency antenna. Refer to PA2B, PA2BML, and TS Series masts for physical data.

TECHNICAL SPECIFICATION	
Frequency Range	200 MHz - 28 MHz (normally tuned via ATU)
Power	Rx - 30 kW
Polarization	Vertical
Impedance	2 - 10 ohms dependent upon operating frequency 50 ohms for ¼ wave length
Capacity	120 - 1500 PF dependent upon design
Polarisation 'H' Plane	Omni-directional

### LPI010 10-30 MHz R.L.P.A.

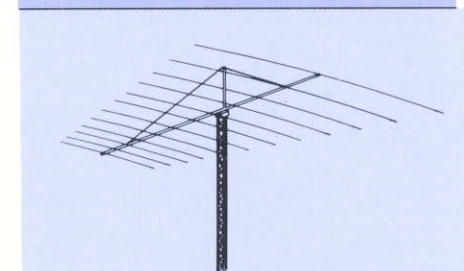

Constructed in high grade tubular aluminium alloy, the LPI010 can form the basis of a reliable fixed medium to long range link, and a multidirectional system when mounted on one of the SMC stock rotator systems for a full 360° azimuthal access. A full range of roof and ground mounting masts and towers is available, together with remotely controlled rotator systems to make a flexible and comprehensive system.

TECHNICAL SPECIFICATION	
Frequency Range	10 - 30MHz
Power	2kW
VSWR	2.0:1
Forward Gain	ave 4.5dBi
Impedance	50 ohms unbalanced
Polarisation	Horizontal



South Midlands Communications

## H.F. Multi-Frequency Dipoles

### T.D.A. Series Trap Dipoles

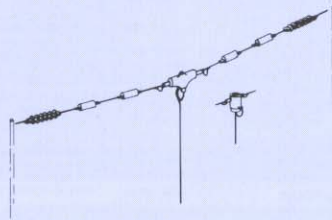
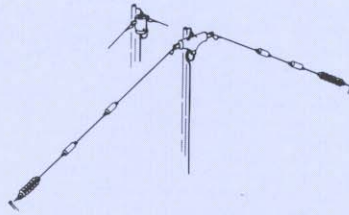

Designed with the non-technical installer in mind, our trap dipoles are in use throughout the world. Rugged construction and factory testing before despatch ensure that each antenna can be simply erected and forgotten. Available in up to 6 frequency design, with up to 1kW rated power, and a series of mechanical designs allow a flexible cost effective system when mounted on a SMC/PA2/BML mast.

TECHNICAL SPECIFICATION	
Frequency Range	2-30 MHz (up to 6 spot frequencies dependent upon channel spacing)
Power	150W
VSWR	Better than 2:1
Gain	3 dbi
Polarisation	Horizontal
Impedance	50 ohms unbalanced

### MCFD/CFD H.F. Fan Dipoles

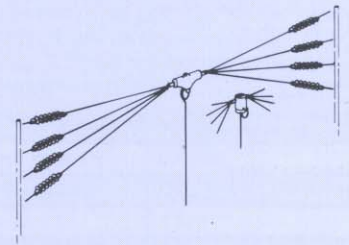
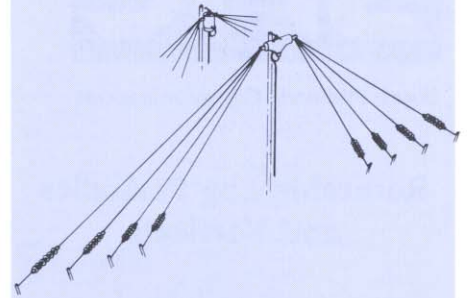

Comprising up to 4 resonant half wave dipoles on a common junction, the MCFD series are extremely cost effective. Not recommended for non-technical installers since site tuning is almost always required. Once installed the fan dipole provides a reliable and efficient system.

TECHNICAL SPECIFICATION	
Frequency Range	2-30 MHz (up to 4 spot frequencies)
Power	150W, 400W, 1kW PEP
VSWR	Better than 2:1
Gain	Up to 3 dbi
Polarisation	Horizontal
Impedance	50 ohms unbalanced



South Midlands Communications

## M.F. and H.F. Antennas

### Broad Band Cage Monopole

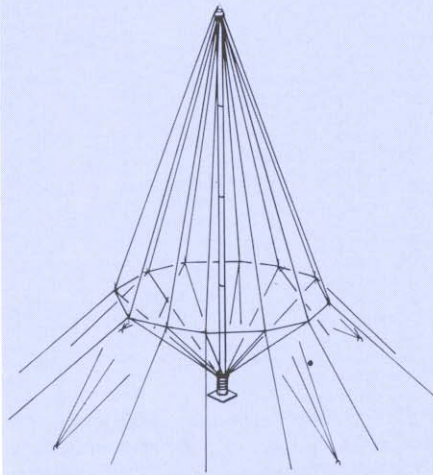

The B.B.C.M. series of vertical antennas are essentially omni-directional, with good ground and skywave 'E' plane polar diagrams. Used for short to medium circuits it is ideal for ground to air or ship to shore communications. Available in several frequency ranges from 2-30MHz.

TECHNICAL SPECIFICATION	
Frequency Range	2-6 MHz, 6-18MHz, 10-27MHz
Power	RX - 10kW
VSWR	Better than 2:1 at 3-1 band width
Gain	Up to 4 dbi
Polarisation	Vertical
Impedance	50 ohms

### Full Wave Cage Dipole

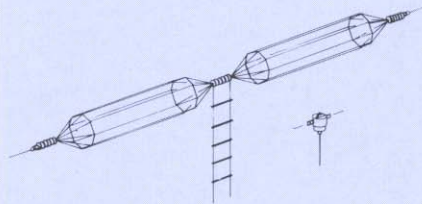

Primarily used as a broad band receive antenna, the full wave cage dipole has a primary impedance of 600 ohms giving power ratings up to 10KW. The full wave design gives strong bi-directional signal, coupled with low angle 'E' plane diagram.

TECHNICAL SPECIFICATION	
Frequency Range	2.5-30MHz (design band width 2.5:1 Fo)
Power	RX-10kW
VSWR	2:1
Polarisation	Horizontal
Impedance	600 ohm balanced or 50 ohms unbalanced

### Full Wave Cage Quadrant

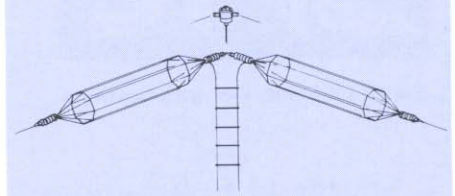

Using the same principle as the cage dipole, the quadrant antenna is supported on 3 masts, with the elements forming a 90° angle. This gives the antenna very good omni-directional characteristics in the 'H' plane. 'E' plane details are very similar to the cage dipole.

TECHNICAL SPECIFICATION	
Frequency Range	2.5-30 MHz (design bandwidth 2.5:1 of Fo)
Power	RX - 70kW
VSWR	2:1
Polarisation	Horizontal
Impedance	600 ohms balanced or 50 ohms unbalanced

### M.F. TEE Antennas

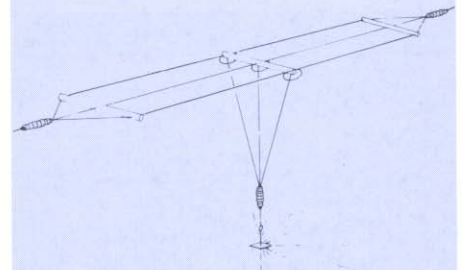

Primarily used in Non-Directional Beacon (NDB) systems where antenna tuning unit is available to match characteristics of antenna to the transmitter. To cope with wide frequency and power ranges, a family of 1, 2 and three wire systems is available in varying sizes for the best possible results.

TECHNICAL SPECIFICATION	
Frequency Range	150 - 550KHz
Power Rating	Up to 10kW
VSWR	ATU tuning normally used to compensate
Polarisation	Vertical
Capacitance	400-2000 pF dependent upon design/operating frequency
Radiation Resistance	0.1 to 10 ohms, dependent upon design/operating frequency



South Midlands Communications

## Simple H.F. Antennas

### CFDIA/CFDDQ Centre Fed Dipoles



SMC have taken the popular dipole design and produced a good quality, cost effective antenna which gives exceptionally good performance. Essentially a spot frequency design, the centre fed dipole can be constructed to suit many applications. Normally supplied complete with centre balun, and 30 m low loss coaxial cable, no other accessories are required, except of course suitable support masts.

TECHNICAL SPECIFICATION	
Frequency Range	2-30 MHz
Band Width	± 2% centre frequency
Power	RX - 2kW
VSWR	1.5:1
Gain	3 dbi
Polarisation	Horizontal
Impedance	50 or 75 ohms unbalanced

### LWL/I Long Wire

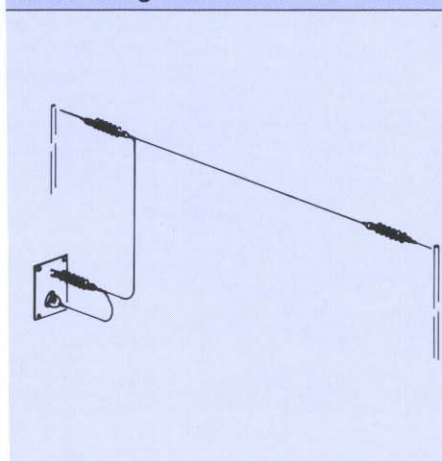

Normally used for receive only, the LWL/I is a non resonant antenna, which can also be used for transmission where a suitable antenna tuning unit is available.

TECHNICAL SPECIFICATION	
Frequency Range	Dependent upon ATU
Power	RX - 1kW

### T/I/A Single Wire Tee Antenna

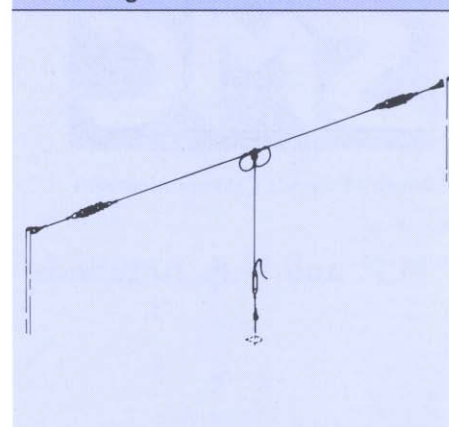

A simplified version of the M.F. tee antenna as previously described. Normally used in the upper M.F. bands for low power cost effective N.D.B.'s.

TECHNICAL SPECIFICATION	
Frequency Range	150-550KHz (using suitable ATU)
Power	Up to 1kW
VSWR	Determined by ATU
Polarisation	Vertical

### SW/2/B

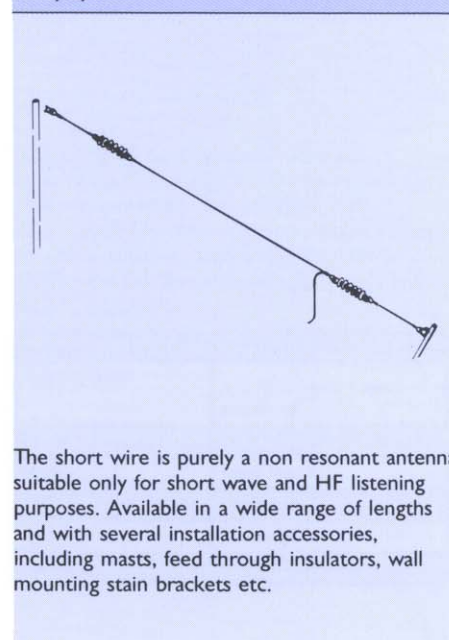

The short wire is purely a non resonant antenna suitable only for short wave and HF listening purposes. Available in a wide range of lengths and with several installation accessories, including masts, feed through insulators, wall mounting stain brackets etc.





South Midlands Communications

## H.F. Balun Transformers

### T.A. Series Tacticals and Transportables

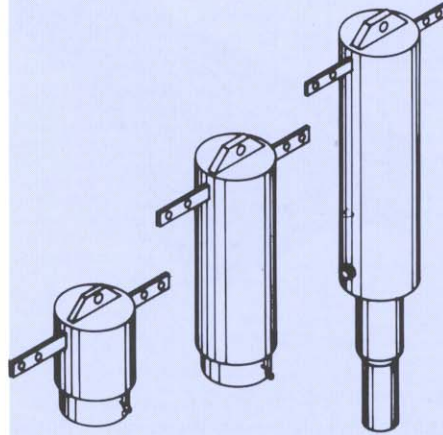

This series comprises a rugged, lightweight design with a very wide range of power ratings and ratios. All are non-hygrascopic with protected connectors, strain relief fittings and finished in hard bake paint, with blackedised stainless steel arms. Power ratings Rx to 1kW ratios from 1:1 to 16:1.

TECHNICAL SPECIFICATION	
Frequency Range	1.5 - 30 MHz
Insertion Loss	Less than 0.3db
VSWR	Less than 1.2:1 (2-30 MHz)
Balance Ratio	Better than 26db
Temperature Range	-40°C to +70°C
Static Drain	Included
Special designs can be undertaken	

### HF10 Series

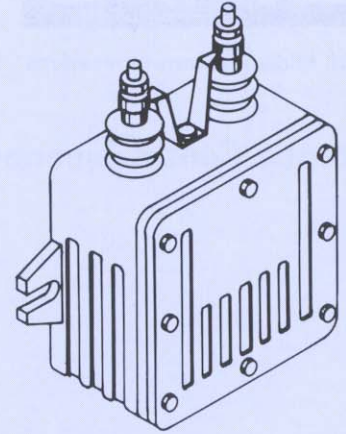

The heavy duty HF10 series again is cased in a custom designed aluminum casing, capable of handling 1kW average with ratios between 1:1 and 12:1.

TECHNICAL SPECIFICATION	
Frequency Range	1.5 - 30 MHz
Insertion Loss	Less than 0.3db
VSWR	Less than 1.2:1 (2-30 MHz)
Balance Ratio	Better than 26db
Temperature Range	-40°C to +70°C
Static Drain	Included
Special designs can be undertaken	

### HF4 Series

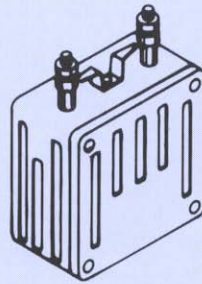

Encased in custom designed fluted cast aluminium cases, the HF4 series is a 400 Watt range of mounted transformers. Although power capacity is high, the HF4 has been designed with H.F. receiving arrays in mind. Internal static drain dispenses high voltages that can be associated with static build up or lightning induced EMF. Power ratings Rx to 400W ratios 1:1 to 12:1.

TECHNICAL SPECIFICATION	
Frequency Range	1.5 - 30 MHz
Insertion Loss	Less than 0.3db
VSWR	Less than 1.2:1 (2-30 MHz)
Balance Ratio	Better than 26db
Temperature Range	-40°C to +70°C
Static Drain	Included
Special designs can be undertaken	

### HF30 to HF300

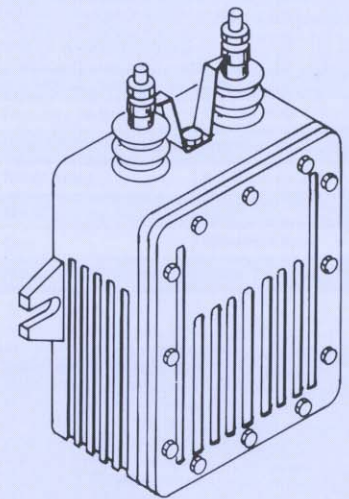

A full range of high power transformers with the same pedigree of the preceding units with power ratings from 3kW to 30kW, ratios from 1:1 to 12:1.

TECHNICAL SPECIFICATION	
Frequency Range	1.5 - 30 MHz
Insertion Loss	Less than 0.3db
VSWR	Less than 1.2:1 (2-30 MHz)
Balance Ratio	Better than 26db
Temperature Range	-40°C to +70°C
Static Drain	Included
Special designs can be undertaken	



South Midlands Communications

## Antenna Centre Junctions

### CCJ/1

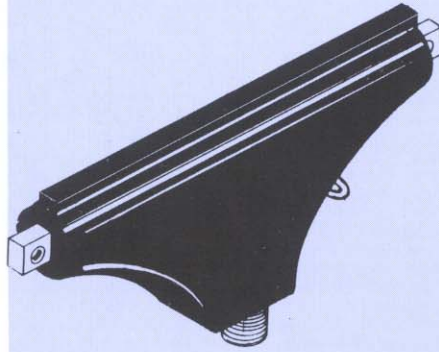

The CCJ/1 series of antenna junction units are moulded from heavy duty epoxy resin with pre-fitted end lugs, connectors and strain relief eyes. It is a simple junction (no transformer) and has been designed to give years of trouble free service in very harsh environments. Supplied with all necessary fittings.

TECHNICAL SPECIFICATION	
Power Rating	1KW
Frequency Range	1.5 - 30 MHz
Temperature Range	-40° to +60° (HEAT DISTORTION AT +88°C)
Breaking Strain	600Kgs at +30°C
Connectors	UHF, N, C, (50 or 75 ohms)
Weight	410 Grams
Fittings	Brass (tin plated) stainless steel, galvanised steel.

### AJU

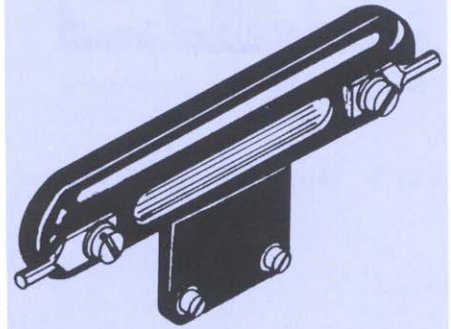

A very simple ultra lightweight moulding in carbon loaded polypropylene for use with turn balanced feeder, and very light weight balanced antennas.

TECHNICAL SPECIFICATION	
Size	3.25 Inches O.A. length
Fittings	Stainless Steel
Breaking Strain	100kgs approx at +30°C

### CCJ/2



Generally used in tactical/transportable systems, the CCJ/2 is a lightweight carbon loaded polypropylene unit, with tough but light weight construction, supplied with all fittings.

TECHNICAL SPECIFICATION	
Power Rating	200 Watts
Frequency Range	1.5 - 30 MHz
Breaking Strain	250kgs at +30°C
Connectors	UHF, BNC as standard, also available in 'N' and 'C'
Weight	110 Grams
Fittings	Brass (cadmium plated) stainless steel



South Midlands Communications

## Transmission Lines and Loads

### Transmission Lines and Loads

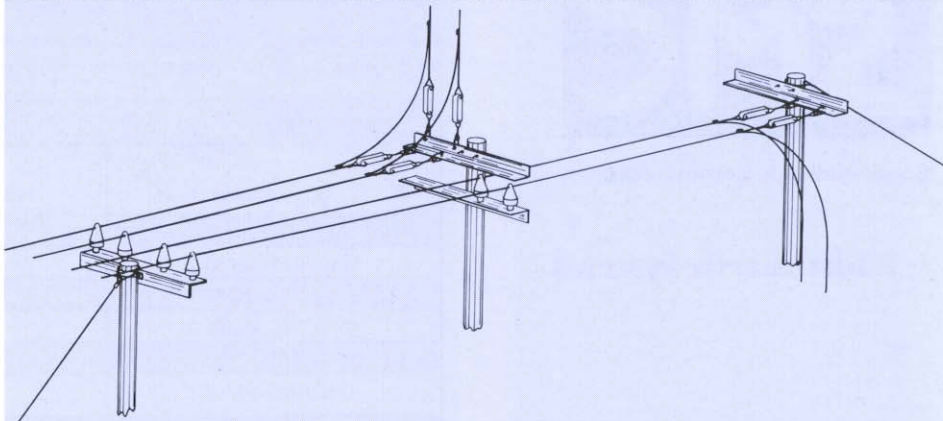

A system of single and double balanced transmission routes for power ratings up to 10kW, with spacings giving characteristic impedances of 300 and 600 ohms as standard. The system consists of galvanised steel support units, with intermediate end, corner and terminating route poles.

### Antenna Mounted Loads

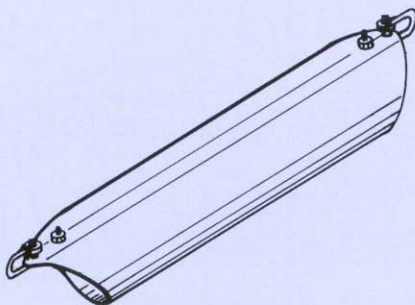

In line loads for terminated antennas, of various values and power ratings up to 250 Watts. Fibreglass housing ensures completely passive performance and excellent environmental resistance.

### Feed Through Panels

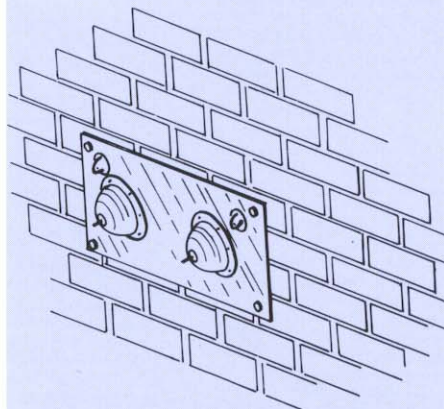

A full range of single and double feed through insulator panels for wall or bulkhead mounting, with strain relief for downleads.

TECHNICAL SPECIFICATION	
Panel	Galvanised Mild Steel
Insulators	Pyrex Bowl Type 6" or 2½" Dia
Impedance	Normally 500 ohms
Power Rating	Rx to 10kW
Frequency Range	1.5 - 30MHz

### Terminating Lines and Loads

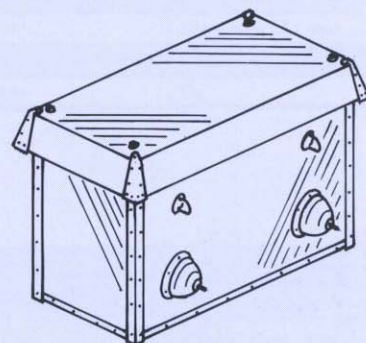

The T.R.U. series of terminating loads are designed in a series of power ratings from 100 Watts to 2.5kW, with a range of impedances from 150 to 600 ohms.

TECHNICAL SPECIFICATION	
Frequency Range	1.5 - 30 MHz
Impedance	Normally 300 to 600 ohms
Power Rating	100 Watts to 2.5kW
VSWR	1.2 - 1
Case	Galvanised Steel
Mounting	3 inch O.D. tube mount

### Coaxial Loads

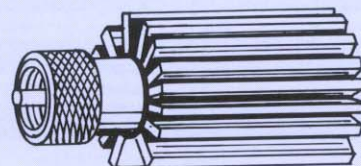

A wide range of 50 ohm loads for use in coaxial line testing, or hybrid circuits. Available with UHF or 'N' connectors, 10 - 150 Watts.



South Midlands Communications

## Radial Earth Systems

SMC Ltd. manufacture a wide range of radial earth systems, suitable for use with vertical antennas, and ground dependent wire antennas.

The standard range normally has 36 soft stranded copper radials, fitted to a 30cms square copper plate. Lengths may be varied to suit site requirements.

### Standard Range

Type Number	No. of Radials	Length of Radial metres	Plate Dims cms
SMC/RES/36/30-1	36	30	30 × 30
SMC/RES/36/30-2	36	30	60 × 60
SMC/RES/36/45-1	36	45	30 × 30
SMC/RES/36/45-2	36	45	60 × 60
SMC/RES/50/30-1	50	30	30 × 30
SMC/RES/50/45-1	50	45	60 × 60

Many other configurations may be manufactured to order, and central plates may be manufactured to suit specific antennas or sites.

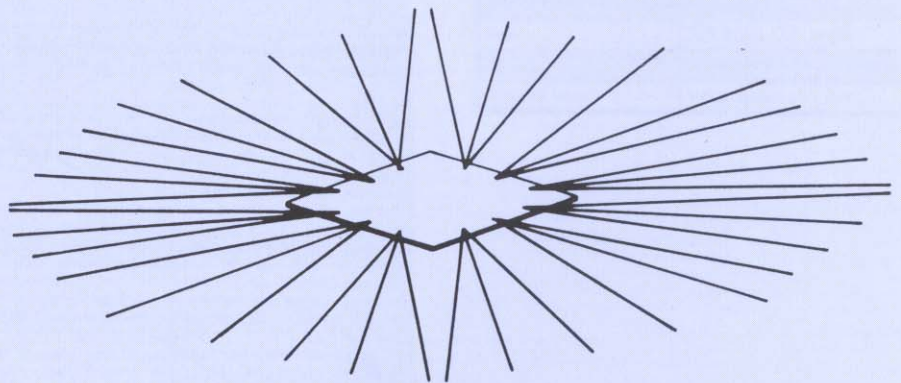

### Portable Radial Earth Systems

Up to 12 × 10 MT radials complete with earth spikes, storage spools etc. all supplied in galvanised steel or A.B.S. cabinets for rugged vehicle mounted systems.

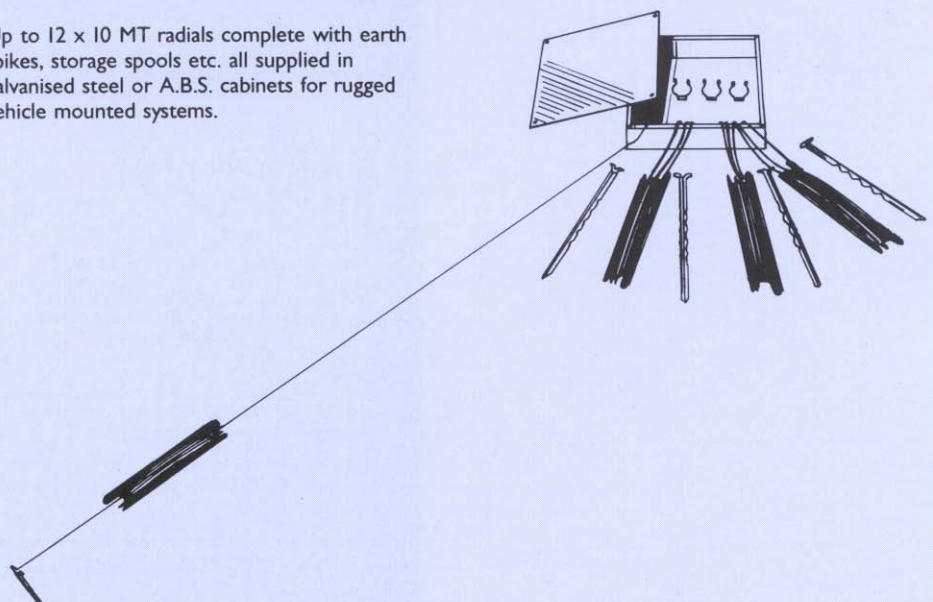

### MECHANICAL SPECIFICATION (STANDARD RANGE)

Construction	Fully prefabricated, copper rivetted and soldered joints, protected by bitumastic solution.
Wire Radials	Soft high conductivity pure stranded copper normally type No. 7/0.737.
Copper Pegs	May be supplied as an optional extra for each radial.
Finish	Normally self colour, but central plate may be electro-tin plated for extra corrosion resistance.



South Midlands Communications

## Tactical Antennas

### TDLS (Tactical Delta Loop System)

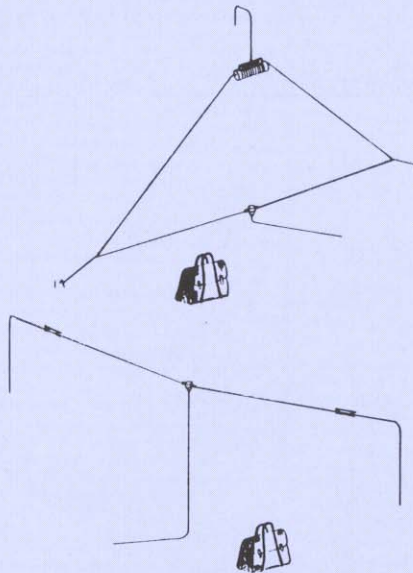

The TDLS is a wide band delta loop and dipole system giving complete flexibility between 2 dipole antennas, and, by re-configuring the low frequency dipole, a wide band directional loop can be erected. Normally erected on natural supports, masts can be supplied if necessary. The system is supplied complete with its own kit bag and feeder cables.

TECHNICAL SPECIFICATION	
Frequency Range	Delta loop 2-12 MHz, (up to 60 MHz with degraded polar diagram). Dipoles 2-12 MHz and 12-30 MHz.
VSWR	2.0:1 max
Power Rating	Receive to 1kW
Gain	Delta loop up to 7dbi, Dipoles 3dbi
Construction	Lightweight Kevlar and prestretched polyester antennas, glass fibre balun housings and cast alloy load. All fittings drab olive or matt black.
Weight	1kW version 32Kg

### "Manpack" LW8 Series Tactical Dipoles

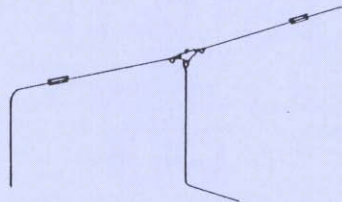

The LW8 tactical dipoles is a very lightweight adjustable dipole, for use in spot frequency systems. Supplied complete with coaxial feeder cable, and kit bags (optional extra). The LW8 offers a cost effective efficient antenna.

TECHNICAL SPECIFICATION	
Frequency Range	3-30MHz (2-30MHz as special design)
Power Rating	250 Watts
Weight	1Kg

### TWB 2530 Wide Band Dipole

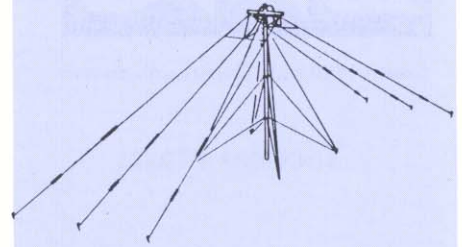

Supplied as a completely integral system, with its own mast and erection tools, the TWB is a relatively efficient skywave antenna. Constructed in Kevlar and fibreglass composites, this system is exceptionally lightweight and tough. All fittings and carry bags have drab olive and matt black finish, and the system can be erected and "on air" in as little as 30 minutes.

TECHNICAL SPECIFICATION	
Frequency	2.5 - 30MHz
Power Rating	400 Watts or 1kW
VSWR	2.0:1 average 2.5:1 max
Horizontal Polar Diagram	Omni-directional
Weight	3Kg

### TLP Tactical Log Periodic (Provisional)

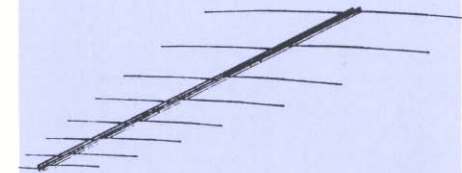

Lightweight folding log periodic array in the 30-100MHz range. Manufactured in high grade aluminium alloy, with green anodised finish. Supplied with feeder cables and kit bag.

TECHNICAL SPECIFICATION	
Frequency Range	30 - 100MHz
Power Rating	500W
Gain	6dbi
VSWR	2:1
Number of Elements	8
Assembly Time	5 Mins



South Midlands Communications

## Tactical Masts

### Manpack Portables 5-7 Mtrs

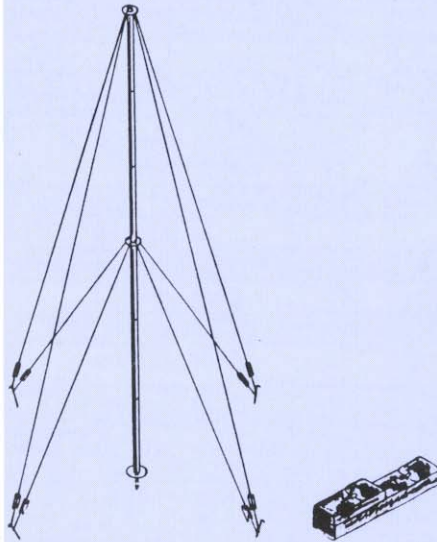

The M.P. range of manpack portables are ultra lightweight sectional masts for use with our LW8 series antennas, or any other lightweight antenna. They can also be adapted as a short radiating mast. Supplied complete with shoulder bag and all accessories.

TECHNICAL SPECIFICATION		
	FIBREGLASS	ALUMINIUM ALLOY
Height	5m 7m	5m 7m
Weight	3.2 Kg 3.7 Kg	3.8 Kg 4.5 Kg
Section Dia.	32mm 32mm	38mm 38mm
Head Loading	13.6Kg 11.3Kg	15.9 Kg 13.6 Kg
Dimensions All	100 x 6.4 x 7.6cms	
Finish	Painted drab olive or matt black	Matt black or green anodised

### Micro-Mast 4MT

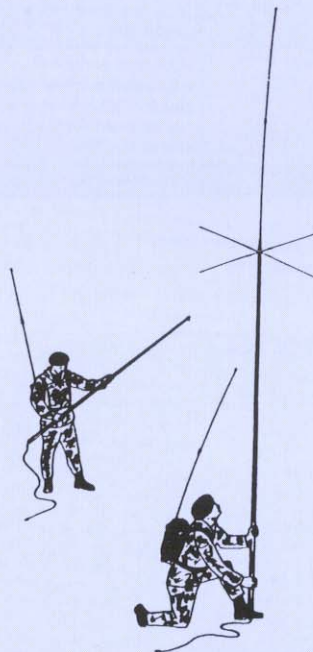

Primarily designed as an aid to extending the range of VHF hand portable transceivers, the micro-mast incorporates a top coaxial connector, telescopic action with central feed coaxial cable, ground mounting hardware and kit bag. A series of VHF and HF antennas are available for top mounting.

TECHNICAL SPECIFICATION	
Height	4 m
Weight	1.5 Kg
Packed Size	60 x 7 x 7cms
Finish	Matt black and olive green



South Midlands Communications

**H.F./V.H.F./U.H.F.  
Mobile Antennas**

**HW4 and PRO2000 Series**

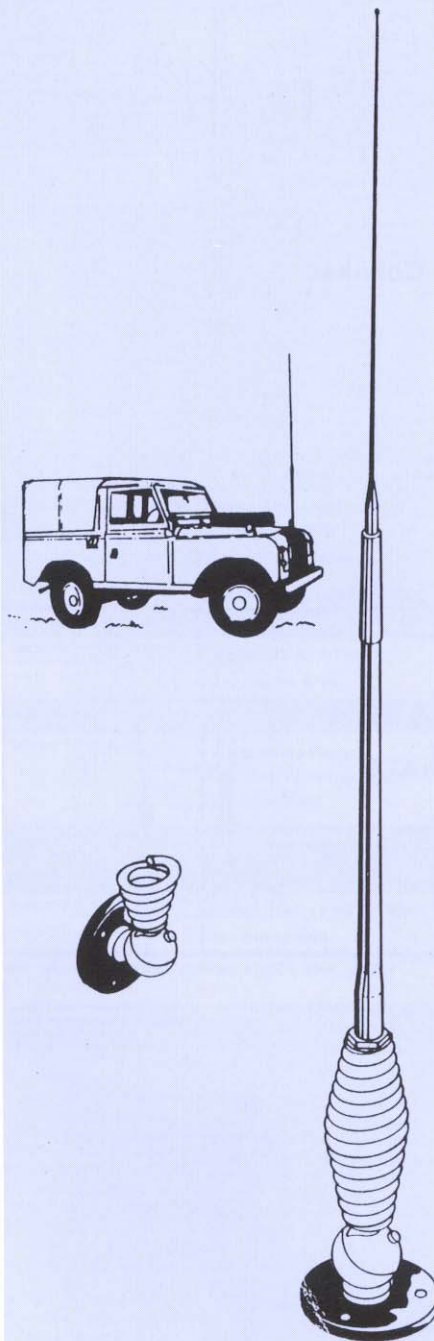

**HF Mobile Whips**

This series of H.F. mobile whips are rugged spring mounted antennas for H.F. SSB communications systems.

**The HW4** is a single frequency whip, which is exceptionally efficient. Base fed, it can be supplied with additional centre sections for frequency changes.

**The PRO** series is mounted on the same rugged basemount, but has up to six factory tuned frequencies selectable by a flying plug and lead arrangement.

TECHNICAL SPECIFICATION	
Frequency Range	2-30MHz
Power Rating	150W (higher by special arrangement)
VSWR	2:1
Impedance	50 ohm (nominal)
Channels	HW4 (one) PRO 2000 (1-6)

**V.H.F./U.H.F. and  
Mobile Antennas**

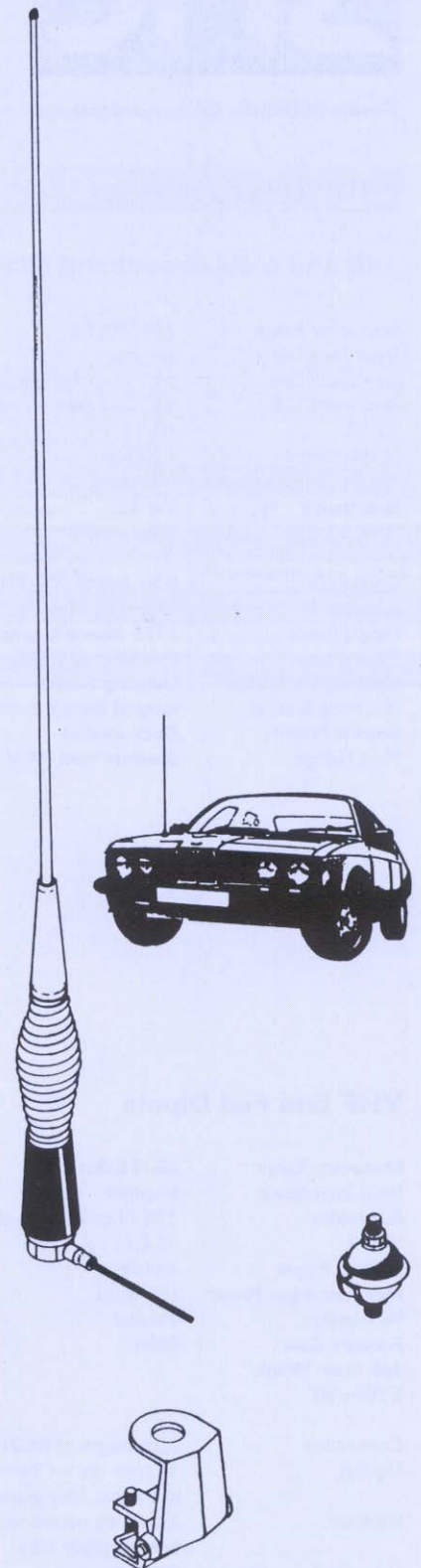

The Windsor range comprises a series of base mounts, and components to give a wide range of antenna configurations. All fittings are interchangeable.

TECHNICAL SPECIFICATION	
Frequency Range	60-500 MHz
Elements	1/4X, 3/8X, 1/2X, 5/8X, 7/8X
Mounts	Wing mount, roof mount, gutter mount, trunk mount, magnetic mount.
Whip Adaptors	Folding, Fixed, Spring
Gain	0-4.5 dbd



South Midlands Communications

**UHF/VHF Antennas**

**3dB and 6 dB Broadband Glassfibre Colinear**

Frequency Range	138-500MHz
Input Impedance	50 ohms
Bandwidth 3dB	±4% of centre frequency
Bandwidth 6dB	±3.5% of centre frequency
VSWR	<1.5:1
H Plane Ripple	<±0.5dB
Maximum Input Power	150 watts
Polarisation	Vertical
Forward Gain	3dBd or 6dB
Connection	0.5m length of RG213 c/w 'N' type socket
Dipoles	11mm dia brass tube
Dipole Feeds	PTFE dielectric coaxial cable
Shroud	Parallel grey glassfibre tube
Lightning Protection	Direct grounded
Mounting Bracket	Integral diecast aluminium alloy grade LM6
Bracket Finish	Black anodise
Mast Fixings	Stainless steel M8 V bolts grade A2-70

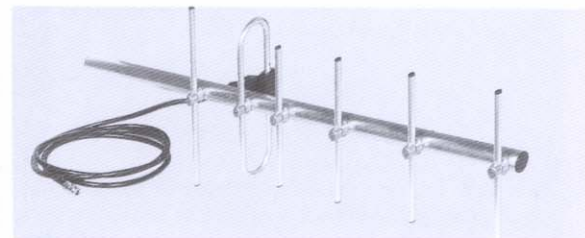
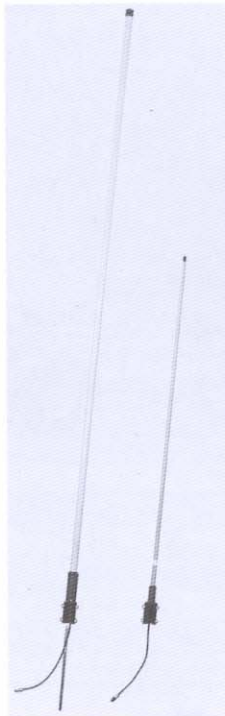

**VHF & UHF Yagi Antennas**

Frequency Range	88-500MHz
Input Impedance	50 ohms/(75 ohms)
VSWR	<1.5:1
Front To Back Ratio	16dB
Maximum Input Power	150 watts
Polarisation	Vertical & horizontal

Connection	3m length of RG213 c/w 'N' type socket (RG11/UR57)
Element	VHF 19.0mm dia x 1.6mm wall, UHF 12.7mm dia x 1.6mm wall
Support Boom	aluminium alloy grade 6063T6 31.7mm dia x 2.6m wall aluminium alloy grade 6082T6
Fasteners	Stainless steel grade A2-70
Saddle Clamps	Diecast zinc alloy
Insulator	Epoxy resign encapsulant
Lightning Protection	Direct grounded
Mounting Bracket	COP series (not included)

**VHF End Fed Dipole**

Frequency Range	68-174MHz
Input Impedance	50 ohms
Bandwidth	±3% of centre frequency
VSWR	<1.5:1
H Plane Ripple	<±1dB
Maximum Input Power	150 watts
Polarisation	Vertical
Forward Gain	0dBd
3dB Beam Width	
E Plane	80°
Connection	0.5m length of RG213 c/w 'N' type socket
Dipoles	38.1mm dia x 1.2mm wall aluminium alloy grade 6063T6
Insulator	35mm dia reinforced resin bonded paper tube
Lightning Protection	Direct grounded
Mounting	Inside scaffold tube
Mounting Brackets	CPC clamps (not included)
Typical Weight	VHF low 2.5kg, VHF med 1.8kg, VHF high 0.9kg
Typical Length	VHF low 3.5m, VHF med 2.5m, UHF 1.6m
Typical Wind Loading @ 45m/s	VHF low 110N, VHF med 51N, VHF high 38N

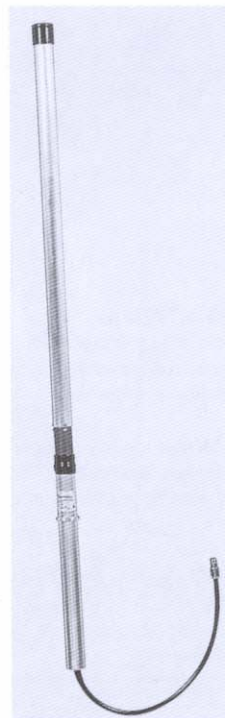





South Midlands Communications

## Tubular Support Masts

### PA2/B Series

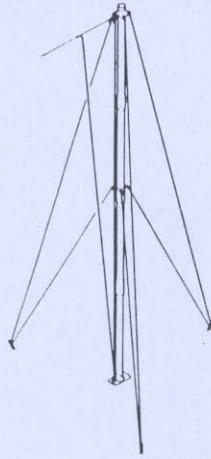

This series of portable sectional aluminium alloy masts are constructed in 48mm diameter x 7 gauge wall sections in HE30 TF material. No less than 50 models are available in a range of section sizes, guying systems, and other variations.

SPECIFICATIONS/RANGES	
Sections	48mm OD 7G HE30 TF 2, 3 and 4m lengths
Heights	6.1 to 18.4 m (20 - 48 ft.)
Guying Material	Pre-stretched Polyester (standard) Parafil (type 'A' or 'F'), Galvanised Steel
Head Loads	45 - 136Kg Horizontal (dependant upon design)
Erection	Above 10 m by falling derrick or climbing steps

Roof mounting and special versions available upon request

### PA2/BML Series

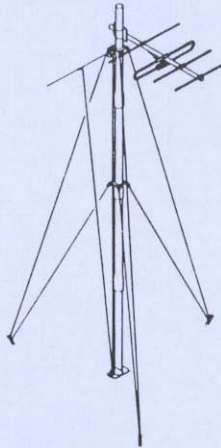

Closely related to the PA2/B series masts, the ML range is lighter duty to provide a more cost effective system where operational conditions allow. Always supplied with transport bag and simple erection tools.

SPECIFICATIONS/RANGES	
Sections	50mm OD 14g HE30 TF 6 feet long
Heights	6.1 to 18.4 m (20 - 48 ft.)
Guying Material	Pre-stretched Polyester (standard) Parafil (type 'F' or 'A'), Galvanised Steel
Head Loads	60 - 80Kg Horizontal
Erection	Above 10 m by falling derrick

Roof mounting and special versions also available.

### PFG Series Portable Fibreglass

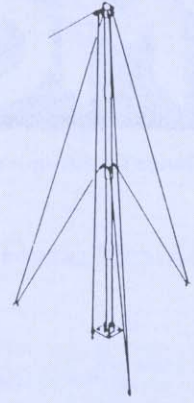

A further development of the PA2 series masts is this lightweight range of fibre-glass sectional masts for areas where non-conductive or R.F. invisibility is desirable.

SPECIFICATIONS/RANGES	
Sections	50mm OD x 2m x 6mm wall
Heights	5.5 - 11Mtrs (18 - 36 feet)
Guy Material	Pre-stretched polyester or Parafil
Head Loads	40 - 60 Kg horizontal
Erection	No erection kit required
Finish	All drab olive and matt black



South Midlands Communications

## Telescopic Masts/Towers

### Mobile Versatowers

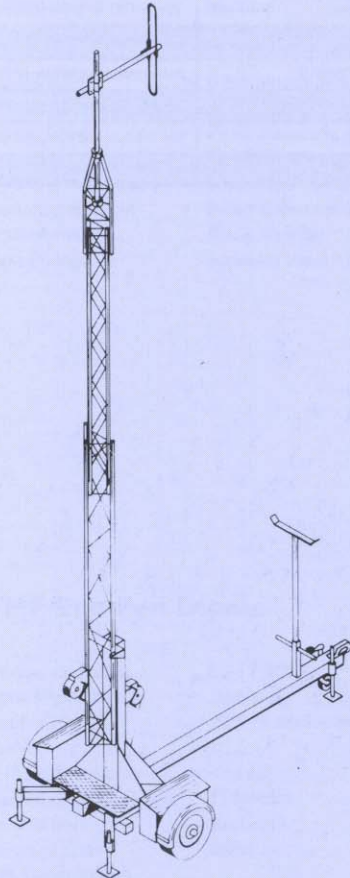

The mobile versatower is available with a wide range of specifications and accessories. Supplied complete with brakes, road lights, and panniers (24m up). All components including chassis members are hot dipped galvanised, winches can be manual, or 24V DC, with accessories such as generators, and other equipment able to mount on the chassis.

SPECIFICATIONS	
Extended Heights	7.5 - 30m
Trailer Size (Towing spec)	2.28m wide x 5.88 m long x 3.05m high
Trailer Extended	5.92m wide x 7.7m long
Kerb Weight	1524 Kg (M100 30m) 945Kg (7.5m)
Headload/Wind Loading	As standard range

### Versatower Crank up Masts

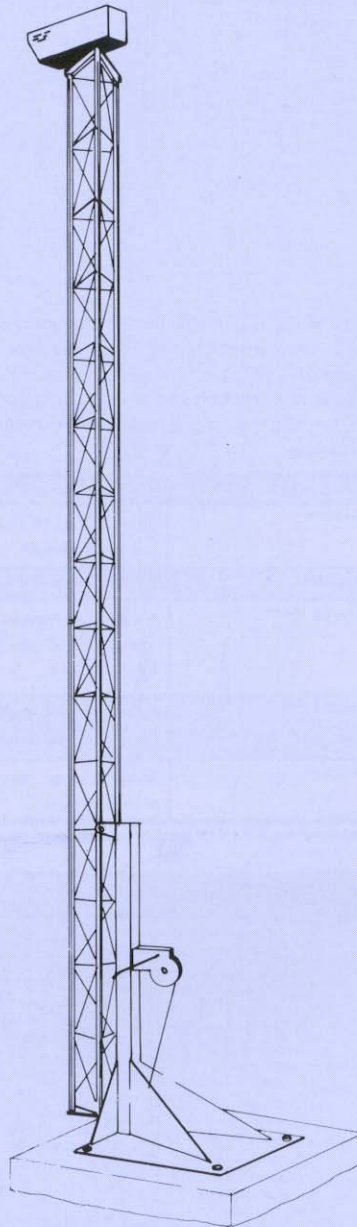

With over 60 models available in 6 base configurations, the very rugged versatower provides a cost effective "off the shelf" solution to many antenna, camera support and floodlighting problems. Constructed in high grade galvanised steel with a wide range of accessories, including guy kits for masts over 18m.

SPECIFICATIONS	
Extended Heights	7.5 - 30m
Nested Heights	3.5/7.3/17.8m
Wind Speeds	Up to 193kph (dependent upon model/loading)
Dead Loads	Up to 56Kg (dependent upon model/loading)
Load Area	Up to 4.6 square m (dependent upon model/loading)

### Pneumatic and Push up Masts

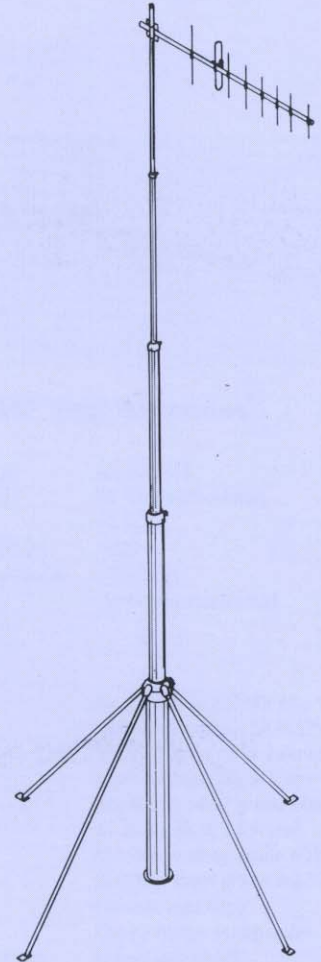

For mobile or semi-permanent systems, the telescopic Hilomast range have a wide variety of accessories including field stands, vehicle side and through roof mountings, guy kits, first section climbing steps, foot pumps, compressors (12/24V DC, 115/230V AC), and various antenna mounting arrangements.

The push up range is provisional, but will consist of a series of portable and vehicle mounted masts up to 12m in height.

TECHNICAL SPECIFICATION	
Extended Heights	5-28m
Nested Heights	1.5 - 4.5m
Wind Speed	Up to 160kph (dependent upon model/loading)
Dead Loads	Up to 50Kg (dependent upon model/loading)
Load Area	Up to 3000 square cms (dependent upon model/loading)



South Midlands Communications

## Lattice Towers and Masts

### Series 30

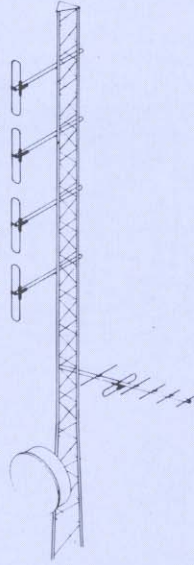

A stock system of fixed self supporting towers in 3 or 4 leg configuration, constructed in high grade galvanised tubular steel. A full service is available including computer calculations for proof of integrity. Accessories include lighting kits, rest and work platforms, various head configurations, and foundation designs.

SPECIFICATIONS	
Heights Available	6-160m (6 and 7.5m sections)
Loadings	dependent upon design requirements
Wind Speed	to design requirements

### Unimast 40



The UN40 range is a medium duty guyed lattice mast with 2 versions available: Knock down for freight costs, and less expensive all welded for UK use where pack volumes are not critical. The UN40 is provided with a ladder on one face, and a range of climbing safety hardware is available where required.

SPECIFICATIONS	
Heights Available	6-50m (3m sections)
Face Width	40cms
Construction	pre-fabricated high grade steel, with hot dipped galvanised finish

### WD25

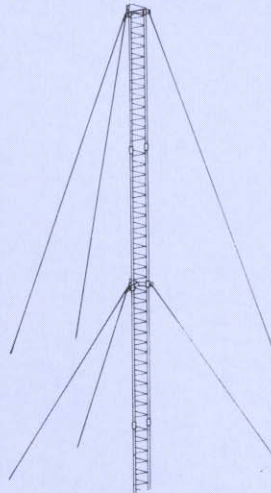

A range of light weight very cost effective "knock down" or prefabricated guyed masts, incorporating climbing rungs on all faces, with tubular legs and solid bracings constructed in galvanised high grade steel. Typically for use with wire antenna systems, and V/UHF multiple arrays.

SPECIFICATIONS	
Heights Available	6-160 m (3m sections)
Face Width	25 cms
Headloads and Wind Speed Rating	dependent upon design height



South Midlands Communications

## Mast Lighting

### Unilamp - Neon

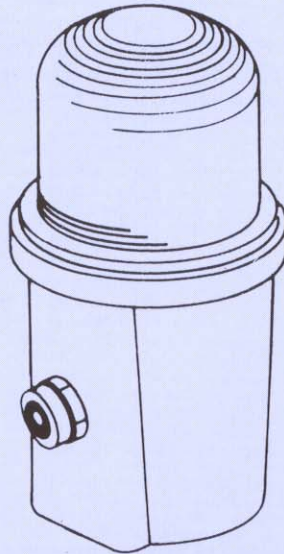

For low intensity category 'A' situations, the Unilamp consists of a cast aluminium body with side or base cable entry, and a range of brackets for every type of mounting problem, including double fittings. The light source is a neon spiral cold cathode tube, which emits red light through the clear glass dome. Available in 12 and 24 V DC 110/120 or 230/240 V AC.

### OB2 Double Filament Fitting

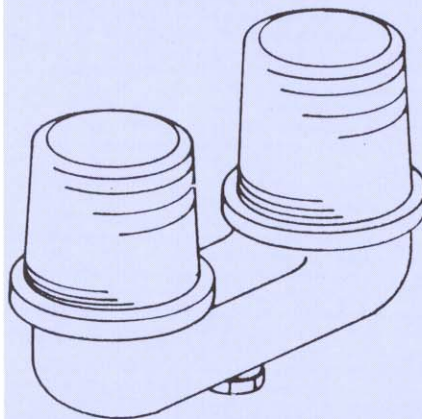

The OB2 fitting comprises an aluminium base casting with glass domes and stainless steel fittings. The glass domes are easily removed for bulb replacement, and the dome and securing ring remains suspended on a short chain to avoid dropping. The OB2 takes 2 E.S. bulbs of up to 100w rating and is supplied complete with mounting brackets and cable gland.

### Obsta Neon Single Fitting

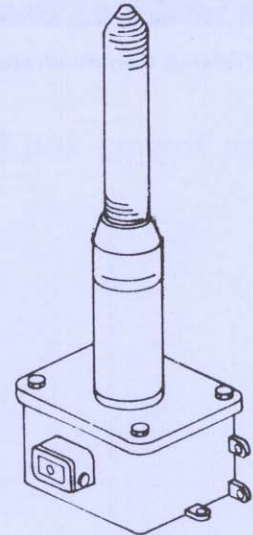

Obsta neon discharge lamp fitting, low pressure cold cathode type tube ensures long life. The tube is screened against RF interference with a fine mesh, and is mounted on a cast aluminium base unit with weatherproof cable entry gland and vertical or horizontal mounting flanges. Several units may be bracketed and used in parallel. Available in 24 and 48V DC, 115V AC (60 Hz) or 220/240V AC (50 Hz).

### Daylight Sensitive Switches

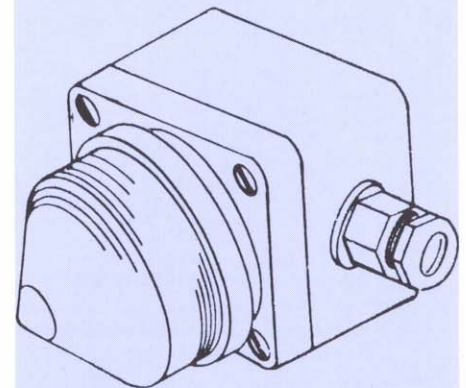

SMC daylight sensitive switch automatically operates when the level of daylight reaches pre-set values, with a built-in delay of 30 seconds to avoid switching due to lightning, etc. The daylight sensitive cell is bayonet mounted for easy and quick maintenance in the event of failure, and connectors, etc. are housed in a die-cast aluminium or ABS weather-proof box. Normally supplied with 220V AC operating voltage and contact rating for 1 kW load. Other voltages available upon request.



South Midlands Communications

## Tower Earthing Equipment

Copperbond earth rods provide long lasting, easily driven electrodes by combining corrosion resistance of copper with the rigidity and strength of steel. These rods have a uniformly thick copper sheath molecularly bonded to a round carbon steel core.

The layer of permanently bonded copper assures extended life, even in corrosive soils. Points are machined to provided easy driving. The other end of the rod is chamfered to prevent mushrooming when driven into the ground.

## Tower Earthing Equipment



Drive Bolts



Lightning Finials



Couplers

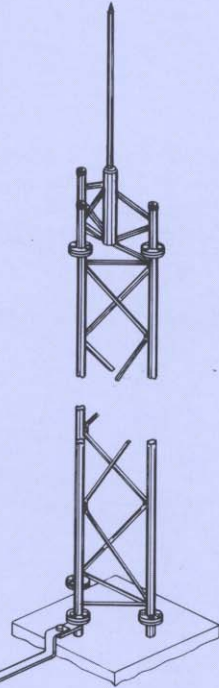

Copper and Aluminium Tape



Copperweld Earth Rods

Extendable copperbond earth rods available in the following sizes:  
 1/2" dia. in 4' lengths  
 3/8" dia. in 4,6,8' lengths  
 3/4" dia. in 4,6,8' lengths  
 All rods may be connected by external coupler and driven to greater depths.

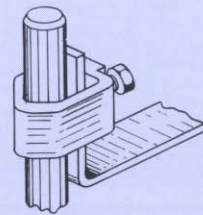

Brass Top Caps

## Earth Tape

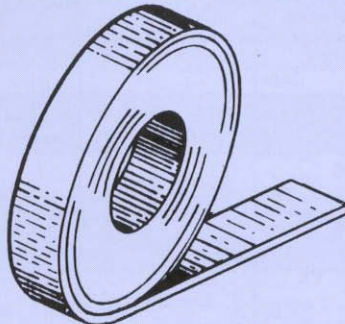

Available in aluminium or pure copper in various sizes, normally from stock.

Copper: 1/2" x 1/16"  
 1/2" x 1/8"  
 3/4" x 1/16"  
 3/4" x 1/8"  
 Aluminium: 1" x 1/8"

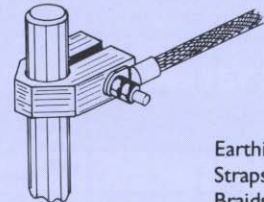

Earthing Straps Braids



South Midlands Communications

**DRCI Remote Control Unit for R3501/2/3 Very Heavy Duty Rotators**

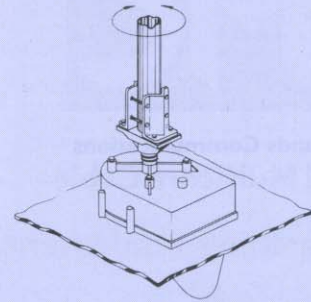
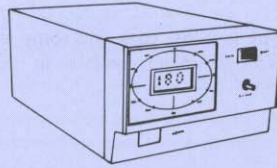

**Antenna Rotators**

The G series of azimuth and elevation Rotators are for light to medium duty use with a range of features including variable speed, computer control, (see specifications for details) and combined AZIMUTH/ELEVATION systems.

**G400/G400 RC**

Light/Medium-duty, for small and medium to large-size UHF, VHF, FM radio and television antenna arrays.

Power consumption: 40 VA  
 360° rotation time: 50 sec  
 Rotation torque: 400 kg-cm (28.3 ft-lbs)  
 Stationary torque: 1500 kg-cm (108.3 ft-lbs)  
 Max. vertical load: 200 kg (440 lbs)  
 Max. antenna wind load: 0.75 m<sup>2</sup> x 0.6m  
 Mast diameter: 38-63 mm (1½-2½ in.)

**G2000 RC**

Extra Heavy-duty, for large amateur and commercial UF arrays.

Power consumption: 100 VA  
 360° rotation time: 67 sec  
 Rotation torque: 2000 kg-cm (144 ft-lbs)  
 Stationary brake torque: 10,000 kg-cm (723 ft-lbs)  
 Max. vertical load: 250 kg (550 lbs)  
 Max. ant. surface area: 1.5 m<sup>2</sup> x 0.6m  
 Mast diameter: 48-63 mm (2-2½ in.)

**G600/G600 RC**

Medium-duty for small HF and large-size UHF, VHF, FM radio and television antenna arrays.

Power consumption: 40 VA  
 360° rotation time: 53 sec  
 Rotation torque: 600 kg-cm (42 ft-lbs)  
 Stationary torque: 4000 kg-cm (288 ft-lbs)  
 Max. vertical load: 200 kg (440 lbs)  
 Max. antenna wind load: 0.75 m<sup>2</sup> x 0.6m  
 Mast diameter: 38-63 mm (1½-2½ in.)

**G500A**

Elevation rotator, for satellite earth station and other space communication antennas.

Power consumption: 30 VA  
 180° rotation time: 61 sec  
 Rotation torque: 1000 kg-cm (73 ft-lbs)  
 Stationary brake torque: 2000 kg-cm (144 ft-lbs)  
 Pointing accuracy: ± 3 percent  
 Boom diameter: 32-43 mm (1¼-1½ in.)  
 Mast diameter: 38-63 mm (2½-2½ in.)

**G800S/G1000 SDX**

Medium/heavy-duty, for medium HF arrays.

Power consumption: 100 VA  
 450° rotation time: (S) 55s, (SDX) 43-93s  
 Rotation torque: 600-1100 kg-cm (43-79 ft-lbs)  
 Stationary torque: 4000 kg-cm (288 ft-lbs)  
 Max. vertical load: 200 kg (440 lbs)  
 Max. ant. surface area: 2 m<sup>2</sup>  
 Mast diameter: 38-63 mm (1½-2½ in.)

**G5400B/G5600B**

Azimuth-Elevation rotator combinations, for satellite earth station and other space communication antennas.

180° El, rotation time: 58 sec  
 360° Az, rotation time: 50 sec  
 El, rotation torque: 1.4 kg-m (102 ft-lbs)  
 Ax, rotation torque: 5400; 0.6 kg-m (44 ft-lbs)  
 5600; 0.7 kg-m (58 ft-lbs)  
 4 kg-m (292 ft-lbs)  
 Az, stationary torque: 5400; 2 kg-m (145 ft-lbs)  
 5600; 4 kg-m (292 ft-lbs)  
 200 kg (440 lbs)  
 Max vertical load: 200 kg (440 lbs)  
 Pointing accuracy: ±4 percent  
 Boom diameter: 32-43 mm (1¼ - 1½ in.)  
 Mast diameter: 38-63 mm (2-2½ in.)

**G1000S/G1000 SDX**

Heavy-duty for medium HF arrays.

Power consumption: 100 VA  
 450° rotation time: (S) 55s (SDX) 43-93s  
 Rotation torque: 600-1100 kg-cm (43-79 ft-lbs)  
 Stationary torque: 4000 kg-cm (288 ft-lbs)  
 Max. vertical load: 200 kg (440 lbs)  
 Max. ant. surface area: 2 m<sup>2</sup>  
 Mast diameter: 38-63 mm (1½-2½ in.)

**ACCESSORIES**

**Thrust Bearings**

GS050 48 mm I.D.  
 GS065 65 mm I.D.

**Mast Clamps**

C038 for G400 → G1000  
 GC048 for G2000

**Cables**

RC5W 5 way  
 RC6W 6 way  
 RC8W 8 way

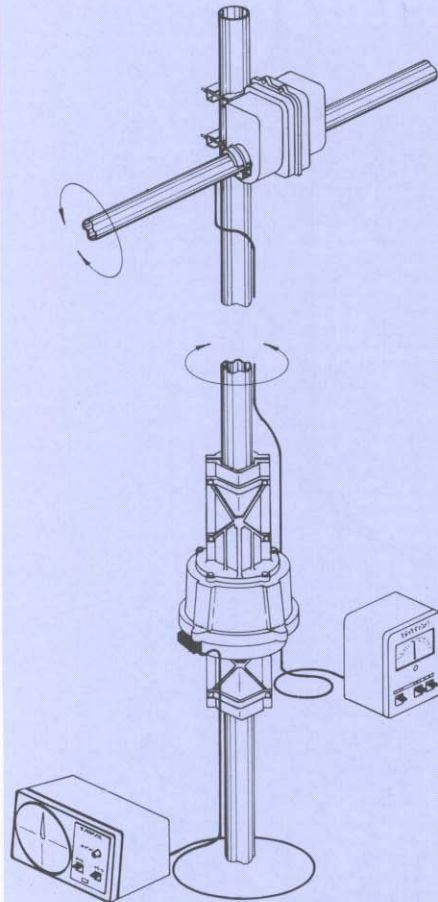

**Hy-Gain Heavy Duty Commercial Rotator Systems**

MODEL No.	ANTENNA WIND LOAD AREA CAPACITY (MOUNTED INSIDE TOWER)		MOTOR TURNING POWER-STALL TORQUE	BRAKE POWER-AMOUNT OF TORQUE TO HOLD ANTENNA		BRAKE CONSTRUCTION	BEARING ASSEMBLY	MOUNTING HARDWARE	CONTROL CABLE REQUIRED	SHIPPING WT.	
	Sq. ft.	Sq. m.		in. lbs.	N.m					in. lbs.	N.m
HDR 300	25	2.3	5000	7500	Solenoid Operated Locking Brake	Bronze Sleeve w/Roller Bearings Permanently Lubricated	Stainless Steel Bolts	7	55	25	
T <sup>2</sup> X	20	1.9	1000	9000	Electric Wedge	Triple Race 138 Ball Bearings	Clamp Plate: Stainless U-Bolts	8	28	12.7	
HAM IV	15	1.4	800	5000	Electric Wedge	Dual Race 98 Ball Bearings	Clamp Plate: Stainless U-Bolts	8	24	11	
CD45 II	8.5	.79	5.0	600	Disc Brake	Dual Race 98 Ball Bearings	Clamp Plate: Stainless U-Bolts	8	22	10	
AR 40	3.0	.28	1.5	350	Disc Brake	Dual Race 12 Ball Bearings	Plated Mast Clamps Steel U-Bolts	5	14	6.4	
AR 22XL	3.0	.28	1.5	350	Disc Brake	Dual Race 12 Ball Bearings	Plated Mast Clamps Steel U-Bolts	4	14.5	6.6	
R350I	45	4.2	9000	23000	Chain Drive	Collar/Roller Bearing	½" Plated Hardware	7	330	150	



South Midlands Communications

## Coaxial and Multicore Cables

### SMC S2U Coaxial Switch

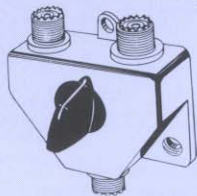

#### SPECIFICATIONS

Power Rating:	500 W PEP at 30 MHz
Impedance:	50 ohms
Insertion Loss:	Less than 0.5db
VSWR:	1.2 - 1 at 30 MHz.
Maximum Frequency:	500 MHz.
Contact Resistance:	Less than 20 milliohms.
Connectors:	20-230 or Type 'N'
Circuit:	1 pole 2 output positions/automatic grounding
Size:	80 x 70 x 40mm outside
Weight:	434 grams

### CX Series 12VDC Coaxial Relays

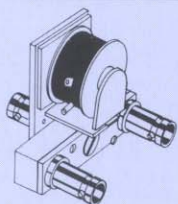

#### Models

CX540D - all BNC  
 CX530D - N2 x BNC  
 CX520D - all N

#### Many other models available

#### SPECIFICATIONS - ALL MODELS

Circuit Impedance:	50 Ohms
Operating Voltage (nominal):	12V DC
Operating Current:	160 mA
Power (At 30MHz):	1 kW PEP
Maximum Frequency:	2.5GHz
VSWR (1 GHz):	1.2 : 1
Isolation (1GHz):	50db
Insertion Loss (1.5GHz):	0.2 db
Contact Resistance (@ 5A DC):	30m Ohms
Operation Time (0-C + C-0):	20m Seconds
Operating Temperature:	-50° + 70° C
Weight:	200 gm ± 5%
Life Expectancy (at 30/min)	1,000,000

### Coaxial and Multicore Cables

SMC Ltd. carry a large stock of Coaxial, RF Twin Feeder and Multi-core cables, including Heliax type low-loss coax and some less popular 75 ohm cables, available in 100 or 500 metre drums. The following types are normally from stock. (Shorter lengths may also be supplied).

### Coaxial Cables - General Description

#### UR76, 43, 67, 39, 57

Supplied with black PVC sheath, polythene dielectric and plain copper inner and outer conductors.



#### HI00

Semi air spaced dielectric, foil and braid outer conductor, solid inner conductor, polythene black sheath and natural polythene tube and thread dielectric.

#### LDF2 & 4/50

Heliax, cellular foam dielectric, solid copper outer conductor, with helical indentation, copper coated aluminium inner conductor.



### RF Balanced Twin Cable

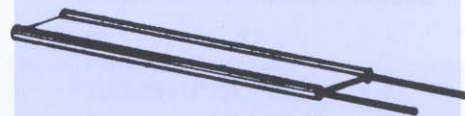

- 302 75 ohm light duty polythene black sheath, approximately 2.5mm x 4mm.
- 306 300 ohm flat twin ribbon light duty, natural polythene sheath 12mm x 2.5mm.

### Multicore Cables



- SMC RC5W 5 cores 7/0.25mm pure copper strand, individually PVC sheathed and PVC sheathed overall, cores laid up.
- SMC RC6W As RC5W but 6 cores of 7/0.25 PCW.
- SMC RC8W As RC6W but with 2 cores 7/0.44mm giving an 8 core cable with 2 larger CSA cores.

Cable Type	UR76 RG58	UR43	UR67 RG8U	HI00	LDF 2-50	LDF 4-50	UR70	UR39	UR57
Impedance (Group Ohms)	50	50	50	50	50	50	75	75	75
Sheath diameter in mm	5	5	11	10	11	16	6	8	11
Characteristic Impedance (Ohms)	50	52	52	50±4	50	50	72	69	75
Velocity Ratio %	66.5	66.6	66.6	84	88	88	69.9	66.6	66.6
Max. Volts (kV)	1.9	1.9	5	Not quoted	Not quoted	Not quoted	1.8	4.0	5.0
Capitance pF/m	29	30	30	80	82	82	21	23	20.6
Attenuation db/100m (MHz)									
1	1.7	1.4	.63	—	.326	.216	1.48	.79	.56
10	5.37	4.35	1.96	1.4	1.08	0.69	4.72	2.52	1.83
100	17.38	14.2	6.6	4.4	3.44	2.25	15.25	8.39	6.19
200	25.25	22.53	9.64	6.2	—	—	22.53	12.62	9.08
300	31.5	28.5	12.13	7.3	—	—	27.8	15.77	11.38
600	50.8	45.0	18.1	—	—	—	44.0	26.00	17.15
1000	72.6	54.5	24.63	13.3	11.5	7.68	53.4	34.5	23.4
2000	—	—	—	—	16.7	11.3	—	—	—
Minimum Bending Radius (cms)	2	2	12	15	9.5	12.5	4	7	12



South Midlands Communications

SMC carries a wide range of coaxial connectors in the BNC, N, UHF, C, TNC and other configurations. The connector range is complemented by a large selection of inter-series adaptors i.e. N to BNC, UHF to N, BNC to UHF etc.

Many other connectors available from stock please ask for details

## Coaxial Connectors

### BNC Series 50 OHM

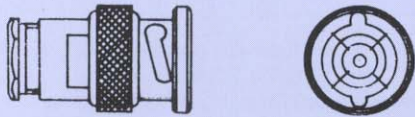

UG88 - To UR 76/43  
UG959 - To UR67/RG123

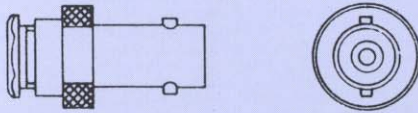

UG89 - To UR43/76

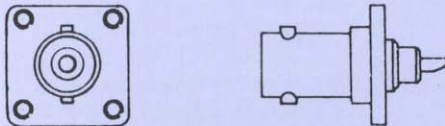

UG290 Panel Mount Socket

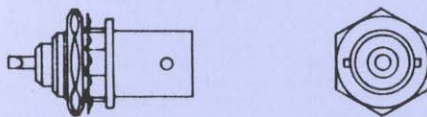

UG1094 Panel Socket  
Nut inner

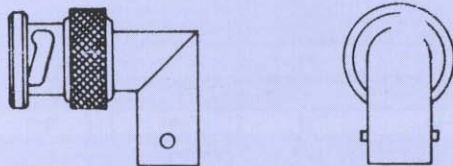

UG306 Male/Female Elbow



UG255 BNC Male/UHF Female

### UHF Series

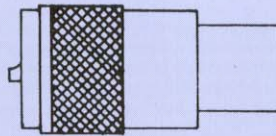

PL259 - UR67/RG123  
PL259A - UR76/43

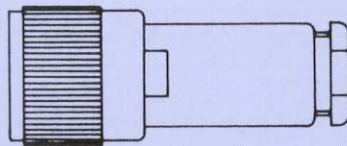

PL259B - High Grade  
Rubber Sleeve  
Type - UR67

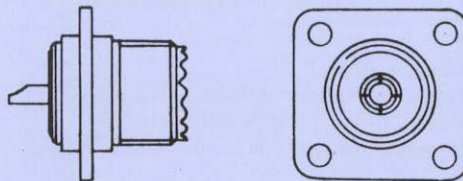

SO239 - Panel Mount Socket

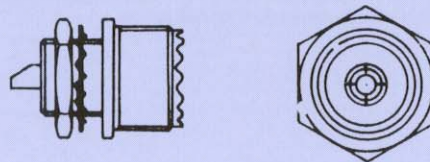

SO239 NI - Panel Mount Socket  
(Nut inner)  
SO239 NO - (Nut outer)

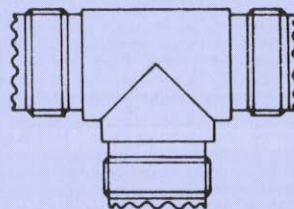

M358AF SO239 Tee adaptor

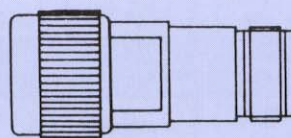

UG83 PL259 to N Female

### 'N' Series 50 OHM

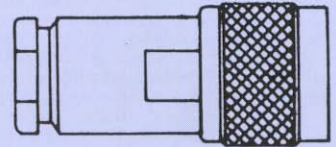

UG536 - To UR43/76  
UG21 - To UR67/RG213

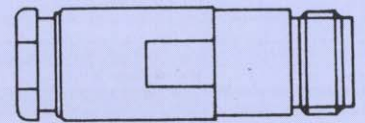

UG1052 - To UR43/76  
UG23 - To UR67/RG213

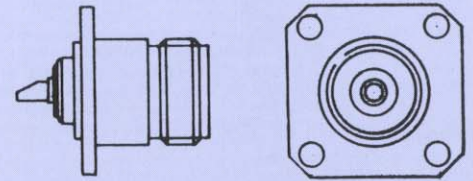

UG58 - Panel Socket

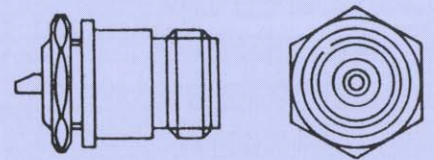

NSNI - Panel Socket  
Nut inner

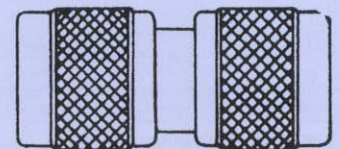

UG57 - Double Male Adaptor

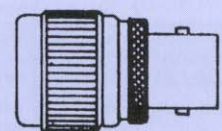

UG201 - N Male - BNC Female





South Midlands Communications

## Mast & Antenna Hardware



SMC MP 3/4 Guy Plates  
3 and 4 Way 2" I.D.



SMC MB 3/4 Guy Bands  
3 and 4 Way 1 1/2" to 2" O.D. Tube



SMC 59/15 Mast Couplers  
for 48 mm Dia. Tube

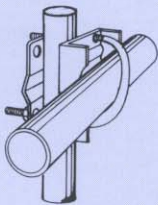

SMC 53 Light Duty Boom to  
Mast Clamps 2" O.D. to 1 1/4" O.D.

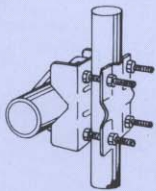

SMC 63 Medium Duty  
Boom/Mast Clamp  
2" O.D. to 1 1/4" O.D.

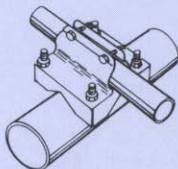

SMC 65 2" O.D. to  
1" O.D. Mast to Boom Clamp

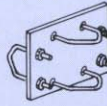

SMC CPI Cross Over Bracket  
2" x 2" O.D. Tube

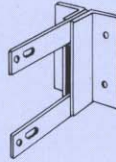

W6 Wall Bracket  
6" O.A. Stand Off 1/4" - 1/2" O.D. Tube

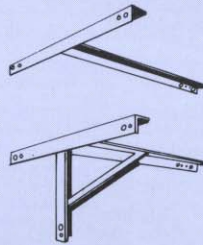

SMC W Series Wall Brackets  
supplied in pairs for  
12 to 24" Stand Off up to  
2" O.D. Tube

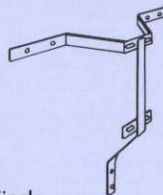

Heavy Duty Single  
Part Wall Brackets  
6" Stand Off up to  
2" O.D. Tube

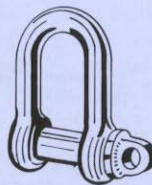

Galvanised Steel 'D' Shackles  
DS 6 - 6 mm      DS 11 - 11 mm  
DS 8 - 8 mm      DS 13 - 13 mm  
DS 10 - 10 mm    DS 15 - 15 mm



Galvanised Steel Bow Shackles  
BS 6 - 6 mm  
BS 8 - 8 mm  
BS 10 - 10 mm

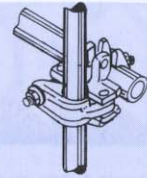

SMC Cast Cross Over Brackets  
Swivel and Fixed 48 mm O.D. Tube

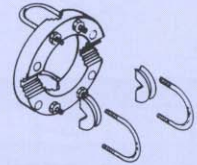

SMC/UA Heavy Duty  
Antenna Clamps Cast  
Alloy/Stainless Steel  
Up to 2" Dia. to 1 1/4"

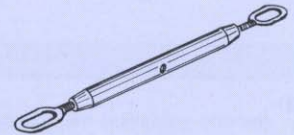

Galvanised Rigging Screws  
3/8", 1/2", 3/4" Dia.  
Fork or Oval Eye



Galvanised Wire Rope Grips  
CG 5 (5 mm)  
CG 6 (6 mm)  
CG 8 (8 mm)  
CG 10 (10 mm)



Galvanised Steel Thimbles  
THIM 30 - 1.25 ins O.A.  
THIM 38 - 1.5 ins O.A.  
THIM 44 - 1.25 ins O.A.  
THIM 51 - 2.0 ins O.A.  
Other Sizes on Request



Brass Line Taps (Tin Plated)  
HD 9 - Up to 3 mm Dia. Wire  
HD 10 - Up to 6 mm Dia. Wire  
HD 12 - Up to 7 mm Dia. Wire  
HD 12A - Up to 8 mm Dia. Wire



South Midlands Communications

### R.F. Insulators

SMC carry large stocks of porcelain, pyrex and polypropylene insulators for immediate delivery.

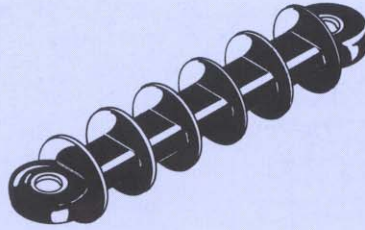

SMC P1 - Carbon Loaded Polypropylene.  
SWL 365 kgs 20/60 kv 8½" O.A. Length



Porcelain/Pyrex Egg Insulators  
1½", 2½", 2", 3⅛", 3¾", 4½" O.A. Length

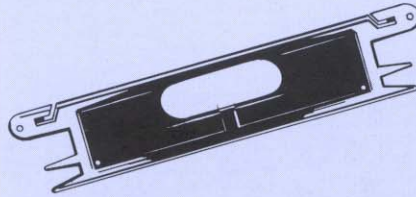

SMC I - II C/L Polypropylene  
Storage Spool 12" O.A. Length



Transmission Line Insulators  
4½" and 6" O.A. Height

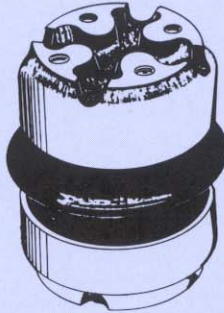

Base Insulators  
various sizes available 6" - 11" Height

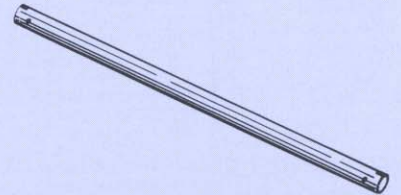

Porcelain/Nylatron  
Spacer Insulators  
various sizes 6" - 15" O.A. Length

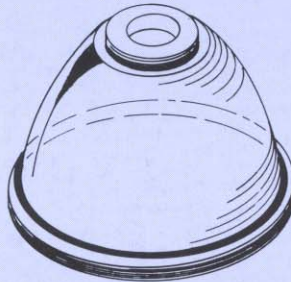

Pyrex Feed through  
"Bowl" Insulators 2¼" Dia.  
and 6" Dia., all C/W Mounting Hardware

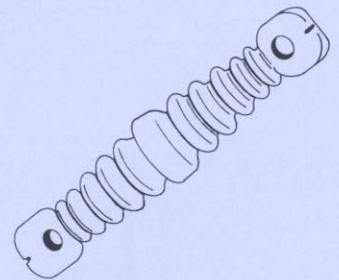

Porcelain/Pyrex Strain Insulators  
6", 7½", 12", O.A. Length



SMC P2 C/L Polypropylene  
SWC 45 kgs 2/5 kv 3" O.A. Length

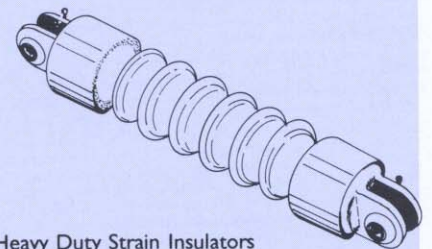

Heavy Duty Strain Insulators  
with Galvanised Steel End Caps  
9" O.A., 14½" O.A. Length

For full information refer to SMC Data Sheet 46



South Midlands Communications

## Steel & Copper Wires.

### Stock Ropes and Wires

#### Galvanised Steel, Copper, Pre-stretched Polyester and Polypropylene

SMC carry very large stocks of galvanised steel wire ropes in various constructions, pure copper and cadmium copper plain stranded wires for earthing and antenna construction, pre-stretched polyester and polypropylene ropes for lightweight stays and halyards, etc. Stainless steel rope is not a standard stock item, but can be supplied to order.

**1 x 19 Construction.** A stronger construction than most ropes of similar size, but much less flexible. It has a smooth finish and is used mainly for standing rigging and guy ropes.



1 x 19  
All Wire Strand

SPECIFICATIONS		
Nominal Dia. mm	Weight kg/100 metres	Breaking Loads 180 kgf/mm <sup>2</sup>
1.5	1.13	210
2.0	1.95	320
2.5	3.05	500
3.0	4.39	720
4.0	7.81	1285
5.0	12.2	2000
6.0	17.6	2876
7.0	23.9	3550
8.0	31.2	4641

**6 x 19 Construction.** A very good general purpose rope with a fibre main core giving good strength, with flexibility, and reasonably good resistance to abrasion and crushing. Used for guys, running rigging, hoists and winches, etc.



6 x 19 with  
Fibre Main Core

SPECIFICATIONS		
Nominal Dia. mm	Weight kg/100 metres	Breaking Loads 180 kgf/mm <sup>2</sup>
3.0	3.02	498
4.0	5.37	885
5.0	8.40	1380
6.0	12.1	1990
7.0	16.5	2710
8.0	21.5	3540
9.0	27.2	4480
10.0	33.6	5530

**7 x 7 Construction.** Seven strands of steel cores (no fibre cores) makes 7 x 7 a good strength rope, with maximum resistance to abrasion, and crushing. Semi-flexible, used for standing rigging and guy ropes.



7 x 7 Construction  
(No Fibre core)

SPECIFICATIONS		
Nominal Dia. mm	Weight kg/100 metres	Breaking Loads 180 kgf/mm <sup>2</sup>
3.0	3.43	581
4.0	6.10	1033
5.0	9.54	1620
6.0	13.75	2322
7.0	18.7	3164
8.0	24.4	4136
9.0	30.91	5227
10.0	38.10	6458

#### Galvanised mild steel wire strand 7 x 1.



A cost effective simple soft-strand for use with small masts and low-stress catineries. 7/18 gauge and 7/14 gauge from stock.

#### Cadmium Copper Antenna Strand (Hard Drawn)



Available in various sizes as shown, all hard drawn strands have a cadmium content. This increases the tensile strength and the stranded construction increases flexibility.

#### Seven stranded wires hard drawn cadmium copper



SPECIFICATIONS			
Type	B.S. kilos	O.A. dia mm	Weight kg/100 metres
7/0.737mm(7/0.29")	186	2.12	2.68
7/0.914mm(7/0.36")	287	2.72	4.12
7/1.118mm(7/0.44")	428	3.30	6.16
7/1.600mm(7/0.63")	880	4.85	12.5

#### Single stranded wires hard drawn cadmium copper



14 SWG (2.02mm)	209	2.02	2.82
-----------------	-----	------	------

#### Soft plain copper (earthing strand)



7/0.737 available in drums up to 7,000 metres	2.12	2.68
---	------	------

#### Three-strand Pre-stretched Polyester Ropes

A very low stretch rope ideal for mast guys. Unaffected by extremes of temperatures, moisture and U.V.. Approximate stretch characteristic when new, 6% at 50% of guaranteed strength.



SPECIFICATIONS	
Guaranteed Strengths:	
Overall diameter (mm)	G.S. in kg
3"	275
4"	400
6"	750
8"	1250
10	1750
12	2400
14	3400

\*Normally available from stock

#### Polypropylene Rope

A cost effective purpose rope, for use in low duty cycles and low stress situations.



SPECIFICATIONS	
O.A. Diameter mm	Guaranteed Strength kg
4	240
6	550
8	875
10	1375
12	1900
14	2600
16	3300

Stretch factor at 50% G.S. = 30%. U.V. stabilized but not unaffected.



SMC House

**South Midlands Communications Limited**

S.M. House, School Close

Chandlers Ford Industrial Estate

Eastleigh, Hampshire, SO53 4BY

United Kingdom

**Telephone: +44 (0)1703 255111**

Facsimile: +44 (0)1703 263507

E-mail: [sales@smc-comms.com](mailto:sales@smc-comms.com)

Web site: <http://www.smc-comms.com>