



the hallicrafters co.
MANUFACTURERS OF RADIO, TELEVISION AND ELECTRONIC EQUIPMENT, CHICAGO 24, U. S. A.



092-104533

Figure 1. Hallicrafters Model S-108.

SECTION I GENERAL DESCRIPTION

1-1. INTRODUCTION.

Your new Hallicrafters Model S-108 is a precision built, highly sensitive, communications receiver providing complete coverage in the frequency range of 538 kilocycles to 34 megacycles. Eight tubes, including one rectifier, are employed in the latest superheterodyne circuit and provision is made for the reception of AM or CW signals over the entire tuning range.

For ease and flexibility of operation, two tuning dials are provided. The circular dial provides the general frequency coverage, while the slide rule type dial (the bandspread dial) is specifically calibrated for the 80, 40, 20, 15 and 10 meter bands.

For increased selectivity, an automatic noise limiter circuit can be switched into operation to provide a means of receiving many signals that would be lost in background noise with ordinary receiving equipment.

Other special features include full range TONE

control, SENSITIVITY control with provision for the optional use of AVC, a RECEIVE-STANDBY switch that permits silencing the receiver while maintaining its ready for instant use, without waiting for the tubes to warm up, and a headphone (PHONES) jack mounted on the front panel. Also included is a built-in Alnico V permanent magnet speaker for assured lifelike reproduction.

IMPORTANT

Your careful attention is especially invited to the "INSTALLATION" and "OPERATION" instructions. They have been provided to insure the satisfaction you have a right to expect from any Hallicrafters "Precision Built" product. Your receiver has an unusually high degree of sensitivity necessary to receive weak and distant stations. Careless operation of a high sensitivity receiver may result in excess noise or background hiss. These undesirable effects can be held to a minimum by careful adjustment of the SENSITIVITY, TUNING, and TONE controls as well as the proper selection and arrangement of the antenna.

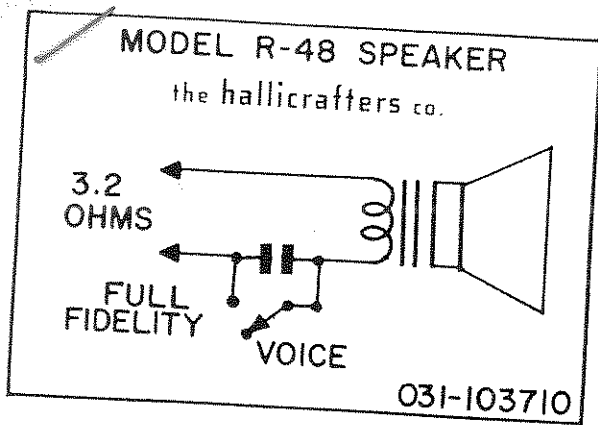

RS INSTALLATION SHEET

FOR

HALLICRAFTERS MODEL R-48 SPEAKER

The Model R-48 speaker is designed for use with Hallicrafters receivers which require the use of an external speaker. However, the speaker may be used with any receiver or amplifier system having a 3.2 ohm nominal output impedance and an output not exceeding five watts of power.

A specially designed 5 1/2 x 7 1/2 inch, permanent magnet, dynamic type speaker is employed in the speaker cabinet. Included is a six foot cable with terminal lugs to facilitate connecting to a receiver. To connect the speaker, simply attach the terminal lugs of the speaker cable to the "G" and 3.2 ohm output impedance terminal of the receiver or amplifier.

The "VOICE-FULL FIDELITY" switch, located at the upper right corner at the rear of the speaker cabinet, provides a choice of two different frequency responses. With the switch set at "VOICE", the voice frequency range is accentuated; at "FULL FIDELITY", the entire audio frequency range is reproduced.

Form No. 094-902143

ADDENDUM
TO
MODEL S-108

After the Instruction Manual for the S-108 was published, various electric modifications were made to improve performance. See illustration below for wiring modification of the audio output stage. It is suggested that the following corrections be noted in the Service Parts List at this time.

1. Change capacitor C56 to read ".01 mfd. , 1400V. ; cer. disc, 047-200752."
2. Add capacitor C65, 390 mmf. , 10%, 500V. ; Mica, 470-213391.
3. Add resistor R69, 470K ohm, 451-252474.
4. Add resistor R70, 47 ohm, 451-252470.
5. Change T4, Transformer, Audio Output to read 055-100415.
6. Change Shaft, Drive (BANDSPREAD) to read 074-202274
7. Change Shaft, Drive (MAIN TUNING) to read 074-202274

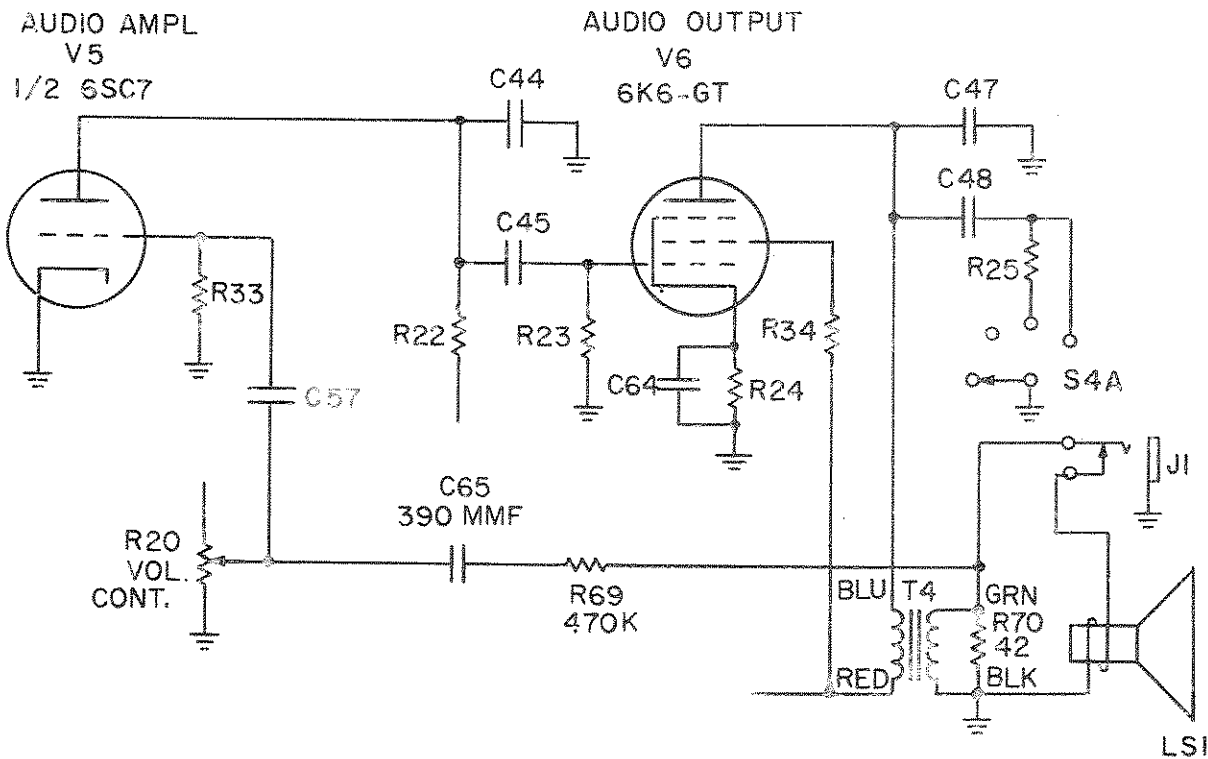

SECTION II INSTALLATION

2-1. UNPACKING.

After unpacking the receiver, examine it closely for damage which may have occurred in transit. Should any sign of damage be apparent, file a claim immediately with the carrier stating the extent of damage. Carefully check all shipping labels and tags for instructions before removing or destroying them.

2-2. LOCATION.

The receiver is equipped with rubber mounting feet for table or shelf mounting. When locating the receiver, avoid excessively warm locations such as those near radiators and heating vents. Allow at least one inch of clearance between the back of the receiver and the wall for proper ventilation.

2-3. POWER SOURCE.

The S-108 receiver is designed to operate from a 105-125 volt, 50-60 cycle AC power source. Power consumption is 75 watts.

IMPORTANT

If in doubt about your power source, contact your local power company prior to inserting the power cord into an AC power outlet. Plugging the power cord into the wrong power source may cause extensive damage to the unit, requiring costly repairs.

2-4. ANTENNAS.

The RF input of the receiver is designed for operation from either a single-wire antenna, or a half-wave doublet or other tuned antenna with transmission line impedances from 52 to 600 ohms. Antenna connections are made to a three-terminal strip at the rear of the receiver marked "A1", "A2", and "G".

2-4-1. SINGLE WIRE ANTENNA.

The simplest antenna and one which will provide satisfactory results throughout the entire tuning range is a conventional single-wire antenna. In most localities, good results can be obtained with just the 15-

foot length of antenna wire supplied with the receiver. Simply attach one end of this wire to terminal "A1", connect the jumper link between terminals "A2" and "G", and then run the wire about the room in any convenient manner. (See Fig. 2.) If the receiver is operated in a steel constructed building or where receiving conditions are exceptionally poor, an outside antenna should be erected as high as possible and kept free from surrounding objects. In some locations, reception may be improved by connecting a ground wire (ordinary copper wire) from terminal "G" to a cold water pipe or outside ground rod. While the use of an outside ground rod installed in accordance with Insurance Underwriter's Laboratories requirements is adequate protection against lightning, we strongly recommend an additional connection to the nearest cold water pipe to eliminate any shock hazard.

2-4-2. HALF-WAVE DOUBLET ANTENNA.

For top performance, especially on the shortwave and amateur bands, the use of a half-wave doublet or other type of antenna employing a 52 to 600-ohm transmission line is recommended. A typical doublet antenna installation is shown in Fig. 3. The doublet antenna should be cut to the proper length for the most used frequency or band of frequencies. The overall length in feet of a doublet antenna is determined by the following formula:

$$\text{Length in feet} = \frac{468}{\text{Frequency in megacycles}}$$

When erecting the doublet antenna, it should be remembered that it displays directional properties broadside to its length and should be so oriented with respect to a desired station for maximum signal pickup.

The doublet antenna may be fed with either a balanced or unbalanced transmission line. When a balanced transmission line such as "twin-lead" or a twisted pair is used, the transmission line connects to terminals "A1" and "A2", and the jumper link between terminals "A2" and "G" is disconnected. When using an unbalanced transmission line such as coaxial cable, the inner conductor connects to terminal "A1", the outer braid connects to terminal "A2", and the jumper

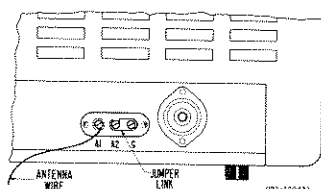

Figure 2. Single Wire Antenna.

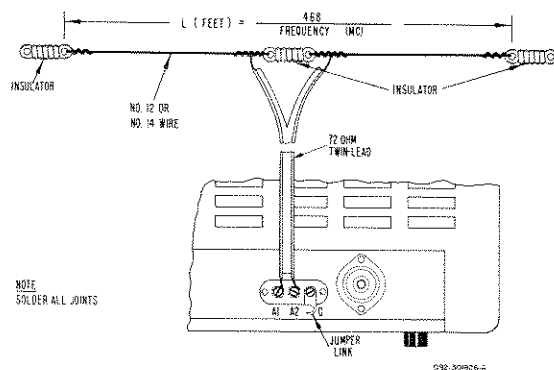
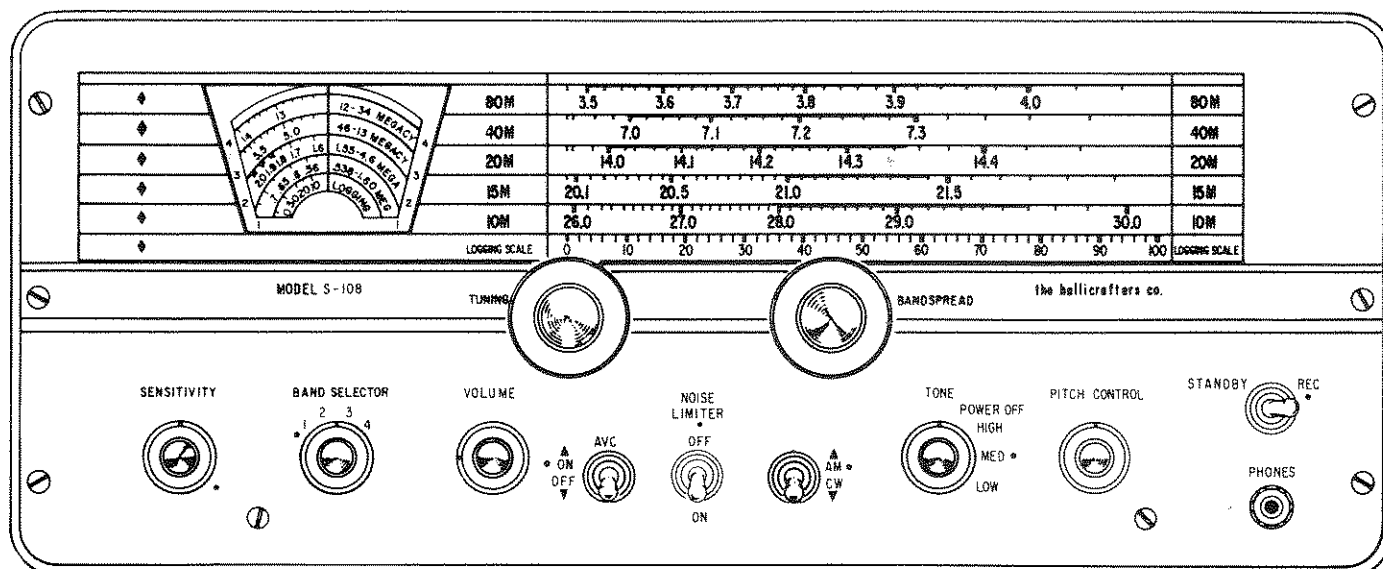

Figure 3. Doublet Antenna Using Twin-Lead Transmission Line.



092-304539

Figure 4. Receiver Operating Controls.

link connects between terminals "A2" and "G". A ground wire may improve reception when using an unbalanced transmission line.

The doublet antenna provides optimum performance only at the frequency for which it is cut. Therefore, it may be desirable for reception on frequencies remote from the antenna frequency to utilize the antenna as a single wiretype. This is accomplished by connecting the two transmission line leads together and connecting them to terminal "A1". The jumper link in this case should be connected between terminals "A2" and "G".

In an installation where the receiver is used in conjunction with a transmitter, it may be advantageous to use the same antenna for receiving as for transmitting. This is especially true when a directive antenna is used since the directive effects and power gain of the transmitting antenna are the same for receiving as for transmitting. Switching of the antenna from the

transmitter to the receiver may be accomplished with a double-pole, double-throw antenna changeover relay or knife switch connected in the antenna leads.

For further information regarding antennas, refer to the "Radio Amateur's Handbook" or the "A. R. R. L. Antenna Book", both published by the American Radio Relay League, West Hartford, Conn., U. S. A.

2-5. HEADPHONES

The headphone jack, marked "PHONES", is located on the front panel of the receiver and is wired so that the speaker is automatically disabled when the headphones are plugged in. The headphone output impedance is not critical and any commercial headphones may be used, including crystal types, as no direct current flows in the headphone circuit. For maximum headphone output, the use of high-impedance magnetic (5000 ohms) or crystal phones is recommended.

SECTION III OPERATION

3-1. GENERAL.

Each control of your receiver performs a definite function which contributes to its outstanding reception capabilities. Full appreciation of the receiver is to be expected only after you have become familiar with each of the controls and the effect each control has on the performance of the receiver.

As a special convenience for those not yet familiar with the full advantages of the various controls, the control settings commonly used for broadcast reception are marked with a dot.

3-2. SENSITIVITY CONTROL.

The SENSITIVITY control is used in combination with the VOLUME control to regulate the level of receiver output.

The setting of the SENSITIVITY control determines the ability of the receiver to pick up weak or distant stations. This control is normally set at the extreme clockwise position, when receiving AM signals, and at some other position when receiving CW signals. Maximum sensitivity may be used while tuning across the frequency range, but if the station se-

lected has too strong a signal, excessive background hiss or distortion may be present. If this undesirable effect is produced, it can be greatly reduced by turning the SENSITIVITY control in the counterclockwise direction to a slightly lower setting. If, after reducing the sensitivity, more volume is needed, advance the VOLUME control. When receiving CW signals, a setting of the SENSITIVITY control that is too high will be evidenced by "thumping" (overloading).

3-3. BAND SELECTOR CONTROL.

The BAND SELECTOR control should be set for the band you wish to tune. The four positions of this control correspond to the band numbers at either side of the main tuning dial.

3-4. AM-CW SWITCH.

Set this switch at "AM" to listen to voice broadcasts. Set it at "CW" only, if you wish to hear code signals.

3-5. AVC SWITCH.

The AVC switch, when set at "ON", places the automatic volume control circuit in operation to maintain a uniform volume level, regardless of variations in signal strength at the antenna. For AM reception, this switch should normally be set at "ON". For CW reception, this switch should be set at "OFF".

3-6. NOISE LIMITER SWITCH.

This switch should normally be set at "OFF". If severe electrical disturbances, ignition noise, or other types of pulse-type noise interfere with reception, set the switch at "ON" to place the Automatic Noise Limiter circuit in operation.

3-7. VOLUME CONTROL.

This control is used to regulate receiver volume. Clockwise rotation increases volume; counterclockwise rotation decreases volume.

3-8. PITCH CONTROL.

This control is used to vary the pitch of code signals, and should be set for the tone most pleasing to the operator. For this control to have any effect, the AM-CW switch must be set at "CW".

3-9. TONE CONTROL.

The TONE control is a combination receiver ON-OFF switch and 3-position TONE control. In the "PWR OFF" position, the receiver is inoperative. To turn the receiver on, simply rotate the control to any of its three remaining positions. For AM reception, set the control for the desired tonal quality. For CW reception, set the control at "LOW".

3-10. TUNING AND BANDSPREAD CONTROLS.

The TUNING and BANDSPREAD controls are used in conjunction with one another to tune in the desired signal. Wide tuning is performed with the TUNING control and fine tuning with the BANDSPREAD control.

A. MAIN TUNING DIAL.

The main tuning or left-hand dial is operated by the TUNING control. This dial has four calibrated scales, one for each of the four frequency bands covered by the receiver. It also contains a 20 division logging scale for accurately logging and relocating stations of special interest. The main tuning dial should be set for the desired station frequency after the BANDSPREAD control has been set fully clockwise (minimum bandspread tuning capacity).

IMPORTANT

The receiver frequency readings or calibration on the main tuning dial will be correct only if the BANDSPREAD control has been set fully clockwise. If it is set at any other setting, the additional bandspread capacity added to the main tuning capacity will throw off the main tuning dial calibration, because the receiver has been calibrated with the bandspread tuning capacitor set at minimum.

The dial settings for the 80, 40, 20, 15, and 10 meter amateur bands are indicated on the main tuning dial by white dots. When tuning the amateur bands with the bandspread dial, the main tuning dial must be set at the dot corresponding to the desired amateur band. The 160 meter amateur band is indicated on the dial by three short double-weight lines.

B. BANDSPREAD DIAL.

The bandspread or right-hand dial is operated by the BANDSPREAD control. This dial contains five scales calibrated for the 80, 40, 20, 15, and 10 meter amateur bands. These five scales are calibrated to read receiver frequency directly when the main tuning dial has been set to the index dot of the desired amateur band. For convenience in tuning, the AM phone bands are indicated on the bandspread dial by double-weight lines.

In addition to its use on the amateur bands, the bandspread dial may also be utilized as a fine tuning adjustment over any portion of the receiver tuning range. Two methods of fine tuning are described below.

- (1). The first method of fine tuning is used when it is desired to tune in a single signal with precision accuracy. First the BANDSPREAD control is set a few degrees from its full clockwise position, then the desired signal is located with the TUNING control, and finally the signal is accurately tuned in by "rocking" the BANDSPREAD control (turning it slightly to the left and right) until the signal is loudest and clearest.
- (2). The second method of fine tuning is used when it is desired to tune through a group of signals. With the BANDSPREAD control set fully clockwise, adjust the

TUNING control to tune in the highest-frequency signal in the group. The other signals can then be heard by slowly turning the BANDSPREAD control in a counterclockwise direction.

3-11. STANDBY-RECEIVE SWITCH.

This switch, normally set at "REC", permits you to silence the receiver without turning it off. To silence the receiver, set the switch at "STANDBY". In this position, the RF and IF stages are cut off, but the tube heaters remain at operating temperature for instant use. To resume reception at any time, simply return the switch to the "REC" position.

3-12. SERVICE OR OPERATION QUESTIONS.

For any further information regarding operation or servicing of your receiver, contact your Hallicrafters dealer. The Hallicrafters Co. maintains an extensive system of authorized service centers where any required service will be performed promptly and efficiently at a nominal charge. All Hallicrafters

Authorized Service Centers display the sign shown below. For the location of the one nearest you, consult your dealer or telephone directory.

The Hallicrafters Co. reserves the privilege of making revisions in current production of equipment and assumes no obligation to incorporate these revisions in earlier models.



SECTION IV SERVICE DATA

4-1. TECHNICAL SPECIFICATIONS.

TUBES Eight including rectifier
 SPEAKER..... 5 inch PM; 3.2 ohm voice coil
 HEADPHONE OUTPUT High impedance
 (See Par. 2-5)
 ANTENNA INPUT For single wire or 52-600 ohm
 balanced or unbalanced line.
 POWER SOURCE 105-125 volts, 50-60 cycles AC
 POWER CONSUMPTION..... 75 watts
 RECEPTION..... AM and CW
 INTERMEDIATE FREQUENCY 455 KC
 AUDIO OUTPUT IMPEDANCE..... Matches 3.2 ohms

DIMENSIONS.. 18 3/4" wide x 10 1/4" deep x 8" high
 WEIGHT, Net..... 28 lbs., 4 oz.
 WEIGHT, Shipping 32 lbs.

FREQUENCY COVERAGE

Band	Frequency Range	Calibrated Band Spread
1	.538 - 1.6 MC	-
2	1.55 - 4.6 MC	80M
3	4.6 - 13.0 MC	40M
4	12.0 - 34.0 MC	20, 15, and 10M

4-2. TUBE AND DIAL LAMP REPLACEMENT.

To gain access to the tubes and dial lamps, see

"CHASSIS REMOVAL". The tube locations, as well as their functions, are shown in Fig. 6.

4-3. CHASSIS REMOVAL.

The chassis and front panel assembly are removable from the cabinet as a unit by removing the three screws at each side of the front panel and the five screws on the underside of the cabinet. When removing the chassis from the cabinet, care should be taken not to damage or disturb any of the variable adjustments.

4-4. DIAL CORD RESTRINGING.

To restring the TUNING or BANDSPREAD dials, first remove the chassis from the cabinet. See "CHASSIS REMOVAL". Remove the front panel from the cabinet by removing the control knobs, the four toggle switch and PHONES jack decorative nuts, and the two screws at the bottom of the front panel. Then remove the main tuning dial to gain access to the drive pulleys. For stringing details, refer to Fig. 5. Note that stringing is done with the TUNING and BANDSPREAD gangs fully meshed. After stringing is completed, cut off the excess dial cord and apply a drop of quick drying cement to the knots.

With the TUNING and BANDSPREAD gangs fully meshed, replace the dial so that the index marks at the low frequency end of the dial are in line with the hairline on the dial window.

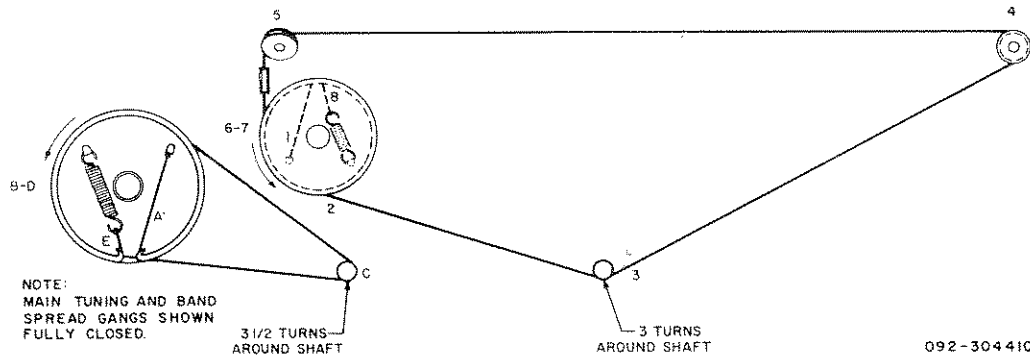

Figure 5. Dial Cord Stringing Diagram.

SECTION V ALIGNMENT

5-1. GENERAL.

This receiver has been carefully aligned at the factory by specially trained personnel using precision equipment. Alignment of the receiver should not be attempted until all other possible causes of faulty operation have been investigated. Alignment should not be required unless the receiver has been tampered with or component parts have been replaced in the RF or IF stages. Alignment should only be made by persons familiar with communications receivers and experienced in their alignment. Refer to Figs. 7 and 8 for location of all alignment adjustments.

5-2. EQUIPMENT REQUIRED.

1. Signal generator covering 455 KC to 28 MC.
2. Output meter (or AC scale of VTVM). Connect meter from 3.2 ohm speaker terminal to ground.

3. Non-metallic alignment tool.
4. Standard RTMA dummy antenna shown in Fig. 8.
5. 0.02 mfd. capacitor.

5-3. INITIAL CONTROL SETTINGS.

BAND SELECTOR As indicated in chart.
 SENSITIVITY AND VOLUME Maximum.
 NOISE LIMITER AND AVC OFF
 STANDBY-RECEIVE RECEIVE
 TONE HIGH
 AM-CW AM
 TUNING Fully clockwise
 BANDSPREAD Extreme right position.

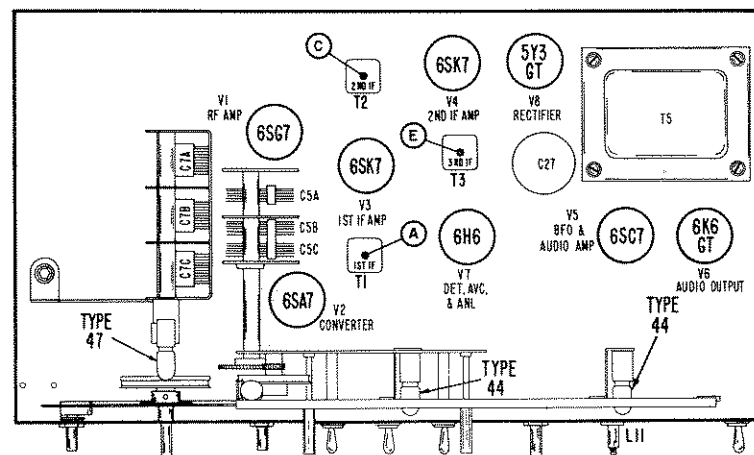

Figure 6. Top View Chassis Tube Locations and Alignment Points.

5-4. ALIGNMENT PROCEDURE.

The local oscillator frequency is higher than the signal frequency on bands 1, 2, and 3, and lower than the signal frequency on band 4.
 RF alignment can be made with chassis in cabinet. Holes in bottom of cabinet provide access to all RF adjustments.
 For IF alignment, remove chassis from cabinet. Use just enough generator output to maintain a 500 milliwatt reading on the output meter.

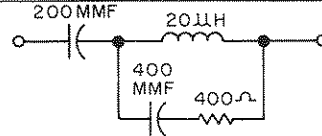

Figure 8. RTMA Dummy Antenna.

IF ALIGNMENT				
Step	Signal Generator Connections	Generator & Receiver Frequency	Band Selector Setting	Adjust for Maximum Output
1	High side thru .02 mfd capacitor to pin 8 of 6SA7 converter tube (V-2); low side to chassis.	Gen. - 455 KC Rec. - 1.0 MC	1	Top and bottom slugs of T1 (1st IF), T2 (2nd IF), and T3 (3rd IF).
2	Same as Step 1.	Gen. - 455 KC (Unmod.) Rec. - 1.0 MC	1	*Remove PITCH CONTROL knob and set AM-CW switch at "CW". Using speaker as indicator, adjust L11 (BFO) for "zero beat". After completing the adjustment replace knob with indicator line in top center position and return AM-CW switch to "AM".
*After removing the PITCH CONTROL knob (with the knob indicator line in the top center position), loosen set screw attaching the sleeve shaft to the BFO iron core adjustment screw. The position of the flat on the sleeve shaft must be maintained while adjusting for a zero beat.				
RF ALIGNMENT				
3	High side thru RTMA dummy antenna (Fig. 4) to antenna terminal "A1"; low side to "A2". Jumper between "A2" and "G".	Rec. - 28.0 MC	4	C19 (osc. trimmer) C12 (mixer trimmer) C1 (antenna trimmer)
		Rec. - 14.0 MC	4	L7 (osc. slug) L4 (mixer slug) L1 (antenna slug)
4	Same as Step 3.	Rec. - 11.0 MC	3	C20 (osc. trimmer) C13 (mixer trimmer) C2 (antenna trimmer)
		Rec. - 5.1 MC	3	L8 (osc. slug) L5 (mixer slug) L2 (antenna slug)
5	Same as Step 3.	Rec. - 4.0 MC	2	C21 (osc. trimmer) C14 (mixer trimmer) C3 (antenna trimmer)
		Rec. - 1.8 MC	2	L9 (osc. slug)
6	Same as Step 3.	Rec. - 1.4 MC	1	C22 (osc. trimmer) C15 (mixer trimmer) C4 (antenna trimmer)
		Rec. - .6 MC	1	C25 (osc. padder)

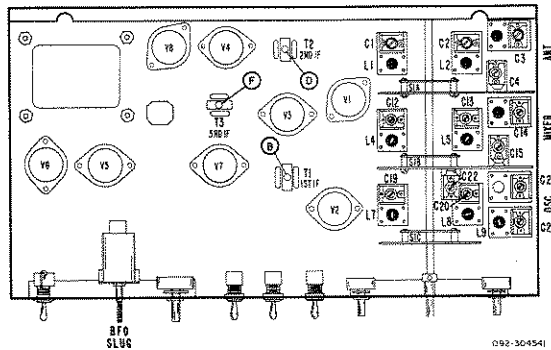
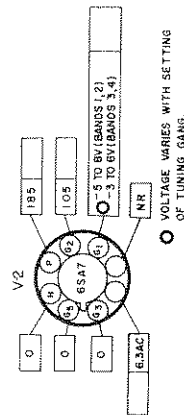
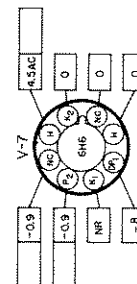
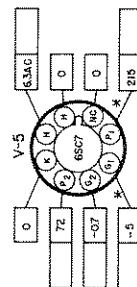
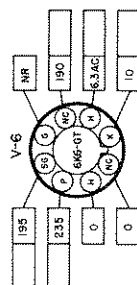
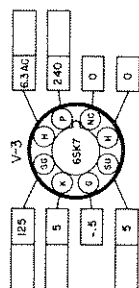
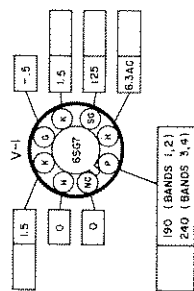
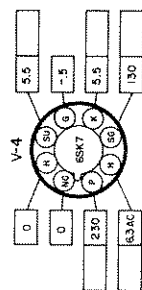
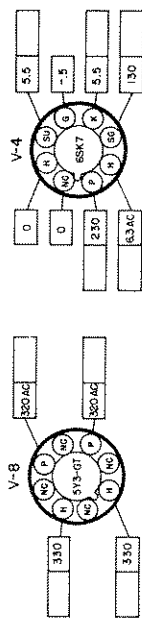

Figure 7. Bottom View Chassis Tube Locations and Alignment Points.

SERVICE PARTS LIST

Schematic Symbol	Description	Hallicrafters Part Number	Schematic Symbol	Description	Hallicrafters Part Number	Schematic Symbol	Description	Hallicrafters Part Number
CAPACITORS			RESISTORS (CON'T)			TUBES AND DIAL LAMPS		
C1, 12	4-80 mmf.; Mica Trimmer	044-100395	R20	500K ohm, variable; VOLUME Control	025-201748	V1	6SG7; RF Amplifier	090-901181
C2, 13	3-30 mmf.; Mica Trimmer	044-100396	R21	150 ohm, 20%	451-253151	V2	6SA7; Converter	090-901180
C3, 14	1.5-15 mmf.; Mica Trimmer	044-200147	R22, 60	270K ohm	451-252274	V3, 4	6SK7; 1st and 2nd IF Amplifiers	090-901233
C4, 15, 22	2-20 mmf.; Mica Trimmer	044-100191	R23	470K ohm, 20%	451-253474	V5	6SC7; BFO and Audio Amplifier	090-900874
C5A, B, C	Variable Capacitor, 3 section; Bandsread Tuning (pulley included)	048-300449	R24	270 ohm, 1 Watt	451-352271	V6	6K6GT; Audio Output	090-900856
C7A, B, C	Variable Capacitor, 3 section; Main Tuning (pulley included)	048-100448	R25	15K ohm, 20%, 1 Watt	451-353153	V7	6H6; Detector, ANL and AVC	090-900847
C8, 32, 35, 58, 60	.05 mfd., +20, -10%, 200V.; Tubular	499-012503	R27, 66	47K ohm, 1 Watt	451-352473	V8	5Y3GT; Rectifier	090-901111
C9, 28	.05 mfd., +20, -10%, 600V.; Tubular	499-032503	R28	22K ohm, 20%	451-253223	LM1, 2	Lamp, Dial; Type 44	039-100003
C11	2.2 mmf.; Neutralizing	047-100160-04	R30, 68	10 ohm, 20%	451-253100	LM3	Lamp, Dial; Type 47	039-100004
C16	390 mmf.; 10%, 500V.; Mica	470-213391	R32	1.5K ohm, 10 Watt, W.W.	453-062152	KNOBBS		
C17, 53	0.01 mfd., +20, -10%, 600V.; Tubular	499-032102	R33	15 megohm, 20%	451-253156	Knob, BAND SELECTOR and PITCH CONTROL		
C18	150 mmf., 5%, 500V.; Mica	470-222151	R34	10K ohm, 20%	451-253103			
C19	4-70 mmf.; Mica Trimmer	044-100149	R35	27 ohm	451-252270	MISCELLANEOUS PARTS		
C20, 21	2-30 mmf.; Mica Trimmer	044-100148	R62	560K ohm	451-252564	Cabinet Weld Assy.		
C23	3300 mmf., 5%, 500V.; Mica	470-422332	R63	6.8 ohm, 1 Watt	451-352068			
C24	1500 mmf., 2%, 500V.; Mica	470-421152	R64	330 ohm	451-252331	Dial Cord		
C25	320-520 mmf.; Mica Padder	044-100394	R67	330K ohm	451-252334			
C27A, B, C	30-10-10 mfd., 450V.; Electrolytic	045-100062	*All resistors are 10%, 1/2 watt, carbon type unless otherwise specified.			Dial Plate Weld Assy.		
C29, 33	220 mmf., 10%, 500V.; Mica	470-213221	**COILS AND TRANSFORMERS					
C31, 43	.02 mfd., +20, -10%; 600V.; Tubular	499-012203	L1	Coil, Antenna (Band 4); Inc. C1	051-201907	Foot, Rubber		
C38	2 mmf.; Wire Gimmick	-----	L2	Coil, Antenna (Band 3); Inc. C2	051-201908			
C39	.1 mfd., +20, -10%, 600V.; Tubular	499-032104	L3	Coil, Antenna (Bands 1 and 2)	051-201909	Line Cord		
C41, 42	47 mmf., 20%, 500V.; Mica	470-214470	L4	Coil, Mixer (Band 4); Inc. C12	051-201905			
C44, 55	270 mmf., 10%, 500V.; Mica	470-213271	L5	Coil, Mixer (Band 3); Inc. C13	051-201906	Line Cord Lock, Female		
C45, 48, 52, 63	.02 mfd., +20, -10%, 600V.; Tubular	499-032203	L6	Coil, Mixer (Bands 1 and 2); Inc. C14	051-201904			
C47	.0022 mfd., +20, -10%, 1000V.; Tubular	499-044222	L7	Coil, Oscillator (Band 4); Inc. C19	051-201900	Shaft, Drive (BAND-SPREAD)		
C54	470 mmf., 20%, 500V.; Mica	470-212471	L8	Coil, Oscillator (Band 3); Inc. C20	051-201899			
C56	.01 mfd., 20%, 600V.; Tubular	499-034103	L9	Coil, Oscillator (Band 2); Inc. C21	051-201898	Spring		
C57	.001 mfd., 20%, 500V.; Mica	470-314102	L10	Coil, Oscillator (Band 1); Inc. C22	051-201897			
C61	.25 mfd., +20, -10%, 200V.; Tubular	499-012254	L11	Coil, BFO	054-200051	TS1		
C64	10 mfd., 25V.; Electrolytic	045-100121	T1, 2	Transformer, 1st and 2nd IF	050-300243			
*RESISTORS			T3	Transformer, Audio Output	055-200093	Transformer, Power		
R1, 61	1 megohm, 20%	451-253105	T4	Transformer, Audio Output	055-200093			
R2	120 ohm	451-252121	T5	Transformer, Power	052-100209	SWITCHES		
R3	10K ohm, variable; SENSITIVITY control	025-201750	S1A	Wafer Switch, Antenna	060-200389	S1B Wafer Switch, Mixer		
R4, 31	22 ohm, 20%	451-253220	S1C	Wafer Switch, Oscillator	062-200044			
R5	39K ohm, 1 Watt	451-352393	Switch, SPST Toggle; STANDBY-REC, NOISE LIMITER, AVC, and AM-CW			060-100138		
R6, 26	6.8K ohm, 1 Watt	451-352682						
R7	22K ohm	451-252223	Shaft, Bandswitch And Index Plate			060-200392		
R8	10K ohm, 2 Watt	451-652103						
R9, 11	470 ohm	451-252471	PL1 Line Cord and Plug Assy.			087-100078		
R10	24K ohm, 5%, 2 Watt	451-551243						
R12	2.2 megohm, 20%	451-253225	Socket, Tube; Octal			006-100250		
R14	47K ohm, 20%	451-253473						
R15, 29, 58	100K ohm, 20%	451-253104	R18, 65			1K ohm		
R18, 65	1K ohm	451-252102						



- NOTES -
1. SOCKET VIEWS ARE BOTTOM VIEWS.
 2. ALL VOLTAGES ARE MEASURED BETWEEN TUBE SOCKET TERMINALS AND CHASSIS WITH ZERO SIGNAL INPUT.
 3. LINE VOLTAGE AT V, 60 CYCLES AC.
 4. ALL VOLTAGES ARE DC UNLESS OTHERWISE SPECIFIED.
 5. DC VOLTAGES SHOWN WERE MEASURED WITH A VACUUM TUBE VOLTMETER.
 6. "NC"=NO CONNECTION (VOLTAGE SHOWN FOR THIS TERMINAL ONLY WHEN TERMINAL IS USED AS A TIE LUG)
 7. "NR"=NOT READABLE (READING GENERALLY MEANINGLESS)
 8. □ SPACE PROVIDED FOR SERVICE METER READINGS.

CONTROL	SETTING
SENSITIVITY	FULL CLOCKWISE
AVC	ON
CW/AM	AM
NOISE LIMITER	OFF
STANDBY/RECEIVE	RECEIVE

* AM/CW SWITCH IN CW POSITION.

FRONT APRON
BOTTOM VIEW OF CHASSIS

079-50697-2

Figure 9. Model S-108 Voltage Chart.

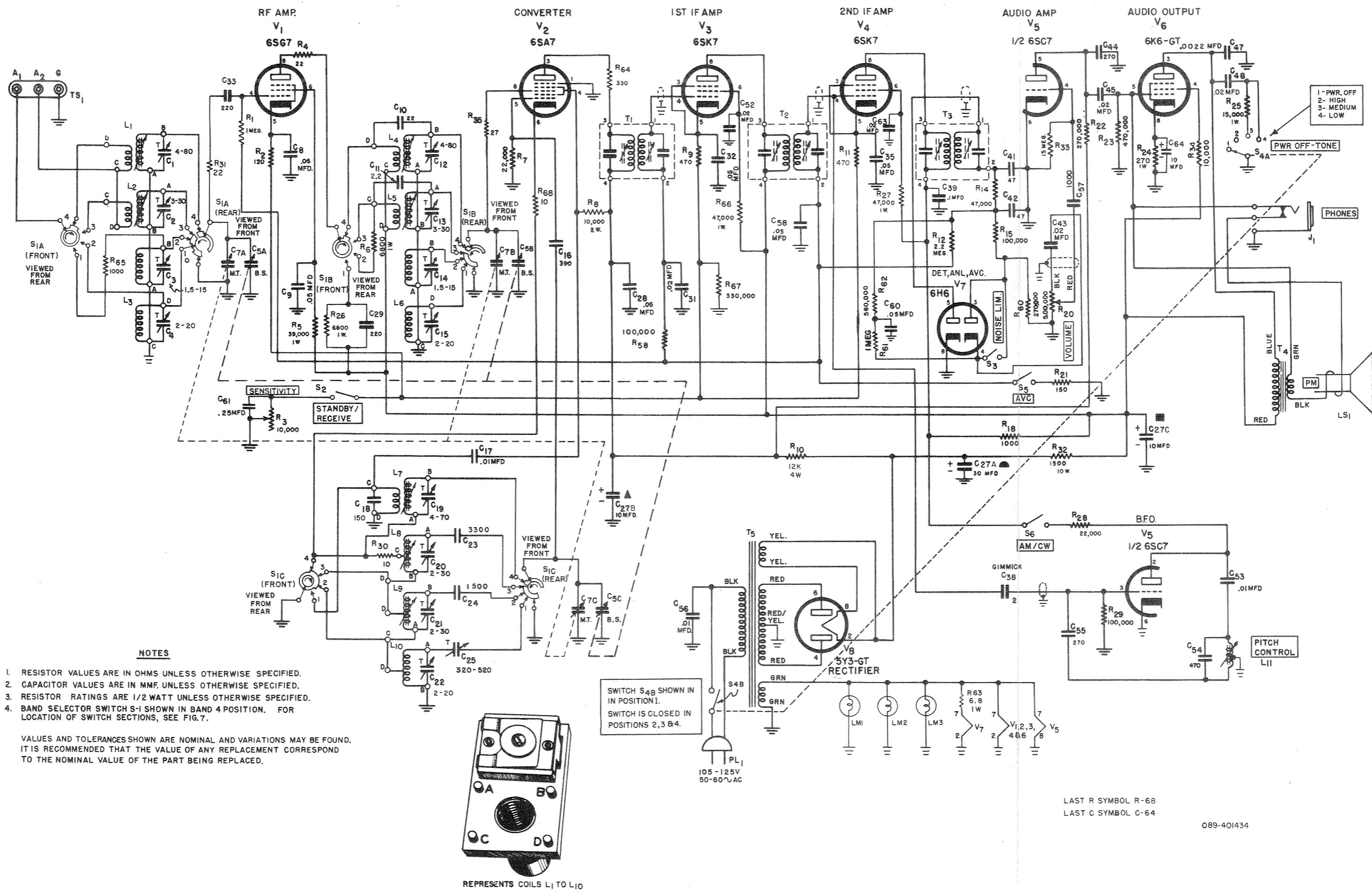

NOTES

1. RESISTOR VALUES ARE IN OHMS UNLESS OTHERWISE SPECIFIED.
2. CAPACITOR VALUES ARE IN MMF. UNLESS OTHERWISE SPECIFIED.
3. RESISTOR RATINGS ARE 1/2 WATT UNLESS OTHERWISE SPECIFIED.
4. BAND SELECTOR SWITCH S-1 SHOWN IN BAND 4 POSITION. FOR LOCATION OF SWITCH SECTIONS, SEE FIG. 7.

VALUES AND TOLERANCES SHOWN ARE NOMINAL AND VARIATIONS MAY BE FOUND. IT IS RECOMMENDED THAT THE VALUE OF ANY REPLACEMENT CORRESPOND TO THE NOMINAL VALUE OF THE PART BEING REPLACED.

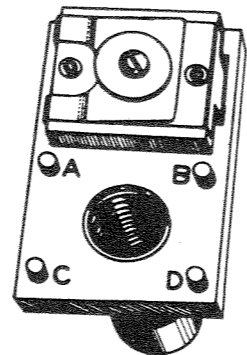

REPRESENTS COILS L₁ TO L₁₀

SWITCH S_{4B} SHOWN IN POSITION 1. SWITCH IS CLOSED IN POSITIONS 2, 3 & 4.

LAST R SYMBOL R-68
LAST C SYMBOL C-64

089-401434

Figure 10. Model S-108 Schematic Diagram.

NOTES

Warranty

"The Hallicrafter's Company warrants each new radio product manufactured by it to be free from defective material and workmanship and agrees to remedy any such defect or to furnish a new part in exchange for any part of any unit of its manufacture which under normal installation, use and service discloses such defect, provided the unit is delivered by the owner to our authorized radio dealer, wholesaler, from whom purchased, or, authorized service center, intact, for examination, with all transportation charges prepaid within ninety days from the date of sale to original purchaser and provided that such examination discloses in our judgment that it is thus defective.

This warranty does not extend to any of our radio products which have been subjected to misuse, neglect, accident, incorrect wiring not our own, improper installation, or to use in violation of instructions furnished by us, nor extend to units which have been repaired or altered outside of our factory or authorized service center, nor to cases where the serial number thereof has been removed, defaced or changed, nor to accessories used therewith not of our own manufacture.

Any part of a unit approved for remedy or exchange hereunder will be remedied or exchanged by the authorized radio dealer or wholesaler without charge to the owner.

This warranty is in lieu of all other warranties expressed or implied and no representative or person is authorized to assume for us any other liability in connection with the sale of our radio products."

Form No. 94X622

the Hallicrafters co.