

PRICE, \$2.00

# HEATHKIT® ASSEMBLY MANUAL

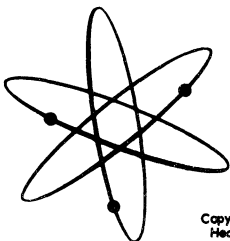

Copyright © 1967  
Heath Company  
All rights reserved

## TRANSMITTER MODEL DX-60B

595-944-03

Dear Customer:

You have just purchased one of the best performing electronic products in the world — your Heathkit.

Here's how we aim to keep it that way:

### Your Heathkit Warranty

During your first 90 days of ownership, any parts which we find are defective, either in materials or workmanship, will be replaced or repaired free of charge. And we'll pay shipping charges to get those parts to you — anywhere in the world.

If we determine a defective part has caused your Heathkit to need other repair, through no fault of yours, we will service it free — at the factory, at any retail Heathkit Electronic Center, or through any of our authorized overseas distributors.

This protection is exclusively yours as the original purchaser. Naturally, it doesn't cover damage by use of acid-core solder, incorrect assembly, misuse, fire, flood or acts of God. But, it does insure the performance of your Heathkit anywhere in the world — for most any other reason.

### After-Warranty Service

What happens after warranty? We won't let you down. If your Heathkit needs repairs or you need a part, just write or call the factory, your nearest retail Heathkit Electronic Center, or any Heath authorized overseas distributor. We maintain an inventory of replacement parts for each Heathkit model at most locations — even for models that no longer appear in our current product line-up. Repair service and technical consultation is available through all locations.

We hope you'll never need our repair or replacement services, but it's nice to know you're protected anyway — and that cheerful help is nearby.

Sincerely,

HEATH COMPANY  
Benton Harbor, Michigan 49022

Assembly  
and  
Operation  
of the



**TRANSMITTER**

MODEL DX-60B



HEATH COMPANY  
BENTON HARBOR,  
MICHIGAN 49022

**TABLE OF CONTENTS**

Specifications . . . . .	2
Introduction . . . . .	3
Circuit Description . . . . .	3
Construction Notes . . . . .	5
Parts List . . . . .	6
Proper Soldering Techniques . . . . .	8
Step-By-Step Procedure . . . . .	10
Step-By-Step Assembly -	
Chassis Parts Mounting . . . . .	10
Wiring Chassis Bottom . . . . .	14
Transformer Wiring . . . . .	18
Component Wiring . . . . .	18
General Chassis Assembly . . . . .	22
Top Of Chassis Assembly And Wiring . . . . .	24
Low-Pass Filter Assembly . . . . .	28
Final Wiring . . . . .	30
Initial Test And Adjustment . . . . .	34
Final Assembly . . . . .	36
Operation . . . . .	38
In Case Of Difficulty . . . . .	40
Factory Repair Service . . . . .	41
Replacement Parts Price List . . . . .	42
Schematic . . . (fold-out from page) . . . . .	43

## SPECIFICATIONS

Power Input. . . . .	90 watts CW and controlled-carrier phone.
Output Impedance. . . . .	50-75 $\Omega$ .
Output Coupling. . . . .	Pi network (coaxial).
Band Coverage. . . . .	80, 40, 20, 15, and 10 meters.
Front Panel Controls. . . . .	Meter switch Function switch Drive Level Crystal-VFO switch (4 crystal positions) Drive Tune Band switch Final Tuning Final Loading
Tube Complement. . . . .	1 - 12AX7, Speech amplifier 1 - 6DE7, Controlled-carrier modulator 1 - 6CL6, Crystal oscillator 1 - 6CL6, Driver 1 - 6146, Final amplifier
Power Requirements. . . . .	105-125 or 210-250 volts AC, 50/60 cps, 225 watts.
Cabinet Size. . . . .	13-3/4" wide x 11-1/2" deep x 6-1/2" high.
Net Weight. . . . .	23 lbs.

The Heath Company reserves the right to discontinue instruments and to change specifications at any time without incurring any obliga-

tion to incorporate new features in instruments previously sold.



## INTRODUCTION

The Heathkit Model DX-60B Transmitter is designed as a versatile and economical transmitter for General and Novice Class amateur operation. It features up to 90 watts input, controlled carrier phone operation, four switched crystal positions, and provisions for the use of a variable frequency oscillator (VFO). Panel controls allow for Crystal or VFO, and Phone or CW operation.

Front panel controls consist of Band switch, Drive Tune control, Drive Level control, Crystal-VFO switch, Final Tuning control, Final Loading control, and Function switch. The meter face is calibrated to indicate both grid drive and plate current. A slide switch directly below the meter, enables the operator to rapidly

check grid drive or plate current. The Mike and Key jacks are on the front panel for easy accessibility.

An accessory power socket is provided on the rear chassis apron. At this socket, 300 volts at 50 ma DC and 6.3 volts AC are available for VFO operation. Switched 117 volt AC power is also available for antenna relay operation.

Refer to the "Kit Builders Guide" for complete information on unpacking, parts identification, tools, wiring, soldering, and step-by-step assembly procedures.

## CIRCUIT DESCRIPTION

The DX-60B Transmitter has seven basic circuits. These are shown on the Block Diagram. While reading the Circuit Description, we suggest that you follow the circuit on the Block and Schematic Diagrams (fold-out from Page 43).

### OSCILLATORS

Oscillator tube, stage V1, operates as a modified Pierce crystal oscillator. This oscillator can be operated at the fundamental frequency of either an 80 or 40 meter crystal. When the Transmitter is used with a VFO, V1 operates as a buffer stage. The plate circuit of V1 is untuned for 80 meter operation, and is slug tuned by coil L1 for operation on 40 through 10 meters. The output of V1 is capacitively coupled to driver stage V2 through capacitor C4.

### DRIVER

V2 is used as a driver stage. The plate circuit of V2 is tuned to the desired operating frequency by coil L2 and variable capacitor C9. This stage operates straight-through on 80 and 40 meters, as a doubler on 20, as a tripler on 15, and as a quadrupler on 10 meters. The amount of output (drive) is adjusted by varying the screen voltage of V2 with Drive Level control R7. Drive is capacitively coupled to the grid of final amplifier V3 through capacitor C11.

### FINAL AMPLIFIER

Final amplifier tube V3 operates on all bands as a shunt-fed, straight-through, neutralized amplifier. The tank circuit consists of capacitors C20A, C20B, C22, C23, and C24 and coil L3. Variable loading capacitor (C22, C23, and C24) has three 450  $\mu\mu\text{f}$  sections to eliminate the necessity of switching fixed capacity into or out of the circuit when changing bands.

The amplifier output is applied to a low-pass filter consisting of coils L4 through L8, and capacitors C25 through C28. This low-pass filter has a cutoff point of approximately 34 mc and suppresses RF energy above this frequency. The output should be fed into an unbalanced 50 to 75  $\Omega$  line.

The cathode and grid currents of the final amplifier are measured with a 0-1 ma meter. The appropriate shunt, R11, and R12 for grid current, or R13 for cathode current, is selected by the Meter switch, located on the front panel.

### SPEECH AMPLIFIER

Speech amplifier V5 operates as a conventional resistance coupled audio amplifier. The plate of V5 is coupled to one-half of modulator tube V4 through capacitor C34.

## MODULATION

Modulator tube V4 contains two dissimilar triodes, one having a power rating of 1.5 watts and the other 7 watts. The lower power section is used as a direct coupled driver to excite the higher rated section, which is actually the modulator. The cathode of the modulator section is coupled to the screen grid of V3, the final amplifier tube, through R27 and C36.

V4 is biased so that with no audio signal the conduction of the tube is limited. This allows the screen voltage of V3 to remain at a low value, thus limiting the plate current of V3 to a low resting state.

With modulation applied, conduction in the modulator section of V4 increases, raising the screen voltage of V3. This results in an increase in final plate current with modulation producing a controlled-carrier effect.

## POWER SUPPLY

The power supply section uses four silicon diodes in a voltage-doubler circuit. Filtering is accomplished by capacitors C39, C40, C41, and C42, and resistors R34 and R35.

Bias voltage for grid block keying is developed by a silicon diode in a half-wave rectifier circuit, 6.3 volts AC at 2 amperes for VFO filaments or other accessory equipment is available at the accessory power socket.

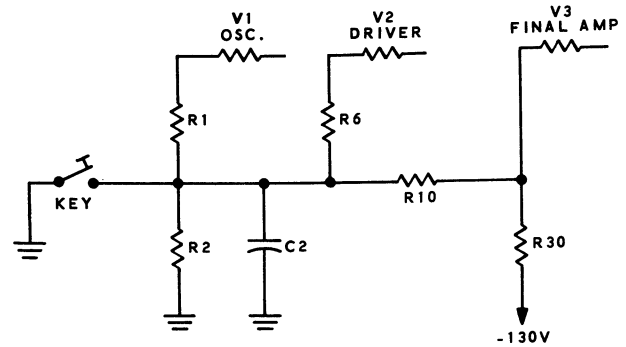

GRID BLOCK KEYING

Figure 1

## GRID BLOCK KEYING

In order to explain grid block keying, it is necessary to consider key-up and key-down conditions. See Figure 1.

### KEY-UP

With a key-up condition, a negative voltage is placed on the grids of tubes V1, V2, and V3. Since this bias voltage cuts these tubes off, there can be no transmitter output.

### KEY-DOWN

Under this condition, R2 is shorted, removing the bias voltage from V1 and V2. At the same time the bias to V3 is reduced to operating level through resistor R10. The values of C2 and R2 were chosen to provide the most desirable waveform for CW operation.

## CONSTRUCTION NOTES

This manual is supplied to assist you in every way to complete your kit with the least possible chance for error. The arrangement shown is the result of extensive experimentation and trial. If followed carefully, the result will be highly stable and dependable performance. We suggest that you retain the manual in your files for future reference, both in the use of the equipment and for its maintenance.

**UNPACK THE KIT CAREFULLY AND CHECK EACH PART AGAINST THE PARTS LIST.** In so doing, you will become acquainted with the parts. Refer to the information on the inside covers of the manual to help you identify the components. If some shortage or parts damage is found in checking the Parts List, please read the Replacements section and supply the information called for therein.

Resistors generally have a tolerance rating of 10% unless otherwise stated in the Parts List. Tolerances on capacitors are generally even greater. Limits of +100% and -20% are common for electrolytic capacitors.

We suggest that you do the following before work is started:

1. Lay out all parts so that they are readily available.
2. Provide yourself with good quality tools. Basic tool requirements consist of a screwdriver with a 1/4" blade; a small screwdriver with a 1/8" blade; long-nose pliers; wire cutters, preferably separate diagonal cutters; a penknife or a tool for stripping insulation from wires; a soldering iron (or gun) and rosin core solder. A set of nut drivers, while not necessary, will aid extensively in construction of the kit.

Most kit builders find it helpful to separate the various parts into convenient categories. Muffin tins or molded egg cartons make convenient trays for small parts. Resistors and capacitors may be placed with their lead ends inserted in the edge of a piece of corrugated cardboard until they are needed. Values can be written on the cardboard next to each component. The illustration shows one method that may be used.

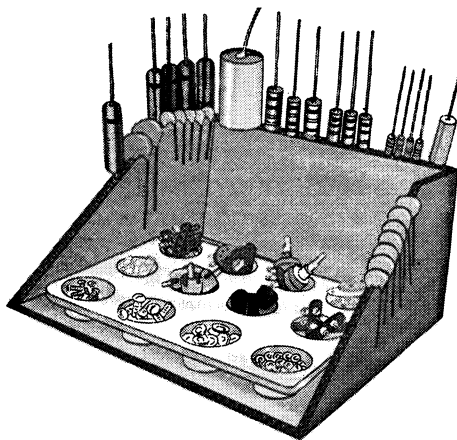

## PARTS LIST

The numbers in parentheses in the Parts List are keyed to the numbers on the Parts Pictorial (fold-out from Page 9) to aid in parts identification.

To order replacement parts, refer to the Replacement Parts Price List and use the Parts Order Form furnished with this kit.

PART No.	PARTS Per Kit	DESCRIPTION	PART No.	PARTS Per Kit	DESCRIPTION
----------	---------------	-------------	----------	---------------	-------------

### RESISTORS

#### 1/2 Watt

(1) 1-130	1	8.2 Ω (gray-red-gold)
1-41	1	10 Ω (brown-black-black)
1-45	1	220 Ω (red-red-brown)
1-79	2	820 Ω (gray-red-brown)
1-90	1	2000 Ω (red-black-red)
1-14	1	3300 Ω (orange-orange-red)
1-16	1	4700 Ω (yellow-violet-red)
1-69	1	18 KΩ (brown-gray-orange)
1-22	1	22 KΩ (red-red-orange)
1-24	2	33 KΩ (orange-orange-orange)
1-25	1	47 KΩ (yellow-violet-orange)
1-33	4	470 KΩ (yellow-violet-yellow)
1-35	2	1 megohm (brown-black-green)
1-37	1	2.2 megohm (red-red-green)
1-70	1	22 megohm (red-red-blue)

#### 1 Watt

(2) 1-2-1	1	1000 Ω (brown-black-red)
1-24-1	1	4700 Ω (yellow-violet-red)

#### 2 Watt

(3) 1-30-2	1	270 Ω (red-violet-brown)
1-15-2	1	1000 Ω (brown-black-red)
1-17-2	1	6800 Ω (blue-gray-red)
1-3-2	1	10 KΩ (brown-black-orange)
1-4-2	1	15 KΩ (brown-green-orange)
1-18-2	1	33 KΩ (orange-orange-orange)
1-10-2	1	47 KΩ (yellow-violet-orange)
1-24-2	2	100 KΩ (brown-black-yellow)

#### 7 Watt

(4) 3-9-7	1	100 Ω wire-wound
-----------	---	------------------

### CAPACITORS

#### Silver Mica

(5) 20-101	3	47 μmf
20-102	1	100 μmf
20-105	2	180 μmf

#### Molded Mica

(6) 20-64	1	120 μmf
20-48	1	.001 μfd, 2 KV

#### Disc

(7) 21-49	1	68 μmf, 4 KV
(8) 21-9	3	100 μmf
21-14	3	.001 μfd
21-71	1	.001 μfd 1.4 KV
21-57	14	.005 μfd
21-72	2	.005 μfd, 1.4 KV

#### Mylar\*

(9) 27-115	2	.005 μfd
------------	---	----------

#### Tubular

(10) 23-28	1	.1 μfd
------------	---	--------

#### Electrolytic

(11) 25-16	1	20 μfd, 350 V
25-36	2	40 μfd, 450 V
(12) 25-80	1	20-20 μfd, 150 V
(13) 25-37	1	40-40 μfd, 450 V

#### Variable

(14) 26-64	1	1-section
26-102	1	2-section
26-101	1	3-section

### CONTROLS-SWITCHES

(15) 11-20	1	25 KΩ control
10-58	1	100 KΩ twist-tab control
(16) 60-15	1	DPDT slide switch
(17) 63-290	1	1-wafer rotary switch
63-246	1	Ceramic rotary switch
(18) 63-244	1	2-wafer rotary switch

\*DuPont Registered Trademark





PART No.	PARTS Per Kit	DESCRIPTION	PART No.	PARTS Per Kit	DESCRIPTION
----------	---------------	-------------	----------	---------------	-------------

**TRANSFORMER-COILS-CHOKES**

54-179-24	1	Power transformer
40-644	1	Final amplifier coil
141-14	1	Coil and choke package consisting of:
(19)40-79	1	40 meter oscillator coil
(20)40-337	1	Driver plate coil
(21)40-347	2	.32 $\mu$ h low-pass filter coil
40-348	2	.44 $\mu$ h low-pass filter coil
40-349	1	.5 $\mu$ h low-pass filter coil
(22)45-3	1	1 mh RF choke
(23)45-4	1	1.1 mh RF choke
(24)45-19	1	Parasitic choke
(25)45-41	1	.425 mh RF choke

**WIRE-SLEEVING**

89-1	1	Line cord
344-54	1	Yellow hookup wire
344-52	1	Red hookup wire
344-50	1	Black hookup wire
344-51	1	Brown hookup wire
344-6	1	Large red hookup wire
340-2	1	Small bare wire
340-3	1	Large bare wire
346-1	1	Sleeving
134-25	1	Wire harness

**TUBES-LAMPS-DIODES**

411-63	2	6CL6 tube
411-109	1	6DE7 tube
411-75	1	6146 tube
411-26	1	12AX7 tube
412-36	2	NE-2E neon lamp
413-11	1	Clear lens
413-10	1	Red lens
(26)57-27	5	Silicon diode

**HARDWARE**

(44)250-49	8	3-48 x 1/4" screw
(45)250-34	4	4-40 x 1/2" screw
(46)250-7	6	6-32 x 3/16" round head screw
(47)250-56	47	6-32 x 1/4" screw
(48)250-116	4	6-32 x 1/4" black screw
(49)250-89	6	6-32 x 3/8" screw
(50)250-8	26	#6 sheet metal screw
(51)250-152	1	10-24 x 3/4" screw
(52)251-1	10	6-32 spade bolt
(53)252-1	8	3-48 nut
(54)252-15	4	4-40 nut
(55)252-3	55	6-32 nut
(56)252-4	4	8-32 nut
(57)252-30	1	10-24 nut
(58)252-31	1	10-24 wing nut
(59)252-7	7	Control nut
(60)252-22	4	6-32 speednut
(61)252-32	2	Push-on speednut
(62)254-7	13	#3 lockwasher
(63)254-1	78	#6 lockwasher
(64)254-2	4	#8 lockwasher
(65)254-3	2	#10 lockwasher
(66)254-5	1	Thin control lockwasher
(67)254-4	7	Control lockwasher
(68)253-9	4	#8 flat washer
(69)253-10	4	Control flat washer
(70)253-19	2	#10 flat washer
(71)259-6	5	#6 small solder lug
(72)259-1	2	#6 solder lug
(73)259-10	1	Control solder lug
(74)455-9	2	3/8" bushing
(75)456-7	2	1/4" shaft coupler

**TERMINAL STRIPS-SOCKETS-PHONE JACK**

(27)431-14	1	2-lug terminal strip (one lug ground)
(28)431-1	1	2-lug upright terminal strip
(29)431-10	3	3-lug terminal strip
(30)431-12	2	4-lug terminal strip
(31)431-40	1	4-lug terminal strip
(32)431-55	1	6-lug terminal strip
(33)431-45	1	6-lug terminal strip
(34)431-41	1	2-lug high voltage terminal strip
(35)431-43	1	3-lug high voltage terminal strip
431-42	2	5-lug high voltage terminal strip
(36)434-36	2	9-pin ceramic tube socket
434-43	2	9-pin molded tube socket
(37)434-39	2	Octal tube socket
(38)434-38	3	Crystal socket
(39)434-74	1	Crystal socket
(40)434-42	2	Phono socket
(41)436-4	1	Phone jack
(42)432-3	1	Microphone connector
(43)438-4	2	Phono plug



PART No.	PARTS Per Kit	DESCRIPTION
----------	---------------	-------------

**METAL PARTS**

90-358	1	Cabinet
200-425-1	1	Chassis
203-485	1	Front panel
205-259	1	Top plate
205-260	1	Bottom plate
(76) 206-271	1	Front shield
206-272	1	Rear shield
(77) 206-136	1	Oscillator shield
206-137	1	Driver shield
(78) 206-273	1	Center shield
206-274	1	Low-pass filter chassis

**MISCELLANEOUS**

453-66	1	5" shaft
453-102	1	7-7/8" shaft
462-122	5	Skirt knob
100-687	2	Knob with pointer assembly

PART No.	PARTS Per Kit	DESCRIPTION
----------	---------------	-------------

**Miscellaneous (cont'd.)**

(79) 73-4	4	5/16" grommet
(80) 73-1	1	3/8" grommet
(81) 261-9	4	Rubber foot
(82) 260-39	1	Anode clip (Appearance may vary)
206-3	1	2" tube shield
206-54	3	2-3/8" tube shield
(83) 65-9	1	Circuit breaker
(84) 75-24	1	Line cord strain relief
(85) 481-1	1	Capacitor mounting wafer
407-76	1	Meter
391-34	1	Blue and white label
	1	Manual (See front cover for part number.)
597-260	1	Parts Order Form
		Solder

**PROPER SOLDERING TECHNIQUES**

Only a small percentage of customers find it necessary to return equipment for factory service. By far the largest portion of malfunctions in this equipment are due to poor or improper soldering.

If terminals are bright and clean and free of wax, frayed insulation and other foreign substances, no difficulty will be experienced in soldering. Correctly soldered connections are essential if the performance engineered into a kit is to be fully realized. If you are a beginner with no experience in soldering, a half hour's practice with some odd lengths of wire may be a worthwhile investment.

For most wiring, a 25 to 100 watt iron or its equivalent in a soldering gun is very satisfactory. A lower wattage iron than this may not heat the connection enough to flow the solder smoothly. Keep the iron tip clean by wiping it from time to time with a cloth.

**CHASSIS WIRING AND SOLDERING**

1. Unless otherwise indicated, all wire used is the type with colored insulation (hookup wire). In preparing a length of hookup wire, 1/4" of insulation should be removed from each end unless directed otherwise in the assembly step.
2. To avoid breaking internal connections when stripping insulation from the leads of transformers or similar components, care should be taken not to pull directly on the lead. Instead, hold the lead with pliers while it is being stripped.
3. Leads on resistors, capacitors, and similar components are generally much longer than need be to make the required connections. In these cases, the leads should be cut to proper length before the part is installed. In general, the leads should be just long enough to reach their terminating points.

4. Wherever there is a possibility of bare leads shorting to other parts or to the chassis, the leads should be covered with insulating sleeving. Where the use of sleeving is specifically intended, the phrase "use sleeving" is included in the associated assembly step. In any case where there is the possibility of an unintentional short circuit, sleeving should be used. Extra sleeving is provided for this purpose.

5. Crimp or bend the lead (or leads) around the terminal to form a good joint without relying on solder for physical strength. If the lead is too large to allow bending or if the step states that it is not to be crimped, position it so that a good solder connection can still be made.

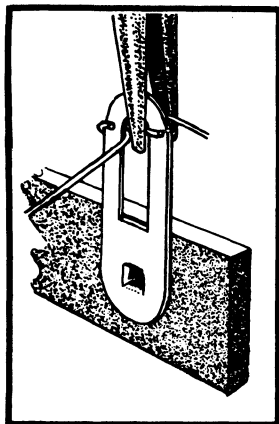

6. Position the work, if possible, so that gravity will help to keep the solder where you want it.

7. Place a flat side of the soldering iron tip against the joint to be soldered until it is heated sufficiently to melt the solder.

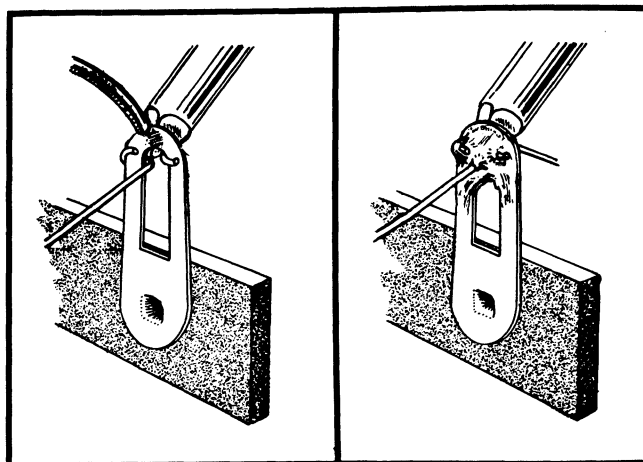
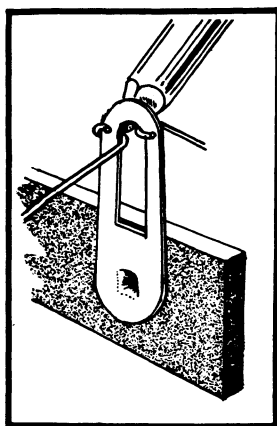

8. Then place the solder against the connection and it will immediately flow over the joint; use only enough solder to thoroughly wet the junction. It is usually not necessary to fill the entire hole in the terminal with solder.
9. Remove the solder and then the iron from the completed joint. Use care not to move the leads until the solder is solidified.

A poor or cold solder joint will usually look crystalline and have a grainy texture, or the solder will stand up in a blob and will not have adhered to the joint. Such joints should be reheated until the solder flows smoothly. In some cases, it may be necessary to add a little more solder to achieve a smooth, bright appearance.

ROSIN CORE SOLDER HAS BEEN SUPPLIED WITH THIS KIT. THIS TYPE OF SOLDER MUST BE USED FOR ALL SOLDERING IN THIS KIT. ALL GUARANTEES ARE VOIDED AND WE WILL NOT REPAIR OR SERVICE EQUIPMENT IN WHICH ACID CORE SOLDER OR PASTE FLUXES HAVE BEEN USED. IF ADDITIONAL SOLDER IS NEEDED, BE SURE TO PURCHASE ROSIN CORE (60:40 or 50:50 TIN-LEAD CONTENT) RADIO TYPE SOLDER.

## STEP-BY-STEP PROCEDURE

The following instructions are presented in a logical step-by-step sequence to enable you to complete your kit with the least possible confusion. Be sure to read each step all the way through before beginning the specified operation. Also read several steps ahead of the actual step being performed. This will familiarize you with the relationship of the subsequent operations. When the step is completed, check it off in the space provided. This is particularly important as it may prevent errors or omissions, especially if your work is interrupted. Some kit builders have also found it helpful to mark each wire and part in colored pencil on the Pictorial as it is added.

### ILLUSTRATIONS

The fold-out diagrams in this manual may be removed and attached to the wall above your working area; but because they are an integral part of the instructions, they should be returned to the manual after the kit is completed.

In general, the illustrations in this manual correspond to the actual configuration of the kit; however, in some instances the illustrations may be slightly distorted to facilitate clearly showing all of the parts.

### SOLDERING

The abbreviation "NS" indicates that a connection should not be soldered yet as other wires will be added. When the last wire is installed, the terminal should be soldered and the abbreviation "S" is used to indicate this. Note that a number will appear after each solder instruction. This number indicates the number of leads that are supposed to be connected to the terminal in point before it is soldered. For example, if the instruction reads, "Connect a wire to lug 1 (S-2)," it will be understood that there will be two wires connected to the terminal at the time it is soldered. (In cases where a wire passes through a terminal or lug and then connects to another point, it will count as two wires, one entering and one leaving the terminal.)

## STEP-BY-STEP ASSEMBLY

### CHASSIS PARTS MOUNTING

**NOTE:** Lockwashers will be used with all screws and nuts when mounting parts, unless directed otherwise. The following steps will call out only the size and type of the hardware to be used.

Where 6-32 hardware is specified, a 6-32 x 1/4" screw, #6 lockwashers, and a 6-32 nut should be used. When 3-48 hardware is specified, a 3-48 x 1/4" screw, #3 lockwashers, and a 3-48 nut should be used. For terminal strip mounting, use an additional lockwasher under the mounting foot. Also, a plastic nut starter is provided for your convenience. Refer to the inside front cover of this Manual for information on its use.

Refer to Pictorial 1 for the following steps.

**NOTE:** Position the blank space of each tube socket as shown by the large arrows in the Pictorial.

⚡ Referring to Detail 1A, mount a 9-pin ceramic tube socket at V1 and V2. Use 3-48 hardware with a #6 small solder lug at EE and ED. Bend the solder lug up.

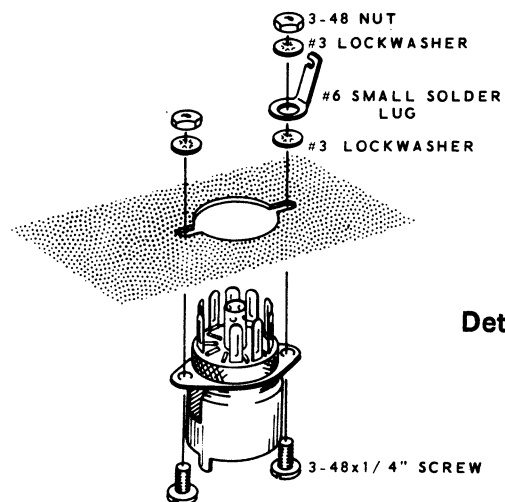

Detail 1A

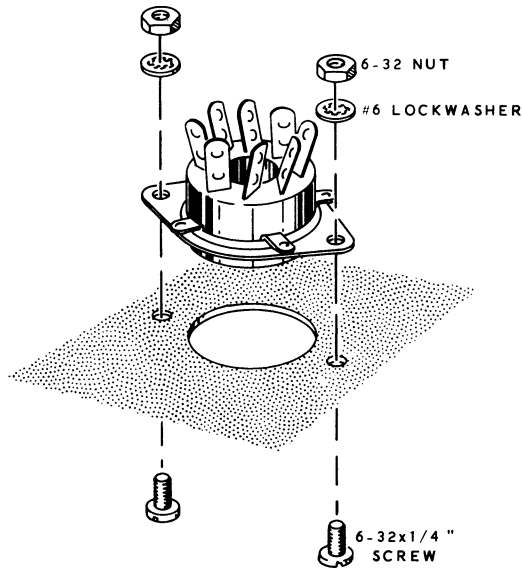

Detail 1B

(X) Mount a 9-pin molded tube socket at V4 and V5. Use 3-48 hardware with a #6 small solder lug at EA, EB, and EC. Bend the solder lugs up.

(X) Referring to Detail 1B, mount an octal tube socket at V3 and BE. Use 6-32 hardware.

NOTE: Several similar types of terminal strips are used in this kit (two 4-lug types, three 2-lug types, etc.). Be sure to install the correct terminal strip in each step, as shown on the Parts Pictorial and in Pictorial 1.

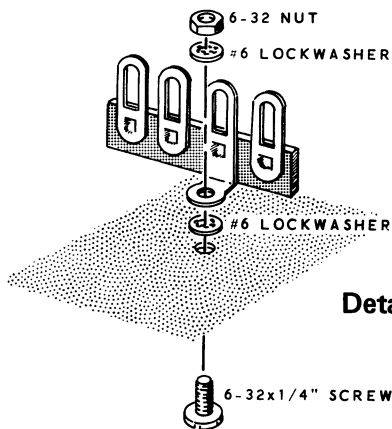

Detail 1C

(X) Mount a 4-lug terminal strip (#431-40) at A. Use 6-32 hardware. There are two types of 4-lug terminal strips. Use the one shown in Detail 1C.

(X) Mount 4-lug terminal strips (#431-12) at C and M. Use 6-32 hardware.

(X) Mount a 3-lug terminal strip (#431-10) at L. Use 6-32 hardware.

(X) Mount a 6-lug terminal strip (#431-45) at N. Use 6-32 hardware.

(X) Mount 5-lug high voltage terminal strips (#431-42) at E and F. Use 6-32 hardware.

(X) Mount a 3-lug high voltage terminal strip (#431-43) at G. Use 6-32 hardware.

(X) Referring to Detail 1D, mount the capacitor mounting wafer at K with a 3-lug terminal strip (#431-10) at J. Use a 6-32 x 3/8" screw, two #6 lockwashers, and a 6-32 nut at J. Use 6-32 hardware at the other mounting hole in the wafer.

(X) Mount a 40-40  $\mu$ fd electrolytic capacitor to the wafer at K. Twist the mounting lugs 1/8 turn. Be sure to position the capacitor lug markings as shown in the Pictorial.

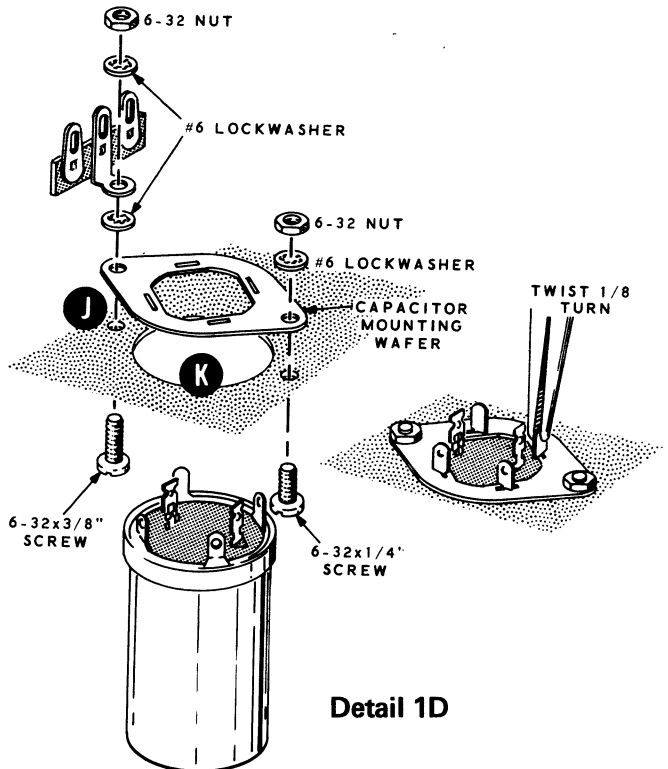

Detail 1D

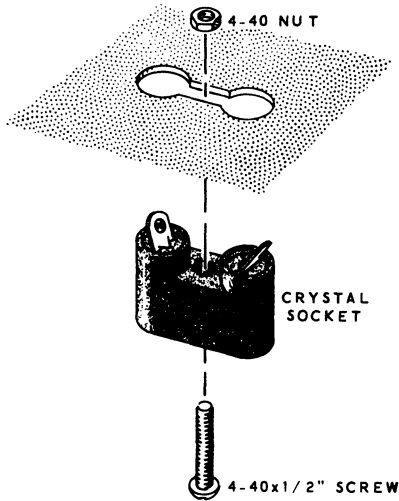

Detail 1E

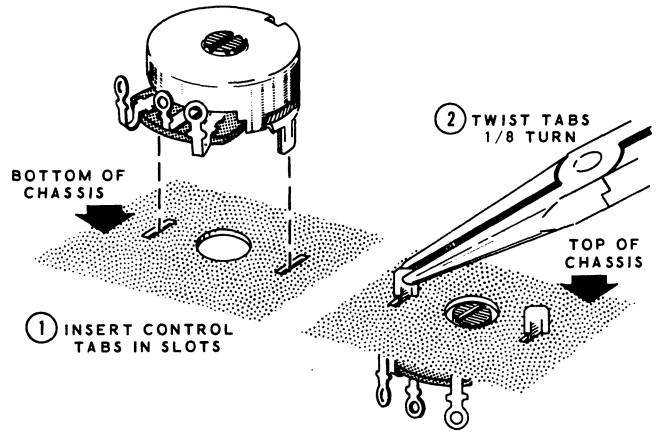

Detail 1F

(X) Referring to Detail 1E, mount a crystal socket (#434-38) at X2, X3, and X4. Use 4-40 x 1/2" screws and 4-40 nuts.

(X) Similarly, mount a crystal socket (#434-74) at X1. Use a 4-40 x 1/2" screw and 4-40 nut.

(X) Referring to Detail 1F, mount a 100 KΩ twist-tab control (#10-58) at D. Secure the control by twisting each tab 1/8 turn.

(X) Install a 5/16" grommet at B, P, and Q.

(X) Install a 3/8" grommet at R.

(X) Mount a phono socket at BF. Use 6-32 hardware. See Detail 1G.

(X) Refer to Detail 1H and install a 10-24 x 3/4" screw at BG. Use two #10 lockwashers, one on each side of the chassis rear apron, and a 10-24 nut. Now, place the two #10 flat washers over the screw and secure them with the 10-24 wing nut.

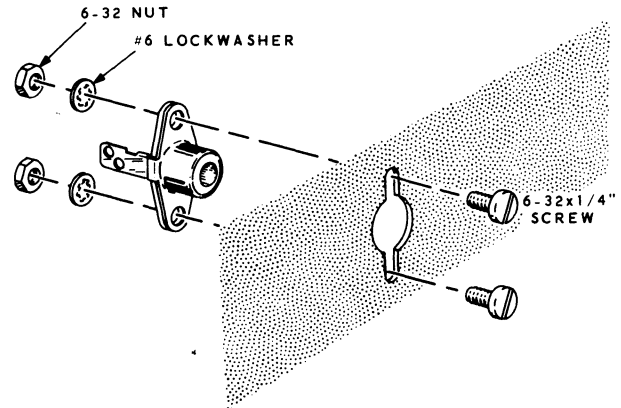

Detail 1G

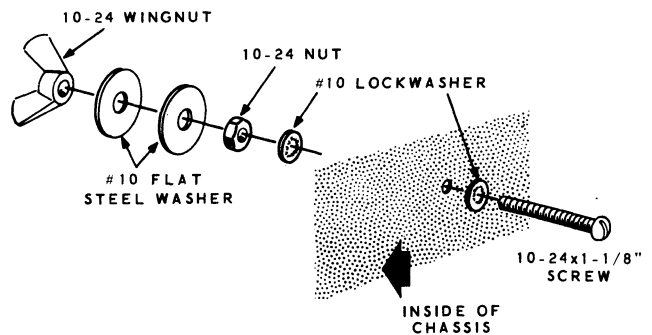

Detail 1H

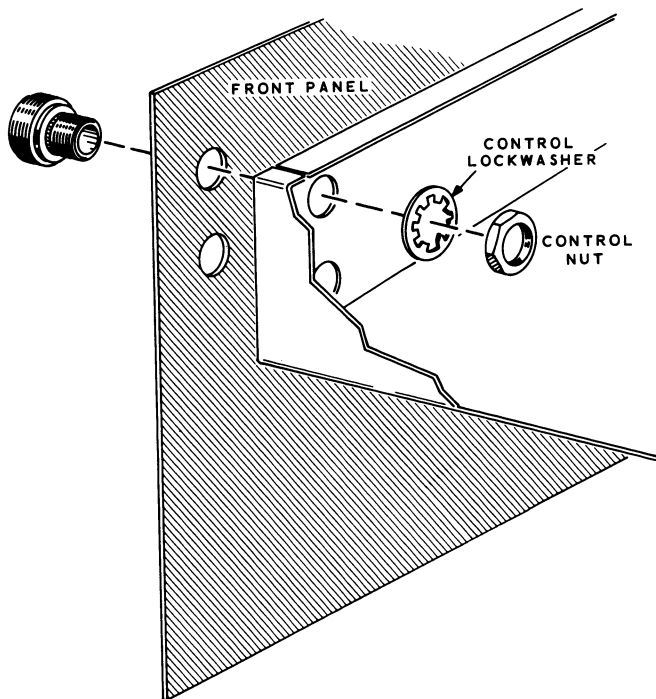

Detail 1J

NOTE: Do not use the thin control lockwasher until told to do so.

- (X) Referring to Detail 1J, install the front panel to the chassis. Use a microphone connector, control lockwasher, and control nut at AA. Discard the solder lug supplied with the connector. Also, do not tighten the control nut yet.
- (X) Fasten the center of the front panel to the chassis with a bushing at AD and AE. Use a control lockwasher and control nut on each bushing. Center the front panel and chassis holes, then tighten the control nuts at AA, AD, and AE.
- (X) Refer to Detail 1K and insert the red lens through the front of the chassis below hole AG. Push the speednut over the back of the lens with the concave side of the speednut toward the chassis. Then insert a neon lamp into the lens.

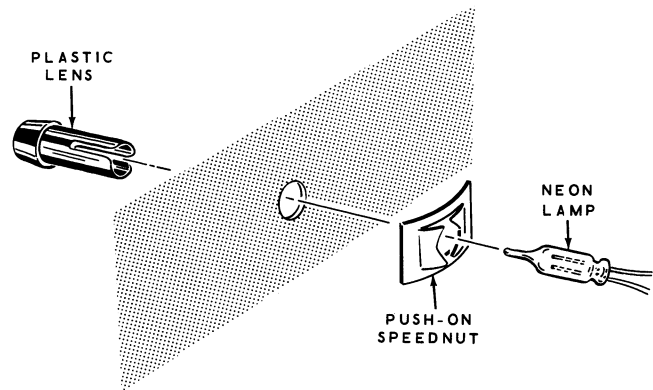

Detail 1K

- (X) Install a clear lens and neon lamp below connector AA. Use a push-on speednut.
- (X) Place four 6-32 speednuts on the sides of the chassis as shown in Pictorial 1. Be sure that the flat sides of the speednuts face outward.
- (X) Referring to Detail 1L, mount the power transformer to the chassis. Use #8 lockwashers, and 8-32 nuts.
- (X) Mount a 6-lug terminal strip (#431-55) on the rear panel at BD. Use 6-32 hardware.

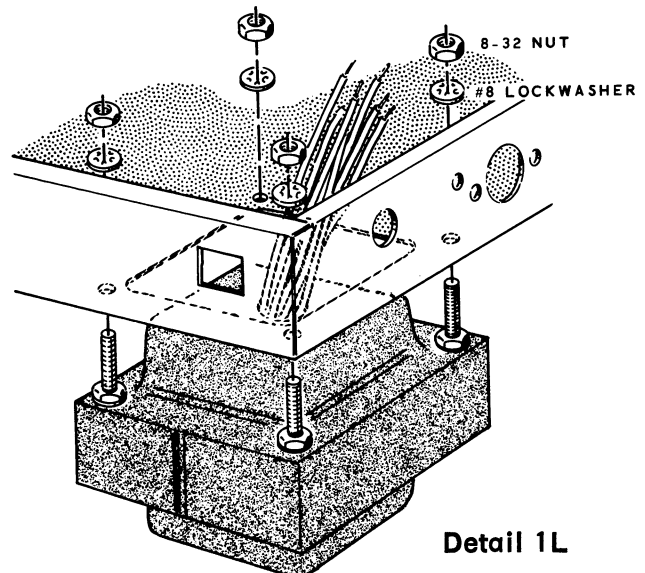

Detail 1L

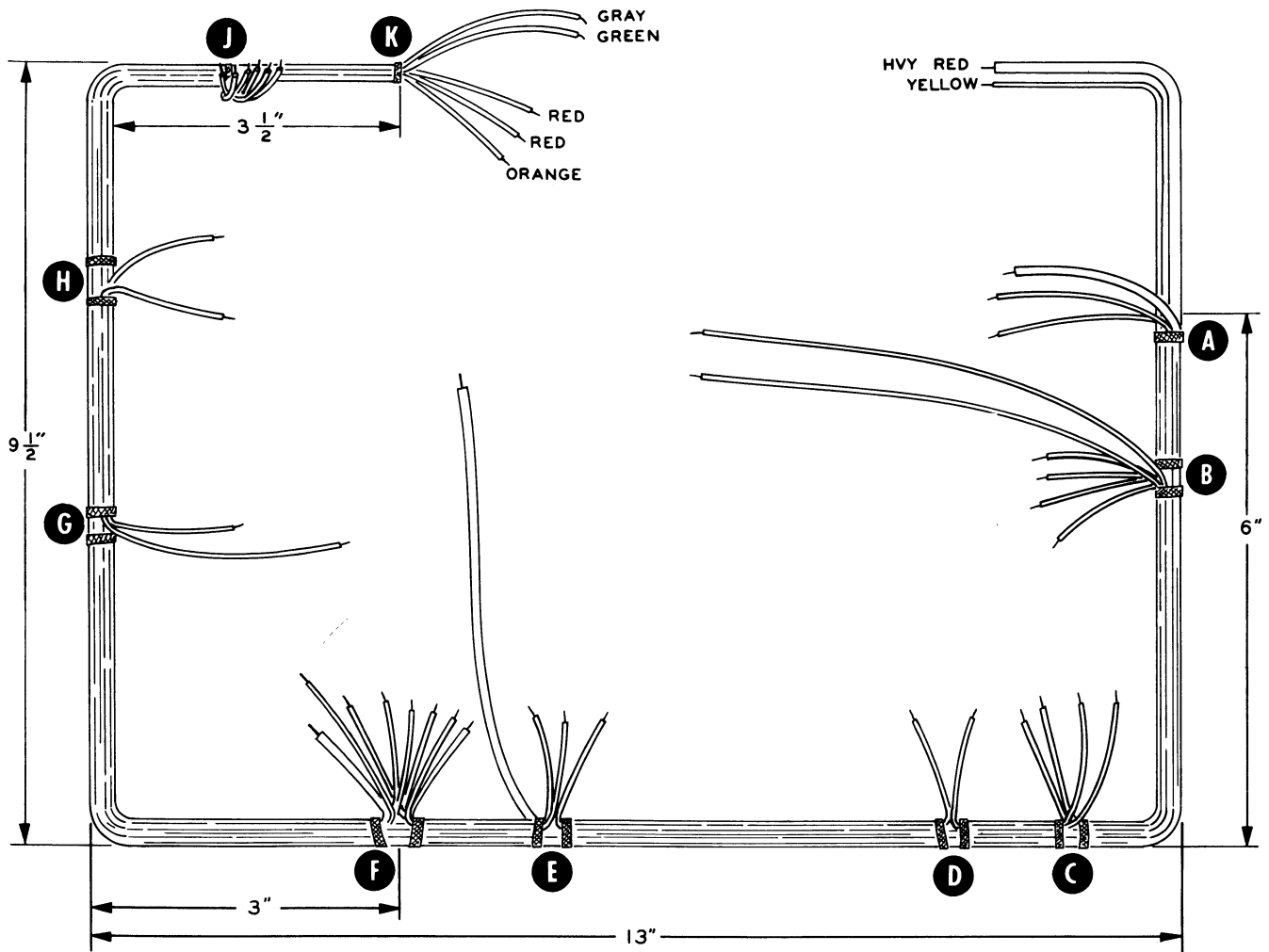

Detail 2A

**WIRING CHASSIS BOTTOM**

Refer to Pictorial 2 (fold-out from Page 17) for the following steps.

(X) Referring to Detail 2A, shape the wiring harness to the dimensions as shown.

(X) Place the harness on the chassis bottom with the end containing the long red and yellow wires near hole AG as shown in the Pictorial.



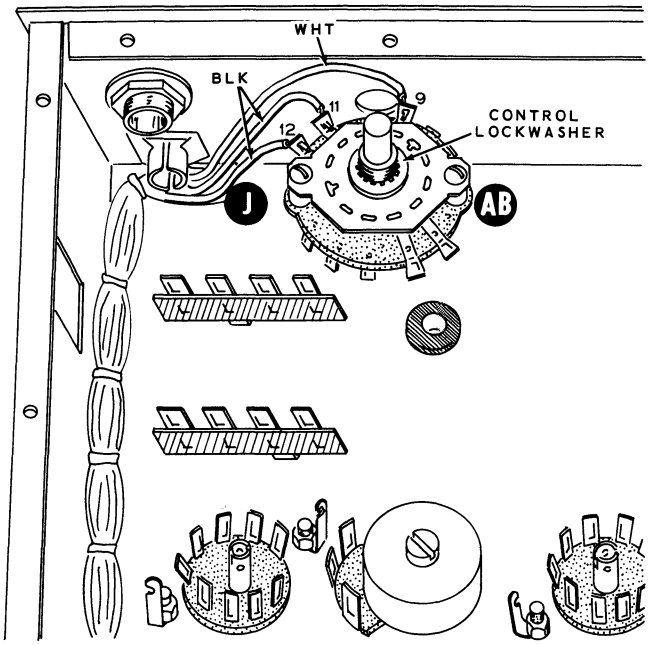

Detail 2B

- (X) Place the ceramic rotary switch (#63-246) in the approximate position as shown in Detail 2B. Note position of the switch lugs.
- (X) Connect the white harness wire coming from breakout point J to lug 9 of switch AB (S-1).
- (X) Connect either black harness wire coming from breakout point J to lug 11 (S-1) and the other black wire to lug 12 (S-1) of switch AB.
- (X) Examine these switch connections to be sure they are correct before proceeding.
- (X) Install a control lockwasher on the switch bushing. Mount the switch at AB. Use a control flat washer and control nut.

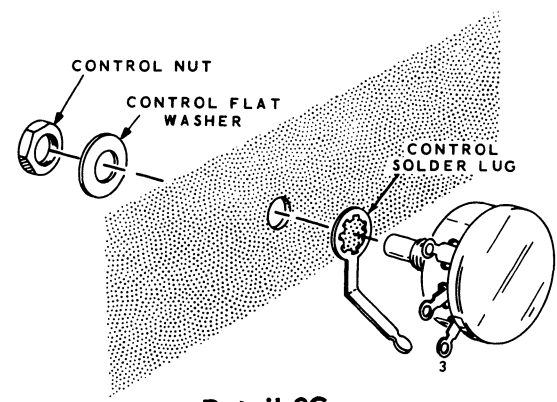

Detail 2C

(X) Referring to Detail 2C, mount the 25 KΩ control (#11-20) at AC. Use a control solder lug, control flat washer, and control nut. Position the control solder lug against lug 3 of the control as shown in Pictorial 2.

NOTE: The wires coming from the harness breakout points will be connected in the following steps.

BREAKOUT POINT K:

- (X) Either red to lug 5 of switch AB (S-1).
- (X) The other red to lug 4 of switch AB (S-1).
- (X) Orange to lug 2 of control AC (S-1).
- (X) Place the gray and green wires through grommet B to be connected later.

BREAKOUT POINT J:

- (X) Orange to lug 3 of switch AB (S-1).
- (X) Either yellow to lug 7 of switch AB (S-1).
- (X) Other yellow to lug 8 of switch AB (S-1).
- (X) Red to lug 4 of terminal strip A (NS).
- (X) Gray to lug 3 of terminal strip A (NS).



## BREAKOUT POINT H:

- ~~(X)~~ Yellow to lug 1 of terminal strip C (NS).
- ~~(X)~~ Brown to lug 5 of tube socket V5 (NS).

## BREAKOUT POINT G:

- ~~(X)~~ Yellow to lug 2 of terminal strip F (NS).
- ~~(X)~~ Red to lug 4 of terminal strip F (NS).

## BREAKOUT POINT F:

- ~~(X)~~ Red to lug 1 of terminal strip J (NS).
- ~~(X)~~ Large black to lug 3 of terminal strip J (NS).
- ~~(X)~~ Both brown to lug 3 of terminal strip J (NS).
- ~~(X)~~ Both yellow to lug 8 of socket BE (S-2).
- ~~(X)~~ Either black to lug 3 of terminal strip BD (NS).
- ~~(X)~~ Other black to lug 5 of terminal strip BD (NS).
- ~~(X)~~ Connect a length of small bare wire between lug 1 (S-1) and ground lug 9 (S-1) of socket BE.

## BREAKOUT POINT E:

- ~~(X)~~ Large red to lug 3 of terminal strip G (NS). This lead will be removed temporarily in the Neutralization Adjustment section of the Manual. Therefore, do not crimp the end of the lead around the lug.
- ~~(X)~~ Both red to lug 2 of electrolytic capacitor K (NS).
- ~~(X)~~ Solder mounting lug 3 to the capacitor mounting wafer.
- ~~(X)~~ White to lug 5 of socket BE (S-1).

## BREAKOUT POINT D:

- ~~(X)~~ Both brown to lug 5 of tube socket V1 (NS).

## BREAKOUT POINT C:

- ~~(X)~~ Both red to lug 3 of terminal strip M (NS).
- ~~(X)~~ Both yellow to lug 4 of terminal strip M (NS).

## BREAKOUT POINT B:

- ~~(X)~~ Yellow to lug 2 of terminal strip N (NS).
- ~~(X)~~ Red to lug 3 of terminal strip N (NS).
- ~~(X)~~ Green to lug 5 of terminal strip N (NS).
- ~~(X)~~ Gray to lug 6 of terminal strip N (NS).
- ~~(X)~~ Brown to lug 5 of tube socket V2 (NS). Position as shown.
- ~~(X)~~ Orange to lug 8 of tube socket V2 (NS). Position as shown.

## BREAKOUT POINT A:

- ~~(X)~~ Large black to lug 2 of tube socket V3 (NS).
- ~~(X)~~ Orange to lug 3 of tube socket V3 (NS).
- ~~(X)~~ Gray to lug 6 of tube socket V3 (NS).
- ~~(X)~~ Insert the large red wire through grommet R to be connected later.

This completes the harness wiring except for the yellow and red wires at breakout point A.

Use the large red hookup wire in the following steps.

- ~~(X)~~ Connect a 3" large red wire from lug 5 of tube socket V3 (S-1) to lug 1 of terminal strip N (NS). Position this wire as shown in Pictorial 2.

(X) Connect a 4" large red wire from lug 3 of terminal strip G (NS) to lug 1 of tube socket V4 (NS).

(X) Connect a 2" large red wire from lug 2 of terminal strip G (NS) to lug 5 of terminal strip F (NS).

NOTE: In the following steps, use small hookup wire unless large wire is specifically called for.

(X) Connect a 5" red wire from lug 1 of terminal strip G (NS) to lug 1 of electrolytic capacitor K (NS).

(X) Connect one end of a 4-1/2" yellow wire to lug 3 of terminal strip A (NS). Place the other end through grommet B to be connected later.

(X) Connect either lead of the clear neon lamp to lug 1 of terminal strip A (NS). Use a 3/4" length of sleeving.

(X) Connect the other lead to lug 2 of terminal strip A (NS).

(X) Connect a 9-1/2" yellow wire from lug 2 of terminal strip N (NS) to lug 1 of terminal strip L (NS).

(X) Connect one end of a 4-1/2" black wire to lug 3 of control AC (NS). Place the other end through grommet B to be connected later.

NOTE: When soldering a wire that passes through a terminal or lug and then connects to another point, it will count as two wires, one entering and one leaving the terminal.

(X) Strip 1/2" of insulation from one end of a 4-1/2" brown wire. Connect this end through lug 4 (S-2) to lug 5 (S-2) of tube socket V5. Connect the other end of this wire to lug 4 of tube socket V4 (S-1).

(X) Connect a length of small bare wire from lug 2 of control D (S-1) to lug 2 of tube socket V5 (NS).

(X) Connect a length of small bare wire from solder lug EA (NS), through lug 9 of tube socket V5 (S-2) to the center post of V5 (NS).

(X) Connect a length of small bare wire from lug 7 (S-1), through lug 8 (S-2) to ground lug 12 (NS) of tube socket V3.

(X) Connect a .001  $\mu$ fd disc capacitor from lug 2 of terminal strip C (NS) to lug 7 of tube socket V5 (NS). Position the capacitor away from the harness as shown.

(X) Insert one lead of a 100  $\mu$ fd disc capacitor through lug 8 (NS) to the center post (NS) of tube socket V4. Connect the other lead to lug 9 of V4 (NS).

NOTE: All resistors are 1/2 watt unless specified otherwise in the step.

(X) Connect a 33 K $\Omega$  (orange-orange-orange) 2 watt resistor between lugs 8 (S-3) and 9 (NS) of tube socket V4.

(X) Insert one lead of a 1 megohm (brown-black-green) resistor through lug 2 (S-2) to lug 6 (S-1) of tube socket V4. Use a 1/2" length of sleeving between lugs 2 and 6. Connect the other lead to lug 1 of V4 (S-2).

(X) Connect a 22 K $\Omega$  (red-red-orange) resistor from lug 1 of terminal strip C (NS) to lug 3 of terminal strip A (S-3).

(X) Connect a 470 K $\Omega$  (yellow-violet-yellow) resistor from lug 1 of terminal strip C (S-3) to lug 1 of terminal strip A (S-2).

(X) Connect a 2.2 megohm (red-red-green) resistor through solder lug EA (S-3) to lug 1 of control D (S-1). Connect the other lead to lug 7 of tube socket V5 (S-2).

## TRANSFORMER WIRING

Refer to Pictorial 3 for the following steps.

- ( ) Measure the leads from where they come out of the power transformer and cut them to the following lengths:

<u>COLOR</u>	<u>LENGTH</u>
Brown	3"
Brown	3"
Red	2-3/4"
Red	4"
Green-yellow	2-1/2"
Yellow	4"
Black-green	2-1/2"
Black-yellow	4"
Black-red	4"
Black	2-1/2"

- ( ) Strip 1/4" of insulation from the end of each wire except the yellow one, and apply a small amount of solder to the tip of each bared lead.

Connect the power transformer leads as follows:

<u>COLOR</u>	<u>CONNECT TO</u>
--------------	-------------------

- |  |   |
|--|---|
| <del>(X)</del> Either brown  | lug 1 of terminal strip F (NS).         |
| <del>(X)</del> Brown   | lug 2 of terminal strip F (NS).         |
| <del>(X)</del> Short red   | lug 1 of terminal strip J (S-2).        |
| <del>(X)</del> Green-yellow  | lug 2 of terminal strip J (S-1).        |
| <del>(X)</del> Long red  | lug 1 of electrolytic capacitor K (NS). |
| <del>(X)</del> Remove 3/4" of insulation from the end of the yellow lead. Pass the bare end through lug 3 of terminal strip J (S-5) to lug 2 of socket BE (S-1). |   |

### Alternate Line Voltage Wiring

Two sets of line voltage wiring instructions are given below, one for 120 VAC line voltage and the other for 240 VAC line voltage. In the U.S.A., 120 VAC is most often used, while in foreign countries 240 VAC is more common. USE ONLY THE INSTRUCTIONS THAT AGREE WITH THE LINE VOLTAGE IN YOUR AREA.

### 120 VAC Wiring

- ~~(X)~~ Twist together loosely the black and black-green power transformer leads. Connect both to lug 2 of terminal strip BD (NS).
- ~~(X)~~ Twist together loosely the black-red and black-yellow power transformer leads. Connect both to lug 6 of socket BE (NS).

Now proceed to Component Wiring.

### 240 VAC Wiring.

Refer to Detail 3A for the following steps.

- ~~( )~~ Cut the black-yellow lead to the same length as the black-green lead and prepare the end of this lead as before. Then twist these leads together loosely and connect both to lug 1 of terminal strip BD (S-2).
- ~~( )~~ Connect the black lead to lug 2 of terminal strip BD (NS).
- ~~( )~~ Connect the black-red lead to lug 6 of socket BE (NS).

## COMPONENT WIRING

- ~~(X)~~ Connect a 220  $\Omega$  (red-red-brown) resistor between lugs 2 (NS) and 3 (NS) of terminal strip E.
- ~~( )~~ Connect a 10  $\Omega$  (brown-black-black) resistor between lugs 1 (NS) and 2 (NS) of terminal strip E.
- ~~(X)~~ Connect either positive (+) lead of a 20-20  $\mu$ fd electrolytic capacitor to lug 2 (S-3) and the other positive (+) lead to lug 3 (S-2) of terminal strip E.
- ~~(X)~~ Connect the remaining lead of this capacitor to lug 2 of terminal strip F (S-3).
- ~~(X)~~ Connect the cathode lead of a silicon diode to lug 1 of terminal strip E (S-2) and the other lead to lug 1 of terminal strip F (S-2). See Detail 3B.

NOTE: WHEN INSTALLING SILICON DIODES, THE CATHODE END MUST BE PLACED AS DIRECTED. THE CATHODE END IS MARKED WITH EITHER A COLOR END, COLOR DOT, COLOR BAND, OR BY THE FLAT END OF THE DIODE. IN THE ILLUSTRATION, THE SYMBOL K INDICATES THE CATHODE END.

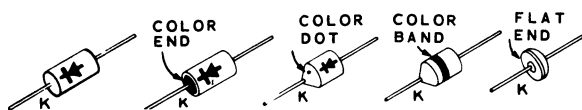

Detail 3B

- (X) Connect the cathode lead of a silicon diode to lug 4 of terminal strip E (NS) and the other lead to lug 3 of terminal strip F (S-1).
- (X) Connect the cathode lead of a silicon diode to lug 4 of terminal strip F (NS) and the other lead to lug 4 of terminal strip E (S-2).
- (X) Connect the cathode lead of a silicon diode to lug 5 of terminal strip E (NS) and the other lead to lug 4 of terminal strip F (S-3).
- (X) Connect the cathode lead of a silicon diode to lug 5 of terminal strip F (NS) and the other lead to lug 5 of terminal strip E (S-2).
- (X) Connect the positive (+) lead of a 40  $\mu$ fd tubular electrolytic capacitor to lug 2 of terminal strip G (NS). Connect the other lead to lug 1 of electrolytic capacitor K (NS). Use a 3/4" length of sleeving on the lead to K.
- (X) Connect the positive (+) lead of a 40  $\mu$ fd tubular electrolytic capacitor to lug 3 of terminal strip G (NS). Place a 3/4" length of sleeving on the other lead and connect it to lug 2 of electrolytic capacitor K (NS).
- (X) Connect a 100 K $\Omega$  (brown-black-yellow) 2 watt resistor between lug 1 (NS) and the mounting foot eyelet of terminal strip G (S-1).
- (X) Connect a 100 K $\Omega$  (brown-black-yellow) 2 watt resistor from lug 5 of terminal strip F (S-3) to lug 1 of terminal strip G (S-3).
- (X) Connect a 100  $\Omega$  wire-wound 7 watt resistor between lugs 2 (S-3) and 3 (S-4) of terminal strip G.
- (X) Connect a 270  $\Omega$  (red-violet-brown) 2 watt resistor between lugs 1 (S-4) and 2 (NS) of electrolytic capacitor K.
- (X) Connect one lead of the circuit breaker to lug 3 of terminal strip BD (S-2). Connect the other circuit breaker lead to lug 2 of terminal strip BD (S-3) [S-2 for 240 VAC wiring].
- (X) Connect a .005  $\mu$ fd 1.4 KV disc capacitor between lugs 6 (NS) and 9 (S-1) of socket BE.
- (X) Connect a .005  $\mu$ fd 1.4 KV disc capacitor between lugs 4 (S-1) and 5 (NS) of terminal strip BD.
- (X) Connect a 100  $\mu$ fd disc capacitor between lugs 2 (NS) and 3 (S-1) of terminal strip C. Position as shown.
- (X) Connect one lead of a .001  $\mu$ fd disc capacitor through the center post (S-3) to lug 8 (S-1) of tube socket V5. Connect the other lead to lug 2 of V5 (S-2).
- (X) Connect a length of small bare wire from solder lug EC (NS), through lug 5 (S-2) to the center post (S-2) of tube socket V4.
- (X) Connect a 22 megohm (red-red-blue) resistor from solder lug EC (S-2) to lug 7 of tube socket V4 (NS).
- (X) Connect a 3300  $\Omega$  (orange-orange-red) resistor from lug 3 of tube socket V5 (S-1) to solder lug EB (S-1).
- (X) Connect a 470 K $\Omega$  (yellow-violet-yellow) resistor from lug 6 of tube socket V5 (NS) to lug 4 of terminal strip C (NS).
- (X) Connect a 470 K $\Omega$  (yellow-violet-yellow) resistor from lug 1 of tube socket V5 (NS) to lug 4 of terminal strip C (NS).
- (X) Connect a 33 K $\Omega$  (orange-orange-orange) resistor from lug 4 of terminal strip C (NS) to lug 4 of terminal strip A (NS).

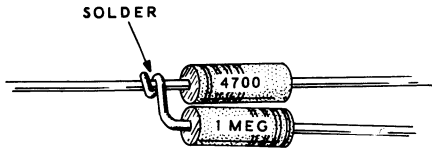

Detail 3C

- (X) Prepare a resistor combination using a 1 megohm (brown-black-green) resistor and a 4700  $\Omega$  (yellow-violet-red) resistor as shown in Detail 3C.
- (X) Connect the common lead of this combination to the center of microphone connector AA (S-1). Use 3/4" of sleeving.
- (X) Connect the free lead of the 1 megohm (brown-black-green) resistor to lug 2 of terminal strip A (S-2).
- (X) Place a 1-1/4" length of sleeving on the free lead of the 4700  $\Omega$  (yellow-violet-red) resistor and connect this lead to lug 2 of terminal strip C (S-3).
- (X) Connect a 10 K $\Omega$  (brown-black-orange) 2 watt resistor from lug 4 of terminal strip A (NS) to lug 1 of switch AB (S-1). Make sure the resistor lead does not touch the nut near lug 1 of the switch.
- (X) Connect the positive (+) lead of a 20  $\mu$ fd electrolytic capacitor to lug 4 of terminal strip C (S-4). Connect the other lead of this capacitor to lug 3 of control AC (S-2). Also, solder lug 3 of AC to the control solder lug.

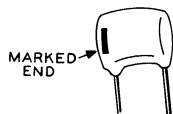

Detail 3D

NOTE: When installing Mylar capacitors, be sure to place the marked end as shown in the Pictorial. Detail 3D shows capacitor end marking.

- (X) Connect the lead at the marked end of a .005  $\mu$ fd Mylar capacitor to lug 6 of tube socket V5 (S-2). Connect the other lead to lug 3 of control D (S-1). Use a 1-1/4" length of sleeving on the lead to V5.

- (X) Connect the lead at the marked end of a .005  $\mu$ fd Mylar capacitor to lug 1 of tube socket V5 (S-2). Connect the other lead to lug 7 of tube socket V4 (S-2). Use a 3/4" length of sleeving on each lead.

- (X) Connect a 6800  $\Omega$  (blue-gray-red) 2 watt resistor from lug 4 of terminal strip A (S-4) to lug 1 of control AC (S-1). Use a 1" length of sleeving on each lead.

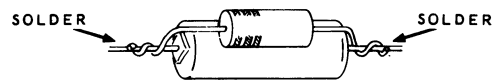

Detail 3E

- (X) Prepare a 47 K $\Omega$  (yellow-violet-orange) 2 watt resistor and .1  $\mu$ fd tubular capacitor combination as shown in Detail 3E.

- (X) Connect this combination from lug 9 of tube socket V4 (S-3) to lug 2 of switch AB (S-1). Use a 1-1/8" length of sleeving on each lead.

- (X) Connect a .005  $\mu$ fd disc capacitor from solder lug EE (S-2), through lug 4 (S-2) to the center post (NS) of tube socket V1. Connect the other lead to lug 5 of V1 (S-3).

- (X) Insert one lead of a 100  $\mu$ fd disc capacitor through lug 7 (S-2), through the center post (S-3) to lug 1 (S-1) of tube socket V1. Connect the other lead to lug 8 of V1 (NS).

- (X) Connect a .005  $\mu$ fd disc capacitor between lugs 1 (NS) and 2 (NS) of terminal strip M.

- (X) Connect a .005  $\mu$ fd disc capacitor between lugs 2 (NS) and 4 (NS) of terminal strip M.

- (X) Connect a 15 K $\Omega$  (brown-green-orange) 2 watt resistor from lug 3 of terminal strip M (NS) to lug 8 of tube socket V1 (NS). Position the resistor away from the mounting hole near M.



- (X) Connect a 47 K $\Omega$  (yellow-violet-orange) resistor from lug 4 of terminal strip M (NS) to lug 9 of tube socket V1 (S-1). Use a 3/4" length of sleeving on the lead to V1.
- (X) Connect a 33 K $\Omega$  (orange-orange-orange) resistor between lugs 2 (S-3) and 4 (S-5) of terminal strip M.
- (X) Connect a 1000  $\Omega$  (brown-black-red) 1 watt resistor between lugs 1 (NS) and 3 (S-4) of terminal strip M.
- (X) Connect a .005  $\mu$ fd disc capacitor between lugs 3 (NS) and 4 (NS) of terminal strip N.
- (X) Connect a .005  $\mu$ fd disc capacitor between lugs 4 (NS) and 5 (NS) of terminal strip N.
- (X) Connect an 820  $\Omega$  (gray-red-brown) resistor between lugs 5 (NS) and 6 (NS) of terminal strip N.
- (X) Connect another 820  $\Omega$  (gray-red-brown) resistor between lugs 5 (NS) and 6 (NS) of terminal strip N.
- (X) Connect a 4700  $\Omega$  (yellow-violet-red) 1 watt resistor between lugs 2 (S-3) and 6 (S-4) of terminal strip N.
- (X) Insert one lead of a .005  $\mu$ fd disc capacitor through solder lug ED (S-2), through lug 4 (S-2) to the center post (NS) of tube socket V2. Connect the other lead to lug 5 of V2 (S-2).
- (X) Insert one lead of a .005  $\mu$ fd disc capacitor through lug 7 (S-2), through the center post (S-3) to lug 1 (S-1) of tube socket V2. Connect the other lead to lug 8 of V2 (S-2).
- (X) Connect a .005  $\mu$ fd disc capacitor between lugs 2 (S-1) and 3 (NS) of terminal strip L.
- (X) Connect an 18 K $\Omega$  (brown-gray-orange) resistor between lugs 1 (S-2) and 3 (NS) of terminal strip L.
- (X) Connect an RF choke (#45-3) from lug 3 of terminal strip L (S-3) to lug 9 of tube socket V2 (NS).

NOTE: When installing the following components, keep the leads as short as possible.

- (X) Connect a .005  $\mu$ fd disc capacitor between lugs 1 (S-1) and ground lug 9 (NS) of tube socket V3.
- (X) Connect a .005  $\mu$ fd disc capacitor between lugs 2 (S-2) and ground lug 9 (S-2) of tube socket V3.
- (X) Connect a .005  $\mu$ fd disc capacitor between lugs 3 (S-2) and ground lug 10 (NS) of tube socket V3.
- (X) Connect a .005  $\mu$ fd disc capacitor between lugs 4 (S-1) and ground lug 10 (S-2) of tube socket V3.
- (X) Connect a .005  $\mu$ fd disc capacitor between lugs 6 (NS) and ground lug 11 (S-1) of tube socket V3.
- (X) Connect an 8.2  $\Omega$  (gray-red-gold) resistor between lugs 6 (S-3) and ground lug 12 (S-2) of tube socket V3.

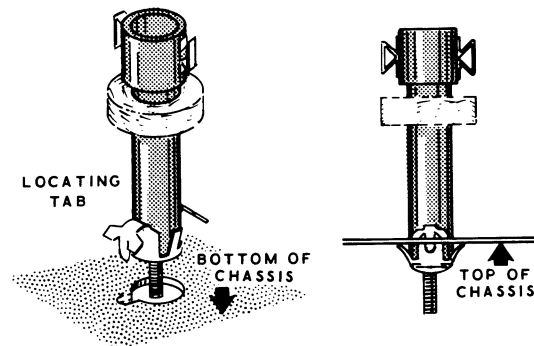

Detail 3F

- (X) Referring to Detail 3F, mount the driver coil (#40-79) at CA. Position the locating tab in the slot.
- (X) Connect a length of small bare wire from lug 1 of terminal strip M (S-3) to lug 1 of coil CA (S-1).
- (X) Connect a length of small bare wire from lug 2 of coil CA (NS) to lug 6 of tube socket V1 (S-1).
- (X) Connect one lead of a 47  $\mu$ mf silver mica capacitor to lug 2 of coil CA (S-2). Use a 1-1/4" length of sleeving. Leave the other lead free.

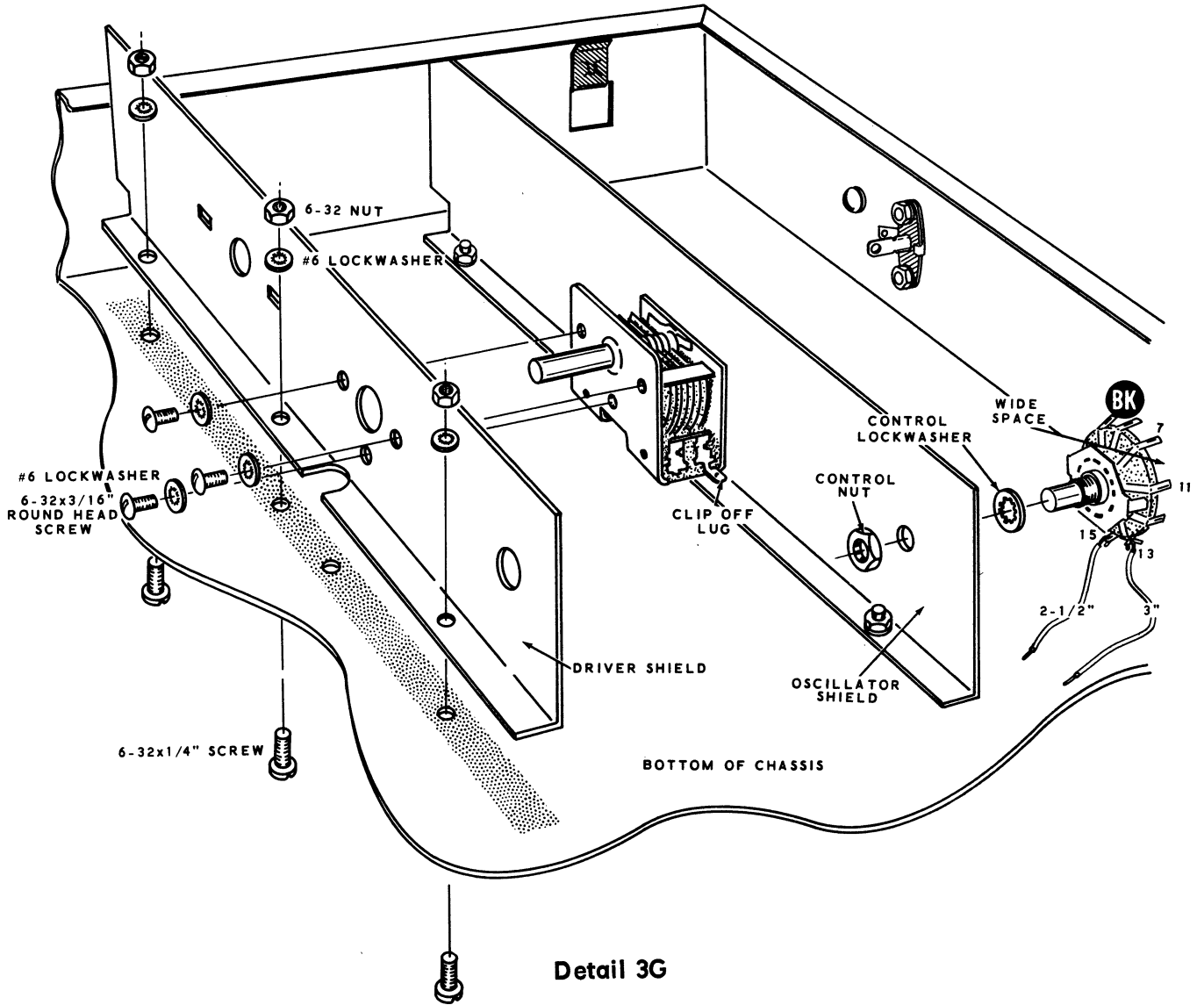

Detail 3G

**GENERAL CHASSIS ASSEMBLY**

In the following steps, keep the plates of the variable capacitor completely meshed to avoid damage.

Refer to Detail 3G for the following steps.

Mount the 1-section variable capacitor (#26-64) to the driver shield. Use 6-32 x 3/16" round head screws and #6 lockwashers. Also, clip off lug 1 of the capacitor.

- Install the driver shield and oscillator shield on the main chassis. Use 6-32 hardware. See Detail 3G and Pictorial 3.
- Locate the 1-wafer rotary switch (#63-290). Position the switch so the wide space between lugs 7 and 11 is as shown in Detail 3G.
- Connect a 3" small red wire to lug 13 of switch BK (S-1).
- Connect a 2-1/2" small red wire to lug 15 of switch BK (S-1).



(X) Mount the rotary switch on the oscillator shield. Use a control lockwasher and control nut. Position the wires as shown.

(X) Slip a 1-1/4" length of sleeving over the free lead of the capacitor coming from lug 2 of coil CA. Place this lead through the small hole in the oscillator shield and connect it to lug 9 of tube socket V2 (S-2).

Refer to Pictorial 3 for the following steps.

Wiring between rotary switch BK and the crystal sockets will be done in the following four steps. Use the small bare wire and sleeving. The sleeving length should be approximately 1/2" shorter than each wire length.

WIRE LENGTHS	FROM SWITCH LUGS	TO CRYSTAL SOCKET
(X) 2-1/4"	18 (S-1)	lug 1 of X4 (S-1).
(X) 2"	16 (S-1)	lug 1 of X3 (S-1).
(X) 1-3/4"	14 (S-1)	lug 1 of X2 (S-1).
(X) 1-1/2"	12 (S-1)	lug 1 of X1 (S-1).

(X) Connect the free end of the red wire coming from lug 13 of switch BK, to lug 4 of socket BE (S-1).

(X) Connect the free end of the red wire coming from lug 15 of switch BK, to lug 2 of electrolytic capacitor K (S-5).

(X) Connect a 3" small bare wire from lug 20 of switch BK (S-1) to lug 1 of phono connector BF (S-1). Use sleeving.

(X) Connect a 3" small bare wire from lug 22 of switch BK (S-1) to lug 2 of tube socket V1 (S-1).

(X) Connect a .001  $\mu$ fd disc capacitor between lugs 2 (NS) and 11 (S-1) of switch BK. Use a 3/4" length of sleeving on the lead to lug 2.

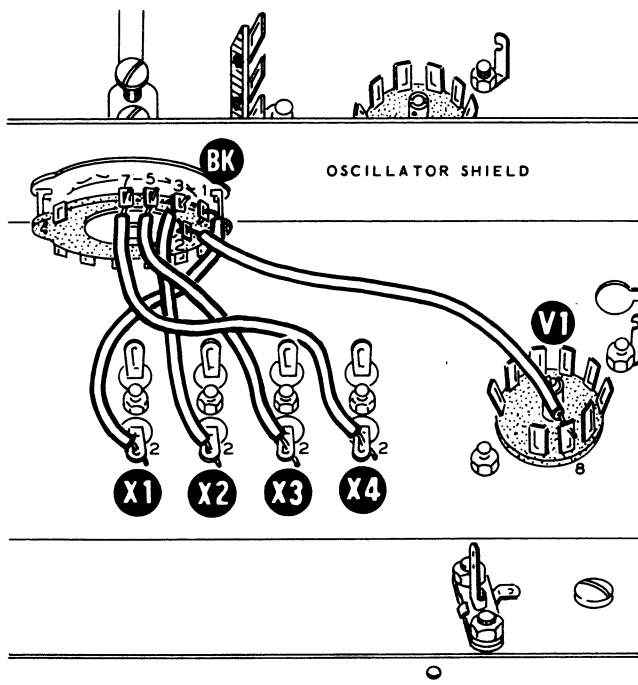

Detail 3H

Refer to Detail 3H for the following steps.

Wiring between rotary switch BK and the crystal sockets will be done in the following four steps. Use the small bare wire and sleeving. Be sure the sleeving length is approximately 1/2" shorter than each wire length.

WIRE LENGTHS	FROM SWITCH LUGS	TO CRYSTAL SOCKET
(X) 2"	1 (S-1)	lug 2 of X1 (S-1).
(X) 2"	3 (S-1)	lug 2 of X2 (S-1).
(X) 2-1/2"	5 (S-1)	lug 2 of X3 (S-1).
(X) 3"	7 (S-1)	lug 2 of X4 (S-1).

(X) Connect a 3-1/2" small bare wire from lug 2 of switch BK (S-2) to lug 8 of tube socket V1 (S-3). Use a 3" length of sleeving.

Check all wiring around the crystal sockets and switch BK for any loose or shorted connections.

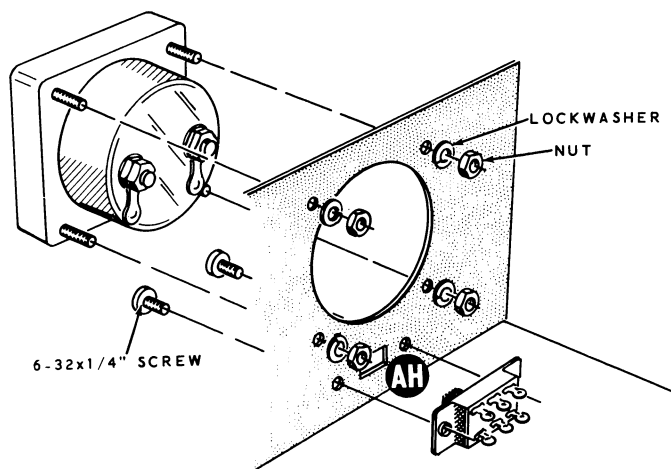

Detail 4A

### TOP OF CHASSIS ASSEMBLY AND WIRING

Refer to Detail 4A for the following steps.

- (X) Mount the slide switch (#60-15) on the front panel at AH. Use 6-32 x 1/4" screws.
- (X) Remove the meter from its box and remove the shorting wire from between the studs.

NOTE: The meter you receive may have the lugs turned in the direction opposite that shown in Detail 4A and Pictorial 4. However, do not attempt to turn the lugs because damage to the meter may result.

- (X) Mount the meter to the front panel. Use the lockwashers and nuts supplied with the meter. Be careful not to mount the meter upside down. Also, do not overtighten the nuts as the meter case may break.

Refer to Pictorial 4 for the following seven steps.

- (X) Connect the green wire coming from grommet B to lug 6 of switch AH (S-1).
- (X) Connect the yellow wire coming from grommet B to lug 3 of switch AH (S-1).
- (X) Connect the black wire coming from grommet B to lug 4 of switch AH (S-1).
- (X) Connect the gray wire coming from grommet B to lug 1 of switch AH (S-1).

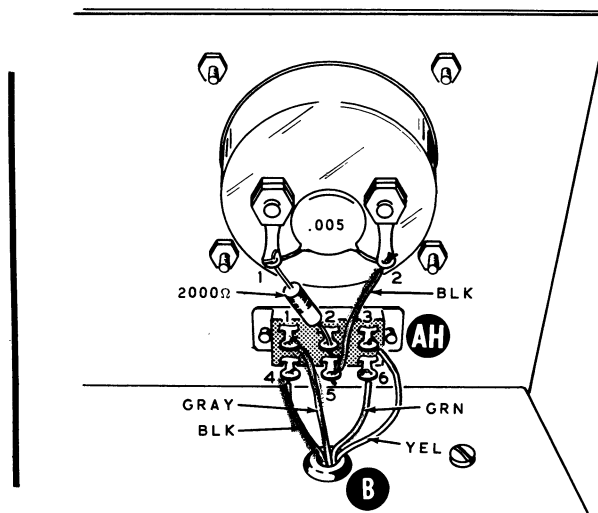

PICTORIAL 4

- (X) Connect one end of a 4" black wire from lug 5 of switch AH (S-1) to lug 2 of the meter (NS).
- (X) Connect a 2000  $\Omega$  (red-black-red) resistor from lug 2 of switch AH (S-1) to lug 1 of the meter (NS).
- (X) Connect a .005  $\mu$ fd disc capacitor between lugs 1 (S-2) and 2 (S-2) of the meter.

Refer to Pictorial 5 for the following steps.

NOTE: In the following steps, keep the plates of the variable capacitors completely meshed to avoid damage.

- (X) Locate the front shield (#206-271) and mount the 2-section variable capacitor (#26-102) at AM. Use 6-32 x 3/16" hardware.
- (X) Mount the 3-section variable capacitor (#26-101) at AL. Use 6-32 hardware.
- (X) Bend the lugs on one side of capacitor AL and AM as shown in the inset drawing on Pictorial 5.
- (X) Insert one end of a 5-3/4" large bare wire through lugs 1, 2, and 3 of capacitor AL. Now solder all three lugs. Make sure the wire does not touch the capacitor shield partitions.

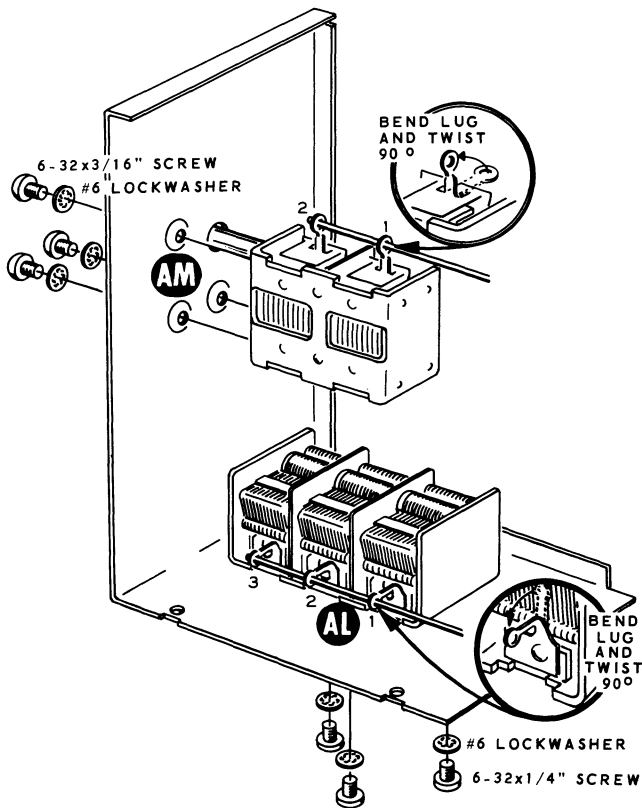

PICTORIAL 5

X) Insert one end of a 3-1/2" large bare wire through lugs 1 and 2 of capacitor AM. Now solder both lugs. Make sure the wire does not touch the capacitor shield partitions.

Refer to Pictorial 6 for the following steps.

X) Place the shield assembly in position on the chassis by inserting the two capacitor shafts through the front panel holes, and the bare wire from capacitor AM through grommet Q.

X) Fasten the shield to the chassis as shown in the inset drawing with 6-32 spade bolts, #6 lockwashers, and 6-32 nuts. Position the offset on each spade bolt as shown.

X) Mount RF choke (#45-41) at T. Use a 6-32 x 3/8" screw and two #6 solder lugs. Position the solder lugs as shown in the Pictorial. Also, do not overtighten the screw as you might crack the choke form.

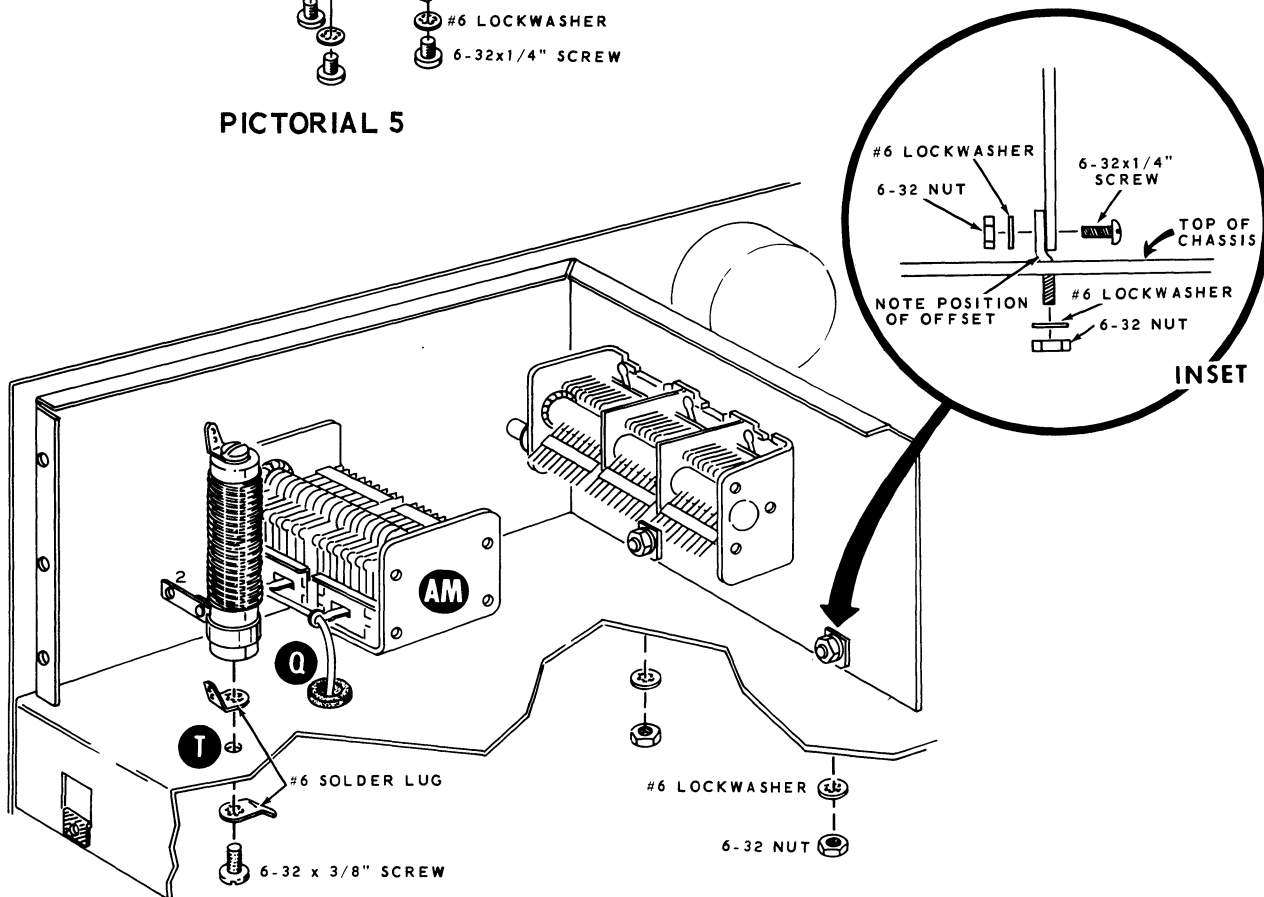

PICTORIAL 6

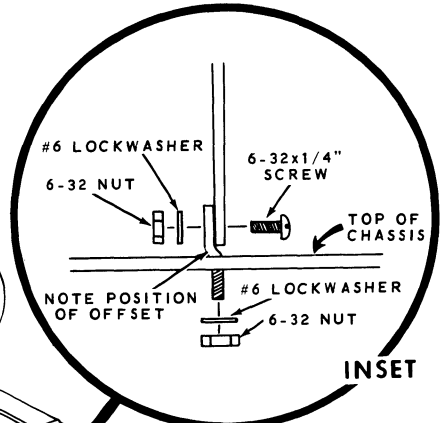

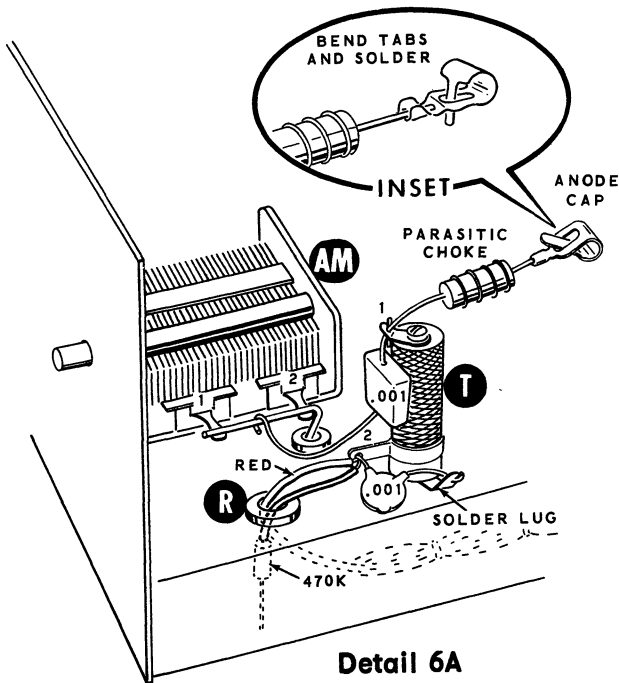

Detail 6A

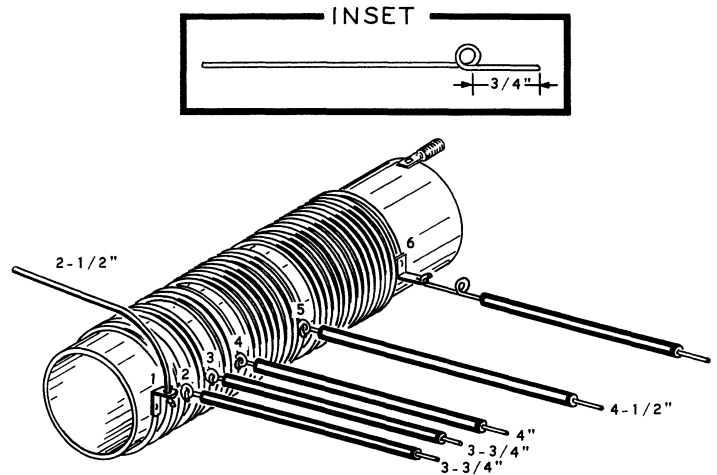

Detail 7A

Refer to Detail 6A for the following steps.

- ~~(X)~~ Place a 1" length of sleeving on one lead of a 470 KΩ (yellow-violet-yellow) resistor. Insert this lead through grommet R and connect it to lug 2 of choke T (NS).
- ~~(X)~~ Connect the red wire coming through grommet R to lug 2 of choke T (NS).
- ~~(X)~~ Connect a .001 μfd 1.4 KV disc capacitor from lug 2 of choke T (S-3) to the solder lug at T (S-1).
- ~~(X)~~ Connect a .001 μfd molded mica capacitor from lug 1 of choke T (NS) to the bare wire going through lugs 1 and 2 of capacitor AM (S-1).
- ~~(X)~~ Cut both leads of parasitic choke (#45-19) to 3/4". Solder either lead to the anode cap. (See the inset drawing.) Connect the other lead to lug 1 of coil T (S-2).

Set the chassis aside temporarily.

- ( ) Locate final amplifier coil (#40-644). Connect the following lengths of large bare wire to the coil as shown in Detail 7A. Use sleeving on the wires and position the wires as shown.

WIRE LENGTH	SLEEVING LENGTH	COIL LUG
<del>(X)</del> 2-1/2"		1 (S-1).
<del>(X)</del> 3-3/4"	3-1/4"	2 (S-1).
<del>(X)</del> 3-3/4"	3-1/4"	3 (S-1).
<del>(X)</del> 4"	3-1/2"	4 (S-1).
<del>(X)</del> 4-1/2"	4"	5 (S-1).

- ~~(X)~~ Cut a 6" large bare wire. Approximately 3/4" from one end of the wire make an open loop as shown in the inset drawing on Detail 7A.

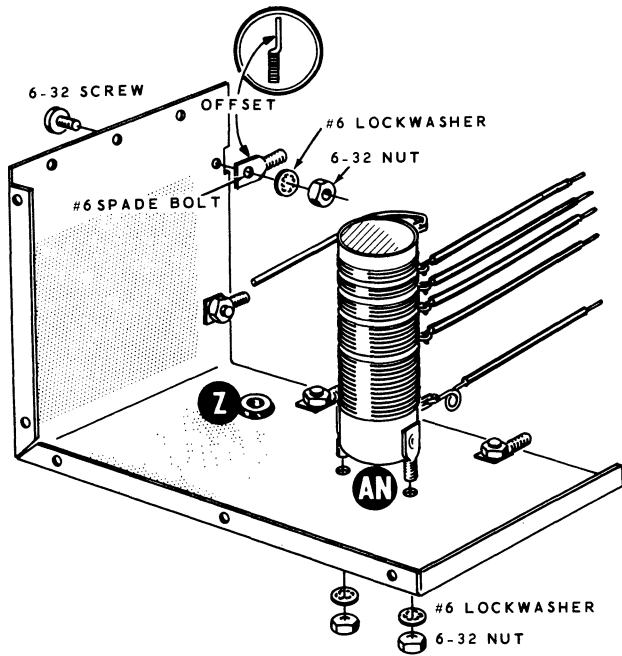

PICTORIAL 7

✗ Connect this end of the wire to lug 6 of the final amplifier coil (S-1). Use sleeving on the long end of the wire.

Refer to Pictorial 7 for the following steps.

- ✗ Locate the rear shield and position it as shown. Mount the final amplifier coil at AN. Use #6 lockwashers and 6-32 nuts.
- ✗ Mount four 6-32 spade bolts to the shield. Use 6-32 hardware. Position the offset of each spade bolt as shown.
- ✗ Install a 5/16" grommet at Z.

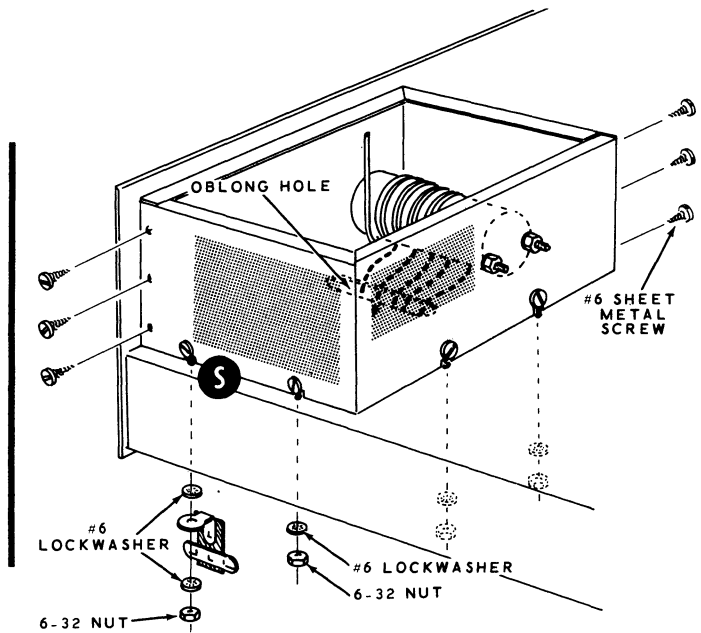

PICTORIAL 8

Refer to Pictorial 8 for the following steps.

- ✗ Mount the shield assembly to the chassis by inserting the spade bolts through the chassis holes and the five coil wires through the large oblong hole.
- ✗ Fasten the two amplifier shields together, using six #6 sheet metal screws.
- ✗ Install a 2-lug upright terminal strip on the spade bolt at S. Use #6 lockwashers and 6-32 nuts.
- ✗ Install #6 lockwashers and 6-32 nuts on the three remaining spade bolts.

Set the chassis aside temporarily.

### LOW-PASS FILTER ASSEMBLY

Refer to Pictorial 9 for the following steps.

- ( ) Mount a phono connector at DA. Use 6-32 hardware.
- (X) Mount a 3-lug terminal strip at DE. Use 6-32 hardware.
- (X) Mount a 2-lug terminal strip (one lug ground) at DB. Use 6-32 hardware.
- (X) Mount the center shield to the filter chassis. Use 6-32 hardware at DD and a 2-lug high voltage terminal strip with 6-32 hardware at DC.
- (X) Mount four 6-32 spade bolts to the side panels. Use 6-32 hardware. Position the offset of each spade bolt as shown.

Refer to Pictorial 10 for the following steps.

- (X) Connect a 47  $\mu\mu\text{f}$  silver mica capacitor between lugs 1 (S-1) and 2 (NS) of terminal strip DB.

NOTE: The eyelet in the middle of terminal strip DC will be referred to as lug 2, whenever wiring to this eyelet is performed.

- (X) Connect a 180  $\mu\mu\text{f}$  silver mica capacitor between lugs 1 (NS) and 2 (NS) of terminal strip DC.
- (X) Connect a 180  $\mu\mu\text{f}$  silver mica capacitor between lugs 2 (S-2) and 3 (NS) of terminal strip DC.
- ( ) Connect a 47  $\mu\mu\text{f}$  silver mica capacitor between lugs 1 (NS) and 2 (S-1) of terminal strip DE.

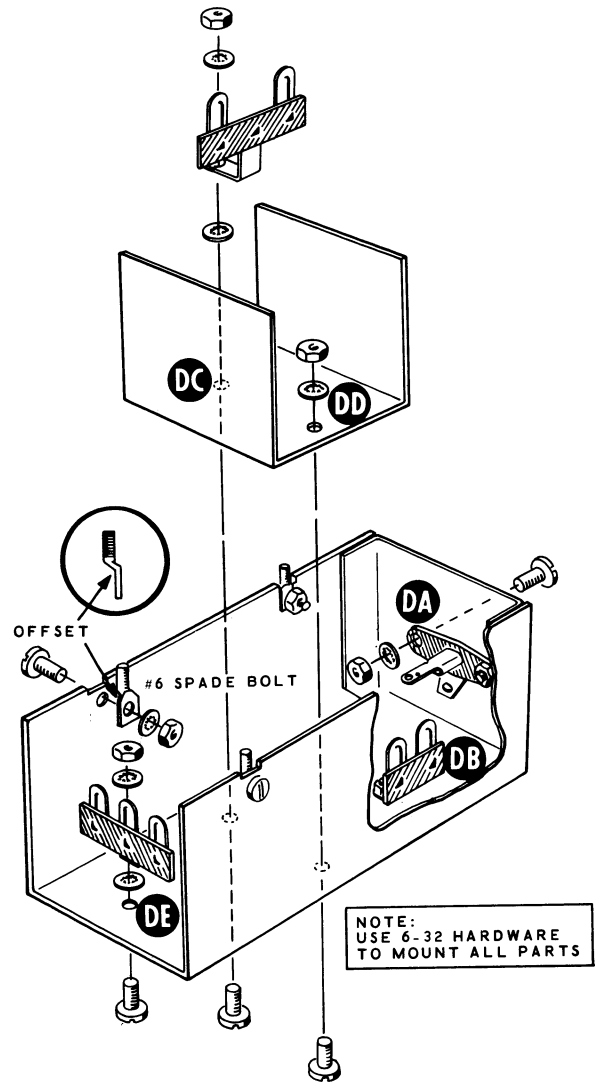

PICTORIAL 9

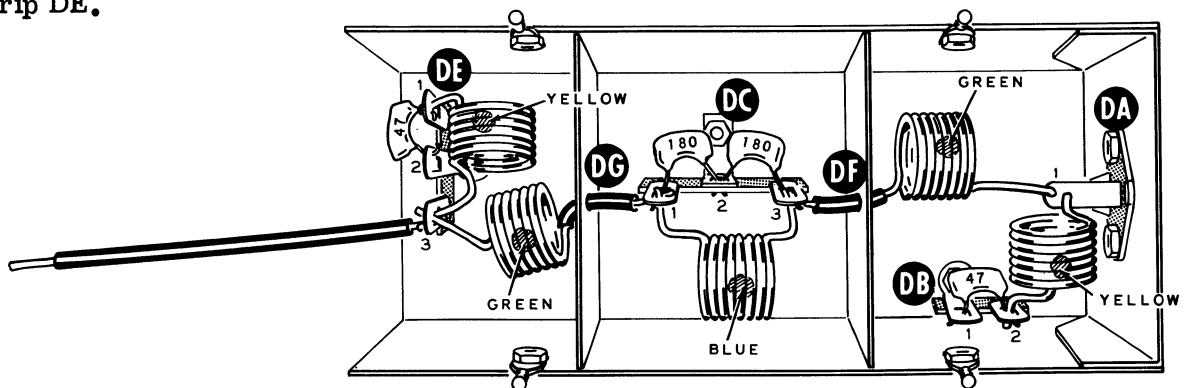

PICTORIAL 10

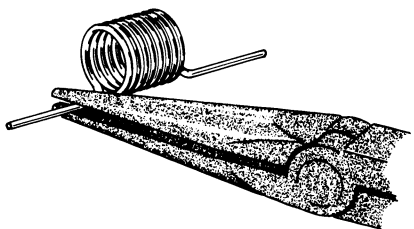

Detail 10A

The low-pass filter coils will be installed in the following steps. Bend the ends of the coils to the approximate shape shown in the Pictorial. This can be done by holding the coil with a pair of long-nose pliers as shown in Detail 10A. Then bend the ends of the coil with your finger. Also, do not attempt to bend the coil lead around the lugs to make a connection; merely insert it into the lug opening and follow the soldering instructions.

- (X) Connect a yellow marked coil (#40-347) between lugs 1 (S-2) and 3 (NS) of terminal strip DE. Position the coil so it does not touch lug 2 of the terminal strip.
- (X) Connect a yellow marked coil (#40-347) from lug 2 of terminal strip DB (S-2) to lug 1 of phono connector DA (NS).

- (X) Place a 1/2" length of sleeving on one lead of a green marked coil (#40-348). Position this lead through hole DF and connect it to lug 3 of terminal strip DC (NS). Connect the other lead to lug 1 of phono connector DA (S-2).
- (X) Place a 1/2" length of sleeving on one lead of a green marked coil (#40-348). Position this lead through hole DG and connect it to lug 1 of terminal strip DC (NS). Connect the other lead to lug 3 of terminal strip DE (NS).
- (X) Connect a blue marked coil (#40-349) between lugs 1 (S-3) and 3 (S-3) of terminal strip DC.
- (X) Connect a 4-1/2" large bare wire to lug 3 of terminal strip DE (S-3). Use sleeving on this wire.
- (X) Carefully inspect the wiring for any unsoldered, or loose connections. Also, make sure the coils are not touching the chassis.
- (X) Refer to Pictorial 11 and mount the filter assembly to the top of the chassis. Position the wire from the assembly through grommet Z. Secure the assembly to the chassis, using #6 lockwashers and 6-32 nuts on the spade bolts.

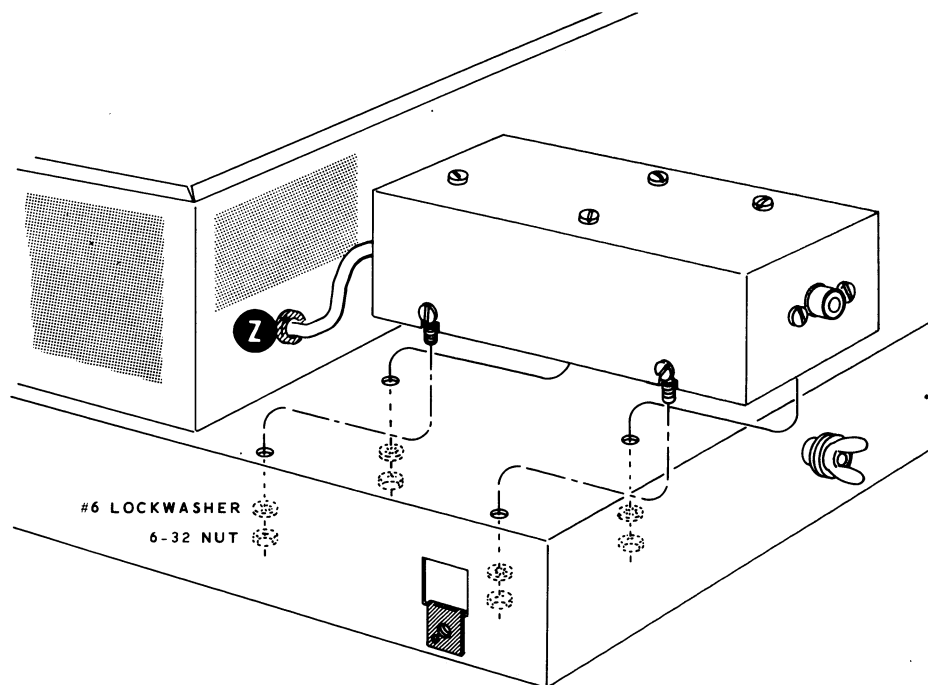

PICTORIAL 11

Refer to Pictorial 12 for the following steps.

- ✗) Connect the wire coming from variable capacitor AL to the loop in the wire near lug 6 of final tank coil AN (NS).
- ✗) Connect the wire coming through grommet Z to the loop in the wire near lug 6 of final tank coil AN (S-2).
- ✗) Connect the wire coming from lug 1 of coil AN to lug 1 (S-2) and lug 2 (S-1) of variable capacitor AM. Position this wire on top of the lugs as shown. Cut off any excess wire.

**FINAL WIRING**

Refer to Pictorial 13 (fold-out from Page 33) for the following steps.

- ✗) Mount the key jack at AG. Use a thin control lockwasher, control flat washer, and control nut. Position the key jack as shown in the Pictorial.
- ✗) Connect either lead of the red neon lamp to lug 1 of terminal strip S (S-1). Use a 3/4" length of sleeving. Connect the other lead through lug 1 (S-2) to lug 2 (S-1) of key jack AG.
- ✗) Connect the yellow harness wire coming from breakout point K to lug 3 of key jack AG (S-1).
- ✗) Connect the free lead of the 470 KΩ resistor coming through grommet R to lug 2 of terminal strip S (S-1).
- ( ✗) Locate the 2-wafer rotary switch (#63-244). Remove the rear wafer and set it aside temporarily.
- ✗) Mount the rotary switch at AF. Use a control lockwasher, control flat washer, and control nut. Position the switch as shown in Pictorial 13.
- ( ) Connect a 68 μμf 4 kv disc ceramic capacitor from lug 5 of switch AF (S-1) to solder lug T (S-1).

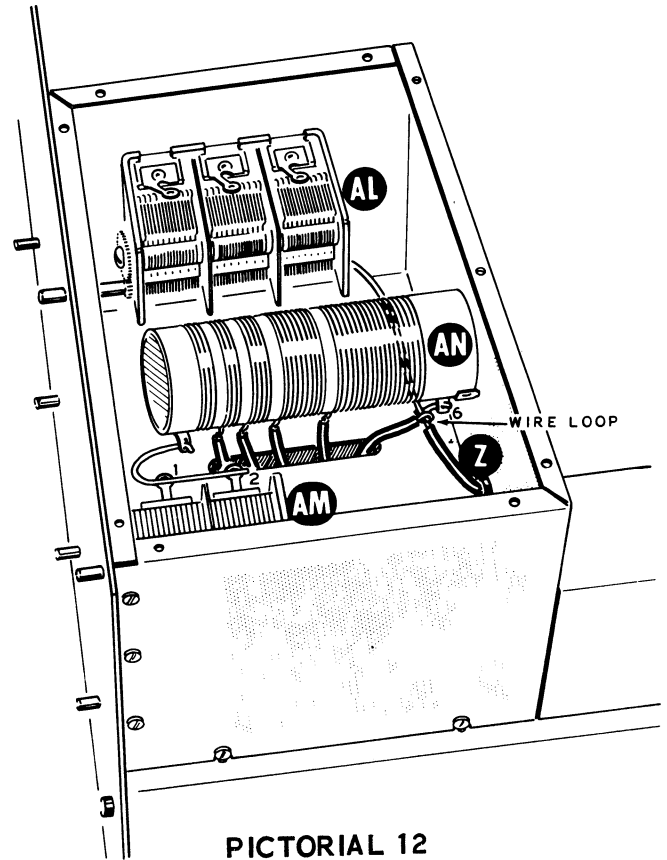

**PICTORIAL 12**

NOTE: In the following steps, insert the ends of the large wires through the switch lugs; do not attempt to bend the wires around the lugs.

- ✗) Connect the free end of the wire extending through grommet Q to lug 6 of switch AF (S-1). After soldering the wire, position it in the middle of the grommet.
- ( ) Connect the final amplifier coil leads to switch AF as follows:

<u>COIL LEAD</u>	<u>CONNECT TO LUG</u>
✗) 2	8 (S-1).
✗) 3	9 (S-1).
✗) 4	10 (S-1).
✗) 5	11 (S-1).
✗) 6	12 (S-1).





- ⑦ Locate the driver plate coil (#40-337), and the wafer that was removed from the rotary switch.

Refer to Detail 13A for the following steps.

- ⑧ Twist each lead of the coil 90 degrees.

Install the coil on the switch wafer as follows.

- ⑨ Insert the six leads of the coil in the lugs on the rear of the switch wafer. Position the coil approximately  $1/4$ " away from the switch wafer as shown in the inset drawing on Detail 13A.

- ⑩ Solder lugs 1, 2, 3, and 4. Clip off the excess lead length.

- ⑪ Cut each lead of a  $100 \mu\text{mf}$  silver mica capacitor to  $3/4$ ". Connect one lead of this capacitor to lug 8 of the switch wafer (NS).

- ⑫ Connect one end of a  $2-1/2$ " small bare wire to lug 8 of the switch wafer (S-3).

- ⑬ Remove one nut and one lockwasher from each of the wafer mounting studs. This hardware will be used in the following step.

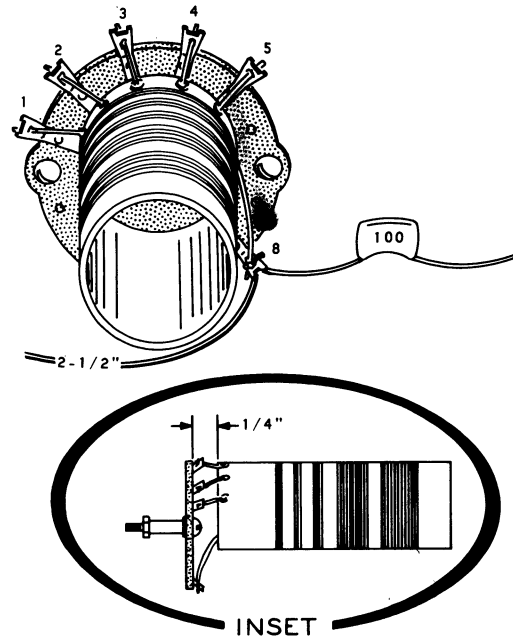

Detail 13A

- ⑭ Referring to Detail 13B, mount the wafer assembly to the driver shield at BJ. Use the hardware that was just removed from the wafer. Before sliding the wafer onto the bandswitch shaft, make sure the rotor key openings in the wafer and in the bandswitch, are pointed in the same direction.

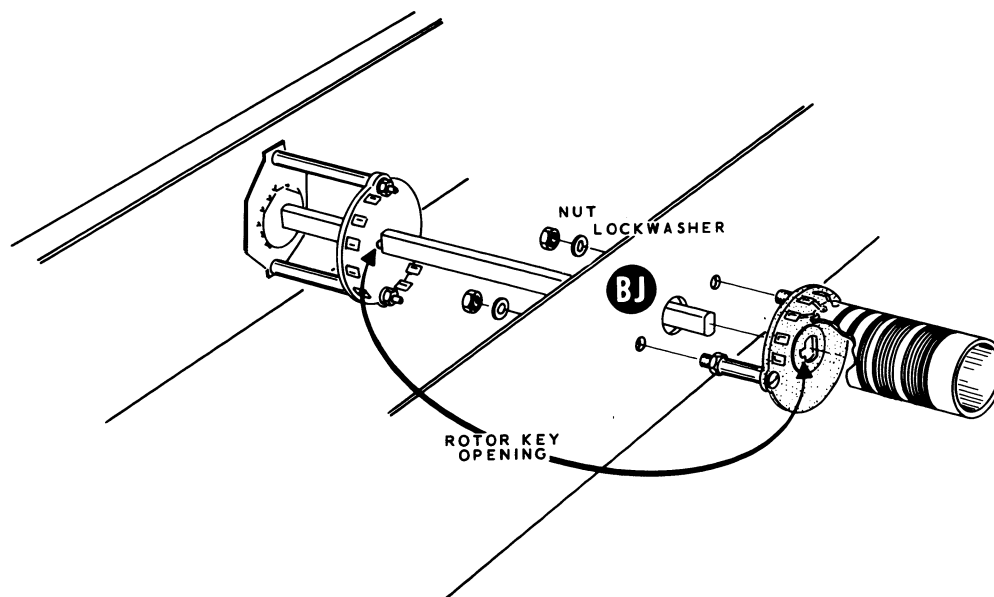

Detail 13B

- (X) Connect the free lead of the 100  $\mu\mu\text{f}$  silver mica capacitor coming from lug 8 of switch BJ to lug 1 of terminal strip N (NS).
- (X) Connect the free end of the bare wire coming from lug 8 of switch BJ to lug 2 of variable capacitor BH (NS). Use a 1-1/2" length of sleeving.
- (X) Connect a 2" small bare wire from lug 2 of variable capacitor BH (S-2) to lug 6 of tube socket V2 (S-1). Use sleeving.
- (X) Cut a 7" large bare wire. Referring to Detail 13C, make a small loop 1/2" from one end. Place a 6" length of sleeving on the long end of the wire and bend it as shown. This wire will be used as a neutralizing stub.

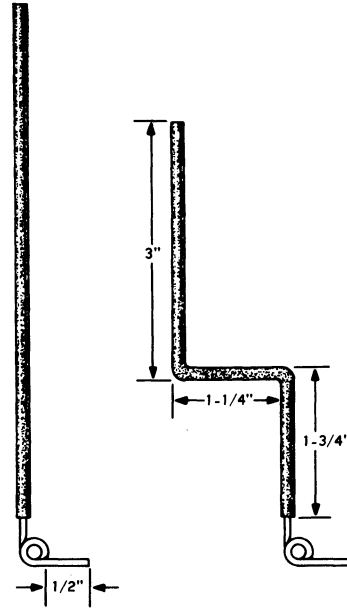

Detail 13C

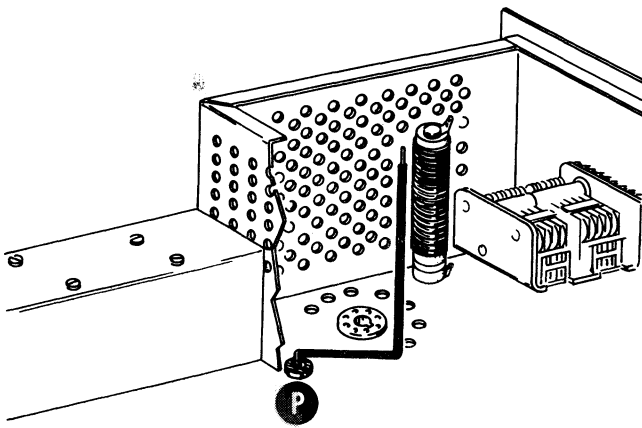

Detail 13D

- (X) Referring to Detail 13D, place the 1-3/4" end through grommet P from the top of the chassis.
- (X) Connect the end of the wire coming through grommet P to lug 5 of switch BJ (S-2).
- (X) Connect a 1000  $\Omega$  (brown-black-red) 2 watt resistor from the wire loop near lug 5 of switch BJ (NS) to lug 3 of terminal strip N (S-3).
- (X) Connect a 120  $\mu\mu\text{f}$  molded mica capacitor from the wire loop near lug 5 of switch BJ (S-2) to lug 4 of terminal strip N (S-3).
- (X) Connect a 1.1 mh choke (#45-4) between lugs 1 (S-3) and 5 (S-5) of terminal strip N.
- (X) Install a 1/4" coupler on the shaft of variable capacitor BH and rotary switch BK. Use 6-32 x 1/4" screws.
- (X) Install an 8" shaft through bushing AD, through the hole in the driver shield, to the coupler at BK. Use a 6-32 x 1/4" screw in the coupler.
- (X) Install a 5" shaft through bushing AE to the coupler at BH. Use a 6-32 x 1/4" screw in the coupler.
- (X) Position the line cord through hole BC. Connect one lead to lug 5 of terminal strip BD (S-3). Connect the other lead to lug 6 of socket BE (S-3).
- (X) Install the line cord strain relief in hole BC as shown in Detail 13E.

This completes the chassis wiring.

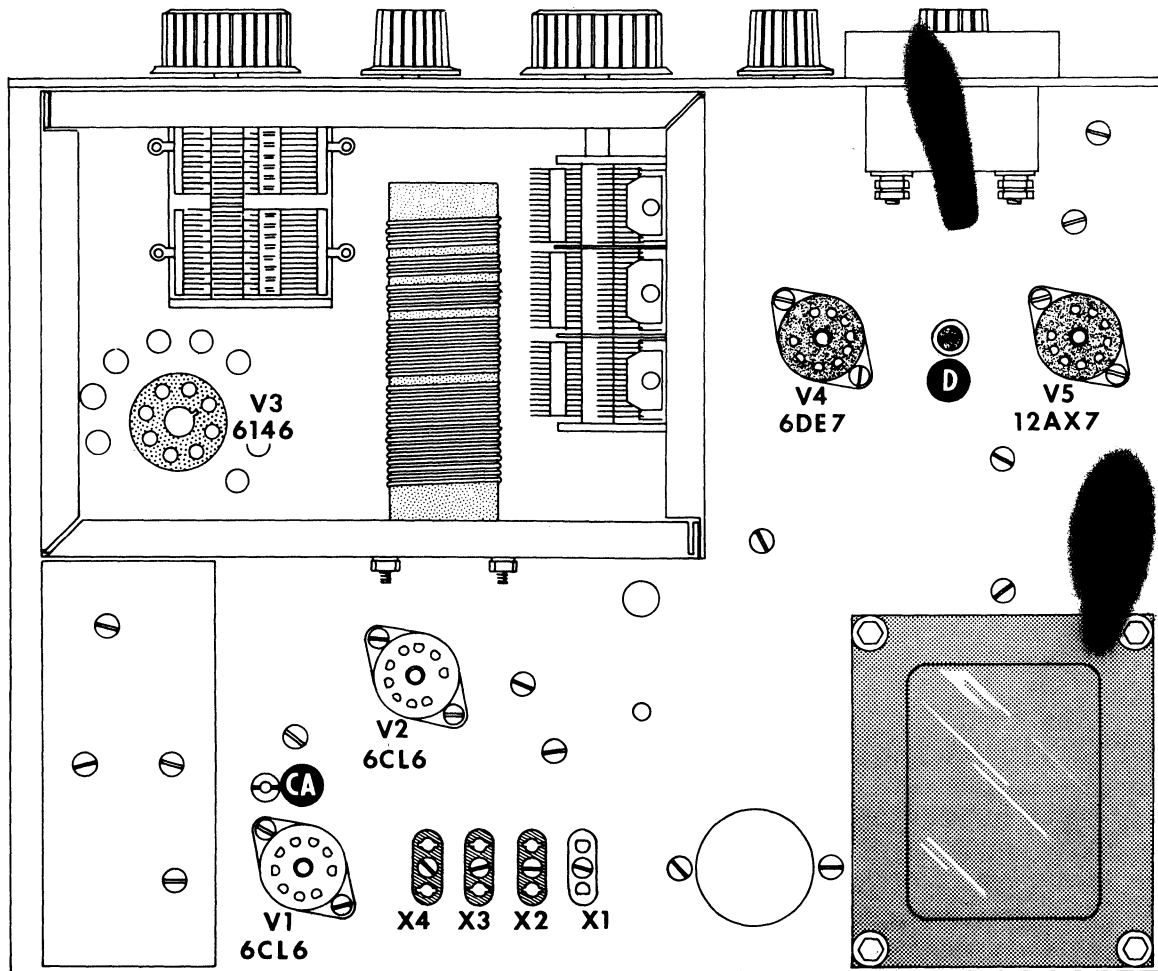

PICTORIAL 14

PLACE THE LINE CORD IN THE SLOT      SQUEEZE THE TWO SEGMENTS TOGETHER      INSERT THE REAR HALF INTO THE HOLE

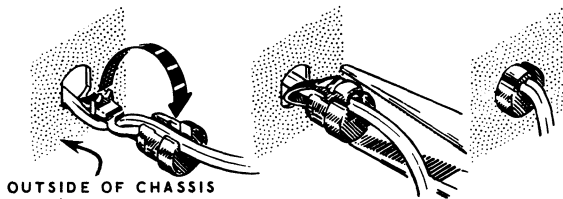

Detail 13E

Carefully inspect the wiring for any unsoldered connections, loose or broken leads, or shorted leads and lugs of tube sockets. Turn the chassis over and shake out any loose bits of solder or wire that may be lodged in the wiring.

(7) Referring to Pictorial 14, install the tubes in the sockets. Place the short tube shield on V5 and the remaining shields on V1, V2, and V4. Place the plate cap on V3.

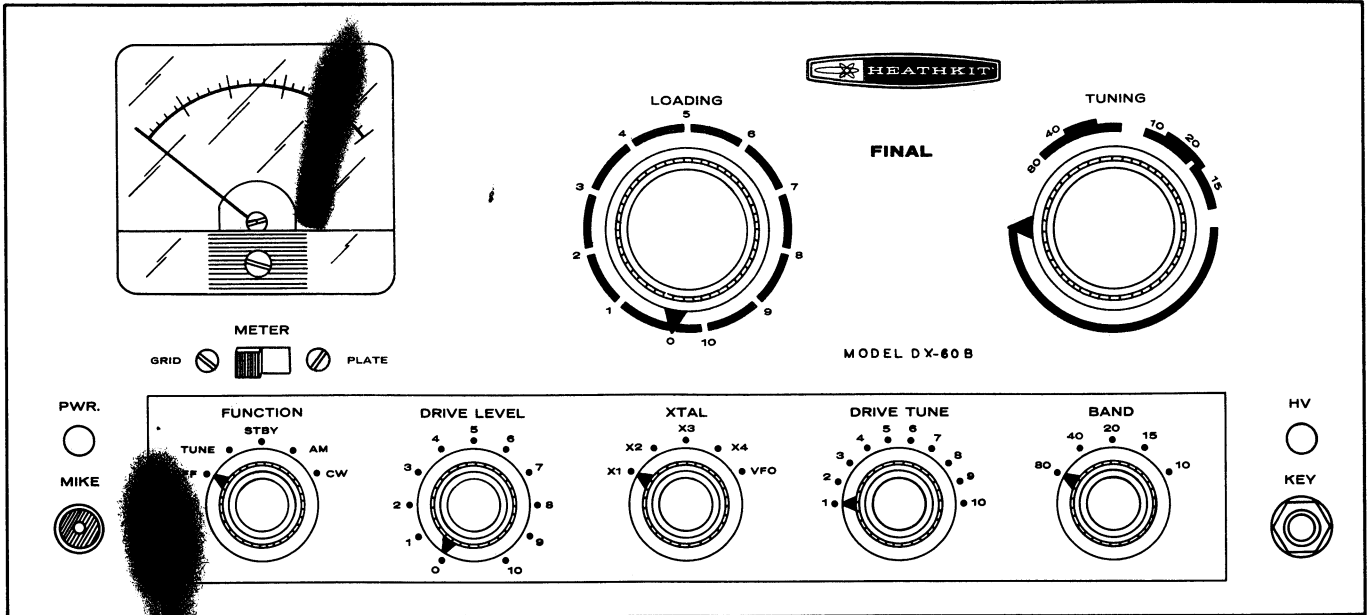

PICTORIAL 15

Refer to Pictorial 15 for the following steps.

- (X) Rotate the shafts of the Loading and Tuning capacitors counterclockwise. Install the two large knobs on the shafts with the pointers in the positions as shown.

- (X) Rotate the remaining five shafts counterclockwise. Install a small knob on each shaft with the pointers in the positions shown.

## INITIAL TEST AND ADJUSTMENT

- ( ) If an ohmmeter is available, measure the resistance from lug 1 of terminal strip G (+) to ground. The ohmmeter should "kick" down scale and then gradually rise to about 30 KΩ.
- ( ) Attach a resistive type dummy load to the antenna connector on the low-pass filter. The Heathkit Antenna Transmitter Dummy Load is such a type. If this type dummy load is not available, a dummy load constructed of a light bulb can be made as shown in Figure 2. The light bulb type dummy load may not work properly on all bands and therefore it is not recommended.
- ( ) Select a crystal, preferably an 80 meter crystal, and install it in crystal socket X1 or X2 (depending upon the diameter of the crystal socket pins).

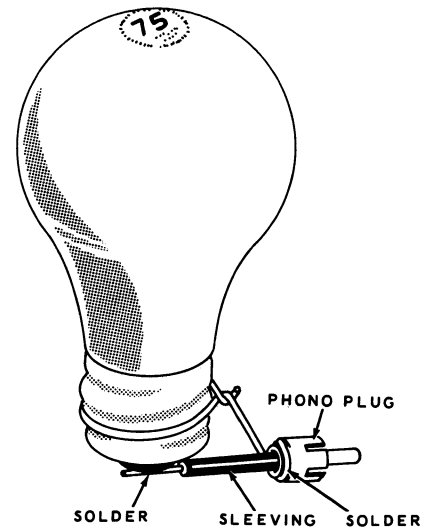

Figure 2



- ( ) Place all controls except FINAL TUNING in their maximum counterclockwise position. (The FINAL TUNING control should be set to the panel marking for the band being used, on this case the 80 meter position.)

WARNING: HIGH VOLTAGES ARE PRESENT BOTH ABOVE AND BELOW THE CHASSIS. CARE SHOULD BE EXERCISED NOT TO TOUCH ANY HIGH VOLTAGE POINTS WITH YOUR HANDS. WELL INSULATED TOOLS SHOULD BE USED FOR ANY ADJUSTMENTS BEHIND THE FRONT PANEL. ALWAYS REMOVE THE LINE CORD PLUG WHEN SERVICING THIS TRANSMITTER.

WARNING: BE SURE ALL CONTROLS ARE SET AS LISTED PREVIOUSLY.

- ( ) Plug the line cord into an AC outlet supplying the voltage for which the Transmitter was wired, 105-125 VAC or 210-250 VAC, 50/60 cps. CAUTION: Connecting the Transmitter to the wrong voltage could result in severe damage.
- ( ) Turn the FUNCTION switch to the STANDBY (STBY) position. The clear neon lamp and all tube filaments should light. If any overheating, arcing, or smoke is noticed, immediately unplug the transmitter from the AC outlet and refer to the In Case Of Difficulty section on Page 40.
- ( ) Turn the crystal switch to the X1 position. If an 80 meter crystal was installed in crystal socket X2, turn the crystal switch to the X2 position.
- ( ) Turn the FUNCTION switch to TUNE.
- ( ) Place the METER switch in the GRID position.

CAUTION: This transmitter produces more than sufficient grid drive on all bands. Be sure to reduce grid drive with the DRIVE LEVEL control when it exceeds 2.5 ma to prevent tube damage.

- ( ) Advance the DRIVE LEVEL control to 1. Now, adjust the DRIVE TUNE control for maximum reading on the meter. (If the meter pointer goes off scale, readjust the DRIVE LEVEL control setting.) After peaking the DRIVE TUNE control, set the DRIVE LEVEL control for a reading of 2.5 milliamperes.

- ( ) Return the Function switch to the STANDBY position.

WARNING: If you do not obtain a grid drive reading do not attempt to continue, since the final amplifier may be damaged. If at any point in the following steps the indicated results are not obtained, return the FUNCTION switch to STANDBY (STBY), and refer to the In Case Of Difficulty section on Page 40.

- ( ) Place the METER switch in the PLATE position.
- ( ) Turn the FUNCTION switch to the AM position and immediately adjust the FINAL TUNING control for a dip, or minimum plate current reading on the meter.
- ( ) Turn the FUNCTION switch to CW.
- ( ) Now advance the FINAL LOADING control approximately 1/8 turn. Readjust the FINAL TUNING control for a dip. Notice that the meter reading has increased slightly and possibly the dummy load will begin to glow.
- ( ) Alternately advance the FINAL LOADING control in 1/8 turn steps, and each time readjust the FINAL TUNING control for a dip in the meter reading. Repeat this procedure until the meter reading, when at the minimum point of the dip, reaches 150 ma.
- ( ) Place the METER switch in the GRID position and adjust the DRIVE LEVEL control for 2.5 ma. Return the METER switch to the PLATE position.
- ( ) Place the FUNCTION switch in the STANDBY position.
- ( ) Attach a crystal or other high impedance microphone to the MIKE jack. Turn the FUNCTION switch to the AM position and speak into the microphone. While speaking in a normal tone adjust the audio gain control (D), see Pictorial 14, until the meter peaks at approximately 75 ma. Now, return the FUNCTION switch to STANDBY.
- ( ) Repeat the preceding steps with the BAND switch in the 40, 20, 15, and 10 meter positions. We suggest that you use 40 meter crystals for these bands. The MIKE gain need not be readjusted once it is set unless the microphone is replaced.

(X) Set the BAND switch to 10 meters, the METER switch to the GRID position, and the XTAL switch to the position whose crystal socket should contain a 40 meter crystal that will multiply up to the center of the 10 meter band. Refer to Page 38 for crystal information.

(X) Place the FUNCTION switch in the TUNE position and adjust DRIVE TUNE for maximum drive, setting the DRIVE LEVEL for normal 2.5 ma grid drive. Now, adjust 40-meter driver coil CA for maximum indication on the meter. Reduce the drive if excessive. See Pictorial 14 on Page 33.

(X) Turn the transmitter off and remove the line cord plug from the AC outlet.

### NEUTRALIZATION ADJUSTMENT

Neutralization is generally necessary to assure stable operation of the final amplifier. This is accomplished by carefully adjusting the neutralizing stub in the amplifier compartment until an RF indicator, coupled to the final plate tank circuit (with high voltage disconnected!), reads minimum for resonant settings of both the DRIVE and FINAL tuning controls.

(X) Refer to Pictorial 2 (fold-out from Page 17). Disconnect the large red wire, coming from breakout E, from lug 3 of terminal strip G. Position this wire so it does not touch the chassis or any other parts. (This removes B+ from the plate of the final amplifier.)

(X) Plug the line cord into 117 V AC outlet.

( ) Select a crystal frequency near the center of the 10 meter band.

(X) Place the FUNCTION switch in the TUNE position and the METER switch in the GRID position.

(X) Adjust the DRIVE LEVEL and DRIVE TUNE control for a normal operating level.

( ) Loosely couple a grid dip meter to the 10 meter portion of the final tank coil, or connect the high impedance probe of a VTVM between the ANT connector and ground. Use a low AC range.

( ) Set the FINAL LOADING control to zero and set the FINAL TUNING control for a maximum reading on the RF indicator.

( ) Now, adjust the physical position of the neutralizing stub for a minimum reading on the RF indicator. Readjust the FINAL TUNING control for peak indication again, and also reposition the neutralizing stub for minimum RF indication. When the final amplifier has been neutralized, the FINAL TUNING capacitor can be rotated with very little variation in the RF indicator reading.

If an RF indicating device is not available a preset adjustment may be made as follows:

(X) With the line cord unplugged from the AC outlet, adjust the neutralizing stub so that it is approximately 1/4" from the final amplifier tube.

(X) Reconnect the large red wire to lug 3 of terminal strip G and solder.

If it becomes necessary to replace the final amplifier tube, be sure to recheck neutralization. If necessary to reneutralize, follow the neutralization procedure just completed.

### FINAL ASSEMBLY

Refer to Pictorial 16 for the following steps.

( ) Mount the top plate, using #6 sheet metal screws.

NOTE: In the following step, if the rubber feet furnished with your kit have flat steel washers molded into them, do not use any additional flat washers.

(X) Install four rubber feet on the bottom plate as shown in Pictorial 16. Use 6-32 x 3/8" screws, #8 flat steel washers, #6 lock-washers, and 6-32 nuts.

( ) Mount the bottom plate to the chassis with #6 sheet metal screws.

( ) Place the cabinet over the chassis and secure it on each side with two 6-32 x 1/4" black screws.

NOTE: The blue and white identification label shows the Model Number and Production Series Number of your kit. Refer to these numbers in any communications with the Heath Company; this assures you that you will receive the most complete and up-to-date information in return.

(X) Install the identification label in the following manner:

1. Select a location for the label where it can easily be seen when needed, but will not show when the unit is in operation. This location might be on the rear panel or the top of the chassis, or on the rear or bottom of the cabinet.
2. Carefully peel away the backing paper. Then press the label into position.

Before putting the Transmitter on the air, be sure to read the information in the Operation section which follows.

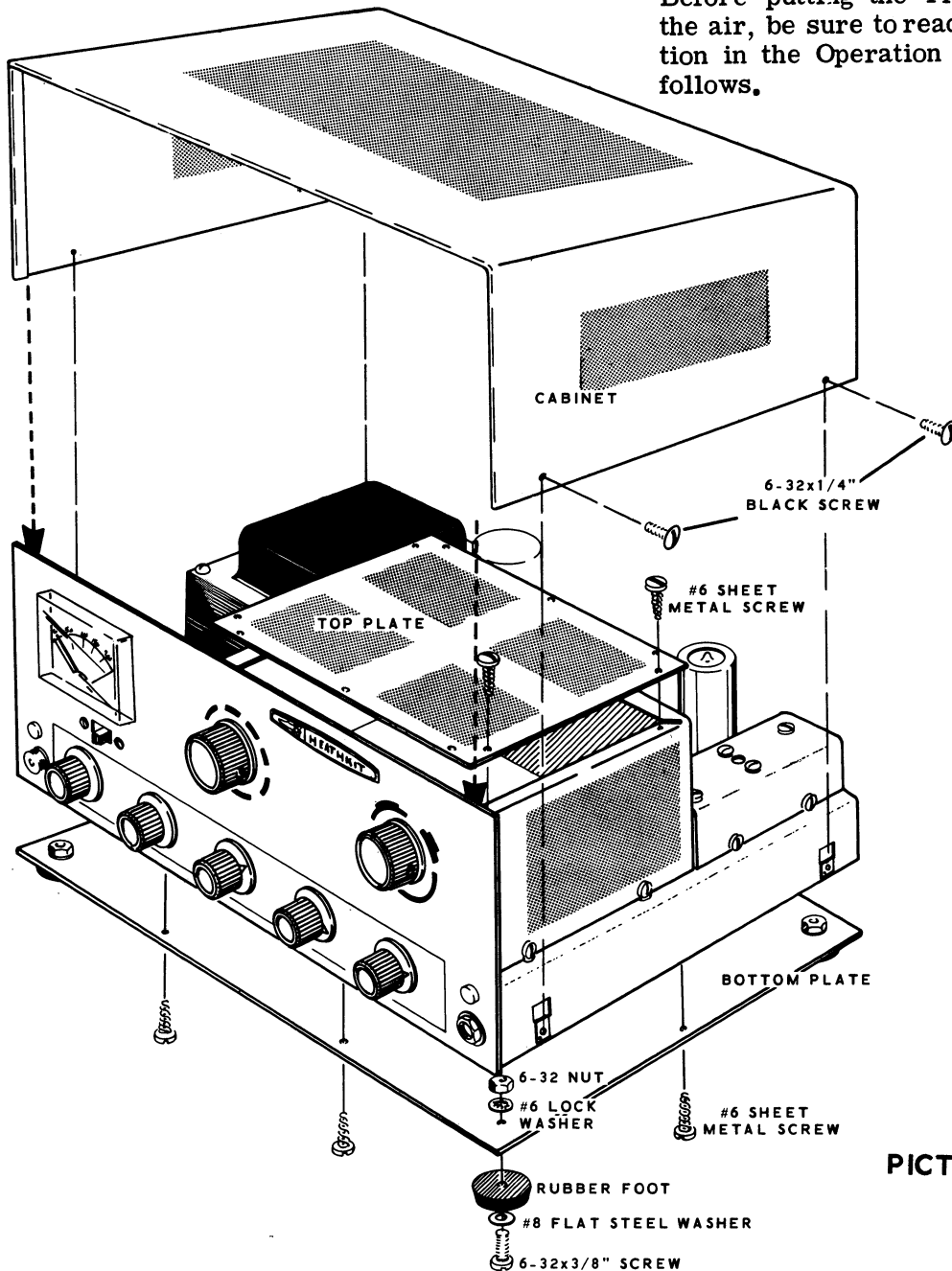

PICTORIAL 16







## OPERATING INSTRUCTIONS FOR CW OR AM

1. Plug the line cord into the AC outlet and check to be sure the antenna is connected.
2. Turn the FUNCTION switch to STBY.
3. Set the DRIVE LEVEL to about 2-1/2.
4. Select desired XTAL or VFO mode.
5. Select the desired BAND.
6. Set the FINAL TUNING capacitor in the desired band area as indicated on the front panel.
7. Set the FINAL LOADING control fully counterclockwise.
8. Set the METER switch to GRID position.
9. Turn the FUNCTION switch to TUNE.
10. Rotate the DRIVE TUNE control for maximum grid meter reading.
11. Set the DRIVE LEVEL to 2.5 ma of grid current.
12. Change METER switch to PLATE position.
13. Turn the FUNCTION switch to AM position.
14. Rotate the FINAL TUNING control to obtain a minimum plate current meter reading.
15. Turn the FUNCTION switch to CW.
16. While maintaining minimum plate current by tuning the FINAL TUNING control, increase the FINAL LOADING control in small steps in a clockwise direction until the Transmitter is loaded to 100 ma for Novice operation or 150 ma for regular operation.
17. Return the METER switch to GRID position.
18. Check and reset the grid drive to 2.5 ma if needed.
19. Return the FUNCTION switch to STBY.
20. Return the METER switch to PLATE position.

### CW

1. Insert key plug in key jack.
2. When ready to transmit turn the FUNCTION switch to CW and proceed. (NOTE: In the key-up position on CW, the final plate current will be approximately 5 to 20 ma.)

### AM

1. Remove key plug from key jack if in place.
2. Connect microphone.
3. When ready to transmit, turn the FUNCTION switch to AM and proceed.

## OPERATING REMINDERS

- A. If frequency changes of more than a few kilocycles occur, the final amplifier and driver stages may require retuning.
- B. Operation of the Transmitter without a crystal, a proper antenna, or dummy load will result in component failure.
- C. Operation of the Transmitter with the final amplifier not tuned to resonance (minimum plate current) may ruin the final amplifier tube.
- D. Use caution and observe rules of safety in making all voltage and current measurements.
- E. Do not cover cabinet ventilation holes.

## IN CASE OF DIFFICULTY

1. Recheck the wiring. Trace each lead in colored pencil on the Pictorial as it is checked. It is frequently helpful to have a friend check your work. Someone who is not familiar with the unit may notice something consistently overlooked by the constructor.
2. Check all solder connections carefully to make sure they are properly soldered. Be sure there are no solder bridges between two different foils. Usually a good solder connection is smooth and shiny. The wires are tightly soldered and cannot be pulled loose from the connection. It is interesting to note that about 90% of the kits that are returned to the Heath Company for repair, do not work properly due to poor solder connections. Reheat, and if necessary apply a little more solder, to all questionable connections.
3. Check to be sure that all tubes are in their proper locations. Make sure that all tubes light up properly.
4. Check the tubes with a tube tester or by substitution of tubes of the same types and known to be good.
5. Be sure the proper part is wired into the circuit in each position. Check the values of the resistors and capacitors. It is sometimes easy to misread the third color band on a resistor. For example, if a 22 K $\Omega$  (red-red-orange) resistor was installed instead of a 220 K $\Omega$  (red-red-yellow) resistor, the circuit would not operate properly.
6. Check for bits of solder, wire ends or other foreign matter which may be lodged in the wiring beneath the chassis.
7. If, after careful checks, the trouble is still not located and a voltmeter is available, check voltage readings against those found on the Schematic Diagram. NOTE: All voltage readings were taken with an 11 megohm input vacuum tube voltmeter. Voltages may vary  $\pm 10\%$ .
8. A review of the Circuit Description will prove helpful in indicating where to look for trouble.

NOTE: In an extreme case where you are unable to resolve a difficulty, refer to the Service and Warranty section of the "Kit Builders Guide," and to the "Factory Repair Service" information on Page 41 of this Manual.

### TROUBLESHOOTING

#### Oscillator

To determine if the oscillator stage is operating, measure the voltage at pin 2 or pin 9 of tube V1. Key-down voltage should be -18 V DC; with the key up, the voltage should be -85 V DC. Also check other voltages around tube socket V1, and check wiring of the crystal sockets and CRYSTAL switch.

#### Driver

Driver voltage can be checked at pin 2 or pin 9 of V2. Key-down voltage should be -95 V DC, key-up voltage -85 V DC. If the oscillator bias was normal, but there is no driver bias with the key down, check the 40 meter coil. Try re-peaking this coil. If there is no bias on the driver stage with the key up or down, check the 1 mh RF choke, R6, and C1. Check all voltages around V2.

#### Final Amplifier

With the driver stage tuned for 2.5 ma drive, measure key-up and key-down voltage on V3.

If no operating bias is measured, check the rear wafer of the BAND switch, the 1.1 mh RFC, R11, R12, and R30. Check all voltages on V3.



If bias is normal (about -65 volts) but there is no dip in final plate current, check the front wafer of the BAND switch, and check for shorted plates in FINAL LOADING or TUNING capacitors. Remove the low-pass filter from the circuit by disconnecting it from the final amplifier tank coil, and check for a final plate current dip. If a dip is now obtainable, check assembly of the low-pass filter for possible wiring errors or shorts.

### Audio Section

Carefully check the voltages on V4 and V5. Try a substitute microphone to further isolate

the problem. Be sure that the Audio Gain control is set properly. An audio oscillator and oscilloscope may be used for checking this stage.

### Power Supply

Voltage checks at various points in the power supply will localize the problem. If B+ voltage is low, check R35, the silicon diodes, C39, C40, and C41. If the -135 V DC bias is not present, check C37, C38, and the bias supply silicon diode D5. If the silicon diode is installed in reverse, +135 V DC would appear across C37 and C38.

## FACTORY REPAIR SERVICE

You can return your completed kit to the Heath Company Service Department to have it repaired for a minimum service fee. (Kits that have been modified will not be accepted for repair.) If you wish, you can deliver your kit to a nearby Heath Authorized Service Center. These centers are listed in your Heathkit catalog.

To be eligible for replacement parts under the terms of the warranty, equipment returned for factory repair service, or delivered to a Heath Authorized Service Center, must be accompanied by the invoice or the sales slip, or a copy of either. If you send the original invoice or sales slip, it will be returned to you.

If it is not convenient to deliver your kit to a Heath Authorized Service Center, please ship it to the factory at Benton Harbor, Michigan and follow the following shipping instructions:

Prepare a letter in duplicate, containing the following information:

- Your name and return address.
- Date of purchase.
- A brief description of the difficulty.
- The invoice or sales slip, or a copy of either.
- Your authorization to ship the repaired unit back to you C.O.D. for the service and shipping charges, plus the cost of parts not covered by the warranty.

Attach the envelope containing one copy of this letter directly to the unit before packaging, so that we do not overlook this important information. Send the second copy of the letter by separate mail to Heath Company, Attention: Service Department, Benton Harbor, Michigan.

Check the equipment to see that all parts and screws are in place. (Do not include wooden cabinets when shipping receivers, tuners, amplifiers, or TV sets, as these are easily damaged in shipment.) Then, wrap the equipment in heavy paper. Place the equipment in a strong carton, and put at least THREE INCHES of resilient packing material (shredded paper, excelsior, etc.) on all sides, between the equipment and the carton. Seal the carton with gummed paper tape, and tie it with a strong cord. Ship it by prepaid express, United Parcel Service, or insured parcel post to:

Heath Company  
Service Department  
Benton Harbor, Michigan 49022

---

To order parts, use the Parts Order Form furnished with this kit. If Parts Order Form is not available, refer to Replacement Parts in the Kit Builders Guide.

## REPLACEMENT PARTS PRICE LIST

PART No.	PRICE Each	DESCRIPTION	PART No.	PRICE Each	DESCRIPTION
<b>RESISTORS</b>			<b>Tubular and Mylar</b>		
<b>1/2 Watt</b>			23-28	.20	.1 $\mu$ fd, tubular
1-130	.15	8.2 $\Omega$	27-115	.10	.005 $\mu$ fd, Mylar
1-41	.10	10 $\Omega$	<b>Electrolytic</b>		
1-45	.10	220 $\Omega$	25-16	.80	20 $\mu$ fd, 350 V
1-79	.10	820 $\Omega$	25-36	1.00	40 $\mu$ fd, 450 V
1-90	.10	2000 $\Omega$	25-80	1.00	20-20 $\mu$ fd, 150 V
1-14	.10	3300 $\Omega$	25-37	1.70	40-40 $\mu$ fd, 450 V
1-16	.10	4700 $\Omega$	<b>Variable</b>		
1-69	.10	18 K $\Omega$	26-64	1.40	1-section
1-22	.10	22 K $\Omega$	26-102	2.45	2-section
1-24	.10	33 K $\Omega$	26-101	5.00	3-section
1-25	.10	47 K $\Omega$	<b>CONTROLS-SWITCHES</b>		
1-33	.10	470 K $\Omega$	11-20	2.25	25 K $\Omega$ control
1-35	.10	1 megohm	10-58	.35	100 K $\Omega$ twist-tab control
1-37	.10	2.2 megohm	60-15	.30	DPDT slide switch
1-70	.10	22 megohm	63-290	2.00	1-wafer rotary switch
<b>1 Watt</b>			63-246	2.05	Ceramic rotary switch
1-2-1	.10	1000 $\Omega$	63-244	2.85	2-wafer rotary switch
1-24-1	.10	4700 $\Omega$	<b>TRANSFORMER-COILS-CHOKES</b>		
<b>2 Watt</b>			54-179-24	19.70	Power transformer
1-30-2	.20	270 $\Omega$	40-644	2.65	Final amplifier coil
1-15-2	.20	1000 $\Omega$	141-14	3.85	Coil and choke package
1-17-2	.20	6800 $\Omega$	Consisting of:		
1-3-2	.20	10 K $\Omega$	40-79	.45	40 meter oscillator coil
1-4-2	.20	15 K $\Omega$	40-337	1.30	Driver plate coil
1-18-2	.20	33 K $\Omega$	40-347	.20	.32 $\mu$ h low-pass filter coil
1-10-2	.20	47 K $\Omega$	40-348	.20	.44 $\mu$ h low-pass filter coil
1-24-2	.20	100 K $\Omega$	40-349	.20	.5 $\mu$ h low-pass filter coil
<b>7 Watt</b>			45-3	.30	1 mh RF choke
3-9-7	.15	100 $\Omega$ wire-wound	45-4	.40	1.1 mh RF choke
<b>CAPACITORS</b>			45-19	.40	Parasitic choke
<b>Silver Mica</b>			45-41	.95	.425 mh RF choke
20-101	.15	47 $\mu$ mf	<b>TUBES-LAMPS-DIODES</b>		
20-102	.15	100 $\mu$ mf	411-63	1.90	6CL6 tube
20-105	.20	180 $\mu$ mf	411-109	1.85	6DE7 tube
<b>Molded Mica</b>			411-75	4.35	6146 tube
20-64	.15	120 $\mu$ mf	411-26	1.20	12AX7 tube
20-48	.85	.001 $\mu$ fd, 2 KV	57-27	.60	Silicon diode
<b>Disc</b>			412-36	.20	NE-2E neon lamp
21-49	.20	68 $\mu$ mf, 4 KV	413-10	.10	Red lens
21-9	.10	100 $\mu$ mf	413-11	.10	Clear lens
21-14	.10	.001 $\mu$ fd	<b>TERMINAL STRIPS-SOCKETS-PHONE JACK</b>		
21-71	.15	.001 $\mu$ fd 1.4 KV	431-14	.10	2-lug terminal strip (one lug ground)
21-57	.10	.005 $\mu$ fd	431-1	.10	2-lug upright terminal strip
21-72	.20	.005 $\mu$ fd, 1.4 KV	431-10	.10	3-lug terminal strip
			431-12	.10	4-lug terminal strip
			431-40	.10	4-lug terminal strip



PART No.	PRICE Each	DESCRIPTION	PART No.	PRICE Each	DESCRIPTION
<b>Terminal Strips-Sockets-Phone Jack (cont'd.)</b>			<b>Hardware (cont'd.)</b>		
431-55	.10	6-lug terminal strip	254-3	.05	#10 lockwasher
431-45	.10	6-lug terminal strip	254-5	.05	Thin control lockwasher
431-41	.10	2-lug high voltage terminal strip	254-4	.05	Control lockwasher
431-43	.10	3-lug high voltage terminal strip	253-9	.05	#8 flat washer
431-42	.10	5-lug high voltage terminal strip	253-10	.05	Control flat washer
434-36	.30	9-pin ceramic tube socket	253-19	.05	#10 flat washer
434-43	.20	9-pin molded tube socket	259-6	.05	#6 small solder lug
434-39	.15	Octal tube socket	259-1	.05	#6 solder lug
434-38	.20	Crystal socket	259-10	.05	Control solder lug
434-74	.15	Crystal socket	455-9	.15	3/8" bushing
434-42	.10	Phono socket	456-7	.25	1/4" shaft coupler
436-4	.35	Phone jack	<b>METAL PARTS</b>		
432-3	.25	Microphone connector	90-358	2.80	Cabinet
438-4	.10	Phono plug	200-425-1	3.25	Chassis
<b>WIRE-SLEEVEING</b>			203-485	1.10	Front panel
89-1	.35	Line cord	205-259	.35	Top plate
344-54	.05/ft	Yellow hookup wire	205-260	.90	Bottom plate
344-52	.05/ft	Red hookup wire	206-271	.45	Front shield
344-50	.05/ft	Black hookup wire	206-272	.80	Rear shield
344-51	.05/ft	Brown hookup wire	206-136	.30	Oscillator shield
344-6	.05/ft	Large red hookup wire	206-137	.50	Driver shield
340-2	.05/ft	Small bare wire	206-273	.25	Center shield
340-3	.05/ft	Large bare wire	206-274	.45	Low-pass filter chassis
346-1	.05/ft	Sleeving	<b>MISCELLANEOUS</b>		
134-25	2.05	Wire harness	453-66	.10	5" shaft
<b>HARDWARE</b>			453-102	.15	7-7/8" shaft
250-49	.05	3-48 x 1/4" screw	462-122	.20	Skirt knob
250-34	.05	4-40 x 1/2" screw	100-687	.70	Knob with pointer assembly
250-7	.05	6-32 x 3/16" round head screw	73-4	.10	5/16" grommet
250-56	.05	6-32 x 1/4" screw	73-1	.10	3/8" grommet
250-116	.05	6-32 x 1/4" black screw	261-9	.05	Rubber foot
250-89	.05	6-32 x 3/8" screw	260-39	.05	Anode clip (appearance may vary)
250-8	.05	#6 sheet metal screw	206-3	.20	2" tube shield
250-152	.05	10-24 x 3/4" screw	206-54	.30	2-3/8" tube shield
251-1	.05	6-32 spade bolt	65-9	.45	Circuit breaker
252-1	.05	3-48 nut	75-24	.10	Line cord strain relief
252-15	.05	4-40 nut	481-1	.10	Capacitor mounting wafer
252-3	.05	6-32 nut	*407-76	7.90	Meter
252-4	.05	8-32 nut	331-6	.15	Solder
252-30	.05	10-24 nut		2.00	Manual (See front cover for part number.)
252-31	.10	10-24 wing nut	The above prices apply only on purchases from the Heath Company where shipment is to a U.S.A. destination. Add 10% (minimum 25 cents) to the price when ordering from an authorized Service Center or Heathkit Electronic Center to cover local sales tax, postage and handling. Outside the U.S.A. parts and service are available from your local Heathkit source and will reflect additional transportation, taxes, duties and rates of exchange.		
252-7	.05	Control nut			
252-22	.05	6-32 speednut			
252-32	.05	Push-on speednut			
254-7	.05	#3 lockwasher			
254-1	.05	#6 lockwasher			
254-2	.05	#8 lockwasher			









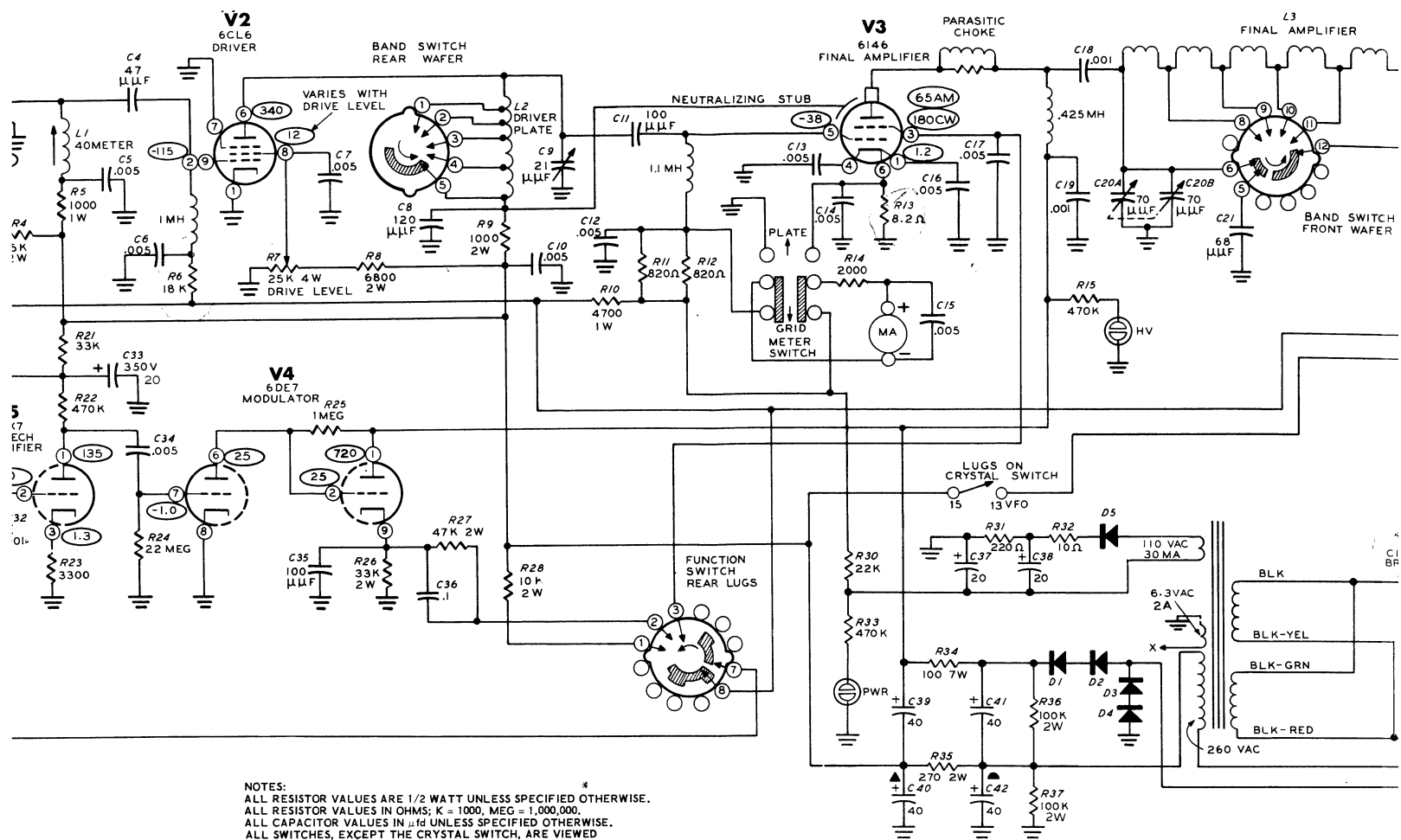

NOTES:  
 ALL RESISTOR VALUES ARE 1/2 WATT UNLESS SPECIFIED OTHERWISE.  
 ALL RESISTOR VALUES IN OHMS; K = 1000, MEG = 1,000,000.  
 ALL CAPACITOR VALUES IN  $\mu$ F UNLESS SPECIFIED OTHERWISE.  
 ALL SWITCHES, EXCEPT THE CRYSTAL SWITCH, ARE VIEWED FROM THE REAR. THE CRYSTAL SWITCH IS VIEWED FROM THE SHAFT END.  
 FUNCTION SWITCH SHOWN IN OFF POSITION.  
 BAND SWITCH SHOWN IN 80 METER POSITION.  
 ○ INDICATES VOLTAGE READINGS.  
 VOLTAGES TAKEN WITH FUNCTION SWITCH IN AM POSITION.  
 VOLTAGES TAKEN WITH AN 11 MEGOHM INPUT METER.  
 VOLTAGE READINGS ARE DC UNLESS SPECIFIED OTHERWISE.  
 VOLTAGES MAY VARY  $\pm 10\%$ .  
 VOLTAGES TAKEN WITH DUMMY LOAD CONNECTED.

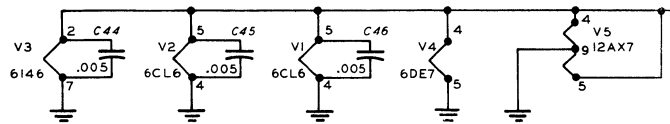

ATHKIT®  
 FILTER

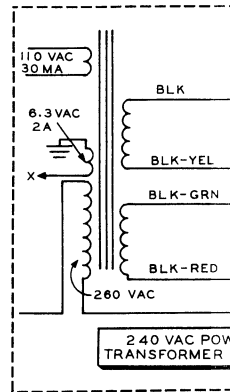
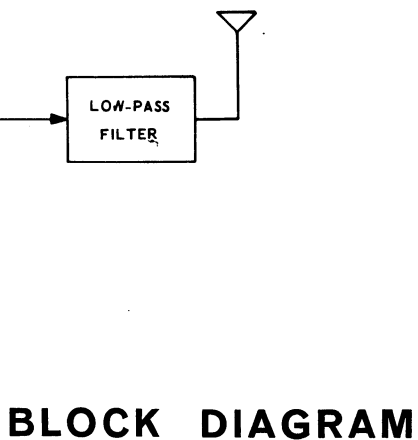



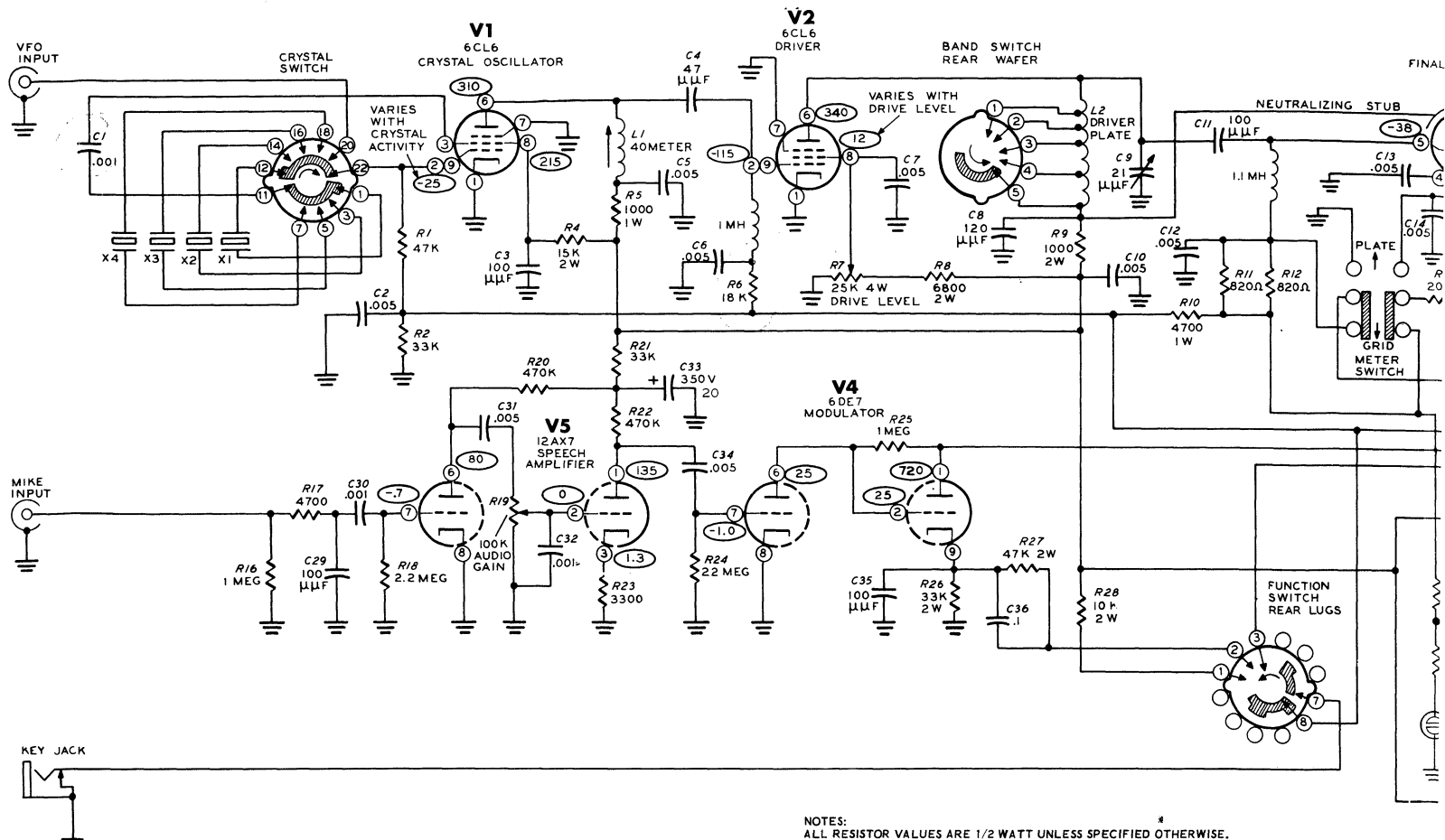

**Schematic of the HEATHKIT®  
AMATEUR TRANSMITTER  
Model DX - 60B**

NOTES:  
 ALL RESISTOR VALUES ARE 1/2 WATT UNLESS SPECIFIED OTHERWISE.  
 ALL RESISTOR VALUES IN OHMS; K = 1000, MEG = 1,000,000.  
 ALL CAPACITOR VALUES IN  $\mu$ fd UNLESS SPECIFIED OTHERWISE.  
 ALL SWITCHES, EXCEPT THE CRYSTAL SWITCH, ARE VIEWED FROM THE REAR. THE CRYSTAL SWITCH IS VIEWED FROM THE SHAFT END.  
 FUNCTION SWITCH SHOWN IN OFF POSITION.  
 BAND SWITCH SHOWN IN 80 METER POSITION.  
 ○ INDICATES VOLTAGE READINGS.  
 VOLTAGES TAKEN WITH FUNCTION SWITCH IN AM POSITION.  
 VOLTAGES TAKEN WITH AN 11 MEGOHM INPUT METER.  
 VOLTAGE READINGS ARE DC UNLESS SPECIFIED OTHERWISE.  
 VOLTAGES MAY VARY  $\pm 10\%$ .  
 VOLTAGES TAKEN WITH DUMMY LOAD CONNECTED.

V3  
6146

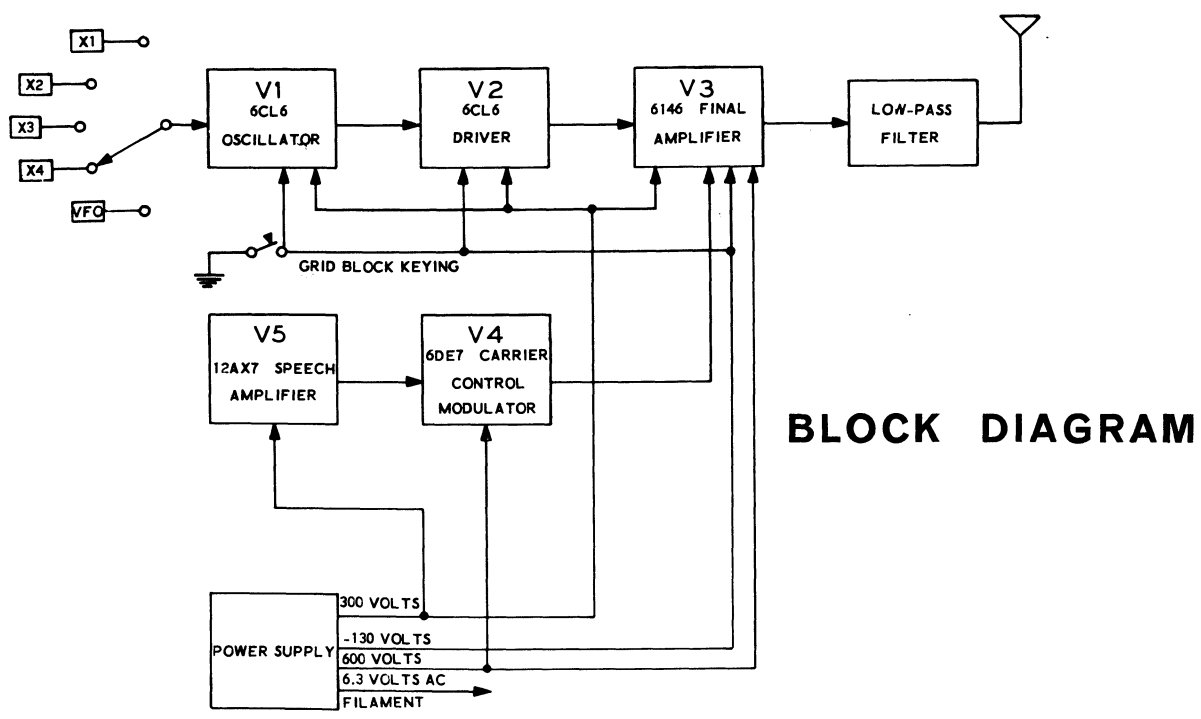

**BLOCK DIAGRAM**



# PARTS PICTORIAL

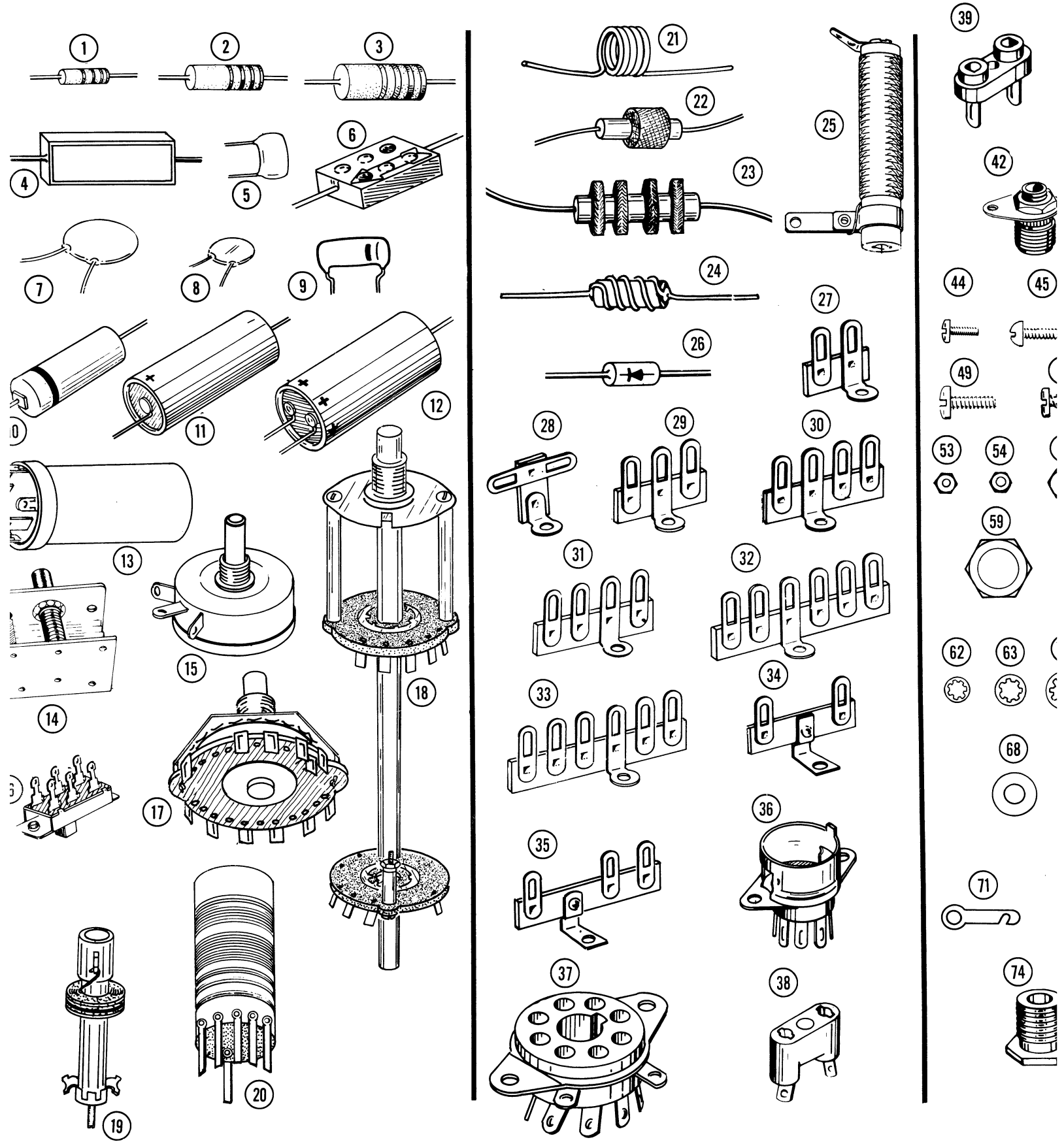

# PARTS PICTORIAL

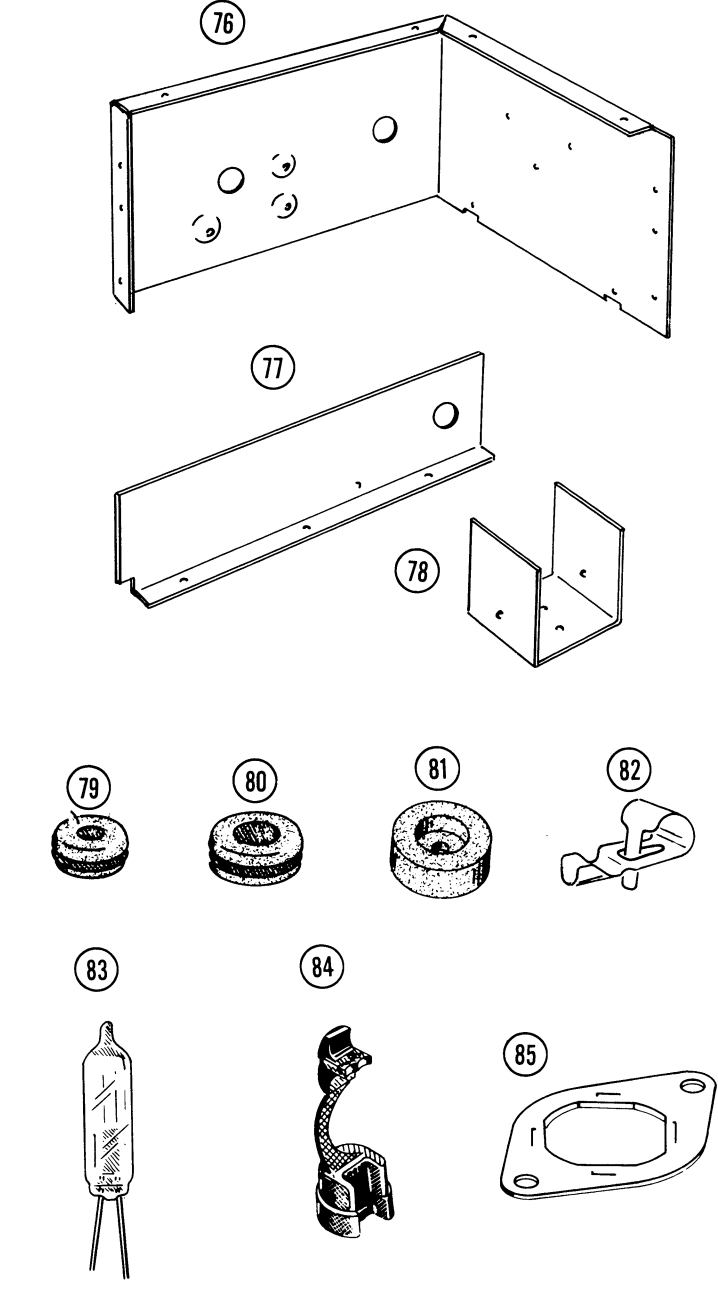
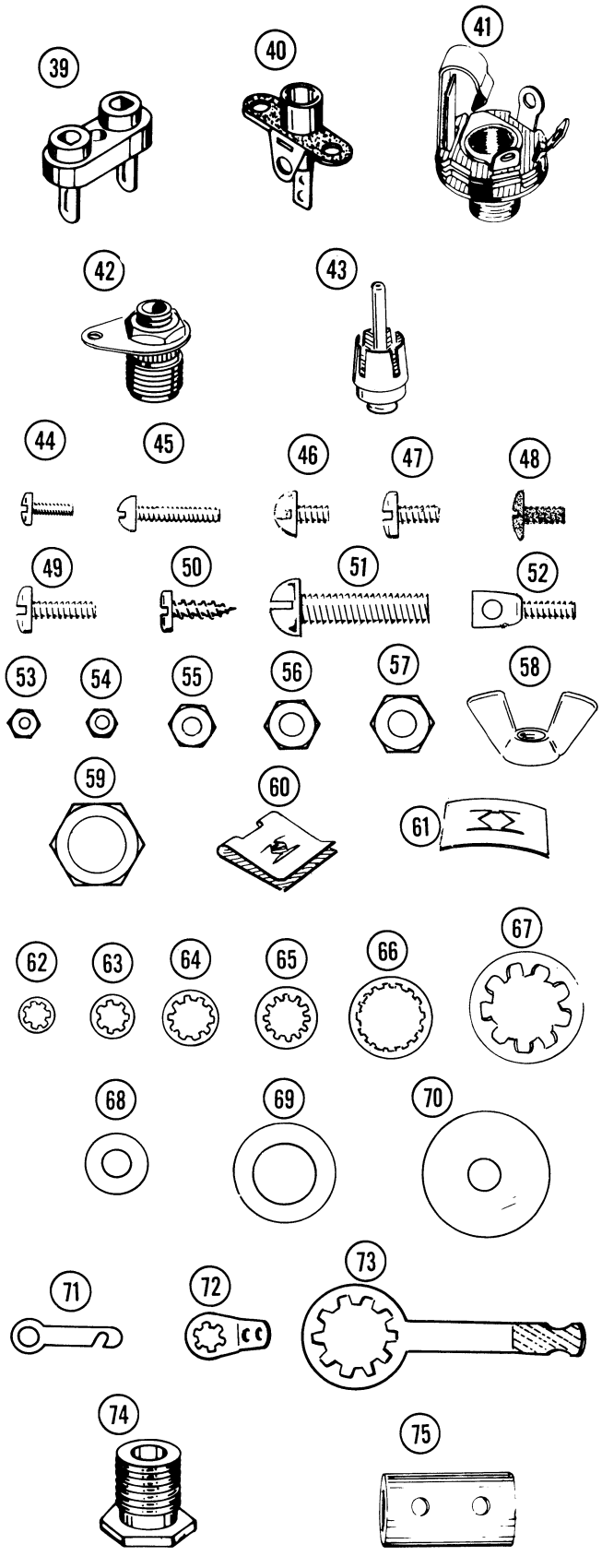
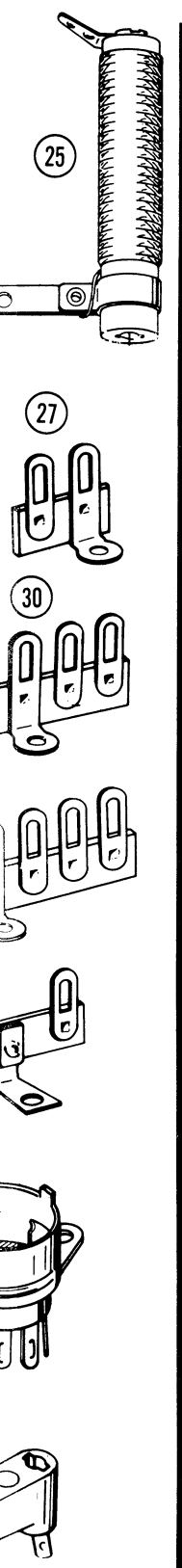

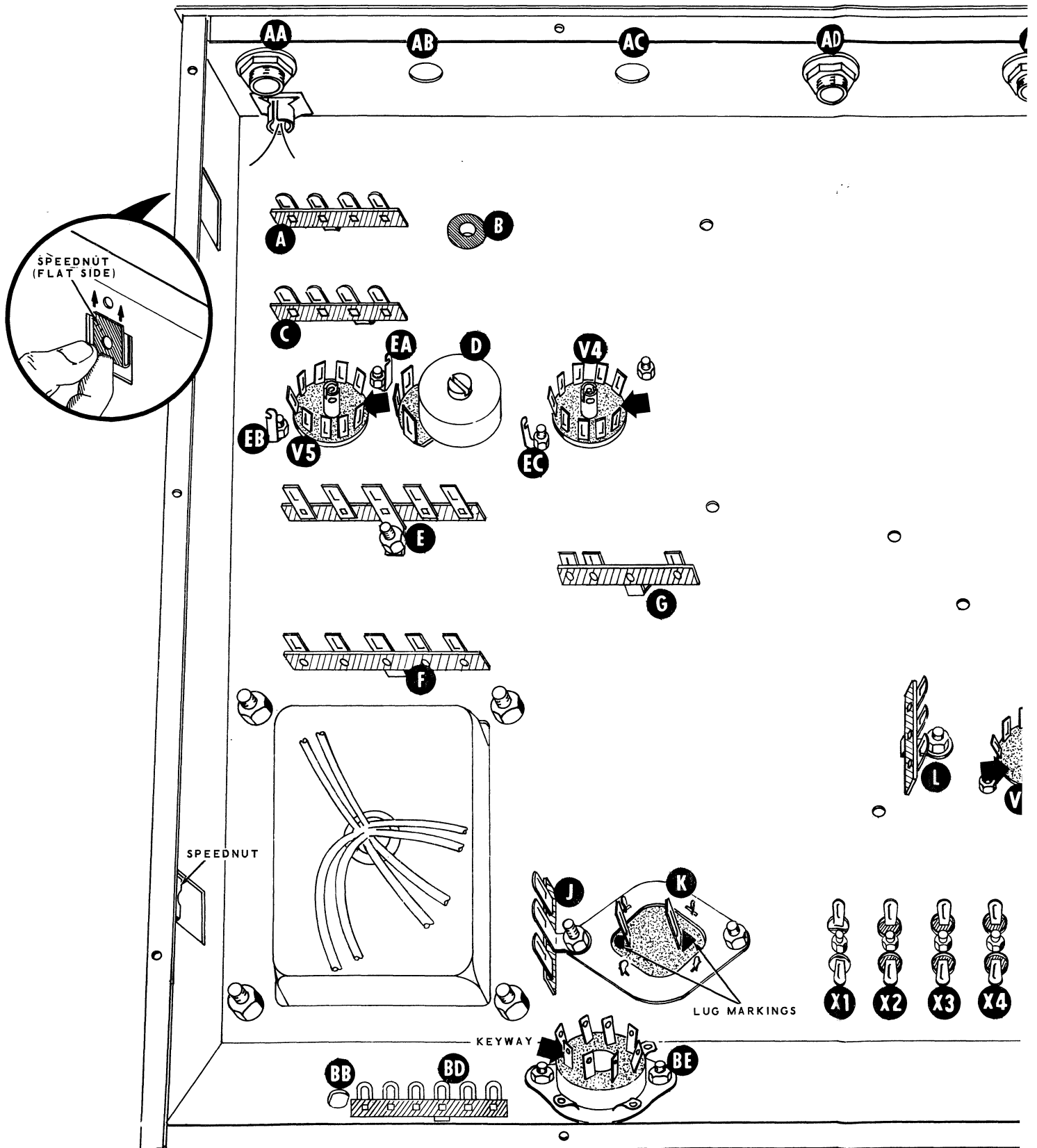

**PICTORIAL 1**

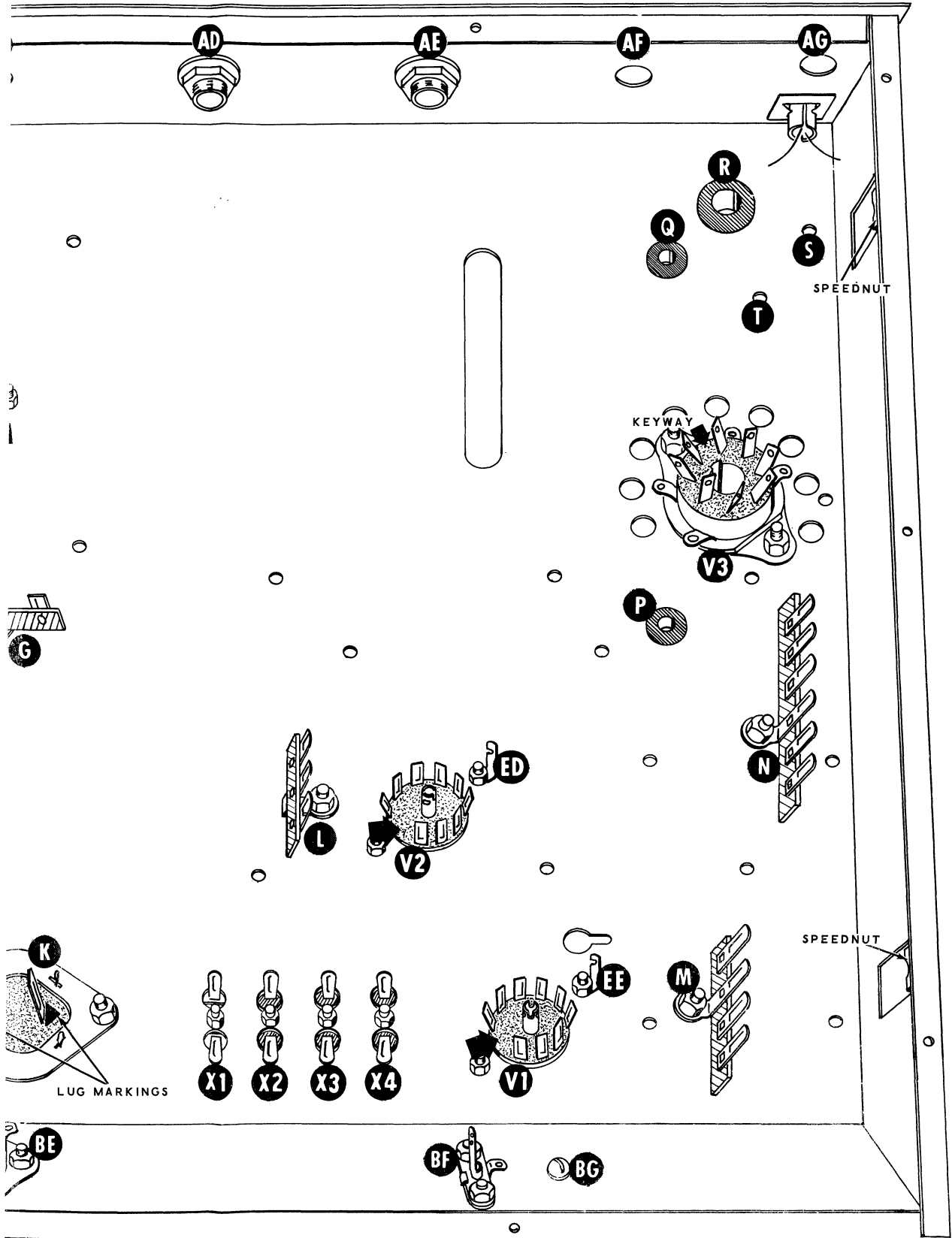

**PICTORIAL 1**



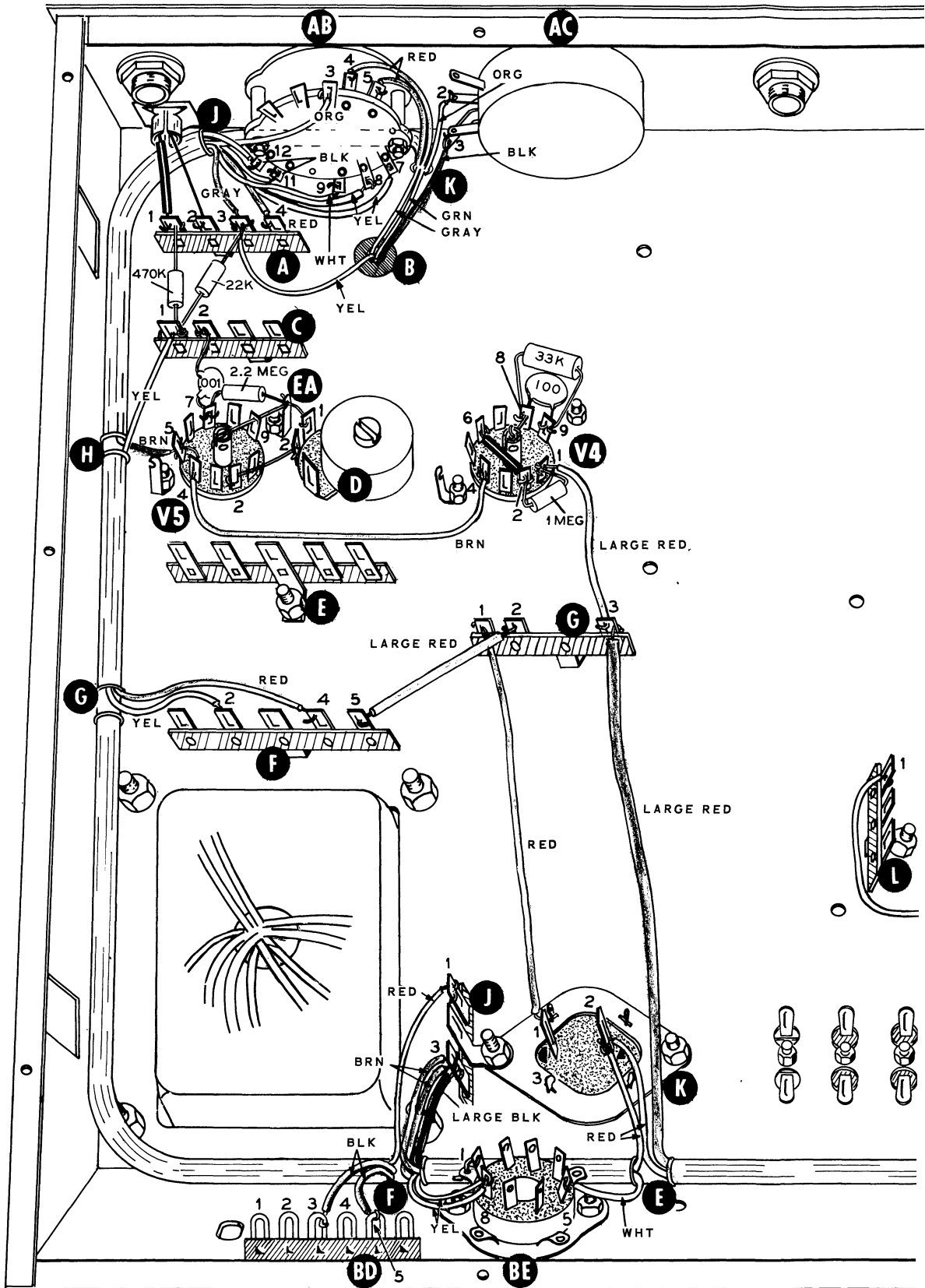

**PICTORIAL 2**

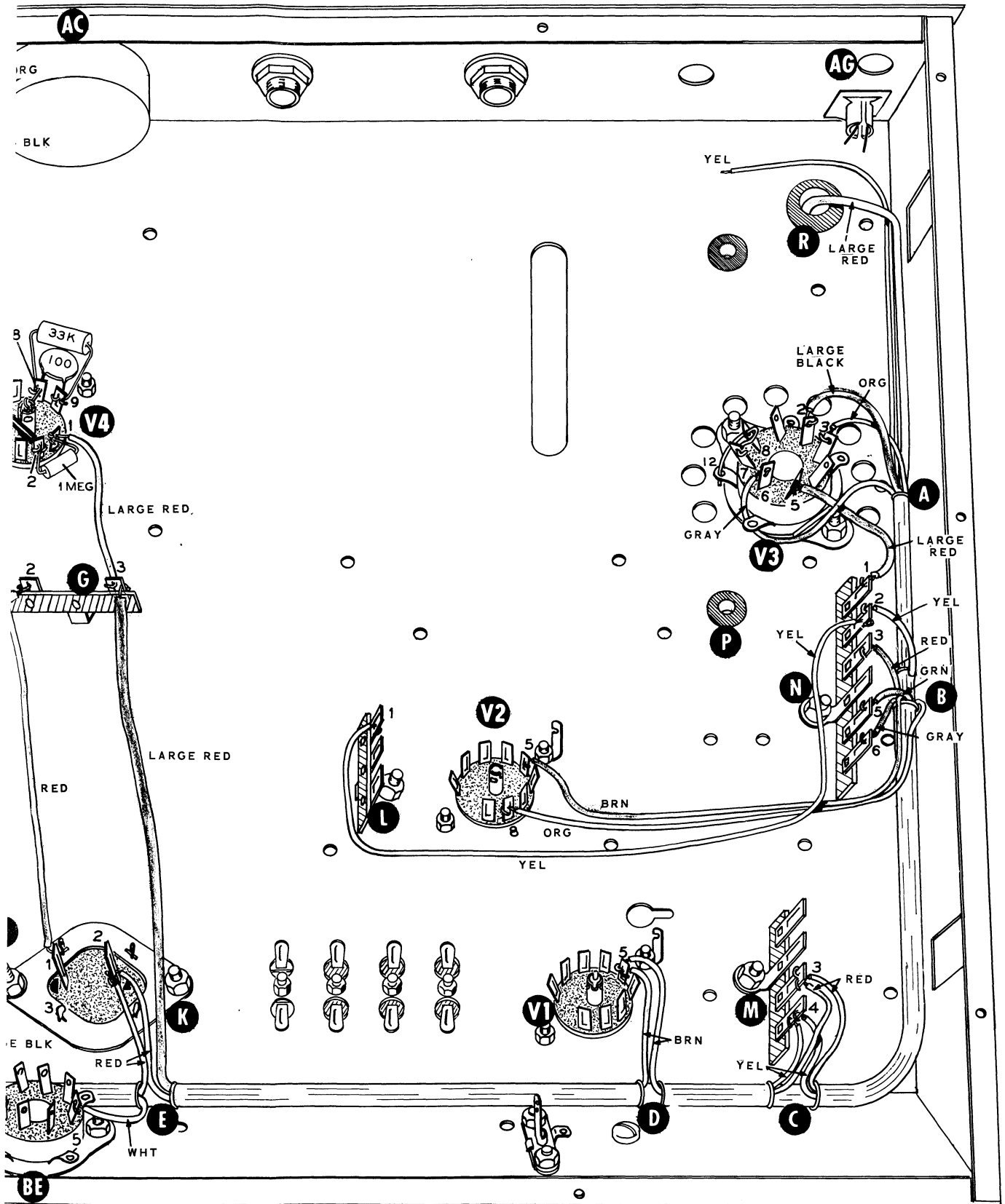

**PICTORIAL 2**

# 240 VAC WIRING

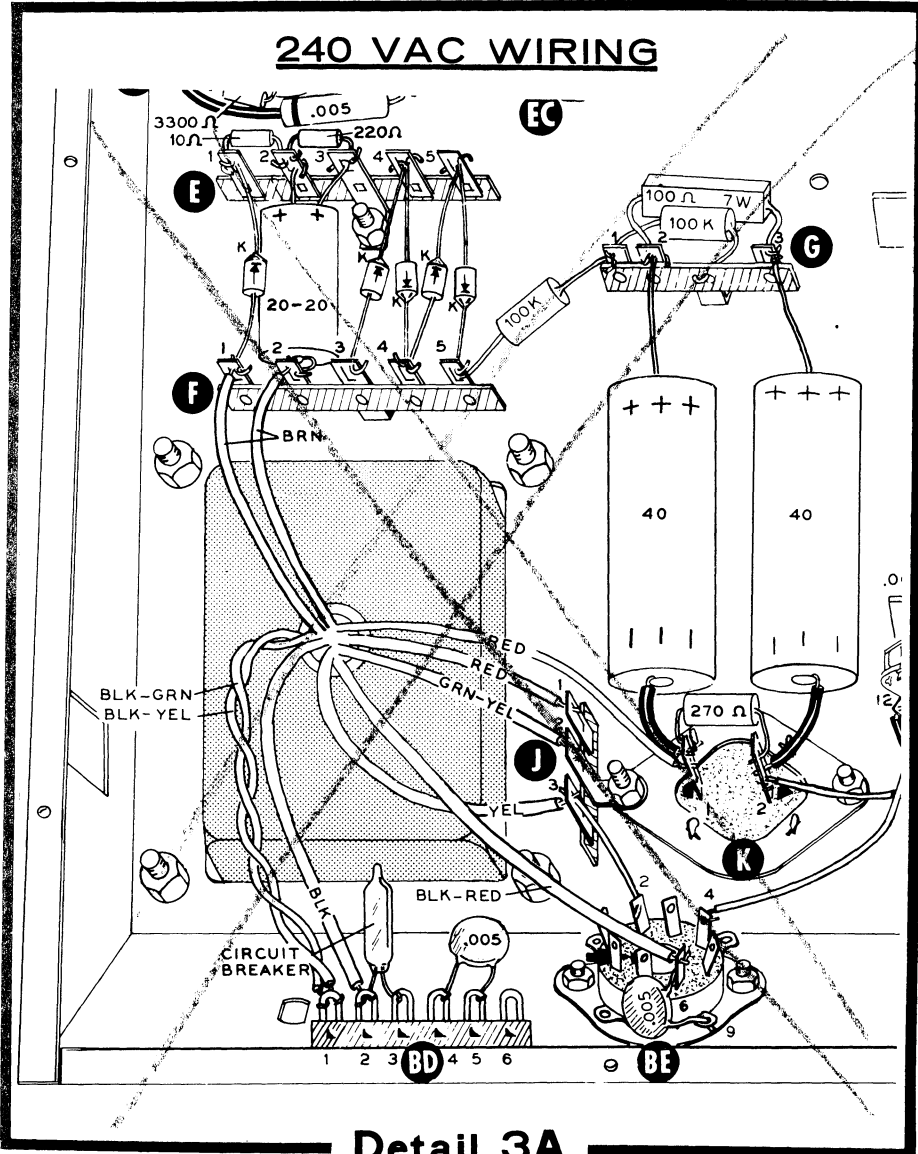

**Detail 3A**

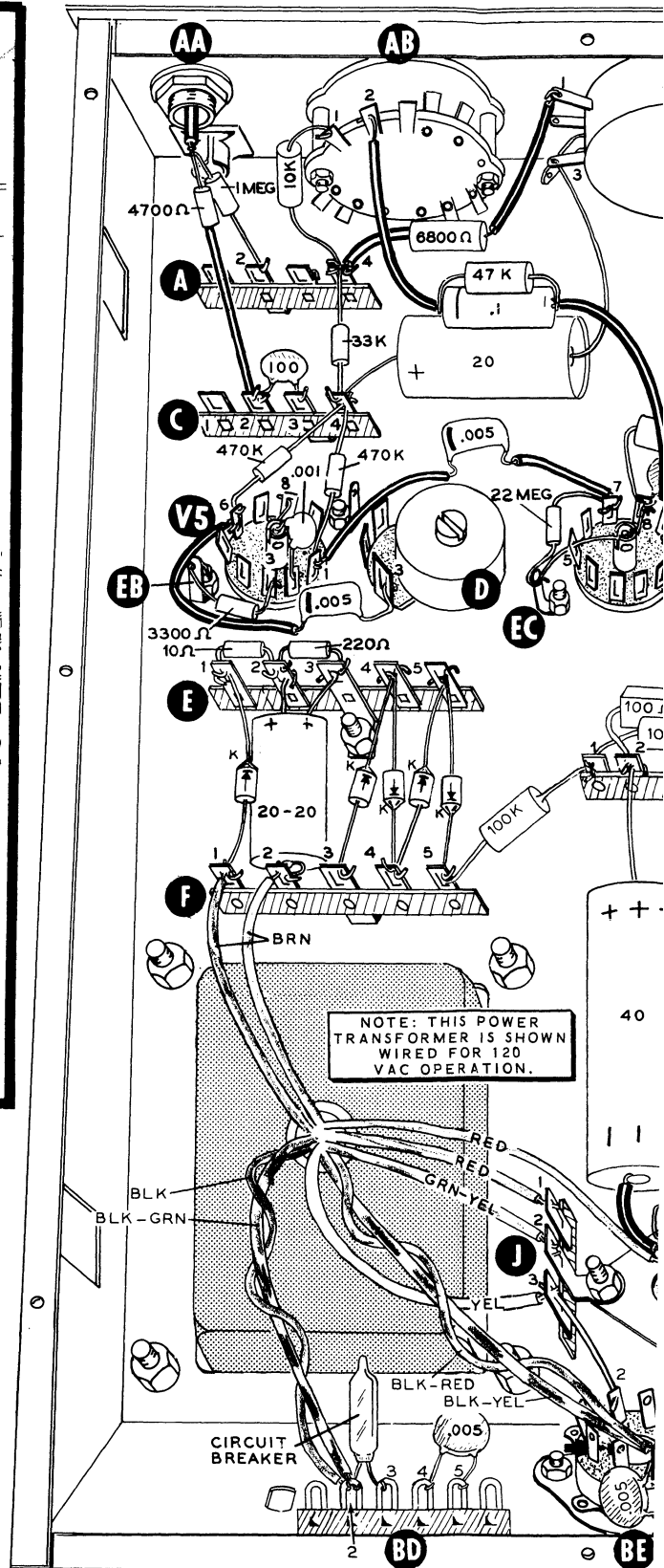



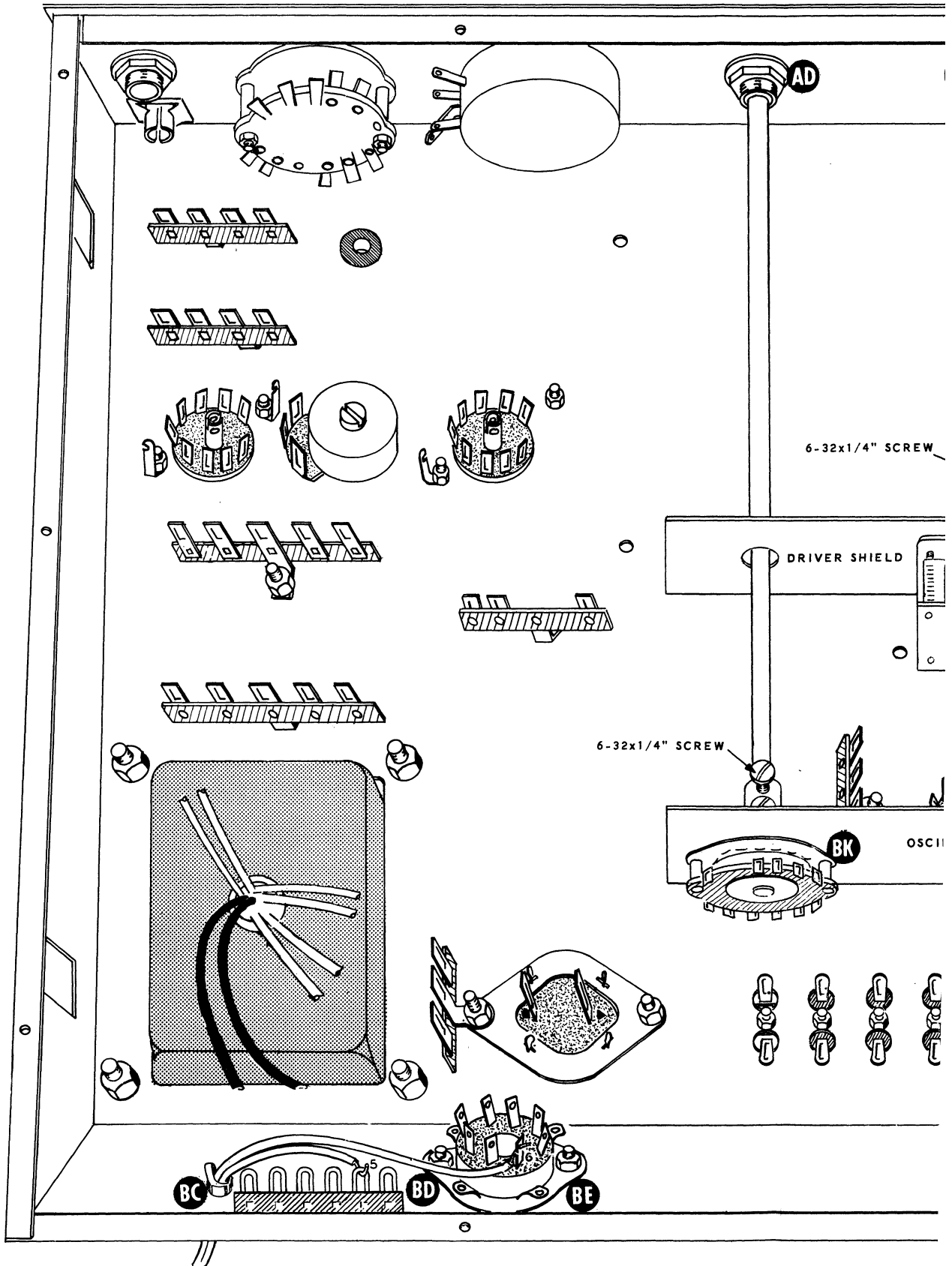

PICTORIAL 13

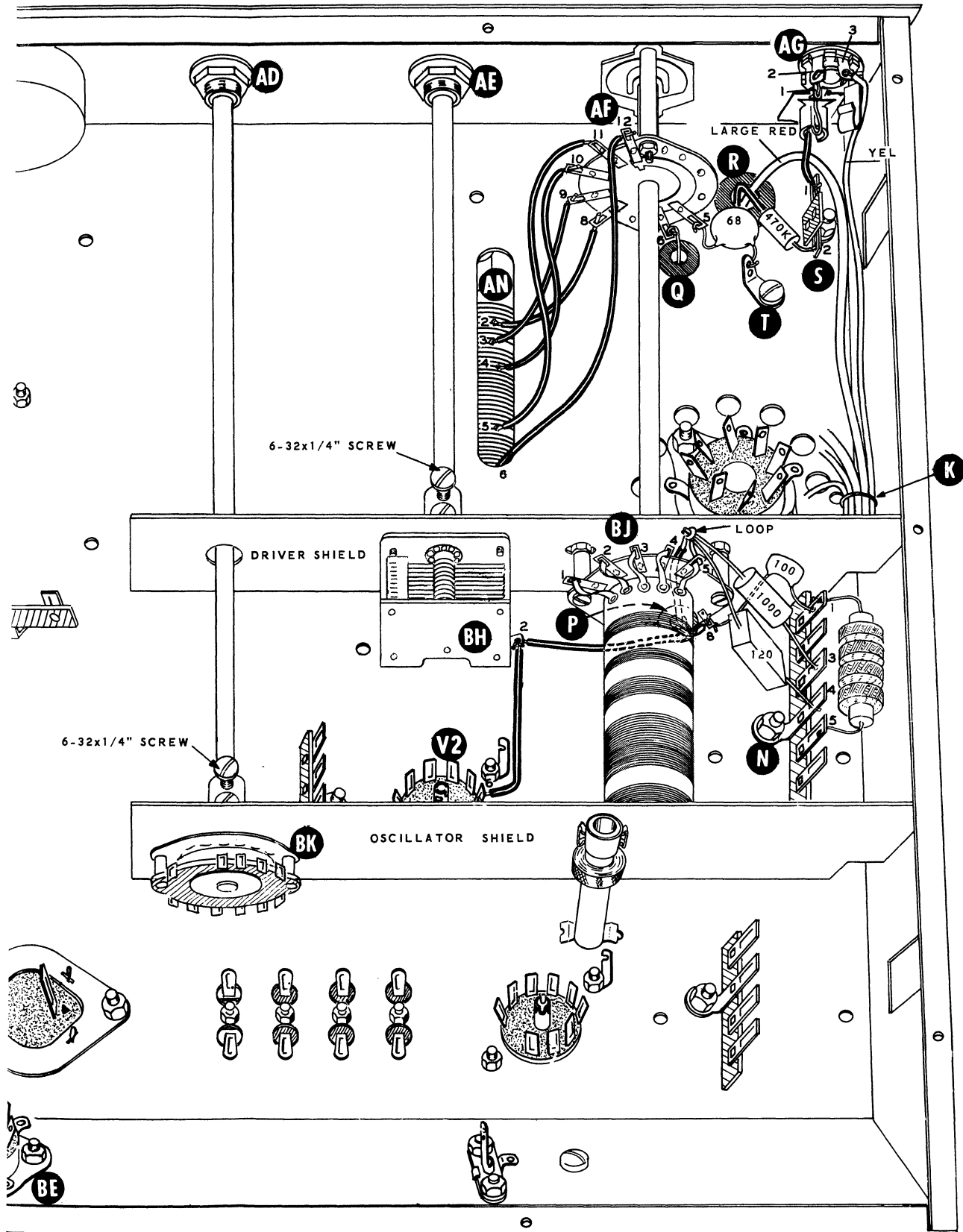









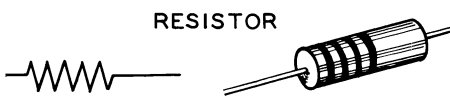
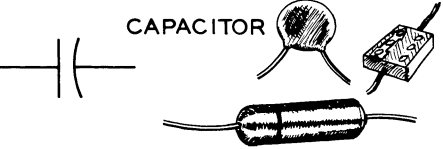
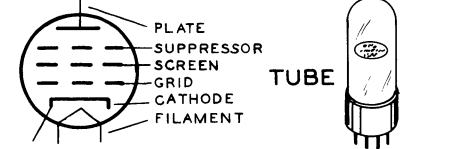
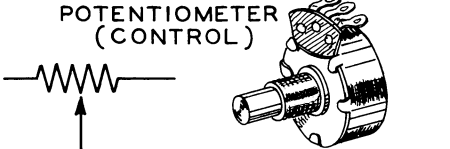
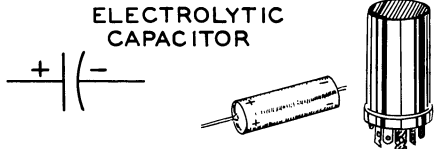
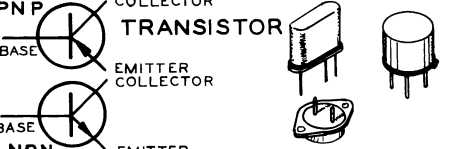
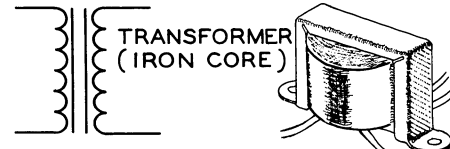
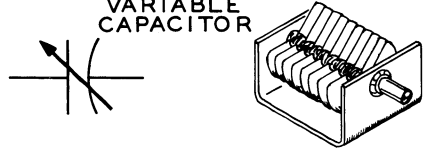
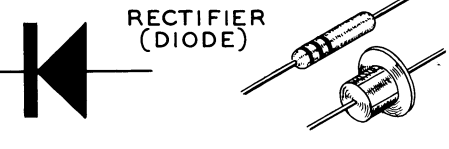
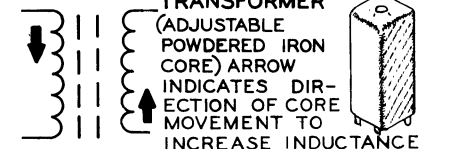
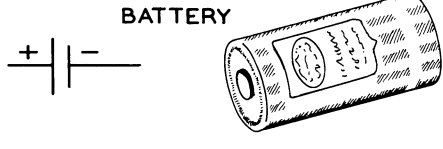
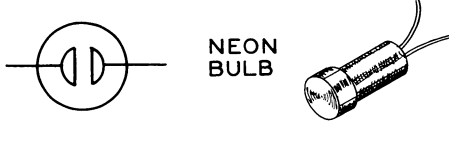
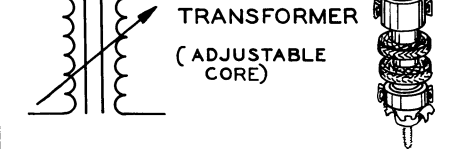

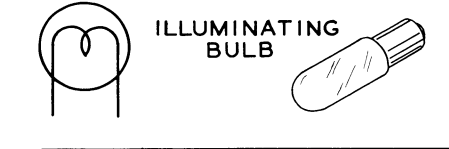
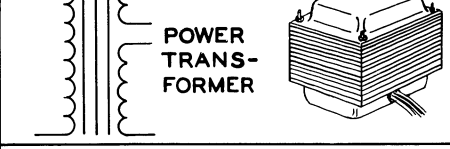
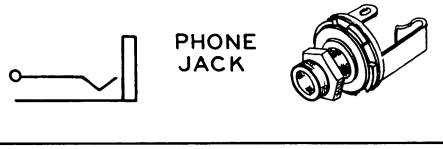
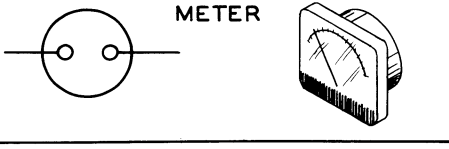
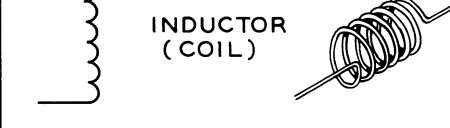

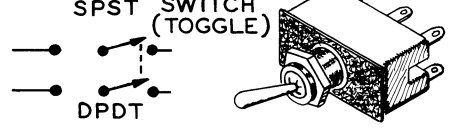
PICTORIAL 13

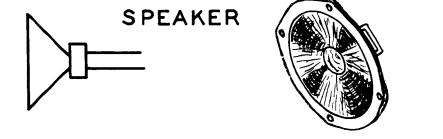
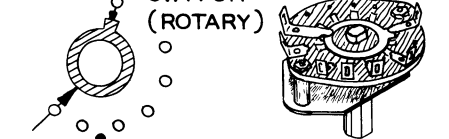
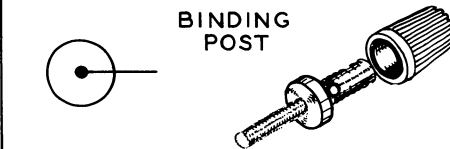
## TYPICAL COMPONENT TYPES

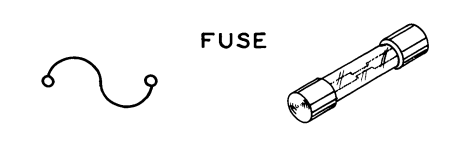
This chart is a guide to commonly used types of electronic components. The symbols and related illustrations

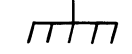
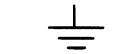
should prove helpful in identifying most parts and reading the schematic diagrams.

<p style="text-align: center;"><b>RESISTOR</b></p> 	<p style="text-align: center;"><b>CAPACITOR</b></p> 	<p style="text-align: center;"><b>TUBE</b></p> 
<p style="text-align: center;"><b>POTENTIOMETER (CONTROL)</b></p> 	<p style="text-align: center;"><b>ELECTROLYTIC CAPACITOR</b></p> 	<p style="text-align: center;"><b>TRANSISTOR</b></p> 
<p style="text-align: center;"><b>TRANSFORMER (IRON CORE)</b></p> 	<p style="text-align: center;"><b>VARIABLE CAPACITOR</b></p> 	<p style="text-align: center;"><b>RECTIFIER (DIODE)</b></p> 
<p style="text-align: center;"><b>TRANSFORMER (ADJUSTABLE POWDERED IRON CORE) ARROW INDICATES DIRECTION OF CORE MOVEMENT TO INCREASE INDUCTANCE</b></p> 	<p style="text-align: center;"><b>BATTERY</b></p> 	<p style="text-align: center;"><b>NEON BULB</b></p> 
<p style="text-align: center;"><b>TRANSFORMER (ADJUSTABLE CORE)</b></p> 	<p style="text-align: center;"><b>PHONO JACK</b></p> 	<p style="text-align: center;"><b>ILLUMINATING BULB</b></p> 
<p style="text-align: center;"><b>POWER TRANSFORMER</b></p> 	<p style="text-align: center;"><b>PHONE JACK</b></p> 	<p style="text-align: center;"><b>METER</b></p> 
<p style="text-align: center;"><b>INDUCTOR (COIL)</b></p> 	<p style="text-align: center;"><b>RECEPTACLE</b></p> 	<p style="text-align: center;"><b>SWITCH (TOGGLE)</b></p> 
<p style="text-align: center;"><b>PIEZOELECTRIC CRYSTAL</b></p> 	<p style="text-align: center;"><b>SPEAKER</b></p> 	<p style="text-align: center;"><b>SWITCH (ROTARY)</b></p> 
<p style="text-align: center;"><b>BINDING POST</b></p> 	<p style="text-align: center;"><b>MICROPHONE</b></p> 	<p style="text-align: center;"><b>FUSE</b></p> 
<p style="text-align: center;"><b>ANTENNA</b></p>  <p style="text-align: center;">GENERAL      LOOP</p>	<p style="text-align: center;"><b>EARTH GROUND</b></p>  <p style="text-align: center;"><b>CHASSIS GROUND</b></p> 	<p style="text-align: center;"><b>CONDUCTORS</b></p>  <p style="text-align: center;">NOT CONNECTED      CONNECTED      SHIELDED</p>

# HEATH COMPANY

PENNSYLVANIA HARBOR WISCONSIN

**THE WORLD'S FINEST ELECTRONIC EQUIPMENT IN KIT FORM**

LITHO IN U.S.A.