

HEATHKIT[®] MANUAL

for the

HF SSB TRANSCEIVER Model HW-5400

ASSEMBLY

595-2891-02

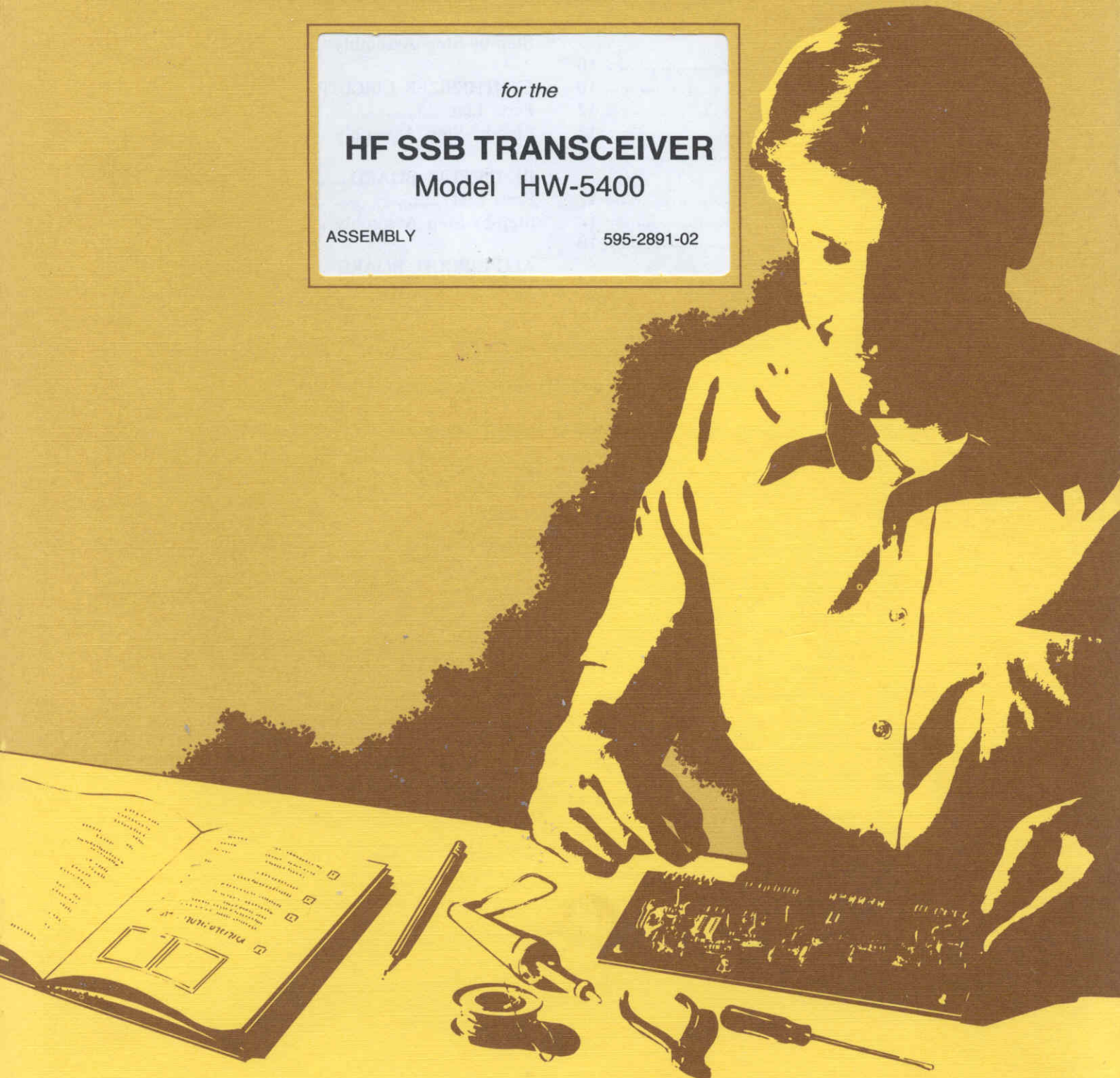

HEATH COMPANY • BENTON HARBOR, MICHIGAN

HEATH COMPANY PHONE DIRECTORY

The following telephone numbers are direct lines to the departments listed:

Kit orders and delivery information (616) 982-3411
Credit (616) 982-3561
Replacement Parts (616) 982-3571

Technical Assistance Phone Numbers

8:00 A.M. to 12 P.M. and 1:00 P.M. to 4:30 P.M., EST, Weekdays Only
R/C, Audio, and Electronic Organs (616) 982-3310
Amateur Radio (616) 982-3296
Test Equipment, Weather Instruments and
Home Clocks (616) 982-3315
Television (616) 982-3307
Aircraft, Marine, Security, Scanners, Automotive,
Appliances and General Products (616) 982-3496
Computers — Hardware (616) 982-3309
Computers — Software:
Operating Systems, Languages, Utilities (616) 982-3860
Application Programs (616) 982-3884
Heath Craft Wood Works (616) 982-3423



YOUR HEATHKIT 90-DAY LIMITED WARRANTY

Consumer Protection Plan for Heathkit Consumer Products

Welcome to the Heath family. We believe you will enjoy assembling your kit and will be pleased with its performance. Please read this Consumer Protection Plan carefully. It is a "LIMITED WARRANTY" as defined in the U.S. Consumer Product Warranty and Federal Trade Commission Improvement Act. This warranty gives you specific legal rights, and you may also have other rights which vary from state to state.

Heath's Responsibility

PARTS — Replacements for factory defective parts will be supplied free for 90 days from date of purchase. Replacement parts are warranted for the remaining portion of the original warranty period. You can obtain warranty parts direct from Heath Company by writing or telephoning us at (616) 982-3571. And we will pay shipping charges to get those parts to you . . . anywhere in the world.

SERVICE LABOR — For a period of 90 days from the date of purchase, any malfunction caused by defective parts or error in design will be corrected at no charge to you. You must deliver the unit at your expense to the Heath factory, any Heathkit Electronic Center (units of Veritechnology Electronics Corporation), or any of our authorized overseas distributors.

TECHNICAL CONSULTATION — You will receive free consultation on any problem you might encounter in the assembly or use of your Heathkit product. Just drop us a line or give us a call. Sorry, we cannot accept collect calls.

NOT COVERED — The correction of assembly errors, adjustments, calibration, and damage due to misuse, abuse, or negligence are not covered by the warranty. Use of corrosive solder and/or the unauthorized modification of the product or of any furnished component, will void this warranty in its entirety. This warranty does not include reimbursement for inconvenience, loss of use, customer assembly, set-up time, or unauthorized service.

This warranty covers only Heath products and is not extended to other equipment or components that a customer uses in conjunction with our products.

SUCH REPAIR AND REPLACEMENT SHALL BE THE SOLE REMEDY OF THE CUSTOMER AND THERE SHALL BE NO LIABILITY ON THE PART OF HEATH FOR ANY SPECIAL, INDIRECT, INCIDENTAL OR CONSEQUENTIAL DAMAGES, INCLUDING BUT NOT LIMITED TO ANY LOSS OF BUSINESS OR PROFITS, WHETHER OR NOT FORSEEABLE.

Some states do not allow the exclusion or limitation of incidental or consequential damages, so the above limitation or exclusion may not apply to you.

Owner's Responsibility

EFFECTIVE WARRANTY DATE — Warranty begins on the date of first consumer purchase. You must supply a copy of your proof of purchase when you request warranty service or parts.

ASSEMBLY — Before seeking warranty service, you should complete the assembly by carefully following the manual instructions. Heathkit service agencies cannot complete assembly and adjustments that are customer's responsibility.

ACCESSORY EQUIPMENT — Performance malfunctions involving other non-Heath accessory equipment, (antennas, audio components, computer peripherals and software, etc.) are not covered by this warranty and are the owner's responsibility.

SHIPPING UNITS — Follow the packing instructions published in the assembly manuals. Damage due to inadequate packing cannot be repaired under warranty.

If you are not satisfied with our service (warranty or otherwise) or our products, write directly to our Director of Customer Service, Heath Company, Benton Harbor MI 49022. He will make certain your problems receive immediate, personal attention.

Heathkit® Manual

for the

HF SSB TRANSCEIVER **Model HW-5400**

ASSEMBLY

595-2891-02

HEATH COMPANY
BENTON HARBOR, MICHIGAN 49022

Copyright © 1983
Heath Company
All Rights Reserved
Printed in the United States of America

TABLE OF CONTENTS

INTRODUCTION	3	BFO CIRCUIT BOARD	104
UNPACKING INSTRUCTIONS	5	Parts List	104
ASSEMBLY NOTES	6	Step-by-Step Assembly	106
SHAFT ENCODER & RF PROBE CIRCUIT BOARDS	10	CONTROLLER CIRCUIT BOARD	114
Parts List	10	Parts List	114
Step-by-Step Assembly	12	Step-by-Step Assembly	117
Shaft Encoder Circuit Board	12	SYNTHESIZER CIRCUIT BOARD	130
RF Probe Circuit Board	15	Parts List	130
FILTER CIRCUIT BOARD	17	Step-by-Step Assembly	133
Parts List	17	RF CIRCUIT BOARD	144
Step-by-Step Assembly	19	Parts List	144
DISPLAY CIRCUIT BOARD	29	Step-by-Step Assembly	147
Parts List	29	ALC CIRCUIT BOARD	161
Step-by-Step Assembly	31	Parts List	161
AUDIO CIRCUIT BOARD	44	Step-by-Step Assembly	162
Parts List	44	PA (Power Amplifier) ASSEMBLY	166
Step-by-Step Assembly	47	Parts List	166
HIGH VCO ASSEMBLY	64	Step-by-Step Assembly	168
Parts List	64	CHASSIS	183
Step-by-Step Assembly	66	Parts List	183
LOW VCO ASSEMBLY	74	Step-by-Step Assembly	186
Parts List	74	Audio Circuit Board Installation	224
Step-by-Step Assembly	76	BFO Circuit Board Installation	227
INVERTER ASSEMBLY	84	Controller Circuit Board Installation	229
Parts List	84	Synthesizer Circuit Board Installation	236
Step-by-Step Assembly	86	IF Circuit Board Installation	239
IF CIRCUIT BOARD	94	IF Alignment	241
Parts List	94	RF Circuit Board Installation	242
Step-by-Step Assembly	96	Synthesizer Alignment	245
		Controller Alignment	247
		RF Circuit Board Alignment	248
		PA Assembly Installation	251
		FINAL ASSEMBLY	256

INTRODUCTION

The Heathkit Model HW-5400 HF SSB Transceiver covers the high-frequency amateur bands (plus approximately 50 kHz above and below each band edge) from 3.5 to 29.7 MHz. This microprocessor-based Transceiver is entirely solid-state and delivers 100 watts to a 50-ohm load (80 watts on 10 meters). Broadbanded circuits eliminate the necessity to "tune" circuits within a band. Just turn the bandswitch and select the desired frequency.

A digital readout displays the operating frequency directly to the nearest 50 Hz. A crystal-controlled time base provides high accuracy on all bands and eliminates the need for a calibrator. A smoked window covers the frequency display and provides subdued lighting with high visibility.

Vox Delay, Vox Gain, Sidetone, and Anti-Vox controls are conveniently located on the front panel to facilitate adjustments for operators who work both CW and SSB. Vox or PTT operation is switch-selectable, and you can switch the AGC action to Fast or Slow. Jacks are provided on the rear panel for ALC input from an amplifier, and for remote switching of an amplifier between transmit and receive. The front panel meter indicates signal strength in receive and ALC level in transmit.

Power for the Transceiver can be furnished by a power supply, such as the Heathkit Model HWA-5400-1, or directly from any regulated 13.8 VDC source.

To calibrate this Transceiver you need a high input impedance volt-ohmmeter, a frequency counter, a 50-ohm dummy load capable of dissipating 100 watts of power, and an RF wattmeter.

The following features are also included in your Transceiver:

- A microprocessor that controls the entire operation of the Transceiver.
- An optical tuning encoder for smooth, linkage-free tuning with no backlash.
- Memory on each band. The internal memory stores the frequency indicated on the display and an additional frequency on each band. This results in a total of sixteen selectable frequencies stored in RAM (random access memory). Also, a keep-alive voltage from the optional Power Supply Accessory retains the memory even when the Transceiver is turned off.
- Two sideband filters (one optional) for excellent receiver selectivity.
- Adjustable passband shift to help reduce adjacent-frequency interference.
- A VSWR-protected power amplifier.
- An internal diagnostic capability that indicates phase-locked loop malfunctions on the display.

The following accessories are available for use with your Transceiver:

- The model HWA-5400-1 AC-operated power supply/clock/speaker combination, which is housed in an attractive color-coordinated cabinet to match the styling of the Transceiver. A keep-alive memory voltage is provided by the power supply.
- The model HWA-5400-2 2.0 kHz SSB filter.
- The model HWA-5400-3 11-button keypad, which allows you to quickly enter any desired frequency. This accessory mounts directly into the Transceiver front panel.

UNPACKING INSTRUCTIONS

DO NOT UNPACK YOUR KIT UNTIL YOU ARE INSTRUCTED TO DO SO.

The main shipping carton for your HF SSB Transceiver contains a smaller carton that is marked "Packs 1-14 Top." After you remove this smaller carton, the packs still remaining in the main carton form the "Final Pack." This pack contains items that are too large to fit into other parts packs, and those items you will use in the assembly of the chassis. Do not remove any parts from the Final Pack unless you are specifically instructed to do so.

When you open the carton marked "Packs 1-14 Top," you will find a "Pack Index Sheet." This sheet shows you how the carton is divided into several compartments, which are referred to in this Manual as "packs." Each of these packs may be made up of loose parts, small boxes, or bags.

An instruction at the beginning of each Parts List instructs you which pack to open. You may also be instructed to remove certain parts from the "Final Pack."

ASSEMBLY NOTES

TOOLS

You will need these tools to assemble your kit.

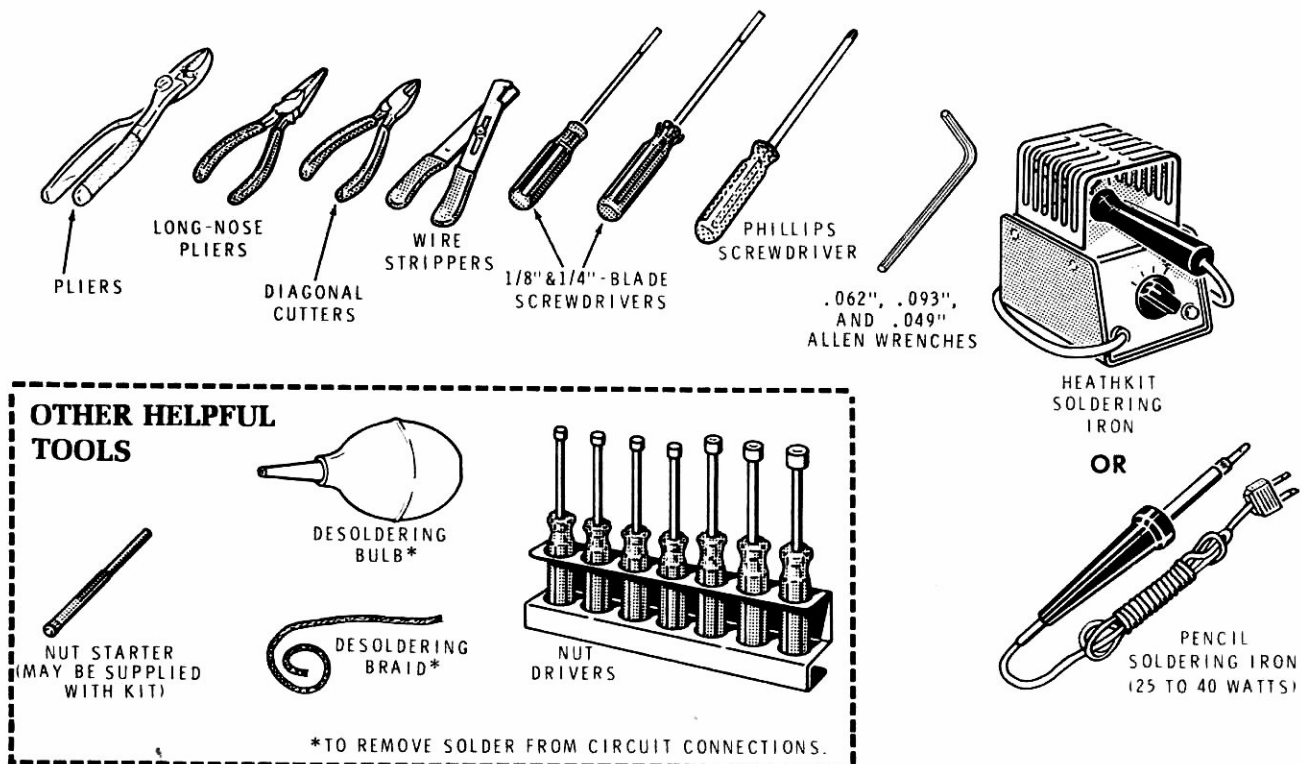

ASSEMBLY

1. Follow the instructions carefully. Read the entire step before you perform each operation.
2. The illustrations in the Manual are called Pictorials and Details. Pictorials show the overall operation for a group of assembly steps; Details generally illustrate a single step. When you are directed to refer to a certain Pictorial "for the following steps," continue using that Pictorial until you are referred to another Pictorial for another group of steps.
3. Most kits use a separate "Illustration Booklet" that contains illustrations (Pictorials, Details, etc.) that are too large for the Assembly Manual. Keep the "Illustration Booklet" with the Assembly Manual. The illustrations in it are arranged in Pictorial number sequence.
4. Position all parts as shown in the Pictorials.
5. Solder a part or a group of parts only when you are instructed to do so.

6. Each circuit part in an electronic kit has its own component number (R2, C4, etc.). Use these numbers when you want to identify the same part in the various sections of the Manual. These numbers, which are especially useful if a part has to be replaced, appear:
- In the Parts List,
 - At the beginning of each step where a component is installed,
 - In some illustrations,
 - In the Schematic,
 - In the section at the rear of the Manual.
7. When you are instructed to cut something to a particular length, use the scales (rulers) provided at the bottom of the Manual pages.

SAFETY WARNING: Avoid eye injury when you cut off excessive lead lengths. Hold the leads so they cannot fly toward your eyes.

SOLDERING

Soldering is one of the most important operations you will perform while assembling your kit. A good solder connection will form an electrical connection between two parts, such as a component lead and a circuit board foil. A bad solder connection could prevent an otherwise well-assembled kit from operating properly.

It is easy to make a good solder connection if you follow a few simple rules:

1. Use the right type of soldering iron. A 25 to 40-watt pencil soldering iron with a 1/8" or 3/16" chisel or pyramid tip works best.
2. Keep the soldering iron tip clean. Wipe it often on a wet sponge or cloth; then apply solder to the tip to give the entire tip a wet look. This process is called tinning, and it will protect the tip and enable you to make good connections. When solder tends to "ball" or does not stick to the tip, the tip needs to be cleaned and retinned.

NOTE: Always use rosin core, radio-type solder (60:40 or 50:50 tin-lead content) for all of the soldering in this kit. This is the type we have supplied with the parts. The Warranty will be void and we will not service any kit in which acid core solder or paste has been used.

PARTS

Resistors are identified in Parts Lists and steps by their resistance value in Ω (ohms), $k\Omega$ (kilohms), or $M\Omega$ (megohms). They are usually identified by a color code and four or five color bands, where each color represents a number. These colors (except for the last band, which indicates a resistor's "tolerance") will be given in the steps in their proper order. Therefore, the following color code is given for information only. NOTE: Occasionally, a "precision" or "power" resistor may have the value stamped on it.

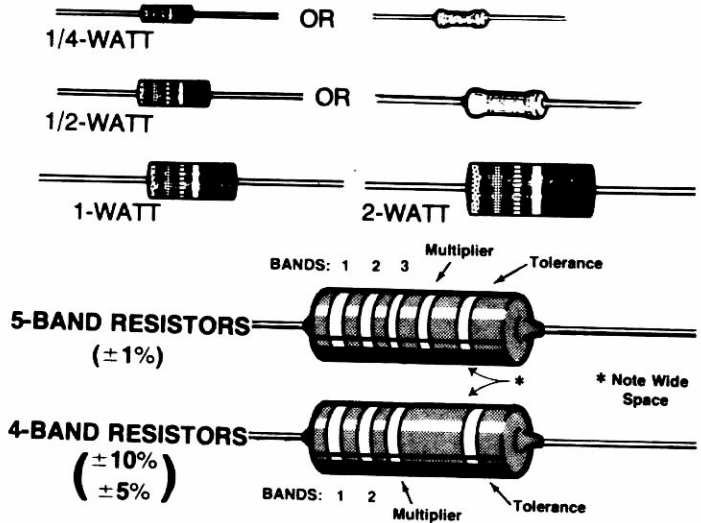

Band 1 1st Digit	
Color	Digit
Black	0
Brown	1
Red	2
Orange	3
Yellow	4
Green	5
Blue	6
Violet	7
Gray	8
White	9

Band 2 2nd Digit	
Color	Digit
Black	0
Brown	1
Red	2
Orange	3
Yellow	4
Green	5
Blue	6
Violet	7
Gray	8
White	9

Band 3 (if used) 3rd Digit	
Color	Digit
Black	0
Brown	1
Red	2
Orange	3
Yellow	4
Green	5
Blue	6
Violet	7
Gray	8
White	9

Multiplier	
Color	Multiplier
Black	1
Brown	10
Red	100
Orange	1,000
Yellow	10,000
Green	100,000
Blue	1,000,000
Silver	0.01
Gold	0.1

Resistance Tolerance	
Color	Tolerance
Silver	± 10%
Gold	± 5%
Brown	± 1%

Capacitors will be called out by their capacitance value in μF (microfarads) or pF (picofarads) and type: ceramic, Mylar*, electrolytic, etc. Some capacitors may have their value printed in the following manner:

EXAMPLES:

151K = $15 \times 10 = 150 \text{ pF}$
 759 = $75 \times 0.1 = 7.5 \text{ pF}$

NOTE: The letter "R" may be used at times to signify a decimal point: as in: 2R2 = 2.2 (pF or μF).

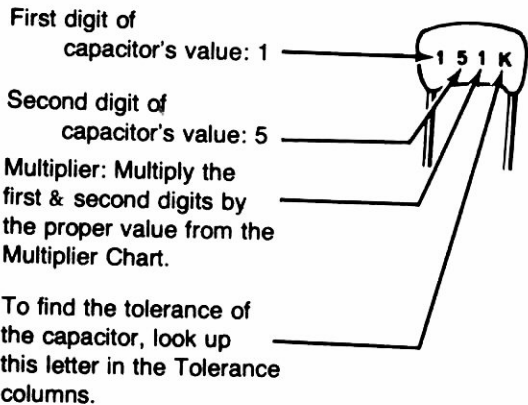

MULTIPLIER		TOLERANCE OF CAPACITOR		
FOR THE NUMBER:	MULTIPLY BY:	10 pF OR LESS	LETTER	OVER 10 pF
0	1	±0.1 pF	B	
1	10	±0.25 pF	C	
2	100	±0.5 pF	D	
3	1000	±1.0 pF	F	±1%
4	10,000	±2.0 pF	G	±2%
5	100,000		H	±3%
			J	±5%
8	0.01		K	±10%
9	0.1		M	±20%

*DuPont Registered Trademark

SPECIAL ASSEMBLY NOTES

NOTE: The following suggestions will not necessarily improve the operation of your Transceiver. They will, however, help you troubleshoot the Transceiver (if it ever becomes necessary), and help you perform the "Circuit Board Checkout" steps at the end of many of the assembly sections of this Manual. And, you will have a more professionally-built Transceiver when you finish.

1. When you install resistors, always position each resistor so you can read the bands on the resistor in the same direction as you can read the printing on the circuit board (see Figure 1). For resistors that have the value printed on them instead of color bands, install these resistors so the values are facing away from the circuit board and read in the same direction as the printing on the circuit board.

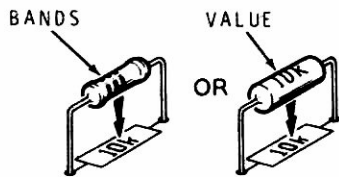

Figure 1

2. When you install ceramic, Mylar, or mica capacitors, always position each capacitor so you can read the value on the capacitor in the same direction as you can read the printing on the circuit board (see Figure 2).

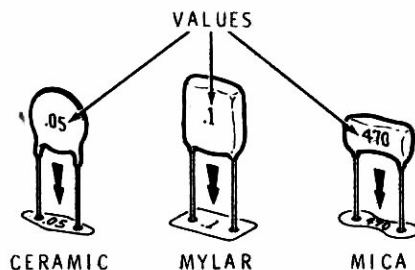

Figure 2

3. When you install electrolytic or other tubular capacitors, always position each capacitor so the value is facing away from the circuit board (see Figure 3). Be sure to observe the correct polarity when you install electrolytic capacitors (as you will be directed in the steps). Other, non-polarized, capacitors should be installed so you can read the values in the same direction as the printing on the circuit board.

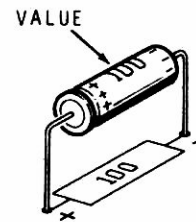

Figure 3

4. Install diodes so the type numbers or part numbers are facing away from the circuit board. Be sure to match the band on one end of each diode with the band mark on the circuit board.
5. Install chokes that have color bands or values printed on them in the same manner as resistors.

SHAFT ENCODER & RF PROBE CIRCUIT BOARDS

PARTS LIST

() Refer to the Pack Index Sheet and locate Pack #1. Then remove the parts from this pack and check each part against the following list. The key numbers correspond to the numbers on the "Shaft Encoder & RF Probe Circuit Boards Parts Pictorial" (Illustration Booklet, Page 1). Return any part that is packed in an individual envelope, with the part number on it, back into its envelope until that part is called for in a step.

Do not throw away any packing material until you account for all the parts.

To order a replacement part, always include the PART NUMBER. Use the Parts Order Form furnished with this kit. If a Parts Order Form is not available, refer to "Replacement Parts" inside the rear cover of this Manual. For prices, refer to the separate "Heath Parts Price List."

KEY No.	HEATH Part No.	QTY.	DESCRIPTION	CIRCUIT Comp. No.
---------	----------------	------	-------------	-------------------

ELECTRONIC COMPONENTS

NOTE: The following resistors are rated at 1/4-watt and have a tolerance of 5% (fourth band gold).

A1	6-151-12	2	150 Ω (brn-gm-brn) resistor	R601, R602
A2	21-176	1	.01 μF ceramic capacitor	C1
A2	21-192	1	.1 μF (104M) ceramic capacitor	C2
A3	56-26	2	1N191 diode	D1, D2
A4	150-74	2	Optical coupler	U601, U602

WIRE — SLEEVING

340-3	12'	Large bare wire
340-8	5'	Small bare wire
343-15	13' 6"	Black shielded cable

KEY No.	HEATH Part No.	QTY.	DESCRIPTION	CIRCUIT Comp. No.
---------	----------------	------	-------------	-------------------

Wire — Sleaving (Cont'd.)

343-25	8' 10"	White shielded cable
344-16	2'	Medium red stranded wire
344-59	30"	White solid wire
344-82	24"	Medium white stranded wire
344-118	18"	Large red stranded wire
344-146	6"	Large white stranded wire
344-180	4' 6"	Small white-violet solid wire
346-1	6"	Small black sleeving
346-4	6"	Fiber sleeving
346-21	2-3/8"	Teflon® sleeving
346-35	30"	Medium heat-shrinkable sleeving
347-66	30"	25-wire flat cable
348-6	2'	Enameled wire

Heathkit®

KEY No.	HEATH Part No.	QTY.	DESCRIPTION	CIRCUIT Comp. No.	KEY No.	HEATH Part No.	QTY.	DESCRIPTION	CIRCUIT Comp. No.
MISCELLANEOUS					PARTS FROM THE FINAL PACK				
	85-2729-1	1	Shaft encoder circuit board		C1	390-2068	1	Plain label*	
	85-2739-2	1	RF probe circuit board		C2	390-2264	1	Door label*	
B1	204-9	2	Angle bracket		C3		1	Blue and white label*	
B2	250-1411	2	4-40 × 1/4" black phillips head screw		C4	390-2363	1	Label sheet	
B3	250-1412	4	4-40 × 3/8" black phillips head screw			597-260	1	Parts Order Form*	
B4	252-2	6	4-40 nut				1	Assembly Manual (See Page 1 for the part number.)	
B5	254-9	6	#4 lockwasher				1	Operation Manual (See Page 1 for the part number.)	
B6	253-43	4	#5 fiber flat washer						
B7	260-16	1	Alligator clip						
B8	432-123	1	Circuit board sleeve						
B9	490-5	1	Nut starter						
			Solder						

* These items are packed inside the Manual. Set them aside until they are called for later.

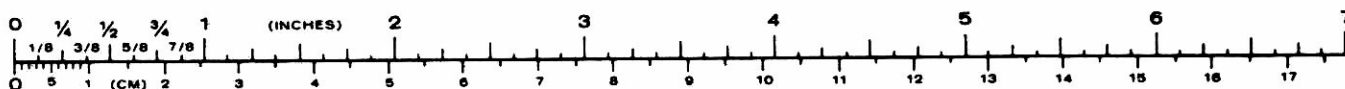

STEP-BY-STEP ASSEMBLY

SHAFT ENCODER CIRCUIT BOARD

START ◀

In the following steps, you will be given detailed instructions on how to install and solder the first part on the circuit board. Read and perform each step carefully. Then use the same procedure whenever you install parts on a circuit board.

- () Position the shaft encoder circuit board as shown with the printed side (not the foil side) up.

NOTE: When you install a component that has its value printed on it, position the value marking up, so it can be easily read. Diodes should be mounted with their type or part number up, if possible.

- () Hold a 150 Ω (brn-grn-brn) resistor with long-nose pliers and bend the leads straight down to fit the hole spacing on the circuit board.

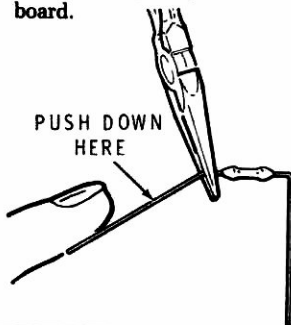

- () R601: Push the leads through the holes at the indicated location on the circuit board. The end with color bands may be positioned either way.

- () Press the resistor against the circuit board. Then bend the leads outward slightly to hold the resistor in place.

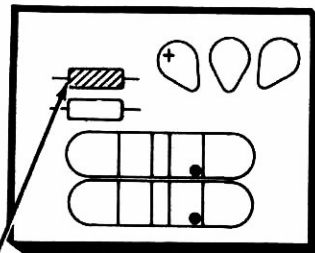

PICTORIAL 1-1

CONTINUE ▶

- () Solder the resistor leads to the circuit board as follows:

1. Push the soldering iron tip against both the lead and the circuit board foil. Heat both for two or three seconds.

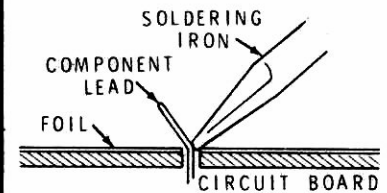

2. Then apply solder to the other side of the connection. **IMPORTANT:** Let the heated lead and the circuit board foil melt the solder.

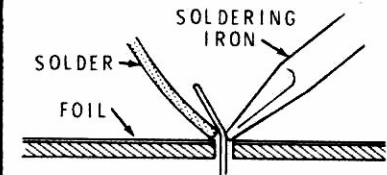

3. As the solder begins to melt, allow it to flow around the connection. Then remove the solder and the iron and let the connection cool.

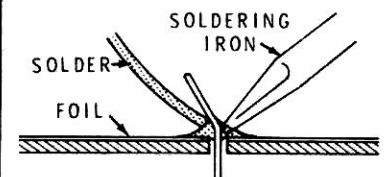

- () Cut off the excess lead lengths close to the connection. **WARNING:** Clip the leads so the ends will not fly toward your eyes.

- () Check each connection. Compare it to the illustrations on Page 13. After you have checked the solder connections, proceed with the assembly on Page 14. Use the same soldering procedure for each connection.

A GOOD SOLDER CONNECTION

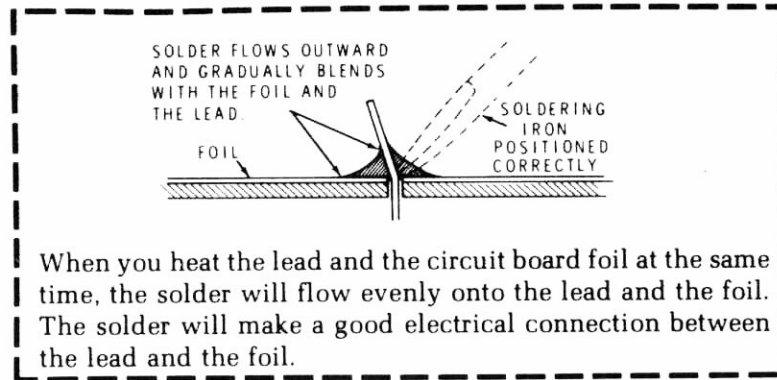

POOR SOLDER CONNECTIONS

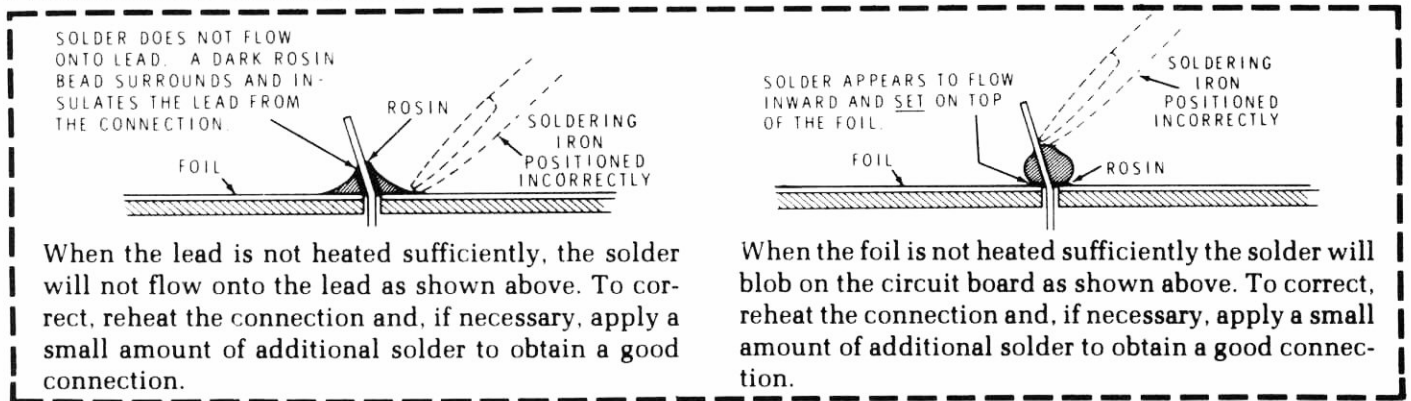

SOLDER BRIDGES

A solder bridge between two adjacent foils is shown in photograph A. Photograph B shows how the connection should appear. A solder bridge may occur if you accidentally touch an adjacent previously soldered connection, if you use too much solder, or if you "drag" the soldering iron across other foils as you remove it from the connection. A good rule to follow is: always take a good look at the foil area around each lead before you solder it. Then, when you solder the connection, make sure the solder remains in this area and does not bridge to another foil. This is especially important when the foils are small and close together. NOTE: It is alright for solder to bridge two connections on the same foil.

Use only enough solder to make a good connection, and lift the soldering iron straight up from the circuit board. If a solder bridge should develop, turn the circuit board foil-side-down and heat the solder between connections. The excess solder will run onto the tip of the soldering iron, and this will remove the solder bridge. NOTE: The foil side of most circuit boards has a coating on it called "solder resist." This is a protective insulation to help prevent solder bridges.

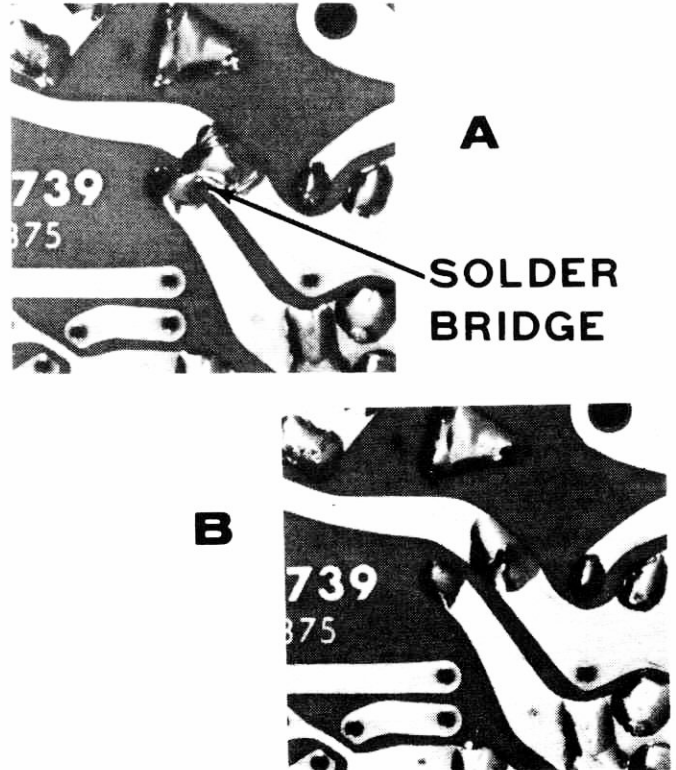

START →

NOTE: Make sure you installed resistor R601 as directed in Pictorial 1-1 on Page 12.

() R602: 150 Ω (brn-grn-brn).

() Solder the leads to the foil and cut off the excess lead lengths.

NOTES:

1. When hardware is called for in a step, only the screw size will be given. For instance, if 4-40 × 3/8" phillips head hardware is called for, use a 4-40 × 3/8" phillips head screw, one or more #4 lockwashers, and a 4-40 nut. The Pictorial or Detail will show the number of lockwashers to use.
2. Use the nut starter supplied with the kit to hold and start 4-40 and 6-32 nuts on screws.

In the next two steps, mount the optical couplers on the top of the circuit board, making sure each is positioned as shown in Part A or Part B of Detail 1-2A. Secure each part to the circuit board with two sets of 4-40 × 3/8" phillips head hardware and #5 fiber flat washers. Be sure to install the flat washers between the lockwashers and the circuit board foils as shown. Then solder the leads to the foil and cut off the excess lead lengths.

() U601: Optical coupler (#150-74).

() U602: Optical coupler (#150-74).

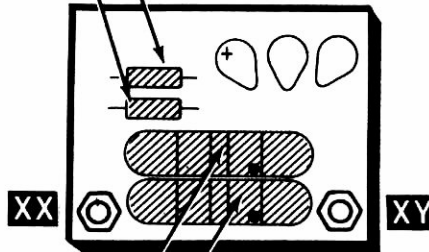

PICTORIAL 1-2

CONTINUE →

- () Secure the non-threaded side of an angle bracket to the foil side of the circuit board with 4-40 × 1/4" black phillips head hardware at hole XX. Be sure the bracket is even with the bottom edge of the circuit board as shown.

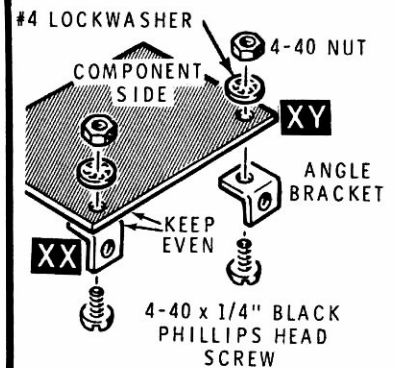

- () In the same manner, install another angle bracket at XY.

- () Set the circuit board aside temporarily.

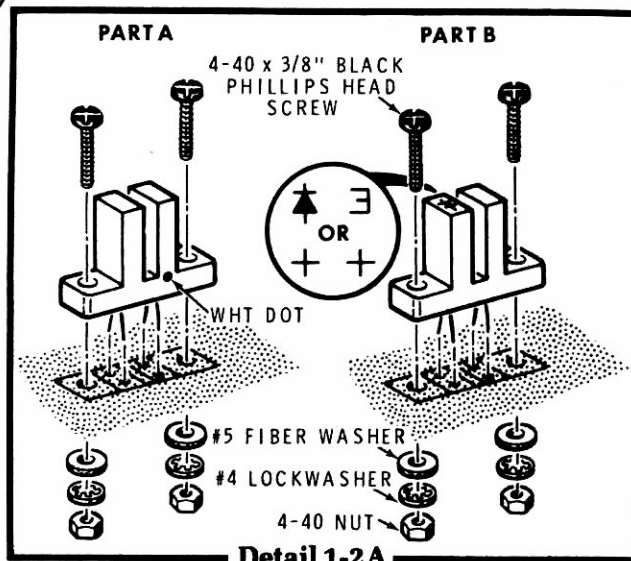

Detail 1-2A

RF PROBE CIRCUIT BOARD

START

Position the RF probe circuit board as shown. Then proceed with the following steps.

NOTE: When you install ceramic capacitors, do not push the insulated portion of the leads into the circuit board holes. This could make it difficult to solder the leads to the foil.

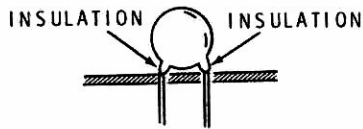

() C1: .01 μ F ceramic. Bend the indicated capacitor lead straight out from the end of the board as shown. **DO NOT CUT OFF THIS LEAD.**

NOTE: In this Pictorial, when you install diodes, form the leads as shown below. Mount the **unbanded** diode lead into the circled hole on the board.



() D1: 1N191 diode (#56-26).

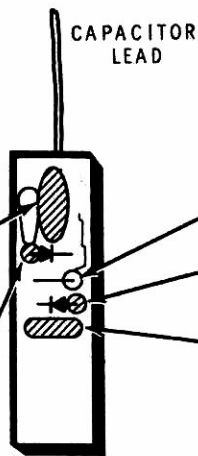

PICTORIAL 1-3

CONTINUE

() Do not install a component at this location.

() D2: 1N191 diode (#56-26). Mount the **unbanded** lead into the circled hole on the board.

() C2: .1 μ F (104M) ceramic capacitor.

() Solder the leads to the foil and cut off the excess lead lengths. **DO NOT CUT OFF THE INDICATED LEAD OF CAPACITOR C1.**

START ▾

() Refer to Detail 1-4A (Illustration Booklet, Page 2) and cut eleven multi-wire cables from the 25-wire flat cable as shown. Set these cables aside for use throughout the kit.

() Separate the wires of the remaining cable into 25 separate wires. Use these wires whenever a step calls for small stranded wire.

NOTE: When a step directs you to prepare a stranded wire, as in the next step, first cut the wire to the indicated length and remove 1/4" of insulation from each end. Twist together the strands at each end of the wire. Then melt a small amount of solder onto these wire ends to hold the fine strands together.

() Prepare a 9" small black stranded wire. Then crimp and solder an alligator clip onto one end of the wire as shown.

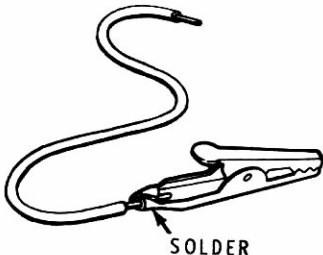

() Install the other end of the wire in the circuit board GND hole. Solder the wire to the foil and cut off the excess end.

ALLIGATOR CLIP

9" BLK



PICTORIAL 1-4

CONTINUE ▾

() Install a circuit board sleeve onto the foil side of the circuit board as follows:

1. Turn the circuit board foil side up as shown below and, if necessary, scrape any protective coating from the foil on the lower end of the board.
2. Melt a small amount of solder onto the bare foil area.
3. Position a circuit board sleeve onto the circuit board foil and heat the foil and the tab on the end of the sleeve. Add a small amount of solder if necessary.

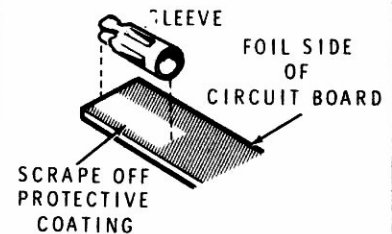
**CIRCUIT BOARD CHECKOUT**

Carefully inspect the foil side of the two small circuit boards for the following most commonly made errors.

- () Unsoldered connections.
- () Poor soldered connections.
- () Solder bridges between foil patterns.
- () Protruding leads which could touch together.

Refer to the illustrations where the parts were installed as you make the following visual checks.

- () Diodes for the correct position of the banded end.

This completes the assembly of the circuit boards. Set them aside until they are called for in a step.

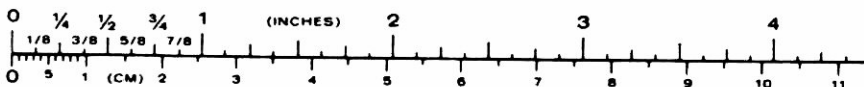
FINISH

FILTER CIRCUIT BOARD

PARTS LIST

() Refer to the Pack Index Sheet and locate Pack #2. Then remove the parts from this pack and check each part against the following list. The key numbers correspond to the numbers on the "Filter Circuit Board Parts Pictorial" (Illustration Booklet, Page 1). Return any part that is packed in an individual envelope, with the part number on it, back into its envelope until that part is called for in a step. Do not throw away

any packing material until you account for all the parts.

To order a replacement part, always include the PART NUMBER. Use the Parts Order Form furnished with this kit. If a Parts Order Form is not available, refer to "Replacement Parts" inside the rear cover of this Manual. For prices, refer to the separate "Heath Parts Price List."

KEY No.	HEATH Part No.	QTY.	DESCRIPTION	CIRCUIT Comp. No.
---------	----------------	------	-------------	-------------------

RESISTORS

NOTES:

- Resistors may be packed in more than one envelope. Open all of the resistor envelopes in this pack before you check the resistors against the following Parts List.
- The following resistors are rated at 1/4-watt and have a tolerance of 5% (fourth band gold) unless otherwise noted.

A1	6-279	1	2.7 Ω, 1/2-watt (red-viol-gold)	R556
A2	6-100-12	1	10 Ω (brn-blk-blk)	R561
A2	6-331-12	1	330 Ω (org-org-brn)	R551
A2	6-471-12	1	470 Ω (yel-viol-brn)	R552
A2	6-102-12	2	1000 Ω (brn-blk-red)	R557, R559
A2	6-332-12	1	3300 Ω (org-org-red)	R558
A2	6-822-12	1	8200 Ω (gry-red-red)	R553
A2	6-103-12	2	10 kΩ (brn-blk-org)	R555, R562
A2	6-183-12	1	18 kΩ (brn-gry-org)	R554

KEY No.	HEATH Part No.	QTY.	DESCRIPTION	CIRCUIT Comp. No.
---------	----------------	------	-------------	-------------------

CAPACITORS

Mica

B1	20-101	4	47 pF	C552, C553, C556, C557
B1	20-76	3	68 pF	C559, C564, C571
B1	20-110	2	75 pF	C558, C563
B1	20-119	1	90 pF	C569
B1	20-102	3	100 pF	C554, C555, C566
B1	20-177	2	125 pF	C565, C572
B1	20-189	1	140 pF	C561
B1	20-103	3	150 pF	C568, C573, C575
B1	20-178	1	160 pF	C562
B1	20-105	1	180 pF	C567
B1	20-120	1	220 pF	C576
B1	20-185	3	240 pF	C577, C578, C583
B1	20-112	1	310 pF	C582
B1	20-116	2	400 pF	C579, C581
B1	20-707	1	470 pF	C574
B1	20-167	2	620 pF	C584, C587
B1	20-127	2	1300 pF	C585, C586

KEY No.	HEATH Part No.	QTY.	DESCRIPTION	CIRCUIT Comp. No.
---------	----------------	------	-------------	-------------------

KEY No.	HEATH Part No.	QTY.	DESCRIPTION	CIRCUIT Comp. No.
---------	----------------	------	-------------	-------------------

Ceramic

B2	21-150	1	820 pF	C595
B2	21-176	1	.01 μF	C589
B2	21-143	4	.05 μF	C551, C591, C593, C594

TRANSISTORS

NOTE: Transistors may be marked for identification in any of the following four ways:

1. Part number.
2. Type number.
3. Part number and type number.
4. Part number with a type number other than the one listed.

Electrolytic

B3	25-885	1	100 μF	C588
B3	25-905	1	470 μF	C592

E1	417-819	1	MJE171	Q554
E1	417-818	2	MJE181	Q551, Q555
E2	417-864	3	MPSA05	Q552, Q553, Q556

INDUCTORS

C1	40-2059	2	.55 μH toroid	L553, L554
C1	40-2060	2	1 μH toroid	L555, L556
C1	40-2009	2	1.34 μH toroid	L557, L558
C1	40-2062	2	1.6 μH toroid	L559, L561
C1	40-2063	3	3 μH toroid	L562, L563, L564

HARDWARE

F1	250-1411	2	4-40 × 1/4" black phillips head screw
F2	252-2	2	4-40 nut
F3	254-34	2	#4 lockwasher

DIODES

D1	56-56	2	1N4149	D551, D553
D1	56-620	1	1N4447A	D552
D1	56-58	1	1N5234B	D555
D1	56-616	1	1N5232B	D554

MISCELLANEOUS

G1	69-75	1	12-volt relay	K552
G2	69-87	1	5-volt relay	K551
G3	75-807	2	Transistor insulator	
	85-2689-3	1	Filter circuit board	
G4	206-1413	1	Large shield	
G5	206-1414	2	Small shield	
G6	352-31	1	Thermal compound	
G7	432-969	2	5-pin plug	P501, P503
G8	432-1265	2	3-pin plug	P502, P504
G9	475-15	1	Ferrite bead	

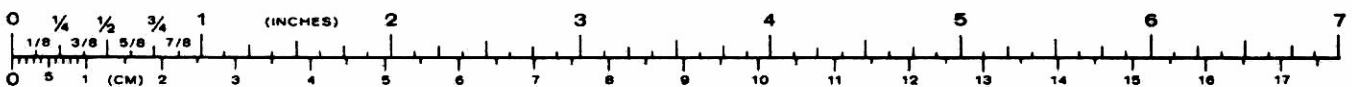

STEP-BY-STEP ASSEMBLY

START

() Position the circuit board as shown.

NOTE: DIODES MAY BE SUPPLIED IN ANY OF THE FOLLOWING SHAPES. ALWAYS POSITION THE BANDED END AS SHOWN ON THE CIRCUIT BOARD.

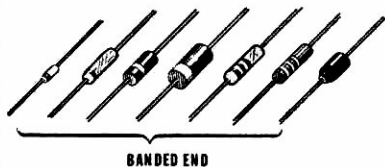

() D551: 1N4149 (#56-56).

() R551: 330Ω (org-org-brn).

() Cut a 1" length of small bare wire. Install the ferrite bead with the wire as shown.

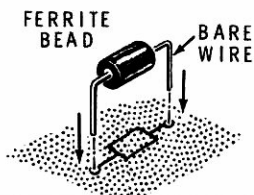

() R556: 2.7 Ω, 1/2 watt (red-viol-gold).

() R555: 10kΩ (brn-blk-org).

() R557: 1000 Ω (brn-blk-red).

() R558: 3300Ω (org-org-red).

() D554: 1N5232B (#56-616).

() D555: 1N5234B (#56-58).

() D553: 1N4149 (#56-56).

() D552: 1N4447A (#56-620).

() Solder the leads to the foil and cut off the excess lead lengths.

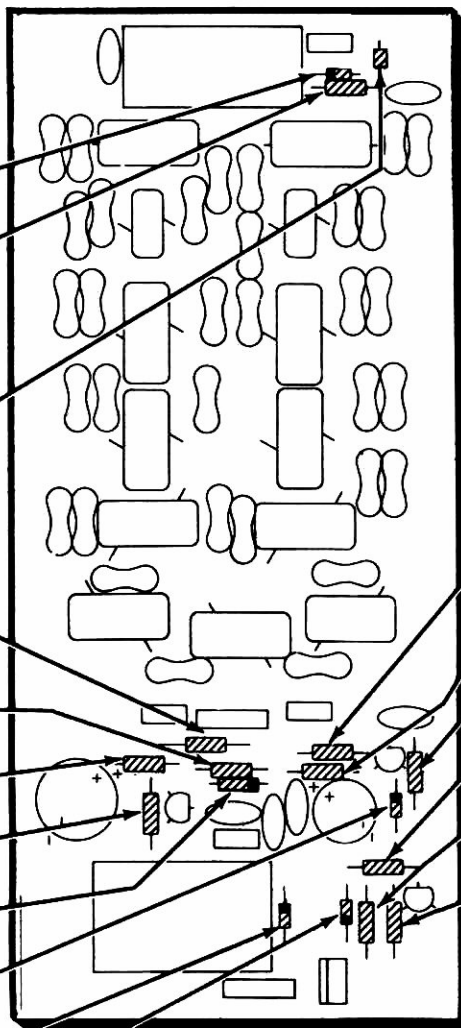

CONTINUE

() R552: 470 Ω (yel-viol-brn).

() R553: 8200 Ω (gry-red-red).

() R554: 18 kΩ (brn-gry-org).

() R562: 10k Ω (brn-blk-org).

() R559: 1000Ω (brn-blk-red).

() R561: 10Ω (brn-blk-blk).

() Solder the leads to the foil and cut off the excess lead lengths.

PICTORIAL 2-1

START ↘

() P554: 3-pin plug. Insert the small pins into the board and solder them to the foil.

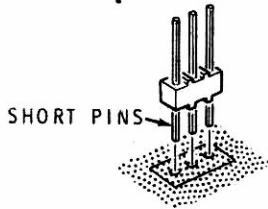

() P553: 5-pin plug.

() P552: 3-pin plug.

() P551: 5-pin plug.

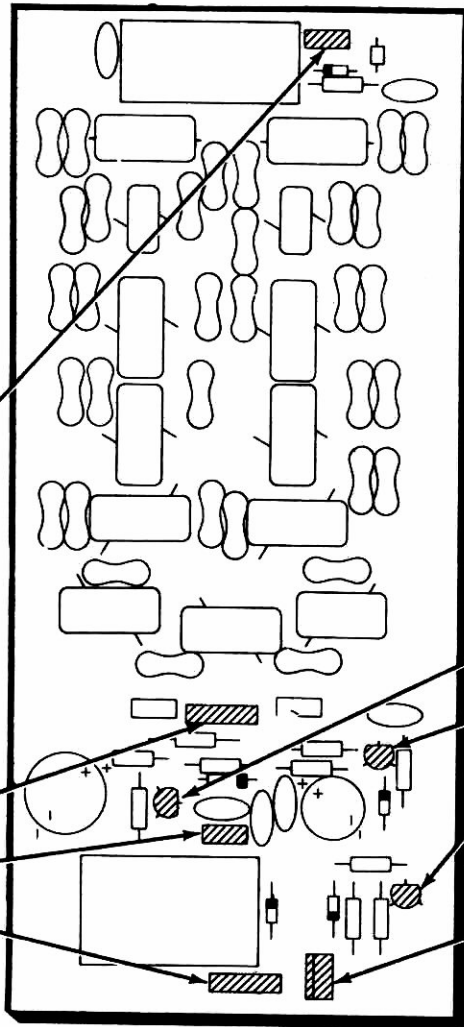

PICTORIAL 2-2

CONTINUE ↘

NOTE: When you install each of the following transistors, position the flat on the transistor over the outline of the flat on the circuit board. Then insert the leads into the circuit board holes and solder them to the foil. Cut off the excess lead lengths.

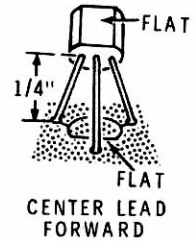

() Q553: MPSA05 (#417-864).

() Q556: MPSA05 (#417-864).

() Q552: MPSA05 (#417-864).

() Q551: MJE181 transistor (#417-818). Position the bare metal side toward the double-bar outline on the circuit board. Solder the leads to the foil and cut off the excess lead lengths.

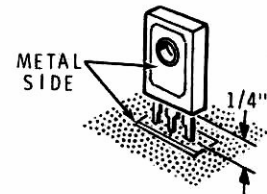

START →

- C595: 820 pF ceramic.
- C556: 47 pF mica.
- C557: 47 pF mica.
- C563: 75 pF mica.
- C564: 68 pF mica.
- C571: 68 pF mica.
- C569: 90 pF mica.
- C575: 150 pF mica.
- Solder the leads to the foil and cut off the excess lead lengths.
- C576: 220 pF mica.
- C583: 240 pF mica.
- C582: 310 pF mica.
- C587: 620 pF mica.
- C589: .01 μ F ceramic.
- C593: .05 μ F ceramic.
- C594: .05 μ F ceramic.
- C591: .05 μ F ceramic.
- Solder the leads to the foil and cut off the excess lead lengths.

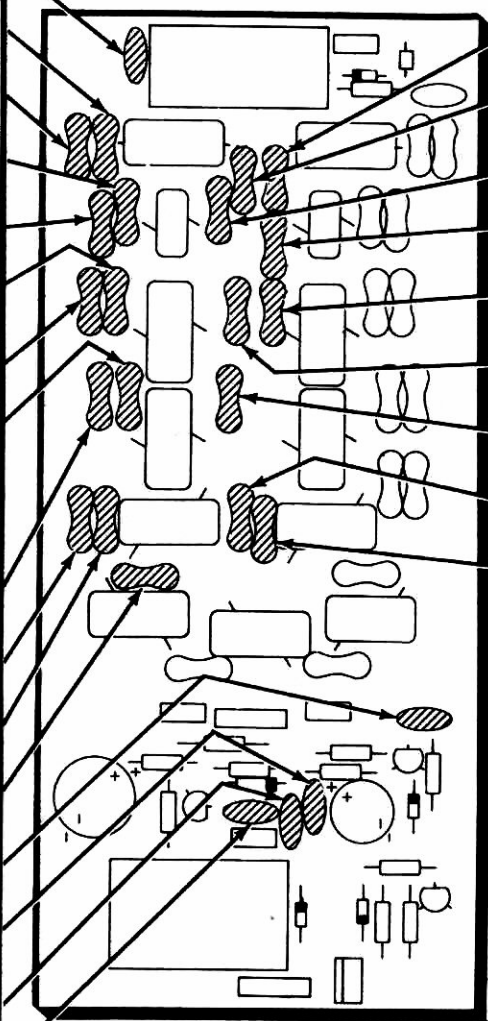

PICTORIAL 2-3

CONTINUE ↘

- C554: 100 pF mica.
- C555: 100 pF mica.
- C562: 160 pF mica.
- C561: 140 pF mica.
- C568: 150 pF mica.
- C567: 180 pF mica.
- C574: 470 pF mica.
- C581: 400 pF mica.
- C579: 400 pF mica.
- Solder the leads to the foil and cut off the excess lead lengths.

START ↘

- () C551: .05 μ F ceramic.
- () C553: 47 pF mica.
- () C552: 47 pF mica.
- () C559: 68 pF mica.
- () C558: 75 pF mica.
- () C566: 100 pF mica.
- () C565: 125 pF mica.
- () Solder the leads to the foil and cut off the excess lead lengths.
- () C573: 150 pF mica.
- () C572: 125 pF mica.
- () C578: 240 pF mica.
- () C577: 240 pF mica.
- () C584: 620 pF mica.
- () C586: 1300 pF mica.
- () C585: 1300 pF mica.
- () Solder the leads to the foil and cut off the excess lead lengths.

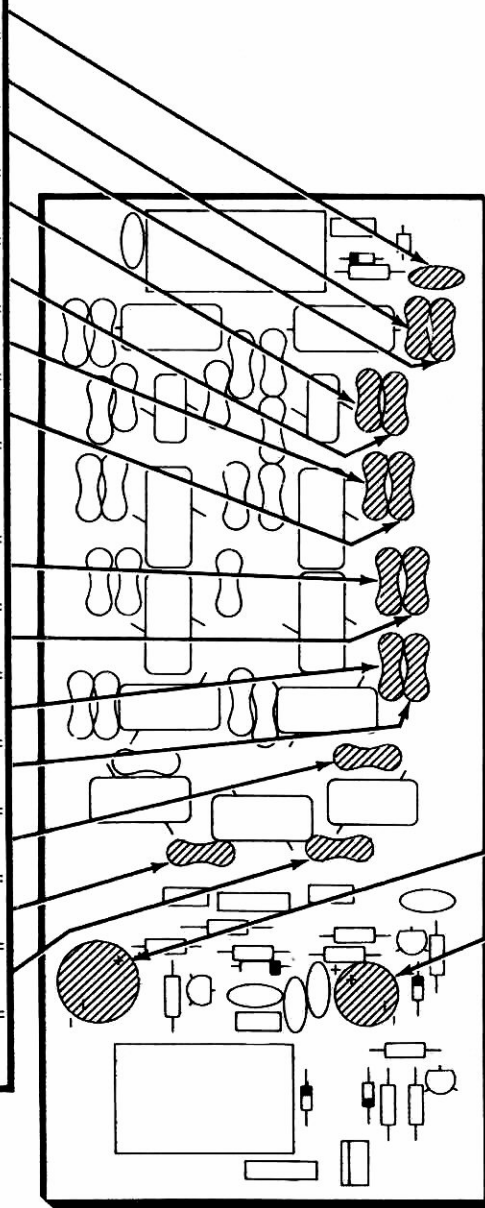
**CONTINUE** ↘

NOTE: when you install electrolytic capacitors, always match the positive (+) mark on the capacitor with the positive (+) mark on the circuit board OR match the minus (-) mark on the capacitor with the minus (-) mark on the circuit board.

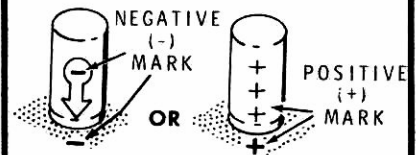

- () C592: 470 μ F electrolytic.
- () C588: 100 μ F electrolytic.
- () Solder the leads to the foil and cut off the excess lead lengths.

PICTORIAL 2-4

START ↘

() K551: 5-volt relay (#69-87). Position the relay with the mark as shown, insert the pins into the board, solder them to the foil, and cut off the excess lengths.

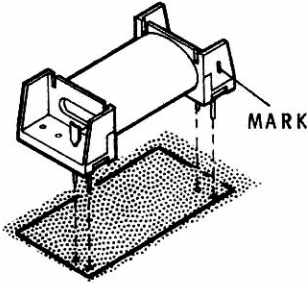

Prepare the next two coils by wrapping eight turns of enameled wire (count nine turns across the top) around the large end of the nut starter. Leave a 1/2" lead at each end and scrape the enamel from the leads. Then install the coils and solder the leads to the foil. Cut off the excess lead lengths. NOTE: Spread the turns of the coil as necessary to fit the circuit board hole.

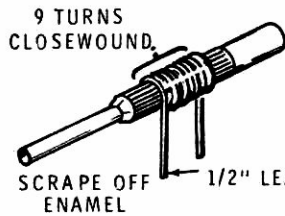

() L552: Coil.

() L551: Coil.

() K552: 12-volt relay (#69-75). Insert the pins into the board, solder them to the foil, and cut off the excess length.

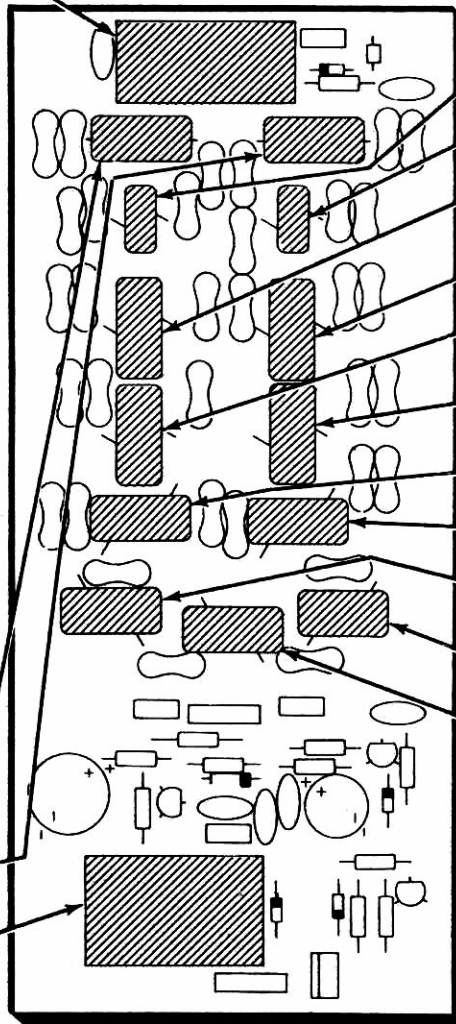

PICTORIAL 2-5

CONTINUE ↘

Install the following inductors as shown. Pre-form the leads as necessary to fit the circuit board spacing. Then insert the leads into the holes. Solder the leads to the foil and cut off the excess lead lengths.

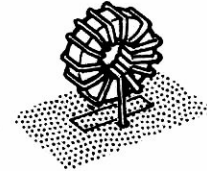

() L554: .55μH toroid (#40-2059).

() L553: .55μH toroid (#40-2059).

() L556: 1μH toroid (#40-2060).

() L555: 1μH toroid (#40-2060).

() L558: 1.34μH toroid (#40-2009).

() L557: 1.34μH toroid (#40-2009).

() L561: 1.6μH toroid (#40-2062).

() L559: 1.6μH toroid (#40-2062).

() L564: 3μH toroid (#40-2063).

() L562: 3μH toroid (#40-2063).

() L563: 3μH toroid (#40-2063).

FINISH

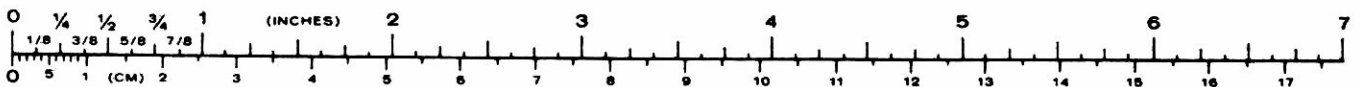

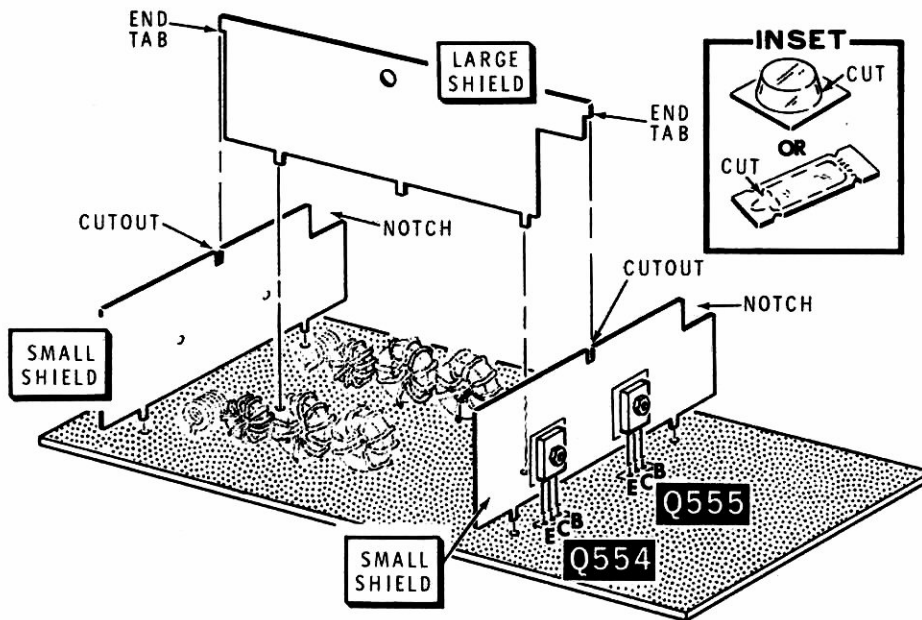

PICTORIAL 2-6

Refer to Pictorial 2-6 for the following steps.

() Q554: Refer to Detail 2-6A and position a small shield with the notch at one corner as shown. Then use the following procedure to mount an MJE171 transistor (#417-819) onto the shield at Q554:

1. Open the container of thermal compound (refer to the inset drawing on the Pictorial).
2. Apply a thin layer of thermal compound to both sides of a transistor insulator. Then position the insulator onto the shield at Q554 as shown.

3. Mount the transistor onto the shield at Q554 as shown. Use 4-40 × 1/4" black phillips head hardware. Be sure to position the transistor with the exposed metal side toward the insulator. As you tighten the hardware, keep the insulator and transistor parallel to the bottom edge of the shield.

() Similarly, mount an MJE181 transistor (#417-818) onto the shield at Q555. Save the remaining thermal compound for use later.

() Position the prepared shield with the notch as shown in the Pictorial. Then start the transistor leads and the tabs on the shield into their corresponding holes in the filter circuit board. Do not solder the tabs or transistor leads yet.

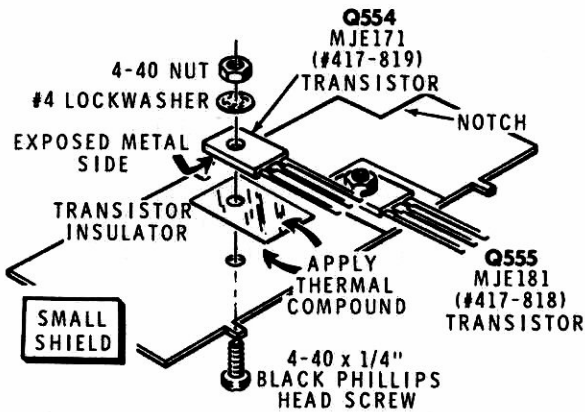

Detail 2-6A

- () Position the other small shield with the notch as shown. Then mount this shield onto the circuit board at the location shown. Make sure the shield is down tight against the circuit board. Then solder the two tabs to the foil.

- () Position the large shield as shown and mount it onto the circuit board as shown. Be sure the tab on each end of this shield fits into the corresponding cutout in the small shields.
- () Make sure the shields are down tight against the circuit board. Then solder the tabs to the foil. Also solder the transistor leads to the foil and cut off the excess lead lengths.
- () Solder the tab on each end of the large shield to the small shields.
- () Cut the following lengths of white shielded cable. The cables are listed in the order in which you will use them.

3-1/2"	7-1/4"
7-1/4"	6-1/4"
6-3/4"	5"
6-1/4"	4-1/8"
5-1/2"	3-1/8"
5-7/8"	3"
6"	

- () Cut thirteen 1" small bare wires.

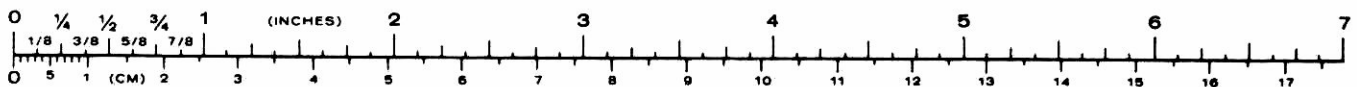

1. REMOVE 3/4" OF OUTER INSULATION WITH A SHARP BLADE. BE CAREFUL NOT TO CUT THROUGH THE SHIELD UNDER THE INSULATION.

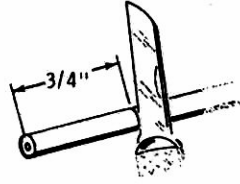

2. REMOVE 5/8" OF SHIELD.

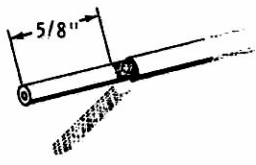

3. REMOVE 1/4" OF INNER INSULATION. TWIST THE FINE STRANDS OF WIRE TOGETHER AND APPLY SOLDER.

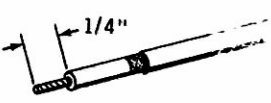

4. WRAP ONE END OF A 1" BARE WIRE AROUND THE SHIELD AND SOLDER IT.



Detail 2-7A

Refer to Pictorial 2-7 (Illustration Booklet, Page 3) for the following steps.

- () Refer to Detail 2-7A and prepare one end of each shielded cable as shown. This end of the cables will be referred to as "END A."
- () Refer to Detail 2-7B and prepare the free end of each shielded cable as shown. This end of the cables will be referred to as "END B."
- () Position the filter circuit board as shown in the Pictorial.
- () Connect **end A** of the 3-1/2" prepared shielded cable to the filter circuit board as follows. Solder the leads to the foil and cut off the excess lead lengths.

Inner lead to hole A.

Shield lead to hole B.

Connect **end A** of some of the prepared shielded cables to the holes along the **top edge** of the circuit board as follows. **NOTE:** When a step directs you to connect the shield lead (bare wire) to the GND hole, use the top row of holes. Solder the leads to the foil and cut off the excess lead lengths.

TAKING CARE NOT TO CUT THE OUTER SHIELD OF VERY THIN WIRES. REMOVE THE OUTER INSULATION.

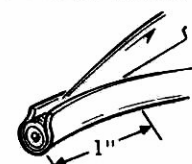

UNBRAID THE SHIELD WITH A NAIL OR POINTED TOOL AND TWIST THE SHIELD WIRES INTO ONE STRAND. REMOVE THE INNER INSULATION. THEN APPLY A SMALL AMOUNT OF SOLDER TO THE END OF THE SHIELD.

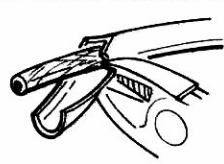
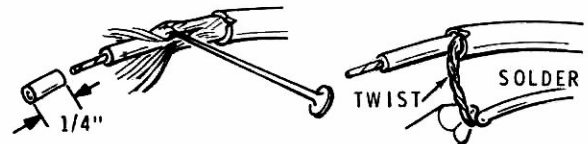
APPLY ONLY ENOUGH HEAT TO MELT SOLDER.

Detail 2-7B

- () 7-1/4" shielded cable: Inner lead to hole 80; shield lead to hole GND.
- () 6-3/4" shielded cable: Inner lead to hole 40; shield lead to hole GND.
- () 6-1/4" shielded cable: Inner lead to hole 30; shield lead to hole GND.
- () 5-1/2" shielded cable: Inner lead to hole 20; shield lead to hole GND.
- () 5-7/8" shielded cable: Inner lead to hole 15; shield lead to hole GND.
- () 6" shielded cable: Inner lead to hole 10; shield lead to hole GND.

NOTE: Connect end A of the following cables along the **bottom edge** of the filter circuit board. The ground holes for these cables are along the bottom edge of the circuit board. Exception: The GND hole for the cable at 80 is to the right of the number 80.

- () 7-1/4" shielded cable: Inner lead to hole 80; shield lead to hole GND.
- () 6-1/4" shielded cable: Inner lead to hole 40; shield lead to hole GND.
- () 5" shielded cable: Inner lead to hole 30; shield lead to hole GND.
- () 4-1/8" shielded cable: Inner lead to hole 20; shield lead to hole GND.
- () 3-1/8" shielded cable: Inner lead to hole 15; shield lead to hole GND.
- () 3" shielded cable: Inner lead to hole 10; shield lead to hole GND.

CIRCUIT BOARD CHECKOUT

Carefully inspect the circuit board for the following most commonly made errors:

- () Unsoldered connections.
- () Poor solder connections.
- () Solder bridges between foil patterns.

- () Protruding leads which could touch together.
- () Transistors for the proper type and installation.
- () Electrolytic capacitors for the correct position of the positive (+) lead.
- () Diodes for the correct position of the banded end.

INITIAL TESTS

NOTE: You will need a high input impedance volt-ohmmeter to perform the resistance checks for all of the circuit boards in your kit; a digital multimeter (DMM) may not produce the correct results. All readings, unless otherwise stated **must** be made with the common or negative ohmmeter lead connected to a circuit board ground. If you do not obtain the indicated resistance reading, carefully check the circuit board again for the correct installation of diodes, transistors, capacitors, etc. If you still cannot find the problem, carefully check the circuit board foils for open connections and solder bridges. It may be helpful to refer to the "Circuit Board X-Ray Views" in the Operation Manual when you check for solder bridges. In some cases, specific components may be indicated as a potential source of difficulty.

As you check some of the resistances, be sure to allow time for capacitors to charge; do not make the reading until the meter pointer has come to rest.

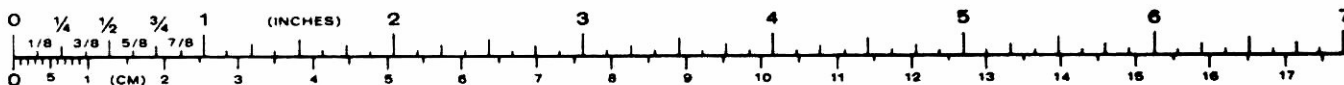

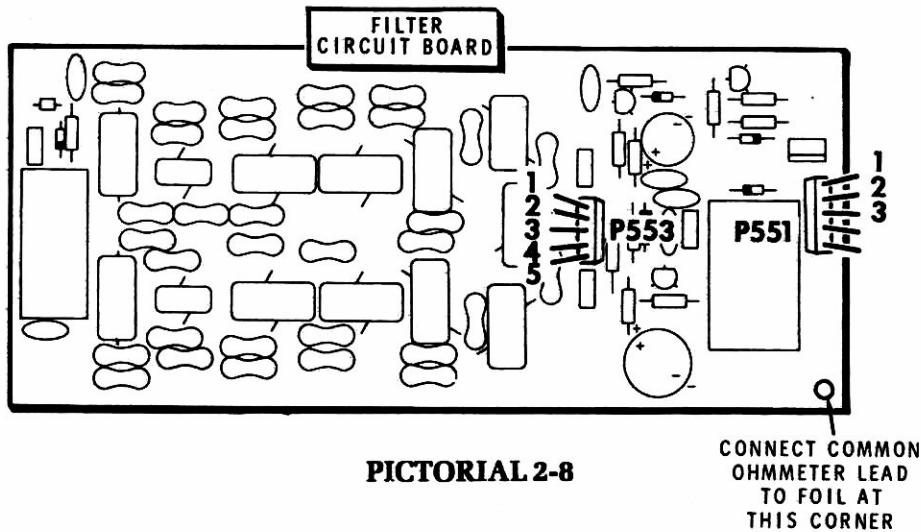

Refer to Pictorial 2-8 for the following steps.

() Connect the common ohmmeter lead to the bare circuit board foil at the indicated corner mounting hole.

() Set the ohmmeter to $R \times 10K$.

Use the positive ohmmeter probe to check for the indicated resistances at the following plug pins:

() P551, pin 1. Check for infinity. If the reading is incorrect, check transistor Q551 and its associated components.

() P551, pin 2. Check for infinity. If incorrect, check for correct installation of diode D552.

NOTE: In the following steps, the instructions will be abbreviated, as in the next example: The step will list

a test point, followed by the correct resistance reading, and (if applicable) a component to check if the reading is incorrect.

() P551-3. Infinity. Check Q551.

() P553-1. Charge to 50 k Ω or greater. Check Q555 or Q556.

() P553-2. Charge to approximately 30 k Ω . Check Q554 or Q555.

() P553-3. Infinity. Check D554.

() P553-4. Infinity. Check D554.

() P553-5. Charge to 60 k Ω or greater. Check Q554.

This completes the "Initial Tests" of your filter circuit board. Disconnect the ohmmeter leads from the circuit board. Then set the circuit board aside until it is called for later during the assembly of the chassis. Proceed to "Display Circuit Board."

DISPLAY CIRCUIT BOARD

PARTS LIST

() Refer to the Pack Index Sheet and locate Pack #3. Then remove the parts from this pack and check each part against the following list. The key numbers correspond to the numbers on the "Display Circuit Board Parts Pictorial" (Illustration Booklet, Page 3). Return any part that is packed in an individual envelope, with the part number on it, back into its envelope until that part is called for in a step. Do not throw away

any packing material until you account for all the parts.

To order a replacement part, always include the PART NUMBER. Use the Parts Order Form furnished with this kit. If a Parts Order Form is not available, refer to "Replacement Parts" inside the rear cover of this Manual. For prices, refer to the separate "Heath Parts Price List."

KEY No.	HEATH Part No.	QTY.	DESCRIPTION	CIRCUIT Comp No.
---------	----------------	------	-------------	------------------

RESISTORS

NOTES:

- Resistors may be packed in more than one envelope. Open all of the resistor envelopes in this pack before you check the resistors against the following Parts List.
- The following resistors are rated at 1/4-watt and have a tolerance of 5% (fourth band gold) unless otherwise noted.

A1	6-332-12	1	3300 Ω (org-org-red)	R207
A1	6-392-12	1	3900 Ω (org-wht-red)	R204
A1	6-562-12	1	5600 Ω (grn-blu-red)	R202
A1	6-104-12	2	100 kΩ (brn-blk-yel)	R205, R206

CONTROLS

B1	10-1141	1	Small 1000 Ω (1 kΩ)	R203
B1	10-1138	2	Small 10 kΩ	R201, R208
B2	10-148	4	Large 10 kΩ	R209, R211, R212, R213

KEY No.	HEATH Part No.	QTY.	DESCRIPTION	CIRCUIT Comp No.
---------	----------------	------	-------------	------------------

CAPACITORS

C1	21-710	1	47 pF ceramic	C201
C1	21-192	2	.1 μF (104M) ceramic	C202, C203

DIODES

D1	56-26	22	1N191 (brn-wht-brn)	D204, D209, D211, D212, D213, D214, D215, D216, D217, D218, D219, D221, D222, D223, D224, D225, D226, D227, D228, D229, D231, D232
D1	56-56	2	1N4149	D201, D202
D1	56-652	1	1N4448	D203

KEY No.	HEATH Part No.	QTY.	DESCRIPTION	CIRCUIT Comp. No.
---------	----------------	------	-------------	-------------------

KEY No.	HEATH Part No.	QTY.	DESCRIPTION	CIRCUIT Comp No.
---------	----------------	------	-------------	------------------

INTEGRATED CIRCUITS (ICs)

NOTES:

1. Integrated circuits may be marked for identification in any of the following four ways:
 - a. Part number.
 - b. Type number.
 - c. Part number and type number. (On integrated circuits, this refers only to the numbers; the letters may be different or missing.)
 - d. Part number with a type number other than the one listed.
2. Some of the ICs may be packed in conductive foam. Do not remove these ICs from the foam until a step directs you to do so.

E1	442-682	2	UDN6118A	U201, U202
E1	443-703	2	MC14001CP or CD4001BCN	U204, U205
E1	443-607	1	MC14013AL or CD4013BCN	U206
E1	443-701	1	MC14049CP or CD4049CN	U203
E1	443-807	1	74LS42	U207

CONNECTORS — SOCKETS

F1	432-120	5	Circuit board connector (includes one extra)
F2	432-121	1	Circuit board pin
F3	432-134	4	Wire socket (includes one extra)

Connectors — Sockets (Cont'd.)

F4	432-865	1	3-pin socket shell	
F5	432-866	24	Small spring connector (includes one extra)	
F6	432-903	2	10-pin plug	P204, P205
F7	432-921	1	3-pin socket	
F8	432-947	1	25-pin socket	
F9	432-1010	1	15-pin socket shell	
F10	432-1030	3	2-pin socket shell	
F11	432-1265	1	3-pin plug	
F12	434-298	3	14-pin IC socket	
F12	434-299	2	16-pin IC socket	
F12	434-310	2	18-pin IC socket	

MISCELLANEOUS

G1	411-857	1	Display tube	V201
G2	412-95	2	#3151 lamp	PL201, PL202
G3	73-39	6"	Foam tape	

FROM THE FINAL PACK

85-2644-2	1	Display circuit board
-----------	---	-----------------------

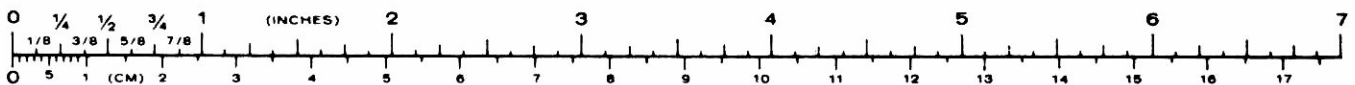

STEP-BY-STEP ASSEMBLY

() Position the circuit board as shown.

NOTE: You will install IC sockets in the following steps. Be sure the socket pins are straight. Insert the socket pins into the holes. The index mark on the circuit board must still be visible after it is installed. Solder the pins to the foil as you install each socket and cut off any excess pin lengths.

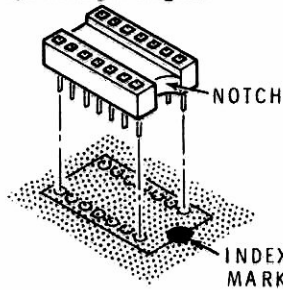

() 16-pin socket at U207.

() 18-pin socket at U201.

() 16-pin socket at U203.

() 18-pin socket at U202.

() 14-pin socket at U204. **NOTE:** When you install this socket, use just enough solder for a good connection and cut off the excess pins. This is to allow clearance for the meter.

() 14-pin socket at U206.

() 14-pin socket at U205. **NOTE:** When you install this socket, use just enough solder for a good connection and cut off the excess pins. This is to allow clearance for the meter.

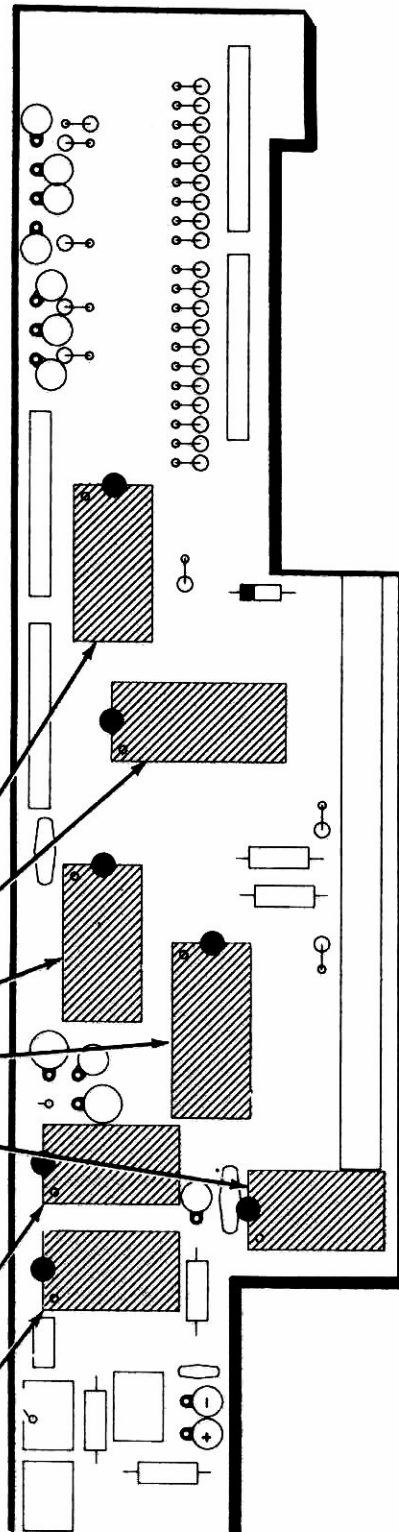

PICTORIAL 3-1

START ↘

NOTE: DIODES MAY BE SUPPLIED IN ANY OF THE FOLLOWING SHAPES. ALWAYS POSITION THE BANDED END AS SHOWN ON THE CIRCUIT BOARD.

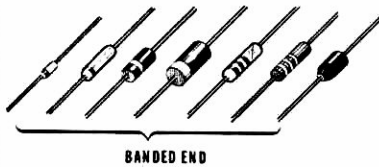

() D203: 1N4448 (#56-652).

() R205: 100kΩ (brn-blk-yel).

() R206: 100kΩ (brn-blk-yel).

() C203: .1μF (104M) ceramic.

() C202: .1μF (104M) ceramic.

() R207: 3300Ω (org-org-red).

() C201: 47pF ceramic.

() R202: 5600Ω (grn-blk-red).

() R204: 3900Ω (org-wht-red).

() Solder the leads to the foil and cut off the excess lead lengths. Be sure to cut off the leads of resistors R205 and R206 as close as possible to the circuit board. This is to allow clearance for the 25-pin socket that will be installed later.

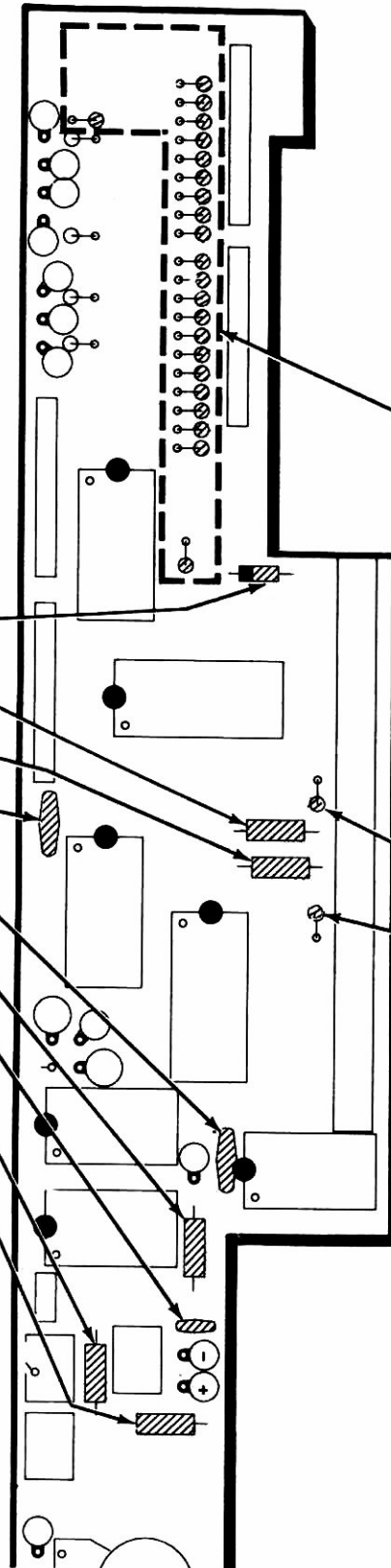

CONTINUE ↘

NOTE: When you install the following 1N191 (brn-wht-brn) diodes (#56-26), position them with the banded end DOWN over the circle as shown.

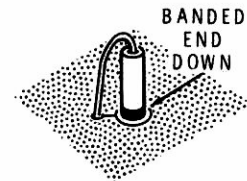

- | | |
|-----------|-----------|
| () D218. | () D219. |
| () D209. | () D223. |
| () D211. | () D224. |
| () D212. | () D225. |
| () D213. | () D226. |
| () D215. | () D227. |
| () D214. | () D228. |
| () D216. | () D229. |
| () D217. | () D231. |
| () D221. | () D232. |
| () D222. | () D204. |

NOTE: When you install the following 1N4149 (#56-56) diodes, position them with the banded end DOWN over the circle.

- () D201.
- () D202.

() Solder the leads to the foil and cut off the excess lead lengths. Be sure to cut off the leads of diodes D201 and D202 as close as possible to the circuit board. This is to allow clearance for the 25-pin socket that will be installed later.

PICTORIAL 3-2

START

NOTE: To install each of the following plugs, start the short pins into the board. Then push the plug down tight against the circuit board and solder the pins to the foil.

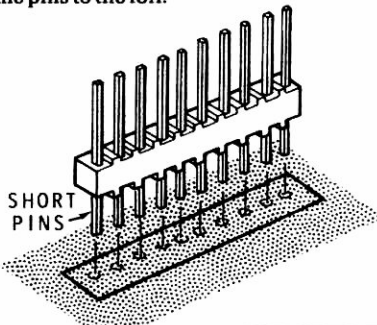

() P205: 10-pin plug.

() P204: 10-pin plug.

() P201: 3-pin plug.

NOTE: Install the following controls as shown. Use just enough solder to make a good connection and cut off the excess lugs.

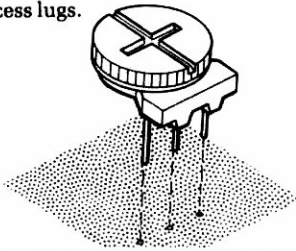

NOTE: Control R201 will be installed later.

() R208: Small 10 kΩ (# 10-1138).

() R203: Small 1000 Ω (1 kΩ) (#10-1141).

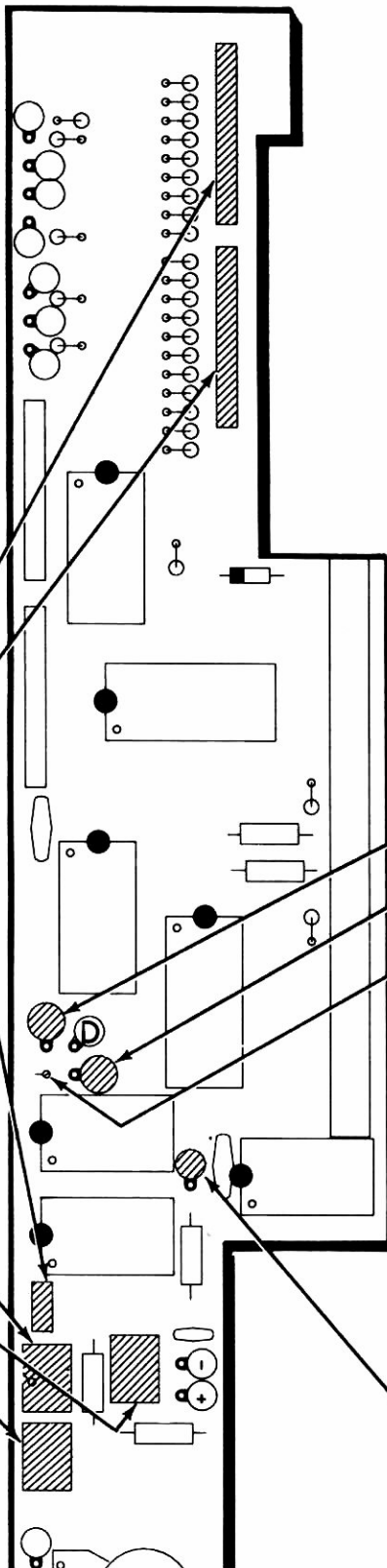

PICTORIAL 3-3

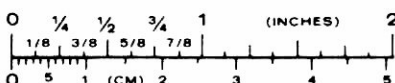

CONTINUE

NOTE: Install the following wire sockets as shown and solder them to the foil. Use a pencil eraser to push them into the hole.

CONNECTOR PIN

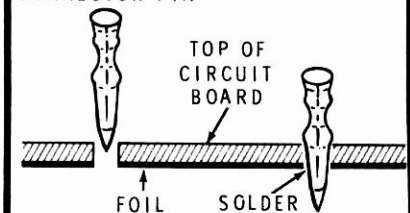

() Wire socket at HI.

() Wire socket at MED.

() Wire socket at OFF.

() Remove 1/4" of insulation from both ends of a 1-1/2" white solid wire. Insert one end into the wire socket at HI and the other end into hole D. Solder the wire at D and cut off the excess wire length.

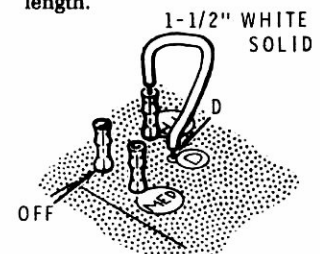

() Circuit board pin at C. Install the pin as shown and solder it to the foil.

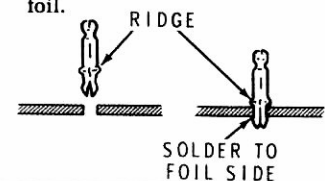

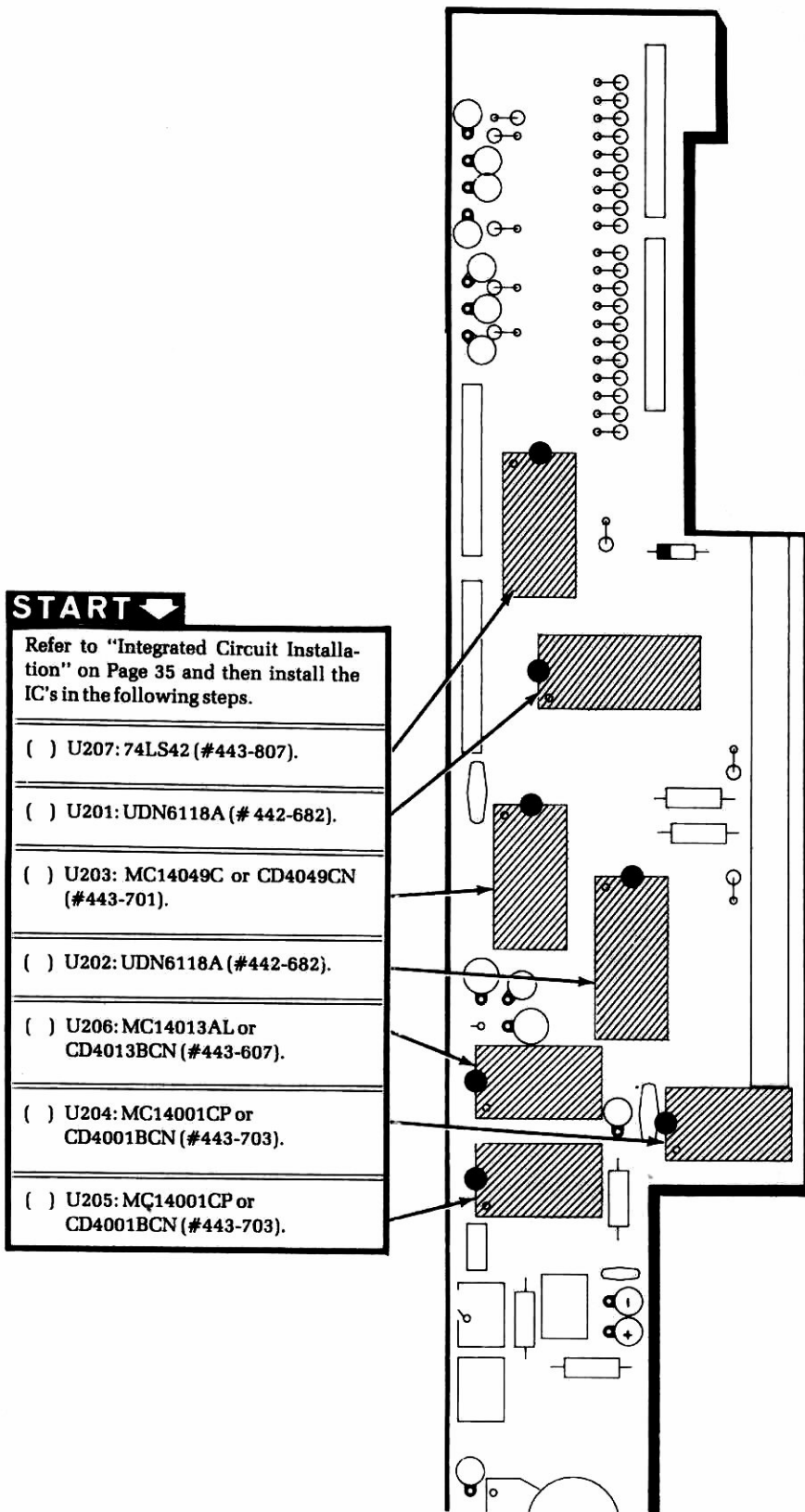

- START** ↓
- Refer to "Integrated Circuit Installation" on Page 35 and then install the IC's in the following steps.
- () U207: 74LS42 (#443-807).
 - () U201: UDN6118A (#442-682).
 - () U203: MC14049C or CD4049CN (#443-701).
 - () U202: UDN6118A (#442-682).
 - () U206: MC14013AL or CD4013BCN (#443-607).
 - () U204: MC14001CP or CD4001BCN (#443-703).
 - () U205: MC14001CP or CD4001BCN (#443-703).

PICTORIAL 3-4

INTEGRATED CIRCUIT INSTALLATION

CAUTION: Integrated Circuits (IC's) are complex electronic devices that perform many complicated functions in the circuit. However, these devices can be damaged by static electricity during installation. Use the following sequence, without interruption, when you are instructed to install ICs. (See Detail 3-4A).

1. Touch one hand to the conductive foam pad for those ICs packaged in foam; then remove the IC with the other hand.
2. Hold the IC and straighten any bent IC pins.
3. With your free hand, touch any foil area near the location where the IC is to be installed; then install the IC. Once it is installed, the IC is protected.

The pins on the IC's are bent out at an angle, so they will not line up with the holes in the IC socket. **DO NOT** try to install an IC without first bending the pins inward, or the pin or the socket may be damaged, causing intermittent contact.



The pin 1 end of inline integrated circuits may be marked in a number of ways; with a notch, triangle, dot, the numeral 1, etc.

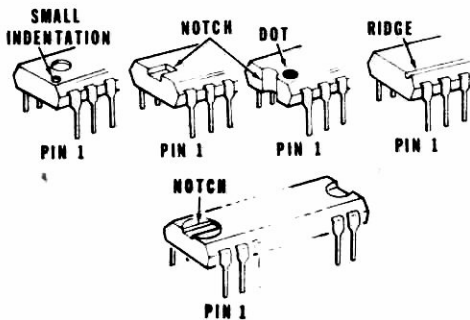

Position the pin 1 end of the integrated circuit toward the index mark on the circuit board. Then carefully install the integrated circuit. Make sure all the pins are in their respective holes.

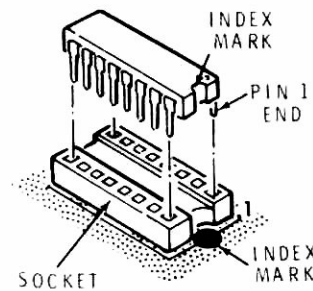

Before you install an IC, lay it down on its side as shown and very carefully roll it toward the pins to bend the lower pins into line. Then turn the IC over and bend the pins on the other side in the same manner.

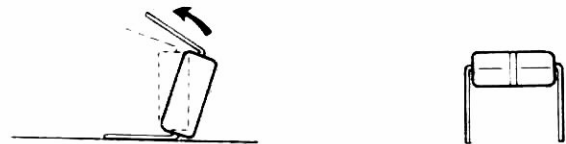

Detail 3-4A

START 

() Turn the circuit board over with the foil side up as shown.

() Cut the hooks from each end of the 25-pin and 3-pin sockets as shown. Then install the sockets on the foil side and solder the pins on the component side of the board. NOTE: The pin side of these sockets is **toward** the edge of the circuit board.

CUT OFF HOOKS

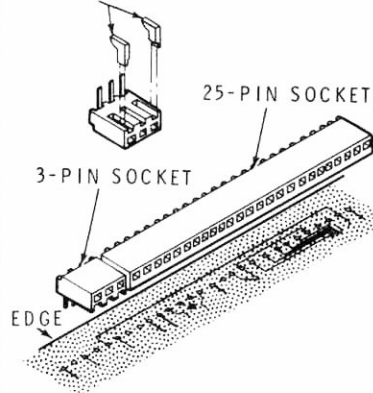

() Cut two 1/2" lengths of foam tape and peel off the backing. Install the tape on the back of the display tube at the approximate locations shown.

1/2" FOAM TAPE

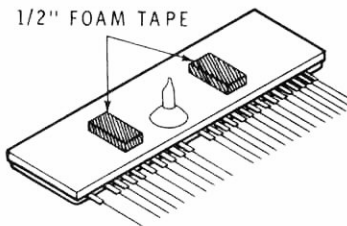

() Refer to Detail 3-5A (Illustration Booklet, Page 4) and insert the tube leads into the 25- and 3-pin sockets and the nipple on the back of the tube into the circuit board hole. Center the nipple in the hole.

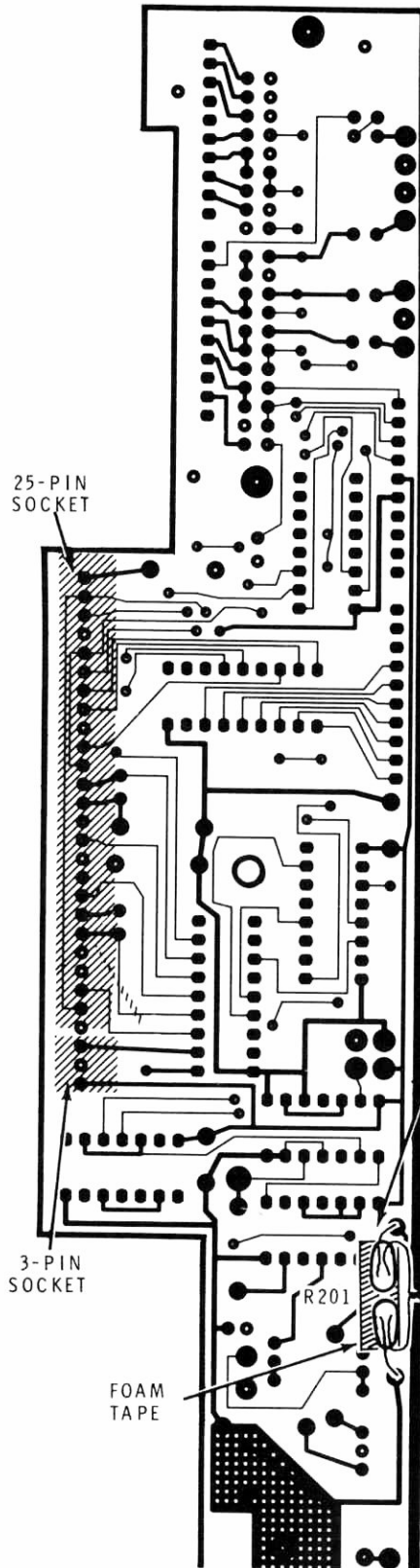

CONTINUE 

() Form a hook in the end of one of the leads from each lamp. Then connect the hooks together and solder them.

CONNECT HOOKS TOGETHER AND SOLDER

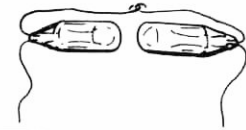

() Insert the lead of one lamp in hole A and the lead of the other lamp in hole B in the board. These holes are lettered on the component side of the board. Insert the leads so that the lamps are about 1/4" away from the board and solder the leads to the foil side of the circuit board. Cut off the excess lengths.

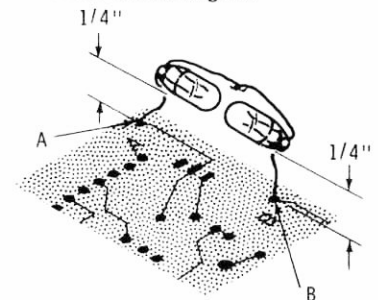

() Cut a 1/2" length of foam tape, remove the backing and place it over the foil pattern of plug P201.

() Position the lamps so they lay flat on the tape as shown below.

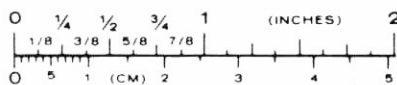
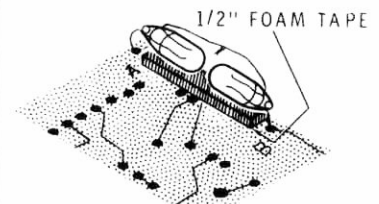

PICTORIAL 3-5

START 

() Turn the circuit board over with the component side up as shown.

As you install each control, solder the lugs and tabs to the foil and cut off the excess lug lengths.

() R201: Small 10 k Ω (#10-1138).

() R209: Large 10 k Ω (#10-148).

() R211: Large 10 k Ω (#10-148).

() R212: Large 10 k Ω (#10-148).

() R213: Large 10 k Ω (#10-148).

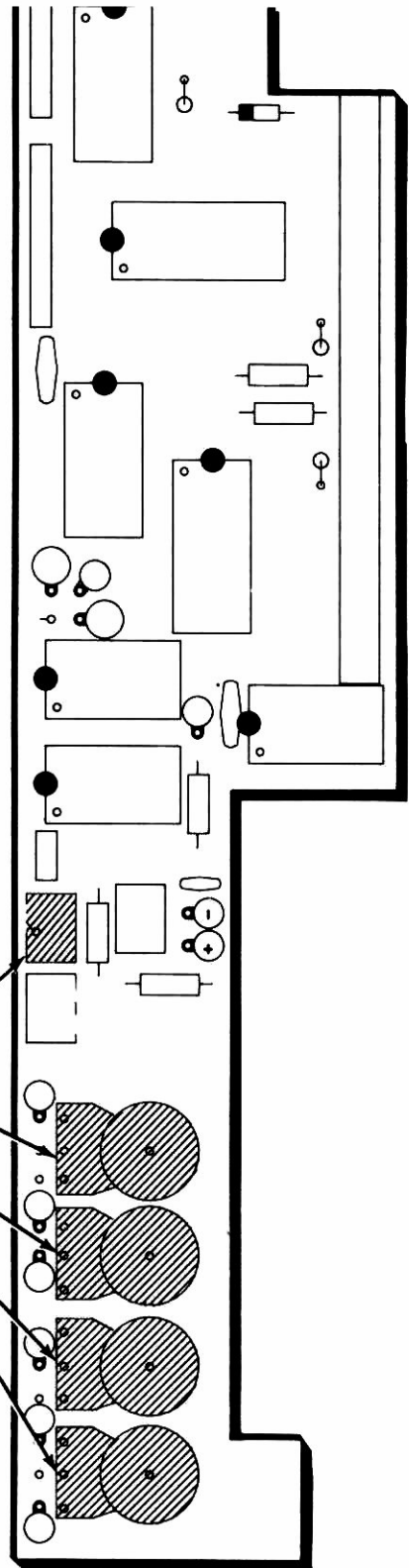

PICTORIAL 3-6

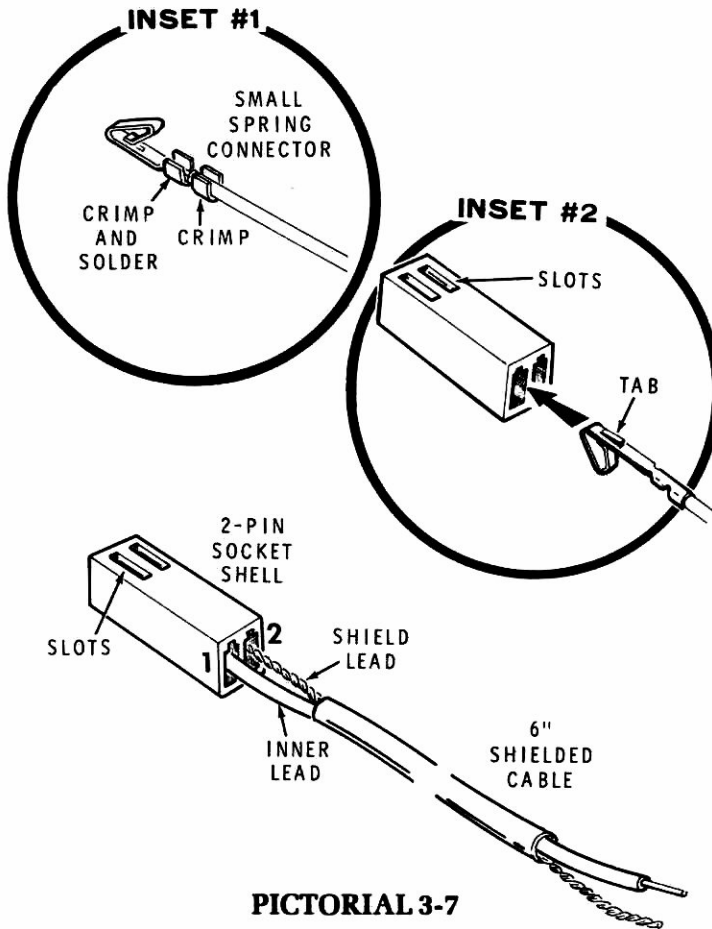

PICTORIAL 3-7

Refer to Pictorial 3-7 for the following steps.

- () Refer to Detail 3-7A and prepare two 6" black shielded cables as shown.

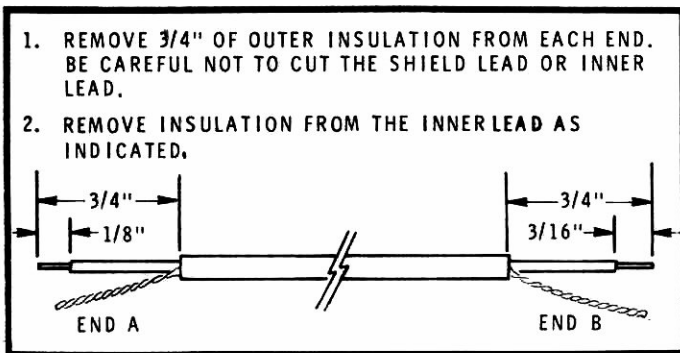

Detail 3-7A

- () Refer to inset drawing #1 on the Pictorial and install small spring connectors on both leads at end A of each cable. Use this same procedure whenever a step directs you to install a small spring connector. Use only enough solder to insure a good solder connection.

NOTE: In the following steps, you will insert the spring connectors, on the shielded cables, into 2-pin socket shells. Be sure to position the socket shells with the slotted side up and the connectors with the small tab up when you insert them. See inset drawing #2 on the Pictorial.

- () Push the spring connectors on one of the prepared shielded cables into a 2-pin socket shell as follows:

Inner lead into hole 1.

Shield lead into hole 2.

NOTE: Whenever you are directed to label a socket, carefully peel the corresponding label from the label sheet. Then press the label onto the side of the socket that is opposite to the slotted side. The hole numbers on the label must be toward the wire or lead end of the socket (see Detail 3-7B).

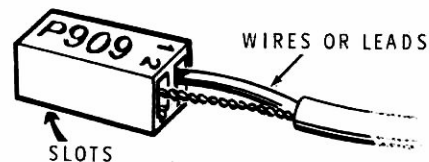

Detail 3-7B

- () Label this socket shell "P909". Then set this cable aside temporarily.

- () Push the spring connectors on the remaining prepared shielded cable into a 2-pin socket shell as follows:

Inner lead into hole 1.

Shield lead into hole 2.

- () Label this socket shell "P911". Then set this cable aside temporarily.

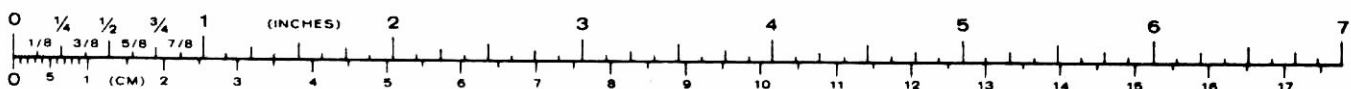

Heathkit®

Refer to Pictorial 3-8 (Illustration Booklet, Page 4) for the following steps.

NOTE: To prepare a wire, as in the next step, cut it to the indicated length and remove 1/4" of insulation from each end (unless the step directs you otherwise). If the wire is stranded, tightly twist each wire end and apply a small amount of solder to hold the fine strands together.

- () Prepare the following small stranded wires. Remove 3/16" of insulation from each end of these wires.

One 4" green

One 4" orange

Two 11" yellow

One 7-1/2" blue

One 5" violet

- () Shorten the bare portion at one end of the two prepared yellow wires to 1/8". Then install small spring connectors on this end of the yellow wires.
- () Refer to Detail 3-8A and insert the spring connector on one of the yellow wires into hole 1 of a 2-pin socket shell. Insert the spring connector on the remaining yellow wire into hole 2 of this socket shell.
- () Label this 2-pin socket shell "P904". Then loosely twist together (approximately 1 turn per inch) the two yellow wires coming from this socket shell.
- () Refer to inset drawing #1 on the Pictorial and install circuit board connectors on one end of the prepared green, orange, blue, and violet wires. Use this same procedure whenever a step directs you to install a circuit board connector.

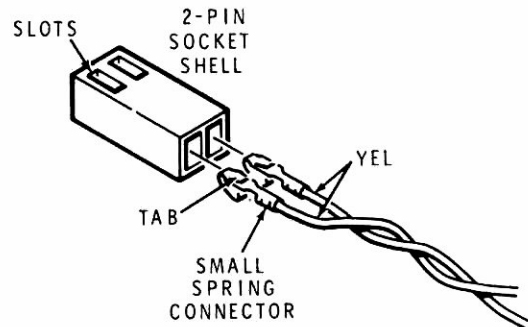

Detail 3-8A

- () Cut four 5/8" lengths of medium heat-shrinkable sleeving. Then use the following procedure to install the sleeving on each of the circuit board connectors that you installed on the wires in the previous step:

1. Push a length of sleeving onto the connector until it is flush with the end of the connector as shown in inset drawing #2 on the Pictorial.
2. Use the heat of a flame from a match, lighter, or candle to shrink the sleeving around the connector.

Set these prepared cables aside temporarily.

- () Locate the 3-1/2" 2-wire cable (brown and red wires) that you set aside earlier. Then refer to Detail 3-8B and prepare the ends of this cable as shown.

1. Separate the wires at each end of the cable for 3/4".
2. Remove 1/8" of insulation from the end of each wire and apply a small amount of solder.

- () Similarly, prepare the ends of two 5" 4-wire cables (brown, red, orange, and yellow wires) and one 5" 7-wire cable (black, white, gray, violet, blue, green, and yellow wires).

- () Install small spring connectors on one end of each of the prepared cables.

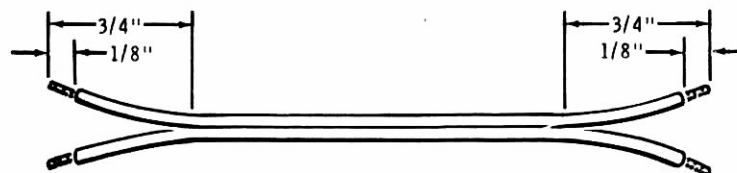

Detail 3-8B

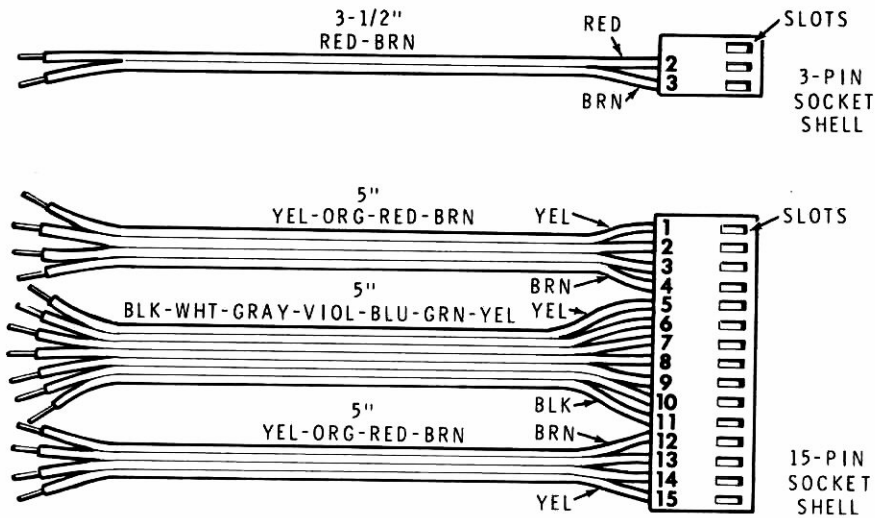

Detail 3-8C

Position a 3-pin socket shell as shown in Detail 3-8C. Then insert the spring connectors on the 3-1/2" cable into this socket shell as follows:

- () Red wire into hole 2.
- () Brown wire into hole 3.
- () Label this socket shell "P703". Then set this cable aside.

Position a 15-pin socket shell as shown in Detail 3-8C. Then insert the spring connectors on one of the yellow, orange, red, brown cables into this socket shell as follows:

- () Yellow wire into hole 1.
- () Orange wire into hole 2.
- () Red wire into hole 3.
- () Brown wire into hole 4.

Insert the spring connectors on the black, white, gray, violet, blue, green, yellow cable into the 15-pin socket shell as follows:

- () Yellow wire into hole 5.
- () Green wire into hole 6.
- () Blue wire into hole 7.

- () Violet wire into hole 8.

- () Gray wire into hole 9.

- () White wire into hole 10.

- () Black wire into hole 11.

Insert the spring connectors on the remaining yellow, orange, red, brown cable into the 15-pin socket shell as follows:

- () Brown wire into hole 12.

- () Red wire into hole 13.

- () Orange wire into hole 14.

- () Yellow wire into hole 15.

- () Label this 15-pin socket shell "P702".

Position the 15-pin socket shell as shown in the Pictorial. Then connect the free end of the black, white, gray, violet, blue, green, yellow cable coming from this socket shell to the holes at P202 on the display circuit board as follows. Solder each wire to the foil as you connect it and cut off any excess lead length.

- () Yellow wire to hole 1.

- () Green wire to hole 2.

Heathkit®

- () Blue wire to hole 3.
- () Violet wire to hole 4.
- () Gray wire to hole 5.
- () White wire to hole 6.
- () Black wire to hole 7.

Connect the yellow, orange, red, brown cable coming from holes 12-15 of the 15-pin socket shell to the holes at P203 of the display circuit board as follows. Solder each wire to the lead as you connect it and cut off any excess lead lengths.

- () Brown wire to hole 1.
- () Red wire to hole 2.
- () Orange wire to hole 3.
- () Yellow wire to hole 4.

Connect the brown, red, orange, yellow cable coming from holes 1-4 of the 15-pin socket shell to the holes at P203 of the display circuit board as follows. Solder each wire to the foil as you connect it and cut off any excess lead lengths.

NOTE: Be sure to skip holes 5 and 6 of P203 on the display circuit board.

- () Brown wire to hole 7.
- () Red wire to hole 8.
- () Orange wire to hole 9.
- () Yellow wire to hole 10.

Connect the free end of the wires coming from socket P703 to the holes at P203 of the display circuit board as follows. Solder each wire to the foil as you connect it and cut off any excess lead lengths.

- () Brown wire to hole 5.
- () Red wire to hole 6.

- () Prepare a 2" small brown and a 2" small red stranded wire. Use these wires in the next two steps.

NOTE: Solder each of the following wires to the foil as you connect it and cut off the excess lead lengths.

- () Connect one end of the 2" brown wire to the minus (-) hole in the display circuit board. The other end of this wire will be connected later.
- () Connect one end of the 2" red wire to the positive (+) hole in the display circuit board. The other end of this wire will be connected later.

- () Connect the free end of the shielded cable coming from socket P909 to the display circuit board as follows:

Inner lead to hole E.

Shield wires to hole G (do not solder this wire yet).

- () Connect the free end of the shielded cable coming from socket P911 to the display circuit board as follows:

Inner lead to hole F.

Shield wires to hole G (solder both wires).

- () Connect the free end of the green wire to display circuit board hole H.
- () Connect the free end of the orange wire to display circuit board hole J.
- () Connect the free end of one of the yellow wires coming from socket P904 to display circuit board hole K.
- () Connect the free end of the remaining yellow wire coming from socket P904 to display circuit board hole L.
- () Connect the free end of the blue wire to display circuit board hole M.
- () Connect the free end of the violet wire to display circuit board hole N.

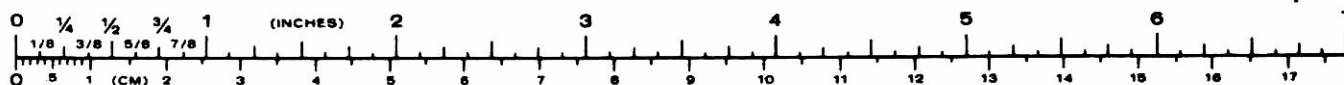

START ↓

NOTE: If you have purchased the Keypad Accessory, unpack the four diodes. Then return to this Pictorial and install them. If you did not purchase the accessory kit, disregard this Pictorial.

Install each of the following diodes with the banded end down over the circle on the circuit board.

() Turn the display circuit board over so the component side is up, as shown.

() D208: 1N191 (#56-26).

() D207: 1N191 (#56-26).

() D206: 1N191 (#56-26).

() D205: 1N191 (#56-26).

() Solder the leads to the foil and cut off the excess lead lengths.

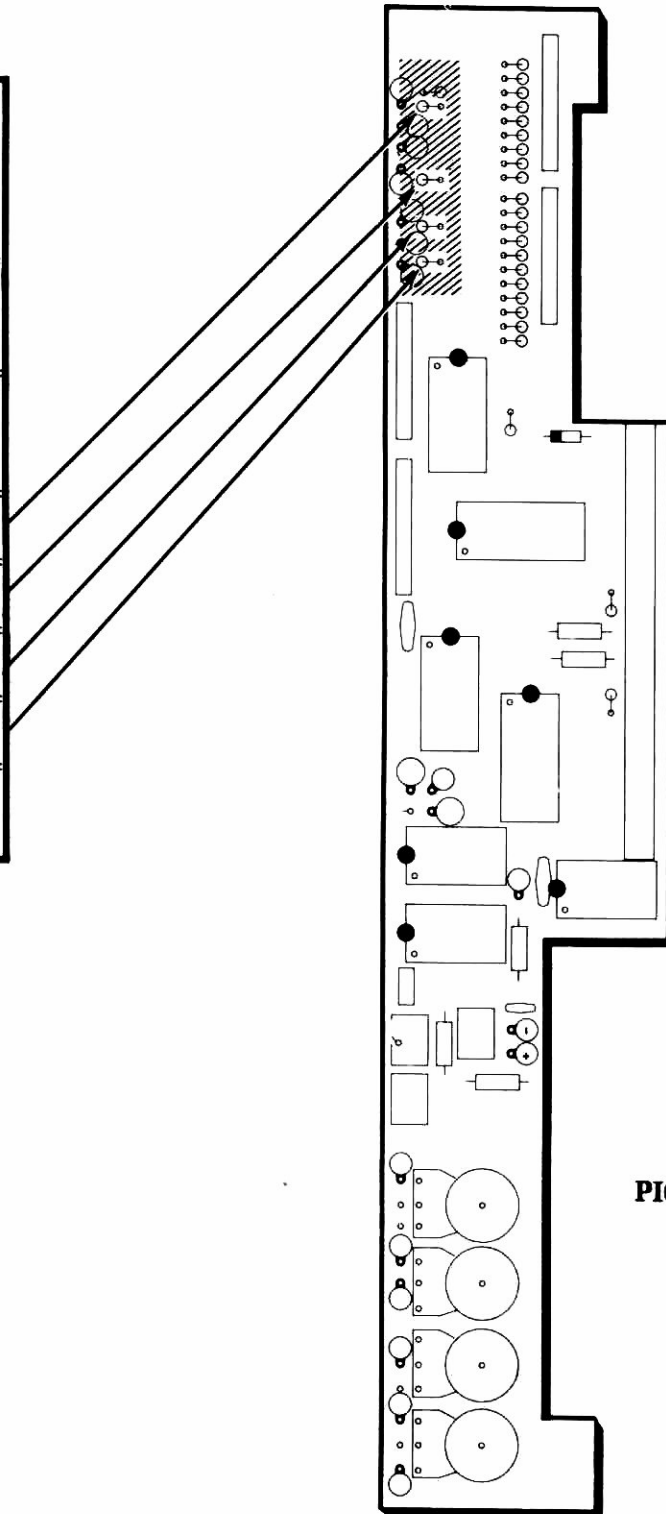

PICTORIAL 3-9

CIRCUIT BOARD CHECKOUT

Carefully inspect the circuit board for the following most commonly-made errors:

- () Unsoldered connection.
- () Poor solder connections.
- () Solder bridges between foil patterns.
- () Protruding leads which could touch together.
- () Diodes for the correct position of the banded end.
- () Integrated circuits for the improper type and installation.

INITIAL TESTS

NOTE: In the following steps, the setting of your ohmmeter is indicated in parentheses, "(R × 10K)" for example, because meaningful readings cannot be taken using a single range. Be sure to zero your ohmmeter each time you change ranges.

Refer to Pictorial 3-10 (Illustration Booklet, Page 5) for the following steps.

- () Connect the common ohmmeter lead to a ground point on the display circuit board foil. NOTE: A convenient point is the common foil that connects the four larger controls on the left side of the circuit board.

Use the positive ohmmeter probe to check the display circuit board plugs and pins for the following readings. Note that the steps are abbreviated like they were on the filter circuit board.

- () P201-1. Infinity. Check R201. (R × 1000).
- () P201-2. 10 Ω to 100 Ω. Check PL201, PL202. (R × 10).
- () P201-3. Infinity. Check U201, U202. (R × 10k).
- () Set the ohmmeter to R × 1000 for the following steps.
- () Circuit board pin C. 10 kΩ or greater. Check U205, U206.

Locate connector P703 coming from the circuit board. NOTE: You may have to wrap a length of small solid wire around your ohmmeter tip probe to take the following reading.

- () P703-2 (red wire). 5000 Ω or greater. Check U203 through U207.
- () P703-3 (brown wire). Zero ohms.

This completes the "Initial Tests" of your display circuit board. Disconnect your ohmmeter leads and set the circuit board aside until it is called for later during the assembly of the chassis. Proceed to "Audio Circuit Board."

AUDIO CIRCUIT BOARD

PARTS LIST

() Refer to the Pack Index Sheet and locate Pack #4. Then remove the parts from this pack and check each part against the following list. The key numbers correspond to the numbers on the "Audio Circuit Board Parts Pictorial" (Illustration Booklet, Page 5). Return any part that is packed in an individual envelope, with the part number on it, back into its envelope until that part is called for in a step. Do not throw away

any packing material until you account for all the parts.

To order a replacement part, always include the PART NUMBER. Use the Parts Order Form furnished with this kit. If a Parts Order Form is not available, refer to "Replacement Parts" inside the rear cover of this Manual. For prices, refer to the separate "Heath Parts Price List."

KEY No.	HEATH Part No.	QTY.	DESCRIPTION	CIRCUIT Comp No.
---------	----------------	------	-------------	------------------

RESISTORS

NOTES:

- Resistors may be packed in more than one envelope. Open all of the resistor envelopes in this pack before you check the resistors against the following Parts List.
- The following resistors are rated at 1/4-watt and have a tolerance of 5% (fourth band gold) unless otherwise noted.

A1	6-279-12	1	2.7 Ω (red-viol-gold)	R1043
A1	6-100-12	2	10 Ω (brn-blk-blk)	R983, R988
A1	6-330-12	1	33 Ω (org-org-blk)	R979
A1	6-470-12	1	47 Ω (yel-viol-blk)	R946
A1	6-510-12	2	51 Ω (gm-brn-blk)	R927, R993
A1	6-101-12	7	100 Ω (brn-blk-brn)	R934, R942, R996, R999, R1003, R1011, R1037
A1	6-221-12	2	220 Ω (red-red-brn)	R918, R1042
A1	6-271-12	3	270 Ω (red-viol-brn)	R989, R1012, R1036

KEY No.	HEATH Part No.	QTY.	DESCRIPTION	CIRCUIT Comp. No.
---------	----------------	------	-------------	-------------------

Resistors (Cont'd.)

A1	6-331-12	1	330 Ω (org-org-brn)	R924
A1	6-471-12	2	470 Ω (yel-viol-brn)	R982, R986
A1	6-561-12	1	560 Ω (gm-blu-brn)	R966
A1	6-681-12	1	680 Ω (blu-gry-brn)	R965
A1	6-821-12	2	820 Ω (gry-red-brn)	R926, R992
A1	6-102-12	15	1000 Ω (brn-blk-red)	R919, R923, R925, R928, R933, R936, R943, R969, R975, R991, R994, R995, R1002, R1024, R1026
A1	6-122-12	2	1200 Ω (brn-red-red)	R935, R997
A1	6-222-12	7	2200 Ω (red-red-red)	R945, R947, R948, R952, R967, R973, R985
A1	6-272-12	2	2700 Ω (red-viol-red)	R938, R998
A1	6-332-12	2	3300 Ω (org-org-red)	R984, R1022
A1	6-472-12	3	4700 Ω (yel-viol-red)	R917, R944, R951

Heathkit®

KEY No.	HEATH Part No.	QTY.	DESCRIPTION	CIRCUIT Comp. No.
Resistors (Cont'd.)				
A1	6-103-12	25	10 kΩ (brn-blk-org)	R901, R902, R912, R914, R916, R922, R937, R949, R964, R972, R974, R976, R977, R978, R981, R1001, R1005, R1008, R1013, R1014, R1023, R1025, R1034, R1035, R1041
A1	6-223-12	8	22 kΩ (red-red-org)	R909, R921, R929, R932, R939, R941, R987, R1021
A1	6-273-12	1	27 kΩ (red-viol-org)	R963
A1	6-333-12	3	33 kΩ (org-org-org)	R913, R1028, R1032
A1	6-473-12	1	47 kΩ (yel-viol-org)	R956
A1	6-563-12	1	56 kΩ (grn-blu-org)	R1007
A1	6-104-12	12	100 kΩ (brn-blk-yel)	R906, R915, R953, R957, R958, R959, R961, R968, R1017, R1019, R1038, R1039, R1004, R1006, R1009
A1	6-124-12	3	120 kΩ (brn-red-yel)	R905, R954, R1016, R1018, R1044
A1	6-154-12	5	150 kΩ (brn-grn-yel)	R1031
A1	6-334-12	1	330 kΩ (org-org-yel)	R904, R1027
A1	6-684-12	2	680 kΩ (blu-gry-yel)	R903, R907, R911, R955, R962
A1	6-105-12	5	1 MΩ (brn-blk-grn)	R908, R1029, R1033
A1	6-155-12	3	1.5 MΩ (brn-grn-grn)	
CAPACITORS				
Ceramic				
B1	21-7	1	33 pF	C926
B1	21-75	3	100 pF	C907, C932, C921

KEY No.	HEATH Part No.	QTY.	DESCRIPTION	CIRCUIT Comp. No.
Capacitors (Cont'd.)				
B1	21-22	4	220 pF	C966, C967, C971, C972
B1	21-23	1	420 pF	C906
B1	21-163	6	.001 μF (1000 pF)	C929, C977, C978, C979, C981, C986
B1	21-46	2	.005 μF	C963, C964
B1	21-176	11	.01 μF	C917, C918, C925, C931, C934, C942, C953, C957, C958, C1001, C1004
B1	21-143	6	.05 μF	C927, C933, C955, C987, C996, C998
B1	21-192	24	.1 μF (104M)	C902, C903, C904, C905, C908, C909, C912, C914, C922, C923, C935, C936, C938, C941, C945, C959, C961, C969, C973, C983, C988, C990, C992, C994
Electrolytic				
B2	25-900	1	1 μF	C982
B2	25-924	9	2.2 μF	C916, C943, C944, C947, C951, C965, C975, C985, C997
B2	25-925	3	4.7 μF	C915, C946, C949
B2	25-931	7	10 μF	C901, C924, C952, C962, C974, C995, C1002
B2	25-927	1	22 μF	C948
B2	25-928	3	33 μF	C913, C928, C999
B2	25-929	1	39 μF	C911
B2	25-920	1	68 μF	C956
B2	25-887	1	220 μF	C954
B2	25-905	3	470 μF	C989, C991, C993

KEY No.	HEATH Part No.	QTY.	DESCRIPTION	CIRCUIT Comp. No.
---------	----------------	------	-------------	-------------------

Capacitors (Cont'd.)**Mylar**

B3	27-63	1	.022 μ F	C937
----	-------	---	--------------	------

INDUCTORS

C1	45-51	1	10 μ H choke	L903
C2	45-98	1	Hash filter choke	L904
C3	45-604	2	100 μ H choke (brn-blk-brn)	L901, L902

DIODES

D1	56-26	4	1N191 (brn-wht-brn)	D905, D906, D907, D908
D1	57-65	1	1N4002	D913
D1	56-56	3	1N4149	D901, D911, D912
D1	56-58	2	1N5234B	D902, D909
D2	56-656	2	BA-379	D903, D904

TRANSISTORS — INTEGRATED CIRCUITS (ICs)

NOTE: Transistors and integrated circuits may be marked for identification in any of the following four ways:

1. Part number.
2. Type number. (On integrated circuits, this refers only to the numbers; the letters may be different or missing.)
3. Part number and type number.
4. Part number with a type number other than the one listed.

E1	417-852	3	TIP31 transistor	Q915, Q918, Q921
----	---------	---	------------------	---------------------

KEY No.	HEATH Part No.	QTY.	DESCRIPTION	CIRCUIT Comp. No.
---------	----------------	------	-------------	-------------------

Transistors — Integrated Circuits (ICs) (Cont'd.)

E2	417-864	11	MPSA05 transistor	Q902, Q903, Q908, Q909, Q913, Q914, Q917, Q922, Q923, Q924, Q925
E2	417-801	6	MPSA20 transistor	Q901, Q905, Q906, Q907, Q926, Q928
E2	417-865	4	MPSA55 transistor	Q911, Q912, Q916, Q919
E2	417-134	1	MPS6520 transistor	Q904
E2	417-201	1	X29A829 transistor	Q927
E3	442-602	2	LM324N IC	U901, U905
E4	442-96	2	MC1496G IC	U902, U904
E1	442-691	1	78M08 IC	U903

MISCELLANEOUS

F1	10-1137	1	2000 Ω (2 k Ω) control	R931
F1	10-1138	1	10 k Ω control	R971
	85-2682-1	1	Audio circuit board	
F2	215-89	4	Flat transistor heat sink	
F3	250-1411	4	4-40 \times 1/4" black phillips head screw	
F4	252-2	4	4-40 nut	
F5	254-34	4	#4 lockwasher	
F6	432-121	6	Circuit board pin (includes one extra)	
F7	432-866	6	Small spring connector (includes one extra)	
F8	432-969	10	5-pin plug	
F9	432-903	2	10-pin plug	
F10	432-970	1	5-pin socket shell	
F11	434-298	2	14-pin IC socket	
F12	475-10	3	Ferrite bead	

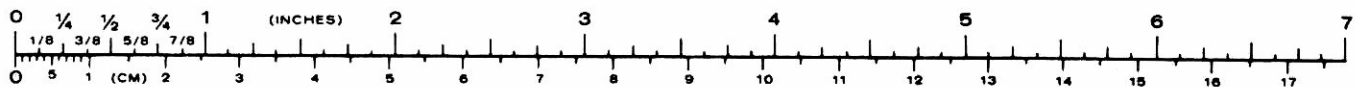

STEP-BY-STEP ASSEMBLY

The steps performed in this Pictorial are in this area of the circuit board.

START

Position the circuit board as shown. The Identification Drawing at the top of the page shows what area of the board you will be working with.

() R1042: 220Ω (red-red-brn).

() R1041: 10kΩ (brn-blk-org).

() R1038: 100kΩ (brn-blk-yel).

() R1039: 100kΩ (brn-blk-yel).

() R1043: 2.7Ω (red-viol-gld).

NOTE: Do not install a resistor at this location.

() R1012: 270Ω (red-viol-brn).

() R1013: 10kΩ (brn-blk-org).

() R1011: 100Ω (brn-blk-brn).

() Solder the leads to the foil and cut off the excess lead lengths.

() R1037: 100Ω (brn-blk-brn).

() R1028: 33kΩ (org-org-org).

() R1004: 120kΩ (brn-red-yel).

() R1027: 680kΩ (blu-gry-yel).

() R1002: 1000Ω (brn-blk-red).

() R991: 1000Ω (brn-blk-red).

() R998: 2700Ω (red-viol-red).

() R992: 820Ω (gry-red-brn).

() R999: 100Ω (brn-blk-brn).

() Solder the leads to the foil and cut off the excess lead lengths.

PART NUMBER

IDENTIFICATION DRAWING

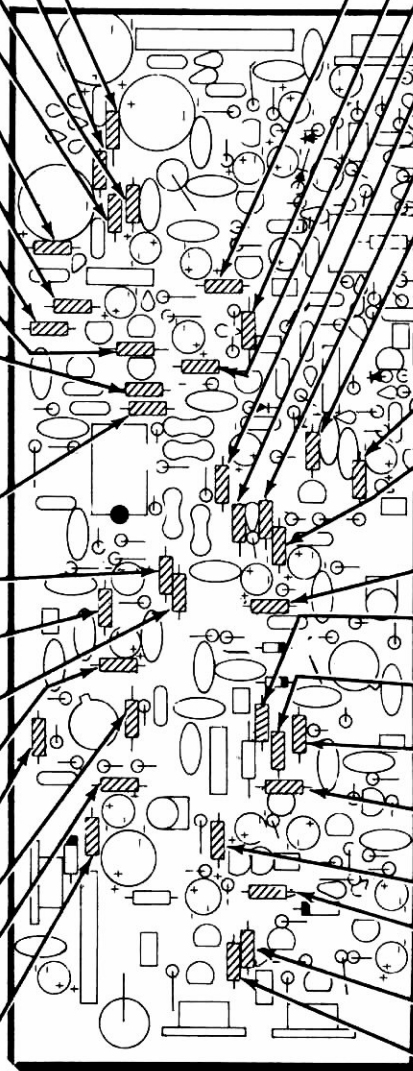

PICTORIAL 4-1

CONTINUE

() R1034: 10kΩ (brn-blk-org).

() R1025: 10kΩ (brn-blk-org).

() R1014: 10kΩ (brn-blk-org).

() R1032: 33kΩ (org-org-org).

() R1003: 100Ω (brn-blk-brn).

() R952: 2200Ω (red-red-red).

() R944: 4700Ω (yel-viol-red).

NOTE: When you install the 100 μH Chokes (#45-604), on this circuit board and on many other circuit boards, do not put excess stress on the leads. To do so could cause an intermittent inside the choke.

() L901: 100 μH choke, (#45-604 brn-blk-brn).

() R926: 820Ω (gry-red-brn).

() Solder the leads to the foil and cut off the excess lead lengths.

() R934: 100Ω (brn-blk-brn).

() R946: 47Ω (yel-viol-blk).

() R972: 10kΩ (brn-blk-org).

() R945: 2200Ω (red-red-red).

() R949: 10kΩ (brn-blk-org).

() R977: 10kΩ (brn-blk-org).

() R975: 1000Ω (brn-blk-red).

() R987: 22kΩ (red-red-org).

() R986: 470Ω (yel-viol-brn).

() Solder the leads to the foil and cut off the excess lead lengths.

The steps performed in this Pictorial are in this area of the circuit board.

START ↘

NOTE: DIODES MAY BE SUPPLIED IN ANY OF THE FOLLOWING SHAPES. ALWAYS POSITION THE BANDED END AS SHOWN ON THE CIRCUIT BOARD.

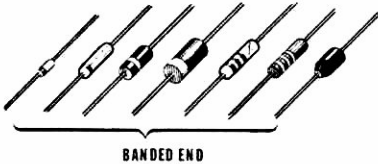

PART NUMBER

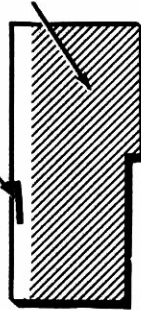

IDENTIFICATION DRAWING

NOTE: When you install a vertically mounted diode, position the banded end UP and the body of the diode over the larger circle on the board.



() D907: 1N191 (brn-wht-brn), #56-26.

() D908: 1N191 (brn-wht-brn), #56-26.

() D901: 1N4149 (#56-56).

() D905: 1N191 (brn-wht-brn), #56-26.

() D906: 1N191 (brn-wht-brn), #56-26.

() D902: 1N5234B (#56-58).

NOTE: The following diodes are horizontally mounted. Be sure to match the banded end with the band on the board.

() D913: 1N4002 (#57-65).

() D909: 1N5234B (#56-58).

() Solder the leads to the foil and cut off the excess lead lengths.

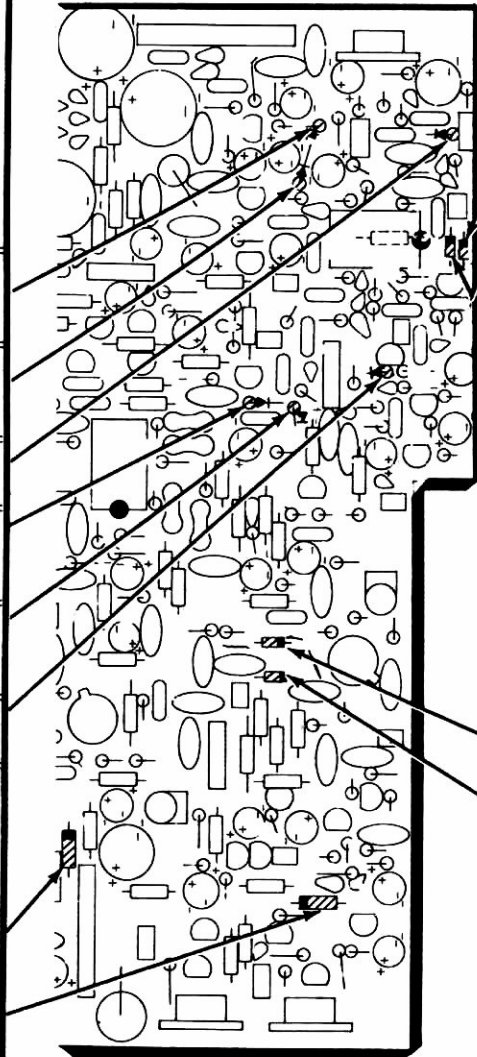

CONTINUE ↘

() D912: 1N4149 (#56-56).

() D911: 1N4149 (#56-56).

NOTE: When you install each of the next two diodes, match the marked end with the band on the board.

MARKED END



OR

RIDGE

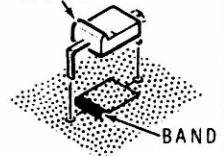

() D904: BA-379 (#56-656).

() D903: BA-379 (#56-656).

() Solder the leads to the foil and cut off the excess lead lengths.

PICTORIAL 4-2

The steps performed in this Pictorial are in this area of the circuit board.

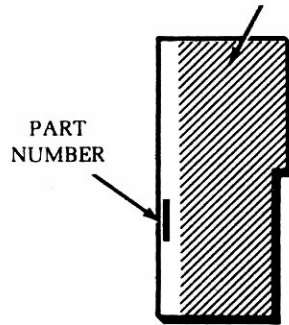

IDENTIFICATION DRAWING

START ▾

NOTE: You will install IC sockets in the following steps. Be sure the socket pins are straight. Insert the socket pins into the holes. The index mark on the circuit board must still be visible after it is installed. Solder the pins to the foil as you install each socket and cut off any excess pin lengths.

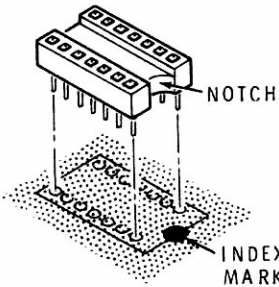

() 14-pin IC socket at U901.

() 14-pin IC socket at U905.

Install the following controls, solder the leads to the foil and cut off the excess lead lengths.

() R931: 2000Ω (2kΩ) #10-1137.

() R971: 10kΩ (#10-1138).

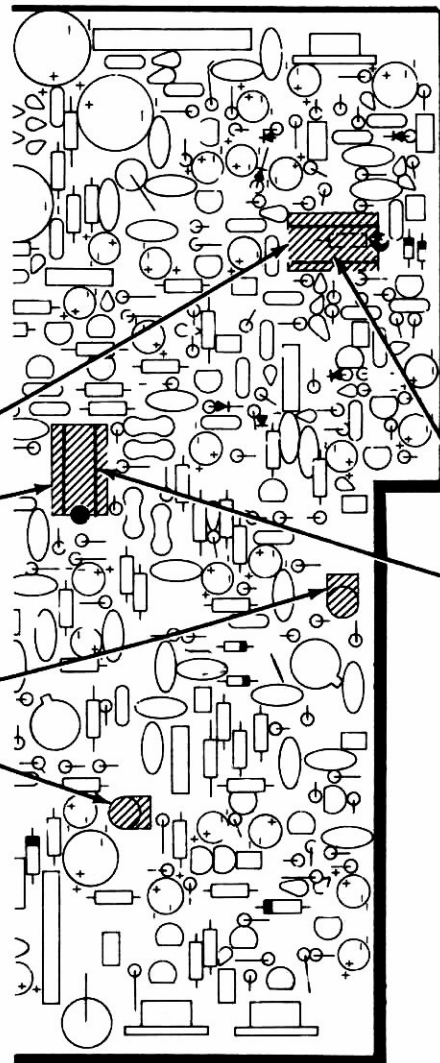

CONTINUE ▾

Refer to "Integrated Circuit Installation" on Page 35 and then install the IC's in the following steps.

() U901: LM324N (#442-602).

() U905: LM324N (#442-602).

PICTORIAL 4-3

The steps performed in this Pictorial are in this area of the circuit board.

START →

NOTE: When you are instructed to install circuit board pins, install them as shown and solder them to the foil.

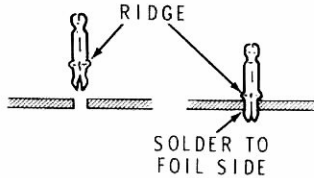

() Circuit board pin at J.

() Circuit board pin at K.

() C992: .1μF (104M) ceramic.

() C988: .1μF (104M) ceramic.

() Circuit board pin at L.

() C990: .1μF (104M) ceramic.

() C973: .1μF (104M) ceramic.

() C983: .1μF (104M) ceramic.

() C969: .1μF (104M) ceramic.

() 3/4" Small bare wire.

() 3/4" Small bare wire.

() C959: .1μF (104M) ceramic.

() C961: .1μF (104M) ceramic.

NOTE: Install the ferrite beads as shown. Use 1" lengths of small bare wire.

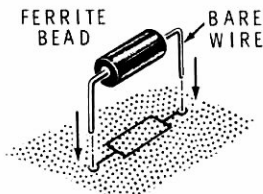

() Ferrite bead.

() Ferrite bead.

() Solder the leads to the foil and cut off the excess lead lengths.

PART NUMBER

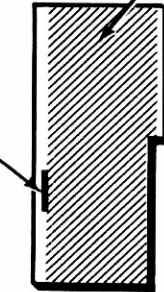

IDENTIFICATION DRAWING

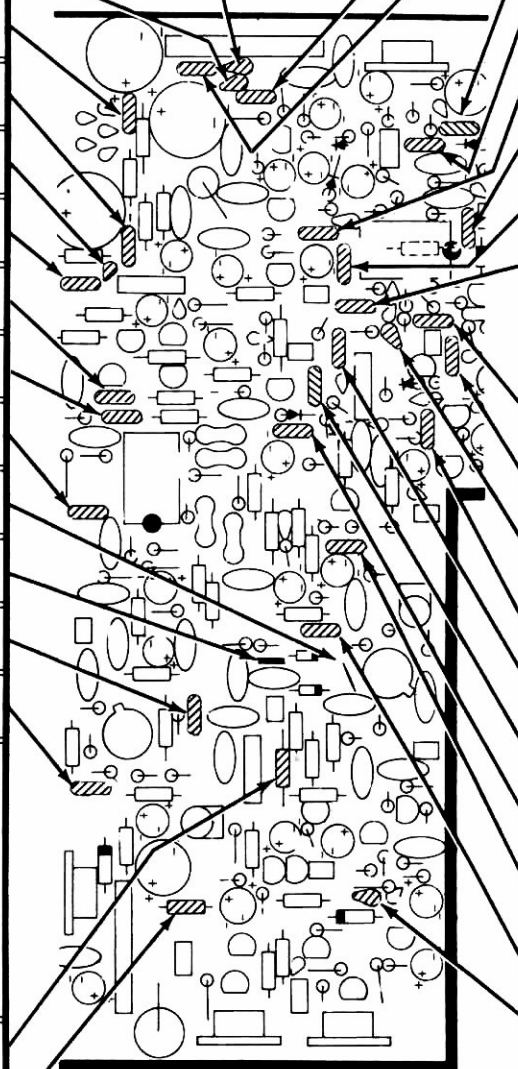

PICTORIAL 4-4

CONTINUE →

() C941: .1μF (104M) ceramic.

() C994: .1μF (104M) ceramic.

() C905: .1μF (104M) ceramic.

() C908: .1μF (104M) ceramic.

() C945: .1μF (104M) ceramic.

() C909: .1μF (104M) ceramic.

() C902: .1μF (104M) ceramic.

() C903: .1μF (104M) ceramic.

() Solder the leads to the foil and cut off the excess lead lengths.

() C938: .1μF (104M) ceramic.

() C912: .1μF (104M) ceramic.

() Circuit board pin at I.

() C914: .1μF (104M) ceramic.

() C904: .1μF (104M) ceramic.

() C935: .1μF (104M) ceramic.

() C936: .1μF (104M) ceramic.

() C923: .1μF (104M) ceramic.

() C922: .1μF (104M) ceramic.

() Circuit board pin at M.

() Solder the leads to the foil and cut off the excess lead lengths.

START

NOTE: Mount the following resistors vertically (similar to the way you mounted the diodes earlier).

- () R964: 10kΩ (brn-blk-org).
- () R1021: 22kΩ (red-red-org).
- () R1022: 3300Ω (org-org-red).
- () R1023: 10kΩ (brn-blk-org).
- () R1024: 1000Ω (brn-blk-red).
- () R1026: 1000Ω (brn-blk-red).
- () R1035: 10kΩ (brn-blk-org).
- () R1036: 270Ω (red-viol-brn).
- () R1009: 120kΩ (brn-red-yel).
- () R1008: 10kΩ (brn-blk-org).
- () Solder the leads to the foil and cut off the excess lead lengths.
- () R1007: 56kΩ (grn-blu-org).
- () R1018: 150kΩ (brn-grn-yel).
- () R1006: 120kΩ (brn-red-yel).
- () R1016: 150kΩ (brn-grn-yel).
- () R1005: 10kΩ (brn-blk-org).
- () R1017: 100kΩ (brn-blk-yel).
- () R994: 1000Ω (brn-blk-red).
- () R996: 100 Ω (brn-blk-brn).
NOTE: Your circuit board may be marked 330.
- () R995: 1000 Ω (brn-blk-red).
- () R1001: 10kΩ (brn-blk-org).
- () R997: 1200Ω (brn-red-red).
- () Solder the leads to the foil and cut off the excess lead lengths.

IDENTIFICATION DRAWING

PART NUMBER

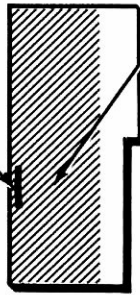

The steps performed in this Pictorial are in this area of the circuit board.

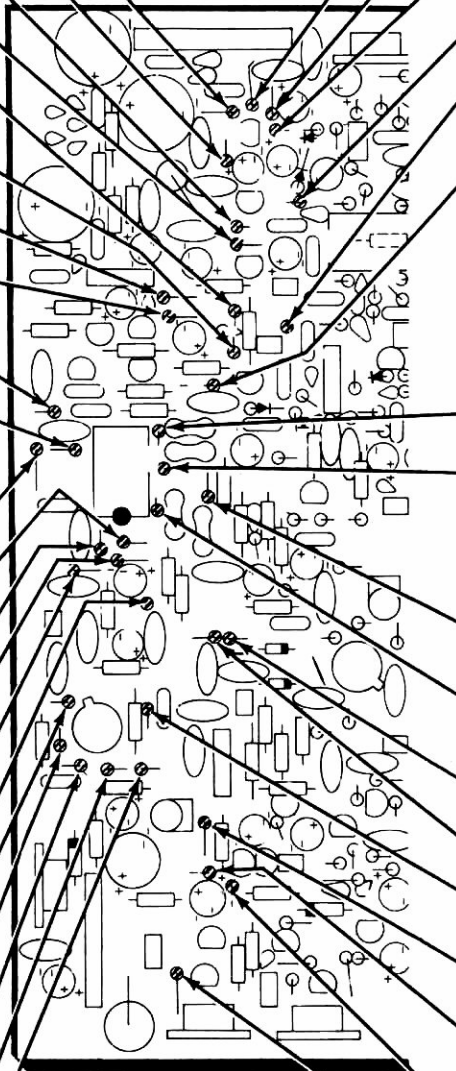

PICTORIAL 4-5



CONTINUE

- () R965: 680 Ω (blu-gry-brn).
- () R963: 27kΩ (red-viol-org).
- () R966: 560Ω (grn-blu-brn).
- () R968: 100kΩ (brn-blk-yel).
- () R905: 150kΩ (brn-grn-yel).
- () Ferrite bead. Use a 1" length of bare wire and install the bead as shown.

- () R1033: 1.5MΩ (brn-grn-grn).
- () R1019: 100kΩ (brn-blk-yel).
- () Solder the leads to the foil and cut off the excess lead lengths.
- () R1031: 330kΩ (org-org-yel).
- () R1029: 1.5MΩ (brn-grn-grn).
- () R948: 2200Ω (red-red-red).
- () R947: 2200Ω (red-red-red).
- () R993: 51Ω (grn-brn-blk).
- () R969: 1000Ω (brn-blk-red).
- () R976: 10kΩ (brn-blk-org).
- () R974: 10kΩ (brn-blk-org).
- () R988: 10Ω (brn-blk-blk).
- () Solder the leads to the foil and cut off the excess lead lengths.

The steps performed in this Pictorial are in this area of the circuit board.

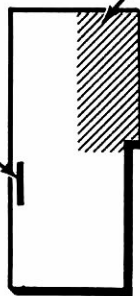
PART NUMBER



IDENTIFICATION DRAWING

START →

- () R914: 10kΩ (brn-blk-org).
- () R916: 10kΩ (brn-blk-org).
- () R901: 10kΩ (brn-blk-org).
- () R902: 10kΩ (brn-blk-org).
- () R903: 1MΩ (brn-blk-grn).
- () R904: 680kΩ (blu-gry-yel).
- () R908: 1.5MΩ (brn-grn-grn).
- () Solder the leads to the foil and cut off the excess lead lengths.
- () R959: 100kΩ (brn-blk-yel).
- () R962: 1MΩ (brn-blk-grn).
- () R906: 100kΩ (brn-blk-yel).
- () R958: 100kΩ (brn-blk-yel).
- () R917: 4700Ω (yel-viol-red).
- () R953: 100kΩ (brn-blk-yel).
- () R921: 22kΩ (red-red-org).
- () R923: 1000Ω (brn-blk-red).
- () Solder the leads to the foil and cut off the excess lead lengths.

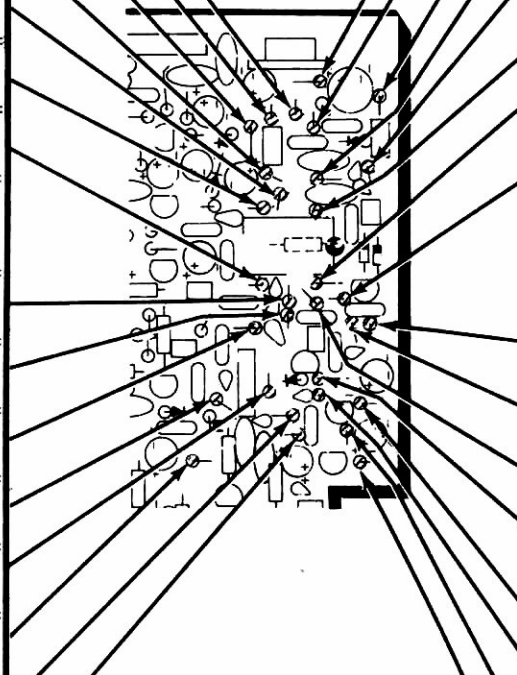

PICTORIAL 4-6

CONTINUE ↘

- () R989: 270Ω (red-viol-brn).
- () R911: 1MΩ (brn-blk-grn).
- () R909: 22kΩ (red-red-org).
- () R912: 10kΩ (brn-blk-org).
- () R907: 1MΩ (brn-blk-grn).
- () R913: 33kΩ (org-org-org).
- () R957: 100kΩ (brn-blk-yel).
- () R956: 47kΩ (yel-viol-org).
- () Solder the leads to the foil and cut off the excess lead lengths.
- () R954: 150kΩ (brn-grn-yel).
- () R955: 1MΩ (brn-blk-grn).
- () R961: 100kΩ (brn-blk-yel).
- () R918: 220Ω (red-red-brn).
- () R919: 1000Ω (brn-blk-red).
- () R922: 10kΩ (brn-blk-org).
- () R1044: 150kΩ (brn-grn-yel).
- () R924: 330Ω (org-org-brn).
- () Solder the leads to the foil and cut off the excess lead lengths.

IDENTIFICATION
DRAWING

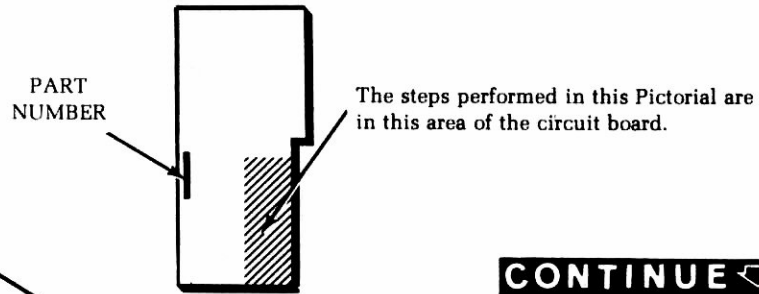

START ▾

- () R933: 1000Ω (brn-blk-red).
- () R925: 1000Ω (brn-blk-red).
- () R967: 2200Ω (red-red-red).
- () R935: 1200Ω (brn-red-red).
- () R937: 10kΩ (brn-blk-org).
- () R938: 2700Ω (red-viol-red).
- () R973: 2200Ω (red-red-red).
- () Solder the leads to the foil and cut off the excess lead lengths.
- () R951: 4700Ω (yel-viol-red).
- () R985: 2200Ω (red-red-red).
- () R984: 3300 Ω (org-org-red).
NOTE: You may have to scrape the solder resist from the foil pads for this resistor to make soldering easier.
- () R981: 10kΩ (brn-blk-org).
- () R982: 470Ω (yel-viol-brn).
- () R983: 10Ω (brn-blk-blk).
- () Solder the leads to the foil and cut off the excess lead lengths.

CONTINUE ▾

- () R928: 1000Ω (brn-blk-red).
- () R932: 22 kΩ (red-red-org).
- () R936: 1000Ω (brn-blk-red).
- () R929: 22kΩ (red-red-org).
- () R927: 51Ω (grn-brn-blk).
- () R942: 100Ω (brn-blk-brn).
- () Solder the leads to the foil and cut off the excess lead lengths.
- () R939: 22kΩ (red-red-org).
- () R991: 22kΩ (red-red-org).
- () L902: 100μH choke (brn-blk-brn), #45-604.
- () R943: 1000Ω (brn-blk-red).
- () R979: 33Ω (org-org-blk).
- () R978: 10kΩ (brn-blk-org).
- () Solder the leads to the foil and cut off the excess lead lengths.

PICTORIAL 4-7

IDENTIFICATION
DRAWING



The steps performed in this Pictorial are in this area of the circuit board.

START ↘

- () Locate seven 5-pin plugs. Make four 3-pin and ten 2-pin plugs by cutting through the case between the lugs as shown.

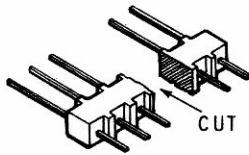

To install the plugs, insert the short pins into the circuit board and solder them to the foil.

- () 2-pin plug and 10-pin plug at P914.
- () 5-pin plug at P912.
- () 2-pin plug at P911.
- () 2-pin plug at P909.
- () 5-pin plug at P908.
- () 2-pin plug at P907.
- () 2-pin plug at P919.
- () 2-pin plug at P918.
- () 5-pin plug at P905.
- () 10-pin plug at P901.

CONTINUE ↘

- () 3-pin plug at P913.
- () 3-pin plug at P915.
- () 2-pin plug at P916.
- () 2-pin plug at P917.

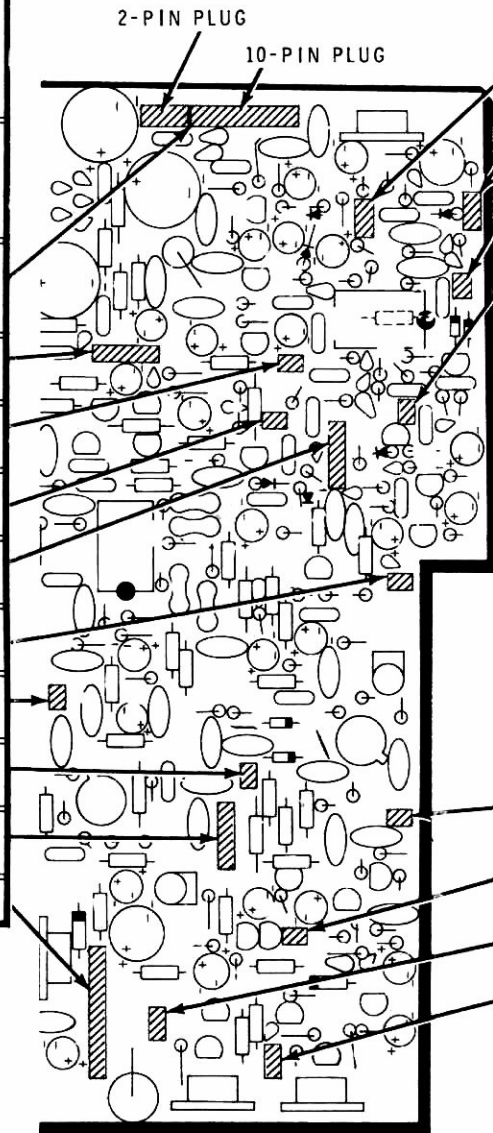

- () 2-pin plug at P906.
- () 2-pin plug at P904.
- () 3-pin plug at P902.
- () 3-pin plug at P903.

PICTORIAL 4-8

START

NOTE: When you install each of the following transistors, position the flat on the transistor over the outline of the flat on the circuit board. Then insert the leads into the circuit board holes and solder them to the foil. Cut off the excess lead lengths.

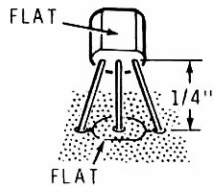

- () Q924: MPSA05 (#417-864).
- () Q925: MPSA05 (#417-864).
- () Q923: MPSA05 (#417-864).
- () Q922: MPSA05 (#417-864).

NOTE: To install the next two IC's, line up the tab on the IC with the outline of the tab on the circuit board. Then insert the leads in their respective holes in the board. Solder the leads to the foil and cut off the excess lead lengths.

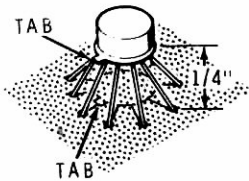

- () U904: MC1496G (#442-96).
- () U902: MC1496G (#442-96).
- () Q912: MPSA55 (#417-865).
- () Q917: MPSA05 (#417-864).
- () Q919: MPSA55 (#417-865).

PART NUMBER

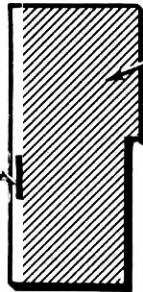

IDENTIFICATION DRAWING

The steps performed in this Pictorial are in this area of the circuit board.

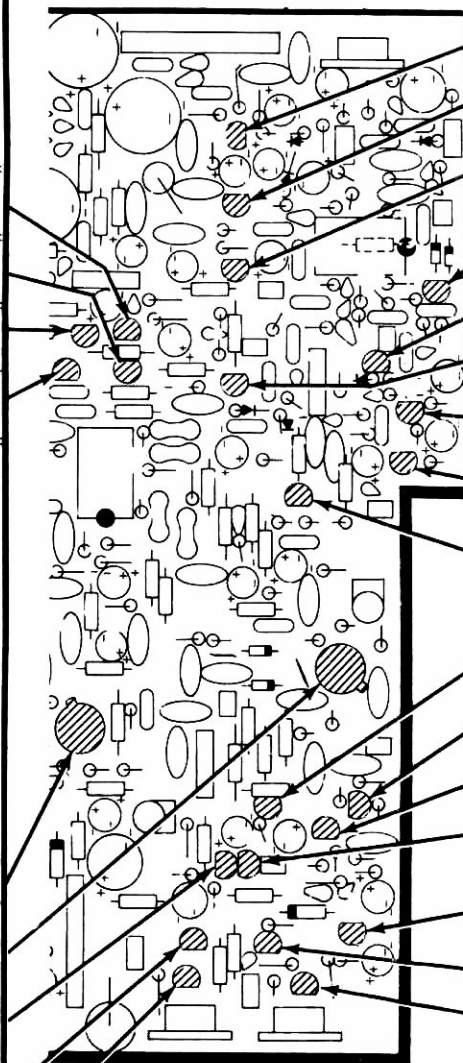

PICTORIAL 4-9

CONTINUE

- () Q908: MPSA05 (#417-864).
- () Q926: MPSA20 (#417-801).
- () Q927: X29A829 (#417-201).
- () Q907: MPSA20 (#417-801).
- () Q901: MPSA20 (#417-801).
- () Q928: MPSA20 (#417-801).
- () Q902: MPSA05 (#417-864).
- () Q903: MPSA05 (#417-864).
- () Q905: MPSA20 (#417-801).
- () Q909: MPSA05 (#417-864).
- () Q904: MPS6520 (#417-134).
- () Q906: MPSA20 (#417-801).
- () Q911: MPSA55 (#417-865).
- () Q913: MPSA05 (#417-864).
- () Q914: MPSA05 (#417-864).
- () Q916: MPSA55 (#417-865).

IDENTIFICATION
DRAWING

The steps performed in this Pictorial are in this area of the circuit board.

PART
NUMBER

START ↘

NOTE: When you install electrolytic capacitors, always match the positive (+) mark on the capacitor with the positive (+) mark on the circuit board OR match the negative (-) mark on the capacitor with the negative (-) mark on the circuit board.

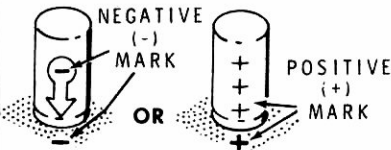

CONTINUE ↘

- () C985: 2.2 μ F electrolytic.
- () C975: 2.2 μ F electrolytic.
- () C971: 220 pF ceramic.
- () C972: 220 pF ceramic.
- () C967: 220 pF ceramic.
- () C1002: 10 μ F electrolytic.
- () C966: 220 pF ceramic.
- () Solder the leads to the foil and cut off the excess lead lengths.
- () C963: .005 μ F ceramic.
- () C958: .01 μ F ceramic.
- () C965: 2.2 μ F electrolytic.
- () C962: 10 μ F electrolytic.
- () C954: 220 μ F electrolytic.
- () C953: .01 μ F ceramic
- () C952: 10 μ F electrolytic.
- () Solder the leads to the foil and cut off the excess lead lengths.

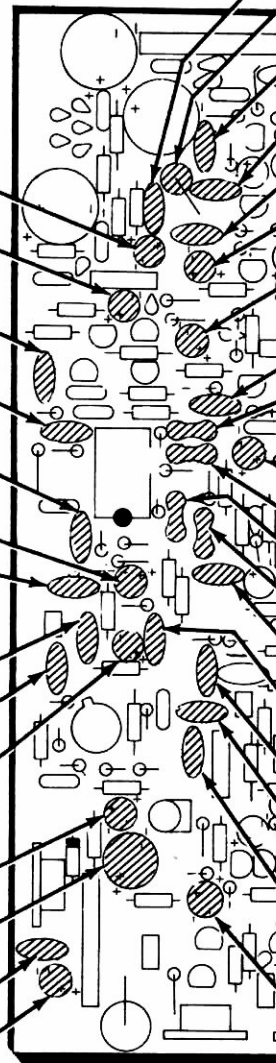

- () C986: .001 μ F (1000 pF) ceramic.
- () L903: 10 μ H choke (#45-51).
- () C987: .05 μ F ceramic.
- () C998: .05 μ F ceramic.
- () C996: .05 μ F ceramic.
- () C982: 1 μ F electrolytic.
- () C974: 10 μ F electrolytic.
- () C1001: .01 μ F ceramic.
- () C981: .001 μ F (1000 pF) ceramic.
- () Solder the leads to the foil and cut off the excess lead lengths.
- () C995: 10 μ F electrolytic.
- () C979: .001 μ F (1000 pF) ceramic.
- () C977: .001 μ F (1000 pF) ceramic.
- () C978: .001 μ F (1000 pF) ceramic.
- () C1004: .01 μ F ceramic.
- () C964: .005 μ F ceramic.
- () C932: 100 pF ceramic.
- () C957: .01 μ F ceramic.
- () C933: .05 μ F ceramic.
- () C949: 4.7 μ F electrolytic.
- () Solder the leads to the foil and cut off the excess lead lengths.

PICTORIAL 4-10

IDENTIFICATION
DRAWING

PART
NUMBER



The steps performed in this Pictorial are
in this area of the circuit board.

START ↘

- C955: .05μF ceramic.
- C942: .01μF ceramic.
- C944: 2.2μF electrolytic.
- C997: 2.2μF electrolytic.
- C943: 2.2μF electrolytic.
- C901: 10μF electrolytic.
- C999: 33μF electrolytic.
- Solder the leads to the foil and cut off the excess lead lengths.
- C931: .01μF ceramic.
- C917: .01μF ceramic.
- C924: 10μF electrolytic.
- C946: 4.7μF electrolytic.
- C925: .01μF ceramic.
- C934: .01μF ceramic.
- C921: 100pF ceramic.
- C926: 33pF ceramic.
- C947: 2.2μF electrolytic.
- C948: 22 μF electrolytic.
- Solder the leads to the foil and cut off the excess lead lengths.

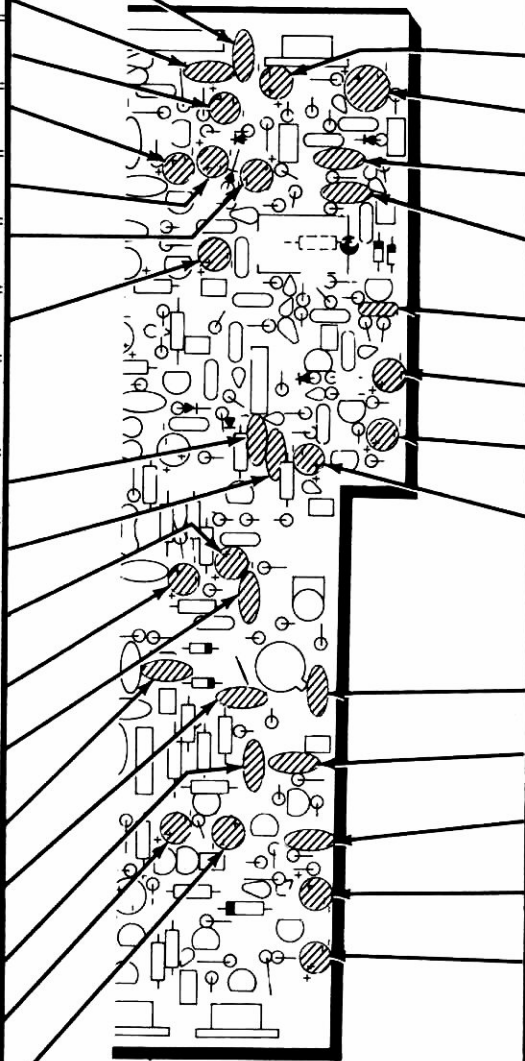

CONTINUE ↘

- C911: 39μF electrolytic.
- C956: 68μF electrolytic.
- C906: 420 pF ceramic.
- C907: 100 pF ceramic.
- C937: .022μF mylar.
- C913: 33μF electrolytic.
- C915: 4.7μF electrolytic.
- C916: 2.2μF electrolytic.
- Solder the leads to the foil and cut off the excess lead lengths.
- C918: .01μF ceramic.
- C929: .001μF (1000 pF) ceramic.
- C927: .05μF ceramic.
- C928: 33μF electrolytic.
- C951: 2.2μF electrolytic.
- Solder the leads to the foil and cut off the excess lead lengths.

PICTORIAL 4-11

IDENTIFICATION
DRAWING

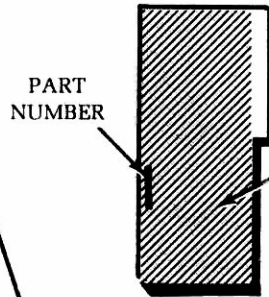

The steps performed in this Pictorial are in this area of the circuit board.

START ↘

- () C993: 470 μ F electrolytic.
 - () C989: 470 μ F electrolytic.
 - () C991: 470 μ F electrolytic.
 - () Solder the leads to the foil and cut off the excess lead lengths.
 - () Position the flat transistor heat sinks as shown. Mount TIP31 (#417-852) transistors on three of them, and mount a 78M08 (#442-691) IC on the other one. Use 4-40 \times 1/4" black phillips head screws, #4 lockwashers, and 4-40 nuts.
- 4-40 x 1/4" BLACK PHILLIPS HEAD SCREW

TIP31 (#417-852)

FLAT TRANSISTOR HEAT SINK

TAB

#4 LOCKWASHER

4-40 NUT
- () Install the three TIP31 transistor-heat sink assemblies at Q915, Q918, and Q921. Insert the transistor leads into their respective holes and the heat sink tab into the larger hole. Solder the leads and tabs to the foil and cut off the excess lead lengths.
 - () Similarly install the 78M08 IC-heat sink assembly at U903.

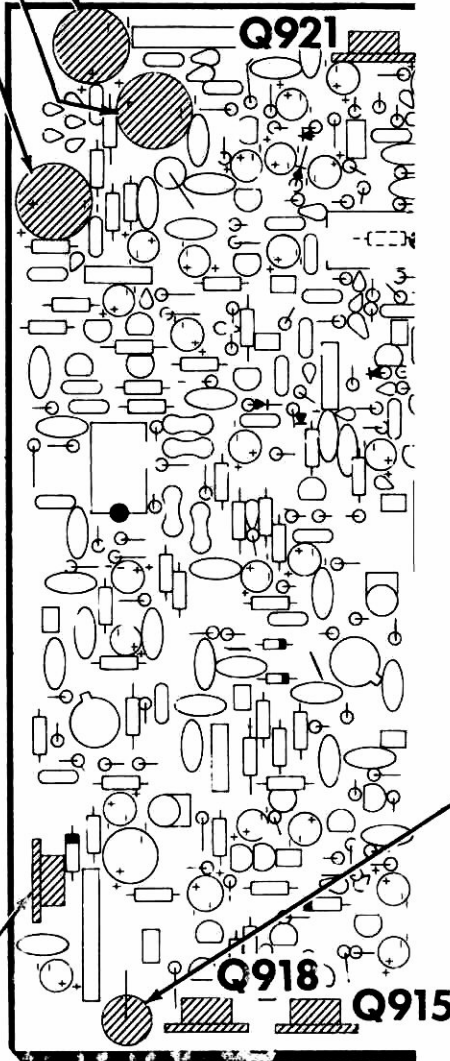

CONTINUE ↘

- () L904: Hash filter choke (#45-98). Solder the leads to the foil and cut off the excess lead lengths.

PICTORIAL 4-12

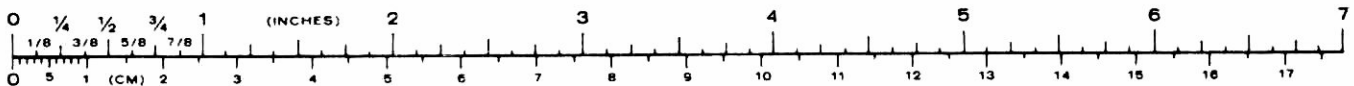

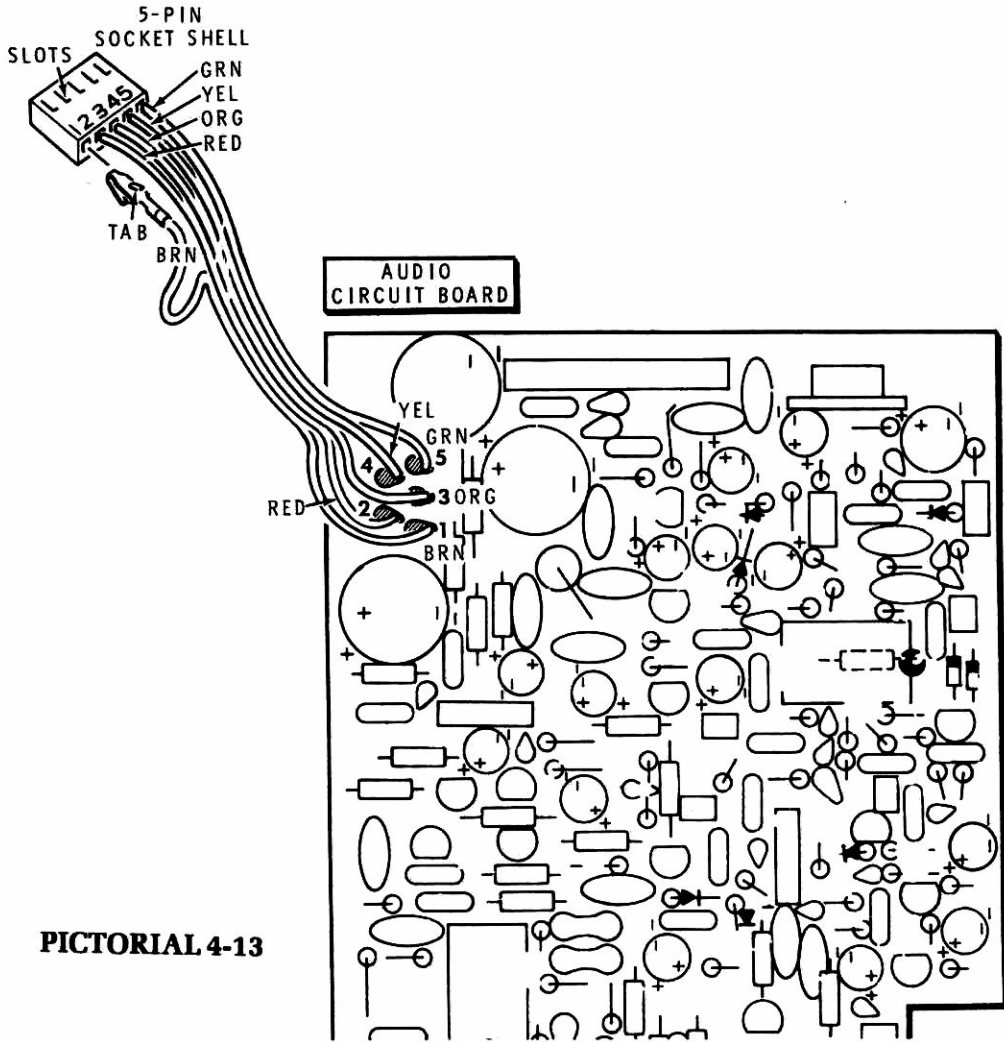

PICTORIAL 4-13

Refer to Pictorial 4-13 for the following steps.

- () Locate the 4" 5-wire cable (brown, red, orange, yellow, and green wires) set aside earlier.
- () Separate the wires of this 4" cable for 3/4" at each end. Remove 1/8" of insulation from one end of this cable and 1/4" of insulation from the other end. Then prepare the ends.
- () Install small spring connectors on each wire at one end of the prepared cable (where you removed 1/8" of insulation).

Insert the spring connectors on the prepared cable into a 5-pin socket shell as follows:

- () Brown wire into hole 1.
- () Red wire into hole 2.

- () Orange wire into hole 3.
- () Yellow wire into hole 4.
- () Green wire into hole 5.

Connect the free end of the prepared cable to the audio circuit board as follows. Solder each wire to the foil as you connect it and cut off any excess lead lengths.

- () Brown wire to hole 1.
- () Red wire to hole 2.
- () Orange wire to hole 3.
- () Yellow wire to hole 4.
- () Green wire to hole 5.

Refer to Pictorial 4-14 (Illustration Booklet, Page 6) for the following steps.

- () Prepare the following white-violet solid wires. The wires are listed in the order in which you will use them.

1-5/8"	1-1/8"
3-1/4"	1-1/8"
1-3/16"	1-3/8"
1-3/4"	1-1/4"

Connect the prepared wires to the audio circuit board as follows. Solder each wire to the foil as you connect it and cut off any excess lead lengths.

- () 1-5/8" wire from hole A to hole A.

- () 3-1/4" wire from hole B to hole B.
 () 1-3/16" wire from hole C to hole C.
 () 1-3/4" wire from hole D to hole D.
 () 1-1/8" wire from hole E to hole E.
 () 1-1/8" wire from hole F to hole F.
 () 1-3/8" wire from hole G to hole G.
 () 1-1/4" wire from hole H to hole H.

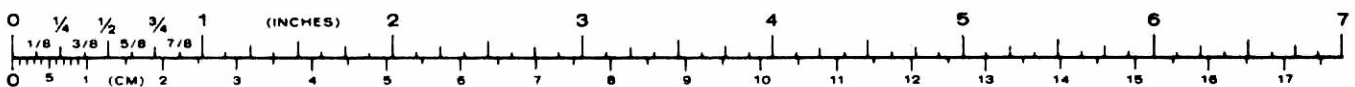

START

() Turn the circuit board over and position it as shown.

() Cut both leads of a 100kΩ (brn-blk-yel) resistor to 1/4". Then bend the leads to the dimensions shown.

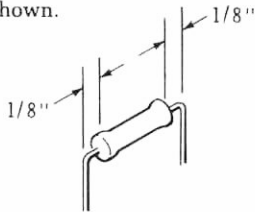

() Locate the foil patterns within the circle shown in the Pictorial. Then insert the resistor leads in the two foil patterns and solder them.

CIRCUIT BOARD CHECKOUT

- () Carefully inspect the circuit board for the following conditions.
- () Unsoldered connections.
- () Poor solder connections.
- () Solder bridges between foil patterns.
- () Protruding leads which could touch together.
- () Transistors for the proper type and installation.
- () Electrolytic capacitors for the correct position of the positive (+) marks.
- () Diodes for the correct position of the banded end.
- () Integrated circuits for the proper type and installation.



PICTORIAL 4-15

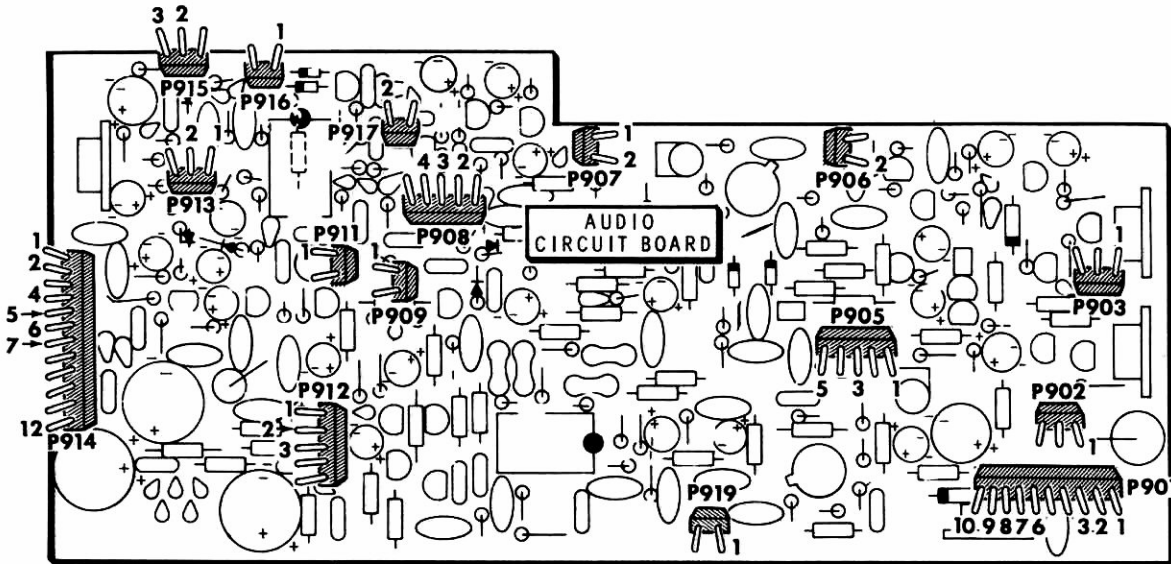

PICTORIAL 4-16

INITIAL TESTS

NOTE: In the following steps, the setting of your ohmmeter is indicated in parentheses, "(R × 10k)" for example, because meaningful readings cannot be taken using a single range. Be sure to zero your ohmmeter each time you change its range.

Refer to Pictorial 4-16 for the following steps.

- () Connect the common ohmmeter lead to a ground point on the audio circuit board foil. NOTE: A convenient point is a foil pad at one of the corner circuit board mounting holes.

Use the positive ohmmeter probe to check for the proper readings at the following audio circuit board plugs and pins. Note that, as on the previous circuit boards, the steps are abbreviated.

NOTE: Do not change ohmmeter ranges unless a step directs you to do so.

- () P901-1, 2 & 3. 6000 Ω or greater. Check U903, Q915, Q918, Q922. (R \times 1000).
- () P901-6 through 10. 200 Ω to 500 Ω . Check U903, and the circuit board for solder bridges. (R \times 10).
- () P902-1, 2, & 3. 10 k Ω or greater. Check Q917, Q918, Q919. (R \times 1000).
- () P903-1, 2, & 3. 4000 Ω to 5500 Ω . Check Q904, Q906, Q915, Q916.
- () P905-1. 20 k Ω or greater. Check Q912, C949.
- () P905-3. 20 k Ω or greater. Check C933, C934, D903, D904.
- () P905-5. Infinity. Check C932, C957. (R \times 10k).
- () P906-2. Infinity. Check C929.
- () P907-1 & 2. 20 k Ω or greater. Check U901D.
- () P908-2. 6000 Ω or greater. Check U904, U905D, C962, C959. (R \times 1000).
- () P908-3 & 4. Infinity. Check Q901, D902. (R \times 10k).
- () P909-1. Infinity. Check C903.
- () P911-1. Infinity. Check C902.
- () P912-1. Charge to 50 k Ω or greater. Check Q927, Q928.
- () P912-2. Infinity. Check C985.
- () P912-3. Infinity. Check C975.
- () P913-1. 50 k Ω or greater. Check C101, U101B.
- () P913-2. Infinity. Check C908. (R \times 1000).
- () P914-1. Infinity. Check Q921, C955. (R \times 10k).
- () P914-2. Charge to 300 k Ω or greater. Check Q921, C956.
- () P914-4. 10 k Ω or greater. Check Q908. (R \times 1000).
- () P914-5. 40 k Ω or greater. Check C101, U901B.
- () P914-6. 40 k Ω or greater. Check Q926, C997.
- () P914-7, 8, & 9. 300 k Ω or greater. Check C996, L903, C987, C989.
- () P914-12. 50 k Ω or greater. Check C992, C993, C994. (R \times 10k).
- () P915-2. 120 k Ω to 1 M Ω . Check D901, U901A. (R \times 100k).
- () P915-3. Infinity. Check C905, C906. (R \times 10k).
- () P916-1 & 2. Infinity. Check D911, Q907.
- () P917-2. Infinity. Check C912.
- () P919-1. Infinity. Check C958.

This completes the "Initial Tests" of your audio circuit board. Set the circuit board aside until it is called for during the assembly of the chassis. Proceed to "High VCO Assembly."

HIGH VCO ASSEMBLY

PARTS LIST

- () Refer to the Pack Index Sheet and locate Pack #5. Then remove the parts from this pack and check each part against the following list. The key numbers correspond to the numbers on the "High VCO Assembly Parts Pictorial" (Illustration Booklet, Page 6). Return any part that is packed in an individual envelope, with the part number on it, back into its envelope until that part is called for in a step. Do not throw away

any packing material until you account for all the parts.

To order a replacement part, always include the PART NUMBER. Use the Parts Order Form furnished with this kit. If a Parts Order Form is not available, refer to "Replacement Parts" inside the rear cover of this Manual. For prices, refer to the separate "Heath Parts Price List."

KEY No.	HEATH Part No.	QTY.	DESCRIPTION	CIRCUIT Comp. No.
---------	----------------	------	-------------	-------------------

RESISTORS

NOTES:

- Resistors may be packed in more than one envelope. Open all of the resistor envelopes in this pack before you check the resistors against the following Parts List.
- The following resistors are rated at 1/4-watt and have a tolerance of 5% (fourth band gold) unless otherwise noted.

A1	6-101-12	2	100 Ω (brn-blk-brn)	R352, R367
A1	6-102-12	1	1000 Ω (brn-blk-red)	R351
A1	6-222-12	3	2200 Ω (red-red-red)	R354, R356, R358
A1	6-472-12	1	4700 Ω (yel-viol-red)	R363
A1	6-103-12	3	10 kΩ (brn-blk-org)	R364, R365, R366
A1	6-823-12	1	82 kΩ (gry-red-org)	R361
A1	6-104-12	2	100 kΩ (brn-blk-yel)	R359, R362
A1	6-105-12	3	1 MΩ (brn-blk-grn)	R353, R355, R357

KEY No.	HEATH Part No.	QTY.	DESCRIPTION	CIRCUIT Comp. No.
---------	----------------	------	-------------	-------------------

CAPACITORS

B1	21-61	2	6.8 pF ceramic	C353, C356
B1	21-3	1	10 pF ceramic	C365
B1	21-60	1	18 pF ceramic	C359
B1	21-140	1	.001 μF (1000 pF) ceramic	C364
B2	21-145	5	.001 μF ceramic feedthrough	C367, C368, C369, C371, C372
B1	21-192	5	.1 μF (104M) ceramic	C351, C354, C357, C361, C366
B3	31-83	1	2-6 pF ceramic trimmer (red screw)	C362
B3	31-71	3	3.2-18 pF ceramic trimmer (blue screw)	C352, C355, C358

INDUCTORS

C1	40-1990	1	.75 μH variable	L352
C2	45-604	1	100 μH choke (brn-blk-brn)	L351

Heathkit®

KEY No.	HEATH Part No.	QTY.	DESCRIPTION	CIRCUIT Comp. No.	KEY No.	HEATH Part No.	QTY.	DESCRIPTION	CIRCUIT Comp. No.
DIODES					MISCELLANEOUS				
D1	56-56	6	1N4149	D352, D353, D354, D355, D356, D357 D351	F1	75-87	1	Feedthrough insulator	
D2	56-648	1	MV109			85-2687-2	1	High VCO circuit board	
TRANSISTORS					F2	200-661	2	Chassis half	
NOTE: Transistors may be marked for identification in any of the following four ways:					F3	205-1876	1	Cover plate	
1. Part number.					F4	250-365	2	#6 × 1/4" hex head sheet metal screw	
2. Type number.					F5	250-475	2	#6 × 3/8" hex head sheet metal screw	
3. Part number and type number.					F6	259-29	1	Long #6 solder lug	
4. Part number with a type number other than the one listed.									
E1	417-154	1	2N2369	Q356					
E2	417-241	1	EL131	Q355					
E2	417-169	1	MPF105	Q354					
E2	417-134	3	MPS6520	Q351, Q352, Q353					

STEP-BY-STEP ASSEMBLY

START

Position the high VCO circuit board as shown with its printed side (not the foil side) up.

() R354: 2200Ω (red-red-red).

NOTE: DIODES MAY BE SUPPLIED IN ANY OF THE FOLLOWING SHAPES. ALWAYS POSITION THE BANDED END AS SHOWN ON THE CIRCUIT BOARD.

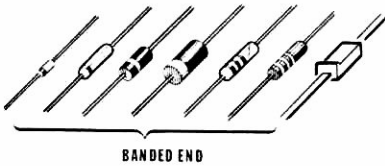

() D356: 1N4149 diode (#56-56).

() R356: 2200Ω (red-red-red).

() D354: 1N4149 diode (#56-56).

() D353: 1N4149 diode (#56-56).

() R358: 2200Ω (red-red-red).

() R352: 100Ω (brn-blk-brn).

() R361: 82kΩ (gry-red-org).

() Solder the leads to the foil and cut off the excess lead lengths.

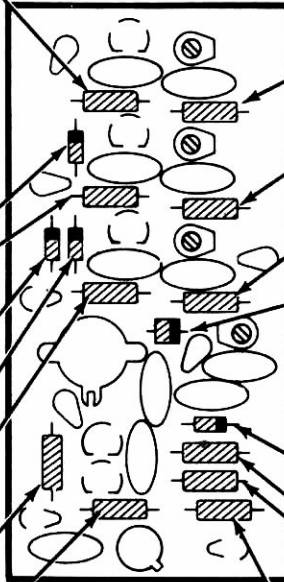

PICTORIAL 5-1

CONTINUE

() R353: 1MΩ (brn-blk-grn).

() R355: 1MΩ (brn-blk-grn).

() R357: 1MΩ (brn-blk-grn).

() D351: MV109 diode (#56-648). Match the marked end with the band on the board.

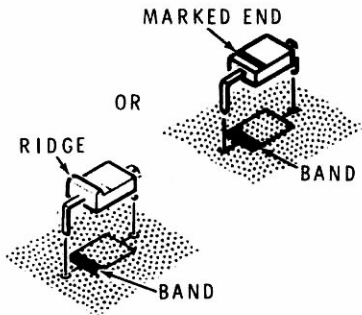

() D357: 1N4149 diode (#56-56).

() R359: 100 kΩ (brn-blk-yel). NOTE: Your circuit board may be marked 1 M.

() R362: 100 kΩ (brn-blk-yel).

() R363: 4700 Ω (yel-viol-red).

() Solder the leads to the foil and cut off the excess lead lengths.

START

When you install a trimmer capacitor, align its flat with the flat on the board. Insert the leads as far as possible into their holes and solder the leads to the foil.

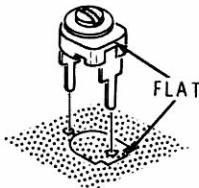

() C352: 3.2-18 pF trimmer (blue screw).

() C355: 3.2-18 pF trimmer (blue screw).

() C358: 3.2-18 pF trimmer (blue screw).

() C362: 2-6 pF trimmer (red screw).

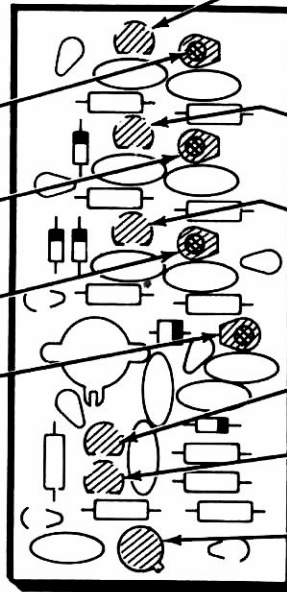

CONTINUE

NOTE: When you install a transistor in each of the following six steps, align its flat with the flat on the board OR the tab with the tab on the board. Insert the leads into their correct holes. Position the transistor 1/4" above the board. Then solder the leads to the foil and cut off the excess lead lengths.

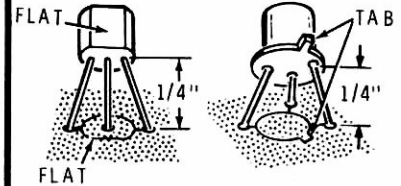

() Q351: MPS6520 transistor (#417-134).

() Q352: MPS6520 transistor (#417-134).

() Q353: MPS6520 transistor (#417-134).

() Q354: MPF105 transistor (#417-169).

() Q355: EL131 transistor (#417-241).

() Q356: 2N2369 transistor (#417-154).

PICTORIAL 5-2

START ↘

- C354: .1μF (104M) ceramic.

- C357: .1μF (104M) ceramic.

- C361: .1μF (104M) ceramic.

- C351: .1μF (104M) ceramic.

- C365: 10 pF ceramic.

- C366: .1μF (104M) ceramic.

- Solder the leads to the foil and cut off the excess lead lengths.

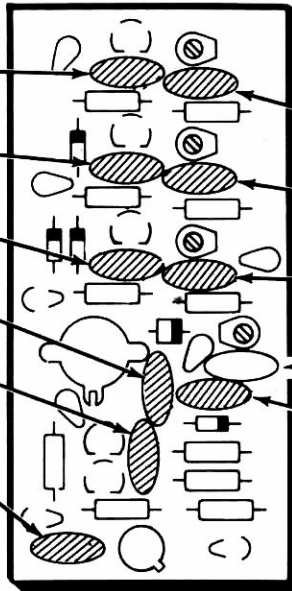

CONTINUE ↙

- C353: 6.8 pF ceramic.

- C356: 6.8 pF ceramic.

- C359: 18 pF ceramic.

- Do not install a capacitor at this location.

- C364: .001 μF (1000 pF) ceramic.

- Solder the leads to the foil and cut off the excess lead lengths.

PICTORIAL 5-3

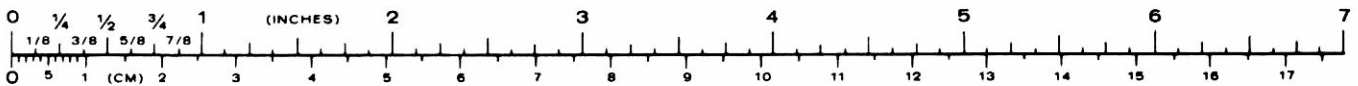

START

NOTE: Solder each wire or component lead to the foil as you install it. Then cut off the excess lead end. Position each component the indicated distance from the board before you solder the connection.

- () D352: 1N4149 diode (#56-56). The lead at the banded end goes into board hole 15.
- () D355: 1N4149 diode (#56-56). The lead at the banded end goes into the board hole 17.

When a wire is called for in this Pictorial, cut the white solid wire to the specified length and remove 1/4" of insulation from each end.

- () 1-1/4" wire into board hole 20.
- () 2-1/4" wire between board holes J.
- () 1-3/8" wire into board hole + 12.

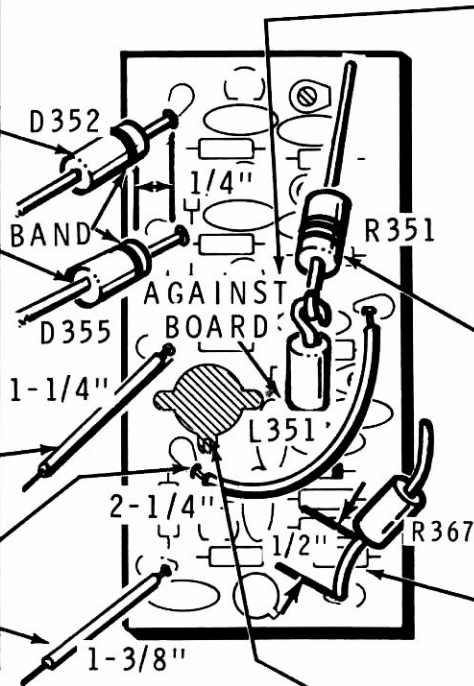

PICTORIAL 5-4

CONTINUE

- () L351: 100 μ H choke (#45-604, brn-blk-brn) at hole T. Position one end 1/16" above the board. Cut its top lead to 1/4" and bend it to form a loop. Be careful not to put any stress on the leads of this choke.

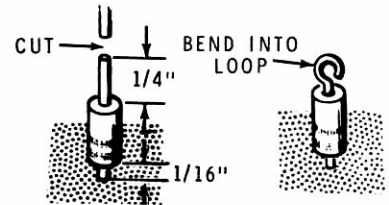

- () R351: 1000 Ω (brn-blk-red). Cut one lead to 1/4" and bend it to form a loop. Then solder it to the choke.

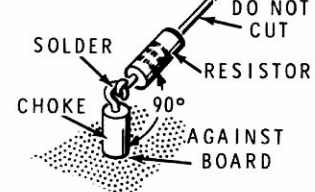

- () R367: 100 Ω (brn-blk-brn) into hole OUT.

- () L352: .75 μ H variable inductor (#40-1990).

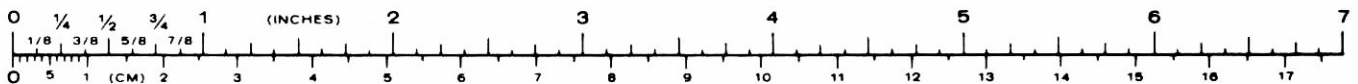

START →

- () Position one VCO chassis half as shown.

- () Position the circuit board as shown. Then slide the circuit board between the three ground lugs on the chassis half.

- () Keep the assembly in this position and slide the other chassis half into place. Note that the flange on each chassis half is on the outside.

- () Fasten the two chassis halves together at the indicated corner with a long #6 solder lug and a #6 × 1/4" hex head sheet metal screw. Push a 1-5/8" length of medium heat shrink sleeving on the solder lug. See Detail 5-5A.

- () Fasten the two chassis halves together at the other corner with a #6 × 1/4" hex head sheet metal screw.

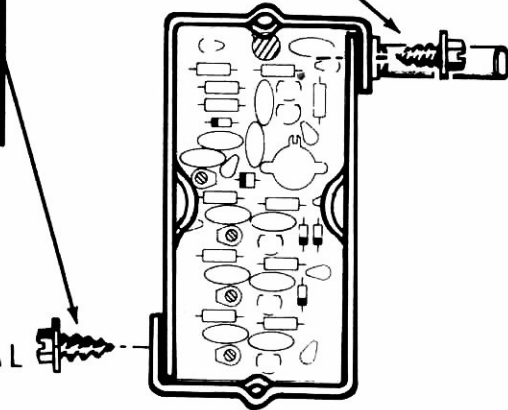
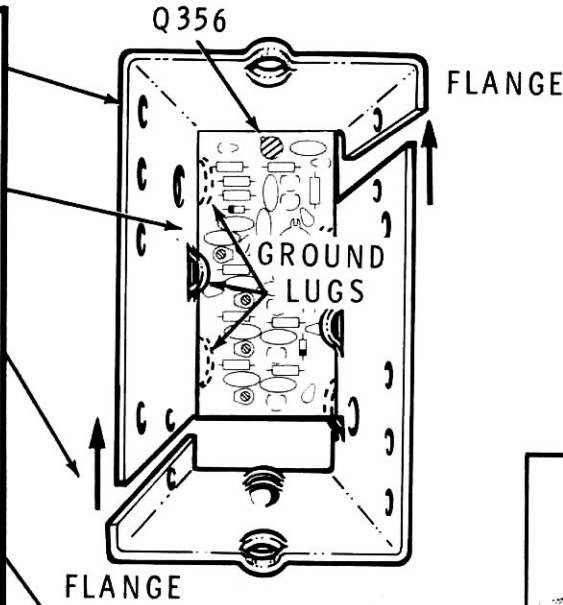

#6 x 1/4"
HEX HEAD
SHEET METAL
SCREW

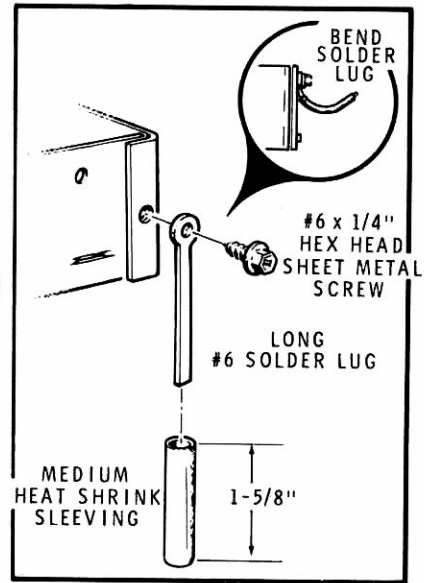

Detail 5-5A

- () Now turn the assembly over, and solder the four ground lugs to the foil.

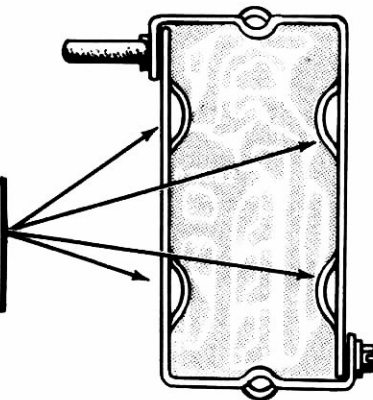

PICTORIAL 5-5

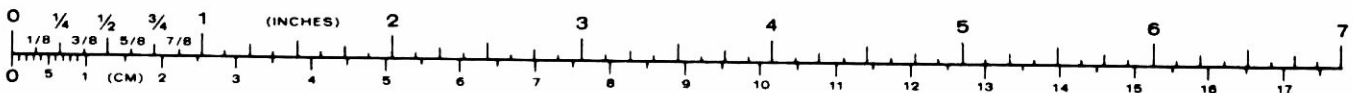

START 

() Position the assembly with transistor Q356 at this end as shown.

() Push the feedthrough insulator (small end first) as tightly as possible into hole A.

Install the following .001 μ F ceramic feedthrough capacitors as shown in Parts A and B below.

A. Use a pencil eraser to clean the outside surface around holes C367, C368, C369, C371, and C372.



B. Insert the longest end of the capacitor into the hole and solder the entire skirt to the chassis. Do not bridge solder across the insulator.

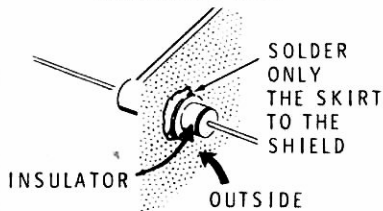

() C368: Feedthrough capacitor.

() C367: Feedthrough capacitor.

() C372: Feedthrough capacitor.

() C371: Feedthrough capacitor.

() C369: Feedthrough capacitor.

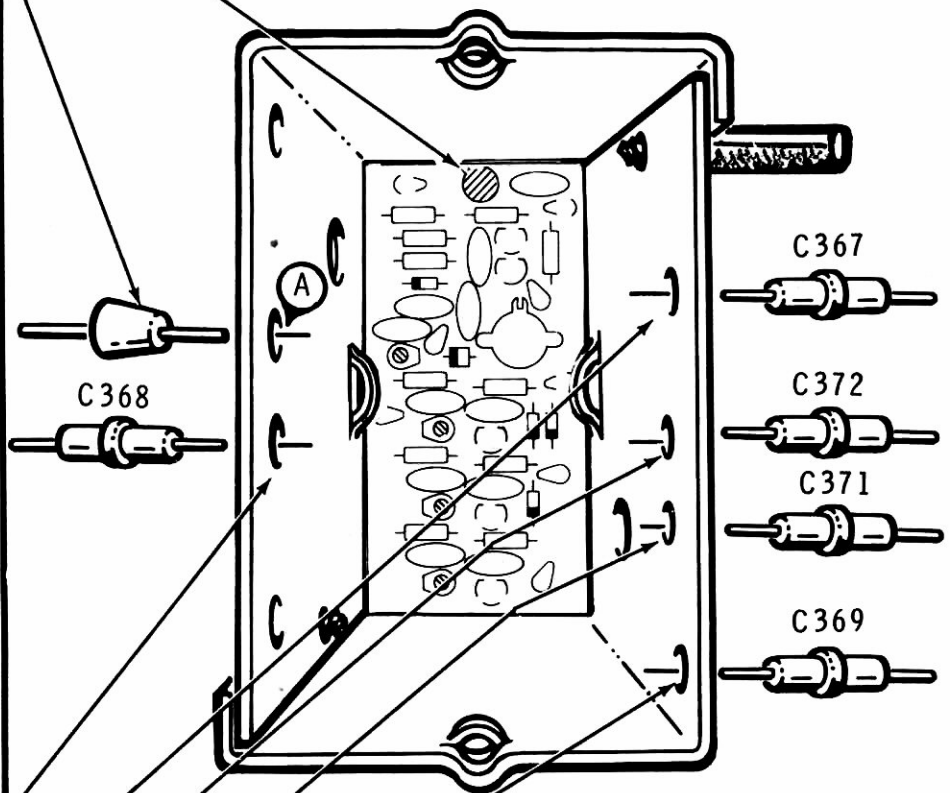

PICTORIAL 5-6

START ↘

NOTE: Keep the leads of the components as short as possible when you connect them in the following steps. Solder each lead and wire end as you connect it. Then cut off any excess lead lengths from the components.

CAUTION: Do not place any strain on a feedthrough capacitor when you connect a wire or lead to them, as in the next step. To do so could damage the ceramic insulation.

() Connect the free lead from R367 to the feedthrough insulator at hole A.

() Connect the free lead of R351 to C368.

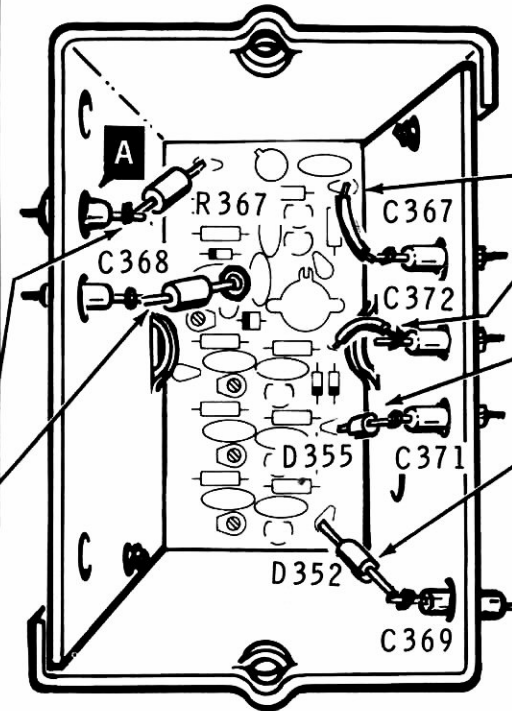
**CONTINUE** ↘

() Connect the free end of the wire coming from hole +12 to C367.

() Connect the free end of the wire coming from hole 20 to C372.

() Connect the free lead of diode D355 to C371.

() Connect the free lead of diode D352 to C369.

PICTORIAL 5-7

START

NOTE: There are two unused holes in the circuit board.

CIRCUIT BOARD CHECKOUT

Carefully inspect the circuit board for the following conditions.

- () Unsoldered connections.
- () Poor solder connections.
- () Solder bridges between foil patterns.
- () Protruding leads which could touch together.
- () Transistors for the proper type and installation.
- () Diodes for proper type and position of banded end.

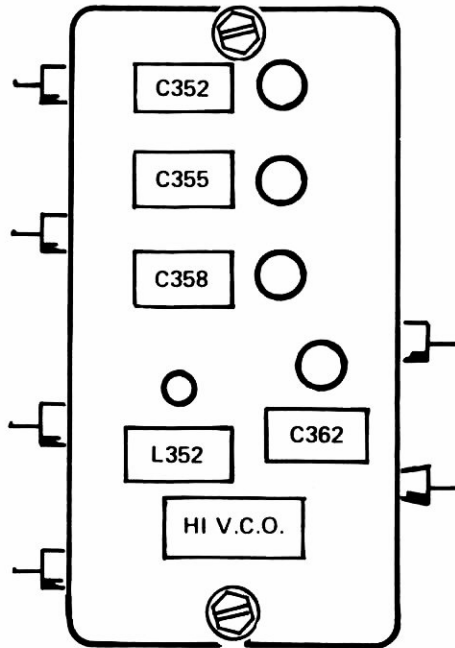

Detail 5-8A

CONTINUE

INITIAL TEST

- () With your ohmmeter set to $R \times 1000$, measure the resistances on the leads of the five feedthrough capacitors and the feedthrough insulator. Check to make sure none of these connections indicate a direct short (0Ω) to the enclosure frame.

Assembly Continued

- () Use a screwdriver to pry all five plugs from the cover plate.
- () Position the cover plate so the indicated hole is directly above the coil. Then fasten the cover with two $\#6 \times 3/8$ " hex head sheet metal screws.

When you install the resistors in the following steps, solder their leads only at the ground lug after all three resistors are installed. The leads at the feedthrough capacitors will be soldered later.

- () R366: 10 k Ω (brn-blk-org).
- () R365: 10 k Ω (brn-blk-org).
- () R364: 10 k Ω (brn-blk-org).

- () Apply labels from the label sheet to the cover plate as shown in Detail 5-8A. Then set the assembly aside until it is called for during the assembly of the chassis.

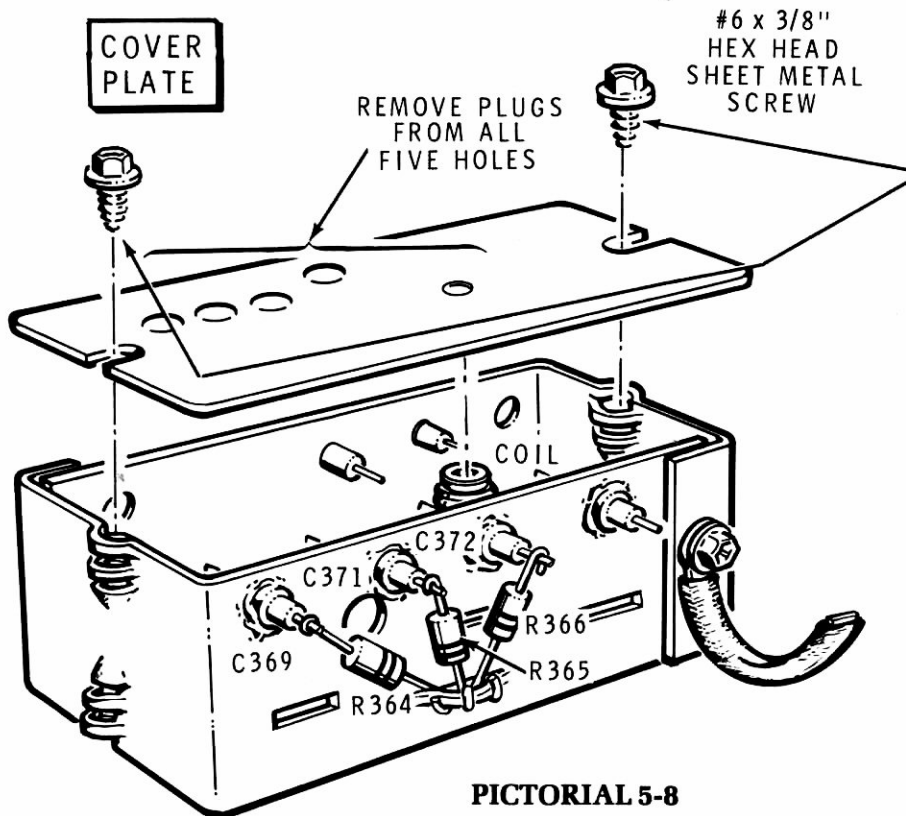

PICTORIAL 5-8

LOW VCO ASSEMBLY

PARTS LIST

() Refer to the Pack Index Sheet and locate Pack #6. Then remove the parts from this pack and check each part against the following list. The key numbers correspond to the numbers on the "Low VCO Assembly Parts Pictorial" (Illustration Booklet, Page 7). Return any part that is packed in an individual envelope, with the part number on it, back into its envelope until that part is called for in a step. Do not throw away

any packing material until you account for all the parts.

To order a replacement part, always include the PART NUMBER. Use the Parts Order Form furnished with this kit. If a Parts Order Form is not available, refer to "Replacement Parts" inside the rear cover of this Manual. For prices, refer to the separate "Heath Parts Price List."

KEY No.	HEATH Part No.	QTY.	DESCRIPTION	CIRCUIT Comp. No.
---------	----------------	------	-------------	-------------------

KEY No.	HEATH Part No.	QTY.	DESCRIPTION	CIRCUIT Comp. No.
---------	----------------	------	-------------	-------------------

RESISTORS

NOTES:

- Resistors may be packed in more than one envelope. Open all of the resistor envelopes in this pack before you check the resistors against the following Parts List.
- The following resistors are rated at 1/4-watt and have a tolerance of 5% (fourth band gold) unless otherwise noted.

A1	6-101-12	2	100 Ω (brn-blk-brn)	R302, R312
A1	6-102-12	1	1000 Ω (brn-blk-red)	R301
A1	6-222-12	2	2200 Ω (red-red-red)	R304, R306
A1	6-472-12	1	4700 Ω (yel-viol-red)	R311
A1	6-103-12	2	10 kΩ (brn-blk-org)	R313, R314
A1	6-823-12	1	82 kΩ (gry-red-org)	R308
A1	6-104-12	2	100 kΩ (brn-blk-yel)	R307, R309
A1	6-105-12	2	1 MΩ (brn-blk-grn)	R303, R305

CAPACITORS

B1	21-33	1	3.3 pF ceramic	C303
B1	21-3	1	10 pF ceramic	C312
B1	21-60	1	18 pF ceramic	C306
B1	21-140	1	.001 μF (1000 pF) ceramic	C311
B2	21-145	4	.001 μF ceramic feedthrough	C314, C315, C316, C317
B1	21-192	4	.1 μF (104M) ceramic	C301, C304, C307, C313
B3	31-71	3	3.2-18 pF ceramic trimmer (blue screw)	C302, C305, C309

INDUCTORS

C1	40-2066	1	2 μH variable	L302
C2	45-604	1	100 μH choke (brn-blk-brn)	L301

Heathkit®

KEY No.	HEATH Part No.	QTY.	DESCRIPTION	CIRCUIT Comp. No.
---------	----------------	------	-------------	-------------------

DIODES

D1	56-56	3	1N4149	D302, D303, D304
D2	56-648	1	MV109	D301

TRANSISTORS

NOTE: Transistors may be marked for identification in any of the following four ways:

1. Part number.
2. Type number.
3. Part number and type number.
4. Part number with a type number other than the one listed.

E1	417-154	1	2N2369	Q305
E2	417-241	1	EL131	Q304
E2	417-169	1	MPF105	Q303
E2	417-134	2	MPS6520	Q301, Q302

KEY No.	HEATH Part No.	QTY.	DESCRIPTION	CIRCUIT Comp. No.
---------	----------------	------	-------------	-------------------

MISCELLANEOUS

F1	75-87	1	Feedthrough insulator	
	85-2687-1	1	Low VCO circuit board	
F2	200-661	2	Chassis half	
F3	205-1876	1	Cover plate	
F4	250-365	2	#6 × 1/4" hex head sheet metal screw	
F5	250-475	2	#6 × 3/8" hex head sheet metal screw	
F6	259-29	1	Long #6 solder lug	

STEP-BY-STEP ASSEMBLY

START

Position the low VCO circuit board as shown with its printed side (not the foil side) up.

() R304: 2200Ω (red-red-red).

NOTE: DIODES MAY BE SUPPLIED IN ANY OF THE FOLLOWING SHAPES. ALWAYS POSITION THE BANDED END AS SHOWN ON THE CIRCUIT BOARD.

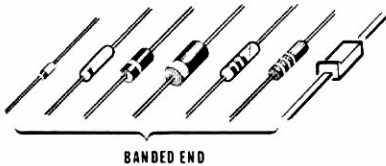

() D303: 1N4149 diode (#56-56).

() R306: 2200Ω (red-red-red).

() R302: 100Ω (brn-blk-brn).

() R308: 82kΩ (gry-red-org).

() Solder the leads to the foil and cut off the excess lead lengths.

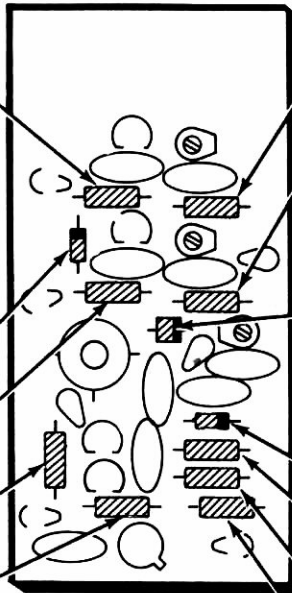

PICTORIAL 6-1

CONTINUE

() R303: 1MΩ (brn-blk-grn).

() R305: 1 MΩ (brn-blk-grn).

() D301: MV109 diode (#56-648). Match the marked end with the band on the board.

MARKED END

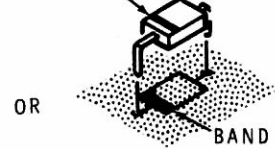

OR

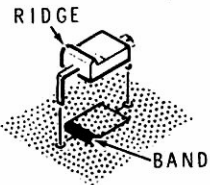

() D304: 1N4149 diode (#56-56).

() R307: 100 kΩ (brn-blk-yel). NOTE: Your circuit board may be marked 1 M.

() R309: 100 kΩ (brn-blk-yel).

() R311: 4700 Ω (yel-viol-red).

() Solder the leads to the foil and cut off the excess lead lengths.

START

When you install a trimmer capacitor, align its flat with the flat on the board. Insert the leads as far as possible into their holes and solder the leads to the foil.

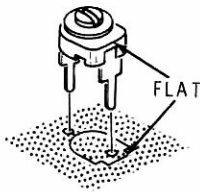

- () C302: 3.2-18 pF trimmer (blue screw).
- () C305: 3.2-18 pF trimmer (blue screw).
- () C309: 3.2-18 pF trimmer (blue screw).

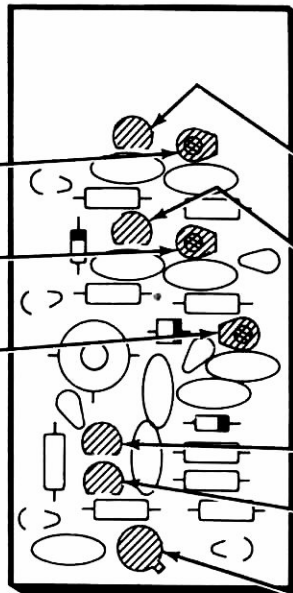

PICTORIAL 6-2

CONTINUE

NOTE: When you install a transistor in each of the following five steps, align its flat with the flat on the board OR the tab with the tab on the board. Insert the leads into their correct holes. Position the transistor 1/4" above the board. Then solder the leads to the foil and cut off the excess lead lengths.

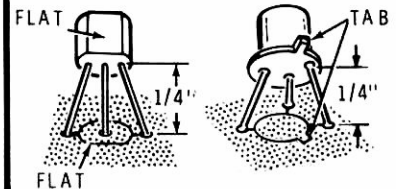

- () Q301: MPS6520 transistor (#417-134).
- () Q302: MPS6520 transistor (#417-134).
- () Q303: MPF105 transistor (#417-169).
- () Q304: EL131 transistor (#417-241).
- () Q305: 2N2369 transistor (#417-154).

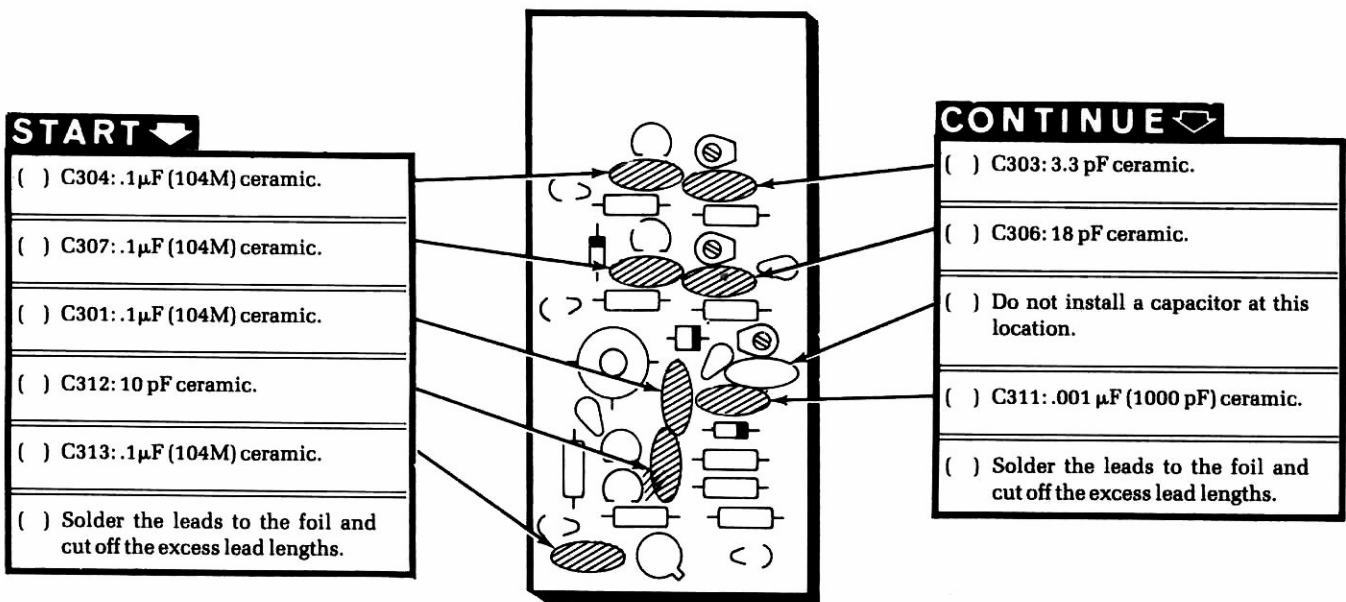

PICTORIAL 6-3

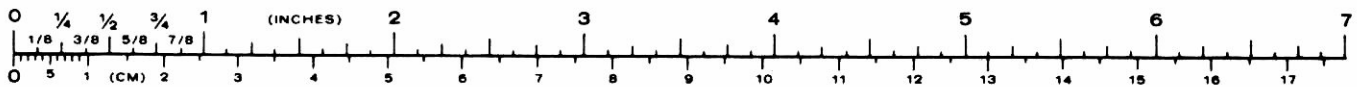

START ▾

NOTE: Solder each wire or component lead to the foil as you install it. Then cut off the excess lead end. Position each component the indicated distance above the board before you solder the connection.

() D302: 1N4149 diode (#56-56). The lead at the banded end goes into board hole 40.

When a wire is called for in this Pictorial, cut the white solid wire to the specified length and remove 1/4" of insulation from each end.

() 1-1/4" wire into board hole 80.

() 2-1/4" wire between board holes J.

() 1-3/8" wire into board hole + 12.

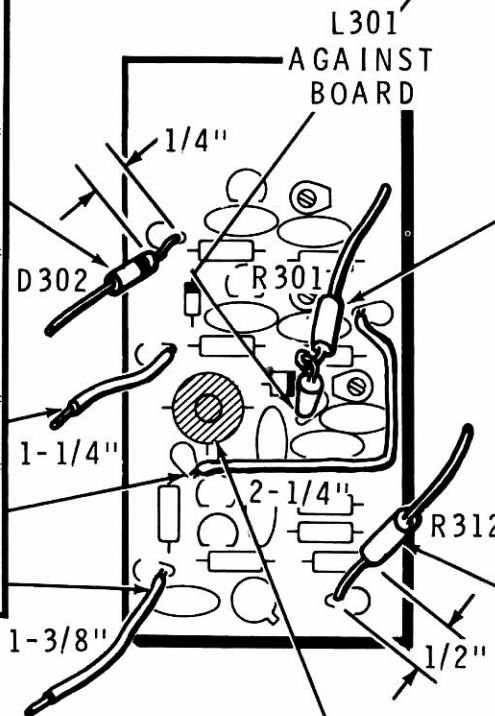

PICTORIAL 6-4

CONTINUE ▾

() L301: 100 μ H choke (#45-604, brn-blk-brn) at hole T. Position one end 1/16" above the board. Cut its top lead to 1/4" and bend it to form a loop. Be careful not to put any stress on the leads of this choke.

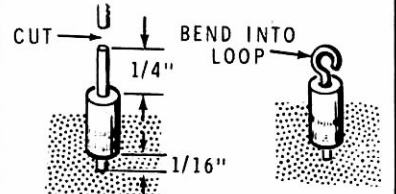

() R301: 1000 Ω (brn-blk-red). Cut one lead to 1/4" and bend it to form a loop. Then solder it to the choke.

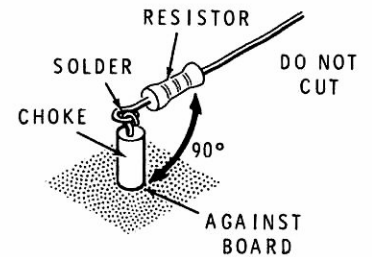

() R312: 100 Ω (brn-blk-brn) into hole OUT.

() L302: 2 μ H variable inductor (#40-2066).

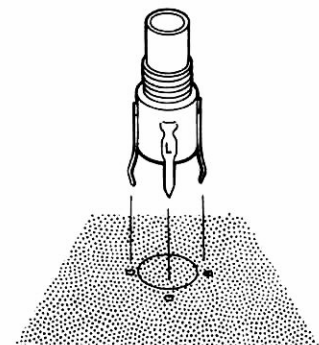

START →

- () Position one VCO chassis half as shown.

- () Position the circuit board as shown. Then slide the circuit board between the three ground lugs on the chassis half.

- () Keep the assembly in this position and slide the other chassis half into place. Note that the flange on each chassis is on the outside.

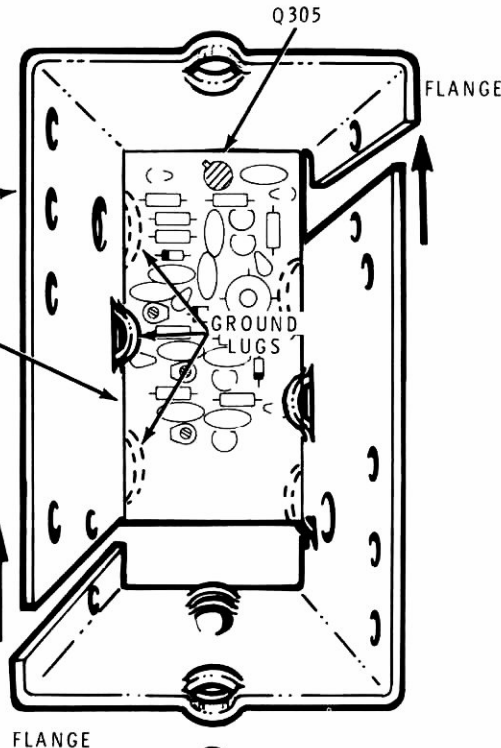

- () Fasten the two chassis halves together at the indicated corner with a long #6 solder lug and a #6 x 1/4" hex head sheet metal screw. Push a 1-5/8" length of medium heat shrink sleeving on the solder lug. See Detail 6-5A.

- () Fasten the two chassis halves together at the other corner with a #6 x 1/4" hex head sheet metal screw.

#6 x 1/4" HEX HEAD SHEET METAL SCREW

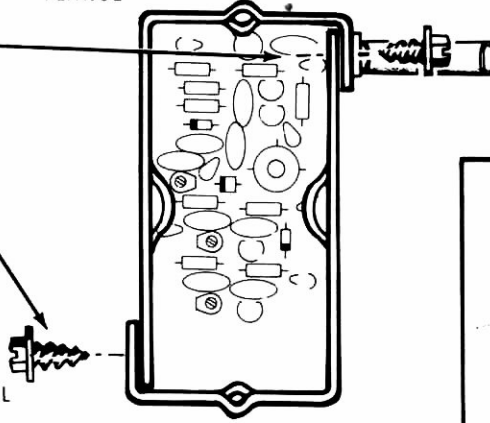

- () Now turn the assembly over, and solder the four ground lugs to the foil.

PICTORIAL 6-5

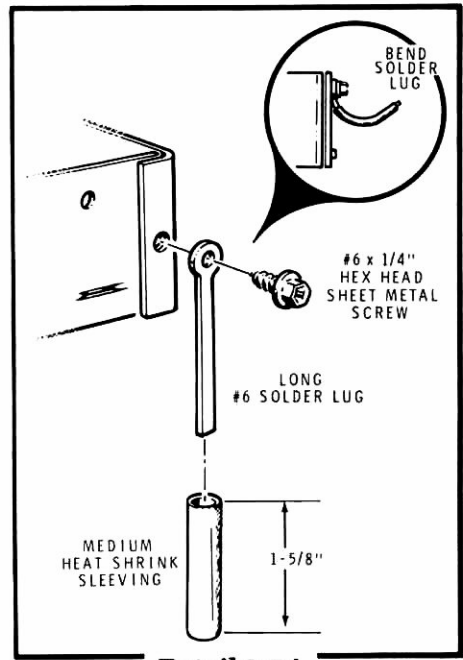

Detail 6-5A

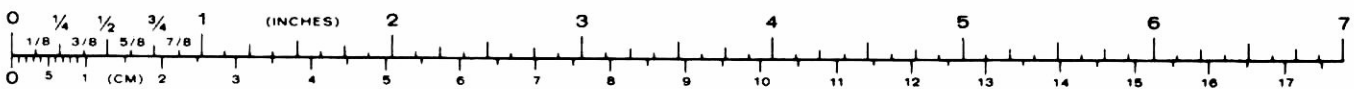

START

- () Position the assembly with transistor Q305 at this end as shown.
- () Push the feedthrough insulator (small end first) as tightly as possible into hole A.

Install the following .001 μ F ceramic feedthrough capacitors as shown in Parts A and B below.

- A. Use a pencil eraser to clean the outside surface around holes C315, C314, C317, and C316.

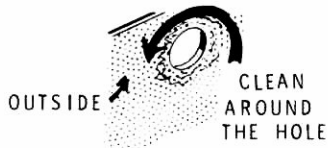

- B. Insert the longest end of the capacitor into the hole and solder the entire skirt to the chassis. Do not bridge solder across the insulator.

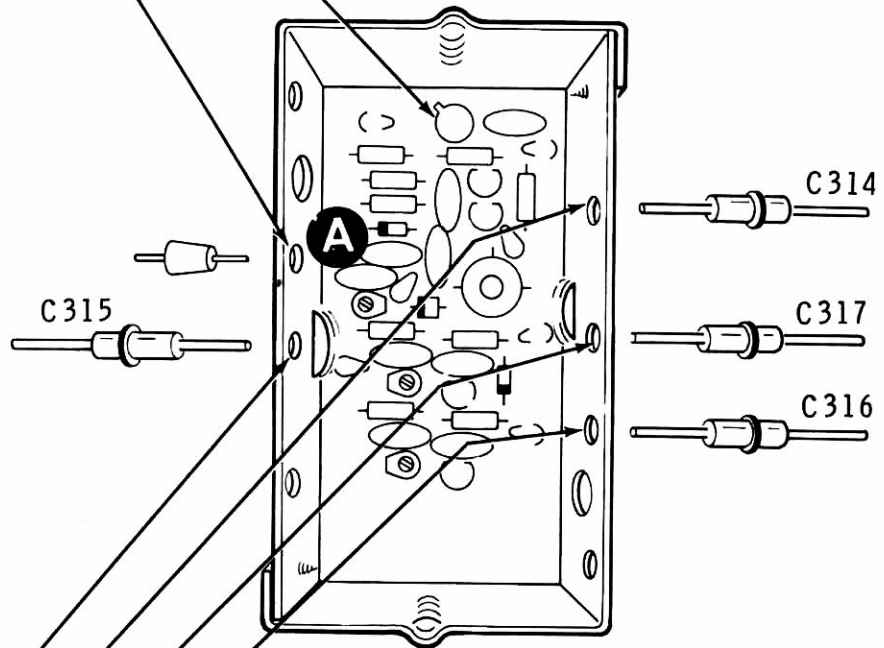
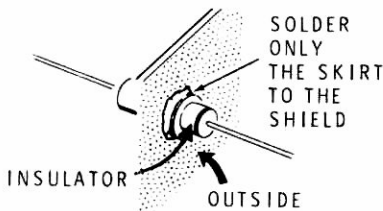

PICTORIAL 6-6

- () C315: Feedthrough capacitor.
- () C314: Feedthrough capacitor.
- () C317: Feedthrough capacitor.
- () C316: Feedthrough capacitor.

START →

NOTE: Keep the leads of the components as short as possible when you connect them in the following steps. Solder each lead and wire end as you connect it. Then cut off any excess lead lengths from the components.

- () Connect the free lead from R312 to the feedthrough insulator at hole A.
- () Connect the free lead of R301 to C315.

CONTINUE →

- () Connect the free end of the wire coming from hole +12 to C314.
- () Connect the free end of the wire coming from hole 80 to C317.
- () Connect the free lead of diode D302 to C316.

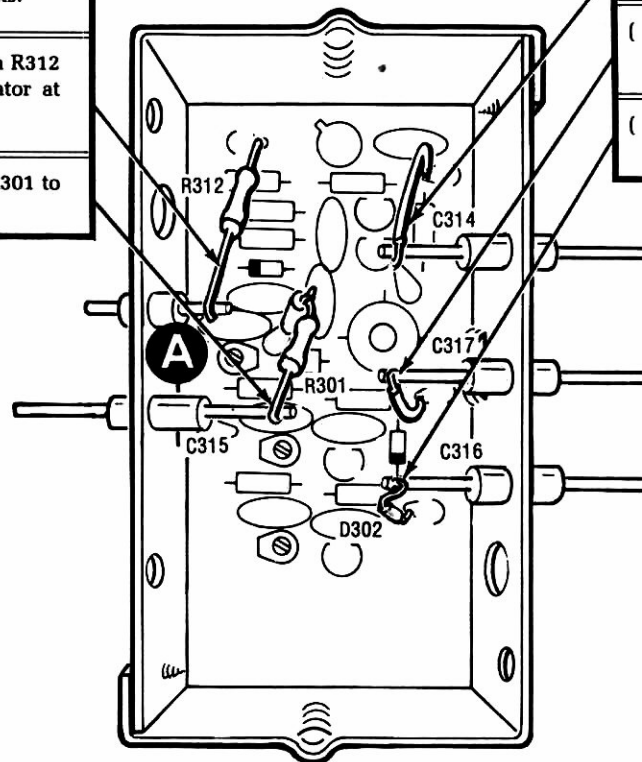

PICTORIAL 6-7

START

NOTE: There are 20 unused holes in the circuit board.

CIRCUIT BOARD CHECKOUT

Carefully inspect the circuit board for the following conditions.

- () Unsoldered connections.
- () Poor soldered connections
- () Solder bridges between foil patterns.
- () Protruding leads which could touch together.
- () Transistors for proper type and installation.
- () Diodes for proper type and position of the banded end.

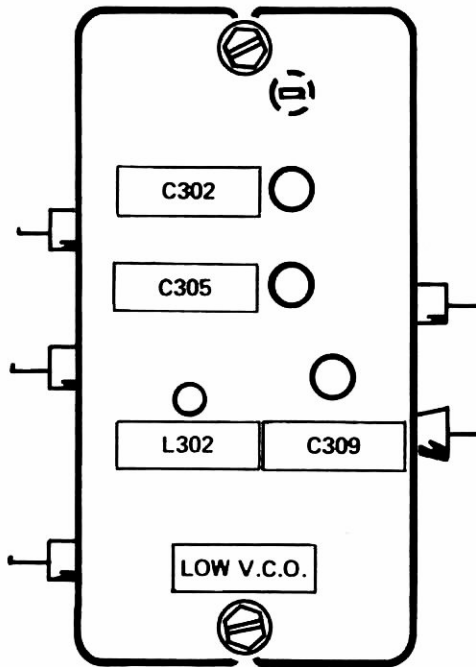

Detail 6-8A

CONTINUE

INITIAL TEST

- () With your ohmmeter set to $R \times 1000$, measure the resistances on the leads of the four feedthrough capacitors and the feedthrough insulator. Check to make sure none of these connections indicate a direct short (0Ω) to the enclosure frame.

Assembly Continued

- () Use a screwdriver to pry the plugs from the four indicated hole locations in the cover plate.
- () Position the cover plate so the indicated hole is directly above the coil. Then fasten the cover with two $\#6 \times 3/8$ " hex head sheet metal screws.

NOTE: When you install the resistors in the following steps, solder their leads only at the ground lug after both resistors have been installed. The leads at the feedthrough capacitors will be soldered later.

- () R313: $10k\Omega$ (brn-blk-org).

- () R314: $10k\Omega$ (brn-blk-org).

- () Apply labels from the label sheet to the cover plate as shown in Detail 6-8A. Then set the assembly aside until it is called for during the assembly of the chassis.

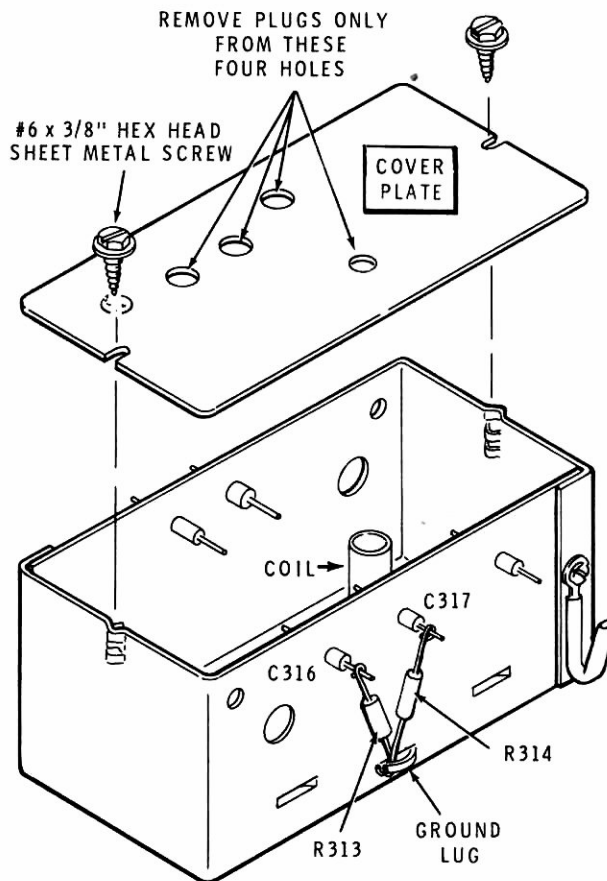

PICTORIAL 6-8

INVERTER ASSEMBLY

PARTS LIST

() Refer to the Pack Index Sheet and locate Pack #7. Then remove the parts from this pack and check each part against the following list. The key numbers correspond to the numbers on the "Inverter Assembly Parts Pictorial" (Illustration Booklet, Page 7). Return any part that is packed in an individual envelope, with the part number on it, back into its envelope until that part is called for in a step. Do not throw away

any packing material until you account for all the parts.

To order a replacement part, always include the PART NUMBER. Use the Parts Order Form furnished with this kit. If a Parts Order Form is not available, refer to "Replacement Parts" inside the rear cover of this Manual. For prices, refer to the separate "Heath Parts Price List."

KEY No.	HEATH Part No.	QTY.	DESCRIPTION	CIRCUIT Comp. No.
---------	----------------	------	-------------	-------------------

RESISTORS

NOTES:

- Resistors may be packed in more than one envelope. Open all of the resistor envelopes in this pack before you check the resistors against the following Parts List.
- The following resistors are rated at 1/4-watt and have a tolerance of 5% (fourth band gold) unless otherwise noted.

A1	6-271-12	2	270 Ω (red-viol-brn)	R503, R506
A2	6-471	1	470 Ω , 1/2-watt (yel-viol-brn)	R507
A2	6-561	1	560 Ω , 1/2-watt (grn-blu-brn)	R508
A1	6-102-12	3	1000 Ω (brn-blk-red)	R501, R504, R505
A1	6-223-12	1	22 k Ω (red-red-org)	R502

KEY No.	HEATH Part No.	QTY.	DESCRIPTION	CIRCUIT Comp. No.
---------	----------------	------	-------------	-------------------

CAPACITORS

Ceramic

B1	21-140	1	.001 μ F (1000 pF)	C503
B2	21-145	3	.001 μ F feedthrough	C513, C514, C515
B1	21-176	1	.01 μ F	C504
B1	21-143	1	.05 μ F	C516

Electrolytic

B3	25-922	1	.68 μ F	C509
B3	25-925	2	4.7 μ F	C507, C508
B3	25-880	4	10 μ F	C502, C505, C506, C511
B4	25-866	2	22 μ F	C501, C512

Heathkit®

KEY No.	HEATH Part No.	QTY.	DESCRIPTION	CIRCUIT Comp. No.
---------	----------------	------	-------------	-------------------

INDUCTORS

C1	45-96	1	100 μ H choke (brn-blk-brn)	L502
C2	45-98	1	Hash filter choke	L501

DIODES

D1	56-93	4	FD333	D501, D502, D503, D504
----	-------	---	-------	---------------------------

TRANSISTORS — INTEGRATED CIRCUITS (ICs)

NOTE: Transistors and integrated circuits may be marked for identification in any of the following four ways:

1. Part number.
2. Type number.
3. Part number and type number. (On integrated circuits, this refers only to the numbers; the letters may be different or missing.)
4. Part number with a type number other than the one listed.

E1	417-819	1	MJE171 transistor	Q501
E1	417-818	1	MJE181 transistor	Q502
E2	442-53	1	NE555 IC	U501
E3	442-681	1	78L08 IC	U503
E4	442-663	1	78M12 IC	U502

KEY No.	HEATH Part No.	QTY.	DESCRIPTION	CIRCUIT Comp No.
---------	----------------	------	-------------	------------------

HARDWARE

F1	250-1412	2	4-40 \times 3/8" black phillips head screw
F2	250-365	2	#6 \times 1/4" hex head sheet metal screw
F3	250-475	4	#6 \times 3/8" hex head sheet metal screw
F4	250-1280	2	6-32 \times 3/8" black phillips head screw
F5	252-2	2	4-40 nut
F6	252-3	2	6-32 nut
F7	254-1	1	#6 lockwasher
F8	254-9	2	#4 lockwasher
F9	259-1	1	#6 solder lug
F10	259-29	1	Long #6 solder lug

MISCELLANEOUS

G1	75-204	2	Transistor insulator
	85-2394-2	1	Inverter circuit board
G2	200-661	2	Chassis half
G3	205-1875	1	Bottom cover
G4	205-1876	1	Top cover
G5	215-667	1	Inverter heat sink
G6	434-230	1	8-pin IC socket

STEP-BY-STEP ASSEMBLY

START ↘

() Position the inverter circuit board with the printed side up.

NOTE: All resistors are 1/4-watt unless stated otherwise in the step.

() R506: 270Ω (red-viol-brn).

() Prepare a 1-3/8" white solid wire. Then install the wire at the indicated location.

() R504: 1000Ω (brn-blk-red).

() R505: 1000Ω (brn-blk-red).

() R503: 270Ω (red-viol-brn).

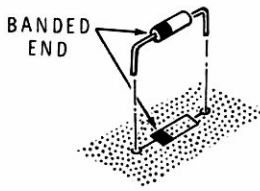

In the following steps, match the band on the diode with the band mark on the circuit board.

() D502: FD333 diode (#56-93).

() D503: FD333 diode (#56-93).

() D504: FD333 diode (#56-93).

() Solder the lead to the foil and cut off the excess lead lengths.

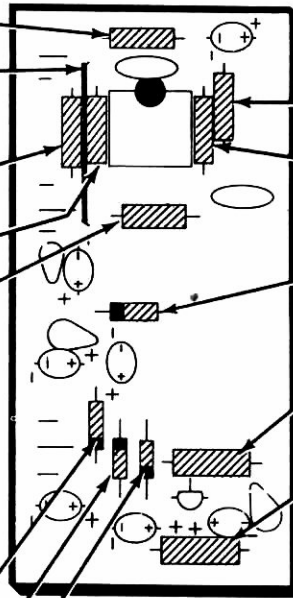

PICTORIAL 7-1

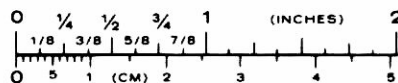

CONTINUE ↘

() R501: 1000Ω (brn-blk-red).

() R502: 22kΩ (red-red-org).

() D501: FD333 diode (#56-93).

() R508: 560Ω, 1/2-watt (grn-bl-brn).

() R507: 470Ω, 1/2-watt (yel-viol-brn).

() Solder the leads to the foil and cut off the excess lead lengths.

START

- () Install an 8-pin IC socket at U501. Be sure the socket pins are all inserted into the circuit board holes. The index mark on the circuit board should be visible after the socket is installed. Solder the pins to the foil.

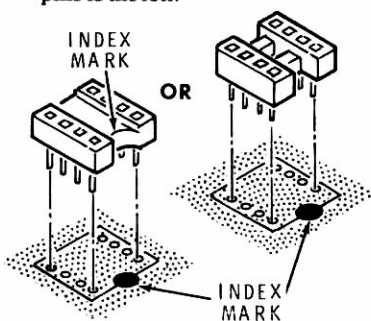

- () U501: Locate the NE-555 8-pin IC (#442-53). Then refer to Detail 7-2A and identify the pin 1 end. Install the IC into the socket with the pin 1 end over the index mark. Make sure all of the IC pins go into the socket.

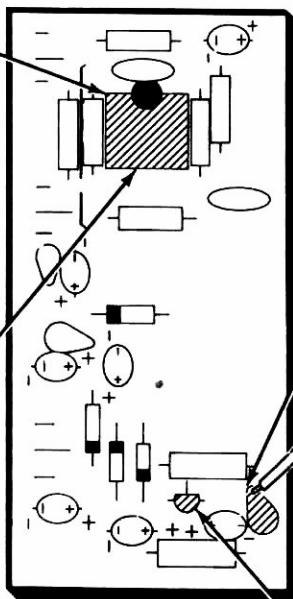
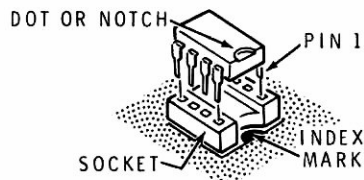

PICTORIAL 7-2

CONTINUE

- () Prepare a 1-1/4" white solid wire. Then install one end of the wire in the circuit board at +20. Solder the wire to the foil and cut off the excess wire end. The other end of this wire will be connected later.

NOTE: When you install the following integrated circuit, position the flat on the IC over the outline of the flat on the circuit board. Then insert the leads into the circuit board holes and solder them to the foil. Cut off the excess lead lengths.

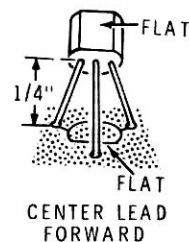

- () U503: 78L08 integrated circuit (#442-681).

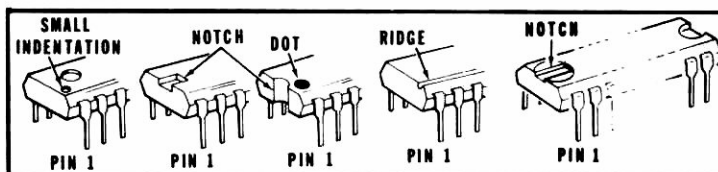

Detail 7-2A

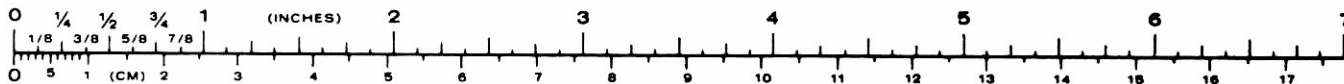

START ↘

NOTE: When you install electrolytic capacitors, always match the positive (+) mark on the capacitor with the positive (+) mark on the circuit board OR match the negative (-) mark on the capacitor with the negative (-) mark on the circuit board. Form the leads to fit the circuit board holes as shown in Detail 7-3A.

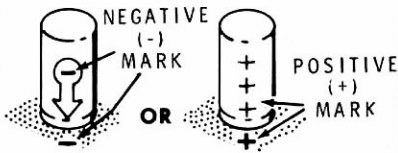

() C505: 10 μ F electrolytic.

NOTE: Be sure to mount the next two electrolytic capacitors away from the edge of the circuit board.

() C511: 10 μ F electrolytic.

() C507: 4.7 μ F electrolytic.

() C508: 4.7 μ F electrolytic.

() Solder the leads to the foil and cut off the excess lead lengths.

CONTINUE ↘

() C502: 10 μ F electrolytic.

NOTE: When you install ceramic capacitors, do not push the insulated portion of the leads into the circuit board holes. This could make it difficult to solder the leads to the foil.

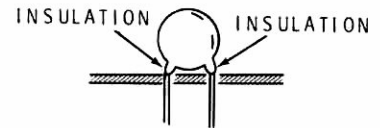

() C503: .001 μ F (1000 pF) ceramic.

() C504: .01 μ F ceramic.

() C506: 10 μ F electrolytic.

() C509: .68 μ F electrolytic.

() Solder the leads to the foil and cut off the excess lead lengths.

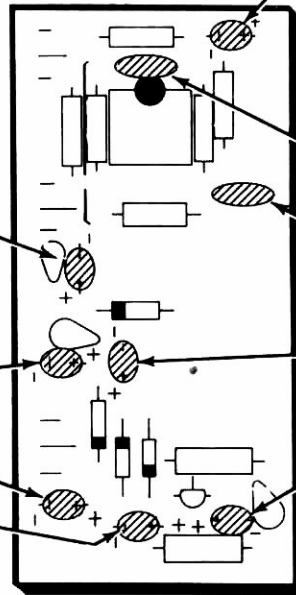

PICTORIAL 7-3

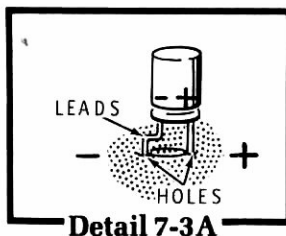

START →

- () Position one chassis half as shown.
- () Position the circuit board as shown. Then slide the circuit board between the three ground lugs on the two chassis halves and slide the halves together. Keep the flanges on each half on the outside.

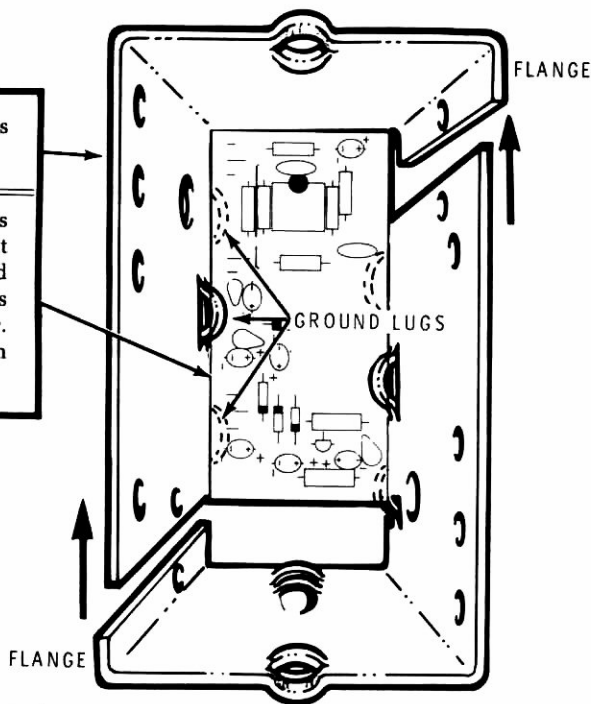

- () Fasten the two chassis halves together at the indicated corner with a long #6 solder lug and a #6 x 1/4" hex head sheet metal screw. Push a 1-5/8" length of medium heat shrink sleeving on the solder lug. See Detail 7-4A.
- () Fasten the chassis halves together at the other corner with a #6 x 1/4" hex head sheet metal screw.

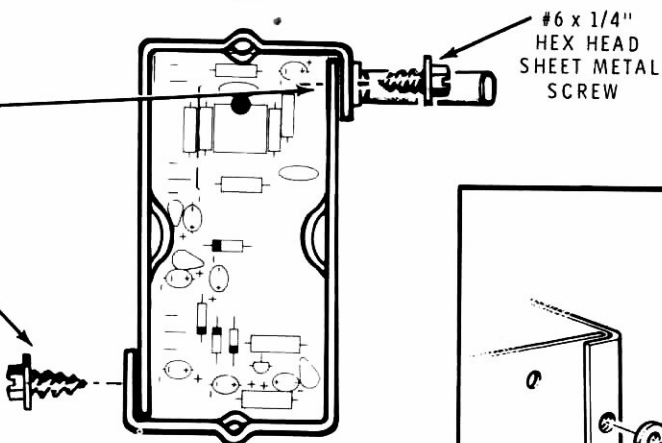

- () Now turn the assembly over, and solder the four ground lugs to the foil.

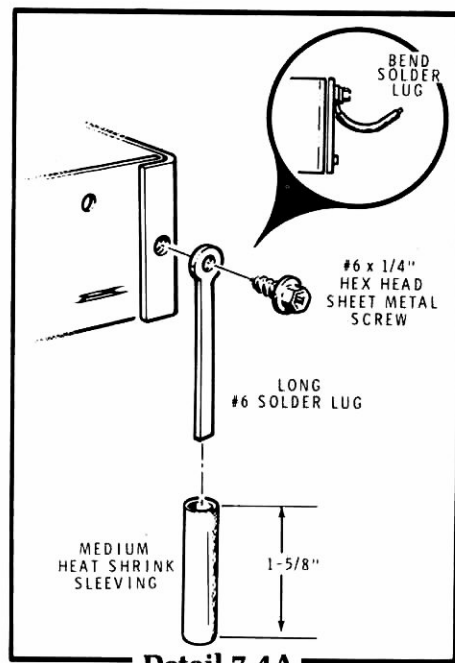
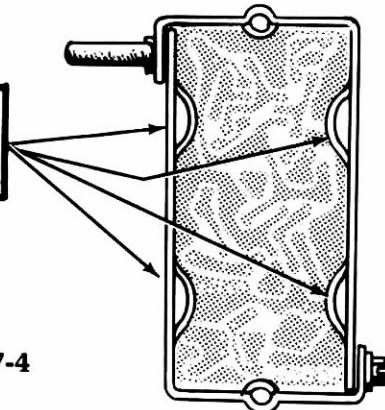

PICTORIAL 7-4

Detail 7-4A

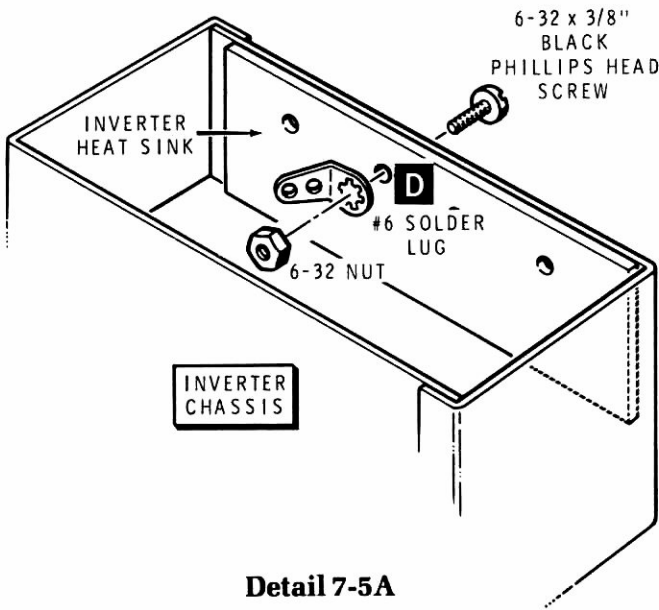

Detail 7-5A

Refer to Pictorial 7-5 (Illustration Booklet, Page 8) for the following steps.

- () Refer to the inset drawing #1 on the Pictorial and prepare the outside surface around holes C513, C514, and C515 by applying a small amount of solder. Use plenty of heat to do this. Do not get solder on the inside edge of the holes.
- () C513, C514, C515: Insert the longest end of the .001 μ F feedthrough capacitor into the holes and solder the entire skirt to the chassis. Do not bridge solder across the insulator.

CAUTION: Do not place any strain on a feedthrough capacitor when you connect a wire or a lead to them, as in the next step. To do so could damage the ceramic insulation.

- () Connect and solder the free end of the wire coming from circuit board hole +20 to feedthrough capacitor C514.

- () Refer to Detail 7-5A and loosely mount the inverter heat sink and a #6 solder lug to the chassis at D as shown. Use a 6-32 \times 3/8" black phillips head screw and a 6-32 nut. Tighten the nut only finger tight at this time. Be sure to position the heat sink so all four holes line up with the four holes in the chassis.

- () Q501: Refer to Detail 7-5B and use the following procedure to mount an MJE171 transistor (#417-819) to the chassis and heat sink:

1. Apply a thin layer of thermal compound to each side of a transistor insulator.
2. Align the mounting hole in the transistor insulator with the holes in the heat sink and chassis at Q501. Then position the insulator against the inside of the heat sink as shown in the Pictorial.
3. Position the bare metal side of the transistor toward the heat sink and insert the leads into their circuit board holes.

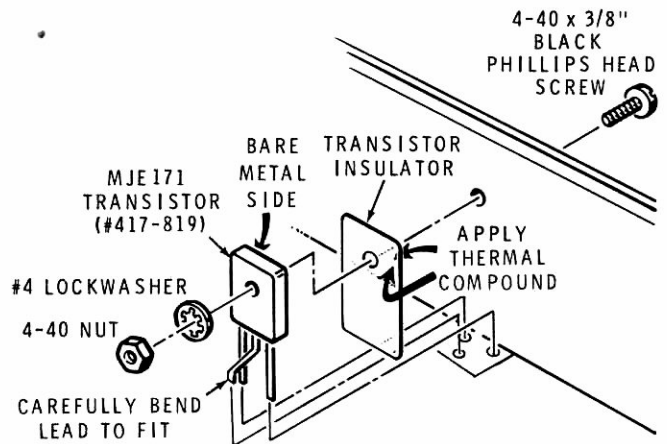

Detail 7-5B

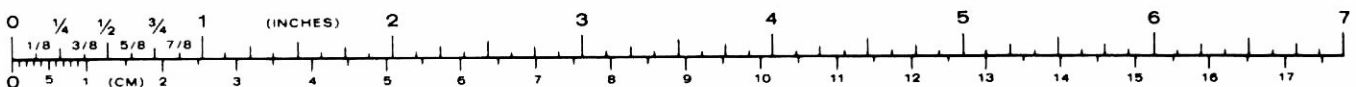

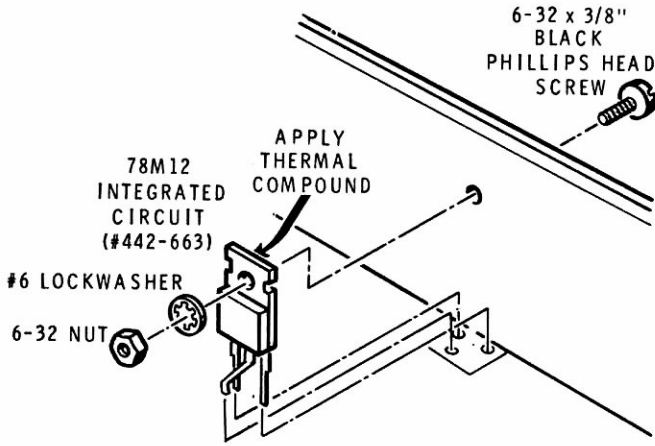

Detail 7-5C

4. Turn the chassis over and solder the leads to the foil. Cut off the excess lead lengths.

- () Tighten the hardware at D. Be sure to position the solder lug as shown in the Pictorial.
- () Cut a 7/8" length of small black sleeving. Use this sleeving in the next step.
- () L501: Cut one lead of the hash filter choke (#45-98) to 3/4" and the other lead to 1-1/8". Slide the 7/8" length of sleeving over the 1-1/8" lead. Then connect and solder this lead to circuit board hole IN. Position the choke as shown in the Pictorial. Then connect the 3/4" lead to feedthrough capacitor C513. Do not solder this connection yet.

4. Carefully bend the transistor leads so the transistor fits flat against the insulator and align the mounting holes. Use 4-40 x 3/8" black phillips head hardware to secure the transistor to the chassis.

5. Turn the chassis over and solder the transistor leads to the foil. Cut off the excess lead lengths.

- () Cut a 5/8" length of small black sleeving. Use this sleeving in the next step.
- () L502: Cut one lead of a 100 μH choke (#45-96, brn-blk-brn) to 7/8" and the other lead to 1/2". Slide the 5/8" length of sleeving over the 7/8" lead. Then connect and solder this lead to circuit board hole +12. Position the choke as shown in the Pictorial. Then connect the 1/2" lead to feedthrough capacitor C515. Do not solder this connection yet.

() Q502: Similarly, mount an MJE-181 transistor (#417-818) and insulator onto the heat sink and chassis at Q502. Then solder the leads to the foil and cut off the excess lead lengths.

() U502: Refer to Detail 7-5C and use the following procedure to mount a 78M12 integrated circuit (#442-663) to the heat sink and chassis:

1. Apply a thin layer of thermal compound to the bare metal side of the IC case.
2. Start the leads of the IC into the circuit board holes at U502. Then line up the mounting hole in the IC with the corresponding hole in the heat sink.
3. Secure the IC to the heat sink and chassis with 6-32 x 3/8" black phillips head hardware.

() C501: Connect the positive (+) marked lead of a 22 μF electrolytic capacitor to feedthrough capacitor C513 and the negative (-) lead to solder lug D. Solder the leads at feedthrough capacitor C513; but do not solder the lead to the solder lug yet.

() C512: Connect the positive (+) marked lead of a 22 μF electrolytic capacitor to feedthrough capacitor C515 and the negative (-) lead to solder lug D. Solder the leads at both connections.

() C516: Refer to inset drawing #2 on the Pictorial and connect a .05 μF ceramic capacitor from feedthrough capacitor C513 to the indicated ground lug on the side of the VCO chassis. Solder the lead only to the ground lug; the other lead will be soldered later.

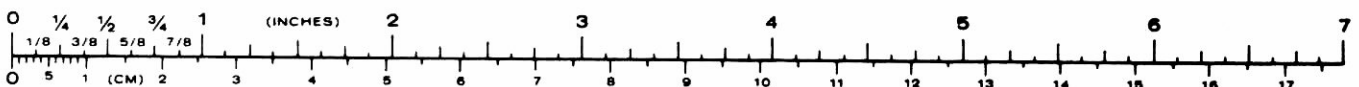

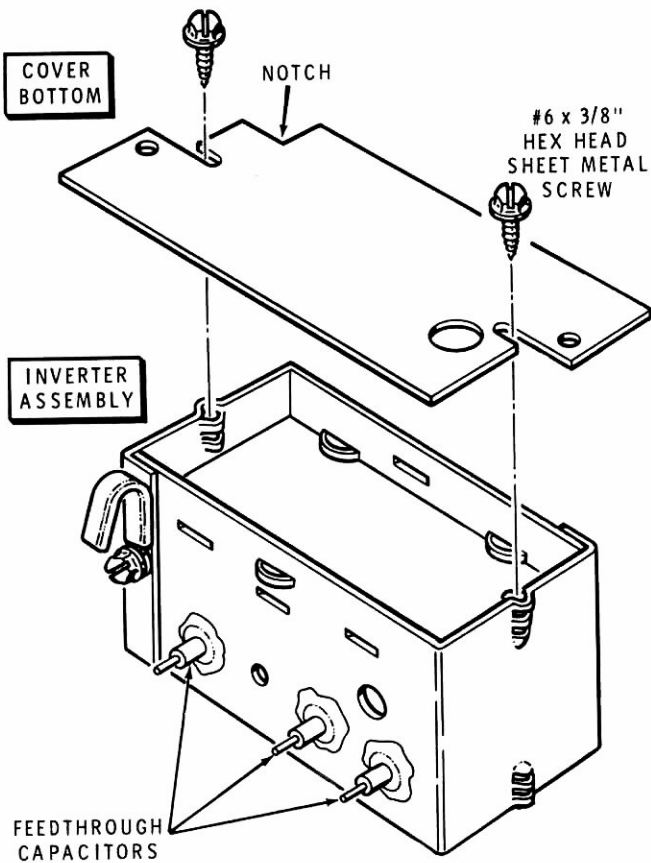

PICTORIAL 7-6

CIRCUIT BOARD CHECKOUT

Carefully inspect the foil side of the circuit board for the following most commonly-made errors:

- () Unsoldered connections. NOTE: There are 15 unused holes in the circuit board.
- () Poor solder connections.
- () Solder bridges between foil patterns.
- () Protruding leads which could touch together.

When you make the following visual checks, refer to the Pictorial where the part was installed and check it against the installation instructions.

- () Check the transistors and ICs for the proper installation.

- () Check the electrolytic capacitors for the correct position of the positive (+) lead.
- () Check the diodes for proper installation.
- () Refer to Pictorial 7-6 and use the following procedure to mount the bottom cover onto the inverter assembly:

1. Position the inverter assembly bottom-side-up as shown in the Pictorial. Note the locations of the feedthrough capacitors.
2. Position the bottom cover as shown in the Pictorial. Then use two #6 × 3/8" hex head sheet metal screws to mount the cover onto the assembly.

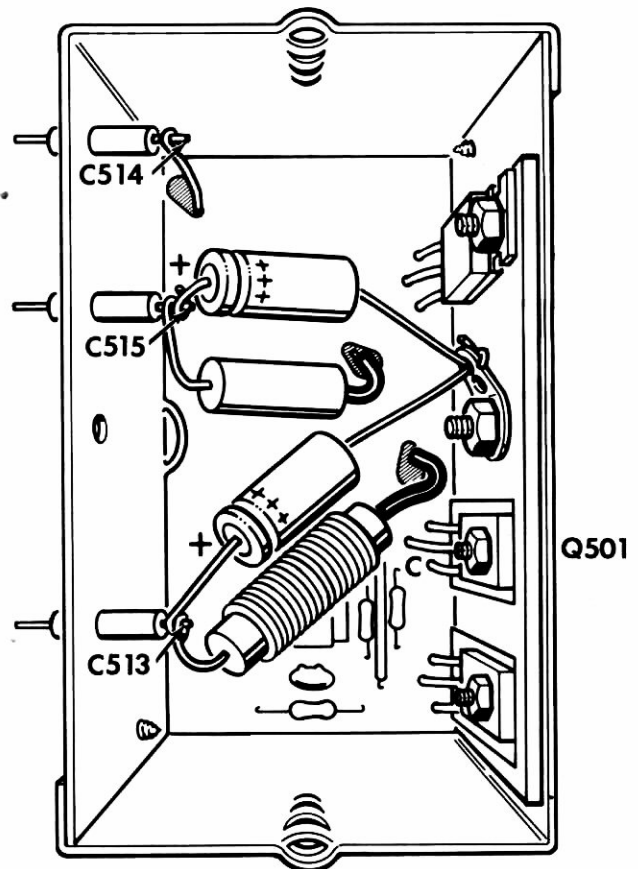

PICTORIAL 7-7

INITIAL TESTS

Refer to Pictorial 7-7 for the following steps.

- () Connect the common ohmmeter lead to the inverter chassis.
- () Set the ohmmeter to $R \times 1000$.

Use the positive ohmmeter lead to check for the proper readings at the following points:

- () Inner end of feedthrough capacitor C513. Approximately 2000Ω . Check C501, C502, U501, D501.
- () Inner end of feedthrough capacitor C514. Approximately 1000Ω . Check U502, C509.

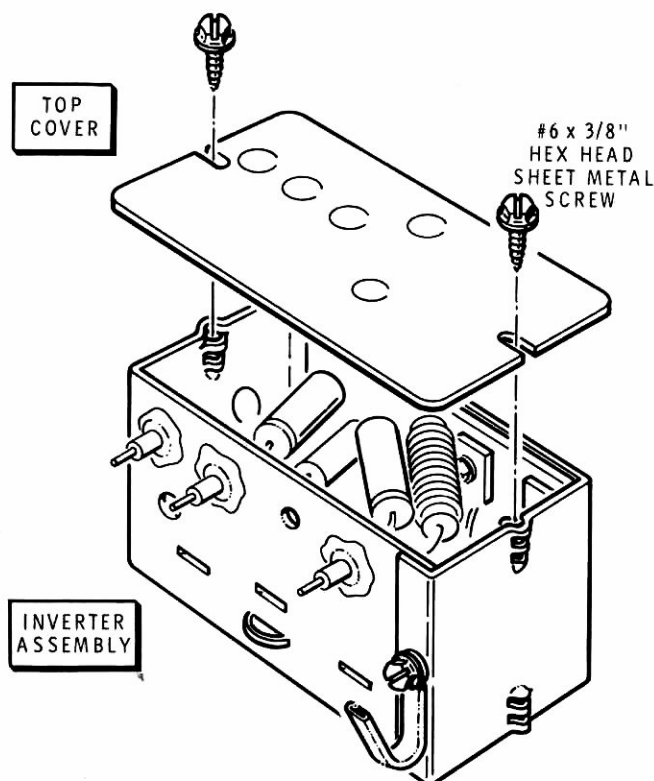

PICTORIAL 7-8

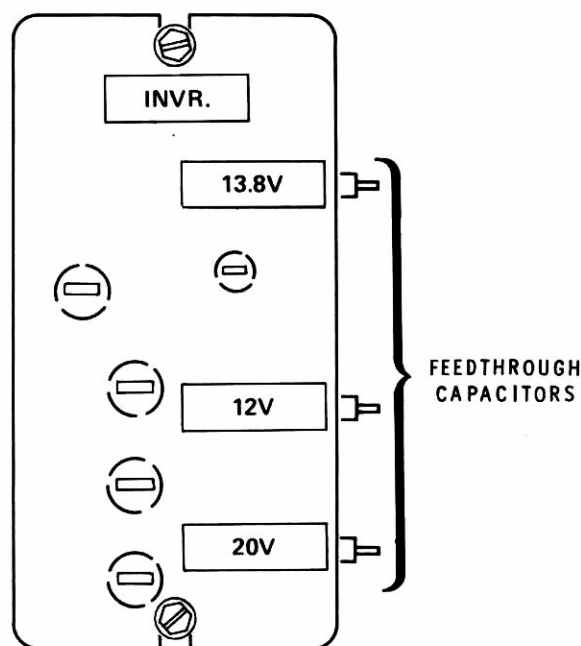

Detail 7-8A

- () Inner lead of feedthrough capacitor C515. $10 \text{ k}\Omega$ or greater. Check U503, C512.
- () Check the collector (C) lead of transistor Q501. 2000Ω to $10 \text{ k}\Omega$. Check Q501, Q502, C505.

This completes the "Initial Tests" of the inverter assembly. Proceed to "Assembly Continued".

ASSEMBLY CONTINUED

- () Refer to Pictorial 7-8 and mount the top cover to the inverter assembly as shown. Use two #6 x 3/8" hex head sheet metal screws.
- () Position the inverter assembly as shown in Detail 7-8A (note the locations of the feedthrough capacitors). Then apply labels from the label sheet to the top cover as shown.

This completes the assembly and "Initial Tests" of your inverter assembly. Set the assembly aside until it is called for during the assembly of the chassis. Proceed to "IF Circuit Board".

IF CIRCUIT BOARD

PARTS LIST

- () Refer to the Pack Index Sheet and locate Pack #8. Then remove the parts from this pack and check each part against the following list. The key numbers correspond to the numbers on the "IF Circuit Board Parts Pictorial" (Illustration Booklet, Page 8). Return any part that is packed in an individual envelope, with the part number on it, back into its envelope until that part is called for in a step. Do not throw away

any packing material until you account for all the parts.

To order a replacement part, always include the PART NUMBER. Use the Parts Order Form furnished with this kit. If a Parts Order Form is not available, refer to "Replacement Parts" inside the rear cover of this Manual. For prices, refer to the separate "Heath Parts Price List."

KEY No.	HEATH Part No.	QTY.	DESCRIPTION	CIRCUIT Comp. No.
---------	----------------	------	-------------	-------------------

RESISTORS

NOTES:

- Resistors may be packed in more than one envelope. Open all of the resistor envelopes in this pack before you check the resistors against the following Parts List.
- The following resistors are rated at 1/4-watt and have a tolerance of 5% (fourth band gold) unless otherwise noted. 1% is indicated by a brown fifth color band (unless they have their values and tolerance printed on them).

A1	6-510-12	1	51 Ω (grn-brn-blk)	R1154
A1	6-101-12	7	100 Ω (brn-blk-brn)	R1105, R1113, R1116, R1122, R1123, R1125, R1128
A1	6-221-12	1	220 Ω (red-red-brn)	R1139
A1	6-271-12	1	270 Ω (red-viol-brn)	R1114
A1	6-331-12	3	330 Ω (org-org-brn)	R1112, R1121, R1126
A1	6-391-12	1	390 Ω (org-wht-brn)	R1106

KEY No.	HEATH Part No.	QTY.	DESCRIPTION	CIRCUIT Comp. No.
---------	----------------	------	-------------	-------------------

Resistors (Cont'd)

A1	6-471-12	2	470 Ω (yel-viol-brn)	R1119, R1127
A1	6-102-12	2	1000 Ω (brn-blk-red)	R1134, R1151
A1	6-152-12	1	1500 Ω (brn-grn-red)	R1104
A1	6-182-12	2	1800 Ω (brn-gry-red)	R1108, R1145
A1	6-332-12	2	3300 Ω (org-org-red)	R1117, R1132
A1	6-472-12	1	4700 Ω (yel-viol-red)	R1107
A1	6-103-12	11	10 kΩ (brn-blk-org)	R1103, R1109, R1111, R1129, R1137, R1143, R1146, R1147, R1148, R1149, R1152
A1	6-123-12	1	12 kΩ (brn-red-org)	R1138
A1	6-153-12	1	15 kΩ (brn-grn-org)	R1118
A1	6-183-12	1	18 kΩ (brn-gry-org)	R1136
A1	6-223-12	1	22 kΩ (red-red-org)	R1131
A1	6-333-12	1	33 kΩ (org-org-org)	R1115
A1	6-184-12	1	180 kΩ (brn-gry-yel)	R1133
A1	6-474-12	1	470 kΩ (yel-viol-yel)	R1102
A1	6-105-12	3	1 MΩ (brn-blk-gm)	R1124, R1141, R1142
A1	6-155-12	1	1.5 MΩ (brn-grn-grn)	R1153
A1	6-1005-12	1	10 MΩ, 1% (brn-blk-blk-gm)	R1135

KEY No.	HEATH Part No.	QTY.	DESCRIPTION	CIRCUIT Comp. No.	KEY No.	HEATH Part No.	QTY.	DESCRIPTION	CIRCUIT Comp. No.
CAPACITORS					TRANSISTORS — INTEGRATED CIRCUIT (IC)				
Ceramic					NOTES:				
B1	21-78	2	5 pF	C1119, C1126	1.	Transistors and integrated circuits may be marked for identification in any of the following four ways:			
B1	21-147	1	47 pF	C1131	a.	Part number.			
B1	21-171	1	680 pF	C1127	b.	Type number. (On integrated circuits, this refers only to the numbers; the letters may be different or missing.)			
B1	21-140	1	.001 μ F (1000 pF)	C1121	c.	Part number and type number.			
B1	21-176	20	.01 μ F	C1101, C1105, C1106, C1107, C1108, C1111, C1112, C1113, C1114, C1115, C1116, C1117, C1123, C1124, C1125, C1129, C1136, C1137, C1138, C1139	d.	Part number with a type number other than the one listed.			
B1	21-143	1	.05 μ F	C1134	2.	Some of the ICs may be packed in conductive foam. Do not remove these ICs from the foam until a step directs you to install them.			
B1	21-95	1	.1 μ F	C1132	D1	417-241	1	EL131 transistor	Q1107
Electrolytic					D1	417-801	5	MPSA20 transistor	Q1102, Q1108, Q1109, Q1111, Q1112
B2	25-925	1	4.7 μ F	C1133	D1	417-172	3	MPS6521 transistor	Q1104, Q1105, Q1106
B2	25-931	2	10 μ F	C1122, C1128	D2	417-863	2	MFE131 transistor	Q1101, Q1103
B2	25-883	1	47 μ F	C1135	D3	442-99	1	CD4016AE IC	U1101
INDUCTORS					MISCELLANEOUS				
C1	40-1726	1	7 μ H toroid	L1101	E1	10-1071	1	5000 Ω (5 k Ω) control	R1144
C2	45-604	1	100 μ H choke (brn-blk-brn)	L1103	E2	56-20	2	1N295A diode (red-wht-grn)	D1101, D1102
C3	52-190	4	8.83 MHz IF transformer	T1101, T1102, T1103, T1104		85-2685-2	1	IF circuit board	
					E3	206-1332	1	Coil shield	Y1102
					E4	404-641	1	8.83 MHz crystal filter	P1103, P1105
					E5	432-969	3	5-pin plug	P1101, P1102, P1104, P1106, P1107
					E6	432-1265	3	3-pin plug	S1101
					E7	434-146	1	Phono socket	
					E8	434-298	1	14-pin IC socket	
					E9	475-10	3	Ferrite bead	

STEP-BY-STEP ASSEMBLY

START 

Position the circuit board as shown.

() R1129: 10 k Ω (brn-blk-org).

() R1126: 330 Ω (org-org-brn).

() R1132: 3300 Ω (org-org-red).

() R1116: 100 Ω (brn-blk-brn).

() R1121: 330 Ω (org-org-brn).

() R1123: 100 Ω (brn-blk-brn).

() R1125: 100 Ω (brn-blk-brn).

() R1131: 22 k Ω (red-red-org).

() Solder the leads to the foil and cut off the excess lead lengths.

() R1118: 15 k Ω (brn-grn-org).

() R1117: 3300 Ω (org-org-red).

() R1137: 10 k Ω (brn-blk-org).

NOTE: The following resistor may have the value printed on it instead of the color code.

() R1135: 10 M Ω , 1% (brn-blk-blk-grn).

() 3/4" white solid wire.

Install the following ferrite beads as shown in Detail 8-1A. Use 7/8" small bare wire.

() Ferrite bead.

() Ferrite bead.

() R1154: 51 Ω (grn-brn-blk).
NOTE: Although this component may not be shown on your circuit board, holes are provided so you can install it at the location shown.

() R1104: 1500 Ω (brn-grn-red).

() Solder the leads to the foil and cut off the excess lead lengths.

CONTINUE 

() R1146: 10 k Ω (brn-blk-org).

() R1145: 1800 Ω (brn-gry-red).

() R1149: 10 k Ω (brn-blk-org).

() R1151: 1000 Ω (brn-blk-red).

() R1148: 10 k Ω (brn-blk-org).

() R1115: 33 k Ω (org-org-org).

() R1113: 100 Ω (brn-blk-brn).

() R1128: 100 Ω (brn-blk-brn).

() Solder the leads to the foil and cut off the excess lead lengths.

() R1112: 330 Ω (org-org-brn).

() R1109: 10 k Ω (brn-blk-org).

() R1108: 1800 Ω (brn-gry-red).

() R1102: 470 k Ω (yel-viol-yel).
NOTE: Your circuit board may be marked L1102.

() R1105: 100 Ω (brn-blk-brn).

() L1103: 100 μ H choke (#45-604, brn-blk-brn).

() R1107: 4700 Ω (yel-viol-red).

() NOTE: Do not install a component at this location, which may be marked 47 K.

() R1103: 10 k Ω (brn-blk-org).

() Solder the leads to the foil and cut off the excess lead lengths.

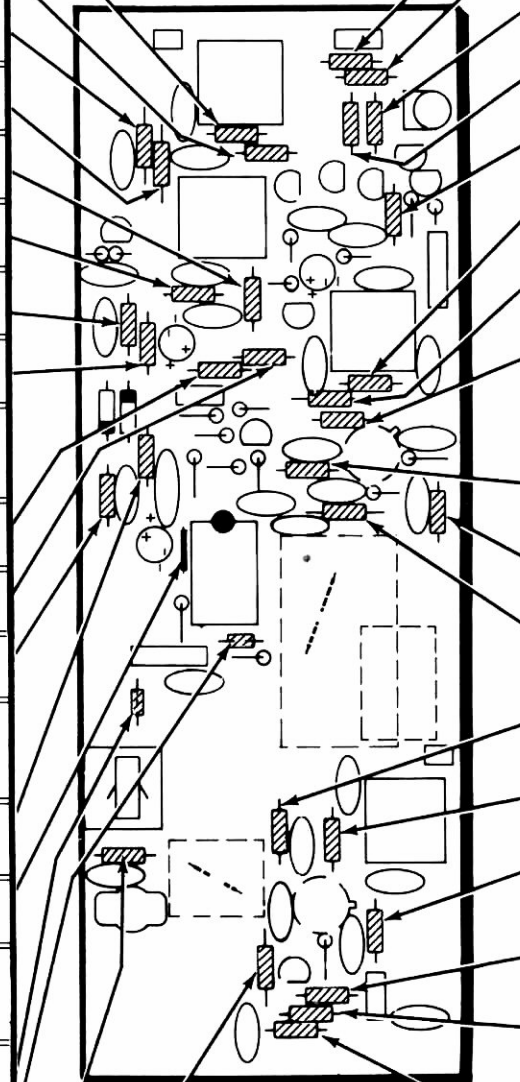

PICTORIAL 8-1

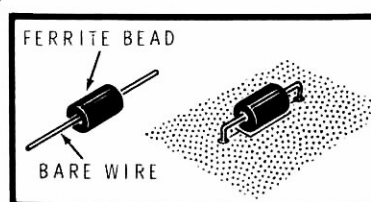

Detail 8-1A

START

Prepare two 2-pin plugs from a 5-pin plug as shown.

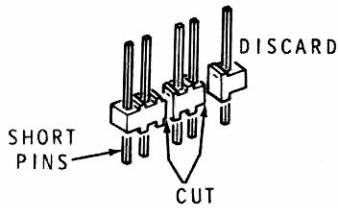

NOTE: To install the plugs, insert the short lugs and solder them to the foil.

P1107: 2-pin plug.

P1106: 3-pin plug.

P1105: 5-pin plug.

P1104: 3-pin plug.

P1103: 5-pin plug.

P1102: 2-pin plug.

P1101: 3-pin plug.

S1101: Phono socket. Install the socket either way. Solder the two tabs and center lug to the foil. Cut off the excess lengths.

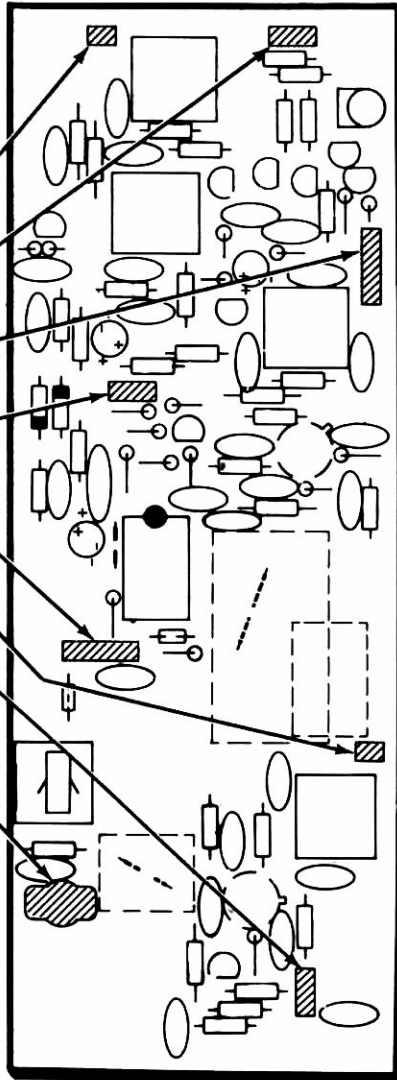

PICTORIAL 8-2

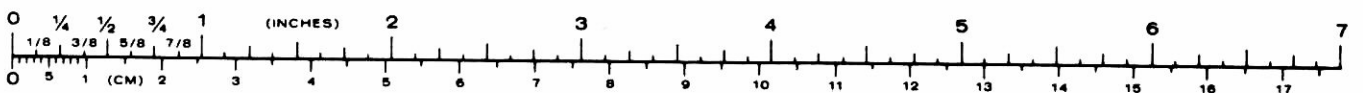

START ↙

NOTE: When you install each of the following transistors, position the flat on the transistor over the outline of the flat on the circuit board. Then insert the leads into the circuit board holes and solder them to the foil. Cut off the excess lead length.

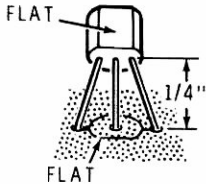

() Q1106: MPS6521 (#417-172).

() Q1104: MPS6521 (#417-172).

() Q1107: EL131 (#417-241).

NOTE: To install each of the following transistors, match the tab on the transistor with the tab outline on the board. Solder the leads to the foil and cut off the excess lead lengths. If there is a shorting wire around the transistor leads, remove and discard it.

MAY OR MAY NOT HAVE A SHORTING WIRE

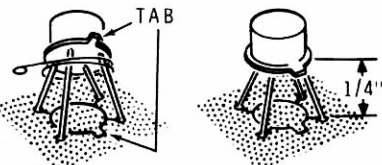

() Q1103: MFE131 (#417-863).

() Q1101: MFE131 (#417-863).

() Q1102: MPSA20 (#417-801).

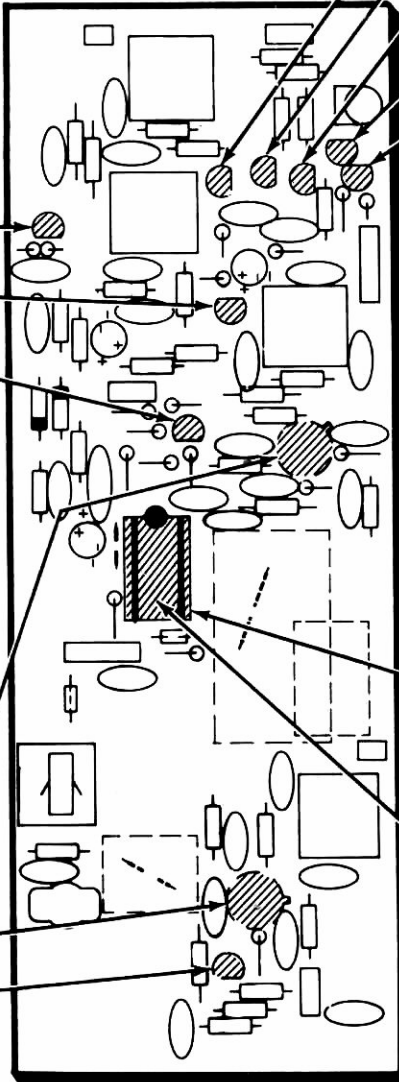

CONTINUE ↘

() Q1105: MPS6521 (#417-172).

() Q1112: MPSA20 (#417-801).

() Q1109: MPSA20 (#417-801).

() Q1108: MPSA20 (#417-801).

() Q1111: MPSA20 (#417-801).

NOTE: When you install the IC socket in the following step, be sure the pins are straight. Insert the pins into the holes. The index mark on the circuit board must still be visible after it is installed. Solder the pins to the foil as you install each socket and cut off any excess pin lengths.

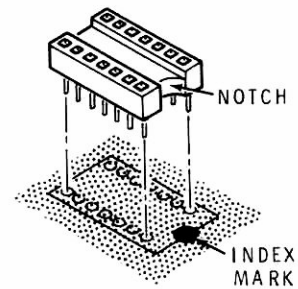

() 14-pin IC socket.

Refer to the Integrated Circuit Installation on Page 35 and install the following IC.

() U1101: CD4016AE (#442-99).

PICTORIAL 8-3

START

() C1125: .01 μ F ceramic.

() C1126: 5 pF ceramic.

() C1123: .01 μ F ceramic.

() C1124: .01 μ F ceramic.

() C1138: .01 μ F ceramic.

() C1129: .01 μ F ceramic.

() C1131: 47 pF ceramic.

() Solder the leads to the foil and cut off the excess lead lengths.

NOTE: When you install electrolytics, be sure to match the plus (+) mark on the capacitor with the plus (+) mark on the circuit board, or match the negative (-) mark on the capacitor with the negative (-) mark on the circuit board.

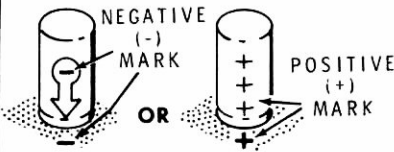

() C1128: 10 μ F electrolytic.

() C1134: .05 μ F ceramic.

() C1132: .1 μ F ceramic.

() C1133: 4.7 μ F electrolytic.

() C1101: .01 μ F ceramic.

() L1101: 7 μ H toroid (#40-1726).

() C1139: .01 μ F ceramic.

() Solder the leads to the foil and cut off the excess lead lengths.

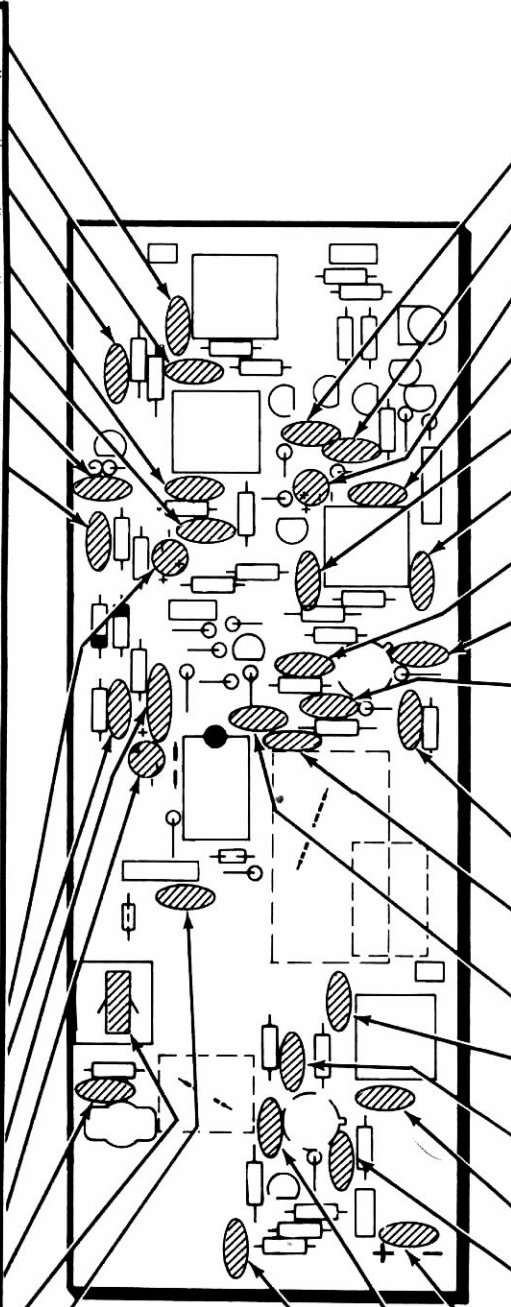

PICTORIAL 8-4

CONTINUE

() C1127: 680 pF ceramic.

() C1136: .01 μ F ceramic.

() C1122: 10 μ F electrolytic.

() C1121: .001 μ F ceramic.

() C1119: 5 pF ceramic.

() C1117: .01 μ F ceramic.

() C1115: .01 μ F ceramic.

() C1116: .01 μ F ceramic.

() C1114: .01 μ F ceramic.

() Solder the leads to the foil and cut off the excess lead lengths.

() C1113: .01 μ F ceramic.

NOTE: Do not install a component at this location, which may be marked 20.

() C1137: .01 μ F ceramic.

() C1112: .01 μ F ceramic.

() C1107: .01 μ F ceramic.

() C1108: .01 μ F ceramic.

() C1111: .01 μ F ceramic.

() C1135: 47 μ F electrolytic. Be sure to install this capacitor with the positive (or negative) mark as shown on this Pictorial. **NOTE:** Your circuit board may be marked .01.

() C1106: .01 μ F ceramic.

() C1105: .01 μ F ceramic.

() Solder the leads to the foil and cut off the excess lead length.

START ↘

- () R1146: 5000 Ω (5k Ω) control (#10-1071). Form the leads to fit the circuit board holes and position the body of the control over the outline. Solder the lugs to the foil and cut off the excess lugs.

NOTE: Mount the following resistors vertically where this is indicated by the outlines on the circuit board.

- () R1133: 180 k Ω (brn-gry-yel).

- () R1134: 1000 Ω (brn-blk-red).

NOTE: DIODES MAY BE SUPPLIED IN ANY OF THE FOLLOWING SHAPES. ALWAYS POSITION THE BANDED END AS SHOWN ON THE CIRCUIT BOARD.

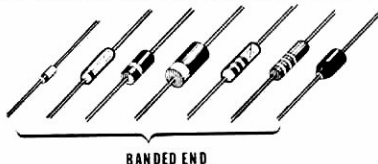

- () D1101: 1N295A (#56-20).

- () D1102: 1N295A (#56-20).

- () R1124: 1 M Ω (brn-blk-grn).
NOTE: Your circuit board may be marked 100 K.

- () R1136: 18 k Ω (brn-gry-org).

- () R1139: 220 Ω (red-red-brn).

- () R1142: 1 M Ω (brn-blk-grn).
NOTE: Your circuit board may be marked 100 K.

- () R1141: 1 M Ω (brn-blk-grn).

- () Solder the leads to the foil and cut off the excess lead lengths.

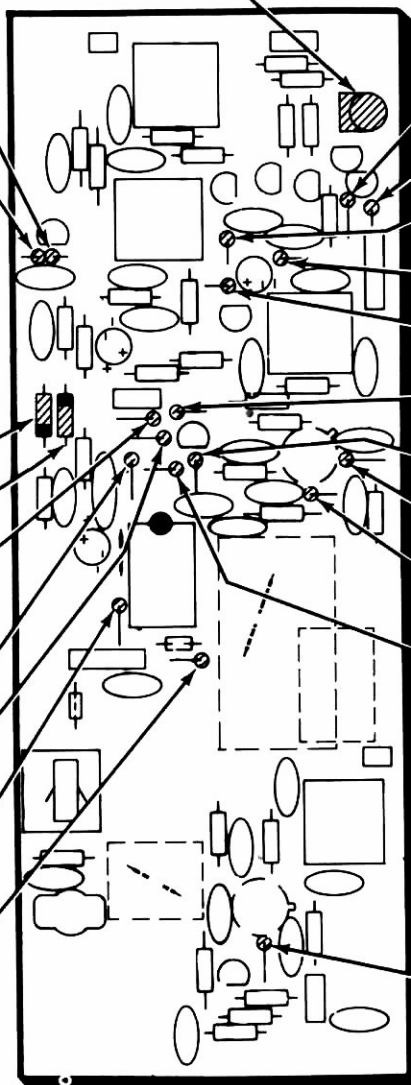
**CONTINUE** ↘

- () R1147: 10 k Ω (brn-blk-org).

- () R1143: 10 k Ω (brn-blk-org).

- () R1127: 470 Ω (yel-viol-brn).

- () R1122: 100 Ω (brn-blk-brn).

- () R1119: 470 Ω (yel-viol-brn).

- () R1138: 12 k Ω (brn-red-org).

- () R1152: 10 k Ω (brn-blk-org).

- () R1114: 270 Ω (red-viol-brn).

- () R1111: 10 k Ω (brn-blk-org).

- () Ferrite bead. Install it with a 1" length of bare wire as shown.

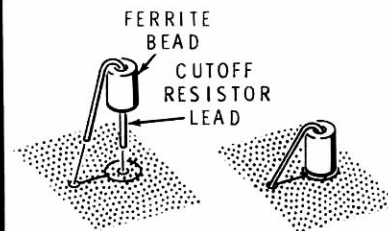

- () R1106: 390 Ω (org-wht-brn).

- () Solder the leads to the foil and cut off the excess lead lengths.

PICTORIAL 8-5

START

NOTE: The following transformers and filter can only be installed one way. Solder the lugs and tabs to the foil and cut off the excess length.

() T1104: 8.83 MHz IF transformer (#52-190).

() T1103: 8.83 MHz IF transformer (#52-190).

() T1102: 8.83 MHz IF transformer (#52-190).

() T1101: 8.83 MHz IF transformer (#52-190).

() Coil shield. Solder the tabs to the foil and cut off any excess tab length.

NOTE: If you purchased the Model HWA-5400-2 optional filter, complete Step 1. If you did not purchase it, complete Step 2.

1. () Y1101: Optional filter (#404-640). This filter may be installed either way in the circuit board.

2. () 3/4" bare wire. Solder the wire to the foil and cut off the excess length.

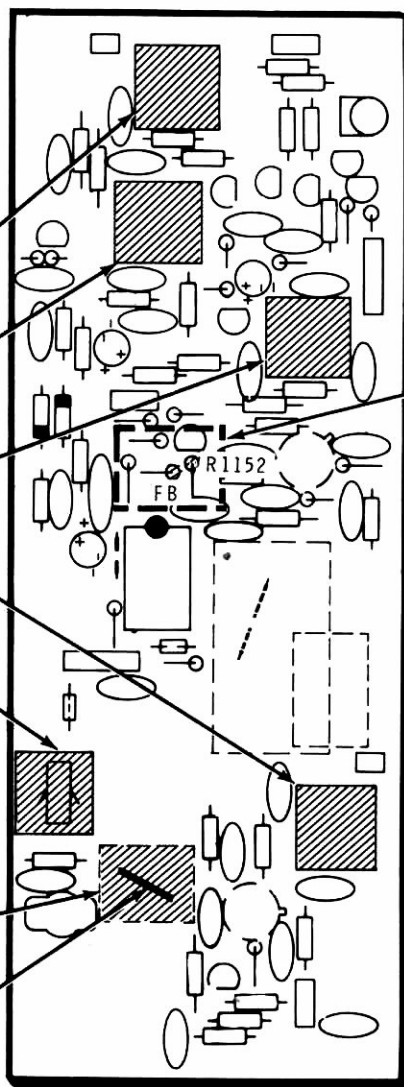

() R1153: Cut one lead of a 1.5 MΩ (brn-grn-grn) resistor to 1/4" and the other lead to 3/4". Then form the leads as shown in Detail 8-6A and connect the 1/4" lead to lead coming from the top of resistor R1152 (10 kΩ, brn-blk-org). Connect the 3/4" lead to the lead coming from the top of the nearby ferrite bead (FB). Solder both connections.

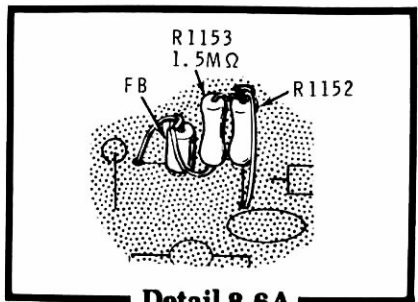

PICTORIAL 8-6

Detail 8-6A

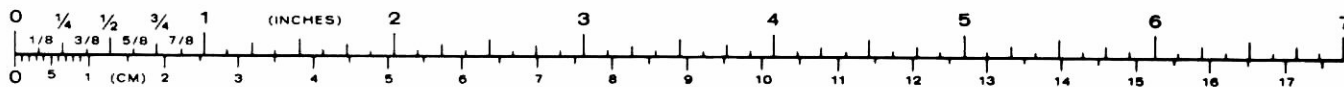

START 

NOTE: You may have received either of two types of 8.83 MHz (#404-641) crystal filters. If you have received the large one, complete Step 1. If you have received the small one, complete Steps 2 and 3.

1. () Y1102: Crystal filter. Do not install the jumper wire "J". The filter may be installed either way in the circuit board. Disregard any "in" and "out" markings on the filter.

OR

2. () 1" bare wire. Solder the wire to the foil and cut off the excess length.

3. () Y1102: Crystal filter. The filter may be installed either way in the circuit board.

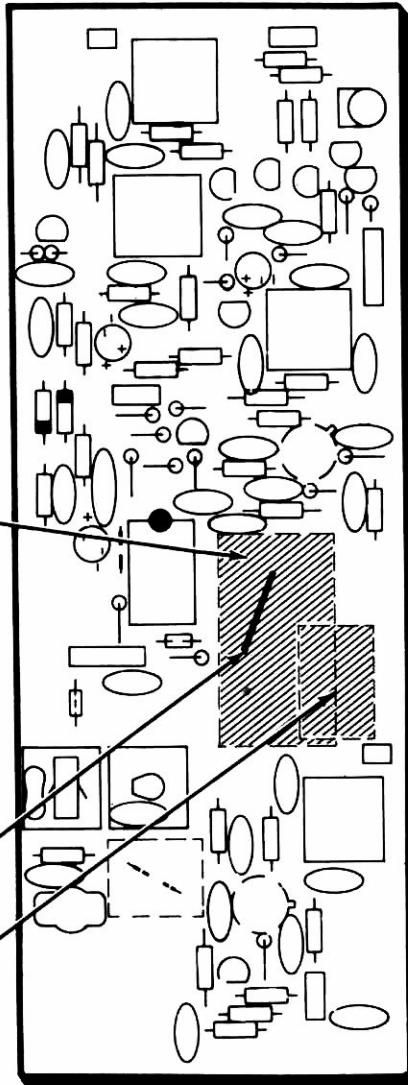
**PICTORIAL 8-7****CIRCUIT BOARD CHECKOUT**

Carefully inspect the circuit board for the following condition.

- () Unsoldered connections.
- () Poor solder connections.
- () Solder bridges between foil patterns.
- () Protruding leads which could touch together.
- () Transistors for the proper installation.
- () Diodes for the proper installation.
- () Integrated circuit for the correct installation.
- () Electrolytic capacitors for the correct position of the positive (+) lead.
- () Be sure you removed the shorting wires from transistors Q1101 and Q1103.

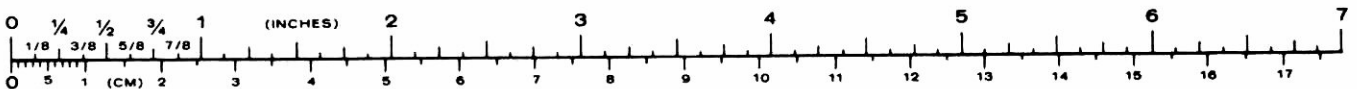

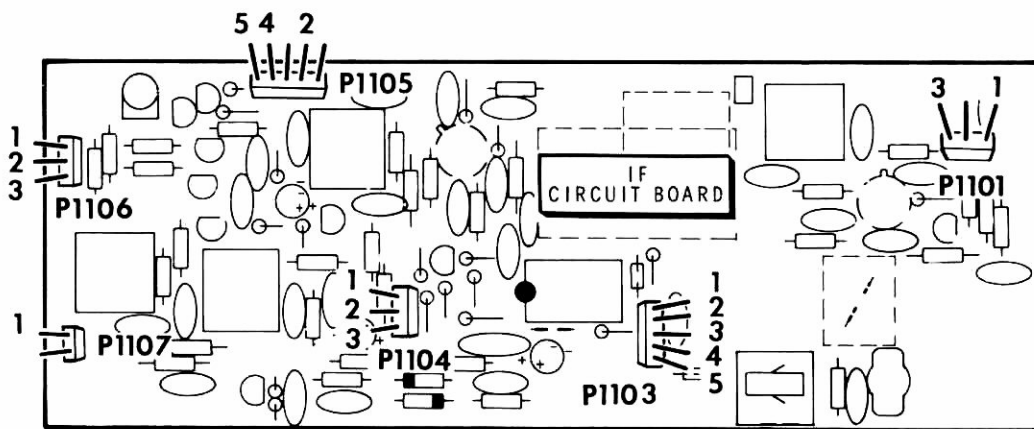

PICTORIAL 8-8

INITIAL TESTS

NOTE: In the following steps, the setting of your ohmmeter is indicated in parentheses, "(R × 10K)" for example, because meaningful readings cannot be taken using a single range. Be sure to zero your ohmmeter each time you change its range.

Refer to Pictorial 8-8 for the following steps.

- () Connect the common ohmmeter lead to a ground point on the IF circuit board foil. NOTE: A convenient point is the bare foil at any of the mounting holes.

Use the positive ohmmeter probe to check the IF circuit board plugs for the following readings. Note that, as on the previous circuit board, the steps are abbreviated.

NOTE: Do not change ohmmeter ranges unless a step directs you to do so.

- () P1101-1. 10 kΩ or greater. Check Q1102, C1105, C1135. (R × 1000).
- () P1101-3. Infinity. Check C1108, L1103, T1101.
- () P1103-1. 5000 Ω to 15 kΩ. Check U1101C.
- () P1103-3. 200 kΩ or greater. Check U1101A. (R × 100K).
- () P1103-4. 50 kΩ to 100 kΩ. Check U1101B. (R × 10K).
- () P1103-5. 5000 Ω to 10 kΩ. Check C1132, D1102, U1101B. (R × 1000).
- () P1104-1. 1000 Ω to 2000 Ω. Check Q1107. (R × 100).
- () P1104-2. 600 Ω to 1000 Ω. Check Q1107, C1138.
- () P1104-3. 5000 Ω to 10 kΩ. Check Q1104, Q1106. (R × 1000).
- () P1105-2. Infinity. Check C1121. (R × 10K).
- () P1105-4. 50 kΩ to 100 kΩ. Check C1136, Q1108, Q1109, Q1111.
- () P1105-5. 50 kΩ to 100 kΩ. Check Q1108, Q1109, Q1111.
- () P1106-1. 50 kΩ to 100 kΩ. Check Q1109, Q1112.
- () P1106-2. Infinity. Check Q1112.
- () P1106-3. 50 kΩ to 100 kΩ. Check Q1108.
- () P1107-1. 10 Ω or less. Check T1104. (R × 1).

This completes the "Initial Tests" of your IF circuit board. Set the circuit board aside until it is called for during the assembly of the chassis.

BFO CIRCUIT BOARD

PARTS LIST

() Refer to the Pack Index Sheet and locate Pack #9. Then remove these parts from this pack and check each part against the following list. The key numbers correspond to the numbers on the "BFO Circuit Board Parts Pictorial" (Illustration Booklet, Page 9). Return any part that is packed in an individual envelope, with the part number on it, back into its envelope until that part is called for in a step. Do not throw away

any packing material until you account for all the parts.

To order a replacement part, always include the PART NUMBER. Use the Parts Order Form furnished with this kit. If a Parts Order Form is not available, refer to "Replacement Parts" inside the rear cover of this Manual. For prices, refer to the separate "Heath Parts Price List."

KEY No.	HEATH Part No.	QTY.	DESCRIPTION	CIRCUIT Comp. No.
---------	----------------	------	-------------	-------------------

RESISTORS

NOTES:

- Resistors may be packed in more than one envelope. Open all of the resistor envelopes in this pack before you check the resistors against the following Parts List.
- The following resistors are rated at 1/4-watt and have a tolerance of 5% (fourth band gold) unless otherwise noted.

A1	6-560-12	1	56 Ω (grn-blu-blk)	R815
A1	6-101-12	1	100 Ω (brn-blk-brn)	R822
A1	6-181-12	1	180 Ω (brn-gry-brn)	R825
A1	6-221-12	1	220 Ω (red-red-brn)	R832
A1	6-331-12	2	330 Ω (org-org-brn)	R828, R838
A1	6-561-12	1	560 Ω (grn-blu-brn)	R833

KEY No.	HEATH Part No.	QTY.	DESCRIPTION	CIRCUIT Comp. No.
---------	----------------	------	-------------	-------------------

Resistors (Cont'd.)

A1	6-102-12	1	1000 Ω (brn-blk-red)	R826
A1	6-152-12	1	1500 Ω (brn-grn-red)	R835
A1	6-222-12	2	2200 Ω (red-red-red)	R824, R842
A1	6-272-12	1	2700 Ω (red-viol-red)	R836
A1	6-332-12	4	3300 Ω (org-org-red)	R802, R805, R813, R818
A1	6-103-12	14	10 k Ω (brn-blk-org)	R801, R803, R804, R806, R807, R808, R811, R812, R814, R816, R819, R821, R840, R843
A1	6-153-12	2	15 k Ω (brn-grn-org)	R827, R831
A1	6-223-12	3	22 k Ω (red-red-org)	R817, R829, R839
A1	6-473-12	1	47 k Ω (yel-viol-org)	R841

KEY No.	HEATH Part No.	QTY.	DESCRIPTION	CIRCUIT Comp. No.	KEY No.	HEATH Part No.	QTY.	DESCRIPTION	CIRCUIT Comp. No.
CONTROLS					DIODES				
B1	10-1139	1	100 Ω	R823	E1	56-24	2	1N458	D808, D811
B1	10-1141	2	1000 Ω (1 kΩ)	R834, R837	E1	56-56	9	1N4149	D801, D802, D803, D805, D806, D807, D812, D813, D814
CAPACITORS									
Mica									
C1	20-183	1	120 pF	C811	E2	56-640	1	MV2110	D809
C1	20-178	1	160 pF	C819	E1	56-19	1	VR-9.1	D804
C1	20-120	1	220 pF	C812	TRANSISTORS				
Ceramic					NOTE: Transistors may be marked for identification in any of the following four ways:				
C2	21-181	2	7.7 pF	C817, C821	1. Part number.				
C2	21-22	1	220 pF	C805	2. Type number.				
C2	21-17	1	270 pF	C806	3. Part number and type number.				
C2	21-171	1	680 pF	C807	4. Part number with a type number other than the one listed.				
C3	21-761	10	.01 μF (103) glass	C801, C802, C804, C808, C813, C814, C815, C818, C823, C824	F1	417-801	5	MPSA20	Q801, Q803, Q806, Q807, Q811
C2	21-143	1	.05 μF	C809	F1	417-134	1	MPS6520	Q813
Other Capacitors					F1	417-172	1	MPS6521	Q814
C4	25-931	1	10 μF electrolytic	C803	F1	417-201	6	X29A829	Q802, Q804, Q805, Q808, Q809, Q812
C5	31-71	2	3.2-18 pF ceramic trimmer (blue screw)	C816, C822	MISCELLANEOUS				
INDUCTORS					85-2686-3 1 BFO circuit board				
D1	40-2075	1	.44 μH coil	L801	G1	258-5	1	Spring contact	Y801
D2	40-2064	1	22 μH toroid	L804	G2	404-638	1	8.8286 MHz crystal	Y802
D3	45-604	5	100 μH choke (brn-blk-brn)	L802, L803, L805, L806, L807	G2	404-639	1	8.8314 MHz crystal	P805
					G3	432-969	1	5-pin plug	P801, P802, P803, P804
					G4	432-1265	4	3-pin plug	

STEP-BY-STEP ASSEMBLY

START

- () Locate the BFO circuit board and position it lettered side up as shown.

NOTE: When you install a diode, always match the band on the diode with the band mark on the circuit board. A DIODE WILL NOT WORK PROPERLY IF IT IS INSTALLED BACKWARDS. See Detail 9-1A.

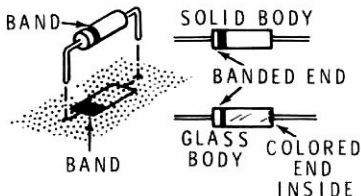

CAUTION: ALWAYS POSITION THE BANDED END OF A DIODE AS SHOWN ON THE CIRCUIT BOARD.

If your diode has a solid body, the band is clearly defined. If your diode has a glass body, do not mistake the colored end inside the diode for the banded end. Look for a band painted on the outside of the glass.

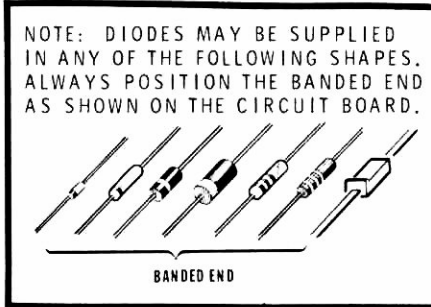

Detail 9-1A

- () D808: 1N458 diode (#56-24).
- () D811: 1N458 diode (#56-24).
- () D813: 1N4149 diode (#56-56).
- () D814: 1N4149 diode (#56-56).
- () D812: 1N4149 diode (#56-56).
- () D802: 1N4149 diode (#56-56).
- () D801: 1N4149 diode (#56-56).
- () D803: 1N4149 diode (#56-56).
- () D805: 1N4149 diode (#56-56).
- () D804: VR-9.1 diode (#56-19).
- () Solder the leads to the foil and cut off the excess lead lengths.

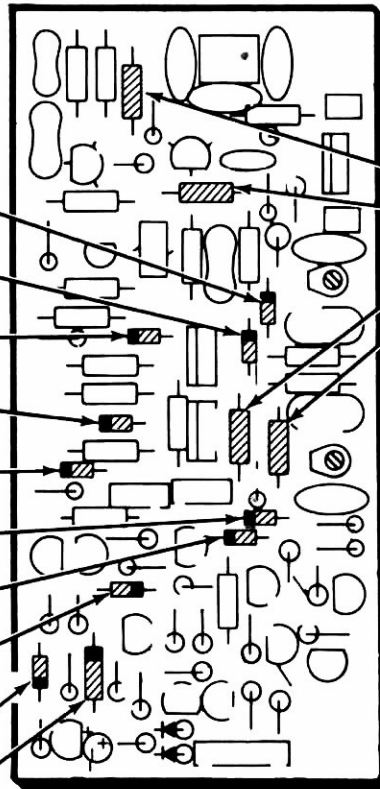

PICTORIAL 9-1

CONTINUE

Install four 100 μ H chokes (#45-604, brn-blk-brn) at the following locations. Install these chokes the same way as resistors.

- () L802.
- () L807.
- () L806.
- () L803.

- () Solder the leads to the foil and cut off the excess lead lengths.

The remaining diodes and choke will be installed later.

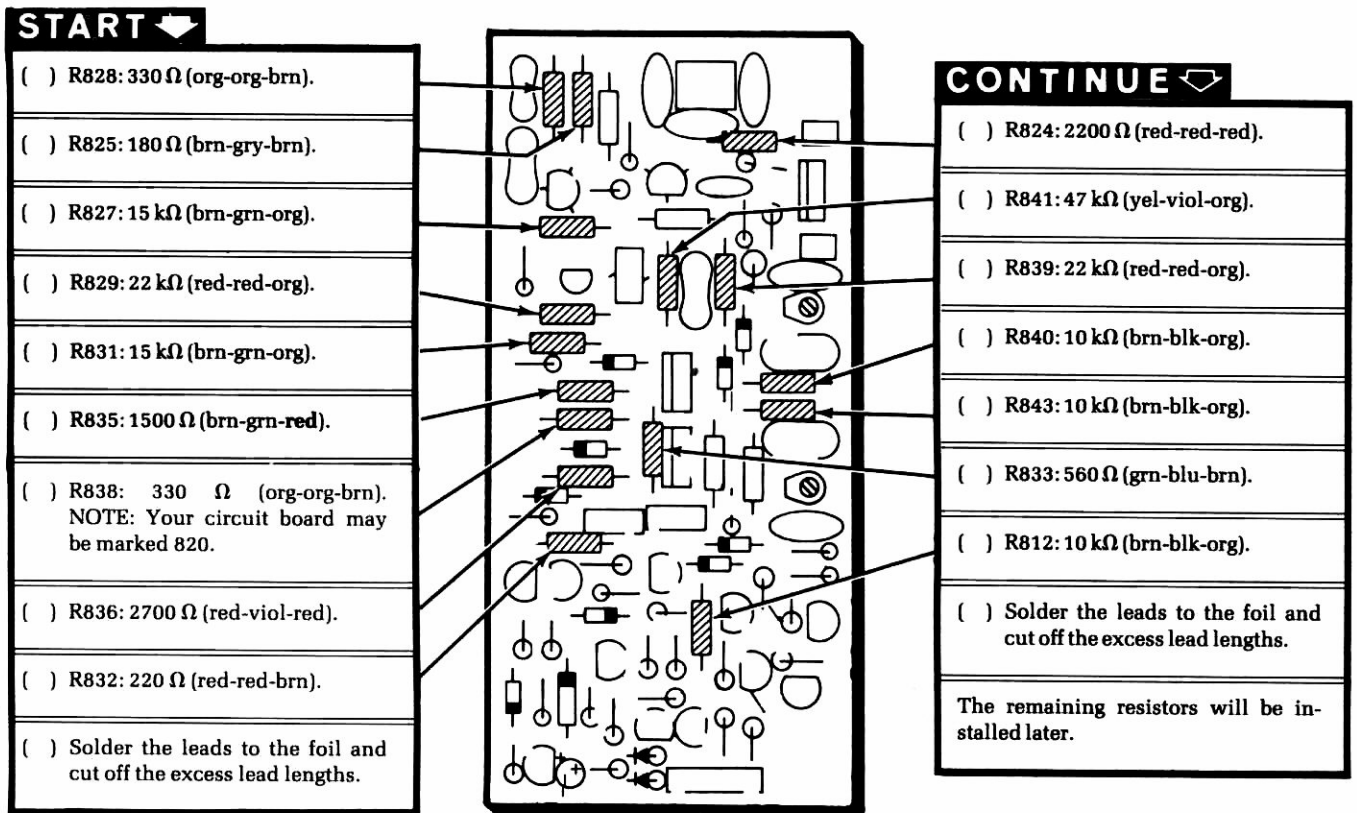

PICTORIAL 9-2

START ↘

When you install a ceramic trimmer, align its flat with the flat outline on the circuit board and insert the pins of the trimmer into their board holes. Press the shoulders of the pins against the board and solder the pin to the foil when the trimmer is installed.



() C816: 3.2-18 pF ceramic trimmer.

() C822: 3.2-18 pF ceramic trimmer.

NOTE: When you install a vertically mounted diode, position the banded end UP and the body of the diode over the larger circle on the board.

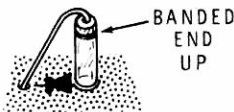

() D806: 1N4149 diode (#56-56).

() D807: 1N4149 diode (#56-56).

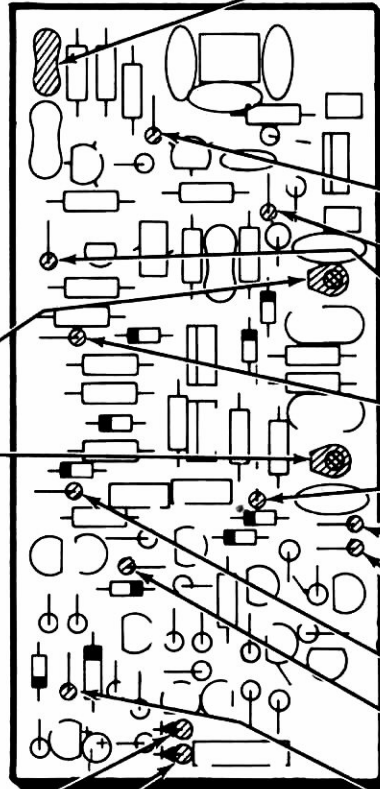

PICTORIAL 9-3

CONTINUE ↙

() C811: 120 pF mica.

NOTE: Mount the following glass ceramic capacitors vertically. These capacitors may be installed either way in the circuit board. Be careful when you form the leads on these capacitors so you do not break them.

() C808: .01 μF (103) glass ceramic.

() C804: .01 μF (103) glass ceramic.

() C813: .01 μF (103) glass ceramic.

() C814: .01 μF (103) glass ceramic.

() C823: .01 μF (103) glass ceramic.

() C818: .01 μF (103) glass ceramic.

() C801: .01 μF (103) glass ceramic.

() C815: .01 μF (103) glass ceramic.

() C824: .01 μF (103) glass ceramic.

() C802: .01 μF (103) glass ceramic.

() Solder the leads to the foil and cut off the excess lead lengths.

START

NOTE: Mount the following resistors vertically where this is indicated by the outlines on the circuit board.

- R826: 1000 Ω (brn-blk-red).
- R815: 56 Ω (grn-blu-blk).
- R808: 10 k Ω (brn-blk-org).
- R807: 10 k Ω (brn-blk-org).
- R813: 3300 Ω (org-org-red).
- R814: 10 k Ω (brn-blk-org).
- R821: 10 k Ω (brn-blk-org).
- R818: 3300 Ω (org-org-red).
- R816: 10 k Ω (brn-blk-org).
- R817: 22 k Ω (red-red-org).
- R819: 10 k Ω (brn-blk-org).
- Solder the leads to the foil and cut off the excess lead lengths.

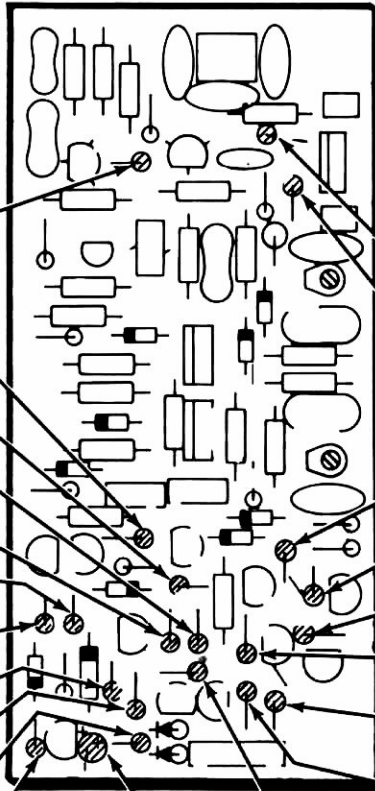

CONTINUE

- R822: 100 Ω (brn-blk-brn).
- R842: 2200 Ω (red-red-red).
- R803: 10 k Ω (brn-blk-org).
- R806: 10 k Ω (brn-blk-org).
- R805: 3300 Ω (org-org-red).
- R802: 3300 Ω (org-org-red).
- R804: 10 k Ω (brn-blk-org).
- R801: 10 k Ω (brn-blk-org).
- R811: 10 k Ω (brn-blk-org).

NOTE: When you install electrolytics, be sure to match the plus (+) mark on the capacitor with the plus (+) mark on the circuit board, or match the minus (-) mark on the capacitor with minus mark on the circuit board.

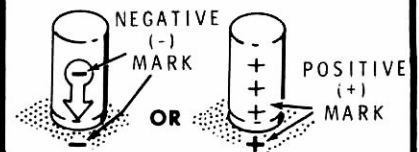

- C803: 10 μ F electrolytic.
- Solder the leads to the foil and cut off the excess lead lengths.

PICTORIAL 9-4

START →

NOTE: When you install a transistor in each of the following steps, align its flat with the flat on the board. Insert the leads into their correct holes. Position the transistor 1/4" above the board. Then solder the leads to the foil and cut off the excess lead lengths.

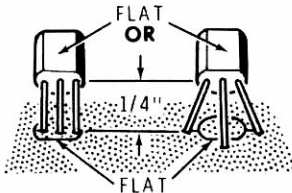

() Q813: MPS6520 transistor (#417-134).

() Q814: MPS6521 transistor (#417-172).

() Q804: X29A829 transistor (#417-201).

() Q802: X29A829 transistor (#417-201).

() Q805: X29A829 transistor (#417-201).

() Q808: X29A829 transistor (#417-201).

() Q812: X29A829 transistor (#417-201).

() Q809: X29A829 transistor (#417-201).

() Q811: MPSA20 transistor (#417-801).

() Q806: MPSA20 transistor (#417-801).

() Q807: MPSA20 transistor (#417-801).

() Q801: MPSA20 transistor (#417-801).

() Q803: MPSA20 transistor (#417-801).

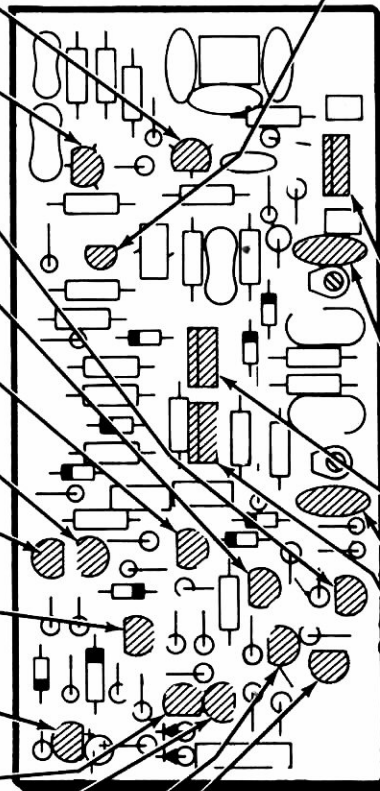

PICTORIAL 9-5

CONTINUE →

() D809: MU2110 diode (#56-640). Align the flat on the diode with the flat on the board. Insert the leads into their correct holes. Position the diode 1/4" above the board. Then solder the leads to the foil and cut off the excess lead lengths.

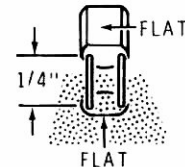

When you install a control, bend its pins straight down, align the body of the control with the wide space on the board and push the pins in their holes with the control tight against the board. Solder the pins to the foil and cut off the excess lead lengths.

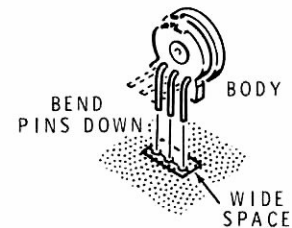

() R823: 100Ω control.

() C817: 7.7 pF ceramic.

() R834: 1000Ω (1k) control.

() C821: 7.7 pF ceramic.

() R837: 1000Ω (1k) control.

() Solder the leads to the foil and cut off the excess lead lengths.

START

NOTE: Solder the pins or leads of each part as it is installed in this Pictorial. Then cut off any excess pin or lead lengths.

- () L801: .44 μ H coil (#40-2075). Insert the pins of the coil into their holes and push the coil tight against the board. The coil will only fit one way.

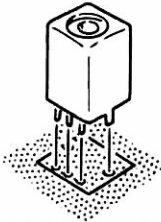

- () C812: 220 pF mica.

- () L804: 22 μ H toroid coil (#40-2064). Position the coil against the board.



- () C819: 160 pF mica.

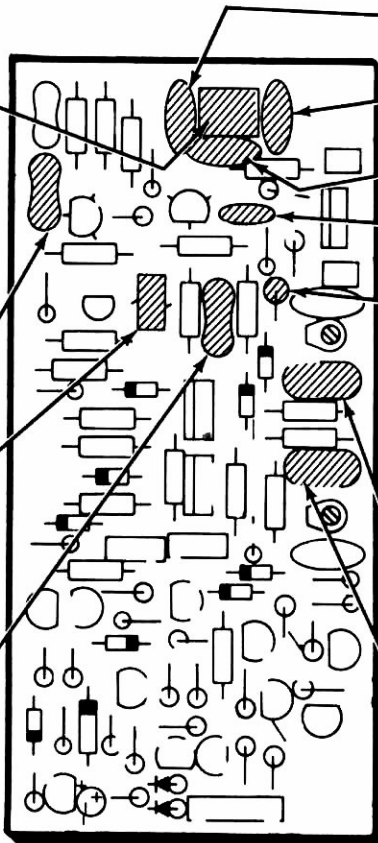

CONTINUE

- () C807: 680 pF ceramic.

- () C805: 220 pF ceramic.

- () C806: 270 pF ceramic.

- () C809: .05 μ F ceramic.

- () L805: 100 μ H choke (#45-604, brn-blk-brn).

When you install a crystal, push it tight against the board. Then solder the three leads to the foil.

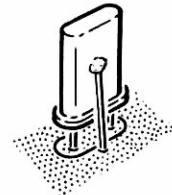

- () Y801: 8.8286 MHz crystal (#404-638).

- () Y802: 8.8314 MHz crystal (#404-639).

PICTORIAL 9-6

START ↘

- () Locate two 3-pin plugs and cut off and discard one pin from each plug.

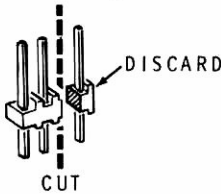

When you install a plug, push its **short** pins all-the-way into the board holes. Then solder the pins to the foil.

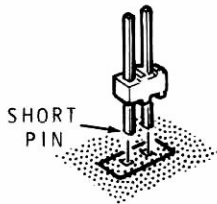

- () P801: 2-pin plug.
- () P802: 2-pin plug.
- () P803: 3-pin plug.
- () P804: 3-pin plug.
- () P805: 5-pin plug.

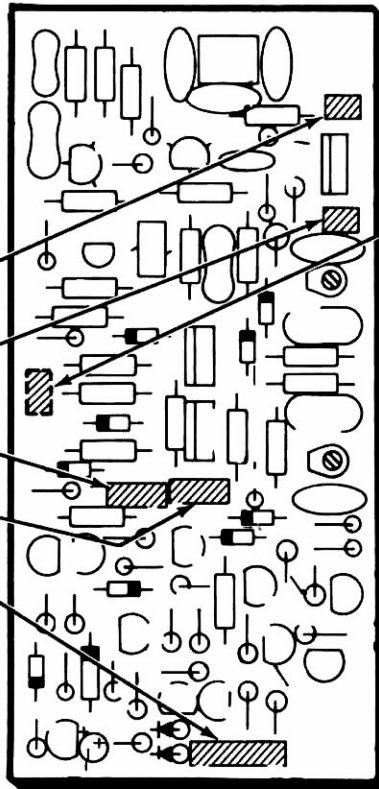

PICTORIAL 9-7

CONTINUE ↘

- () Turn the circuit board over and solder the spring contact to the foil at the indicated location. Hold the spring clip with pliers so you do not burn your fingers.

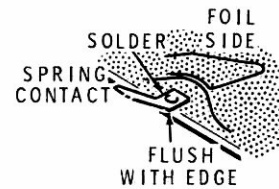

CIRCUIT BOARD CHECKOUT

Carefully inspect the circuit board for the following conditions.

- () Unsoldered connections.
- () Poor solder connections.
- () Solder bridges between foil patterns.
- () Protruding leads which could touch together.
- () Transistors for the proper type and installation.
- () Electrolytic capacitor for the correct position of the positive (+) lead.
- () Diodes for proper type and position of the banded end.

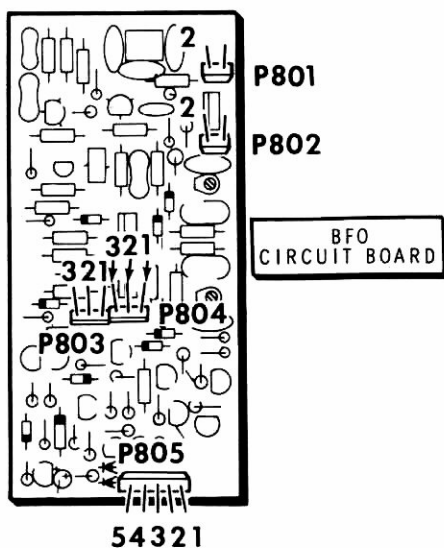

PICTORIAL 9-8

INITIAL TESTS

NOTE: In the following steps, the setting of your ohmmeter is indicated in parentheses, "(R × 10k)" for example, because meaningful readings cannot be taken using a single range. Be sure to zero your ohmmeter each time you change its range.

Refer to Pictorial 9-8 for the following steps.

- () Set the controls on the circuit board to the centers of their rotation.
- () Connect the common ohmmeter lead to the spring contact on the foil side of the circuit board.

Use the positive ohmmeter probe to check the BFO circuit board plugs for the following readings. Note that, as on previous circuit boards, the steps are abbreviated.

NOTE: Do not change ohmmeter ranges unless a step directs you to do so.

- () P801-2. 2000 Ω to 3000 Ω . Check C805 through C808. (R × 1000).
- () P802-2. Approximately 50 Ω . Check C805 through C808. (R × 10).
- () P803-1. 50 k Ω to 100 k Ω . Check C802, D804, Q808. (R × 10k).
- () P803-2. 50 k Ω to 100 k Ω . Check C815, D812.
- () P803-3. Approximately 3000 Ω . Check Q808. (R × 1000).
- () P804-1. Approximately 7000 Ω . Check Q805, Q809.
- () P804-2. Approximately 100 k Ω . Check Q805. (R × 10k).
- () P804-3. Approximately 70 k Ω . Check C824, Q806, Q809.
- () P805-1. Approximately 80 k Ω . Check Q803.
- () P805-2. Approximately 80 k Ω . Check Q801.
- () P805-3. 200 k Ω to 300 k Ω . Check Q811, D806, D807, C803.
- () P805-4 & 5. 200 k Ω to 300 k Ω . Check Q811, D806, D807, C803.

This completes the "Initial Tests" of your BFO circuit board. Set the circuit board aside until it is called for during the assembly of the chassis. Proceed to "Controller Circuit Board."

CONTROLLER CIRCUIT BOARD

PARTS LIST

() Refer to the Pack Index Sheet and locate Pack #10. Then remove the parts from this pack and check each part against the following list. The key numbers correspond to the numbers on the "Controller Circuit Board Parts Pictorial" (Illustration Booklet, Page 9). Return any part that is packed in an individual envelope, with the part number on it, back into its envelope until that part is called for in a step. Do not throw

away any packing material until you account for all the parts.

To order a replacement part, always include the PART NUMBER. Use the Parts Order Form furnished with this kit. If a Parts Order Form is not available, refer to "Replacment Parts" inside the rear cover of this Manual. For prices, refer to the separate "Heath Parts Price List."

KEY No.	HEATH Part No.	QTY.	DESCRIPTION	CIRCUIT Comp. No.
---------	----------------	------	-------------	-------------------

RESISTORS

NOTES:

- Resistors may be packed in more than one envelope. Open all of the resistor envelopes in this pack before you check the resistors against the following Parts List.
- The following resistors are rated at 1/4-watt and have a tolerance of 5% (fourth band gold) unless otherwise noted.

A1	6-101-12	3	100 Ω (brn-blk-brn)	R714, R755, R764
A1	6-151-12	4	150 Ω (brn-grn-brn)	R706, R718, R724, R771
A1	6-271-12	3	270 Ω (red-viol-brn)	R705, R744, R768
A1	6-331-12	2	330 Ω (org-org-brn)	R704, R767
A1	6-471-12	1	470 Ω (yel-viol-brn)	R756
A1	6-561-12	2	560 Ω (grn-blu-brn)	R762, R763
A1	6-102-12	4	1000 Ω (brn-blk-red)	R731, R736, R742, R748

KEY No.	HEATH Part No.	QTY.	DESCRIPTION	CIRCUIT Comp. No.
---------	----------------	------	-------------	-------------------

Resistors (Cont'd.)

A1	6-222-12	6	2200 Ω (red-red-red)	R716, R722, R727, R733, R738, R749
A1	6-392-12	2	3900 Ω (org-wht-red)	R753, R754
A1	6-472-12	10	4700 Ω (yel-viol-red)	R707, R708, R715, R719, R725, R729, R735, R741, R758, R769
A1	6-562-12	4	5600 Ω (grn-blu-red)	R702, R751, R752, R765
A1	6-682-12	2	6800 Ω (blu-gry-red)	R703, R766
A1	6-822-12	2	8200 Ω (gry-red-red)	R709, R711
A1	6-103-12	13	10 kΩ (brn-blk-org)	R701, R712, R713, R717, R723, R732, R737, R743, R745, R746, R747, R759, R761
A1	6-223-12	4	22 kΩ (red-red-org)	R728, R734, R739, R757
A1	6-473-12	2	47 kΩ (yel-viol-org)	R721, R726

Heathkit®

KEY No.	HEATH Part No.	QTY.	DESCRIPTION	CIRCUIT Comp. No.
---------	----------------	------	-------------	-------------------

CAPACITORS

Mica

B1	20-139	4	330 pF	C703, C704, C743, C744
----	--------	---	--------	------------------------

Ceramic

B2	21-742	1	22 pF	C741
B2	21-7	3	33 pF	C727, C728, C729
B2	21-140	5	.001 μF (1000 pF)	C706, C707, C717, C719, C745
B2	21-176	1	.01 μF	C746
B2	21-143	13	.05 μF	C701, C705, C715, C721, C726, C735, C742, C748, C749, C751, C752, C753, C754

Electrolytic

B3	25-922	3	.68 μF	C734, C738, C747
B3	25-925	1	4.7 μF	C733
B3	25-880	1	10 μF	C737
B3	25-927	2	22 μF	C731, C732
B3	25-905	1	470 μF	C736

Mylar

B5	27-68	1	.0033 μF (3300 pF)	C714
B5	27-147	2	.0056 μF (5600 pF)	C709, C712
B5	27-129	2	.047 μF	C723, C725
B5	27-161	1	.01 μF	C713
B6	27-221	2	.22 μF (22 or 224)	C708, C711
B6	27-220	4	.47 μF (47 or 474)	C716, C718, C722, C724

Trimmers

B7	31-71	1	3.2-18 pF (blue screw)	C702
B7	31-85	1	5-25 pF (violet screw)	C739

KEY No.	HEATH Part No.	QTY.	DESCRIPTION	CIRCUIT Comp. No.
---------	----------------	------	-------------	-------------------

DIODES

C1	57-65	1	1N4002	D709
C1	56-56	5	1N4149	D702, D704, D706, D708, D711
C2	56-648	1	MV109	D701

TRANSISTORS — INTEGRATED CIRCUITS (ICs)

NOTES:

- Transistors and integrated circuits may be marked for identification in any of the following four ways:
 - Part number.
 - Type number. (On integrated circuits, this refers only to the numbers; the letters may be different or missing.)
 - Part number and type number.
 - Part number with a type number other than the one listed.
- Some of the ICs may be packed in conductive foam. Do not remove these ICs from the foam until a step directs you to install them.

D1	417-154	1	2N2369 transistor	Q719
D2	417-801	14	MPSA20 transistor	Q703, Q704, Q705, Q706, Q707, Q708, Q709, Q711, Q712, Q713, Q714, Q715, Q716, Q717
D2	417-172	3	MPS6521 transistor	Q701, Q702, Q718
D3	442-39	3	LM301AN IC	U704, U707, U713
D3	443-703	1	MC14001CP IC	U702
D3	443-712	1	MC14025AL IC	U711
D3	443-713	1	MC14028 IC	U709
D3	443-730	1	74LS74 IC	U701
D3	443-799	1	74LS157 IC	U706
D3	443-887	1	4023 IC	U708
D3	443-1030	3	MC145145 IC	U703, U705, U712
D3	444-94	1	MK3875 IC	U710

KEY No.	HEATH Part No.	QTY.	DESCRIPTION	CIRCUIT Comp. No.
---------	----------------	------	-------------	-------------------

CONNECTORS — SOCKETS

E1	432-121	7	Circuit board pin (includes one extra)	
E2	432-134	3	Wire socket (includes 1 extra)	
E3	432-865	2	3-pin socket shell	
E4	432-866	19	Small spring connector (includes one extra)	
E5	432-969	4	5-pin plug	
E6	432-970	1	5-pin socket shell	
E7	432-1030	4	2-pin socket shell	
E8	432-1265	1	3-pin plug	
E9	434-230	3	8-pin IC socket	
E9	434-253	1	40-pin IC socket	
E9	434-298	4	14-pin IC socket	

KEY No.	HEATH Part No.	QTY.	DESCRIPTION	CIRCUIT Comp. No.
---------	----------------	------	-------------	-------------------

Connectors — Sockets (Cont'd)

E9	434-299	2	16-pin IC socket	
E9	434-310	3	18-pin IC socket	

MISCELLANEOUS

F1	45-604	2	100 μ H choke (brn-blk-brn)	L701, L702
	85-2655-3	1	Controller circuit board	
F2	404-645	1	10 MHz crystal (10,000 kHz)	Y702
F3	404-637	1	8.04 MHz crystal	Y701
F4	412-632	3	NLS5076A LED	D703, D705, D707

STEP-BY-STEP ASSEMBLY

START

() Position the controller circuit board printed side up as shown. **IMPORTANT:** This circuit board has foil on both sides. **DO NOT** solder to the foil on the printed (component) side of the board.

NOTE: Only a portion of the circuit board is shown in some Pictorials. The small "Identification Drawing" at the top of the page shows the area of the board to be assembled.

NOTE: When you install a diode, always align its banded end with the band on the board. See Detail 10-1A.

() D706: 1N4149 diode (#56-56).

() D708: 1N4149 diode (#56-56).

() D704: 1N4149 diode (#56-56).

() L702: 100 μ H choke (#45-604, brn-blk-brn).

NOTE: The leads of the following diode are quite short. Since the circuit board holes are plated through, however, the solder should wick into the hole for a good solder connection.

() D701: MV109 diode (#56-648). Solder the leads to the foil when you install it. Check the leads to make sure they are well soldered.

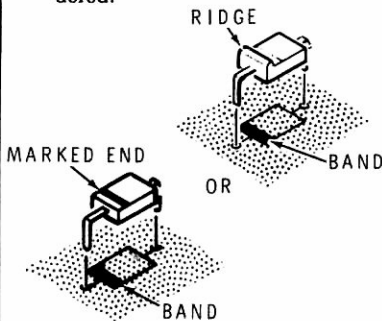

() L701: 100 μ H choke (#45-604, brn-blk-brn).

() D702: 1N4149 diode (#56-56).

() D709: 1N4002 diode (#57-65).

() D711: 1N4149 diode (#56-56).

() Solder the leads to the foil and cut of the excess lead lengths.

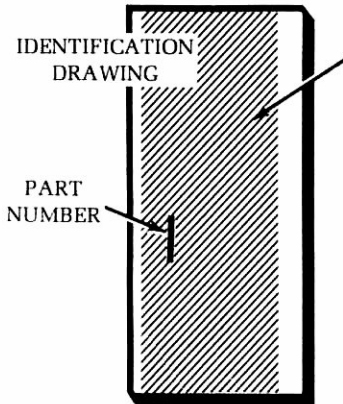

The steps performed in this Pictorial are in this area of the circuit board.

NOTE: DIODES MAY BE SUPPLIED IN ANY OF THE FOLLOWING SHAPES.

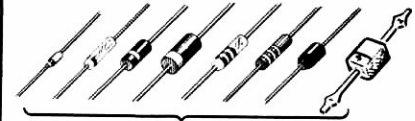

Detail 10-1A

CONTINUE

NOTE: When you install an IC socket, be sure the index mark is still visible after the socket is installed. Then solder the pins to the foil.

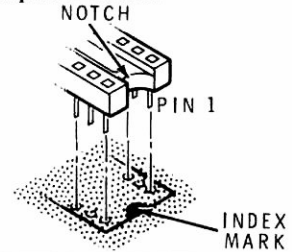

() 18-pin IC sockets at U712 and U705.

() Position an 18-pin socket as shown below (note the location of the notch). Then grasp pin 16 of the socket with long-nose pliers and pull the pin all the way out of the socket. The pin will not be used.

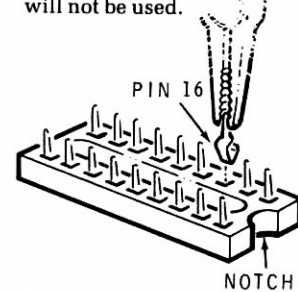

() Install the modified socket at U703. Be sure to match the notch on this socket with the index mark on the circuit board.

() 16-pin IC sockets at U706 and U709.

() 14-pin IC sockets at U711, U702, U708, and U701.

() 8-pin IC sockets at U713, U707, and U704.

() 40 pin IC socket at U710.

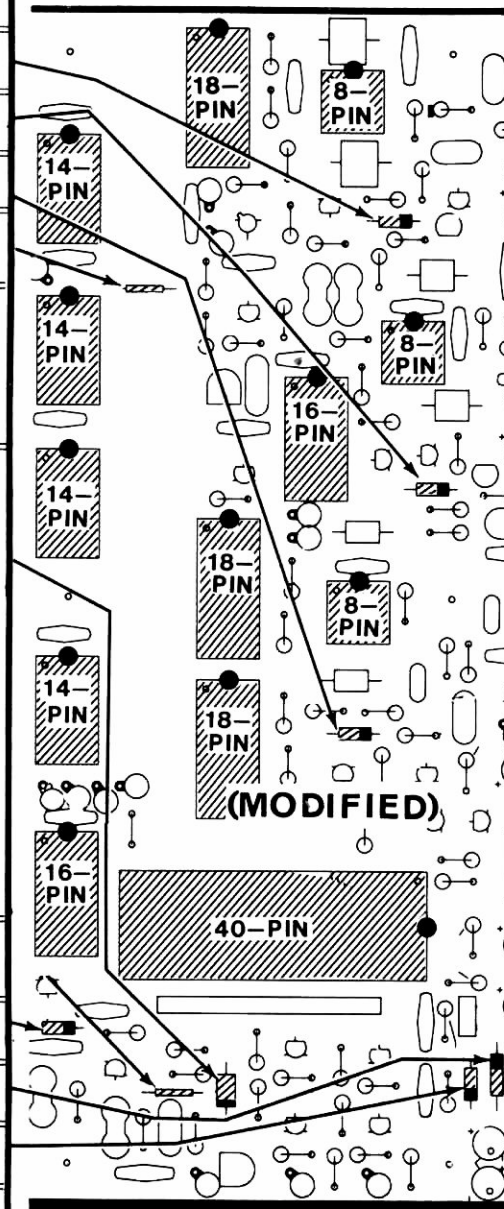

PICTORIAL 10-1

IDENTIFICATION
DRAWING

PART
NUMBER

The steps performed in this Pictorial are
in this area of the circuit board.

START ↘

NOTE: All the resistors on this circuit board are mounted vertically. Solder the longer lead first. Then straighten the resistor, solder the other lead, and cut off the excess lead lengths.

() R751: 5600 Ω (grn-blu-red).

() R752: 5600 Ω (grn-blu-red).

() R737: 10 kΩ (brn-blk-org).

() R771: 150 Ω (brn-grn-brn).

() R769: 4700 Ω (yel-viol-red).

() R767: 330 Ω (org-org-brn).

() R765: 5600 Ω (grn-blu-red).

() Solder the leads to the foil and
cut off the excess lead lengths.

() R757: 22 kΩ (red-red-org).

() R702: 5600 Ω (grn-blu-red).

() R704: 330 Ω (org-org-brn).

() R706: 150 Ω (brn-grn-brn).

() R701: 10 kΩ (brn-blk-org).

() R703: 6800 Ω (blu-gry-red).

() R705: 270 Ω (red-viol-brn).

() Solder the leads to the foil and
cut off the excess lead lengths.

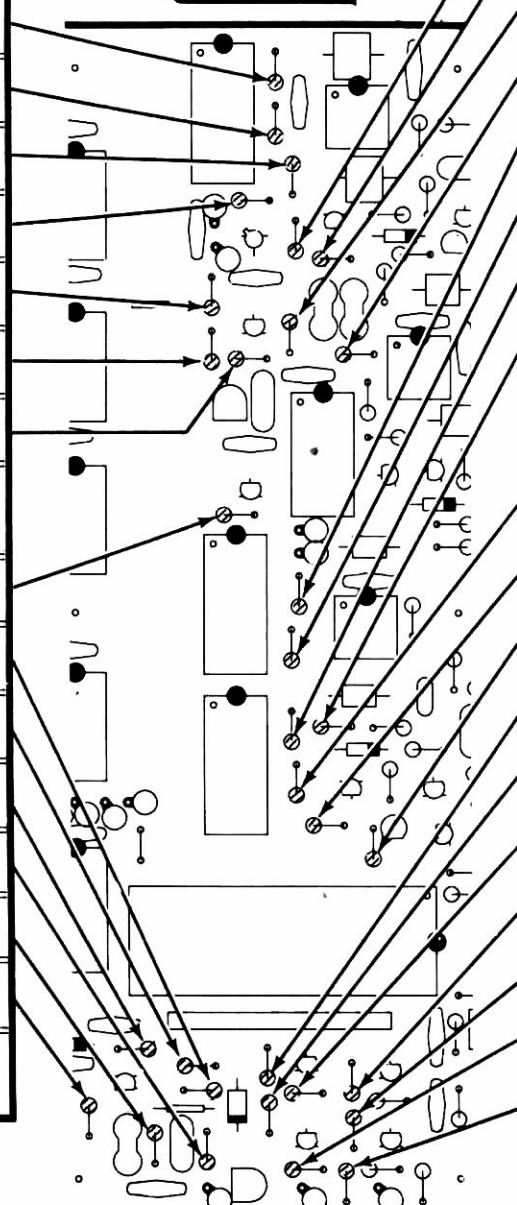

CONTINUE ↙

() R768: 270 Ω (red-viol-brn).

() R736: 1000 Ω (brn-blk-red).

() R766: 6800 Ω (blu-gry-red).

() R759: 10 kΩ (brn-blk-org).

() R756: 470 Ω (yel-viol-brn).

() R743: 10 kΩ (brn-blk-org).

() R707: 4700 Ω (yel-viol-red).

() R731: 1000 Ω (brn-blk-red).

() Solder the leads to the foil and
cut off the excess lead lengths.

() R708: 4700 Ω (yel-viol-red).

() R732: 10 kΩ (brn-blk-org).

() R727: 2200 Ω (red-red-red).

() R719: 4700 Ω (yel-viol-red).

() R717: 10 kΩ (brn-blk-org).

() R721: 47 kΩ (yel-viol-org).

() R725: 4700 Ω (yel-viol-red).

() R723: 10 kΩ (brn-blk-org).

() R716: 2200 Ω (red-red-red).

() R718: 150 Ω (brn-grn-brn).

() Solder the leads to the foil and
cut off the excess lead lengths.

PICTORIAL 10-2

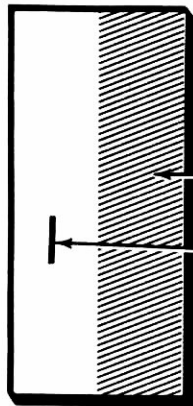

IDENTIFICATION
DRAWING

The steps performed in this Pictorial are
in this area of the circuit board.

PART
NUMBER

START ↘

- () R755: 100 Ω (brn-blk-brn).
- () R734: 22 kΩ (red-red-org).
- () R735: 4700 Ω (yel-viol-red).
- () R733: 2200 Ω (red-red-red).
- () R758: 4700 Ω (yel-viol-red).
- () R761: 10 kΩ (brn-blk-org).
- () R741: 4700 Ω (yel-viol-red).
- () R709: 8200 Ω (gry-red-red).
- () Solder the leads to the foil and cut off the excess lead lengths.
- () R712: 10 kΩ (brn-blk-org).
- () R711: 8200 Ω (gry-red-red).
- () R729: 4700 Ω (yel-viol-red).
- () R728: 22 kΩ (red-red-org).
- () R744: 270 Ω (red-viol-brn).
- () R726: 47 kΩ (yel-viol-org).
- () R722: 2200 Ω (red-red-red).
- () R724: 150 Ω (brn-grn-brn).
- () Solder the leads to the foil and cut off the excess lead lengths.

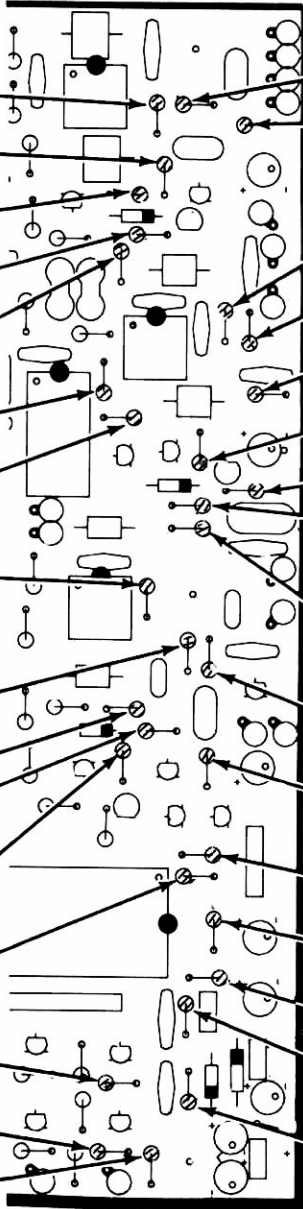

PICTORIAL 10-3

CONTINUE ↘

- () R753: 3900 Ω (org-wht-red).
- () R754: 3900 Ω (org-wht-red).
- () R762: 560 Ω (grn-blu-brn).
- () R764: 100 Ω (brn-blk-brn).
- () R763: 560 Ω (grn-blu-brn).
- () R739: 22 kΩ (red-red-org).
- () R738: 2200 Ω (red-red-red).
- () R742: 1000 Ω (brn-blk-red).
- () Solder the leads to the foil and cut off the excess lead lengths.
- () R714: 100 Ω (brn-blk-brn).
- () R713: 10 kΩ (brn-blk-org).
- () R715: 4700 Ω (yel-viol-red).
- () R746: 10 kΩ (brn-blk-org).
- () R745: 10 kΩ (brn-blk-org).
- () R747: 10 kΩ (brn-blk-org).
- () R748: 1000 Ω (brn-blk-red).
- () R749: 2200 Ω (red-red-red).
- () Solder the leads to the foil and cut off the excess lead lengths.

START 

When you install a circuit board pin or a wire socket, push the proper end into the board hole until the ridge is tight against the board. Then solder it to the foil.

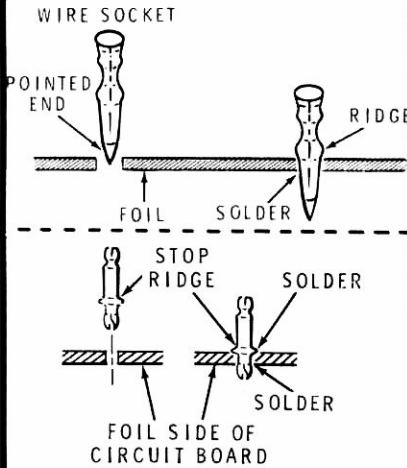

() Circuit board pin at N.

() Circuit board pin at B.

When you install an LED, align its flat outline on the board and insert the leads so the LED is 1/8" above the circuit board. Then solder the leads to the foil and cut off the excess lead lengths.

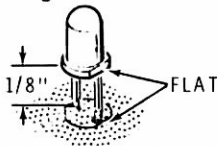

() D705: NLS5076A LED (#412-632).

() D707: NLS5076A LED (#412-632).

() D703: NLS5076A LED (#412-632).

() Two wire sockets at J.

() Circuit board pin at 13.8.

() Circuit board pin at Ø2.

() Circuit board pin at Ø1.

() Circuit board pin at A.

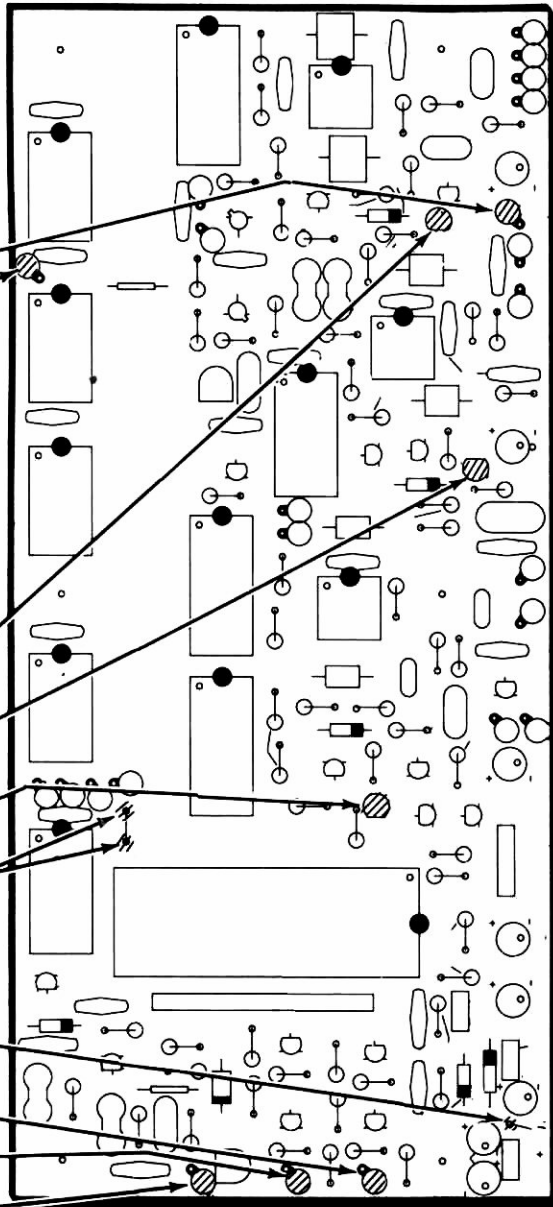

PICTORIAL 10-4

START

When you install a transistor, align its flat or tab with the flat or tab outline on the circuit board and insert the transistor leads in their correct holes. Position the transistor 1/4" above the board and solder the leads to the foil. Then cut off the excess lead lengths. See Detail 10-5A.

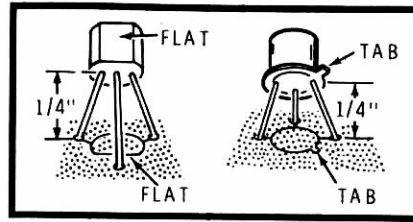

Detail 10-5A

- () Q712: MPSA20 transistor (#417-801).
- () Q713: MPSA20 transistor (#417-801).
- () Q719: 2N2369 transistor (#417-154).
- () Q718: MPS6521 transistor (#417-172).
- () Q714: MPSA20 transistor (#417-801).
- () Q715: MPSA20 transistor (#417-801).
- () Q708: MPSA20 transistor (#417-801).
- () Q707: MPSA20 transistor (#417-801).
- () Q709: MPSA20 transistor (#417-801).
- () Q711: MPSA20 transistor (#417-801).
- () Q717: MPSA20 transistor (#417-801).
- () Q716: MPSA20 transistor (#417-801).
- () Q702: MPS6521 transistor (#417-172).
- () Q701: MPS6521 transistor (#417-172).
- () Q704: MPSA20 transistor (#417-801).
- () Q706: MPSA20 transistor (#417-801).
- () Q703: MPSA20 transistor (#417-801).
- () Q705: MPSA20 transistor (#417-801).

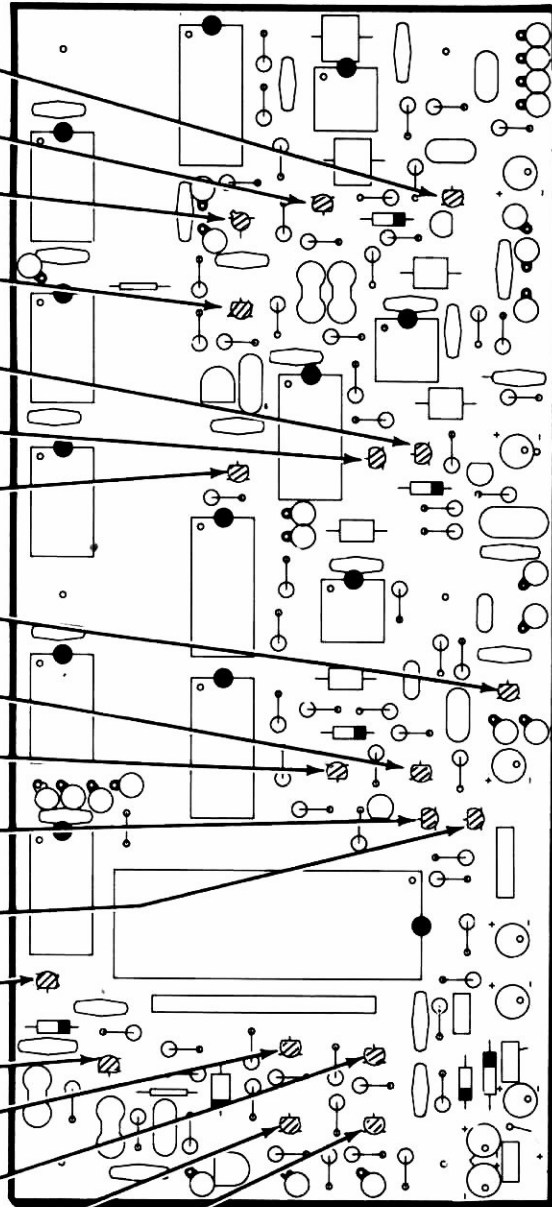

PICTORIAL 10-5

IDENTIFICATION
DRAWING

PART
NUMBER

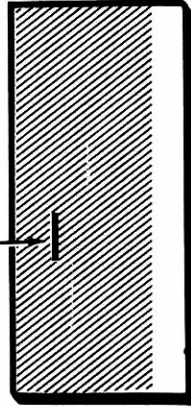

CONTINUE ↘

START ↘

- () ✓ C748: .05 μ F ceramic.
- () C749: .05 μ F ceramic.
- () C742: .05 μ F ceramic.
- () C751: .05 μ F ceramic.
- () C752: .05 μ F ceramic.
- () Solder the leads to the foil and cut off the excess lead lengths.
- () C753: .05 μ F ceramic.
- () C706: .001 μ F ceramic.
- () C705: .05 μ F ceramic.
- () C704: 330 pF mica.
- () C703: 330 pF mica.
- () C701: .05 μ F ceramic.
- () Solder the leads to the foil and cut off the excess lead lengths.

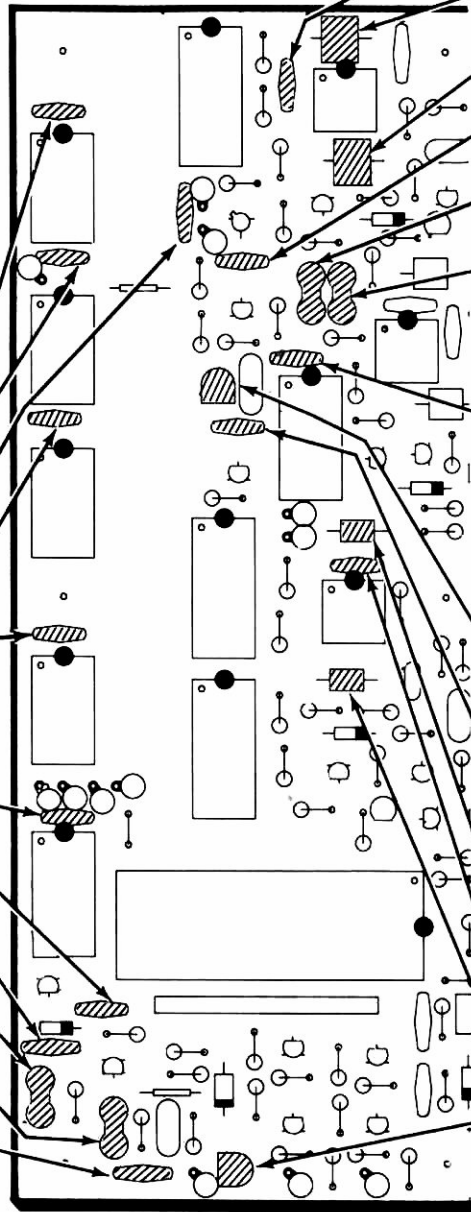

- () C729: 33 pF ceramic.
- () C722: .47 μ F (μ 47 or 474) Mylar.
- () C724: .47 μ F (μ 47 or 474) Mylar.
- () C745: .001 μ F ceramic.
- () C743: 330 pF mica.
- () C744: 330 pF mica.
- () Solder the leads to the foil and cut off the excess lead lengths.
- () C754: .05 μ F ceramic.
- NOTE:** When you install a trimmer capacitor, align its flat end with the flat on the board. Push the trimmer tight against the board and solder its leads to the foil.
- () C739: 5-25 pF trimmer (violet screw).
- () C741: 22 pF ceramic. Mount this capacitor 1/8" above the circuit board so you can gain access to the leads later.
- () C708: .22 μ F (μ 22 or 224) Mylar.
- () C727: 33pF ceramic.
- () C711: .22 μ F (μ 22 or 224) Mylar.
- () C702: 3.2-18 pF trimmer (blue screw).
- () Solder the leads to the foil and cut off the excess lead lengths.

PICTORIAL 10-6

The steps performed in this Pictorial are in this area of the circuit board.

PART NUMBER

IDENTIFICATION DRAWING

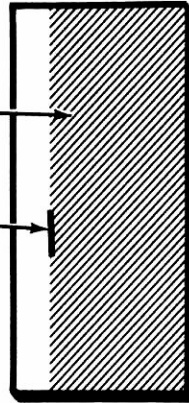

CONTINUE

() C723: .047 μ F Mylar.

NOTE: When you install electrolytic capacitors, always match the positive (+) mark on the capacitor with the positive (+) mark on the circuit board OR match the negative (-) mark on the capacitor with the negative (-) mark on the circuit board.

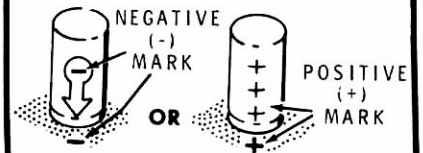

() C732: 22 μ F electrolytic.

() C721: .05 μ F ceramic.

() C719: .001 μ F ceramic.

() C733: 4.7 μ F electrolytic.

() C714: .0033 μ F Mylar.

() Solder the leads to the foil and cut off the excess lead lengths.

() C715: .05 μ F ceramic.

() C707: .001 μ F ceramic.

() C731: 22 μ F electrolytic.

() C737: 10 μ F electrolytic.

() C734: .68 μ F electrolytic.

() C738: .68 μ F electrolytic.

() C747: .68 μ F electrolytic.

() Solder the leads to the foil and cut off the excess lead lengths.

START

() C726: .05 μ F ceramic.

() C725: .047 μ F Mylar.

() C716: .47 μ F (μ F or 474) Mylar.

() C728: 33 pF ceramic.

() C717: .001 μ F ceramic.

() C718: .47 μ F (μ 47 or 474) Mylar.

() Solder the leads to the foil and cut off the excess lead lengths.

() C709: .0056 μ F Mylar.

() C712: .0056 μ F Mylar.

() C713: .01 μ F Mylar.

() C746: .01 μ F ceramic.

() C735: .05 μ F ceramic.

() Solder the leads to the foil and cut off the excess lead lengths.

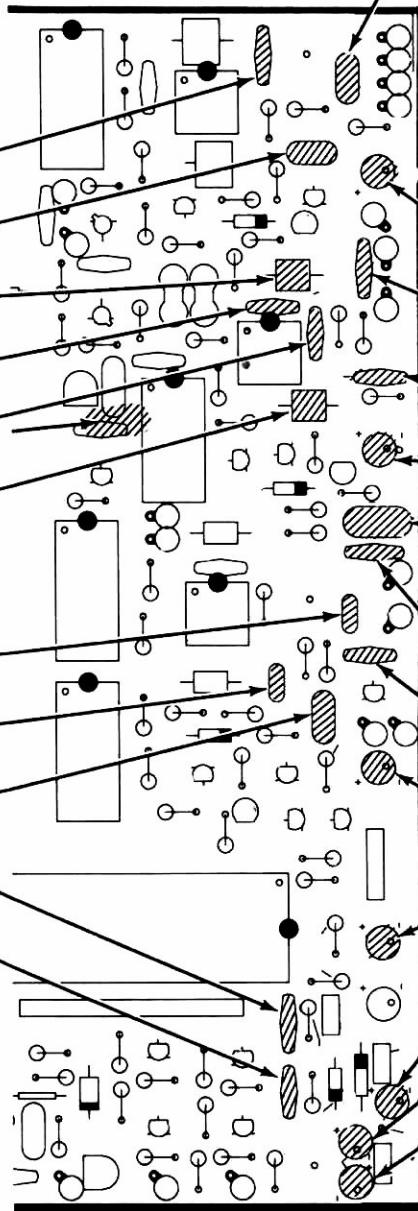

PICTORIAL 10-7

START →

Solder the leads or pins to the foil as you install each part in this Pictorial. Then cut off any excess lead lengths.

() Y702: 10 MHz crystal (#404-645). Solder a 1" small bare wire to the side of the crystal body and to the foil at the center hole on the crystal outline on the circuit board. Use only enough heat to insure a good solder connection.



When you install a plug, insert its shorter pins all the way into the board holes before you solder them to the foil.

() P701: 5-pin plug.

() P703: 3-pin plug.

() P702: Three 5-pin plugs.

() C736: 470 μ F electrolytic. Be sure to observe the correct polarity.

() Y701: 8.04 MHz crystal (#404-637).

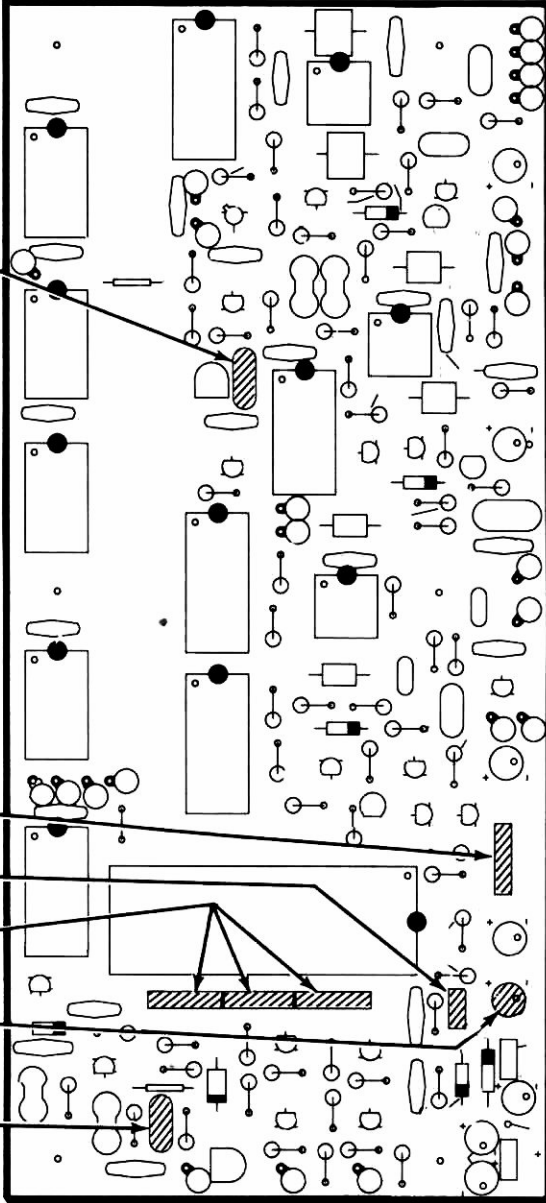

PICTORIAL 10-8

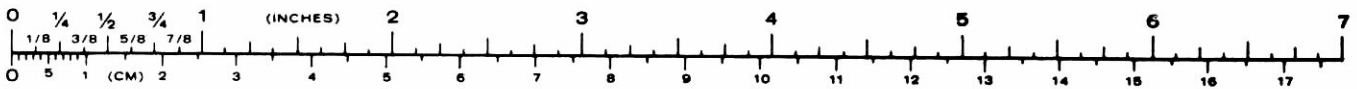

START

CAUTION: Once you have removed the foam pad from a protected IC, DO NOT let go of the IC until it is installed in its socket.

NOTE: When you install an integrated circuit, position the pin 1 end of the integrated circuit at the index mark end of the outline printed on the circuit board. Then insert the integrated circuit pins into their corresponding socket holes and press the integrated circuit down into the socket. Refer to Detail 10-9A to identify the pin 1 end of an integrated circuit.

() U713: LM301ANIC (#442-39).

() U712: MC145145 IC (#443-1030).

() U711: MC14025AL IC (#443-712).

() U702: MC14001CP IC (#443-703).

() U708: 4023 IC (#443-887).

() U707: LM301ANIC (#442-39).

() U706: 74LS157 IC (#443-799).

() U705: MC145145 IC(443-1030).

() U704: LM301ANIC(442-39).

() U701: 74LS74 IC (#443-730).

() U703: MC145145 IC (#443-1030).

() U709: MC14028 IC (#443-713).

() U710: MK3875 IC (#444-94).

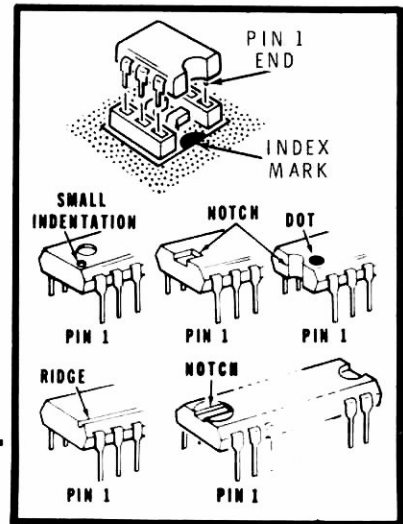

Detail 10-9A

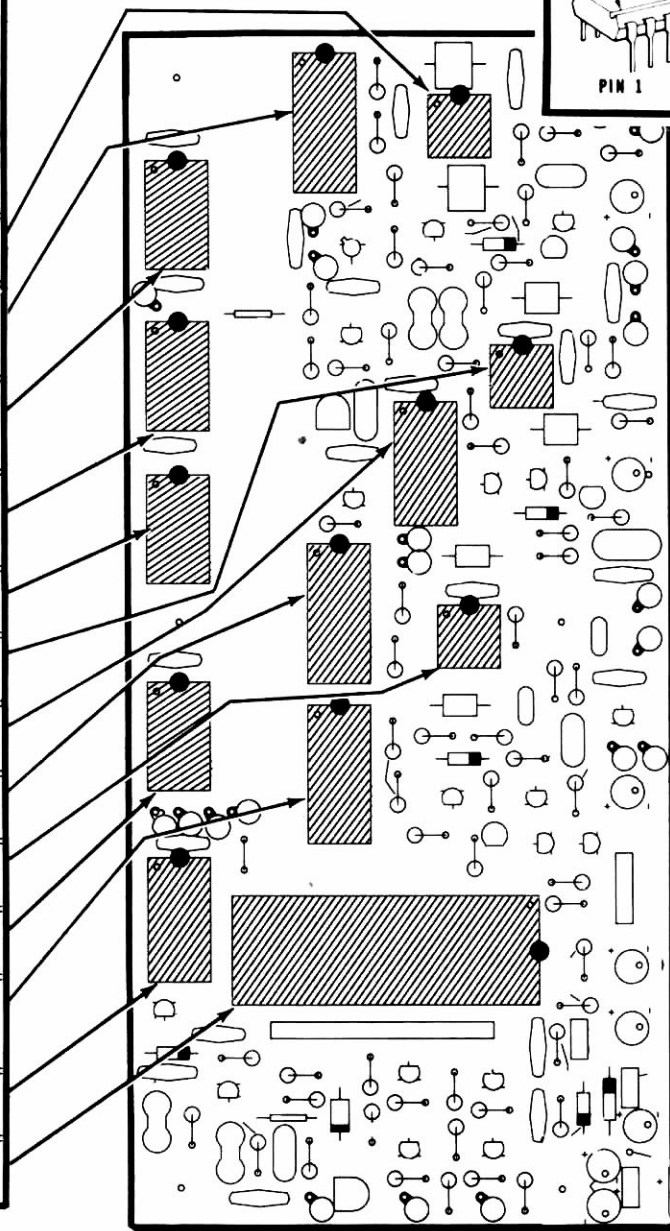

PICTORIAL 10-9

Refer to Pictorial 10-10 (Illustration Booklet, Page 10) for the following steps.

- () Locate the 5-1/2" 3-wire cable (yellow, green, and blue wires) set aside earlier. Then refer to Detail 10-10A Part A (Illustration Booklet, Page 11) and prepare this cable group as follows:

1. Separate the wires at each end of the cable for 3/4".
2. Remove 1/8" of insulation from each wire at one end and 1/4" of insulation from each wire at the other end of the cable.
3. Tightly twist the fine wire strands at each wire end and melt a small amount of solder onto these ends to hold the strands together.

- () Install a small spring connector on the end of each wire at the end of the cable where you removed 1/8" of insulation.

- () Locate a 3-pin socket shell. Then insert the spring connectors on the end of the prepared cable into this socket shell as follows:

Blue wire into hole 1.

Green wire into hole 2.

Yellow wire into hole 3.

- () Set this cable aside temporarily.

- () Locate the 5-1/2" 3-wire cable (violet, gray, and white wires) set aside earlier. Then refer to Part B of Detail 10-10A and prepare this cable group as follows:

1. Separate and prepare the wire ends as you did before.
2. Install small spring connectors on the wires at the end of the cable with 1/8" of insulation removed.

- () Locate a 3-pin socket shell. Then insert the spring connectors on the end of the prepared cable into this socket shell as follows:

White wire into hole 1.

Gray wire into hole 2.

Violet wire into hole 3.

- () Locate a 5-pin socket shell and label it "P805". Then refer to Part C of Detail 10-10A and use the 8" 4-wire cable (black, brown, red, and orange wires) to prepare this cable as shown. Use the same procedure as you did for the 3-wire cables.

Connect the free end of the 4-wire cable to the controller circuit board as follows. Solder each wire to the foil as you connect it and cut off any excess wire ends.

- () Black wire to hole D.

- () Brown wire to hole E.

- () Red wire to hole C.

- () Orange wire to hole F.

Connect and solder the free end of the blue-green-yellow cable to the controller circuit board at U14 as follows:

- () Blue wire to hole I.

- () Green wire to hole G.

- () Yellow wire to hole O.

Connect and solder the free end of the white-gray-violet cable to the controller circuit board at U15 as follows:

- () White wire to hole I.

- () Gray wire to hole G.

- () Violet wire to hole O.

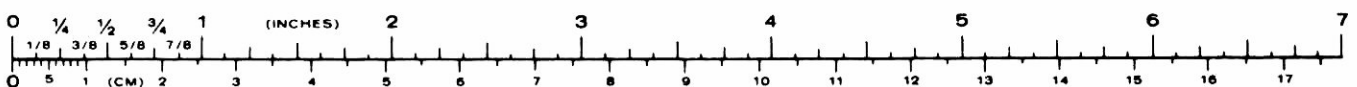

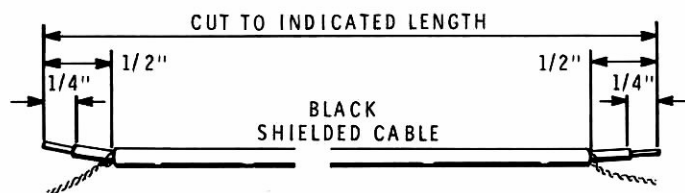
**Detail 10-11A**

Refer to Pictorial 10-11 (Illustration Booklet, Page 12) for the following steps.

- () Refer to Detail 10-11A and prepare the following lengths of black shielded cable:

5"	9-1/2"
4-1/2"	7"
7-1/2"	7"
4"	

- () Cut 1/8" from the leads at one end of the 4-1/2" shielded cable. Then install small spring connectors on this end of the cable.
- () Locate a 2-pin socket shell and label it "P102". Then insert the spring connectors on the prepared shielded cable into this socket shell as follows:
- Inner lead into hole 1.
- Shield wires into hole 2.
- () Cut 1/8" from the leads at one end of the 7-1/2" cable. Then install small spring connectors on this end of the cable.

- () Locate a 2-pin socket shell and label it "P105". Then insert the spring connectors on the prepared shielded cable into this socket shell as follows:

Inner lead into hole 1.

Shield wires into hole 2.

- () Install small spring connectors on one end of the 9-1/2" shielded cable. Use the same procedure as before.

- () Locate a 2-pin socket shell and label it "P107". Then insert the spring connectors on the prepared shielded cable into this socket shell as follows:

Inner lead into hole 1.

Shield wires into hole 2.

- () Install small spring connectors on one end of one of the 7" shielded cables.

- () Locate a 2-pin socket shell and label it "P101". Then insert the spring connectors on the prepared shielded cable into this socket shell as follows:

Inner lead into hole 1.

Shield wires into hole 2.

NOTE: When you solder wires to the foil side (not the printed side) of a circuit board, as in the following steps, keep the insulation 1/8" away from the circuit board to be sure you obtain a good solder connection.

- () Position the controller circuit board foil-side-up as shown in the Pictorial.

Connect one end of the prepared cables to the circuit board as follows. Solder each wire or lead to the foil as you connect it and cut off any excess lead length from the printed side of the circuit board. **NOTE:** The holes are labeled on the printed side of the circuit board.

- () Inner lead at one end of the 5" cable to hole J and the shield wires to hole K.
- () Inner lead of the 4-1/2" cable (with socket P102) to hole G and the shield wires to hole H.
- () Inner lead of the 7-1/2" cable (with socket P105) to hole R and the shield wires to hole S. Use 1/4" of small black sleeving on the shield wires.
- () Inner lead at one end of the 4" cable to hole L and the shield wires to hole M.
- () Inner lead of the 9-1/2" cable (with socket P107) to hole V and the shield wires to hole W. Use 1/4" of small black sleeving on the shield wires.
- () Inner lead at one end of the 7" cable (without a socket) to hole P and the shield wires to hole Q.
- () Inner lead of the 7" cable (with socket P101) to hole T and the shield wires to hole U.
- () Prepare a 5/8" small white-violet solid wire. Only remove 1/8" of insulation from the ends of this wire. Then solder the wire between the indicated foils on the bottom of the circuit board.

CIRCUIT BOARD CHECKOUT

Carefully inspect the circuit board for the following conditions:

- () Unsoldered connections.
- () Poor solder connections.
- () Solder bridges between foil patterns.
- () Protruding leads which could touch together.
- () Diodes for the proper type and correct position of the banded end.
- () Transistors and integrated circuits for the proper type and installation.
- () Electrolytic capacitors for the correct position of the positive (+) lead.

INITIAL TESTS

NOTE: In the following steps, the setting of your ohmmeter is indicated in parentheses, "(R × 10K)" for example, because meaningful readings cannot be taken using a single range. Be sure to zero your ohmmeter each time you change its range.

Refer to Pictorial 10-12 for the following steps.

- () Connect the common ohmmeter lead to a ground point on the controller circuit board foil. **NOTE:** A convenient point is a foil pad at one of the corner circuit board mounting holes.

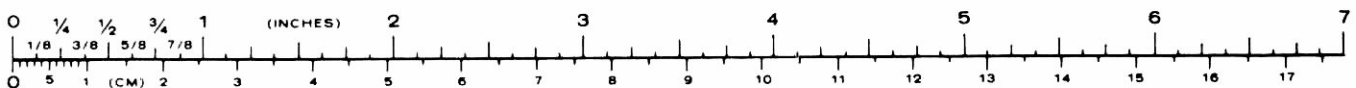

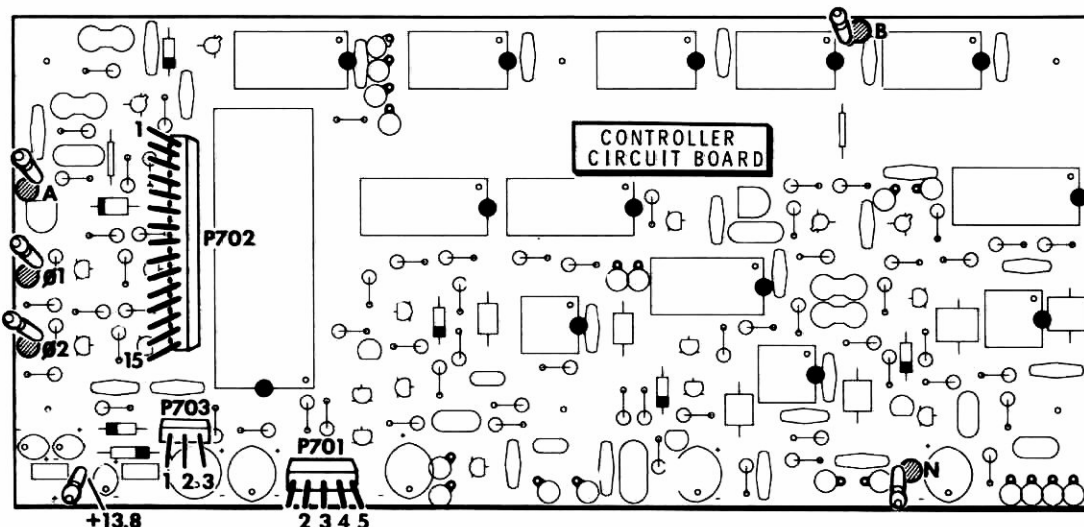

PICTORIAL 10-12

Use the positive ohmmeter probe to check the controller circuit board plugs and pins for the following readings. Note that, as on the previous circuit boards, the steps are abbreviated.

NOTE: Do not change ohmmeter ranges unless a step directs you to do so.

- () Circuit board pin A. Infinity. Check C701, D701. (R × 10K).
- () Circuit board pin B. 50 kΩ to 100 kΩ. Check U702A.
- () Circuit board pin N. 5000 Ω to 10 kΩ. Check U706. (R × 1000).
- () Circuit board pin Ø1. Approximately 2000 Ω. Check Q703.
- () Circuit board pin Ø2. Approximately 2000 Ω. Check Q705.
- () Circuit board pin +13.8. 10 kΩ or greater. Check C737, C738, D709, D711.

- () P703-1&2. 3000 Ω to 4000 Ω. Check U715, C747, the +5V source.

- () P701-2. 8000 Ω to 10 kΩ. Check U710.

- () P701-3. 8000 Ω to 10 kΩ. Check U710.

- () P701-4. 4000 Ω to 10 kΩ. Check Q716, bypass capacitors C748 through C754.

- () P701-5. 8 kΩ to 20 kΩ. Check 12V DC connections (see the Schematic).

- () P702-1 through 15. Make sure none of these pins are shorted to ground. The average readings on these pins should be near 10 kΩ. If the ohmmeter indicates a short circuit, carefully check the circuit board foils for solder bridges in the areas of U702 and U710.

This completes the "Initial Tests" of your controller circuit board. Set the circuit board aside until it is called for during the assembly of the chassis. Proceed to "Synthesizer Circuit Board".

SYNTHESIZER CIRCUIT BOARD

PARTS LIST

- () Refer to the Pack Index Sheet and locate Pack #11. Then remove the parts from this pack and check each part against the following list. The key numbers correspond to the numbers on the "Synthesizer Circuit Board Parts Pictorial" (Illustration Booklet, Page 12). Return any part that is packed in an individual envelope, with the part number on it, back into its envelope until that part is called for in a step. Do not

throw away any packing material until you account for all the parts.

To order a replacement part, always include the PART NUMBER. Use the Parts Order Form furnished with this kit. If a Parts Order Form is not available, refer to "Replacement Parts" inside the rear cover of this Manual. For prices, refer to the separate "Heath Parts Price List."

KEY No.	HEATH Part No.	QTY.	DESCRIPTION	CIRCUIT Comp. No.
---------	----------------	------	-------------	-------------------

RESISTORS

NOTES:

- Resistors may be packed in more than one envelope. Open all of the resistor envelopes in this pack before you check the resistors against the Parts List.
- The following resistors are rated at 1/4-watt and have a tolerance of 5% (fourth band gold) unless otherwise noted.

A1	6-100-12	1	10 Ω (brn-blk-blk)	R125
A1	6-470-12	2	47 Ω (yel-viol-blk)	R113, R135
A1	6-101-12	14	100 Ω (brn-blk-brn)	R103, R108, R109, R118, R119, R126, R127, R131, R137, R138, R145, R147, R149, R156

KEY No.	HEATH Part No.	QTY.	DESCRIPTION	CIRCUIT Comp. No.
---------	----------------	------	-------------	-------------------

Resistors (Cont'd)

A1	6-271-12	6	270 Ω (red-viol-brn)	R107, R136, R141, R144, R154, R161
A1	6-391-12	1	390 Ω (org-wht-brn)	R124
A1	6-471-12	1	470 Ω (yel-viol-brn)	R155
A1	6-561-12	2	560 Ω (grn-blu-brn)	R116, R117
A1	6-821-12	1	820 Ω (gry-red-brn)	R112
A1	6-102-12	8	1000 Ω (brn-blk-red)	R101, R111, R122, R123, R128, R146, R158, R159
A1	6-122-12	1	1200 Ω (brn-red-red)	R114
A1	6-332-12	2	3300 Ω (org-org-red)	R121, R157
A1	6-472-12	4	4700 Ω (yel-viol-red)	R106, R134, R171, R175
A1	6-562-12	1	5600 Ω (grn-blu-red)	R142
A1	6-103-12	5	10 kΩ (brn-blk-org)	R115, R164, R166, R168, R172

KEY No.	HEATH Part No.	QTY.	DESCRIPTION	CIRCUIT Comp. No.	KEY No.	HEATH Part No.	QTY.	DESCRIPTION	CIRCUIT Comp. No.
Resistors (Cont'd)					Capacitors (Cont'd)				
A1	6-223-12	1	22 kΩ (red-red-org)	R162	B2	21-176	12	.01 μF	C107, C111, C113, C114, C123, C127, C133, C138, C142, C144, C146, C165
A1	6-473-12	3	47 kΩ (yel-viol-org)	R169, R173, R174	B2	21-143	7	.05 μF	C151, C152, C156, C157, C162, C163, C182
A1	6-823-12	4	82 kΩ (gry-red-org)	R102, R104, R129, R132	B2	21-95	5	.1 μF	C171, C172, C174, C177, C181
A1	6-104-12	7	100 kΩ (brn-blk-yel)	R105, R133, R139, R143, R152, R153, R167					
A1	6-105-12	2	1 MΩ (brn-blk-grn)	R163, R165					
CAPACITORS					Trimmers				
Mica									
B1	20-130	1	12 pF	C148	B4	31-83	2	2-6 pF (red screw)	C103, C175
B1	20-96	2	36 pF	C166, C169	B4	31-71	2	3.2-18 pF (blue screw)	C117, C179
B1	20-78	3	56 pF	C118, C167, C168	B4	31-85	1	5-25 pF (violet screw)	C128
B1	20-147	1	75 pF	C119	INDUCTORS				
B1	20-148	3	100 pF	C116, C153, C155	C1	40-1616	2	.15 μH variable	L112, L113
B1	20-189	2	140 pF	C147, C149	C2	40-1869	1	1.31 μH toroid (grn dot)	L106
B1	20-103	3	150 pF	C135, C158, C161	C2	40-1874	1	3.8 μH toroid (blu dot)	L103
B1	20-114	2	270 pF	C134, C136	C2	40-1875	2	4.5 μH toroid (red-dot)	L114, L116
Ceramic					C2	40-1882	1	15.5 μH toroid (wht dot)	L115
B2	21-61	4	6.8 pF	C104, C129, C154, C174	C3	40-2065	1	4 μH	L102
B2	21-3	2	10 pF	C106, C132	C4	40-2068	1	6.5 μH	L105
B2	21-742	1	22 pF	C141	C5	40-2072	2	.9 μH	L107, L108
B2	21-7	2	33 pF	C109, C143	C5	40-2075	2	.44 μH	L109, L111
B2	21-85	3	56 pF	C139, C159, C178	C6	45-604	2	100 μH choke (brn-blk-brn)	L101, L104
B2	21-75	2	100 pF (100 k)	C112, C137	C5	52-182	5	IF transformer	T101, T102, T103, T104, T105
B2	21-140	13	.001 μF (1000 pF)	C102, C105, C108, C115, C121, C122, C124, C125, C131, C145, C164, C173, C176	DIODES				
B3	21-145	3	.001 μF feedthrough	C101, C126, C183	D1	56-24	6	1N458	D105, D106, D107, D108, D109, D111
					D1	56-26	2	1N191 (brn-wht-brn)	D102, D104
					D1	56-56	2	1N4149	D112, D113
					D2	56-648	1	MV109	D101
					D3	56-666	1	MV2115	D103

KEY No.	HEATH Part No.	QTY.	DESCRIPTION	CIRCUIT Comp. No.
---------	----------------	------	-------------	-------------------

TRANSISTORS - INTEGRATED CIRCUIT (IC)**NOTES:**

1. Transistors and integrated circuits may be marked for identification in any of the following four ways:
 - a. Part number.
 - b. Type number. (On integrated circuits, this refers only to the numbers; the letters may be different or missing.)
 - c. Part number and type number.
 - d. Part number with a type number other than the one listed.
2. Some of the ICs may be packed in conductive foam. Do not remove these ICs from the foam until a step directs you to install them.

E1	417-154	4	2N2369 transistor	Q103, Q106, Q107, Q113
----	---------	---	-------------------	---------------------------

KEY No.	HEATH Part No.	QTY.	DESCRIPTION	CIRCUIT Comp. No.
---------	----------------	------	-------------	-------------------

Transistors - Integrated Circuit (IC) (Cont'd)

E2	417-863	3	MFE131 transistor	Q109, Q111, Q112
E3	417-241	2	EL131 transistor	Q102, Q105
E3	417-169	2	MPF105 transistor	Q101, Q104
E3	417-801	3	MPSA20 transistor	Q116, Q118, Q119
E3	417-865	2	MPSA55 transistor	Q117, Q121
E3	417-134	2	MPS6520 transistor	Q114, Q115
E3	417-172	1	MPS6521 transistor	Q108
E4	442-96	1	MC1496G IC	U101

MISCELLANEOUS

	85-2753-1	1	Synthesizer circuit board
F1	206-1421	1	Circuit board shield
F2	206-1433	1	Coil shield
F3	258-5	1	Spring contact
F4	432-120	1	Circuit board connector
F5	432-121	8	Circuit board pin (includes one extra)
F6	432-1009	1	14-pin plug
F7	475-17	1	Ferrite core

STEP-BY-STEP ASSEMBLY

START

() Position the synthesizer circuit board printed side up as shown.

NOTE: When a wire is called for, cut the small white-violet solid wire to the specified length and remove 1/4" of insulation from each end. When you install a wire, position it over the heavy line on the board, insert the wire ends in the holes at each end of the line, and solder the wire ends to the foil. Then cut any excess wire ends.

() 1-1/4" wire.

() 1" wire.

() 1-3/4" wire.

() 2-1/4" wire.

() 2" wire.

() 7/8" wire.

() 1-1/4" wire.

() 1" wire.

() 1-5/8" wire.

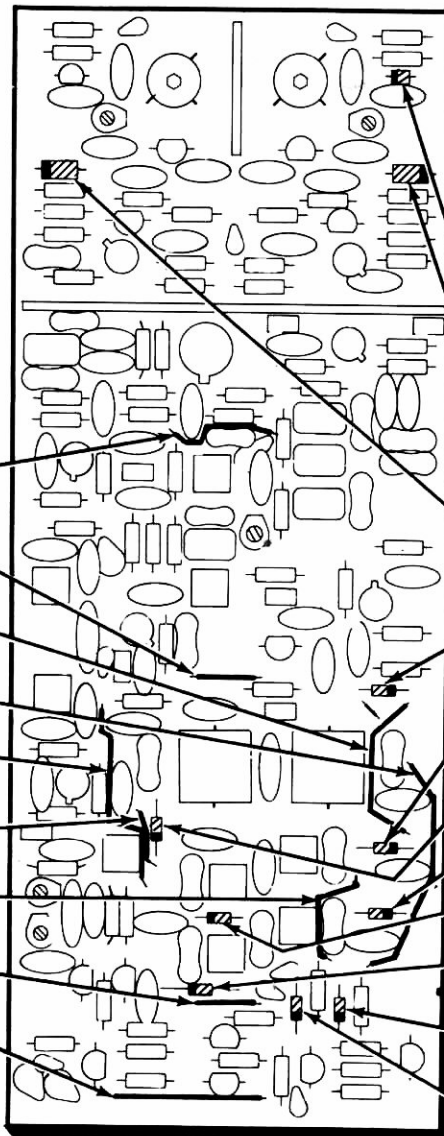

PICTORIAL 11-1

CONTINUE

CAUTION: Be sure the leads of parts DO NOT touch any of the wires already installed in the board; otherwise, when you solder the leads, the heat may melt the insulation, and cause a short circuit that would prevent the kit from working.

NOTE: DIODES MAY BE SUPPLIED IN ANY OF THE FOLLOWING SHAPES. ALWAYS POSITION THE BANDED END AS SHOWN ON THE CIRCUIT BOARD.

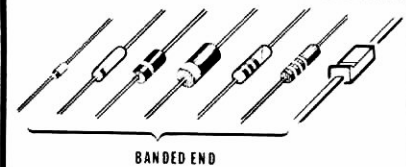

() D101: MV109 diode (#56-648).

() D102: 1N191 diode (#56-26, brn-wht-brn).

() D104: 1N191 diode (#56-26, brn-wht-brn).

() D111: 1N458 diode (#56-24).

() D108: 1N458 diode (#56-24).

() D109: 1N458 diode (#56-24).

() D106: 1N458 diode (#56-24).

() D107: 1N458 diode (#56-24).

() D105: 1N458 diode (#56-24).

() D112: 1N4149 diode (#56-56).

() D113: 1N4149 diode (#56-56).

Solder the leads to the foil and cut off the excess lead lengths.

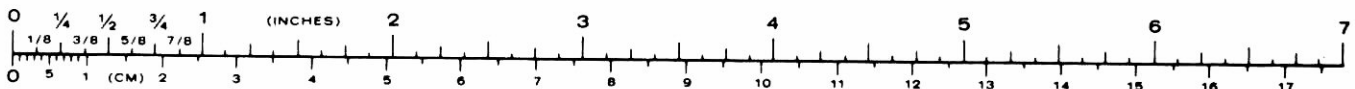

START 

- () R128: 1000Ω (brn-blk-red).
- () L104: 100μH choke (#45-604,brn-blk-brn).
- () R129: 82 kΩ (gry-red-org).
- () R133: 100 kΩ (brn-blk-yel).
- () R134: 4700 Ω (yel-viol-red).
- () R135: 47 Ω (yel-viol-blk).
- () R114: 1200 Ω (brn-red-red).
- () R136: 270 Ω (red-viol-brn).
- () R137: 100 Ω (brn-blk-brn).
- () R139: 100 kΩ (brn-blk-yel).
- () Solder the leads to the foil and cut off the excess lead lengths.
- () R141: 270 Ω (red-viol-brn).
- () R138: 100 Ω (brn-blk-brn).
- () R123: 1000 Ω (brn-blk-red).
- () R142: 5600 Ω (grn-blu-red).
- () R144: 270 Ω (red-viol-brn).
- () R162: 22 kΩ (red-red-org).
- () R165: 1 MΩ (brn-blk-grn).
- () R164: 10 kΩ (brn-blk-org).
- () R167: 100 kΩ (brn-blk-yel).
- () Solder the leads to the foil and cut off the excess lead lengths.

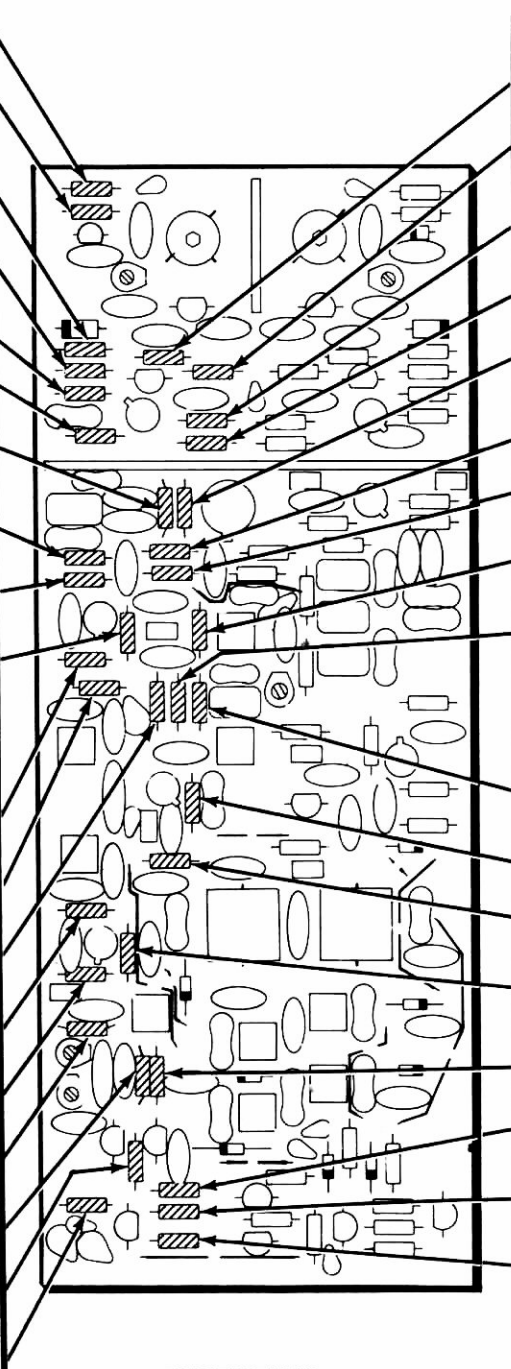

CONTINUE 

- () R132: 82 kΩ (gry-red-org).
- () R131: 100 Ω (brn-blk-brn).
- () R116: 560 Ω (grn-blu-brn).
- () R115: 10 kΩ (brn-blk-org).
- () R113: 47 Ω (yel-viol-blk).
- () R117: 560 Ω (grn-blu-brn).
- () R118: 100 Ω (brn-blk-brn).
- () R119: 100 Ω (brn-blk-brn).
- () R122: 1000 Ω (brn-blk-red).
- () Solder the leads to the foil and cut off the excess lead lengths.
- () R121: 3300 Ω (org-org-red).
- () R124: 390 Ω (org-wht-brn).
- () R125: 10 Ω (brn-blk-blk).
- () R143: 100 kΩ (brn-blk-yel).
- () R163: 1 MΩ (brn-blk-grn).
- () R145: 100 Ω (brn-blk-brn).
- () R166: 10 kΩ (brn-blk-org).
- () R175: 4700 Ω (yel-viol-red).
- () Solder the leads to the foil and cut off the excess lead lengths.

PICTORIAL 11-2

START

- () R104: 82 kΩ (gry-red-org).
 - () R103: 100 Ω (brn-blk-brn).
 - () R112: 820 Ω (gry-red-brn).
 - () R108: 100 Ω (brn-blk-brn).
 - () R159: 1000 Ω (brn-blk-red).
 - () R109: 100 Ω (brn-blk-brn).
 - () R111: 1000 Ω (brn-blk-red).
Form a loop in one of the resistor leads as shown. Then install the resistor so the loop is toward the left. NOTE: You will attach a wire to this loop later.
- LOOP

- () R156: 100 Ω (brn-blk-brn).
 - () Solder the leads to the foil and cut off the excess lead lengths.
 - () R155: 470 Ω (yel-viol-brn).
 - () R127: 100 Ω (brn-blk-brn).
 - () R153: 100 k Ω (brn-blk-yel).
 - () R126: 100 Ω (brn-blk-brn).
 - () R147: 100 Ω (brn-blk-brn).
 - () R172: 10 kΩ (brn-blk-org).
 - () R174: 47 kΩ (yel-viol-org).
 - () R173: 47 kΩ (yel-viol-org).
 - () Solder the leads to the foil and cut off the excess lead lengths.

CONTINUE

- () R101: 1000 Ω (brn-blk-red).
- () L101: 100 μH choke (#45-604, brn-blk-brn).
- () R102: 82 kΩ (gry-red-org).
- () R105: 100 kΩ (brn-blk-yel).
- () R106: 4700 Ω (yel-viol-red).
- () R107: 270 Ω (red-viol-brn).
- () R161: 270 Ω (red-viol-brn).
- () R158: 1000 Ω (brn-blk-red).
- () R157: 3300 Ω (org-org-red).
- () Solder the leads to the foil and cut off the excess lead lengths.
- () R154: 270 Ω (red-viol-brn).
- () R152: 100 kΩ (brn-blk-yel).
- () R146: 1000 Ω (brn-blk-red).
- () R149: 100 Ω (brn-blk-brn).
- () R168: 10 kΩ (brn-blk-org).
- () R171: 4700 Ω (yel-viol-red).
- () R169: 47 kΩ (yel-viol-org).
- () Solder the leads to the foil and cut off the excess lead lengths.

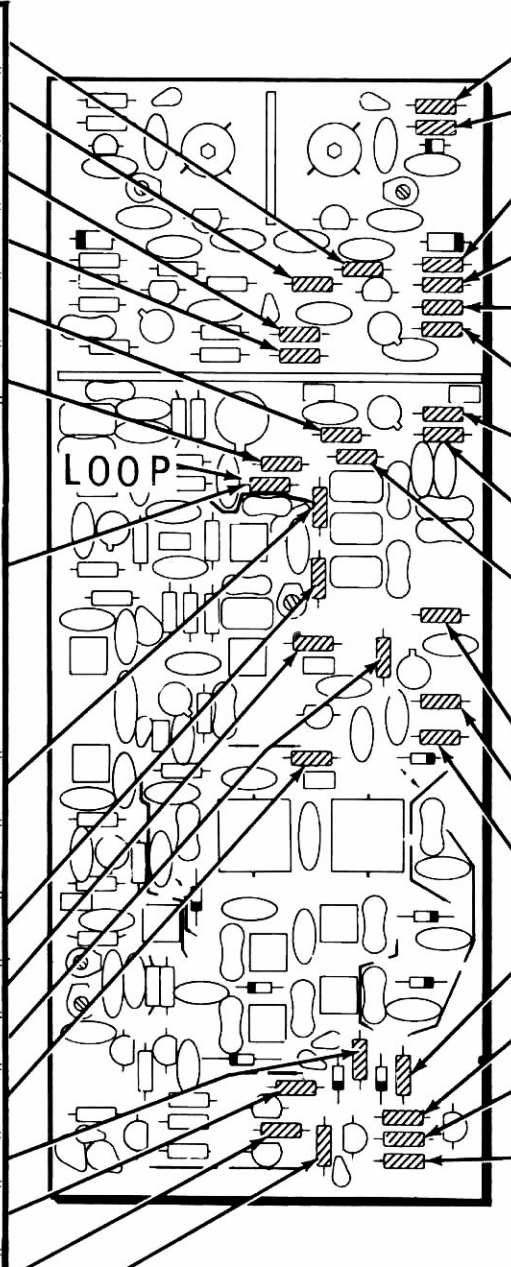

PICTORIAL 11-3

START 

When you install a trimmer capacitor, align its flat end with the flat on the circuit board, insert the leads into their holes and solder the leads to the foil.

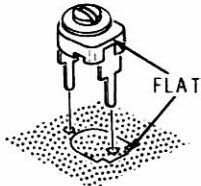

() C128: 5-25 pF trimmer (violet screw).

() C103: 2-6 pF trimmer (red screw).

() C117: 3.2-18 pF trimmer (blue screw).

When you install a circuit board pin, push its short end into the board hole so the ridge on the pin is against the board. Then solder the pin to the foil.

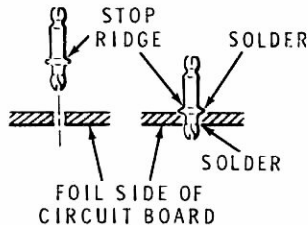

() Circuit board pin in hole 8A.

() C175: 2-6 pF trimmer (red screw).

() C179: 3.2-18 pF trimmer (blue screw).

() Circuit board pins in holes A,B, and C.

() Circuit board pins in holes D, 12B and 12C.

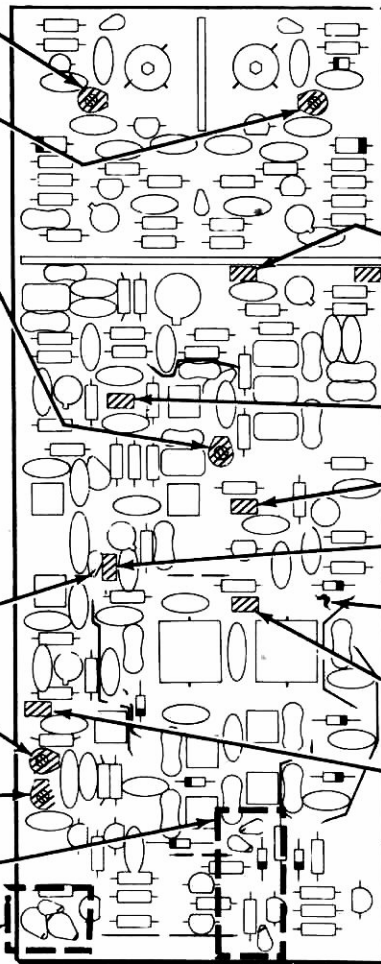

CONTINUE 

() Locate the 14-pin plug and carefully cut it into seven 2-pin plugs. Use small diagonal cutters.

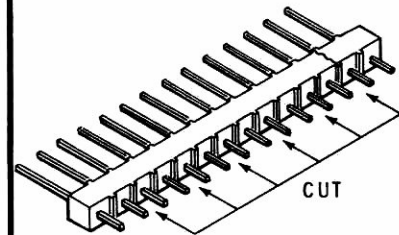

When you install the plugs in the following steps, push the short pins as far as possible into their holes in the board and solder them to the foil.

() 2-pin plug at P105.

() 2-pin plug at P101.

() 2-pin plug at P106.

() 2-pin plug at P104.

() 2-pin plug at P102.

() 3/4" small bare wire. Solder the leads to the foil and cut off the excess lead lengths.

() 2-pin plug at P103.

() 2-pin plug at P107.

PICTORIAL 11-4

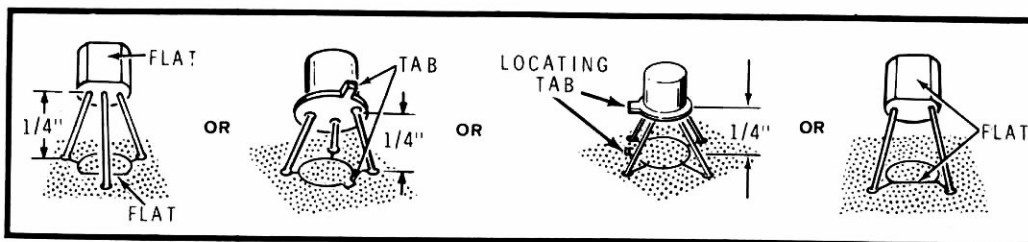

START

When you install a diode or transistor in the following steps, align its flat with the flat on the board, or its tab with the tab on the board. Insert the leads into their holes and position the diode or transistor 1/4" from the board. Then solder the leads to the foil and cut off the excess lead lengths. See Detail 11-5A.

() D103: MV2115 diode (#56-666).

() Q104: MPF105 transistor (#417-169).

() Q105: EL131 transistor (#417-241).

() Q106: 2N2369 transistor (#417-154).

() Q109: MFE131 transistor (#417-863).

() Q107: 2N2369 transistor (#417-154).

() Q111: MFE131 transistor (#417-863).

() Q114: MPS6520 transistor (#417-134).

() Q115: MPS6520 transistor (#417-134).

() Q121: MPSA55 transistor (#417-865).

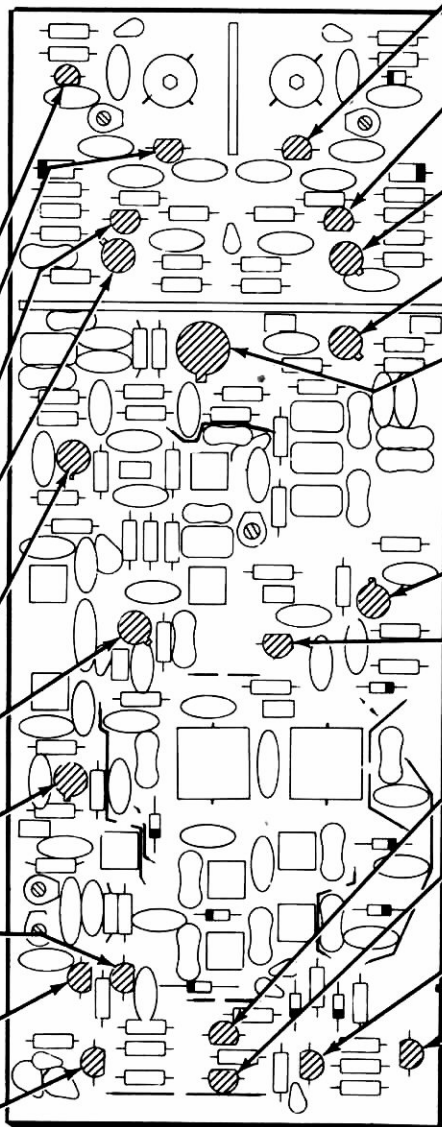

CONTINUE

() Q101: MPF105 transistor (#417-169).

() Q102: EL131 transistor (#417-241).

() Q103: 2N2369 transistor (#417-154).

() Q113: 2N2369 transistor (#417-154).

() U101: MC1496G IC (#442-96). Align the tab with the tab on the board, insert its leads into their holes, and position it 1/4" above the board. Then solder its leads to the foil and cut off the excess lead lengths.

() Q112: MFE131 transistor (#417-863).

() Q108: MPS6521 transistor (#417-172).

() Q118: MPSA20 transistor (#417-801).

() Q119: MPSA20 transistor (#417-801).

() Q117: MPSA55 transistor (#417-865).

() Q116: MPSA20 transistor (#417-801).

PICTORIAL 11-5



START ↘

When you install an inductor, insert the pins as far as possible into their correct holes and solder the pins to the foil, cut off any excess lead lengths.

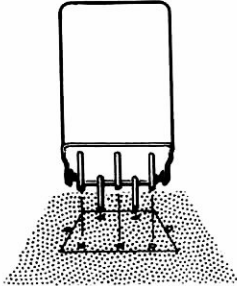

- () T101: IF transformer (#52-182).
- () T102: IF transformer (#52-182).
- () T103: IF transformer (#52-182).
- () T104: IF transformer (#52-182).
- () L111: .44 μ H inductor (#40-2075).
- () L109: .44 μ H inductor (#40-2075).
- () T105: IF transformer (#52-182).
- () L108: .9 μ H inductor (#40-2072).
- () L107: .9 μ H inductor (#40-2072).

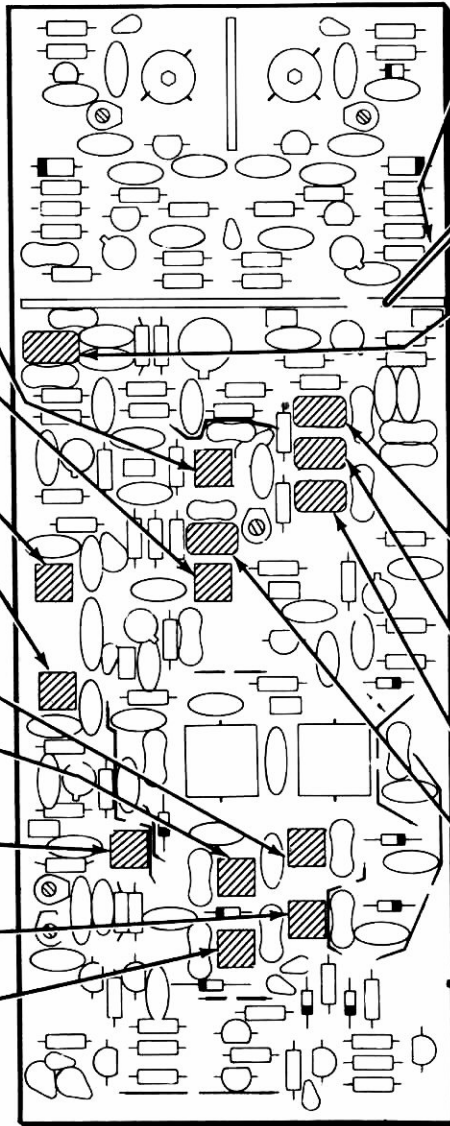

CONTINUE ↘

() 1" small bare wire. Keep 3/4" above the board.

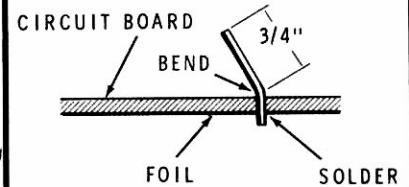

Solder the leads to the foil and cut off the excess lead lengths as you install each of the following coils.

() L106: 1.31 μ H (grn dot) toroid coil (#40-1869). Push the coil tight against the board.

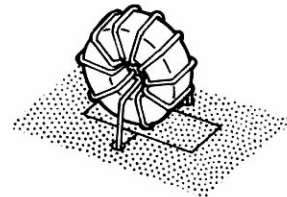

- () L116: 4.5 μ H (red dot) toroid coil (#40-1875).
- () L115: 15.5 μ H (wht dot) toroid coil (#40-1882).
- () L114: 4.5 μ H (red dot) toroid coil (#40-1875).
- () L103: 3.8 μ H (blu dot) toroid coil (#40-1874).

PICTORIAL 11-6

START

- () C129: 6.8 pF ceramic.
- () C131: .001 μ F (1000pF) ceramic.
- () C134: 270 pF mica.
- () C135: 150 pF mica.
- () C113: .01 μ F ceramic.
- () C112: 100 pF (100 K) ceramic.
- () C136: 270 pF mica.
- () C137: 100 pF (100 K) ceramic.
- () Solder the leads to the foil and cut off the excess lead lengths.
- () C144: .01 μ F ceramic.
- () C138: .01 μ F ceramic.
- () C143: 33 pF ceramic.
- () C139: 56 pF ceramic.
- () C182: .05 μ F ceramic.
- () C141: 22 pF ceramic.
- () C146: .01 μ F ceramic.
- () C174: 6.8 pF ceramic.
- () C178: 56 pF ceramic.
- () C181: .1 μ F ceramic.
- () Solder the leads to the foil and cut off the excess lead lengths.

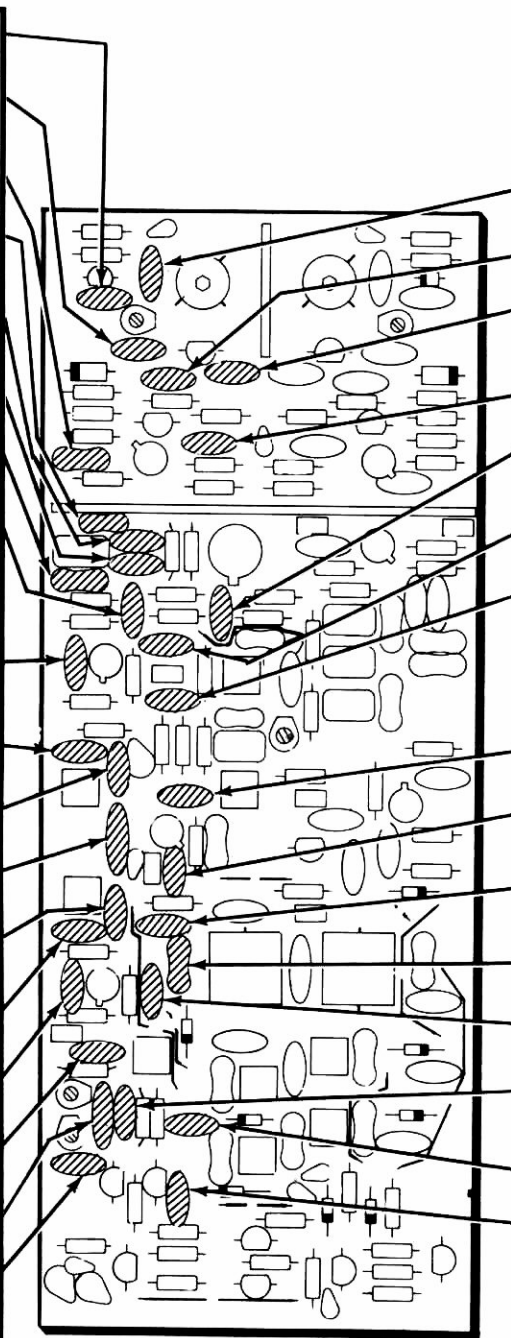

CONTINUE

- () C127: .01 μ F ceramic.
- () C132: 10 pF ceramic.
- () C133: .01 μ F ceramic.
- () C111: .01 μ F ceramic.
- () C115: .001 μ F (1000pF) ceramic.
- () C142: .01 μ F ceramic.
- () C114: .01 μ F ceramic.
- () Solder the leads to the foil and cut off the excess lead lengths.
- () C121: .001 μ F (1000pF) ceramic.
- () C122: .001 μ F (1000pF) ceramic.
- () C123: .01 μ F ceramic.
- () C158: 150 pF mica.
- () C145: .001 μ F (1000pF) ceramic.
- () C176: .001 μ F (1000pF) ceramic.
- () C151: .05 μ F ceramic.
- () C177: .1 μ F ceramic.
- () Solder the leads to the foil and cut off the excess lead lengths.

PICTORIAL 11-7

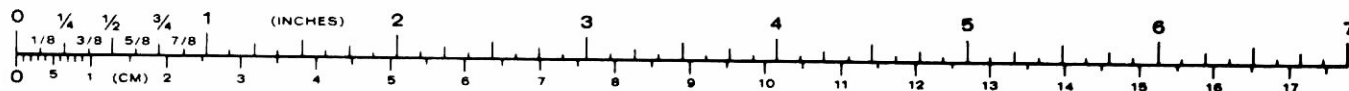

START ↘

- C107: .01 μ F ceramic.
- C109: 33 pF ceramic.
- C173: .001 μ F (1000pF) ceramic.
- C116: 100 pF mica.
- C174: .1 μ F ceramic.
- C118: 56 pF mica.
- C125: .001 μ F (1000pF) ceramic.
- C119: 75 pF mica.
- Solder the leads to the foil and cut off the excess lead lengths.
- C124: .001 μ F (1000pF) ceramic.
- C162: .05 μ F ceramic.
- C159: 56 pF ceramic.
- C156: .05 μ F ceramic.
- C153: 100pF mica.
- C154: 6.8 pF ceramic.
- C147: 140 pF mica.
- C148: 12 pF mica.
- C149: 140 pF mica.
- Solder the leads to the foil and cut off the excess lead lengths.

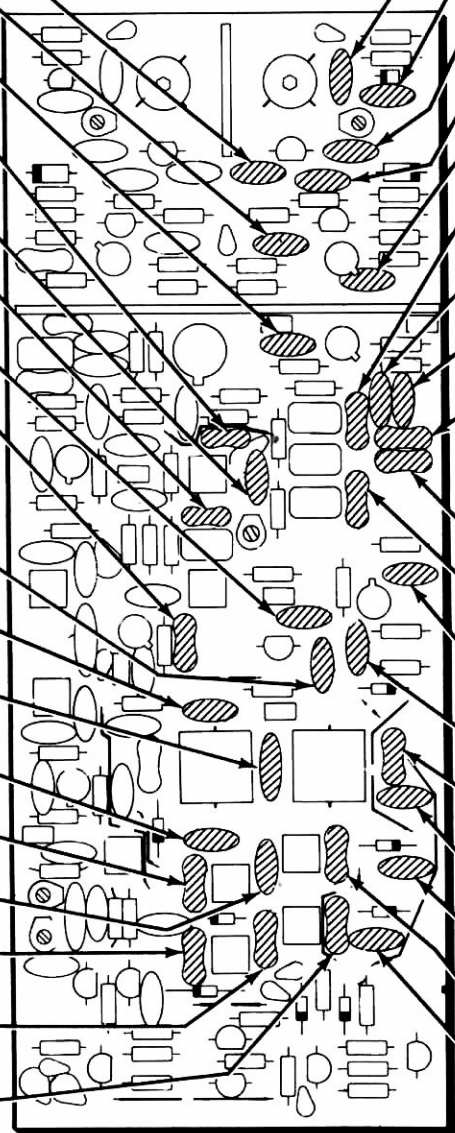

CONTINUE ↙

- C102: .001 μ F (1000pF) ceramic.
- C104: 6.8 pF ceramic.
- C105: .001 μ F (1000pF) ceramic.
- C106: 10 pF ceramic.
- C108: .001 μ F (1000pF) ceramic.
- C169: 36 pF mica.
- C171: .1 μ F ceramic.
- C172: .1 μ F ceramic.
- C168: 56 pF mica.
- Solder the leads to the foil and cut off the excess lead lengths.
- C167: 56 pF mica.
- C166: 36 pF mica.
- C165: .01 μ F ceramic.
- C164: .001 μ F (1000pF) ceramic.
- C161: 150 pF mica.
- C163: .05 μ F ceramic.
- C157: .05 μ F ceramic.
- C155: 100 pF mica.
- C152: .05 μ F ceramic.
- Solder the leads to the foil and cut off the excess lead lengths.

PICTORIAL 11-8

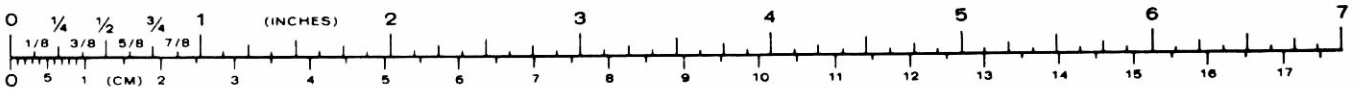

START

NOTE: Solder the wires or pins as you install each wire or part in this Pictorial.

When you install a coil, push its pins as far as possible into the board holes before you solder them.

- () L102: 4 μ H coil (#40-2065).
- () L105: 6.5 μ H coil (#40-2068).

- () Coil shield. Insert the tabs into the board holes and solder the tabs to the foil. Position the shield straight up from the board.

COIL SHIELD

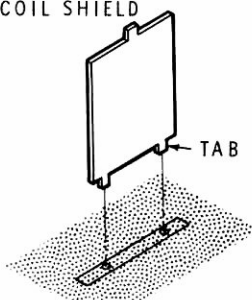

When a stranded wire is called for in a step, cut the indicated color stranded wire to the specified length and remove 1/4" of insulation from both ends. Twist together the fine wire strands and melt a small amount of solder on the exposed wire ends.

- () Prepare a 3" small yellow stranded wire. Then solder one end of the wire in circuit board hole 8B. The other end will be connected later.

- () Install a circuit board connector on one end of a 6" small orange stranded wire.

BEND OVER BARE WIRE END AND SOLDER

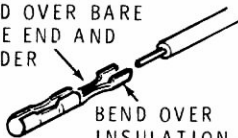

BEND OVER INSULATION AFTER CONNECTOR IS COOL

- () Push the connector on the pin at 12C and solder the wire end in hole 12A.

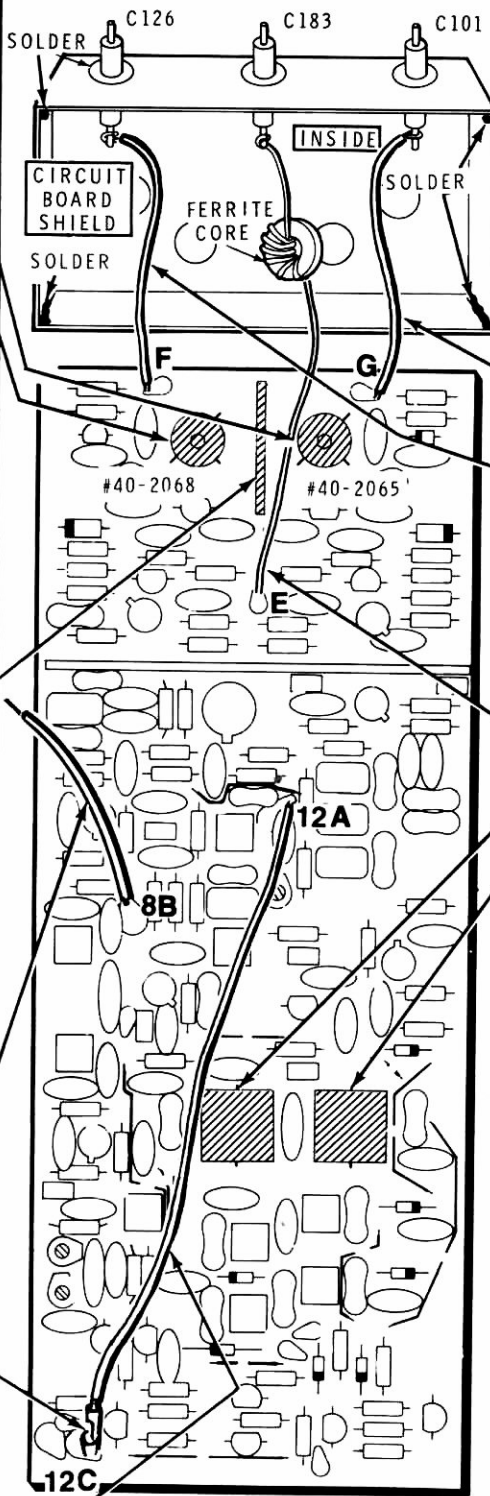

PICTORIAL 11-9

CONTINUE

- () Apply solder all along the four seams of the circuit board shield as shown.
- () Melt solder around the three small holes in the side of the circuit board shield.
- () C126, C183, and C101. Solder a .001 μ F feedthrough capacitor into each of these holes.
- () 3-1/2" small white stranded wire from C101 to board hole G.
- () 3-1/2" small white stranded wire from C126 to board hole F.
- () Start 1" from one end of an 8" small white stranded wire and tightly wrap 6-turns of the wire on a ferrite core (#475-17).
- () Connect this assembly from C183 to board hole E.
- () L113: .15 μ H coil (#40-1616).
- () L112: .15 μ H coil (#40-1616).

NOTE: The circuit board shield will be mounted later.

CIRCUIT BOARD CHECKOUT

Carefully inspect the circuit board for the following conditions.

- () Unsoldered connections.
- () Poor solder connections.
- () Solder bridges between foil patterns.
- () Protruding leads which could touch together.
- () Transistors and the IC for the proper type and installation.
- () Diodes for the correct position of the banded end.

Refer to Pictorial 11-10 (Illustration Booklet, Page 14) for the following steps.

- () Position the synthesizer circuit board foil-side-up as shown in the Pictorial.
- () Solder the spring contact to the foil at the indicated location. (This foil is at one end of the coil shield that was previously mounted on the component side of the circuit board.) Be sure to position the spring contact as shown in the Pictorial. Hold the spring contact with pliers so you do not burn your fingers.

INITIAL TESTS

NOTE: In the following steps, the setting of your ohmmeter is indicated in parentheses, "(R × 10K)" for example, because meaningful readings cannot be taken using a single range. Be sure to zero your ohmmeter each time you change its range.

Refer to Pictorial 11-11 for the following steps.

- () Connect the common ohmmeter lead to a ground point on the synthesizer circuit board foil. NOTE: A convenient point is the coil shield on top of the circuit board.

Use the positive ohmmeter probe to check the synthesizer circuit board plugs and pins for the following readings. Note that, as on the previous circuit boards, the steps are abbreviated.

NOTE: Do not change ohmmeter ranges unless a step directs you to do so.

- () Circuit board pin A. 5000 Ω to 10 kΩ. Check D113, C157, C181. (R × 1000).
- () Circuit board pin B. 5000 Ω to 10 kΩ. Check D112, C163.
- () Circuit board pin C. Approximately 70 kΩ. Check Q117. (R × 10K).
- () Circuit board pin D. 30 kΩ to 100 kΩ. Check Q121.

- () Circuit board pins 12B & 12C. 300 Ω to 1000 Ω with the orange wire connected. Check Q118, Q119, Q121. (R × 100).

- () Circuit board pin 8A. 500 Ω to 1000 Ω. Check the 8-volt DC circuits (see the Schematic). (R × 100).

- () Wire coming from hole 8B. 500 Ω. Check the 8-volt DC circuits (see the Schematic).

NOTE: When you check the following feedthrough capacitors, check for the resistances on the inner end of each capacitor (the point that is wired directly to the circuit board).

- () Capacitor C126. Infinity. Check C126, D103, C127. (R × 10K).

- () Capacitor C101. Infinity. Check C101, D101, C102.

- () Capacitor C183. 50 Ω to 300 Ω. Check C183, 8-volt DC circuits. (R × 10).

- () P101-1. Infinity. Check C108, Q103. (R × 10K).

- () P102-1. 1000 Ω to 2000 Ω. Check Q107, C114. (R × 1000).

- () P103-1. Infinity. Check C124, Q108. (R × 10K).

- () P104-1. Approximately 100 Ω. Check C125, Q108. (R × 10).

- () P105-1. Infinity. Check C173, Q113. (R × 10K).

- () P106-1. Infinity. Check C142, Q109. (R × 10K).

- () P107-1. Infinity. Check C174. (R × 10K).

This completes the "Initial Tests" of your synthesizer circuit board. Set the circuit board aside until it is called for during the assembly of the chassis. Proceed to "RF Circuit Board".

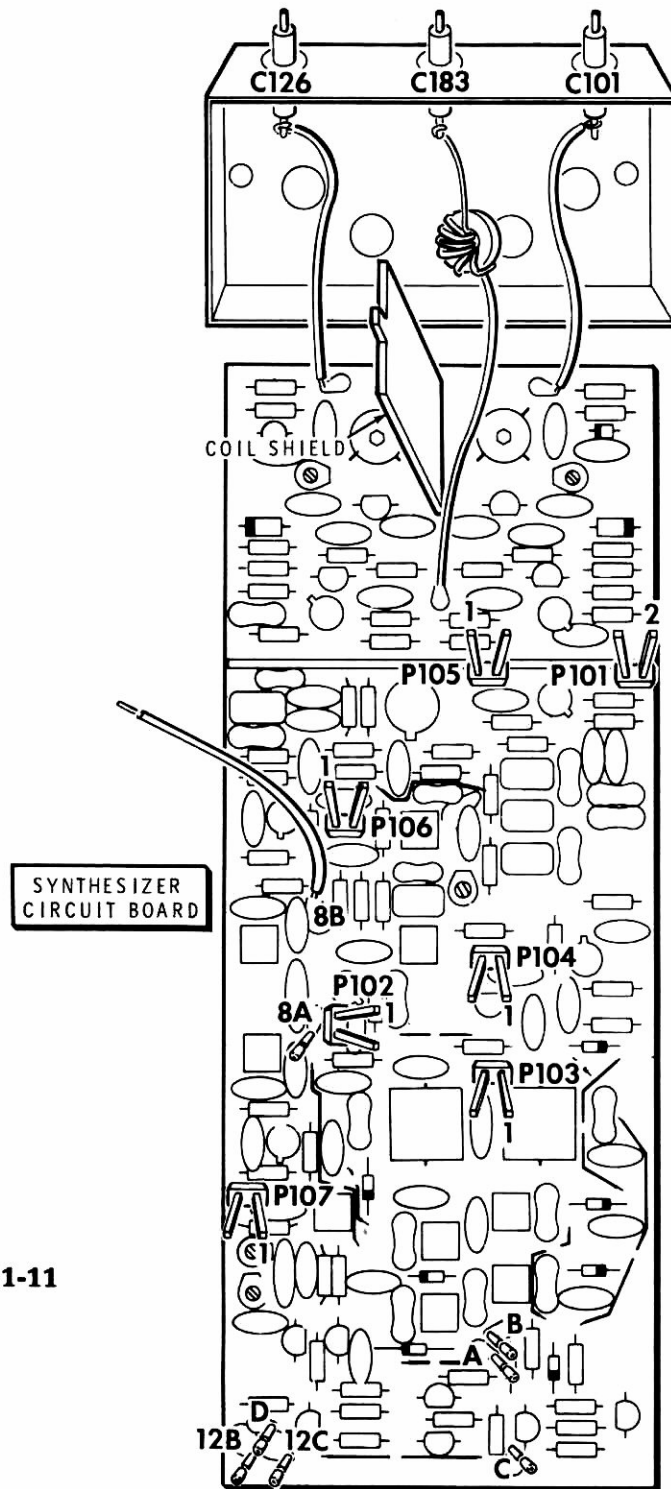

PICTORIAL 11-11

RF CIRCUIT BOARD

PARTS LIST

() Refer to the Pack Index Sheet and locate Pack #12. Then remove the parts from this pack and check each part against the following list. The key numbers correspond to the numbers on the "RF Circuit Board Parts Pictorial" (Illustration Booklet, Page 13). Return any part that is packed in an individual envelope, with the part number on it, back into its envelope until that part is called for in a step. Do not throw away

any packing material until you account for all the parts.

To order a replacement part, always include the PART NUMBER. Use the Parts Order Form furnished with this kit. If a Parts Order Form is not available, refer to "Replacement Parts" inside the rear cover of this Manual. For prices, refer to the separate "Heath Parts Price List."

KEY No.	HEATH Part No.	QTY.	DESCRIPTION	CIRCUIT Comp. No.
---------	----------------	------	-------------	-------------------

KEY No.	HEATH Part No.	QTY.	DESCRIPTION	CIRCUIT Comp. No.
---------	----------------	------	-------------	-------------------

RESISTORS

Resistors (Cont'd)

NOTES:

- Resistors may be packed in more than one envelope. Open all of the resistor envelopes in this pack before you check the resistors against the following Parts List.
- The following resistors are rated at 1/4-watt and have a tolerance of 5% (fourth band gold) unless otherwise listed.

A2	6-222-12	1	2200 Ω (red-red-red)	R415
A2	6-332-12	2	3300 Ω (org-org-red)	R411, R418
A2	6-392-12	1	3900 Ω (org-wht-red)	R402
A2	6-472-12	1	4700 Ω (yel-viol-red)	R408
A2	6-822-12	2	8200 Ω (gry-red-red)	R406, R429
A2	6-103-12	4	10 kΩ (brn-blk-org)	R421, R436, R437, R439
A2	6-223-12	4	22 kΩ (red-red-org)	R428, R435, R438, R447
A2	6-333-12	1	33 kΩ (org-org-org)	R416
A2	6-473-12	1	47 kΩ (yel-viol-org)	R401
A2	6-823-12	1	82 kΩ (gry-red-org)	R446
A2	6-104-12	3	100 kΩ (brn-blk-yel)	R419, R449, R451
A2	6-474-12	1	470 kΩ (yel-viol-yel)	R422

CAPACITORS

Mica

B1	20-101	3	47 pF	C453, C455, C457
----	--------	---	-------	------------------

A1	6-100	1	10 Ω, 1/2-watt (brn-blk-blk)	R443
A2	6-220-12	2	22 Ω (red-red-blk)	R404, R405
A2	6-101-12	9	100 Ω (brn-blk-brn)	R403, R407, R424, R427, R431, R432, R442, R445, R452
A2	6-151-12	1	150 Ω (brn-gm-brn)	R425
A2	6-271-12	2	270 Ω (red-viol-brn)	R417, R423
A2	6-471-12	1	470 Ω (yel-viol-brn)	R434
A2	6-681-12	2	680 Ω (blu-gry-brn)	R412, R414
A2	6-102-12	4	1000 Ω (brn-blk-red)	R426, R433, R441, R448

KEY No.	HEATH Part No.	QTY.	DESCRIPTION	CIRCUIT Comp. No.	KEY No.	HEATH Part No.	QTY.	DESCRIPTION	CIRCUIT Comp. No.
Capacitors (Cont'd)					Capacitors (Cont'd)				
Ceramic					Electrolytic				
B2	21-33	3	3.3 pF	C442, C454, C456	B4	25-858	1	.33 μ F	C489
B2	21-756	2	3.9 pF	C445, C447	B4	25-925	1	4.7 μ F	C418
B2	21-78	1	5 pF	C492	B4	25-931	2	10 μ F	C421, C424
B2	21-169	2	6 pF	C438, C485	INDUCTORS				
B2	21-115	2	9 pF	C435, C483	C1	40-2076	2	.3 μ H variable	L425, L427
B2	21-3	1	10 pF	C465	C2	40-2078	3	.35 μ H variable (black)	L405, L435, L437
B2	21-770	2	12 pF	C429, C432	C1	40-2074	2	.57 μ H variable	L432, L434
B2	21-5	1	20 pF	C467	C1	40-2073	3	.71 μ H variable	L428, L429, L431
B2	21-84	2	24 pF	C427, C482	C1	40-2072	3	.9 μ H variable	L422, L423, L424
B2	21-7	1	33 pF	C405	C2	40-2077	1	.53 μ H variable (yellow)	L436
B2	21-788	3	110 pF (111)	C444, C446, C448	C1	40-2071	3	1.5 μ H variable	L418, L419, L421
B2	21-787	5	150 pF (151)	C437, C439, C441, C443, C486	C3	40-1792	2	1.8 μ H toroid	L402, L403
B2	21-746	8	180 pF (181)	C428, C431, C433, C434, C436, C449, C452, C484	C4	45-73	2	2.2 μ H choke (red-red-gold)	L411, L442
B2	21-56	1	470 pF	C475	C1	40-2070	3	3 μ H variable	L415, L416, L417
B2	21-171	1	680 pF	C403	C3	40-1726	1	7 μ H toroid	L404
B2	21-140	4	.001 μ F (1000 pF)	C407, C422, C473, C474	C1	40-2069	3	13 μ H variable	L412, L413, L414
B2	21-25	2	.0013 μ F (1300 pF)	C402, C404	C4	45-604	13	100 μ H choke (brn-blk-brn)	L401, L406, L407, L408, L409, L438, L439, L441, L443, L444, L445, L446, L447
B2	21-176	24	.01 μ F	C401, C408, C412, C413, C414, C416, C417, C419, C425, C426, C458, C459, C462, C463, C466, C469, C471, C472, C476, C477, C478, C488, C491, C494	DIODES				
B2	21-143	12	.05 μ F	C409, C411, C423, C461, C464, C466, C468, C479, C481, C487, C492, C493	D1	56-56	20	1N4149	D401, D402, D403, D404, D405, D407, D408, D409, D410, D411, D413, D414, D416, D418, D421, D422, D423, D424, D425, D426
B2	21-192	1	.1 μ F (104M)	C415	D1	56-58	1	1N5234B	D427
B3	31-85	1	5-25 pF trimmer (violet screw)	C406	D1	56-621	1	VR-8.2	D406
					D1	56-646	1	BA-244 (red-yel-yel)	D412

KEY No.	HEATH Part No.	QTY.	DESCRIPTION	CIRCUIT Comp. No.
---------	----------------	------	-------------	-------------------

KEY No.	HEATH Part No.	QTY.	DESCRIPTION	CIRCUIT Comp. No.
---------	----------------	------	-------------	-------------------

TRANSISTORS

NOTE: Transistors may be marked for identification in any of the following four ways:

1. Part number.
2. Type number.
3. Part number and type number.
4. Part number with a type number other than the one listed.

E1	417-205	1	2N3866	Q403
E2	417-801	3	MPSA20	Q406, C408, Q409
E2	417-865	2	MPSA55	Q407, C412
E2	417-134	1	MPS6520	Q411
E2	417-172	3	MPS6521	Q401, Q402, Q405
E3	417-863	1	MFE131	Q404

MISCELLANEOUS

F1	63-1386	3	Rotary switch	SW401A, SW401B, SW401C
	85-2683-1	1	RF circuit board	
F2	150-72	2	Double-balanced mixer	U401, U402
F3	206-1427	2	Shield plate	
F4	206-1429	1	Small shield	
F5	206-1432	1	Shield plate cover	
F6	215-45	1	Round transistor heatsink	
F7	250-1412	2	4-40 × 3/8" black phillips head screw	
F8	250-365	2	#6 × 1/4" hex head sheet metal screw	
F9	252-15	2	Small 4-40 nut	
F10	254-9	2	#4 lockwasher	
	344-132	24"	Small violet stranded wire	
F11	432-969	7	5-pin plug	P401, P403, P407, P408, P409, P410, P411
F12	432-1265	4	3-pin plug	P402, P404, P405, P406
F13	475-10	4	Ferrite bead	
F14	475-24	3	Ferrite core	
F15	490-185	1	Package of desoldering braid	

STEP-BY-STEP ASSEMBLY

START

() Position the RF circuit board printed side (not the foil side) up as shown. NOTE: Not all of the circuit board will be shown in all the Pictorials. Refer to the identification drawing at the top of the page to see what area of the circuit board is to be worked on.

When a wire is called for, cut the small white-violet solid wire to the specified length and remove 1/4" of insulation from each end. When a bare wire is called for, use the small bare wire supplied with the kit.

() 1" bare wire.

() 1-3/4" wire.

() 1-1/8" wire.

() 1-3/4" wire.

() 2-1/4" wire.

() 3" wire.

() 3/4" wire.

() 3/4" wire.

() 2-1/4" wire.

() 2-7/8" wire.

() 3-1/2" wire.

() 1-1/8" wire.

() Solder the leads to the foil and cut off the excess lead lengths.

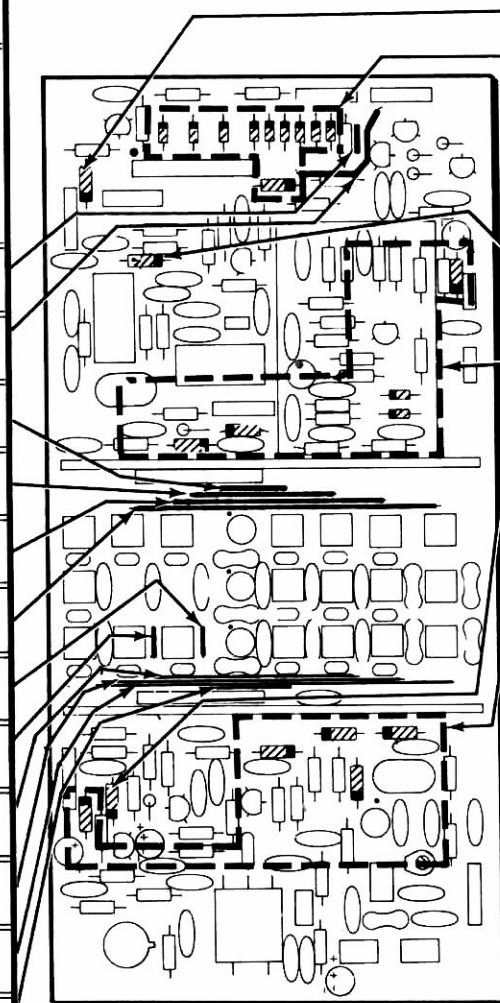

PICTORIAL 12-1

CONTINUE

NOTE: DIODES MAY BE SUPPLIED IN ANY OF THE FOLLOWING SHAPES ALWAYS POSITION THE BANDED END AS SHOWN ON THE CIRCUIT BOARD.

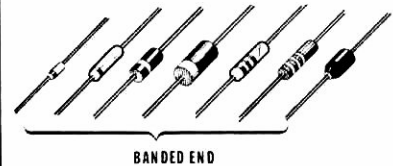

() D427: 1N5234B diode (#56-58).

() Ten 1N4149 diodes (#56-56) at D414, D416, D418, D424, D423, D422, D426, D425, D413, and D421. Solder their leads to the foil and cut off their excess lead lengths.

() D412: BA-244 diode (#56-646, red-yel-yel).

() Five 1N4149 diodes (#56-56) at D410, D411, D409, D407, D408

() D406: VR-8.2 diode (#56-621).

() Five 1N4149 diode (#56-56) at D402, D403, D404, D401, and D405.

Solder the leads to the foil and cut off the excess lead lengths.

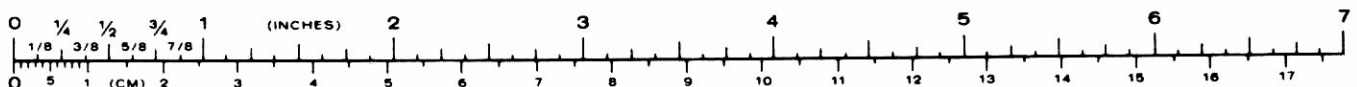

The steps performed in this Pictorial are in this area of the circuit board.

START

- () R439: 10 kΩ (brn-blk-org).
- () L447: 100μH choke (#45-604, brn-blk-brn).
- () R441: 1000Ω (brn-blk-red).
- () R433: 1000Ω (brn-blk-red).
- () L445: 100 μH choke (#45-604, brn-blk-brn).

When a ferrite bead is called for, cut a 1" length of small bare wire, insert it through the ferrite bead, and install the bead like a resistor.

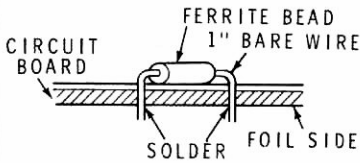

- () Ferrite bead.
- () R452: 100 Ω (brn-blk-brn).
- () Solder the leads to the foil and cut off the excess lead lengths.
- () L446: 100μH choke (#45-604, brn-blk-brn).
- () L406: 100 μH choke (#45-604, brn-blk-brn).
- () Ferrite bead.
- () R417: 270 Ω (red-viol-brn).
- () R416: 33 kΩ (org-org-org).
- () R415: 2200 Ω (red-red-red).
- () R414: 680 Ω (blu-gry-brn).

- () Solder the leads to the foil and cut off the excess lead lengths.

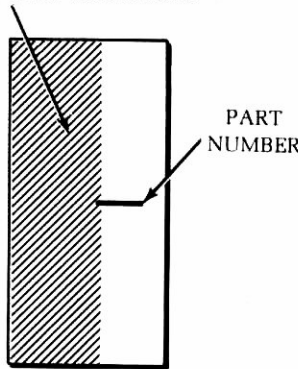

IDENTIFICATION DRAWING

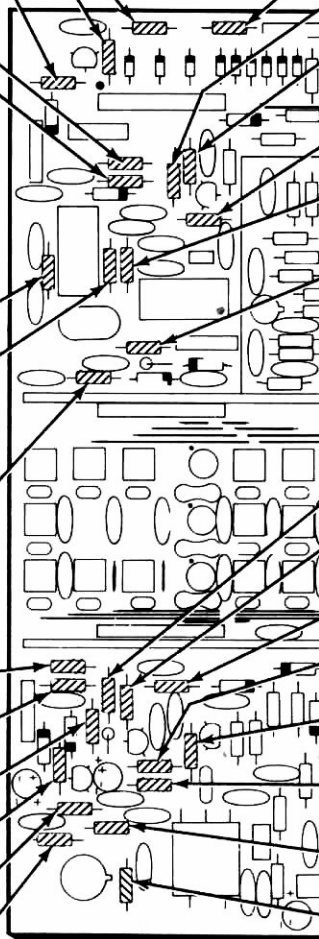

PICTORIAL 12-2

CONTINUE

- () R451: 100 kΩ (brn-blk-yel).
- () R432: 100 Ω (brn-blk-brn).
- () R428: 22 kΩ (red-red-org).
- () L444: 100 μH choke (#45-604, brn-blk-brn).
- () R434: 470 Ω (yel-viol-brn).
- () L438: 100 μH choke (#45-604, brn-blk-brn).
- () Solder the leads to the foil and cut off the excess lead lengths.
- () R403: 100 Ω (brn-blk-brn).
- () R402: 3900 Ω (org-wht-red).
- () L408: 100 μH choke (#45-604, brn-blk-brn).
- () R405: 22 Ω (red-red-blk).
- () R407: 100 Ω (brn-blk-brn).
- () L407: 100 μH choke (#45-604, brn-blk-brn).
- () R412: 680 Ω (blu-gry-brn).
- () R443: 10 Ω, 1/2 watt (brn-blk-blk).
- () Solder the leads to the foil and cut off the excess lead lengths.

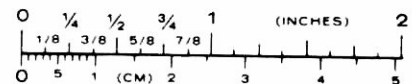

The steps performed in this Pictorial are in this area of the circuit board.

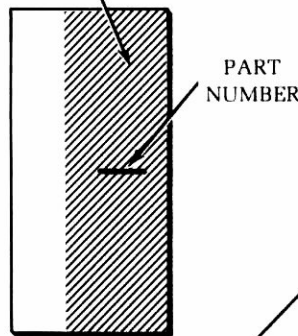

IDENTIFICATION DRAWING

START ↘

- () R431: 100 Ω (brn-blk-brn).
- () R429: 8200 Ω (gry-red-red).
- () L441: 100 μH choke (#45-604, brn-blk-brn).
- () R424: 100 Ω (brn-blk-brn).
- () R422: 470 kΩ (yel-viol-yel).
- () R446: 82 kΩ (gry-red-org).
- () R423: 270 Ω (red-viol-brn).
- () R425: 150 Ω (brn-grn-brn).
- () Solder the leads to the foil and cut off the excess lead lengths.
- () R419: 100 kΩ (brn-blk-yel).
- () R421: 10 kΩ (brn-blk-org).
- () L439: 100 μH choke (#45-604, brn-blk-brn).
- () R408: 4700 Ω (yel-viol-red).
- () R406: 8200 Ω (gry-red-red).
- () R411: 3300 Ω (org-org-red).
- () Ferrite bead.
- () L411: 2.2 μH choke (#45-73, red-red-gold).
- () Solder the leads to the foil and cut off the excess lead lengths.

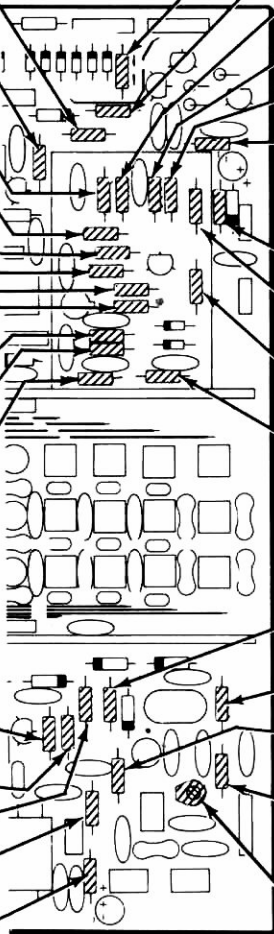

PICTORIAL 12-3

CONTINUE ↘

- () R449: 100 kΩ (brn-blk-yel).
- () R435: 22 kΩ (red-red-org).
- () R426: 1000 Ω (brn-blk-red).
- () L442: 2.2 μH choke (#45-73, red-red-gold).
- () R427: 100 Ω (brn-blk-brn).
- () L443: 100 μH choke (#45-604, brn-blk-brn).
- () Solder the leads to the foil and cut off the excess lead lengths.
- () R448: 1000 Ω (brn-blk-red).
- () R447: 22 kΩ (red-red-org).
- () Ferrite bead.
- () R445: 100 Ω (brn-blk-brn).
- () R401: 47 kΩ (yel-viol-org).
- () L401: 100 μH choke (#45-604, brn-blk-brn).
- () L409: 100 μH choke (#45-604, brn-blk-brn).
- () R442: 100 Ω (brn-blk-brn).
- () Solder the leads to the foil and cut off the excess lead lengths.
- () C406: 5-25 μF trimmer (#31-85). Align the flat on the trimmer with the flat on the board and insert the leads into their holes. Then solder the leads to the foil.

START 

When you install a double balanced mixer, be sure its number 1 pin goes into the number 1 hole in the circuit board. Then solder all eight pins to the foil and cut off the excess pin lengths.

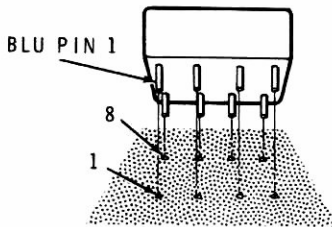

() U402: MCL SBL-1 double-balanced mixer (#150-72).

() U401: MCL SBL-1 double-balanced mixer (#150-72).

NOTE: Mount each of the following resistors vertically. Solder the longer lead first. Then straighten the resistor, solder the other lead, and cut off the excess lead lengths.

() R418: 3300 Ω (org-org-red).

() R437: 10 kΩ (brn-blk-org).

() R436: 10 kΩ (brn-blk-org).

() R438: 22 kΩ (red-red-org).

() R404: 22 Ω (red-red-blk).

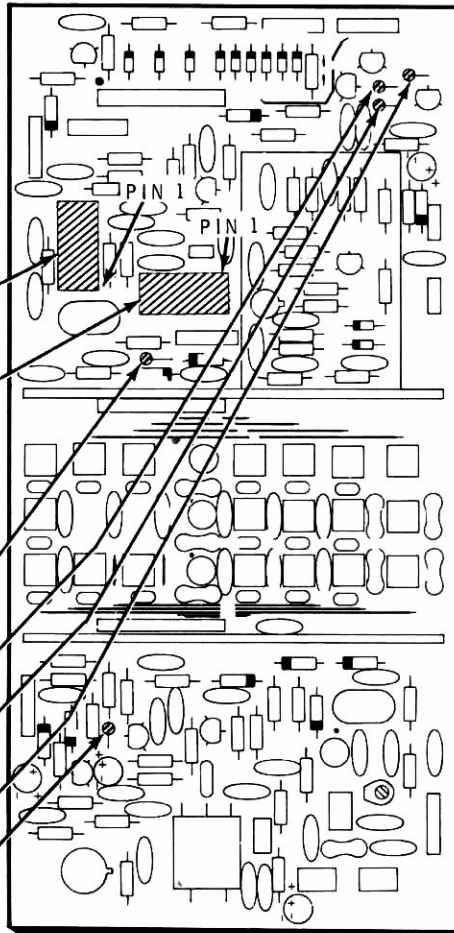

PICTORIAL 12-4

START

When you install a transistor, align its flat with the flat on the board, OR its tab with the tab on the board. Insert the leads in the correct holes in the board and position the transistor 1/4" above the board. Then solder the leads to the foil and cut off the excess lead lengths.

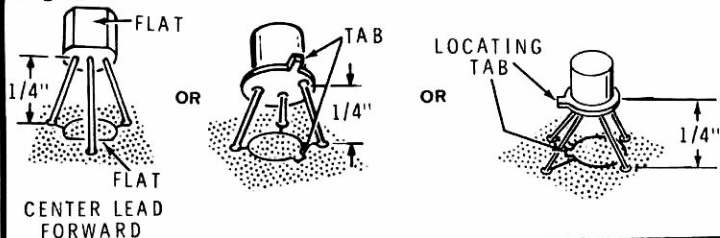

() Q409: MPSA20 transistor (#417-801).

() Q408: MPSA20 transistor (#417-801).

() Q407: MPSA55 transistor (#417-865).

() Q406: MPSA20 transistor (#417-801).

() Q405: MPSA6521 transistor (#417-172).

() Q411: MPSA6520 transistor (#417-134).

() Q404: MFE131 transistor (#417-863).

() Q402: MPS6521 transistor (#417-172).

() Q401: MPS6521 transistor (#417-172).

() Q412: MPSA55 transistor (#417-865).

() Q403: 2N3866 transistor (#417-205). Mount this transistor down against the circuit board.

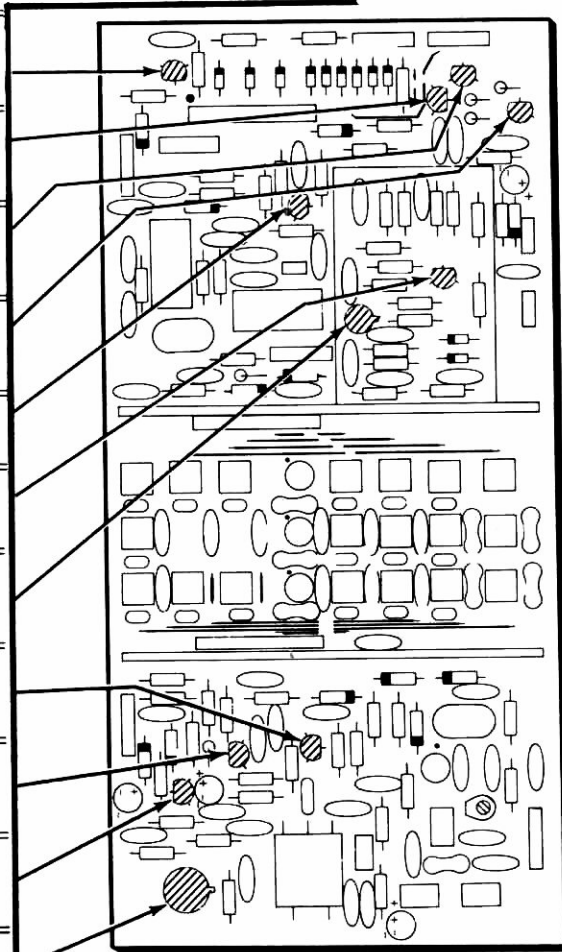

PICTORIAL 12-5

The steps performed in this Pictorial are in this area of the circuit board.

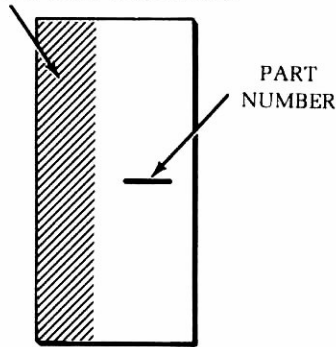

IDENTIFICATION DRAWING

CONTINUE ↘

START ↙

- C479: .05 μ F ceramic.
- C473: .001 μ F (1000pF) ceramic.
- C493: .05 μ F ceramic.
- C477: .01 μ F ceramic.
- C475: 470 pF ceramic.
- C472: .01 μ F ceramic.
- C478: .01 μ F ceramic.
- Solder the leads to the foil and cut off the excess lead lengths.
- C436: 180 pF (181) ceramic.
- C483: 9 pF ceramic.
- C484: 180 pF (181) ceramic.
- C435: 9 pF ceramic.
- C434: 180 pF (181) ceramic.
- C492: .05 μ F ceramic.
- C423: .05 μ F ceramic.
- Solder the leads to the foil and cut off the excess lead lengths.

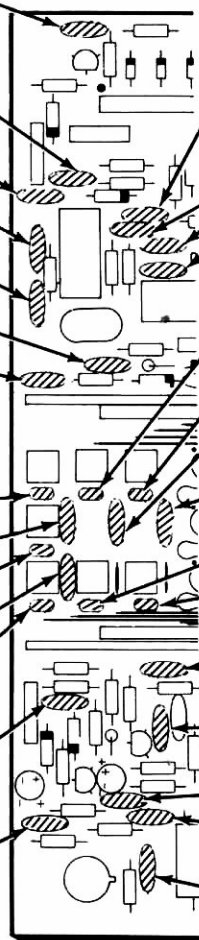

- C476: .01 μ F ceramic.
- C494: .01 μ F ceramic.
- C474: .001 μ F (1000pF) ceramic.
- C471: .01 μ F ceramic. NOTE: Your circuit board may be marked .001.
- C443: 150 pF (151) ceramic.
- C452: 180 pF (181) ceramic.
- C492: 5 pF ceramic.
- Solder the leads to the foil and cut off the excess lead lengths.
- C442: 3.3 pF ceramic.
- C441: 150 pF (151) ceramic.
- C449: 180 pF (181) ceramic.
- C425: .01 μ F ceramic.
- C409: .05 μ F ceramic.
- C413: .01 μ F ceramic.
- C417: .01 μ F ceramic.
- C416: .01 μ F ceramic.
- Solder the leads to the foil and cut off the excess lead lengths.

PICTORIAL 12-6

The steps performed in this Pictorial are in this area of the circuit board.

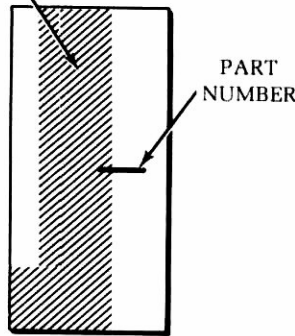

IDENTIFICATION DRAWING

START ↙

- C468: .05 μ F ceramic.
- C469: .01 μ F ceramic.
- C458: .01 μ F ceramic.
- C457: 47 pF mica.
- C456: 3.3 pF ceramic.
- C455: 47 pF mica.
- Solder the leads to the foil and cut off the excess lead lengths.
- C454: 3.3 pF ceramic.
- C453: 47 pF mica.
- C412: .01 μ F ceramic.
- C466: .05 μ F ceramic.
- C415: .1 μ F (104M) ceramic.

NOTE: When you install electrolytic capacitors, be sure to match the plus (+) mark on the capacitor with the plus (+) mark on the circuit board, or match the minus (-) mark on the capacitor with the minus mark on the circuit board.



- C418: 4.7 μ F electrolytic. NOTE: Your circuit board may be marked 10.
- C424: 10 μ F electrolytic.
- Solder the leads to the foil and cut off the excess lead lengths.

CONTINUE ↘

- C467: 20 pF ceramic.
- C465: 10 pF ceramic.
- C462: .01 μ F ceramic.
- C463: .01 μ F ceramic.
- C459: .01 μ F ceramic.
- C488: .01 μ F ceramic.
- C448: 110 pF ceramic.
- C447: 3.9 pF ceramic.
- Solder the leads to the foil and cut off the excess lead lengths.
- C446: 110 pF ceramic.
- C445: 3.9 pF ceramic.
- C444: 110 pF ceramic.
- C411: .05 μ F ceramic.
- C414: .01 μ F ceramic.
- C422: .001 μ F (1000pF) ceramic.
- C419: .01 μ F ceramic.
- C421: 10 μ F electrolytic.

Solder the leads to the foil and cut off the excess lead lengths.

PICTORIAL 12-7

The steps performed in this Pictorial are in this area of the circuit board.

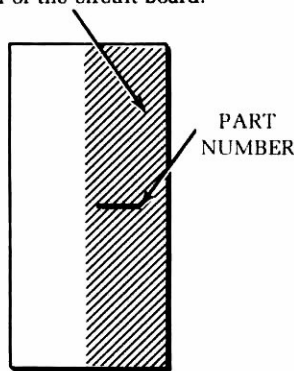

IDENTIFICATION DRAWING

START ↘

- C491: .01 μ F ceramic.
- C461: .05 μ F ceramic.
- C439: 150 pF (151) ceramic.
- C438: 6 pF ceramic.
- C486: 150 pF (151) ceramic.
- C485: 6 pF ceramic.
- Solder the leads to the foil and cut off the excess lead lengths
- C437: 150 pF (151) ceramic.
- C426: .01 μ F ceramic.
- C408: .01 μ F ceramic.
- C407: .001 μ F (1000pF) ceramic.
- C404: .0013 μ F (1300pF) ceramic.
- C403: 680 pF ceramic.
- Solder the leads to the foil and cut off the excess lead lengths

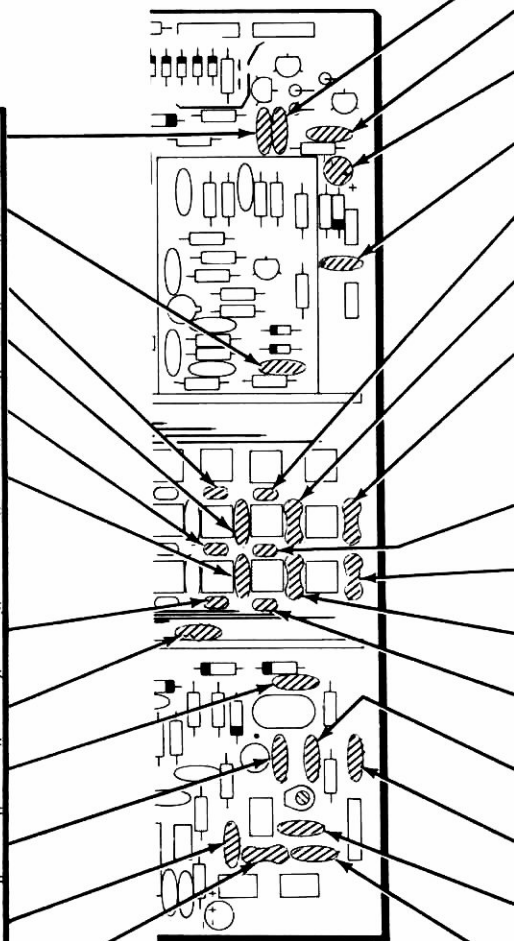

PICTORIAL 12-8

CONTINUE ↙

- C466: .01 μ F ceramic.
- C487: .05 μ F ceramic.
- C489: .33 μ F electrolytic.
- C464: .05 μ F ceramic.
- C433: 180 pF (181) ceramic.
- C432: 12 pF ceramic.
- C482: 24 pF ceramic.
- Solder the leads to the foil and cut off the excess lead lengths.
- C431: 180 pF (181) ceramic.
- C427: 24 pF ceramic.
- C429: 12 pF ceramic.
- C428: 180 pF (181) ceramic.
- C401: .01 μ F ceramic.
- C481: .05 μ F ceramic.
- C405: 33 pF ceramic.
- C402: .0013 μ F (1300pF) ceramic.
- Solder the leads to the foil and cut off the excess lead lengths.

START

Reposition the circuit board as shown in the Identification Drawing.

When you install a coil, insert its pins as far as possible into their holes. Solder the pins to the foil as you install each coil.

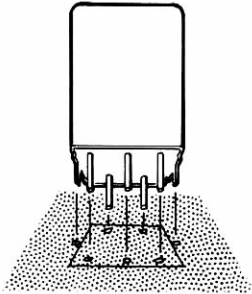

- () L414: 13 μ H coil (#40-2069).
- () L417: 3 μ H coil (#40-2070).
- () L424: .9 μ H coil (#40-2072).
- () L431: .71 μ H coil (#40-2073).
- () L434: .57 μ H coil (#40-2074).
- () L427: .3 μ H coil (#40-2076).
- () L421: 1.5 μ H coil (#40-2071).
- () L419: 1.5 μ H coil (#40-2071).

IDENTIFICATION DRAWING

PART NUMBER

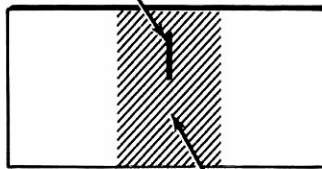

The steps performed in this Pictorial are in this area of the circuit board.

CONTINUE

- () L413: 13 μ H coil (#40-2069).
- () L412: 13 μ H coil (#40-2069).
- () L416: 3 μ H coil (#40-2070).
- () L415: 3 μ H coil (#40-2070).
- () L423: .9 μ H coil (#40-2072).
- () L422: .9 μ H coil (#40-2072).
- () L428: .71 μ H coil (#40-2073).
- () L429: .71 μ H coil (#40-2073).
- () L432: .57 μ H coil (#40-2074).
- () L425: .3 μ H coil (#40-2076).
- () L418: 1.5 μ H coil (#40-2071).

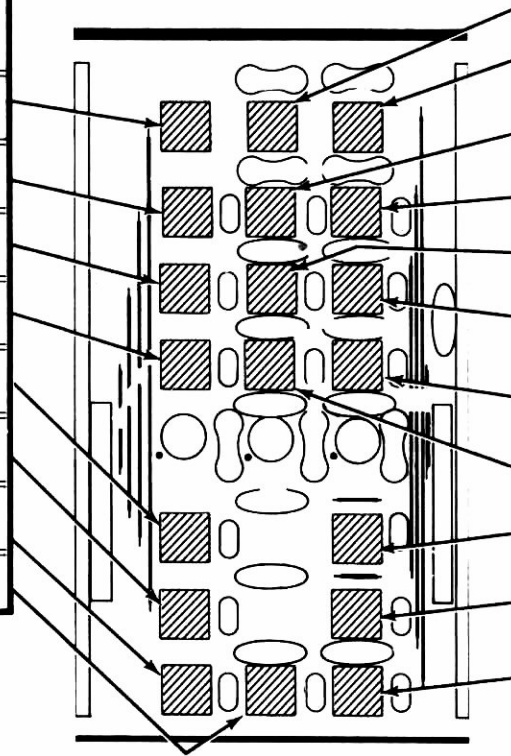

PICTORIAL 12-9

START ↘

Solder the pins or leads when you install each part on this Pictorial. Then cut off any excess lead lengths.

When you install a plug, push its shorter pins into the holes in the circuit board.

() 5-pin plug at P409.

() 5-pin plug at P410.

() 5-pin plug at P408.

() 5-pin plug at P411.

() 2-pin plug at P406. Cut one pin off of a 3-pin plug.

() 5-pin plug at P407.

() 3-pin plug at P405.

() 3-pin plug at P404.

() 5-pin plug at P401.

() 3-pin plug at P402.

() 5-pin plug at P403.

() L404: 7 μ H toroid coil (#40-1726).

() L403: 1.8 μ H toroid coil (#40-1792).

() L402: 1.8 μ H toroid coil (#40-1792).

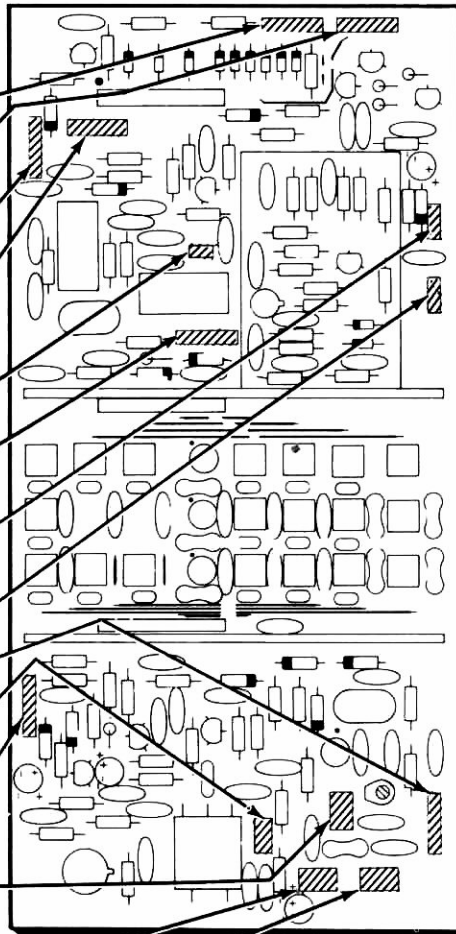

PICTORIAL 12-10

CONTINUE ↘**CIRCUIT BOARD CHECKOUT**

Carefully inspect the circuit board for the following conditions.

() Unsoldered connections.

() Poor solder connections.

() Solder bridges between foil patterns.

() Protruding leads which could touch together.

() Transistors and diodes for the correct position and installation.

() Electrolytic capacitors for the correct position of the positive (+) lead.

Heathkit[®]

Refer to Pictorial 12-11 (Illustration Booklet, Page 14) for the following steps.

- () Locate the following 6" 2-wire cables set aside earlier. DO NOT separate the ends of these cables yet.

Brown and red pair

Orange and yellow pair

- () Refer to Detail 12-11A (Illustration Booklet, Page 14) Part A and pass one end of the brown and red pair through one of the holes in a ferrite core. Allow this pair to extend 1" from the left (Start) end of the core as shown.
- () Refer to Parts A and B of the Detail and wrap this pair 2-1/2 turns through the hole and around the outside of the core. Follow the 1-through-6 numbered sequence shown on the Detail. Keep the red wire on top (do not allow the wires to twist) and press each successive wrap tight against the inside of the hole and the outside of the ferrite core. NOTE: When you pull the last wrap tight, the wires should extend 5/8" or more from the right (Finish) end of the core. If not, retighten each wrap until you get the 5/8" extension of the pair.
- () Similarly, wrap the orange and yellow pair through the other hole in the ferrite core. This time, keep the yellow wire on top.
- () Refer to Part B of the Detail and separate the wires at the end of each pair all-the-way to the holes in the ferrite core.
- () Refer to Part C of the Detail and cut each wire to the indicated length at the Start and Finish end of the ferrite core. Then remove 1/4" of insulation from the end of each wire.
- () Refer to Part D of the Detail, and at the Start end, tightly twist together the bared ends of the brown and orange wires.
- () Similarly, at the Finish end, twist together the brown and yellow wire ends and the red and orange wire ends.

- () Twist the bared end of the red wire and the yellow wire (not together), and then melt a very small amount of solder on the very ends of the bared wires. Use only enough solder to hold the fine wire strands together. Too much solder will not allow you to fit the wires into the circuit board holes later.
- () Refer again to Part D of the Detail and position the wire ends coming from the prepared coil so they are properly aligned with their correct holes in the circuit board. Then insert all of the wires into their holes and solder them to the foil. Cut off any excess wire ends.
- () Cut a 3" length of desoldering braid. Flatten this desoldering braid to be sure there are no twists in it.
- () Cut a 10" length of the small violet stranded wire that was supplied with the RF circuit board parts. Then remove 1/8" of insulation from **one end**, twist together the fine strands, and melt a small amount of solder on the exposed end. Save the remaining violet wire.
- (*) Refer to Detail 12-11B (Illustration Booklet, Page 15) Part A, solder the end of the violet wire to the side of, and 1" from one end of the desoldering braid. Then bend the desoldering braid in half as shown.
- () Refer to Part B of the Detail and insert the ends of the desoldering braid through the holes in a ferrite core. The solder connection for the violet wire should be at the left end of the indicated hole in the ferrite core.
- () Push a round rod (drill bit, etc.) of the largest possible diameter (about 1/8") all-the-way into (but not clear through) both holes in the ferrite core to compress the desoldering braid flat against the sides of the web (center) of the ferrite core. Then remove the rod.

NOTE: As you proceed with the winding of this transformer, **continuously push each wire against the web of the ferrite core**. If you do not do this, you will not be able to complete all 6 wraps. Use progressively smaller rods. You can use the large bare wire supplied with the kit to push the last two turns against the ferrite core.

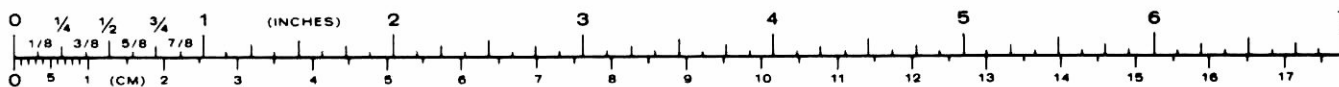

- () Refer to Part B of the Detail and proceed with the winding of the transformer. Wrap the violet wire around the web (through both holes) of the ferrite core.
- () Refer to Part C of the Detail and finish wrapping the 6 wraps of violet wire (5 wires at the bottom and 6 wires at the top) on the ferrite core. When you complete the 6 wraps, there should not be enough violet wire left to make another complete wrap.
- () Refer to Part C of the Detail and remove all but 1/8" of insulation from the end of the violet wire at the bottom of the ferrite core. Then melt a small amount of solder on the ends of the desoldering braid and the bared violet wire. Set the completed transformer aside temporarily.
- () Use the same procedure to make another transformer identical to the one you just completed.
- () T401: Refer to Part D of the Detail 12-11B and install one of the just-completed transformers at location T401 on the RF circuit board. Be sure you insert the desoldering braid with the violet wire soldered to it into the single hole end of the outline on the circuit board. Solder the leads to the foil and cut off any excess lead lengths. NOTE: Do not use excessive heat when you solder the braid to the circuit board. To do so could melt the insulation on the violet wire.
- () T403: Refer to Part E of the Detail and similarly install the other transformer at location T403 on the circuit board.
- () L437: Refer to Detail 12-11C and install a .35 μ H variable inductor (#40-2078, black body) at location L437 on the circuit board. Align the notch on the inductor body with the dot on the circuit board. Solder the leads to the foil and cut of any excess lead lengths.
- () L436: Similarly, install a .53 μ H variable inductor (#40-2077, yellow body) at location L436 on the circuit board. Be sure to align the notch on the inductor body with the dot on the circuit board.

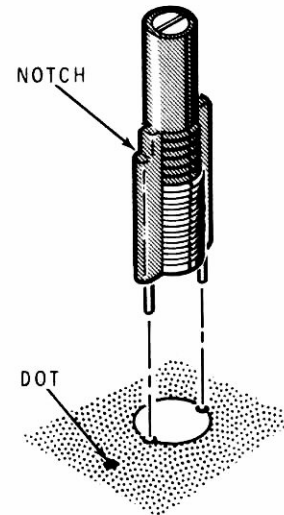

Detail 12-11C

- () L435: Similarly, install a .35 μ H variable inductor (#40-2078, black body) at location L435 on the circuit board. Be sure to align the notch on the inductor body with the dot on the circuit board.
- () L405: Similarly, install a .35 μ H variable inductor (#40-2078, black body) at location L405 on the circuit board. Be sure to align the notch on the inductor body with the dot on the circuit board.
- () Refer to Detail 12-11D and push the round transistor heat sink onto transistor Q403.

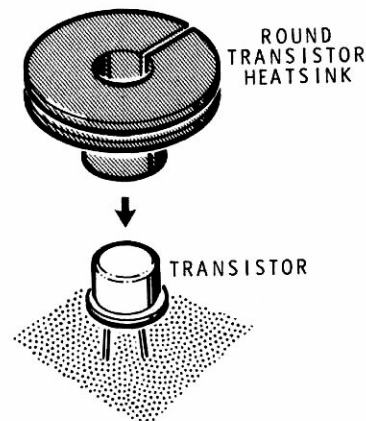

Detail 12-11D

- () SW401C: Refer to Detail 12-11E and install a rotary switch at location SW401C on the circuit board. **Position the switch so the side with the color dot is toward the dot mark on the circuit board outline.** Be sure all of the pins are in their circuit board holes and the switch is tight against the circuit board. Then solder one of the center pins to the foil. Again, make sure the switch is tight against and perpendicular to the circuit board; then solder the remaining pins to the foil.
- () Refer to Detail 12-11F (Illustration Booklet, Page 15) and the Pictorial and install both shield plates at their locations on the circuit board. Position the shield plates so their slots are oriented as shown. Be sure the plates are perpendicular to the circuit board; then solder only the center tab to the foil. The other tabs will be soldered later.
- () Twist the tabs on the small shield 90°. Then insert the tabs of the small shield into their circuit board holes and solder the flange of the small shield to the front shield plate. Be sure the small shield and shield plate are tight against each other and the circuit board. Then solder the tabs of the small shield to the foil.
- () SW401B: Position a rotary switch so its color dot side faces the other previously-installed rotary switch and insert the pins of the switch into their holes in the circuit board at location SW401. Then secure the switch to the shield plate with 4-40 black phillips head hardware. Do not solder the switch pins to the foil yet.
- () SW401A: Similarly, install a rotary switch at location SW401A in the circuit board.
- () Align the notches in the shield plate cover with the rotary switch mounting screws and fit the cover down onto the shield plates. The flanges on the cover must fit on the outside of the shield plates. Now secure the cover to the shield plates with #6 × 1/4" hex head sheet metal screws in the indicated holes.
- () Push the shield plates tight against the circuit board and solder the end tabs of the plates to the foil.
- () Solder the pins of rotary switches SW401B and SW401A to the foil.

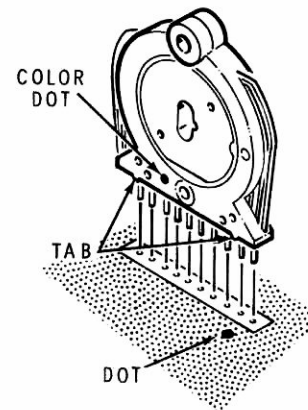

Detail 12-11E

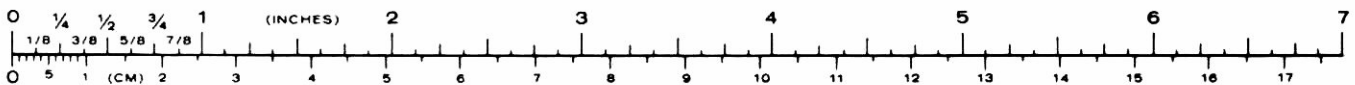

INITIAL TESTS

NOTE: In the following steps, the setting of your ohmmeter is indicated in parentheses, "(R × 10K)" for example, because meaningful readings cannot be taken using a single range. Be sure to zero your ohmmeter each time you change its range.

Refer to Pictorial 12-12 (Illustration Booklet, Page 16) for the following steps.

- () Connect the common ohmmeter lead to a ground point on the RF circuit board. NOTE: A convenient point is a foil pad at one of the corner circuit board mounting holes.

Use the positive ohmmeter probe to check the RF circuit board plugs and pins for the following readings. Note that, as on the previous circuit boards, the steps are abbreviated.

NOTE: Do not change ohmmeter ranges unless a step directs you to do so.

- () P401-1 & 2. 80 kΩ or greater. Check C401, C481. (R × 10K).
- () P401-5. Infinity. Check C402.
- () P402-1. Infinity. Check C414.
- () P402-3. 10 kΩ to 20 kΩ. Check C419, C421, C422. (R × 1000).
- () P403-1, 2, & 3. 7000 Ω to 15 kΩ. Check C492, C425.
- () P403-4. Infinity. Check D405.
- () P403-5. 2000 Ω to 3000 Ω. Check Q412, C418.
- () P404-1. 5000 Ω to 10 kΩ. Check C464, D411.
- () P404-2. 10 kΩ to 20 kΩ. Check C451, L439.
- () P404-3. 5000 Ω to 10 kΩ. Check D409.
- () P405-1. Approximately 600 Ω. Check C487, L443. (R × 100).
- () P405-2. Infinity. Check circuit board foils. (R × 10K).
- () P405-3. Approximately 100 kΩ. Check D410.
- () P406-1. Infinity. Check C471, C474.
- () P407-1 & 2. Infinity. Check C494.
- () P407-3. Infinity. Check C476.
- () P407-5. Approximately 20Ω. Check U401. (R × 10).
- () P408-1. Infinity. Check D427. (R × 10K).
- () P408-2. Infinity. Check Q409, C479.
- () P408-4. Infinity. Check C475, C477.
- () P408-5. Approximately 40 kΩ. Check C478, C493, L446.
- () P409-1. 100 kΩ. Check D424, C425, D426.
- () P409-2. Infinity. Check D413.
- () P409-3. 100 kΩ. Check D422, D423.
- () P409-4. Approximately 150 kΩ. Check D426.
- () P409-5. Infinity. Check Q408.
- () P410-1, 2, & 3. 200 kΩ to 300 kΩ. Check Q407.
- () P410-4. Approximately 100 kΩ. Check Q406.
- () P411-1. 200 kΩ to 300 kΩ. Check D414.
- () P411-2. Infinity. Check SW401C.
- () P411-3. 100 kΩ to 200 kΩ. Check D422.
- () P411-4. 100 kΩ to 200 kΩ. Check D423.
- () P411-5. 100 kΩ to 200 kΩ. Check D418, D424.

This completes the "Initial Tests" of your RF circuit board. Set the circuit board aside until it is called for during the assembly of the chassis. Proceed to "ALC Circuit Board".

ALC CIRCUIT BOARD

PARTS LIST

() Refer to the Pack Index Sheet and locate Pack #13. Then remove the parts from this pack and check each part against the following list. The key numbers correspond to the numbers on the "ALC Circuit Board Parts Pictorial" (Illustration Booklet, Page 16). Return any part that is packed in an individual envelope, with the part number on it, back into its envelope until that part is called for in a step. Do not throw away

any packing material until you account for all the parts.

To order a replacement part, always include the PART NUMBER. Use the Parts Order Form furnished with this kit. If a Parts Order Form is not available, refer to "Replacement Parts" inside the rear cover of this Manual. For prices, refer to the separate "Heath Parts Price List."

KEY No.	HEATH Part No.	QTY.	DESCRIPTION	CIRCUIT Comp. No.
---------	----------------	------	-------------	-------------------

RESISTORS

NOTES:

- Resistors may be packed in more than one envelope. Open all of the resistor envelopes in this pack before you check the resistors against the following Parts List.
- The following resistors are rated at 1/4-watt and have a tolerance of 5% (fourth band gold) unless otherwise noted. 1% resistors have a brown fifth color band.

A1	6-470-12 *	2	47 Ω (yel-viol-blk)	R651, R652
A1	6-201-12	1	200 Ω (red-blk-brn)	R664
A1	6-1101-12	1	1100 Ω, 1% (brn-brn-blk-brn)	R661
A1	6-332-12	1	3300 Ω (org-org-red)	R653
A1	6-392-12	1	3900 Ω (org-wht-red)	R654
A1	6-103-12	5	10 kΩ (brn-blk-org)	R655, R656, R663, R665, R666
A1	6-153-12	1	15 kΩ (brn-grn-org)	R657
A1	6-273-12	1	27 kΩ (red-viol-org)	R659
A1	6-474-12	1	470 kΩ (yel-viol-yel)	R662

CAPACITORS

B1	21-169	1	6 pF ceramic	C651
B1	21-722	1	330 pF ceramic	C652

KEY No.	HEATH Part No.	QTY.	DESCRIPTION	CIRCUIT Comp. No.
---------	----------------	------	-------------	-------------------

Capacitors (Cont'd)

B1	21-140	2	.001 μF (1000 pF) ceramic	C653, C654
B3	21-761	3	.01 μF (103) glass ceramic	C656, C657, C658
B2	25-859	1	.47 μF electrolytic	C655

INDUCTORS

C1	40-1011	1	30 μH toroid	L651
C2	45-604	1	100 μH choke (brn-blk-brn)	L652

DIODES

D1	56-20	2	1N295A (red-wht-grn)	D651, D652
D1	56-652	1	1N4448	D653
D1	56-58	1	1N5234B	D654

MISCELLANEOUS

E1	10-1140	1	500 Ω control	R658
	85-2681-3	1	ALC circuit board	
E2	253-1	1	#6 fiber flat washer	
E3	257-12	1	Eyelet	
E4	417-864	4	MPSA05 transistor	Q651, Q652, Q653, Q654
E5	432-969	1	5-pin plug	P651
E6	434-146	3	Phono socket	S652, S653, S651

STEP-BY-STEP ASSEMBLY

START ↓

- () Position the circuit board as shown.
- () C561: 6 pF ceramic.
- () C652: 330 pF ceramic.
- () R652: 47 Ω (yel-viol-blk).
- () R653: 3300 Ω (org-org-red).
- () R651: 47 Ω (yel-viol-blk).
- () C653: .001 μ F ceramic.
- () Solder the leads to the foil and cut off the excess lead lengths.
- () R654: 3900 Ω (org-wht-red).
- () R661: 1100 Ω , 1% (brn, brn-blk-brn).
- () R655: 10 k Ω (brn-blk-org).
- () C656: .01 μ F (103) glass ceramic.
- () R663: 470 k Ω (yel-viol-yel).

NOTE: DIODES MAY BE SUPPLIED IN ANY OF THE FOLLOWING SHAPES. ALWAYS POSITION THE BANDED END AS SHOWN ON THE CIRCUIT BOARD.

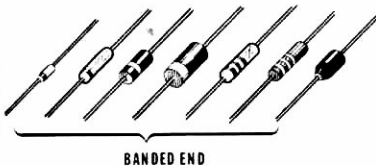

- () D653: 1N4448 (#56-652). Position the diode with the banded end up.
- () Solder the leads to the foil and cut off the excess lead lengths.

CONTINUE ↓

- () C654: .001 μ F ceramic.
- () D652: 1N295A (red-wht-grn), #56-20.
- () D651: 1N295A (red-wht-grn), #56-20.
- () R659: 27 k Ω (red-viol-org).
- () R657: 15 k Ω (brn-grn-org).
- () R664: 200 Ω (red-blk-brn).
- () Solder the leads to the foil and cut off the excess lead lengths.
- () R656: 10 k Ω (brn-blk-org).
- () C657: .01 μ F (103) glass ceramic.
- () R665: 10 k Ω (brn-blk-org).
- () R662: 10 k Ω (brn-blk-org).
- () R666: 10 k Ω (brn-blk-org).
- () C658: .01 μ F (103) glass ceramic.
- () D654: 1N5234B (#56-58). Banded end up.
- () L652: 100 μ H choke (#45-604, brn-blk-brn).
- () Solder the leads to the foil and cut off the excess lead lengths.

PICTORIAL 13-1

START

() L651: 30 μ H toroid (#40-1011). Install the coil as shown. Insert the entire bare end of the leads into the board. Solder the leads to the foil and cut off the excess lengths.

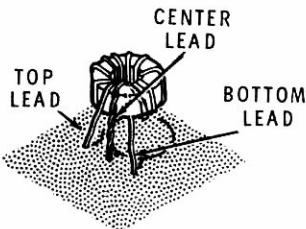

() S651: Phono socket. Solder the two tabs and center lug to the foil and cut off the excess lengths.

() R658: 500 Ω (#10-1140) control. Bend the leads down 90° as shown. Install the control, solder the leads to the foil, and cut off the excess lengths.

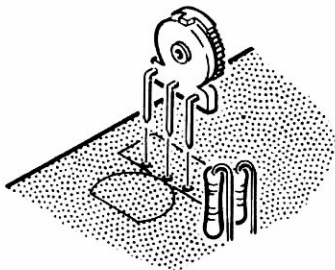

() P651: 5-pin plug. Insert the short pins into the board. Solder them to the foil and cut off the excess pins.

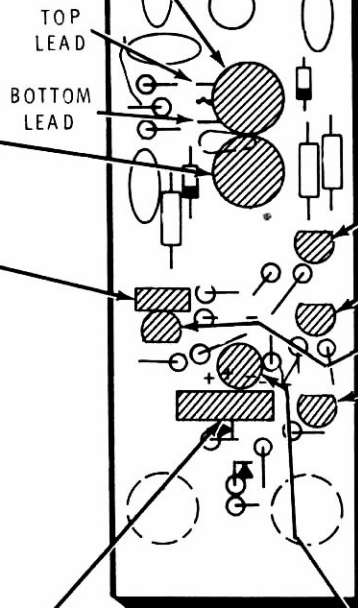

CONTINUE

() 3/4" small bare wire in hole A. Solder one end of the wire to the foil. The other end will be connected later.

NOTE: When you install each of the following transistors, position the flat on the transistor over the outline of the flat on the circuit board. Then insert the leads into the circuit board holes and solder them to the foil. Cut off the excess lead lengths.

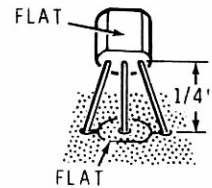

Four MPSA05 (#417-864) transistors:

() Q652.

() Q653.

() Q651.

() Q654.

NOTE: When you install electrolytics, be sure to match the positive (+) mark on the capacitor with the positive (+) mark on the circuit board, or match the negative (-) mark on the capacitor with the negative mark on the circuit board.

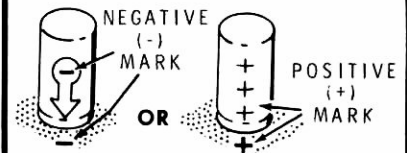

() C655: 7 μ F electrolytic. Solder the leads to the foil and cut off the excess lengths.

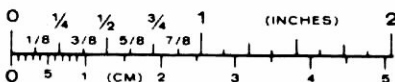

PICTORIAL 13-2

START 

() Position the circuit board with the foil side up as shown.

() Position both phono sockets as shown. Then bend the center lug at a 90° angle at the dimension shown. Cut it off 1/16" from the end.

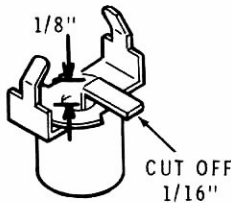

() S652: Position the phono socket with the center lug as shown and install it on the board. Solder both tabs and the center lug to the foil.

() S653: Similarly install the other phono socket. Note the position of the center lug.

() Place the #6 fiber flat washer over the eyelet and insert the eyelet through coil L651 from the component side of the board as shown in Detail 13-3A. Solder the eyelet to the foil.

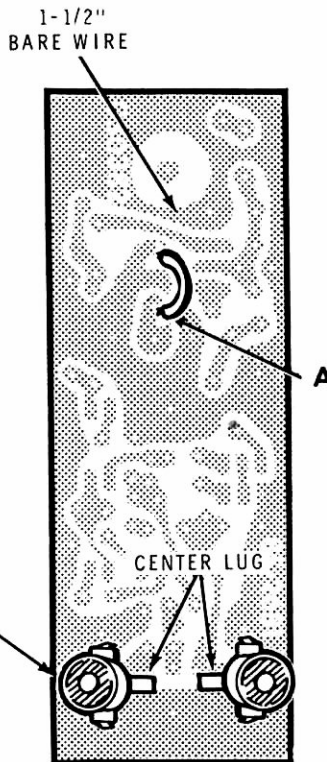

PICTORIAL 13-3

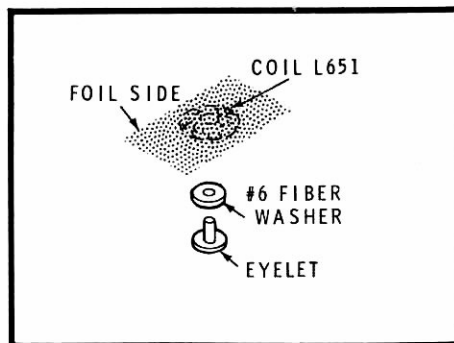

CONTINUE 

() Cut a 1-1/8" length of teflon sleeving and a 1-5/8" large bare wire.

() Use the following procedure to install the 1-5/8" large bare wire in the circuit board at hole A:

1. Slide the 1-1/8" length of Teflon sleeving over the large bare wire. Then form the wire as shown below.
2. Push one end of the wire and sleeving into the eyelet in the circuit board (from the foil side).
3. Insert the other end of the wire in hole A. Make sure it does not touch the case of the phono socket on the component side of the board. Then solder the wire to the foil.

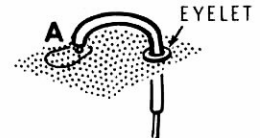

NOTE: The end of the wire that extends through the eyelet will be connected later.

CIRCUIT BOARD CHECKOUT

Carefully inspect the circuit board for the following conditions.

- () Unsoldered connections.
- () Poor solder connections.
- () Solder bridges between foil patterns.
- () Protruding leads which could touch together.
- () Transistors for the proper installation.
- () Diodes for the proper installation.
- () Electrolytic capacitor for the correct position of the positive (+) lead.

FINISH

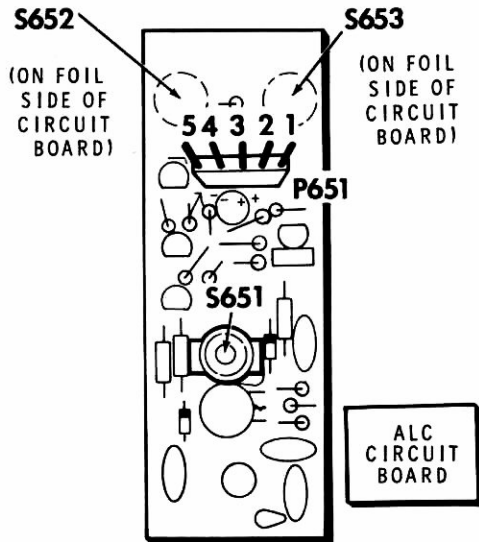

PICTORIAL 13-4

INITIAL TESTS

Refer to Pictorial 13-4 for the following steps.

- () Connect the common ohmmeter test lead to a ground point on the ALC circuit board. NOTE: A convenient point is the outer shell of the phono socket that is mounted on top of the circuit board.

Use the positive ohmmeter probe to check the ALC circuit board plug and phono sockets for the following readings. Note that, as on the previous circuit boards, the steps are abbreviated.

- () Set the ohmmeter to $R \times 10K$. Use this ohmmeter range for all of the following checks.
- () Check the inner contact of phono socket S651. Infinity. Check for a solder bridge on the circuit board.
- () Check the inner contact of phono socket S652. Infinity. Check D654, C658.
- () Check the inner contact of phono socket S653. Infinity. Check for a solder bridge on the circuit board.
- () P651-2. Infinity. Check C655, C656.
- () P651-3. Infinity. Check D653.
- () P651-4. Approximately $70\text{ k}\Omega$. Check Q653, Q654.
- () P651-5. Approximately $70\text{ k}\Omega$. Check Q653, Q654.

This completes the "Initial Tests" of your ALC circuit board. Set the circuit board aside until it is called for during the assembly of the power amplifier. Proceed to "Power Amplifier Assembly".

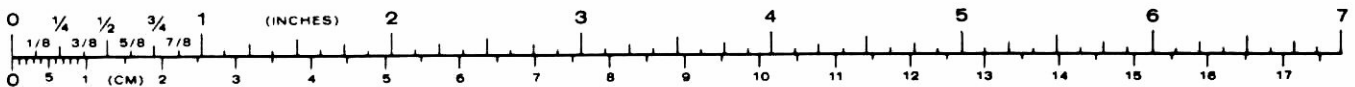

PA (POWER AMPLIFIER) ASSEMBLY

PARTS LIST

- () Refer to the Pack Index Sheet and locate Pack #14. Then remove the parts from this pack and check each part against the following list. The key numbers correspond to the numbers on the "PA Circuit Board Parts Pictorial" (Illustration Booklet, Page 17). Return any part that is packed in an individual envelope, with the part number on it, back into its envelope until that part is called for in a step. Do not throw away

any packing material until you account for all the parts.

To order a replacement part, always include the PART NUMBER. Use the Parts Order Form furnished with this kit. If a Parts Order Form is not available, refer to "Replacement Parts" inside the rear cover of this Manual. For prices, refer to the separate "Heath Parts Price List."

KEY No.	HEATH Part No.	QTY.	DESCRIPTION	CIRCUIT Comp. No.
---------	----------------	------	-------------	-------------------

RESISTORS

NOTES:

- Resistors may be packed in more than one envelope. Open all of the resistor envelopes in this pack before you check the resistors against the following Parts List.
- The following resistors are rated at 1/4-watt and have a tolerance of 5% (fourth band gold) unless otherwise noted. 10% is indicated by a silver fourth band.

A1	6-229	4	2.2 Ω, 1/2-watt (red-red-gold)	R1221, R1222, R1223, R1224
A1	6-689-12	2	6.8 Ω (blu-gry-gold)	R1208, R1209
A1	6-100-12	4	10 Ω (brn-blk-blk)	R1201, R1202, R1217, R1218
A1	6-150-12	2	15 Ω (brn-grn-blk)	R1211, R1212
A1	6-220-12	1	22 Ω (red-red-blk)	R1206
A1	6-270-12	2	27 Ω (red-viol-blk)	R1203, R1204
A1	6-470-12	1	47 Ω (yel-viol-blk)	R1213
A3	1-20-2	2	100 Ω, 2-watt, 10% (brn-blk-brn)	R1216, R1219
A4	3-37-5	1	120 Ω, 5-watt wirewound	R1207
A3	6-151-2	1	150 Ω, 2-watt (brn-grn-brn)	R1205
A1	6-471-12	1	470 Ω (yel-viol-brn)	R1214

KEY No.	HEATH Part No.	QTY.	DESCRIPTION	CIRCUIT Comp. No.
---------	----------------	------	-------------	-------------------

CAPACITORS

Mica

B1	20-159	1	39 pF	C1202
B1	20-78	1	56 pF	C1205
B2	20-725	2	250 pF	C1215, C1216
B1	20-116	1	400 pF	C1219
B1	20-113	1	470 pF	C1218
B1	20-172	3	1000 pF	C1207, C1208, C1211

Ceramic

B3	21-53	4	.001 μF (1000 pF) feedthrough	C1225, C1226, C1227, C1228
B4	21-140	1	.001 μF	C1222
B4	21-27	2	.005 μF (5000 pF)	C1229, C1231
B4	21-176	9	.01 μF	C1201, C1203, C1204, C1206, C1209, C1213, C1214, C1217, C1225
B4	21-143	1	.05 μF	C1212

Other Capacitors

B5	25-885	1	100 μF electrolytic	C1232
B5	25-887	1	220 μF electrolytic	C1224
B6	25-877	1	2200 μF electrolytic	C1233

Heathkit®

KEY No.	HEATH Part No.	QTY.	DESCRIPTION	CIRCUIT Comp. No.	KEY No.	HEATH Part No.	QTY.	DESCRIPTION	CIRCUIT Comp. No.
---------	----------------	------	-------------	-------------------	---------	----------------	------	-------------	-------------------

Other Capacitors (Cont'd)

B7	27-188	2	.1 μ F Mylar	C1221, C1223
----	--------	---	------------------	--------------

DIODES

C1	57-27	2	1N2071	D1201, D1202
C1	56-652	2	1N4448	D1203, D1204

TRANSISTORS

NOTE: Transistors may be marked for identification in any of the following four ways:

1. Part number.
2. Type number.
3. Part number and type number.
4. Part number with a type number other than the one listed.

D1	417-818	1	MJE181	Q1205
D2	417-971	2	Predriver	Q1201, Q1202
D2	417-972	2	Driver	Q1203, Q1204
D3	117-16	1	Matched set of two Final transistors	Q1206, Q1207

HARDWARE

#4 Hardware

E1	250-1411	1	4-40 \times 1/4" black phillips head screw
E2	250-577	6	4-40 \times 1/4" black allen head screw
E3	250-213	2	4-40 \times 5/16" screw
E4	252-2	2	4-40 nut
E5	254-9	2	#4 lockwasher

#6 Hardware

F1	250-1325	8	6-32 \times 1/4" black phillips head screw
F2	250-1331	1	6-32 \times 5/8" black phillips head screw
F3	250-1158	6	6-32 \times 3/4" threaded stud
F4	252-3	11	6-32 nut
F5	254-1	15	#6 lockwasher
F6	259-1	2	#6 solder lug

#8 Hardware

G1	250-1477	1	8-32 \times 1-1/4" screw
G2	252-4	3	8-32 nut
G3	252-180	1	8-32 wingnut
G4	253-45	2	#8 flat washer
G5	254-2	2	#8 lockwasher

Other Hardware

H1	255-13	1	1/4" \times 1/4" long spacer
H2	255-21	4	1/4" \times 7/8" tapped spacer

MISCELLANEOUS

J1	10-295	1	750 Ω control	R1215
J2	45-612	4	10 μ H RF choke (brn-blk-blk)	L1201, L1202, L1203, L1204
J3	60-4	1	Slide switch	
J4	75-108	1	1-3/4" \times 2" insulator paper	
J5	75-704	1	Transistor insulator (packed between two pieces of cardboard)	
J6	85-2785-1	1	PA circuit board	
J6	85-2690	3	L IN circuit board	
J7	85-2691	3	L OUT circuit board	
J8	85-2692	1	H IN circuit board	
J9	85-2693	1	H OUT circuit board	
J10	206-1410	1	Shield	
J11	215-94	2	Transistor heat sink	
J12	266-1126	2	Long brass tube	
J13	266-1206	6	Short brass tube	
J14	434-42	1	Phono socket (chassis mount)	
J15	434-146	2	Phono socket (circuit board mount)	S1201, S1202
J16	436-51	1	Coaxial socket	
J17	475-10	2	7/32" long ferrite bead	
J18	475-12	1	5/16" long ferrite bead	
J19	475-15	13	1/8" long ferrite bead	
J20	475-17	12	3/16" long ferrite bead	
J21	475-27	4	1/4" long ferrite bead (red)	
J21	475-28	6	1/4" long ferrite bead (green)	

FROM THE FINAL PACK (parts left in the shipping carton)

K1	203-2109-1	1	Rear panel
K2	215-665	1	Large heat sink

STEP-BY-STEP ASSEMBLY

START 

Position the power amplifier circuit board lettered side (not the foil side) up as shown in the Pictorial. DO NOT solder to the foil on the lettered side of the board unless you are instructed to do so in a step.

NOTE: All of the resistors installed in this Pictorial are 1/4-watt.

- () R1203: 27 Ω (red-viol-blk).
- () R1201: 10 Ω (brn-blk-blk).
- () R1202: 10 Ω (brn-blk-blk).
- () R1204: 27 Ω (red-viol-blk).
- () D1201: 1N2071 diode (#57-27). See Detail 14-1A.
- () R1208: 6.8 Ω (blu-gry-gold).
- () R1211: 15 Ω (brn-grn-blk).
- () R1209: 6.8 Ω (blu-gry-gold).
- () R1212: 15 Ω (brn-grn-blk).
- () R1217: 10 Ω (brn-blk-blk).
- () R1214: 470 Ω (yel-viol-brn).
- () R1218: 10 Ω (brn-blk-blk).
- () Solder the leads to the foil and cut off the excess lead lengths.

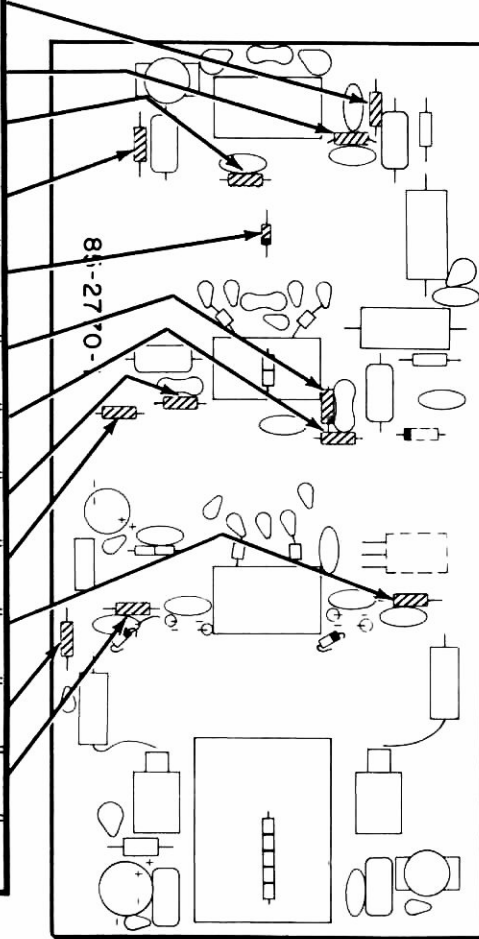

NOTE: DIODES MAY BE SUPPLIED IN ANY OF THE FOLLOWING SHAPES. ALWAYS POSITION THE BANDED END AS SHOWN ON THE CIRCUIT BOARD.

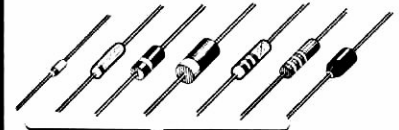

BANDED END
Detail 14-1A

PICTORIAL 14-1

START

When you install a ferrite bead (or ferrite beads) in the next **four** steps, place the beads(s) on a 1" small bare wire. Bend the bare wire to fit into the holes in the circuit board. Then solder the wire to the foil and cut off the excess wire lengths.

() 7/32" long ferrite bead.

() 7/32" long ferrite bead.

() Two 1/8" long ferrite beads.

() Two 1/8" long ferrite beads.

When you install the capacitors in the next two steps, position its flat side up. Bend the tab so it is even with the bottom, and solder both sides to the foil on the printed side of the circuit board. **DO NOT** solder the tab to its foil at this time.

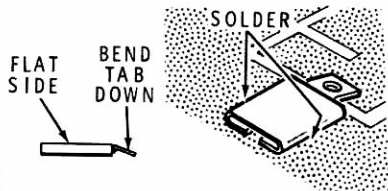

() C1215: 250 pF mica.

() C1216: 250 pF mica.

When you perform the next two steps, use the specified length of large bare wire.

() Five 1/8" long ferrite beads on a 1-1/4" large bare wire. Be careful not to break the ferrite beads when you bend the wire to fit the circuit board.

() 5/16" long ferrite bead on a 1-1/2" large bare wire.

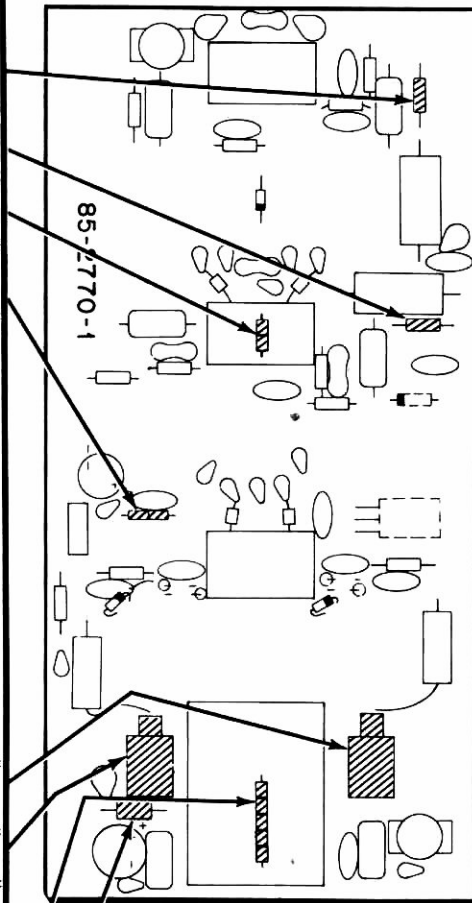

PICTORIAL 14-2

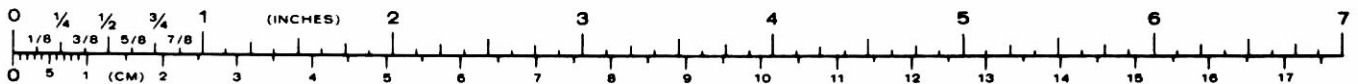

Refer to Pictorial 14-3 (Illustration Booklet, Page 18) for the following steps.

- () Refer to Detail 14-3A (Illustration Booklet, Page 19) Part A and assemble a small transformer form with an "L IN" circuit board (#85-2690), an "L OUT" circuit board (#85-2691), four 3/16" long ferrite beads, and two short brass tubes. Be sure the circuit board part numbers are both up and at the outside ends of the assembly.

NOTE: In some of the following steps, you will solder brass tubes to circuit boards. To make the tubes easier to solder, use steel wool or fine sand paper on the ends of the tubes until they are bright.

- () Refer to Part B of the Detail and push the circuit boards tightly against the ferrite beads and adjust the brass tubes so they protrude the same amount from each circuit board. Check to see that the bottom edges of both circuit boards are parallel to each other, and set the assembly on a 3" small bare wire that is formed into a "U" shape. The bare wire will help to stabilize the assembly and keep the brass tube from being pushed all the way to one end. Now solder the brass tubes to the foil on the #85-2690 circuit board.
- () When the assembly is cool enough to handle, turn it over onto the bare wire as shown in Part C of the Detail, and solder the brass tubes to the foils on the #85-2691 circuit board.
- () Similarly, assemble two more transformer forms identical to the one you just completed.

- () Refer to Detail 14-3B and assemble a large transformer form with an "H IN" circuit board (#85-2692), an "H OUT" circuit board (#85-2693), four 1/4" long red ferrite beads, six 1/4" long green ferrite beads, and two long brass tubes. Be sure that you have positioned the part numbers on both circuit boards up and to the outside ends of the assembly. **Also, be sure you have alternated the red and green ferrite beads.**

- () Now solder the brass tubes to the circuit board foil(s) as you did with the small transformer forms.

Refer to Pictorial 14-3 for the following steps.

- () T1201: Refer to inset drawing #1 on Pictorial 14-3 and install one of the small transformer forms at location T1201 on the power amplifier circuit board. Be sure the #85-2690 circuit board is next to circuit board holes AA and BB. Position the circuit boards within the outline on the board and solder the foil of the #85-2690 circuit board to the foil on the power amplifier circuit board.
- () Now solder the foils of the #85-2691 circuit board to the foils on the power amplifier circuit board.

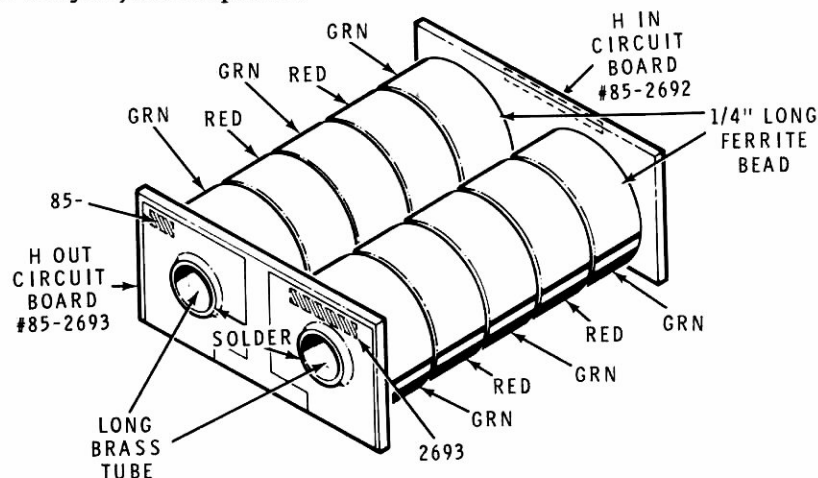

Detail 14-3B

Heathkit®

- () T1202: Similarly, solder a small transformer form at location T1202 on the power amplifier circuit board. Be sure the #85-2690 circuit board is next to holes C, D, E, F, and G on the power amplifier circuit board.
- () T1203: Solder the remaining small transformer form at location T1203 with its #85-2690 board next to holes H, I, J, K, and L on the power amplifier circuit board.

NOTE: The large transformer form will be installed later.

- () Prepare a 5" small red stranded wire.

NOTE: When you wind a wire through a transformer form, the wire should not be too loose, however, you must be careful not to pull the wire too tight against the ends of the brass tubes. These brass tube ends can be quite sharp, and could cut the insulation on the wire. This could cause "shorted turns" which would keep your Transceiver from operating properly. If the wire appears to be too long when you finish winding the transformer, you can shorten the free end as necessary.

- () Refer to Detail 14-3C and solder one end of the prepared red wire into hole AA in the power amplifier circuit board and cut off the excess wire length.
- () Again refer to Detail 14-3C and wind 2 turns on the transformer form at location T1201, by following the numbered sequence (1 through 5). Then solder the free end of the wire into hole BB in the power amplifier circuit board and cut off the excess wire lengths.
- () Prepare a 3" small red stranded wire and a 3" small black stranded wire. Do not add solder to the ends of these wires yet.
- () Twist the bare end at one end of the red wire and black wire together and melt a small amount of solder on them. Then melt a small amount of solder on the remaining two wire ends.

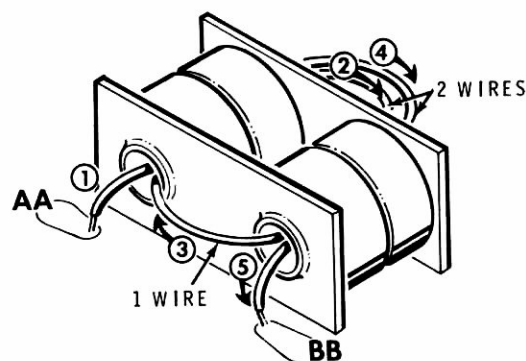

Detail 14-3C

- () Refer to Detail 14-3D (Illustration Booklet, Page 19) Part A and solder the combined end of the red and black wires into hole E of the power amplifier circuit board.
- () Refer to Part A of the Detail and wind the black wire 1 turn on the transformer form at location T1202 by following the numbered sequence (1 through 3) and arrow direction. Then solder its free end into hole F.

NOTE: If you can not get a wire through the brass tube, **carefully** push a large bare wire through the tube to make a passageway for the wire.

- () Refer to Part B of the Detail and wind the red wire 1 turn on the transformer form and solder its free end into hole D.
- () Remove 3/16" of insulation from both ends of two 1-5/8" small white solid wires. Then bend a small loop at one end of each wire.
- () Refer to Part C of the Detail and cut both leads of a 22 Ω (red-red-blk) 1/4-watt resistor to 3/16" long. Bend small loops in each resistor lead and connect the looped end of a white wire to each resistor lead. Bend the loops on the wire ends and the resistor closed. Make these connections as small as possible.
- () Now solder the connections of the resistor and white wires. Do not use any more solder than necessary to make a good connection.

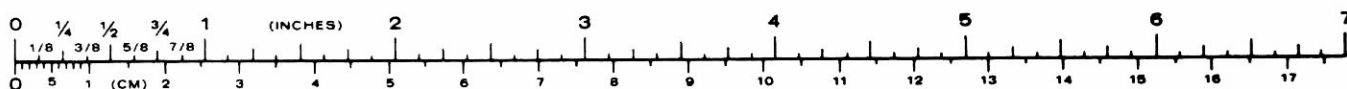

- () Refer again to Part C of the Detail and cut 3/16" long slits at both ends of a 3/4" length of fiber sleeving. Be sure the slits are aligned with each other. Slide the sleeving over the resistor/wire assembly. Center the sleeving on the resistor and bend the white wires into the slots of the sleeving.
 - () R1206: Refer to Part D of the Detail and push the white wires through the brass tubes in transformer form T1202 until the sleeving is 1/8" from the form. Then bend the white wires and sleeving up against the form.
 - () Refer again to Part D of the Detail and slide a 1/8" long ferrite bead on the free end of each white wire. Now solder these wires into holes C and G of the power amplifier circuit board and cut off any excess wire lengths.
 - () C1211: Refer to Detail 14-3E (Illustration Booklet, Page 20) and cut both leads of a 1000 pF mica capacitor to 1/4" long. Position the body of the capacitor on top of transformer form T1203. Bend the capacitor leads over the edge of circuit board #85-2691 (see Pictorial 14-3) and solder the leads to the foils of the circuit board.
 - () Prepare a 3" small red stranded wire and a 3" small black stranded wire. Do not add solder to the ends of these wires yet.
 - () Twist the bare end at one end of the red and black wire together and melt a small amount of solder on them. Then melt a small amount of solder on the remaining two wire ends.
 - () Refer to Part B of the Detail and solder the combined ends of the red and black wires into hole J of the power amplifier circuit board.
 - () Refer again to Part B of the Detail and wind the black wire 1 turn on the transformer form at location T1203 as you did at transformer T1202. Now solder the free end of the black wire into hole L in the power amplifier circuit board.
 - () Refer again to Part B of the Detail and wind the red wire 1 turn on transformer form T1203 and solder its free end into hole H in the power amplifier circuit board.
 - () Remove 3/16" of insulation from both ends of two 1-5/8" small white solid wires and bend a small loop in one end of each wire.
 - () Cut both leads of a 47 Ω (yel-viol-blk) 1/4-watt resistor to 3/16" long. Bend a small loop in each resistor lead and connect the looped end of a white wire to each resistor lead. Bend the loops closed and solder both connections.
 - () Cut a 3/16" long slit at each end of a 3/4" length of fiber sleeving.
 - () Slide the sleeving over the resistor/wire assembly. Center the sleeving on the resistor and bend the white wires into the slits in the sleeving.
 - () R1213: Refer to Part C of the Detail and push the white wires through the brass tubes in transformer form T1203 until the sleeving is 1/8" from the form. Then bend the white wires and the sleeving up against the form.
 - () Refer again to Part C of the Detail and slide a 1/8" long ferrite bead on the free end of each white wire. Now solder these wires into hole I and K in the power amplifier circuit board. Cut off the excess wire lengths.
- Refer to inset drawing #2 on Pictorial 14-3 for the following steps.
- () T1204: Use the following procedure to mount the large transformer form on the circuit board:
 1. Position the large transformer form over location T1204 on the power amplifier circuit board. Be sure circuit board #85-2693 is towards the left end of the power amplifier circuit board.
 2. Position the transformer form toward the left as far as possible.

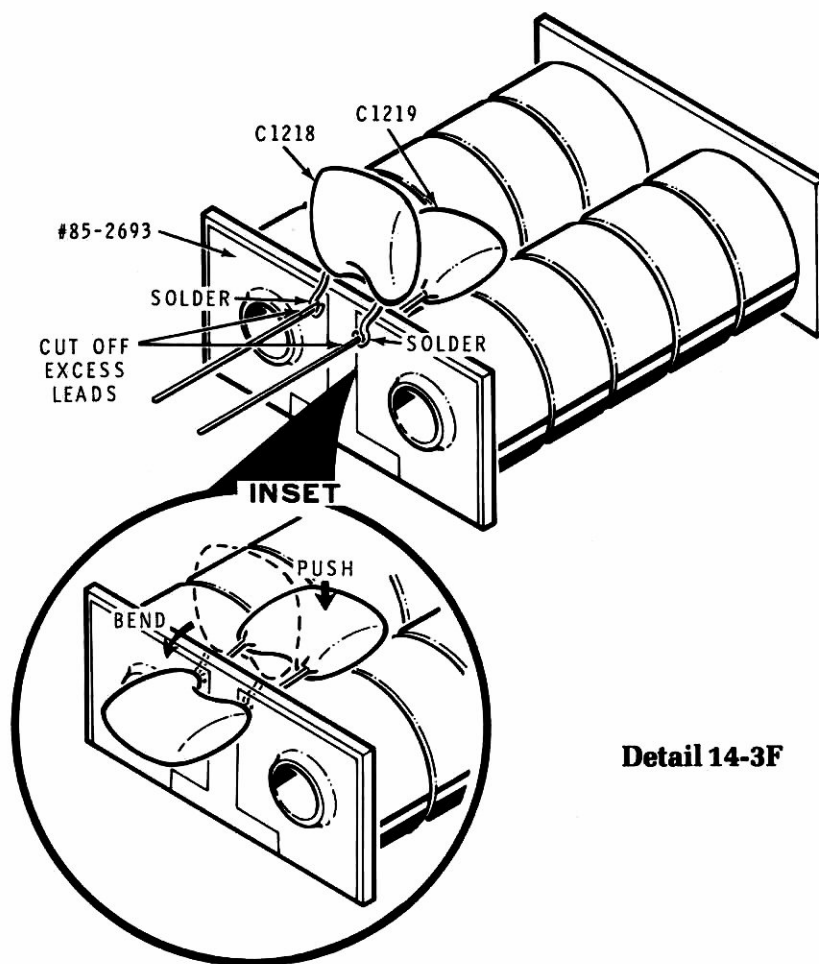

Detail 14-3F

3. Solder the foils on circuit board #85-2693 to the foils on the power amplifier circuit board. Be sure to use enough solder to ensure a good connection. NOTE: You may have to position the transformer back toward the right a small amount to expose the foil on the power amplifier circuit board.
 4. Solder the foils on circuit board #85-2692 to the foil on the power amplifier circuit board.
- () C1219: Start the leads of a 400 pF mica capacitor into the holes of circuit board #85-2693 as shown in Detail 14-3F. Then push the capacitor toward the circuit board as far as possible. Do not solder the leads or cut them off yet.
 - () C1218: Cut both leads of a 470 pF mica capacitor to 1/4" in length. Refer again to Detail 14-3F and bend small loops in these leads and then bend them around the leads of capacitor C1219. Then solder all four capacitor leads to the foils of circuit board #85-2693.
 - () Refer again to Detail 14-3F and cut off the excess leads of capacitor C1219. Then bend capacitor C1218 down as shown in the inset drawing.



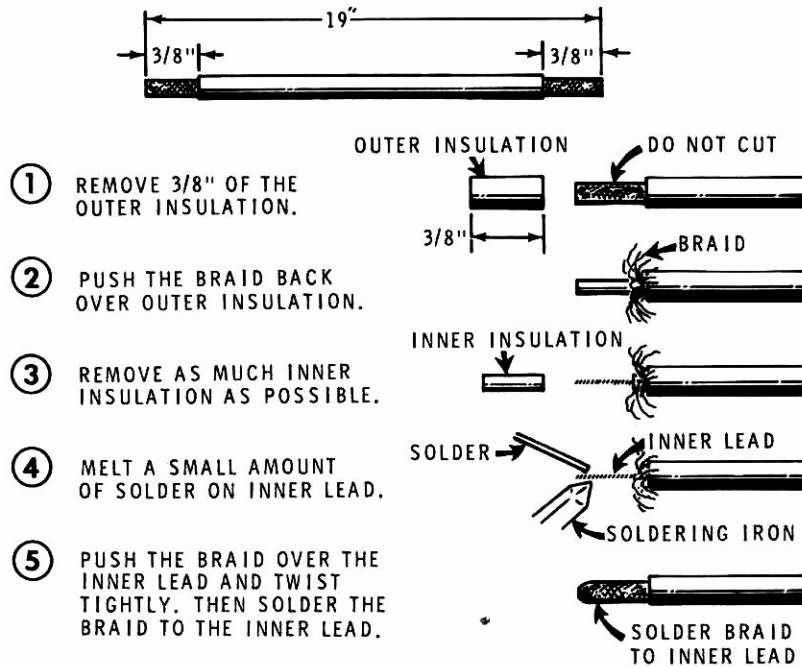

Detail 14-3G

() Refer to Detail 14-3G and prepare both ends of a 19" white shielded cable as shown. NOTE: The object is to connect the inner lead to the braid of the cable at both ends.

NOTE: In the following steps, you will be instructed to wind this shielded cable on the large transformer form. This cable is quite stiff and is difficult to work

with. Work carefully and form the cable with both hands. Wind it snug but do not make the windings too tight. Also, be careful not to cut the outer insulation on the sharp ends of the brass tubes. If you cannot get the cable through the brass tubes, carefully work the shank end, not the pointed end, of a 1/8" diameter drill bit through the brass tubes to make a passageway for the cable.

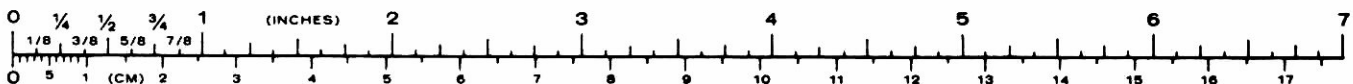

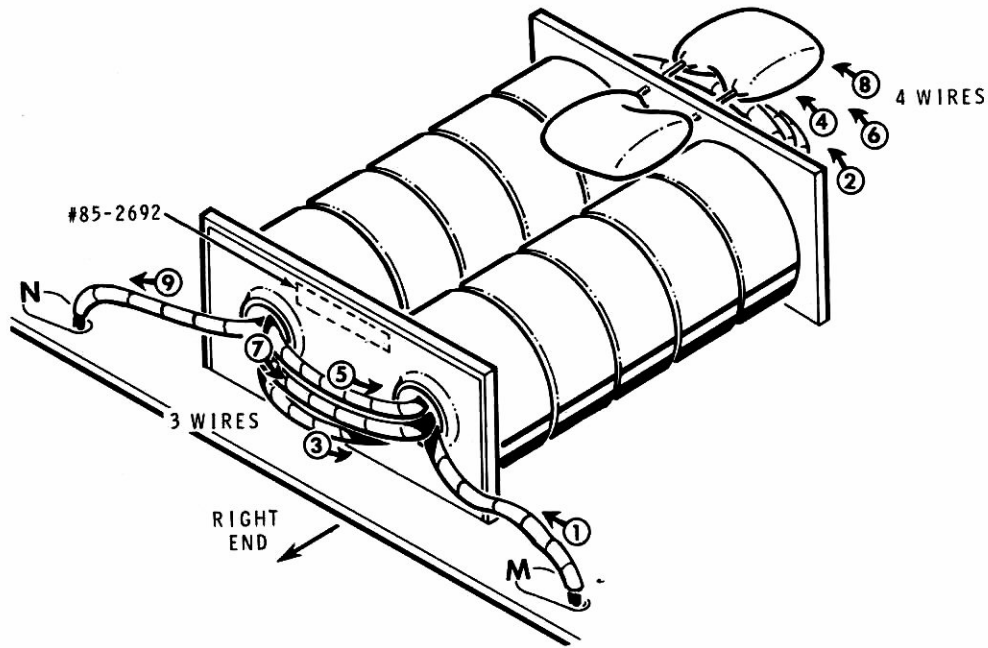

Detail 14-3H

- () Refer to Detail 14-3H and turn the power amplifier circuit board so the right end is facing you.
- () Refer again to Detail 14-3H and solder one end of the prepared shielded cable into hole M in the power amplifier circuit board.

NOTE: When you wind the cable around the transformer, in the next step, avoid (as much as possible) any overlapping of the cable at the right end of the power amplifier circuit board. Too much buildup of the cable will make it very difficult to install the shield over the circuit board later.

- () Refer again to Detail 14-3H, follow the numbered sequence (1 through 9) and wind 4 turns of the cable on the transformer form at location T1204.
- () Solder the free end of the cable into hole N in the power amplifier circuit board and cut off any excess cable ends.
- () Set your ohmmeter to $R \times 10K$. Then check the resistance between the ground foil on the PA circuit board near hole N and the foil on circuit board #85-2692. The ohmmeter should indicate infinity. If you do not obtain the correct indication, check the insulation on the shielded cable that you just installed.

START 

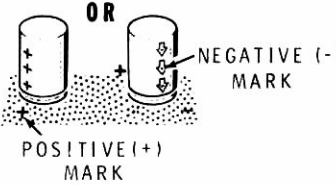
- () C1202: 39 pF mica.
 - () L1202: 10 μ H RF choke (#45-612).
 - () C1203: .01 μ F ceramic. NOTE: Your circuit board may be marked .005.
 - () C1205: 56 pF mica.
 - () L1204: 10 μ H RF choke (#45-612).
 - () C1208: 1000 pF mica.
 - () C1225: .01 μ F ceramic.
 - () C1213: .01 μ F ceramic. NOTE: You may have to scrape the solder resist from one of the foil pads for this capacitor to make soldering easier.
- NOTE: When you install an electrolytic capacitor, be sure to match the positive (+) mark on the capacitor with the positive (+) mark on the circuit board, or match the negative (-) mark on the capacitor with the negative mark on the circuit board.
- 

OR

POSITIVE (+) MARK

NEGATIVE (-) MARK
- () C1232: 100 μ F electrolytic.
 - () C1231: .005 μ F ceramic.
 - () C1217: .01 μ F ceramic. Use a 1/4" length of fiber sleeving on the indicated lead.
 - () C1224: 220 μ F electrolytic.
 - () C1223: .1 μ F Mylar.
 - () Solder the leads to the foil and cut off the excess lead lengths.

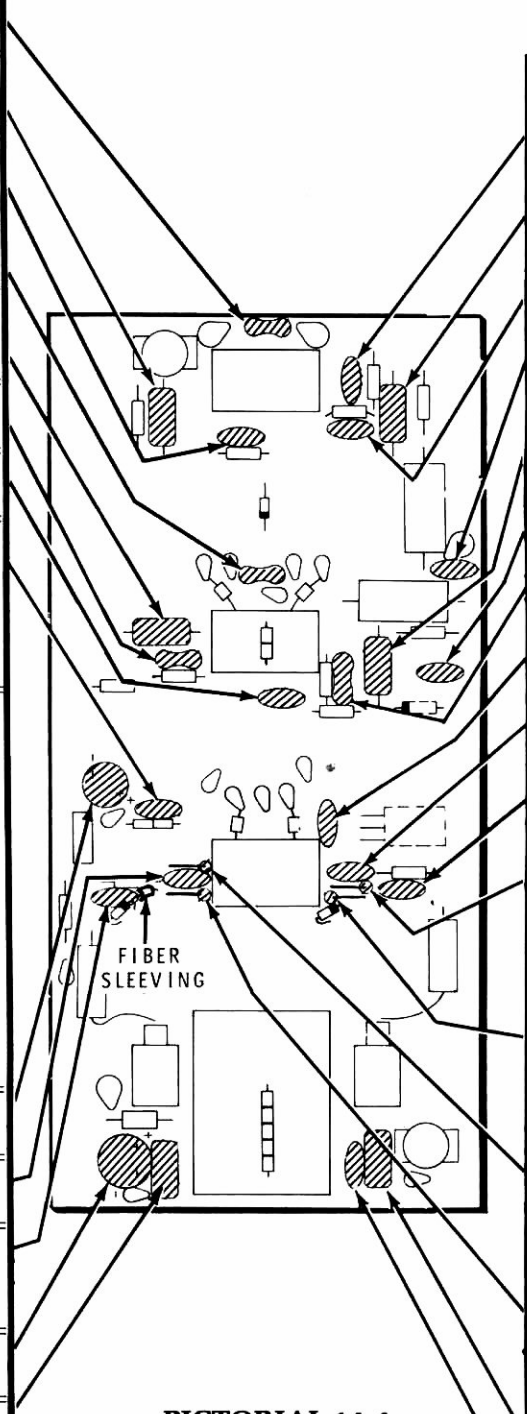

PICTORIAL 14-4

CONTINUE 

- () C1204: .01 μ F ceramic.
- () L1201: 10 μ H RF choke (#45-612).
- () C1201: .01 μ F ceramic. NOTE: Your circuit board may be marked .005.
- () C1206: .01 μ F ceramic.
- () L1203: 10 μ H RF choke (#45-612).
- () C1209: .01 μ F ceramic.
- () C1207: 1000 pF mica.
- () C1212: .05 μ F ceramic.
- () C1229: .005 μ F ceramic.
- () C1214: .01 μ F ceramic.
- () R1222: 2.2 Ω , 1/2-watt (red-red-gold). Mount this resistor vertically. NOTE: Your circuit board may be marked 2.7.
- () R1221: 2.2 Ω , 1/2-watt (red-red-gold). Mount this resistor vertically. NOTE: Your circuit board may be marked 2.7.
- () R1224: 2.2 Ω , 1/2-watt (red-red-gold). Mount this resistor vertically. NOTE: Your circuit board may be marked 2.7.
- () R1223: 2.2 Ω , 1/2-watt (red-red-gold). Mount this resistor vertically. NOTE: Your circuit board may be marked 2.7.
- () C1221: .1 μ F Mylar.
- () C1222: .001 μ F ceramic.
- () Solder the leads to the foil and cut off the excess lead lengths.

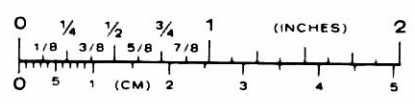

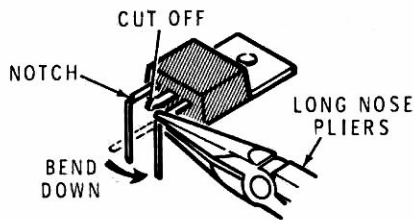

Detail 14-5A

Refer to Pictorial 14-5 (Illustration Booklet, Page 20) for the following steps.

Caution: When you bend or cut the leads of a transistor, as in the next step, you must grip the leads between the body of the transistor and then bend or cut with long-nose pliers. Otherwise you can damage the transistor.

- () Refer to Detail 14-5A and cut off the center lead of a predriver transistor (#417-971) at the notches in the lead. Then bend the remaining leads down 90° at their notches.
- () Similarly, prepare the leads of another predriver transistor (#417-971).
- () Use the following procedure to install 4-40 × 5/16" screws in the mounting holes at locations Q1201 and Q1202 of the power amplifier circuit board:
 1. Insert the screws from the foil side of the circuit board and temporarily secure them in place with 4-40 nuts.
 2. Solder the screw heads to the foil on the foil side of the circuit board.
 3. After the solder cools, remove the 4-40 nuts and set them aside. You will need them later.

WARNING: You will be using Dow Corning 340 thermal compound in the next step. Although the compound is not caustic, it may cause discomfort if it gets into your eyes. If this happens, rinse your eyes with warm water. If the compound gets onto your clothing, the clothing may require professional cleaning. The compound contains Zinc Oxides, SiO₂, and slight traces of CO₂.

- () Place a dab of thermal compound on diode D1201. Use enough compound to touch both of the transistor heat sinks that will be mounted at locations Q1201 and Q1202 later. See Detail 14-5B (Illustration Booklet, Page 21).
- () Refer again to Detail 14-5B and spread a thin coating of thermal compound on the rear of the two prepared predriver transistors.
- () Q1201: Refer again to Detail 14-5B and mount a transistor heat sink and one of the prepared transistors at location Q1201 with a #4 lock-washer and a 4-40 nut. Then solder the leads to the foil on the component side of the circuit board and cut off the excess lead lengths from the foil side.
- () Q1202: Similarly, install the other transistor heat sink and prepared transistor at location Q1202.

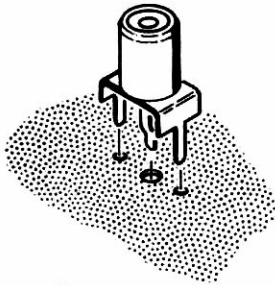

Detail 14-5C

- () S1201: Refer to Detail 14-5C and install a phono socket (circuit board mount) at location S1201. Solder all three pins to the foil.
- () S1202: Similarly, install a phono socket (circuit board mount) at location S1202.
- () R1205: Install a 150 Ω , 2-watt (brn-grn-brn) resistor at its location on the circuit board. Solder its leads to the foil and cut off the excess lead lengths.
- () R1207: Similarly, install a 120 Ω , 5-watt wirewound resistor at its location on the circuit board. Space this resistor 1/8" to 1/4" above the circuit board.
- () Remove four 1/4" lengths of insulation from the small white solid wire. Place these lengths of insulation on the leads of two 1N4448 diodes (#56-652).
- () D1203: Align the band on one of the prepared diodes with the band on the circuit board at location D1203. Insert the leads in their holes until the insulation is against the board. Then solder the leads to the foil and cut off the excess lead lengths.
- () D1204: Similarly, install the other prepared diode at location D1204 on the circuit board.
- () R1215: Install the 750 Ω control (#10-295) at its location on the circuit board. Solder its pins to the foil.

Set the circuit board aside temporarily.

Refer to Pictorial 14-6 (Illustration Booklet, Page 21) for the following steps.

- () S654: Refer to Detail 14-6A (Illustration Booklet, Page 22) and mount a coaxial socket at location S654 on the rear panel with the nut furnished with the socket. Discard the other hardware furnished with the socket.
- () SW2: Mount the slide switch on the rear panel at location SW2 with two 6-32 \times 1/4" black phillips head screws. Position the switch so its lugs are oriented as shown.
- () J1: Mount the phono socket at location J1 on the rear panel with 6-32 \times 1/4" black phillips head hardware. Position the phono socket so its lugs are oriented as shown.

Set the rear panel aside temporarily.

- () Position the large heat sink so the mounting hole for Q1205 is located as shown in Detail 14-6A.
- () Install a 6-32 \times 3/4" threaded stud in hole F in the large heat sink. Be sure the slot in the screw is up, and adjust the screw so it extends 1/2" out of the heat sink.
- () Similarly, install 6-32 \times 3/4" threaded studs in holes A through E in the heat sink.
- () Center the rear panel on the heat sink and secure the rear panel with a 6-32 nut on each threaded stud. Be sure the threaded studs do not turn.
- () Position the power amplifier circuit board onto the heat sink. Be sure the circuit board part number is located as shown. Use two #6 lockwashers on each threaded stud (one below and one above the circuit board). Secure the circuit board with four 1/4" \times 7/8" tapped spacers and two 6-32 nuts. Turn the hardware only finger tight at this time.

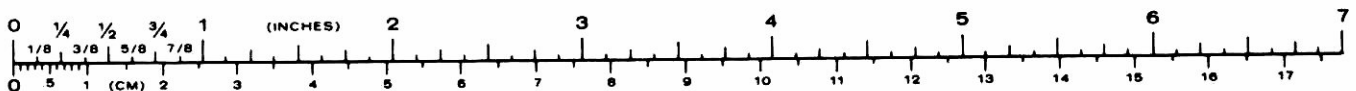

Heathkit®

- () At the mounting location for transistor Q1205, measure the distance between the center of the mounting hole in the large heat sink and the lead holes in the circuit board. Write this dimension in the box above the word "MEASURE" on Pictorial 14-6. This dimension will be used later.
- () Locate the matched final transistors (package #117-16). Then refer to Detail 14-6B and carefully bend approximately 1/8" of each lead on each transistor straight up. NOTE: This makes it easier to remove the transistors, if this should ever become necessary.
- () Q1206: Refer again to Detail 14-6B and mount one of the matched final transistors at location Q1206 on the heat sink with two 4-40 × 1/4" black allen head screws. Position the transistor so the angled tab is located as shown. NOTE: Do not apply thermal compound to the transistor yet.
- () Now solder the three indicated tabs on the transistor Q1206 to their foil on the lettered side of the circuit board. The remaining tab will be soldered later.
- () Q1207: Similarly, mount and solder the three indicated tabs of the other matched final transistor at location Q1207. NOTE: Do not apply thermal compound to the transistor yet.

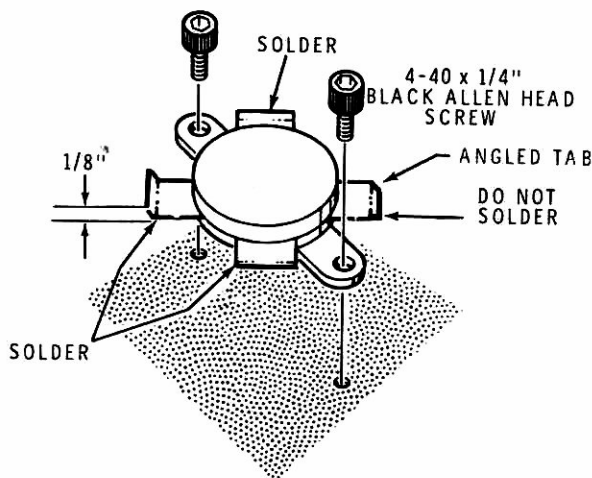

Detail 14-6B

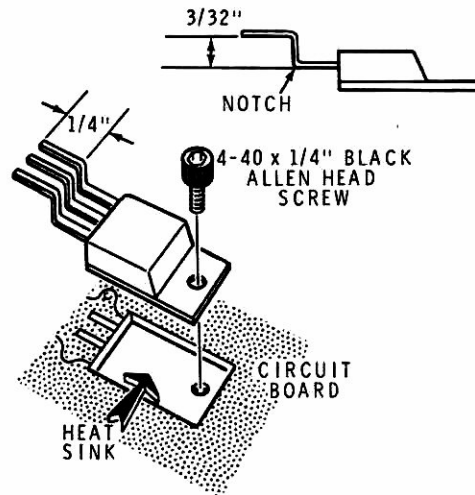

Detail 14-6C

- () Refer to Detail 14-6C and bend the leads of two driver transistors (#417-972). Hold the leads between the transistor body and the bend so you do not damage the transistor. Then shorten the indicated portion of the leads to 1/4".
- () Q1203: Mount one of the prepared transistors at location Q1203 with a 4-40 × 1/4" black allen head screw into the heat sink. Solder the transistor leads to their foils on the printed side of the circuit board.
- () Q1204: Similarly, install the other prepared transistor at location Q1204.
- () Remove the 4-40 × 1/4" black allen head screws from transistors Q1203, Q1204, Q1205, and Q1206. Save these screws for use later.
- () Remove the four spacers, two 6-32 nuts, and six lockwashers that secure the circuit board to the heat sink and remove the circuit board. Save the spacers, nuts and lockwashers for use later.

Refer to Pictorial 14-7 (Illustration Booklet, Page 23) for the following steps.

- () R1216: Install a 100 Ω , 2-watt (brn-blk-brn) resistor at its location on the power amplifier circuit board. The lead at the left end of the resistor must be soldered on the foil side of the circuit board. When you solder the other lead to the foil on the lettered side of the board, also solder the tab of transistor Q1206 and the tab of capacitor C1215 to the same foil. Then cut off the excess lead length on the foil side of the board.
- () R1219: Similarly, install a 100 Ω , 2-watt (brn-blk-brn) resistor at its location on the circuit board.

NOTE: The diode and transistor that you will be instructed to install in the next three steps are to be located on the **foil side** of the circuit board. Also, you will solder their leads to the foils on the **foil side** of the board.

- () D1202: Install a 1N2071 diode (#57-27) on the foil side of the circuit board. Be sure to align its band with the band shown on the lettered side of the circuit board.
- () Q1205: Find the dimension you placed in the box on Pictorial 14-6. Refer to Detail 14-7A and bend the leads of a MJE181 transistor (#417-818) to this dimension. Bend the leads away from the metal side of the transistor.
- () Install the transistor, metal side up, at location Q1205 on the foil side of the circuit board. Solder the leads to their foils.
- () Now cut off the excess diode and transistor leads on the lettered side of the circuit board.
- () Prepare a 6" small white stranded wire. Solder one end of this wire into hole CC of the circuit board.

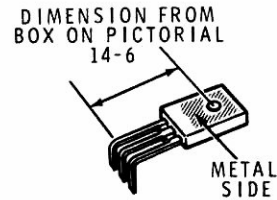

Detail 14-7A

- () Prepare a 3-1/2" small white stranded wire and solder one end into hole A of the circuit board.
- () Prepare a 4-1/2" small white stranded wire and solder one end into hole B of the circuit board.
- () Prepare a 4" large red stranded wire and solder one end into hole P of the circuit board.
- () Cut off excess lead lengths of these wires. Their free ends will be connected later.

Refer to Pictorial 14-8 (Illustration Booklet, Page 24) for the following steps.

- () Reposition the power amplifier circuit board back into place on the rear panel. Look between the circuit board and the heat sink. If there are leads that touch the heat sink, cut them off.
- () Temporarily remove the power amplifier circuit board from the rear panel.
- () Refer to Detail 14-8A (Illustration Booklet, Page 25) and apply a thin coating of thermal compound to one side of the transistor insulator. Then press the coated side against the large heat sink at the location of transistor Q1205. Align the hole in the insulator with the hole in the heat sink.
- () Apply a thick coating of thermal compound to the rear sides (the side on the foil side of the circuit board) of transistors Q1203, Q1204, Q1205, Q1206, and Q1207. Save a small amount of the thermal compound for use later.

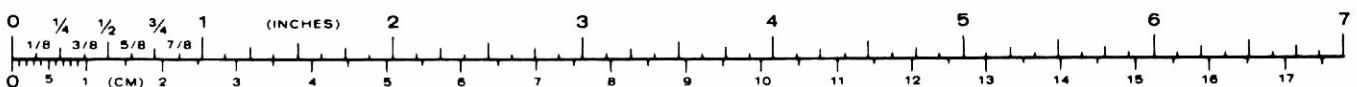

Heathkit[®]

- () Check to see that there is a #6 lockwasher on each of the threaded studs at locations A through F.
 - () Position the power amplifier circuit board into place on the rear panel.
 - () Refer again to Detail 14-8A and start a 4-40 × 1/4" screw through the hole in transistor Q1205, its insulator and into the hole in the heat sink. Be sure the insulator does not move; it must keep the metal side of the transistor from touching the heat sink. Do not tighten the screw at this time.
 - () Start six 4-40 × 1/4" black allen head screws into the holes in transistors Q1203, Q1204, Q1206, and Q1027.
 - () Now tighten all seven transistor mounting screws. DO NOT overtighten the screw in transistor Q1205 as you could damage the transistor.
 - () Now secure the circuit board in place with a #6 lockwasher and a 1/4" × 7/8" tapped spacer on each threaded stud at locations A, C, D, and F. Use #6 lockwashers and 6-32 nuts to secure the circuit board at locations B and E.
 - () Refer to inset drawing #1 on Detail 14-8A and install an 8-32 × 1-1/4" screw in the center hole of the ALC circuit board. Use a #8 lockwasher and two 8-32 nuts. Tighten the first nut against the lockwasher and foil side of the board. Adjust the second nut so its bottom side is 1/4" from the foil side of the circuit board.
 - () Refer to inset drawing #2 on Detail 14-8A and mount the ALC circuit board onto the rear panel. Use a #8 lockwasher, an 8-32 nut, two #8 flat washers, and an 8-32 wingnut on the 8-32 × 1-1/4" screw. Tighten the 8-32 nut against the lockwasher and rear panel. Finger tighten the wingnut. Use a 6-32 × 5/8" black phillips head screw, a 1/4" × 1/4" spacer, a #6 lockwasher, and a 6-32 nut at the small hole at the end of the board. Make sure both phono sockets are centered in their holes before you tighten the hardware.
 - () C1225-C1226-C1227-C1228: Refer to inset drawing #1 on Pictorial 14-8 and install .001 μF (1000 pF) feedthrough capacitors at locations C1225 through C1228 on the power amplifier shield. Install the nuts on the outside of the shield. Be sure to mount each capacitor so the hook in the end of the lead is facing the same way, as shown in the Pictorial.
 - () Cut a 1" × 2" piece from the insulator. Remove the protective backing and press the insulator into place on the inside of the right end of the shield.
- NOTE: In the following steps, (NS) means not to solder the connection because you will add other wires later. "S-" with a number, such as (S-2), means to solder the connection. The number following the "S-" tells you how many wires should be at the connection. This helps you check your work as you go.
- Connect the free ends of the wires coming from the power amplifier circuit board to the feedthrough capacitors on the shield as follows:
- () Small white wire from hole A to C1225 (S-1).
 - () Small white wires from holes B and CC to C1226 (S-2).
 - () Remove an extra 3/8" of insulation (total 5/8") from the large red wire coming from hole P. Then solder the wire to C1227 and C1228.
 - () Solder the wire coming from the center of coil L651 and the bare wire from hole A on the ALC circuit board into socket S654, which protrudes through the board.
 - () Apply a dab of thermal compound on diode D1203 and then push the diode onto the top of transistor Q1206.
 - () Similarly, apply thermal compound to diode D1204 and press the diode onto the top of transistor Q1027.
 - () Refer to inset drawing #2 on Pictorial 14-8 and turn the power amplifier shield over and position it down over the power amplifier circuit board. Secure the shield in place with four 6-32 × 1/4" black phillips head screws into the tops of the spacers. Be sure to use #6 solder lugs at locations HC and HD. Also be sure to position the solder lugs as shown in the Pictorial. DO NOT pinch the wires between the rear panel and the shield.

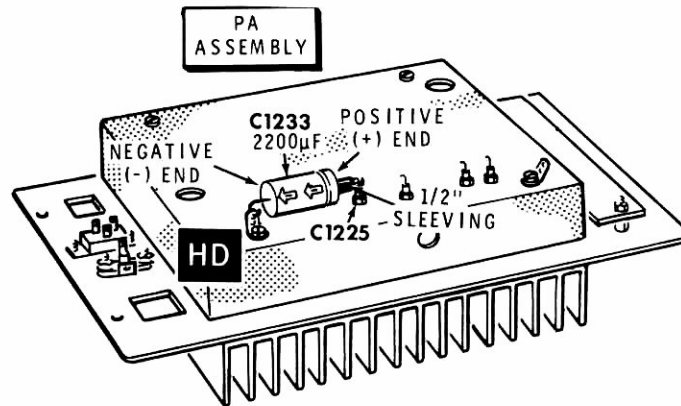

PICTORIAL 14-9

- () C1233: Cut both leads of a 2200 μF electrolytic capacitor to 3/4". Then refer to Pictorial 14-9 and connect the lead at the negative (-) end of this capacitor to solder lug HD (S-1). Slide a 1/2" length of small black sleeving onto the lead at the positive (+) end of this capacitor. Then connect the lead to feedthrough capacitor C1225 (NS).
- () Feedthrough capacitors C1227 and C1228. 100 Ω or greater. Check transistors Q1206, Q1207, and their associated components, transformer T1204, and the circuit board for solder bridges. (R \times 10).
- () Feedthrough capacitor C1225. Approximately 150 Ω . Check diodes D1203, D1204, transistor Q1205, and the associated circuits, and the circuit board foils.

INITIAL TESTS

Refer to Pictorial 14-10 for the following steps.

- () Connect the common lead of your ohmmeter to the rear panel.

Use the positive ohmmeter probe to check the PA assembly for the following readings. As in the previous sections, the steps are abbreviated.

NOTE: Do not change the ohmmeter range unless a step directs you to do so.

- () Feedthrough capacitor C1226. Approximately 150 Ω . Check transistors Q1201 through Q1205 and their associated components. Also check transformers T1202 and T1203 for the correct wiring, and the circuit board for solder bridges.

This completes the "Initial Tests" of your amplifier assembly. Set the assembly aside until it is called for during the assembly of the chassis. Proceed to "Chassis".

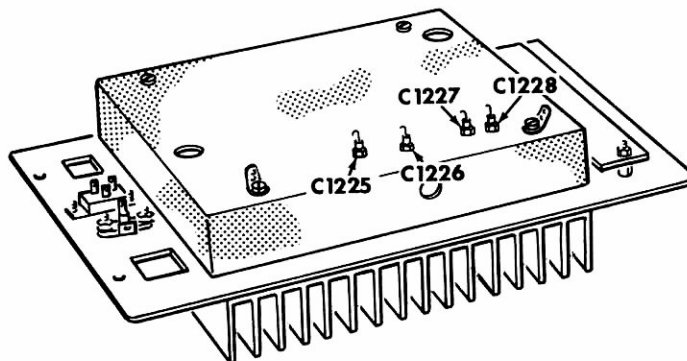

PICTORIAL 14-10

CHASSIS

PARTS LIST

() Unpack the remainder of the kit and check each part against the following list. The key numbers correspond to the numbers on the "Chassis Parts Pictorial" (Illustration Booklet, Pages 26 through 29). Return any part that is packed in an individual envelope, with the part number on it, back into its envelope until that part is called for in a step. Do not throw away any

packing material until you account for all the parts.

To order a replacement part, always include the PART NUMBER. Use the Parts Order Form furnished with this kit. If a Parts Order Form is not available, refer to "Replacement Parts" inside the rear cover of this Manual. For prices, refer to the separate "Heath Parts Price List."

KEY No.	HEATH Part No.	QTY.	DESCRIPTION	CIRCUIT Comp. No.
ELECTRONIC COMPONENTS				
A1	6-100-2	1	10 Ω , 2-watt, 5% resistor	Test
A1	6-470	2	47 Ω , 1/2-watt, 5% resistor (yel-viol-blk)	R5, Test
A2	12-181	1	Dual 10 k Ω control	R4A/R4B
A3	14-22	1	Dual 1 k Ω /250 k Ω control with switch	R2A/R2B/SW3
A2	12-183	1	Dual 10 k Ω /1 k Ω control with center detent	R3A/R3B
A4	21-143	5	.05 μ F ceramic capacitor	C4, C5, C6, C7, C8
A5	25-877	1	2200 μ F electrolytic capacitor	C3
A6	45-98	1	Hash filter choke	L1
A4	21-742	1	22 pF ceramic capacitor	Test

KEY No.	HEATH Part No.	QTY.	DESCRIPTION	CIRCUIT Comp. No.
Electronic Components (Cont'd.)				
A7	57-35	1	1N3491R diode	D3
A8	63-1384	1	4-position rotary switch	SW9
A9	63-1385	1	1-wafer, 8-position rotary switch	SW1A
A10	63-1387	1	2-wafer, 8-position rotary switch	SW1B/SW1C
A11	64-894	1	3-section pushbutton switch (momentary contact)	SW6/SW7/SW8
A11	64-898	1	3-section pushbutton switch (locking)	SW3/SW4/SW5
A12	69-90	1	Relay	K1
A13	407-761	1	Meter	M1
A14	442-713	1	LM383 IC	U906
A15	442-54	2	UA7805 IC	U714, U715

KEY No.	HEATH Part No.	QTY.	DESCRIPTION	CIRCUIT Comp. No.
---------	----------------	------	-------------	-------------------

KEY No.	HEATH Part No.	QTY.	DESCRIPTION	CIRCUIT Comp. No.
---------	----------------	------	-------------	-------------------

HARDWARE

NOTE: Hardware packets are marked to show the size of the hardware they contain (HDW #4, or HDW #6 & #8, etc.). You may have to open more than one packet to locate all of the hardware of any one size (#6, for example).

#4 Hardware

B1	250-156	4	4-40 × 1/8" setscrew	
B2	250-1411	2	4-40 × 1/4" black phillips-head screw	
B3	250-322	4	4-40 × 1/2" flat head screw	
B4	250-1462	6	#4 × 3/16" black sheet metal screw	
B5	250-1226	5	#4 × 1/4" self-tapping screw	
B6	252-2	3	Large 4-40 nut	
B7	252-15	4	Small 4-40 nut	
B8	253-82	1	#4 flat washer	
B9	254-9	2	#4 lockwasher	
B10	259-9	1	#4 solder lug	

#6 Hardware

C1	250-1282	9	6-32 × 1/8" setscrew	
C2	250-70	4	6-32 × 3/16" flat head screw	
C3	250-230	2	6-32 × 3/16" setscrew	
C4	250-1325	8	6-32 × 1/4" black phillips head screw	
C5	250-365	29	#6 × 1/4" hex head sheet metal screw	
C6	250-1425	4	6-32 × 1/2" black phillips head screw	
C7	250-1431	3	#6 × 3/8" black flat head sheet metal screw	
C8	250-475	8	#6 × 3/8" hex head sheet metal screw	
C9	250-1280	4	6-32 × 3/8" black phillips head screw	
C10	250-1264	37	6-32 × 3/8" hex head screw	
C11	250-1331	4	6-32 × 5/8" black phillips head screw	
C12	250-1157	2	6-32 × 1/4" hex stud	
C13	250-1158	1	6-32 × 3/4" threaded stud	
C14	250-1284	2	6-32 × 1-1/2" black screw	
C15	250-168	2	6-32 × 1-3/8" screw	
C16	252-3	10	6-32 nut	
C17	253-60	4	#6 flat washer	
C18	254-1	10	#6 lockwasher	
C19	259-1	4	#6 solder lug	
C20	259-29	6	Long #6 solder lug	

Other Hardware

E1	252-7	7	Large control nut	
E2	252-39	2	Small control nut	
E3	252-188	5	Push-on nut	
E4	252-194	1	Decorative control nut	
E5	253-10	7	Large control flat washer	
E6	253-11	1	"E" ring	
E7	253-16	1	Fiber shoulder washer	
E8	253-36	1	Formed washer	
E9	253-39	3	1/4" flat washer	
E10	254-4	3	Large control lockwasher (thick)	
E11	254-5	2	Large control lockwasher (thin)	
E12	255-3	2	1/4" × 3/8" long spacer	
E13	255-49	6	7/32" × 5/16" long spacer	
E14	259-10	3	Large control solder lug	
E15	259-24	1	#8 solder lug	
E16	455-26	1	Brass bushing	
E17	455-642	1	Brass collar	
E18	456-7	2	Shaft coupler	
E19	205-778	1	Steel blade	

CONNECTORS

F1 *	432-120	16	Circuit board connector (includes one extra)	
F2	432-137	5	Push-on connector	
F3	432-836	1	6-pin socket shell	
F4	432-837	1	6-pin plug shell	
F5	432-854	8	Male terminal pin (includes two extra)	
F6	432-855	8	Female terminal pin (includes two extra)	
F7	432-865	4	3-pin socket shell	
F8	432-866	63	Small spring connector (includes three extra)	
F9	432-970	3	5-pin socket shell	
F10	432-1030	17	2-pin socket shell	
F11	432-1099	1	Microphone socket	J2
F12	432-1177	1	4-pin plug shell	
F13	432-1178	1	4-pin socket shell	
F14	432-1179	8	Large spring connector	
F15	436-19	1	Phone jack	J3
F16	438-46	4	Phono plug	

Heathkit®

KEY No.	HEATH Part No.	QTY.	DESCRIPTION
---------	----------------	------	-------------

SHEET METAL PARTS

G1	200-1409	1	Main chassis
G2	200-1410	1	Rear chassis
G3	203-2108-1	1	Front panel
G4	204-2618	1	Left chassis bracket
G5	204-2619	1	Right chassis bracket
G6	204-2647	1	Controller mounting bracket
G7	205-1889	1	Relay mounting plate
G8	206-1408	1	Bandswitch shield
G9	206-1409	1	Center shield
G10	206-1411	2	Filter circuit board shield
G11	206-1437	1	IF shield
G12	206-1438	1	Controller shield
G13	90-1295-1	1	Cabinet top
G14	90-1296-1	1	Cabinet bottom

GROMMETS — INSULATOR PAPER

H1	73-1	1	3/8" rubber grommet
H2	73-43	1	3/8" plastic grommet
H3	73-45	2	1/2" plastic grommet
H4	73-133	1	Grommet strip (4" long)
H5	75-103	1	1-7/8" × 5-1/2" insulator paper
H6	75-108	1	1-3/4" × 2" insulator paper

KNOBS

J1	462-1129	1	Large knob
J2	462-1130	2	Medium knob with decorative insert
J3	462-1131	3	Medium knob without decorative insert
J4	462-1132	3	Small knob
J5	462-1133	6	Pushbutton knob

KEY No.	HEATH Part No.	QTY.	DESCRIPTION
---------	----------------	------	-------------

MISCELLANEOUS

	134-1189	1	Front panel harness
	134-1190	1	Main wire harness
	134-1262	1	Cable harness
K1	203-2112	1	Plastic door
K2	210-130	1	Bezel
K3	255-59	2	Black nylon spacer
K4	258-95	4	Grounding clip
K5	261-9	4	Rubber foot
K6	266-1015	1	Encoder disc
K7	266-1201	1	Finger contact
K8	352-14	1	Grease
K9	354-5	11	Cable tie
K10	431-32	1	2-lug terminal strip
K11	446-732	1	Escutcheon
K12	446-734	1	Window
K13	453-331	1	1-7/8" shaft
K14	453-340	1	7" shaft
K15	475-12	3	5/16" ferrite bead
K16	490-1	1	Large alignment tool
K17	490-218	1	Small alignment tool

STEP-BY-STEP ASSEMBLY

Refer to Pictorial 15-1 (Illustration Booklet, Page 30) for the following steps.

- () Position the rear chassis as shown in the Pictorial. (Note the location of the larger hole near the center of the top edge in the chassis.)
- () Refer to Detail 15-1A and temporarily mount the 2-wafer, 8-position rotary switch (#63-1387) onto the rear chassis at hole RE. Use a large control lockwasher (thin), a large control flat washer, and a large control nut. Be sure to mount the switch so its lugs are positioned as shown in the Pictorial.
- () Refer to the inset drawing on the Pictorial and bend the pairs of lugs at each position on switch SW1B and C so they are touching. Whenever you connect a wire to these lugs in the following steps, be sure to connect the wire to both lugs.
- () Cut four 1" small bare wires. Use these bare wires in the following steps.

NOTE: In the following steps, (NS) means not to solder the connection because you will add other wires later. "S-" with a number, such as (S-2), means to solder the connection. The number following the "S-" tells you how many wires should be at the connection. This helps you check your work for errors as you go.

- () Connect a 1" bare wire between switch SW1B lugs 8 (S-1) and 7 (NS).
- () Connect a 1" bare wire between switch SW1B lugs 6 (S-1) and 5 (NS).
- () Connect a 1" bare wire between switch SW1C lugs 10 (NS) and 11 (S-1).
- () Connect a 1" bare wire between switch SW1C lugs 12 (NS) and 1 (S-1).
- () Cut a 5" large bare wire.

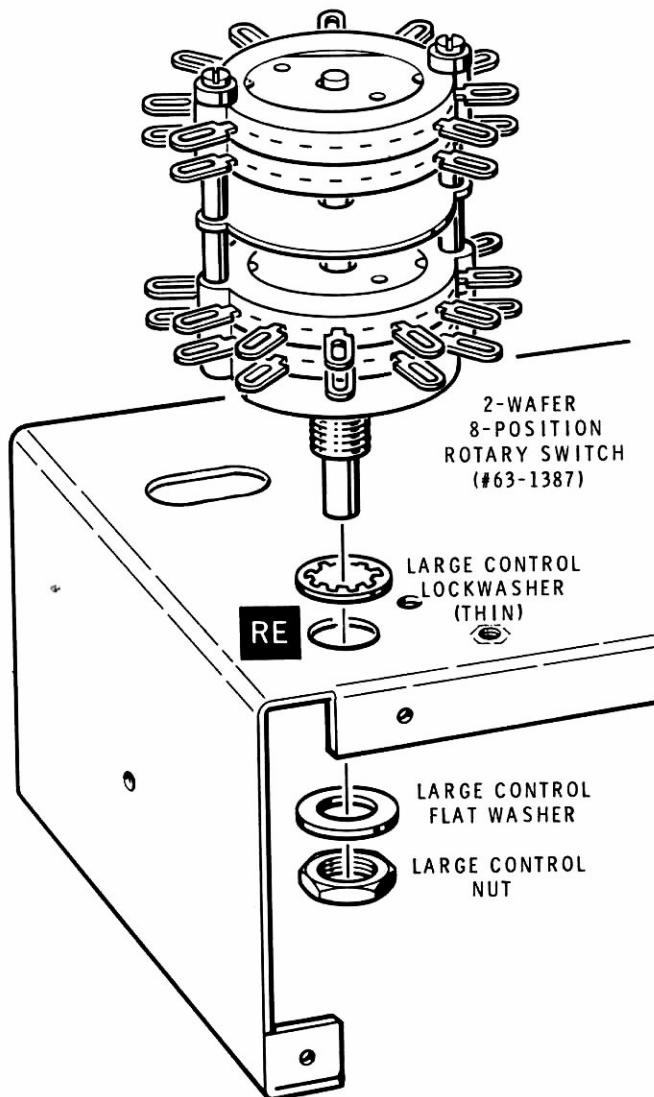

Detail 15-1A



Heathkit®

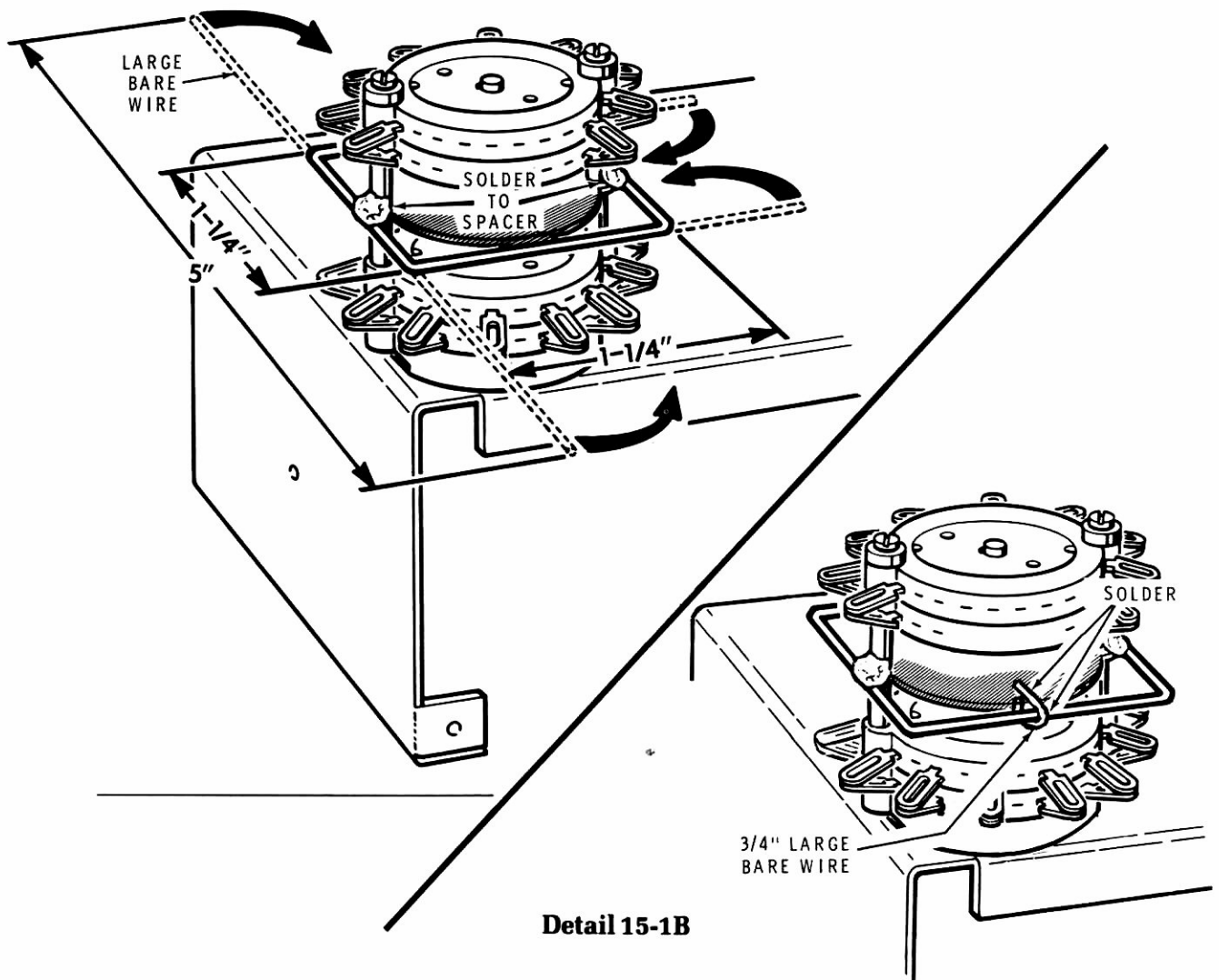

Detail 15-1B

- () Refer to Detail 15-1B and use the following procedure to form a ground buss around the center of switch SW1B/C. NOTE: You will connect wires to this buss later.
1. At a point that is exactly 2-1/2" from one end of the large bare wire, solder the wire to the indicated spacer on the switch.
 2. Form the wire into a square that is 1-1/4" on a side so the ends meet at the spacer on the opposite side of the switch. Then solder the ends of the wire to the spacer.
- () Cut two 3/4" large bare wires. Use these wires in the following steps.
- () Connect a 3/4" bare wire between the metal plate on switch SW1B/C and the ground buss. Be sure the wire is halfway between the spacers. Then solder the wire to the metal plate and the ground buss.
 - () Turn the rear chassis 180°. Then connect and solder a 3/4" bare wire between the metal plate and the ground buss on the other side of switch SW1B/C.

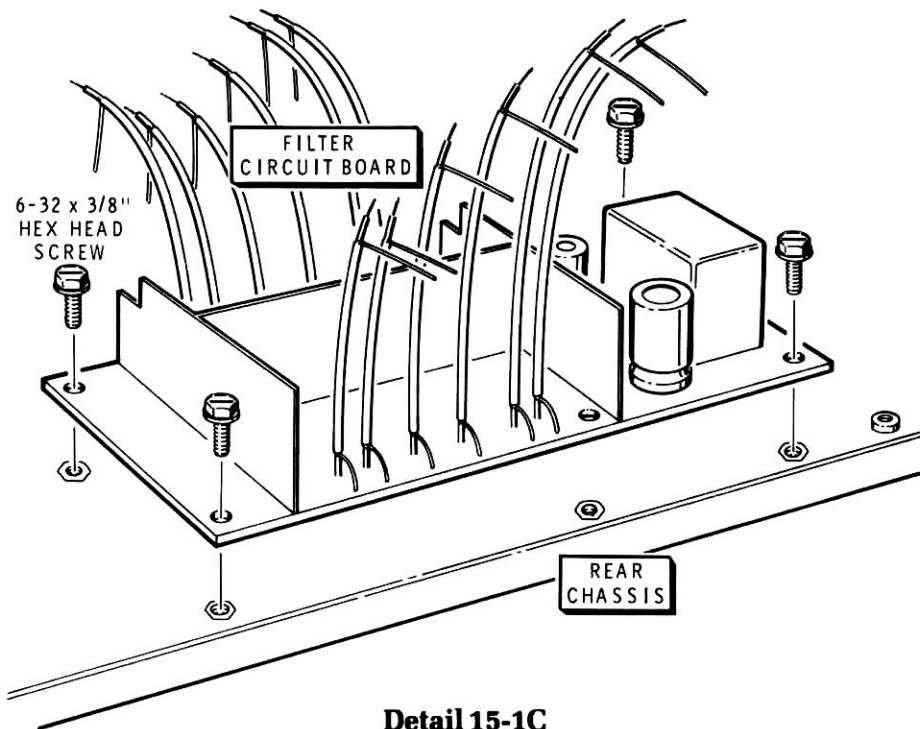

Detail 15-1C

- () Refer to Detail 15-1C and temporarily mount the filter circuit board (assembled earlier) to the rear chassis. Use four 6-32 × 3/8" hex head screws, but only tighten the hardware enough to hold the circuit board in place. NOTE: Keep the shield leads as short as possible to make sure they cannot touch any switch lugs.
- () Inner lead of the cable coming from holes 10 to switch lugs 7 (S-2) and the shield lead to the ground bus (S-1).
- () Inner lead of the cable coming from holes 15 to switch lugs 5 (S-2) and the shield lead to the ground bus (S-1).
- () Inner lead of the cable coming from holes 20 to switch lugs 4 (S-1) and the shield lead to the ground bus (S-1).
- () Inner lead of the cable coming from holes 30 to switch lugs 3 (S-1) and the shield lead to the ground bus (S-1).
- () Inner lead of the cable coming from holes 40 to switch lugs 2 (S-1) and the shield lead to the ground bus (S-1).
- () Inner lead of the cable coming from holes 80 to switch lugs 1 (S-1) and the shield lead to the ground bus (S-1).
- () Route the cable coming from holes A and B as shown. Then connect the inner lead of this cable to switch SW1B lugs 12 (NS) and the shield lead to the ground bus (S-1).
- () Cut a 6" length and an 8" length of white shielded cable.

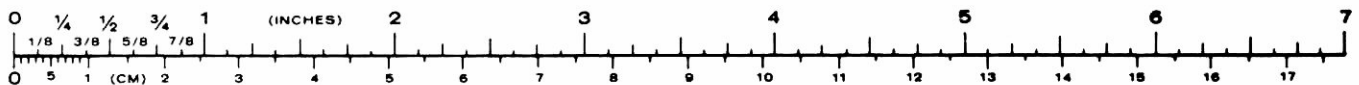

Heathkit[®]

- () Refer to Detail 15-1D and prepare both ends of each shielded cable as shown.
- () Refer to Detail 15-1E and install a phono plug on **end B** of each shielded cable as shown.
- () Connect the inner lead at the free end of the 8" prepared shielded cable to switch SW1B lugs 12 (S-2); connect the shield lead to the ground bus (S-1) and the metal plate between switch sections B and C (S-1). Be sure you solder the shield wires to the plate close to the nearby spacer.
- () Connect the inner lead at the free end of the 6" prepared shielded cable to switch SW1C lugs 5 (S-1) and the shield lead only to the metal plate (S-1).

Connect the shielded cables coming from the top edge of the filter circuit board to switch SW1C as follows:

- () Inner lead of the cable coming from holes 80 to switch lugs 6 (S-1) and the shield lead to the ground bus (S-1).
- () Inner lead of the cable coming from hole 40 to switch lugs 7 (S-1) and the shield lead to the ground bus (S-1).
- () Inner lead of the cable coming from holes 30 to switch lugs 8 (S-1) and the shield lead to the ground bus (S-1).
- () Inner lead of the cable coming from holes 20 to switch lugs 9 (S-1) and the shield lead to the ground bus (S-1).
- () Inner lead of the cable coming from holes 15 to switch lugs 10 (S-2) and the shield lead to the ground bus (S-1).
- () Inner lead of the cable coming from holes 10 to switch lugs 12 (S-2) and the shield lead to the ground bus (S-1).
- () Carefully remove the filter circuit board and wafer switch from the rear chassis. Then set the circuit board, the rear chassis, and the hardware aside for use later.

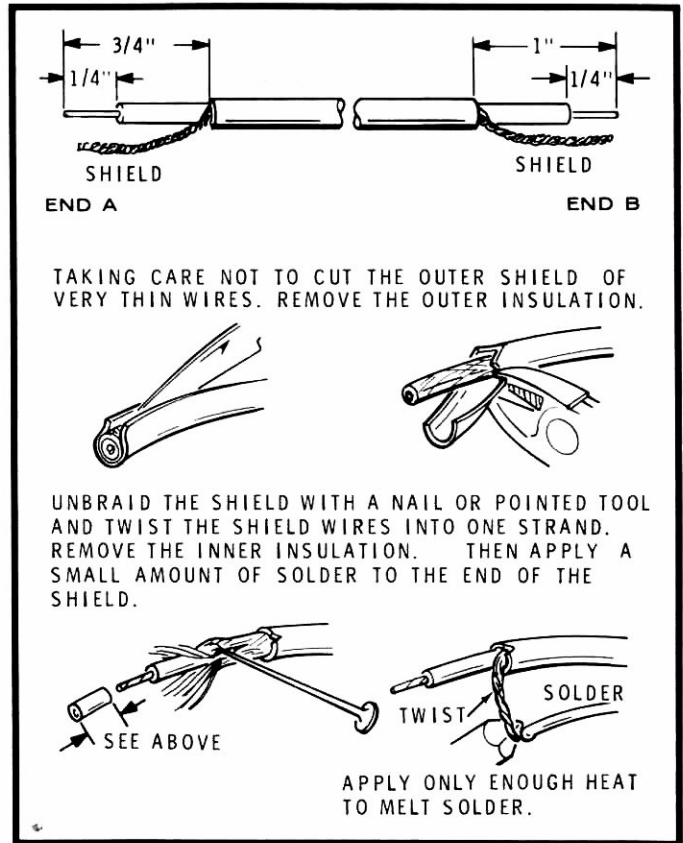

Detail 15-1D

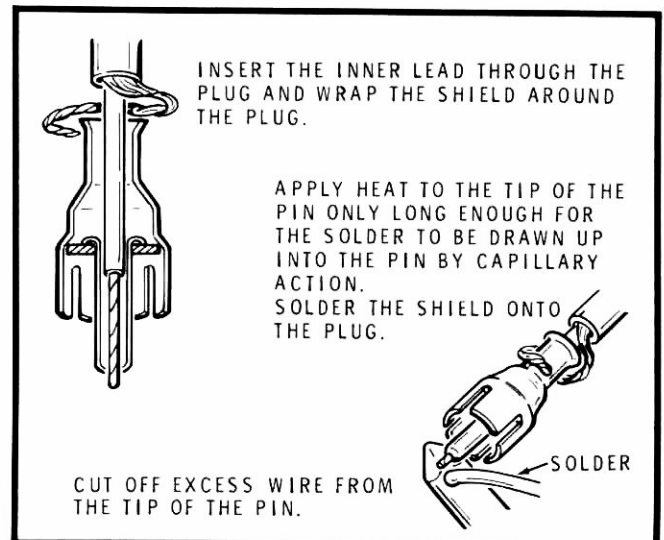

Detail 15-1E

Refer to Pictorial 15-2 for the following steps.

() Position the main chassis as shown in the Pictorial.

() Refer to Detail 15-2A and install a 1/2" plastic grommet in hole A of the main chassis.

() Refer to Detail 15-2B Part A and cut a 2-3/16" length of grommet strip.

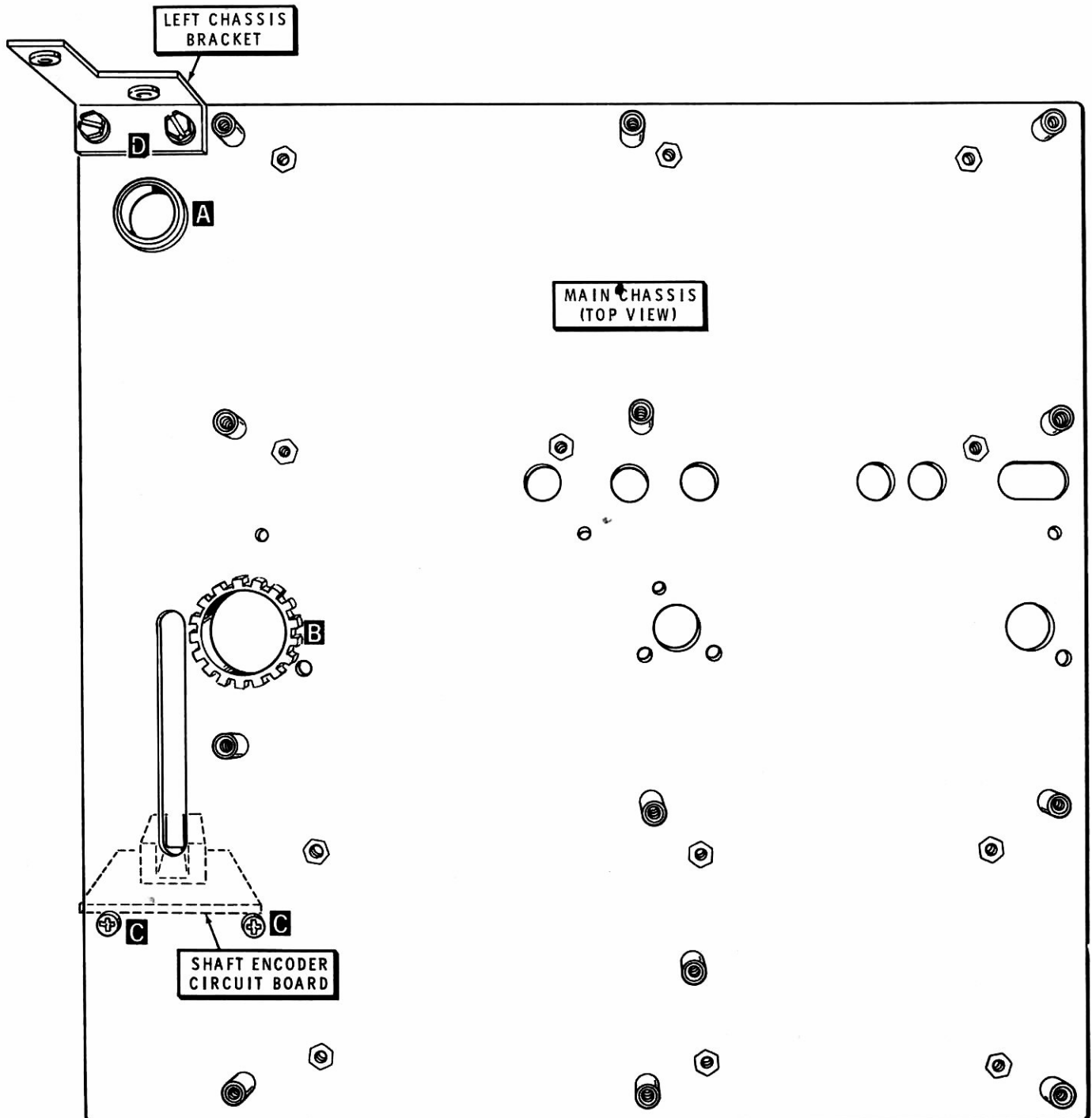

PICTORIAL 15-2

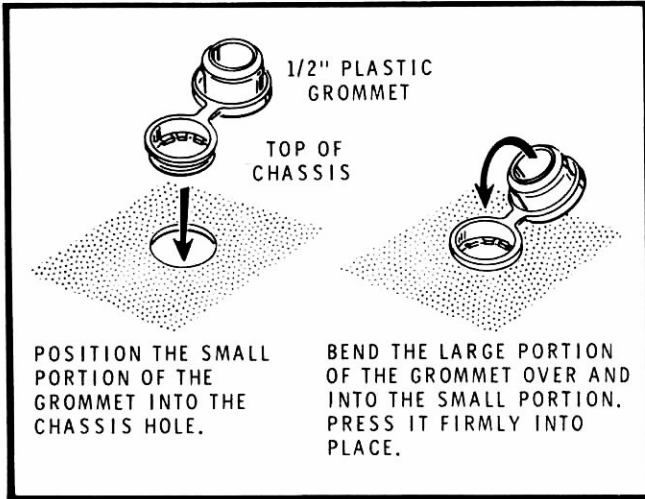

Detail 15-2A

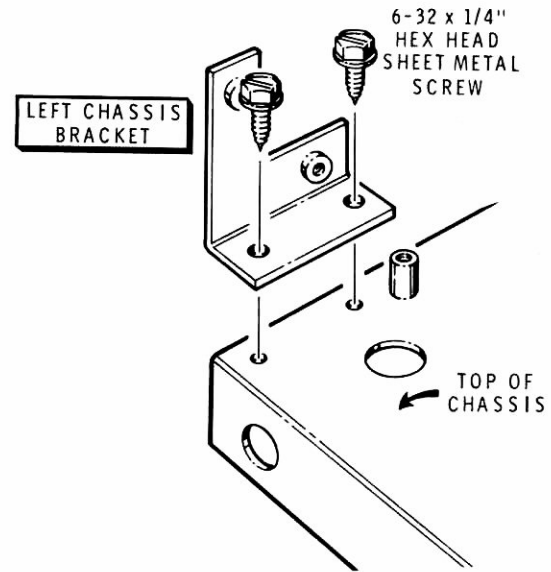

Detail 15-2C

- () Refer to Detail 15-2B Part B and install the 2-5/16" grommet strip in hole B. Start with one end hooked over the edge of the hole and work your way around the hole until it is completely in place.
- () Refer to Detail 15-2C and mount the left chassis bracket onto the chassis at D. Use two #6 x 1/4" hex head sheet metal screws.

- () Refer to Detail 15-2D and mount the shaft encoder circuit board to the bottom of the main chassis at C. Use two 6-32 x 1/4" black phillips head screws. Be sure to mount this circuit board so the slot between the optical couplers lines up with the slot in the main chassis.

Set the main chassis assembly aside temporarily.

PART A

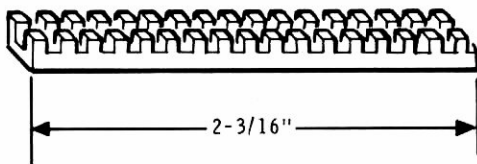

PART B

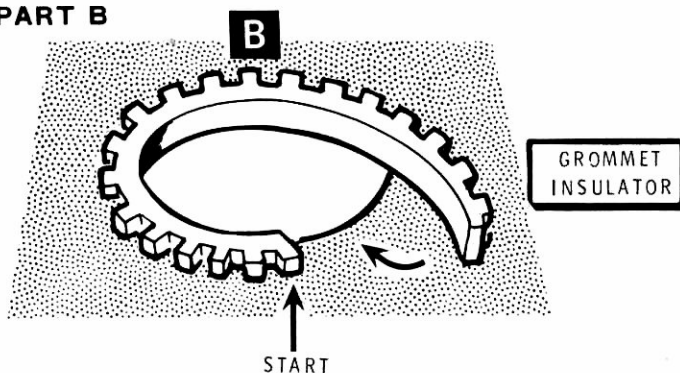

Detail 15-2B

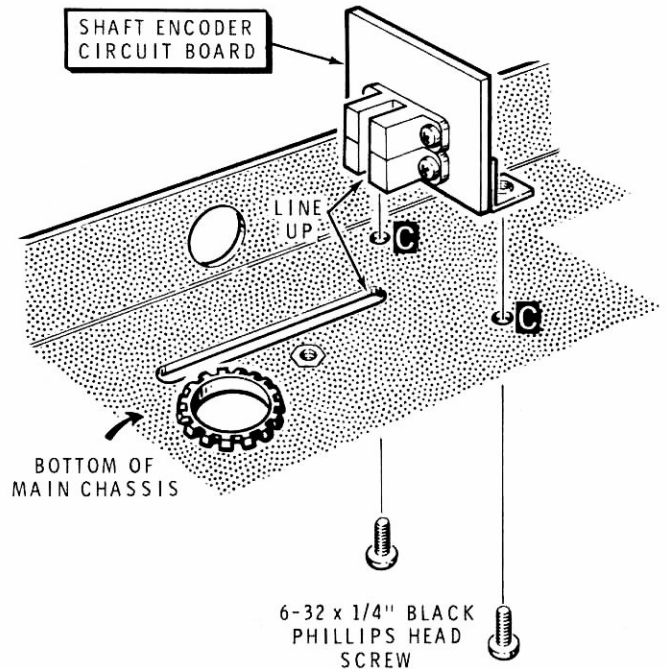

Detail 15-2D

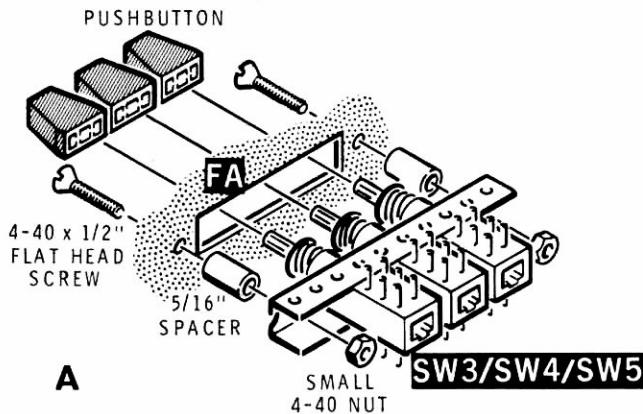

Detail 15-3A

Refer to Pictorial 15-3 (Illustration Booklet, Page 31) for the following steps.

- () Position the front panel as shown in the Pictorial.
- () SW3/SW4/SW5: Refer to Detail 15-3A and mount the 3-section pushbutton switch (locking, #64-898) onto the front panel at FA. Use two 4-40 × 1/2" flat head screws, two 5/16" spacers, and two small 4-40 nuts. Be sure to center the switch in the front panel opening. NOTE: This switch may be mounted either way.
- () SW6/SW7/SW8: Similarly, mount the 3-section pushbutton switch (momentary contact, #64-894) onto the front panel at FB. Use two 4-40 × 1/2" flat head screws, two 5/16" spacers, and two small 4-40 nuts. Be sure to center the switch in the front panel opening. NOTE: This switch may be mounted either way.
- () Refer again to Detail 15-3A and carefully push a pushbutton knob onto the shaft of each pushbutton switch.
- () J2: Refer to Detail 15-3B and use the following procedure to mount the microphone socket onto the front panel at J2:

1. Line up the flat on the socket with the flat in the front panel hole.
2. Insert the indicated side of the connector into the hole in the panel (from the front of the panel).

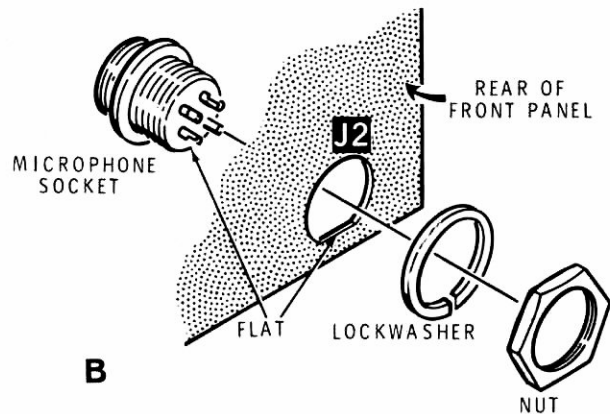

Detail 15-3B

3. Use the hardware supplied with the socket to secure it to the panel.

NOTE: If you **do not** have the Keypad Accessory, perform all of the steps under "Without Keypad Accessory". If you **do** have the Keypad Accessory, perform all of the steps under "With Keypad Accessory".

Without Keypad Accessory

- () Carefully peel the backing paper from the plain label. Then press the label onto the front of the escutcheon as shown in inset drawing #1 on the Pictorial 15-3.
- () Position the door as shown in Detail 15-3C (note the location of the hinge bosses). Then carefully peel the backing paper from the door label. Line up the edges of the door label with the edges of the door; then press the label onto the door.

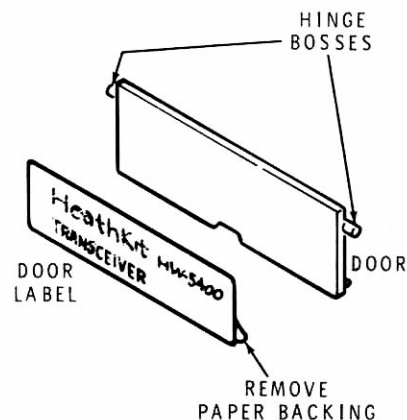

Detail 15-3C

Heathkit[®]

Refer to Detail 15-3D (Illustration Booklet, Page 31) for the following steps.

- () Drop the door into the escutcheon as shown.
- () Place the front panel over the escutcheon.
- () Mount the escutcheon to the front panel with five push-on nuts. Position each push-on nut as shown. NOTE: Use two screwdrivers to push these nuts onto the front panel studs.

Proceed to "Mounting Display Circuit Board".

With Keypad Accessory

- () Position the keypad circuit board with the foil side down and the large hole in the upper right corner as shown in Detail 15-3E.
- () Cut seven 1" lengths of small bare wire (use the wire supplied with the Accessory kit).

NOTE: When you install these wires, keep the board flat against your work surface so the wires cannot protrude through the holes. Solder each wire to the small foil pad as you install it.

- () Refer again to Detail 15-3E and install the bare wires in holes Q through W.
- () Carefully peel the backing from the keypad label. Then press the label onto the front of the escutcheon as shown in inset drawing #2.
- () Position the door as shown in Detail 15-3C (note the location of the hinge bosses). Then carefully peel the backing paper from the door label. Line up the edges of the door label with the edges of the door; then press the label onto the door.

Refer to Detail 15-3D for the following steps.

- () Drop the door into the escutcheon as shown.
- () Place the front panel over the escutcheon.

IMPORTANT: Do not touch the conductive rubber pads on the back of the keypad. Dirt or oil from your fingers can cause the buttons to become intermittent.

- () Refer to the inset drawing and lay the keypad in place so the buttons insert properly into the escutcheon.

- () Refer again to the inset drawing and lay the keypad circuit board on the keypad. Make sure the two bosses on the keypad seat into the two small holes in the board. Fasten the board and keypad with three push-on nuts (supplied with the accessory). Be sure to position the nuts as shown. NOTE: Use long-nose pliers to squeeze the tabs on the nuts together while you install the these nuts.

- () Install the remaining two push-on nuts to fasten the front panel to the escutcheon. Be sure to position these nuts as shown.

NOTE: If you installed the Keypad Accessory, you will have two push-on nuts left-over. These will not be used.

Proceed to "Mounting Display Circuit Board".

Mounting Display Circuit Board

- () M1: Position the meter in its cutout in the escutcheon.

NOTE: When you perform the next step, be careful not to damage the display tube or the lamps that are attached to the display circuit board.

- () Carefully peel away any paper or film that may be on the window. Then drop the window into the indicated cutout in the escutcheon. Then mount the display circuit board onto the front panel. Use five #4 × 1/4" self-tapping screws. Be sure the shafts of the four large controls on the circuit board enter their corresponding holes in the front panel. NOTE: If you have installed the Keypad Accessory, make sure the seven bare wires are inserted into their respective holes in the display circuit board as shown in inset #3. Do not solder these bare wires to the display circuit board yet.

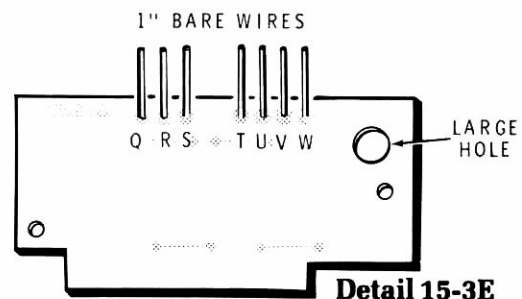

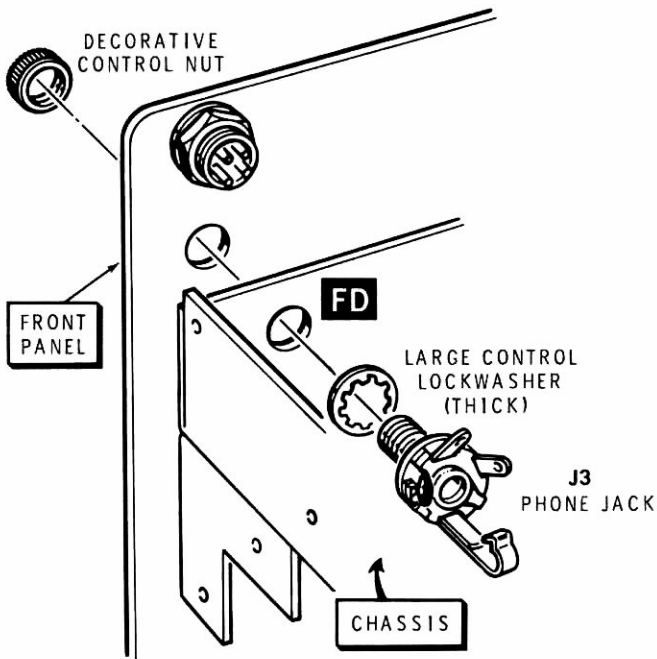

Detail 15-4A

Refer to Pictorial 15-4 (Illustration Booklet, Page 32) for the following steps.

NOTE: When you mount the jack and controls to the front panel, in the following steps, tighten the hardware only finger tight. You will be instructed to tighten the hardware later.

- () **J3:** Position the front panel near the main chassis as shown in the Pictorial. Then refer to Detail 15-4A and mount the phone jack at FD on the front panel and chassis. Use a large control lockwasher (thick) and a decorative control nut. Be sure to position the phone jack as shown in the Pictorial.
- () **SW9:** Refer to Detail 15-4B and mount the 4-position rotary switch (#63-1384) to the front panel and main chassis at FE. Use a large control lockwasher (thick), a large control flat washer, and a large control nut. Be sure to position the switch as shown in the Pictorial.
- () **R4A/R4B:** Refer to Detail 15-4C and mount the dual 10 k Ω /1 k Ω control (#12-181) to the front panel and main chassis at FF. Use a large control solder lug, large control flat washer, and a large control nut. Be sure to position the control and solder lug as shown in the Pictorial.

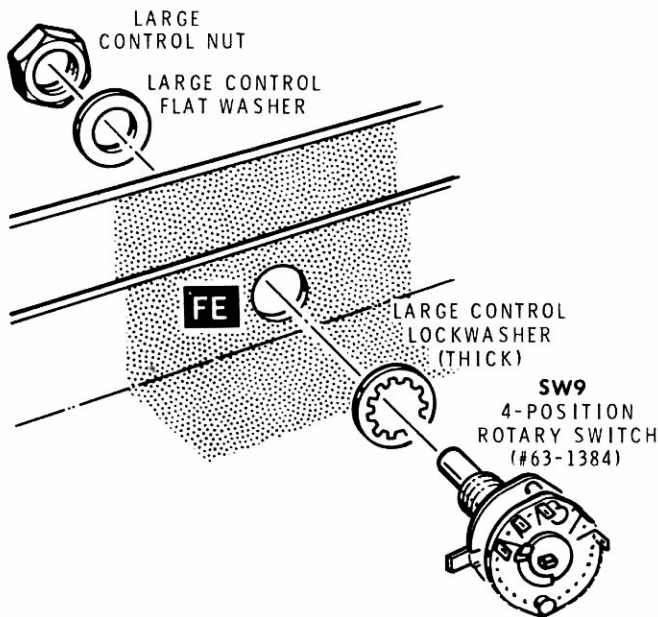

Detail 15-4B

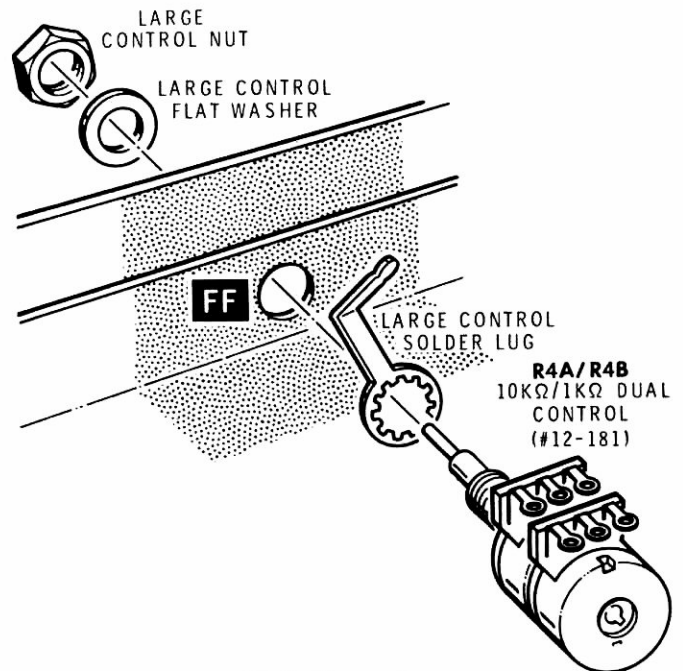

Detail 15-4C

Heathkit®

- () SW3/R2A/R2B: Similarly, mount a dual 1 kΩ/250 kΩ control with switch (#14-22) to the chassis at FG. Use a large control solder lug, a large control flat washer, and a large control nut. Be sure to position the control and the solder lug as shown in the Pictorial.
- () R3A/R3B: Similarly, mount a dual 10 kΩ control with center detent (#12-183) to the front panel and chassis at FH. Use a large control lockwasher (thick) instead of a solder lug, a large control flatwasher, and a large control nut. Be sure to position the control as shown in the Pictorial.
- () Refer to Detail 15-4D and mount the brass bushing to the front panel and main chassis at FJ as shown. Use a large control flat washer, a large control shoulder washer, a large control solder lug, and a large control nut. Be sure to position the solder lug as shown in the Pictorial. Also be sure the shoulder of the shoulder washer enters the hole in the chassis.

- () SW1A: Refer to Detail 15-4E and temporarily mount a 1-wafer, 8-position rotary switch (#63-1385) to the front panel and main chassis at FK. Use a large control lockwasher (thin), a large control flat washer, and a large control nut. Be sure to position the switch as shown in the Pictorial.
- () Tighten all of the hardware that secures the front panel and main chassis together. (Do not tighten the hardware on switch SW1A.)

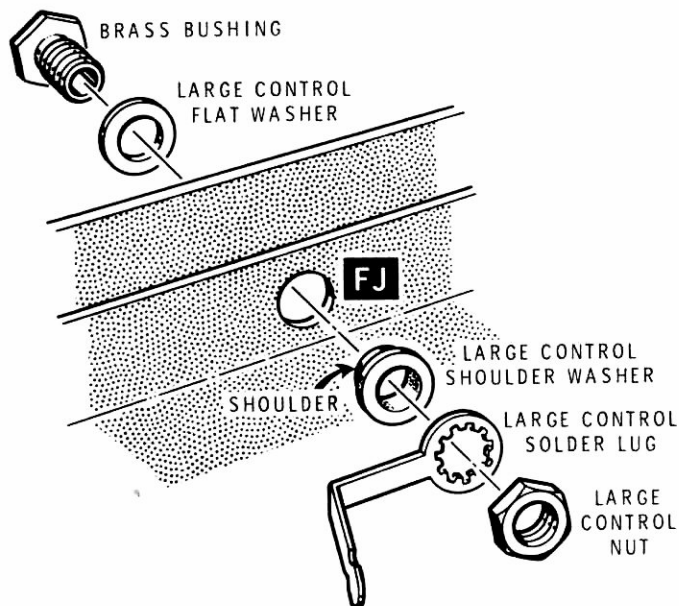

Detail 15-4D

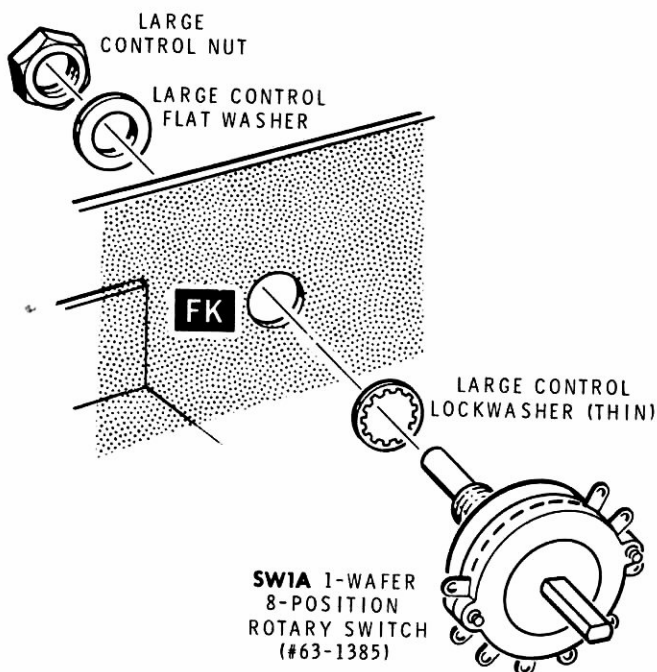

Detail 15-4E

- () Refer to Detail 15-4F Part 1 and snap an E-ring onto the slotted end of the 1-7/8" shaft.
- () Open the grease container (#352-14) and apply a thin layer of the grease onto the 1-7/8" shaft. NOTE: Do not use the thermal compound for this. After you complete this step, set the grease aside so you do not use it when thermal compound is called for.

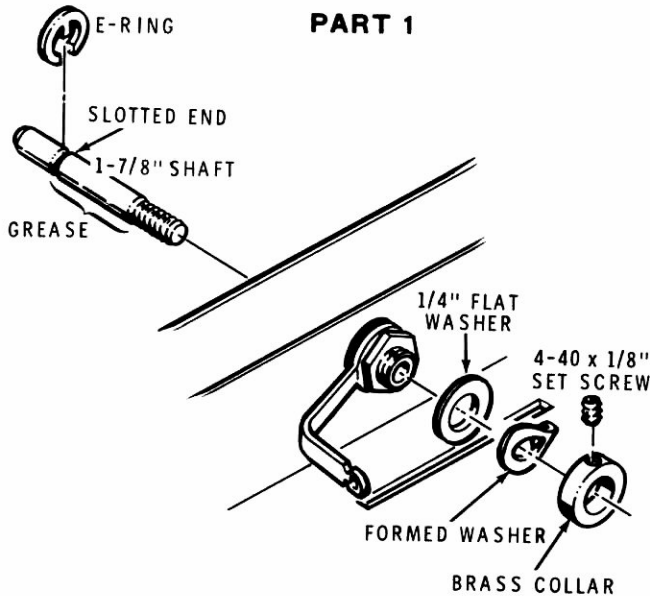

- () Insert the threaded end of the 1-7/8" shaft into front panel bushing FJ. Push the shaft through the bushing until the E-ring is against the bushing (on the front panel).
- () Use a small allen wrench to start a 4-40 x 1/8" setscrew into the brass collar.
- () Apply a thin layer of grease (#352-14) to a 1/4" flat washer and the brass collar. Then slide the 1/4" flat washer, a formed washer, and the brass collar over the threaded end of the shaft. Position the formed washer as shown. Do not tighten the setscrew yet.
- () Use the small allen wrench to start a 4-40 x 1/8" setscrew into the brass collar.
- () Slide a 1/4" flat washer, a formed washer, and the brass collar over the threaded end of the shaft. Position the formed washer as shown. Do not tighten the setscrew yet.
- () Refer to Part 2 of the Detail 15-4F and turn a small control nut about 2/3 of the way onto the threaded portion of the shaft. Then place a 1/4" flat washer onto the threaded end of the shaft so it is against the nut.

NOTE: To accomplish the next step, you may have to adjust the small control nut on the shaft. This will allow you to slide the disc onto the shaft.

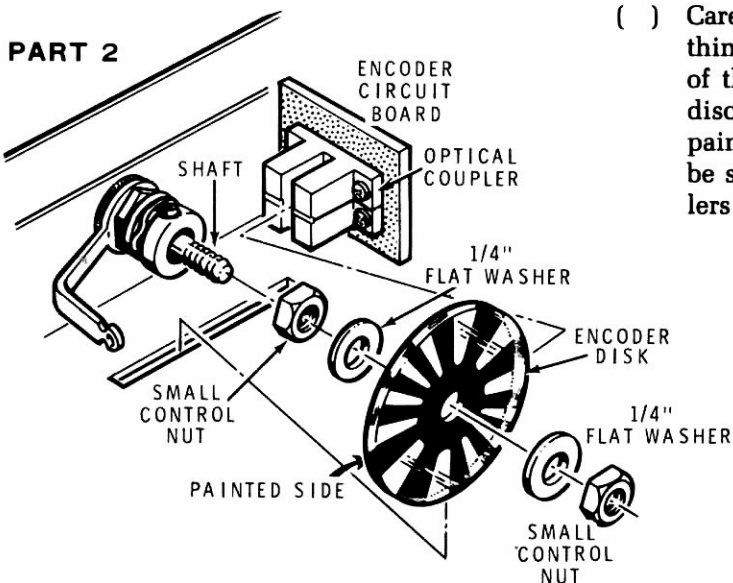

Detail 15-4F

- () Carefully peel away any backing paper and thin film that may be on either, or both, sides of the encoder disc. Then place the encoder disc onto the threaded end of the shaft so the painted side is toward the front panel. Also be sure the disc is between the optical couplers on the shaft encoder circuit board.

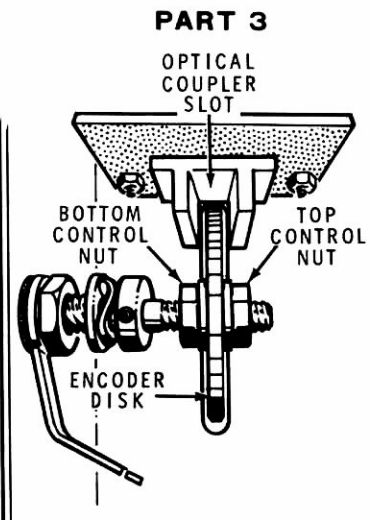

Heathkit®

- () Place another 1/4" flat washer onto the threaded end of the shaft. Then start another small control nut onto the shaft. Do not tighten this nut yet.
- () Push the shaft into the bushing so the E-ring is against the escutcheon. Then push the brass collar against the formed washer to compress the washer slightly and tighten the brass collar setscrew. Use a small allen wrench.
- () Refer to Part 3 of the Detail 15-4F and center the encoder disc in the optical coupler slots by raising the bottom control nut. When you have the disc centered in the slots, tighten the top control nut firmly against the disc.
- () Position the rear chassis near the main chassis as shown in Detail 15-4G (note the locations of the two larger holes near one side of the rear chassis). Then secure the rear chassis to the main chassis with five #6 × 1/4" hex head sheet metal screws.
- () Install a 3/8" plastic grommet in rear chassis hole RE and a 1/2" plastic grommet in hole RF.

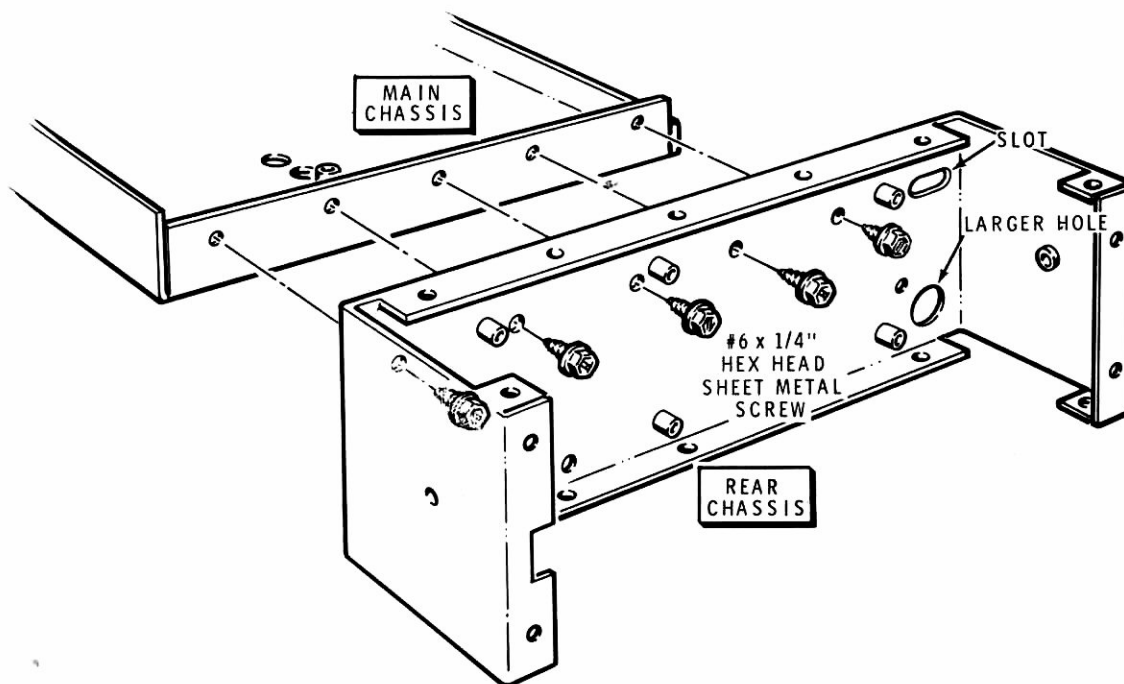

Detail 15-4G

Refer to Pictorial 15-5 (Illustration Booklet, Page 33) for the following steps.

- () Reposition the chassis assembly right-side-up as shown in the Pictorial.
- () Mount the center shield to the chassis assembly as shown. Use four #6 × 1/4" hex head sheet metal screws.

- () Refer to Detail 15-5A and mount the high VCO assembly on the bottom of the main chassis as shown. Use one #6 × 3/8" hex head screw in the mounting hole that is toward the front panel. Be sure the other mounting location on the assembly lines up with its hole in the chassis before you tighten the screw. Also be sure you have the VCO positioned so the four feedthrough capacitors are toward the correct side of the chassis.

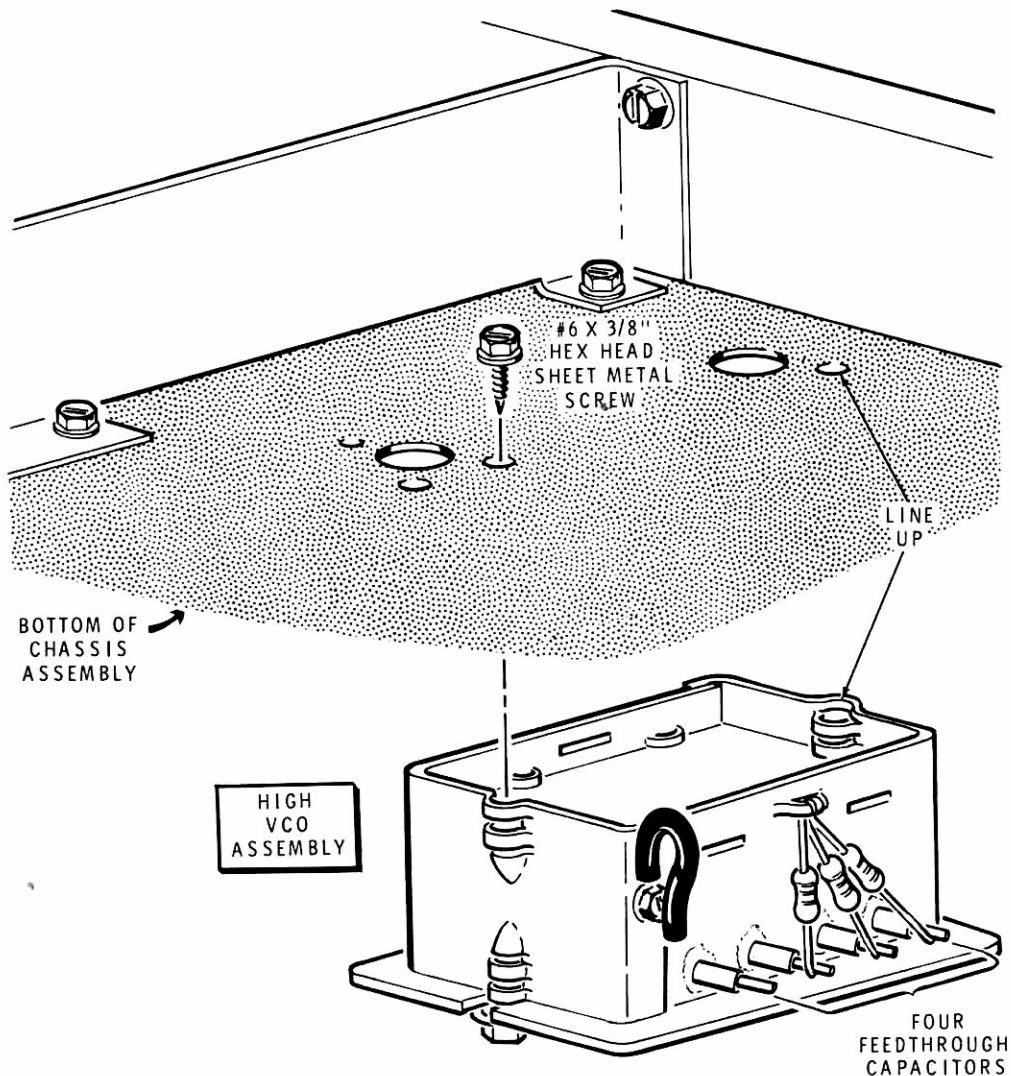

Detail 15-5A

Heathkit®

- () Refer to Detail 15-5B and mount the inverter assembly to the top of the main chassis as shown. Use two #6 × 3/8" hex head sheet metal screws. Be sure the rear mounting screw also secures the rear of the high VCO assembly.

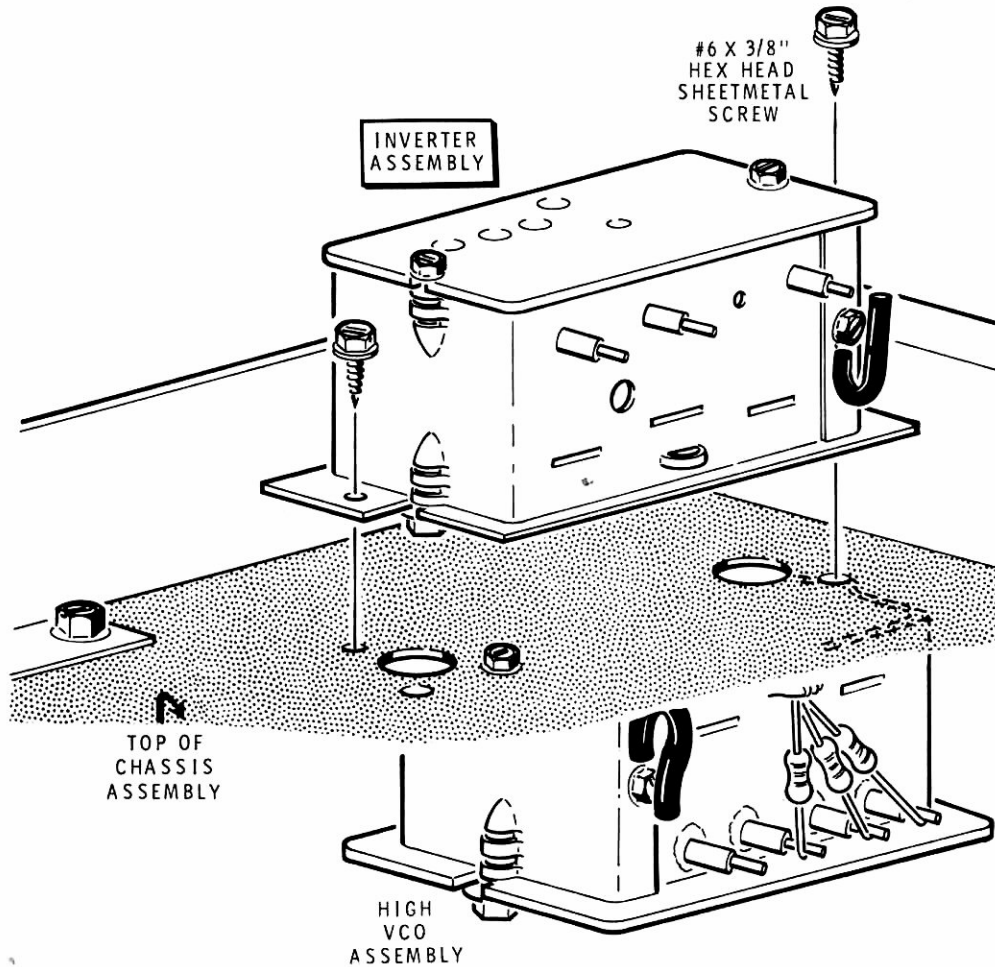
**Detail 15-5B**

- () Refer to Detail 15-5C and mount the low VCO assembly onto the bottom of the main chassis as shown. Use two #6 × 3/8" hex head sheet metal screws and two long #6 solder lugs. Be sure to position the VCO assembly so the three feedthrough capacitors are toward the correct side of the chassis. Also be sure to position the sol-

der lugs as shown in the Pictorial before you tighten the screws.

- () Cut two 1-1/2" lengths of medium heat-shrink sleeving. Then slide a length of this sleeving onto each of the long #6 solder lugs.

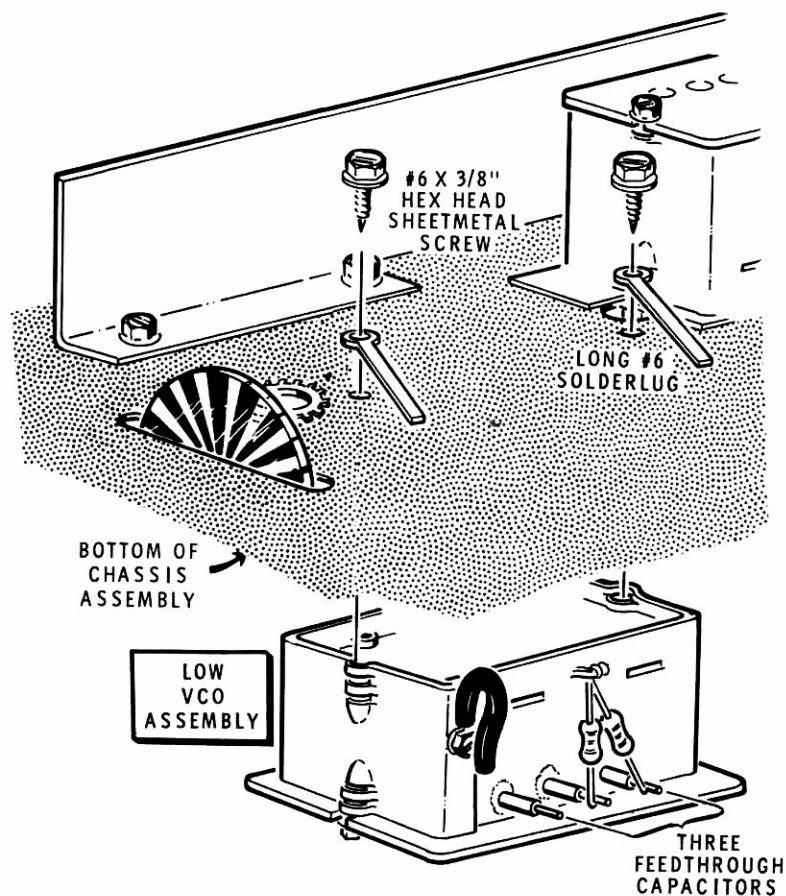

Detail 15-5C

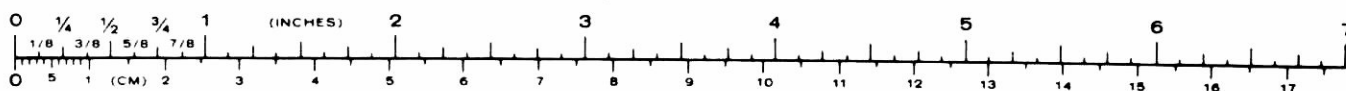

Heathkit®

Refer to Pictorial 15-6 (Illustration Booklet, Page 33) for the following steps.

- () Position the main chassis upside-down as shown in the Pictorial.

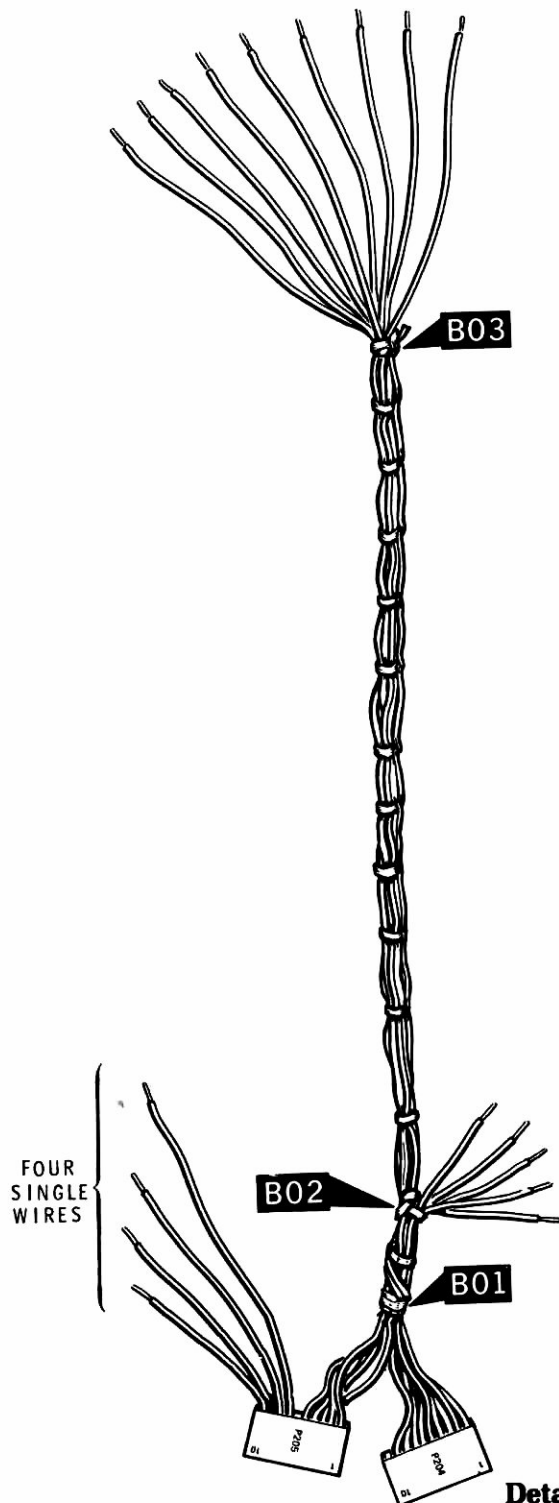

Detail 15-6A

- () Unfold the front panel wire harness (#134-1189) as shown in Detail 15-6A. Refer to the wire colors at each breakout (where a group of wires come from the harness) to make sure you have the harness positioned properly.
- () Label the connector on this wire harness that has the four single wires coming from it "P205" and label the other connector "P204". NOTE: Install these labels so the hole numbers are away from the wire side of the socket.
- () Push harness breakouts 2 and 3 up through grommet A in the chassis. Then route the harness along the front panel as shown.
- () Bend the lugs on switch SW1A toward the back of the switch as shown in the Pictorial.

NOTE: When you connect the harness wires to switch SW1A in the following steps, you may wish to loosen the hardware and rotate the switch a small amount to gain access to some of the lugs.

Connect the wires from harness breakout #3 to switch SW1A as follows:

- () Black wire to lug 1 (S-1).
- () Brown wire to lug 2 (S-1).
- () Red wire to lug 3 (S-1).
- () Orange wire to lug 4 (S-1).
- () Yellow wire to lug 5 (S-1).
- () Green wire to lug 6 (S-1).
- () Blue wire to lug 7 (S-1).
- () Violet wire to lug 8 (S-1).
- () Gray wire to lug 9 (S-1).

- () Use pliers to turn the shaft of switch SW1A fully counterclockwise.
- () Remove the hardware from switch SW1A. Then refer to Detail 15-6B and remount the switch with the right chassis bracket as shown. Be sure to position the switch and the bracket as shown in the Pictorial.
- () Inspect the lugs of switch SW1A to make sure they are not touching the nearby control or the right chassis bracket. If any lug is touching, carefully bend it away as necessary.
- Connect the wires from harness breakout #2 to switch SW9 as follows:
- () Black wire to lug 1 (S-1).
- () Red wire to lug 2 (S-1).
- () Brown wire to lug 3 (S-1).
- () Yellow wire to lug 4 (S-1).
- () Orange wire to lug 5 (S-1).

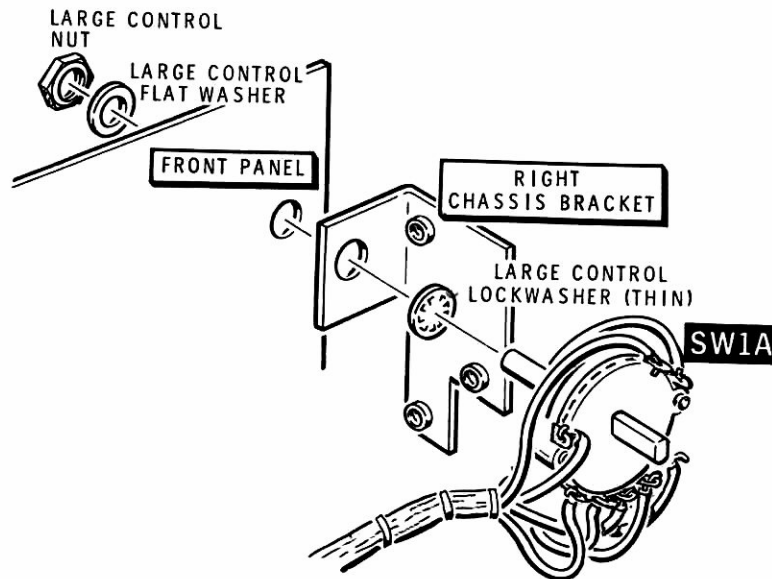

Detail 15-6B

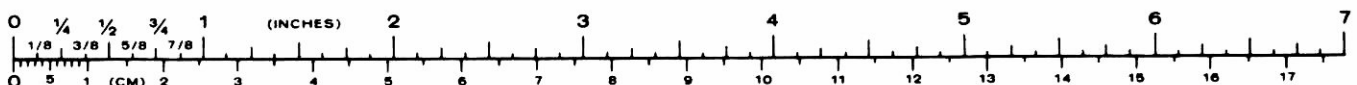

Heathkit®

Refer to Pictorial 15-7 (Illustration Booklet, Page 34) for the following steps.

- () Position the main chassis as shown in the Pictorial.

NOTE: When you connect wires to the pushbutton switches, use only enough heat to ensure a good solder connection.

- () Cut a 1-1/2" small bare wire. Then connect the wire from switch SW6 lug 2 (S-1) to switch SW8 lug 5 (NS). Be sure to position the wire against switch SW6 lug 5, switch SW7 lugs 2 and 5, and switch SW8 lug 2 as shown. Then solder the wire to these lugs.

Connect the wires coming from the 10-pin socket at breakout #1 of the front panel wire harness as follows:

- () Yellow wire to switch SW6 lug 6 (S-1).
- () Orange wire to switch SW7 lug 3 (S-1).
- () Red wire to switch SW8 lug 3 (S-1).
- () Brown wire to switch SW8 lug 5 (S-2).
- () Refer to the inset drawing and push sockets P205 and P204, coming from grommet A, onto display circuit board plugs P205 and P204. Be sure the black wires in these sockets are at plug pins 1.
- () Remove any shorting wire that may be connected between the lugs of meter M1. Then bend the lugs so they are perpendicular to the back of the meter as shown.
- () Connect the red wire coming from hole plus (+) of the display circuit board to the positive (+) or dot marked lug of meter M1 (S-1).
- () Connect the brown wire coming from hole minus (-) of the display circuit board to the negative (-) or unmarked lug of meter M1 (S-1).
- () Unfold the main wire harness (#134-1190) as shown in Detail 15-7A (Illustration Booklet, Page 35). Refer to the wire colors at each breakout to be sure you have the harness positioned properly. Then wrap a piece of tape (not supplied) around the harness between breakouts #5 and #12. NOTE: You will use this piece of tape for reference in the next step.

- () Refer again to Detail 15-7A and label each of the connectors on the main wire harness as shown. Be sure you install these labels on the smooth (not slotted) side of the connector so the numbers are toward the wires.

- () Carefully push breakouts #12 through #25 (all of the breakouts on one side of the tape) down through chassis grommet B.

- () Route main harness breakouts #1 through #4 as shown. Then secure this part of the harness in place with the three long #6 solder lugs indicated.

NOTE: When you route some of the main harness breakouts, in the following steps, you may wish to temporarily tape the harness to the chassis to hold it in place.

- () Route main harness breakouts #8 through #11 across the front of the chassis as shown.
- () Route main harness breakouts #6 and #7 around the center shield as shown.
- () Connect the red wire coming from the 10-pin socket at main harness breakout #1 to feedthrough capacitor C513 (NS) on the inverter assembly.
- () Connect the red wire from main harness breakout #1 to feedthrough capacitor C513 (S-3) on the inverter assembly.

Connect the wires coming from main harness breakout #2 to the inverter assembly as follows:

- () Both orange wires to feedthrough capacitor C515 (S-2).
- () Blue wire to feedthrough capacitor C514 (S-1).
- () Install a small spring connector on the green wire coming from breakout #3 of the main harness. NOTE: You will insert this connector in a socket shell later.
- () Prepare a 4" small green stranded wire. Then install a circuit board connector on one end of this wire. Use the same procedure as you did earlier and be sure to shrink a 5/8" length of heat-shrink sleeving onto the connector.

- () Push the connector on the end of the prepared green wire onto pin C on the display circuit board. Then route the free end of this wire down through main chassis grommet B as shown. The free end of this wire will be connected later.
- () Cut a 1-5/8" small bare wire. Then connect one end of the wire to switch SW3 lug 1 (S-1). Route the wire as shown and connect the free end of the wire to switch SW5 lug 6 (NS). Now solder the bare wire to switch SW4 lugs 3 and 6, and switch SW5 lug 3.
- () Connect the black wire coming from the 10-pin socket at main harness breakout #8 to switch SW5 pin 6 (S-2).

Connect the wires coming from main harness breakout #9 as follows:

- () White-black wire to switch SW3 lug 2 (S-1).
- () Yellow wire to switch SW3 lug 3 (S-1).
- () Brown wire to switch SW4 lug 5 (S-1).
- () Both white-brown wires to SW5 lug 5 (S-2).
- () Push socket P201, coming from main harness breakout #8, onto Plug P201 on display circuit board. Be sure the slotted side of the socket is down (label side up). Disregard any pin numbers printed on the circuit board.
- () Install circuit board connectors and 5/8" lengths of heat-shrink sleeving on the following wires at main harness breakout #6:

Green

White-black

White-gray

White-green

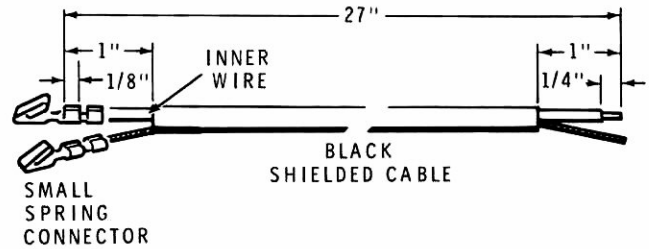

Detail 15-7B

- () Install a small spring connector on the white-orange wire coming from main harness breakout #6.
- () Locate socket P703 coming from the display circuit board. Then push the spring connector on the white-orange wire coming from main harness breakout #6 into hole 1 of this socket.
- () Install a circuit board connector on the green wire coming from main harness breakout #7. Shrink a 5/8" length of medium heat-shrink sleeving onto this connector.
- () Refer to Detail 15-7B and prepare a 27" black shielded cable as shown.
- () Install small spring connectors on the inner and the shield wires at one end of the prepared shielded cable. Do not shorten the shield wires.

Push the spring connectors on the end of the shielded cable into socket P701 coming from main harness breakout #7 as follows.

- () Shield wires into hole 1.
- () Inner wire into hole 4.
- () Push the free end of the shielded cable down through main chassis grommet B. The free end of this cable will be connected later. Leave about 5" of the cable on top of the main chassis.



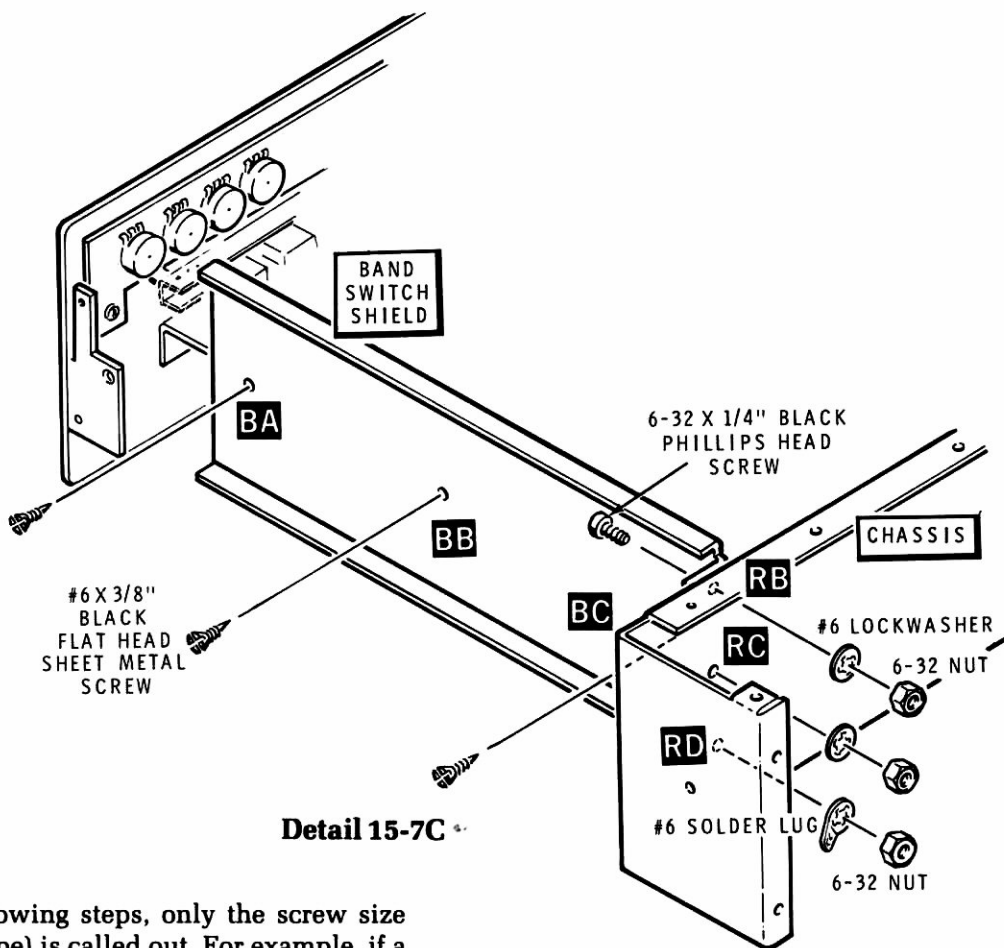

Detail 15-7C

NOTE: In the following steps, only the screw size (and sometimes type) is called out. For example, if a step calls for "6-32 \times 3/8" hardware", it means you should use a 6-32 \times 3/8" screw, one or more lockwashers, and a 6-32 nut. The Pictorial or Detail referred to in the step shows the proper number and use of the lockwashers.

- () Refer to Detail 15-7C and mount the bandswitch shield onto the right side of the chassis as shown. Use three #6 \times 3/8" flat head sheet metal screws at BA, BB, and BC. Use 6-32 \times 1/4" black phillips head hardware at RB and RC and 6-32 \times 1/4" black phillips head hardware and a #6 solder lug at RD. Be sure to position the solder lug as shown.
- () Fold a 1-7/8" \times 5-1/2" insulator paper 2" from one end as shown in Detail 15-7D. Then carefully peel the backing paper from the insulator and press the insulator on the inside of the rear chassis and bandswitch shield as shown in the Pictorial.

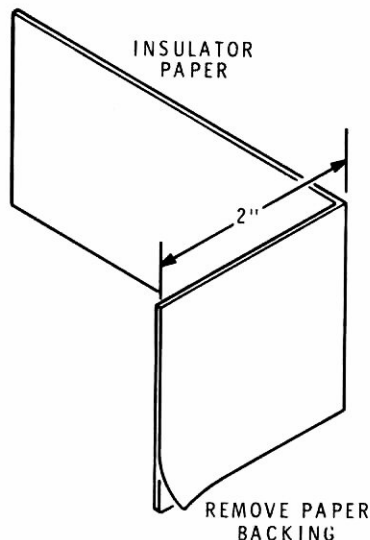

Detail 15-7D

() U906: Refer to Detail 15-7E and use the following procedure to mount an LM383 integrated circuit (#442-713) onto the bandswitch shield at U906:

1. Turn a 6-32 \times 3/4" threaded stud into the boss at U906 so it extends an equal amount from each end of the boss.
2. Straighten the leads of the integrated circuit.
3. Apply a small amount of thermal compound (set aside earlier) to the flat side of the integrated circuit.
4. Mount the integrated circuit to the threaded stud with a #6 lockwasher and a 6-32 nut. Be sure the stud stays centered in the bandswitch shield boss.

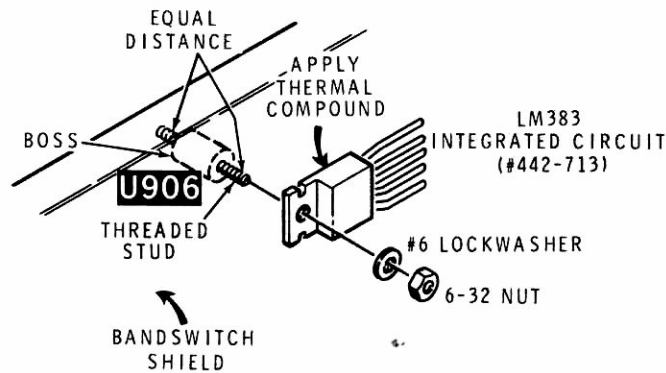

Detail 15-7E

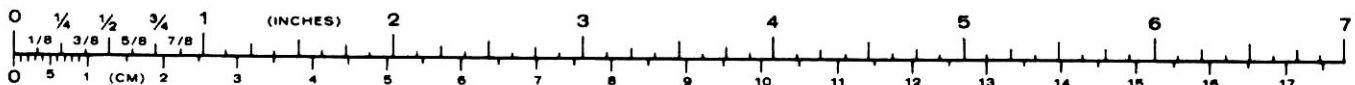

Heathkit®

Refer to Pictorial 15-8 (Illustration Booklet, Page 36) for the following steps.

- () Position the chassis upside-down as shown in the Pictorial.
- () Route main harness breakouts #13 and #14 across the front of the chassis as shown in the Pictorial.
- () Install circuit board connectors and 5/8" lengths of heat-shrink sleeving on the following wires coming from main harness breakout #13:

White-red

Orange

White-brown

Connect the remaining wires coming from main harness breakout #13 to control R4A as follows:

- () All three white-gray wires to lug 1 (NS).
- () Brown wire to lug 2 (NS).
- () C5: Connect a .05 μ F ceramic capacitor from control R4A lug 2 (S-2) to the nearby control solder lug (NS).
- () C6: Connect a .05 μ F ceramic capacitor from control R4A lug 1 (S-4) to the nearby control solder lug (NS).
- () Cut a 2-1/4" small bare wire and a 5/8" length of small black sleeving. Use this wire and sleeving in the next step.

NOTE: When a wire passes through or goes around a lug and continues on to a third lug, the solder step will count this as two wires; one entering and one leaving the connection.

- () Connect one end of the 2-1/4" bare wire to control R4A lug 3 (S-1). Slide the 5/8" length of sleeving onto the free end of the wire. Then connect the wire around the nearby solder lug (S-4) to control R4B lug 1 (NS).

- () Install circuit board connectors and 5/8" lengths of medium heat-shrinkable sleeving on the following wires coming from main harness breakout #14:

White-green

White-blue

White-gray

- () Refer to the inset drawing on the Pictorial and connect the green wire coming from main harness breakout #14 to microphone socket J2 lug 3 (S-1).

- () R5: Connect a 47 Ω , 1/2-watt (yellow-violet-black) resistor between phone jack J3 lugs 1 (NS) and 3 (NS).

- () Cut a 3/4" small bare wire. Then connect the wire between microphone socket J2 lugs 2 (NS) and 4 (S-1).

- () Route main harness breakouts 21 through 25 and the shielded cable, coming from main chassis grommet B, across the center of the main chassis as shown. Push breakouts 24 and 25 through rear chassis grommet RF. Also push the free end of the shielded cable through grommet RF. Then use the long #6 solder lugs indicated to secure the shielded cable and this part of the harness in place.

Connect the wires coming from main harness breakout #21 to the low VCO as follows:

- () White-brown wire to feedthrough capacitor C314 (S-1).

- () Green wire to feedthrough capacitor C317 (S-2).

- () Yellow wire to feedthrough capacitor C316 (S-2).

- () Connect the wires coming from main harness breakout #23 to the high VCO as follows:

- () White-gray wire to feedthrough capacitor C367 (S-1).

- () Black wire to feedthrough capacitor C372 (S-2).
- () White wire to feedthrough capacitor C371 (S-2).
- () White-yellow wire to feedthrough capacitor C369 (S-2).
- () Connect the free end of the green wire coming from main chassis grommet B to control solder lug FJ (S-1) on the front panel. Be careful not to burn the encoder disc with your soldering iron.
- () Route main harness breakouts 16 through 20 across the front of the main chassis as shown.

Connect the wires coming from main harness breakout #16 as follows:

- () White-gray wire to shaft encoder circuit board hole $\phi 2$ (S-1).
- () White-green wire to shaft encoder circuit board hole $\phi 1$ (S-1).
- () White-orange wire to shaft encoder circuit board hole +5 (S-1).
- () Both white-red wires to control R2A lug 1 (NS).
- () White-yellow wire to control R2A lug 2 (S-1).
- () Black wire to switch SW3 lug 1 (S-1).
- () C4: Connect a .05 μ F ceramic capacitor from control R2A lug 1 (S-3) to the nearby control solder lug (NS).
- () Cut a 2-1/4" small bare wire and a 5/8" length of black sleeving. Use this wire and sleeving in the next step.

- () Connect one end of the 2-1/4" bare wire to control R2A lug 3 (NS). Slide the 5/8" length of sleeving onto the free end of the wire. Then connect the wire around the nearby control solder lug (NS) to control R2B lug 1 (NS).
- () Prepare a 2" and a 2-1/2" white solid wire. Use these wires in the following steps.
- () Connect the 2" white solid wire from control R2A lug 3 (S-2) to switch SW3 lug 2 (S-1).
- () Connect the 2-1/2" white solid wire from the control solder lug on control R2A (S-4) to control R3A lug 1 (S-1).

Connect the wires coming from main harness breakout #17 as follows:

- () White-blue wire to control R3A lug 2 (S-1).
- () Both violet wires to control R3A lug 3 (S-2).
- () Green wire to control R3B lug 1 (NS).
- () Both orange wires to control R3B lug 3 (NS).
- () Locate the 2-1/2" 3-wire cable (brown, red, and orange wires) set aside earlier. Then refer to Detail 15-8A and prepare this cable group as shown.

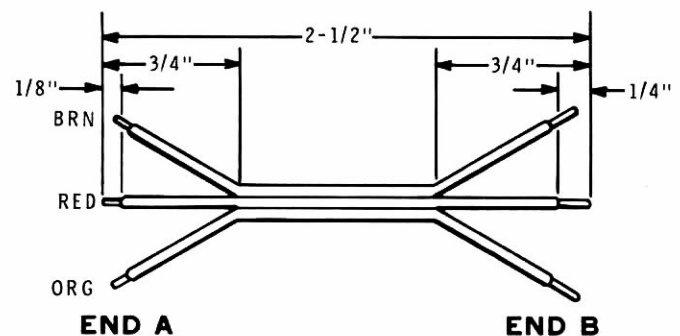

Detail 15-8A

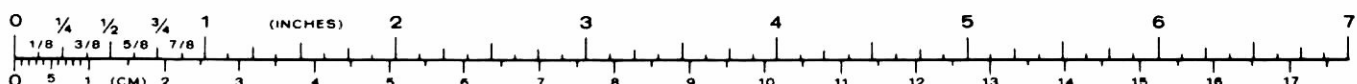

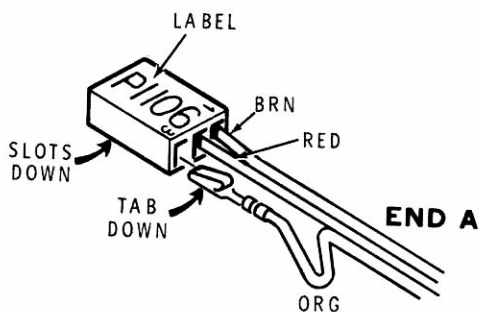

Detail 15-8B

- () Install small spring connectors on End A of the prepared 3-wire cable. Then refer to Detail 15-8B and insert the connectors on the end of this cable into a 3-pin socket shell as follows. Be sure to push each spring connector until it locks into place.

Brown wire into hole 1.

Red wire into hole 2.

Orange wire into hole 3.

- () Label this connector "P1106".

Connect the free end of the 3-wire cable to control R3B as follows:

- () Brown wire to lug 3 (S-3).
- () Red wire to lug 2 (S-1).
- () Orange wire to lug 1 (S-2).
- () Prepare two 5" black shielded cables as shown in Detail 15-8C.
- () Connect the inner lead at one end of a prepared shielded cable to feedthrough capacitor C315 on the low VCO assembly (S-1). Solder the shield wires on this end of the shielded cable to the side of the low VCO assembly in the area shown.
- () Connect the inner lead at the free end of the shielded cable coming from the low VCO assembly to feedthrough capacitor C368 on the high VCO assembly (NS). Solder the shield wires on this end of the shielded cable to the side of the high VCO assembly in the area shown.
- () Connect the inner lead at one end of the remaining prepared 5" shielded cable to the feedthrough insulator on the low VCO assembly (NS). Solder the shield wires on this end of the shielded cable to the side of the low VCO assembly in the area shown.
- () Connect the inner lead at the free end of the shielded cable coming from the low VCO assembly to the feedthrough insulator on the high VCO assembly (S-1). Solder the shield wires on this end of the shielded cable to the side of the high VCO assembly in the area shown.

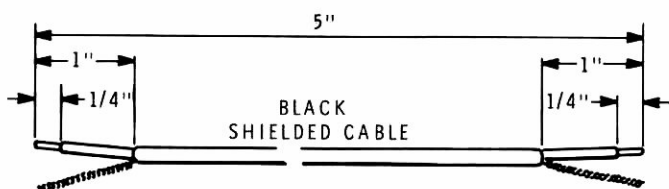

Detail 15-8C

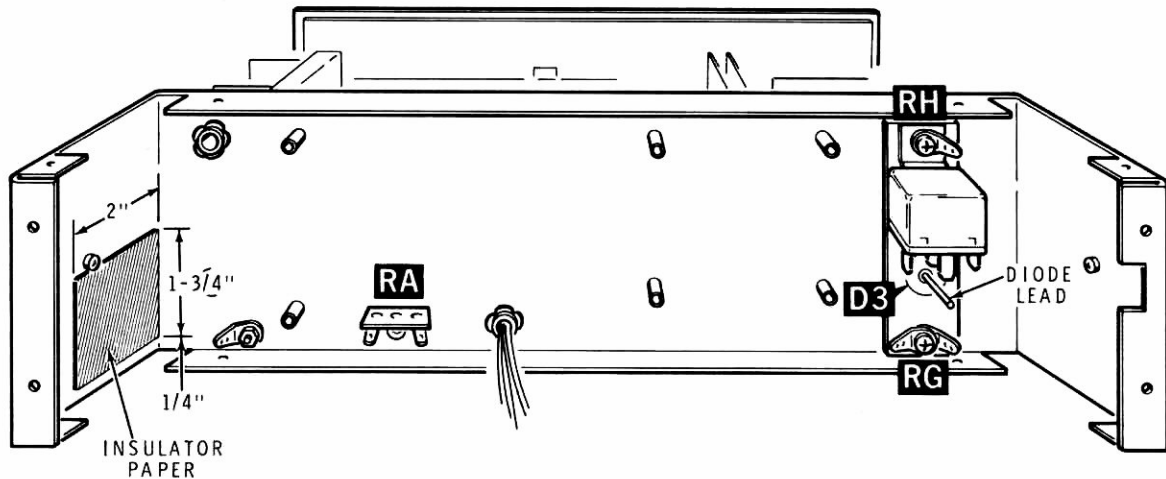

PICTORIAL 15-9

Refer to Pictorial 15-9 for the following steps.

- () Position the main chassis as shown in the Pictorial.
- () Carefully peel the backing paper from a 1-3/4" × 2" insulator paper. Then press the insulator onto the inside of the rear chassis in the area shown.
- () Refer to Detail 15-9A and mount a 2-lug terminal strip on the rear chassis at RA. Use 6-32 × 1/4" black phillips head hardware. Be sure to position the terminal strip as shown in the Pictorial.
- () D3: Position the raised portion of a 1N3491 diode (#57-35) in the larger hole in the relay mounting bracket as shown in Detail 15-9B. Then secure the mounting bracket to the rear chassis at RG. Use a 6-32 × 5/8" black phillips head screw, a 7/32" × 5/16" spacer, and two #6 solder lugs. Be sure to position the solder lugs as shown in the Pictorial. Also be sure to align the other hole in the mounting bracket with mounting hole RH in the rear chassis.

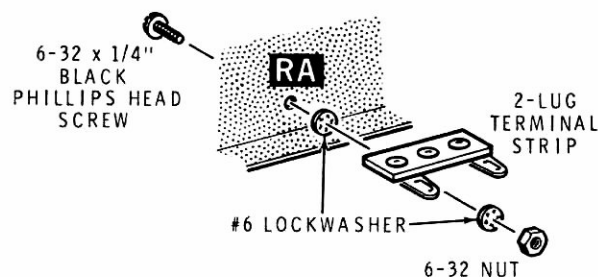

Detail 15-9A

Heathkit®

() K1: Refer again to Detail 15-9B and mount the relay (#69-90) and the relay mounting bracket to the rear chassis at RH. Use a 6-32 x 5/8" black phillips head screw, a 7/32" x 5/16" spacer, and

a #6 solder lug. Be sure to position the solder lug and the relay as shown in the Pictorial. Also be sure diode D3 stays centered in the larger hole of the mounting bracket.

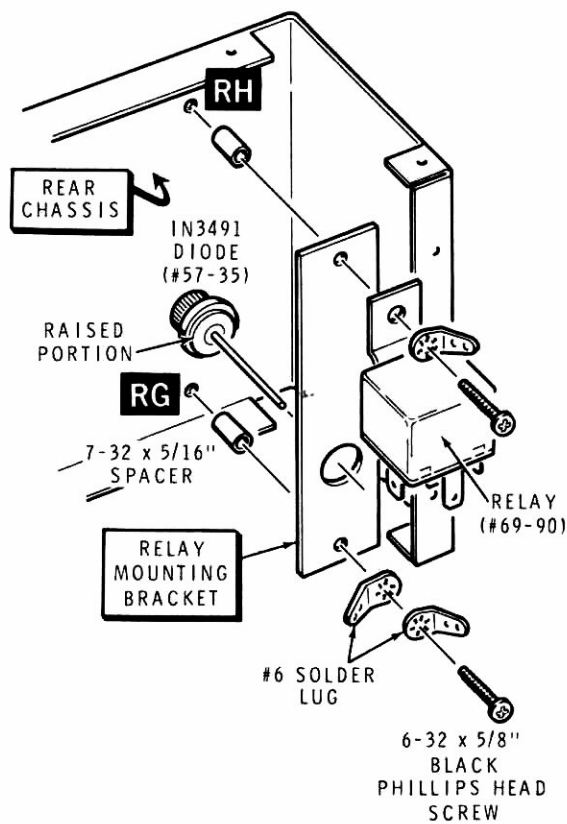

Detail 15-9B

Refer to Pictorial 15-10 (Illustration Booklet, Page 37) for the following steps.

- () C7: Cut both leads of a .05 μ F ceramic capacitor to 1/2". Then connect the capacitor between the eyelet of terminal strip RA lug 1 (S-1) and the center eyelet (NS). Cut off any excess lead lengths.
- () C8: Cut both leads of a .05 μ F ceramic capacitor to 1/2". Then connect this capacitor between the center eyelet (S-2) and the eyelet at lug 2 (S-1) of terminal strip RA. Cut off any excess lead lengths.
- () Connect both white-black wires coming from main harness breakout #24 to terminal strip RA lug 2 (NS).
- () Locate the white-gray wire in the main harness near breakout #24. Then cut this wire as close to grommet RF as possible. NOTE: The part of the wire that goes through grommet RF will not be used.
- () Pull the white-gray wire (that you cut above) out of one or two of the harness laces so you can connect it to terminal strip RA. Then prepare the end of the wire.
- () Connect the free end of the prepared white-gray wire, coming from the main harness, to terminal strip RA lug 2 (NS).
- () L1: Cut both leads of a hash filter choke (#45-98) to 5/8". Then connect the choke between terminal strip RA lugs 1 (NS) and 2 (NS). Position the choke under the terminal strip as shown.
- () Prepare a 9-1/4" medium white stranded wire. Then route the wire under choke L1 and connect the wire from the bottom hole in solder lug RD (S-1) to the bottom hole in the indicated solder lug at RH (S-1). NOTE: You will connect a wire to the top hole in solder lug RH later.
- () Prepare a 9" large red stranded wire. Then refer to Detail 15-10A and install a push-on connector on one end of this wire.

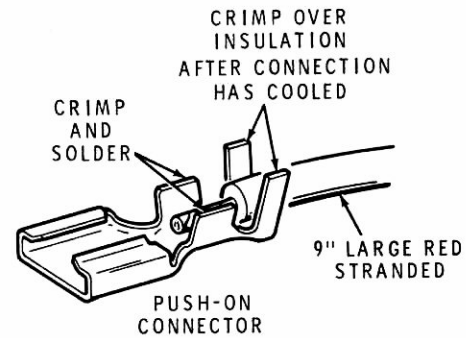

Detail 15-10A

- () Push the connector on the end of the prepared red wire onto relay K1 lug 30 (see inset drawing #1 on the Pictorial for the lug numbering). Then route the free end of this wire under capacitors C7 and C8 and connect it to terminal strip RA lug 1 (NS).
 - () Cut a 1" large bare wire. Then form this wire into a loop as shown in the inset drawing #2 on the Pictorial.
- NOTE: In the following steps, the solder information does not count wires or leads that were previously soldered in a different hole or eyelet of a lug.
- () Connect the free end of the large bare wire to terminal strip RA lug 1 (S-3). Position this wire so the loop is near the terminal strip lug; but do not fill the loop with solder. Be sure the lead that was previously soldered in the eyelet of this lug remains well soldered.
 - () C3: Cut the lead at the negative (-) end of a 2200 μ F electrolytic capacitor to 1" and the lead at the positive (+) end to 1-1/4". Then position this capacitor beside relay K1 as shown in the Pictorial. Connect the negative lead to solder lug RG (S-1). Slide a 1" length of fiber sleeving onto the positive lead of the capacitor. Then connect the lead to the push-on connector at relay K1 lug 30 (S-1).
 - () Prepare a 5" small red stranded wire. Then install a push-on connector on one end of the wire and a small spring connector on the other end.
 - () Push the push-on connector on one end of the prepared red wire onto relay K1 lug 86.

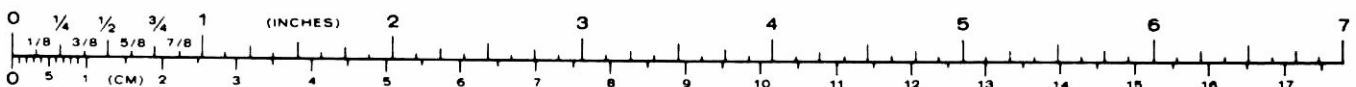

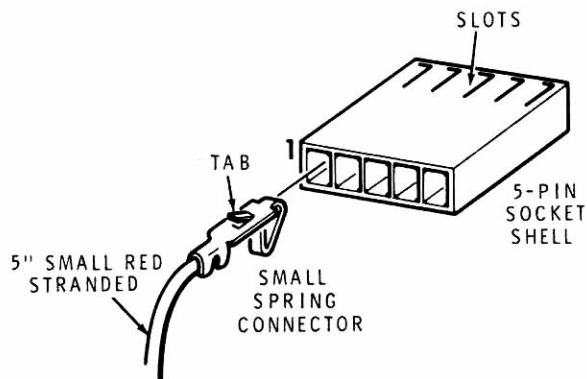
**Detail 15-10B**

- () Locate a 5-pin socket shell and label it "P551". Then refer to Detail 15-10B and push the spring connector on the free end of the red wire that you just prepared into hole 1 until it locks in place.
- () Prepare a 6" medium red stranded wire. Then install a push-on connector on one end of the wire and a large spring connector on the other end (see Detail 15-10C).

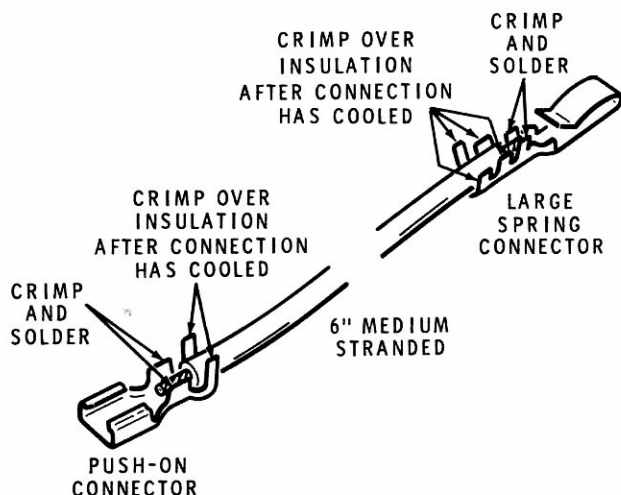
**Detail 15-10C**

- () Push the push-on connector on one end of the prepared red wire onto relay K1 lug 87 (use the lug 87 that is nearest the center of the relay lugs).
- () Slide a 3/4" length of fiber sleeving onto the lead coming from diode D3. Then connect and solder the end of the lead to the push-on connector on relay K1 lug 87.
- () Position a large 4-pin plug shell as shown in Detail 15-10D (note the location of the locking tab and the ridges). Position the large spring connector on the free end of the red wire as shown and push it into hole 4 of the shell until it locks in place.

- () Prepare the following wires:

8" small red stranded

5" small black stranded

6" medium red stranded

2" small red stranded

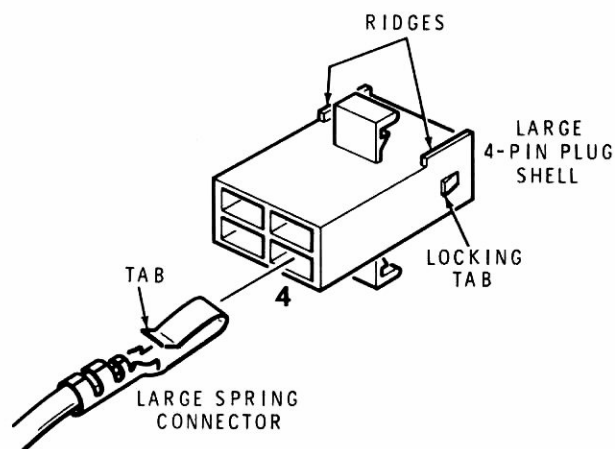
**Detail 15-10D**

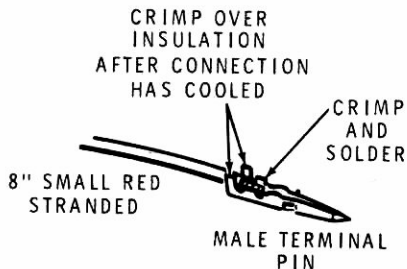

Detail 15-10E

- () Refer to Detail 15-10E and install a male terminal pin on one end of the 8" small red stranded wire. Set this wire aside temporarily.
- () Install a small spring connector on one end of the 5" small black stranded wire. Set this wire aside temporarily.
- () Install a large spring connector on one end of the 6" medium red stranded wire.

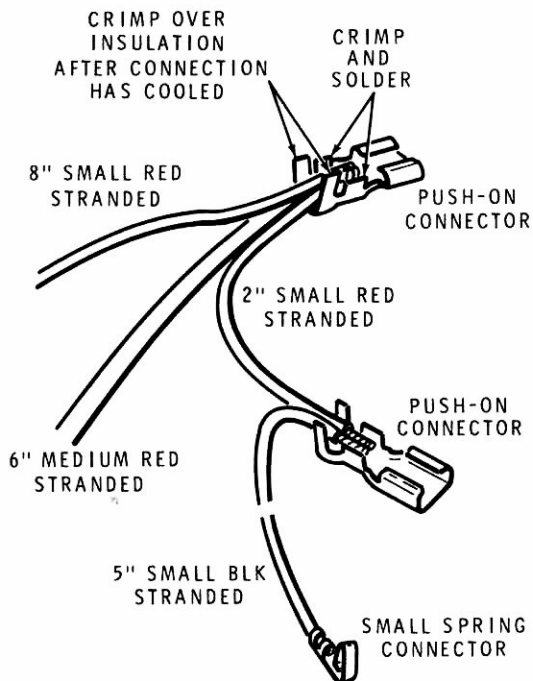

Detail 15-10F

- () Refer to Detail 15-10F and install a single push-on connector on the free ends of the 6" medium red stranded wire, the 8" small red stranded wire, and on one end of the 2" small red stranded wire.
- () Refer again to Detail 15-10F and install a single push-on connector on the free ends of the 2" small red stranded wire and the 5" small black stranded wire.
- () Push the push-on connector (with one small red and one small black stranded wire) onto relay K1 lug 85.
- () Push the push-on connector (with three red wires) onto the remaining lug 87 of relay K1.
- () Locate socket P551 coming from relay lug 86. Then push the small spring connector on the free end of the 5" small black stranded wire into hole 2 of this socket until it locks in place.
- () Refer to Detail 15-10G and push the large spring connector on the free end of the 6" medium red stranded wire into hole 3 of the large 4-pin plug shell until it locks in place. Be sure to position the connector and shell with the tabs as shown.

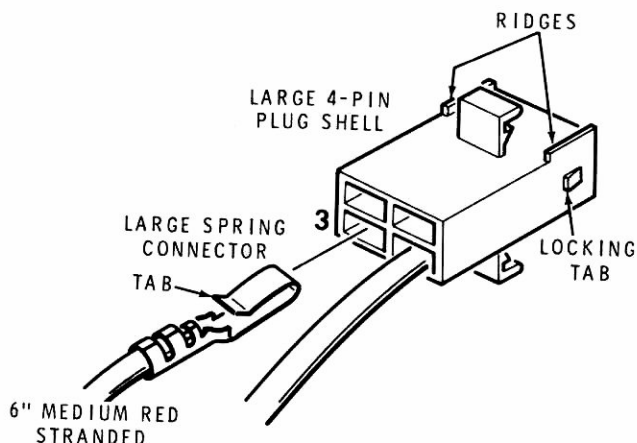

Detail 15-10G

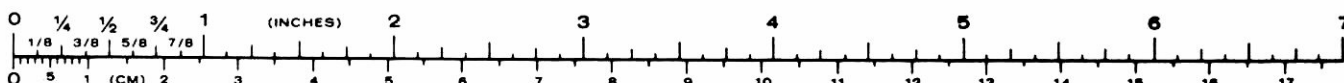

Heathkit®

NOTE: The male terminal pin on the free end of the 8" small red stranded wire will be installed in a connector shell later.

- () Prepare two 5" medium white stranded wires. Then install a large spring connector on one end of each wire.
- () Connect the free end of one of the medium white stranded wires to the top hole in solder lug RH (S-1). Be sure the wire that was previously soldered in the bottom hole of this solder lug also remains well soldered. Push the large spring connector on the other end of this wire into hole 1 of the large 4-pin plug shell until it locks in place.
- () Connect the free end of the remaining medium white stranded wire to the bottom hole in solder lug RJ (S-1). Push the large spring connector on the other end of this wire into hole 2 of the large 4-pin plug shell until it locks in place.
- () Install small spring connectors on the following wires coming from main harness breakout #24:
 - Black
 - White-green
 - Gray
- () Locate socket P551. Then push the spring connector on the end of the black wire coming from main harness breakout #24 into hole 3 of this socket shell.
- () Locate a 3-pin socket shell and label it "P552". Then push the spring connector on the gray wire coming from main harness breakout #24 into hole 1 of this socket shell.
- () Locate a 5-pin socket shell and label it "P553". Then push the white-green wire coming from main harness breakout #24 into hole 3 of this socket shell.
- () Install male terminal pins on the inner and shield leads of the shielded cable coming from grommet RF. These pins will be installed in a socket shell later.
- () Install small spring connectors on the following wires coming from main harness breakout #25:
 - White-green
 - Green
 - White-yellow
 - White-gray
- () Locate a 5-pin socket shell and label it "P651". Then push the spring connectors on the ends of the wires coming from main harness breakout #25 as follows:
 - () White-green into hole 2.
 - () Green into hole 3.
 - () White-yellow into hole 4.
 - () White-gray into hole 5.
- () Prepare the following wires:
 - 12" small blue stranded
 - 7" small red stranded
 - 10" small black stranded
- () Install small spring connectors on both ends of the 12" small blue wire.
- () Locate socket P651. Then push the spring connector on one end of the 12" small blue wire into hole 1 of this socket.
- () Locate socket P551. Then push the spring connector on the free end of the 12" small blue wire into hole 5 of this socket.
- () Install a small spring connector on one end of the 7" small red wire. Then locate socket P553 and push the connector on the red wire into hole 1 of this socket shell.
- () Connect the free end of the 7" small red wire to terminal strip RA lug 2 (S-5). Make sure the capacitor lead that was previously soldered in the eyelet of this lug remains well soldered.

- () Install a small spring connector on one end of the 10" small black wire end and a male terminal pin on the other end.

- () Locate socket P551. Then push the spring connector on the end of the 10" small black wire into hole 4 of this socket shell.

Position a 6-pin socket shell as shown in Detail 15-10H (note the location of the notch). Then push the male terminal pins on the wires coming from other connectors and grommet RF into the socket shell as follows:

- () Red wire into hole 4.
- () Black wire into hole 2.
- () Inner lead of the shielded cable into hole 1 and the shield wires into hole 3.

- () Prepare the following wires:

10-1/2" orange stranded

9-1/2" gray stranded

- () Install small spring connectors on both ends of both of the prepared wires.

- () Locate socket P553. Then push the small spring connector on one end of the 10-1/2" orange wire into hole 2 of this socket shell.

- () Push the small spring connector on one end of the 9-1/2" gray wire into P553 hole 4.

- () Locate a 3-pin socket shell and label it P554. Then insert the spring connector on the free end of the gray wire into hole 1 of this socket shell.

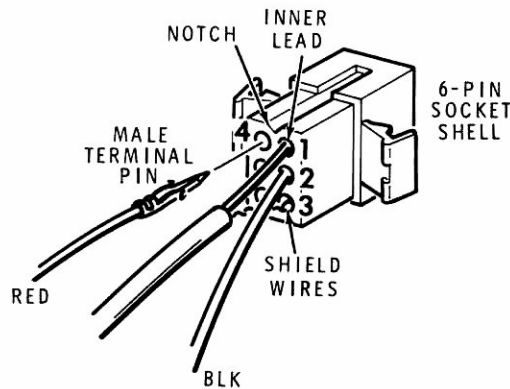

Detail 15-10H

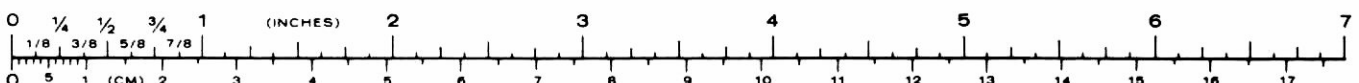

Heathkit®

- () Refer to Detail 15-10J and prepare a 21" black shielded cable as shown.
- () Install small spring connectors on the inner and shield leads at end A of the prepared shielded cable.
- () Refer to Detail 15-10K and install a phono plug on the free end of the prepared shielded cable.
- () Route the shielded cable behind capacitor C3 as shown and along the top edge of the rear chassis. Push the spring connector end of the cable through grommet RE for 2".

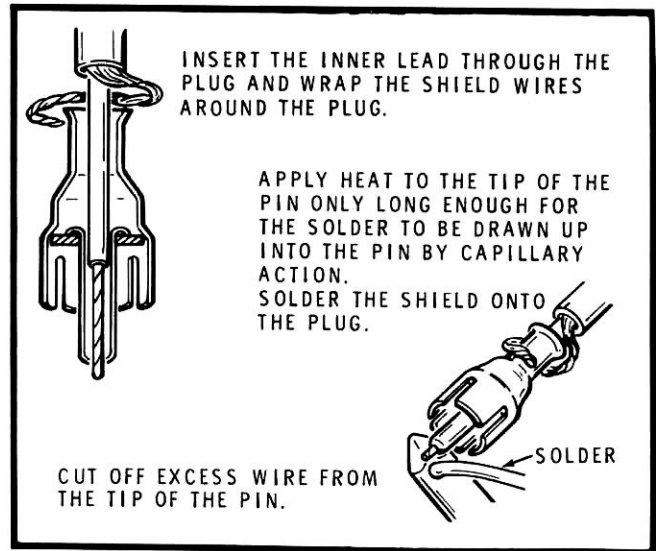

Detail 15-10K

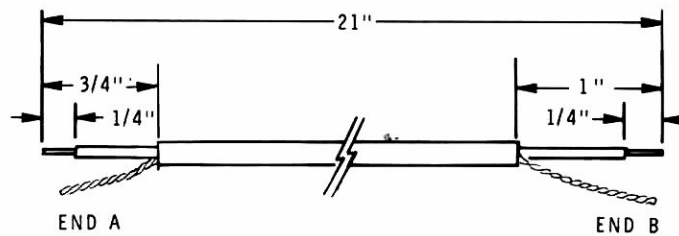

Detail 15-10J

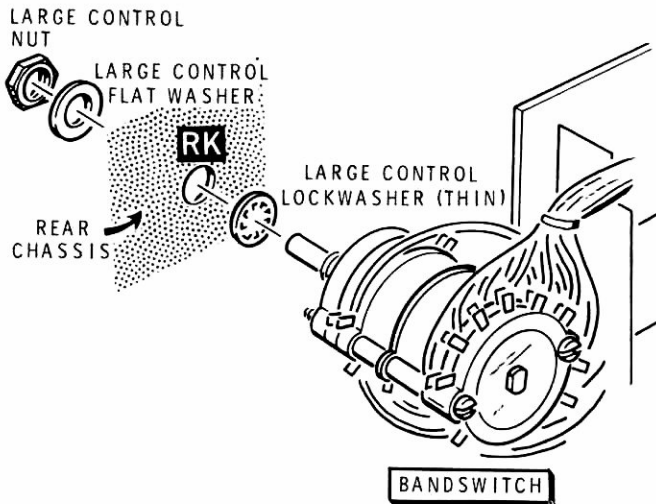
**Detail 15-11A**

Refer to Pictorial 15-11 (Illustration Booklet, Page 38) for the following steps.

- () Position the filter circuit board/bandswitch assembly near the rear chassis as shown.
 - () Refer to Detail 15-11A and place a large control lockwasher (thin) onto the shaft of the bandswitch. Then mount the bandswitch to the rear chassis at RK with a large control flat washer and a large control nut.
 - () Refer to Detail 15-11B and mount the filter circuit board to the rear chassis as shown. Use six 6-32 x 3/8" hex head screws. Be sure the shielded cable stays in place and be sure you do not pinch any wires.
- () Dress the shielded cables coming from the lower edge of the filter circuit board as neatly as possible. Then refer to the inset drawing on the Pictorial and install a cable tie onto the cables in the area shown to help hold them in position.
 - () Dress the shielded cables coming from the top edge of the filter circuit board as neatly as possible. Then install two cable ties onto the cables in the areas shown to help hold them in position.
 - () Push socket P551 (with the red and three black wires) onto plug P551 on the filter circuit board. Be sure the red wire is up as shown.
 - () Push socket P552 (with the gray wire coming from grommet RF) onto plug P552 on the filter circuit board. Be sure the gray wire is up as shown.
 - () Push socket P553 (with the red, orange, white-green, and gray wires) onto plug P553 on the filter circuit board. Be sure the red wire is up as shown.
 - () Route the gray wire coming from socket P553 along the top edge of the filter circuit board. Then push socket P554, on the free end of this wire, onto plug P554 on the filter circuit board. Be sure the gray wire is up as shown.

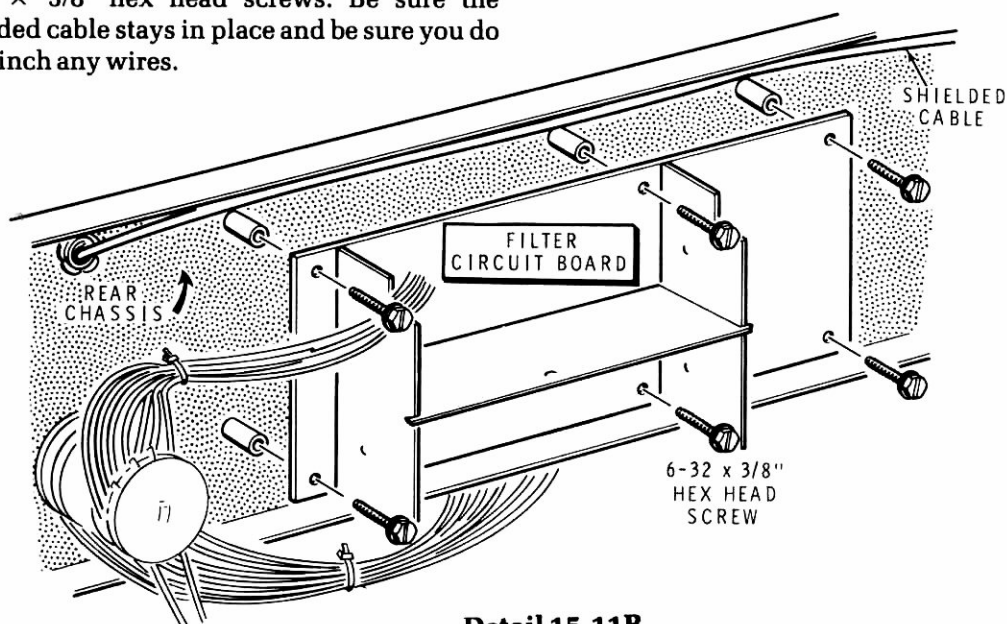
**Detail 15-11B**

Heathkit®

- () Route the orange wire coming from socket P553 along the top edge of the filter circuit board. Then push the spring connector on the free end of this wire through rear chassis grommet RE.
- () Locate a 3-pin socket shell and label it "P402". Then push the spring connectors on the wire and cable coming from rear chassis grommet RE into the socket shell as follows:
 - () Orange wire into hole 3.
 - () Shield wire of the cable into hole 2.
 - () Inner wire of the cable into hole 1.
- () Install a medium knob with decorative insert on the shaft of switch SW9. Line up the pointer with the "CW-N" mark on the front panel before you tighten the setscrew.
- () Similarly, install a medium knob with decorative insert on the shaft of switch SW1. Line up the pointer with the "80" mark on the front panel before you tighten the setscrew.
- () Install medium knobs without inserts onto the larger shafts of controls R2 and R4. Be sure to line up the pointers with the front panel mark indicated on the Pictorial.
- () Install small knobs onto the smaller shafts of controls R2 and R4. Be sure to line up the pointers with the front panel marks indicated on the Pictorial.

Refer to Pictorial 15-12 (Illustration Booklet, Page 39) for the following steps.

- () Turn the shafts of controls R2 and R4 fully counterclockwise. Be sure to turn the smaller shaft of control R2 until it clicks. NOTE: You may have to use pliers to turn the smaller shaft of control R2.
- () Turn the shafts of switches SW9 and SW1 fully counterclockwise.
- () Refer to Detail 15-12A and use a medium allen wrench to start 6-32 × 1/8" setscrews into the two medium knobs with decorative inserts and the three medium knobs without decorative inserts. Use a small allen wrench to start 4-40 × 1/8" setscrews into the three small knobs.
- () Turn both shafts of control R3 to their detent positions at the centers of their rotation.
- () Install a medium knob without insert onto the larger shaft of control R3. Be sure to line up the pointer with the "0" mark on the front panel.
- () Turn the knob on control R3 fully counterclockwise.
- () Install a small knob onto the smaller shaft of control R3. Be sure to line up the pointer with the "0" mark on the front panel.

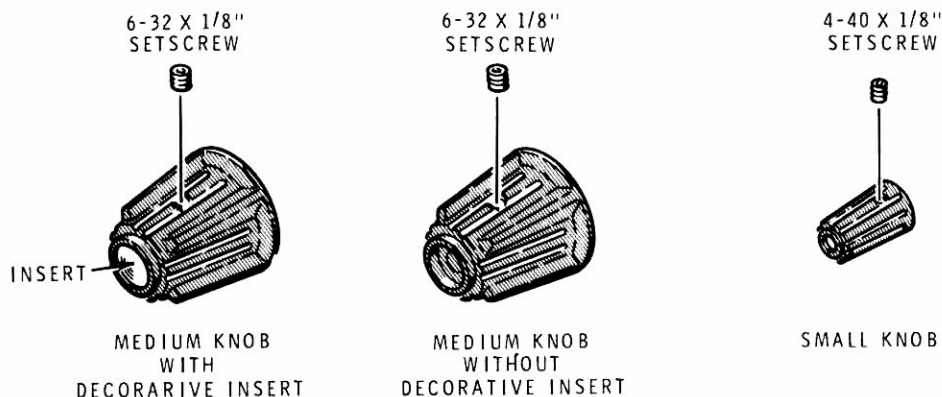

Detail 15-12A

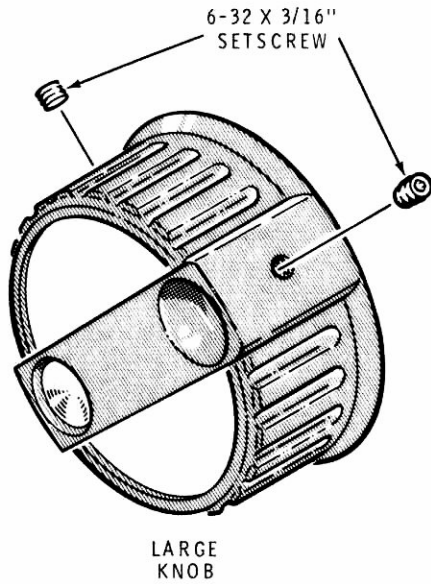
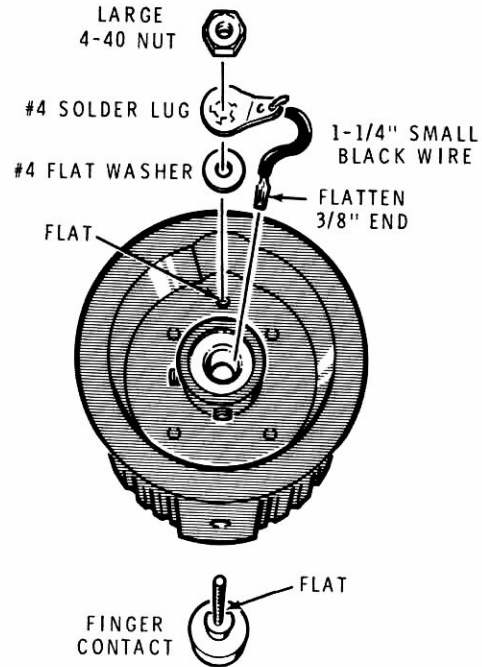
**Detail 15-12B****Detail 15-12C**

- () Refer to Detail 15-12B and start two 6-32 × 3/16" setscrews into the large knob.
- () Refer to Detail 15-12C and use the following procedure to mount the finger contact in the large knob:
1. Prepare a 1-1/4" small black stranded wire. Remove 1/4" of insulation from one end of this wire and 3/8" of insulation from the other end.
 2. Solder the 1/4" end of the black wire to a #4 solder lug. Then use pliers to flatten the 3/8" end of the wire.
 3. Line up the flats in the finger contact and the knob. Then start the finger contact into its hole in the larger knob.
 4. Mount the solder lug to the large knob and finger contact. Use a #4 flat washer and a large 4-40 nut. Be sure to position the solder lug as shown. Do not over-tighten this hardware.
 5. Insert the flattened end of the black wire into the hole in the center of the large knob.
- () Install the large knob onto the tuning shaft as follows:
1. Start the knob onto the shaft so the wire is against the flat in the shaft.
 2. Push the knob onto the shaft and tighten both setscrews.

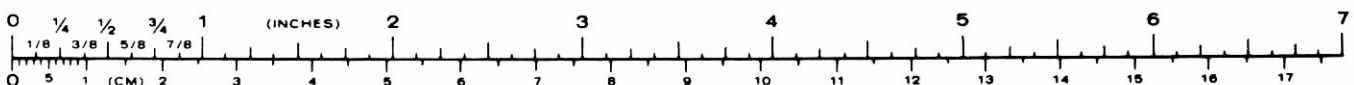

Heathkit®

Refer to Pictorial 16-1 (Illustration Booklet, Page 40) for the following steps.

- () Position the chassis as shown in the Pictorial.
- () Unfold the cable harness (#134-1262) as shown in Detail 16-1A (Illustration Booklet, Page 41). Refer to the cable colors at each breakout to be sure you have the harness positioned properly. Then wrap a piece of tape (not supplied) around the harness between breakouts #4 and #6. NOTE: You will use this piece of tape for reference in the next step.
- () From the underside of the chassis, carefully push breakouts #1 through #5 (all of the breakouts on one side of the tape) up through chassis grommet B. Be careful not to damage the spring connectors on some of the shielded cables.
- () Route cable harness breakouts #1 through #4 as shown. Then secure this part of the harness in place with the two long #6 solder lugs indicated.
- () Route cable harness breakout #5 across the front of the chassis as shown. Then secure the cable harness to the main harness with a cable tie in the area shown.
- () Install small spring connectors on the end of the yellow cable coming from cable harness breakout #3.
- () Locate socket P915 coming from the main harness. Then push the spring connectors on the end of the yellow cable, coming from cable harness breakout #3, into this socket shell as follows:
 - Inner lead into hole 3.
 - Shield wires into hole 1.
- () Install small spring connectors on the end of the green cable coming from cable harness breakout #3.
- () Locate socket shell P913 coming from the main harness. Then push the spring connectors on the end of the green cable, coming from cable harness breakout #3, into this socket shell as follows:
 - Inner lead into hole 2.
 - Shield wires into hole 3.

- () Locate a 2-pin socket shell and label it "P917". Then push the spring connectors on the end of the orange cable, coming from cable harness breakout #2, into this socket shell as follows:
 - Inner lead into hole 2.
 - Shield wires into hole 1.

- () Locate a 2-pin socket shell and label it "P919". Then push the spring connectors on the end of the red cable, coming from cable harness breakout #1, into this socket shell as follows:
 - Inner lead into hole 1.
 - Shield wires into hole 2.

- () Locate a 2-pin shell and label it "P906". Then push the spring connectors on the end of the black (unmarked) cable, coming from cable harness breakout #1, into this socket shell as follows:
 - Inner lead into hole 2.
 - Shield wires into hole 1.

- () Install small spring connectors on the end of the violet cable coming from cable harness breakout #5.

- () Locate socket P912 coming from the main harness. Then push the spring connectors on the end of the violet cable, coming from cable harness breakout #5, into this socket shell as follows:
 - Inner lead into hole 2.
 - Shield wires into hole 4.

- () Install small spring connectors on the end of the white cable coming from cable harness breakout #5.

- () Push the spring connectors on the end of the white cable, coming from cable harness breakout #5, into this same socket shell (P912) as follows:
 - Inner lead into hole 3.
 - Shield wires into hole 5.

- () Locate a 2-pin socket shell and label it "P914-12". Then push the spring connectors on the end of the blue cable, coming from cable harness breakout #5, into this socket shell as follows:

Inner lead into hole 12.

Shield wires into hole 11.

- () Locate a 2-pin socket shell and label it "P406". Then push the spring connectors on the end of the yellow-green cable, coming from cable harness breakout #5, into this socket shell as follows:

Inner lead into hole 1.

Shield wires into hole 2.

Refer to Pictorial 16-2 (Illustration Booklet, Page 42) for the following steps.

- () Position the chassis upside-down as shown in the Pictorial.
- () Route cable harness breakouts #12 through #14 across the center of the chassis as shown. Then secure it in place with the two long #6 solder lugs indicated. Route the free end of the white-blue cable coming from breakout #14 through rear chassis grommet RF.
- () Route cable harness breakouts #7 and #8 across the front of the chassis as shown. Then use a cable tie to secure the cable harness (near breakout #7) to the main harness in the area shown.
- () Route cable harness breakouts #10 and #11 across the front of the chassis as shown. Then use a cable tie to secure the cable harness to the main harness in the area shown.

Connect the cables coming from cable harness breakout #7 to control R4B as follows:

- () Inner lead of the orange cable to lug 2 (S-1) and the shield wires to lug 1 (NS).
- () Inner lead of the green cable to lug 3 (S-1) and the shield wires to lug 1 (S-3).

Connect the cables coming from cable harness breakout #8 as follows:

- () Inner lead of the white-blue cable to phone jack J3 lug 2 (S-1) and the shield wires to lug 1 (NS).
- () Inner lead of the blue cable to phone jack J3 lug 3 (S-2) and the shield wires to lug 1 (S-3).
- () Inner lead of the yellow cable to microphone socket J2 lug 1 (S-1) and the shield wires to lug 2 (S-2).
- () Locate a 2-pin socket shell and label it "P103". Then insert the spring connectors on the yellow-green cable into this socket as follows:

Inner lead into hole 1.

Shield wires into hole 2.

Connect the cables coming from cable harness breakout #10 to control R2B as follows:

- () Inner lead of the violet cable to lug 2 (S-1) and the shield wires to lug 1 (NS).
- () Inner lead of the white cable to lug 3 (S-1) and the shield wires to lug 1 (S-3).
- () Locate socket P408 coming from the main harness. Then push the spring connectors on the end of the white-violet cable, coming from cable harness breakout #11, into this socket shell as follows:

Inner lead into hole 4.

Shield wires into hole 3.

- () Locate socket P407 coming from the main harness. Then push the spring connectors on the end of the yellow-red cable, coming from cable harness breakout #11, into this socket shell as follows:

Inner lead into hole 5.

Shield wires into hole 4.

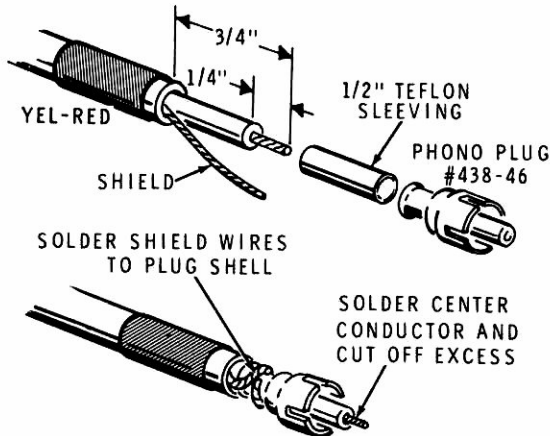

Detail 16-2A

- () Locate a 2-pin socket shell and label it "P1107". Then push the spring connectors on the end of the red cable, coming from cable harness breakout #12, into this socket shell as follows:

Inner lead into hole 1.

Shield wires into hole 2.

- () Locate a 2-pin socket shell and label it "P1105". Then push the spring connectors on the end of the white-violet cable, coming from cable harness breakout #12, into this socket shell as follows:

Inner lead into hole 2.

Shield wires into hole 1.

- () Locate a 2-pin socket shell and label it "P1102". Then push the spring connectors on the end of the black (or unmarked) cable, coming from cable harness breakout #13, into this socket shell as follows:

Inner lead into hole 2.

Shield wires into hole 1.

- () Refer to Detail 16-2A and install a phono plug on the end of the yellow-red cable, coming from cable harness breakout #14, as shown. Be sure to slide a 1/2" length of Teflon sleeving over the center conductor as shown.

- () Install male terminal pins on the end of the white-blue cable coming from cable harness breakout #14 (cable that passes through rear chassis grommet RF).

- () Push the male terminal pins on the end of the white-blue cable into the 6-pin socket shell as follows:

Inner lead into hole 5.

Shield wires into hole 6.

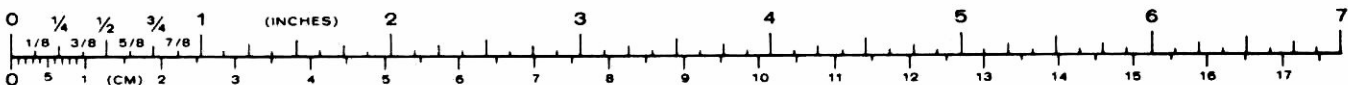

AUDIO CIRCUIT BOARD INSTALLATION

Refer to Pictorial 16-3 (Illustration Booklet, Page 43) for the following steps.

- () Position the chassis right-side-up as shown in the Pictorial.
- () Position all of the wires and cables away from the area of the chassis designated as "audio circuit board" on the Pictorial.
- () Refer to Detail 16-3A and mount the audio circuit board to the chassis as shown. Use seven 6-32 × 3/8" hex head screws. Be careful not to pinch any wires or cables between the circuit board and the chassis. Also, note that the harnesses are routed **above** the front edge of the circuit board.
- () Refer to Detail 16-3B and push the 5-pin socket, coming from the audio circuit board, onto integrated circuit U906 as shown. Be sure the slots on this socket are **away** from the bandswitch shield.
- () Push socket P914 1-10, coming from the main harness, onto audio circuit board plug P914 pins 1-10. Be sure you use pins 1 through 10 of this plug. Also be sure to install this socket so the white-black wire is at plug pin 1.

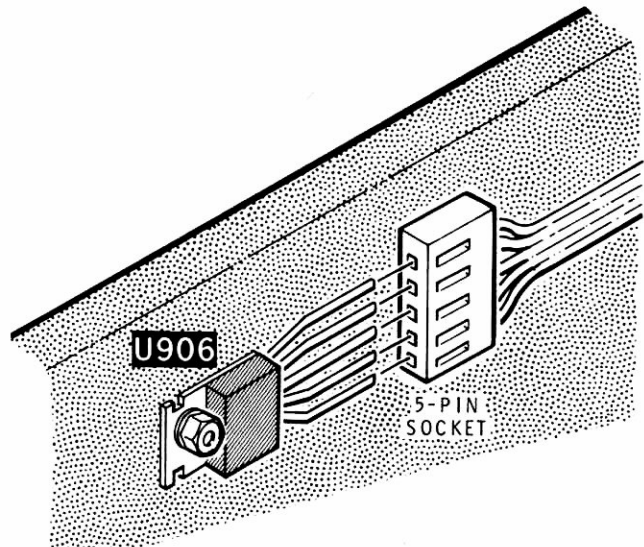

Detail 16-3B

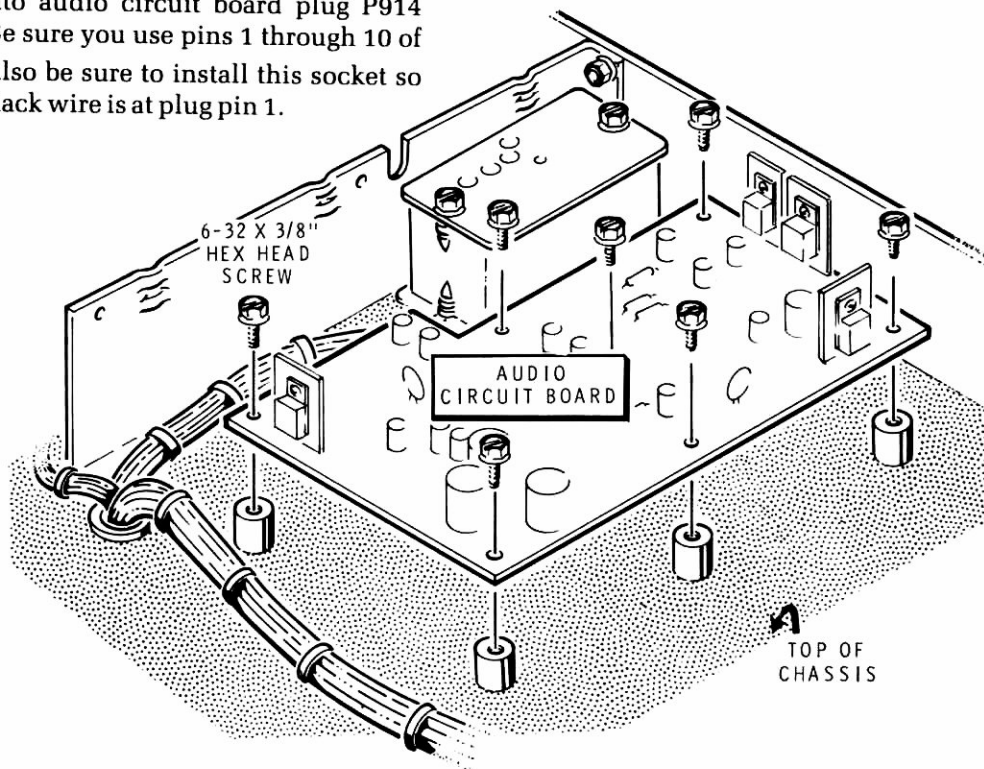

Detail 16-3A

Heathkit®

- () Push socket P914 11&12, coming from the cable harness, onto audio circuit board plug P914 pins 11 and 12. Be sure you install this socket so the inner lead of the shielded cable is at plug pin 12.
 - () Push socket P912, coming from the main and cable harnesses, onto audio circuit board plug P912. Be sure the violet wire (not the violet cable) in this socket is at plug pin 1.
 - () Push socket P915, coming from the main and cable harnesses, onto audio circuit board plug P915. Be sure the inner lead of the shielded cable in this socket is at plug pin 3.
 - () Push socket P916, coming from the main harness, onto audio circuit board plug P916. Be sure the slots in this socket are **away** from the nearby edge of the circuit board.
 - () Push socket P913, coming from the main and cable harnesses, onto audio circuit board plug P913. Be sure the brown wire in this socket is at plug pin 1.
 - () Push socket P917, coming from the cable harness, onto audio circuit board plug P917. Be sure the inner lead of the shielded cable in this socket is at plug pin 2.
 - () Push socket P908, coming from the main harness, onto audio circuit board plug P908. Be sure the white-gray wire in this socket is at plug pin 1.
 - () Push socket P911, coming from the display circuit board onto audio circuit board plug P911. Be sure the inner lead of the shielded cable in this socket is at plug pin 1.
 - () Push socket P909, coming from the display circuit board, onto audio circuit board plug P909. Be sure the inner lead of the shielded cable in this socket is at plug pin 1.
 - () Push socket P907, coming from the main harness, onto audio circuit board plug P907. Be sure the slots in this socket are **away** from the display circuit board.
 - () Push socket P919, coming from the cable harness, onto audio circuit board plug P919. Be sure the inner lead of the shielded cable in this socket is at plug pin 1.
 - () Push socket P906, coming from the cable harness, onto audio circuit board plug P906. Be sure the inner lead of the shielded cable in this socket is at plug pin 2.
 - () Push socket P904, coming from the display circuit board, onto audio circuit board plug P904. Be sure the slots in this socket are **away** from the display circuit board.
 - () Push socket P918, coming from the main harness, onto audio circuit board plug P918. Be sure the slots in this socket are **away** from the inverter assembly.
 - () Push socket P905 1-3, coming from the main harness, onto audio circuit board plug P905. Be sure the green wire in this socket is at plug pin 1. NOTE: A socket will be installed onto pins 4 and 5 of this plug later.
 - () Push socket P903, coming from the main harness, onto audio circuit board plug P903. Be sure the slots in this socket are **away** from the inverter assembly.
 - () Push socket P902, coming from the main harness, onto audio circuit board plug P902. Be sure the slots in this socket are **away** from the inverter assembly.
 - () Push socket P901, coming from the main harness onto audio circuit board plug P901. Be sure the white-black wires in this socket are at plug pins 1 and 2.
- Push the circuit board connectors on the free ends of the wires coming from the display circuit board onto the pins on the audio circuit board as follows:
- () Green wire onto pin J.
 - () Orange wire onto pin K.
 - () Blue wire onto pin I.
 - () Violet wire onto pin L.
 - () Use a cable tie at the indicated location to hold all of the wires and cables coming from the display circuit board neatly together.

Refer to Pictorial 16-4 (Illustration Booklet, Page 44) for the following steps.

- () Refer to Detail 16-4A and use a pair of pliers to push the steel blade into the smaller end of the nut starter until 1/8" remains exposed. Use this tool when you are instructed to adjust trimmer capacitors and the controls that are mounted on the circuit boards.

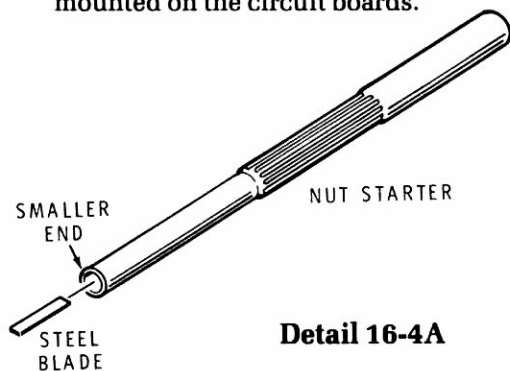

- () Position all exposed metal connectors (spring connectors, etc.) so they cannot touch anything other than the chassis.

NOTE: You will make some voltage checks in the following steps. This procedure assumes that you have the proper power supply and it is adjusted for 13.8 volts DC output. You should also have a speaker connected to the Transceiver. Refer to the "Installation" section of the Operation Manual for power supply and speaker connections.

- () Preset the front panel controls and switches as follows:

MODE — NORM
 MIC GAIN — Fully counterclockwise
 CW GAIN — Fully counterclockwise
 AF GAIN — Fully counterclockwise (until it clicks)
 RF GAIN — Fully clockwise
 RIT — 0 (detent)
 IF SHIFT — 0 (detent)
 BAND — 80
 REC/TUNE button — Released (REC)
 PTT/VOX button — Released (PTT)
 AGC button — Released (FAST)

- () Connect your power supply and speaker to the large 4-pin plug shell and the 6-pin socket shell coming from the rear chassis.

NOTE: If you do not obtain the proper results in any of the following steps, immediately turn the Transceiver off. Locate and correct the problem before you continue to the next step.

- () Turn the AF GAIN control clockwise until it clicks (ON). The relay on the rear chassis should click and the meter lamps should light. You may also hear a slight hiss coming from the speaker.
- () Set your voltmeter to read +15 volts DC.
- () Connect the negative voltmeter lead to any metal part of the chassis. Leave this lead connected to the chassis until you are directed to disconnect it.
- () Touch the voltmeter probe to terminal strip RA lug 1. The meter should indicate 13.8 volts DC. If you do not obtain the correct voltage, check your power supply for the correct voltage and connection to the Transceiver. Also check the wiring of relay K1.
- () Touch the voltmeter probe to feedthrough capacitor C513 on the inverter assembly. The meter should indicate 13.8 volts. If you do not obtain the correct voltage, check plug P901 on the audio circuit board and the wiring at feedthrough capacitor C513.
- () Touch the voltmeter probe to plug P553 pin 2 (orange wire) on the filter circuit board. The meter should indicate 10 to 11 volts. If you do not obtain the correct voltage, check transistors Q555, Q556, and diode D555 on the filter circuit board.
- () Touch the voltmeter probe to feedthrough capacitor C515 on the inverter assembly. The meter should indicate 11 to 12 volts. If you do not obtain the correct voltage, check integrated circuit U503 in the inverter assembly.
- () Set your voltmeter to read +25 volts DC.
- () Touch the voltmeter probe to feedthrough capacitor C514 on the inverter assembly. The meter should indicate 18 to 22 volts. If you do not obtain the correct voltage, check integrated circuit U502 in the inverter assembly.

Heathkit[®]

- () Set your voltmeter to read +3 volts DC.
- () Touch the voltmeter probe to plug P905 pin 2 (wht-grn wire) on the audio circuit board. Then adjust bias control R931 on the audio circuit board until the meter indicates 2.8 volts.
- () Turn the AF GAIN control fully clockwise.
- () Use a small screwdriver blade to touch the indicated lead of resistor R1004 (brn-red-yel) on the audio circuit board. You should hear a 60 Hz hum. If you do not obtain a hum, refer to "In Case of Difficulty" in the Operation Manual.
- () Turn the Transceiver off and disconnect the power supply and speaker.

BFO CIRCUIT BOARD INSTALLATION

Refer to Pictorial 16-5 (Illustration Booklet, Page 45) for the following steps.

- () Position all of the wires and cables away from the area of the chassis designated as "BFO circuit board" on the Pictorial.
- () Refer to Detail 16-5A and mount the BFO circuit board to the center shield as shown. Use two $5/32" \times 3/8"$ long spacers and two 6-32 $\times 5/8"$ black phillips head screws.

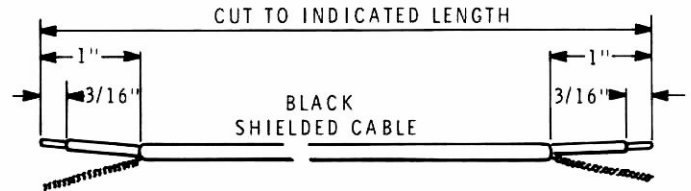

Detail 16-5B

- () Push socket P803, coming from the main harness, onto BFO circuit board plug P803. Be sure the gray wire in this socket is at plug pin 1.
- () Push socket P804, coming from the main harness, onto BFO circuit board plug P804. Be sure the white-red wire in this socket is at plug pin 1.
- () Refer to Detail 16-5B and prepare a 7" and a 12" length of black shielded cable.
- () Install small spring connectors on both ends of the 7" cable and **one end** of the 12" cable.
- () Locate a 2-pin socket shell and label it "P905 4&5". Then refer to Detail 16-5C and push the spring connectors on one end of the 7" cable into this socket shell as follows:

Inner lead into hole 5.

Shield wires into hole 4.

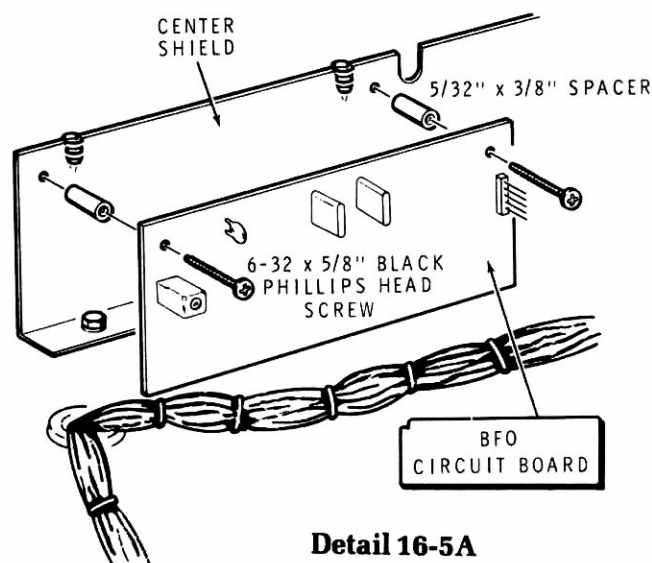

Detail 16-5A

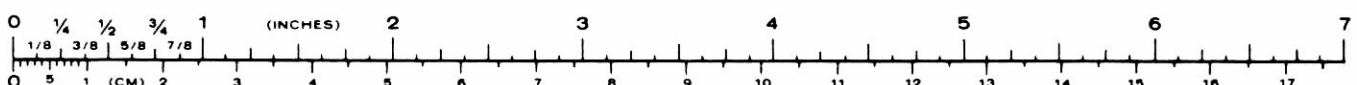

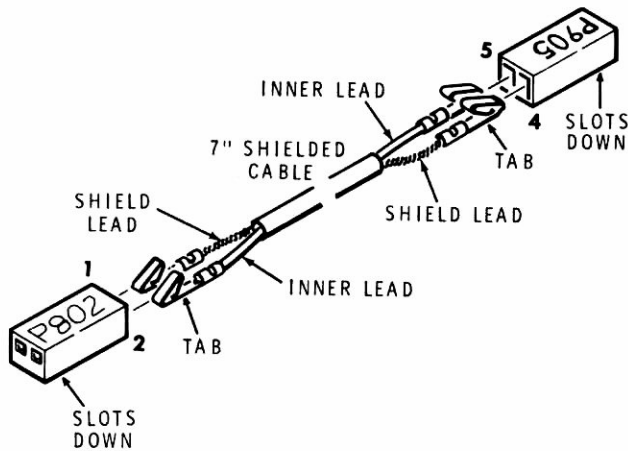
**Detail 16-5C**

- () Locate a 2-pin socket shell and label it "P802". Then refer again to Detail 16-5C and push the spring connectors on the free end of the 7" cable into this socket shell as follows:

Inner lead into hole 2.

Shield wires into hole 1.

- () Push socket P905 4&5, on one end of the 7" cable, onto audio circuit board plug P905 pins 4 and 5. Be sure the inner lead of the shielded cable in this socket is at plug pin 5.
- () Push socket P802, on the free end of the 7" cable, onto BFO circuit board plug P802. Be sure the inner lead of the shielded cable in this socket is at plug pin 2.
- () Secure the 7" cable in place with the long #6 solder lug mounted near the front of the inverter assembly.

- () Locate a 2-pin socket shell and label it "P801". Then insert the spring connectors on one end of the 12" cable into this socket shell as follows:

Inner lead into hole 2.

Shield wires into hole 1.

- () Push socket P801, on one end of the 12" cable, onto BFO circuit board plug P801. Be sure the inner lead of the shielded cable in this socket is at plug pin 2.
- () Route the free end of the 12" cable down through chassis grommet B as shown.
- () Install small spring connectors on the free end of the 12" cable.
- () Locate a 2-pin socket shell and label it "P106". Then push the spring connectors on the free end of the 12" shielded cable into this socket shell as follows. NOTE: This socket will be connected to a circuit board plug later.

Inner lead into hole 1.

Shield wires into hole 2.

NOTE: In the following steps, if you are unable to resolve a problem, refer to the boxed information immediately following the step. You will note that there is a listing of "Possible Causes." If you are unable to resolve a problem after checking the list of possible causes, turn off the Transceiver and refer to the "In Case of Difficulty" section of this Manual. Do not proceed until you have found and corrected the problem.

Refer to Pictorial 16-6 (Illustration Booklet, Page 45) for the following steps.

- () Connect the common lead of your voltmeter to the chassis.
- () Set the voltmeter to read +15-volts DC.
- () Reconnect the power supply and speaker to the Transceiver.
- () Turn the Transceiver on.
- () Touch the voltmeter probe to P804 pin 1 (white-red wire) on the BFO circuit board. You should measure 9 volts DC.

POSSIBLE CAUSES

1. Socket P804 connected backwards; white-red wire should be on top (pin 1).
2. Open white-red wire to P804-1.

- () Turn the Transceiver off and disconnect the power supply and speaker. Also set the voltmeter aside temporarily.

CONTROLLER CIRCUIT BOARD INSTALLATION

Refer to Pictorial 16-7 (Illustration Booklet, Page 46) for the following steps.

- () Position the chassis right-side-up as shown in the Pictorial.
- () Position all of the wires and cables away from the area of the chassis designated as "controller circuit board" on the Pictorial.

() Position the controller circuit board near the chassis as shown in Detail 16-7A. Then start the shielded cables coming from the foil side of the circuit board into their corresponding chassis holes. Be sure each cable goes into the correct hole.

() Refer again to Detail 16-7A and mount the controller circuit board to the chassis as shown. Use four 6-32 \times 3/8" hex head screws and two 6-32 \times 1/4" hex studs. Be careful not to pinch any wires or cable between the circuit board and the chassis.

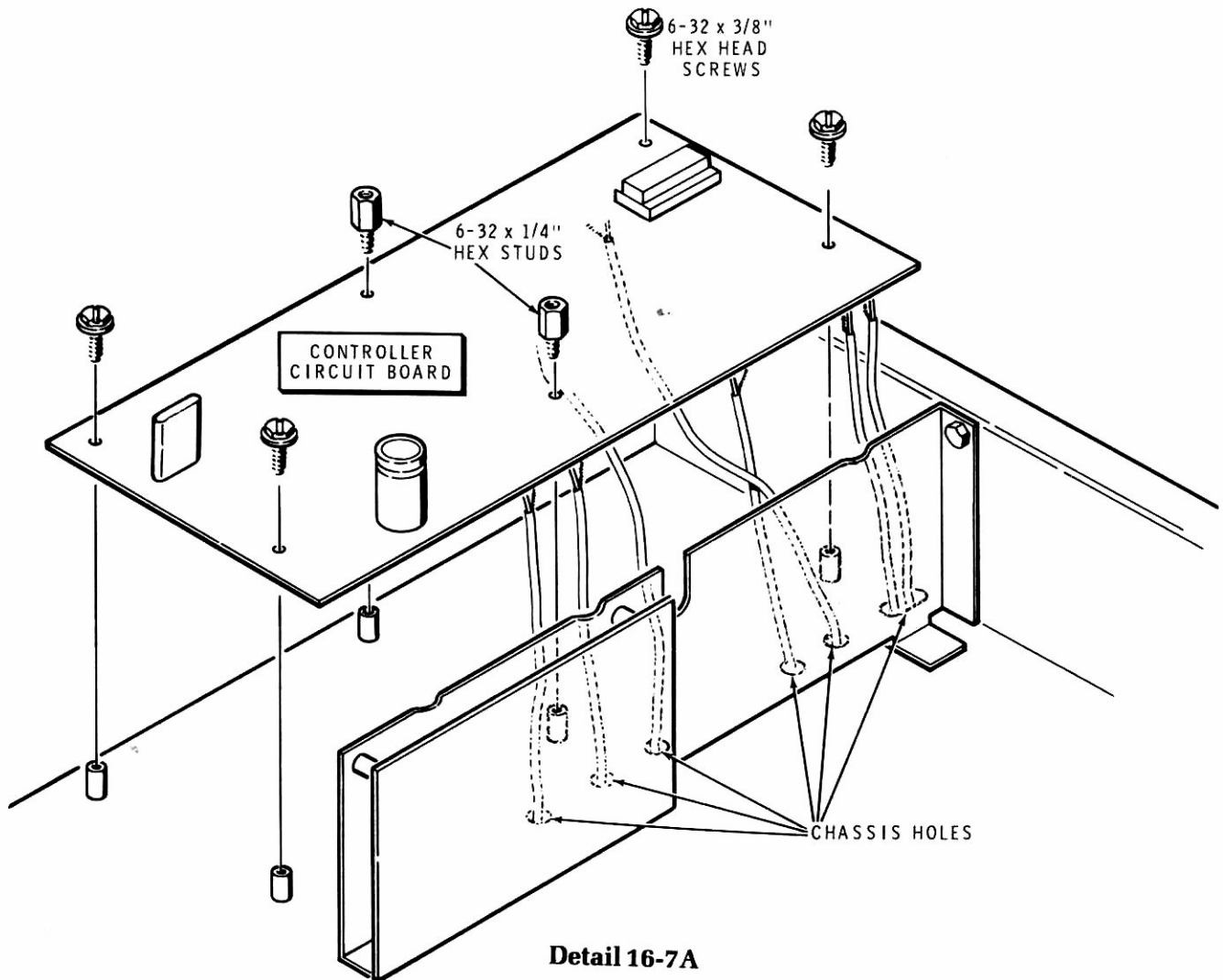

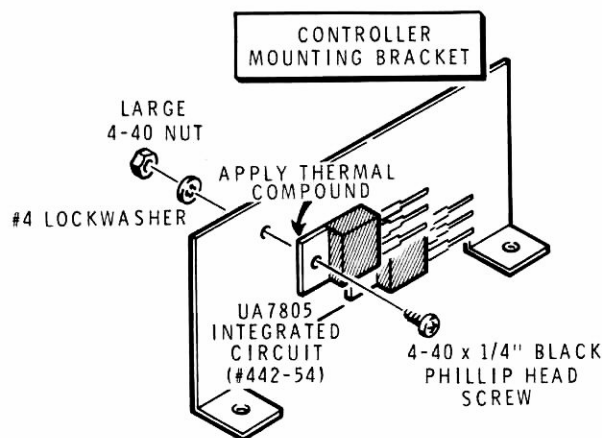

Detail 16-7B

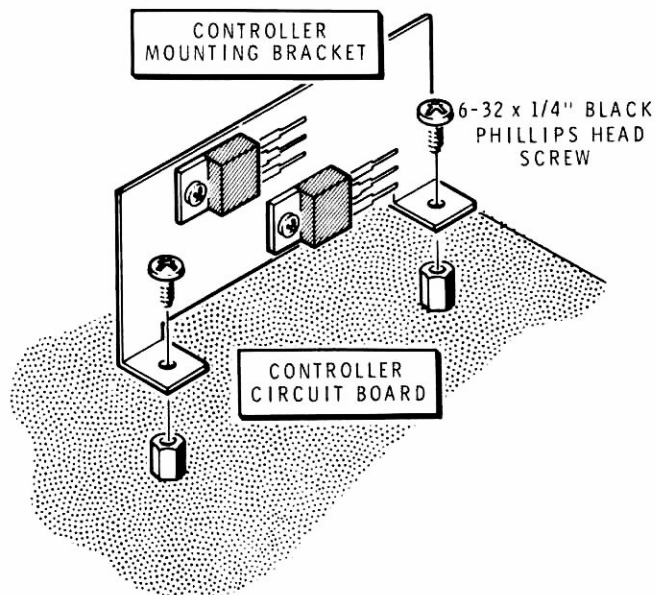

Detail 16-7C

- () U715: Refer to Detail 16-7B and use the following procedure to mount a UA7805 integrated circuit (#442-54) to the controller mounting bracket:
 1. Apply a thin layer of thermal compound onto the flat metal side of the integrated circuit.
 2. Mount the integrated circuit to the controller mounting bracket at U715. Use 4-40 × 1/4" black phillips head hardware (use a large 4-40 nut). Be sure to position the integrated circuit as shown in the Pictorial before you tighten the hardware.
- () U714: Similarly, mount a UA7805 integrated circuit (#442-54) to the controller mounting bracket at U714. Position the integrated circuit as shown in the Pictorial before you tighten the hardware.
- () Refer to Detail 16-7C and mount the prepared controller mounting bracket onto the controller circuit board as shown. Use two 6-32 × 1/4" black phillips head screws.
- () Push the 3-pin socket coming from the controller circuit board holes at U14 onto the leads of integrated circuit U714. Be sure to install this socket so the slots are away from the mounting bracket.
- () Push the 3-pin socket coming from the controller circuit board holes at U15 onto the leads of integrated circuit U715. Be sure to install this socket so the slots are away from the mounting bracket.
- () Push socket P703, coming from the display circuit board and the main harness, onto controller circuit board plug P703. Be sure the white-orange wire in this socket is at plug pin 1.
- () Push socket P701, coming from the main harness and a separate shielded cable, onto controller circuit board plug P701. Be sure the shield wires of the shielded cable in this socket are at plug pin 1.
- () Push the circuit board connector on the long green wire, coming from main harness breakout #7, onto controller circuit board pin N.

Push the circuit board connectors on the wires coming from main harness breakout #6 onto the controller circuit board pins as follows:

- () White-black wire onto pin +13.8.
- () White-gray wire onto pin $\phi 2$.
- () White-green wire onto pin $\phi 1$.
- () Green wire onto pin A.
- () Push socket P702, coming from the display circuit board, onto controller circuit board plug P702. Be sure the slots on this socket are **toward** integrated circuit U710.
- () Refer to the inset drawing on the Pictorial and cut through one side of the 3/8" rubber grommet as shown.
- () Place the rubber grommet on the 4-wire cable coming from controller circuit board holes C, D, E, and F. Then push the grommet into slot CA in the center shield. Be sure the cut side of the grommet is down toward the bottom of the slot. Also be sure to route this cable under the controller mounting bracket as shown.
- () Locate the spring connector on the free end of the green wire coming from main harness breakout #3. Then push this spring connector into hole 5 of socket P805 (coming through grommet CA).
- () Push socket P805, coming from the controller circuit board, onto BFO circuit board plug P805. Be sure the black wire in this socket is at plug pin 1.
- () Prepare a 10" small green stranded wire. Then install a circuit board connector on each end of this wire. Be sure to shrink 5/8" lengths of medium heat-shrink sleeving onto these connectors.
- () Push the circuit board connector on one end of the prepared green wire onto controller circuit board pin B. Route the free end of this wire down through chassis grommet CA. Then push the connector on this end of the wire onto audio circuit board pin M.

Refer to Pictorial 16-8 (Illustration Booklet, Page 47) for the following steps.

CAUTION: When you are directed to take a voltage measurement on a component in the following steps, be sure to touch the tip of your voltmeter probe only to the point indicated. If the probe should slip and accidentally short out a sensitive element, several components might become damaged to the extent that they would have to be replaced.

- () If there is a small jumper wire adjacent to IC U710, remove it for the following steps.
- () Make sure that all the plugs and pins on the circuit boards installed up to this point are connected as directed in the previous steps.
- () On the display circuit board, make sure the "special symbols" jumper is installed in the HI wire socket.
- () On the display circuit board, turn control R208 fully counterclockwise (as viewed from the rear of the chassis).
- () Connect the voltmeter common lead to the chassis.
- () Set your voltmeter to read +6 volts DC.
- () Reconnect the power supply and speaker to the Transceiver.
- () Turn the Transceiver on.
- () Use the positive voltmeter probe to measure the voltage at U710 pin 40. You should measure 4.75 to 5.25 volts DC. You should also measure this same voltage at P703 pin 1.

POSSIBLE CAUSES

1. Diode D709 or D711 incorrectly installed.
2. Transistor Q716 or Q717.
3. Capacitor C734, C735, C736, or C747.
4. Integrated circuit U714 or U715.

- () Measure the voltage at P701-5. You should measure 11.0 to 12.0 volts DC.

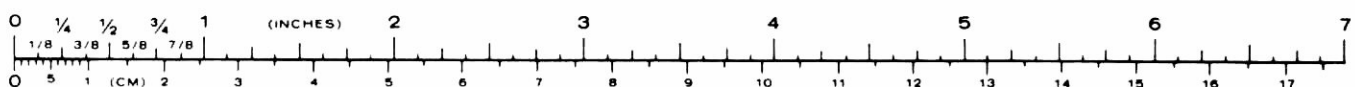

POSSIBLE CAUSES

1. Source voltage coming from the inverter.
2. Check the Schematic for controller circuit board 12-volt circuits.

Observe the three red LEDs at D703, D705, and D707. If any or all of these LEDs are lit, you may skip the following step (or steps) that refer to these LEDs. The purpose of this test is to assure that the unlock detection circuit associated with each LED is functional.

- () LED D703. If this LED is not lit, use a small screwdriver to carefully short the base (B) to the emitter (E) of transistor Q711. The LED should come on.
- () LED D705. To check D705, carefully short the base to the emitter of transistor Q713.
- () LED D707. To check D707, carefully short the base to the emitter of transistor Q715.

POSSIBLE CAUSES

1. Check the LED to make sure you have it correctly installed.
2. Check the referenced transistor for each diode, and its associated circuits.
3. Transistors Q709, Q712, and Q714 and associated components.

- () On the front panel, set the BAND switch to 80 and the MODE switch to NORM. The display should indicate L 3500.00.

NOTE: If the display indicated "bad CPU" in the above step, replace integrated circuit U710 before you continue. Contact the Heath Technical Assistance department. See the inside front cover of this Manual.

- () Turn the MODE switch through all of its remaining positions. Check to make sure the display indicates a "U" in the reverse mode and a "C" in both CW modes.

POSSIBLE CAUSES

1. Check for a problem on the display circuit board.
2. Check the wiring of the front panel MODE switch.

Temporarily unplug socket P805 from the BFO circuit board. Then measure the voltages at the pins of this socket as shown in the following chart. Rotate the MODE switch through all four positions to make sure each indicated voltage is present. Also check for the absence of the voltage indicated. NOTE: The voltages are approximate.

MODE Switch Setting	P805 PIN			
	1 (black wire)	2 (brown wire)	3 (red wire)	4 (orange wire)
Normal	+5	0	0	0
Reverse	0	+5	0	0
CW(W)	0	+5	+5	0
CW(N)	0	+5	0	+5

POSSIBLE CAUSES

1. Integrated circuit U702 or U709.
2. Mode switch.

- () Set the MODE switch to NORM.

- () On the front panel, depress the D⇌M button. Check the frequency display for a reading of 4000.00.
- () Depress the D→M button. The displayed frequency should not change.
- () Slowly turn the tuning knob clockwise. An arrow should appear to the left of the mode indicator, which indicates that the transmit frequency selected is out of the amateur band. As you continue to turn the knob, the frequency will increase in increments of 50 Hz. Then, as you turn the knob counterclockwise, the frequency should decrease in 50 Hz increments.
- () Depress the SPLIT pushbutton. A bar should appear to indicate a split mode of operation. NOTE: The arrow will disappear, if one was previously displayed.
- () Press the D⇌M button. An M should appear below the bar that appeared in the prior step. The M indicates that the frequency shown on the display is stored in the Transceiver's memory circuit, and is the frequency that will be used during transmitter operation when you use the Split Mode.
- () Turn the BAND switch through all the bands. Each band display should indicate the frequency of the lower band edge.
- () Turn the MODE switch to CW(W).
- () Press the TUNE button. A bar should appear above the MODE indicator to indicate that the Transceiver is in the transmit mode.
- () With the TUNE button still depressed, turn the SIDE TONE control clockwise until you can hear the sidetone.
- () Release the TUNE button.
- () Turn control R208, on the display circuit board, fully counterclockwise. Then hold your finger firmly in the metal insert of the Main Tuning knob. Adjust control R208 clockwise, as necessary, until the last two digits on the display disappear. Then adjust the control 1/8-turn further clockwise.
- () On the BFO circuit board, set LEVEL control R823, SSB control R834, and CW control R837 to the centers of their rotations.
- () On the front panel, make sure the IF SHIFT control is set to the center (detent position) of its rotation.
- () Temporarily remove the shielded cable from circuit board plug P802.
- () Connect the test lead of your frequency counter to plug P802 pin 2. Make sure the test lead does not touch against pin 1 of the plug and short to ground.
- () Set the MODE switch to NORM.
- () Set the BAND switch to 80.
- () Turn trimmer capacitor C816 until the frequency counter indicates approximately 8.8300 MHz.

POSSIBLE CAUSES

1. Incorrect trimmer at C816.
2. Diode D808 incorrectly installed.
3. Y801 and Y802 interchanged.
4. L803 incorrect value.

POSSIBLE CAUSES

1. Incorrect wiring.
2. VOX circuits on audio circuit board.
3. Sidetone circuits on audio circuit board.

- () Turn the MODE switch to REV.
- () Turn trimmer capacitor C822 until the frequency counter indicates 8.83145 MHz.

POSSIBLE CAUSES

1. Diodes D802 or D811 incorrectly installed.
2. L806 incorrect value.
3. Transistor Q803.

- () On the front panel, use a jumper wire to short the microphone connector PTT pin to chassis ground. (Refer to the inset drawing on the Pictorial.) Leave this wire connected until you are directed to disconnect it.
- () Measure the voltage at P803 pin 1. You should measure +12 volts DC. Set the voltmeter aside.

POSSIBLE CAUSES

1. Cable socket P803 installed backwards.
2. Diode D803 or D804 incorrectly installed.
3. Transistor Q808 or Q812.

- () Adjust SSB control R834 until the frequency counter indicates 8.83145 MHz.
- () Remove the jumper wire from the microphone connector.

POSSIBLE CAUSES

1. Resistor R835.
2. Transistor Q806, 807, or Q808.
3. Diode D803.

- () Turn the MODE switch to CW(W).
- () Press the TUNE button.
- () Adjust CW control R837 until the frequency counter indicates 8.8307 MHz.

POSSIBLE CAUSES

1. Resistor R838.
2. Transistors Q811, Q812.
3. Diodes D805, D806, D807.

- () Release the TUNE button.
- (*) Turn off the Transceiver, and set the MODE switch to NORM.
- () Disconnect the frequency counter from the BFO circuit board and reconnect the shielded cable to P802. Make sure the shielded lead is toward the top edge of the circuit board.
- () If your Transceiver appears to be operating properly up to this point, and you have the Keypad Accessory installed, solder the seven wires coming from the Keypad circuit board to the display circuit board. Then cut off any excess wire lengths.

NOTE: The BFO LEVEL control, R823, will be adjusted later.

SYNTHESIZER CIRCUIT BOARD INSTALLATION

Refer to Pictorial 16-9 (Illustration Booklet, Page 48) for the following steps.

- () Position the chassis upside-down as shown in the Pictorial.
- () Position all of the wires and cables away from the area of the chassis designated as "Synthesizer Circuit Board" on the Pictorial.
- () Refer to Detail 16-9A and mount the synthesizer circuit board to the chassis as shown. Use five 6-32 × 3/8" hex head screws at the indicated locations. Position the main and cable harnesses over the front edge of the circuit board as shown in the Pictorial. Be careful not to pinch any wires or cables between the circuit board and the chassis.
- () Refer to inset drawing #1 on the Pictorial and cut a grounding clip in half to make two clips. Use one of these clips in the next step. The other clip will be used later.

- () Refer again to Detail 16-9A and position the coil shield over the indicated end of the synthesizer circuit board. Then secure the shield and a grounding clip to the circuit board and chassis with two 6-32 × 1-1/2" black screws. Tighten the screws only until the shield starts to deform. Be sure the tab on the circuit board shield enters its corresponding hole in the coil shield. Then solder the tab to the coil shield as shown in the Pictorial. Also be sure to position the grounding clip so it is toward the front panel as shown in the Pictorial.
- () Refer to inset drawing #2 on the Pictorial and solder the bare wire coming from the synthesizer circuit board to the front of the coil shield in the area shown. Do not use too much heat or you may loosen the wire from the circuit board foil.

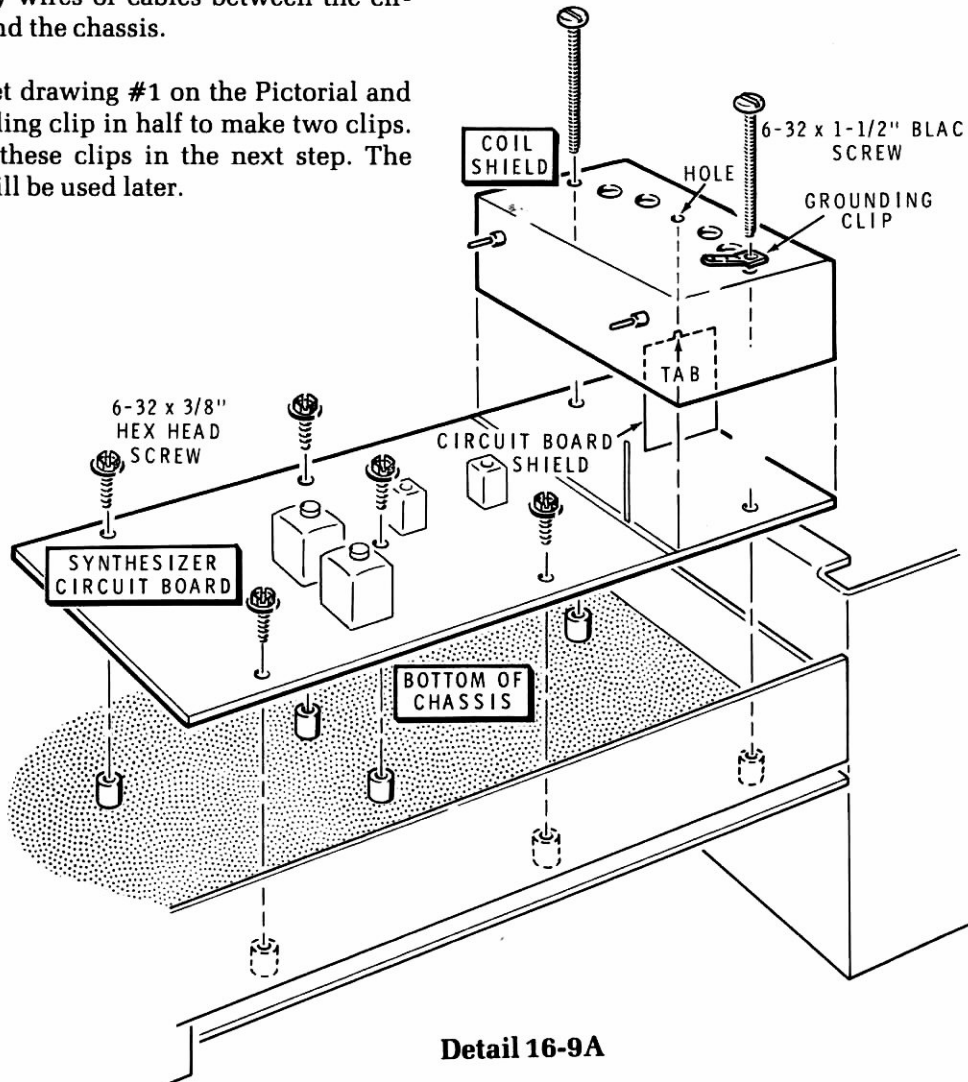

Heathkit®

- () Prepare a 1-3/4" small black stranded wire. Then refer to inset drawing #3 on the Pictorial and connect one end of the wire to resistor R111 (S-1) on the synthesizer circuit board. Solder the free end of this wire to the side of the synthesizer circuit board coil shield in the area shown.

Connect the circuit board connectors on the free ends of the wires coming from main harness breakout #13 to the synthesizer circuit board as follows:

- () Orange wire to pin 12B.
- () White-brown wire to pin D.
- () White-red wire to pin 8A.

Connect the circuit board connectors on the free ends of the wires coming from main harness breakout #14 to the synthesizer circuit board as follows:

- () White-gray wire to pin C.
- () White-blue wire to pin A.
- () White-green wire to pin B.
- () Push socket P103, coming from the cable harness, onto synthesizer circuit board plug P103. Be sure the inner lead of the shielded cable in this socket is at plug pin 1.

- () Connect the inner lead on the free end of the shielded cable coming from chassis hole BE to feedthrough capacitor C126 on the synthesizer circuit board coil shield (S-1). Solder the shield wires of this cable to the side of the coil shield in the area shown.

- () Push socket P102 on the free end of the shielded cable coming from chassis hole BF onto synthesizer circuit board plug P102. Be sure the inner lead of the shielded cable in this socket is at plug pin 1.

- () Push socket P105 on the free end of the shielded cable coming from chassis hole BG onto synthesizer circuit board plug P105. Be sure the inner lead of the shielded cable in this socket is at plug pin 1.

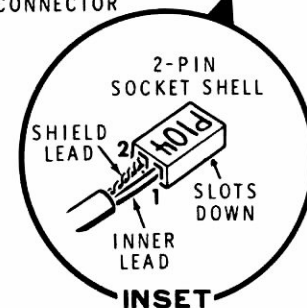
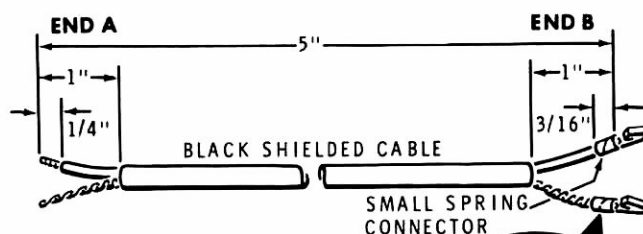

Detail 16-9B

- () Connect the inner lead on the free end of the shielded cable coming from chassis hole BH to feedthrough capacitor C315 on the high VCO assembly (S-2). Solder the shield wires of this cable to the side of the high VCO assembly in the area shown.
- () Refer to Detail 16-9B and prepare a 5" black shielded cable as shown. Then install small spring connectors on both wires at end B of this cable.
- () Locate a 2-pin socket shell and label it "P104". Then push the spring connectors on one end of the 5" cable into this socket shell as follows:

Inner lead into hole 1.

Shield wires into hole 2.

- () Push socket P104 on the end of the 5" cable onto synthesizer circuit board plug P104. Be sure the inner lead of the shielded cable in this socket is at plug pin 1.
- () Push socket P106 on the free end of the cable coming from grommet B onto synthesizer circuit board plug P106. Be sure the inner lead of the shielded cable in this socket is at plug pin 1.
- () Connect the inner lead at the free end of the 5" cable to the feedthrough insulator on the low VCO assembly (S-2) and the shield wires to the indicated area on the side of the low VCO assembly (where you soldered the other shield wires of the cables going to this insulator).

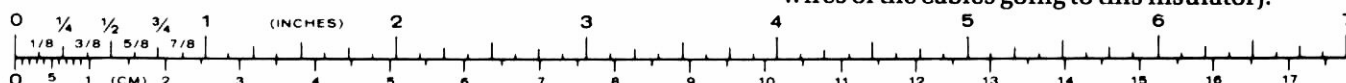

- () Push socket P107 on the free end of the cable coming from chassis hole BJ onto synthesizer circuit board plug P107. Be sure the shield lead of the shielded cable in this socket is at plug pin 2.
- () Connect the inner lead at the free end of the shielded cable coming from chassis hole BK (the cable that does not have a socket) to feedthrough capacitor C101 on the synthesizer circuit board coil shield (S-1). Solder the shield wires of this cable to the side of the coil shield in the area shown.
- () Push socket P101 on the free end of the shielded cable coming from chassis hole BK onto synthesizer circuit board plug P101. Be sure the inner lead of the shielded cable in this socket is at plug pin 1.
- () Connect the free end of the yellow wire coming from hole 8B on the synthesizer circuit board to feedthrough capacitor C183 on the synthesizer circuit board coil shield (S-1).
- () Apply labels from the label sheet to the synthesizer coil shield as shown in Detail 16-9C.
- () On the front panel, check and set all the pushbutton switches to their out positions.
- () Set the BAND switch to 80.
- () Set the MODE switch to NORM.
- () Connect the common lead of your voltmeter to a convenient bare chassis ground.
- () Turn on the Transceiver power. Do not turn the AF gain control further clockwise.
- () Set your voltmeter to read +12 volts DC.
- () Check circuit board connector pins 12B and 12C for +11.0 to +12.0 volts DC.

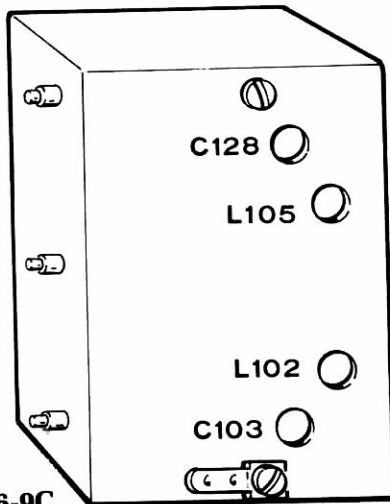

Detail 16-9C

Refer to Pictorial 16-10 (Illustration Booklet, Page 49) for the following steps.

- () Make sure that all previously installed circuit board connections have been made.

POSSIBLE CAUSES

1. Transistors Q118 or Q119 and associated circuits.
2. Open interconnecting wires.

- () Check for +7.6 to 8.6 volts DC at feedthrough capacitor C183.

POSSIBLE CAUSES

1. Interconnecting wiring.
2. Refer to the Schematic and locate the transistors and ICs fed by the +8-volt supply. Check these components and their associated circuits.

- () Turn the Transceiver off.

This completes the synthesizer circuit board voltage checks. You will make adjustments on this circuit board later.

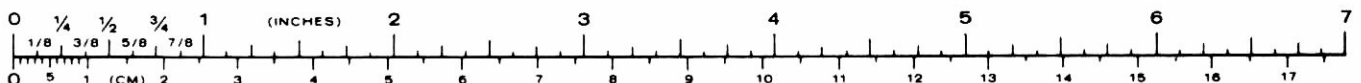

Heathkit®

IF CIRCUIT BOARD INSTALLATION

Refer to Pictorial 16-11 (Illustration Booklet, Page 50) for the following steps.

- () Position the chassis upside-down as shown in the Pictorial.
- () Position all of the wires and cables away from the area of the chassis designated as "IF circuit board" on the Pictorial.
- () Refer to Detail 16-11A and mount the IF circuit board and an IF shield to the chassis as shown. Use six 6-32 \times 3/8" hex head screws. Be careful not to pinch any wires or cables between the circuit board and the chassis. Also be sure to position the IF shield as shown in the Pictorial. This shield must **not** touch the nearby jumper wire on the circuit board, if one was installed in an earlier step.
- () Push socket P1106, coming from a front panel control, onto IF circuit board plug P1106. Be sure the orange wire in this socket is at plug pin 3.
- () Push socket P1107, coming from the cable harness, onto IF circuit board plug P1107. Be sure the inner lead of the shielded cable in this socket is at plug pin 1.
- () Push socket P1105 3-5, coming from the main harness, onto IF circuit board plug P1105 pins
- 3 through 5. Be sure the white-gray wire in this socket is at plug pin 5.
- () Push socket P1105 1&2, coming from the cable harness, onto IF circuit board plug P1105 pins 1 and 2. Be sure the shield wires in this socket are at plug pin 1.
- () Push socket P1104, coming from the main harness, onto IF circuit board plug P1104. Be sure the brown wire in this socket is at plug pin 1.
- () Push socket P1103 1-3, coming from the main harness, onto IF circuit board plug P1103 pins 1-3. Be sure the green wire in this socket is at plug pin 1.
- () Push socket P1103 4&5, coming from the main harness, onto IF circuit board plug P1103 pins 4 and 5. Be sure the yellow wire in this socket is at plug pin 5.
- () Push socket P1102, coming from the cable harness, onto IF circuit board plug P1102. Be sure the inner lead of the shielded cable in this socket is at plug pin 2.

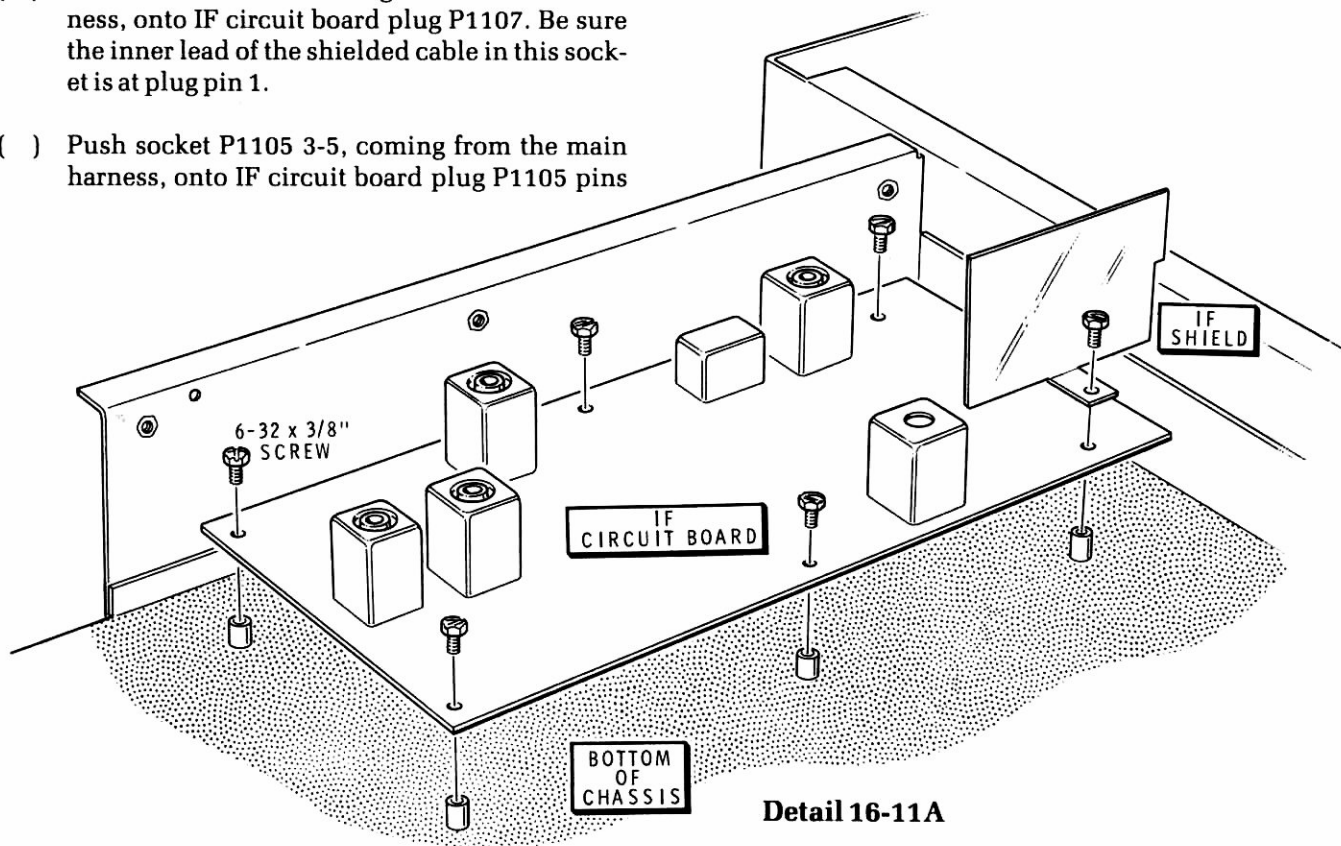

Detail 16-11A

- () Push socket P1101, coming from the main harness, onto IF circuit board plug P1101. Be sure the white-red wire in this socket is at plug pin 3.
- () Push the phono plug, coming from the cable harness, onto IF circuit board socket S1101.

Refer to Pictorial 16-12 (Illustration Booklet, Page 51) for the following steps.

- () Set the front panel MODE switch to NORM.
- () Set the BAND switch to 80M.
- () Set the RIT control to the center of its rotation (detent position).
- () Prepare two 1" small white solid wires. Use these wires in the next two steps.
- () Locate socket P410 coming from the main harness (see the Pictorial). Then insert a 1" white solid wire into holes 1 and 2 of this socket.
- () Locate socket P403 coming from the main harness. Then insert a 1" white solid wire into holes 2 and 3 of this socket.
- () Connect your voltmeter common lead to the chassis.
- () Turn the Transceiver on.
- () Set your voltmeter to read +6 volts DC.
- () Check P1106 pin 3 for +4.5 to +6.5 volts DC.

POSSIBLE CAUSES

1. Interconnect wiring.
2. Transistors Q108 through Q1112 and associated circuits.

- () Set your voltmeter to read +10 volts DC.
- () Check P1104 pin 2 for +8.5 to +9.5 volts DC.

POSSIBLE CAUSES

1. Transistor Q1107 and associated circuits.
2. Interconnect wiring.

- () Set your voltmeter to read +4 volts DC.
- () Carefully check IC U1101 pin 1 for +3.0 to +3.3 volts DC.

POSSIBLE CAUSES

1. AGC circuits.
2. Interconnect wiring.
3. IC U1101 and associated circuits.

- () On the display circuit board, turn ZERO control R203 clockwise until the meter pointer starts upscale. Then turn the control counterclockwise until the meter pointer just indicates 0.
- () On the display circuit board, turn SENS control R201 fully counterclockwise.
- () On the BFO circuit board, turn LEVEL control (R823) to the midpoint of its rotation.
- () Connect socket P802 (coming from the audio circuit board) into plug P802 on the BFO circuit board, if this has not already been done.
- () Set control R823 on the BFO circuit board to the center of its rotation, if this has not already been done.
- () Turn the AF GAIN control on the front panel fully clockwise. You should hear a hiss coming from the speaker.

POSSIBLE CAUSES

1. Sockets P1107 or P919 miswired.
2. U904 on the audio circuit board.
3. BFO injection level is too low.

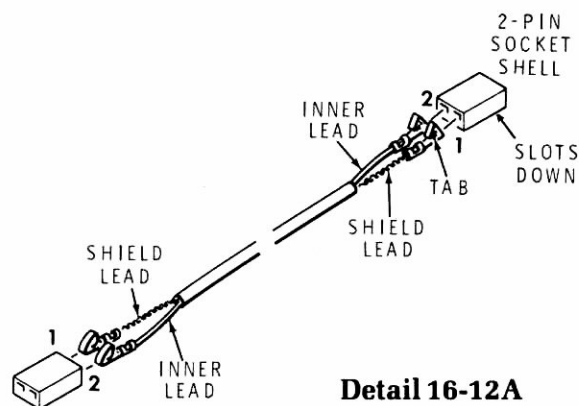

Detail 16-12A

IF ALIGNMENT

- () Prepare a 14" black shielded cable as shown in Detail 16-12A. Install small spring connectors and 2-pin socket shells on each end of this cable as shown. NOTE: This cable will be used as a test cable in the following steps.
- () Unplug socket P802 from the BFO circuit board. Then push the socket on one end of the test cable onto plug P802. Be sure the shield wires in this socket are at plug pin 1.
- () Unplug socket P1102 from the IF circuit board. Then push the socket on the free end of the test cable onto plug P1102. Be sure the shield wires in this socket are at plug pin 1.

NOTE: In the following steps, as you perform the adjustments, keep the front panel meter near mid-range. Adjust the display circuit board SENS control (R201) and the BFO circuit board LEVEL control (R823) as necessary to do this.

Adjust the following transformers in the order they are listed. Be sure to use the alignment tools provided to adjust the transformers. Adjust each coil for a maximum indication on the front panel meter. NOTE: If necessary, to keep the meter pointer mid-range, unplug the cable from BFO plug P802 and position the cable end near the plug.

- () 1. Transformer T1101.
- () 2. Transformer T1102.
- () 3. Transformer T1103.
- () 4. Transformer T1104.

Repeat Steps 1 through 4 at least two additional times.

- () Turn the SENS control on the display circuit board fully counterclockwise.
- () Reconnect the test cable socket to P802 on the BFO circuit board, if you had to unplug it, and set control R823 to the center of its rotation.
- () On the display circuit board, turn the SENS control clockwise for a full-scale meter reading.
- () Disconnect the shielded test cable from the BFO and IF circuit boards. Then reconnect the harness cables to these plugs. Be sure the shield wires in these sockets are at plug pins 1.
- () Be sure the RIT control on the front panel is at the center of its rotation (detent). Also be sure the MODE switch is at NORM.
- () Set your voltmeter to read +8 volts DC.
- () Measure the voltage at control R3B pin 1. Remember this voltage.
- () Use a length of wire to key the transmitter via the PTT pin on the front panel microphone connector (like you did earlier).
- () While the transmitter is keyed, adjust RIT CENTER control R1144 for the same voltage as you noted earlier (at control R3B pin 1).
- () Disconnect the wire from the microphone connector and set it aside.
- () Turn the Transceiver off and disconnect the voltmeter.
- () Remove the jumper wires from socket P403 and P410.

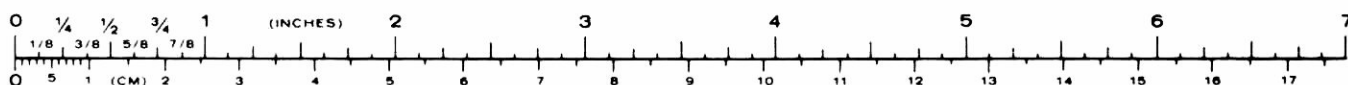

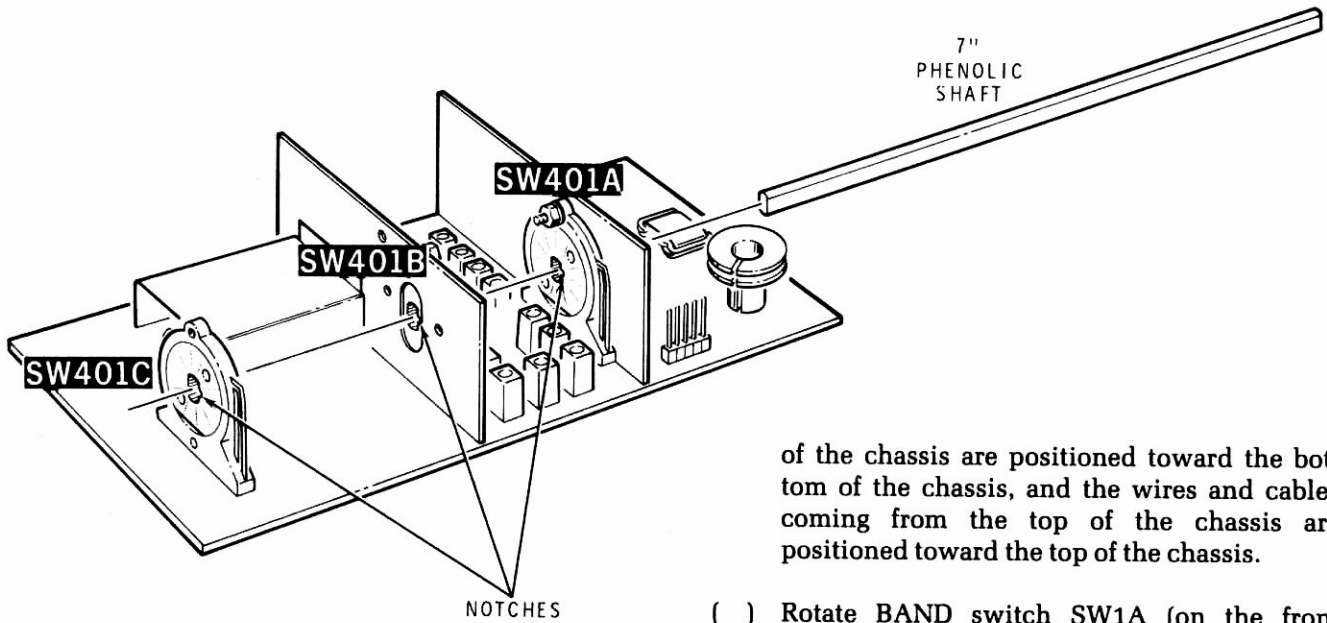

Detail 16-13A

RF CIRCUIT BOARD INSTALLATION

Refer to Pictorial 16-13 (Illustration Booklet, Page 52) for the following steps.

- () Position the chassis as shown in the Pictorial.
- () Remove the coil shield from the RF circuit board.
- () Position all of the wires and cables away from the area of the chassis designated as "RF circuit board" on the Pictorial. Be sure the harness wires and cables coming from the bottom

of the chassis are positioned toward the bottom of the chassis, and the wires and cables coming from the top of the chassis are positioned toward the top of the chassis.

- () Rotate BAND switch SW1A (on the front panel) fully counterclockwise (80 meters).
- () Use pliers to rotate the shaft of switch SW1B/SW1C fully counterclockwise.
- () Refer to Detail 16-13A and rotate the center portions of switches SW401A, B, and C so the notch is positioned as shown. Then slide the 7" shaft through the centers of these switches as shown.
- () Refer to Detail 16-13B and start two 6-32 × 1/8" setscrews into two shaft couplers. Then slide a coupler as far as possible onto each end of the 7" shaft.

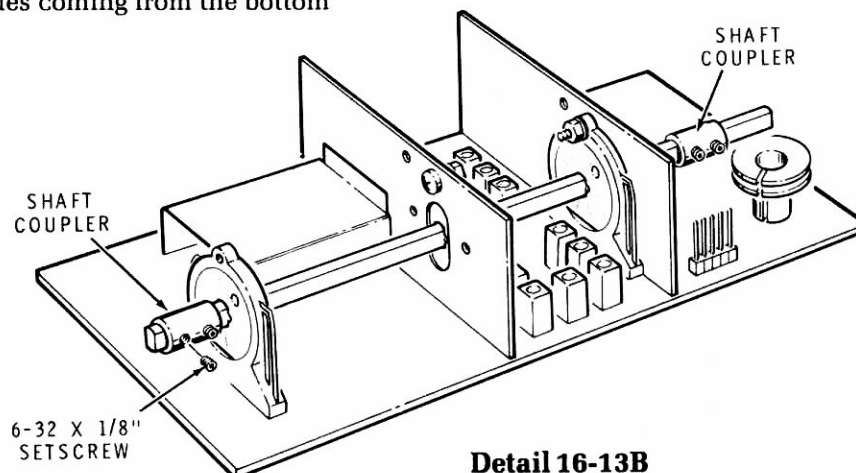

Detail 16-13B

Heathkit®

- () Refer to Detail 16-13C (Illustration Booklet, Page 53) and mount the RF circuit board to the chassis as shown. Use five 6-32 × 3/8" hex head screws, a #6 lockwasher, a 6-32 nut, and four long #6 solder lugs. Slide a 1-1/4" length of medium heat shrink sleeving onto each of the solder lugs.
- () Temporarily remove the knob from the shaft of switch SW1A.
- () Loosen the control nuts that secure switch SW1A to the front panel and switch SW1B/SW1C to the rear chassis.
- () Center the 7" shaft between the shafts of switches SW1A and SW1B/SW1C. Then slide the shaft coupler on one end of the 7" shaft half way onto the shaft of switch SW1A. Tighten the setscrew against the 7" shaft first; then tighten the other setscrew.
- () Use the following procedure to align the switches on the RF circuit board to SW1A:
 1. Connect an ohmmeter between circuit board plugs P410 pin 1 and P411 pin 1. NOTE: Do not connect the ohmmeter to sockets P410 and P411 on the harness.
 2. Rotate the body of switch SW1A (not the shaft) both directions and note that the ohmmeter shows a short circuit for a definite range.
 3. Rotate the body of switch SW1A so it is centered in the short circuit range, as indicated on the ohmmeter. Then tighten the control nut on switch SW1A.
 4. Reinstall the knob on the shaft of switch SW1A. Be sure the knob pointer is at 80.
- () Slide the remaining shaft coupler half way onto the shaft of switch SW1B/SW1C. Tighten the setscrew against the 7" shaft first; then tighten the other setscrew.
- () Tighten the control nut on switch SW1B/SW1C.
- () Push socket P411, coming from the main harness, onto RF circuit board plug P411. Be sure the green wire in this socket is at plug pin 1.
- () Push socket P408, coming from the main and cable harnesses, onto RF circuit board plug P408. Be sure the white-green wire in this socket is at plug pin 1.
- () Cut a 1" small bare wire. Then connect and solder one end of this wire to the shield wires of the shielded cable in socket P407 (coming from the main and cable harnesses). Be careful not to burn any of the other wires in this socket with your soldering iron.
- () Push socket P407 onto RF circuit board plug P407. Be sure the violet wires in this socket are at plug pins 1 and 2. Then solder the free end of the bare wire coming from this socket to the top of the RF circuit board shield in the area shown.
- () Remove the jumper wires in socket P403 coming from the main harness, if this has not already been done. Then push socket P403 onto RF circuit board plug P403. Be sure the gray wires in this socket are at plug pins 1, 2, and 3.
- () Cut a 1" small bare wire. Then connect and solder this wire to the shield wires of the shielded cable in socket P406 (coming from the cable harness). Use the same method as you did earlier.
- () Push socket P406 onto RF circuit board plug P406. Be sure the inner lead of the shielded cable in this socket is at plug pin 1. Then solder the free end of the bare wire coming from this socket to the top of the RF circuit board shield in the area shown.
- () Use the long #6 solder lugs along the bottom edge of the RF circuit board to secure the harnesses in place as shown in the Pictorial. Shorten these solder lugs as necessary.
- () Push socket P409, coming from the main harness, onto RF circuit board plug P409. Be sure the white-green wire in this socket is at plug pin 1.
- () Remove the jumper wire in socket P410 coming from the main harness, if this has not already been done. Then push socket P410 onto RF circuit board plug P410. Be sure the white-gray wire in this socket is at plug pin 4. Save the jumper wire for use later.
- () Push socket P405, coming from the main harness, onto RF circuit board plug P405. Be sure the red wire in this socket is at plug pin 1.

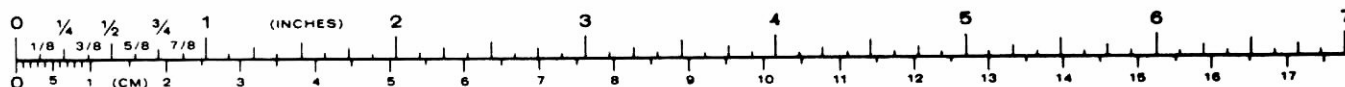

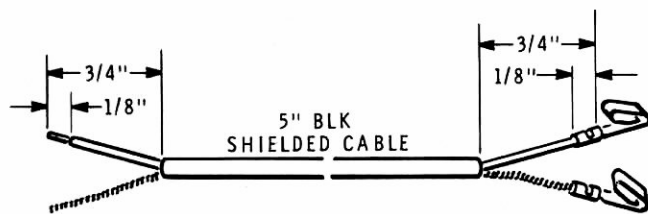

Detail 16-13D

- () Push socket P404, coming from the main harness, onto RF circuit board plug P404. Be sure the white-green wire in this socket is at plug pin 1.
- () Prepare a 5" black shielded cable as shown in Detail 16-13D. Then install small spring connectors on one end of this cable.
- () Push the spring connectors on the shielded cable into socket P401, coming from the main harness as follows:

Inner lead into hole 5.

Shield wires into hole 4.

- () Route the free end of the 5" shielded cable through grommet RE in the rear chassis. Then install small spring connectors on this end of the cable.
- () Unplug socket P554 from the filter circuit board. Then push the spring connectors on the free end of the 5" shielded cable into this socket as follows:

Inner lead into hole 3.

Shield wires into hole 2.

- () Push socket P554 back onto filter circuit board plug P554. Be sure the gray wire in this socket is at plug pin 1.
- () Push socket P401, coming from the main harness and a separate shielded cable, onto RF circuit board plug P401. Be sure the violet wires in this socket are at plug pins 1 and 2.
- () Use the long #6 solder lugs along the top of the RF circuit board to secure the harnesses in place as shown in the Pictorial. Shorten these solder lugs as necessary.

- () Push socket P402, coming from grommet RE in the rear chassis, onto RF circuit board plug P402. Be sure the orange wire in this socket is at plug pin 3.

Refer to Pictorial 16-14 (Illustration Booklet, Page 54) for the following steps.

- () On the front panel, set the MODE switch to CW(W), and the BAND switch to 80M.
- () Locate socket P651 coming from the rear chassis. Then install a short jumper wire between pins 2 and 3 of this socket. Use the jumper wire you set aside earlier.
- () Connect the common lead of your voltmeter to the chassis.
- () Set your voltmeter to read +15 volts DC.
- () Turn the Transceiver on.
- () Check circuit board plug P401 pins 1 and 2 for +12 to +13 volts DC.

POSSIBLE CAUSES

1. Interconnect wiring.
2. Diode D402 or D403 and associated circuits.

- () Check circuit board plug P402 pin 3 for +10 to +11 volts DC.

POSSIBLE CAUSES

1. Interconnect wiring.
2. Transistors Q403 and associated circuits.

- () On the front panel, depress the TUNE pushbutton.
- () Check circuit board plug P403 pins 1, 2, or 3 for +10.5 to +11.5 volts DC.

POSSIBLE CAUSES

1. Interconnect wiring.
2. TUNE switch wiring.
3. Transistor Q412 and associated circuits.
4. Diode D404.

- () Check circuit board plug P403 pin 5 for +8 to +9 volts DC. As you check for this voltage, release the front panel TUNE/REC pushbutton to REC. The voltage should drop to zero.

POSSIBLE CAUSES

1. Interconnect wiring.
2. Transistor Q403 or Q412 and their associated circuits.
3. TUNE/REC switch wiring.

- () Check circuit board plug P407 pin 1 for +12 to +13 volts DC.

POSSIBLE CAUSES

1. Interconnect wiring.
2. Diode D412.

- () Depress TUNE pushbutton.
- () Check circuit board plug P407 pin 3 for +8 to +9 volts DC.

POSSIBLE CAUSES

1. Interconnect wiring.
2. Integrated circuit U402 and associated circuit.

- () Check circuit board plug P405 pin 1 for +12.5 to +13.5 volts DC.

POSSIBLE CAUSES

1. Interconnect wiring.
2. Transistor Q405 and associated circuits.

- () Release the TUNE pushbutton.

SYNTHESIZER ALIGNMENT

Refer to Pictorial 16-15 (Illustration Booklet, Page 55) for the following steps.

- () Position the chassis as shown in the Pictorial.
- () Make sure that all previously installed circuit board connections have been made.
- () On the front panel, check and set all the pushbutton switches to their out (released) positions.
- () Set the BAND switch to 80.
- () Set the MODE switch to NORM.
- () Connect the common lead of your voltmeter to a convenient bare chassis ground.
- () On the synthesizer circuit board, set trimmer capacitors C103, C128, C117, C175, and C179 to mid-capacity (as shown in the inset drawing #1 on the Pictorial).

NOTES:

- A. In the following steps, when you are instructed to adjust for a certain voltage, connect the voltmeter to the point indicated, making sure the voltmeter ground is connected to a convenient bare chassis ground.
- B. At first, you may not be able to adjust to a given voltage; repeat the steps as directed until you are able to.
- C. If you do not obtain the correct indications in the following steps, refer to "Synthesizer Problems" in the Operation Manual.
- D. When you attempt to tune the Transceiver, do not allow a bright light to shine directly into the optical couplers.
- () Connect the voltmeter lead to test point PLL2 TUNE.
- () 1. Turn the MAIN TUNING knob on the front panel for a frequency of 4050.00.
- () 2. Adjust trimmer capacitor C103 for a +9-volt DC reading. NOTE: If you cannot obtain +9 volts at any setting of trimmer capacitor C103, adjust coil L102 as necessary until you can.

- () 3. Tune for a frequency of 3459.95. Adjust coil L102 for a +3 to +4-volt DC reading.
 - () Since the above adjustments interact with each other, repeat Steps 1, 2, and 3 until you obtain the correct voltage at each end of the band with no further adjustment. LED D705 on the controller circuit board should be off.
 - () Connect the voltmeter to test point PLL1 TUNE.
 - () 4. Tune for a frequency of 4050.00. Adjust trimmer C128 for +9 volts. NOTE: If you cannot obtain +9 volts at any setting of capacitor C128, adjust coil L105 as necessary until you can.
 - () 5. Tune for a frequency of 3450.00. Adjust coil L105 for +4 to +5 volts.
 - () Repeat Steps 4 and 5 until you obtain the correct voltage at each end of the band with no further adjustment. LED D703 on the controller circuit board should be off.
 - () Connect the voltmeter to the RF probe. Then connect the RF probe to the collector (C) of transistor Q107. See inset drawing #2 on the Pictorial.
 - () 6. Tune to a frequency of 3459.95. Adjust transformers T101 and T102 for the highest meter reading.
 - () 7. Tune to a frequency of 3460.00. Adjust trimmer C117 for a peak meter reading.
 - () Repeat Steps 6 and 7 several times.
 - () Connect the voltmeter RF probe to gate 1 (G1) of transistor Q112.
- NOTE: When you adjust coils L107 and L108 in the following steps, be careful not to exert any downward pressure on the slugs. Also do not turn the slugs more than two turns clockwise. Too much pressure, or turning the slug too far clockwise, could dislodge the slug from the transformer.
- () 8. Tune to a frequency of 3500.00. Adjust transformer T104 and coil L108 for a peak meter reading.
 - () 9. Tune to a frequency of 4000.00. Adjust transformer T103 and coil L107 for a peak meter reading.
 - () Repeat Steps 8 and 9 several times, until you notice no further improvement.
 - () Tune to the frequency (in Steps 8 and 9 above) that produced the lowest meter reading. Then adjust the **opposite** transformer (T103 or T104) until the meter readings are as close as possible. For example, if 3500.00 produced the lowest meter reading, adjust **T103** until both frequencies produce meter readings that are as close as possible. Do not go back and readjust T104.
 - () Connect the voltmeter RF probe to gate 2 (G2) of transistor Q111.
 - () 10. Turn the BAND switch to 12M. Adjust trimmer C175 for a peak meter reading.
 - () 11. Turn the BAND switch to 17M. Adjust trimmer C179 for a peak meter reading.
 - () In Steps 10 and 11, if trimmer C175 or C179 is at maximum capacitance (refer to inset drawing #1), adjust transformer T105 slug 1/4 turn clockwise and repeat the two steps. If either trimmer is at minimum capacitance, turn the slug of the T105 1/4 turn counterclockwise and repeat Steps 10 and 11.
 - () Turn the BAND switch to 20M.
 - () Connect the voltmeter RF probe to gate 1 (G1) of transistor Q112.
- NOTE: When you adjust coils L109 and L111 in the following steps, be careful not to exert any downward pressure on the slugs. Also do not turn the slugs more than two turns clockwise. Too much pressure, or turning the slug too far clockwise, could dislodge the slug from the coil.
- () 12. Tune to a frequency of 14.00000. Adjust coil L111 for a peak meter reading. NOTE: This coil may have two peaks. Use the peak that gives the highest indication.
 - () 13. Tune to a frequency of 14.35000. Adjust coil L109 for a peak meter reading. NOTE: This coil may have two peaks. Use the peak that gives the highest indication.
 - () Repeat Steps 12 and 13 several times.
 - () Turn the BAND switch to 10M.
 - () Turn the slugs in coils L112 and L113 four turns clockwise.

Heathkit®

- () 14. Tune to a frequency of 28.00000. Adjust coil **L113** for a peak meter reading.
- () 15. Tune to a frequency of 29.49995. Adjust coil **L112** for a peak meter reading.
- () Repeat Steps 14 and 15 several times.
- () Connect the voltmeter positive probe (not the RF probe) to test point **PLL3 TUNE**.
- () Turn the **AF GAIN** control fully clockwise. **NOTE:** When **PLL3** locks, in the following steps, you will hear an increase in the noise level.
- () 16. Turn the **BAND** switch to **30M**; then tune to a frequency of **10.00000**. Adjust trimmer **C309** (on the low band **VCO**) for +7 volts DC.
- () 17. Turn the **BAND** switch to **40M**; then tune to a frequency of **6.950000**. Adjust trimmer **C302** (on the low band **VCO**) for +4 volts DC.
- () 18. Turn the **BAND** switch to **80M**; then tune to a frequency of **3450.00**. Adjust trimmer **C305** (on the low band **VCO**) for +4 volts DC.
- () 19. Tune to a frequency of **4050.00** and check to make sure that **LED D707** on the controller circuit board is not lit. The voltmeter should indicate less than +9 volts DC. **NOTE:** If the indicated voltage exceeds +9 volts, adjust coil **L302** (on the low band **VCO**) clockwise 1/4 turn and repeat steps 16 through 18 again.
- () 20. Adjust coil **L352** (on the **HI VCO**) so the core is flush with the top of the coil form. Then turn the core 2 full turns counterclockwise.
- () 21. Turn the **BAND** switch to **12M**; then tune to a frequency of **24.84000**. Adjust trimmer **C362** (on the **HI VCO**) for +4 volts DC.
- () 22. Turn the **BAND** switch to **10M**; then tune to a frequency of **29.75000**. Check to make sure **LED D707** is not lit. The voltmeter should indicate less than +9 volts DC. **NOTE:** If the indicated voltage exceeds +9 volts, adjust coil **L352** (on the **HI VCO**) 1/4 turn clockwise and repeat Steps 21 and 22.
- () 23. Turn the **BAND** switch to **15M** and tune to a frequency of **20.95000**. Adjust trimmer **C352** (on the **HI VCO**) for +4 volts DC.
- () 24. Turn the **BAND** switch to **17M** and tune to a frequency of **18.01800**. Adjust trimmer **C355** (on the **HI VCO**) for +4 volts DC.
- () 25. Turn the **BAND** switch to **20M** and tune to a frequency of **13.95000**. Adjust trimmer **C358** (on the **HI VCO**) for +4 volts DC.
- () 26. Disconnect the voltmeter from the Transceiver.

CONTROLLER ALIGNMENT

- () Turn the **RIT** control on the front panel to the center of its rotation (detent position).
- () Connect a frequency counter to the collector of transistor **Q702**. Then adjust trimmer **C702** (on the controller circuit board) for an indication of **8.04 MHz**.
- () Connect the frequency counter to the collector of transistor **Q719**. Then adjust trimmer **C739** (on the controller circuit board) for an indication of **10.00 MHz**. **NOTE:** If you cannot obtain the correct indication, perform one of the following two steps:
 - A. If the **highest** indication you can obtain is less than **10 MHz**, carefully cut capacitor **C741** from the controller circuit board. Then adjust trimmer **C739** for **10.00 MHz**.
 - B. If the **lowest** indication you can obtain is greater than **10 MHz**, refer to inset drawing #1 and connect an additional **22 pF** ceramic capacitor across capacitor **C741** on the controller circuit board. Then adjust trimmer **C739** for **10.00 MHz**.
- () Disconnect the frequency counter from the Transceiver.
- () Cut a 3/4" length of small bare wire. Then form the wire into a loop as shown in inset drawing #2 and push it into the indicated wire sockets on the controller circuit board.
- () Turn the Transceiver off.

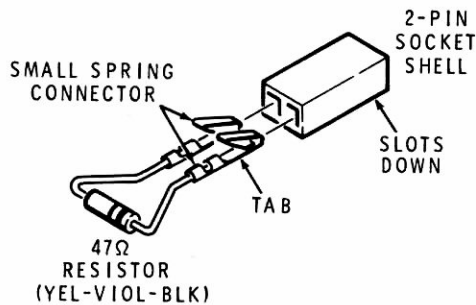

Detail 16-16A

Refer to Pictorial 16-16 (Illustration Booklet, Page 56) for the following steps.

- () Locate a 47 Ω, 1/2-watt resistor (yel-viol-blk). Then refer to Detail 16-16A and install a small spring connector on the end of each lead.
- () Refer again to Detail 16-16A and push the spring connectors on the resistor leads into the holes of a 2-pin socket shell as shown. NOTE: It does not matter which lead goes into which hole.
- () On the RF circuit board, unplug the socket from P402. Then rotate the socket and plug it back in so that only the orange wire is connected to its pin (pin 3).
- () Push the prepared 47 Ω (yel-viol-blk) resistor-socket assembly onto circuit board plug P402 pins 1 and 2.
- () Locate the previously assembled RF probe. Push the probe into P402 pin 1. Connect the probe ground clip to any convenient bare chassis ground.
- () Carefully remove the two screws from the RF circuit board coil shield, if this has not already been done. Then set the shield and the screws aside temporarily.

RF CIRCUIT BOARD ALIGNMENT

NOTE: In the following steps, you will align the bandpass filters in each of the eight bands. Although the filters are different, the procedure for each band is exactly the same:

- A. Set the front panel CW GAIN control fully clockwise.
 - B. Connect the positive voltmeter probe to the RF probe and start with your voltmeter on its lowest range. Then, as necessary, set the voltmeter to successively higher ranges.
 - C. Set the MODE switch to CW(W).
 - D. Adjust the two or three stated coils for the given band.
 - E. Adjust the band edge levels until they are equal.
- () Turn the Transceiver off, if this has not already been done. Then unplug the 6-pin accessory socket from the rear panel of the Transceiver. Wait at least 30 seconds; then reconnect the socket. This automatically resets the memory in the Transceiver to each band edge.
 - () Turn the Transceiver on.
 - () Turn the BAND switch to 80M.
 - () 1. Set the Main Tuning to 3500 kHz.
 - () 2. Depress the TUNE pushbutton.
 - () 3. Adjust coils L412 and L413 for the highest voltmeter reading.
 - () 4. Release the TUNE pushbutton.
 - () 5. With the M⇌D key, access the frequency 4000.00.
 - () 6. Depress the TUNE pushbutton.
 - () 7. Adjust coil L414 for a maximum voltage.

- () 8. Release the TUNE pushbutton.
- () 9. Use the M⇌D key to switch between 3500.00 and 4000.00. Note which frequency produces the lowest voltage on the voltmeter. Then use the M⇌D key to access the frequency that produced the lowest indication.
- () 10. Adjust coil L413 so that you obtain the same voltmeter indication at each frequency. NOTE: You may have to very slightly readjust coils L412 and L414 to obtain equal voltages. Check the voltages once again and make sure they are the same.
- () Repeat above Steps 1 through 10 until you obtain equal voltages on both ends of the band.

NOTE: You should have an indication of at least 2.5 volts RF at each end of the band in the above steps and in the following steps.

POSSIBLE CAUSES

1. No IF output.
2. BAND switch alignment (mechanical).
3. Synthesizer (PLL3) improperly aligned.
4. Problem on the RF circuit board. Refer to "In Case of Difficulty" in the Operation Manual.

NOTE: When you adjust the 40 through 12-meter bands in the following steps, be careful not to exert any downward pressure on the slugs. Also do not turn the slugs more than two turns clockwise. Too much pressure, or turning the slug too far clockwise, could dislodge the slug from the coil.

- () Turn the BAND switch to 40M. Then in the same manner as outlined in the preceding steps, adjust 40-meter bandpass coils L415, L416, and L417.
- () Turn the BAND switch to 30M. Then, in the same manner, adjust 30-meter bandpass coils L418, L419, and L421.
- () Turn the BAND switch to 20M. Then, in the same manner, adjust 20-meter bandpass coils L422, L423, and L424.
- () Turn the BAND switch to 17M. Then, in the same manner, adjust 17-meter bandpass coils L425 and L427.
- () Turn the BAND switch to 15M. Then, in the same manner, adjust 15-meter bandpass coils L428, L429, and L431.
- () Turn the BAND switch to 12M. Then, in the same manner, adjust 12-meter bandpass coils L432 and L434.
- () Turn the BAND switch to 10M. Then, in the same manner, adjust 10-meter bandpass coils L435, L436, and L437.
- () Turn the Transceiver off.
- () Unplug the 47-ohm resistor-socket and the RF probe from circuit board plug P402. Then reinstall socket P402 in its normal position on plug P402.
- () Unplug socket P802 from the BFO circuit board. Then connect the socket on one end of the previously assembled test cable onto plug P802. Be sure the shield wires in this socket are at plug pin 1.
- () Unplug socket P401 from the RF circuit board. Then turn this socket so that only the two violet wires are making contact with their circuit board pins.
- () Plug the free end of the test cable coming from plug P802 on the BFO circuit board onto plug P401 pins 4 and 5. Be sure the inner lead of the shielded cable in this socket is at plug pin 5.
- () Set the MODE switch to NORM, if this has not already been done.
- () Turn the Transceiver on.
- () Set the BAND switch to 40M and set the Main Tuning to 7300 kHz.
- () On the RF circuit board, adjust trimmer capacitor C406 and coil L405 for a null on the front panel meter.
- () Unplug the test cable from the BFO and RF circuit boards. Then reconnect the harness socket P401 to the RF circuit board in its normal position.

- () Connect a frequency counter to BFO circuit board P802 pin 2. Then adjust trimmer capacitor C816 until the frequency counter indicates 8.82855 MHz.
- () Set the MODE switch to REV. Then adjust trimmer capacitor C822 until the frequency counter indicates 8.83145 MHz.
- () Turn the Transceiver off.
- () Disconnect the frequency counter from the BFO circuit board. Then reconnect socket P802, coming from the cable harness, onto its plug on the BFO circuit board. Be sure the shield wires in this socket are at plug pin 1.
- () Refer to Detail 16-16B and reinstall the coil shield onto the RF circuit board. Use six #6 x 1/4" hex head sheet metal screws as shown.

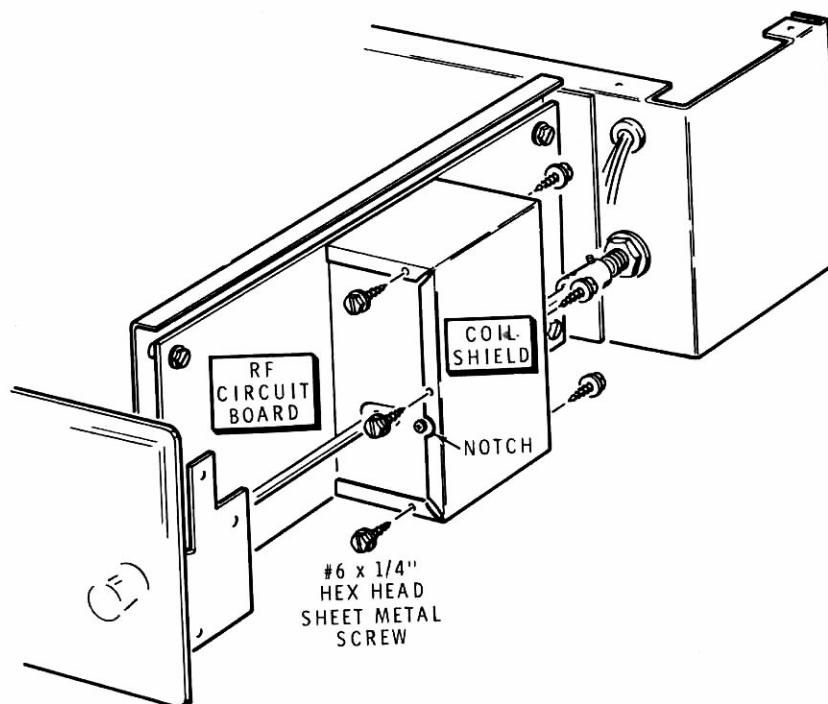

Detail 16-16B

Heathkit®

PA ASSEMBLY INSTALLATION

Refer to Pictorial 16-17 (Illustration Booklet, Page 57) for the following steps.

- () Position the power amplifier assembly near the chassis as shown in the Pictorial.
- () Locate socket P651 coming from the rear chassis. Then remove the short jumper wire that you installed in this socket earlier, if this has not already been done.
- () Push socket P651 onto ALC circuit board plug P651. Be sure the blue wire in this socket is at plug pin 1.
- () Push the phono plug, on the free end of the shielded cable coming from switch SW1C, into ALC circuit board socket S651.
- () Bend the two tabs on the large 4-pin plug, coming from the rear chassis, back as shown in Detail 16-17A. Then push the plug into rear panel hole HA until it locks into place. Be sure to position the plug so the two red wires are toward you as shown in the Pictorial.
- () Connect the free end of the white-brown wire, coming from rear chassis grommet RF, to phono socket J1 lug 1 (S-1).
- () Prepare an 11" small gray stranded wire and an 11" small violet stranded wire. Then install a small spring connector on one end of each wire.
- () Temporarily unplug socket P552 from the filter circuit board.
- () Push the spring connector on the end of the 11" gray wire into hole 2 of socket P552. Push the spring connector on the end of the 11" violet wire into hole 3 of this socket.
- () Push socket P552 back onto filter circuit board plug P552. Be sure the 11" violet wire that you just installed in this socket is at plug pin 3.
- () Loosely twist together (about 1 turn-per-inch) the 11" gray and violet wires coming from socket P552.
- () Connect the free end of the 11" gray wire to switch SW2 lug 1 (S-1) and the free end of the 11" violet wire to lug 2 (S-1).
- () Bend the two tabs on the small 6-pin socket, coming from the rear chassis, back as shown in Detail 16-17B. Then push the socket into rear panel hole HB until it locks into place. Be sure to position this socket so the "V" notch in one side is toward the nearby edge of the panel as shown in the Pictorial.

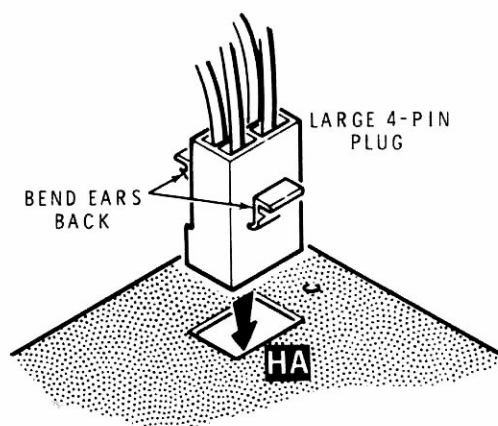

Detail 16-17A

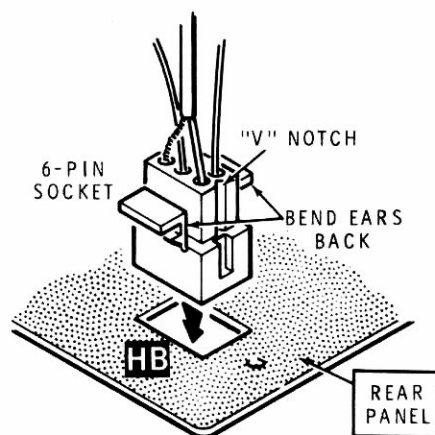

Detail 16-17B



- () Push the phono plug, on the free end of the shielded cable coming from the area of relay K1, into PA circuit board socket S1201.
- () Prepare the following wires:
 - 4" large white stranded
 - 4" large red stranded
 - 6" small gray stranded
 - 5" medium red stranded
 - 6" small black stranded
- () Connect the 4" large white stranded wire from rear chassis solder lug RD (S-1) to PA assembly solder lug HC (S-1). Use the top hole in solder lug RD. Be sure the wire that was previously connected to solder lug RD remains well soldered.
- () Insert one end of the 4" large red stranded and 5" medium red stranded wires into the bare wire loop at terminal strip RA lug 1 on the rear panel. Then crimp the loop around the wires and solder the connection. Be sure the connection is well soldered.
- () Slide three 5/16" long ferrite beads onto the free end of the medium red wire coming from rear chassis terminal strip RA. Then connect the free end of this wire to feedthrough capacitor C1225 on the PA assembly (S-2).
- () Temporarily tape up the end of the large red wire coming from rear chassis terminal strip RA so that it cannot touch anything. This wire will be connected later.
- () Install a small spring connector on one end of the 6" small gray wire.
- () Temporarily unplug socket P553 from the filter circuit board. Then push the spring connector on one end of the 6" gray wire into hole 5 of this socket.
- () Push socket P553 back onto filter circuit board plug P553. Be sure the red wire in this socket is at plug pin 1.
- () Connect the free end of the 6" gray wire, coming from socket P553, to feedthrough capacitor C1226 on the PA assembly (S-1).
- () Connect one end of the 6" small black stranded wire to rear panel solder lug RJ (S-1). Use the top hole in the solder lug and be sure the wire that was previously connected to this lug remains well soldered. Connect the free end of this wire to rear panel socket J1 lug 2 (S-1).
- () Push the phono plug, on the free end of the shielded cable coming from switch SW1B, into PA circuit board socket S1202.
- () Dress the wires and cables coming from the PA assembly as shown. Then install four cable ties around these wires and cables in the areas shown. NOTE: Do not include the four larger (2 red and 2 white) wires in the cable ties.



Heathkit®

Refer to Pictorial 16-18 (Illustration Booklet, Page 58) for the following steps.

() Reconnect the power supply to the Transceiver.

() Set the front panel controls and switches as follows:

BAND switch to 80M.

MODE switch to CW(W).

CW GAIN control fully counterclockwise.

() Turn the Transceiver on.

() On the front panel, depress the TUNE button.

() On the audio circuit board, adjust BIAS control R971 for exactly zero (0) on the front panel meter.

() Turn the Transceiver off.

() Remove the tape from the end of the large red wire coming from rear chassis terminal strip RA. Then temporarily tack solder a 10 Ω , 2-watt (brn-blk-blk) resistor from the end of this wire to feedthrough capacitor C1227 on the PA assembly. Be sure the resistor leads do not touch anything other than the connection points.

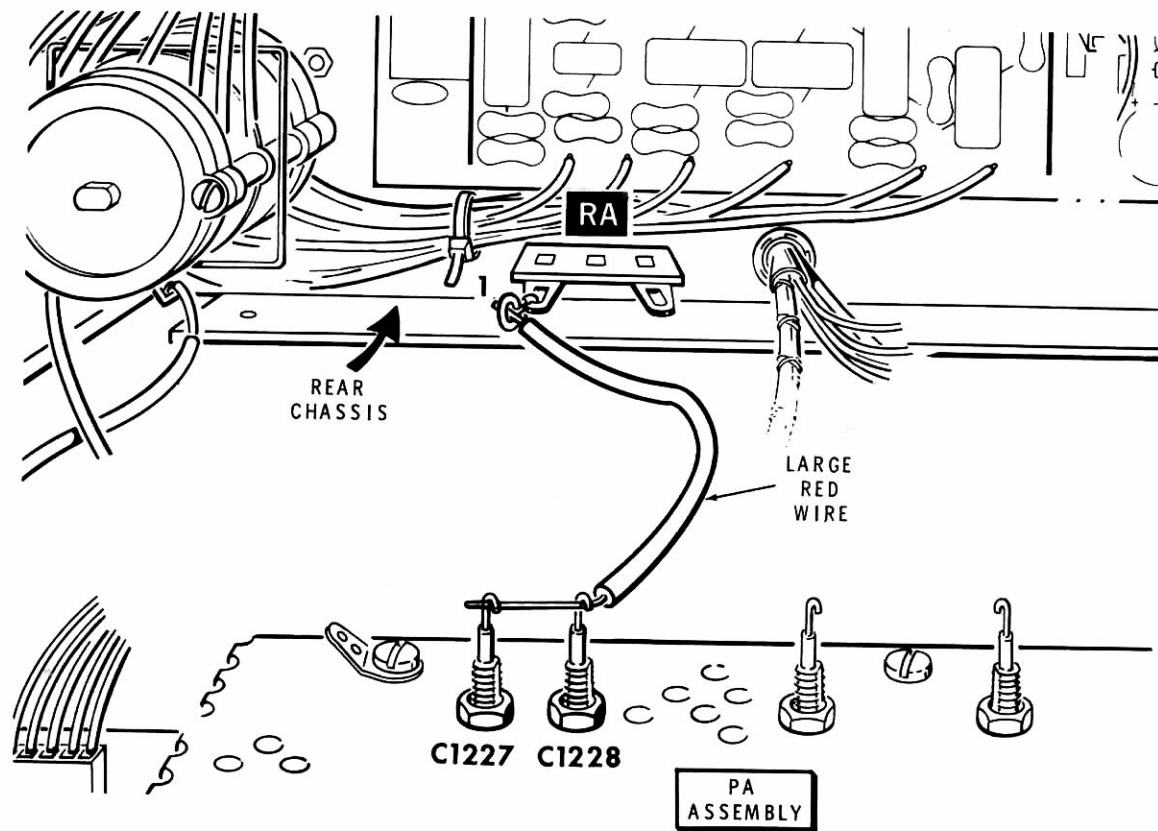

Detail 16-18A

NOTE: In the following step, if the voltage indicates a drop in the pointer, switch the voltmeter leads, or switch to the opposite meter mode.

- () Turn the Transceiver on.
- () Set your voltmeter to read 15 VDC.
- () Connect the common voltmeter lead to the chassis.
- () Touch the positive voltmeter lead to terminal strip RA lug 1. Write down the meter indication.
- () Press the TUNE pushbutton. Then touch the positive voltmeter lead to feedthrough capacitor C1227. After the power stabilizes (about 30 seconds), adjust BIAS control R1215 on the power amplifier circuit board until the voltmeter indicates exactly 2 volts less than it did in the above step (at terminal strip RA lug 1). Then release the TUNE pushbutton.
- () Turn the Transceiver off and disconnect the test resistor.

NOTE: Be careful not to break the feedthrough capacitors when you connect wires to them in the following steps.

- () Remove an additional 3/8" of insulation (total 5/8") from the free end of the large red wire coming from rear chassis terminal strip RA. Then refer to Detail 16-18A and connect and solder this end of the wire to feedthrough capacitors C1227 and C1228 on the PA assembly.
- () Refer to Pictorial 16-19 and position the PA assembly against the rear of the chassis as shown. Then secure the assembly to the chassis with four 6-32 × 3/8" hex head screws. Be careful not to pinch any wires between the PA assembly and the chassis. Also make sure none of the bare ends of the red wires touch the chassis.

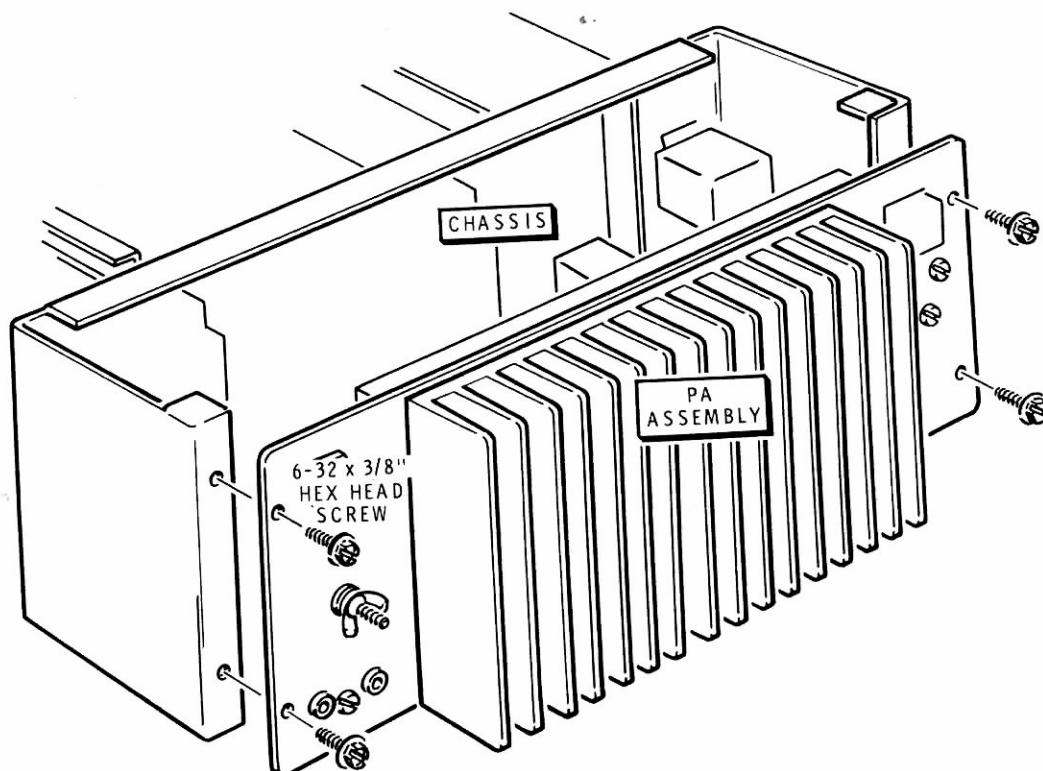

PICTORIAL 16-19

Heathkit[®]

Refer to Pictorial 16-20 (Illustration Booklet, Page 59) for the following steps.

- () Connect the output of your Transceiver to a wattmeter capable of measuring at least 100 watts of power.
- () Connect the output of the wattmeter to a 50-ohm dummy load capable of dissipating 100 watts of power.
- () Turn the Transceiver on. Be sure the front panel controls are at 80M, and CW(W).
- () Turn the FWD control (R658) on the ALC circuit board fully clockwise.
- () Turn the CW GAIN control, on the front panel, fully counterclockwise.
- () Turn the BFO LEVEL control (R823) on the BFO circuit board to the center of its rotation.
- () Push the TUNE pushbutton.
- () Turn the CW GAIN control clockwise for a maximum indication on the wattmeter. NOTE: The output power should not exceed 100 W. Also, the meter on the front panel should indicate full scale. If you do not have the correct indications, refer to "In Case of Difficulty" in the Operation Manual.
- () On the ALC circuit board, adjust FWD control R658 counterclockwise for 100 watts output.
- () Watch the wattmeter and adjust BFO LEVEL control R823 counterclockwise until you obtain 95 watts of output.
- () Adjust FWD control R658, on the ALC circuit board, counterclockwise until you obtain 100 watts of output. Then release the TUNE pushbutton.
- () Push the TUNE pushbutton. Then readjust coils T1101 and T1102, on the IF circuit board, for a peak indication on the wattmeter.
- () Release the TUNE pushbutton.
- () Turn the Transceiver off.

- () Set the front panel MODE switch to NORM.
- () Connect the RF probe to ALC circuit board socket S654.
- () Turn the Transceiver on.
- () On the front panel, use a length of wire to short the microphone connector PTT pin to the chassis (like you did earlier).
- () 1. On the audio circuit board, turn NULL control R931 for a dip or a null as shown on the voltmeter.
- () 2. Set the MODE switch to REV.
- () 3. Again adjust control R931 for a null as shown on the voltmeter.
- () 4. Set the MODE switch to NORM.

NOTE: Repeat Steps 1 through 4 until you have obtained the best possible null.

- () Turn the Transceiver off and disconnect the RF probe from the ALC circuit board socket.
- () Unplug the power supply and disconnect the power supply and speaker from the Transceiver.

NOTE: A jumper wire on the display circuit board allows you to set the intensity of the special symbols on the left side of the display to bright, dim, or off. If you wish to change the intensity of the special symbols, perform one of the following steps:

- A. If you want to have the intensity of the special symbols the same as the frequency display, set the jumper to HI.
- B. If you want the special symbols to have less intensity than the frequency display, set the jumper to MED.
- C. To completely disable the special symbols, set the jumper to OFF.

This completes the Tests and Adjustments of your Transceiver; proceed to "Final Assembly."

FINAL ASSEMBLY

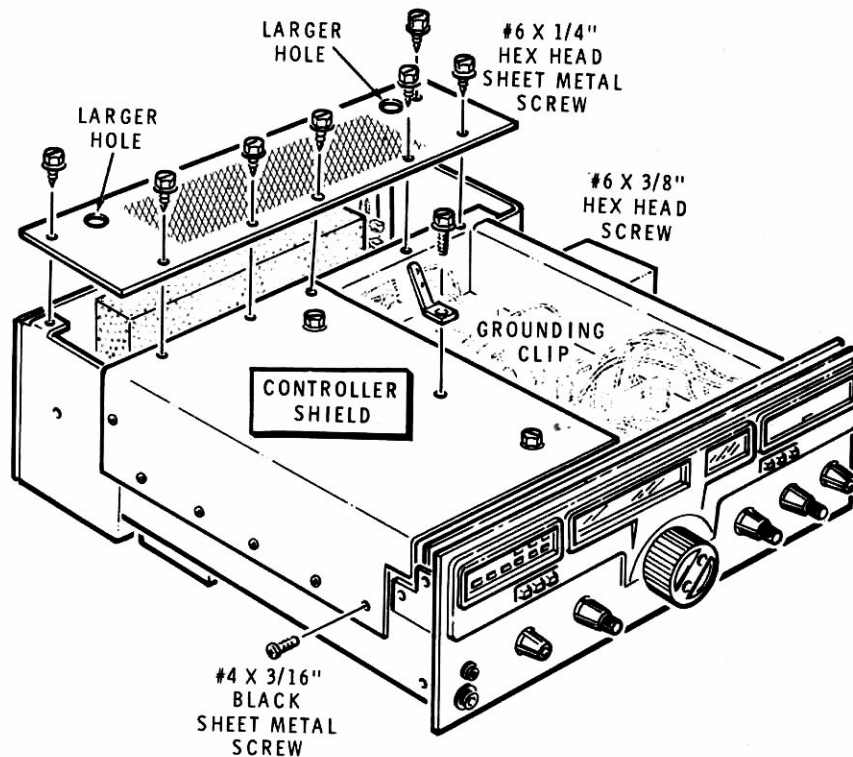

PICTORIAL 17-1

Refer to Pictorial 17-1 for the following steps.

- () Position the chassis as shown in the Pictorial.
- () Position the controller shield on the chassis as shown. Then secure the shield to the left side of the chassis with six #4 × 3/16" black sheet metal screws. Use three #6 × 3/8" hex head sheet metal screws and a prepared grounding clip (set aside earlier) to secure the shield to the center shield. Be sure to mount the grounding clip under the center screw. Be sure to position the clip as shown.
- () Mount a filter circuit board shield to the top of the rear chassis as shown. Be careful not to pinch any wires or cables. Use seven #6 × 1/4" hex head sheet metal screws. Be sure to position the shield as shown (note the locations of the larger holes in the shield).

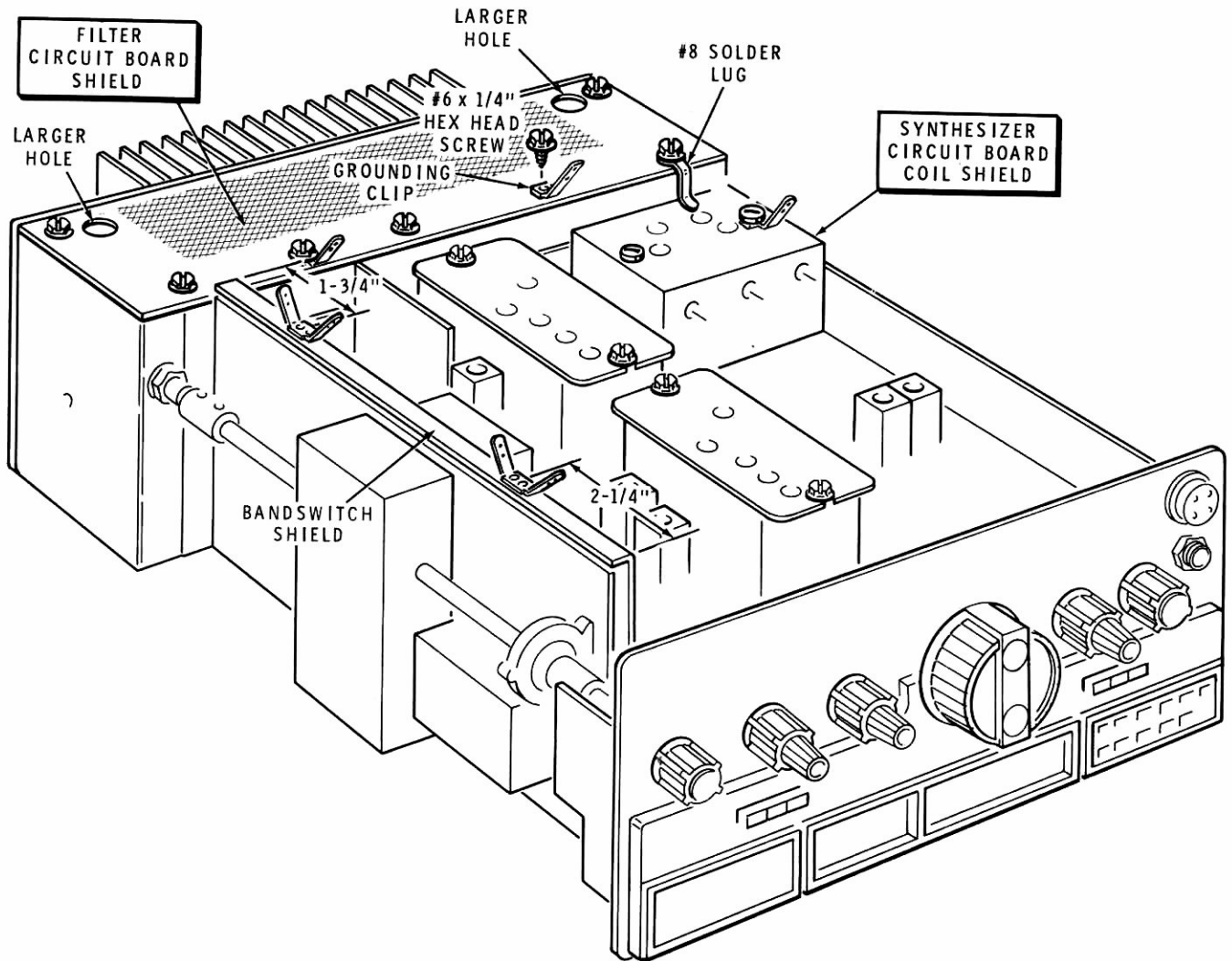

PICTORIAL 17-2

Refer to Pictorial 17-2 for the following steps.

- () Position the chassis upside-down as shown in the Pictorial.
- () Refer to Detail 17-2A and cut the grounding clip in half to make two clips.
- () Mount a filter circuit board shield to the rear chassis as shown. Be careful not to pinch any wires or cables between the shield and the chassis. Use seven #6 × 1/4" hex head sheet metal screws, two prepared grounding clips, and a #8 solder lug. Position the clips so they face the front panel as shown.
- () Bend the #8 solder lug so it touches the top of the synthesizer circuit board coil shield. Then solder the lug to the coil shield.
- () Solder two grounding clips to the edge of the bandswitch shield in the areas shown. Do not cut these grounding clips in half.

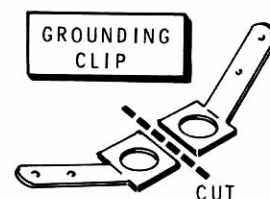

Detail 17-2A

Refer to Pictorial 17-3 (Illustration Booklet, Page 60) for the following steps.

- () Mount the bezel onto the chassis as shown. Use four 6-32 \times 3/16" flat head screws. NOTE: The bezel may be mounted either way onto the chassis.
- () Refer to Detail 17-3A Part A and mount a foot on the cabinet bottom at DA with 6-32 \times 1/2" black phillips head hardware and a #6 flat washer.
- () Similarly, install feet on the cabinet bottom at DB.

NOTE: Perform only one of the next two steps. If you wish to have your Transceiver rest in a horizontal attitude on your bench, perform the next step. If you wish to have the front of your Transceiver tilted upward a small amount, skip the next step and follow the instructions in the second and third steps.

- () Similarly to the preceding two steps, install feet on the cabinet bottom at DC and DD. NOTE: The two 6-32 \times 1-3/8" screws and two black nylon spacers will not be used.
- () Refer to Part B of the Detail and slide a #6 flat washer onto a 6-32 \times 1-3/8" screw, followed by a foot and a black nylon spacer. Secure the foot and spacer to the cabinet bottom at DC with a #6 lockwasher and a 6-32 nut.
- () Similarly, mount a foot and a black nylon spacer on the cabinet bottom at DD.

PART A

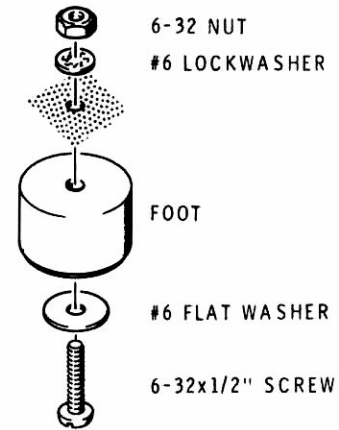

PART B

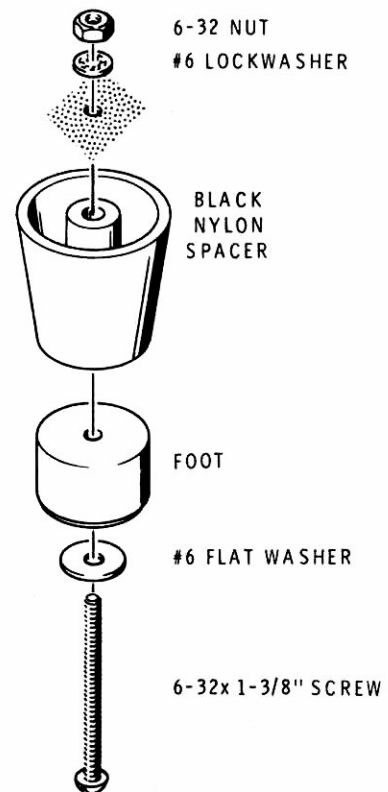

Detail 17-3A

Heathkit®

- () Carefully peel the backing paper from the blue and white label. Then press the label onto the top of the controller shield in the area shown. Be sure to refer to the Model and Series numbers on this label in any correspondence you have with the Heath Company. This assures you that you will receive the most complete and up-to-date information in return.
- () If you have the Keypad Accessory installed in your Transceiver, carefully peel the backing paper from the blue and white label that is included with that kit. Then press the label onto the top of the controller shield in the area shown.
- () Position the chassis of your Transceiver into the cabinet bottom as shown in the Pictorial. Be sure to line up the holes in the side of the cabinet bottom with the holes in the chassis.
- () Position the cabinet top down onto the flanges of the cabinet bottom. After you align the side holes, secure cabinet to the chassis at DE, DF, DG, and DH with four 6-32 \times 3/8" black philips head screws.

This completes the assembly and alignment of your Transceiver. Proceed to "Operation" in the separate Operation Manual.

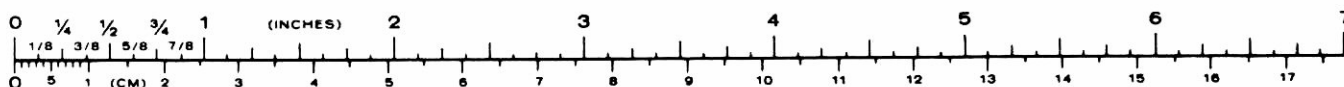

CUSTOMER SERVICE

REPLACEMENT PARTS

Please provide complete information when you request replacements from either the factory or Heath Electronic Centers. Be certain to include the **HEATH** part number exactly as it appears in the parts list.

ORDERING FROM THE FACTORY

Print all of the information requested on the parts order form furnished with this product and mail it to Heath. For telephone orders (parts only) dial 616 982-3571. If you are unable to locate an order form, write us a letter or card including:

- Heath part number.
- Model number.
- Date of purchase.
- Location purchased or invoice number.
- Nature of the defect.
- Your payment or authorization for COD shipment of parts not covered by warranty.

Mail letters to: Heath Company
Benton Harbor
MI 49022
Attn: Parts Replacement

Retain original parts until you receive replacements. Parts that should be returned to the factory will be listed on your packing slip.

OBTAINING REPLACEMENTS FROM HEATH ELECTRONIC CENTERS

For your convenience, "over the counter" replacement parts are available from the Heath Electronic Centers listed in your catalog. Be sure to bring in the original part and purchase invoice when you request a warranty replacement from a Heath Electronic Center.

TECHNICAL CONSULTATION

Need help with your kit? — Self-Service? — Construction? — Operation? — Call or write for assistance. you'll find our Technical Consultants eager to help with just about any technical problem except "customizing" for unique applications.

The effectiveness of our consultation service depends on the information you furnish. Be sure to tell us:

- The Model number and Series number from the blue and white label.
- The date of purchase.
- An exact description of the difficulty.
- Everything you have done in attempting to correct the problem.

Also include switch positions, connections to other units, operating procedures, voltage readings, and any other information you think might be helpful.

Please do not send parts for testing, unless this is specifically requested by our Consultants.

Hints: Telephone traffic is lightest at midweek — please be sure your Manual and notes are on hand when you call.

Heathkit Electronic Center facilities are also available for telephone or "walk-in" personal assistance.

REPAIR SERVICE

Service facilities are available, if they are needed, to repair your completed kit. (Kits that have been modified, soldered with paste flux or acid core solder, cannot be accepted for repair.)

If it is convenient, personally deliver your kit to a Heathkit Electronic Center. For warranty parts replacement, supply a copy of the invoice or sales slip.

If you prefer to ship your kit to the factory, attach a letter containing the following information directly to the unit:

- Your name and address.
- Date of purchase and invoice number.
- Copies of all correspondence relevant to the service of the kit.
- A brief description of the difficulty.
- Authorization to return your kit COD for the service and shipping charges. (This will reduce the possibility of delay.)

Check the equipment to see that all screws and parts are secured. (Do not include any wooden cabinets or color television picture tubes, as these are easily damaged in shipment. Do not include the kit Manual.) Place the equipment in a strong carton with at least **THREE INCHES** of *resilient* packing material (shredded paper, excelsior, etc.) on all sides. Use additional packing material where there are protrusions (control sticks, large knobs, etc.). If the unit weighs over 15 lbs., place this carton in another one with 3/4" of packing material between the two.

Seal the carton with reinforced gummed tape, tie it with a strong cord, and mark it "Fragile" on at least two sides. Remember, the carrier will not accept liability for shipping damage if the unit is insufficiently packed. Ship by prepaid express, United Parcel Service, or insured Parcel Post to:

Heath Company
Service Department
Benton Harbor, Michigan 49022



HEATH COMPANY • BENTON HARBOR, MICHIGAN
THE WORLD'S FINEST ELECTRONIC EQUIPMENT IN KIT FORM

LITHO IN U.S.A.