

# HEATHKIT<sup>®</sup> MANUAL

*for the*

## **LOW-POWER CW TRANSCEIVER**

Model HW-8

1-595-1754-06



HEATH COMPANY • BENTON HARBOR, MICHIGAN

## HEATH COMPANY PHONE DIRECTORY

The following telephone numbers are direct lines to the departments listed:

Kit orders and delivery information ..... (616) 982-3411  
Credit ..... (616) 982-3561  
Replacement Parts ..... (616) 982-3571

### Technical Assistance Phone Numbers

8:00 A.M. to 12 P.M. and 1:00 P.M. to 4:30 P.M., EST, Weekdays Only  
Audio ..... (616) 982-3310  
Amateur Radio ..... (616) 982-3296  
Test Equipment, Weather Instruments and  
Home Clocks ..... (616) 982-3315  
Television ..... (616) 982-3307  
Aircraft, Marine, Security, Scanners, Automotive,  
Appliances and General Products ..... (616) 982-3496  
Computers — Hardware ..... (616) 982-3309  
Computers — Software:  
Operating Systems, Languages, Utilities ..... (616) 982-3860  
Application Programs ..... (616) 982-3884

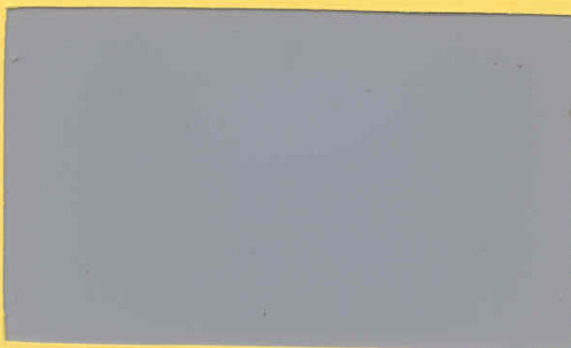

## YOUR HEATHKIT 90-DAY LIMITED WARRANTY

### Consumer Protection Plan for Heathkit Consumer Products

Welcome to the Heath family. We believe you will enjoy assembling your kit and will be pleased with its performance. Please read this Consumer Protection Plan carefully. It is a "LIMITED WARRANTY" as defined in the U.S. Consumer Product Warranty and Federal Trade Commission Improvement Act. This warranty gives you specific legal rights, and you may also have other rights which vary from state to state.

#### Heath's Responsibility

**PARTS** — Replacements for factory defective parts will be supplied free for 90 days from date of purchase. Replacement parts are warranted for the remaining portion of the original warranty period. You can obtain warranty parts direct from Heath Company by writing or telephoning us at (616) 982-3571. And we will pay shipping charges to get those parts to you . . . anywhere in the world.

**SERVICE LABOR** — For a period of 90 days from the date of purchase, any malfunction caused by defective parts or error in design will be corrected at no charge to you. You must deliver the unit at your expense to the Heath factory, any Heath Zenith Computers and Electronics center (units of Veritechnology Electronics Corporation), or any of our authorized overseas distributors.

**TECHNICAL CONSULTATION** — You will receive free consultation on any problem you might encounter in the assembly or use of your Heathkit product. Just drop us a line or give us a call. Sorry, we cannot accept collect calls.

**NOT COVERED** — The correction of assembly errors, adjustments, calibration, and damage due to misuse, abuse, or negligence are not covered by the warranty. Use of corrosive solder and/or the unauthorized modification of the product or of any furnished component will void this warranty in its entirety. This warranty does not include reimbursement for inconvenience, loss of use, customer assembly, set-up time, or unauthorized service.

This warranty covers only Heath products and is not extended to other equipment or components that a customer uses in conjunction with our products.

**SUCH REPAIR AND REPLACEMENT SHALL BE THE SOLE REMEDY OF THE CUSTOMER AND THERE SHALL BE NO LIABILITY ON THE PART OF HEATH FOR ANY SPECIAL, INDIRECT, INCIDENTAL OR CONSEQUENTIAL DAMAGES, INCLUDING BUT NOT LIMITED TO ANY LOSS OF BUSINESS OR PROFITS, WHETHER OR NOT FORESEEABLE.**

Some states do not allow the exclusion or limitation of incidental or consequential damages, so the above limitation or exclusion may not apply to you.

#### Owner's Responsibility

**EFFECTIVE WARRANTY DATE** — Warranty begins on the date of first consumer purchase. You must supply a copy of your proof of purchase when you request warranty service or parts.

**ASSEMBLY** — Before seeking warranty service, you should complete the assembly by carefully following the manual instructions. Heathkit service agencies cannot complete assembly and adjustments that are customer's responsibility.

**ACCESSORY EQUIPMENT** — Performance malfunctions involving other non-Heath accessory equipment, (antennas, audio components, computer peripherals and software, etc.) are not covered by this warranty and are the owner's responsibility.

**SHIPPING UNITS** — Follow the packing instructions published in the assembly manuals. Damage due to inadequate packing cannot be repaired under warranty.

If you are not satisfied with our service (warranty or otherwise) or our products, write directly to our Director of Customer Service, Heath Company, Benton Harbor MI 49022. He will make certain your problems receive immediate, personal attention.

# Heathkit<sup>®</sup> Manual

for the

## LOW-POWER CW TRANCEIVER Model HW-8

595-1754-10



HEATH COMPANY  
BENTON HARBOR, MICHIGAN 49022

Copyright © 1975  
Heath Company  
All Rights Reserved  
Printed in the United States of America



## TABLE OF CONTENTS

<p>INTRODUCTION . . . . . 3</p> <p>ASSEMBLY NOTES . . . . . 5</p> <p style="padding-left: 20px;">Soldering Instructions . . . . . 6</p> <p>CIRCUIT BOARD</p> <p style="padding-left: 20px;">Parts List . . . . . 9</p> <p style="padding-left: 20px;">Step-by-Step Assembly . . . . . 17</p> <p style="padding-left: 20px;">Circuit Board Wiring . . . . . 37</p> <p>CHASSIS</p> <p style="padding-left: 20px;">Parts List . . . . . 43</p> <p style="padding-left: 20px;">Step-by-Step Assembly . . . . . 48</p> <p style="padding-left: 40px;">Rear Panel Parts Mounting . . . . . 48</p> <p style="padding-left: 40px;">Mounting and Wiring Rear Panel . . . . . 48</p> <p style="padding-left: 40px;">Mounting Panel/Circuit Board Assembly . . . . . 49</p> <p style="padding-left: 40px;">Chassis Parts Mounting and Wiring . . . . . 50</p> <p style="padding-left: 40px;">Front Panel Mounting . . . . . 54</p> <p style="padding-left: 40px;">Installing Knobs . . . . . 55</p> <p style="padding-left: 40px;">Final Parts Mounting and Wiring . . . . . 56</p> <p style="padding-left: 40px;">Preparing Power Cable . . . . . 57</p> <p style="padding-left: 40px;">Preparing Dummy Load . . . . . 57</p> <p>INITIAL TESTS . . . . . 59</p>	<p>ALIGNMENT . . . . . 61</p> <p>FINAL ASSEMBLY . . . . . 65</p> <p>OPERATION . . . . . 67</p> <p>IN CASE OF DIFFICULTY . . . . . 69</p> <p style="padding-left: 20px;">Visual Checks . . . . . 70</p> <p style="padding-left: 20px;">Precautions for Bench Testing . . . . . 70</p> <p style="padding-left: 40px;">Troubleshooting Charts . . . . . 71</p> <p>SPECIFICATIONS . . . . . 73</p> <p>CIRCUIT DESCRIPTION . . . . . 75</p> <p>CIRCUIT BOARD X-RAY VIEWS . . . . . 78</p> <p>CIRCUIT BOARD VOLTAGE CHART . . . . . 80</p> <p>IDENTIFICATION CHART . . . . . 81</p> <p>SCHEMATIC . . . . . (Fold-in)</p> <p>WARRANTY . . . . . Inside Front Cover</p> <p>CUSTOMER SERVICE . . . . . Inside Rear Cover</p>
-------------------------------------------------------------------------------------------------------------------------------------------------------------------------------------------------------------------------------------------------------------------------------------------------------------------------------------------------------------------------------------------------------------------------------------------------------------------------------------------------------------------------------------------------------------------------------------------------------------------------------------------------------------------------------------------------------------------------------------------------------------------------------------------------------------------------------------------------------------------------------------------------------------------------------------------------------------------------------------------------------------------------------------------------------------------------------------------------------------------------------------------------------------------------------------------------------------------------------------------------------	---------------------------------------------------------------------------------------------------------------------------------------------------------------------------------------------------------------------------------------------------------------------------------------------------------------------------------------------------------------------------------------------------------------------------------------------------------------------------------------------------------------------------------------------------------------------------------------------------------------------------------------------------------------------------------------------------------------------

# INTRODUCTION

The Heathkit Model HW-8 Transceiver is a solid-state, four-band QRP (low power) unit covering the CW portion of the eighty, forty, twenty, and fifteen meter amateur bands. The direct-conversion receiver features an RF stage, a balanced product detector, and an active audio filter with wide or narrow selectivity.

Other features include diode band switching which is controlled by pushbuttons and a method of premixing the variable and heterodyne oscillator signals to provide the same dial read-out on all bands. This also provides excellent stability and a fixed frequency offset on all bands while you are transmitting.

In addition to indicating Relative Power, the panel meter is used during alignment to assure proper adjustment of the transmitter tuned circuits.

The HW-8 Transceiver may be operated from the Heathkit Accessory Power Supply Model HWA-7-1, an equivalent low impedance power supply, or from batteries.

*Refer to the "Kit Builders Guide" for information on tools, wiring, soldering, resistors, and capacitors.*



# ASSEMBLY NOTES

A separate "Illustration Booklet" contains illustrations (Pictorials, Details, etc.) that are too large for the Assembly Manual. The illustrations are arranged in Pictorial number sequence. Place the Booklet in a convenient location and keep it with the Assembly Manual.

Each circuit part has its own component number (R2, C4, L3, etc.). Use these numbers when you want to identify the same part in the various sections of the Manual. These numbers, which are especially useful if a part has to be replaced, appear:

- In the parts list,
- At the beginning of each step where a component is installed,
- In some illustrations,

- In the Schematic,
- In the sections at the rear of the Manual.

Before you start to assemble this kit, read the wiring and soldering information in the "Kit Builders Guide."

Resistors are identified by their value in ohms ( $\Omega$ ), kilohms ( $k\Omega$ ) or megohms ( $M\Omega$ ) and by color code.

Capacitors are identified by their type (disc, Mylar\*, electrolytic, tuning, trimmer, or polystyrene), and capacitance value in  $\mu F$  or pF.

\*Registered DuPont Trademark.

## SOLDERING INSTRUCTIONS

Poor soldering accounts for about 90% of all kit building problems. The following photographs show examples of the types of bad solder connections that are the most common cause of trouble. If you locate any of these bad solder connections in your kit, correct them as instructed. Study this section carefully before you begin to assemble your kit.

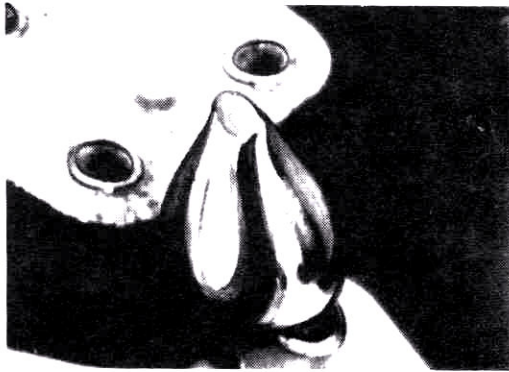

In this case, the solder was applied to the lead but did not flow onto the foil. To correct, reheat the connection.



Here, solder has flowed along a lead and bridged to another foil. To correct, hold the circuit board above the soldering iron and reheat the solder. As the solder melts, it will flow down the iron. Then cut off the excess lead length. PROTECT YOUR EYES.

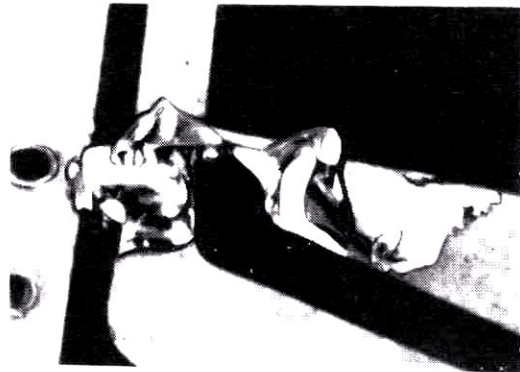

Here, hot solder has been dropped onto the foil and the solder connected or bridged (or crossed) three foils. To correct, hold the circuit board above the soldering iron and reheat the solder. As the solder melts, it will flow down the iron. PROTECT YOUR EYES.

NOTE: Solder that bridges two connections on the SAME FOIL is alright and should not be corrected.

Keep the soldering iron tip clean by wiping it from time to time with a damp sponge or cloth.



### A GOOD SOLDER CONNECTION

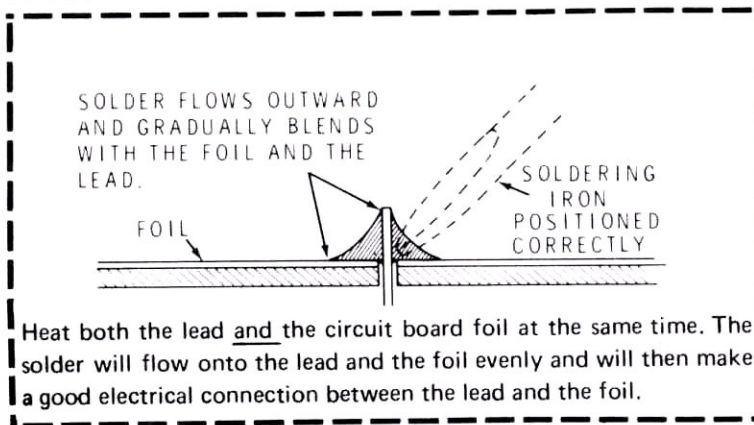

### BAD SOLDER CONNECTIONS

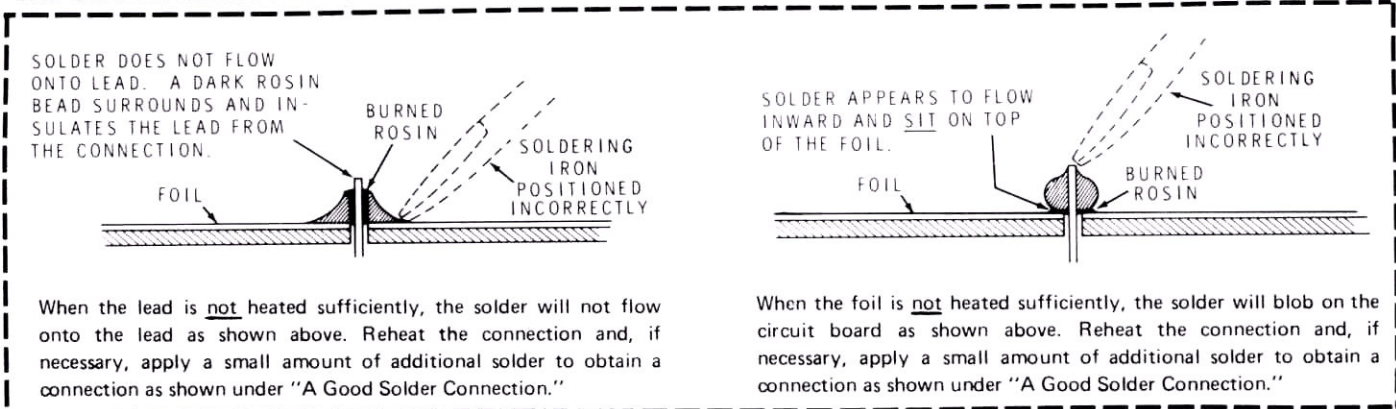



# CIRCUIT BOARD

## PARTS LIST

Open the container marked PTS #1 and check each part against the following list. You will also be instructed to remove some of the other parts that are left in the carton. These parts will be referred to as the "Parts From Final Pack." Make a check (✓) in the space provided as you identify each part. The illustrations show what the part looks like. Only the hardware is shown actual size.

Some parts are packaged in containers with the part number marked on the outside. Except for the initial parts check, keep these parts in their containers so they can be easily identified when they are called for in the assembly steps.

To order a replacement part, always include the PART NUMBER. Use the Parts Order Form furnished with the kit. If one is not available, see "Replacement Parts" inside the rear cover of this Manual. Your Warranty is located inside the front cover. For pricing information, refer to the separate "Heath Parts Price List."

<u>KEY</u>	<u>QTY.</u>	<u>DESCRIPTION</u>	<u>PART</u>	<u>CIRCUIT</u>
<u>No.</u>			<u>No.</u>	<u>Component No.</u>

### RESISTORS

NOTE: Resistors may be packed in more than one envelope. All resistors are 1/2-watt, 10% tolerance (silver fourth band) unless otherwise stated.

A1	( )	7	47 Ω (yellow-violet-black)	6-470	R13, R31, R54, R57, R59, R62, R201
A1	( )	10	100 Ω (brown-black-brown)	6-101	R14, R18, R28, R39, R41, R42, R46, R51, R55, R96
A1	( )	1	220 Ω (red-red-brown)	6-221	R206
A1	( )	2	270 Ω (red-violet-brown)	6-271	R6, R49
A1	( )	5	470 Ω (yellow-violet-brown)	6-471	R33, R34, R35, R56 R93
A1	( )	1	820 Ω (gray-red-brown)	6-821	R11

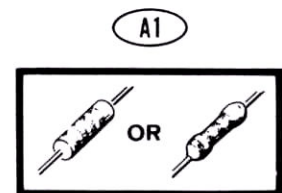

KEY No.	QTY.	DESCRIPTION	PART No.	CIRCUIT Component No.
<b>RESISTORS (cont'd.)</b>				
A1 ( )	19	1000 $\Omega$ (brown-black-red)	6-102	R1, R2, R3, R4, R7, R8, R12, R36, R58, R61, R63, R65, R69, R76, R78, R82, R85, R88, R205
A1 ( )	1	1200 $\Omega$ (brown-red-red)	6-122	R9
A1 ( )	2	2700 $\Omega$ (red-violet-red)	6-272	R16, R17
A1 ( )	1	3300 $\Omega$ (orange-orange-red)	6-332	R92
A1 ( )	5	4700 $\Omega$ (yellow-violet-red)	6-472	R53, R64, R66, R67, R202
A1 ( )	4	6800 $\Omega$ (blue-gray-red)	6-682	R79, R83, R86, R89
A1 ( )	4	10 k $\Omega$ (brown-black-orange)	6-103	R15, R50, R71, R204
A1 ( )	4	22 k $\Omega$ (red-red-orange)	6-223	R29, R37, R52, R95
A1 ( )	6	47 k $\Omega$ (yellow-violet-orange)	6-473	R19, R44, R47, R48, R75, R203
A1 ( )	2	68 k $\Omega$ (blue-gray-orange)	6-683	R38, R94
A1 ( )	2	82 k $\Omega$ (gray-red-orange)	6-823	R21, R24
A1 ( )	7	100 k $\Omega$ (brown-black-yellow)	6-104	R5, R43, R45, R81, R84, R87, R91
A1 ( )	2	470 k $\Omega$ (yellow-violet-yellow)	6-474	R22, R23
A1 ( )	3	1 M $\Omega$ (brown-black-green)	6-105	R25, R27, R32
A1 ( )	1	2.2 M $\Omega$ (red-red-green)	6-225	R26
A1 ( )	1	3.3 M $\Omega$ (orange-orange-green)	6-335	R72
A1 ( )	2	10 M $\Omega$ (brown-black-blue)	1-40	R73, R74

A1

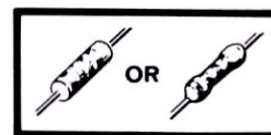

KEY No.	QTY.	DESCRIPTION	PART No.	CIRCUIT Component No.
---------	------	-------------	----------	-----------------------

**CAPACITORS**
**Mica**

B1 ( )	1	24 pF	20-77	C123
B1 ( )	5	47 pF	20-101	C71, C87, C88, C15, C121
B1 ( )	2	68 pF	20-76	C1, C4
B1 ( )	2	75 pF	20-110	C18, C104
B1 ( )	6	100 pF	20-102	C61, C68, C98, C101, C107, C116
B1 ( )	3	130 pF	20-104	C84, C85, C118
B1 ( )	3	150 pF	20-103	C66, C96, C108
B1 ( )	1	200 pF	20-108	C105
B1 ( )	2	230 pF	20-111	C64, C82
B1 ( )	2	270 pF	20-114	C94, C114
B1 ( )	1	330 pF	20-139	C78
B1 ( )	1	400 pF	20-116	C102
B1 ( )	1	470 pF	20-128	C81
B1 ( )	2	680 pF	20-107	C77, C97



**Disc**

C1 ( )	4	3.3 pF	21-33	C12, C54, C73, C127
C1 ( )	1	5 pF	21-157	C125
C1 ( )	1	6 pF	21-169	C55
C1 ( )	1	6.8 pF	21-703	C47
C1 ( )	2	10 pF	21-3	C25, C126
C1 ( )	1	27 pF	21-716	C48
C1 ( )	2	56 pF	21-160	C49, C51
C1 ( )	3	510 pF	21-191	C44, C45, C46
C1 ( )	34	.05 $\mu$ F	21-143	C2, C5, C8, C11, C13, C14, C17, C21, C23, C28, C29, C43, C52, C56, C57, C58, C59, C62, C63, C65, C67, C69, C72, C75, C76, C79, C83, C86, C89, C115, C117, C119, C122, C128

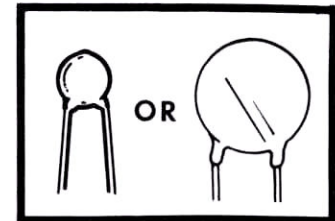
C1

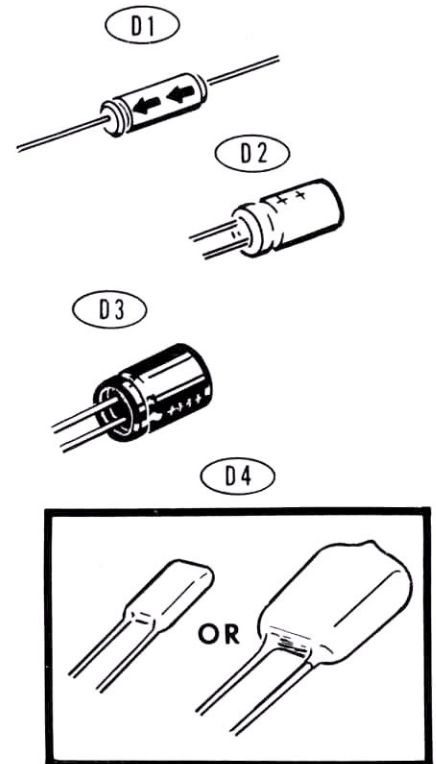

KEY No.	QTY.	DESCRIPTION	PART No.	CIRCUIT Component No.
<b>Other Capacitors</b>				
D1 ( )	5	2 $\mu$ F electrolytic	25-123	C38, C42, C91, C201, C204
D1 ( )	1	25 $\mu$ F electrolytic	25-96	C205
D2 ( )	2	10 $\mu$ F electrolytic	25-115	C33, C92
D3 ( )	3	100 $\mu$ F electrolytic	25-117	C32, C41, C202
D4 ( )	1	.022 $\mu$ F Mylar	27-63	C109
D4 ( )	9	.1 $\mu$ F Mylar	27-47	C26, C27, C31, C39, C74, C111, C112, C113, C203
D4 ( )	1	.47 $\mu$ F Mylar	27-86	C93
D5 ( )	2	1000 pF polystyrene	29-5	C36, C37
D5 ( )	2	1800 pF, (1.8n) polystyrene	29-4	C34, C35
D6 ( )	1	4.7 pF ceramic	21-29	C53
D7 ( )	3	4 to 40 pF trimmer	31-54	C6, C16, C19
D7 ( )	9	8 to 60 pF trimmer	31-52	C3, C7, C9, C22, C24, C95, C99, C103, C106



**TRANSISTORS – INTEGRATED CIRCUITS (IC's)**

NOTE: Transistors and IC's are marked for identification in one of the following ways:

1. Part number.
2. Type number. (On integrated circuits this refers only to the numbers; the letters may be different or missing.)
3. Part number and type number.
4. Part number and a type number other than the one listed.

D8 ( )	2	MPF105 transistor (JFET)	417-169	Q1, Q2
D8 ( )	6	MPS-A20 transistor	417-801	Q3, Q5, Q7, Q12, Q14, Q201
D8 ( )	1	S2091 transistor	417-116	Q11
D9 ( )	1	40673 transistor (MFET)	417-240	Q4

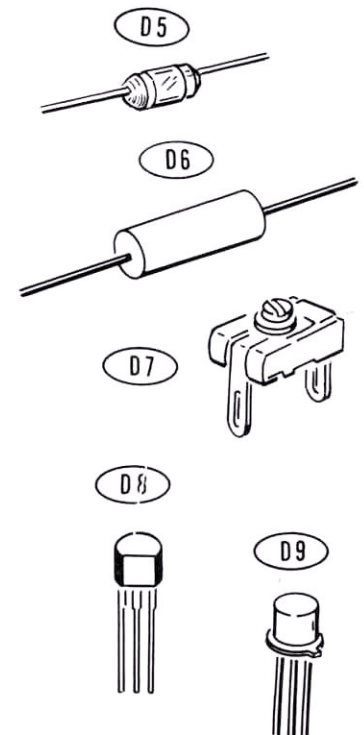

KEY No.	QTY.	DESCRIPTION	PART No.	CIRCUIT Component No.
---------	------	-------------	----------	-----------------------

**Transistors-Integrated Circuits (IC's)**

D10 ( )	2	MPS6521 transistor	417-172	Q6, Q8
D11 ( )	1	2N4427 transistor	417-880	Q9
D12 ( )	1	X29A829 transistor	417-201	Q13
D13 ( )	1	MC1496G IC (integrated circuit)	442-96	IC1
D14 ( )	1	LM3900	442-71	IC2

D10

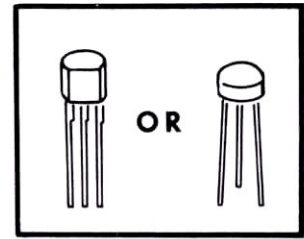
**CRYSTALS**

D15 ( )	1	12.395 MHz	404-207	Y1
D15 ( )	1	15.895 MHz	404-208	Y2
D15 ( )	1	22.895 MHz	404-209	Y3
D15 ( )	1	29.895 MHz	404-210	Y4

D11

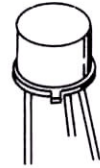

D12



D13



D14

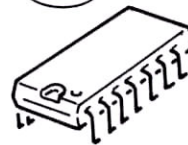

D15



KEY No.	QTY.	DESCRIPTION	PART No.	CIRCUIT Component No.
---------	------	-------------	----------	-----------------------

D16 ( )	1	1000 $\Omega$ control	10-936	R77
D16 ( )	1	50 k $\Omega$ control	10-222	R68



CAUTION: Do not remove the coils or chokes from their envelopes until they are called for in a step.

E1 ( )	4	1.3 $\mu$ H toroid coil	40-1800	L8, L25, L33, L34
E1 ( )	2	1.8 $\mu$ H toroid coil	40-1792	L7, L24
E1 ( )	2	2.5 $\mu$ H toroid coil	40-1609	L31, L32
E1 ( )	2	4.2 $\mu$ H toroid coil	40-1798	L6, L23
E1 ( )	2	7.0 $\mu$ H toroid coil	40-1726	L28, L29
E1 ( )	1	9.0 $\mu$ H toroid coil	40-1797	L22
E1 ( )	2	15.5 $\mu$ H toroid coil	40-1882	L5, L26
E1 ( )	1	27.5 $\mu$ H toroid coil	40-1791	L27
E2 ( )	2	15.0 $\mu$ H toroid coil	40-1050	L11, L12
E3 ( )	2	1.8 $\mu$ H toroid coil	40-1788	L3, L4
E3 ( )	1	4.7 $\mu$ H toroid coil	40-1787	L2
E3 ( )	1	13.0 $\mu$ H toroid coil	40-1786	L1
E4 ( )	1	.83 $\mu$ H coil	40-1804	L19/L21
E4 ( )	1	1.47 $\mu$ H coil	40-1803	L17/L18
E5 ( )	1	4.0 $\mu$ H coil	40-1795	L14
E5 ( )	2	1.3 $\mu$ H coil	40-1796	L15, L16
E5 ( )	1	8.0 $\mu$ H coil	40-1794	L13
E6 ( )	1	5.0 $\mu$ H coil	40-1802	L9
E7 ( )	1	26.0 $\mu$ H choke	45-62	RFC3
E8 ( )	2	350 $\mu$ H choke	45-82	RFC1, RFC2

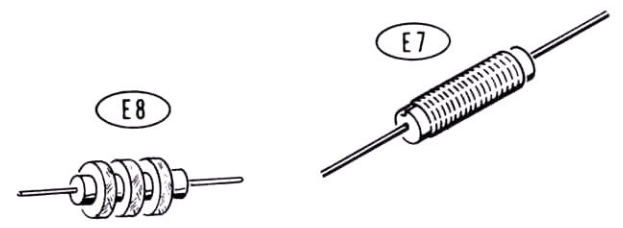
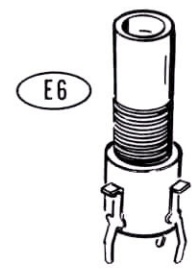
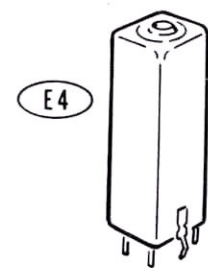
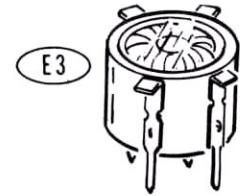
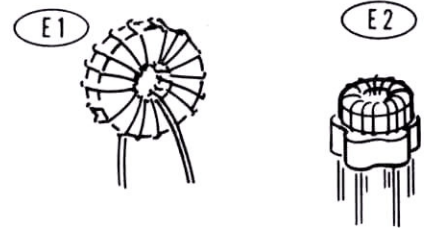



KEY No.	QTY.	DESCRIPTION	PART No.	CIRCUIT Component No.
---------	------	-------------	----------	-----------------------

**DIODES**

E9 ( )	1	VR-9.1 zener	56-19	ZD1
E9 ( )	1	VR-36 zener	56-55	ZD2
E9 ( )	4	FH1100	56-87	D12, D13, D14, D15
E9 ( )	23	1N458	56-24	D1, D2, D3, D4, D5, D6, D7, D8, D9, D11, D16, D17, D18, D19, D21, D31, D32, D33, D34, D35, D36, D37, D38
E9 ( )	8	1N4149	56-56	D22, D23, D24, D25, D26, D27, D28, D29

E9

NOTE: HEATH PART NUMBERS ARE STAMPED ON MOST DIODES.

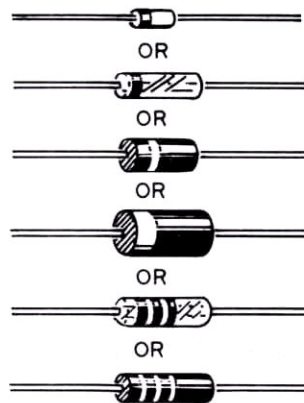

**MISCELLANEOUS**

E10 ( )	1	Pushbutton switch assembly	64-775	SW1, SW2, SW3, SW4
E11 ( )	1	Relay	69-47	RY1
E12 ( )	1	Heat sink	215-45	
E13 ( )	1	IC socket	434-298	
E14 ( )	1	Ferrite bead	475-10	

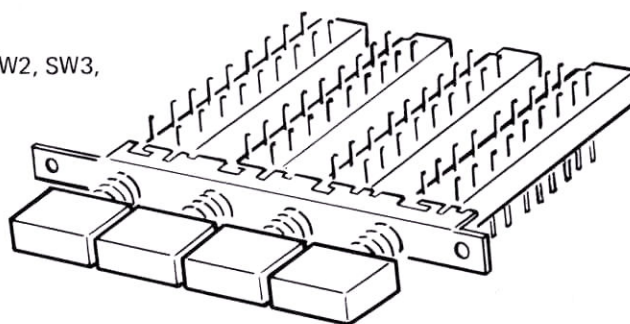
E10

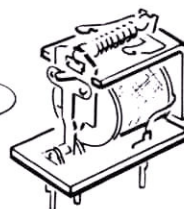

E11



E12



E13

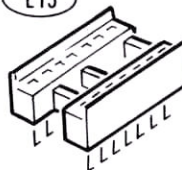

E14



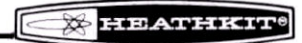

KEY No.	QTY.	DESCRIPTION	PART No.	CIRCUIT Component No.
---------	------	-------------	----------	-----------------------

**Miscellaneous (cont'd.)**

E15 ( )	3	Cable tie	354-5	
E16 ( )	4	6-32 x 1/4" screw	250-56	
E17 ( )	3	6-32 nut	252-3	
E18 ( )	4	#6 lockwasher	254-1	
E19 ( )	1	6-32 x 1/2" spacer	255-23	

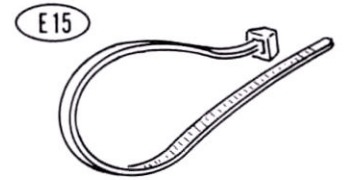

E16



E17



E18



E19



**PARTS FROM FINAL PACK**

E20 ( )	1	Nut starter	490-5	
E21 ( )	1	Angle bracket	204-1844	
( )	11'	Yellow wire	344-54	
( )	5'	5-wire cable	347-39	
( )	6'	Shielded cable	343-15	
( )	1	Main circuit board	85-1748-5	
( )	1	AF Amplifier circuit board	85-1677-1	
( )		Solder		

E20

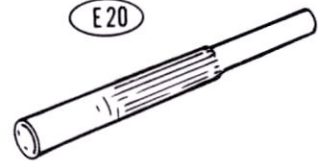

E21

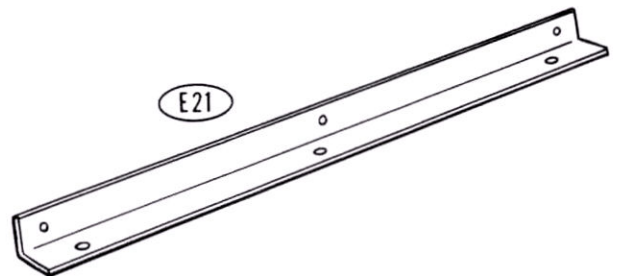

**PRINTED MATERIAL**

NOTE: Be sure you refer to the numbers on the blue and white label in any communications you may have about this kit with Heath Company. You may want to write the model and series numbers in the sample label for future convenience.

( )	1	Blue and white label	391-34
( )	1	Parts Order Form	597-260
( )	1	Kit Builders Guide	597-308
( )	1	Manual (See front cover for part number.)	

391-34

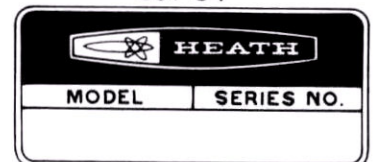

# STEP-BY-STEP ASSEMBLY

## START

Position the AF Amplifier circuit board as shown. Then perform the steps in the order listed.

NOTE: When you install an electrolytic capacitor, always connect the lead at the positive (+) end of the capacitor to the positive (+) marked point on the circuit board. Be careful, only the negative end of the capacitor may be marked.

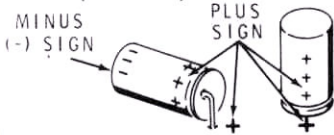

- ( ) C205: 25  $\mu$ F electrolytic.

NOTE: When you install the following transistor, line up the flat on the transistor with the outline of the flat on the circuit board. Then insert the E, B, and C leads of the transistor into the corresponding E, B, and C holes in the circuit board. Position the transistor 1/4" above the circuit board, solder the leads to the foil, and cut off the excess lead lengths.

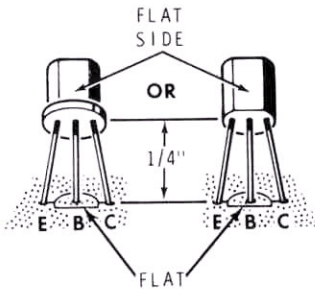

- ( ) Q201: MPS-A20 transistor (#417-801).

- ( ) C204: 2  $\mu$ F electrolytic.

- ( ) R201: 47  $\Omega$  (yellow-violet-black).

- ( ) R202: 4700  $\Omega$  (yellow-violet-red).

- ( ) C201: 2  $\mu$ F electrolytic.

- ( ) Solder the leads to the foil and cut off the excess lead lengths.

FOR GOOD SOLDER CONNECTIONS, YOU MUST KEEP THE SOLDERING IRON TIP CLEAN. WIPE IT OFTEN WITH A DAMP SPONGE OR CLOTH.



## CONTINUE

- ( ) R206: 220  $\Omega$  (red-red-brown).
- ( ) C203: .1  $\mu$ F Mylar.
- ( ) R204: 10 k $\Omega$  (brown-black-orange).
- ( ) R205: 1000  $\Omega$  (brown-black-red).
- ( ) R203: 47 k $\Omega$  (yellow-violet-orange).
- ( ) C202: 100  $\mu$ F electrolytic.
- ( ) Solder the leads to the foil and cut off the excess lead lengths.

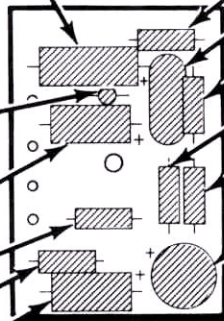

PICTORIAL 1-1

**START**

FOR GOOD SOLDER CONNECTIONS, YOU MUST KEEP THE SOLDERING IRON TIP CLEAN. WIPE IT OFTEN WITH A DAMP SPONGE OR CLOTH.



NOTE: When you prepare the wires in the following steps, cut the wire to the length specified in the step and remove 1/4" of insulation from each end. Solder one end of each wire to the foil and cut off the excess wire lengths.

- ( ) 2" yellow wire.
- ( ) 2-3/4" yellow wire.
- ( ) 3" yellow wire.

NOTE: The hole marked "IN" on the circuit board will be used later.

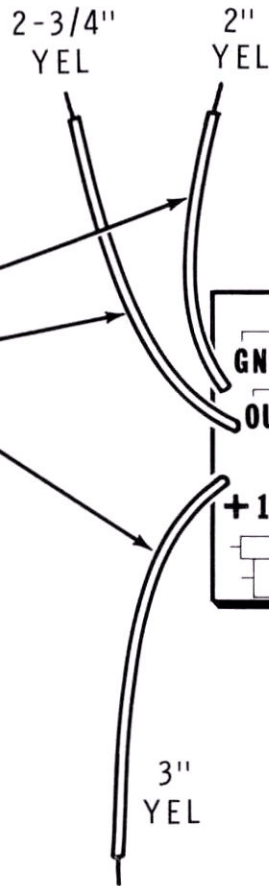

PICTORIAL 1-2

**CONTINUE**

CAUTION: When you perform the next step, be sure the lockwasher does not touch the adjacent foil.

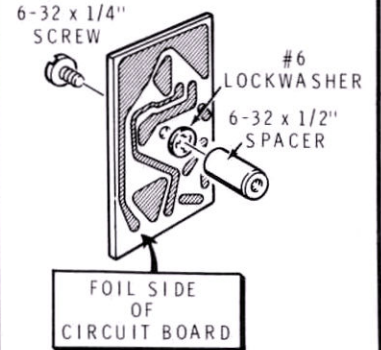

- ( ) Mount a 6-32 x 1/2" spacer on the foil side of the circuit board as shown above.

**CIRCUIT BOARD CHECKOUT**

Carefully inspect the circuit board for the following conditions.

- ( ) Unsoldered connections.
- ( ) "Cold" solder connections.
- ( ) Solder bridges between foil patterns.
- ( ) Protruding leads which could touch together.
- ( ) Transistors for the proper type and installation.
- ( ) Electrolytic capacitors for the correct position of the positive (+) lead.

Set the circuit board aside until it is called for later.

**FINISH**



The steps performed in this Pictorial are in this area of the circuit board.

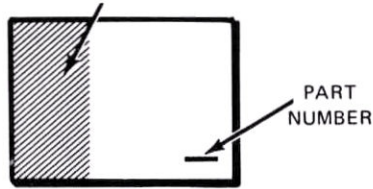

IDENTIFICATION DRAWING

**START** →

Position the main circuit board foil-side-up as shown below. Then clean the indicated circuit board edges with an eraser to remove any lacquer which may cover the foil. This will assure a good ground connection when the circuit board is mounted later.

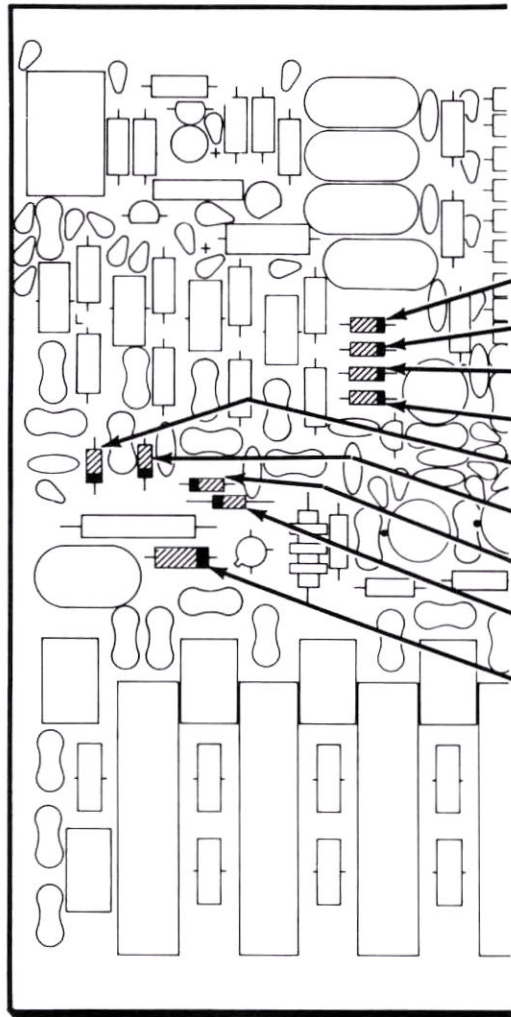
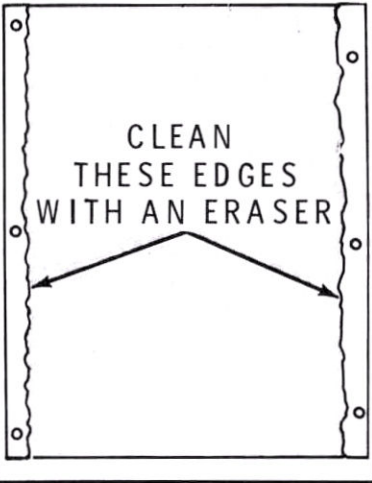

**CONTINUE** ↘

Position the main circuit board component side up as shown. Then perform the steps in the order listed.

**IMPORTANT: THE BANDED END OF DIODES CAN BE MARKED IN A NUMBER OF WAYS.**

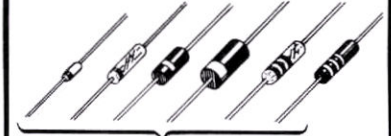

**BANDED END**

BE SURE YOU INSTALL EACH DIODE SO ITS BANDED END IS POSITIONED AS SHOWN IN THE PICTORIAL.

Install eight 1N458 diodes (#56-24).

- ( ) D34.
- ( ) D33.
- ( ) D32.
- ( ) D31.
- ( ) D35.
- ( ) D36.
- ( ) D37.
- ( ) D38.
- ( ) ZD2: VR-36A zener diode (#56-55).
- ( ) Solder the leads to the foil and cut off the excess lead lengths.

PICTORIAL 2-1

The steps performed in this Pictorial are in this area of the circuit board.

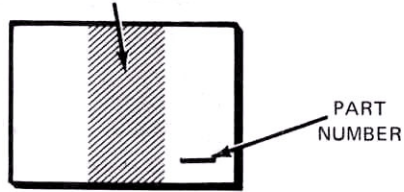

IDENTIFICATION DRAWING

**START** ▼

**FOR GOOD SOLDER CONNECTIONS, YOU MUST KEEP THE SOLDERING IRON TIP CLEAN. WIPE IT OFTEN WITH A DAMP SPONGE OR CLOTH.**

Install eight 1N4149 diodes (#56-56).

- ( ) D23. ....
- ( ) D22. ....
- ( ) D24. ....
- ( ) D25. ....
- ( ) D26. ....
- ( ) D29. ....
- ( ) D27. ....
- ( ) D28. ....

( ) Solder the leads to the foil and cut off the excess lead lengths.

Install six 1N458 diodes (#56-24).

- ( ) D16. ....
- ( ) D17. ....
- ( ) D18. ....
- ( ) D19. ....
- ( ) D9. ....
- ( ) D11. ....

( ) Solder the leads to the foil and cut off the excess lead lengths.

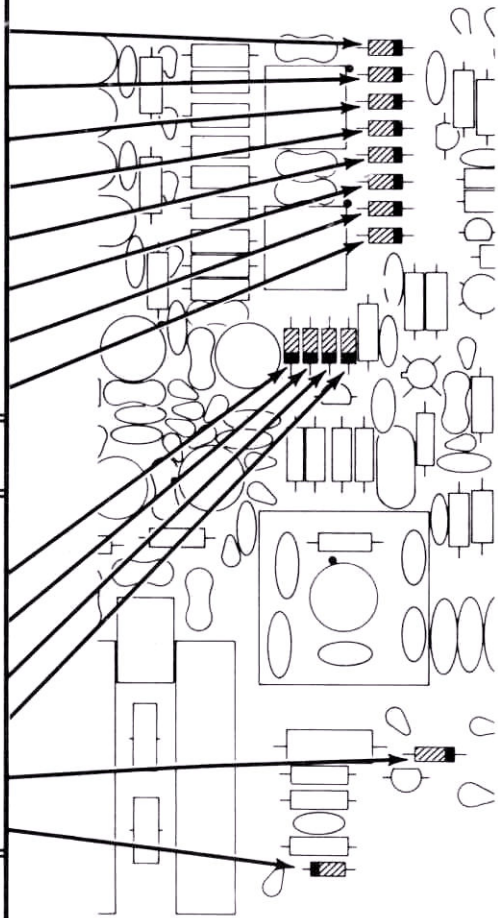

PICTORIAL 2-2

The steps performed in this Pictorial are in this area of the circuit board.

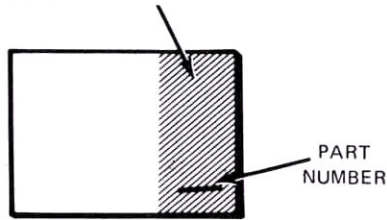

IDENTIFICATION DRAWING

**START** ▾

- ( ) D21: 1N458 diode (#56-24).
- Install four FH1100 diodes (#56-87).
- ( ) D12. ....
- ( ) D13. ....
- ( ) D15. ....
- ( ) D14. ....
- Install two 1N458 diodes (#56-24).
- ( ) D8. ....
- ( ) D7. ....
- ( ) ZD1: VR-9.1 zener diode (#56-19).
- ( ) 1-1/2" yellow wire at J.
- ( ) Solder the leads to the foil and cut off the excess lead lengths.

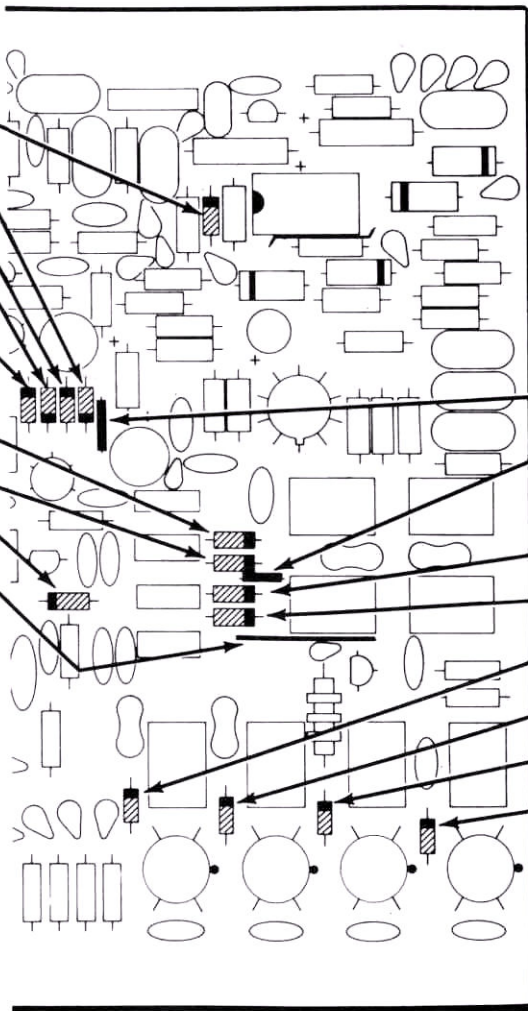

**CONTINUE** ▾

- ( ) 1" yellow wire at J.
- ( ) 1" yellow wire at J.
- Install six 1N458 diodes (#56-24).
- ( ) D6.
- ( ) D5.
- ( ) D1.
- ( ) D2.
- ( ) D3.
- ( ) D4.
- ( ) Solder the leads to the foil and cut off the excess lead lengths.

PICTORIAL 2-3

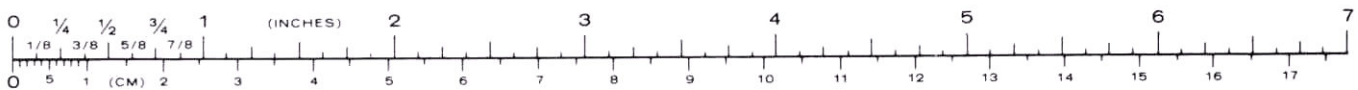

The steps performed in this Pictorial are in this area of the circuit board.

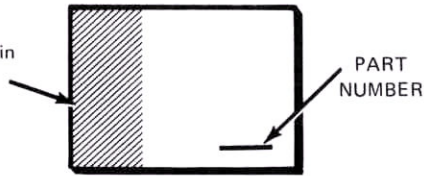

IDENTIFICATION DRAWING

**START** ▾

FOR GOOD SOLDER CONNECTIONS, YOU MUST KEEP THE SOLDERING IRON TIP CLEAN. WIPE IT OFTEN WITH A DAMP SPONGE OR CLOTH.

- ( ) R67: 4700 Ω (yellow-violet-red).
- ( ) R69: 1000 Ω (brown-black-red).
- ( ) R71: 10 kΩ (brown-black-orange).
- ( ) R57: 47 Ω (yellow-violet-black).
- ( ) R54: 47 Ω (yellow-violet-black).
- ( ) R58: 1000 Ω (brown-black-red).
- ( ) R56: 470 Ω (yellow-violet-brown).
- ( ) R61: 1000 Ω (brown-black-red).
- ( ) Solder the leads to the foil and cut off the excess lead lengths.

**CONTINUE** ▾

- ( ) R66: 4700 Ω (yellow-violet-red).
- ( ) R64: 4700 Ω (yellow-violet-red).
- ( ) R65: 1000 Ω (brown-black-red).
- ( ) R59: 47 Ω (yellow-violet-black).
- ( ) R62: 47 Ω (yellow-violet-black).
- ( ) R63: 1000 Ω (brown-black-red).



- ( ) R55: 100 Ω (brown-black-brown).
- ( ) R53: 4700 Ω (yellow-violet-red).
- ( ) Solder the leads to the foil and cut off the excess lead lengths.

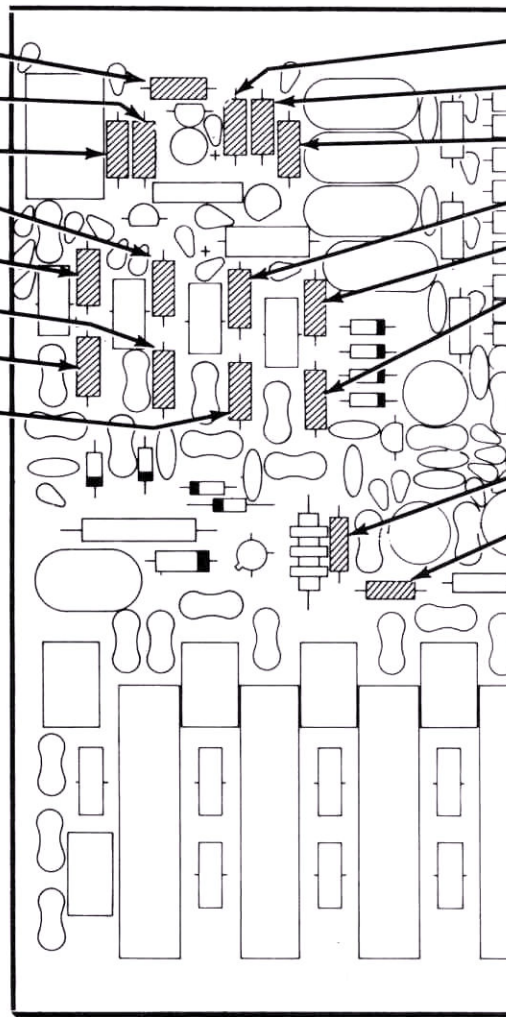

PICTORIAL 2-4



The steps performed in this Pictorial are in this area of the circuit board.

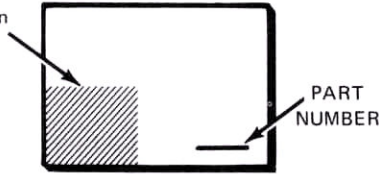

IDENTIFICATION DRAWING

**START** →

NOTES:

1. You will install four trimmer capacitors on the circuit board in the following steps. Note that there are two different values of trimmers.
2. Some of the trimmer lugs have two or more leaves. When you install the trimmer, make sure all of the lug leaves go through the circuit board.
3. IT IS VERY IMPORTANT to solder the correct trimmer lug to the correct foil. One lug on each trimmer will be called the ground lug. This is the lug that is connected to the metal plate directly under the screw on the trimmer.

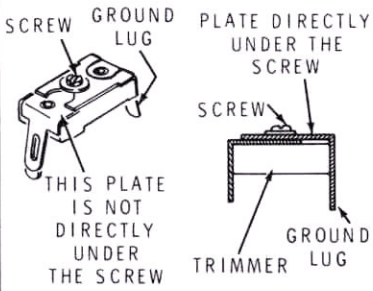

4. Make sure that each trimmer capacitor is properly positioned and soldered to the foil. If a trimmer lug has more than one leaf, make sure all leaves are soldered.

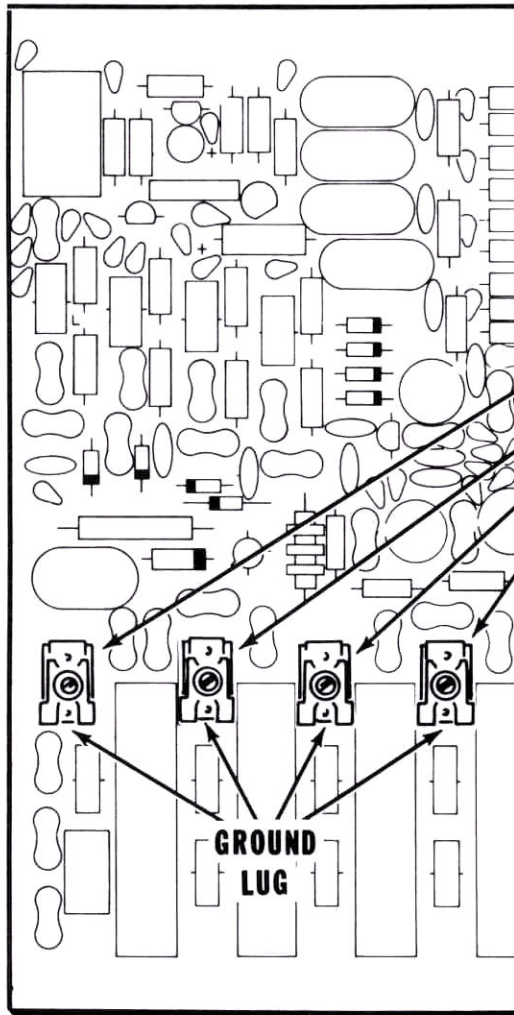
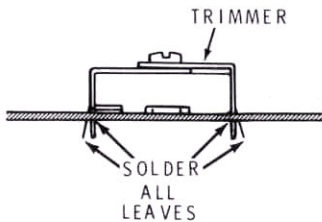

**CONTINUE** →

NOTE: In the following steps, solder the lugs to the foil as you install each trimmer.

- ( ) C95: 8-60 pF trimmer (#31-52).
- ( ) C99: 8-60 pF trimmer (#31-52).
- ( ) C103: 8-60 pF trimmer (#31-52).
- ( ) C106: 8-60 pF trimmer (#31-52).

PICTORIAL 2-5

The steps performed in this Pictorial are in this area of the circuit board.

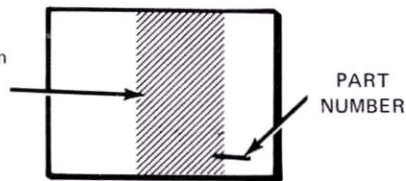

**START** →

**FOR GOOD SOLDER CONNECTIONS, YOU MUST KEEP THE SOLDERING IRON TIP CLEAN. WIPE IT OFTEN WITH A DAMP SPONGE OR CLOTH.**

- ( ) R79: 6800 Ω (blue-gray-red).
- ( ) R81: 100 kΩ (brown-black-yellow).
- ( ) R83: 6800 Ω (blue-gray-red).
- ( ) R82: 1000 Ω (brown-black-red).
- ( ) R84: 100 kΩ (brown-black-yellow).
- ( ) R85: 1000 Ω (brown-black-red).
- ( ) R87: 100 kΩ (brown-black-yellow).
- ( ) R91: 100 kΩ (brown-black-yellow).
- ( ) Solder the leads to the foil and cut off the excess lead lengths.
- ( ) R51: 100 Ω (brown-black-brown).
- ( ) R52: 22 kΩ (red-red-orange).
- ( ) R49: 270 Ω (red-violet-brown).
- ( ) R34: 470 Ω (yellow-violet-brown).
- ( ) R36: 1000 Ω (brown-black-red).
- ( ) Solder the leads to the foil and cut off the excess lead lengths.

IDENTIFICATION DRAWING

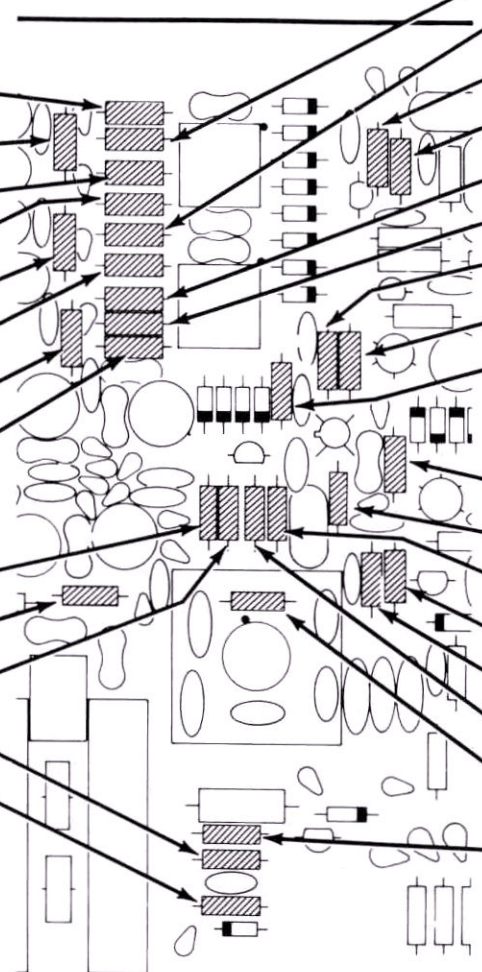

**CONTINUE** ↘

- ( ) R78: 1000 Ω (brown-black-red).
- ( ) R86: 6800 Ω (blue-gray-red).
- ( ) R92: 3300 Ω (orange-orange-red).
- ( ) R93: 470 Ω (yellow-violet-brown).
- ( ) R89: 6800 Ω (blue-gray-red).
- ( ) R88: 1000 Ω (brown-black-red).
- ( ) R44: 47 kΩ (yellow-violet-orange).
- ( ) R45: 100 kΩ (brown-black-yellow).
- ( ) R46: 100 Ω (brown-black-brown).
- ( ) Solder the leads to the foil and cut off the excess lead lengths.
- ( ) R39: 100 Ω (brown-black-brown).
- ( ) R43: 100 kΩ (brown-black-yellow).
- ( ) R47: 47 kΩ (yellow-violet-orange).
- ( ) R38: 68 kΩ (blue-gray-orange).
- ( ) R33: 470 Ω (yellow-violet-brown).
- ( ) R48: 47 kΩ (yellow-violet-orange).
- ( ) R31: 47 Ω (yellow-violet-black).
- ( ) R32: 1 MΩ (brown-black-green).
- ( ) Solder the leads to the foil and cut off the excess lead lengths.

**PICTORIAL 2-6**

The steps performed in this Pictorial are in this area of the circuit board.

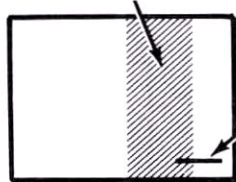

IDENTIFICATION DRAWING

**CONTINUE** ↘

- ( ) R77: 1000 Ω control (#10-936).  
Solder the lugs to the foil.



**START** ↙

- ( ) R76: 1000 Ω (brown-black-red).
- ( ) R95: 22 kΩ (red-red-orange).
- ( ) R94: 68 kΩ (blue-gray-orange).
- ( ) R26: 2.2 MΩ (red-red-green).
- ( ) R42: 100 Ω (brown-black-brown).
- ( ) R18: 100 Ω (brown-black-brown).
- ( ) Solder the leads to the foil and cut off the excess lead lengths.
- ( ) R41: 100 Ω (brown-black-brown).
- ( ) R37: 22 kΩ (red-red-orange).
- ( ) R35: 470 Ω (yellow-violet-brown).
- Install four 1000 Ω (brown-black-red) resistors.
- ( ) R1. ....
- ( ) R2. ....
- ( ) R3. ....
- ( ) R4. ....
- ( ) Solder the leads to the foil and cut off the excess lead lengths.

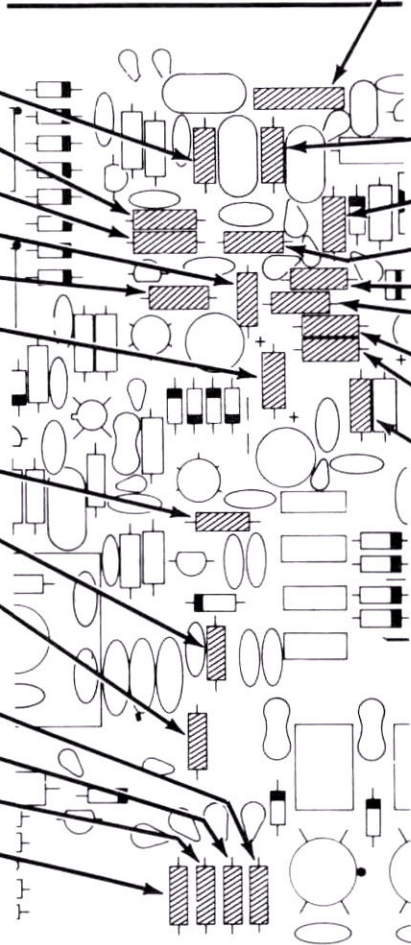

- ( ) R75: 47 kΩ (yellow-violet-orange).
- ( ) R74: 10 MΩ (brown-black-blue).
- ( ) R96: 100 Ω (brown-black-brown).
- ( ) R73: 10 MΩ (brown-black-blue).
- ( ) R28: 100 Ω (brown-black-brown).
- ( ) R17: 2700 Ω (red-violet-red).
- ( ) R16: 2700 Ω (red-violet-red).
- ( ) R11: 820 Ω (gray-red-brown).
- ( ) Solder the leads to the foil and cut off the excess lead lengths.

PICTORIAL 2-7

The steps performed in this Pictorial are in this area of the circuit board.

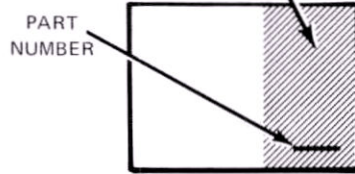

IDENTIFICATION DRAWING

**START** ↘

FOR GOOD SOLDER CONNECTIONS, YOU MUST KEEP THE SOLDERING IRON TIP CLEAN. WIPE IT OFTEN WITH A DAMP SPONGE OR CLOTH.



- ( ) R29: 22 kΩ (red-red-orange).
- ( ) R27: 1 MΩ (brown-black-green).
- ( ) R72: 3.3 MΩ (orange-orange-green).
- ( ) R22: 470 kΩ (yellow-violet-yellow).
- ( ) R19: 47 kΩ (yellow-violet-orange).
- ( ) R15: 10 kΩ (brown-black-orange).
- ( ) R8: 1000 Ω (brown-black-red).
- ( ) R13: 47 Ω (yellow-violet-black).
- ( ) R14: 100 Ω (brown-black-brown).
- ( ) R12: 1000 Ω (brown-black-red).
- ( ) Solder the leads to the foil and cut off the excess lead lengths.

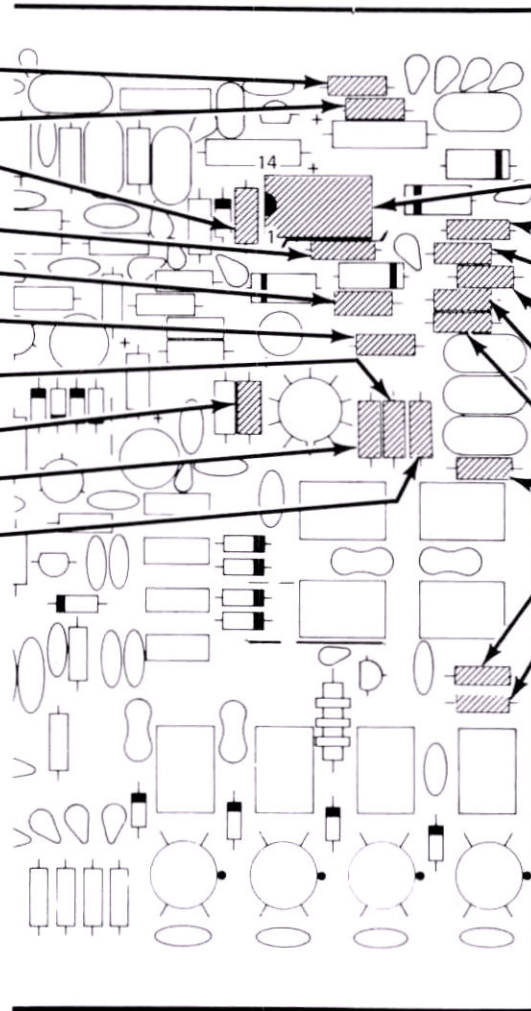

**CONTINUE** ↙

NOTE: To install an IC socket be sure the socket pins are straight. Then insert the socket pins and solder them to the foil.

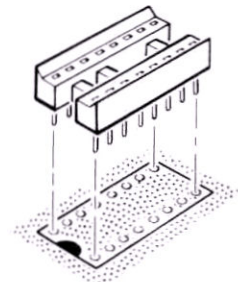

- ( ) 14-pin IC socket at IC2.
- ( ) R25: 1 MΩ (brown-black-green).
- ( ) R23: 470 kΩ (yellow-violet-yellow).
- ( ) R24: 82 kΩ (gray-red-orange).
- ( ) R21: 82 kΩ (gray-red-orange).
- ( ) R9: 1200 Ω (brown-red-red).
- ( ) R7: 1000 Ω (brown-black-red).
- ( ) R6: 270 Ω (red-violet-brown).
- ( ) R5: 100 kΩ (brown-black-yellow).
- ( ) Solder the leads to the foil and cut off the excess lead lengths.

PICTORIAL 2-8

The steps performed in this Pictorial are in this area of the circuit board.

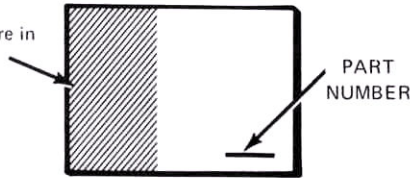

IDENTIFICATION DRAWING

**START**

FOR GOOD SOLDER CONNECTIONS, YOU MUST KEEP THE SOLDERING IRON TIP CLEAN.

WIPE IT OFTEN WITH A DAMP SPONGE OR CLOTH.



- ( ) C87: 47 pF mica.
- ( ) C84: 130 pF mica.
- ( ) C81: 470 pF mica.
- ( ) C114: 270 pF mica.
- ( ) C82: 230 pF mica.
- ( ) C77: 680 pF mica.
- ( ) C78: 330 pF mica.
- ( ) Solder the leads to the foil and cut off the excess lead lengths.

NOTE: When you install disc capacitors, do not push the insulated portions of the leads into the circuit board holes. This could make it difficult to solder the leads to the foil.

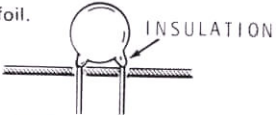

- ( ) C79: .05  $\mu$ F disc.
- ( ) C83: .05  $\mu$ F disc.
- ( ) C85: 130 pF mica.
- ( ) C86: .05  $\mu$ F disc.
- ( ) C96: 150 pF mica.
- ( ) C94: 270 pF mica.
- ( ) C97: 680 pF mica.
- ( ) Solder the leads to the foil and cut off the excess lead lengths.

**CONTINUE**

- ( ) C115: .05  $\mu$ F disc.
- ( ) C117: .05  $\mu$ F disc.
- ( ) C89: .05  $\mu$ F disc.
- ( ) C119: .05  $\mu$ F disc.
- ( ) C76: .05  $\mu$ F disc.
- ( ) C66: 150 pF mica.
- ( ) C122: .05  $\mu$ F disc.
- ( ) C64: 230 pF mica.
- ( ) Solder the leads to the foil and cut off the excess lead lengths.
- ( ) C67: .05  $\mu$ F disc.
- ( ) C69: .05  $\mu$ F disc.
- ( ) C71: 47 pF mica.
- ( ) C68: 100 pF mica
- ( ) C107: 100 pF mica.
- ( ) C108: 150 pF mica.
- ( ) C104: 75 pF mica.
- ( ) C88: 47 pF mica.
- ( ) C105: 200 pF mica.
- ( ) C98: 100 pF mica.
- ( ) C101: 100 pF mica.
- ( ) C102: 400 pF mica.
- ( ) Solder the leads to the foil and cut off the excess lead lengths.

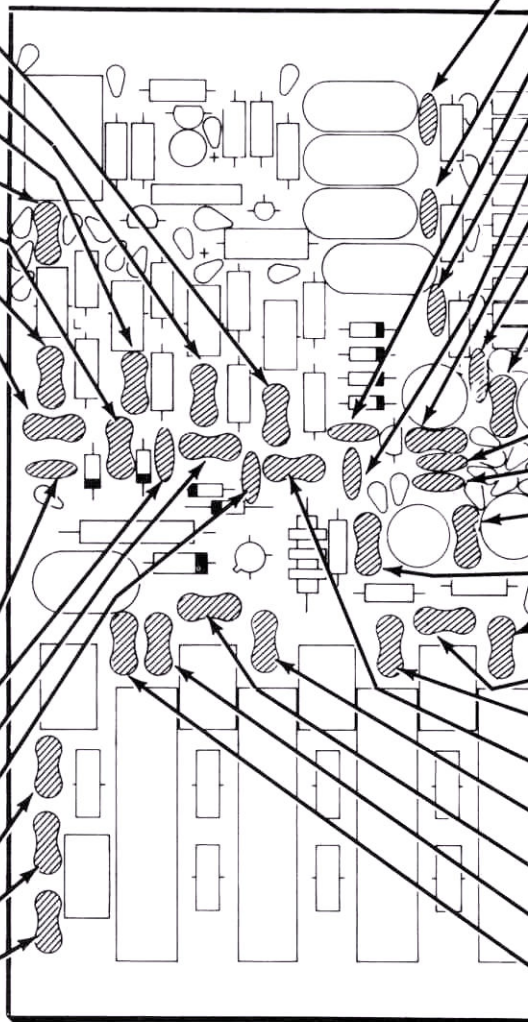

PICTORIAL 2-9

The steps performed in this Pictorial are in this area of the circuit board.

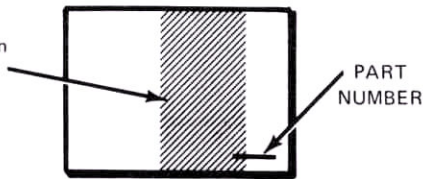

IDENTIFICATION DRAWING

**START**

**FOR GOOD SOLDER CONNECTIONS, YOU MUST KEEP THE SOLDERING IRON TIP CLEAN.**

WIPE IT OFTEN WITH A DAMP SPONGE OR CLOTH.



- C116: 100 pF mica.
- C118: 130 pF mica.
- C121: 47 pF mica.
- C58: .05  $\mu$ F disc.
- C73: 3.3 pF disc.
- C123: 24 pF mica.
- C65: .05  $\mu$ F disc.
- C72: .05  $\mu$ F disc.
- Solder the leads to the foil and cut off the excess lead lengths.
- C47: 6.8 pF disc.
- C75: .05  $\mu$ F disc.
- C51: 56 pF disc.
- C54: 3.3 pF disc.
- C49: 56 pF disc.
- C48: 27 pF disc.
- C53: 4.7 pF ceramic.
- C55: 6 pF disc.
- Solder the leads to the foil and cut off the excess lead lengths.

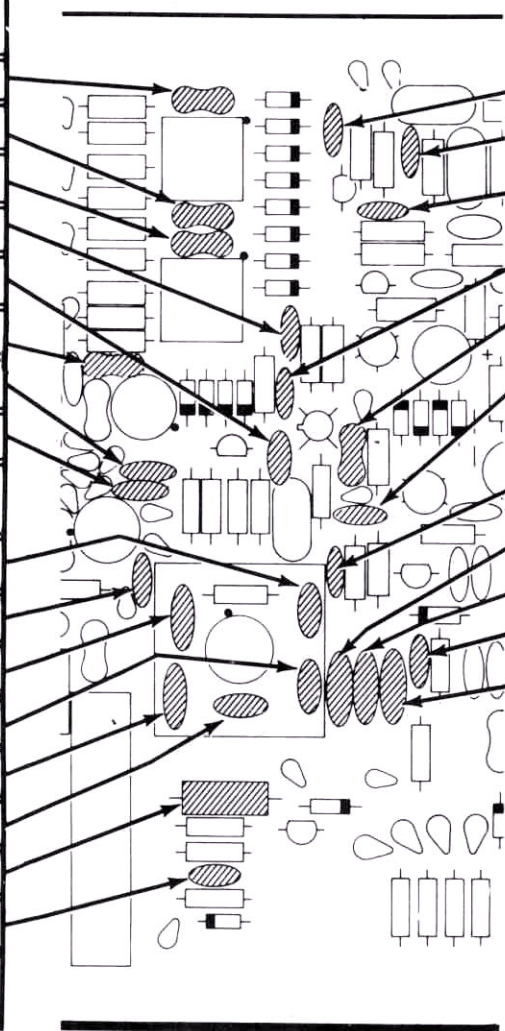

**CONTINUE**

- C125: 5 pF disc.
- C126: 10 pF disc.
- C127: 3.3 pF disc.
- C63: .05  $\mu$ F disc.
- C61: 100 pF mica.
- C62: .05  $\mu$ F disc.
- Solder the leads to the foil and cut off the excess lead lengths.
- C52: .05  $\mu$ F disc.
- C44: 510 pF disc.
- C45: 510 pF disc.
- C56: .05  $\mu$ F disc.
- C46: 510 pF disc.
- Solder the leads to the foil and cut off the excess lead lengths.

PICTORIAL 2-10

The steps performed in this Pictorial are in this area of the circuit board

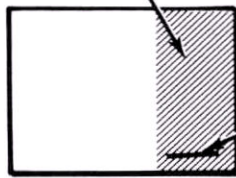

IDENTIFICATION DRAWING

**START**

- ( ) C43: .05  $\mu$ F disc.
- ( ) C109: .022  $\mu$ F Mylar.

NOTE: When you install an electrolytic capacitor, always connect the lead at the positive (+) end of the capacitor to the positive (+) marked point on the circuit board. Be careful, only the negative end of the capacitor may be marked.

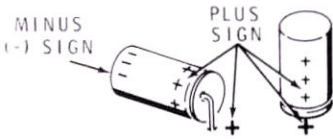

- ( ) C42: 2  $\mu$ F electrolytic.
- ( ) C38: 2  $\mu$ F electrolytic.
- ( ) C128: .05  $\mu$ F disc.
- ( ) C59: .05  $\mu$ F disc.
- ( ) C57: .05  $\mu$ F disc.
- ( ) Solder the leads to the foil and cut off the excess lead lengths.
- ( ) C23: .05  $\mu$ F disc.
- ( ) C21: .05  $\mu$ F disc.
- ( ) C17: .05  $\mu$ F disc.
- ( ) C14: .05  $\mu$ F disc.
- ( ) C1: 68 pF mica.
- ( ) C4: 68 pF mica.
- ( ) C2: .05  $\mu$ F disc.
- ( ) C5: .05  $\mu$ F disc.
- ( ) Solder the leads to the foil and cut off the excess lead lengths.

**CONTINUE**

NOTE: In the following four steps, be sure you position each capacitor so its shaded end is toward the banded end of the outline on the circuit board, as shown.

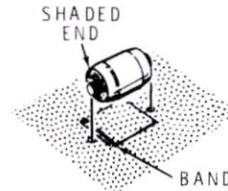

- ( ) C36: 1000 pF polystyrene.
- ( ) C37: 1000 pF polystyrene.
- ( ) C34: 1800 pF polystyrene.
- ( ) C35: 1800 pF polystyrene.
- ( ) C29: .05  $\mu$ F disc.
- ( ) C28: .05  $\mu$ F disc.
- ( ) C25: 10 pF disc.
- ( ) Solder the leads to the foil and cut off the excess lead lengths.
- ( ) C15: 47 pF mica.
- ( ) C18: 75 pF mica.
- ( ) C13: .05  $\mu$ F disc.
- ( ) C12: 3.3 pF disc.
- ( ) RFC1: 350  $\mu$ H choke (#45-82). CAUTION: Bend the leads toward the slot in the core.
- ( ) C11: .05  $\mu$ F disc.
- ( ) C8: .05  $\mu$ F disc.
- ( ) Solder the leads to the foil and cut off the excess lead lengths.

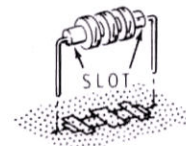

PICTORIAL 2-11

The steps performed in this Pictorial are in this area of the circuit board.

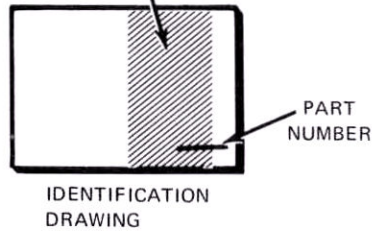

**START**

NOTE: When you install a transistor, line up the flat or tab on the transistor with the outline of the flat or tab on the circuit board. Then insert the leads in the corresponding holes in the circuit board. Position it 1/4" above the circuit board; then solder the leads to the foil and cut off the excess lead lengths.

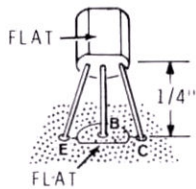

( ) Q6: MPS-6521 transistor (#417-172).

Install two MPS-A20 transistors (#417-801).

( ) Q14.

( ) Q7.

( ) Q5: MPS-A20 transistor (#417-801).

( ) Q4: 40673 transistor (#417-240).

MAY OR MAY NOT HAVE A SHORTING WIRE

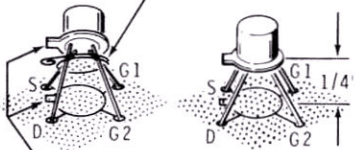

LOCATING TAB

( ) If the transistor just installed has a shorting wire, as shown in the above drawing, remove it from the transistor leads.

( ) Q3: MPS-A20 transistor (#417-801).

( ) Q1: MPF-105 transistor (#417-169).

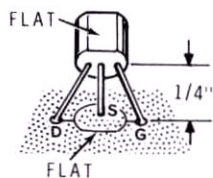

FLAT

( ) Q2: MPF-105 transistor (#417-169).

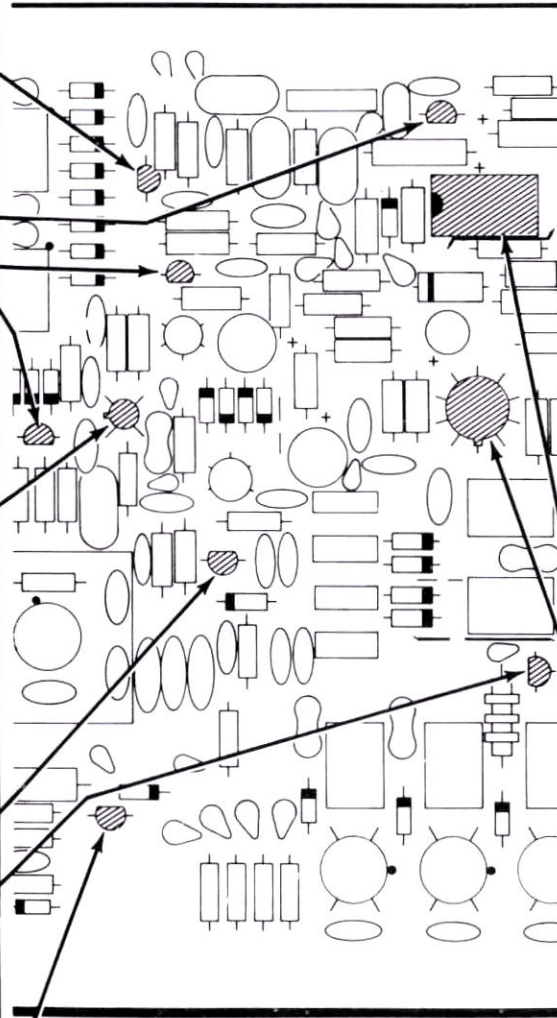

PICTORIAL 2-12

**CONTINUE**

NOTE: The indexed (pin 1) end of inline integrated circuits may be marked in a number of ways such as a notch, triangle, dot, the numeral 1, etc.

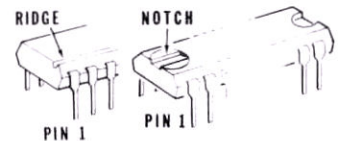
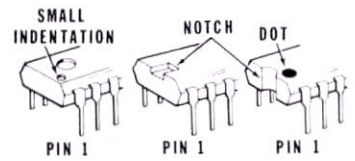

Be sure you install the IC so its indexed end is toward the index mark printed on the circuit board.

Before you apply downward pressure to an IC, make sure each IC pin is centered in its proper socket hole. Handle IC's with care as their pins are very easily bent.

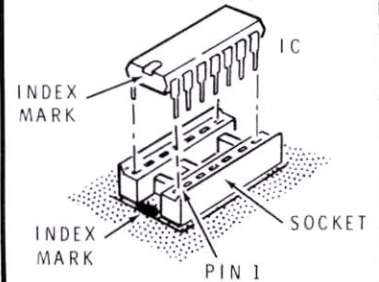

( ) IC2: LM3900 integrated circuit (#442-71).

( ) IC1: MC1496G integrated circuit (#442-96). Line up the tab on the IC with the outline of the tab on the circuit board; then insert the leads in their respective holes, 1 through 10, on the circuit board. Solder the leads to the foil and cut off the excess lead lengths.

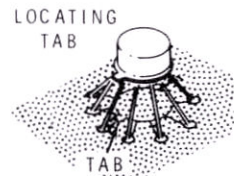



The steps performed in this Pictorial are in this area of the circuit board.

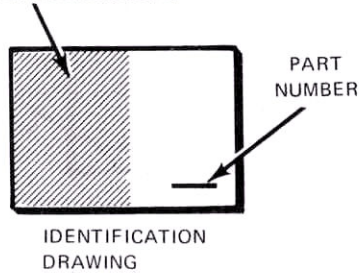

**START**

( ) Q12: MPS-A20 transistor (#417-801).

( ) Q13: X29A829 transistor (#417-201).

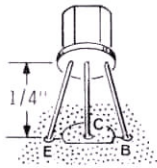

( ) Q11: S2091 transistor (#417-116).

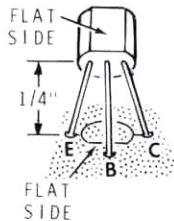

( ) Q8: MPS6521 transistor (#417-172).

( ) Q9: 2N4427 transistor (#417-880). Place a ferrite bead on the B (base) lead. Then mount the transistor as shown.

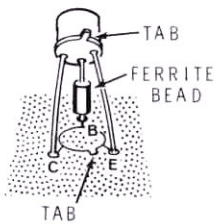

**CONTINUE**

NOTE: When you install an electrolytic capacitor, always connect the lead at the positive (+) end of the capacitor to the positive (+) marked point on the circuit board. Be careful, only the negative end of the capacitor may be marked.

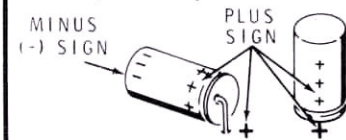

( ) C92: 10  $\mu$ F electrolytic.

( ) R68: 50 k $\Omega$  control (#10-222).



( ) C91: 2  $\mu$ F electrolytic.

( ) Solder the leads to the foil and cut off the excess lead lengths.

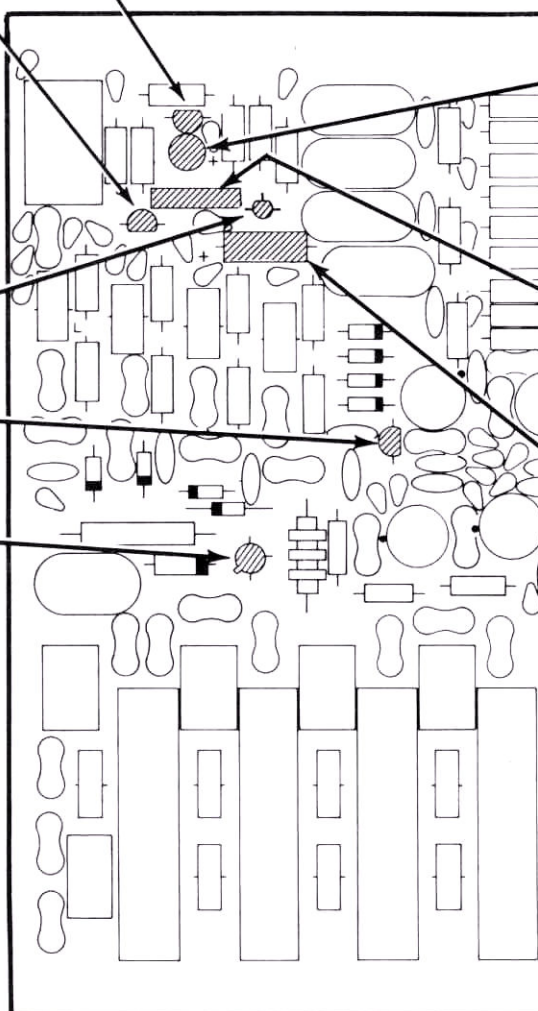

**PICTORIAL 2-13**

The steps performed in this Pictorial are in this area of the circuit board.

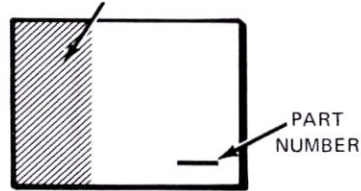

IDENTIFICATION DRAWING

**START**

FOR GOOD SOLDER CONNECTIONS, YOU MUST KEEP THE SOLDERING IRON TIP CLEAN. WIPE IT OFTEN WITH A DAMP SPONGE OR CLOTH.



NOTE: When you install a coil in the following steps, keep it within the outline on the circuit board. Solder the leads to the foil and cut off the excess lead lengths as each coil is installed.



- ( ) 9  $\mu$ H coil (#40-1797) at L22.
- ( ) 4.2  $\mu$ H coil (#40-1798) at L23.
- ( ) 26  $\mu$ H choke (#45-62) at RFC3. Bend the leads toward the slot as shown.
- ( ) C93: .47  $\mu$ F Mylar.
- ( ) Solder the leads to the foil and cut off the excess lead lengths.
- ( ) L26: 15.5  $\mu$ H coil (#40-1882).
- ( ) L27: 27.5  $\mu$ H coil (#40-1791).
- ( ) L29: 7  $\mu$ H coil (#40-1726).

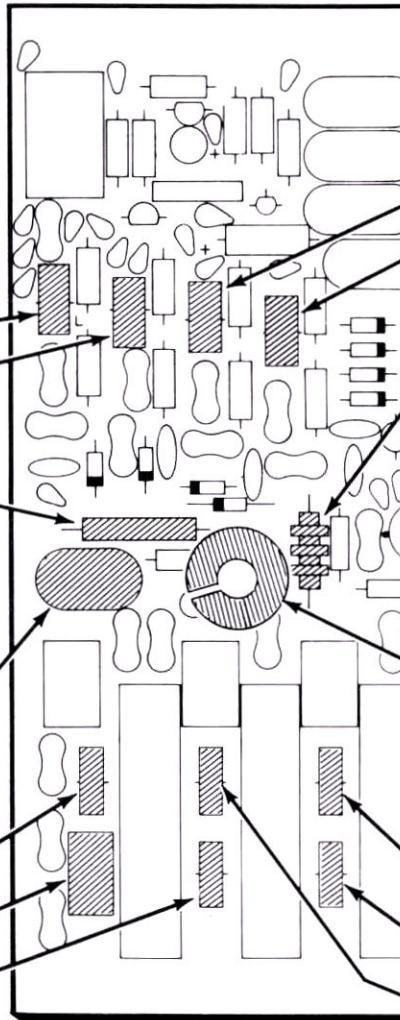
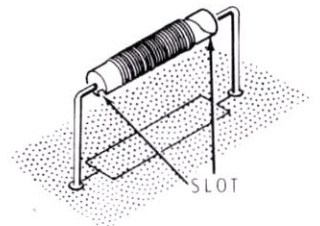

**CONTINUE**

- ( ) L24: 1.8  $\mu$ H coil (#40-1792).
- ( ) L25: 1.3  $\mu$ H coil (#40-1800).
- ( ) RFC2: 350  $\mu$ H choke (#45-82). CAUTION: Bend the leads toward the slot in the core.
- ( ) Place heat sink (#215-45) on transistor Q9 as shown.
- ( ) L31: 2.5  $\mu$ H coil (#40-1609).
- ( ) L32: 2.5  $\mu$ H coil (#40-1609).
- ( ) L28: 7  $\mu$ H coil (#40-1726).

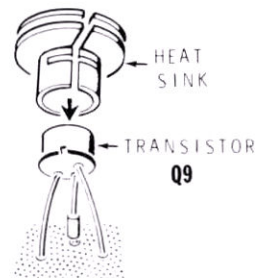
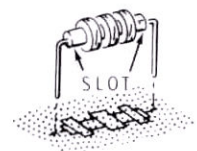

PICTORIAL 2-14

**START** →

( ) Locate a 10 kΩ (brown-black-orange) resistor, and coil #40-1794.

( ) Refer to the following drawing and solder the 10 kΩ resistor between the lugs of the coil. NOTE: Be sure you mount the resistor so the color dot on the coil is positioned as shown.

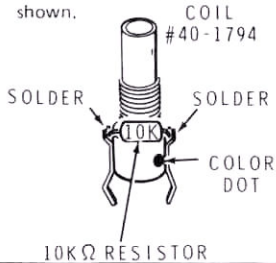

The steps performed in this Pictorial are in this area of the circuit board.

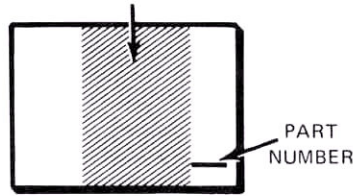

IDENTIFICATION DRAWING

NOTES:

1. In the following steps, be sure you position the color dot on the coil toward the dot of the coil outline on the circuit board.
2. Solder the pins to the foil as you install each part.

( ) L13/R50: Mount the coil-resistor combination at L13.

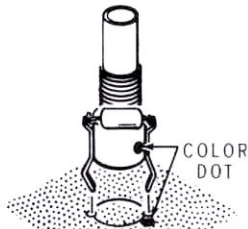

- ( ) L14: 4 μH coil (#40-1795).
- ( ) L15: 1.3 μH coil (#40-1796).
- ( ) L16: 1.3 μH coil (#40-1796).

( ) L9: 5 μH coil (#40-1802).

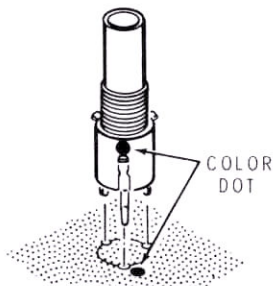

( ) L33: 1.3 μH toroid coil (#40-1800).

( ) L34: 1.3 μH toroid coil (#40-1800).

( ) Solder the leads to the foil and cut off the excess lead lengths.

**CONTINUE** →

( ) L17/L18: 80/40 meter heterodyne oscillator coil (#40-1803).

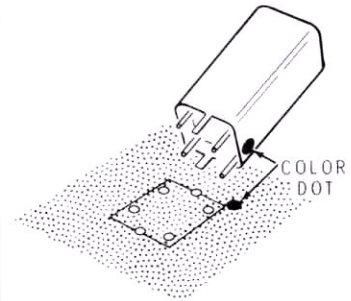

( ) L19/L21: 20/15 meter heterodyne oscillator coil (#40-1804).

( ) L12: 15 μH toroid coil (#40-1050). Match the color dot on the wide space on the circuit board.

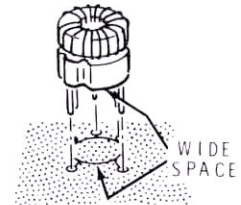

( ) L11: 15 μH toroid coil (#40-1050).

( ) Be sure the shield cans of coils L17, L18, L19, and L21 do not touch the leads of the resistors at the left side of the coils. If necessary, use a small screwdriver and very carefully press the bottom edge of each shield just far enough away from the resistor leads so they do not touch.

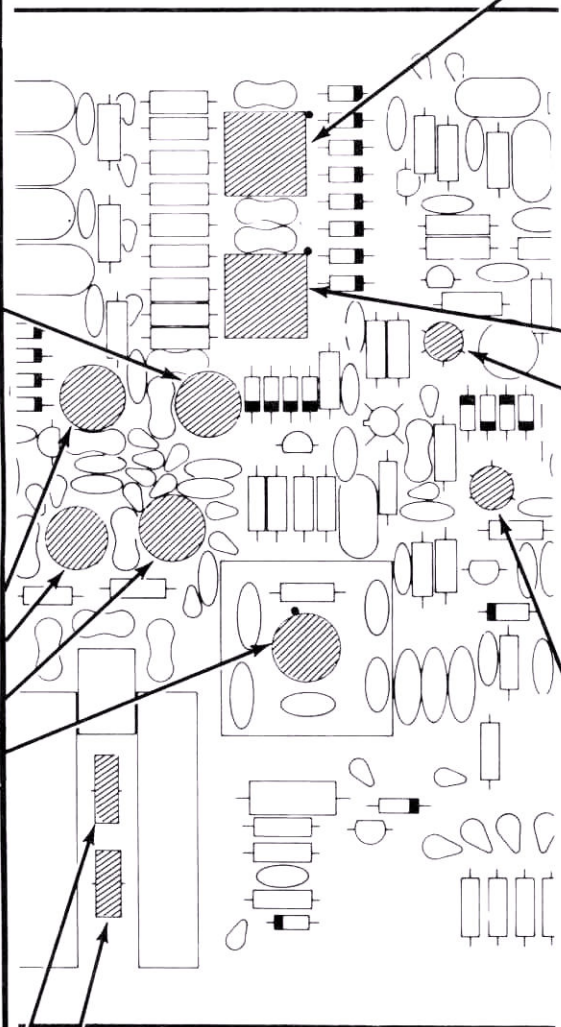

PICTORIAL 2-15

The steps performed in this Pictorial are in this area of the circuit board.

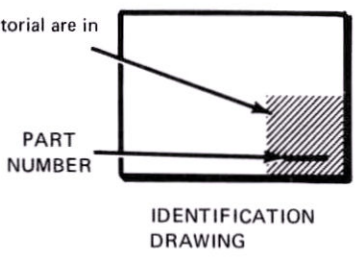

**START** ↘

**FOR GOOD SOLDER CONNECTIONS, YOU MUST KEEP THE SOLDERING IRON TIP CLEAN. WIPE IT OFTEN WITH A DAMP SPONGE OR CLOTH.**



NOTE: When you install a coil in the following steps, keep it within the coil outline on the circuit board. Solder the leads to the foil and cut off the excess lead lengths.

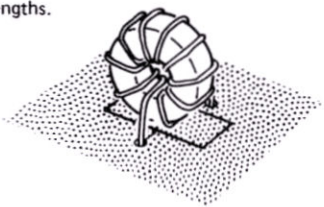

- ( ) L8: 1.3  $\mu$ H toroid coil (#40-1800).
- ( ) L7: 1.8  $\mu$ H toroid coil (#40-1792).
- ( ) L6: 4.2  $\mu$ H toroid coil (#40-1798).
- ( ) L5: 15.5  $\mu$ H toroid coil (#40-1882).

**NOTES:**

1. You will install four trimmer capacitors on the circuit board in the following steps. Note that there are two different values of trimmers.
2. Some of the trimmer lugs have two or more leaves. When you install the trimmers, make sure all of the lug leaves go through the circuit board.
3. IT IS VERY IMPORTANT to solder the correct trimmer lug to the correct foil. One lug on each trimmer will be called the ground lug (G). This is the lug that is connected to the metal plate directly under the screw on the trimmer.

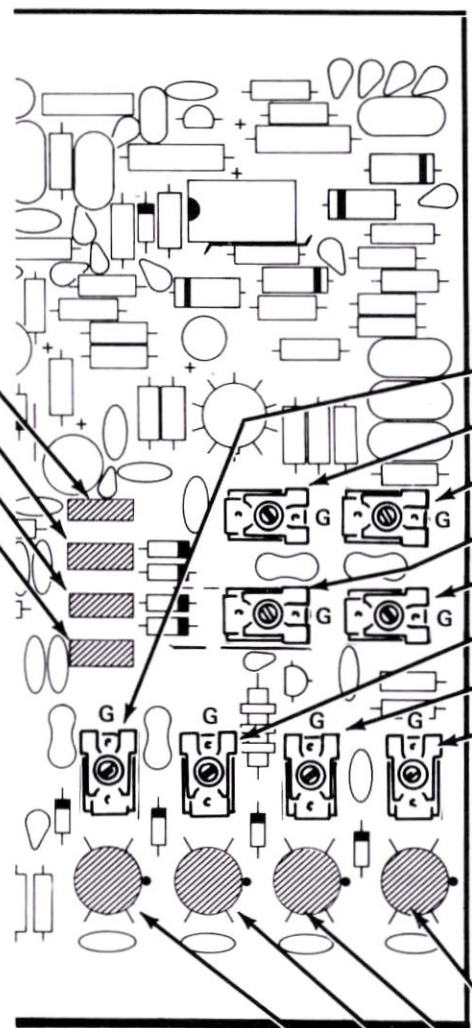
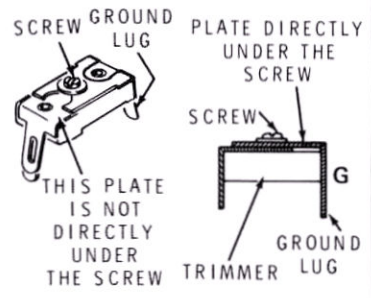

**PICTORIAL 2-16**

**CONTINUE** ↘

NOTES: (cont'd.)

4. Make sure that each trimmer capacitor is properly positioned and soldered to the foil. If a trimmer lug has more than one leaf, make sure all leaves are soldered.

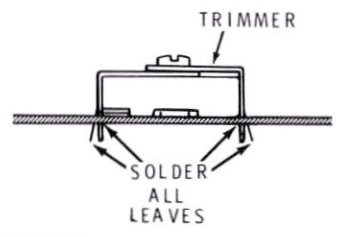

- ( ) C3: 8-60 pF trimmer (#31-52).
- ( ) C24: 8-60 pF trimmer (#31-52).
- ( ) C22: 8-60 pF trimmer (#31-52).
- ( ) C19: 4-40 pF trimmer (#31-54).
- ( ) C16: 4-40 pF trimmer (#31-54).
- ( ) C6: 4-40 pF trimmer (#31-54).
- ( ) C7: 8-60 pF trimmer (#31-52).
- ( ) C9: 8-60 pF trimmer (#31-52).

Install four toroid coils as shown below.

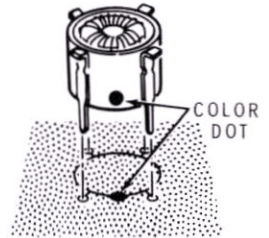

- ( ) L4: 1.8  $\mu$ H toroid coil (#40-1788).
- ( ) L3: 1.8  $\mu$ H toroid coil (#40-1788).
- ( ) L2: 4.7  $\mu$ H toroid coil (#40-1787).
- ( ) L1: 13  $\mu$ H toroid coil (#40-1786).
- ( ) Solder the lugs to the foil.

The steps performed in this Pictorial are in this area of the circuit board.

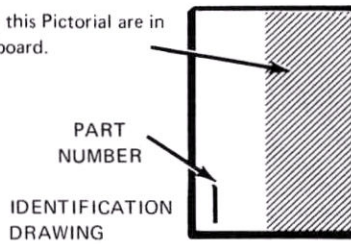

**CONTINUE** ▾

NOTE: In the following five steps, solder the pins to the foil as you install each part.

- ( ) RY1: Relay (#69-47). CAUTION: Do not bend any of the mechanical parts on the relay.

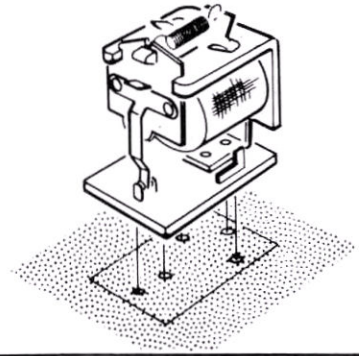

- ( ) Y1: 12.395 MHz crystal (#404-207).



- ( ) Y2: 15.895 MHz crystal (#404-208).

- ( ) Y3: 22.895 MHz crystal (#404-209).

- ( ) Y4: 29.895 MHz crystal (#404-210).

Install eight .1  $\mu$ F Mylar capacitors.

- ( ) C74.
- ( ) C112.
- ( ) C111.
- ( ) C113.
- ( ) C27.
- ( ) C26.
- ( ) C31.
- ( ) C39.

- ( ) Solder the leads to the foil and cut off the excess lead lengths.

**START** ▾

Note the different position of the circuit board in this Pictorial.

NOTE: When you install an electrolytic capacitor, always connect the lead at the positive (+) end of the capacitor to the positive (+) marked point on the circuit board. Be careful, only the negative end of the capacitor may be marked.

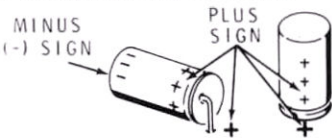

- ( ) C41: 100  $\mu$ F electrolytic.
- ( ) C32: 100  $\mu$ F electrolytic.
- ( ) C33: 10  $\mu$ F electrolytic.
- ( ) Solder the leads to the foil and cut off the excess lead lengths.

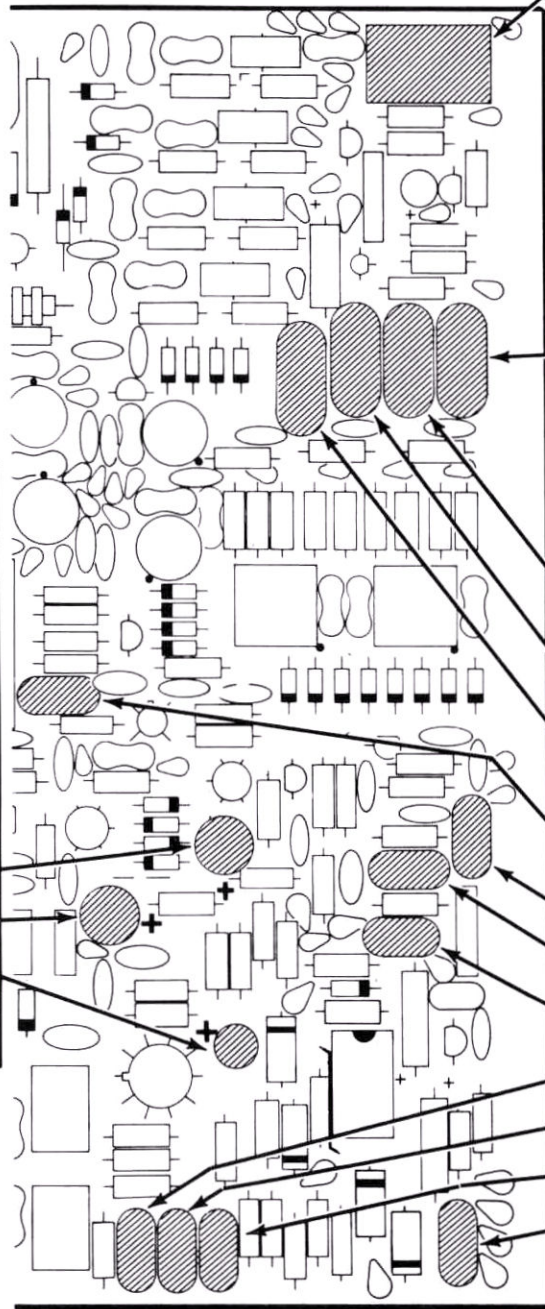

PICTORIAL 2-17

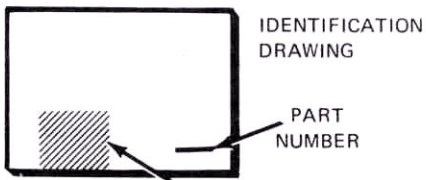

The steps performed in this Pictorial are in this area of the circuit board.

**START**

**FOR GOOD SOLDER CONNECTIONS, YOU MUST KEEP THE SOLDERING IRON TIP CLEAN. WIPE IT OFTEN WITH A DAMP SPONGE OR CLOTH.**

**NOTE:** There is a spring at one end of the pushbutton switch assembly. (See inset drawing.) When you perform the next two steps, be sure you position the switch assembly so its spring end is toward your left as shown.

- ( ) Position the pushbutton switch assembly so its spring end is toward your left as shown in Detail 2-18A.
- ( ) Very carefully cut the indicated pins off each of the four switches. Cut them as close as possible to the body of each switch.

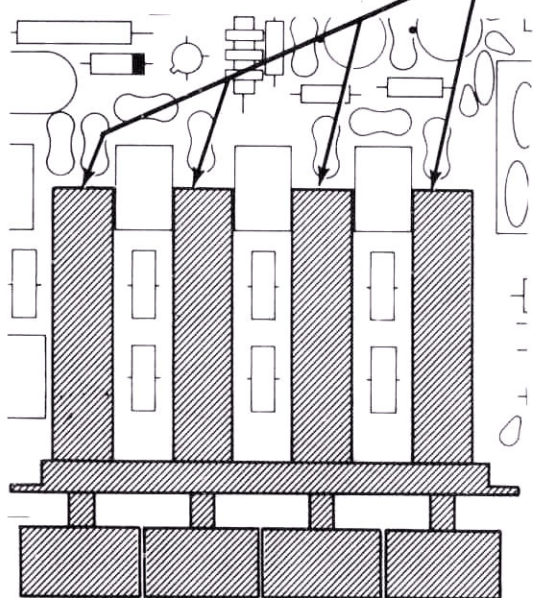
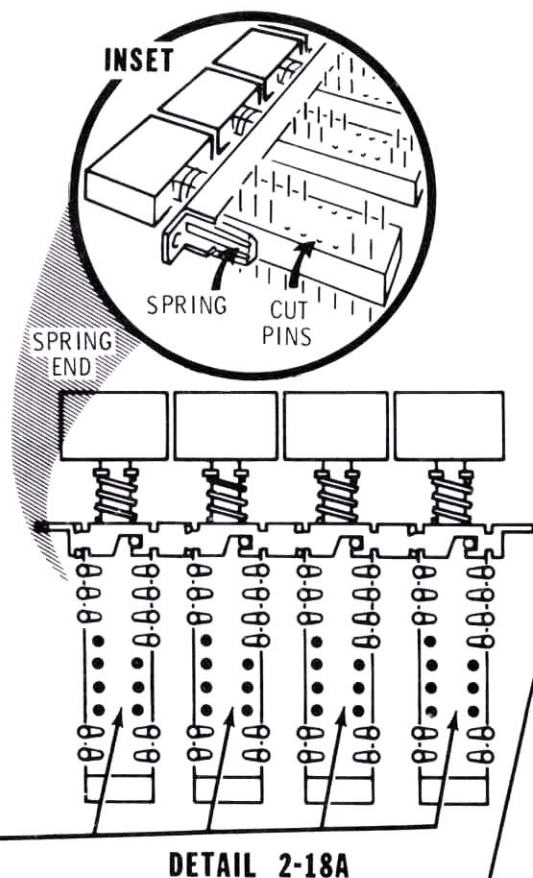

PICTORIAL 2-18

**CONTINUE**

- ( ) Turn the switch assembly over and line up the remaining pins with their respective holes in the circuit board.

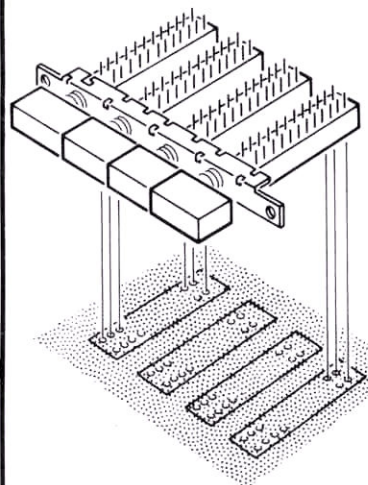

- ( ) Start the pins into the circuit board holes. Then press the switch assembly tight against the circuit board. Also, make sure the assembly is parallel with the circuit board. Then turn the assembly over and solder two lugs on each end of the switch assembly. Check the switch assembly to make sure it is straight. If the assembly is straight, solder the other switch lugs. Cut off the excess lugs from the foil side of the board.

**CIRCUIT BOARD CHECKOUT**

Carefully inspect the circuit board for the following conditions.

- ( ) Unsoldered connections.
- ( ) "Cold" solder connections.
- ( ) Solder bridges between foil patterns.
- ( ) Protruding leads which could touch together.
- ( ) Transistors for the proper type and installation.
- ( ) Electrolytic capacitors for the correct position of the positive (+) end.
- ( ) Diodes for the correct position of the banded end.

**FINISH**

## CIRCUIT BOARD WIRING

### NOTES:

- In the following steps, you will use the 5-wire cable supplied with the kit to prepare four multiwire cables. Each cable will be connected to the circuit board as soon as it is prepared.

**CAUTION:** When you prepare a multiwire cable in the following steps, grip the cable securely when you remove insulation from one of the wires. This will prevent you from pulling one of the wires out of the cable.

- When you prepare the ends of the cable wires, cut each wire to the length indicated in the appropriate Detail and remove 1/4" of insulation from each end of each wire. Then twist the strands and apply a small amount of solder to the wire ends to hold the strands together.
- Solder each wire to the foil as it is connected to the circuit board. Then cut off the excess wire lengths.

Refer to Pictorial 3-1 in the Illustration Booklet for the following steps.

- ( ) Refer to Detail 3-1A and prepare an 8" cable as shown.

Connect the wires at the shorter prepared end of this cable to the following circuit board holes.

- ( ) White to hole NN.
- ( ) Green to hole MM.
- ( ) Red to hole LL.
- ( ) Black to hole KK.

**NOTE:** In the following steps, (NS) means not to solder because another wire (or wires) will be added later. The letter S with a number, such as (S-2), means to solder the connection. The number that follows the letter S indicates the number of wires at that connection.

Connect the wires at the free end of the 8" cable to the pushbutton switch assembly as follows. Wrap each wire around the pin so it makes a secure mechanical connection before you solder the wire to the pin.

- ( ) White to switch SW4 pin 9 (NS).
- ( ) Green to switch SW3 pin 9 (NS).
- ( ) Red to switch SW2 pin 9 (NS).
- ( ) Black to switch SW1 pin 9 (NS).

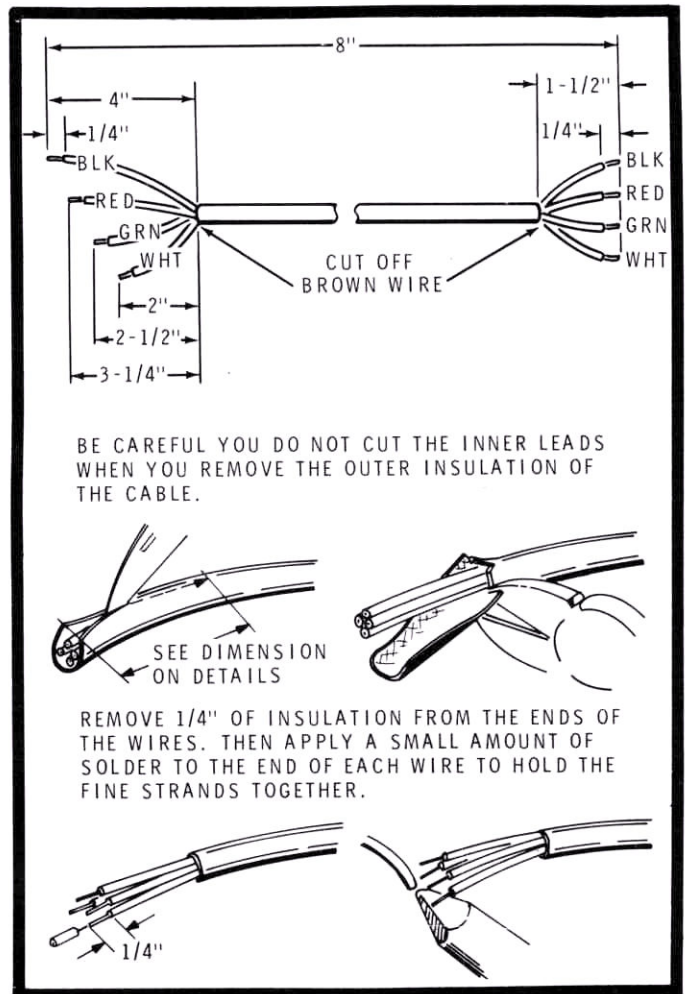

Detail 3-1A

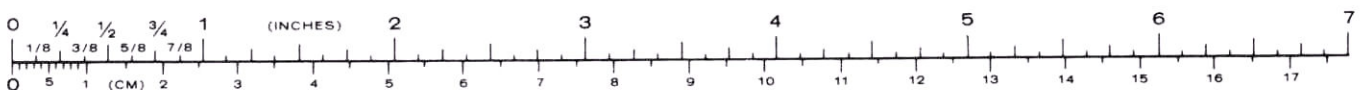

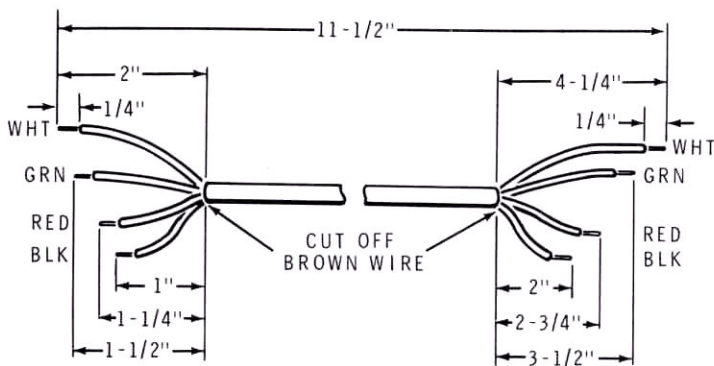

Detail 3-1B

- ( ) Refer to Detail 3-1B and prepare an 11-1/2" cable as shown.

Connect the wires at the shorter prepared end of the cable to the following circuit board holes.

- ( ) Black to hole N.
- ( ) Red to hole P.
- ( ) Green to hole Q.
- ( ) White to hole R.

At the other end of the cable, connect the wires to the pushbutton switch assembly as follows:

- ( ) Black to SW1 pin 5 (S-1).
- ( ) Red to SW2 pin 5 (S-1).
- ( ) Green to SW3 pin 5 (S-1).
- ( ) White to SW4 pin 5 (S-1).
- ( ) Cut an 8-1/2" length off the remaining length of 5-wire cable. Then carefully remove all of the outer insulation from the 8-1/2" length. These cable wires will be used in the following steps.

NOTE: When you prepare a stranded wire, cut it to the length specified in the step and remove 1/4" of insulation from each end. Then twist the strands and apply a small amount of solder to the wire ends to hold the strands together.

You may prefer to prepare wires ahead of time, as in the following step. The wires are listed in the order in which they are used. Save the remaining wires for use later.

- ( ) Prepare the following wires:

2-1/2" white	3-1/2" red
2-1/2" white	5" black
2-1/2" green	2-3/4" green

- ( ) Connect a 2-1/2" white wire between circuit board holes 4 (S-1) and 4 (S-1).
- ( ) Connect a 2-1/2" white wire from switch SW4 pin 9 (S-2) to circuit board hole 8 (S-1).
- ( ) Connect a 2-1/2" green wire from switch SW3 pin 9 (S-2) to circuit board hole 7 (S-1).
- ( ) Connect a 3-1/2" red wire from switch SW2 pin 9 (S-2) to circuit board hole 6 (S-1).
- ( ) Connect a 5" black wire from switch SW1 pin 9 (S-2) to circuit board hole 5 (S-1).
- ( ) Connect a 2-3/4" green wire between circuit board holes 3 (S-1) and 3 (S-1).
- ( ) Position the cable wires connected to the pushbutton switch assembly down between the switch pins and against the body of the switches. Position the circuit board wires as shown on the Pictorial.





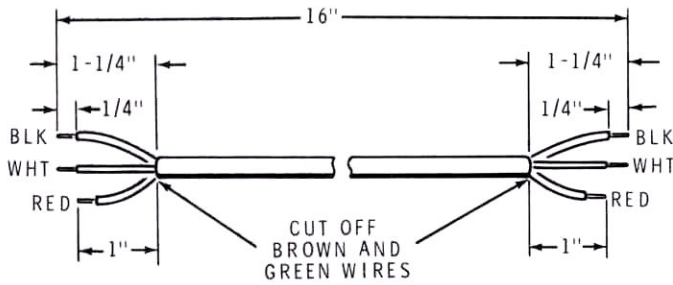

**Detail 3-1C**

**NOTES:**

1. When the hardware is called in a step, only the screw size will be given. For instance, if 6-32 x 1/4" hardware is called for, it means to use a 6-32 x 1/4" screw, one or more #6 lockwashers, and a 6-32 nut. The Detail, inset drawing, or Pictorial referred to in the steps will show the proper number of lockwashers and the type of screw to use.
  2. Use the plastic nut starter supplied with the kit to hold and start 6-32 and 4-40 nuts on screws.
- ( ) Refer to Detail 3-1C and prepare a 16" cable. At one end of the cable, connect the wires to the following circuit board holes.
  - ( ) Red to hole HH.
  - ( ) Black to hole JJ.
  - ( ) White to hole EE.
  - ( ) Refer to the inset drawing on Pictorial 3-1 and mount an angle bracket (#204-1844) on the upper edge of the circuit board. Use 6-32 x 1/4" hardware at the three locations shown. Tighten the hardware only finger tight.
  - ( ) Move the angle bracket as far as it will go away from the edge of the circuit board. Then tighten the screws.

The other end of the cable will be connected later.

- ( ) Refer to Detail 3-1D and prepare an 11" cable.

At the longer prepared end, connect the wires to the following circuit board holes.

- ( ) White to hole PP.
- ( ) Black to hole CC.

The green wire, and the wires at the other end of the cable, will be connected later.

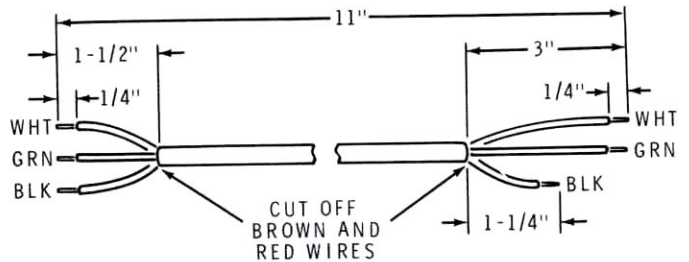

**Detail 3-1D**

Refer to Pictorial 3-2 in the Illustration Booklet for the following steps.

- ( ) Connect a 2-1/2" red wire between circuit board holes 2 (S-1) and 2 (S-1).
- ( ) Connect a 3-1/2" black wire between circuit board holes 1 (S-1) and 1 (S-1).

**NOTES:**

1. All of the shielded cables used in this kit will have their ends prepared and dimensioned as specified in Detail 3-2A. **CAUTION:** Hold each cable as shown when you prepare its ends. This will prevent you from pulling the inner lead out of the cable when you remove outer or inner insulation.
2. The step that directs you to prepare a shielded cable will specify its length.

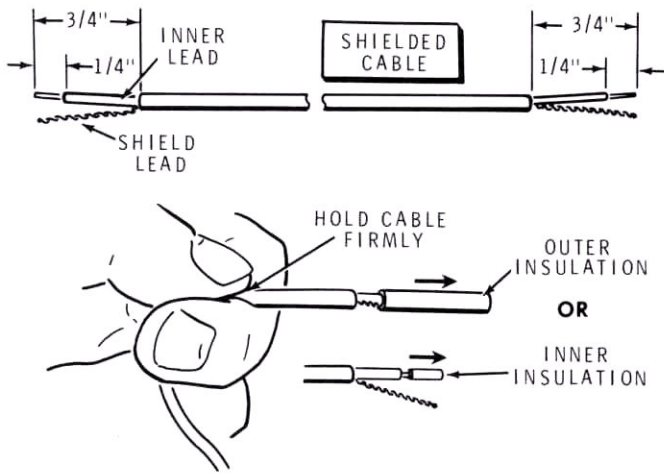

**Detail 3-2A**

- ( ) Refer to Detail 3-2A and prepare a 4" shielded cable.
- ( ) At one end of this cable, connect the shield lead to hole S (S-1) and the inner lead to hole C (S-1). **NOTE:** These two holes are near the center of the circuit board.
- ( ) At the other end of the cable, carefully cut off only the shield lead. Then connect the inner lead to hole H (S-1).
- ( ) Refer to Detail 3-2A and prepare four 7" shielded cables.
- ( ) At one end of a 7" shielded cable, wrap the inner lead around SW1 pin 3 (S-1) and the shield lead around pin 4 (S-1).

**NOTE:** Be very careful when you connect the shielded cables in the following steps. Do not allow the shield wires to touch adjacent coil or switch lugs. Position the leads down between the coils; then carefully wrap the leads around the coil lugs. Solder the leads to the lugs and cut off the excess lead lengths. **CAUTION:** Use only enough heat and solder to make a good connection.

- ( ) At the free end of the 7" cable, wrap the shield lead around coil L1 lug 2 (S-1) and the inner lead around lug 1 (S-1).
- ( ) At one end of another 7" cable, wrap the inner lead around SW2 pin 3 (S-1) and the shield lead around pin 4 (S-1).
- ( ) At the other end of the cable, wrap the shield lead around coil L2 lug 2 (S-1) and the inner lead around lug 1 (S-1).
- ( ) At one end of another 7" cable, wrap the inner lead around SW3 pin 3 (S-1) and the shield lead around pin 4 (S-1).
- ( ) At the other end of the cable, wrap the shield lead around coil L3 lug 2 (S-1) and the inner lead around lug 1 (S-1).



- ( ) At one end of another 7" cable, wrap the inner lead around SW4 pin 3 (S-1) and the shield lead around pin 4 (NS).
- ( ) At the other end of the cable, wrap the shield lead around L4 lug 2 (S-1) and the inner lead around lug 1 (S-1).
- ( ) Refer to Detail 3-2A and prepare a 5-1/2" shielded cable.
- ( ) At one end of the cable, wrap the inner lead around SW4 pin 2 (NS) and the shield lead around lug 4 (S-2). The other end of this cable will be connected later.
- ( ) Refer to Detail 3-2A and prepare a 13-1/2" shielded cable.
- ( ) At one end of this cable, connect the shield lead to the indicated circuit board hole S (S-1) and the inner lead to hole M (S-1). The other end of this cable will be connected later.
- ( ) Refer to Detail 3-2A and prepare a 7" shielded cable.
- ( ) At one end of this cable, connect the shield lead to the other circuit board hole marked S (S-1) and the inner lead to hole L (S-1). The other end of this cable will be connected later.

- ( ) Connect an 8-1/2" wire between circuit board holes J (S-1) and WW (S-1).
- ( ) Connect a 6-1/2" wire between circuit board holes V (S-1) and V (S-1).
- ( ) Install a 1-1/2" wire at the location marked JUMPER. NOTE: Position this wire over R22, the 470 kΩ (yellow-violet-yellow) resistor, as shown.
- ( ) Connect a 3-1/2" wire between circuit board holes U (S-1) and U (S-1).
- ( ) Connect a 10" wire between circuit board holes K (S-1) and B (S-1).
- ( ) Connect an 8" wire from circuit board hole XX (S-1) to switch SW1 pin 6 (NS).
- ( ) Connect a 4" wire from circuit board hole D (S-1) to switch SW4 pin 8 (NS).
- ( ) Connect a 2-1/2" wire from circuit board hole T (S-1) to SW4 pin 6 (NS).
- ( ) Prepare the following yellow wires:

2"	2-1/2"	2"
2"	2-1/2"	2"
2"	2-1/2"	2"

Refer to Pictorial 3-3 in the Illustration Booklet for the following steps.

NOTES:

1. Use yellow hookup wire when you perform the following steps. After you connect a wire on the circuit board, solder the wire to the foil and cut off the excess wire lengths.
  2. When you connect a wire to one of the pins of the pushbutton switch assembly, wrap the wire around the pin so it makes a secure mechanical connection before you apply any solder.
- ( ) Prepare the following wires:

8-1/2"	10"
6-1/2"	8"
1-1/2"	4"
3-1/2"	2-1/2"

Connect wires between the pins of the pushbutton switch assembly as follows:

- ( ) 2" yellow from SW1 pin 8 (S-1) to SW2 pin 8 (NS).
- ( ) 2" yellow from SW2 pin 8 (S-2) to SW3 pin 8 (NS).
- ( ) 2" yellow from SW3 pin 8 (S-2) to SW4 pin 8 (S-2).
- ( ) 2-1/2" yellow from SW1 pin 6 (S-2) to SW2 pin 6 (NS).
- ( ) 2-1/2" yellow from SW2 pin 6 (S-2) to SW3 pin 6 (NS).
- ( ) 2-1/2" yellow from SW3 pin 6 (S-2) to SW4 pin 6 (S-2).

- ( ) 2" yellow from SW4 pin 2 (S-2) to SW3 pin 2 (NS).
  - ( ) 2" yellow from SW3 pin 2 (S-2) to SW2 pin 2 (NS).
  - ( ) 2" yellow from SW2 pin 2 (S-2) to SW1 pin 2 (S-1).
  - ( ) In a similar manner, use cable ties to securely tie together the wires and/or cables at E and F.
  - ( ) Position the wires on the circuit board as shown in the Pictorial.
- ( ) Group together all of the wires and cables at D on the Pictorial. Then refer to the inset drawing and, using a cable tie as shown, tie all of the wires and cables tightly together.
- This completes the circuit board wiring. Shake out any loose wire clippings or solder splashes. Recheck the circuit board for any solder bridges between adjacent foil patterns. Then set the circuit board aside until it is called for later.

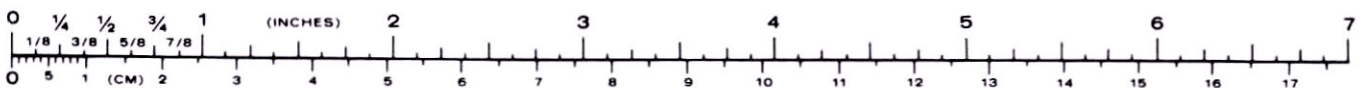

# CHASSIS

## PARTS LIST

Check the remaining parts against the following list. Make a check (✓) in the space provided as you identify each part. The illustrations show what the part looks like. Only the hardware is shown actual size.

Some parts are packaged in containers with the part number marked on the outside. Except for the initial parts check, keep these parts in their containers so they can be easily identified when they are called for in the assembly steps.

To order a replacement part, always include the PART NUMBER. Use the Parts Order Form furnished with the kit. If one is not available, see "Replacement Parts" inside the rear cover of this Manual. Your Warranty is located inside the front cover. For pricing information, refer to the separate "Heath Parts Price List."

KEY No.	QTY.	DESCRIPTION	PART No.	CIRCUIT Component No.
---------	------	-------------	----------	-----------------------

### RESISTORS-DIODES

F1	( )	2	1000 (brown-black-red) resistor.	6-102	R303, R304
F1	( )	1	47 kΩ (yellow-violet-orange) resistor.	6-473	R305
F2	( )	2	100 Ω, 2-watt (brown-black-brown) resistor	1-20-2	R306, R307
F3	( )	1	1N458 diode	56-24	D301

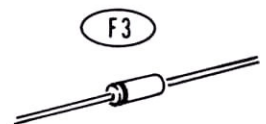
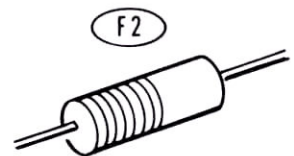
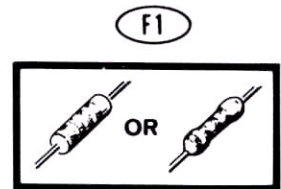

KEY No.	QTY.	DESCRIPTION	PART No.	CIRCUIT Component No.
---------	------	-------------	----------	-----------------------

**CAPACITORS**

F4 ( )	1	.05 $\mu$ F disc capacitor	21-143	C304
F5 ( )	1	.47 $\mu$ F Mylar capacitor	27-86	C305
F6 ( )	1	Preselector tuning capacitor	26-151	C301A/B
F7 ( )	1	VFO tuning capacitor	26-152	C302A/B
F8 ( )	1	Loading capacitor	26-154	C303

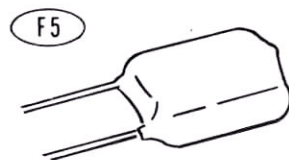
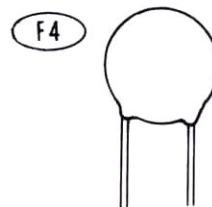

**CONTROL-SWITCH**

F9 ( )	1	10 k $\Omega$ /1000 $\Omega$ control with switch	14-17	R301, R302, S301
F10 ( )	1	Rotary switch	63-3	SW302

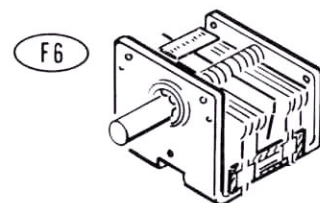

**CONNECTOR-PIN-JACK-PLUG**

F11 ( )	2	Male connector pin	432-72	
F12 ( )	2	Female connector pin	432-73	
F13 ( )	1	Chassis connector	432-94	
F14 ( )	1	Cable connector	432-95	
F15 ( )	1	Antenna socket	434-107	J302
F16 ( )	2	Antenna plug	438-4	
F17 ( )	2	Jack	436-20	J301, J303

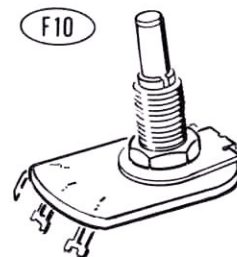
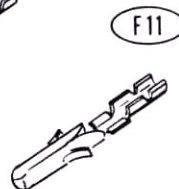
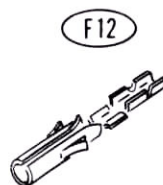
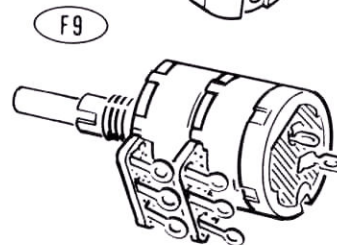
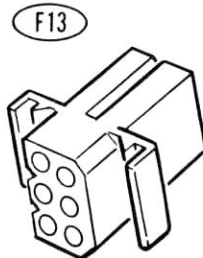
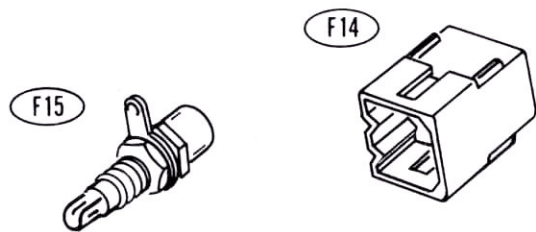
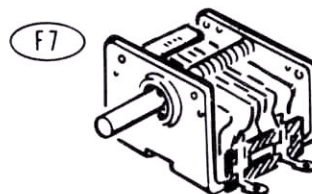

KEY No.	QTY.	DESCRIPTION	PART No.	CIRCUIT Component No.
---------	------	-------------	----------	-----------------------

## HARDWARE

NOTE: The hardware may be in more than one packet. Open all the hardware packets before you check the hardware against the Parts List.

### # 4 Hardware

G1 ( )	2	4-40 x 1/4" screw	250-52
G2 ( )	2	4-40 x 1/2" flat head screw	250-322
G3 ( )	2	4-40 nut	252-15
G4 ( )	4	#4 lockwasher	254-9

### # 6 Hardware

G5 ( )	1	6-32 x 1/8" round head screw	250-208
G6 ( )	4	6-32 x 1/8" setscrew	250-33
G7 ( )	6	6-32 x 3/16" screw	250-138
G8 ( )	4	6-32 x 1/4" screw	250-56
G9 ( )	4	6-32 x 1/4" flat head screw	250-416
G10 ( )	2	6-32 x 3/8" screw	250-89
G11 ( )	15	#6 x 1/4" sheet metal screw	250-170
G12 ( )	11	6-32 nut	252-3
G13 ( )	16	#6 lockwasher	254-1
G14 ( )	2	3/16" spacer	255-2
G15 ( )	4	#6 solder lug	259-1

### Other Hardware

G16 ( )	6	Control nut	252-7
G17 ( )	4	Control flat washer	253-10
G18 ( )	2	Fiber shoulder washer	253-16
G19 ( )	3	Control lockwasher	254-5
G20 ( )	1	Split bushing	455-11
G21 ( )	1	8-32 x 3/8" setscrew	250-1193



KEY No.	QTY.	DESCRIPTION	PART No.	CIRCUIT Component No.
---------	------	-------------	----------	-----------------------

**METAL PARTS**

H1 ( )	2	Cabinet shell	90-566-2	
H2 ( )	1	Chassis	200-1229	
H3 ( )	1	Front panel	203-1665-1	
H4 ( )	1	Rear panel	203-1710-2	
H5 ( )	1	Capacitor mounting bracket	204-1845	

**KNOBS-DIAL-WINDOW**

H6 ( )	1	Large knob	462-257	
H7 ( )	4	Small knob	462-258	
H8 ( )	1	Silver knob	462-293	
H9 ( )	1	Dial	464-65-2	
H10 ( )	1	Window	446-602-1	

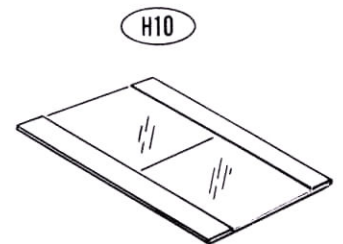
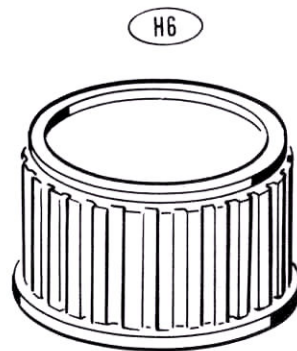
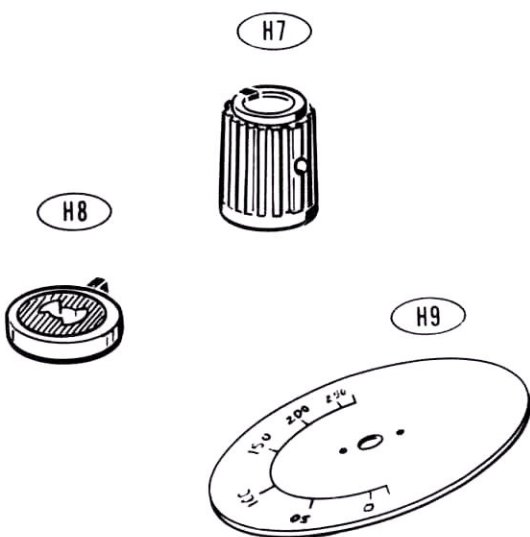
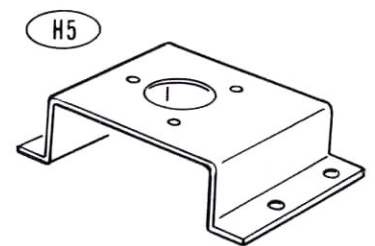
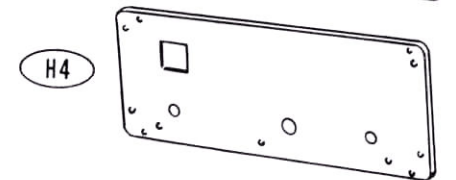
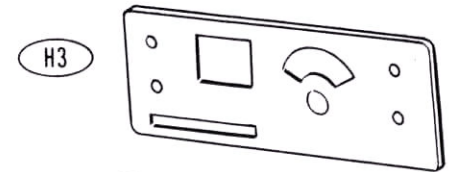
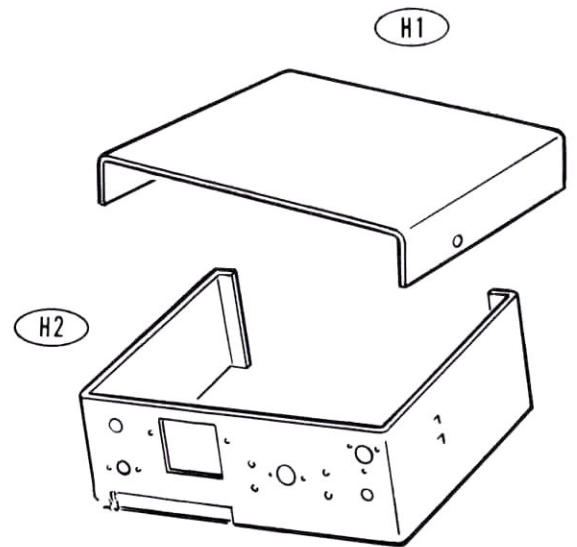



KEY No.	QTY.	DESCRIPTION	PART No.	CIRCUIT Component No.
---------	------	-------------	----------	-----------------------

**MISCELLANEOUS**

H11 ( )	1	Vernier drive	100-1608	
H12 ( )	1	Coil shield	206-502	
H13 ( )	1	Meter	407-167	
H14 ( )	1	3-lug terminal strip	431-10	
H15 ( )	4	Plastic chassis nut	75-61	
H16 ( )	1	Alignment tool, small	490-109	
H17 ( )	1	Alignment tool, large	490-1	
H18 ( )	1	Metal blade	205-778	
H19 ( )	4	Plastic foot	261-34	
( )	5'	Red wire	344-3	
( )	5'	Black wire	344-2	

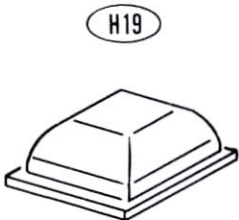
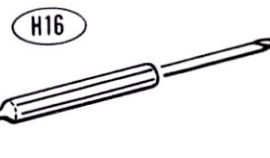
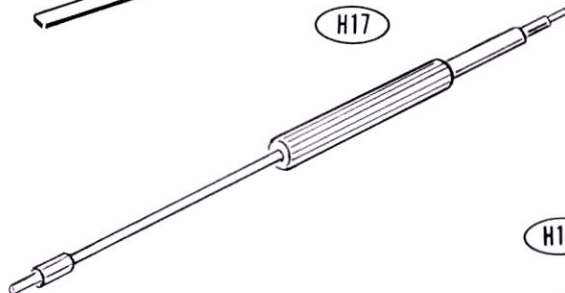
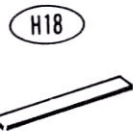
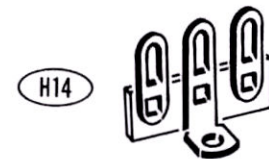
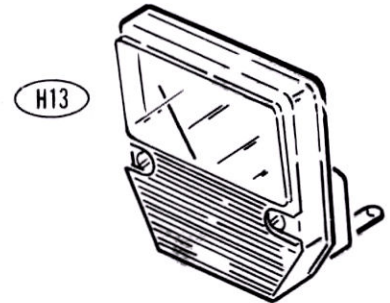
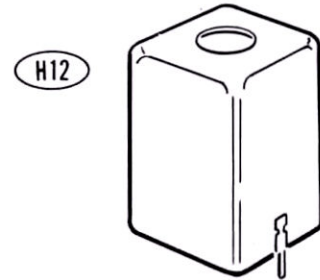
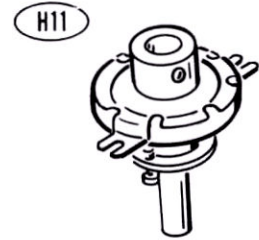

## STEP-BY-STEP ASSEMBLY

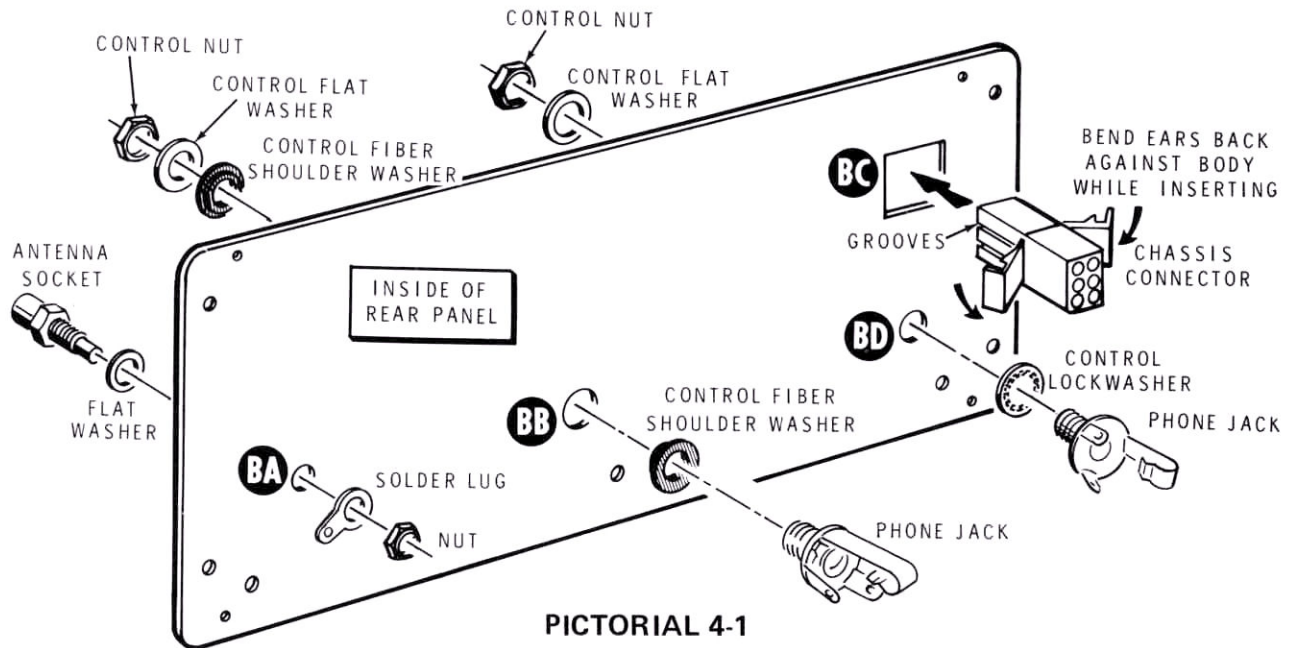

### REAR PANEL PARTS MOUNTING

Refer to Pictorial 4-1 for the following steps.

- ( ) Install an antenna socket in hole BA with the hardware supplied with the socket. Position the lug as shown; then bend it away from the panel. **CAUTION:** Do not overtighten the hardware, as you could break the socket.
- ( ) Install a phone jack in hole BB with two fiber shoulder washers, a control flat washer, and a control nut. Position the jack as shown in the Pictorial. **CAUTION:** Be sure the shoulders of the fiber washers are properly seated in the panel before you tighten the hardware.
- ( ) Install a phone jack in hole BD with a control lockwasher, control flat washer, and control nut. Position the jack as shown in the Pictorial. Also, note the difference in position between this jack and jack BB.
- ( ) Install the chassis connector in hole BC. **CAUTION:** Be sure you install it so its grooves are positioned as shown in the Pictorial.

### MOUNTING AND WIRING REAR PANEL

Refer to Pictorial 4-2 in the Illustration Booklet for the following steps.

- ( ) Mount the rear panel assembly to the angle bracket on the circuit board with #6 x 1/4" sheet metal screws at the three indicated locations.

- ( ) Prepare the following yellow wires:

1-1/2"	4"
1-1/4"	4"
3-1/2"	3-1/2"
7"	2"

Connect wires from the circuit board to the parts on the rear panel as follows:

- ( ) 1-1/2" yellow wire from hole X (S-1) to socket BA lug 1 (S-1).
- ( ) 1-1/4" yellow wire from relay RY1 lug 2 (S-1) to socket BA lug 2 (S-1).



## NOTES:

1. If you use a keyer such as the Heathkit Model HD-1410, wire jack BB as directed in steps 1, 2, and 3, as shown in inset drawing #1 on Pictorial 4-2. Then disregard steps 4, 5, and 6.
2. If you intend to use a Heathkit Model HD-10 Keyer, disregard steps 1, 2, and 3. Then wire jack BB as directed in steps 4, 5, and 6, and as shown in inset drawing #2 on Pictorial 4-2.
3. You can use a "straight" key with both wiring options.
  - ( ) 1. 3-1/2" yellow wire from hole W (S-1) to jack BB lug 2 (NS).
  - ( ) 2. 7" yellow wire from hole AA (S-1) to jack BB lug 2 (S-2).
  - ( ) 3. 4" yellow wire from hole Y (S-1) to jack BB lug 1 (S-1).

- OR -

  - ( ) 4. 3-1/2" yellow wire from hole W (S-1) to jack BB lug 1 (NS).
  - ( ) 5. 7" yellow wire from hole AA (S-1) to jack BB lug 1 (S-2).
  - ( ) 6. 4" yellow wire from hole Y (S-1) to jack BB lug 2 (S-1).
- ( ) Refer to the inset drawing on Pictorial 4-2 and install a female connector pin (#432-73) on one end of a 4" yellow wire.
- ( ) Insert the connector pin into chassis connector BC hole 3. Push in on the pin until it locks in place in the chassis connector.
- ( ) Connect the free end of the 4" yellow wire to circuit board hole Z (S-1).
- ( ) Connect a 3-1/2" yellow wire from circuit board hole BB (S-1) to jack BD lug 2 (NS).
- ( ) Connect a 2" yellow wire from hole DD (S-1) to jack BD lug 1 (NS).

## MOUNTING PANEL/CIRCUIT BOARD ASSEMBLY

Refer to Pictorial 4-3 in the Illustration Booklet for the following steps.

- ( ) Refer to inset #1 on the Pictorial and press plastic chassis nuts into both holes at CA in the right side of the chassis.
- ( ) In the same manner, press plastic chassis nuts into both holes at DA in the other side of the chassis.
- ( ) Install 6-32 x 3/8" hardware into chassis holes AB and AD in the front of the chassis.

**CAUTION:** When you perform the following steps, be sure you position the front edge of the circuit board ABOVE the flange on the front of the chassis as shown in the inset drawing on the Pictorial.

- ( ) Spring the chassis sides outward slightly; then install the panel/circuit board assembly inside the chassis. Be careful you do not pinch any wires when you insert the knobs of the pushbutton switch assembly through the opening in the front of the chassis.
- ( ) Check the operation of each pushbutton switch. Reposition any wires that interfere with proper operation.
- ( ) Be sure the front edge of the circuit board is above the chassis flange; then loosely secure the rear panel to the chassis with #6 x 1/4" sheet metal screws at the four indicated locations.
- ( ) Carefully push the cables and wires away from the front of the chassis so the mounting holes in the front edge of the circuit board are exposed.
- ( ) Secure the front edge of the circuit board to the flange with 6-32 x 1/4" hardware. Then tighten the four screws in the rear panel.

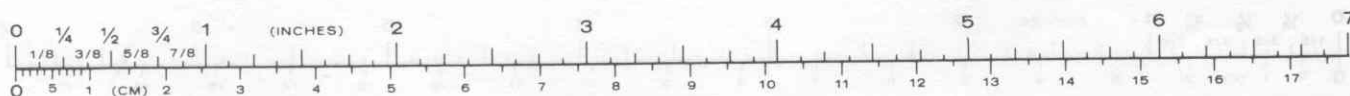

## CHASSIS PARTS MOUNTING AND WIRING

Refer to Pictorial 4-4 in the Illustration Booklet for the following steps.

- ( ) R301, R302, SW301: Refer to Detail 4-4A and install a control-with-switch (#14-17) at AF. Position the control as shown in the Pictorial.

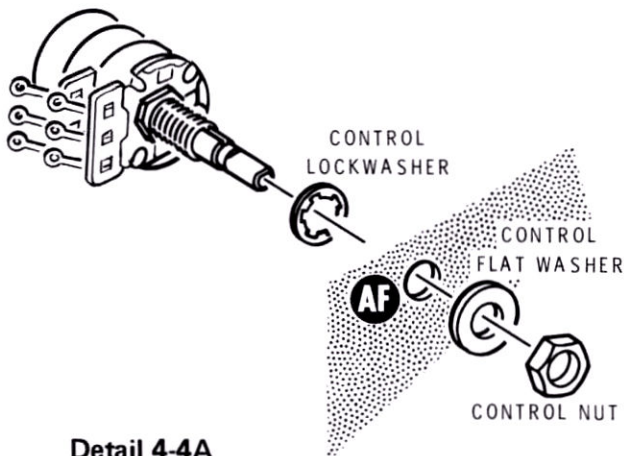

**Detail 4-4A**

NOTE: Inset drawing #1 on Pictorial 4-4 is a "blow-up" of the wiring of control AF. Refer to both inset drawing #1 and Pictorial 4-4 when you perform the following ten steps.

Connect the black, green, and white wires of the cable marked X on the Pictorial to control AF as follows:

1. ( ) White to lug 6 (S-1).
2. ( ) Green to lug 5 (S-1).
3. ( ) Black to lug 4 (NS).

NOTE: Protruding from cable-tie F are the free ends of two shielded cables. Connect these cables as directed in the following steps.

4. ( ) At the free end of the shielded cable coming from cable-tie F and switch SW4, connect the inner lead to control AF lug 2 (S-1) and the shield lead to lug 1 (NS).
5. ( ) At the free end of the other shielded cable coming from cable-tie F, connect the inner lead to control AF lug 3 (S-1) and the shield lead to lug 1 (NS).

6. ( ) Remove all of the insulation from a 2" length of yellow wire.
7. ( ) Insert one end of this bare wire through control AF lug 1 (NS); then on to lug 4 (NS).

NOTE: When a wire passes through a connection and goes to another point, as in the preceding step, it will count as two wires in the solder instruction, one entering and one leaving the connection. When you solder this type connection, be sure you use enough solder and heat to properly solder the "through wire" and all other wires at the connection.

8. ( ) Solder all of the wires at control AF lug 1 (S-4). Position the free end of the wire out of the way for connection later.
  9. ( ) Cut both leads of a .47  $\mu$ F Mylar capacitor to 3/4".
  10. ( ) C305: Connect the prepared .47  $\mu$ F capacitor between control AF lugs 4 (S-3) and 8 (NS).
- ( ) Refer to inset drawing #2 on the Pictorial and install a female connector pin (#432-73) on one end of an 8-1/2" yellow wire.
- ( ) Insert the connector pin into chassis connector BC hole 6. Push in on the pin until it locks in place in the connector.
- ( ) Connect the other end of the wire to control AF lug 7 (S-1).
- ( ) Connect a 6" yellow wire from circuit board hole E to control AF lug 8 (S-2).
- ( ) Refer to Detail 4-4B and connect a 1-1/2" yellow wire to lug 3 (S-1) of the loading capacitor (#26-154) as shown.

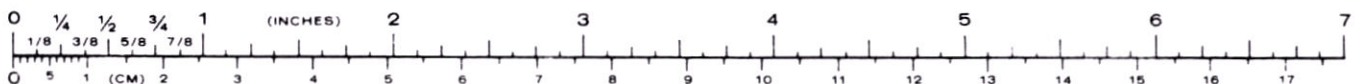

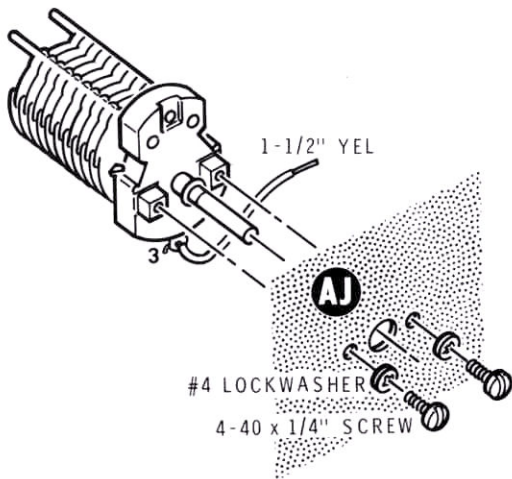

**Detail 4-4B**

- ( ) C303: Refer to Detail 4-4B and install the prepared loading capacitor at AJ with 4-40 x 1/4" hardware. Position the capacitor as shown in the Pictorial. Also, be sure no wires or cables are caught under the capacitor.
- ( ) Connect the free end of the 1-1/2" yellow wire coming from lug 3 of this capacitor to switch SW2 pin 11 (S-1). NOTE: Be sure you position this wire so that, when the movable plates of the capacitor are turned, they will not hit the wire.
- ( ) Locate the shielded cable coming from cable-tie E. Then cut the shield lead off the free end of the cable.
- ( ) Connect the inner lead of this cable to capacitor AJ lug 2 (S-1).

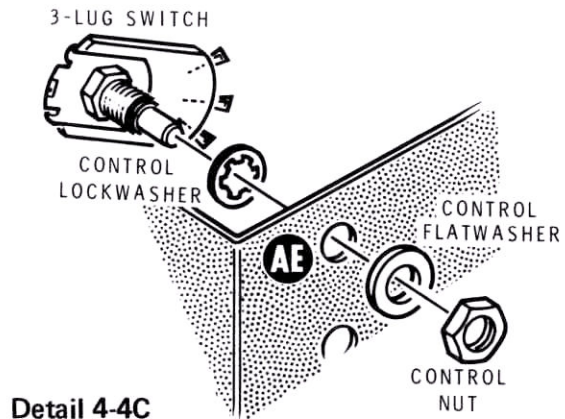

**Detail 4-4C**

- ( ) SW302: Refer to Detail 4-4C and install a 3-lug rotary switch (#63-3) at AE. Position the switch so the space between lugs 1 and 2 is toward the screw at AD, as shown in the Pictorial.

Connect the 3-wire cable coming from cable-tie F (cable marked Y on the Pictorial) to switch AE as follows:

- ( ) Red to lug 3 (S-1).
- ( ) White to lug 2 (S-1).
- ( ) Black to lug 1 (S-1).
- ( ) Carefully press the wires down out of the way under the body of the switch.
- ( ) Refer to Detail 4-4D and mount the vernier drive (#100-1608) at AH with 4-40 x 1/2" hardware and 3/16" spacers. Be sure to center the vernier drive in the opening.

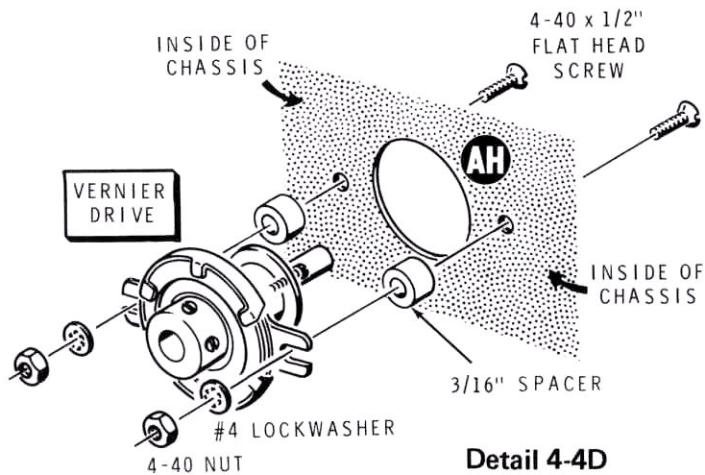

**Detail 4-4D**

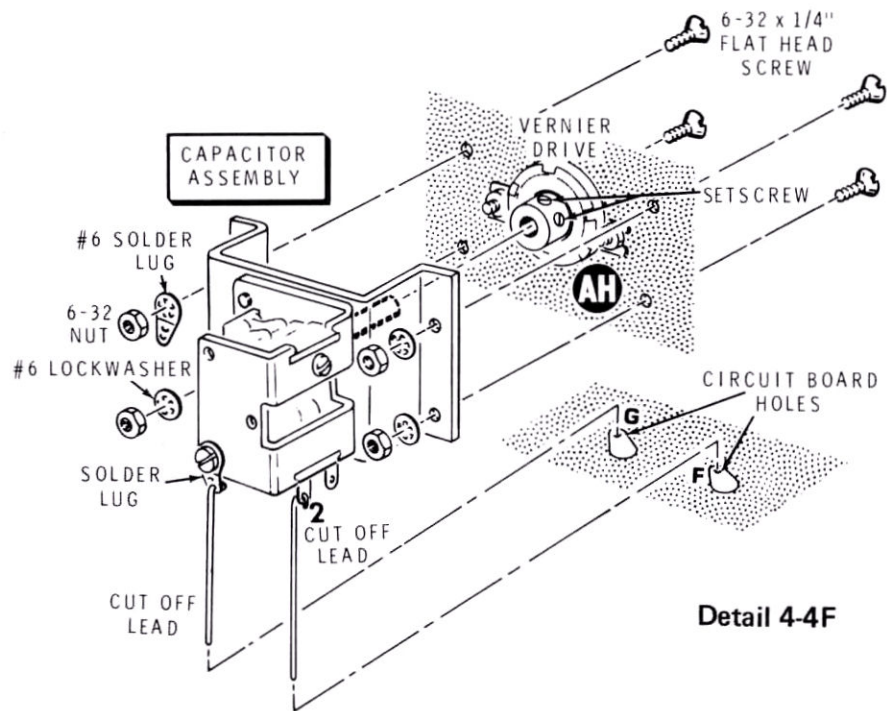

**CAUTION:** Keep the rotor (movable plates) of the capacitor closed while you perform the following steps.

- ( ) C302A/B: Refer to Detail 4-4E and mount the VFO tuning capacitor (#26-152) on the capacitor mounting bracket with 6-32 x 3/16" hardware. **CAUTION:** Be sure you position the bracket so its wide space is located as shown.
- ( ) Slowly turn the shaft of the VFO tuning capacitor to make sure the rotor plates clear the three mounting screws. If the plates do not clear all three screws, make sure you used 6-32 x 3/16" screws for mounting (not the 6-32 x 1/4" screws).
- ( ) Mount a #6 solder lug on the capacitor frame with a 6-32 x 1/8" round head screw. Position the solder lug as shown in the Detail.
- ( ) Remove the insulation from two 1-1/2" yellow wires.
- ( ) Refer to Detail 4-4F and connect a 1-1/2" bare wire to the solder lug on the capacitor assembly as shown (S-1).
- ( ) In a similar manner, connect a 1-1/2" bare wire to lug 2 on the capacitor (S-1).

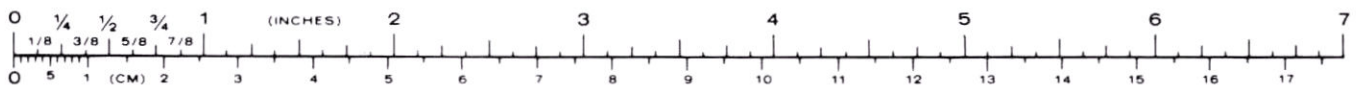
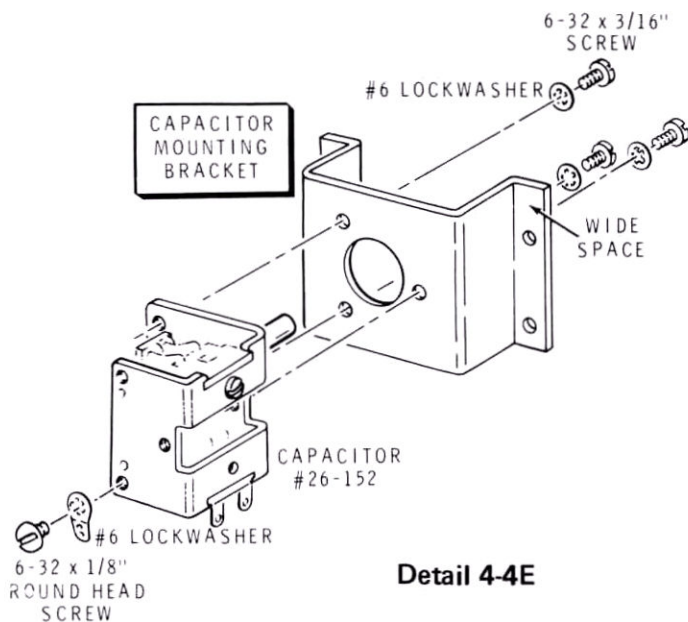

## NOTES:

1. You will guide the bare wires on the capacitor assembly into holes in the circuit board when you mount the assembly in the following steps. At the same time, you will insert the shaft of the capacitor into the hole in the vernier drive.
  2. Loosen the setscrews in the vernier drive just enough to allow the capacitor shaft to enter the hole in the drive. **CAUTION:** Be sure you do not lose the setscrews.
- ( ) Guide the two bare wires on the capacitor assembly into circuit board holes G and F, at the same time, insert the capacitor shaft into the hole in the vernier drive. See Pictorial 4-4 and Detail 4-4F.
- ( ) Refer to Detail 4-4F and mount the capacitor assembly at AA with 6-32 x 1/4" flat head hardware. **NOTE:** Use a #6 solder lug at AG instead of a lockwasher. Also, be sure none of the cables are pinched under the assembly.

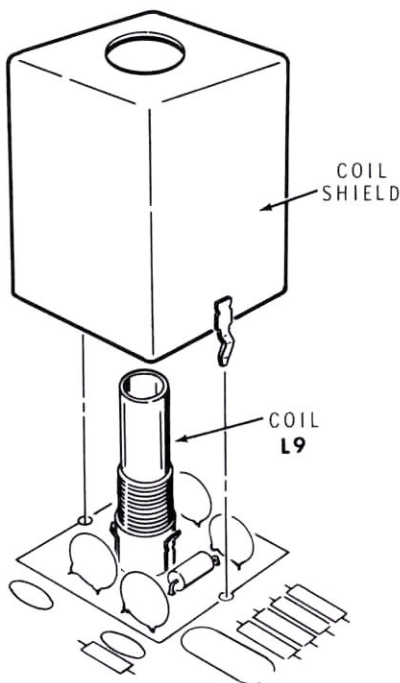

Detail 4-4G

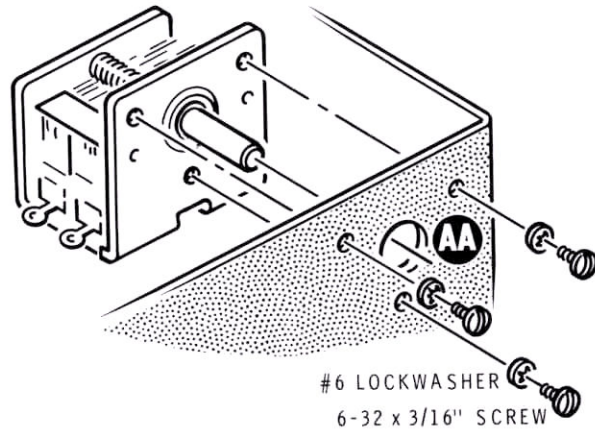

Detail 4-4H

- ( ) Connect the free end of the bare wire coming from control AF lug 1 to solder lug AG (S-1).
- ( ) Locate the coil shield (#206-502). Then refer to Detail 4-4G and install the shield over coil L9 on the circuit board.

**NOTE:** Before you solder the wires in the next step, be sure you pull them as far as possible through the circuit board holes.

- ( ) Turn the Transceiver over and solder the shield lugs and the two bare wires protruding from the circuit board to the foil. Then cut off ONLY the excess wire lengths.
- ( ) C301A/B: Refer to Detail 4-4H and install a 2-section variable capacitor (#26-151) at AA with 6-32 x 3/16" hardware.
- ( ) Connect a 2-1/2" yellow wire from coil L1 lug 4 (S-1) to capacitor AA lug 1 (S-1).
- ( ) Connect a 3" yellow wire from circuit board hole A (S-1) to capacitor AA lug 2 (S-1).

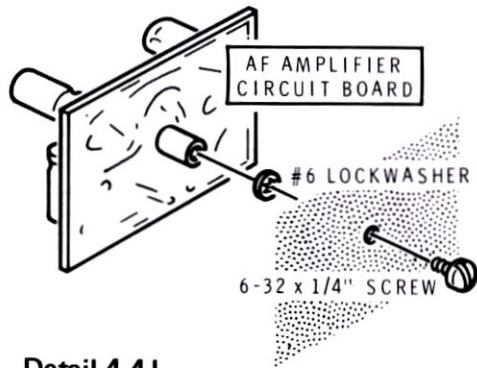

Detail 4-4J

NOTE: In the next step, you will connect the free end of "the green wire," at the lower left corner of the chassis, to the circuit board of the previously set-aside AF amplifier assembly.

- ( ) Connect the free end of the green wire (coming from 3-wire cable X) to the hole marked IN on the AF amplifier circuit board (S-1).
- ( ) Refer to Detail 4-4J and mount the AF amplifier assembly at CB with 6-32 x 1/4" hardware. Position the assembly as shown in the Pictorial.

Refer to Pictorial 4-4 for the following steps.

Connect the free end of the wires coming from the AF amplifier assembly as follows:

- ( ) Wire from hole +12 to main circuit board hole VA (S-1).
- ( ) Wire from hole GND to jack BD lug 1 (S-2).
- ( ) Wire from hole OUT to jack BD lug 2 (S-2).

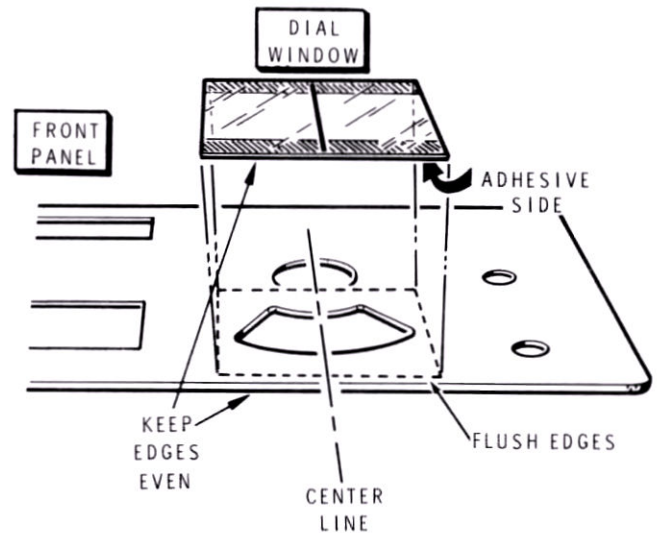

Detail 4-5A

## FRONT PANEL MOUNTING

- ( ) Refer to Detail 4-5A and mark the inside of the front panel as shown by the center line through hole AH.
- ( ) Remove the lengths of tape from the dial window (#446-602-1). Position the black line on the window over the line marked on the panel. Position the edge of the window even with the edge of the panel as shown. Then press the window firmly onto the panel. NOTE: Be careful you do not scratch the window.

Refer to Pictorial 4-5 in the Illustration Booklet for the following steps.

- ( ) Refer to Detail 4-5B and turn the shaft of vernier drive AH until its setscrews are positioned as shown.



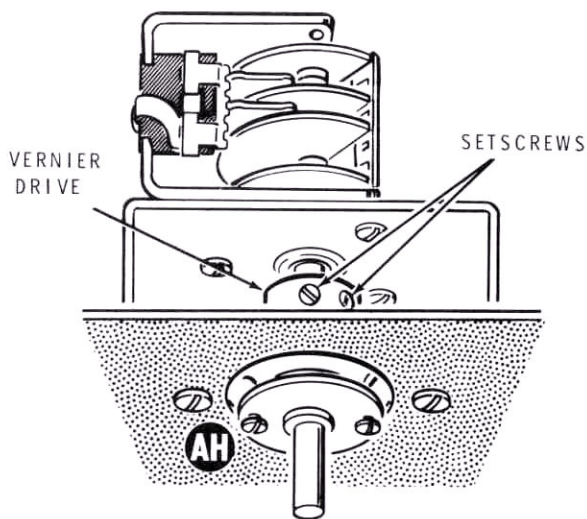

Detail 4-5B

- ( ) Temporarily remove the two brass screws from the front of the vernier drive.
- ( ) Place the dial on the vernier drive so the scale of the dial is toward the right as shown in the Pictorial. Then secure the dial to the vernier drive with the previously removed brass screws. **CAUTION:** Do not scratch the face of the dial.
- ( ) Place the front panel on the chassis. Then secure it with control nuts at AE and AF. Be careful you do not scratch the panel when you tighten the control nuts.

## INSTALLING KNOBS

- ( ) Start 6-32 x 1/8" setscrews in the four small knobs.
- ( ) Start an 8-32 x 3/8" setscrew into the large knob.
- ( ) Turn the outer and inner shafts of control AF counterclockwise as far as they will go. **NOTE:** Be sure you turn the inner shaft until the switch clicks off.
- ( ) With the tab of the silver knob in the MIN position, press the knob onto the slotted outer shaft of control AF.

- ( ) Place the split bushing on the inner shaft of control AF; then press a small knob on the bushing. Turn the knob until its color dot is lined up with the word OFF on the panel and securely tighten the knob setscrew.
- ( ) Turn the shaft of capacitor AA fully counterclockwise and place a small knob on its shaft. Line up the color dot on the knob with the left scale-mark on the panel; then tighten the setscrew.
- ( ) Turn the shaft of switch AE fully clockwise and place a small knob on its shaft. Line up the color dot with the NARROW line on the panel and tighten the setscrew.
- ( ) Turn the shaft of capacitor AJ until the capacitor plates are fully meshed; then place a small knob on the shaft. Line up the color dot on the knob with the left scale-mark on the panel and tighten the setscrew.
- ( ) Place the large knob on the shaft of vernier drive AH and tighten the setscrew. **NOTE:** Be sure the knob turns freely and does not rub against the panel.

**NOTE:** When you perform the next step, be very careful you do not bend the plates of the capacitor.

- ( ) Carefully turn the rotor (movable plates) of the capacitor at AH fully clockwise (unmeshed).
- ( ) Turn the large knob **CLOCKWISE** until the mark to the left of the zero on the dial scale is lined up with the black line of the window.
- ( ) Refer to Detail 4-5B and securely tighten the two setscrews in the vernier drive.

**NOTE:** Do not forcefully rotate the tuning capacitor to its extreme end stops. This could damage the tuning capacitor plates.

- ( ) Rotate the large knob and turn capacitor AH to its full open or closed position; then continue to turn the large knob. The left or right end of the dial scale should stay lined up with the reference line of the window. **NOTE:** If the dial does not stay lined up, the capacitor shaft is slipping in the vernier drive. If this occurs, perform the previous two steps over again and make sure the set screws in the vernier drive are tight.

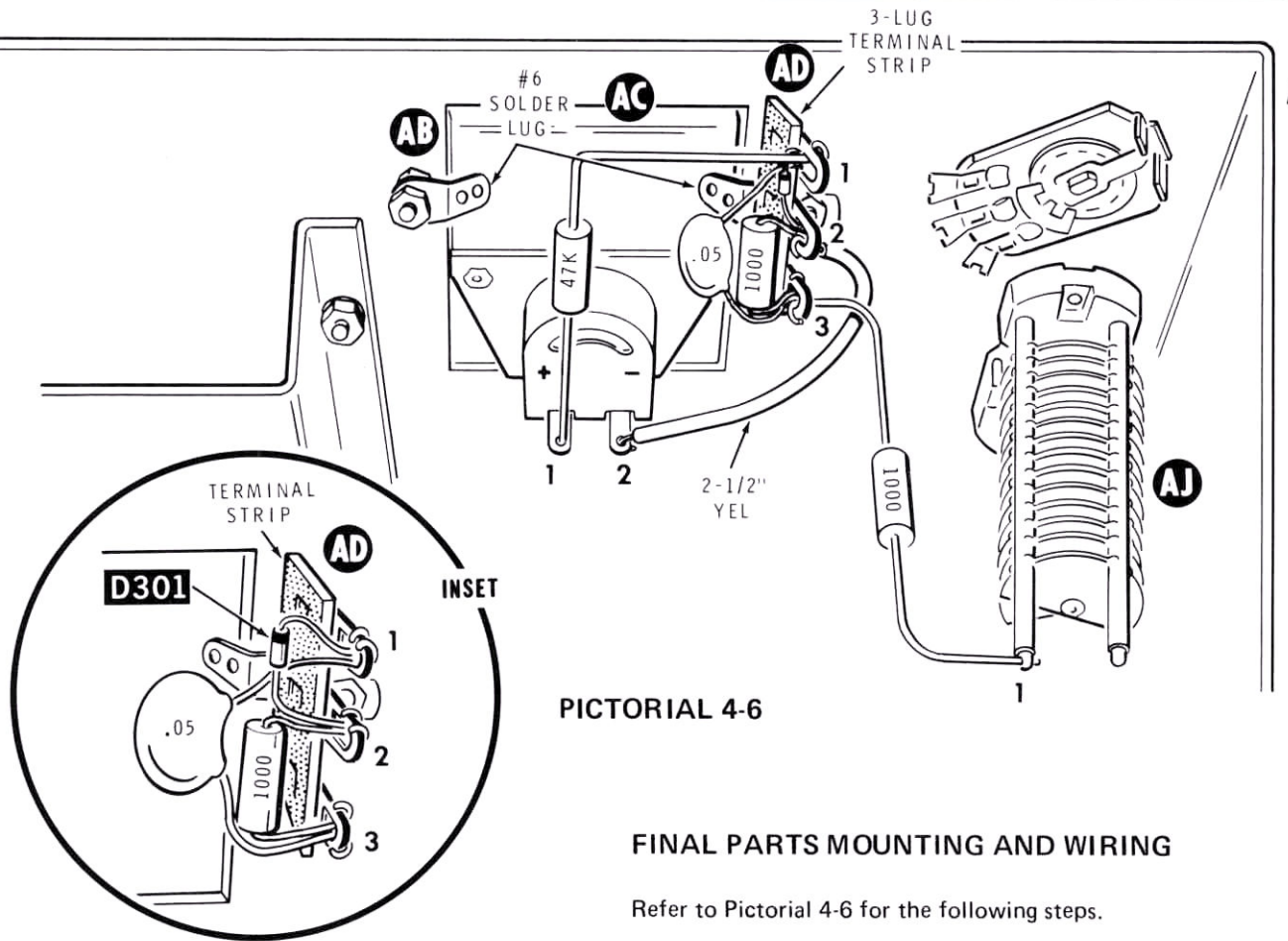

**FINAL PARTS MOUNTING AND WIRING**

Refer to Pictorial 4-6 for the following steps.

- ( ) Refer to Detail 4-6A and install the signal meter at AC. Use a #6 solder lug and 6-32 nut at AB. Use a #6 solder lug, 3-lug terminal strip, #6 lockwasher, and 6-32 nut at AD. NOTE: Be sure you position the terminal strip and solder lugs as shown in the Pictorial.
- ( ) R304. Connect a 1000 Ω (brown-black-red) resistor from capacitor AJ lug 1 (S-1) to terminal strip AD lug 3 (NS).
- ( ) Remove the shorting wire or clip between lugs 1 and 2 of meter AC.
- ( ) R305: Connect a 47 kΩ (yellow-violet-orange) resistor between meter AC lug 1 (S-1) and terminal strip AD lug 1 (NS).
- ( ) Connect a 2-1/2" yellow wire from meter AC lug 2 (S-1) to terminal strip AD lug 2 (NS).

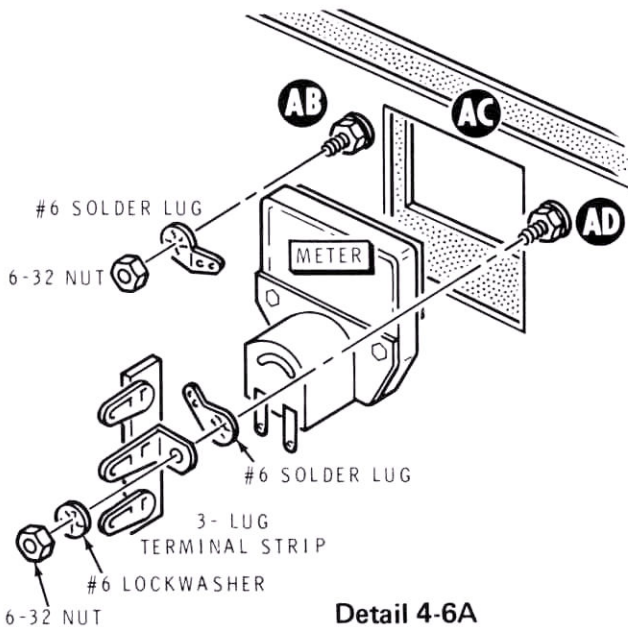

NOTE: Refer to the inset drawing on Pictorial 4-6 for the following steps.

- ( ) R303: Connect a 1000  $\Omega$  (brown-black-red) resistor between terminal strip AD lugs 3 (NS) and 2 (NS).
- ( ) D301: Connect the lead at the banded end of a 1N458 diode (#56-24) to terminal strip AD lug 1 (NS). Connect the other diode lead to lug 2 (S-3).
- ( ) C304: Connect a .05  $\mu\text{F}$  disc capacitor between terminal strip AD lugs 3 (S-3) and 1 (S-3).

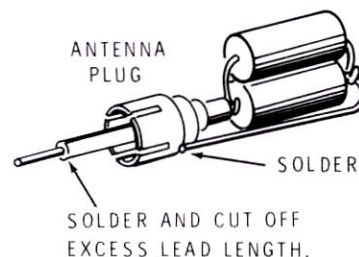
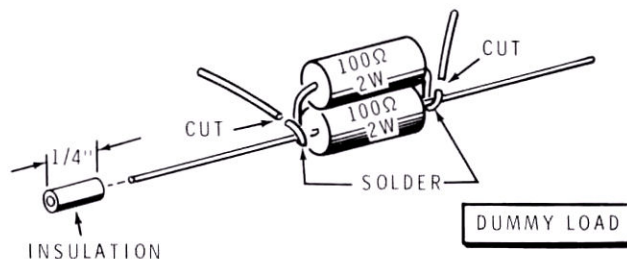

PICTORIAL 5-2

### PREPARING DUMMY LOAD

Refer to Pictorial 5-2 for the following steps.

- ( ) Locate the two 100  $\Omega$ , 2-watt (brown-black-brown) resistors. Bend the leads of one resistor around the leads of the other resistor as shown. Then solder both connections and cut off the indicated resistor leads.
- ( ) Place the previously saved 1/4" length of insulation on one lead of the resistor assembly.
- ( ) Insert this lead of the assembly into the antenna plug as shown. Then solder the lead to the pin. NOTE: Apply heat to the tip of the pin only long enough to allow the solder to flow into the pin. Allow the connection to cool; then cut off the excess lead length.
- ( ) Bend the other lead as shown. Then solder the lead to the shell of the antenna plug.

This completes the wiring of your Transceiver. Carefully inspect all connections for loose wires or unsoldered connections. Remove any wire clippings or solder splashes.

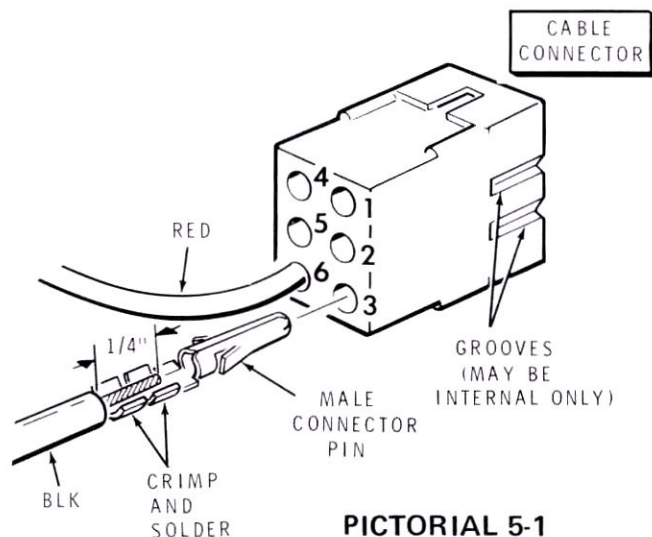

PICTORIAL 5-1

### PREPARING POWER CABLE

Refer to Pictorial 5-1 for the following steps.

- ( ) Remove 1/4" of insulation from each end of the red and the black wires supplied with the kit. Then twist the strands and apply a small amount of solder to the wire ends to hold the strands together. NOTE: Save one of the 1/4" lengths of insulation for use later.
- ( ) Install a male connector pin on one end of the red and one end of the black wires.
- ( ) Insert the connector pin on the black wire into hole 3 of the cable connector. Press the pin in until it locks in place in the cable connector.
- ( ) In the same manner, insert the connector pin on the red wire into hole 6 of the cable connector.



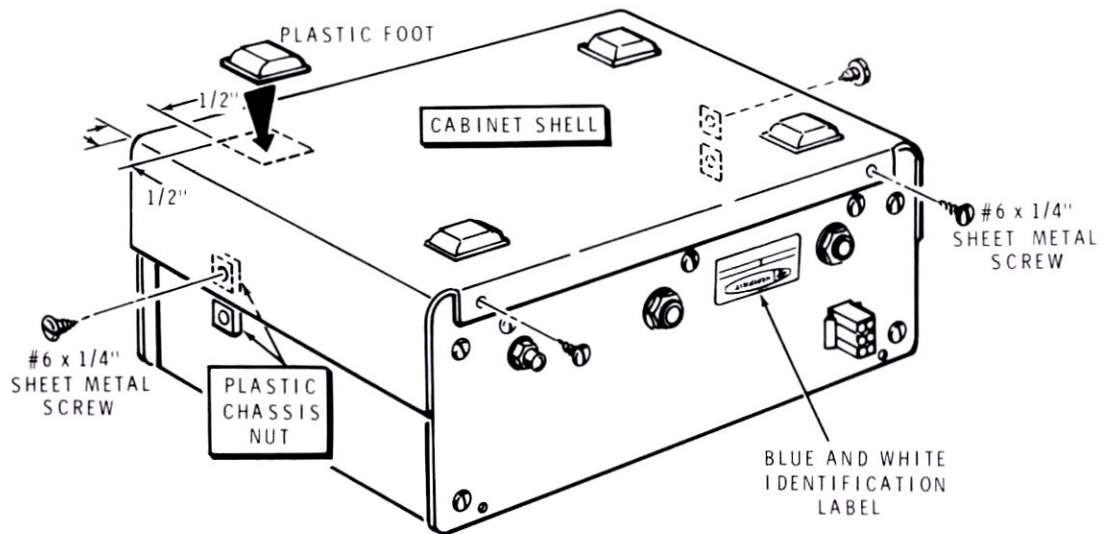

PICTORIAL 5-3

Refer to Pictorial 5-3 for the following steps.

- ( ) Place a cabinet shell on the bottom of the Transceiver. Secure the shell with four #6 x 1/4" sheet metal screws at the rear and sides of the Transceiver.
- ( ) Remove the protective backing from a plastic foot. Then press the foot onto the corner of the bottom cabinet shell as shown.
- ( ) In a similar manner, install a plastic foot at each remaining corner.

NOTE: The blue and white identification label you will install in the next step shows the model number and production series number of your kit. Refer to these numbers in any communications you may have with the Heath Company regarding your kit. This will assure you of receiving the most up-to-date information in return.

- ( ) Carefully remove the backing paper from the blue and white label. Then press the label on the rear panel at the indicated location. Place the backing paper over the label and then firmly press the label on the panel.

Proceed to the "Initial Tests."

# INITIAL TESTS

The following tests are performed on your Transceiver to make sure it is operating properly before you begin alignment. If you do not obtain the indicated results at any time, turn the Transceiver off and refer to the "In Case of Difficulty" section on Page 69.

You will need a pair of high impedance (about 2000  $\Omega$ ) headphones, a key, and a 13.4-volt DC power supply to complete the Initial Tests and Alignment.

Refer to Figure 1-2 in the Illustration Booklet for the following steps.

- ( ) Set all of the front panel controls fully counterclockwise.
- ( ) Set the SIDETONE LEVEL control to the center of its rotation.
- ( ) Push the 7.0 MHz band switch in.
- ( ) Connect the 50  $\Omega$  dummy load to the ANTENNA socket on the rear panel.
- ( ) Connect a pair of headphones to the HEADPHONE jack on the rear panel.
- ( ) Connect the key to the KEY jack on the rear panel.
- ( ) Plug the power cable onto the POWER socket on the rear panel.
- ( ) Connect the power cable red lead to the + (positive) terminal and the black lead to the - (negative) terminal of a 13.4 VDC power source. CAUTION: Be sure you observe the correct polarity; otherwise the transistors in the Transceiver will be damaged.
- ( ) Turn the Transceiver power on by rotating the AF GAIN control clockwise until it "clicks" on.
- ( ) Turn the AF GAIN control to the center of its rotation. Noise should be heard in the headphones.
- ( ) Key the Transceiver. The relay should click and a sidetone should be heard in the headphones. Adjust the SIDETONE VOLUME control on the circuit board for a comfortable listening level. Release the key.
- ( ) Turn the AF GAIN control counterclockwise until it "clicks" off.

This completes the Initial Tests. Proceed to the "Alignment" section. Do not disconnect the power supply, key, or headphones from the Transceiver.

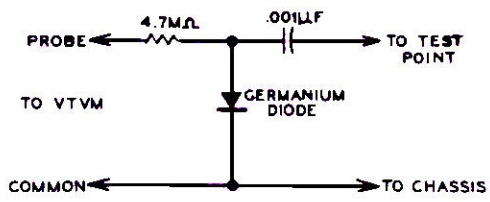

Figure 1-3

# ALIGNMENT

The following alignment procedure requires the use of a calibrated Receiver capable of receiving 7.0 to 7.25 MHz, an RF Signal Generator, and a VTVM with an RF Probe. If a Signal Generator is not available, use an on-the-air signal. Figure 1-3 is a schematic of a simple RF Probe which you can make if one is not available. CAUTION: A cabinet shell must be installed on the bottom of the Transceiver before you start the following procedure.

Refer to Figure 1-2 in the Illustration Booklet for the following procedures.

## HFO (Heterodyne Frequency Oscillator)

- ( ) Connect the RF probe of the VTVM to test point TP1. This is the lead at the indicated end of resistor R94, a 68 k $\Omega$  (blue-gray-orange) resistor.
- ( ) Turn the Transceiver on and press the 3.5 MHz pushbutton.

NOTE: You can reach the bottom slug in coils L17/L18 and L19/L21 by inserting the longer end of the alignment tool through the top slug; then on down to the bottom slug. Be careful when you do this so that you do not damage or turn the top slug.

- ( ) Use the smaller alignment tool and adjust the bottom slug in coil L17/L18 to obtain a peak reading on the VTVM. Then turn the slug an additional 1/4 turn clockwise. The VTVM should read approximately 0.3 volts.
- ( ) Press the 7.0 MHz pushbutton.
- ( ) Adjust the top slug in coil L17/L18 to obtain a peak reading on the VTVM. Then turn the slug an additional 1/4 turn counterclockwise. The meter should read approximately 0.3 volts.
- ( ) Press the 14.0 MHz pushbutton.
- ( ) Adjust the bottom slug in coil L19/L21 to obtain a peak reading on the VTVM. Then turn the slug an additional 1/4 turn clockwise. The VTVM should read approximately 0.2 volts.
- ( ) Press the 21.0 MHz pushbutton.
- ( ) Adjust the top slug in coil L19/L21 to obtain a peak reading on the VTVM. The VTVM should read approximately 0.2 volts. Then turn the slug 1/4 turn counterclockwise.
- ( ) Disconnect the VTVM from the Transceiver.

## VFO (Variable Frequency Oscillator)

- ( ) Turn the calibrated receiver on and allow it to warm up. Tune the receiver to approximately 7.0 MHz.
- ( ) Press the 7.0 MHz pushbutton on the Transceiver.
- ( ) Connect one end of a suitable length of wire to the antenna terminal on the calibrated receiver. Loop the other end of this wire around coil L19/L21 as shown in inset drawing #2 on Figure 1-2.
- ( ) Turn the Transceiver on and allow it to warm up for at least 30 minutes before you proceed with the following adjustments.

NOTE: In the following steps, you will zero beat the calibrated receiver; first against its own crystal calibrator, and then against the Transceiver. A zero beat is a point where the two frequencies being combined (or beat against each other) are exactly the same. As you approach zero beat, the tone caused by the two combined frequencies will gradually decrease in pitch and volume until it stops. This point is very sharp so you must tune very carefully.

- ( ) Set the calibrated receiver's Function switch to the SSB or CW position.
- ( ) Tune the calibrated receiver to 7.0 MHz. Then turn on its crystal calibrator and zero beat the receiver frequency against the crystal calibrator frequency.
- ( ) Turn off the crystal calibrator. NOTE: Be careful that you do not change the setting of the receiver frequency.
- ( ) Refer to inset drawing #1 of Figure 1-2 and insert the metal blade (#205-778) into the small end of the plastic nut starter.

NOTE: Use the alignment tool that you made from the nut starter and blade for all trimmer adjustments. DO NOT use a screwdriver.

- ( ) Turn the Transceiver tuning dial to 0.
- ( ) Adjust trimmer capacitor C302B until you hear a zero beat from the calibrated receiver.

- ( ) Turn the Transceiver dial to 250.
- ( ) Turn the calibrated receiver dial to 7.250 MHz.
- ( ) Use the larger alignment tool to turn the slug in coil L9 until you hear a zero beat from the calibrated receiver. It may be necessary to turn down the calibrated receiver's AF gain control.
- ( ) *Repeat the VFO alignment steps several times until the calibrated receiver's dial coincides with the 0 and 250 marks on the Transceiver's dial.*
- ( ) Turn off the calibrated receiver and remove the wire from around coil L19/L21 in the Transceiver. The calibrated receiver will no longer be used.

## MIXER AMPLIFIER

- ( ) Turn the Transceiver tuning dial to 100.
- ( ) Connect the RF Probe of the VTVM to test point TP2. This is the lead at the indicated end of R49, a 270  $\Omega$  (red-violet-brown) resistor.
- ( ) Press the 3.5 MHz pushbutton and adjust coil L13 for a peak reading on the VTVM.
- ( ) Press the 7.0 MHz pushbutton and adjust coil L14 for a peak reading on the VTVM.
- ( ) Press the 14.0 MHz pushbutton and adjust coil L15 for a peak reading on the VTVM.
- ( ) Turn the Transceiver tuning dial to 150.

NOTE: When you perform the next step, you may have to turn the coil slug several turns counterclockwise before you obtain a peak reading on the VTVM.

- ( ) Press the 21.0 MHz pushbutton and adjust coil L16 for a peak reading on the VTVM.
- ( ) Disconnect the RF Probe from Test point TP2.



## TRANSMITTER

( ) Plug the previously prepared 50  $\Omega$  dummy load into the ANTENNA socket on the back of the Transceiver. (This may already be connected to the Transceiver.)

( ) Connect the key to the KEY jack on the back of the Transceiver. (This also may already be connected to the Transceiver.)

NOTE: Use the alignment tool that you made from the nut starter and blade for all trimmer adjustments. DO NOT use a screwdriver.

( ) Turn the screws in trimmers C95, C99, C103, and C106 clockwise until they stop turning. Do not force the screws.

( ) Turn the screw in trimmer C95 1/2 turn counterclockwise.

( ) Turn the screw in trimmer C99 1/8 turn counterclockwise.

( ) Turn the screw in trimmer C103 1 turn counterclockwise.

( ) Turn the screw in trimmer C106 1/4 turn counterclockwise.

( ) Make sure the TUNING dial is set to 100.

( ) Press the 3.5 MHz pushbutton.

( ) Set the LOADING control on the front panel to the 12 o'clock position.

NOTE: In the following steps, the adjustments will be quite broad.

( ) Key the Transceiver and adjust trimmer C95 for a maximum reading on the RELATIVE POWER meter.

( ) Key the Transceiver and adjust the LOADING control on the front panel to obtain a maximum reading on the RELATIVE POWER meter.

( ) Repeat the previous two steps.

( ) Press the 7.0 MHz pushbutton.

( ) Set the LOADING control to the 12 o'clock position.

( ) Key the Transceiver and adjust trimmer C99 to obtain a maximum reading on the RELATIVE POWER meter.

( ) Key the Transceiver and adjust the LOADING control on the front panel to obtain a maximum reading on the RELATIVE POWER meter.

( ) Repeat the previous two steps.

( ) Press the 14.0 MHz pushbutton.

( ) Set the LOADING control to the 12 o'clock position.

( ) Key the Transceiver and adjust trimmer C103 to obtain a maximum reading on the RELATIVE POWER meter.

( ) Key the Transceiver and adjust the LOADING control on the front panel to obtain a maximum reading on the RELATIVE POWER meter.

( ) Repeat the previous two steps.

( ) Press the 21.0 MHz pushbutton.

( ) Set the LOADING control to the 12:00 o'clock position.

( ) Key the Transceiver and adjust trimmer C106 to obtain a maximum reading on the RELATIVE POWER meter.

( ) Key the Transceiver and adjust the LOADING control to obtain a maximum reading on the RELATIVE POWER meter.

( ) Repeat the previous two steps.

( ) Turn the Transceiver off.

( ) Disconnect the key and dummy load from the Transceiver.

## RECEIVER

- ( ) Connect a pair of headphones to the HEADPHONES jack on the back of the Transceiver.

NOTE: You may use a nearby accurately calibrated transmitter for the following adjustments. If you do use one, connect a small piece of wire to the Transceiver's antenna socket. The small wire will act as a simple antenna. (You may also use an appropriate antenna.)

- ( ) Connect a signal generator to the ANTENNA socket on the back of the Transceiver.
- ( ) Turn the signal generator on and allow it to warm up.
- ( ) Set the Transceiver tuning dial to 250.
- ( ) Set the RECEIVER PRESELECTOR to 14.
- ( ) Set the RF GAIN control to MAX.
- ( ) Turn the Transceiver on and adjust the AF GAIN control for a comfortable listening level.

NOTE: In the following steps, as you approach the point of resonance of a trimmer capacitor or coil, the sound from the headphones will increase. As this occurs, decrease the output of the signal generator to the lowest level that you can still hear. This will prevent overloading the receiver.

- ( ) Press the 3.5 MHz pushbutton.
- ( ) Adjust the signal generator frequency to approximately 3.750 MHz or until you hear the signal in the headphones. The output of the generator may have to be quite high.
- ( ) Alternately adjust trimmers C3 and C16 for maximum sound in the headphones.
- ( ) Press the 7.0 MHz pushbutton.

- ( ) Adjust the signal generator frequency to approximately 7.25 MHz or until you hear it in the headphones. The output of the generator may have to be quite high.
- ( ) Alternately adjust trimmers C6 and C19 for maximum sound in the headphones.
- ( ) Set the Transceiver tuning dial to 100.
- ( ) Adjust the signal generator frequency to approximately 7.100 MHz or until you hear it in the headphones.
- ( ) Adjust the RECEIVER PRESELECTOR for maximum sound in the headphones.
- ( ) Readjust trimmer C6 for maximum sound in the headphones. NOTE: Do not adjust trimmer C19.
- ( ) Press the 14.0 MHz pushbutton.
- ( ) Set the Transceiver tuning dial to 250.
- ( ) Set the RECEIVER PRESELECTOR to 14.
- ( ) Adjust the signal generator frequency to approximately 14.25 MHz or until you hear it in the headphones.
- ( ) Alternately adjust trimmers C7 and C22 for maximum sound in the headphones.
- ( ) Press the 21.0 MHz pushbutton.
- ( ) Adjust the signal generator frequency to approximately 21.25 MHz or until you hear it in the headphones.
- ( ) Alternately adjust trimmers C9 and C24 for maximum sound in the headphones.
- ( ) Turn the Transceiver off.
- ( ) Disconnect the signal generator from the Transceiver.

This completes the "Transceiver Alignment," Proceed to "Final Assembly."

# FINAL ASSEMBLY

Refer to Pictorial 5-4 for the following steps.

- ( ) Place the remaining cabinet shell on the Transceiver as shown.
- ( ) Secure the cabinet shell to the Transceiver with #6 x 1/4" sheet metal screws at the rear and sides as shown.

This completes the assembly of your Transceiver. Proceed to "Operation."

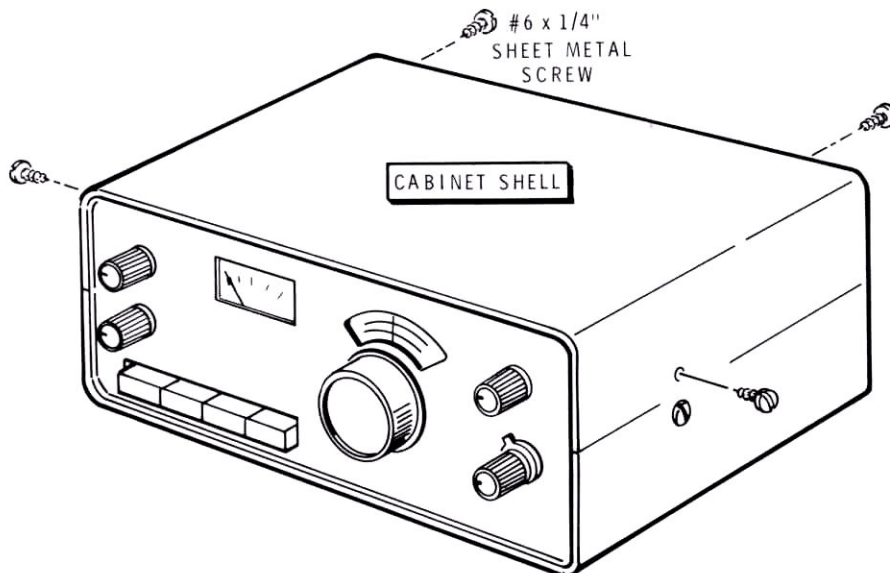

PICTORIAL 5-4



# OPERATION

Refer to Figure 1-2 for the following steps.

- ( ) Plug the power cable onto the POWER socket on the rear panel.
- ( ) Connect the power cable red lead to the + (positive) terminal and the black lead to the – (negative) terminal of a 13.4 VDC power source. CAUTION: Be sure you observe the correct polarity; otherwise the transistors in the Transceiver will be damaged.
- ( ) Connect a key to the KEY jack on the rear panel.
- ( ) Connect an antenna to the ANTENNA socket on the rear panel. (See the following information on antennas.)
- ( ) Connect a pair of headphones to the HEADPHONES jack on the rear panel.

## ANTENNAS

The Transceiver should be used with 50 ohm to 75 ohm antennas having a low VSWR. Lightweight hookup wire dipoles and inverted vee's are sufficient for solid contacts. They can be quickly strung up for camping trips and emergency operation, as well as field day use. However, antennas of the beam and quad type will provide a significant improvement in performance, much more so than for medium to high-power rigs.

The "ARRL Antenna Book" is commonly available and includes comprehensive reference work on transmission lines and antennas. Other similar handbooks for the amateur are offered for sale and can often be found in a public library.

- ( ) Push in the Band switch for the band you intend to operate on.
- ( ) Turn the Transceiver on by rotating the AF GAIN control clockwise until it "clicks" on. Then continue to rotate the control clockwise to a comfortable listening level.
- ( ) Adjust the Main Tuning to the portion of the band where you intend to operate.

NOTE: When tuning across the band, always go to the high end of the band first and tune down to the low end. This is to assure that you will be on the high side of the zero beat when listening to a signal. Otherwise you may answer a CQ on the low side of zero beat and your transmitting frequency will be too low.

- ( ) Listen to the headphones and adjust the RECEIVER PRESELECTOR for maximum signal loudness (fully clockwise for 15 and 20 meter operation).
- ( ) Key the Transceiver and rotate the LOADING control to obtain a maximum meter indication. The Transceiver is now ready for on-the-air operation.

## OPERATING HINTS

When operating a QRP (low power) rig, your transmitted signal may be below the signal level preferred by most operators. Generally, lower power signals lose out unless a few simple techniques are followed. In many cases, listening for a CQ is more acceptable since your signal has a greater chance of being copied this way. Or you can try to contact a station just after he completes a contact. Also, be sure that you are on the high side of zero beat when you transmit as described previously.

Emergency operation is sometimes a necessity and always unexpected. The Transceiver is well suited for these situations if an antenna is available. A power source is usually no problem since any automobile battery or lantern

batteries of the appropriate voltage can provide hours of dependable operation. Refer to the "Specifications" section for voltage and current requirements.

You can vary the hold-in time of the antenna relay by adjusting BREAK-IN DELAY control R68 on the main circuit board. Adjust this control to obtain the desired delay after you have released the key.

Look for QRP operators on the following frequencies:

3.554 MHz	21.040 MHz
7.040 MHz	28.040 MHz
14.065 MHz	

# IN CASE OF DIFFICULTY

This part of the Manual will help you locate and correct any difficulties which might occur. This information is divided into:

Visual Checks.

Precautions for Bench Testing.

Troubleshooting Chart.

**NOTE:** If you prefer to have your Transceiver repaired at the factory or at one of the Heathkit Electronic Centers, or if you need additional information before you proceed, refer to the "Customer Service" information inside the rear cover of this Manual. Your Warranty is located inside the front cover.

## VISUAL CHECKS

1. About 90% of the kits that are returned for repair do not function properly due to poor soldering. Therefore, you can eliminate many troubles by a careful inspection of connections to make sure they are soldered as described on Page 6 of this Manual and in the "Kit Builders Guide." Reheat any doubtful connections and be sure all the wires are soldered at places where several wires are connected. Check carefully for solder bridges between circuit board foils.
2. Check to be sure that all transistors and diodes are in their proper locations, and are installed correctly.
3. Check the value of each part. Be sure that the proper part has been wired into the circuit, as shown in the Pictorial diagrams and as specified in the wiring instructions. It would be easy, for example, to install a 220  $\Omega$  (red-red-brown) resistor in a step that calls for a 22 k $\Omega$  (red-red-orange) resistor.
4. Recheck the wiring. Trace each lead in colored pencil on the Pictorial as you check it. It is frequently helpful to have a friend check your work. Someone who is not familiar with the unit may notice something you have consistently overlooked.
5. Check all of the wires that are connected to the circuit board to be sure they do not touch the chassis or other lugs. Make sure all wires are properly soldered.
6. A review of the "Circuit Description" may help you to determine the problem.
7. If the difficulty still is not cured, read the "Precautions for Bench Testing" section, and the section titled "Troubleshooting Charts."

## PRECAUTIONS FOR BENCH TESTING

NOTE: Use a high input impedance voltmeter for voltage measurements.

1. Be cautious when testing transistor circuits. Although transistors have almost unlimited life when used properly, they are much more vulnerable to damage from excessive voltage or current than other circuit components.
2. Be sure you do not short circuit any terminals when you make voltage measurements. If the probe should slip, for example, and short out a bias or voltage supply point, it is almost certain to damage one or more transistors or diodes.
3. Do not remove any components while the kit is operating; this could cause considerable damage.

If you make repairs to your Transceiver, make sure you eliminate the cause as well as the effect of the trouble. If, for example, you should find a damaged resistor, be sure to find out what caused the resistor to become damaged. If the cause is not eliminated, the replacement resistor may also become damaged when the Transceiver is put back into operation.



## Troubleshooting Chart

The following chart lists conditions and possible causes of several specific malfunctions. If a particular part is mentioned (Q7 for example) as a possible cause, check that part to see that it is installed and/or wired correctly. It is also possible, on rare occasions, for a part to be faulty and require replacement.

CONDITION	POSSIBLE CAUSE
No signals can be received on any band. However, headphone noise is heard when the AF Gain control is advanced.	1. Transistor Q1 or IC1 is incorrectly installed or shorted.
No signals are received on the 3.5 MHz band.	1. Diode D1 or D5 incorrectly installed or shorted.
No signals are received on the 7.0 MHz band.	1. Diode D2 or D6 incorrectly installed or shorted.
No signals are received on the 14.0 MHz band.	1. Diode D3 or D7 incorrectly installed or shorted.
No signals are received on the 21.0 MHz band.	1. Diode D4 or D8 incorrectly installed or shorted.
No sound of any kind from the headphones.	1. Transistor Q201 or IC2 incorrectly installed or shorted.  2. Phone jack J301 incorrectly wired.
Heterodyne frequency oscillator does not operate on any band.	1. Transistor Q6 incorrectly installed or shorted.
Heterodyne frequency oscillator does not operate on one band. (Other bands are OK.)	1. The associated diodes for the inoperative band (D22 thru D29) may be incorrectly installed or shorted.  2. The crystal for the inoperative band may be faulty.

## TROUBLESHOOTING CHART (cont'd.)

CONDITION	POSSIBLE CAUSE
Sidetone does not operate.	<ol style="list-style-type: none"> <li>1. Diode D21 or IC2 is incorrectly installed or shorted.</li> </ol>
Relay does not operate.	<ol style="list-style-type: none"> <li>1. Transistor Q12 or Q13 is incorrectly installed or shorted.</li> </ol>
Relative power meter does not operate.	<ol style="list-style-type: none"> <li>1. Trimmer capacitors, C95, C99, C103, C106, and C303 are not properly adjusted.</li> <li>2. Transistor Q8, Q9, or diode D301 are incorrectly installed or shorted.</li> </ol>
Relative power meter does not operate on one band only.	<ol style="list-style-type: none"> <li>1. The trimmer capacitor for that band (C95, C99, C103, or C106) is not properly adjusted.</li> <li>2. The diode associated with that band is incorrectly installed or shorted. (Diodes D16, D17, D18, D19, D31, D32, D33, D34, D35, D36, D37, or D38.)</li> <li>3. The heterodyne frequency oscillator is not properly tuned for that band.</li> </ol>

# SPECIFICATIONS

## TRANSMITTER

DC Power Input	
80 meters . . . . .	3.5 watts.
40 meters . . . . .	3.0 watts.
20 meters . . . . .	3.0 watts.
15 meters . . . . .	2.5 watts.
Frequency Control . . . . .	Built-in VFO.
Output Impedance . . . . .	50 $\Omega$ unbalanced.
Sidetone . . . . .	Built-in, adjustable volume.
Spurious and Harmonic Levels . . . . .	At least 35 db down.
Transmit Frequency Offset . . . . .	Approximately 750 Hz lower, fixed on all bands.

## RECEIVER

Receiver Type . . . . .	Direct conversion with RF amplifier, balanced product detector, and active audio filter.
Sensitivity . . . . .	1 microvolt or less for 10 dB $\frac{S+N}{N}$ . 0.2 $\mu$ V provides readable signal.
Selectivity . . . . .	Wide – 750 Hz @ 6 dB down. Narrow – 375 Hz @ 6 dB down.
Passband Center Frequency . . . . .	750 Hz.
Type of Reception . . . . .	CW.
Audio Output Impedance . . . . .	1000 $\Omega$ nominal.



### GENERAL

Frequency Coverage . . . . .	80 meters, 3.5 to 3.75 MHz. 40 meters, 7.0 to 7.25 MHz. 20 meters, 14.0 to 14.25 MHz. 15 meters, 21.0 to 21.25 MHz.
Frequency Stability . . . . .	Less than 150 Hz/hour drift after 60 minute warm-up.
Frequency Generation . . . . .	Premixed VFO and HFO.
Power Requirements . . . . .	13.4 volts DC, nominal. 90 mA receive mode, and 430 mA transmit mode.
Dimensions . . . . .	9-1/4" wide × 8-1/2" deep × 4-1/4" high, including knobs and feet. (23.5 × 21.6 × 10.8 cm.)
Weight . . . . .	4 lbs. (1.8 kg)

---

The Heath Company reserves the right to discontinue products and to change specifications at any time without incurring any obligation to incorporate new features in products previously sold.

# CIRCUIT DESCRIPTION

Refer to the Schematic Diagram and the Block Diagram in the Illustration Booklet while you read the following description.

The Transceiver operates in the CW portion of the 15, 20, 40, and 80 meter amateur bands. The frequencies are generated by the combined efforts of the VFO and the heterodyne oscillator for both transmit and receive operation. In the following paragraphs, each part of the Transceiver circuitry will be discussed in detail.

## VFO

FET (field effect transistor) Q2 and its associated circuitry forms a Hartley oscillator. Part of coil L9, tuning capacitor C302, and temperature compensating capacitors C44, C45, C46, C47, C48, C49, and C51 determine the frequency of the oscillator. The other part of L9 is a feedback circuit that couples part of the generated signal back to the gate of FET Q2 to help sustain oscillation. The VFO generates frequencies from 8.645 MHz to 8.895 MHz.

Diode D9 clamps the positive-going half of the signal to prevent FET Q2 from reaching high peak operating currents. This helps to keep the VFO from generating harmonic frequencies.

The signal from the VFO is coupled through capacitor C54 and C56 to emitter follower transistor Q3. This transistor provides isolation for the VFO. The output from the emitter of transistor Q3 is coupled to the balanced mixer.

When the Transmitter is keyed, diode D11 effectively adds capacitor C55 to the circuit which causes a shift in the VFO frequency. This produces a fixed offset during transmit. Zener diode ZD1 provides voltage regulation for the drain of FET Q2.

## HFO

The HFO operates at any of four crystal-controlled frequencies, depending on which band switch is depressed. These frequencies, when mixed with the VFO frequency, establish the four bands of operation.

When the 3.5 MHz pushbutton switch on the front panel is depressed, crystal Y1 and its associated circuitry are electrically connected to transistor Q6 to form the HFO. At this time power is supplied to the circuit through resistor R78 and crystal Y1 oscillates at a frequency of 12.395 MHz, which is coupled through diode D22 to transistor Q6. A part of the signal from the collector of transistor Q6 is coupled back through diode D23 and through the tuned circuit composed of coil L17 and capacitor C116 to sustain oscillation. Diodes D22 and D23 prevent DC from activating this crystal circuit when a different crystal circuit is being used. The HFO operates similarly on the other bands.

The HFO signal is coupled through capacitor C127 to emitter follower transistor Q7. This transistor provides isolation for the oscillator circuit to prevent loading. From the emitter of transistor Q7, the signal is coupled to the balanced mixer.

## BALANCED MIXER

Coils L11 and L12 and diodes D12, D13, D14, and D15 form a balanced mixer which combines the VFO and HFO signals. This produces four signals at the output of the balanced mixer. These are the VFO frequency plus the HFO frequency, the HFO frequency minus the VFO frequency, the VFO frequency, and the HFO frequency. The only frequency that we are concerned with is the HFO frequency minus the VFO frequency.

## MIXER AMPLIFIER

The four signals are then coupled through capacitor C61 to FET Q4 where they are amplified and then coupled to the four diode-selected filter circuits. Only one filter circuit is electrically connected to the circuit on any one band. For example, if the 3.5 MHz pushbutton switch on the front panel is depressed, coil L13 and capacitor C64 are electrically connected to the circuit. This tuned circuit filters out the three unwanted signals and leaves only the "on-frequency" signal, which is coupled through capacitor C73 to transistor Q5.

Transistor Q5 is connected as an emitter follower which provides isolation and impedance matching. The output from the emitter of Q5 is coupled through C75 to transistor Q8 and also through capacitor C28 to balanced product detector IC1.

## TRANSMITTER

The output of driver transistor Q8 is resonance-tuned by the appropriate diode-switched tuned circuit. Here again, there are four tuned circuits. Only one tuned circuit is electrically connected to the output of Q8 for each band of operation. For the 3.5 MHz band, coil L22 and capacitor C77 and C78 are connected through diodes D31 and D35.

The output from the driver is coupled to final amplifier transistor Q9. Here the signal is amplified and then coupled through the appropriate switch (part of the depressed front panel switch) to the output circuit, which acts as a bandpass filter and impedance matching network.

Zener diode ZD2 prevents excessive collector RF voltage from destroying transistor Q9 if the operator should mistakenly key the transmitter when there is no load present on the output of the Transmitter, or when the SWR is high.

Capacitor C303 is the Loading control and is adjusted for maximum power on the relative power meter. The RF power output is then coupled through antenna switching relay RL1 and to antenna jack J302. A small part of the RF power output is coupled through resistor R304, and capacitor C304 to the relative power meter. This output power is rectified by diode D301.

## KEYING

Transistor Q11 provides a keying function when the key is depressed. This transistor provides the keying for the transmitter driving stage, the sidetone oscillator, the break-in delay switching, and the receiver muting. When the key is depressed, the keying transistor places a B+ voltage on the collector of driver transistor Q8 and switches it on. The transmitter is then keyed and provides an RF output signal.

Also, when the key is depressed, pin 11 of sidetone oscillator IC2D is connected to ground through resistor R72 and diode D21 and the key to cause the oscillator to turn on and generate an audible tone. This tone is coupled through capacitor C111, resistor R76, Sidetone Level Adjust control R77, and capacitor C113 to the headphone jack.

## BREAK-IN DELAY

Transistors Q12 and Q13 provide an adjustable delay circuit for antenna switching and receiver muting. The emitter of break-in delay transistor Q12 is connected to ground when the key is depressed. This effectively puts the collector of Q12 at ground potential, which causes relay driver transistor Q13 to energize relay RY1 and switch the antenna from receive to transmit. Relay RY1 will remain energized until the base voltage of relay driver transistor Q13 increases to the B+ voltage. The key also turns transistor Q11 on and off which switches the Transceiver between transmit and receive.

The B+ voltage at the relay is used to switch VFO offset diode D11 to provide offset during transmit and also to switch the mute transistor Q14 on. This effectively connects the input of the audio preamplifier stage to ground, thus muting the receiver during transmit.

When the key is released, the emitter and collector voltages of Q12 try to increase toward B+. However, at this time, capacitor C92 is discharging through delay control R68, which keeps the relay energized. After capacitor C92 has discharged and the voltage on the collector of Q13 returns to normal, the relay opens. The amount of time required for capacitor C92 to discharge is adjustable through delay control R68.

## RECEIVER CIRCUITS

The signals received by the antenna are coupled through RF Gain control R302 and through the appropriate front panel pushbutton switch (for example we will say the 3.5 MHz band switch). From here, the signal is coupled through coil L1 and diode D1 to RF amplifier Q1. Coil L1 and capacitors C1, C3, and C301A form a resonant circuit. Diode D1 provides the electrical switching to connect the signal to FET Q1 when the 3.5 MHz switch is depressed.

The signal is amplified by FET Q1 and is filtered by one of the coil-capacitor networks. (Each network serves as a filter for one of the four bands.) This filtered signal is then coupled through capacitor C25 to pin 1 of IC1, the balanced product detector. IC1 mixes the premixed VFO signal with the received signal to produce an audio signal. This signal is present at pin 9 of IC1 and is coupled through capacitors C33, C35, and resistor R19 to pin 3 of IC2A.

IC2A and IC2B are active audio filters. The audio signal passes through these two stages of audio filtering, which removes any RF signal and produces an audio signal that has good audio bandwidth and excellent skirt selectivity. There are two stages of audio selectivity which are selected by Selectivity switch SW302 on the front panel.

From the Selectivity switch, the signal is coupled through capacitor C38 to IC2C. IC2C is an audio preamplifier which amplifies the signal and then couples it through resistor R202 and capacitor C201 to transistor Q201. Transistor Q201 further amplifies the signal and then it is coupled through capacitor C204 to headphone jack J301.

# CIRCUIT BOARD X-RAY VIEWS

NOTE: To find the PART NUMBER of a component for the purpose of ordering a replacement part:

- A. Find the circuit component number (R5, C3, etc.) on the "Circuit Board X-Ray Views."
- B. Locate this same number in the "Circuit Component Number" column of the "Parts List" in the front of this Manual.
- C. Adjacent to the circuit component number, you will find the PART NUMBER and DESCRIPTION which must be supplied when you order a replacement part.

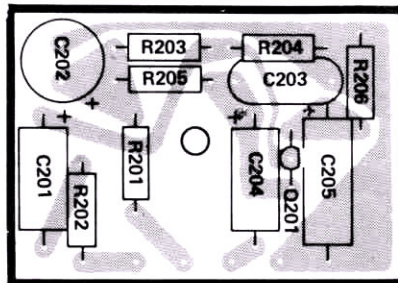

AF AMPLIFIER CIRCUIT BOARD  
(Viewed from foil side)



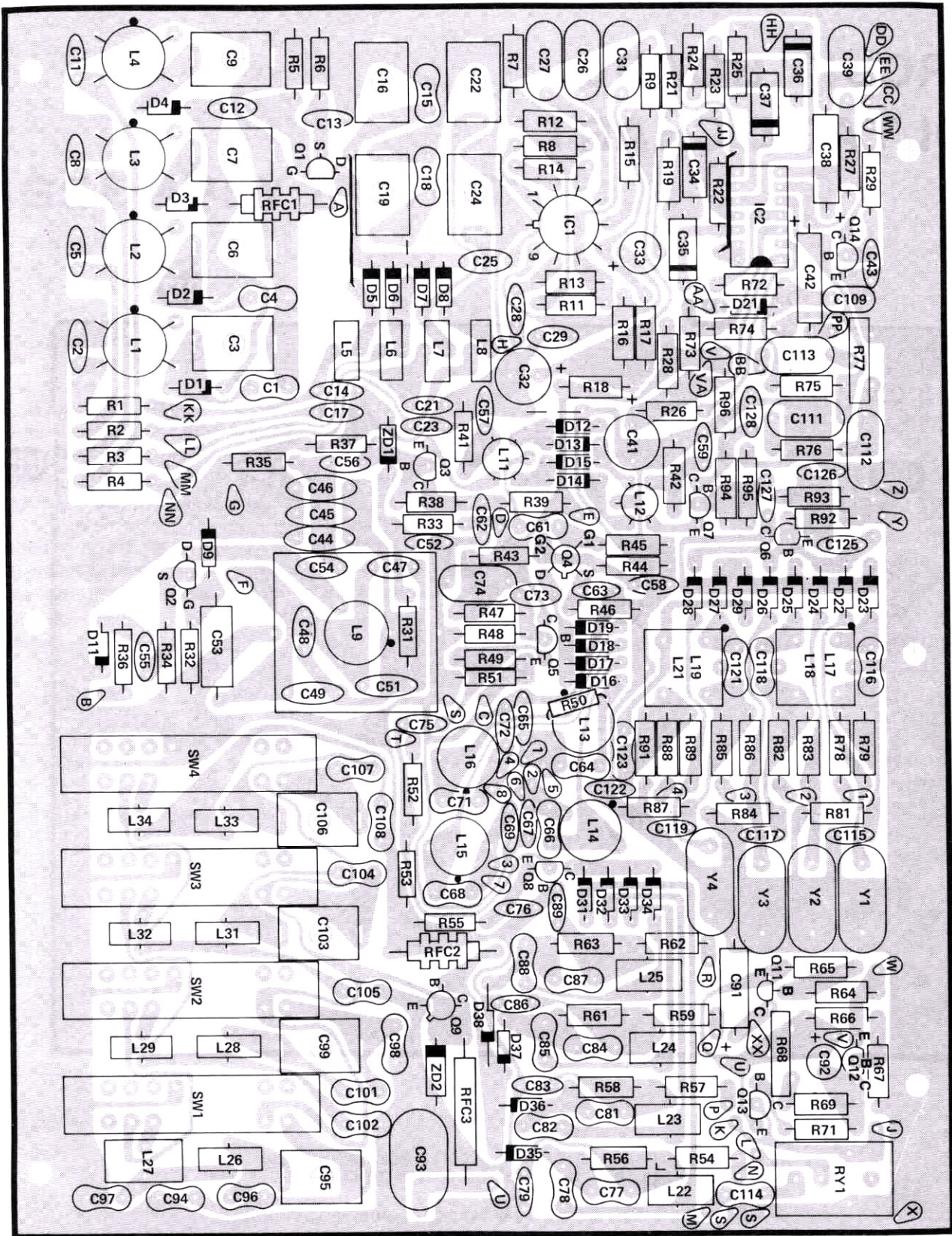

MAIN CIRCUIT BOARD  
(Viewed from foil side)

# CIRCUIT BOARD VOLTAGE CHART

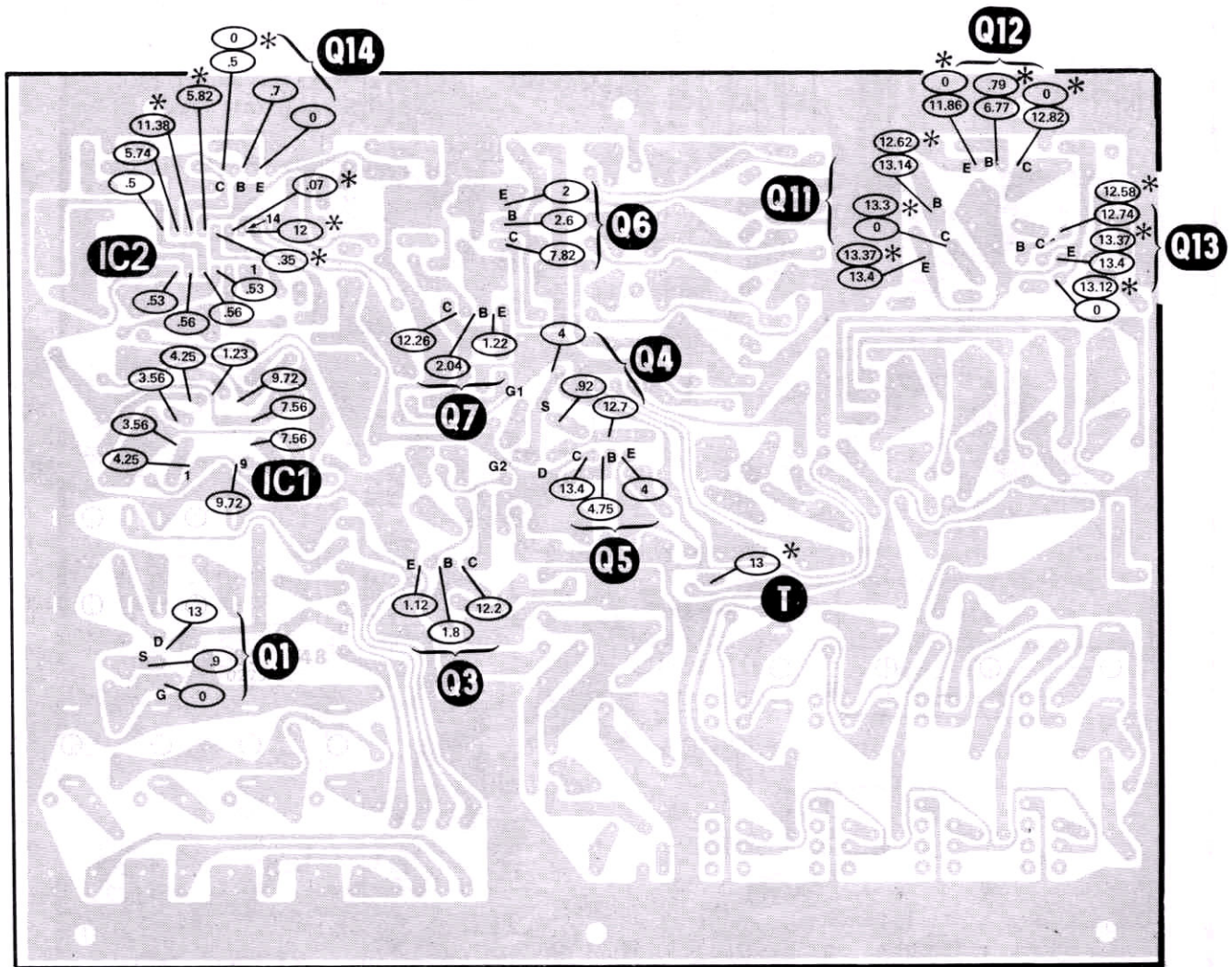

- THIS SYMBOL INDICATES A RECEIVE-MODE DC VOLTAGE MEASURED FROM THE POINT INDICATED TO CHASSIS.
- \* THIS SYMBOL INDICATES A TRANSMIT-MODE DC VOLTAGE MEASURED FROM THE POINT INDICATED TO CHASSIS.

# IDENTIFICATION CHART

COMPONENT	HEATH PART NUMBER	TYPE NUMBER	IDENTIFICATION
Q13	417-201	X29A829	
Q1, Q2	417-169	MPF105	
Q11	417-116	S2091	
Q6, Q8	417-172	MPS-6521	
Q3, Q5, Q7, Q12, Q14, Q201	417-801	MPS-A20	
Q4	417-240	40673	
Q9	417-880	2N4427	

## IDENTIFICATION CHART (Cont'd)

COMPONENT	HEATH PART NUMBER	TYPE NUMBER	IDENTIFICATION
IC2	442-71	LM3900	
IC1	442-96	MC1496	 (BOTTOM VIEW)
ZD1	56-19	VR-9.1	<p><b>IMPORTANT: THE BANDED END OF DIODES CAN BE MARKED IN A NUMBER OF WAYS.</b></p> <p><b>BANDED END</b></p>
ZD2	56-55	VR-36	
D12, D13, D14, D15	56-87	FH100	
D1, D2, D3, D4, D5, D6, D7, D8, D9, D10, D11, D16, D17, D18, D19, D21, D31, D32, D33, D34, D35, D36, D37, D38	56-24	1N458	
D22, D23, D24, D25, D26, D27, D28, D29,	56-56	1N4149	

**FOR PARTS REQUESTS ONLY**

- Be sure to follow instructions carefully.
- Use a separate letter for all correspondence.
- Please allow 10 - 14 days for mail delivery time.

**DO NOT WRITE IN THIS SPACE**

**INSTRUCTIONS**

- Please print all information requested.
- Be sure you list the correct **HEATH** part number exactly as it appears in the parts list.
- If you wish to prepay your order, mail this card and your payment in an envelope. Be sure to include 10% (25¢ minimum, \$3.50 maximum) for insurance, shipping and handling. Michigan residents add 4% tax.
- If you prefer COD shipment, check the COD box and mail this card.

Total enclosed \$ \_\_\_\_\_

COD

NAME \_\_\_\_\_

ADDRESS \_\_\_\_\_

CITY \_\_\_\_\_

STATE \_\_\_\_\_ ZIP \_\_\_\_\_

The information requested in the next two lines is not required when purchasing nonwarranty replacement parts, but it can help us provide you with better products in the future.

Model # \_\_\_\_\_ Invoice # \_\_\_\_\_

Date \_\_\_\_\_ Location \_\_\_\_\_

Purchased \_\_\_\_\_ Purchased \_\_\_\_\_

LIST <b>HEATH</b> PART NUMBER	QTY.	PRICE EACH	TOTAL PRICE

TOTAL FOR PARTS

HANDLING AND SHIPPING

MICHIGAN RESIDENTS ADD 4% TAX

**TOTAL AMOUNT OF ORDER**

SEND TO: **HEATH COMPANY**  
BENTON HARBOR  
MICHIGAN 49022  
**ATTN: PARTS REPLACEMENT**

Phone (Replacement parts only): 616 982-3571

THIS FORM IS FOR U.S. CUSTOMERS ONLY  
OVERSEAS CUSTOMERS SEE YOUR DISTRIBUTOR

**FOR PARTS REQUESTS ONLY**

- Be sure to follow instructions carefully.
- Use a separate letter for all correspondence.
- Please allow 10 - 14 days for mail delivery time.

**DO NOT WRITE IN THIS SPACE**

**INSTRUCTIONS**

- Please print all information requested.
- Be sure you list the correct **HEATH** part number exactly as it appears in the parts list.
- If you wish to prepay your order, mail this card and your payment in an envelope. Be sure to include 10% (25¢ minimum, \$3.50 maximum) for insurance, shipping and handling. Michigan residents add 4% tax.
- If you prefer COD shipment, check the COD box and mail this card.

Total enclosed \$ \_\_\_\_\_

COD

NAME \_\_\_\_\_

ADDRESS \_\_\_\_\_

CITY \_\_\_\_\_

STATE \_\_\_\_\_ ZIP \_\_\_\_\_

The information requested in the next two lines is not required when purchasing nonwarranty replacement parts, but it can help us provide you with better products in the future.

Model # \_\_\_\_\_ Invoice # \_\_\_\_\_

Date \_\_\_\_\_ Location \_\_\_\_\_

Purchased \_\_\_\_\_ Purchased \_\_\_\_\_

LIST <b>HEATH</b> PART NUMBER	QTY.	PRICE EACH	TOTAL PRICE

TOTAL FOR PARTS

HANDLING AND SHIPPING

MICHIGAN RESIDENTS ADD 4% TAX

**TOTAL AMOUNT OF ORDER**

SEND TO: **HEATH COMPANY**  
BENTON HARBOR  
MICHIGAN 49022  
**ATTN: PARTS REPLACEMENT**

Phone (Replacement parts only): 616 982-3571

THIS FORM IS FOR U.S. CUSTOMERS ONLY  
OVERSEAS CUSTOMERS SEE YOUR DISTRIBUTOR

CUT ALONG DOTTED LINE

# CUSTOMER SERVICE

## REPLACEMENT PARTS

Please provide complete information when you request replacements from either the factory or Heath/Zenith Computers and Electronics centers. Be certain to include the **HEATH** part number exactly as it appears in the parts list.

## ORDERING FROM THE FACTORY

Print all of the information requested on the parts order form furnished with this product and mail it to Heath. For telephone orders (parts only) dial 616 982-3571. If you are unable to locate an order form, write us a letter or card including:

- Heath part number.
- Model number.
- Date of purchase.
- Location purchased or invoice number.
- Nature of the defect.
- Your payment or authorization for COD shipment of parts not covered by warranty.

Mail letters to: Heath Company  
Benton Harbor  
MI 49022  
Attn: Parts Replacement

**Retain original parts until you receive replacements. Parts that should be returned to the factory will be listed on your packing slip.**

## OBTAINING REPLACEMENTS FROM HEATH/ZENITH COMPUTER AND ELECTRONICS CENTERS

For your convenience, "over the counter" replacement parts are available from the Heath/Zenith Computer and Electronics centers listed in your catalog. Be sure to bring in the original part and purchase invoice when you request a warranty replacement from a Heath/Zenith Computer and Electronics center.

## TECHNICAL CONSULTATION

Need help with your kit? — Self-Service? — Construction? — Operation? — Call or write for assistance. You'll find our Technical Consultants eager to help with just about any technical problem except "customizing" for unique applications.

The effectiveness of our consultation service depends on the information you furnish. Be sure to tell us:

- The Model number and Series number from the blue and white label.
- The date of purchase.
- An exact description of the difficulty.
- Everything you have done in attempting to correct the problem.

Also include switch positions, connections to other units, operating procedures, voltage readings, and any other information you think might be helpful.

**Please do not send parts for testing**, unless this is specifically requested by our Consultants.

Hints: Telephone traffic is lightest at midweek — please be sure your Manual and notes are on hand when you call.

Heath/Zenith Computer and Electronics center facilities are also available for telephone or "walk-in" personal assistance.

## REPAIR SERVICE

Service facilities are available, if they are needed, to repair your completed kit. (Kits that have been modified, soldered with paste flux or acid core solder, cannot be accepted for repair.)

**If it is convenient, personally deliver your kit to a Heath/Zenith Computers and Electronics center. For warranty parts replacement, supply a copy of the invoice or sales slip.**

If you prefer to ship your kit to the factory, attach a letter containing the following information directly to the unit:

- Your name and address.
- Date of purchase and invoice number.
- Copies of all correspondence relevant to the service of the kit.
- A brief description of the difficulty.
- Authorization to return your kit COD for the service and shipping charges. (This will reduce the possibility of delay.)

Check the equipment to see that all screws and parts are secured. (Do not include any wooden cabinets or color television picture tubes, as these are easily damaged in shipment. Do not include the kit Manual.) Place the equipment in a strong carton with at least **THREE INCHES** of *resilient* packing material (shredded paper, excelsior, etc.) on all sides. Use additional packing material where there are protrusions (control sticks, large knobs, etc.). If the unit weighs over 15 lbs., place this carton in another one with 3/4" of packing material between the two.

Seal the carton with reinforced gummed tape, tie it with a strong cord, and mark it "Fragile" on at least two sides. Remember, the carrier will not accept liability for shipping damage if the unit is insufficiently packed. Ship by prepaid express, United Parcel Service, or insured Parcel Post to:

Heath Company  
Service Department  
Benton Harbor, Michigan 49022



HEATH COMPANY • BENTON HARBOR, MICHIGAN  
*THE WORLD'S FINEST ELECTRONIC EQUIPMENT IN KIT FORM*

LITHO IN U.S.A.