

Congratulations on your purchase of the JST-145/245 transceiver.

The JST-145/245 is a high-quality, high-performance transceiver utilizing the latest innovative circuits and semiconductors developed from Japan Radio Company's many years of experience and achievements in the field of radio communications and information received from the many users of the JST-135. We encourage you to carefully read through this manual before using your radio.

Your JST-145/245 has been produced under the strictest quality control methods. Should you have any problems or find any damage, please contact your nearest authorized JRC dealer as soon as possible.

NOTICE

Operation of a radio transmitting device is usually controlled by a governmental regulating agency in each country. Users are kindly requested to operate their radio equipment in such a manner that is legally and socially accepted.

Responsibility for any incidents caused by unauthorized or improper operation of a radio station rests with the licence holder or user.

Accessories

Please check that the following accessories are packed with your new JST-145 or JST-245.

- ① Instruction Manual 1
- ② Accessory connector (25-pin) 1
- ③ Linear amp connector (15-pin) 1
- ④ Fuse (10A) 2
- ⑤ AC cable 1

Please retain packing materials in case you need them for returning the product for after-service.

CONTENTS

Section 1. Features	1
Section 2. Specification	3
Section 3. Set up	5
3.1 Installation Location	5
3.2 Connections	5
Section 4. Operating Controls	7
4.1 Front Panel (Part 1)	7
4.2 Front Panel (Part 2)	10
4.3 The Numeric Keypad	12
4.4 Frequency Controls	13
4.5 Rear Panel	15
Section 5. Basic Operation	18
5.1 Preliminary Settings	18
5.2 Frequency Setting	18
5.3 Operation In SSB Mode	19
5.4 Operation In CW Mode	19
5.5 Operation In AM Mode	20
5.6 Operation In FM Mode	21
5.7 Operation In AFSK Mode	21
5.8 Switching Antenna Connections	21
Section 6. Operation	22
6.1 Memory Functions	22
6.2 Using Memory Channels	22
6.3 Simplex Operation	23
6.4 Split Operation	24
6.5 Interference Elimination Functions	25
6.6 Scanning	27
6.7 Antenna Tuner Operation	28
6.8 Voice Operated Transmission (VOX) Operation	28
6.9 Microphone Compressor	29
6.10 Break-In Operation	29
6.11 Synchronizing Frequency In CW Mode	30
6.12 Built-In Electric Keyer	30
6.13 Repeater Operation	30
6.14 Tone Squelch Operation	31
6.15 Code Squelch Operation and Paging	32
6.16 Filter Combinations	34
6.17 Connecting Peripheral Equipment	35
6.18 User Definitions	36
6.19 PC Control of the Transceiver	40
Section 7. Adjustments and Maintenance	48
Section 8. Notes on Operation	51
Section 9. Troubleshooting	52
9.1 Troubleshooting in Reception	52
9.2 Troubleshooting on Transmission	53
Section 10. Peripheral Equipment and Options	54
Section 11. Block Diagram	56
Section 12. Circuit Diagrams	58

Section 1. Features

— The Pursuit of Basic Performance and Ease-of-Use —

1. Large LCD display and easy-to-use control panel

JRC has developed a large color LCD that not only visually displays the frequency, mode, and IF bandwidth but also the RIT/XIT volume and respective metering. For quick QSY, the frequency controls such as band selector key, VFO A/B switch, 10Hz-step RIT/XIT control, and SPLIT key, are as large as space will permit and have been positioned for optimum ease-of-use. Users will find the large LCD and controls invaluable when using the set during contests, etc.

2. Power amplifier with MOSFET SEPP circuit

MOSFET SEPP (Single-Ended Push-Pull) circuits are used in the driver and final stages, providing coverage from 1.9MHz to 50MHz (28MHz in the JST-145) from a single PA with exceptionally low distortion. Further, the suppression of high-order harmonics means fewer problems such as TVI.

3. Variable tuning system for excellent reception

The JST-145/245 uses the same front-end variable tuning system (in which the double tuning circuit with capacitor diodes is under CPU control) incorporated in JRC's professional receivers. This system greatly reduces undesired out-of-band signals and improves the set's multi-signal characteristics.

4. Preset-type high-speed antenna tuner for quick QSY (1.9MHz band to 28MHz band)

In contrast to the conventional motor-driven variable-capacitor-type, the JST-245 uses an automatic antenna tuner with preset memory in which a relays switch capacitors and coils. (Optional with the JST-145)

5. Heavy-duty design

An FET PA with its intrinsic resistance to overloading, a high-efficiency power supply, and a cooling system with effective heat sinks guarantee stable operation for long periods.

6. Immediate panel switching between 3 antenna connectors

To enable selection of the optimum antenna to suit band and conditions, the JST-145/245 is equipped with three antenna terminals, which can be switched from the front panel. Information on the antenna used is stored in memory.

7. New DDS IC for low noise and smooth tuning

With its minimum 2Hz increment, JRC's unique direct digital synthesizer (DDS) provides local signals with low phase noise. A single reference oscillator is used for all local frequencies, achieving outstanding frequency stability.

8. Advanced interference rejection techniques

• Bandwidth control (BWC)

The passband of the reception IF filter is continuously variable to eliminate interference. (Optional on JST-145)

• Passband shift (PBS)

The apparent center frequency of the reception IF filter can be shifted up or down to eliminate interference.

• Noise blanker (NB)

The JST-145/245's noise blanker eliminates different types of noise, from narrow noise such as ignition noise through to wide noise.

• Notch filter (NOTCH) and notch tracking (NOTCH TRACKING) filters

The notch filter attenuates beat interference adjacent to the desired signal. Notch tracking is used to track interference.

• Reverse (REV)

This function reverses the received audio spectrum to provide improved listening quality if there is interference in CW mode.

9. Memory

• Band memory

Each band memory stores not only frequency, mode, IF bandwidth, and AGC but also which of the three antennas was used. It is therefore possible at QSY to immediately shift to the last operating status for each band.

- **200-channel memory**

The JST-145/245 provides a wide range of operations fully utilizing the 200-channel memory, which stores information such as frequency, mode, filters, AGC, antenna, split, shift, tone SQ, and RF AMP ON/OFF.

10. RS-232C port (standard) for remote control from a PC

Both JST-145 and JST-245 are provided with RS-232C ports, allowing most functions except the power switch to be controlled from a PC. Further, the current settings can be sent to the PC, providing great flexibility in establishing application systems.

Section

General

- Transmissions
 - 1.8MHz
 - 3.5MHz
 - 7MHz
 - 10MHz
 - 14MHz
 - 18MHz
 - 21MHz
 - 24MHz
 - 28MHz
 - 50MHz
- Reception
 - 100kHz
 - 30 to 54MHz
- Modes
 - SSB (LSB)
 - CW
 - AM (A3E)
 - FM
 - AFSK
- Frequency stability
 - Better than ±0.5Hz
 - Thereafter ±0.1Hz
- Minimum tuning interval
 - 2Hz
- Memory capacity
 - 200 channels
- Antenna impedance
 - 50 Ω (unbalanced)
- Input voltage
 - JST-145D: 85 to 132V
 - JST-145D: 170 to 264V
- Power consumption
 - Receive (w/antenna): 1.5W
 - Transmit: 10W
- Dimensions
 - 350mm (W) x 150mm (H) x 100mm (D)
 - (365mm x 160mm x 110mm)
- Weight
 - Approx. 12kg

Section 2. Specifications

General

- Transmission frequency range
 - 1.8MHz band 1.8 to 2.0MHz (160m)
 - 3.5MHz band 3.5 to 4.0MHz (80m)
 - 7MHz band 7.0 to 7.3MHz (40m)
 - 10MHz band 10.1 to 10.15MHz (30m)
 - 14MHz band 14.0 to 14.35MHz (20m)
 - 18MHz band 18.068 to 18.168MHz (17m)
 - 21MHz band 21 to 21.45MHz (15m)
 - 24MHz band 24.89 to 24.99MHz (12m)
 - 28MHz band 28.0 to 29.7MHz (10m)
 - 50MHz band 50.0 to 54.0MHz (6m) (JST-245 only)
- Reception frequency range
 - 100kHz to 30MHz
 - 30 to 54MHz (JST-245 only)
- Modes
 - SSB (LSB, USB)
 - CW
 - AM (A3H)
 - FM
 - AFSK
- Frequency stability
 - Better than ± 10 ppm 5 min. to 60 min. after switching ON
 - Thereafter, better than ± 2 ppm
- Minimum tuning increment
 - 2Hz
- Memory capacity
 - 200 channels
- Antenna impedance
 - 50 Ω (unbalanced)
- Input voltage
 - JST-145DXU/245DXU
 - 85 to 132 VAC, 50/60Hz single phase
 - JST-145DXG/245DXG
 - 170 to 264 VAC, 50/60Hz single phase
- Power consumption
 - Receive (with no signal): Approx. 90VA
 - Transmit: Approx. 900VA (at 150W output by JST-145DX/245DX)
- Dimensions
 - 350mm (W) x 130mm (H) x 305mm (D)
 - (365mm x 134mm x 345mm including projections)
- Weight
 - Approx. 12kg

Transmitter

- Output power
 - JST-145DX and JST-245DX: 15 to 150W, continuously adjustable
- Modulation
 - SSB, AM(A3H), and AFSK: Balanced modulation
 - FM: Reactance modulation
- Carrier suppression ratio
 - 50dB or more
- Undesired sideband suppression ratio
 - 60dB or more
- Spurious emission
 - 40dB or less
- 3rd order intermodulation distortion
 - 38dB or less
- Frequency response
 - 400 to 2600Hz (within 6dB, SSB)
- Maximum frequency deviation *
 - ± 5 kHz
- Microphone impedance
 - 600 Ω

Receiver

- Receiving system
 - SSB, CW, AM, and AFSK: Quadruple superheterodyne
 - FM: Triple superheterodyne
- Intermediate frequencies
 - 1st IF: 70.445MHz
 - 2nd IF: 9.455MHz
 - 3rd IF: 455kHz
 - 4th IF: 97kHz
- Sensitivity

	SSB, CW, AFSK	AM	FM
0.1 to 0.5 MHz	4 $5\mu V$ 14dB μ	15.8 24dB μ	-
0.5 to 1.6 MHz	2 6dB μ	6.3 μV 16dB μ	-
1.6 to 30 MHz	-10dB μ	6dB μ	-6dB μ
48 to 54 MHz	-10dB μ 0.32	6dB μ	-6dB μ

(SSB, CW, AFSK, and AM at 10dB S/N; FM at 12dB SINAD)

- Image rejection: 70dB or more

$-10.4 \text{ dB} \mu = 0.3 \mu V$
 $-4.4 = 0.6 \mu V$
 $-1.0 = 0.9 \mu V$
 $0 = 1.0 \mu V$

$-3.2 = 0.7 \mu V$
 $9.5 = 3.0 \mu V$
 $3.5 = 1.5 \mu V$

- IF rejection: 70dB or more
- Selectivity

	- 6dB	- 60dB
SSB, CW(W), AFSK (INTER)	2.4kHz or more	4.0kHz or less
FM (WIDE)	12kHz or more	-
AM (INTER)	6kHz or more	18kHz or less

RIT/XIT range: $\pm 10\text{kHz}$

PBS range: $\pm 1\text{kHz}$

Notch filter attenuation: Approx. 40dB

Maximum audio output: 1W or more

(Ratings are standard values using the JAJA measuring methods.)

(Ratings and circuits subject to change without prior notice.)

Se

3.1 I

Select
Avoid a
sunlight
taken to
the great

CAUTION
Connect ext
devices wit
POWER sw
OFF.

Headpho

Connect he
to the PHC
jack.

Refer to section
17, "Connect
Peripheral Dev

Ground

Ground the
terminal se
to prevent
shock and

Key conn

Connect a
the KEY o

Section 3. Setup

3.1 Installation Location

Select a well-ventilated area for installing your JST-145/245. Avoid areas where the equipment would be exposed to direct sunlight, dust, vibration, moisture, etc. Special care should be taken to ensure sufficient ventilation behind the unit, as this is the greatest source of heat.

3.2 Connections

Make all connections as shown in Figure 3.1. Be sure that the POWER switch is turned OFF before making these connections.

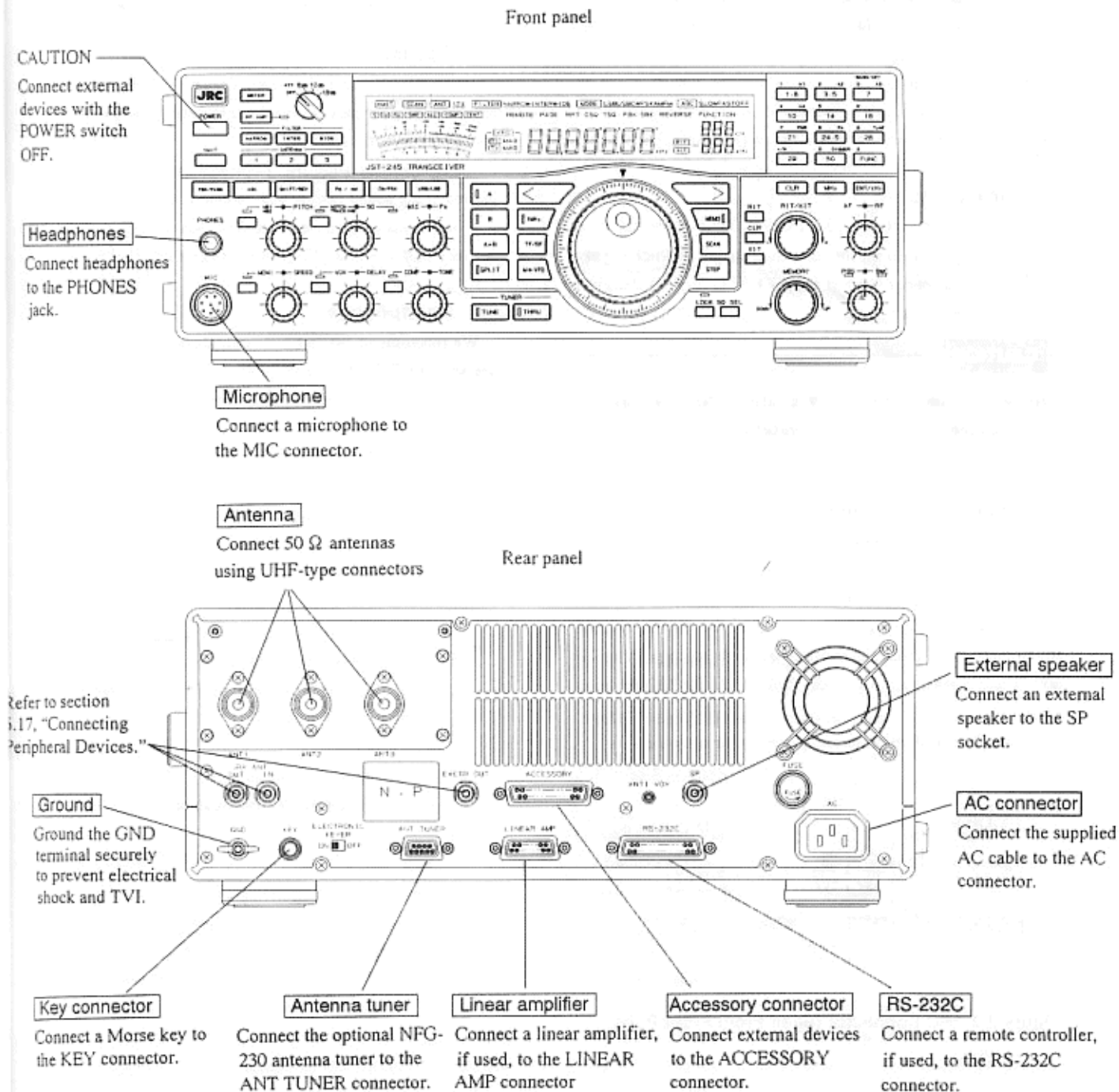

Figure 3.1 Basic Connections of Front and Rear Panels

3.2.1 Power Supply

The JST-145/245 operates between 85V and 132V on the 100VAC system and between 170V and 264V on the 200VAC system. A power capacity of approximately 10A is required for the 150W models (JST-145DX and 245DX).

Plug the supplied AC power cable securely into the wall outlet.

3.2.2 Antenna

The antenna impedance of the JST-145/245 is designed for 50 Ω antennas. Note that use of an unmatched antenna may prevent the rated output being achieved and be a source of TVI and BCI.

The JST-245 has a built-in antenna tuner, which match an antenna for an SWR 3:1 or better. If using antennas such as long wires, use the optional NFG-230 antenna tuner.

3.2.3 Grounding

Be sure to connect the JST-145/245 GND terminal to a proper earth ground using the minimum length of thick copper wire or braided copper strap or copper tape to prevent electrical shock and interference.

CAUTION

Never connect grounding systems to any gas pipe, cable duct, or plastic water pipe.

3.2.4 Microphone Connection

When using the JST-145/245 in SSB, AM, or FM mode, connect a microphone to the MIC connector on the front panel. Figure 3.2 shows the JST-145/245 microphone pin assignment.

When using a microphone other than the listed optional equipment, use a dynamic microphone with an impedance of 600 Ω and a sensitivity of -70dB (0dB: 1V/ $\sqrt{\text{BAR1000Hz}}$) or greater.

Use an FM-14-8P microphone connector or equivalent.

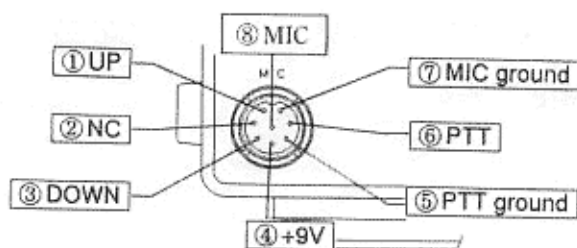

Figure 3.2 MIC Connector (Seen From Front Panel)

3.2.5 Key Connection

For CW operation, plug a Morse key into the KEY connector on the rear panel. Use the 2-pin KEY plug on sale.

To use the built-in electric keyer, refer to Section 6.12, "The Built-In Electric Keyer" for details.

CAUTION

Do not apply excessively high or negative voltage. The CW keying circuits of the JST-145 and JST-245 operate on the +5V TTL level.

3.2.6 Speaker

The JST-145 and JST-245 are provided with built-in speakers. The SP jack ⑭ on the rear panel can also be used to connect an external speaker.

We recommend using JRC's optional external speaker, which has matching sound quality and volume characteristics.

When using a non-JRC speaker, select one with an impedance of 4 to 8 Ω and a maximum input of 3 to 5W.

3.2.7 Headphones

We recommend JRC's ST-3 communications headphones for use with the JST-145 and JST-245.

You can also use normal headphones for stereos.

3.2.8 Other Connections

Please refer to 6.17, "Connecting Peripheral Equipment" for information on connecting a linear amplifier or other peripherals.

Section 4. Operating Controls

4.1 Front Panel (Part 1)

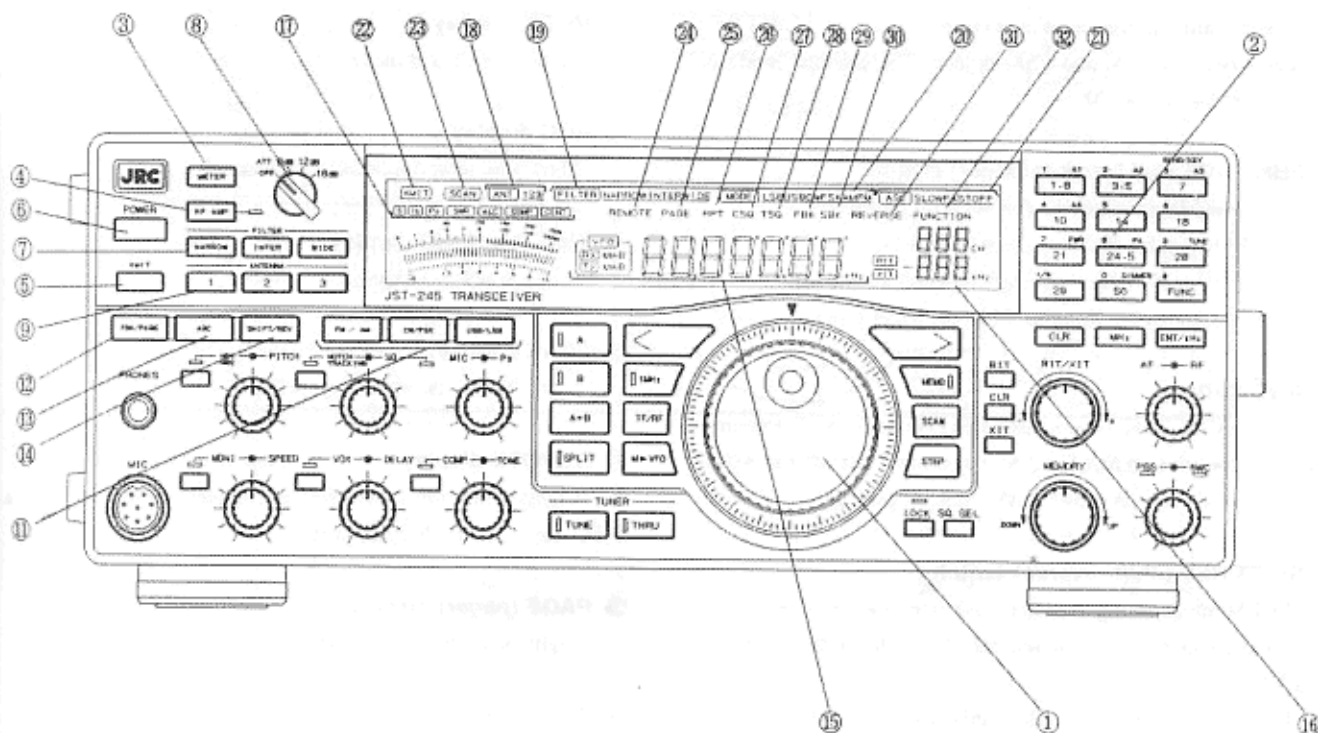

Figure 4.1 Front Panel (Part 1)

① Tuning control

Adjusts transmitting and receiving frequencies, and also used for fine adjustment, for VFO selection, and to specify splits. See **Section 4.4, "The Tuning Control"** for details.

② Numeric keypad

Switches bands, selects frequency, and switches functions. See **Section 4.3, "The Numeric Keypad"** for details.

③ METER switch

Switches transmission metering. Use this switch when transmitting to select the item displayed on the meter ⑩.

④ RF AMP switch

Switches the receiving RF amplifier on and off. The LED to the right of the switch lights when the RF amp is on. The RF amplifier is normally on for reception, but should be turned off if you experience interference or intermodulation distortion

within a particular band.

⑤ XMIT (transmit) switch

Press to transmit. Press again to return to receiving. The XMIT lamp ⑫ lights when transmitting.

⑥ POWER switch

⑦ FILTER switch

Switches transmit and receive IF bandwidths. The result is shown on the display ⑮. See **Section 6.16** for details of displays and IF bandwidths.

⑧ ATT (RF attenuator) switch

Adjusts attenuation of the RF attenuator at the front end of the receiver. Use this switch to improve reception if there is band noise from IM or interference, or when there is strong interference from local radio stations.

⑨ **ANTENNA switch**

Switches among the three antenna terminals. The current antenna is shown on the display ⑩.

You cannot switch antennas during transmission.

⑩ **MODE switches**

Switch among modes. For example, pressing **CW/FSK** toggles between CW and FSK modes. The selected mode is shown on the display ⑩.

⑪ **FBK/PAGE (full break-in/pager) switch**

In CW mode, switches the full break-in on and off.

The FBK display ⑫ lights when FBK is ON.

In FM mode, switches the pager function on and off.

The PAGE display ⑬ lights when the pager function is ON.

⑬ **AGC switch**

Toggles the AGC time constant SLOW and FAST. Pressing and holding this switch for 2 to 3 seconds turns off the AGC. The selected status is shown in the AGC display ⑭.

⑭ **SHIFT/REV (shift/reverse) switch**

In FM mode using repeater operation, switches the transmission frequency shift on and off. When the shift is ON, the RPT (repeater) display ⑮ lights.

In CW and AFSK modes, this switch toggles spectral reversal on and off. The REVERSE lamp ⑯ lights when the spectrum is reversed.

⑮ **Frequency display**

Displays the reception frequency when receiving and the transmission frequency when transmitting.

The display also shows whether A or B VFO is used for receiving and transmitting, or whether memory is used.

⑯ **Memory channel and RIT/XIT display**

The upper part shows the memory channel. The lower part shows the RIT/XIT frequency in 10Hz units.

⑰ **Meter**

When receiving (in other than FM mode), displays the S meter (S). When receiving in FM mode, the meter shows either the S meter (S) or the center meter, as selected using the meter switch ⑱.

When transmitting, metering is switched using the meter switch ⑱ to show the transmission final stage drain current (ID), the transmission power (Po), SWR, automatic level control (ALC) or compression level (COMP).

⑩ **ANT (antenna) display**

Shows which antenna is currently in use.

⑪ **FILTER display**

Shows the filter currently in use.

⑫ **MODE display**

Shows the current mode.

⑬ **AGC display**

Shows the reception AGC time constant.

⑭ **XMIT (transmit) display**

Lights when transmitting.

⑮ **SCAN display**

Lights during the scanning operation.

⑯ **REMOTE display**

Lights when the transceiver is remotely controlled from a PC, etc., via the RS-232C port.

⑰ **PAGE (pager) display**

Lights when the pager function is ON in FM mode.

⑱ **RPT (repeater) display**

Lights when repeater operation is specified in FM mode by pressing the SHIFT/REV switch.

⑲ **CSQ (code squelch) display**

Lights when the code squelch function is ON in FM mode.

⑳ **TSQ (tone squelch) display**

Lights when the tone squelch function is ON in FM mode.

㉑ **FBK (full break-in) display**

Lights when, in CW mode, full break-in (transmitting with the key down, receiving with the key up with no delay time) is selected.

㉒ **SBK (semi break-in) display**

Lights when semi break-in is selected in CW mode.

㉓ **REVERSE display**

Lights when, in CW mode or AFSK mode, the SHIFT/REV key ⑲ is pressed to reverse the carrier point or mark/space.

㉔ **FUNCTION display**

Lights when the keypad key ⑲ is in function mode.

4.2 Front Panel (Part 2)

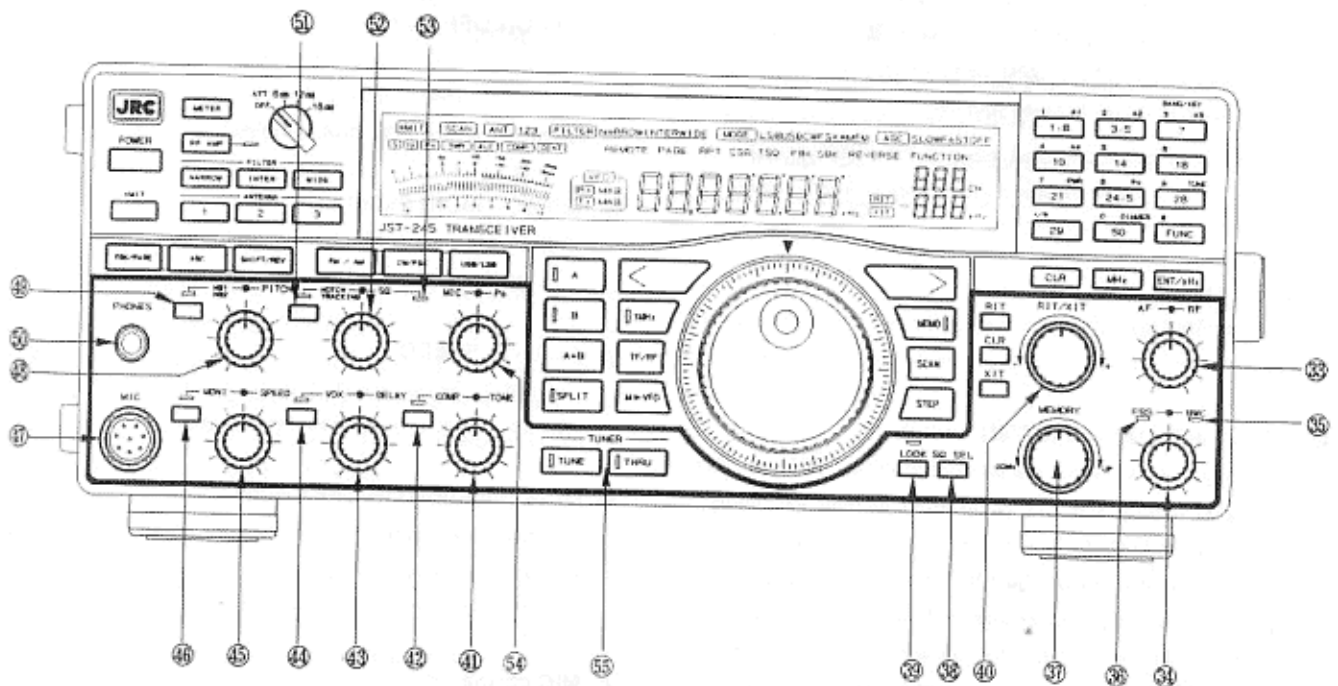

Figure 4.2 Front Panel (Part 2)

③ (inner) **AF (AF gain)**

The inner knob adjusts the AF gain. Rotating this knob changes the audio amplifier gain to adjust the volume.

④ (outer) **RF (RF gain)**

The outer ring adjusts the RF gain. Rotating this ring in other than FM mode changes the receiver's 1st IF, 2nd IF, and 3rd IF gain. Rotate fully clockwise for maximum gain. As you rotate counterclockwise from full gain, gain is decreased and the S meter starts moving.

For normal use, rotate the RF gain fully clockwise.

⑦ (inner) **PBS (pass band shift)**

The inner knob adjusts the pass band shift. Adjust the PBS when there is interference from a neighboring frequency. Rotating the PBS knob varies the apparent center frequency of the IF filter in 10Hz steps.

The PBS does not function when the PBS knob is centered.

NOTE

Using the PBS may distort the received sound. The PBS knob should therefore be rotated until it clicks into its central position when you are not using the PBS.

⑤ (outer) **BWC (bandwidth control)**

The outer ring is used for bandwidth control. This control continuously adjusts the effective bandwidth of the receiver's IF to prevent interference.

The BWC should normally be OFF (fully counter clockwise).

⑥ **BWC (bandwidth control) LED**

Lights when bandwidth control is ON.

⑧ **PBS (pass-band shift) LED**

Lights when the pass band shift is ON.

⑨ **MEMORY**

Selects a memory channel.

⑳ **SQ SEL (squelch selector) switch**

Selects the squelch method when in FM mode. There are three types of squelch in FM mode: noise squelch, tone squelch (optional), and code squelch (optional). Press SQ SEL to select tone squelch, which lights the TSQ lamp ㉓. Press again to select code squelch, which lights the CSQ lamp ㉔.

Press again to return to noise squelch.

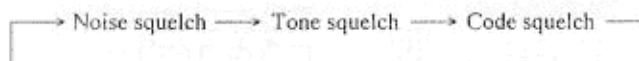

㉑ **LOCK switch**

Electrically locks the main tuning control. Press this switch to prevent the frequency from being inadvertently changed.

㉒ **RIT/XIT adjuster and RIT/XIT switch**

This adjuster and switch are for controlling the RIT (receiver incremental tuning) and XIT (transmitter incremental tuning). Press to lock in both the RIT and XIT switches, then rotate the adjuster to simultaneously adjust the transmitting and receiving frequencies. The frequency change is shown on the display ㉕. Press the **CLR** key to clear the RIT and XIT settings. When only the **RIT** key is pressed, the reception frequency is altered up/down by up to 10kHz. The degree of change is displayed by ㉖ on the LCD in 10Hz units.

Similarly, when only the **XIT** key is pressed, the transmission frequency is altered up/down by up to 10kHz. The degree of change is also displayed on the LCD.

㉓ **(inner) COMP (compressor)**

Adjusts the compression of fluctuations in the audio level to increase talking power. Rotate COMP clockwise to increase compression. However, this results in a slightly deteriorated sound quality. Note also that, the greater the degree of compression, the greater the risk of noise being picked up from around the microphone.

㉔ **(outer) TONE control**

Adjusts the tone of received sound. Rotate TONE clockwise to increase bass, or counterclockwise to cut bass and increase treble. The central position is for flat tone.

㉕ **COMP (compressor) switch**

Turns the speech compressor on and off.

The LED lights when speech compression is ON.

㉖ **(inner) VOX**

Adjusts the VOX amp gain. Rotate clockwise so that VOX picks up smaller vocal sounds, allowing them to be transmitted.

㉗ **(outer) DELAY**

Adjusts the transmission delay when using VOX. Rotate clockwise to increase the delay.

㉘ **VOX ON/OFF switch**

Switches VOX on and off. The LED lights when VOX is ON. In CW mode, pressing the VOX ON/OFF switch selects semi break-in. The SBK display lights.

㉙ **(inner) MONI (monitor)**

Adjusts the volume of the transmission IF monitor (optional). In CW mode, this knob adjusts the side tone volume.

㉚ **(outer) SPEED**

Adjusts the keying speed of the built-in electric keyer.

Rotate clockwise to increase keying speed.

㉛ **MONI (monitor) ON/OFF switch**

Switches the transmission IF monitor on and off. The LED lights when the monitor is ON.

In FM mode, the monitor does not function.

㉜ **MIC connector**

Connect a microphone to this connector.

㉝ **(inner) NB (noise blanker)**

Adjusts noise blanker sensitivity. Rotate clockwise to increase sensitivity. However, if sensitivity is too high, the blanker may blank the target signal, deteriorating sound quality.

㉞ **(outer) PITCH**

Adjusts the BFO pitch when receiving in CW mode. When receiving a signal at the center of the IF filter, the pitch is about 800Hz when the PITCH ring is in the center. Use the PITCH ring to select the desired pitch.

Changing the setting of the PITCH ring also changes the side tone frequency.

㉟ **NB (noise blanker) switch**

Toggles rotates among OFF, NB1, and NB2. NB1 is effective for narrow pulse noises such as ignition. NB2 is best for wider noises.

㊱ **PHONES (headphones) connector**

Connect headphones to this connector.

When using headphones, internal and external speakers are disconnected.

⑤ NOTCH filter switch

Switches the notch filter and notch tracking on and off. Press to turn ON the notch filter and light the green LED. Press again to turn ON notch tracking and light the red LED. Press once more to turn OFF the notch filter and notch tracking, and turn off the LEDs.

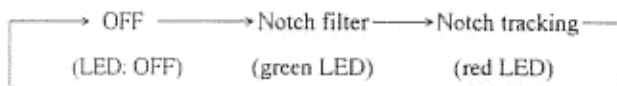

⑥ (inner) NOTCH

The inner knob adjusts the notch filter frequency. Rotate NOTCH to minimize monotone interference from a continuous carrier or CW signal. Now press the NOTCH filter switch ⑤ to start notch tracking; the notch filter will follow within a range of $\pm 10\text{kHz}$ even if the main tuning control is adjusted, thereby continuing to suppress the interference.

⑦ (outer) SQ (squelch)

The outer ring adjusts the squelch threshold level. Rotate SQ clockwise to increase the threshold, requiring a stronger signal to squelch. Rotate SQ fully counterclockwise to set the threshold to the minimum level; sound will be heard from the speaker under all conditions.

⑧ SQ (squelch) LED

Lights when the squelch is closed.

No sound will be heard when the squelch is closed.

NOTE

The squelch does not function when the AGC is OFF (except in FM mode).

⑨ (inner) MIC gain

Adjusts microphone gain. Rotate clockwise to increase the gain.

In SSB and AM modes, adjust the MIC gain until the ALC meter flutters.

In FM mode, set the MIC gain to or below the center position.

⑩ (outer) Po (power) control

Adjusts the transmitter output power. At full clockwise position, the transmitter output will be at rated power.

⑪ TUNER (antenna tuner) switch

Controls operation of the automatic antenna tuner. Press the **TUNE** key to start tuning. The key LED blinks. The LED

lights continuously when tuning is complete. This switch also starts tuning when the optional NFG-230 antenna tuner is installed. When using the built-in tuner, the green LED lights. When using an external tuner, the red LED lights.

Press the **THRU** key to adjust the built-in antenna tuner to the equivalent of a $50\ \Omega$ load, bypassing the external tuner (by direct connection to the antenna).

The **THRU** key does not function on the standard JST-145, which is not equipped with an antenna tuner.

4.3 The Numeric Keypad

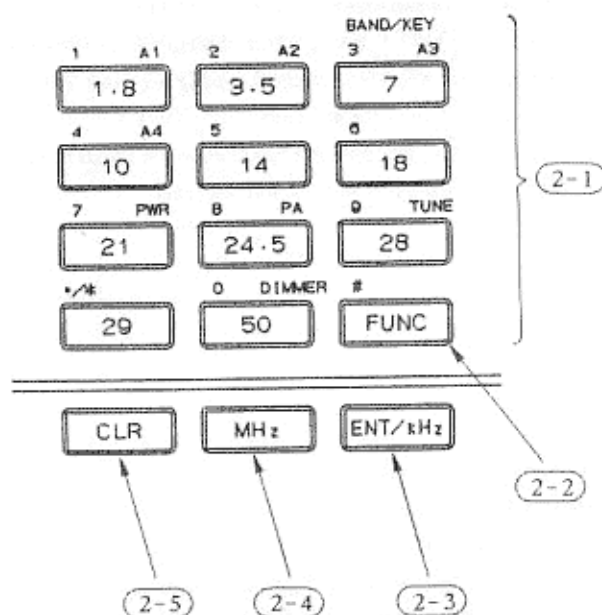

Figure 4.3 The Numeric Keypad

- 2-1** Normally functions as the band selector. Press a key to immediately select the band printed on the key face. These keys can be switched to function as frequency or function keys.

Pressing a band key recalls the last settings (frequency, mode, IF filter, AGC, etc.) used in that band. Further, when moving from one band to another, the current settings are stored in band memory. However, the band's edge frequency is selected if you move bands after selecting a frequency outside the amateur band, then return to the last band. Note that the band keys are inoperative while transmitting.

- 2-2** FUNCTION keys

Changes the keypad keys to function keys. Press the FUNCTION key to light the FUNCTION lamp. Pressing any key with a set function turns OFF the FUNCTION lamp.

1 A1
FUNC 1.8

Selects the 1st antenna connected to linear amplifier JRL-2000F.

2 A2
FUNC 3.5

Selects the 2nd antenna connected to linear amplifier JRL-2000F.

3 A3
FUNC 7

Selects the 3rd antenna connected to linear amplifier JRL-2000F.

4 A4
FUNC 10

Selects the 4th antenna connected to linear amplifier JRL-2000F.

7 PWR
FUNC 21

Turns ON/OFF the power supply of linear amplifier JRL-2000F.

8 PA
FUNC 24.5

Turns ON/OFF the PA of linear amplifier JRL-2000F.

9 TUNE
FUNC 28

Instructs the tuner of linear amplifier JRL-2000F to start tuning operations.

0 DIMMER
FUNC 50

Dims display brightness.

- 2-3** ENT/kHz (Enter/kHz) key

Directly inputs a frequency.

Example: Press the following keys to specify a frequency of 14,225.3kHz.

ENT/kHz 1 A1 4 A4 2 A2 2 A2 5 /* 29
7 ENT/kHz

- 2-4** MHz key

Allows frequencies to be input in MHz.

Example: Press the following keys to specify a frequency of 14.2253MHz.

ENT/kHz 1 A1 4 A4 /* 29 2 A2 2 A2 5
7 MHz

- 2-5** CLR (clear) key

Clears a key entry. Note, however, that you cannot clear an entry after pressing the ENT/kHz or MHz key after specifying a frequency.

4.4 Frequency Controls

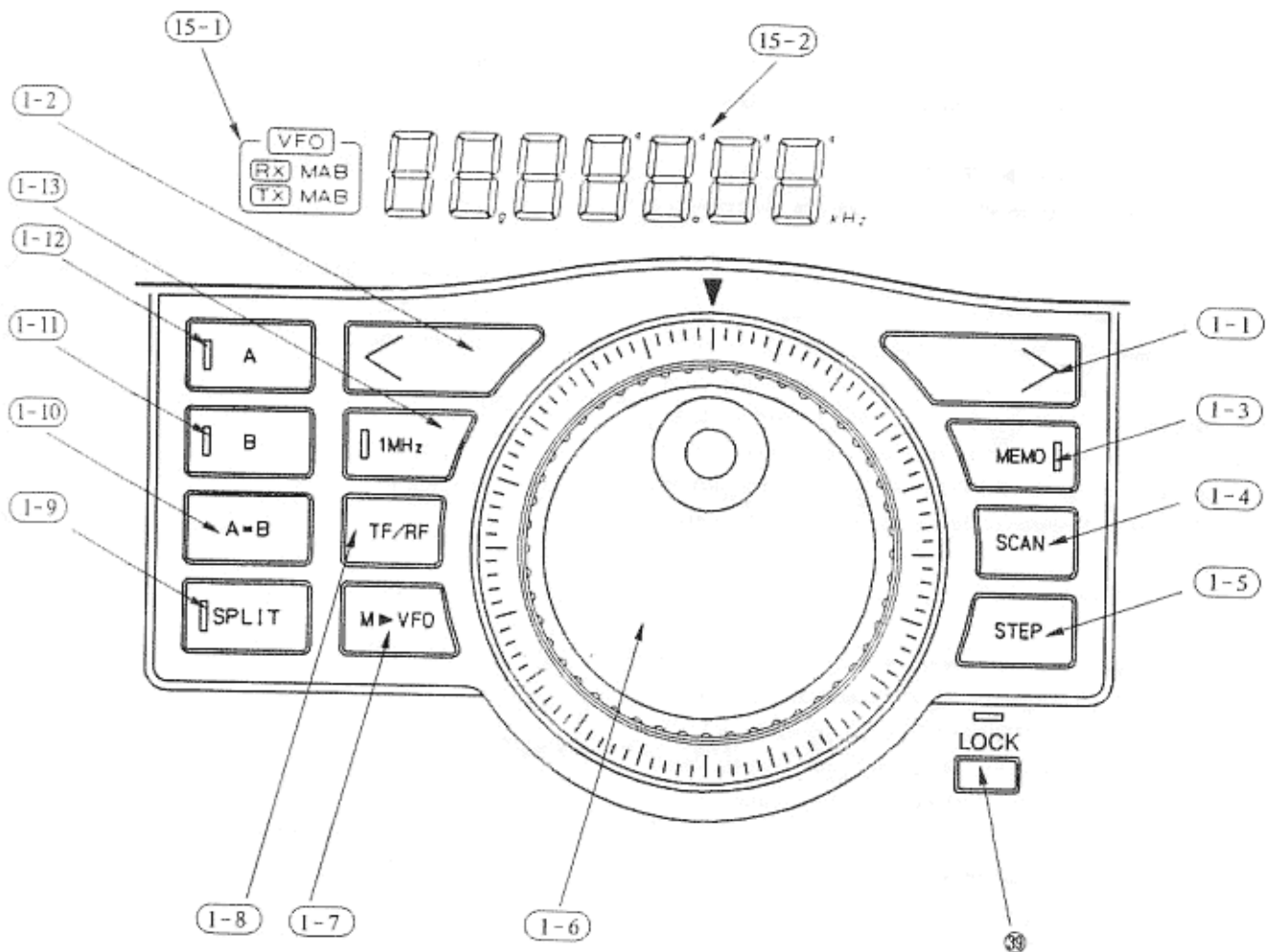

Figure 4.4 Frequency Controls

1-1 > Up key (**1-2** Down key)

Press the up (>) key to continuously increase the displayed frequency. Similarly, press the down (<) key to continuously decrease the displayed frequency. Press the 1MHz key **1-3** then the up (>) or down (<) key to increase or decrease frequencies in 1MHz steps.

1-3 MEMO (memory) key

Recalls settings from memory. The LED lights when stored settings are recalled.

Pressing the MEMO key in VFO mode displays a previously called memory channel number on the memory channel display **16** and simultaneously changes mode, frequency, and IF filter settings, etc., according to the contents of memory. Use the memory selector **17** to change

memory channels.

See 6.1 for details of using memory.

1-4 SCAN key

Starts or stops scanning. The SCAN lamp **18** lights during the scanning operation.

See 6.6 for details of using the scan function.

1-5 STEP key

Changes the frequencies changed per step when using the main tuning control.

There are two steps, 10Hz and 100Hz.

The currently selected step is indicated by the marks to the top right of the numbers on the frequency display.

You can also define an additional 1kHz step in FM mode

and 2Hz step in other modes.

1-6 Main tuning control

Changes the frequency by 2,000 frequency steps per rotation.

Use the STEP key **1-5** to select 10Hz or 100Hz steps.

1-7 M ► VFO (memory ► VFO) key

Sends information recalled from memory to the currently selected VFO.

1-8 TF/RF (transmission frequency/reception frequency) key

Monitors the frequencies of the unused VFO. For example, if you are using A-VFO for receiving or transmitting, press and hold the TF/RF key to display the frequency of the unused VFO (B-VFO). You can now use the main tuning control to change the B-VFO frequency. The transmission and reception frequencies do not change during this operation.

1-9 SPLIT key

Selects split operation between A-VFO and B-VFO. The SPLIT key's LED lights during split operation. When SPLIT is ON, the selected VFO (the VFO indicated by the lit LED) is used for reception. The VFO display **15-1** shows which VFO is used for reception and which for transmission.

1-10 A = B (VFO equalization) key

Transfers the settings of the VFO currently in use to the other VFO.

As a result, both A-VFO and B-VFO have the same settings.

1-11 B-VFO selector

Selects simplex operation using B-VFO

1-12 A-VFO selector

Selects simplex operation using A-VFO

1-13 1MHz key

Sets the up (>) and down (<) keys to a 1MHz step.

15-1 VFO display

Shows whether A-VFO, B-VFO, or memory is used for receiving or transmitting.

Reception: Memory Transmission: Memory

VFO

RXM

TXM

Reception: B-VFO Transmission: A-VFO

VFO

RX—B

TX—A—

15-2 Smallest digit mark

Indicates the smallest digit that changes when using the main tuning control.

When not lit, the step is 2Hz.

4.5 Rear Panel

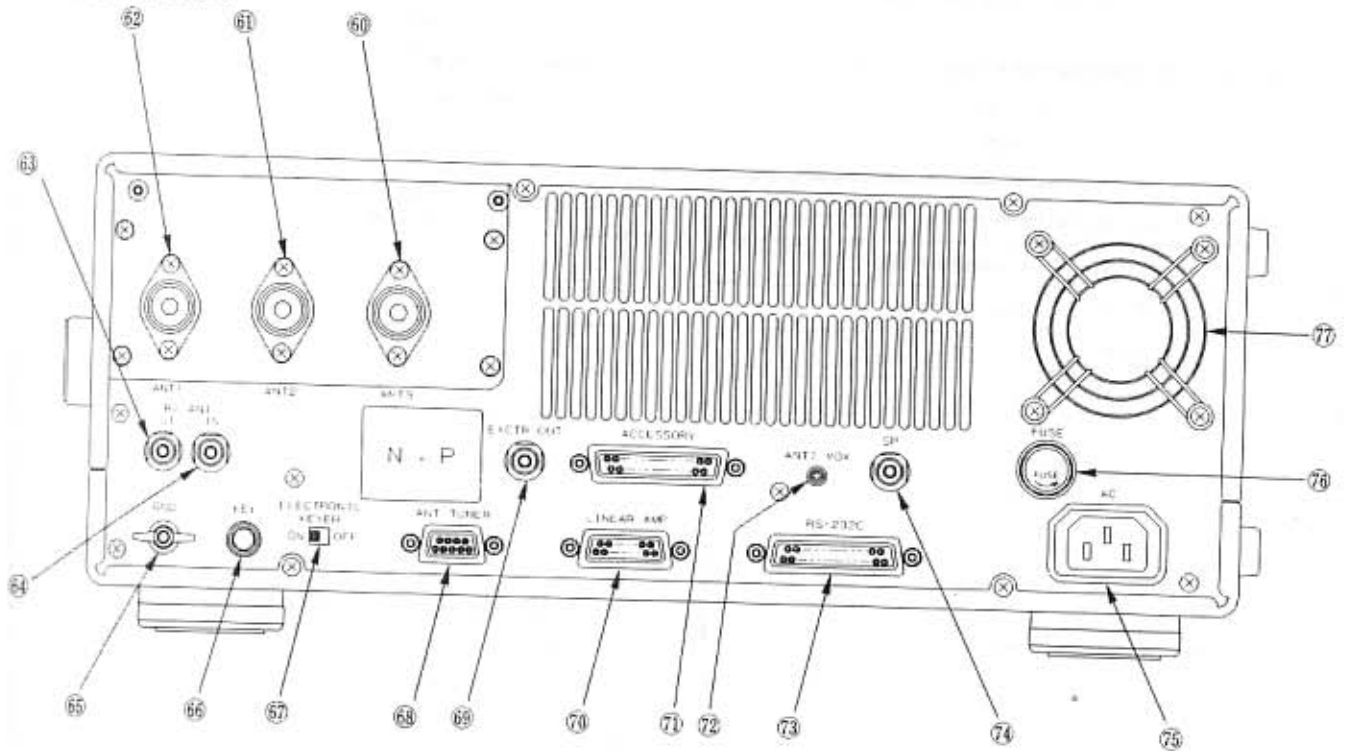

Figure 4.5 Rear Panel

50, 51, 52 ANT (antenna) connectors

Used for connection to 50 Ω antennas with UHF-type plugs.

53 RX ANT OUT (receiving antenna output)

Connected to 50, 51 or 52 when the set is receiving. Use this connector to connect another receiver.

54 RX ANT IN (receiving antenna input)

When using a receive-only antenna, connect it to this connector.

55 GND (ground)

Used for connection to an earth ground system. Use a short, thick copper wire as required.

56 KEY connector

For connecting a Morse key or manipulator.

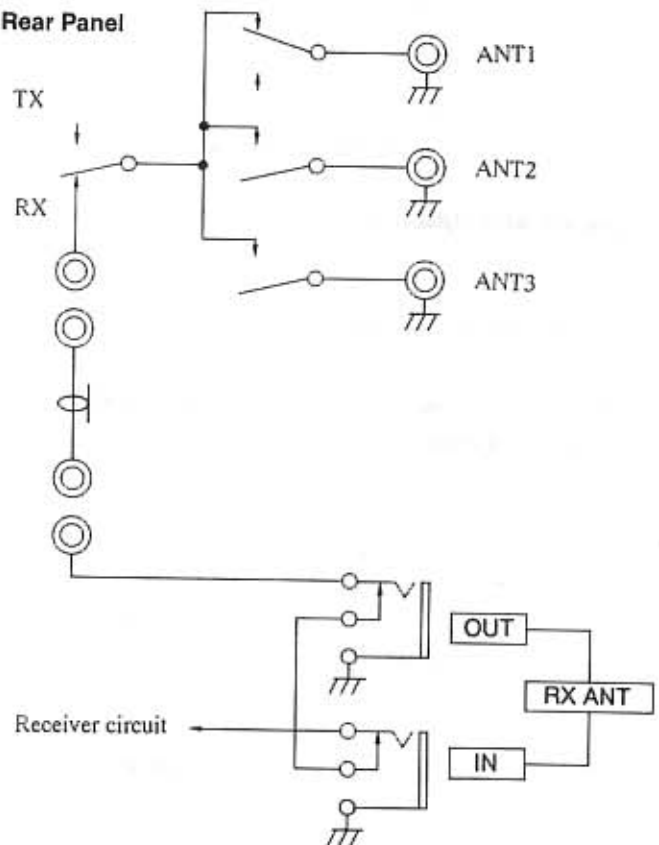

Figure 4.6 Internal Connection of Antenna Connectors

⑥7 **ELECTRONIC KEYER ON/OFF switch**

Switches the internal electronic keyer on and off.

⑥8 **ANT TUNER (antenna tuner) connector**

For connecting the control cable of the optional external NFG-230 antenna tuner.

Pin No.	Signal Nomenclature	Function
1	SHLD	Ground (shield)
2	ETD	Bus line output
3	ERD	Bus line input
4	IA	Antenna current sensor input
5	—	—
6	13.8V	13.8V output
7	13.8V	13.8V output
8	E	Ground
9	E	Ground

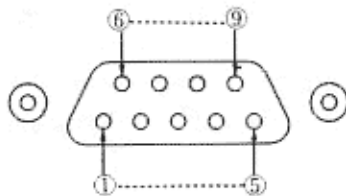

(Pin configuration from the rear panel)

Figure 4.7 ANT TUNER Connector Pin Configuration

⑥9 **EXCTR OUT (exciter output)**

For connecting transmission output when using a transverter, etc. The connector has a 50 Ω impedance and a maximum output voltage of 1Vrms.

⑦0 **LINEAR AMP connector**

Used to connect a linear amplifier.

See 6.17.2 for details of how to connect a linear amplifier.

Use the supplied 15-pin plug or a commercially-available 15-pin D-sub plug.

Use JRC's CFQ-4794 cable to connect the JRL-2000F.

Pin No.	Signal Nomenclature	Function
1	E	Ground
2	TXD	Bus line output
3	RXD	Bus line input
4	—	—
5	ALC	ALC input
6	\overline{RL}	Should be grounded for operating a linear amp.
7	LACM	Standby relay contact output (common)
8	LAMK	Standby relay contact output (make)
9	E	Ground
10	—	—
11	—	—
12	TX13.8V	Transmitting: 13.8V output
13	E	Ground
14	13.8V	13.8 output
15	E	Ground

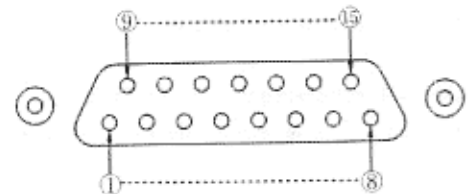

(Pin configuration from the rear panel)

Figure 4.8 LINEAR AMP Connector Pin Configuration

⑩ ACCESSORY connector

Various outputs, and inputs for control signals when using external devices.

Use the 25-pin plug supplied or a commercially-available 25-pin D-sub plug.

Pin No.	Signal Nomenclature	Function
1	- BK	Standby input/output
2	RXBK	Muting input for the receiver
3	SEL BK	During grounded, the transmitter is set to transmission in AM mode.
4	—	—
5	E	Ground
6	XVT	Externally switches from transmitter output to transverter output
7, 8	—	—
9	LINE OUT	Reception line output (0dBm: 600 Ω) (squelch not operative on this output)
10	E	Ground
11, 12	—	—
13	MIC MUTE	Applying a voltage of 5 to 13.8V mutes from signals microphone for transmitting. LINE IN is not muted.
14	13.8V	13.8V output Maximum current: 50mA
15	E	Ground
16	LINE IN	External transmission modulation input (-40dBm)
17, 18	—	—
19	BUSY	"L" when squelch is closed. Maximum current: 10mA
20	—	—
21	—	—
22 - 24	—	—
25	E	Ground

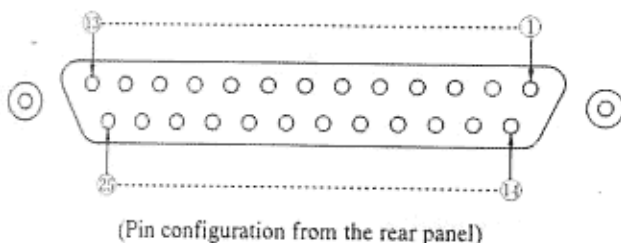

Figure 4.9 Accessory Connector Pin Configuration

⑪ ANTI VOX adjuster

When in VOX operation, set to the optimum position to prevent incorrect VOX operation due to sound from the speaker.

⑫ RS-232C Interface connector

For connecting a PC, etc., for remote control.

Pin No.	Signal Nomenclature	Function
1	FG	Ground
2	SD	Send data
3	RD	Receive data
4	RS	Request to send
5	CS	Not used
6	—	—
7	SG	Ground
8	—	—
⋮	—	—
25	—	—

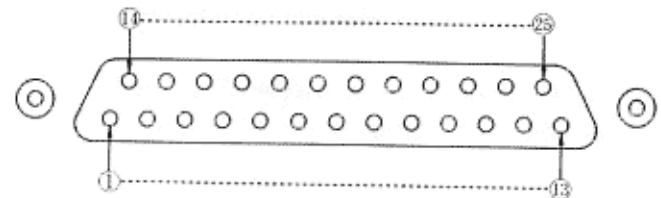

(Pin configuration from the rear panel)

Figure 4.10 RS-232C Connector Pin Configuration

⑬ SP (external speaker) connector

For connecting an optional external speaker.

⑭ AC connector

For connecting the supplied AC cable.

⑮ FUSE

The JST-145/245 uses a cartridge fuse. Be sure to replace with a fuse of the specified capacity.

⑯ Power supply fan

For cooling the power supply.

Section 5. Basic Operation

This section describes the basic operation of the JST-145/245. See Section 4, "Operating Controls" for details of switches and other controls.

5.1 Preliminary Settings

- After connecting the power cable, antenna, and earth, etc., as indicated in Section 3, keep the **POWER** switch OFF and set the various controls as shown in Table 5.1

Table 5.1 Preliminary Settings

AF gain control ⑬ (inner):	Fully counterclockwise
RF gain control ⑭ (outer):	Fully clockwise
ATT switch ⑮:	OFF
PITCH control ⑯ (outer):	Center
SQ (squelch) control ⑰ (outer):	Fully counterclockwise
MIC control ⑱ (inner):	Center
Po (power) control ⑲ (outer):	Fully clockwise
TONE control ⑳:	Center

- Turn ON the POWER switch ⑥ and check that the frequency, etc., is shown on the display.

CAUTION

Do not attempt to transmit without an antenna or dummy load connected to the antenna connector on the back of the JST-145/245.

5.2 Frequency Setting

There are four methods of setting frequencies.

(1) Band/key switches and main tuning control

For example, to set 7.085MHz, perform the following operations:

- Press **7** on the band keys **2-1**.
- Slowly rotate the main tuning control **1-6** to set the 100kHz, 10kHz, and 1kHz digits to 0, 8, and 5.

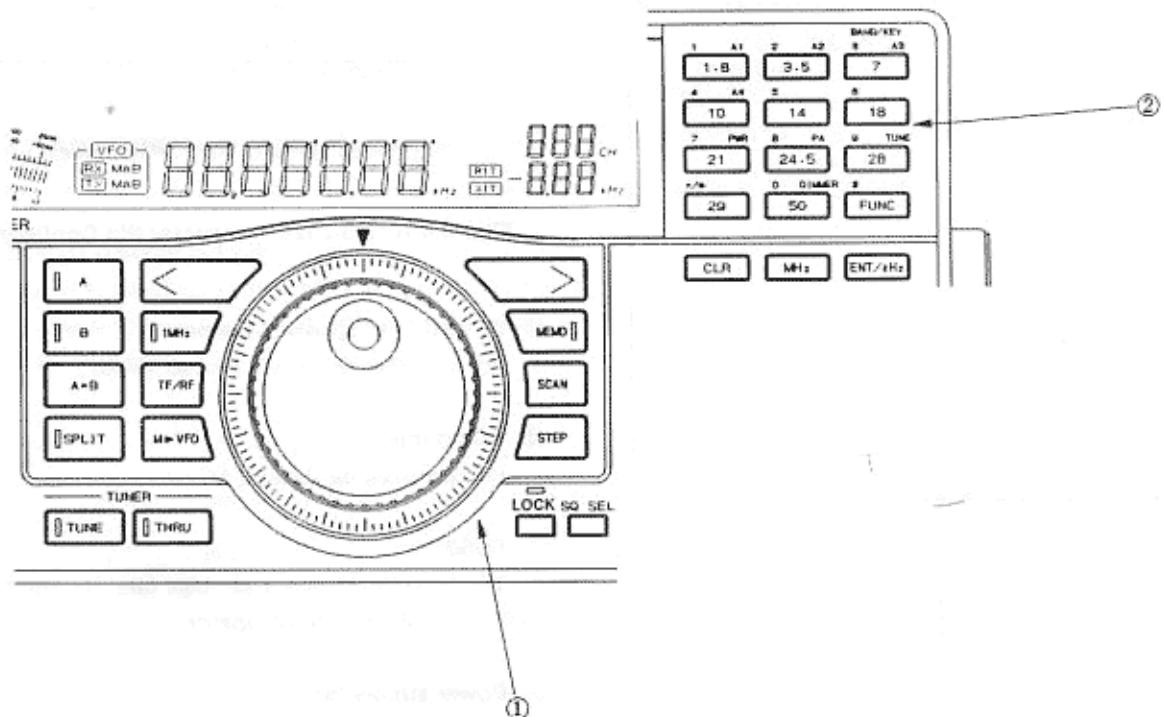

Figure 5.1 Keypad Keys and Main Tuning Control

(2) < > keys and tuning control

In this example, we also set 7.085MHz.

- 1) Press the **1MHz** key (1-13). (The LED lights.)
- 2) Set the MHz digit to 7 using the **>** key (1-1) and **<** key (1-2).
- 3) Set digits up to 100kHz using the main tuning control.

(3) Keypad keys

The numbers and marks to the top left of the key pad keys (2-1) indicate the respective digits.

- 1) Operate the following keys in the sequence specified to input a value in kHz.

ENT/kHz **7** **PWR** **0** **DIMMER** **8** **PA** **5**
21 **50** **24.5** **14** **ENT/kHz**

- 2) Operate the following keys in the sequence specified to input a value in MHz.

ENT/kHz **7** **PWR** **0** **DIMMER** **8** **PA** **5**
21 **29** **50** **24.5** **14** **MHz**

If you make a mistake, press the **CLR** key (2-5) and start again. Note that you cannot press **CLR** to correct a mistake after pressing the **ENT/kHz** key (2-3) or the **MHz** key (2-4).

(4) Memory

See section 6.1.

5.3 Operation in SSB Mode

Set the controls and switches as indicated below. Keep the remaining controls set as indicated in Section 5.1.

SSB Mode Settings

- Frequency: Set to the desired SSB frequency in the selected band
- MODE switch (1) (right): LSB or USB (LSB in the 7MHz or lower amateur bands)
- FILTER switch (7): INTER or WIDE
- AGC switch (13): SLOW
- AF gain control (3) (inner): Set to the desired volume.

In SSB mode, the carrier frequency is shown on the display.

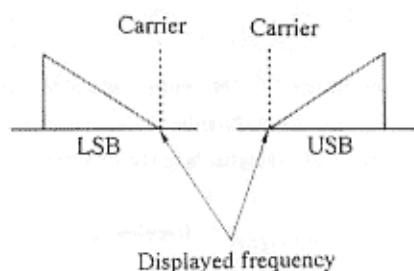

Figure 5.2 Frequency Display in SSB Mode

5.3.1 Receiving

Slowly rotate the tuning control until the SSB signal is received clearly. Rotate the RF gain slightly counterclockwise if noise is a problem during gaps in speech.

5.3.2 Transmitting

CAUTION

Use a dummy load in place of the antenna for transmission tests. Also, before starting transmission, try receiving on the same frequency that you will use for the transmission to check if the frequency is not used.

- 1) Press the **TUNE** key (5) and wait for the LED to stop blinking and light continuously (JST-245, or JST-145 with optional internal tuner installed).
- 2) Press the **XMIT** switch (5) or the PTT switch on the microphone. Then the XMIT display (2) turns ON.
- 3) Use the **METER** switch (3) to display the Po (power), then start talking toward the microphone. Then the Po meter deflects with speech.
- 4) Switch back to ALC metering and adjust the MIC control (4) (inner) so that the meter deflects intermittently.
- 5) Press the **XMIT** switch (5) again or release the PTT switch to return to receive mode.

5.4 Operation in CW Mode

Set the controls and switches as indicated below. Keep the remaining controls set as indicated in Section 5.1.

CW Mode Settings

- Frequency: Set to the desired CW frequency in the selected band
- MODE switch (1) (inner): CW
- FILTER switch (7) (right): WIDE
- AGC switch (13): FAST

AF gain control ⑬ (inner): Set to the desired volume.

In CW mode, if the PITCH control ⑭ (outer) is set to the center position, the demodulation audio frequency is about 800Hz when the received signal is at the IF filter center.

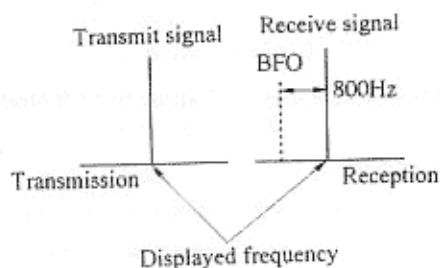

Figure 5.3 Frequency Display in CW Mode

5.4.1 Receiving

- 1) Slowly rotate the tuning control ①-⑥ until the CW signal is received clearly.
- 2) If the signal is too strong, try slowly reducing the RF gain using the RF gain control ⑮ (outer). This should further improve reception.

NOTE

INTER and **NARROW** positions on the **FILTER** switch ⑦ are only operative when the optional CW filter are installed.

5.4.2 Transmitting

- 1) Press the **TUNE** key ⑫ (left) and wait for the LED to stop blinking and light continuously (JST-245, or JST-145 with optional internal tuner installed).
- 2) Press the **XMIT** switch ⑤.
- 3) Set the **METER** switch ③ to Po (power).
- 4) Key down causes the power meter to deflect and a CW signal to be output. You can also monitor the keying signal using the side tone.
- 5) Release the key and press the **XMIT** switch ⑤ to return to the receiving mode.

See section 6.10 on break-in operations for semi break-in and full break-in operations.

5.5 Operation in AM Mode

Set the controls and switches as indicated below. Keep the remaining controls set as indicated in Section 5.1.

AM Mode Settings

- Frequency: Set to the desired AM frequency in the selected band
- MODE switch ⑩ (left): AM
- FILTER switch ⑦ (center): INTER
- AGC** switch ⑬: SLOW
- AF gain control ⑬ (inner): Set to the desired volume.

In AM mode, the carrier frequency is shown on the display. A3H is used for transmission.

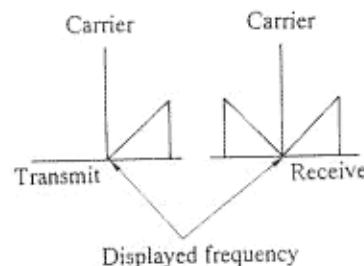

Figure 5.4 Frequency Display in AM Mode

5.5.1 Receiving

- 1) Slowly rotate the tuning control until the S meter deflection is maximum.
- 2) When the signal is reasonably strong, setting the **FILTER** selector to **WIDE** changes the bandwidth to 12kHz, improving sound quality.

5.5.2 Transmitting

- 1) Press the **TUNE** key ⑫ (left) and wait for the LED to stop blinking and light continuously. (JST-245, or JST-145 with optional internal tuner installed)
- 2) Press the **XMIT** switch ⑤ or the PTT switch on the microphone. Check that the XMIT display ② turns ON.
- 3) Use the **METER** switch ③ to display ALC metering.
- 4) Adjust the MIC control ⑭ (inner) until the meter starts to deflect.
- 5) Press the **XMIT** switch ⑤ again or release the PTT switch to return to receive mode.

5.6 Operation in FM Mode

Set the controls and switches as indicated below. Keep the remaining controls set as indicated in Section 5.1.

NOTE

FM can only be used on the 29MHz and 50MHz bands. The frequency range in which the amateur communication is available is also restricted.

FM Mode Settings

Frequency:	Set to the desired FM frequency in the selected band
MODE switch ⑪ (left):	FM (Press once more when AM is displayed)
FILTER switch:	WIDE
AF gain control ⑬ (inner):	Set to the desired volume.

In FM mode, the carrier frequency is shown for both transmitting and receiving.

5.6.1 Receiving

- 1) Slowly rotate the SQ (squelch) control ⑫ (outer) clockwise to cancel noise from the speaker.
- 2) Slowly rotate the tuning control (1-6) to the maximum deflection of the S meter.
- 3) Set the meter switch ③ to the center meter and check that the indicator is near the center. If not, adjust the tuning control so that the indicator is centered.

5.6.2 Transmitting

- 1) Press the **TUNE** key ⑭ (left) and wait for the LED to stop blinking and light continuously. (JST-245, or JST-145 with optional internal tuner installed).
- 2) Press the **XMIT** switch ⑤ or the PTT switch on the microphone.
- 3) Use the **METER** switch ③ to display Po (power) metering.
- 4) Speak at a normal level toward the microphone.
- 5) Press the **XMIT** switch ⑤ again or release the PTT switch to return to the receiving mode.

5.7 Operation in AFSK Mode

To use AFSK mode requires an external modem and a terminal such as a teletypewriter or PC. See section 6.17, "Connecting Peripherals" for details.

AFSK Mode Settings

Frequency:	Set to the desired AFSK frequency in the selected band
MODE switch ⑪ (center):	AFSK (Press once more when CW is displayed.)
FILTER switch ⑦:	WIDE
AF gain control ⑬ (inner):	Set to the desired volume.

In AFSK mode, the mark frequency (for modulation at 2125Hz) is shown for both transmitting and receiving.

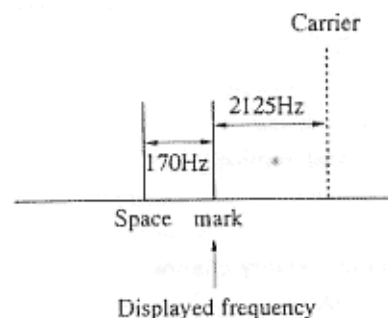

Figure 5.5 Frequency Display in AFSK Mode

5.7.1 Receiving

Slowly rotate the tuning control (1-6) to receive the RTTY signal with a demodulate tone of about 2210Hz. Fine tune while checking the modem indicators.

5.7.2 Transmitting

Transmit as described in the instruction manuals of the external modem and terminal.

5.8 Switching Antenna Connections

The JST-145/245 have three antenna connectors. However, only ANT1 is connected when the unit leaves the factory.

To use ANT2 or ANT3, you must set user definitions No.13 and No.14. Thereafter, you can use the antenna switch ⑨ to select any of the three connectors.

To use antenna tuner NFG-230, you must set user definition No. 11. To use linear amp JRL-2000F, you must set user definition No.12.

See section 6.18 for how to set user definitions.

Section 6. Operation

6.1 Memory Functions

The JST-145/245 has 200 memory channels, which when used well allow efficient QSO. You can also store A and B VFO data for split operations.

1) Information stored in memory channels

Frequency:	From 10MHz to 1Hz digits
Mode:	FM, AM, CW, FSK, LSB, and USB
Filter:	Narrow, Inter, or Wide
AGC:	Slow, Fast, or Off
RF AMP:	On or off
Antenna No.:	No. 1, No. 2, or No. 3
Split ON/OFF:	On or off
Shift information	
Tone squelch information	
Code squelch information	
RF AMP ON/OFF:	On or off

2) Recalling memory channels

Press the **MEMO** key (1-3). The LED lights and the number of the memory channel is shown on the display (9). The reception frequency, etc., are set to the data stored in memory.

Rotating the MEMORY knob (9) changes the memory channel. If you select an empty channel, the memory channel display shows "-----" and the receiver sound turns off.

3) Making changes after recalling data from memory

After recalling data from memory, you can use the tuning control, mode switches, filter switches and other controls to change the frequency, mode, or filter, etc. However, the new settings remain temporary unless stored in memory. See section 6.2.1 for how to change the contents of memory.

4) Returning from memory operation to VFO operation

Press the **MEMO** key (1-3) again. This turns off the LED on the **MEMO** key and restores the previous VFO (A or B) settings.

You can press A-VFO or B-VFO to change the VFO setting.

6.2 Using Memory Channels

6.2.1 Storing Data in Memory

- 1) First, select A-VFO or B-VFO to set the frequency, filter, mode, etc., that you wish to store in memory.
- 2) Press the **FUNC** key (2-2) on the keypad, then press the **MEMO** key (1-3).
The channel number display blinks "1CH". The frequency and other displays show the data currently stored in channel 1.
- 3) Specify the channel number with the memory control (9). The respective displays show the data currently stored in the selected channel.
- 4) To overwrite the current data, press the **ENT/kHz** key (2-3). The new data is displayed and the transceiver returns to VFO mode. (This is the same state as in step 1). If the **ENT/kHz** key is not pressed for 5 seconds, the transceiver automatically returns to its initial state.
- 5) In split mode, the contents of both A-VFO and B-VFO are stored in memory.

6.2.2 Checking the Data in a Memory Channel

- 1) Press the **FUNC** key (2-2), then press the **MEMO** key (1-3). Channel No. 1 blinks and the data in channel 1 is shown on the respective displays. However, the actual transmitting or receiving frequency and other data do not change.
- 2) Rotate the memory knob (9) to change the channel number and display the data in the selected channel. "-----" is displayed if no data has been stored in the memory channel. If split data has been stored, the **SPLIT** key (1-9) LED lights. The A-VFO and B-VFO LEDs remain off. Press and hold the **TF/RF** key (1-8) to display the transmitting frequency.
- 3) Press the **MEMO** key (1-3) to return the transceiver to its state before step 1). If no control is used for 5 seconds in step 2, the transceiver automatically returns to its initial state.

6.2.3 Clearing Data from a Memory Channel

- 1) Press the **FUNC** key (2-2), then press the **MEMO** key (1-3). Channel No. 1 blinks and the data in channel 1 is shown on the respective displays.
- 2) Use the memory knob (9) to select the memory channel to clear.
- 3) Check the content of the specified memory channel, the

press the **CLR** key (2-5). The memory channel is cleared and the transceiver returns to its state before step 1). If no control is used for 5 seconds in step 2, the transceiver automatically returns to its initial state.

6.2.4 Copying the Contents of a Memory Channel to VFO

- 1) Press the **MEMO** key (1-3) to recall the last memory channel and display the stored data.
- 2) Use the memory knob (5) to select the desired memory channel and display the stored data.
- 3) Press the **M ▶ VFO** key (1-7) to copy the data from the memory channel to A-VFO or B-VFO, whichever was selected before pressing the **MEMO** key in step 1). The transceiver returns to VFO mode. The contents of the selected memory channel are preserved. However, the original settings of the VFO cannot be recovered.

Note that you cannot copy to a VFO while transmitting.

- 4) Press the **M ▶ VFO** key (1-7) while the LED of the **SPLIT** key (1-9) is on to copy the receiving frequency to the receiving VFO and the transmitting frequency to the transmitting VFO.

6.3 Simplex Operation

1) Two VFOs

The JST-145/245 has A-VFO and B-VFO, which can be used for simplex or split operation. The settings stored in the VFOs are virtually identical to those stored in memory.

VFO programming

Frequency:	From 10MHz to 1Hz digits
Mode:	FM, AM, CW, FSK, LSB, and USB
Filter:	Narrow, Inter, or Wide
AGC:	Slow, Fast, or Off
Antenna No.:	No. 1, No. 2, or No. 3
RF Amp ON/OFF:	On or off
Shift information	
Reverse ON/OFF:	On or off

2) Selecting the VFO

Press the **A** key (1-12). This lights the LED on the key and sets the frequency, etc., according to the data in A-VFO. The data is shown on the respective displays. Similarly, press the **B** key (1-11) to select the B-VFO.

The stored data for the selected VFO changes each time you use the main tuning control, key pad, FILTER switch, or MODE switch, etc. The new settings are immediately displayed.

You can use the VFO keys for high level operations such

as monitoring a frequency while communicating with another station.

3) VFO equalization

Press the **A=B** key (1-10) to copy the settings of the currently selected VFO to the other VFO.

Sample settings

A VFO: 7.055MHz, MODE USB, AGC SLOW, ANTENNA No. 1, FILTER INTER

B VFO: 10.115MHz, MODE CW, AGC FAST, ANTENNA No. 1, FILTER WIDE

Key control and status of set

- ① Press key **A**.

VFO		
RX	A	
TX	A	7,055.00kHz

Actual transmission and reception frequency: 7.055MHz

MODE: USB
AGC: SLOW
ANTENNA: No. 1
FILTER: INTER

- ② Press key **B**.

VFO		
RX	B	
TX	B	10,115.00kHz

Actual transmission and reception frequency: 10.115MHz

MODE: CW
AGC: FAST
ANTENNA: No. 1
FILTER: WIDE

- ③ Press key **A=B**.

Sets A-VFO to the B-VFO settings

- ④ Press key **A**.

VFO		
RX	A	
TX	A	10,115.00kHz

Actual transmission frequency: 10.115MHz

MODE: CW
AGC: FAST
ANTENNA: No. 1
FILTER: WIDE

6.4 Split Operation

1) Press the **[SPLIT]** key (1-9) to select split operation mode, in which different frequencies are used for transmitting and receiving. If you press **[SPLIT]** while receiving with A-VFO (B-VFO), you can use A-VFO (B-VFO) for receiving and B-VFO (A-VFO) for transmitting.

2) Switching VFO in split mode

Suppose you are using A-VFO for receiving. If you press key **[B]** while receiving, you can use B-VFO for receiving and A-VFO for transmitting.

3) If A-VFO and B-VFO are set to different modes, the transceiver operates in the mode of the VFO being used for receiving.

4) TF/RF key (1-8)

This switch is used to monitor or set the data in the VFO not currently being used.

For example, suppose you are transmitting using A-VFO. If you press and hold the **[TF/RF]** key (1-8), the B-VFO settings are shown on the displays and you can use the tuning control and other controls to change the frequency. However, the frequency you are actually using for transmitting does not change.

The VFO displays (on the "A" and "B" keys) do not change even while you press and hold the **[TF/RF]** key.

If you press the **[TF/RF]** key while receiving on A(B)VFO

Simplex/ split	Displays	Operation
Simplex	B(A)VFO settings	Reception by A(B)VFO
Split	As above	As above

If you press the **[TF/RF]** key while transmitting on A(B)VFO

Simplex/ split	Displays	Operation
Simplex	B(A)VFO settings	Transmission by A(B)VFO
Split	As above	As above

However, when shift is set ON in FM mode, pressing the **[TF/RF]** key (1-8) displays the shifted frequency on the LCD.

5) RIT/XIT operation

Press the **[RIT]** (**[XIT]**) key $\text{\textcircled{0}}$ to light RIT(XIT) on the RIT(XIT) display and allow the receive (transmit) frequency to change by $\pm 9.99\text{kHz}$ using the RIT/XIT control without changing the transmit (receive) frequency. The amount of change in frequency is shown on the RIT(XIT) display. That is, the actual receive (transmit) frequency is the frequency shown on the frequency display plus the frequency shown on the RIT(XIT) display.

Press the **[RIT]** (**[XIT]**) key again to return to the original receive (transmit) frequency. The RIT(XIT) frequency is stored.

The next time you press the **[RIT]** (**[XIT]**) key, the new RIT(XIT) frequency is displayed and the receive (transmit) frequency changes immediately. Pressing the **[CLR]** key to the left of the RIT/XIT knob cancels the stored RIT(XIT) frequency.

When RIT and XIT are both ON, both XIT and RIT change by the same amount.

Example operation and displays

- Receive frequency: 14.1452MHz, transmit frequency: 14.14382MHz Currently receiving
- Press the **[RIT]** key then rotate the RIT/XIT knob to set +5.22kHz.

Frequency display	RIT display	Actual receive frequency	Actual transmit frequency
14,145.20kHz	5.22kHz	14,150.42kHz	14,143.820kHz

- Press the **[RIT]** key (to turn off RIT).

Frequency display	RIT display	Actual receive frequency	Actual transmit frequency
14,145.20kHz	kHz	14,145.20kHz	14,143.820kHz

- Press the **[RIT]** key (to turn on RIT).

Frequency display	RIT display	Actual receive frequency	Actual transmit frequency
14,145.20kHz	5.22kHz	14,150.42kHz	14,143.820kHz

- ⑤ Press the **[XIT]** key, then rotate the RIT/XIT knob to set -4.33kHz.

Frequency display	RIT display	Actual receive frequency	Actual transmit frequency
14,145.20kHz	-4.33kHz	14,140.87kHz	14,139.490kHz

- ⑥ Press the **[CLR]** key.

Frequency display	RIT display	Actual receive frequency	Actual transmit frequency
14,145.20kHz	kHz	14,145.20kHz	14,143.820kHz

6.5 Interference Elimination Functions

6.5.1 Noise Blanker (NB)

A noise blanker is provided to eliminate various types of pulsing noise from the narrow pulsing of ignition systems to the wide pulsing.

The JST-145/245 **[NB]** switch ⑧ has three positions: 1, 2, or OFF. The current setting is indicated by the LED above the switch. Use NB1 (green LED) for combating narrow pulse noise such as automobile ignitions. Use NB2 (red LED) for wide pulse noise.

The NB LEVEL control ⑨ (inner) adjusts the sensitivity of the noise blanker. To increase sensitivity and eliminate low-level noise, rotate the control clockwise. However, too high a sensitivity may cause distortion to the received signal, and the level should therefore be set just high enough to eliminate interference.

NOTE

The blanker may not be effective against some types of noise.

6.5.2 Pass Band Shift (PBS)

The center frequency of the receiving IF filter's passband can be shifted ± 1 kHz without actually changing the receiving frequency. This allows the user to effectively place the filter passband wherever desired, thereby eliminating interference by removing it from the passband.

When the PBS is on, the LED ⑩ close to the PBS control turns on. The PBS ⑪ turns off and the LED ⑫ is extinguished when the PBS control ⑬ (inner) is centered.

In the USB mode, turning the control clockwise from the

center position eliminates interference from the higher frequency component side of a received voice signal. At the same time, the high band portion of the signal is also cut. Conversely, turning the control counterclockwise eliminates interference from the lower frequency component side of the voice signal, while the low band portion of the received signal is cut. In LSB mode, the above relationship is reversed.

NOTE

If the PBS control is set too far from the center position, sound quality of the received signal is degraded. Therefore, always set the PBS control near the center position unless readjustment is necessary.

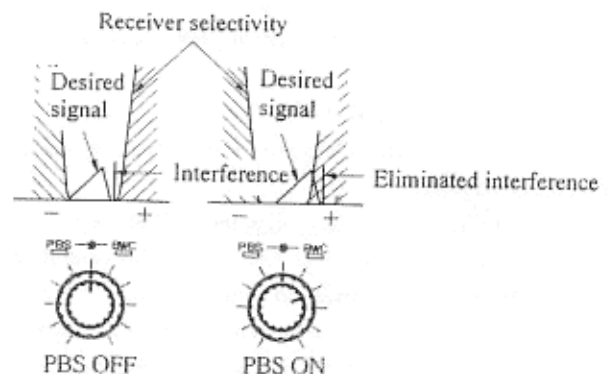

Figure 6.1 Passband Shift (PBS) Operation

6.5.3 Bandwidth Control (BWC)

The BWC combines 9.455MHz and 455kHz filters allowing the apparent width of the passband to be changed and interference eliminated without changing the center frequency of the receiving IF filter.

The pass band width is maximum when the BWC control ⑭ (outer) is rotated fully counterclockwise. It can be narrowed continuously by rotating the knob clockwise. The BWC functions in USB, LSB, CW, AFSK, and AM modes.

The FILTER switch ⑮ selects the combination of 9.455MHz and 455kHz filters. If BWC is implemented with filter combinations in which the characteristics are severely different such as when the BWC is used with wide filters when the JST-145 is operated in SSB mode, the passband frequency characteristics will be degraded with a consequent loss of sound quality. Note that the BWC does not function with filters narrower than 500Hz.

The BWC narrows the passband equally on either side. To narrow the passband on one side only, use the BWC together with the PBS control ⑬ (inner) to select the required band.

NOTE

When not using the BWC, rotate the BWC control ④ (outer) fully counterclockwise.

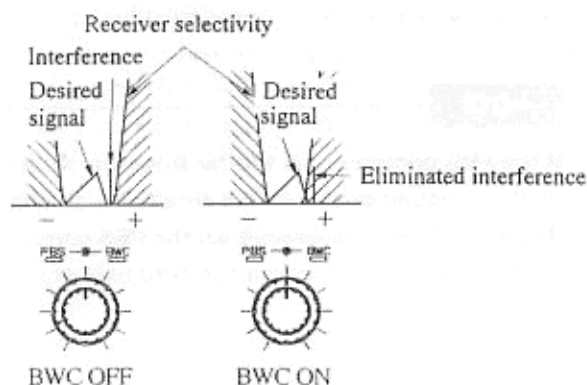

Figure 6.2 Bandwidth Control (BWC) Operation

6.5.4 Notch Filter (NOTCH)

Beat interference from a CW signal or carrier can be eliminated using the notch filter.

Press the **NOTCH** switch ⑤ to light the LED above the switch green and turn on the notch filter. Use the NOTCH control ⑥ to adjust the notch filter frequency and minimize beat.

In LSB or USB mode, beat interference of about 1.5kHz (audio output) is eliminated when the control is in the center position.

Pressing the **NOTCH** switch ⑤ again turns the LED above the switch red and turns on tracking. Pressing the **NOTCH** switch again, turns off the notch filter.

NOTE

Because the notch filter may distort reception, turn the **NOTCH** switch OFF when not required.

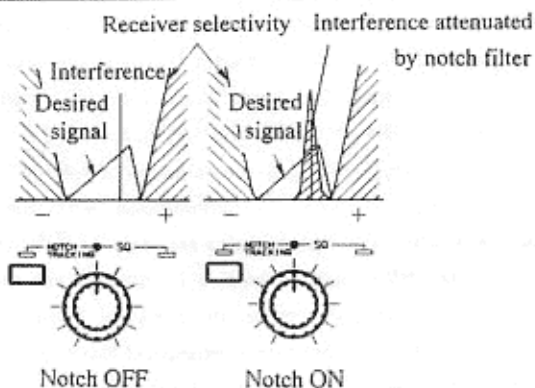

Figure 6.3 Notch Filter (NOTCH) Operation

6.5.5 Notch Tracking Filter (NOTCH TRACKING)

When you adjust the NOTCH control ⑥ (inner) to eliminate beat interference as described in 6.5.4, then turn the tuning control ①-⑥ for fine tuning, the beat interference moves away from the area of attenuation by the notch filter and it is therefore necessary to reset the NOTCH control ⑥ (inner). Pressing the **NOTCH** switch ⑤ a second time when the notch filter is ON (green LED) changes the LED to red and turns on notch tracking, obviating the need to readjust the notch filter.

Once the NOTCH control ⑥ has been adjusted, the notch point tracks the interference even if the receive signal is fine-adjusted using the tuning control ①-⑥. The notch tracking filter tracks up to $\pm 10\text{kHz}$.

NOTE

1. Because the notch filter or notch tracking filter may distort reception, turn off the **NOTCH** switch ⑤ when they are not required.
2. To eliminate different beat interference after the notch tracking filter has been turned on, readjust the NOTCH control ⑥.
3. The notch tracking filter turns off if you recall settings stored in memory when the notch tracking filter is on. If required, turn the notch filter on again.

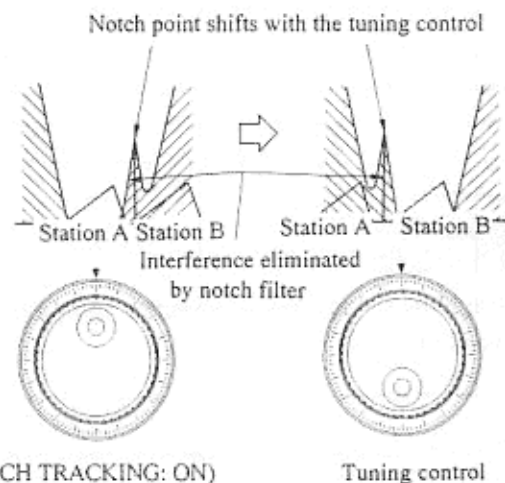

Figure 6.4 Notch Tracking Filter (NOTCH TRACKING) Operation

6.5.6 Reverse (REV)

Reverse reverses the received sound spectrum to produce a less annoying sound when interference is experienced in CW mode.

Pressing the **SHIFT/REV** key (14) reverses the spectrum either side of the center frequency of the IF filter. When the PITCH control is centered, the spectrum is reversed either side of 800Hz. The REVERSE indicator (21) on the LCD lights when reverse is on.

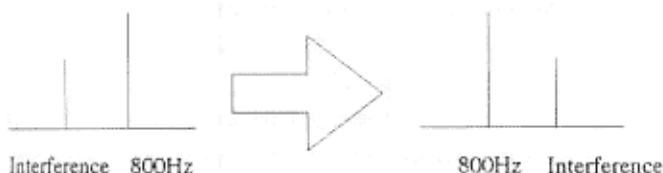

Figure 6.5 Reverse (REV) Operation

6.6 Scanning

The JST-145/245 has three types of scanning reception functions using memory.

Memory scan: Scans all channels in which settings have been stored

Group scan: Scans all channels in a group. Channels are divided into 10 groups (20 channels per group).

Program scan: Sweeps frequencies from the current-VFO frequency to the other-VFO frequency

Use the [RIT] adjuster to adjust the scanning speed during scanning. Ten speeds are available.

6.6.1 Memory Scan

1) Press the **MEMO** key (1-3) to select memory mode. This recalls the last memory channel.

2) Press the **SCAN** key (1-4). The SCAN indicator on the LCD lights and the memory channels are automatically recalled one by one.

You can specify by user definition that scanning pauses when squelch opens. You can also specify that unprogrammed memory channels are skipped. (See 6.18)

3) Press the **SCAN** key (1-4) to pause. Press the **SCAN** key again to continue.

4) Pressing the **CLR** key (2-5) or the PTT switch on the microphone on cancels scanning and returns to normal receive mode. After returning to normal receive mode, transmit mode cannot be selected for two or three seconds after pressing the PTT switch.

6.6.2 Group Scan

1) Press the **MEMO** key (1-3), then press the **SCAN** key (1-4) to start the memory scan.

2) Press the band keys corresponding to the following group numbers.

Group No.	Scanned channels	Band key
1	1 ~ 20	1 A1 1.8
2	21 ~ 40	2 A2 3.5
3	41 ~ 60	3 A3 7
4	61 ~ 80	4 A4 10
5	81 ~ 100	5 14
6	101 ~ 120	6 18
7	121 ~ 140	7 PWR 21
8	141 ~ 160	8 PA 24
9	161 ~ 180	9 TUNE 28
0	181 ~ 200	0 DIMMER 50 (JST-245), 0 DIMMER (JST-145)

3) During scanning, press the **SCAN** key (1-4) to pause. Press the **SCAN** key again to continue.

4) Press the **CLR** key (2-5) or the PTT switch on the microphone on to cancel scanning and return to normal receive mode. After returning to normal receive mode, transmit mode cannot be selected for two or three seconds after pressing the PTT switch.

You can specify by user definition (see 6.18) that scanning pauses when squelch opens. You can also specify that unprogrammed memory channels are skipped.

5) During group scanning, pressing a numeric key (29) changes to memory scanning. After exiting group scanning, pressing the **MEMO** key then pressing the **SCAN** key resumes group scanning.

6.6.3 Program Scan

In program scanning, the set sweeps between frequencies on the currently selected VFO and the other VFO.

1) Press the **A** key (1-12) or **B** key (1-11) to select VFO mode.

2) Press the **SCAN** key (1-4). The SCAN indicator lights and program scanning starts.

3) During scanning, press the **SCAN** key (1-4) to pause. Press the **SCAN** key again to continue.

- 4) Press the **CLR** key (2-5) or the PTT switch on the microphone on to cancel scanning and return to the VFO specified in step 1).

To stop at a selected frequency during scanning, press the **M ▶ VFO** key (1-7). The VFO specified in step 1) is tuned to the new frequency.

6.7 Antenna Tuner Operation

6.7.1 Initial Settings

- 1) The built-in tuner has default data of an LC combination tuned to a 50 Ω load. The tuner is set to 50 Ω when the transceiver leaves the factory.
- 2) When connecting the JRL-2000F linear amp or the NFG-230 wide range external antenna tuner, use the user definition procedure to set the antenna connectors to which they are connected.

See 6.18, "User Definitions" for details.

6.7.2 Tuning Using the Built-in Tuner

- 1) After selecting the frequency and other settings, press the **TUNE** key (left).
- 2) The **TUNE** key LED blinks green, the set automatically changes to CW mode and tuning starts.
- 3) If the SWR drops below 1.2 and tuning stops, the transceiver beeps and the LED stops blinking and lights continuously (green). Data on the LC combination is stored in memory and recalled when the transceiver is subsequently tuned to this frequency, at which time tuning is immediately performed. (This is known as preset tuning.)
- 4) The LED on the **TUNE** key starts blinking again if changes in the ambient conditions of the antenna cause the SWR to rise above 1.5 even after tuning. Press the **TUNE** key to retune the antenna.

If, despite repeated attempts at tuning, the LED on the **TUNE** key does not light continuously, check the feeder cable and antenna.

- 5) If tuning cannot be achieved, the transceiver beeps to indicate an error, the tuning operation is canceled, and the green LED on the **TUNE** key lights. The built-in tuner is automatically set to the state for tuning to a 50 Ω antenna.
- 6) If the **THRU** key (right) is pressed after tuning has finished, the LED on the **TUNE** key turns off and the LED on the **THRU** key changes to green. The built-in tuner is automatically set to the constant for tuning to a 50 Ω antenna.

Pressing the **THRU** key again returns to the tuned state.

NOTE

The SWR meter indicate your antenna's SWR. Therefore, if tuning is perfect, the SWR's indicate de not decrease.

6.7.3 Tuning the NFG-230 External Antenna Tuner

- 1) Connect the NFG-230 and use the user definitions to define the number of the antenna connector.
See section 6.18 for how to set user definitions.
- 2) Press the **TUNE** key (left). The LED above the key blinks red and tuning starts.
- 3) The transceiver beeps and the LED stops blinking and lights continuously when tuning is completed. The preset data is automatically recalled when the transceiver is subsequently tuned to this frequency, at which time tuning is immediately performed.
- 4) Pressing the **THRU** key (left) sets the NFG-230 to the through state. The **TUNE** LED turns off and the LED (red) on the **THRU** key lights.

6.7.4 Tuning the JRL-2000F Linear Amp

The JRL-2000F also has a built-in antenna tuning circuit which can be controlled from the JST-145/245.

- 1) Use the user definition procedure to specify which antenna connector the JRL-2000F is connected to. When you select the antenna connector to which the linear amp is connected, the **TUNE** key and **THRU** key LEDs turn off.
- 2) Press **FUNC** on the key pad, then press **28**. **TUNE** blinks on the frequency display of the JST-145/245. When the JRL-2000F tuner has been tuned, "Good" is displayed on the frequency display of JST-145/245.
- 3) If, for some reason, tuning cannot be completed or commands cannot be exchanged normally between the JST-145/245 and the JRL-2000F, "FAILurE" is displayed. Check the connecting cables, feeder cable and antenna.
- 4) If, when transmitting using the JRL-2000F, the JRL-2000F sensor detects SWR 1.5 or higher, "-2000F-" is displayed on the frequency indicator, showing that retuning is required.

6.8 Voice Operated Transmission (VOX) Operation

The VOX circuit uses sound to automatically switch between transmit and receive modes. To enable VOX in SSB, AM, and FM modes, press the **VOX** key (4). The LED above the **VOX** key lights. Also set VOX on when using semi break-in operations in CW mode.

2) Adjusting VOX delay

The DELAY control ⑬ (outer) adjusts the transmission delay time in VOX operations. As the control is turned clockwise, the delay is increased. Adjust for best VOX operation.

3) ANTI VOX adjustment

Speaker sounds that are picked up by the microphone may trip the VOX circuitry and cause the radio to transmit unintentionally. Adjust the ANTI VOX adjuster ⑭ on the back of your JST-145/245 so that speaker sounds do not trigger the VOX circuitry. ANTI VOX does not function when using headphones.

6.9 Speech Compressor

The speech compressor circuit increases the "talk power" during transmission.

Press the **COMP** key ⑮. The LED above the key lights green.

The COMP control ⑯ (inner) adjusts the input level to the compressor circuit. Rotate the control clockwise to increase the compression to its maximum of about 20dB. However, note that excessive compression degrade sound quality. Also, if you increase the compression, decrease the MIC IN level using the MIC control ⑰ (inner).

The speech compressor can be used in SSB mode. When not in use, turn the **COMP** key ⑮ off (the LED turns off).

6.10 Break-in Operation

The JST-145/245 can operate in full- or semi- break-in in CW mode.

6.10.1 Semi Break-in Operation

In CW mode, press the **VOX** key ⑱ to turn on the SBK ⑲ indicator on the LCD and select semi break-in mode. The LED lights on the **VOX** key.

When the Morse key is pressed, the transceiver automatically transmits and remains in the transmit mode briefly even when the key is released. The delay before returning to receive mode can be adjusted using the DELAY control ⑬ (outer).

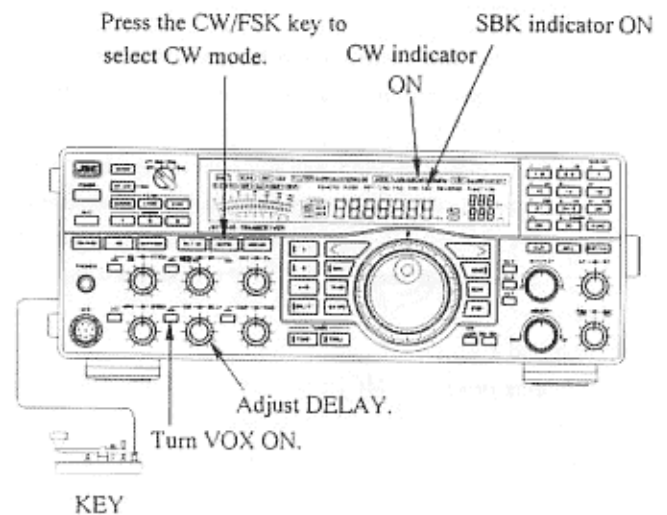

Figure 6.6 Semi Break-In Operation

6.10.2 Full Break-in Operation

In CW mode, press the **FBK/PAGE** key ⑲ to turn on the FBK ⑲ indicator on the LCD (the SBK indicator ⑲ turns off) and select full break-in mode.

When the Morse key is pressed, the transceiver automatically starts transmitting and returns to the receive mode immediately the key is released. Signals can therefore be received between key-up periods.



Figure 6.7 Full Break-In Operation

6.11 Synchronizing Frequency in CW Mode

The JST-145/245's frequency can be adjusted to match that of a received signal by following one of these two procedures:

1) Method 1

Turn off FBK and VOX and press the Morse key. This will key the side-tone oscillator without actually transmitting. Adjust the main tuning control so that the audio frequency of the received signal matches that of the side-tone from the radio.

2) Method 2

Holding down the **METER** switch ③ while in the CW mode will set the BFO to 455 kHz (see Fig. 6.8). This allows zero-beat tuning of the received signal. After zero-beating the received signal, release the METER switch to return to selected BFO offset. This method will work regardless of user-defined BFO pitch, and requires no resetting of the FBK or VOX controls.

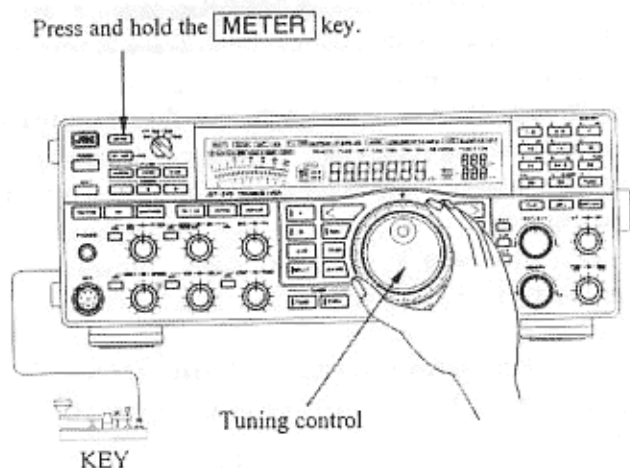

Figure 6.8 CW Zero-in (Method 2)

6.12 Built-in Electric Keyer

The JST-145/245 has a built-in keyer with dot and dash memory. When using this electric keyer, connect a manipulator to the KEY terminal ⑥, then turn on the ELECTRONIC KEYSER ⑦ switch on the rear of the transceiver.

Use the SPEED control ④ (outer) to adjust the keying speed. The speed range is 30 and 150ms of dot.

The ratio between dots and dashes is set when the transceiver leaves the factory to 1:3. However, you can change it to any value between 1:2.5 and 1:4.5 as described in 6.18, "User Definitions".

NOTE

The electric keyer has no message memory function.

6.13 Repeater Operation

In FM mode, the JST-145/245 shift (offset) function can be used for repeater operation. However, you must install the optional CCL-267 tone unit for repeater operations that require tone.

Table 6.1 shows the default shift and tone frequency when the transceiver leaves the factory. The default values can be changed for other repeater specs. See 6.18, "User Definitions" for details.

Table 6.1 Default Shift Settings

Item	Setting	User Definition No.
Direction of shift at transmission	Minus	15
Shift amount at transmission	100kHz	16
Tone	No output	17
Tone system	*CTCSS	18
Tone frequency	*88.5Hz	19

* Valid only with optional CCL-267 tone unit installed.

To use the shift function in FM mode, press the **SHIFT/REV** key ④ so that the RPT indicator ② lights on the LCD then can be use for repeater. Press the PTT switch on the microphone or the **XMIT** switch ⑤ to change to transmit mode. The frequency automatically shifts and is shown on the frequency display ①. If the optional tone unit is installed and a tone has been set, the tone is also automatically added.

To cancel repeater operation, press the **SHIFT/REV** key ④ again.

NOTE

1. The shift (offset) function is available only in FM mode.
2. The transmit frequency does not shift if it will be outside the amateur band after shifting use the shift (offset) function.

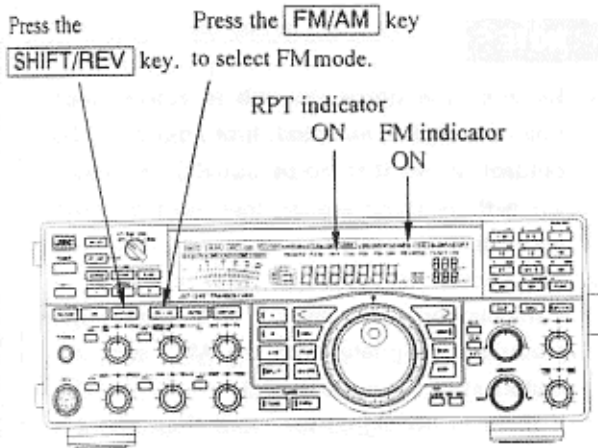





Figure 6.9 Shift Switch for Repeater Operation

6.14 Tone Squelch Operation

Installing the optional CCL-267 tone unit makes it possible for tone squelch (CTCSS: Continuous Tone Coded Squelch System) to be used in FM mode. Squelch opens only when the tone frequency of your and partner stations are the same.

See 6.18, "User Definitions" for details of how to set the tone frequency.

To use the tone squelch function in FM mode, press the **SQ SEL** key . The TSQ indicator on the LCD lights. While squelch is closed, the LED  to the top right of the SQ control  lights, but turns off when a signal with the same tone is received and squelch turns on.

To cancel tone squelch operation, press **SQ SEL**  again. The TSQ and CSQ indicators turn off.

The **SQ SEL** key has a cyclic operation, as follows:

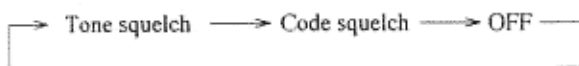

NOTE

During tone squelch operation set the SQ control  (outer) to the position at which the noise squelch is closed when there is no signal.

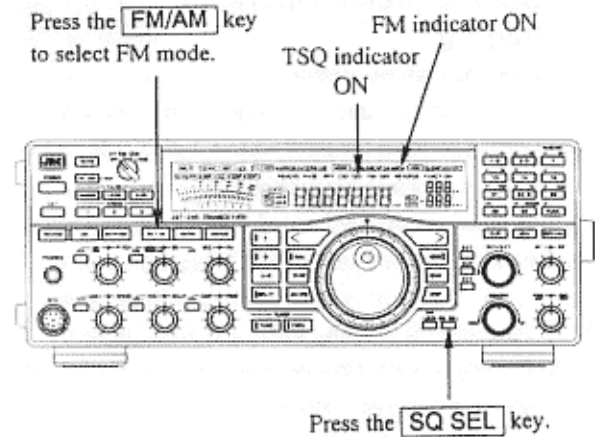

Figure 6.10 Switches and Indicators for Tone Squelch

Table 6.2 Tones

No.	FREQUENCY	No.	FREQUENCY	No.	FREQUENCY
1	67.0 Hz	14	107.2 Hz	27	167.9 Hz
2	71.9	15	110.9	28	173.8
3	74.4	16	114.8	29	179.9
4	77.0	17	118.8	30	186.2
5	79.7	18	123.0	31	192.8
6	82.5	19	127.3	32	203.5
7	85.4	20	131.8	33	210.7
8	88.5	21	136.5	34	218.1
9	91.5	22	141.3	35	225.7
10	94.8	23	146.2	36	233.6
11	97.4	24	151.4	37	241.8
12	100.0	25	156.7	38	250.3
13	103.5	26	162.2		

6.15 Code Squelch Operation and Paging

(1) Code squelch operation



Code squelch uses dual tone multi-frequencies (DTMF) in FM mode. Squelch is triggered when a 3-digit code sent from the partner station matches your station's code.

This function can only be used in FM mode and when the optional CCL-267 tone unit is installed.

1) Programming codes

Before using code squelch, you must program a 3-digit code between 000 and 999 into the transceiver. See 6.18, "User Definitions" for details of how to program the code squelch code.

2) Operation

To use code squelch, select FM mode then press the **SQ SEL** key . The CSQ indicator lights on the LCD and code squelch turns on. While squelch is closed, the LED  to the top right of the SQ control  lights, but turns off when the matching code is received and squelch opens.

To cancel tone squelch operation, press **SQ SEL**  again. The CSQ indicator turns off.

The **SQ SEL** key has a cyclic operation, as follows:

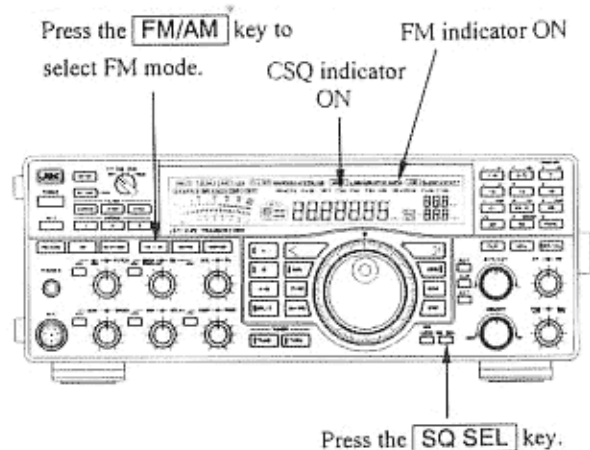
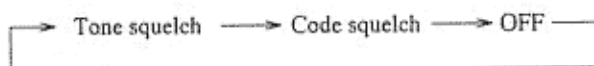



Figure 6.11 Switches and Indicators for Code Squelch

NOTE

1. Because the noise squelch is active when code squelch is selected, first adjust the SQ control  so that noise squelch is closed when there is no signal, then turn on code squelch.
2. The code is sent at the start of a transmission. However, note that the modulation signals from the MIC, etc., are muted while the code is sent.
3. If there is no signal for more than about 2 seconds after code squelch has been triggered, squelch is closed until a matching code is again received.

(2) Paging

Paging uses the DTMF signal to page or wait to be called by a specific station. Squelch is triggered when the 3-digit code output by the partner station matches that of your station. In contrast to code squelch, the partner station's code is displayed by the receiving station so that the operator can identify the caller.

This function can only be used in FM mode and when the optional CCL-267 tone unit is installed.

1) Programming codes

Before using paging, you must program a 3-digit code between 000 and 999 for your station into the transceiver. In addition, you must also program a 3-digit code between 000 and 999 for the partner station you expect to page. See 6.18, "User Definitions" for details of how to program the paging code and partner station code.

2) Operation

To use paging, select FM mode then press the **FBK/PAGE** key ⑫. The PAGE indicator lights on the LCD and paging mode is selected.

If your station now receives its paging code (which is the same as your station code), the transceiver beeps and the PAGE indicator on the LCD blinks. The code of the calling station is displayed on the LCD and squelch is triggered, allowing sounds from the partner station to be heard.

In this state, pressing the PTT or **XMIT** key transmits the code of the partner station that initiated the call and your station code, enabling the partner station to respond. This establishes communication.

To cancel receiving (or calling) and resume waiting for receiving (or calling), press the **CLR** key ②-5 on the key pad.

To page a specific station, you must first program the codes for the partner and your stations, then press the **FBK/PAGE** key ⑫ to turn on the PAGE indicator ⑮ on the LCD. Next, press the PTT switch on the microphone or the **XMIT** key ⑤ to transmit the partner and your station codes.

NOTE

1. Because the paging operation uses noise squelch, first adjust the SQ control ⑮ so that noise squelch is closed when there is no signal, then select paging mode.
2. The code is sent at the start of a transmission. However, note that the modulation signals from the MIC, etc., are muted while the code is sent.
3. When your station receives its paging code, the partner station's code is displayed on the frequency indicator on the LCD. Once transmission starts, the frequency is again displayed.

3) Automatic cancellation of paging

When you are called by paging, the transceiver sends the partner station code and communication is established. However, you can automatically cancel paging from the second transmission, making communication smoother.

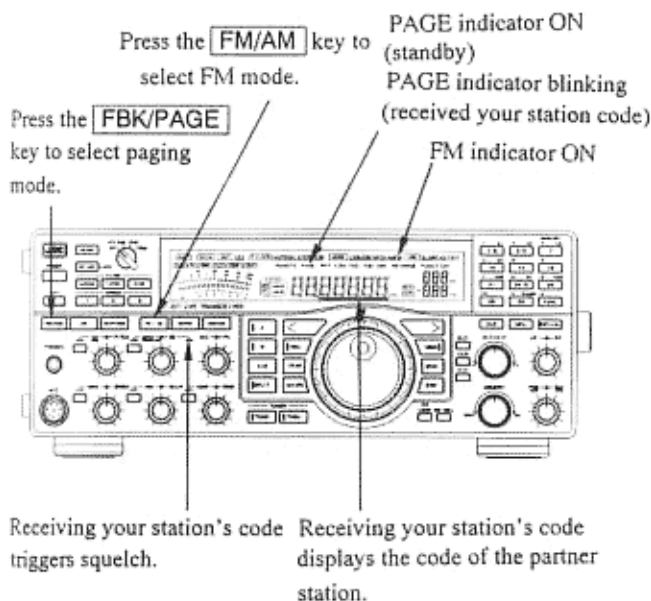

Figure 6.12 Switches and Indicators for Paging

6.16 Filter Combinations

The JST-145/245 uses 9.455MHz and 455kHz filters in cascade formation to enhance absolute attenuation and shaping factor.

Selecting the exact combination of filters is simplified by using the three FILTER keys ⑦. However, installation of

optional filters may prevent switching among the respective combinations.

The relationship between the FILTER keys ⑦ and the selected filters are shown in the following table.

Where multiple combinations are available, those nearer the top of the table take precedence.

	NARROW		INTER		WIDE	
	9.455MHz	455kHz	9.455MHz	455kHz	9.455MHz	455kHz
USB & LSB	*1.8kHz **2.7kHz *1.8kHz —	*1.8kHz *1.8kHz 2.7kHz —	**2.7kHz —	2.7kHz —	6kHz	2.7kHz
CW	*500Hz *1.8kHz **2.7kHz 6kHz —	*300Hz *300Hz *300Hz *300Hz —	*500Hz *1.8kHz **2.7kHz *500Hz *500Hz —	*500Hz *500Hz *500Hz *1.8kHz 2.7kHz —	*1.8kHz **2.7kHz *1.8kHz **2.7kHz 6kHz	*1.8kHz *1.8kHz 2.7kHz 2.7kHz 2.7kHz
AFSK	*500Hz *1.8kHz **2.7kHz *500Hz *500Hz —	*500Hz *500Hz *500Hz *1.8kHz 2.7kHz —	*1.8kHz **2.7kHz *1.8kHz —	*1.8kHz *1.8kHz 2.7kHz —	**2.7kHz 6kHz	2.7kHz 2.7kHz
AM	**2.7kHz 6kHz	2.7kHz 2.7kHz	6kHz	6kHz	LC	12kHz
FM	6kHz	6kHz	—	—	LC	12kHz

—: Filter switch not ON

*: Optional filter

** : Standard on JST-245. Optional on JST-145.

6.17 Connecting Peripheral Equipment

6.17.1 Electronic Keyer

Connect a manipulator using a commercially-available 6.0mm-diameter plug, as shown in Figure 6.13.

Then, turn on the ELECTRONIC KEYSER switch ⑥7.

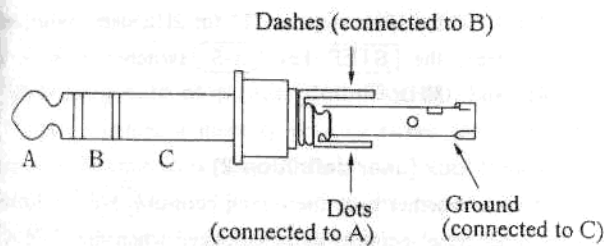

Figure 6.13 Connection of Electric Keyer

6.17.2 Linear Amp

Connect the optional CFQ-4794 control cable to the LINEAR AMP connector ⑦0 on the rear panel of the JST-145/245 to use JRC's JRL-2000 linear amp. See Figure 6.14 for how to connect a linear amp other than the JRL-2000F. Use a commercially-available 15-pin D-sub plug.

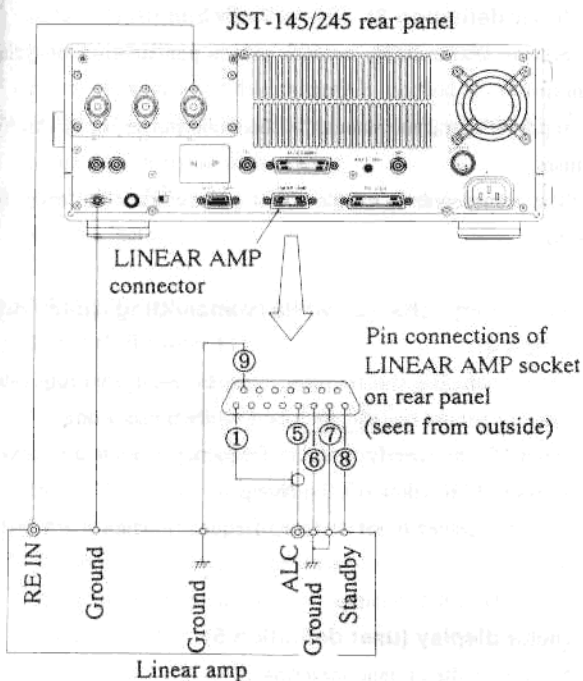

Figure 6.14 Connection of Linear Amp

6.17.3 Receiving Antenna and Separate Receiver

To receive using a special antenna other than those connected to the ANT connectors ④0, ④1, ④2 on the rear panel, connect the antenna to the RX ANT IN connector ④4 on the rear panel.

To receive using a separate receiver, connect the external receiver's antenna terminal to the RX ANT OUT connector ④5. This disconnects the internal receiver from the antenna circuit.

Figure 4.6 shows the internal connections of the RX ANT IN and RX ANT OUT connectors.

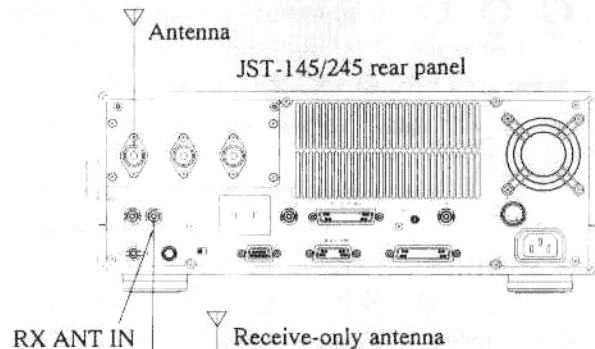

Figure 6.15 Connection of Receive-only Antenna

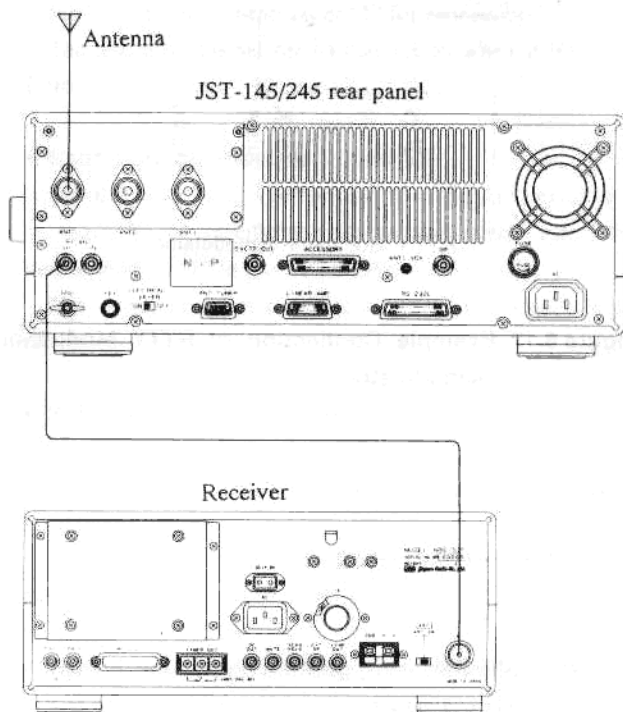

Figure 6.16 Connection of Separate Receiver

6.17.4 RTTY

To operate the JST-145/245 in RTTY (AFSK) mode requires a special modulator-demodulator. Figure 6.17 shows how to connect the modulator-demodulator, but see the instruction manual of the modulator-demodulator for details.

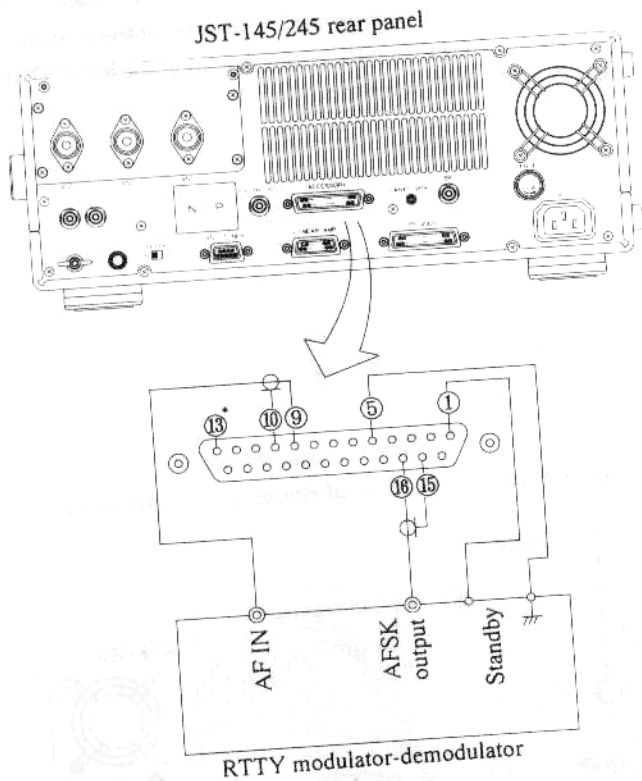

Figure 6.17 Example Connection of RTTY Modulator-Demodulator

6.18 User Definitions

The user definition procedure allows you to program some of the transceiver's functions to suit your own requirements.

6.18.1 Programmable Items

- **2Hz step (user definition 1)**

Selects the minimum step on the tuning control.

Input "0" for 10Hz steps or "1" for 2Hz steps. When set for 2Hz steps, the **STEP** key (1-5) switches between 2Hz, 10Hz, and 100Hz.

- **Panel lock (user definition 2)**

Selects whether only the tuning control (1-6) is locked or the other panel controls are also locked when the **LOCK** key is used

Input "0" to lock only the tuning control or "1" to lock the tuning control and other panel controls.

The following keys remain operative when "1" is specified:

POWER key, ATT control, **XMIT** key, AF control, and RF control

and KF control

- **Number of pulses per rotation of tuning control (user definition 3)**

Selects 2000, 1000, or 500 pulses per rotation of tuning control.

Input "0" for 2000 pulses, "1" for 1000 pulses, or "2" for 500 pulses.

The transceiver is set to 2000 pulses when it leaves the factory.

- **Frequency change while transmitting (user definition 4)**

Selects whether the frequency can be changed using either the tuning control or **◀▶** keys while transmitting

Input "0" to specify that the frequency cannot be changed (fixed) or "1" to allow it to be changed.

The transceiver is set to fixed frequency when it leaves the factory.

- **Meter display (user definition 5)**

Selects needle or band metering

Input "0" for needle metering or "1" for band metering.

The transceiver is set to band metering when it leaves the factory.

- **Electric keyer weighting (user definition 6)**

Sets the ratio between dots and dashes of the electronic keyer in 0.1 steps between 1:2.5 and 1:4.5.

The dot:dash ratio is set to 1:3 when the transceiver leaves the factory.

• **Beep (user definition 7)**

Selects whether a beep is output when keys are operated.

Input "1" to output a beep or "0" to turn off the beep.

The transceiver is set to beep when keys are operated when it leaves the factory.

• **Scanning auto stop (user definition 8)**

Selects whether a memory scan or sweep (program scan) pauses when squelch is triggered.

Input "1" to pause or "0" to continue the scan or sweep.

The transceiver is set to pause when it leaves the factory.

• **Skip empty channels when scanning (user definition 9)**

Sets the transceiver to skip empty channels (channels with no data written to them) when making a memory scan.

The transceiver is set to skip empty channels when it leaves the factory.

• **Antenna selection when recalling a memory channel (user definition 10)**

Selects whether to use antenna selection data stored in a memory channel when that channel is recalled.

Input "0" to allow manual antenna selection or "1" to use antenna data stored in memory.

The transceiver is set to use data stored in memory when it leaves the factory.

• **NFG-230 connecting antenna connector (user definition 11)**

To control an antenna tuner, the CPU must check the NFG-230 connection. When the specified antenna connector is selected, the CPU outputs data for the NFG-230.

Input "0" if not using the NFG-230, "1" to connect to antenna connector 1, "2" to connect to antenna connector 2, and "3" to connect to antenna connector 3.

The transceiver is set for not connecting the NFG-230 when it leaves the factory.

• **JRL-2000F connecting antenna connector (user definition 12)**

To control an antenna coupler, the CPU must check the JRL-2000F connection. When the specified antenna connector is selected, the CPU outputs data for the JRL-2000F.

Input "0" if not using the JRL-2000F, "1" to connect to antenna connector 1, "2" to connect to antenna connector 2, and

"3" to connect to antenna connector 3.

The transceiver is set for not connecting the JRL-2000F when it leaves the factory.

• **Connection to antenna connector 2 (user definition 13)**

Determines whether an antenna is connected to antenna connector 2.

When set to "no antenna connected", the transceiver ignores antenna switch ⑨ even when it is pressed.

Input "0" for no connection or "1" for connection.

The transceiver is set for no connection when it leaves the factory.

• **Connection to antenna connector 3 (user definition 14)**

Determines whether an antenna is connected to antenna connector 3.

When set to "no antenna connected", the transceiver ignores antenna switch ⑨ even when it is pressed.

Input "0" for no connection or "1" for connection.

The transceiver is set for no connection when it leaves the factory.

• **Shift direction (user definition 15)**

Sets the shift direction (offset) in FM mode shift operation.

Input "0" to specify a shift to the minus side when transmitting, or "1" to specify a shift to the plus side.

The transceiver is set to shift to the minus side when it leaves the factory.

• **Shift width (user definition 16)**

Sets the shift width FM shift operation.

You can set any frequency between 0 and 500kHz using the main tuning control.

The transceiver is set to a 100kHz shift when it leaves the factory.

• **Tone output when shifting (user definition 17)**

Sets whether a transmit tone is output in FM mode.

Input "1" to output a tone or "0" if not required.

The transceiver is set to output no tone when it leaves the factory.

• **Tone method when shifting (user definition 18)**

Selects the tone method used when adding a transmit tone in FM mode.

Input "0" to use the CTCSS method or "1" to use the burst method.

The transceiver is set to the CTCSS method when it leaves the factory.

- **Tone frequency when shifting (user definition 19)**
Sets the tone frequency to be used when adding a transmit tone (CTCSS) in FM mode
Set one of 38 tones between 67.0 and 250.3Hz.
The transceiver is set to 88.5Hz when it leaves the factory.

- **Register your station and partner station codes for using DTMF (user definition 20)**

For using DTMF, you can program one your station and 9 partner station codes. For paging, you can program one code for the partner station.

Figure 6.18 shows the LCD display when entering user definition 20. The display shows the station, P0 being the your station code and P1 to P9 being partner station code. PC is the partner station for paging. The RIT/XIT control (40) switches through P0 to P9, then PC. The mark to the top right of P1 to P9 shows the partner station specified in user definition 21.

The last three digits are the code. Use the numeric key pads to change the code within the range 000 to 999.

All codes are preset to "000" when the transceiver leaves the factory.

Select using RIT/XIT control (40)

P0: your station

P1 to P9: partner stations

PC: partner station for paging function

The code between P1 and P9 that blinks is the code specified in user definition 21.

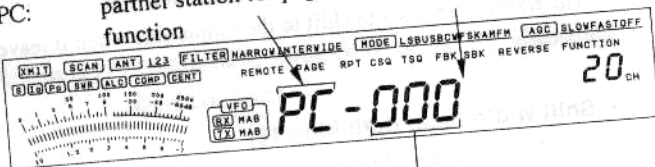

Selected in the range 000 to 999 using MEMORY control (40)

Figure 6.18 Code Registration

- **Specify partner station code for DTMF (user definition 21)**

When using DTMF, you can specify using the RIT/XIT control (40) one of the partner station codes registered in user definition 20 as the current code.

P1 is specified when the transceiver leaves the factory.

- **FSK shift (user definition 22)**

Selects the shift (frequency) to use in FSK mode
You can select a shift of 170, 425, or 850Hz.

The transceiver is set to 170Hz when it leaves the factory.

- **FSK mark frequency (user definition 23)**

Selects an FSK mark frequency of 2125Hz or 1275Hz

The transceiver is set to 2125Hz when it leaves the factory.

- **Tone frequency for tone squelch (user definition 24)**

Sets the tone frequency for use when receiving using tone squelch

Set one of 38 tones between 67.0 and 250.3Hz.

The transceiver is set to 88.5Hz when it leaves the factory.

- **RIT/XIT frequency display (user definition 25)**

Selects whether or not to add the RIT or XIT frequency, when used, to the frequency displayed on the main display

The transceiver is set not to add the RIT/XIT frequency when it leaves the factory.

- **1kHz steps in FM mode (user definition 26)**

You can set the maximum step on the tuning control in FM mode to 1kHz.

When set for 1kHz steps, the [STEP] key (1-5) switches between 10Hz, 100Hz, and 1kHz.

The transceiver is set to 10Hz, 100Hz step when it leaves the factory.

Table 6.3 Table of User Definitions

User Definition No.	Item	Content (parameter)	Factory Default
1	2Hz steps	10Hz: 0 2Hz: 1	10Hz
2	Panel lock	Tuning control only: 0 Tuning control and other panel controls: 1	Tuning control only
3	Tuning control pulses	2000 pulses: 0 1000 pulses: 1 500 pulses: 2	2000 pulses
4	Change frequency while transmitting	Fixed: 0 Variable: 1	Fixed
5	Meter display	Needle: 0 Band: 1	Band
6	Electric keyer weighting	1:2.5 to 1:4.5	1:3
7	Beep tone	OFF: 0 ON: 1	ON
8	Scanning auto stop	OFF: 0 ON: 1	ON
9	Skip empty channels when scanning	OFF: 0 ON: 1	ON
10	Antenna selection on recalling a memory channel	Manual selection: 0 Automatic selection: 1	Automatic selection
11	NFG-230 antenna connector selection	Not connect: 0 Antenna connector 1: 1 Antenna connector 2: 2 Antenna connector 3: 3	Not connected
12	JRL-2000F antenna connector selection	Not connect: 0 Antenna connector 1: 1 Antenna connector 2: 2 Antenna connector 3: 3	Not connected
13	Antenna 2 connector	Not connected: 0 Connected: 1	Not connected
14	Antenna 3 connector	Not connected: 0 Connected: 1	Not connected
15	Shift direction in FM shift operation	Direction of shift in relation to receiving frequency when transmitting: Minus: 0 Plus: 1	Minus
16	Shift frequency	0 to 500kHz	100kHz
17	Tone output	No tone: 0 Tone: 1	No tone
18	Tone method	CTCSS: 0 Burst: 1	CTCSS

1. 基准频率微调。在RX状态下按 F/W/C, 按 USB/LSB 与现109, 可以±200Hz调整
2. 电源电路选择, 在RX状态下按 F/W/C, 按 RFAMP 与现110 '0' 表示 "1" 使用内置

User Definition No.	Item	Content (parameter)	Factory Default
19	Tone frequency	One of 38 tones between 67 and 250.3Hz	88.5Hz
20	Register your and partner station codes for DTMF operation	3-digit number	000
21	Specify partner station code for DTMF operation Shift		P1
22	Shift for FSK mode	170Hz 425Hz 850Hz	170Hz
23	Mark frequency for FSK mode	2125Hz 1275Hz	2125Hz
24	Tone frequency for tone squelch in FM mode	One of 38 tones between 67 and 250.3Hz	88.5Hz
25	RIT/XIT frequency display	Do not add to main frequency display: 0 Add to main frequency display: 1	No
26	1kHz step in FM mode	No: 0 Yes: 1	No

6.18.3 Setting User Definitions

1) Select user definition mode

Press the **[FUNC]** key (2-1). The FUNCTION indicator (2) lights on the LCD. Press the **[ENT/kHz]** key (2-3). This displays the user definition number "1" in the channel indicator (8) on the LCD. The current setting is displayed in the frequency display (15).

2) Select a user definition number

Rotate the MEMORY control (3) to select a user definition number, as displayed in the channel indicator on the LCD.

3) Change the setting in the selected user definition

Rotate the RIT/XIT control (4) to select the desired setting for the displayed user definition.

4) Finish of user definition

To finish of user definition, press the **[CLR]** key (2-5), or turn off the power supply, or wait for at least 10 seconds without touching any controls.

6.19 PC Control of the Transceiver

The JST-145/245 can be externally controlled by devices such as PCs via the RS-232C interface.

- Baud rate: 4800 bps
- Format: 1 start bit, 8 data bits, no parity bit, 1 stop bit (10 bits/character)
- Items under PC control: Frequency, mode, bandwidth, AGC, PBS, BWC, tuner control, transmit or receive, channel settings, memory channel recall/storing, break-in method, antenna selection, squelch status, noise blanker, transceiver status requests, meter select, user definitions
- Output items: Frequency, mode, bandwidth, AGC, recalled contents of memory channel, metering, squelch status, and tuning status

6.19.1 Connection via RS-232C

Connect the RS-232C connector of the JST-145/245 to that of a PC using an RS-232C cable (commercially available crossed cable with 25-pin DSUB male connectors at either end). You can also use JRC's optional 6ZCJD00350 RS-232C cable. Table 6.3 shows the cable connections.

Table 6.3 RS-232C Connector Signals and Connections

Signal	Pin		Pin	Signal
JST-145/245			Computer	
(FG)	1	—————	1	(FG)
(SD)	2	—————	2	(SD)
(RD)	3	—————	3	(RD)
(RS)	4	—————	4	(RS)
-	-	—————	5	(CS)
-	-	—————	6	(DR)
(SG)	7	—————	7	(SG)
-	-	—————	8	(CD)
(ER)	20	—————	20	(ER)

6.19.2 Description of Control Commands

This section describes the format of the commands used to control the JST-145/245.

[Control ID], [Control details], [CR]

The control ID is a single uppercase letter.

The length of the control details depend on the control ID, but they consist of numerals 0 to 9.

The CR (carriage return) is a delimiter.

The following details each of the items that can be controlled.

• "H" External control ON/OFF

Command	Content	Response
"H" CR	Control status request	"Hn" CR n: 0, 1
"H0" CR	Control OFF	
"H1" CR	Control ON	

When using a PC to control the JST-145/245, first turn the control ON.

When external control is turned ON, the REMOTE segment of the LCD and the LED on the LOCK switch  light. Except for the power switch, ATT switch, AF and RF nob on the front panel, all controls and keys are electrically locked.

When external control is turned OFF, the REMOTE segment of the LCD and the LED on the LOCK switch  turn OFF. You can then again use the controls on the panel. Note that external control is turned off if the power switch is turned off.

• "A" Select antenna

Command	Content
"A1" CR	ANT1
"A2" CR	ANT2
"A3" CR	ANT3

• "B" Select bandwidth

Command	Content
"B0" CR	WIDE
"B1" CR	INTER
"B2" CR	NARR

• "C" Select channel

Command	Content	Response
"C" CR	Memory mode	"Cccc" CR: active "CcccV" CR
"Cccc" CR	ccc channel selection	ccc: 001 to 200

• "D" Select mode

Command	Content
"D0" CR	RTTY
"D1" CR	CW
"D2" CR	USB
"D3" CR	LSB
"D4" CR	AM
"D5" CR	FM

• "E" Store data in memory channel

Command	Content
"E1" CR	Store data in memory channel

This command stores the frequency, mode, bandwidth, AGC, antenna in use, RF AMP ON/OFF, SPLIT information, and in FM mode, shift and tone squelch statuses to the channel displayed on the channel indicator.

- "F" Set transmit and receive frequencies

Command	Content
"FA"CR	A-VFO
"FB" CR	B-VFO
"F00100000A" CR	Set 100kHz in A-VFO
"F29999998A" CR	Set 29.999998MHz in A-VFO
"F00100000B" CR	Set 100kHz in B-VFO
"F29999998B" CR	Set 29.999998MHz in B-VFO

- "G" Select AGC

Command	Content
"G0" CR	SLOW
"G1" CR	FAST
"G2" CR	OFF

- "I" Output transceiver settings ON/OFF

Command	Content
"I" CR	Output current status
"I0" CR	Output OFF
"I1" CR	Output ON

When set to output settings, the REMOTE segment on the LCD lights and the current settings are output to the PC in the following format:

Output	Content
"Iabdfg" CR	Output of current settings

- I: Header code
- a: A digit (between 1 and 3) showing antenna in use
- b: A digit (between 0 and 2) showing the bandwidth
- d: A digit (between 0 and 5) showing the mode
- f: Eight digits (between 00100000 and 53999998) showing transmit and receive frequency (between 00100000 and 29999998 on the JST-145)
- g: A digit (between 0 and 2) showing the AGC

If you change the settings using the front panel controls when output is ON, the changes are sent in the above format to the PC. The REMOTE segment on the LCD turns off when output is off. Output automatically turns off when the power switch is turned off.

- "J" Write to memory channel

Command	Content
"J1ccc" CR	Write to memory channel

(where ccc is the channel number between 001 and 200)

The frequency, mode, bandwidth, AGC, antenna used, RF AMP ON/OFF, SPLIT data, and in FM mode shift and tone squelch statuses, displayed on the LCD are written to channel ccc. The channel number in the display does not change when data is written to a memory channel.

- "K" Set channel data

Command	Content
"Kcccabdfg" CR	Set channel data

K: Header code

ccc: Channel number (between 001 and 200)

a: A digit (between 1 and 3) showing antenna to be used

b: A digit (between 0 and 2) showing the bandwidth

d: A digit (between 0 and 5) showing the mode

f: Eight digits (between 00100000 and 53999998) showing transmit and receive frequency (00100000 and 29999998 on the JST-145)

g: A digit (between 0 and 2) showing the AGC

Setting channel data does not change the LCD display.

- "L" Recall channel data

Command	Content
"L" CR	Read current data
"Lssssee" CR	Read channel data

(where sss is the number of the first channel and eee is the number of the last channel)

Data is output from the transceiver in the following format:

- 1) When no channel is specified:

Output	Content
"LAabdfg" CR	A-VFO operating data
"LBabdfg" CR	B-VFO operating data
"LMabdfg" CR	Memory mode operating data

2) When a channel is specified:

Output	Content
"Lsssabdfg" CR	Data for first channel
"Lnnnabdfg" CR	Data for intermediate channels
"Leeeabdfg" CR	Data for last channel

L: Header code

sss: Number of first channel to read (example: 001)

nnn: Number of intermediate channel to read (example: 100)

eee: Number of last channel to read (example: 200)

a: A digit (between 1 and 3) showing antenna in use

b: A digit (between 0 and 2) showing the bandwidth

d: A digit (between 0 and 5) showing the mode

f: Eight digits (between 00100000 and 53999998) showing transmit and receive frequency (00100000 and 29999998 on the JST-145)

g: A digit (between 0 and 2) showing the AGC

The data for each channel occupies 17 characters. Therefore, to output all channels requires $17 \times 200 = 3400$ characters. It takes $3400 \times 10/4800 =$ about 7 seconds to output data for all channels.

If you read a channel that contains no data, "V" is output in the antenna position (example: "L199V" CR).

• "M" Switch meter display

Command	Content	Response
"M" CR	Output meter information	"Mmnn" CR (where m is the type of metering and nn is a value between 00 and 40)

The data from the transceiver's meter display is converted from analog to digital format. The value is always between 00 and 40 and is always highlighted.

Command	Content
"M0" CR	Receiving: S meter
"M1" CR	Receiving: FM center meter
"M2" CR	Transmitting: Power meter
"M3" CR	Transmitting: SWR meter
"M4" CR	Transmitting: ALC meter
"M5" CR	Transmitting: COMP meter
"M6" CR	Transmitting: ID meter

The meter display can only be switched when transmitting. When receiving, only the S meter is displayed. However, in FM mode, you can switch between S meter and FM center meter.

• "N" Select noise blanker

Command	Content	Response
"N" CR	Current NB status	"Nn" CR n: 0, 1, 2
"N0" CR	NB OFF	
"N1" CR	NB 1	
"N2" CR	NB 2	

• "O" Break-in method in CW mode

Command	Content	Response
"O" CR	Current CW status	"On" CR n: 0, 1, 2
"O0" CR	Side tone monitor	
"O1" CR	Semi break-in	
"O2" CR	Full break-in	

• "P" Set PBS frequency

Command	Content	Response
"P" CR	Current PBS status	"Psnnnn" CR
"P-2000" CR	Set PBS to -2kHz	s: +, -
		nnnn: 0 to 2000
"P+2000" CR	Set PBS to +2kHz	

• "Q" Squelch setting

Command	Content
"Q" CR	Current squelch status
"Q0" CR	Tone squelch and code squelch OFF
"Q1" CR	Tone squelch ON
"Q2" CR	Code squelch ON
"Q3" CR	Paging ON

Data is output in the following format:

Output	Content
"Q0" CR	Squelch open
"Q1" CR	Squelch closed

• "R" VOX setting

Command	Content	Response
"R" CR	Current VOX status	"Rn" CR n: 0, 1
"R0" CR	VOX OFF	
"R1" CR	VOX ON	

• "S" Set channel data

Command	Content
"Scccabdfg" CR	Set channel data

S: Header code

ccc: Channel number between 001 and 200

a: A digit (between 1 and 3) showing antenna in use

b: A digit (between 0 and 2) showing the bandwidth

d: A digit (between 0 and 5) showing the mode

f: Eight digits (between 00100000 and 53999998) showing transmit and receive frequency (00100000 and 29999998 on the JST-145)

g: A digit (between 0 and 2) showing the AGC

Setting the channel data changes the displayed data.

• "T" Tuner control

The transceiver outputs a response when a tuner is specified.

Command	Content
"T0" CR	Stop all tuning
"T1" CR	Operate internal tuner
"T2" CR	Operate optional NFG-230 tuner
"T3" CR	Operate JRL-2000F linear amp

Output	Content
"T0" CR	Tuning complete
"T1" CR	Internal tuner tuning complete
"T2" CR	NFG-230 tuning complete
"T3" CR	JRL-2000F tuning complete

• "U" Change user definitions

This command allows you to change the user definitions made according to 6.18. "User Definitions."

The 2-digit number following "U" is the user definition number and is followed by the new setting for that user definition.

(1) Main tuning control steps

Command	Content	Response
"U01" CR	Request dialing step status	"U01n" CR n: 0, 1
"U010" CR	10Hz step	
"U011" CR	2Hz step	

(2) Panel lock

Command	Content	Response
"U02" CR	Panel lock status	"U02n" CR n: 0, 1
"U020" CR	Only tuning control locked	
"U021" CR	All panel controls locked	

(3) Tuning control pulses

Command	Content	Response
"U03" CR	Pulse status	"U03n" CR n: 0-2
"U030" CR	2000 pulses	
"U031" CR	1000 pulses	
"U032" CR	500 pulses	

(4) Changing frequency during transmission

Command	Content	Response
"U04" CR	Request status of frequency change during transmitting	"U04n" CR n: 0, 1
"U040" CR	Frequency fixed during transmitting	
"U041" CR	Frequency variable during transmitting	

(5) Meter display

Command	Content	Response
"U05" CR	Meter display status	"U05n" CR n: 0, 1
"U050" CR	Meter display: needle	
"U051" CR	Meter display: band	

(6) Set electric keyer weighting

Command	Content	Response
"U06" CR	Weighting status	"U06ww" CR ww: 25-45
"U06ww" CR	Set weighting ww	

(7) Beep tone

Command	Content	Response
"U07" CR	Beep tone status	"U07n" CR n: 0, 1
"U070" CR	OFF	
"U071" CR	ON	

(8) Auto-stop in scanning

Command	Content	Response
"U08" CR	Auto stop status	"U08n" CR n: 0, 1
"U080" CR	Auto stop: OFF	
"U081" CR	Auto stop: ON	

(9) Skip empty channels

Command	Content	Response
"U09" CR	Skip empty channel status	"U09n" CR n: 0, 1
"U090" CR	Do not skip	
"U091" CR	Skip	

(10) Antenna selection on recall memory

Command	Content	Response
"U10" CR	Request antenna switching status	"U10n" CR n: 0, 1
"U100" CR	Not interlinked	
"U101" CR	Interlinked	

(11) Connection for NFG-230

Command	Content	Response
"U11" CR	Status of connection for NFG-230	"U11n" CR n: 0~3
"U110" CR	Do not connect NFG-230	
"U111" CR	ANT1	
"U112" CR	ANT2	
"U113" CR	ANT3	

(12) Connection for JRL-2000F

Command	Content	Response
"U12" CR	Status of connection for JRL-2000F	"U12n" CR n: 0~3
"U120" CR	Do not connect JRL-2000F	
"U121" CR	ANT1	
"U122" CR	ANT2	
"U123" CR	ANT3	

(13) Use of antenna connector 2 (ANT2)

Command	Content	Response
"U13" CR	Connection status	"U13n" CR n: 0, 1
"U130" CR	Not connected	
"U131" CR	Connected	

(14) Use of antenna connector 3 (ANT3)

Command	Content	Response
"U14" CR	Connection status	"U14n" CR n: 0, 1
"U140" CR	Not connected	
"U141" CR	Connected	

(15) Shift direction in FM mode

Command	Content	Response
"U15" CR	Shift status	"U15n" CR n: 0, 1
"U150" CR	Shift to minus side	
"U151" CR	Shift to plus side	

(16) Shift frequency in FM shift operation

Command	Content	Response
"U16" CR	Shift frequency status	"U16kkkh" CR where kkk: kHz digits (000 to 499) h: 100Hz digits (0 to 9)
"U16kkkh" CR	Sets shift frequency	

(17) Tone output in FM shift operation

Command	Content	Response
"U17" CR	Tone status	"U17n" CR n: 0, 1
"U170" CR	No tone	
"U171" CR	Tone	

(18) Tone system when shifting in FM mode

Command	Content	Response
"U18" CR	Tone system status	"U18n" CR n: 0, 1
"U180" CR	CTCSS	
"U181" CR	BURST	

(19) Tone frequency when shifting in FM mode

Command	Content	Response
"U19" CR	Tone frequency status	"U19nn" CR nn: 01 to 38
"U19nn" CR	nn: Frequency when adding transmit tone (see Table 6.2)	

(20) Set codes for DTMF

Command	Content	Response
"U20" CR	Code status	"U20nccc" CR
"U200ccc" CR	Set your station code	n: 0 to 9, C
"U20nccc" CR	Set partner station code	ccc: 000 to 999

The response consists of the code for the your station, partner station (1-9) and the paged station (C).

(21) Specify partner station code

Command	Content	Response
"U21" CR	Status of code specification	"U21n" CR n: 1 to 9
"U21nccc" CR	Specify Pn	ccc: 000-999

(22) Shift width in FSK mode

Command	Content	Response
"U22" CR	Status of shift width	"U22n" CR n: 0 to 2
"U220" CR	170Hz	
"U221" CR	425Hz	
"U222" CR	850Hz	

(23) FSK mark frequency

Command	Content	Response
"U23" CR	Mark frequency status	"U23n" CR n: 0, 1
"U230" CR	Mark frequency: 2125Hz	
"U231" CR	Mark frequency: 1275Hz	

(24) Tone frequency for tone squelch

Command	Content	Response
"U24" CR	Tone frequency status	"U24nn" CR
"U24nn" CR	Set tone frequency to nn	nn: 01 to 38

(25) Method of displaying RIT/XIT frequency

Command	Content	Response
"U25" CR	Status of adding frequency display	"U25n" CR n: 0, 1
"U250" CR	Do not add to frequency display	
"U251" CR	Add to frequency display	

(26) 1kHz step in FM mode

Command	Content	Response
"U26" CR	1kHz step status	"U26n" CR n: 0, 1
"U260" CR	No 1kHz step	
"U261" CR	1kHz step	

• "V" Tuning rate

Command	Content	Response
"V" CR	Request tuning rate report	"Vn" CR n: 0,1,2,3
"V0" CR	2Hz	
"V1" CR	10Hz	
"V2" CR	100Hz	
"V3" CR	1kHz	

Note that 2Hz step is available except for FM mode.

1kHz step is available only in FM mode.

• "W" Set BWC

Command	Content	Response
"W" CR	Request BWC band status	"Wnnnn" CR
"W+" CR	BWC band: max	
"W-" CR	BWC band: min	
"Wnnnn" CR	Specify BWC band	

where nnnn is a 4-digit number in Hz.

• "X" Select either transmit or receive

Command	Content	Response
"X" CR	Request status	"Xn" CR n: 0, 1
"X0" CR	Receive	
"X1" CR	Transmit	

• "Y" Automatic frequency increase/decrease

Command	Content	Response
"Y" CR	Request status report	"Yn" CR n: 0,+,-
"Y0" CR	Stop increase/decrease	
"Y+" CR	Increase	
"Y-" CR	Decrease	

• "Z" Initial settings

Command	Content
"Z1" CR	Clear memory channels 1 to 200
"Z2" CR	Initialize user definitions
"Z3" CR	Initialize internal tuner
"Z4" CR	Clear RAM

6.19.3 Sample Program

The following sample program is written in BASIC for the NEC PC-9800 Series of PCs. If using other PCs, be sure to set the baud rate, etc., of the RS-232C port.

```

10 OPEN "COM: N81NN" AS #1      Open RS-232C port
20 ,
30 PRINT #1, "H1"              Set remote control ON
40 PRINT #1, "F07050000A"      Set frequency to
                                7.05MHz in A-VFO
50 PRINT #1, "A1"              Select ANT1
60 PRINT #1, "D3"              Select LSB mode
70 PRINT #1, "G0"              Set AGC SLOW
80 PRINT #1, "H0"              Set remote control
                                OFF
90 ,
100 CLOSE                       Close RS-232C port
110 END

```

Section 7. Adjustments and Maintenance

Your JST-145/245 has been completely adjusted and has passed through strict quality control at the factory. There is therefore no need to readjust before use.

Fine adjustments other than those described in this section require well-trained engineers and sophisticated measuring instruments. If readjustment is required, please consult the sales office where you bought the transceiver, or JRC.

7.1 Removing the Cover

CAUTION

Turn OFF the POWER switch ⑥ and disconnect the power cable BEFORE removing the covers.

Remove the JST-145/245 covers as shown in Figure 7.1. Also remove the carrying handle.

The PA unit is installed on the top chassis. When removing the top chassis, for example to install a filter on the TX/RX unit, refer to Figure 7.2.

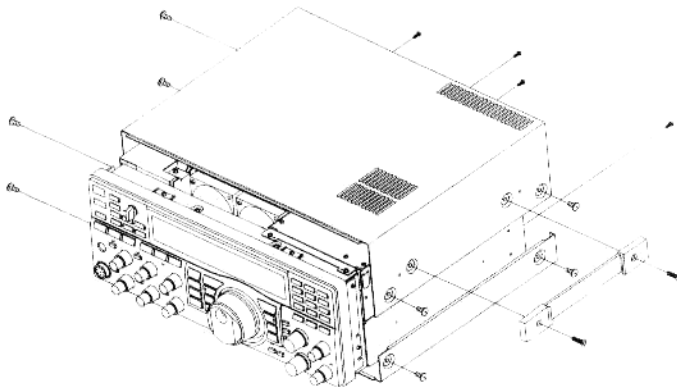

Figure 7.1 Removing the Covers

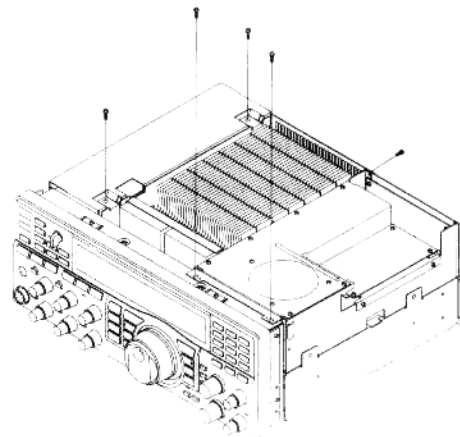

Figure 7.2 Removing the Top Chassis

7.2 Making Adjustments

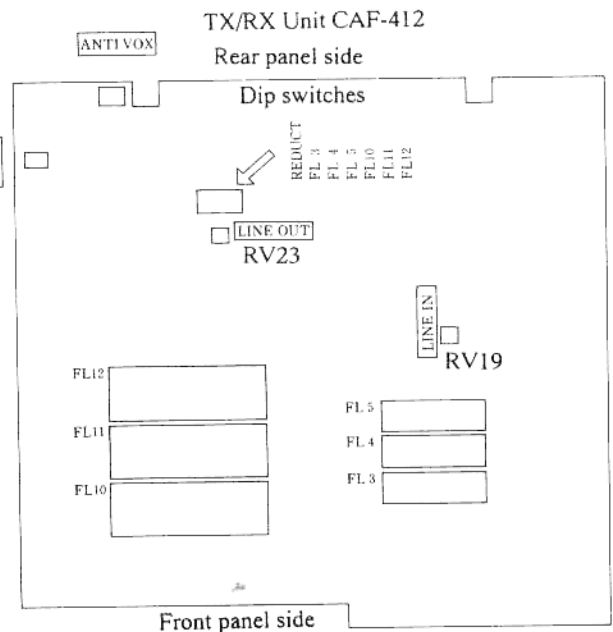

Figure 7.3 Positions of Adjusters and Switches

(1) ANTI VOX adjuster

The ANTI VOX adjuster is on the CAF-412 TX/RX unit, and can be adjusted from the rear panel (Volume ⑰) on the

rear panel).

Adjust to prevent VOX operation being triggered by sounds from the speaker when using VOX.

(2) LINE IN adjuster

The LINE IN adjuster adjusts the level of external input from an RTTY, etc., via the LINE IN accessory connector on the rear panel.

Remove the covers as shown in Figure 7.1, then remove the power amplifier and tuner (chassis) to expose the TX/RX unit.

The **LINE IN** adjuster is to right center of the TX/RX unit (Figure 7.3).

Adjust the line in level according to the operation manual of device being connected. Note that some device have built-in level adjusters.

The line in level is adjusted -33dBm when it leaves the factory.

(3) LINE OUT adjuster

The LINE OUT adjuster adjusts the level of signals output by the transceiver via the LINE OUT accessory connector on the rear panel.

The **LINE OUT** adjuster is also on the TX/RX unit in front of the dip switches (Figure 7.3). Adjust the line out level according to the operation manual of device being connected.

The line out level is adjusted -2dBm when it leaves the factory.

(4) BEEP adjuster

The BEEP adjuster adjusts the volume of the beep output from the speaker when a key pad key is pressed or an error occurs.

The **BEEP** adjuster is on the left side of the TX/RX unit. Adjust the beep to the desired volume.

This adjuster has no effect when the beep has been turned off using user definition 7.

7.3 Maintenance

7.3. Components

ICs, transistors, FET and diodes can be destroyed even by momentary shorts. Care must therefore be exercised in carrying out any adjustments, etc.

7.3.2 Fuses

If a fuse blows, thoroughly investigate the cause before replacing it with one of the same capacity. The JST-145DX/

245DX uses 10A fuses. Always use a fuse of the correct capacity, and never use fuse of different capacities.

CAUTION

Turn OFF the POWER switch ⑥ and disconnect the power cable BEFORE replacing a fuse.

7.3.3 Adjusting the Standard Oscillator

- (1) Remove the covers as described in 7.1
- (2) Turn ON the POWER switch ⑥ and receive a standard frequency station (JJY, WWV, etc.) in CW mode. Make sure all digits including the 10Hz digit is tuned to the frequency.
- (3) Press and hold the METER switch ③, then adjust the trimmer capacitor on the front of the CGH-192 synthesizer unit (Figure 7.4) to achieve a zero beat. Normally, adjust CV10. If using a high stability crystal, set switch SJ1 to high-stability crystal and adjust CV11.
- (4) This completes adjustment of the standard oscillator. Turn the POWER switch ⑥ OFF and replace the lower covers.

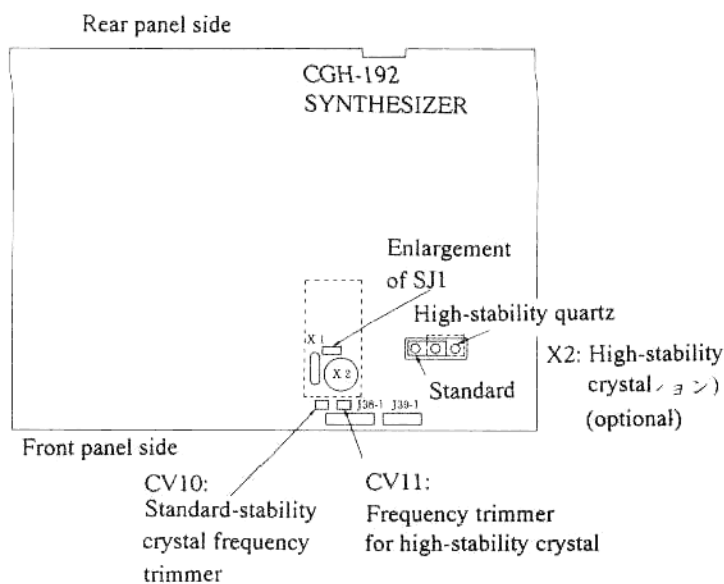

Figure 7.4 Frequency Adjustment

7.3.4 Replacing Memory Backup Battery

A lithium battery is used to backup the memory. Battery life is about five years.

If data recalled from memory is corrupted or you cannot store new data, replace the lithium battery. The battery type is CR-2032 (3V) manufactured by SANYO, or equivalent. If you have difficulty in locating a replacement battery, please consult the sales office from which you bought the transceiver, or JRC.

The replacement procedure is as follows:

- (1) Turn OFF the POWER switch ⑥ and disconnect the power cable.
- (2) Remove the front cover.
- (3) The lithium battery is located in a holder on the left of the CPU unit toward the main unit. Pull the lever and lift the battery to remove it.
- (4) Insert a new lithium battery into the holder.
- (5) Replace the cover, then reset the CPU.

See 7.4.5 for how to reset the CPU.

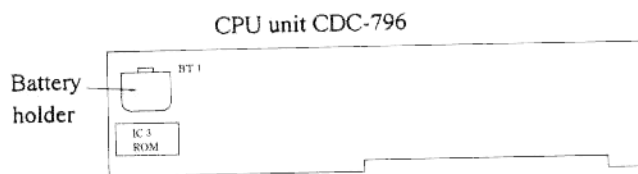

Figure 7.5 Replacement of Lithium Battery

NOTE

Settings such as frequency and user definitions are lost and will need reprogramming when the lithium battery is replaced.

7.4.5 Resetting the CPU

Reset the CPU as follows if the CPU is not functioning normally, such as when the display is disrupted or operation is abnormal as a result of an external factor, or when the battery is replaced.

- (1) Turn OFF the POWER switch ⑥.
- (2) Press and hold the CLR switch (2-5) while turning ON the POWER switch ⑥.
- (3) Turn OFF the POWER switch ⑥.
- (4) Turn ON the POWER switch ⑥. This completes resetting of the CPU.

NOTE

Memory channel data, user definitions, antenna tuner constants, etc., are cleared to the factory defaults when the CPU has been reset and must be reprogrammed as required.

Section 8. Notes on Operation

Mobile Operation

Many amateur radio frequency bands are close to the bands used for commercial purposes. If an amateur radio station is operated in close proximity to the sites of commercial stations, unforeseen interference may occur, even though the amateur station is operating correctly. Take care, therefore, when operating mobile or portable amateur stations under these conditions.

Amateur radio transmitters may, under certain circumstances, cause interference to domestic radios, stereos, HiFi systems, etc. This may occur because of poor design of the domestic equipment, and the radio amateur may not be at fault. Such cases of interference should be reported to the appropriate regulatory body in the country concerned.

The flow chart below should be followed so as to check whether the interference is being caused by a fault in the transmitter or domestic equipment, and suggests ways of minimizing any problems.

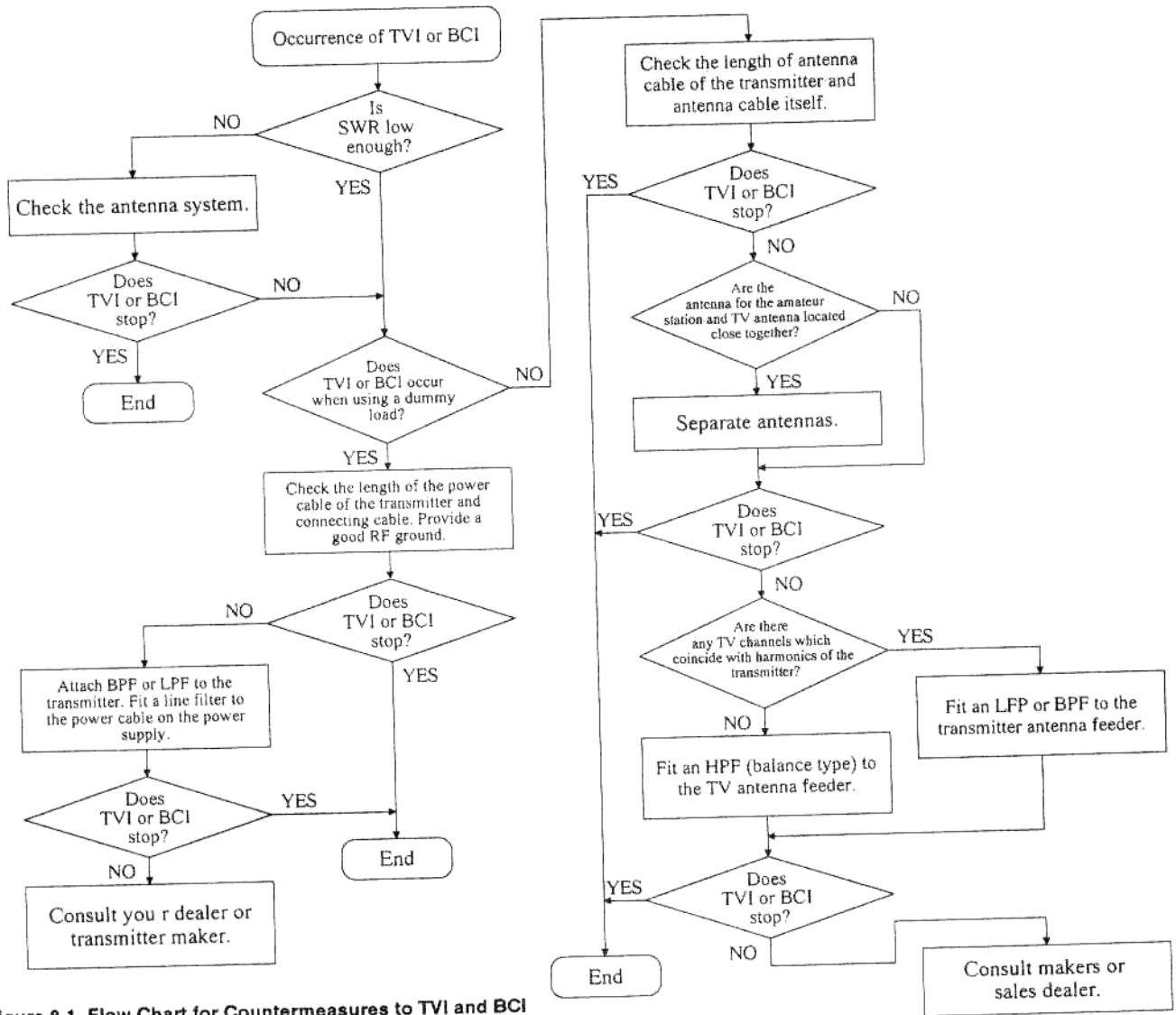

Figure 8.1 Flow Chart for Countermeasures to TVI and BCI

Section 9. Troubleshooting

The JST-145/245 has many advanced features and it is possible that the transceiver may not operate quite as you expect, particularly if you have not familiarized yourself with the operating procedures. If you experience difficulty, please read the operation manual again before assuming that the transceiver is faulty.

This section describes various symptoms caused by misoperation and mistakes in installation, handling and operating. These symptoms do not mean that the transceiver has failed, and you should thoroughly investigate before asking for the transceiver to be repaired. If the transceiver will still not operate normally even after careful checking, you should refer the problem to the dealer from whom you purchased the equipment.

9.1 Troubleshooting in Reception

No.	Symptom	Cause	Countermeasures
1	No display with POWER switch on	① Poor connection at power plug. ② Fuse blown	① Check the connection at the plug. ② Investigate the cause and replace with new fuse of the same capacity.
2	With POWER switch on, the frequency display works but there is no sound.	① Headphones are plugged in. ② Squelch is closed. ③ The XMIT indicator is on and the transceiver is in the transmitting condition. ④ The AF GAIN control is set to fully counterclockwise position.	① Disconnect the headphones. ② Set squelch to open. ③ Set standby switch or PTT to OFF. ④ Adjust it to the desired position.
3	Dim display	The dimmer control is set to the minimum position.	Set the control for the desired illumination
4	The S-meter deflects with no signal.	Set RF GAIN control is not turned fully clockwise.	Turn the RF GAIN control fully clockwise.
5	The received sound is distorted.	① AGC is set to OFF. ② The receiving frequency is incorrect. ③ Faulty setting of mode switch. ④ The notch filter is ON. ⑤ The PBS control is not set at the center. ⑥ The BWC control is not set fully counterclockwise. ⑦ NB is operating. ⑧ NOTCH is operating.	① Set the AGC to FAST or SLOW. ② Retune. ③ Set the mode switch to receive signals. ④ Set the notch filter OFF. ⑤ Set the PBS control to the center. ⑥ Rotate the BWC control fully counterclockwise. ⑦ Set NB to OFF. ⑧ Set NOTCH to OFF.
6	No frequency change by rotating the TUNING control. Switch operations are impossible.	The LOCK switch is set to ON.	Set the LOCK switch to OFF.
7	Faulty sensitivity	ATT is set to ON.	Set ATT to OFF.
8	BANDWIDTH cannot be changed in SSB, CW, or AFSK modes.	The optional filter is not installed.	Install the optional filter.

9.2 Troubleshooting on Transmission

No.	Symptom	Cause	Countermeasures
1	No output with XMIT switch ON.	<ul style="list-style-type: none"> ① Po control is turned fully counterclockwise ② The transmitting frequency is out of an amateur radio band. ③ "0" is displayed. 	<ul style="list-style-type: none"> ① Turn the Po control fully clockwise. ② Return transmit frequency to an amateur radio band. ③ Transmission is impossible when frequency is not stored in memory.
2	No output in the SSB mode.	<ul style="list-style-type: none"> ① MIC control is turned fully counterclockwise. ② Faulty microphone. 	<ul style="list-style-type: none"> ① Turn the MIC control clockwise to the appropriate level. ② Check the microphone.
3	No output by keying down in the CW mode	<ul style="list-style-type: none"> ① VOX is set to OFF in the semi-break-in operation. ② Full-break-in operation is not selected. ③ Faulty key. 	<ul style="list-style-type: none"> ① Set VOX to ON. ② Set the FBK switch to ON. ③ Check the key.
4	Low ID reading and high SWR reading on meters during transmission.	<ul style="list-style-type: none"> ① The antenna is not connected. ② The VSWR of the antenna is high. 	<ul style="list-style-type: none"> ① Check the antenna. ② Check the antenna.
5	Poor SSB, AM, and FM sound in transmission	<ul style="list-style-type: none"> ① The distortion is caused by a too high microphone input level. ② The COMP control is set too high. 	<ul style="list-style-type: none"> ① Adjust the MIC control. ② Adjust the COMP control.

Section 10. Peripheral Equipment and Options

10.1 Peripheral Equipment and Options

The following options are available to enhance the operation of the JST-145/245.

Name	Model	Note
Linear amp	JRL-2000F	
Antenna tuner	NFG-230 NFG-183 NFG-97	Automatic type, water resistant type. Internal installation type (standard on JST-245). Manual type
Speakers	NVA-319 NVA-88	With internal AF filter
Microphone	NVT-56 NVT-58 NVT-57	Stand microphone Handheld microphone with up/down switch Handheld microphone
Monitor unit	CMF-144	For monitoring signals transmitted by you.
Tone unit	CCL-267	For tone squelch and code squelch.
High stable crystal kit	CGD-135	
9.455MHz filter	CFL-316 CFL-317 CFL-318	500Hz 1.8kHz 2.7kHz
455kHz filter	CFL-231 CFL-232 CFL-218A	300Hz 500Hz 1.8kHz
Headphones	ST-3	
Control cable	CFQ-4794	For JRL-2000F control.

10.2 Installing Optional Equipment

Be sure to turn the POWER switch **Ⓜ** OFF and disconnect the power cable before starting work. Do not remove any units which are not concerned with the mounting of options.

10.2.1 Installing Units

See the instruction manuals of the respective optional units that are internally installed. These include the CMF-144 monitor unit and CCL-267 tone unit. Also see the instruction manual for the NFG-183 antenna tuner unit.

10.2.2 IF Filter

There are three types of 9.455MHz optional IF filters (the 2.7kHz filter is already installed in the JST-245) and three types of 455kHz filter.

Method:

- 1) Remove the upper covers.
- 2) Remove the PA unit chassis. Take care not to damage the cables.
- 3) Screw down the filter in the specified location on the CAF-412 TX/RX unit, then solder the terminals.
- 4) Turn ON the filter switch.
- 5) Replace PA unit chassis and covers.

Table 10.1 Positions of Filter

Position	Filter	Center Frequency	Band Width
FL12	CFL-231	455kHz	0.3kHz
FL11	CFL-232	455kHz	0.5kHz
FL10	CFL-218A	455kHz	1.8kHz
FL5	CFL-316	9.455MHz	0.5kHz
FL4	CFL-317	9.455MHz	1.8kHz
FL3	CFL-318	9.455MHz	2.7kHz

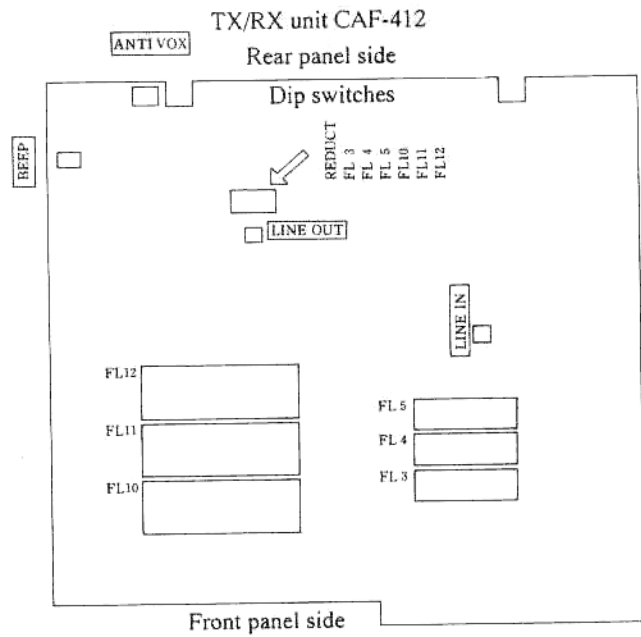
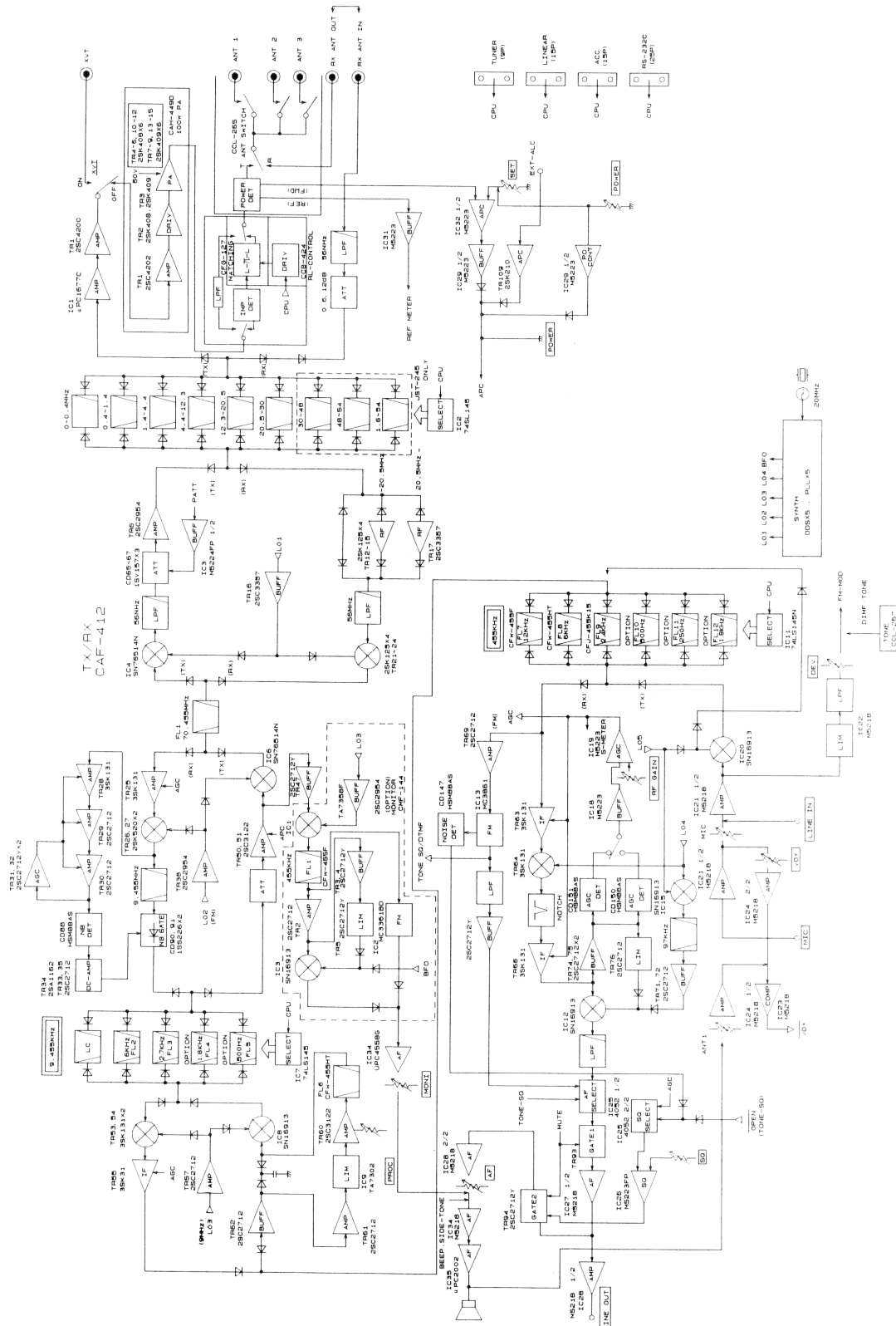

Figure 10.1 Positions of Filter and Filter Switch

Section 11. Block Diagram

11.1 Signal System



Section 12. Circuit Diagram

- 12.1 CDE-783 Panel
- 12.2 CAF-412 TX/RX Unit
- 12.3 CGH-192 Synthesizer Unit
- 12.4 CAH-449-D PA Unit
- 12.5 CFJ-157 LPF Unit
- 12.6 CFG-127 Matching Unit (JST-245, standard; JST-145, optional)
CCB-424 RL-Control Unit (JST-245, standard; JST-145, optional)
- 12.7 CCC-284 Sensor Unit (JST-245, standard; JST-145, optional)
- 12.8 CCL-265 ANT Switch Unit
- 12.9 CDC-796 CPU Unit
- 12.10 CCL-227 Tone Unit (Optional)
- 12.11 CMF-144 Monitor Unit (Optional)
- 12.12 JST-145 Overall Connection Diagram
JST-245 Overall Connection Diagram

12.2 CAF-412 TX/RX Unit (1/4)

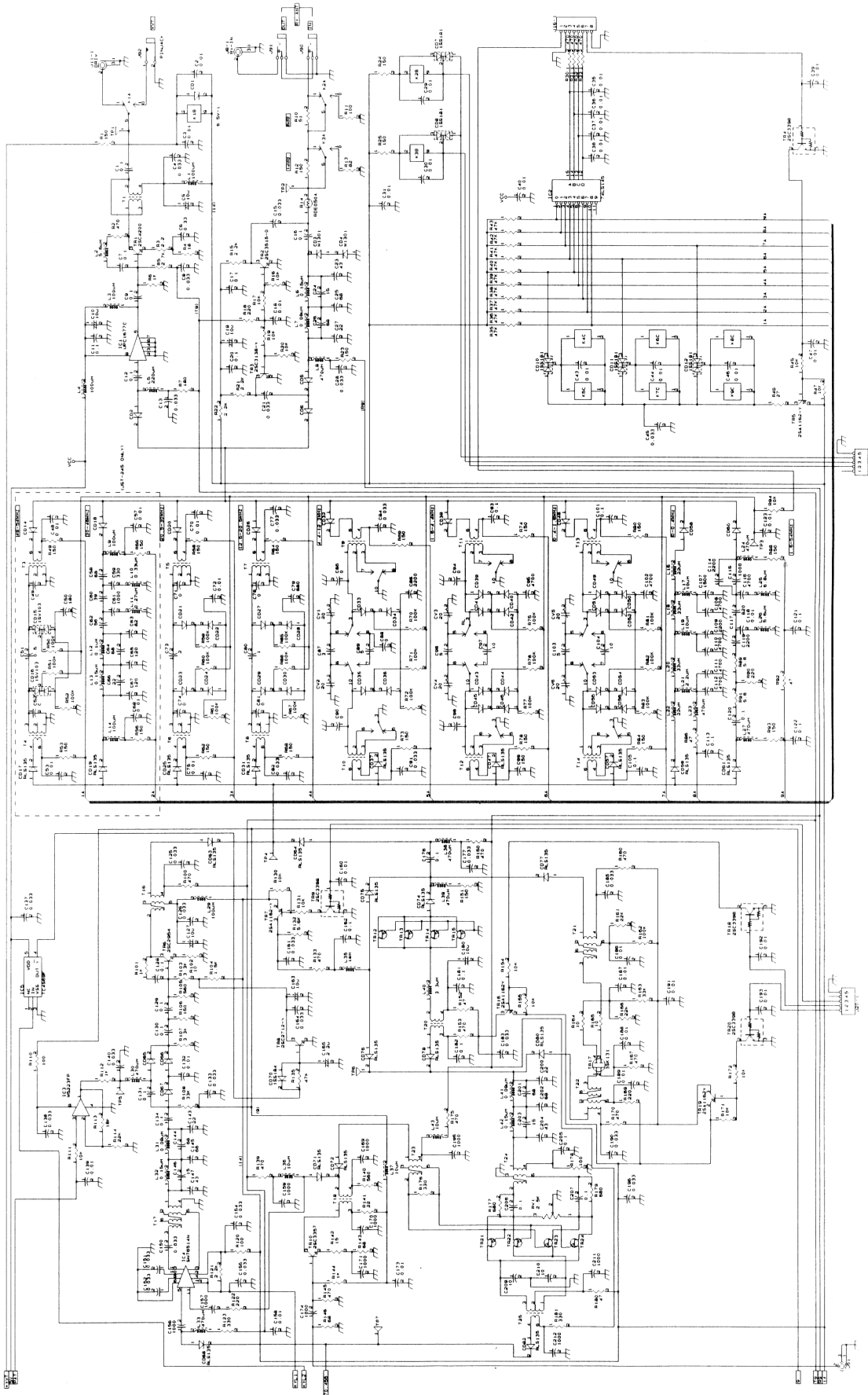

12.3 CGH-192 Synthesizer Unit (1/3)

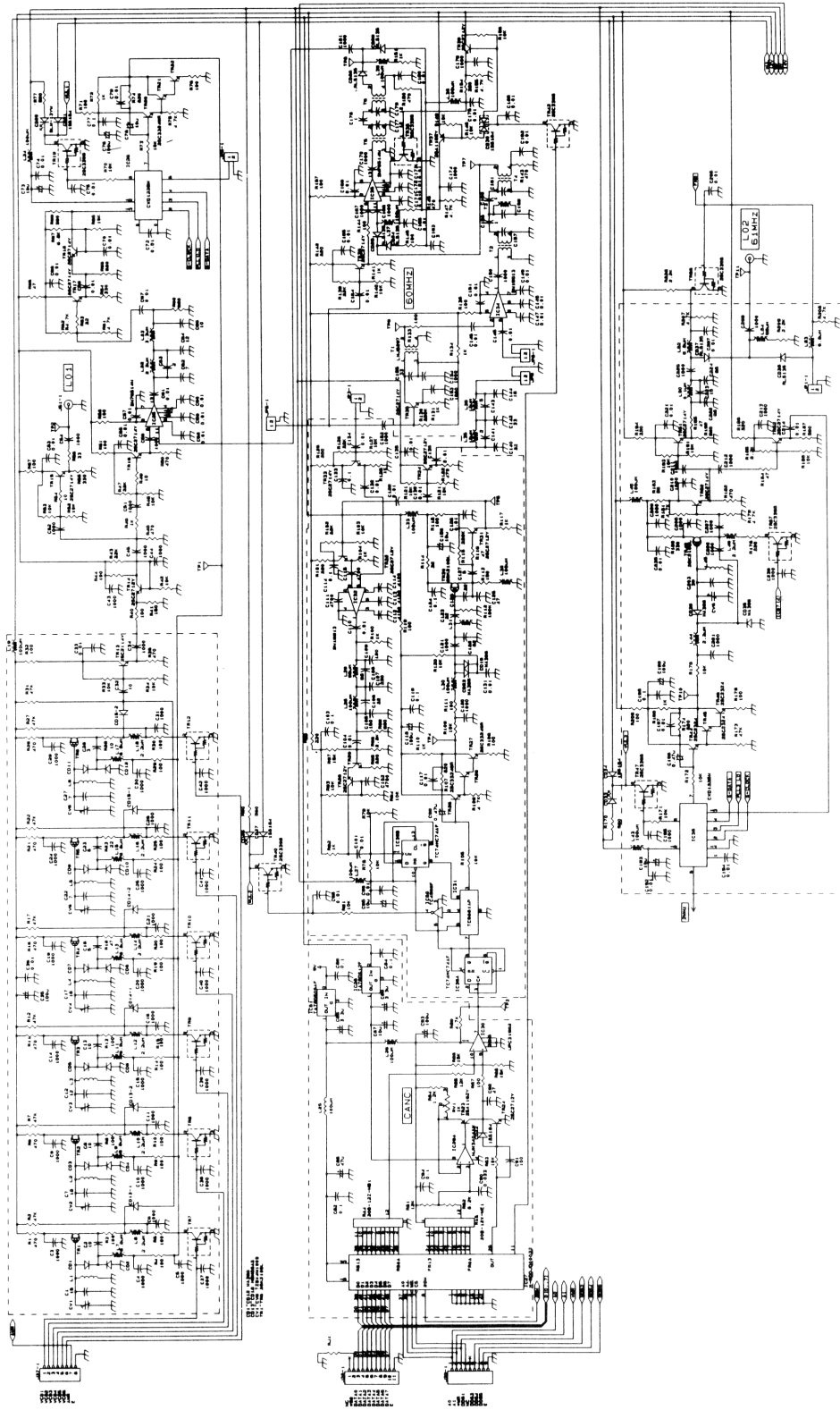

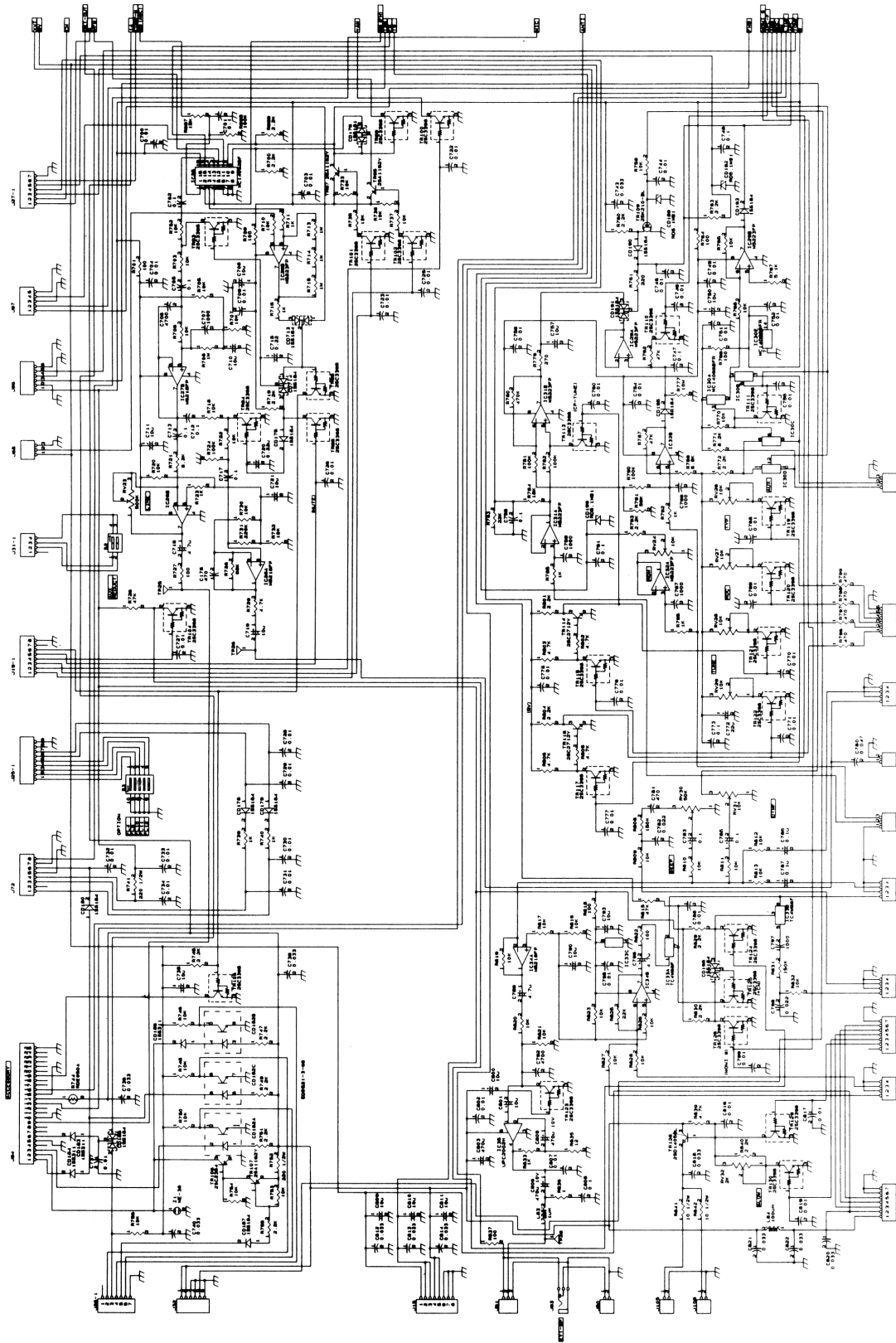

12.3 CGH-192 Synthesizer Unit (2/3)

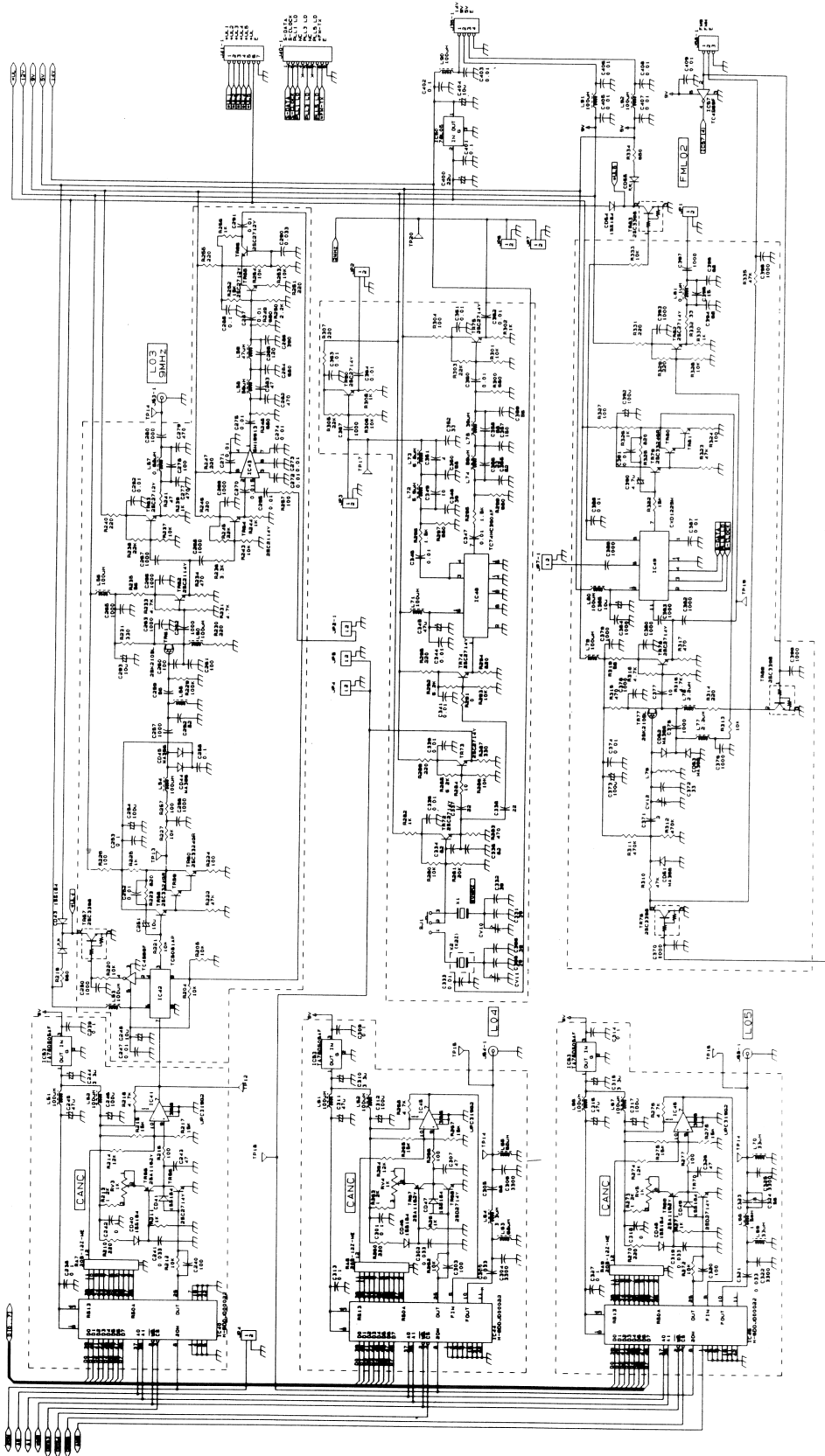

12.3 CGH-192 Synthesizer Unit (3/3)

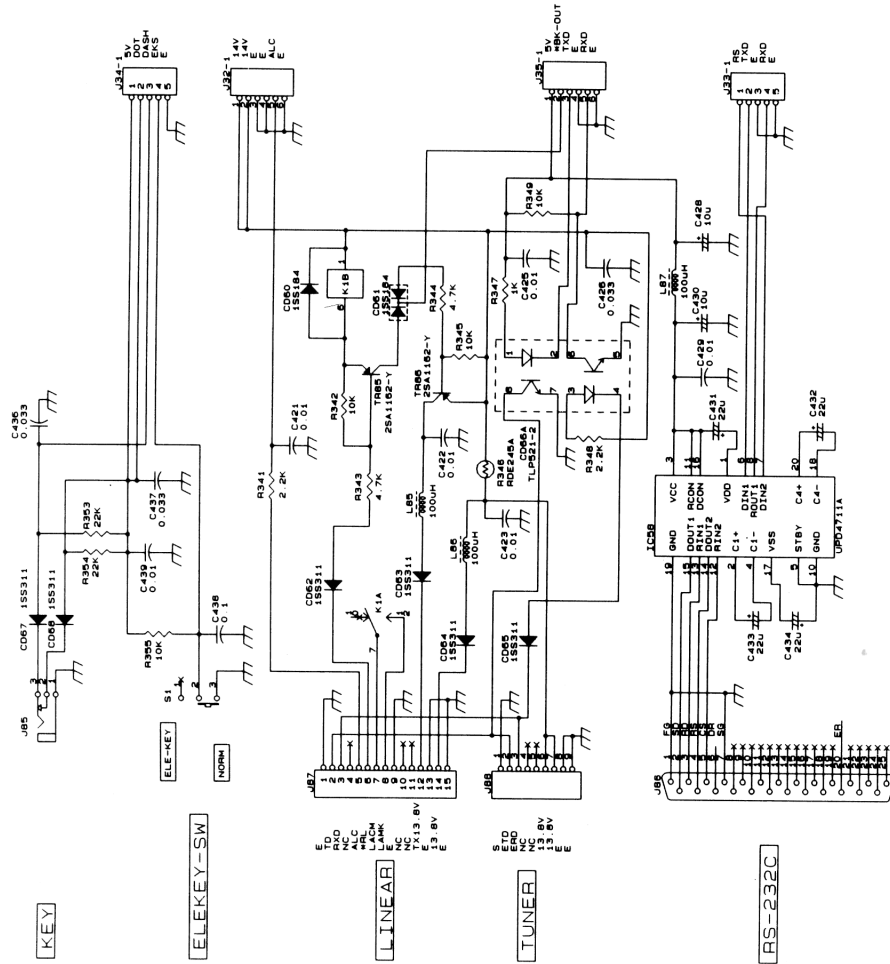

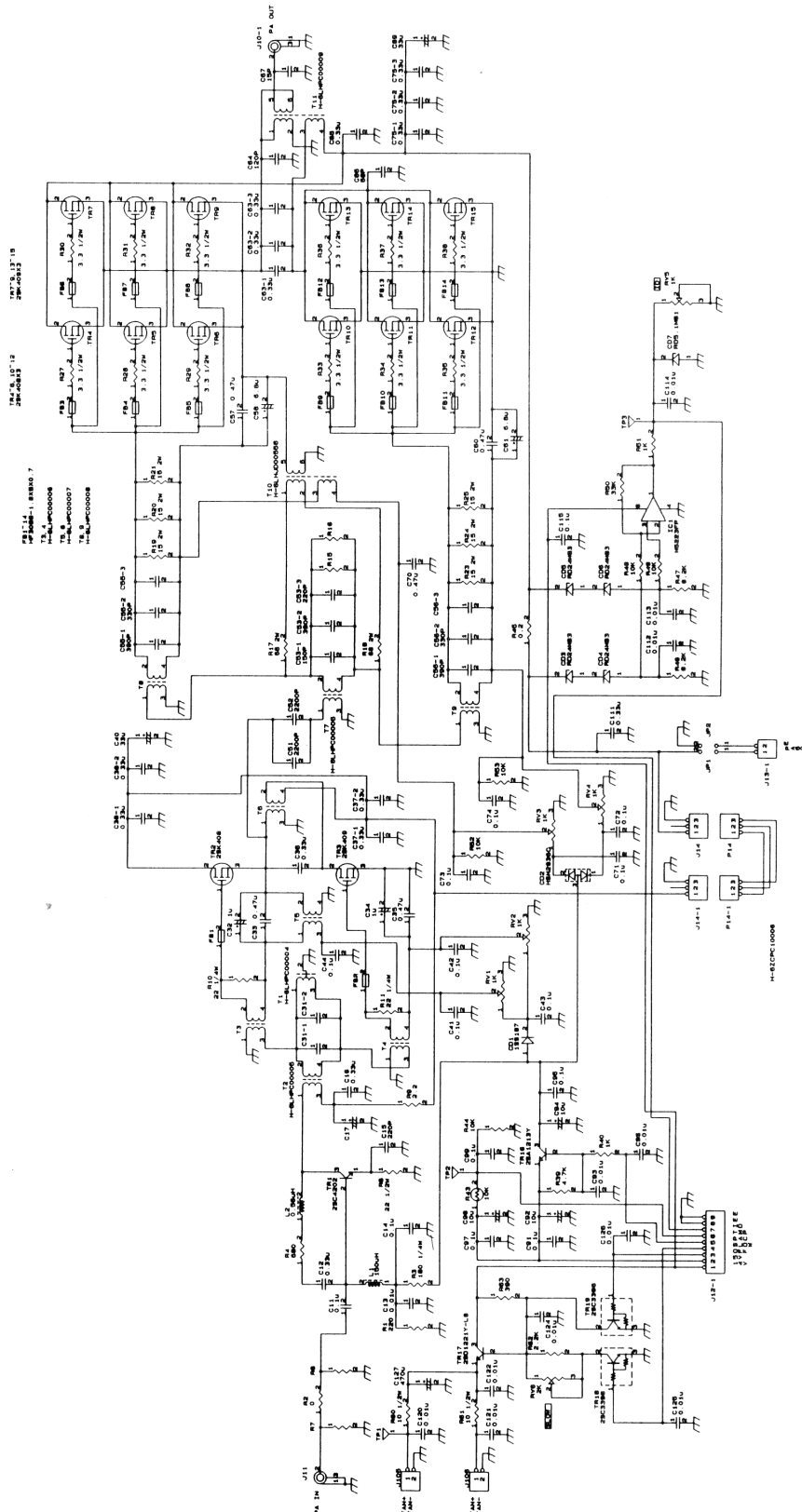

12.5 CFJ-157 LPF Unit

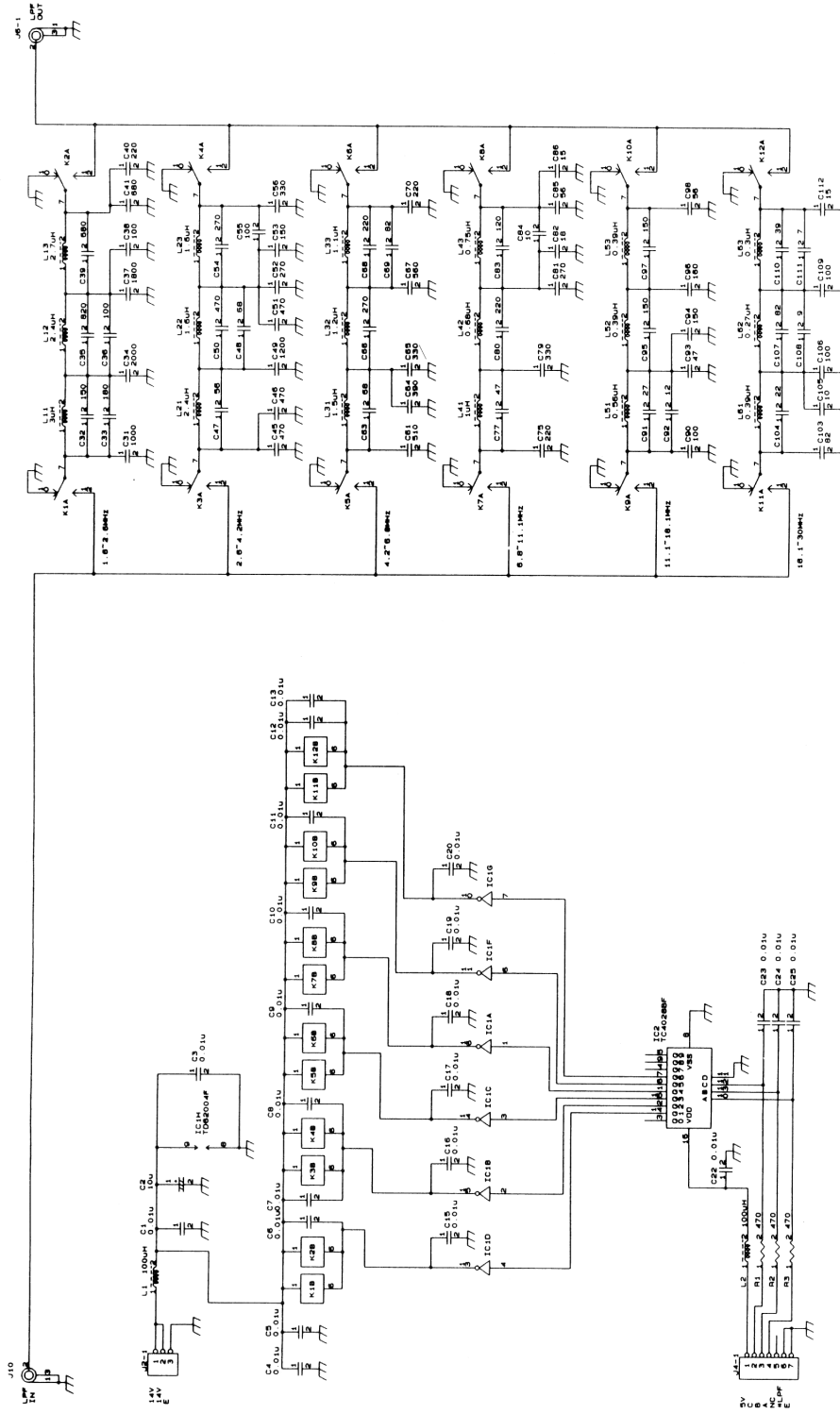

***9PC-000894
 ***9PD-000057

12.6 CFG-127 Matching Unit (JST-245, standard; JST-145, optional)
 CCB-424 RL-Control Unit (JST-245, standard; JST-145, optional)

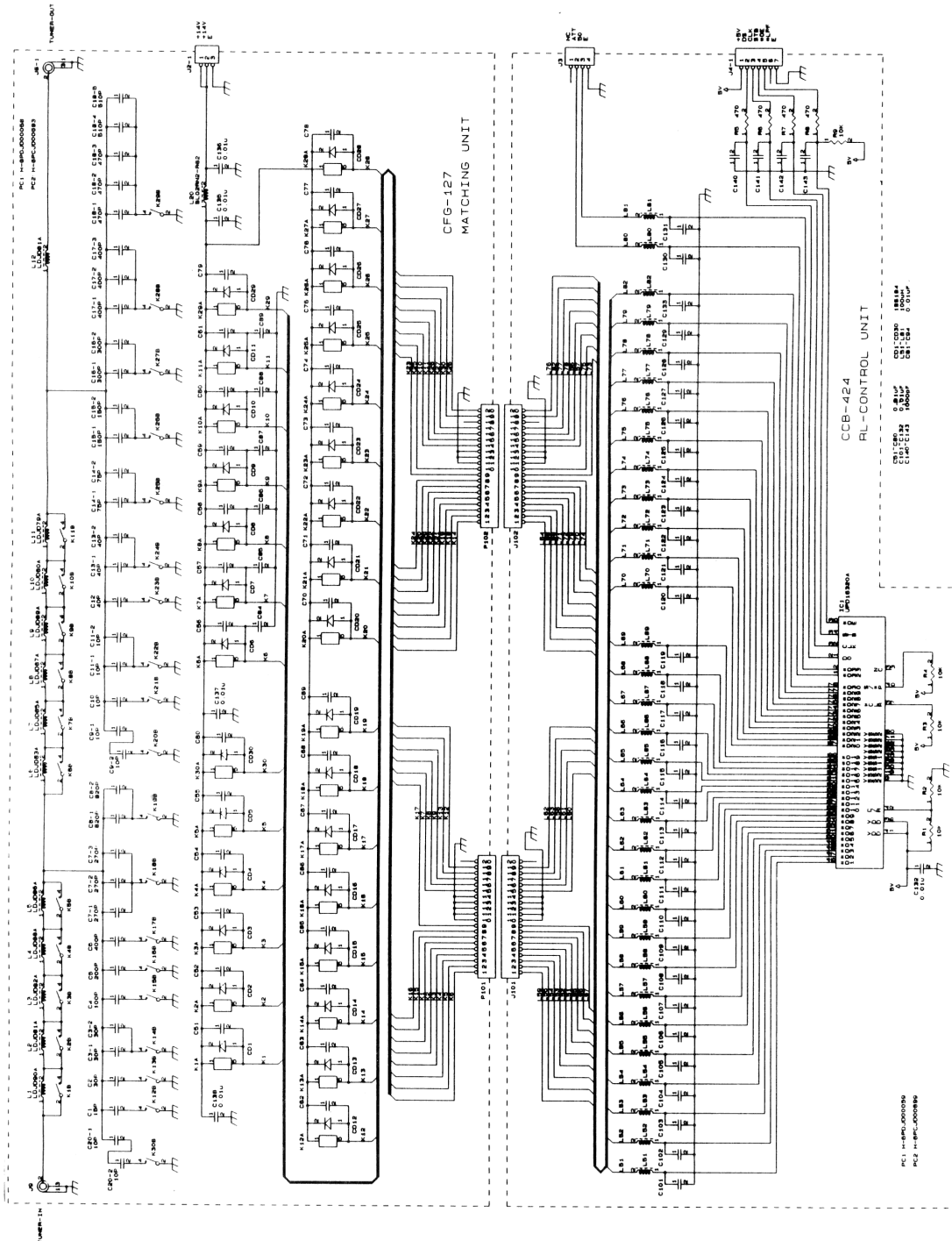

12.9 CDC-796 CPU Unit

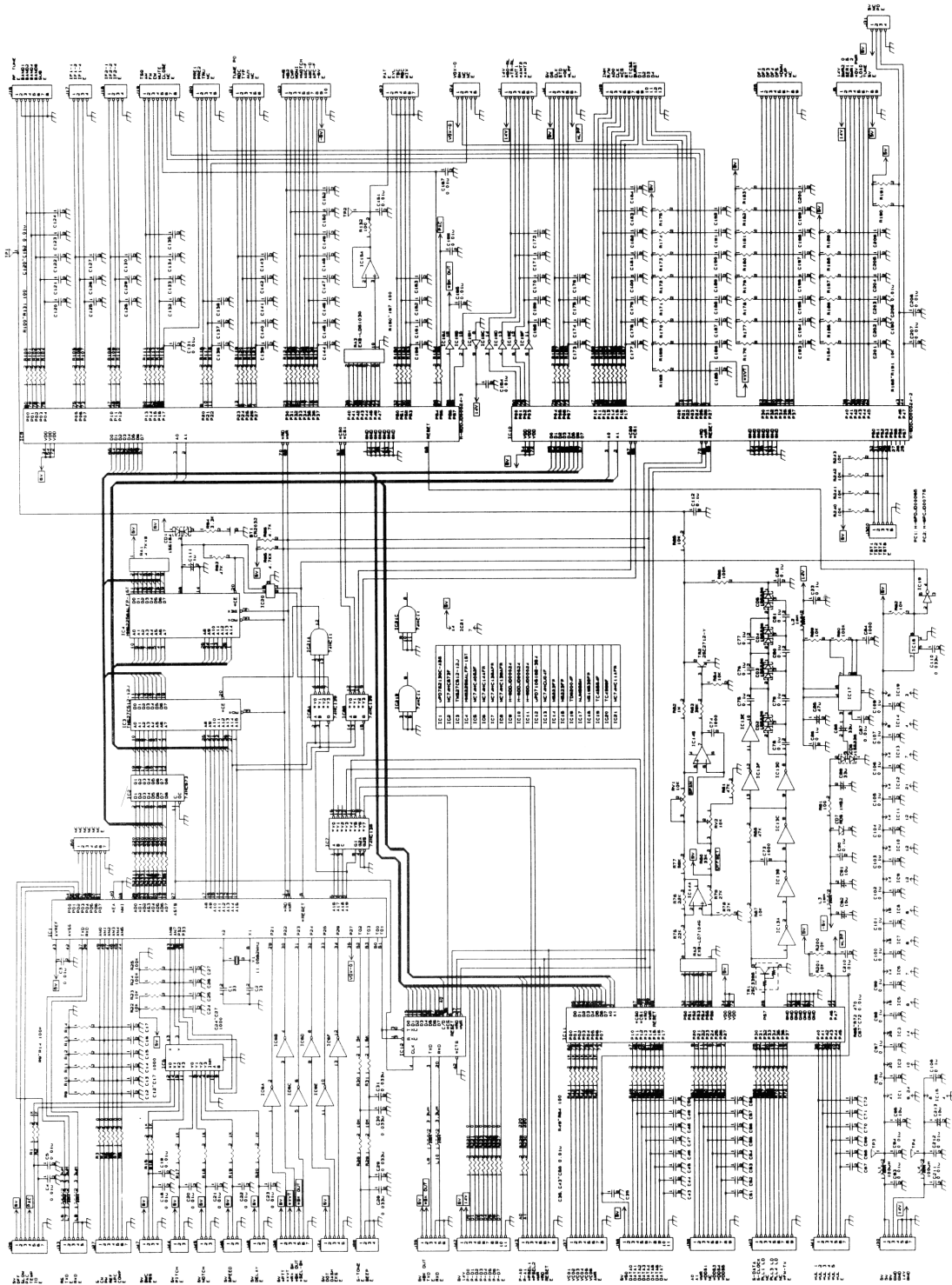

12.10 CCL-227 Tone Unit (Optional)

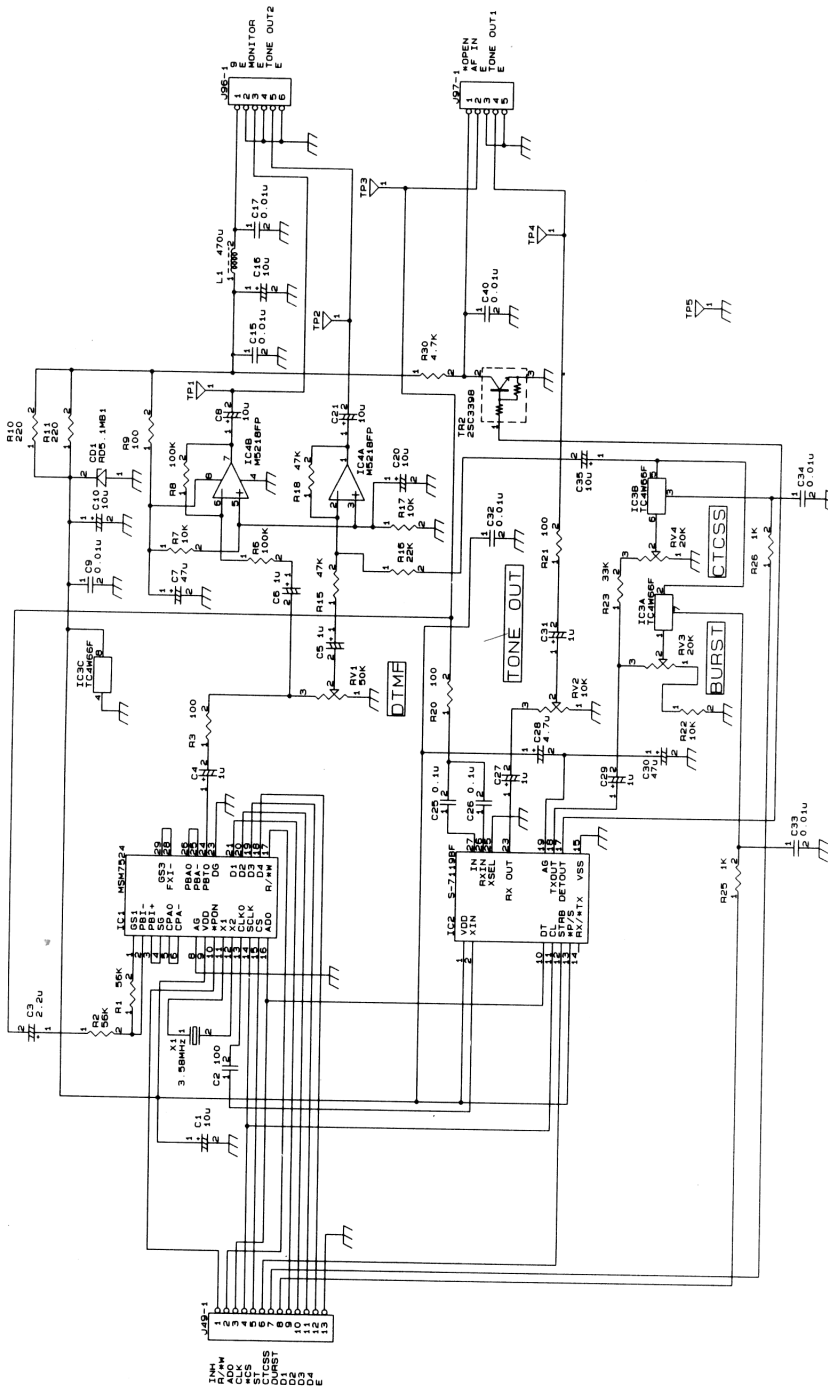

12.12 JST-145 Overall Connection Diagram (1/3)

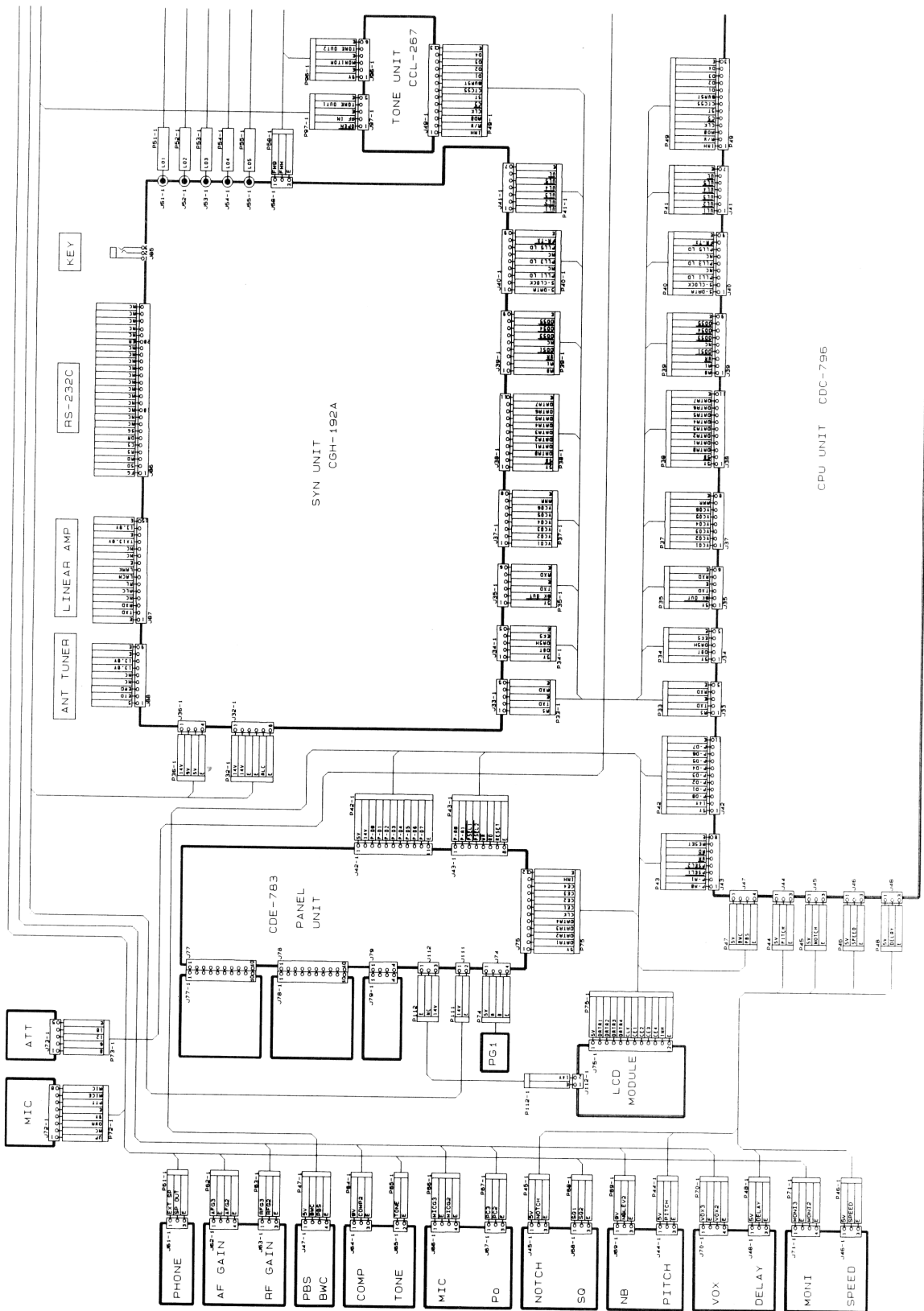

12.12 JST-145 Overall Connection Diagram (2/3)

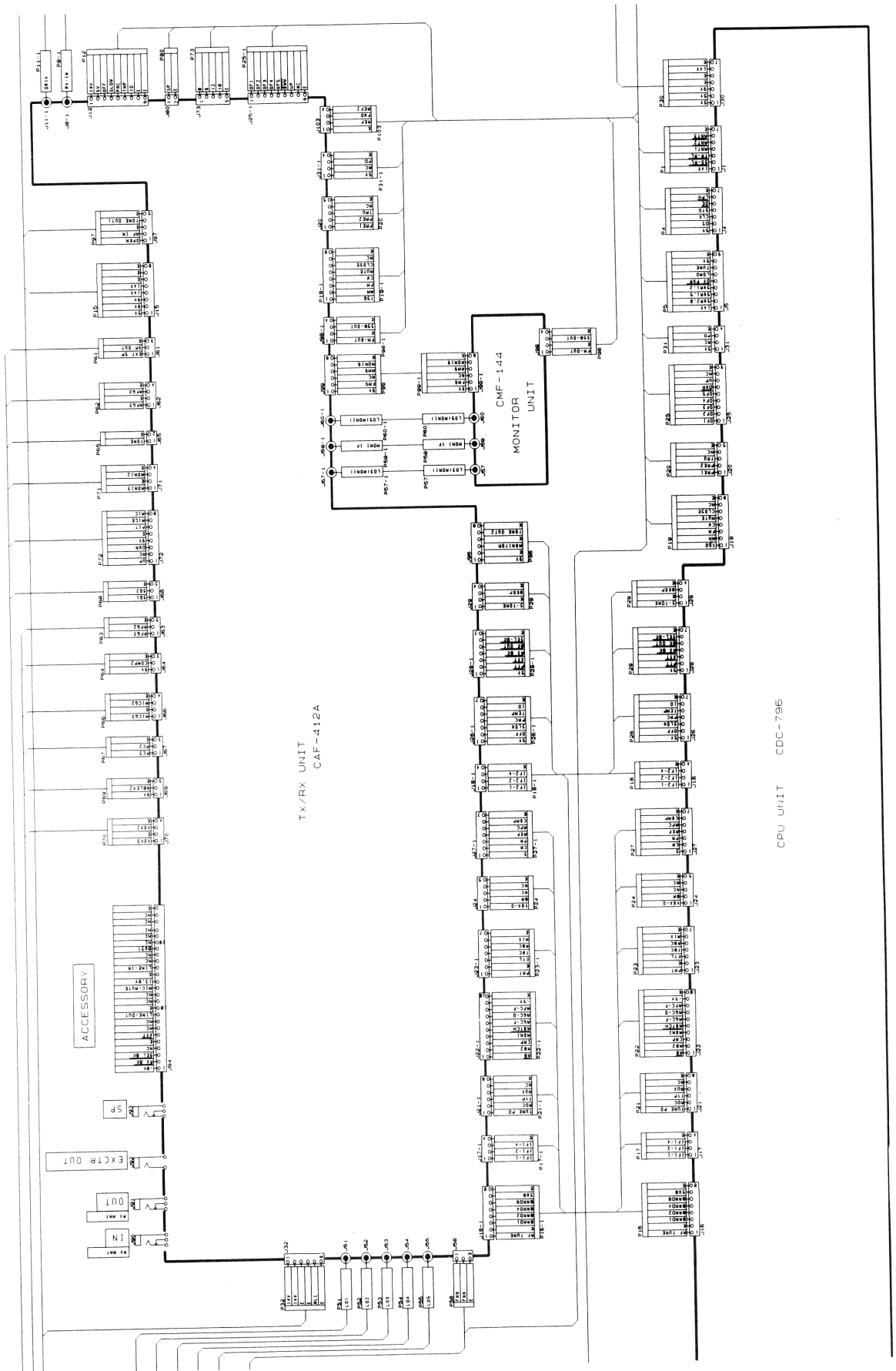

12.12 JST-145 Overall Connection Diagram (3/3)

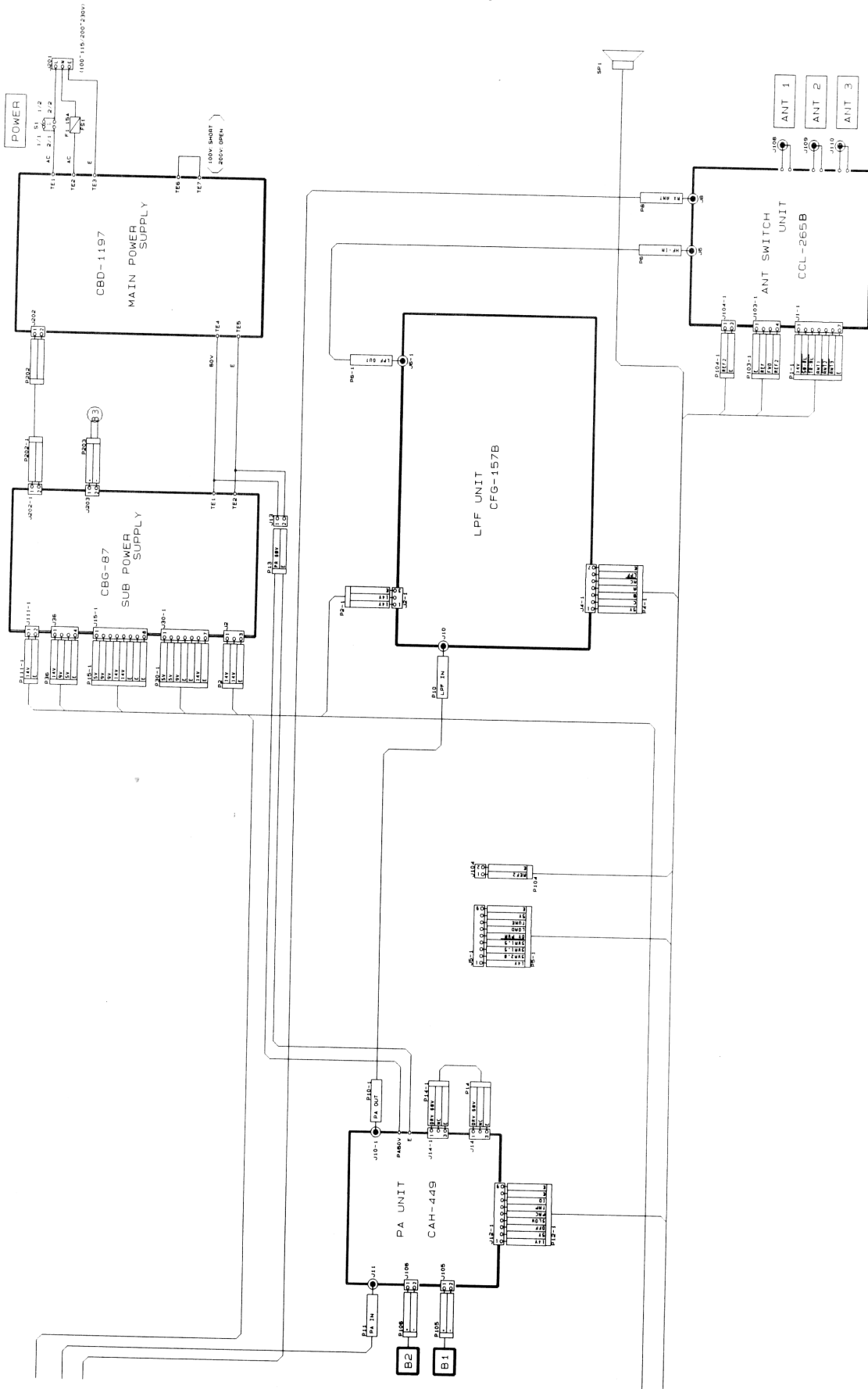

12.12 JST-245 Overall Connection Diagram (1/3)

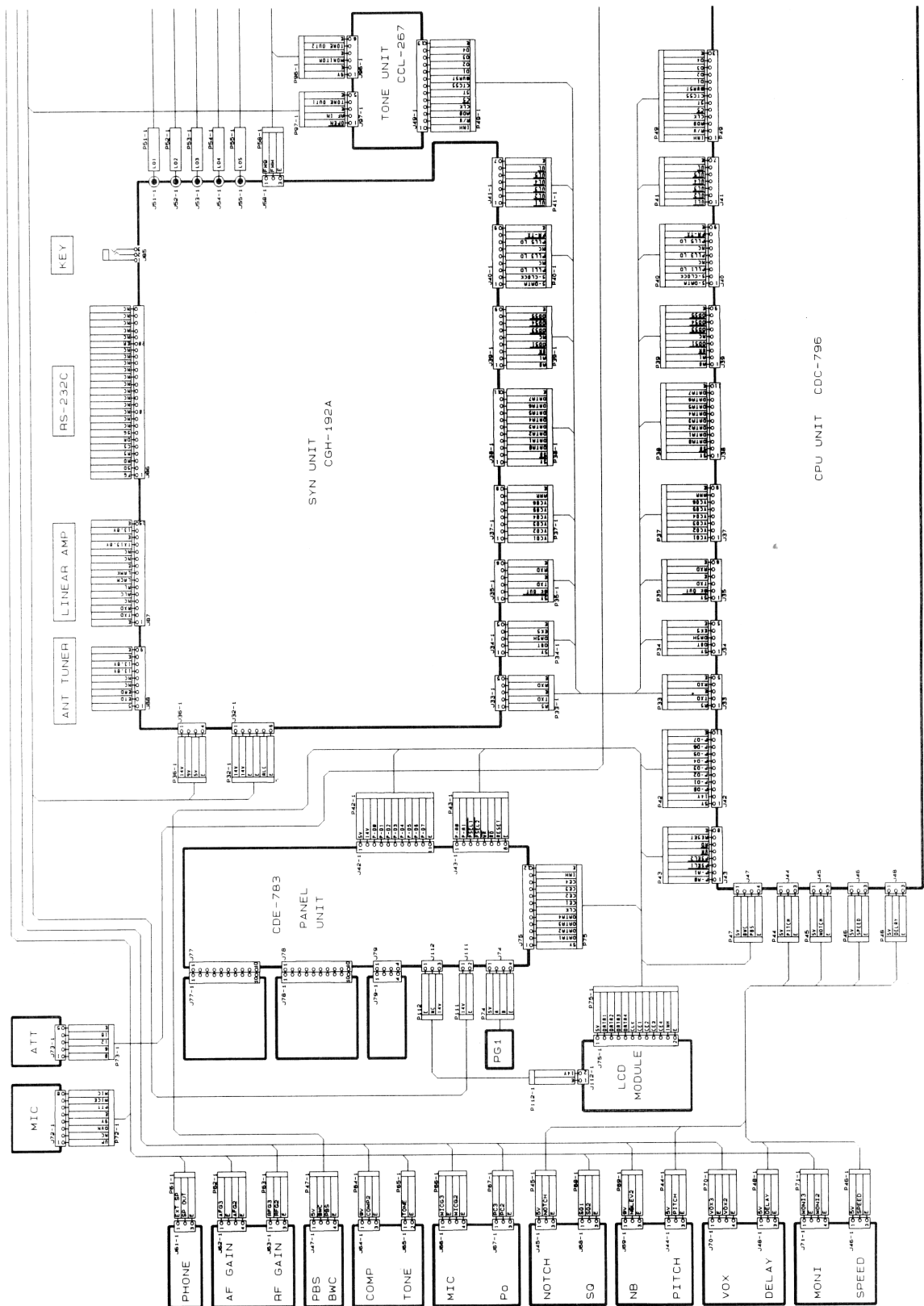

12.12 JST-245 Overall Connection Diagram (2/3)

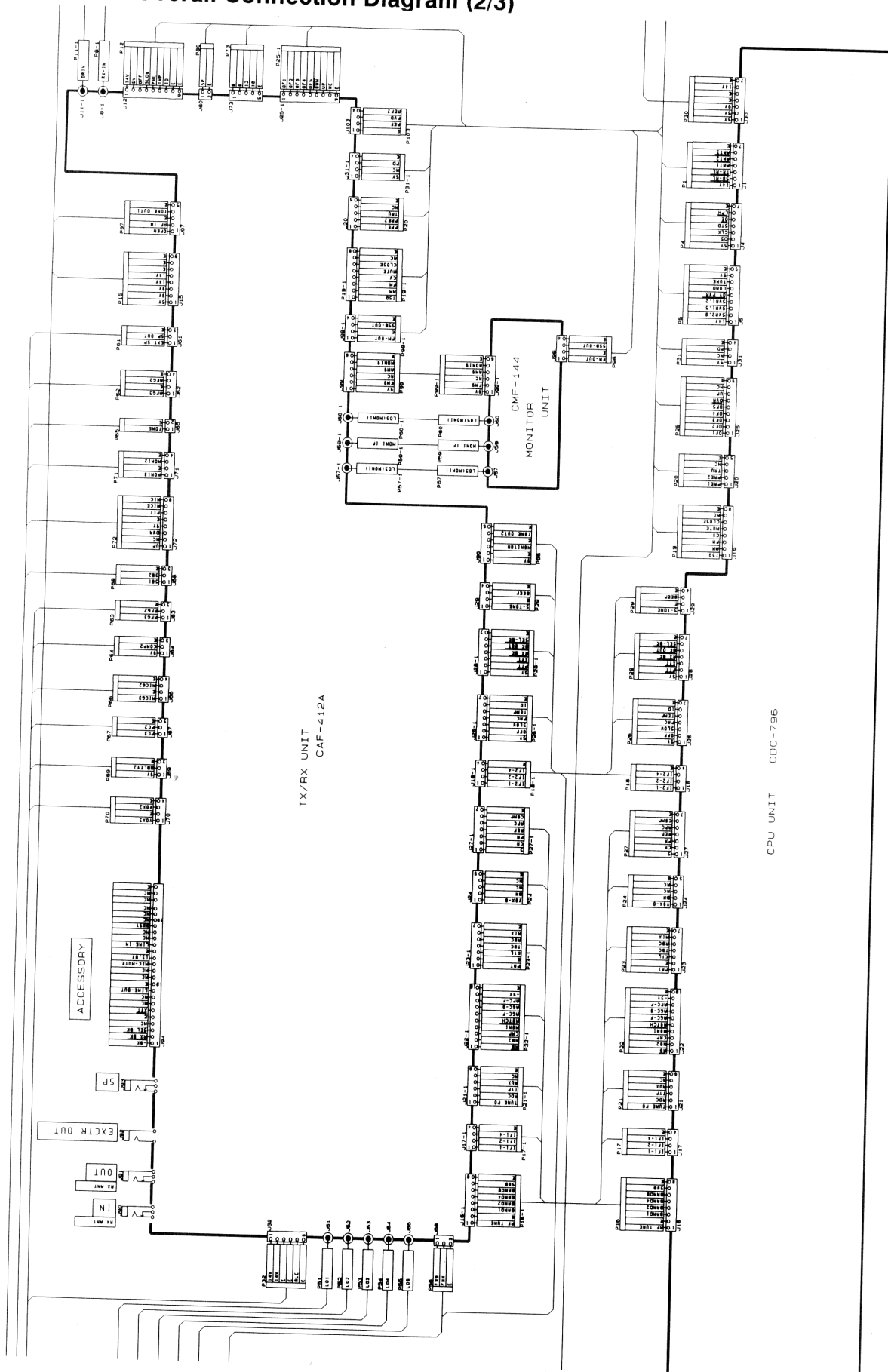

12.12 JST-245 Overall Connection Diagram (3/3)

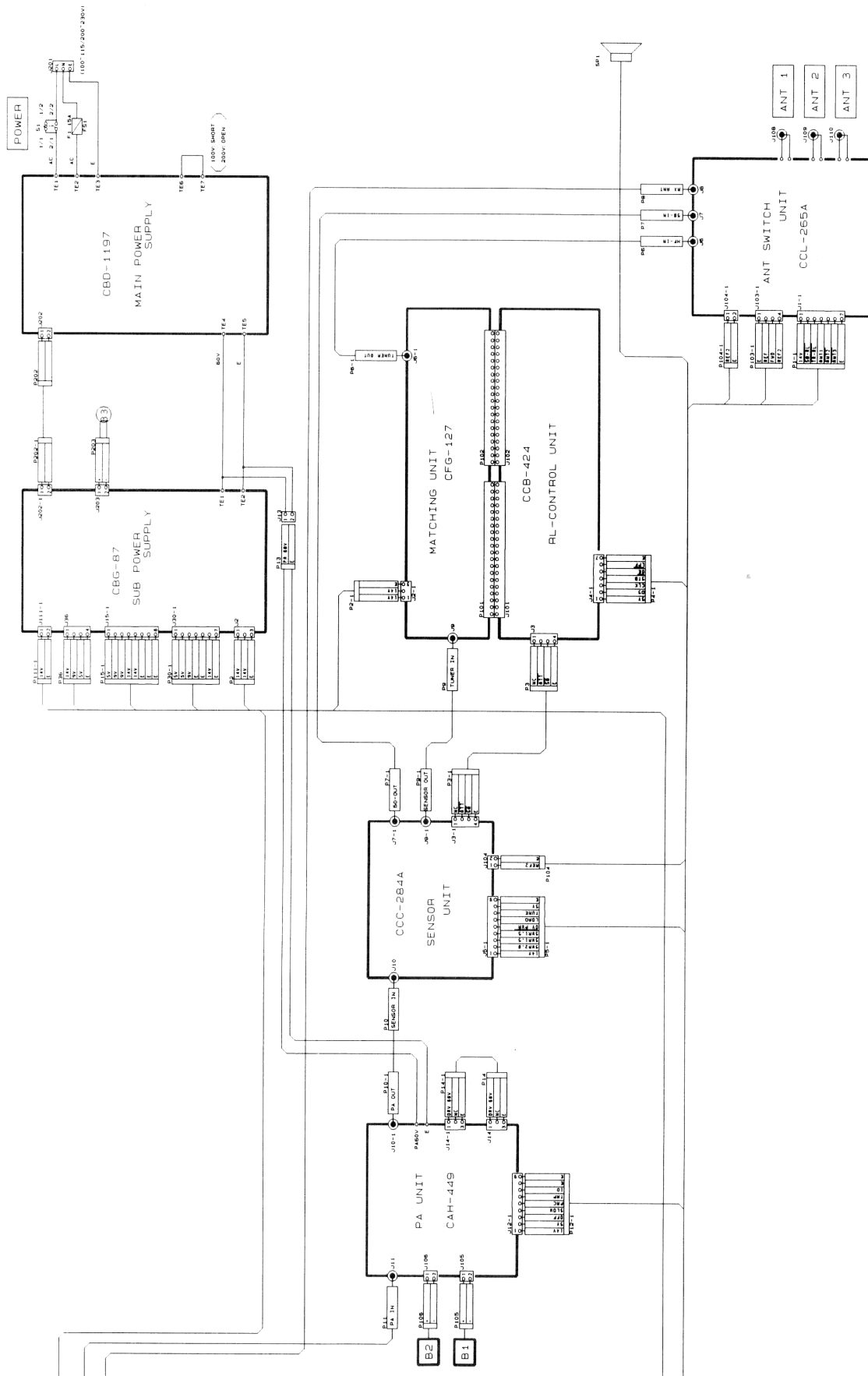

For further information, contact :



Since 1915

Japan Radio Co., Ltd.

Main Office : Akasaka Twin Tower(main),
17-22, Akasaka 2-chome,
Minato-ku, Tokyo 107, JAPAN
Phone : 03-3584-8837
FAX : 03-3584-8879

Overseas Branches : London, New York
Liaison Offices : Jakarta, Bangkok, Manila, New Delhi,
Hudson, Rio de Janeiro, Harlow,
Rotterdam, Las Palmas

AB '94.2(750)
No. 69159