



PLL-SYNTHESIZED COMMUNICATIONS RECEIVER

# NRD-515



# The Intelligent H

Again, a new communications receiver has come out from JRC having a history of 65 years in radio communications technology. The NRD-515, a successor to the NRD-505 that has won a high reputation, is a PLL-synthesized communications receiver of the highest class featuring the advanced radio technology combined with the latest digital technology.

The new receiver, NRD-515, is full of performance advantages including general coverage, all modes of operation, PLL digital VFO for digital tuning, 24-channel frequency memory (option), direct mixer, pass-band tuning, etc. JRC's radio communications technology of reputation will fully satisfy you and secure you long-distance communications all the world over.



**CHANNEL Switch**  
Selects a channel out of 24 channels stored in the memory.

**PRESET Indicator**  
Indicates preset reception mode.  
JRC — trademark

**Channel Display**  
Displays the channel number selected by CHANNEL switch.

**Receiving Frequency Display**  
Indicates a receiving frequency with a reading accuracy of 100 Hz on the 6-digit red LED readout.

**$\Delta$ F Indicator**  
Glowes when the  $\Delta$ F switch is set to ON.

**EXT VFO Indicator**  
Glowes when the VFO switch is set to EXT.

**S-meter**

**UP-DOWN Switch**  
Switch for the automatic quick tuning.

**TUNE Dial**  
Adjusts a tuning frequency, covering 10 kHz per revolution in 100 Hz steps.

**Graduated Sub-dial**  
Used for frequency reading with a graduation in 500 Hz increments.

**BFO & BC TUNE Control**  
Adjusts beat tone in CW reception and preselector tuning in AM medium frequency broadcast reception.

**MHz-Dial**  
Selects the MHz-digit of a receiving frequency.

**PHONES Jack**

**RF GAIN Control**

**Lock Button**  
Locks a tuning frequency electrically, and allows also calibration of the graduated sub-dial for the TUNE dial.

# NRD-515



# Rig is yours, for D





# DX in the 1980's.

Actual Size



- **MEMORY Button**  
Depressed to store a frequency in the memory.
- **PRESET/MANUAL Switch**  
Switch for selecting a frequency preset mode using the memory unit or the manual tuning dial.
- **ΔF Switch**  
Switches the ΔF circuit (RIT) to ON or OFF.
- **VFO Switch**  
Sets the receiver to operation by the external or internal VFO.
- **NB Switch**  
Switches the noise blanker to ON or OFF.
- **MONITOR Switch**  
Switches on/off the monitor for monitoring a transmitting signal from own station.
- **ATT Switch**  
Sets the antenna input attenuator to 10dB, 20dB and OFF.
- **POWER Switch**
- **ΔF Control**  
Used for fine adjustment of a receiving frequency without change of the indicated frequency on the display. In transceive operation, it is used as RIT.
- **BANDWIDTH Switch**  
Selects an IF filter out of four types, 6, 2.4, 0.6 kHz and an additional bandwidth.
- **PBT Control**  
Adjusts pass-band tuning, powerful for eliminating interference with adjacent frequencies in CW/SSB modes.
- **MODE Switch**  
Selects a receiving mode.
- **AGC Switch**  
Sets the AGC circuit to ON/OFF and switches over the time constants (FAST/SLOW).
- **AF GAIN Control**





# NRD-515

## PLL DIGITAL VFO

The heart of the receiver is the digital Variable Frequency Oscillator (digital VFO) consisting of a PLL synthesizer combined with a photo-type rotary encoder. The digital frequency synthesizer is phase-locked with a reference crystal oscillator, assuring outstanding frequency stability and accuracy. The digital VFO is designed for high reliability, having no mechanical parts and being free of backlash, reading error and secular variation. Moreover, the synthesizer has the main part housed in an aluminium die-cast case, ensuring rigid construction and high-quality circuit performance.



*Synthesizer unit*

## DIGITAL TUNING SYSTEM

The frequency tuning is very easy. The frequency is controlled by pulses that are generated by rotation of the tuning dial, such that one rotation of the dial covers 10 kHz in 100 Hz steps. The tuning system is provided with abundant functions, including UP/DOWN switch for automatic quick tuning, automatic band change by a tuning dial, electrical lock for preventing tuning frequency deviation due to vibrations or faulty operation, etc., ensuring fully continuous and rapid tuning.



*Rotary encoder*

## 24-CHANNEL FREQUENCY MEMORY UNIT (OPTION)

The NDH-515 is an optional frequency memory unit which is capable of storing up to 24 channels of frequencies. Memory manipulation and frequency change can be very easily performed by means of switches on the front panel. When a channel is selected by the CHANNEL switch, the receiver is automatically tuned to it for automatic reception.

The remarkably increased memory capacity allows you to perform sophisticated operations. The memory unit connector on the rear panel of the receiver is also used for frequency data input/output port, allowing extended application for control of a microcomputer or a peripheral device.

## CONTINUOUS COVERAGE, ALL-MODE RECEPTION

The receiver can continuously cover an extensive range of 100 kHz to 30 MHz and receive in any of the AM, LSB, USB, CW and RTTY modes. LF/MF bands below 1.6 MHz are clearly receivable through the use of a filter/tuning circuit. The receiving frequency is indicated down to the digit of 100 Hz based on the frequency control information of the synthesizer, ensuring high accuracy of frequency reading.

The analog sub-dial directly connected to the tuning dial permits reading of 500 Hz, giving convenience in QSY.

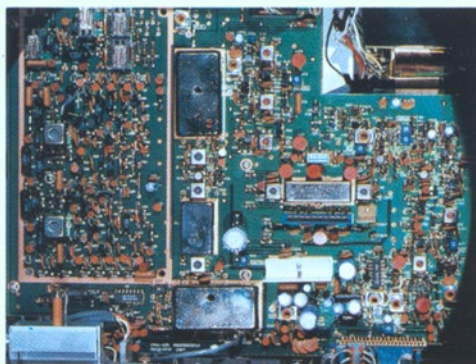

*Receiver unit*

## UP-CONVERSION TYPE DOUBLE SUPERHETERODYNE

The NRD-515 is an up-conversion type double superheterodyne receiver converting frequencies of 100 kHz to 30 MHz into the first intermediate frequency of 70.455 MHz. It features a direct mixer with a high-performance balanced mixer in the input stage at the front end, and a crystal filter in the 1st IF stage. All these add up to marked improvements on multi-signal and nearby-interference characteristics.

## EFFECTIVE PASS-BAND TUNING

IF filtering is switchable in 4 steps of bandwidth, 6 kHz, 2.4 kHz, 0.6 kHz (option) and AUX (option), irrespective of mode switching. A filter with 0.3 kHz or any desired bandwidth can be built-in in the AUX position. Moreover, passband

tuning is powerful in eliminating interference with adjacent frequencies in CW and SSB reception. In CW reception, any desired tone is receivable using a variable BFO.

## ELECTRONIC TUNING AND ELECTRONIC SWITCHING

Tuning and switching are electronically performed without any mechanical movement. The input filtering with automatic switching eliminates pre-selector tuning. This means simple construction, quick response, high reliability, and long life.

## ALL SOLID-STATE

All solid-state design using the newest semiconductors is another attractive feature of the NRD-515. They include low-power Schottky TTL IC's and CMOS IC's which contribute to reduced power consumption.

## COMPLETELY MODULAR CONSTRUCTION

The NRD-515 receiver is of completely modular design being composed of plug-in printed circuit boards for ease of servicing. The PC boards employ glass epoxy boards and fully automatic soldering, and inter-board connection is performed using a mother board. All this ensures uniform quality and improved reliability.

## EASY TO OPERATE, SMALL AND RUGGED

The front panel is designed for maximum ease of operation, using a light-touch tuning dial and making a rational layout of switches and controls on the panel.

The receiver is designed for small-size, lightweight and rugged construction with the front panel of die-casting. Thus, the enclosure satisfies tough environmental conditions.

## BUILT-IN ACCESSORY CIRCUITS

Provided are all the circuits and functions necessary for operation; pass-band tuning, a noise blanker, IF output terminal,  $\Delta F$  (RIT) circuit, 2-step switchable input attenuator, AGC 3-step switchover circuit, recording terminal, line output terminal, headphone terminal, AC voltage switchover, etc.

## OPERATION IN COMBINATION WITH THE NSD-505 TRANSMITTER

The NRD-515 has all the functions necessary for amateur station operation, such as VFO output, sidetone input, antitrip output, external VFO input, monitor ON-OFF, MUTE terminal, etc., which permit operation in combination with the NSD-505 transmitter.



## BLOCK DIAGRAM

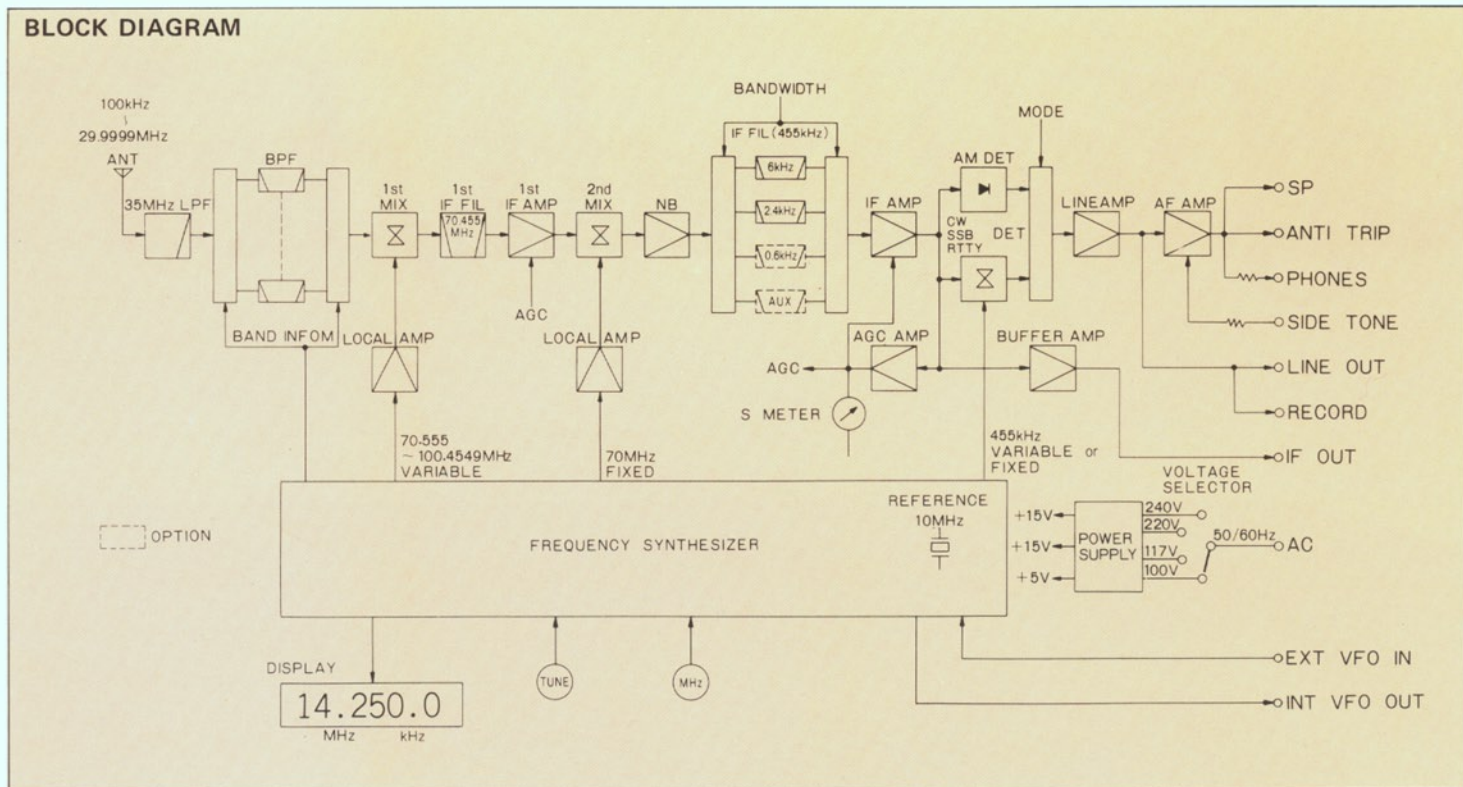

## SPECIFICATIONS

|                                  |  |                          |
|----------------------------------|--|--------------------------|
| <b>Receiving frequency range</b> | : 100kHz to 30MHz                            |                          |
| <b>Receiving modes</b>           | : RTTY/CW/USB/LSB/AM                         |                          |
| <b>Receiving system</b>          | : Double superheterodyne                     |                          |
|                                  | First IF                                     | 70.455 MHz               |
|                                  | Second IF                                    | 455 kHz                  |
| <b>Sensitivity (S/N: 10dB)</b>   | CW/SSB                                       | AM                       |
|                                  | 1.6 to 30 MHz                                | : Less than 0.5µV        |
|                                  | 100 to 1600 kHz                              | : Less than 2µV          |
| <b>Selectivity</b>               |  | : Less than 6µV          |
|                                  | 6kHz   | : 4kHz or more           |
|                                  | 2.4kHz                                       | : 2kHz or more           |
|                                  | *0.6kHz                                      | : 0.5kHz or more         |
|                                  | *0.3kHz                                      | : 0.26kHz or more        |
|                                  |  | : 10kHz or less          |
|                                  |  | : 6kHz or less           |
|                                  |  | : 3kHz or less           |
|                                  |  | : 2kHz or less           |
|                                  |  | * mark denotes option.   |
| <b>Frequency stability</b>       | : Less than 50Hz per hour after warming up.  |                          |
| <b>Image rejection ratio</b>     | : 70dB or more                               |                          |
| <b>IF rejection ratio</b>        | : 70dB or more                               |                          |
| <b>Input impedance</b>           | : 50 to 75 ohms, unbalanced                  |                          |
| <b>AF outputs</b>                | Speaker output                               | : 1W or more (4 ohms)    |
|                                  | Record/line output                           | : 1mW or more (600 ohms) |
| <b>Power requirements</b>        | : 100/117/220/240V AC, 50/60Hz, approx. 50VA |                          |
| <b>Dimensions</b>                | Height                                       | : 140mm                  |
|                                  | Width  | : 340mm                  |
|                                  | Depth  | : 300mm                  |
| <b>Weight</b>                    | : Approx. 7.5kg                              |                          |
| <b>Accessories</b>               | Instruction Manual                           | : 1 copy                 |
|                                  | M-type coaxial plug                          | : 1 pc.                  |
|                                  | Single-head plug                             | : 1 pc.                  |
|                                  | RCA plug                                     | : 4 pcs.                 |
|                                  | Square plug                                  | : 1 pc.                  |
|                                  | Fuse   | : 1 pc.                  |
|                                  | Pilot lamp                                   | : 1 pc.                  |

## DIMENSIONS (mm)

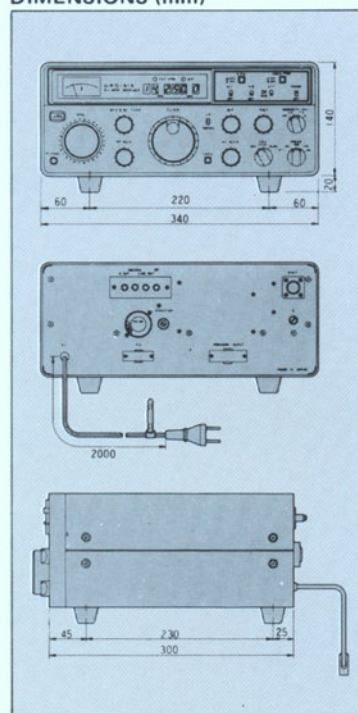

## OPTIONS

### • MEMORY UNIT NDH-515

The memory unit can be easily mounted on the receiver, into which the connecting cable connector must only be plugged in. The NDH-515 has a 24-channel capacity, allowing you to enjoy upgraded and sophisticated operation.

• Channels: 24 channels • Input/output data: 22-bit BCD code • Write-in: Voluntary • Dimensions: 340(W) x 50(H) x 200(D)mm • Weight: Approx. 3.5kg

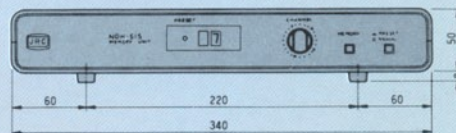

### • LOUDSPEAKER NVA-515

Beautifully finished to fit the design of the receiver. Clear and soft tone quality assured.

• Impedance: 4 ohms  
• Max. input power: 3W  
• Dimensions: 130(W) x 140(H) x 200(D)mm  
• Weight: Approx. 1kg

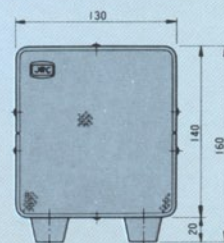

### • 600Hz FILTER CFL-260

Provides sharp selectivity, ensuring comfortable CW reception. Must only be plugged into the receiver unit.

### • 300Hz FILTER CFL-230

Provides sharp selectivity in CW reception, rejecting interference.

For further information contact:



**Japan Radio Co., Ltd.**

Since 1915

**Main Office:** Mori Building 5th,  
17-1, Toranomon 1-chome,  
Minato-ku, TOKYO 105, JAPAN  
Phone: Tokyo (03) 591-3451  
Telex: 02223068 JRCTOK J  
Cable Address: "JAPANRADIO TOKYO"

**Liaison Offices:** London, New York, Rio de Janeiro, Jakarta,  
Kuala Lumpur, Rotterdam, Las Palmas,  
Georgetown, Paramaribo