

VHF FM TRANSCEIVER

KT-220 ET/E/EE

INSTRUCTION MANUAL



KENPRO

TABLE OF CONTENTS

1. INTRODUCTION.....	1
1. 1. THANK YOU FOR YOUR PURCHASE.....	1
1. 2. INTRODUCTION.....	1
1. 3. ACCESSORIES AND OPTIONS.....	1
2. CONTROL FUNCTIONS.....	2
2. 1. CONNECTORS ON TOP PANEL.....	2
2. 1. 1. (1) ANTENNA CONNECTOR.....	2
2. 1. 2. (2) EXTERNAL MICROPHONE JACK.....	2
2. 1. 3. (3) EXTERNAL SPEAKER JACK.....	2
2. 1. 4. (4) EXTERNAL POWER CONNECTOR.....	2
2. 2. CONTROLS ON TOP PANEL.....	4
2. 2. 1. (5) VOLUME CONTROL AND POWER SWITCH.....	4
2. 2. 2. (6) SQUELCH CONTROL/TONE CALL SWITCH (***).....	4
2. 2. 3. (7) RF POWER SWITCH.....	4
2. 2. 4. (8) BATTERY INDICATOR / S-RF METER.....	4
2. 3. SIDE PANEL CONTROLS.....	4
2. 3. 1. (9) PTT (PUSH TO TALK) SWITCH.....	4
2. 3. 2. (10) LAMP SWITCH (Momentary).....	4
2. 3. 3. (11) KEYBOARD LOCK SWITCH / SUB-TONE DECODE.....	4
2. 4. FRONT PANEL.....	5
2. 4. 1. (12) SPEAKER.....	5
2. 4. 2. (13) MICROPHONE.....	5
2. 4. 3. (14) LIQUID CRYSTAL READOUT.....	5
2. 4. 4. (15) SOFT-TOUCH KEYBOARD.....	5
2. 4. 5. (16) BATTERY PACK.....	5
2. 4. 6. (17) RESET SWITCH ACCESS HOLE.....	5
3. PRE-OPERATING STEPS.....	6
3. 1. HOW TO CONNECT AN ANTENNA.....	6
3. 2. BATTERY PACK INSTALLATION.....	6
3. 3. TO USE RECHARGEABLE BATTERY PACK KT-BP2.....	6
3. 4. TO USE ALKALINE BATTERY PACK KT-BA2.....	6
3. 5. ATTACHMENT OF HANDSTRAP.....	7
3. 6. ATTACHMENT OF BELT CLIP.....	7
3. 7. WHEN NOT IN DAILY USE.....	7
4. OPERATION.....	8
4. 1. HOW TO RECEIVE.....	8
4. 2. HOW TO ENTER A FREQUENCY.....	8
4. 3. HOW TO TRANSMIT.....	9

4. 4. TOUCH-TONE® PAD FUNCTION(*).....	9
4. 5. CLOCK FUNCTION	9
4. 6. OFFSET VALUE SETTING	10
4. 7. SUB-AUDIBLE TONE ENCODER(*).....	10
4. 8. AUTO DIALER MEMORIES (*).....	11
4. 9. SCAN MODES FOR BAND SCANNING.....	12
4.10. STEP SIZE SELECTION FOR BAND SCANNING	12
4.11. UPPER AND LOWER LIMITS OF BAND SCAN	12
4.12. MEMORY USAGE	13
4.13. MEMORY RECALL	13
4.14. MEMORY WRITE (Storing Data)	13
4.15. MEMORY SCANNING	14
4.16. MEMORY SCAN MODES	14
4.17. SCAN LOCKOUT	14
5. SPECIFICATIONS	15
6. BLOCK DIAGRAM	16
7. TROUBLE SHOOTING HINTS	17
8. TECHNICAL SECTION	19

LIST OF FIGURES

1-1: UNIT AND ACCESSORIES.....	1
2-1: MICROPHONE SCHEMATIC.....	2
2-2: KT-220 CONTROL LOCATIONS	3
3-1: ATTACHING THE HANDSTRAP AND BELT CLIP	7
4-1: TONE CODE INPUT TABLE	10

NOTE (*) FOR KT-220ET (**) FOR KT-220E (***) FOR KT-220EE

1 INTRODUCTION

1. 1. THANK YOU FOR YOUR PURCHASE

Thank you for purchasing our model KT-220 , 2 meter FM handy transceiver. The KT-220 has been designed for easy use, however it is suggested that you read this instruction manual carefully for proper operation and best performance.

1. 2. INTRODUCTION

The KT-220 is a compact and light-Weight 2 meter FM handy transceiver with a PLL frequency determining system. The frequency range within which you can operate is from 144.00 to 147.995MHz (*/**), 144.00 to 145.995 MHz (***) with 5KHz steps; a total of 800 (*/**), 400 (***) channels can be selected by the Microprocessor controlled PLL frequency synthesizer.

Transmitter output can be set for either high (3 W) or low (500mW) power mode. In the low power mode, current drain is very low which helps to prolong the battery re-charge interval.

As the KT-220 contains a 5V regulated power supply circuit, it is stable against power voltage fluctuation, and operates in a wide voltage range between a minimum of 7.5Vdc and maximum 16Vdc. The unit is compactly designed in size and shape to fit your palm, and coupled with a light touch multi-function Keyboard and a full six digit LCD frequency and status readout to assure comfortable outdoor use. Many other optional accessories are available to expand the range of uses.

Fig. 1-1: ACCESSORIES AND OPTIONS

ACCESSORIES	DESCRIPTION	MODEL No.
1 KT-BP2 NI-CD BATTERY PACK (9.6V 250mAH)	FLEXIBLE ANTENNA	KA-144BH
1 KT-BC WALL CHARGER	LEATHERETTE CASE	KT-LC2
1 FLEXIBLE ANTENNA	BATTERY PACK	KT-BA2
1 BELT CLIP (WITH 2 SCREWS)	(FOR DRY BATTERIES)	
1 HANDSTRAP	NI-CD BATTERY PACK	KT-BPH
1 EXTERNAL MICROPHONE PLUG	(10.8V 450mAH)	
1 EXTERNAL SPEAKER PLUG	NI-CD BATTERY PACK	KT-BPS
1 EXTERNAL DC POWER PLUG	(13.2V 450mAH)	
1 EARPHONE	DESK TOP DUAL CHARGER	KCS-100
1 INSTRUCTION MANUAL	WALL CHARGER	KCS-200
	(FOR KT-BPH & KT-BPS)	
	MOBILE CHARGING CABLE	KT-BMC
	SPEAKER MICROPHONE	KT-SM1

1. 3. ACCESSORIES AND OPTIONS

1. Unpacking the carton of the KT-220, you will find the transceiver unit and its standard accessories as shown on page 1.

2 CONTROL FUNCTIONS

2. 1. CONNECTORS ON TOP PANEL

2. 1. 1. ① ANTENNA CONNECTOR

Connect the flexible antenna provided with the KT-220. Fit the connector tip of the antenna to the connector on the top panel then press and rotate it clockwise until it stops with a soft click. An external antenna can be used in the same manner as the flexible antenna. However due to the nature of the high-sensitivity and wide bandwidth of the front end circuitry a gain antenna of greater than 3 dB is not recommended.

2. 1. 2. ② EXTERNAL MICROPHONE JACK

When you wish to use an external microphone, connect it to this jack after wiring the supplied microphone plug with the microphone cable as shown in the schematic diagram. Or you may choose the optional speaker microphone model SM-1 from the optional accessories.

2. 1. 3. ③ EXTERNAL SPEAKER JACK

When you attempt to use an external speaker or an earphone, connect it to this jack. Use the supplied earphone plug to connect an external speaker. When this jack is used, the built-in speaker will not work but the external speaker or the earphone will operate instead.

2. 1. 4. ④ EXTERNAL POWER CONNECTOR

Power can be supplied from an external source to the transceiver using this connector. Voltage should not exceed the normal battery voltage found in an automobile. Internal battery condition or presence does not matter for this power source to operate properly. The battery is not charged while this source is being used unless the charger is also connected to the battery.

Fig. 2-1: MICROPHONE SCHEMATIC

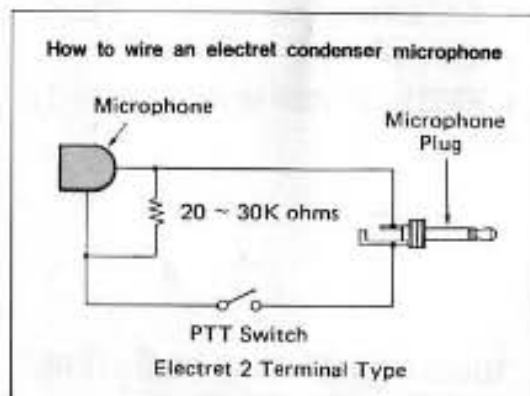
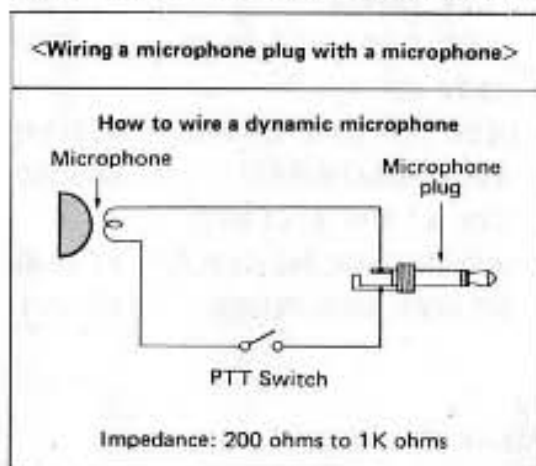

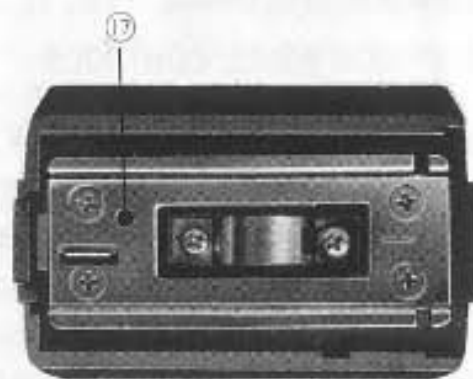
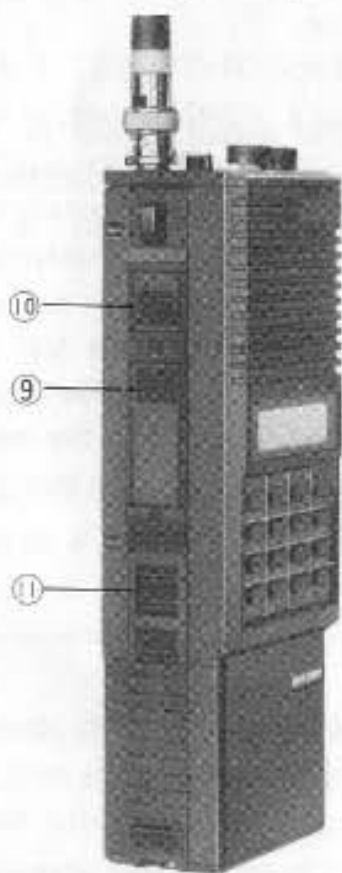
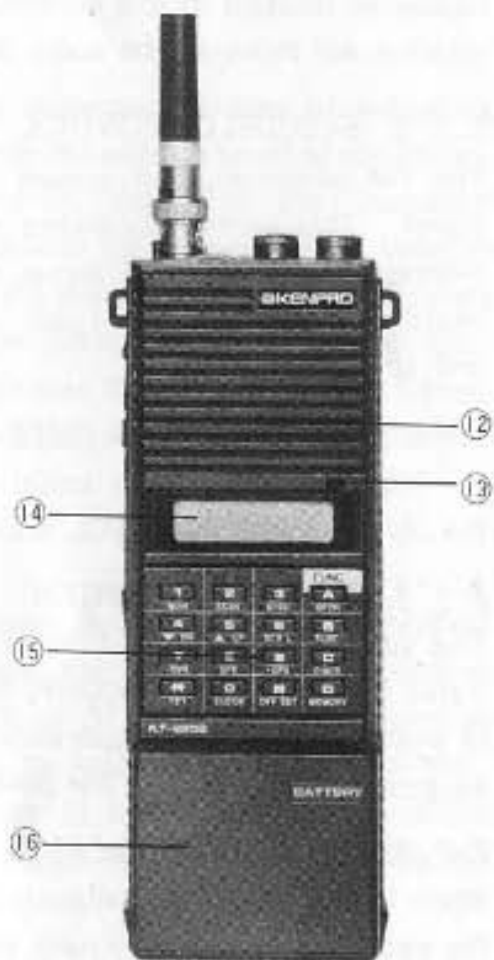
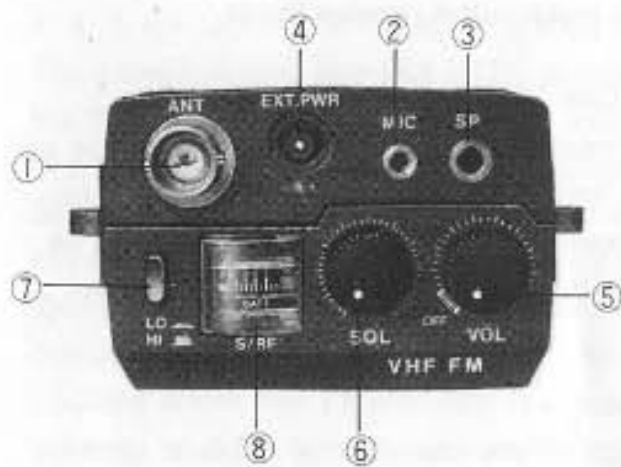

2. 2. CONTROLS ON TOP PANEL

2. 2.1. ⑤ VOLUME CONTROL AND POWER SWITCH

Clockwise rotation of this control will turn on the power. Further clockwise rotation will increase the audio output level in the receive mode.

2. 2. 2. ⑥ SQUELCH CONTROL / TONE CALL SWITCH (***)

The FM communication system generates a comparatively loud noise at no signal. This control squelches such noise in the receive mode. Counter-clockwise rotation at no signal will open the squelch and a noise will be heard. Clockwise rotation will close the squelch at the threshold level and shut off the noise.

TONE CALL SWITCH (KT-220EE only)

A 1750Hz Tone-burst for initial access of the repeater is needed, depress the ⑥ SQUELCH CONTROL knob for required period.

2. 2. 3. ⑦ RF POWER SWITCH

This selects the RF output power. In HIGH mode, the output power is 3 W (rated output), and LOW 500mW. In LOW mode, power consumption is decreased to enable long hours of operation. For short distance communication, it is suggested to operate on low power.

2. 2. 4. ⑧ BATTERY INDICATOR/S-RF METER

When the batteries are exhausted, the meter will be in the red and indicate the necessity of a battery pack exchange. In the normal TX position the meter will indicate the battery level. In the RX mode the relative level of the incoming signals is displayed.

2.3. SIDE PANEL CONTROLS

2. 3. 1. ⑨ PTT (PUSH TO TALK) SWITCH

This will change the mode to either transmit or receive. Depress it to operate in the transmit mode, and release to return to the receive mode.

2. 3. 2. ⑩ LAMP SWITCH (Momentary)

This switch lights the lamp located above the LCD readout for nighttime illumination. It is momentary and must be held down for the light to operate. The meter is also illuminated.

2. 3. 3. ⑪ KEYBOARD LOCK SWITCH/SUB-TONE DECODE ENABLE

This controls the entry of data via the KEYBOARD and also provides the capability to activate the optional CTCSS DECODER. The sub-Audible CTCSS ENCODER is a standard item on the KT-220ET and is unaffected by this switch.

2. 4. 1. ⑫ SPEAKER

In the receive mode, audio signal will be heard from this built-in speaker.

2. 4. 2. ⑬ MICROPHONE

This built-in microphone is an electret condenser type. In the transmit mode, talk into this microphone at a normal level of voice.

2. 4. 3. ⑭ LIQUID CRYSTAL READOUT

The Liquid Crystal Readout (LCD) provides a convenient means of indicating the status of the transceiver to the user under the widest variety of conditions. The LCD provides frequency information using six digits of the frequency beginning with the most significant and ending with the kilohertz digit. Memory channel number is provided on the left with the transmit and receive indicators located above and below the indication of the offset direction. Above the numbers is the scan status display which indicates the present mode of scan. Located above the TX indicator is the small 'E' error indicator and the 'M' memory or 'MW' memory write letters.

2. 4. 4. ⑮ SOFT-TOUCH KEYBOARD

The keyboard used is a conductive polymer over gold land type of keyboard using a soft-touch material for the contact with the finger doing the pushing. The sixteen keys of the keyboard do the work of 32 keys using the function key marked 'FUNC.'. There are no shift keys to hold down and when the function key is depressed the large 'F' appears in the display and indicates the next key pressed will be the function indicated in yellow letters below the key depressed.

2. 4. 5. ⑯ BATTERY PACK

The pack contains 8 Ni-Cd battery cells rated at 250 mA-hr. Instructions as to pack installation and replacement are given on page 6. Other battery packs are available for higher power and longer life for the KT-220.

2. 4. 6. ⑰ RESET | SWITCH ACCESS HOLE

Located in the battery anchor plate in the bottom of the main unit body is a small hole. Insertion of the proper tool will contact the reset switch which will cause the CPU to reset to its power up state. This must be done if the Lithium backup battery is changed. The program is in ROM and is not lost. Only the data in the memory locations is lost and may be easily re-inserted.

3. PRE-OPERATING STEPS

3. 1. HOW TO CONNECT AN ANTENNA

Transmitting for a short period on the KT-220 with no antenna connected should not damage the final transistor. However, you should always have an antenna connected for best results. The supplied flexible antenna or an external antenna can be connected.

Use a ground plane type having 50 ohm impedance or a 3 dB gain type antenna and connect it to the KT-220 with a BNC type plug. When used with an external antenna, the communication distance is extended.

3. 2. BATTERY PACK INSTALLATION

The KT-220 uses a slide-on/off battery pack for fast and easy replacement. JUST FOLLOW THE ARROWS ON THE REAR OF THE RADIO for installation or removal of the battery. When installing the battery, be sure the battery is pushed completely onto the radio. NEVER SHORT THE BATTERY TERMINALS AS DAMAGE TO THE BATTERY AND POSSIBLY FIRE AND INJURY COULD OCCUR. NI-CD BATTERY PACKS ARE CHEMICALLY STORED ENERGY.

PLEASE BE CAREFUL.

3. 3. TO USE RECHARGEABLE BATTERY PACK KT-BP 2

The KT-BP2 is a rechargeable battery pack and is attached to this model KT-220 as a standard accessory. The KT-BP2 has a charge jack, LED charge indication and reverse polarity protection circuit. When charging, use the KT-BC charger which is also included with this model as a standard accessory or equivalent charger to the KT-BC. If you wish to charge from the car battery source, please use the ST-MC mobile charging cord which is provided as an Optional accessory. Before operating, it is recommended to charge the KT-BP2 about 15 hours. Dead battery is indicated by the METER located on top of the unit while transmitting and the dimming of the LCD in receive and the word BATT appearing in the LCD display.

3. 4. TO USE ALKALINE BATTERY PACK KT-BA 2

The KT-BA2 will install/detach the same way as the KT-BP2 rechargeable battery pack. Remove the battery case as in the illustration, and install 6 alkaline batteries with the correct polarity. After installing alkaline cells in the KT-BA2, install the battery pack on the radio. When the meter shows red area it is time to replace the alkaline cells. NEVER RE-CHARGE ALKALINE CELLS. DO NOT DISPOSE OF IN FIRE.

3. 5. ATTACHMENT OF HANDSTRAP

A mounting hole is provided above the PTT switch on the left of the unit. If you wish to use the handstrap, apply the tip of the metal ring of the strap to this hole and attach by rotating it. See the illustration on page 7.

3. 6. ATTACHMENT OF BELT CLIP

If you wish to use a belt clip, attach it with the 2 screws provided on the rear panel as illustrated on page 7.

Fig. 3-1: ATTACHING THE HANDSTRAP AND BELT CLIP

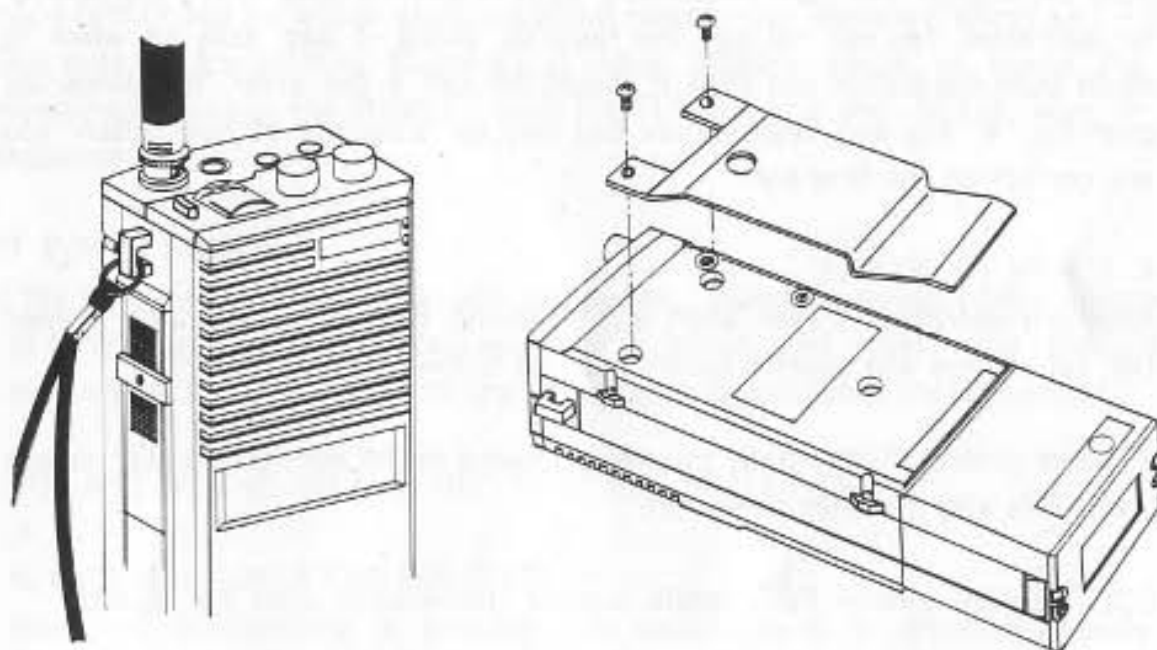

3. 7. WHEN NOT IN DAILY USE

When not in daily use, either leave the unit connected to voltage at the external power connector or leave a charged battery on the unit to conserve the lithium back-up battery. Store the unit with tone set to OFF (00).

When not using your radio, do not store it in a place where temperature or humidity is high.

Do not leave your radio in a car in the summer, as excessive heat may damage the plastic case or electronic components.

In winter time a drop in the temperature will decrease the battery capacity, and it may not perform at its best. In extremely cold temperatures, warm the transceiver under your coat before operating.

The batteries will be exhausted if the unit is left with the power switch turned ON. When not in use, be sure to turn it off.

4. OPERATION

To simplify operation, the KT-220 has a minimum number of controls and uses the easiest and most reasonable path to get the data to the transceiver for operation. You can not hurt the radio by giving it bad data so when in doubt push the button you think it should be and if the error 'E' comes up, push the '*' key and begin again. You may be surprised at how often you are correct on the first try!

4. 1. HOW TO RECEIVE

After pre-operation is over, start with receiving. Before turning the power ON, set volume and squelch controls at the following positions:

VOLUME control: Fully rotate counter clockwise to the minimum audio output level. This also switches power off.

SQL (squelch) control: Fully rotate counter clockwise to open the squelch.

1. How to Adjust Squelch Control

Turn on the POWER switch and rotate the VOLUME control knob clockwise. You will hear a harsh hissing noise or a QSO in progress. If a signal is received, wait for a clear channel or read the "How to Enter A Frequency" and enter frequency information until you find a frequency that is not being used where the hissing noise is heard.

Then adjust the squelch control. by rotating the SQL control knob clockwise, you will come to the point where this hissing noise suddenly stops. This is the threshold point of the squelch control.

The position of the SQL control knob determines at what level of radio signal the squelch will open. The more the knob is rotated clockwise, the less a weak signal can open the squelch.

4. 2. HOW TO ENTER A FREQUENCY

Clear the computer, just in case, by pushing the '*' button. Nothing should happen but the computer will be set for entry of data from the beginning. Key the frequency you wish to receive from the megahertz digit through the kilohertz digit and then PUSH THE '*' BUTTON.

EXAMPLE:

for 144.940MHz enter 494 *

or if you want to, 144940 * BUT DO NOT MIX PROCEDURES!

4. 3. HOW TO TRANSMIT

SIMPLEX OR DUPLEX MODE SET

When using a repeater station, push the FUNC/A key and the -DPX/7 key or the +DPX/9 key for either standard offset down (-) or standard offset up (+). This puts the transmitting frequency at either 600KHz above or below the receiving frequency. For SIMPLEX push the FUNC/A and the SPX/8 keys in sequence.

RF POWER SWITCH:

If the output level is sufficient with low power, place the power control button at LOW (depressed). Then depress the PTT switch, and make sure the TX appears on the LCD. Talk into the microphone to modulate the transmitter.

YOU ARE ON THE AIR ALREADY! THAT WAS REALLY EASY.

4. 4. TOUCH-TONE® PAD FUNCTION (*)

Now that transmitting is possible, the next step is to generate Touch-Tones®. While transmitting simply press one of the 16 keys and the corresponding set of DTMF tones will be heard at the receiving station. Anytime the unit is transmitting the entire keyboard is changed into a 16 Key DTMF generator.

4. 5. CLOCK FUNCTION

To look at the time of day clock push 'A', 'O'. To return to frequency push '*'. To set the clock push the time in 4 digits and then push 'A', 'O'.

For Example: 9:25 AM
Push 0 9 2 5 A 0

To get the accuracy to the nearest second, enter the number for the time not earlier than 55 seconds past the minute and press the 'A', 'O' sequence just as the time is 00 seconds on the reference.

4. 6. OFFSET VALUE SETTING

It is possible to set the value of the OFFSET to any value between 0000 and 9995 kHz in steps of 5 kHz. To change the standard OFFSET value, press the '*' button to make certain the computer is set to receive your data. Enter the OFFSET in kHz on the keyboard and press 'A', '#'. Now press '#' to read the OFFSET value to confirm the entry. ONLY OFFSETS ENDING IN '0' MAY BE STORED TO MEMORY.

Example: OFFSET VALUE is 1.020MHz.
in kHz this is 1020.

ENTER: 1 0 2 0 A # To write the data.

ENTER: # to read the entry.

The REPEATER frequency on 144.50 and 145.52 is used by entering the frequency for the RECEIVER, the OFFSET value and by using the +DPX setting for duplex. This entire sequence looks like this:

ENTER: 4 5 0 * 1 0 2 0 A # A 9

This puts the transceiver on 144.50 MHz with an offset of 1020 kHz and offsets the transmitter in the plus direction from receive. The transmit frequency should read 145.52MHz.

4. 7. SUB-AUDIBLE TONE ENCODER (*)

The sub-audible tone ENCODE function is a standard feature of the KT-220ET and is not an additional cost option. This unit is a computer controlled tone generator which uses information from the micro-processor to determine the frequency of the tone to be generated. To enter a tone into the tone generator register first key the '*' to prepare the processor for entry. key in the two digit code corresponding to the frequency desired from the chart and push the 'A', 'B' keys in sequence. To read the tone code in the register push only the 'B' key. To return to frequency push the '*' key.

Fig. 4-1: TONE CODE INPUT TABLE (KT-220ET only)

TONE	CODE	TONE	CODE	TONE	CODE	TONE	CODE
67Hz	64	94.8	28	131.8	19	179.9	10
71.9	32	100.0	27	136.5	18	186.2	9
74.4	62	103.5	26	141.3	17	192.8	8
77.0	31	107.2	25	146.2	16	203.5	7
79.7	60	110.9	24	151.4	15	210.7	6
82.5	30	114.8	23	156.7	14	218.1	5
85.4	58	118.8	22	162.2	13	225.7	4
88.5	29	123.0	21	167.9	12	233.6	3
91.5	56	127.3	20	173.8	11	241.8	2
						250.3	1

4. 8. AUTO DIALER MEMORIES (*)

The KT-220 microprocessor software contains the capability to store and automatically dial two separate seven digit numbers containing the digits 0-9 and the # and * tones. The A, B, C, D tones are not available in the autodial mode but may be used in 'overdial' after the autodialer is finished.

To read the numbers located in the autodialer memories press the 'C', key and either '1' or '2' to read either the first or second autodialer memory. This will appear initially as 0000000.

To write the telephone number into the autodial memory, press the '*' key to prepare the microprocessor for input. press the keys for the telephone number just as though you were dialing the number. After the seventh number press the 'A' key and then the 'C' key and either the '1' or '2' depending on which memory you want to use.

After the memory is written, on the next transmission the tones for that number will be sent without sidetone. At the end of the number the display will revert to the frequency of transmission. At this time you may continue to press the keys for additional tones or release the PTT switch to receive. For controllers which require that the auto-patch code be sent along with the number, place the auto-patch code and as much of the number as will fit and manually dial the balance before releasing PTT.

If it is desired to return to the frequency mode without dialing the number simply push the '*' key.

EXAMPLE 5 5 5 | 2 | 2 A C | puts 555-1212 in autodial #1.

To store the '*' or '#' key it is necessary to tell the processor you are using these keys for tones and not for programming the radio. This is done by keying 'C', '0' and then the number using the star or pound key. After this sequence is stored in an autodial memory the '*' key is depressed to return to frequency.

EXAMPLE C 0 # 1 * 2 # 3 0 A C 2 puts the sequence of # 1 * 2 # 3 0 into autodial memory #2.

To recall and use the numbers in autodial push 'C' 'X' where x= 1 or 2. To actually autodial a number, prepare the unit for transmit and then recall the number from C1 or C2. press and hold the PTT button and observe the display. The number is being dialed even as you watch! After the processor has finished the dialing process, it will return to the frequency display for transmit at

which time you may talk or continue to send tones by pressing the corresponding keys.

4. 9. SCAN MODES FOR BAND SCANNING

The KT-220 has four modes of scanning through the band of operation. Three of these are automatic and one is manual. All modes are selected by pressing the 'A' key and then another key from the top row to select the mode of scan desired. SearCH mode would be selected by pressing 'A', '3', while the OPEN mode would be elected by pressing 'A', 'A'.

The MAN mode flag will be on when the 'A', '1' keys are pressed. This means that each time the keys 'A', '5' are pressed in sequence, the frequency will go up one step and stop. If however the 5 key is pressed for longer than one second the frequency will begin to rapidly increase in steps set by the 'step size' sequence. It will not stop on a signal and must be stopped by pressing the PTT or the '*' button. If the 'A', '4' sequence is pushed the frequency will go down in the same manner but will stop only at the lower frequency edge of the band.

SCAN mode is probably the most popular of the band scanning mode as it prevents 'hang up' on a carrier that is always present, a birdie or the worlds most used repeating machine. Upon detecting a signal within the limits of the zero center detector, scan will pause for approximately 15 seconds to monitor the channel. It then will resume scanning.

SRCH mode of scanning is very useful for finding frequencies of operation in a certain area. After a signal of sufficient strength is located and it is determined to be close to frequency, scan will terminate and remain at that spot until commanded to resume.

OPEN mode of scan is the most common mode for other scanning type transceivers. This mode of scanning simply stays put on the channel after finding a signal until the signal goes away or becomes too weak to hold the squelch open.

4. 10. STEP SIZE SELECTION FOR BAND SCANNING

In addition to selecting the mode of scan the step size is also selectable in 5 kHz steps from 5 kHz to 100 kHz by pressing the keys for the desired step size and then pressing 'A', 'A'.

EXAMPLE: 15 kHz steps. 1 5 A A .

4. 11. UPPER AND LOWER LIMITS OF BAND SCAN

Bandscan can scan a selected portion of the band when the limits are set into Memory-0 for the upper limit and the lower limit is programmed into the dial. For this reason keep the highest frequency received in Memory-0 at all times. If an attempt is made to scan up from a frequency above this number the display will blink and no scanning will occur.

4. 12. MEMORY USAGE

The KT-220 contains 10 memory locations which can be used to store frequency, CTCSS tone, offset value and offset direction. EACH of the 10 Memories can store a full complement of different values for these parameters. The memories can also be scanned much in the same manner as the band can be scanned with the addition of the Priority feature for the 'SCAN' mode.

4. 13. MEMORY RECALL

To read the values from a memory into the operating register for use, press the 'D' to enter the Memory Mode. Confirm that this has been done by observing the LCD display in the upper lefthand area for a small 'M' which is always on during the Memory Mode. Next, press any of the number keys to recall the information in that memory number. It is not necessary to again press the 'M' key and in fact if you do so it will cause the readout to blank and the 'E' error sign to come on. Each time a different number key of '1' through '0' is pressed a different set of data is recalled. To exit the Memory Mode the '*' key is pressed which returns to the frequency entry mode with the memory data in the operating position.

4. 14. MEMORY WRITE (Storing Data)

To store information in the memory all of the individual registers must have been set to the correct value. This may have been done by the user or the pre-programmed values may be used. The pre-programmed values for the offset are 600 kHz and the tone is 'off' meaning a value of '00' is stored.

EXAMPLE: 4 9 4 * A 7 A D I

This will store 144.940 receive into memory one with a minus 600 kHz offset. Note that as the keys are depressed the values appear in the LCD display. As the '*' is depressed the full six digit readout is displayed. When the 'A' key is depressed the 'F' symbol is displayed to indicate the next key will be a function. As the '7' key is depressed the minus symbol '-' appears in the display to indicate the offset has been chosen as minus. Again pressing the 'A' key causes the 'F' to appear and as the 'D' key is pressed the symbol 'MW' for memory write appears. The next key pressed must

be a number 0-9 key. The frequency, offset, offset direction and the CTCSS tone registers are stored in that MEMORY. The 'MW' disappears and the unit is ready for additional input. One note however, the memory locations area for offset can store any offset which ends in 0. If an offset ending in 5 is needed it is available using the entry register. A word of caution however, the ending 5 must be reset to zero by the user or it will remain in the operating register even if a new frequency is entered and the default offset is used. In other words if you use an offset like 1005 and enter a new frequency the offset will default to 600 khz but the 5 will remain for a value of 605 kHz.

4. 15. MEMORY SCANNING

The KT-220 is capable of scanning memory in several very useful modes of scan or skipping a particular memory altogether. In addition a pseudo-Priority system which treats Memory-1 differently from the rest is also available.

Enter Memory Mode with '*', 'D' keys.

4. 16. MEMORY SCAN MODES

MANual mode is just that. If commanded the unit will step to the next memory location manually or if the key is held will scan all without stopping. Activate with 'A', '1', 'A', '5' when in memory mode.

SCAN mode is the most popular mode as the memories are all scanned in order as expected except for Memory-1 which is treated as a higher priority channel and scanning will stop here for as long as there is a signal present. All other channels of memory are scanned delete unless the 'SCNL' flag is set in which case that memory is skipped. When a signal is found the scan pauses for 5 seconds and after the expiration of this time steps to Memory-1 to check for a signal. If no signal is present on Memory-1, the scan resumes at the next channel past the previous stopping point. For example, if Memory-5 is busy the scan will pause for 5 seconds after which Memory-1 is sampled. If Memory-1 is not busy then scan resumes checking at Memory-6. Should Memory-1 be busy then scan will be suspended until it becomes open. Scan will resume at Memory-6 after Memory-1 is open for 3 seconds. Activate with 'A', '2', 'A', '5' KEYS.

SRCH mode simply looks for the first occupied Memory and stops scanning on that frequency. If the SCNL flag is set the scan will not stop there. Activate with 'A', '3', 'A', '5' keys.

OPEN mode scanning checks all Memories not set with the SCNL flag and stops on an occupied channel until it has been un-occupied for 3 seconds. Activate with 'A', 'A', 'A', '5' keys.

4. 17. SCAN LOCKOUT

Anytime it is desired to skip a Memory during scanning, press the 'A', '6' keys in sequence while that memory is displayed in the LCD. This will prevent the scan from stopping on the channel no matter what its condition, occupied or un-occupied. The data in the memories is un-affected by this flag and may be recalled by the Memory recall procedure. Memory-0 may not be flagged for SCNL.

5. SPECIFICATIONS

SPECIFICATION 2 METER TRANSCEIVER MODEL KT-220

* GENERAL	
FREQUENCY RANGE	144.000 - 147.995MHz (*/**) 144.000 - 145.995WHz (***) additional ranges available
TYPE OF EMISSION	16F3 (5 KHz DEVIATION FM)
MEMORY CHANNELS	10 CHANNELS FOR FREQUENCY, OFFSET, CTCSS TONE, AND SCAN LOCKOUT.
ANTENNA IMPEDANCE	50 OHMS
POWER SOURCE	9.6 Vdc Ni-Cd BATTERY PACK. 9 Vdc DRY BATTERY PACK EXTERNAL D.C. CONECTOR 8.4-16Vdc
* TRANSMITTER	
RF POWER OUTPUT	3.5 WATTS HIGH POWER AT 9.6 Vdc 5 WATTS HIGH POWER AT 13.2 Vdc 0.5 WATTS LOW POWER AT 9.6 Vdc
MODULATION	DIRECT FM OF PLL
MAXIMUM DEVIATION	+/- 5 kHz
TRANSMIT SPURIOUS	AT LEAST -60 dBc
MICROPHONE	ELECTRET CONDENSER MICROPHONE
* RECEIVER	
RECEIVING METHOD	DOUBLE SUPERHETERODYNE
INTERMEDIATE FREQUENCY 1.	16.9 MHz
2.	455 kHz
SENSITIVITY	BETTER THAN 0.25 uV AT 12 dB SINAD
BANDWIDTH	+/- 7.5 kHz AT 6 dB DOWN
SELECTIVITY	+/- 15 kHz AT 60 dB DOWN
AUDIO OUTPUT AVAILABLE	400 mW AT 8 OHMS

6. BLOCK DIAGRAM

BLOCK DIAGRAM

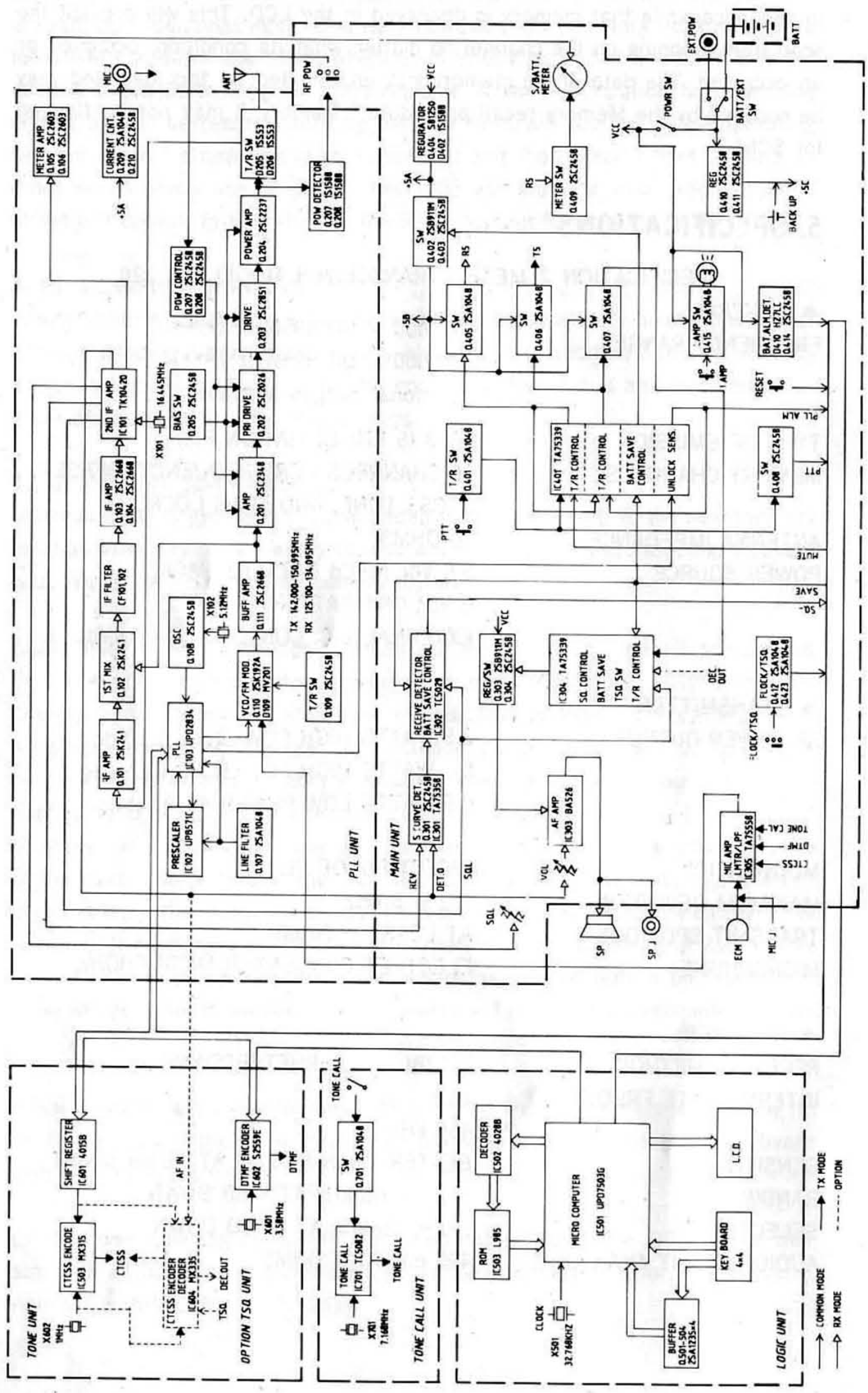

7. TROUBLE SHOOTING HINTS

PROBLEM	POSSIBLE CAUSE	POSSIBLE SOLUTION
NO READOUT OR POWER NO SOUND	BAD POWER PACK REVERSED CELL IN PACK DRY CELLS EXHAUSTED	CHECK CONNECTION OF PACK OR REPLACE PACK REPLACE CELLS
NO SOUND FROM SPEAKER	VOLUME IS DOWN UNIT IS IN TX MODE TOO MUCH SQUELCH EXTERNAL PLUG BAD BATTERY IS DEAD	TURN UP VOLUME CHECK DISPLAY FOR TX PUT IN RX MODE ROTATE SQ COUNTER CLOCKWISE REPLACE PLUG OR JACK REPLACE BATT PACK
POOR SENSITIVITY BUT STILL RX ON STRONG SIG	BAD FLEX ANTENNA OR CONNECTOR IN RADIO ANTENNA LINE IS BAD	REPLACE ANTENNA REPLACE CONNECTOR REPLACE EXT ANTENNA FEEDLINE
NO OR LOW RF OUTPUT	RE SWITCH IN LOW LOW OR DEAD BATTERY ANTENNA OR CONNECTOR	RESET TO HI REPLACE BATTERY REPLACE AS NEEDED REPLACE AS NEEDED
NO MODULATION	BAD CONNECTION ON MIC NO VOLTAGE ON MIC	REPAIR CONNECTOR REPAIR SOURCE OF VOLT REMOVE SHORT FROM MIC

- A**
ALKALINE PACK KT-BA, 6
ANTENNA CONNECTION, 5
ANTENNA CONNECTOR, 2
- B**
BANDSCAN
CARRIER (OPEN), 12
MANUAL, 12
SCAN PAUSE, 12
SEARCH, 12
STEP SIZE SETTING, 12
BANDSCAN UPPER
LOWER LIMIT SETTING, 12
BANDSCANNING, 12
BATTERY LEVEL INDICATOR, 4
BATTERY PACK, 5
BATTERY PACK INSTALLING, 6
BATTERY PACK RECHARGE, 6
BELTCLIP ATTACHMENT, 6
- C**
CLOCK, 9
- E**
ENTER A FREQUENCY, 8
EXTERNAL MIC JACK, 2
EXTERNAL POWER JACK, 2
EXTERNAL SPEAKER JACK, 2
- H**
HANDSTRAP ATTACHMENT, 7
HOW TO TRANSMIT, 9
HOW TO USE AUTODIALER, 11
HOW TO USE MEMORY, 13
HOW TO USE SUB-AUDIBLE
ENCODER, 10
- K**
KEYBOARD LOCK SWITCH, 4
- L**
LAMP SWITCH, 4
- M**
MEMORY
CARRIER(OPEN), 14
SCAN, 14
SCANNING, 14
SEARCH, 14
WRITE, 13
MEMORY RECALL, 13
MEMORY SCAN
LOCKOUT, 15
MEMORY SCAN MODES, 14
MEMORY USAGE, 13
METER, 4
- O**
OFFSET VALUE CHANGE, 10
OPERATION, 8
- P**
POWER SWITCH, 4
PTT SWITCH, 4
- R**
RECEIVE LEVEL INDICATOR, 4
RECEIVING, 8
RESET SWITCH ACCESS, 5
RF SIGNAL LEVEL INDICATOR, 4
RF POWER SWITCH, 4
- S**
SPECIFICATIONS, 15
SQUELCH CONTROL, 4
STORAGE, 7
SUB-AUDIBLE DECODE SWITCH, 4
- T**
TOUCH-TONE PAD, 9
- V**
VOLUME CONTROL, 4

KT-220ET/E/EE SCHEMATIC DIAGRAM - 1-

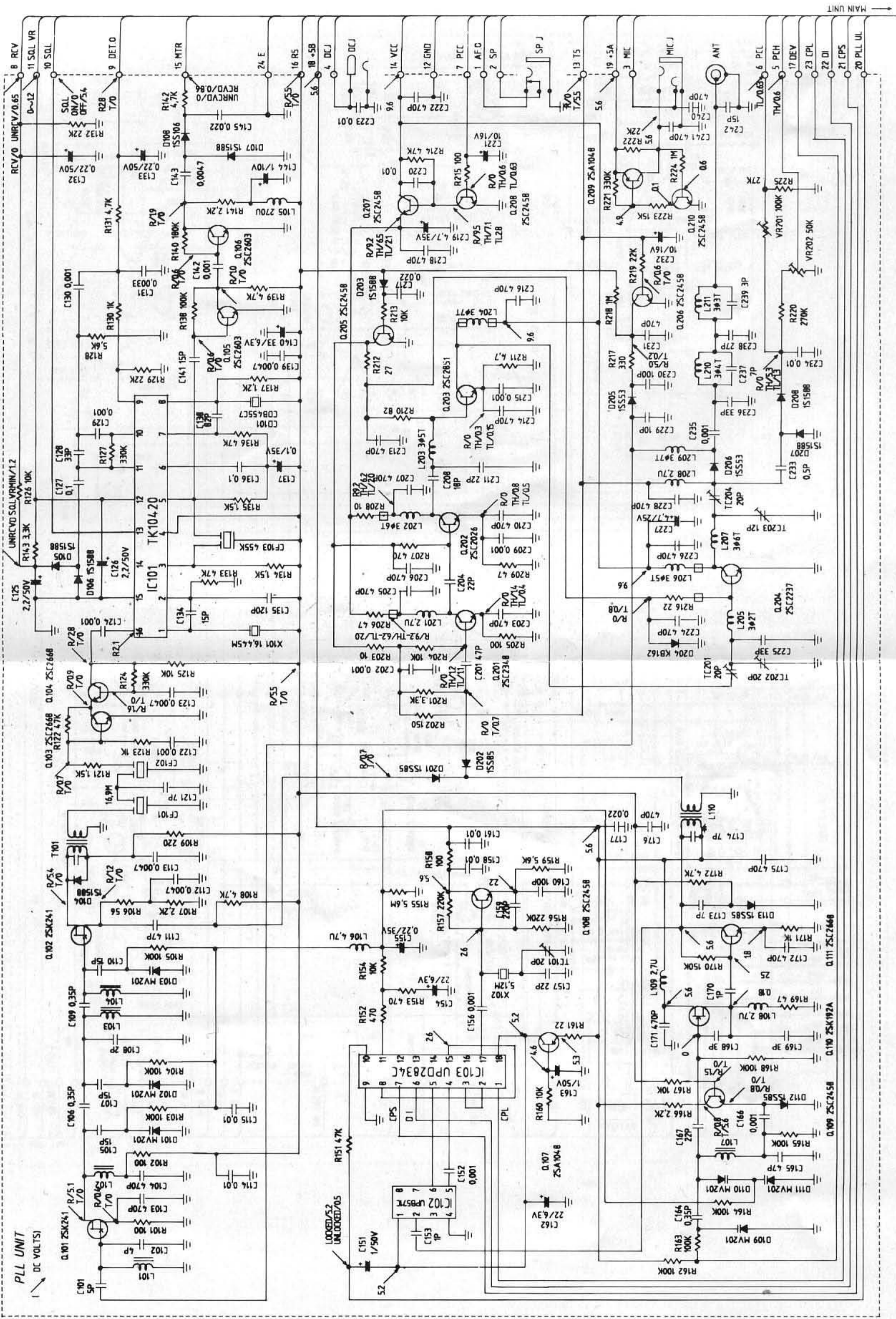

Downloaded by RadioAmateur.EU

KT-220ET/E/EE SCHEMATIC DIAGRAM-2-

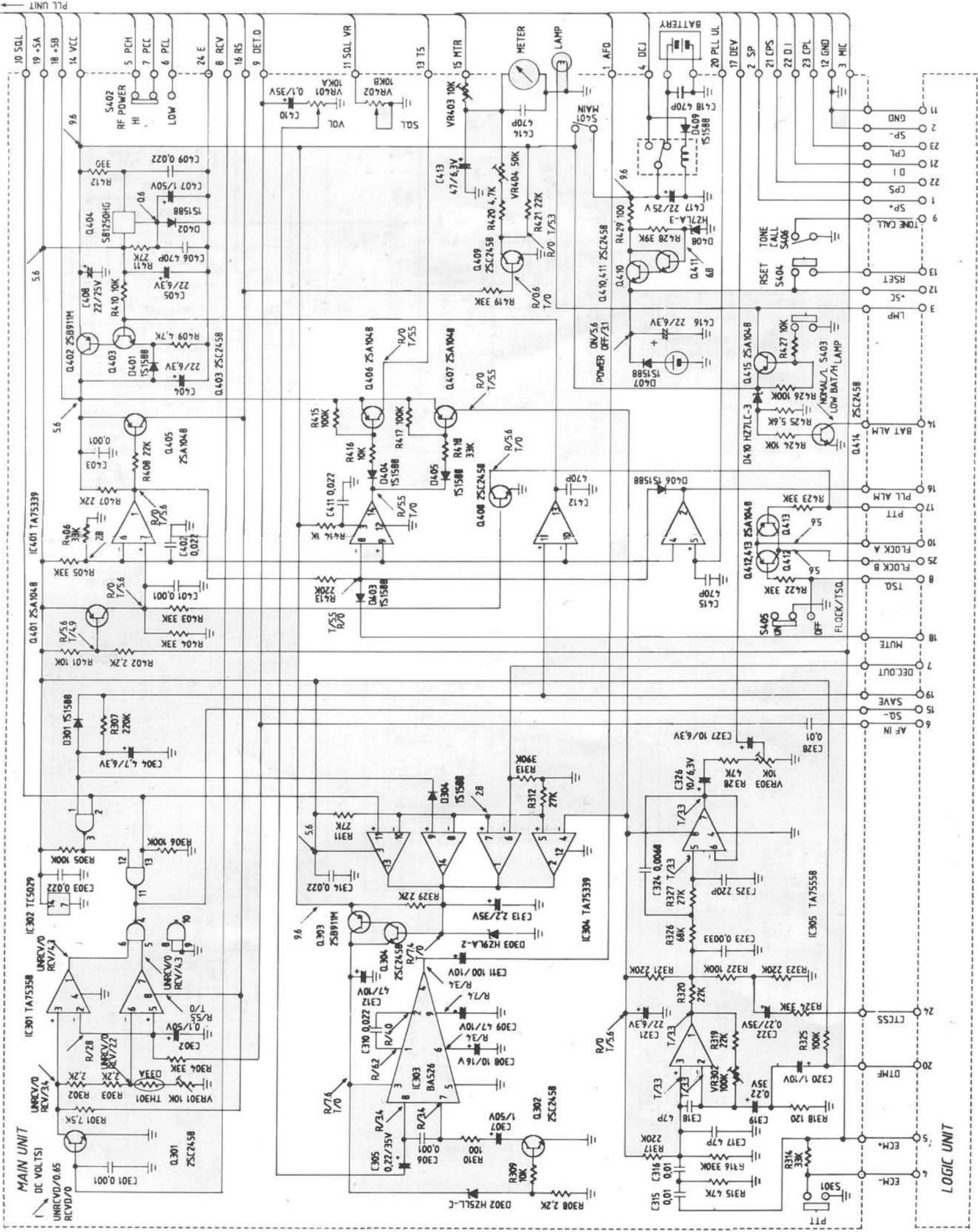

LOGIC UNIT

MAIN UNIT

KT-220ET/E/EE SCHEMATIC DIAGRAM-3-

LOGIC UNIT (DC VOLTS)

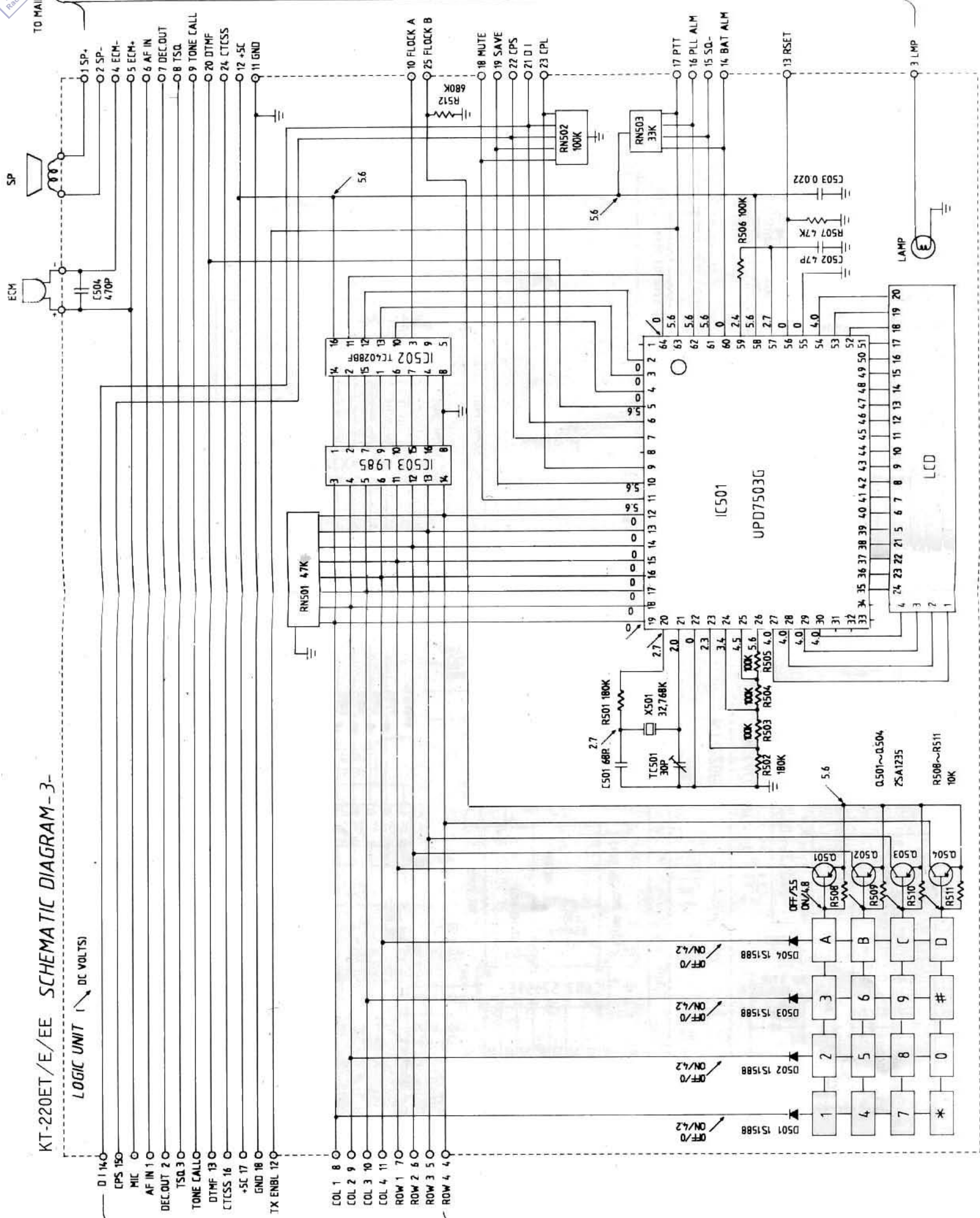

TONE UNIT

(DC VOLTS)

KT-220ET

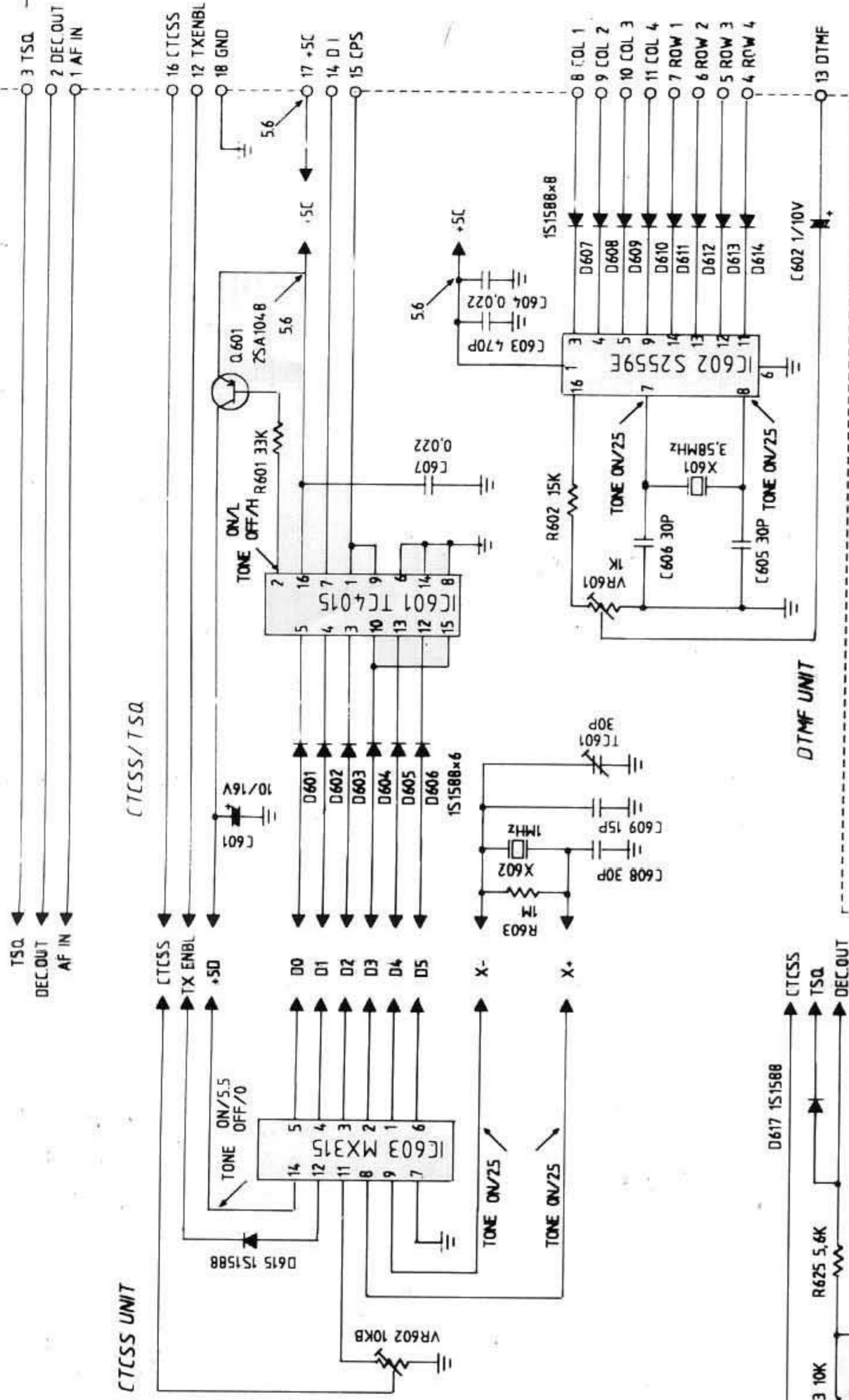

OPTION

TONE SQL UNIT

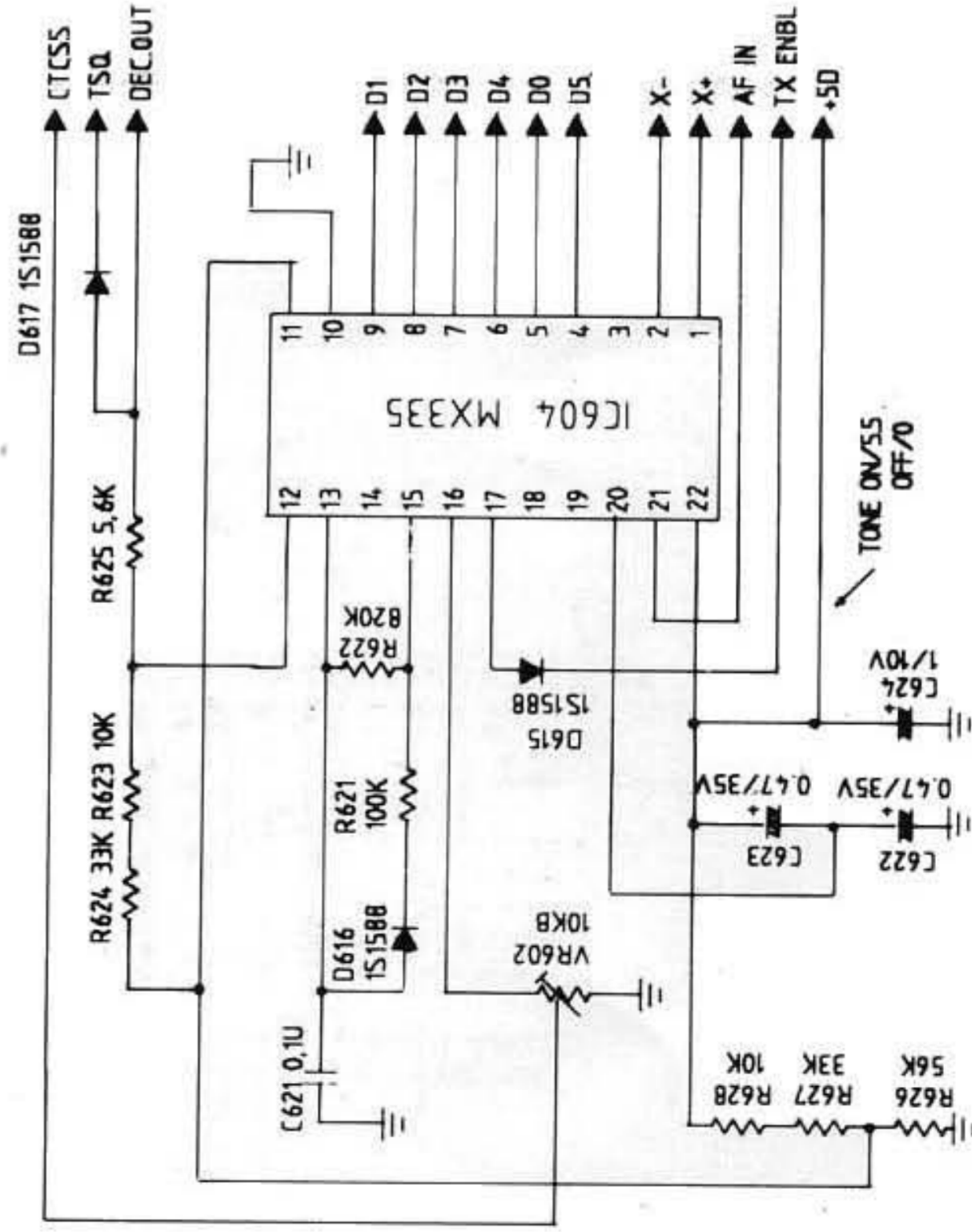

KT-220EE

TONE CALL UNIT

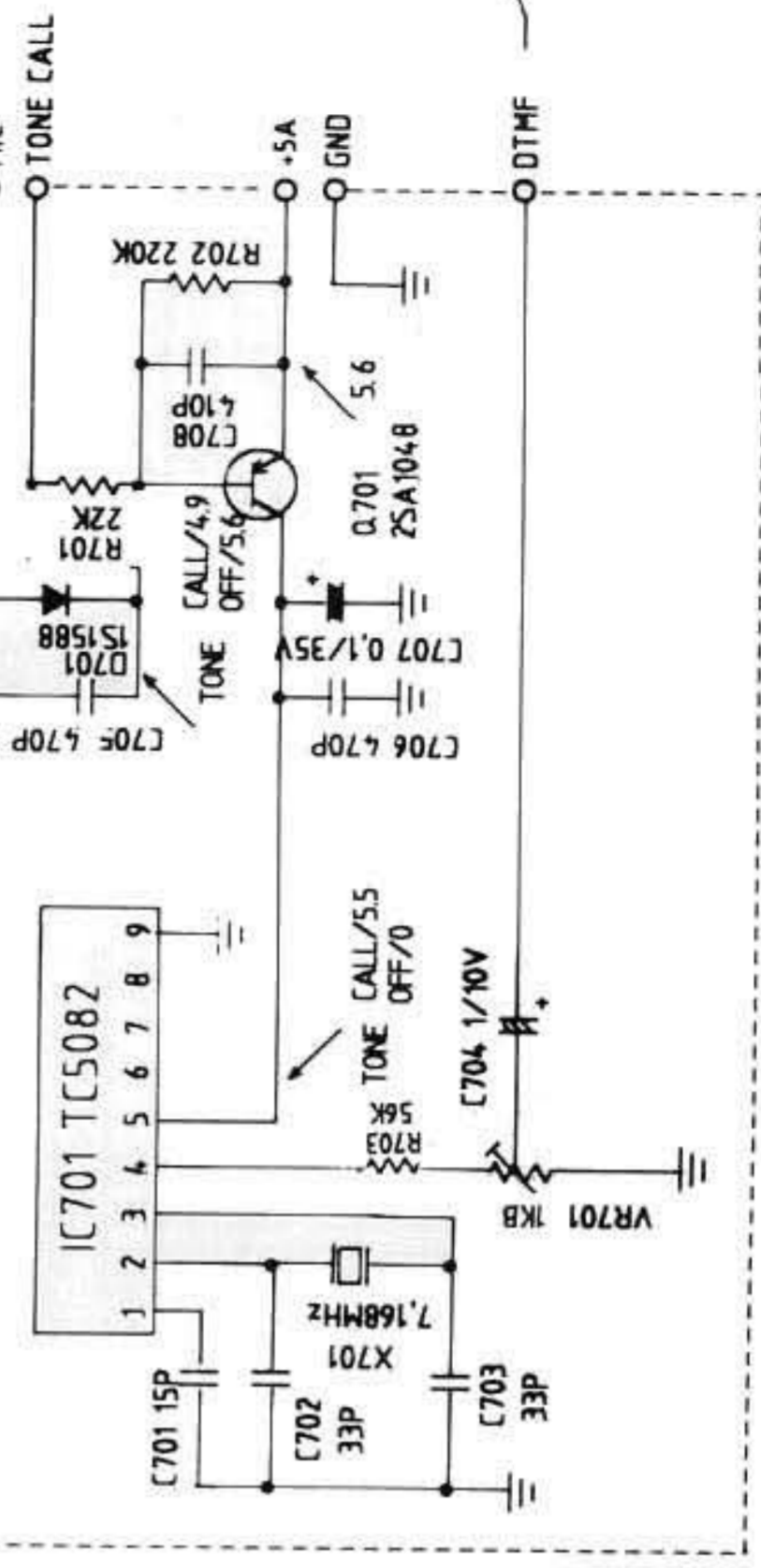

PLL UNIT-1

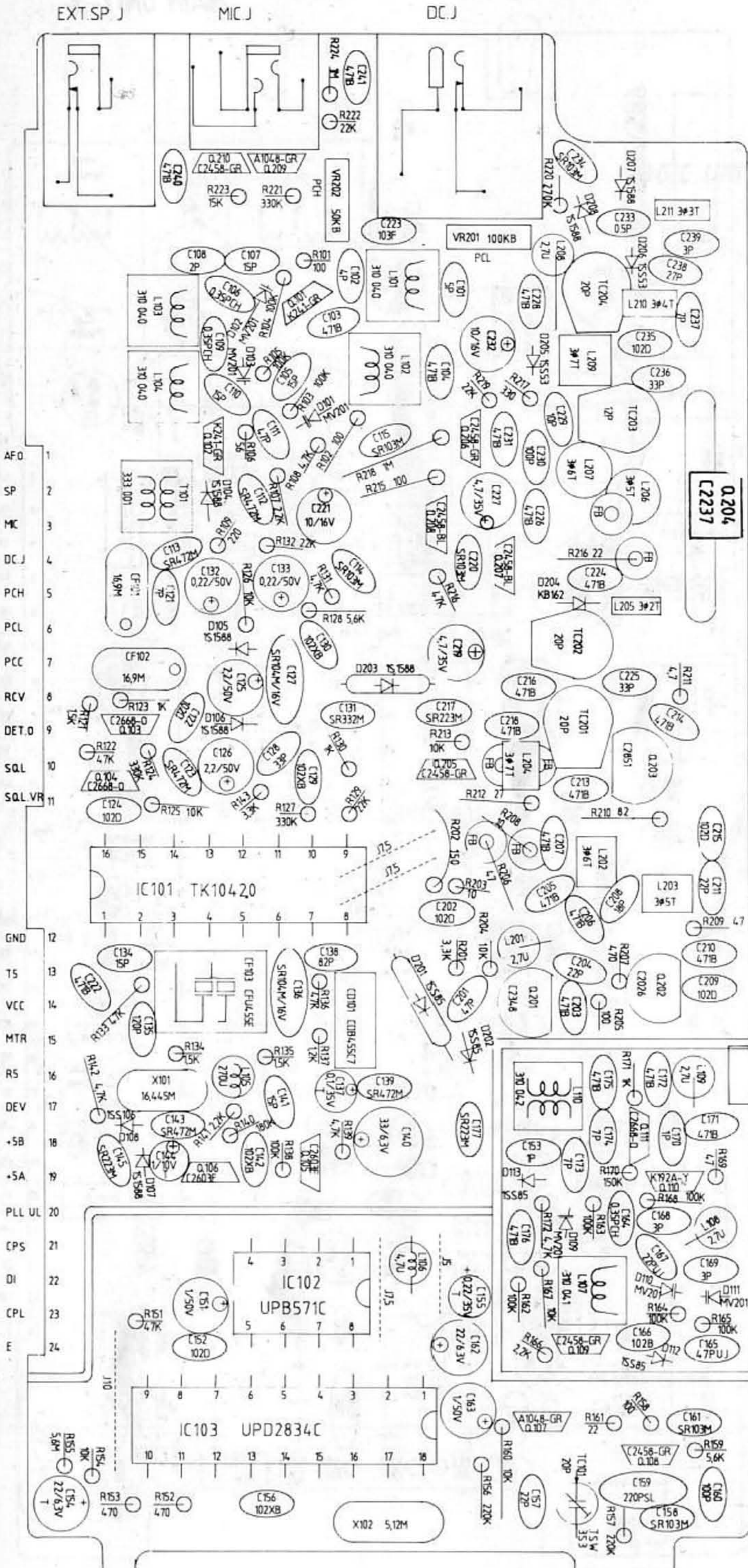

MAIN UNIT-2-

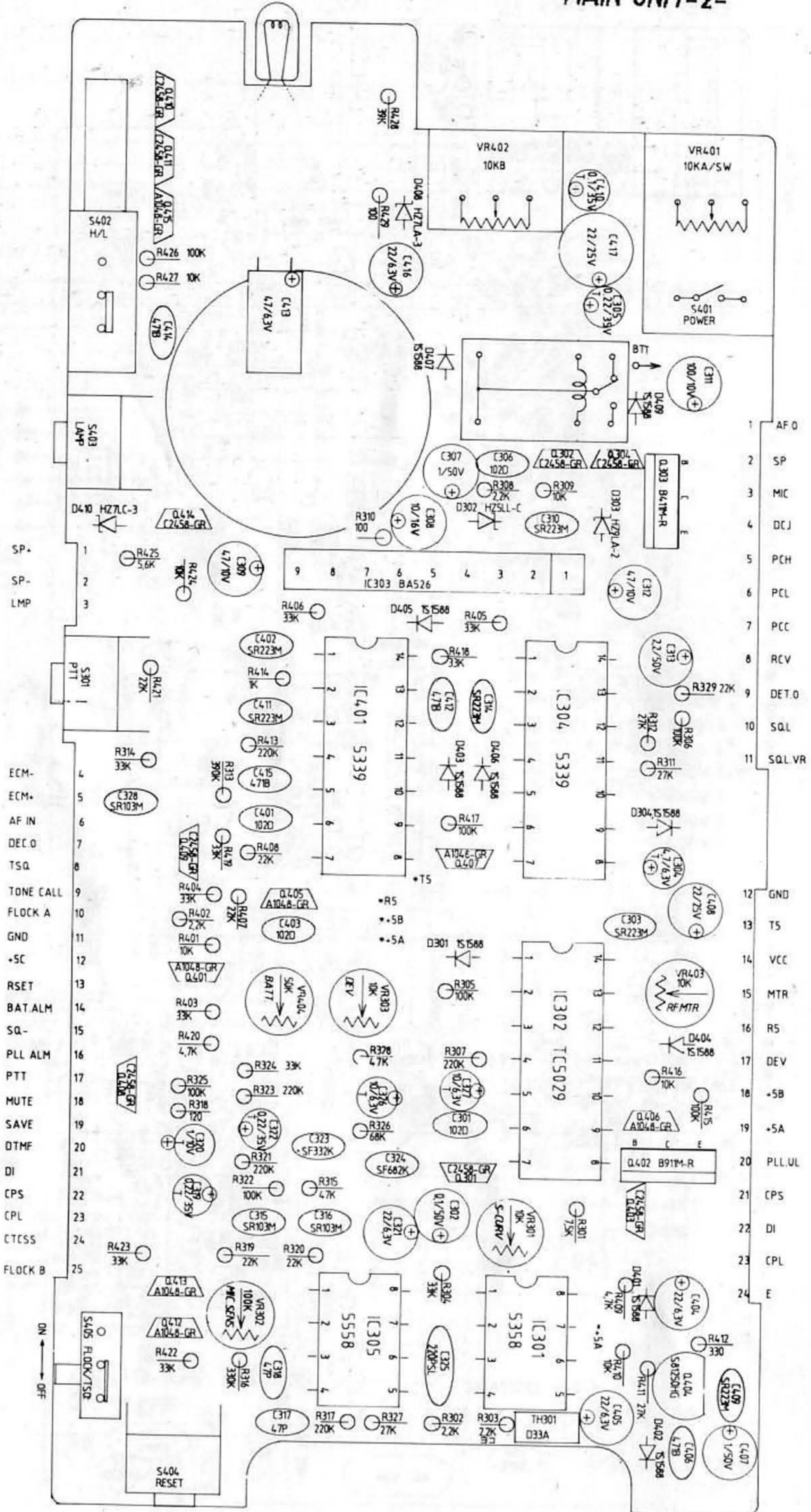

LOGIC UNIT-3-

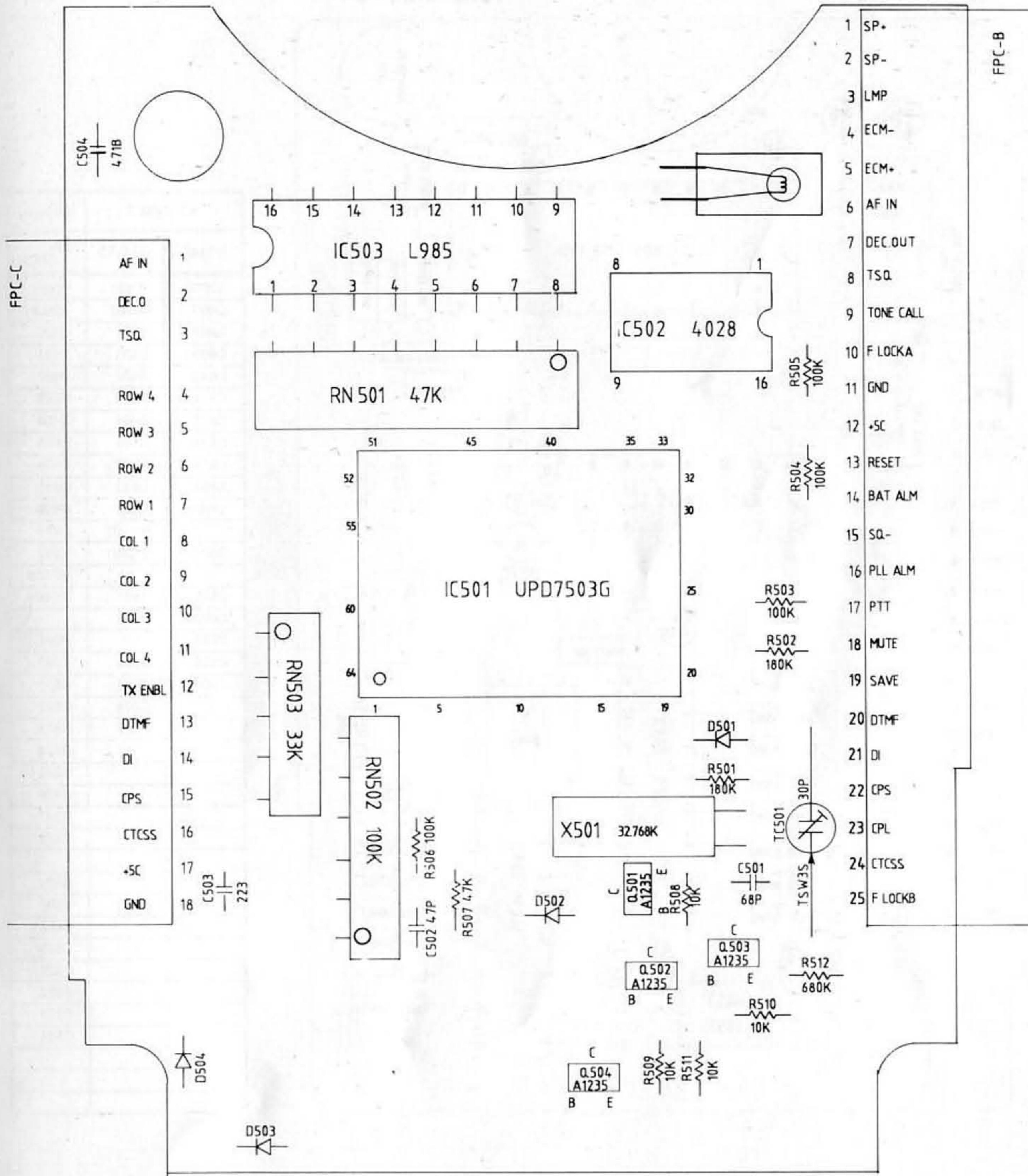

TONE UNIT-4-

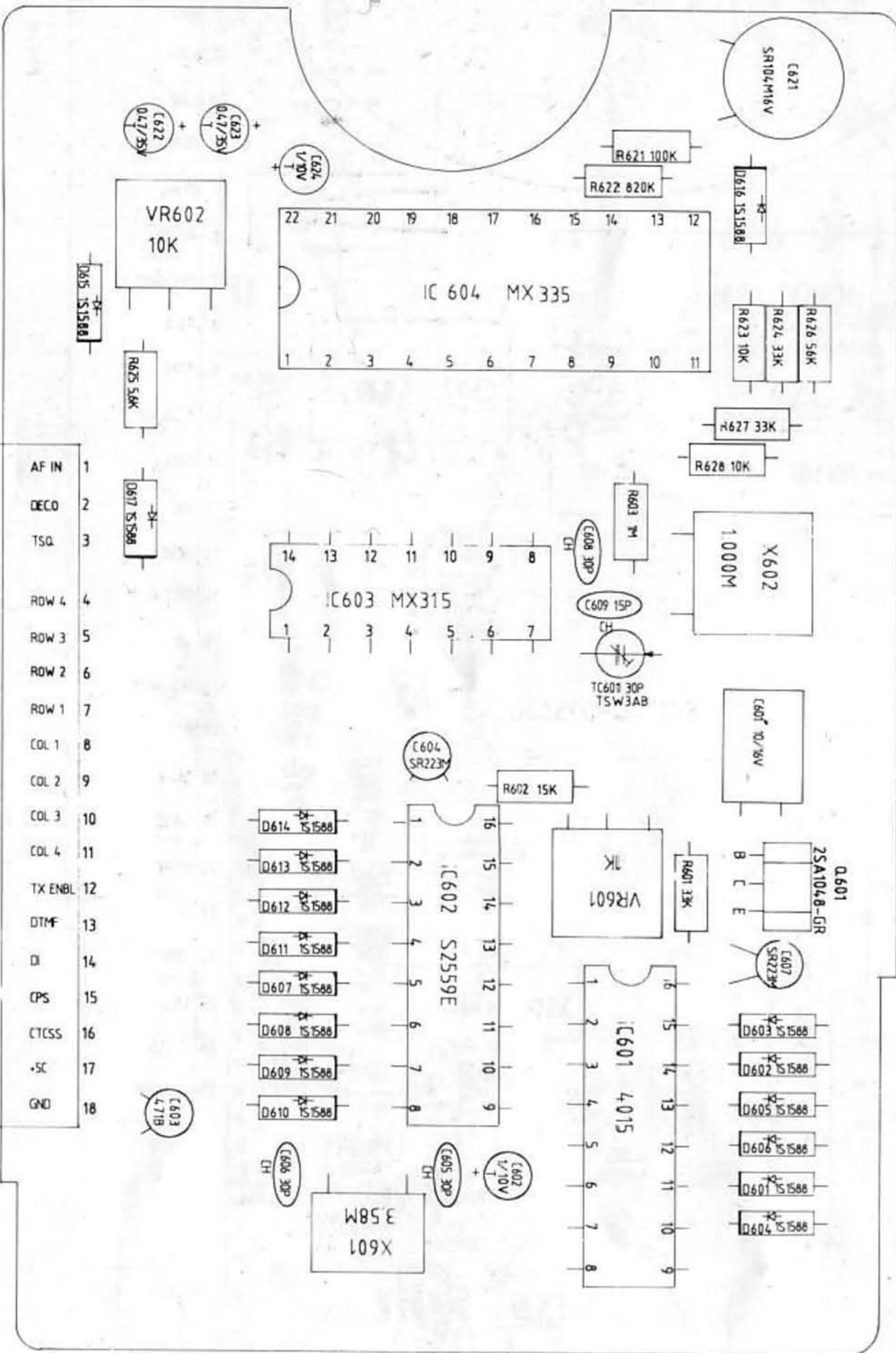

KT-220ET		OPTION
DTMF	CTCSS	TSA/ CTCSS
IC602	IC601	IC601
D607	IC603	IC604
D608	Q601	Q601
D609	D601	D601
D610	D602	D602
D611	D603	D603
D612	D604	D604
D613	D605	D605
D614	D606	D606
X601	D615	D615
VR601	X602	D616
	VR602	D617
R602	TC601	X602
		VR602
C602	R601	TC601
C603	R603	
C604		R601
C605	C601	R603
C606	C607	R621
	C608	R622
	C609	R623
		R624
		R625
		R626
		R627
		R628
		C601
		C607
		C608
		C609
		C621
		C622
		C623
		C624

TOYOMURA ELECTRONICS CO.,LTD.

2-7-9,SOTO-KANDA, CHIYODA-KU, TOKYO 101, JAPAN TEL.:03-251-7719

CABLE:CQ TOYOMURA TELX.:NO.02226408 CQ TEC J