

# “The MMR-40”

## CW - SSB QRP Rig

A KD1JV Design, kitted by qrpkits.com

Revised 3-13-07 (rev A)

Revised 7-11-07 (rev B)

The MMR-40 (Multi Mode Rig) features both CW and SSB operation, the first kit in this price class to do so. The reasonably small size, low power consumption and nearly full band coverage of 40 meters makes this rig ideal for portable, back up or emergency use.

### Specifications:

Receiver sensitivity:	0.2 uV MSD typical
Audio output:	500 mw
Receiver current:	30 ma, no signal
Transmitter power out:	6 watts CW/pep typical at 13.8V supply
Transmitter spurs:	-50 dBc or better
Transmitter current:	900 ma at 6 watts CW output
SSB frequency response:	400 Hz to 3000 Hz
PTO drift:	From cold start, 200 Hz or less during 10 minute warm up.
Tuning rate:	About 13 kHz per knob revolution
Typical tuning range:	SSB: 7.260 to 7.130 MHz CW: 7.130 to 7.000 MHz
Power supply:	11 to 14 volts, 12.5 to 13.8 recommended.

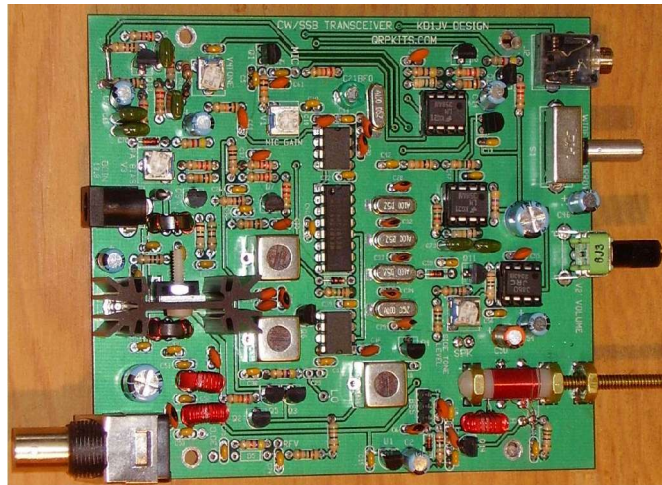

## Operation:

### Front panel controls and jack

#### Tuning:

This is a “backwards” tuning rig. Turning the tuning knob clockwise lowers the operating frequency. The only other thing to remember is that there is no stop when tuning counter-clockwise. Be careful not to turn so far as to remove the tuning screw from the coil nuts.

#### Band Segment Select:

The tuning range of the PTO (Permeability Tuned Oscillator) is about 130 kHz. A slide switch, accessed from the bottom of the rig, is used to switch a capacitor in and out to shift the PTO tuning range between the CW and voice segments of the band. When the switch actuator is towards the front of the case, the CW segment is selected and when switched towards the rear of the case, the voice segment is selected.

#### Volume:

Does this really need any explanation?

#### Wide/Narrow filter select:

This slide switch selects either the Wide (SSB mode) or Narrow CW audio filter. Using the CW filter significantly improves the selectivity of the receiver. Using the CW filter when in CW mode will help you match the other stations frequency, by making the tuning sharper. Ideally, the received CW note should match the rig's side tone frequency to exactly match the other stations frequency. Only people with perfect pitch can achieve this easily. The rest of us will have to rely on the CW filter to help us out.

#### MIC/KEY jack.

A single 3.5 mm stereo phone jack is used for both the microphone and PTT/CW key input. The MIC input is the RING of the plug and the PTT or CW key input is the TIP. When a CW key with a mono phone plug is inserted into the jack, the rig will automatically switch to CW mode by enabling the keying of the CW tone oscillator.

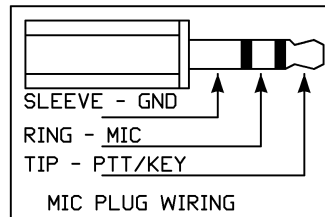

### Rear Panel jacks

#### Antenna:

A standard BNC connector is used here.

#### DC IN:

12 to 14 volts DC at 1 amp minimum is connected here. A 5.5 mm x 2.1 mm barrel power plug will match the jack. A 2 amp (fast blow, standard or mini size) fuse is recommended to be in line with the power supply.

#### Use of headphones:

Because there is no AGC or other audio level limiting in the rig, the use of headphones is not recommended. If you do wish to add a headphone jack, use one which will allow putting a 100 ohm or larger resistor in series with the headphones to help limit the maximum volume to a safe level.

## Adding accessories:

### Digital Dial:

There is a set of three pads located near T1. Two of these are labeled "LO" while the third is "G" or ground. A signal for a Digital Dial frequency counter can be connected to one of the pads labeled "LO" and the ground pad.

### External VFO:

If you would like to use an external VFO, such as a DDS, it can be connected to the "LO" pad just above the ground pad. The internal PTO is disconnected by cutting the track connecting the two LO pads together on the bottom of the board. If Header pins are used in the holes, the external VFO can be made to plug in and the use of the internal PTO re-enabled by using a shorting plug to reconnect the two LO pads. Note that this does not turn off the PTO, it simply disconnects it from the mixer. External VFO level should be about 1 volt peak to peak.

### Line out Audio.

There is a pad labeled "AUDIO LINE OUT" behind the filter select switch. This can be wired to a jack on the back of the rig so that the receiver audio can be connected to a PC sound card and not be affected by the volume control. Note that this output is not DC isolated, so adding a DC blocking cap (1 ufd, plus side to line out hole) at the jack is recommended.

### Digital modes:

While not specifically designed for use with digital modes, using them is possible. The only consideration is to keep transmissions fairly short. This will keep the PA cool and prevent drift in the PTO from getting out of hand. If the digital mode program you have supports AFC, this will help keep you on frequency by locking back onto the other stations frequency during receive portions of the QSO. Dilling a couple of vent holes in the top of the cabinet next to the heat sink might also be a good idea.

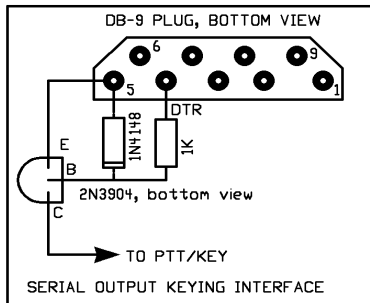

Most RTTY/PSK programs will key the rig using the DTR output on the RS-232 serial port connector. A simple level converter is shown in the diagram to the right. Ground return will be supplied by the audio ground connection.

If DC isolation is desired between the PC and rig, the transistor and diode can be replaced by an opto-isolator.

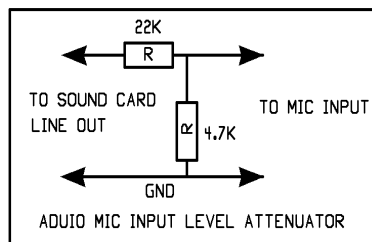

In addition, the audio output from the PC sound card should be attenuated before connecting to the mic input of the rig, as shown to the right. This will allow using an audio level from the PC which is in the low to mid range, rather than nearly completely off. DC blocking capacitors are not needed, so long as the resistor connected across the mic input and ground is greater than 4.7K. This will ensure the rig is not tricked into going into CW mode.

For DC isolation of the audio, put a 600:600 modem transformer on the PC side of the attenuator.

## Parts list 40M CW/SSB RIG parts check list

	<b>quantity</b>	<b>value</b>		<b>quantity</b>	<b>value</b>	
	3	10 OHMS	All resistors 1/4W, 5%	2	4.7 p	NPO disk
	3	51 OHMS		4	22 p	NPO disk
	4	100 OHMS		7	33 p	NPO disk
	2	470 ohms		2	47 p	NPO disk
	1	1.5 K				
	4	2.2 K		4	330 p	C0G multilayer
	4	4.7 K		1	680p	C0G multilayer
	7	10 K		9	1000p	disk
	8	22 K		27	.1 uF	X7R multilayer
	1	47 K		6	.022 uF	FILM
	1	100 K		5	1 uF/25V	Aluminum electrolytic
	6	1 MEG		2	10 uF/16v	Aluminum electrolytic
	4	10K trimmer		1	47uF/16	Aluminum electrolytic
	1	10K audio	PC mount, RA	2	330 uF/16	Aluminum electrolytic
				1	30 p trimmer	Green
	2	78L05	5V regulator			
	1	LM386	Audio amp	5	10.000 MHz	crystal
	2	LM358	Dual LP op amp	3	10.7 IF xformer	10 mm, brown slug
	1	74HC4053	Analog multiplexer	3	T37-2	Red
	2	SA602/612	Mixer/osc	2	FT37-43	black
	7	2N7000	TFET	1	SPST slide	switch
	4	2N4401	NPN, 500 ma	1	DPDT RA slide	switch
	1	2N4403	PNP, 600 ma	1	RT angle pc mount BNC	
	1	IRF510	Power MOSFET	1	3.5mm Stereo jack	
	1	J310	j-fet	1	nylon spacer	#6, 0.625" long Hex (L1 Coil form)
	5	1N4148	Small signal	1	#6-1/4	Nylon screw
	1	1N5231B	5.1V zener	1	#4-32 1/4	Nylon screw
	1	1N5817	Schottky	3	#6-32	Brass nuts
	3	8 pin dip		1	#6-32	2" brass screw
				1	Heat sink	
	1	Speaker	2" dia low profile	4 feet	#32 wire	
	1	cabinet	5 x 5 x 1.5"	5 feet	#30 wire	
	1	Knob	1/2"	1	#6-32.25	Brass 1/4" round Threaded spacer
				1	Pwr jack	5.5 mm x 2.1 mm pin
				4	#4-32 1/4"	screws
	1	Circuit board		1	#4-32	nut

### Assembly: Please read through all the assembly instructions before starting!

Before any parts are installed on the board, the nuts for the PTO coil are soldered in place. If this is not done now, it will be difficult to do later.

#### PTO nut installation:

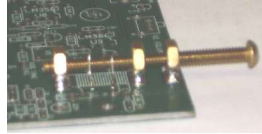

1. Clean any tarnish off edges of the nuts to make them easier to solder.
2. Thread the three brass nuts onto the brass screw.
3. Space the two nuts towards the end of the screw so that the nylon spacer fits snugly between them. Then back off one of the nuts a turn or two so there is a little "wiggle" room for the spacer to fit between. Do not put the spacer on the screw, as it will melt when the nuts are soldered in place.
4. Position the third nut so it sits on the solder pad at the front edge of the board when the rear nuts are placed over their respective solder pad/nut outlines.
5. Clip two 1" long leads from a resistor (leaving enough on the resistor so you can use it latter) and from them into a "U". Use these "U" shaped leads to hold the nut/screw assembly in place on the board, using the pair of holes on either side of the screw. You can just fold over the leads on the bottom of the board or solder them in place. Crimp the leads against the screw for a more secure fit.
6. Make sure the nuts are centered on the solder pads and the screw is as square to the front edge of the board as you can manage.
7. Solder one side of the nut at the front edge of the board to the large solder pad. Before you solder the other side, recheck the alignment of the screw to make sure its still square to the board. Solder the two remaining nuts in place.
8. Once the nuts cool down, remove the leads holding down the screw and remove the screw.

#### Winding L1, the PTO coil.

1. Thread the nylon spacer onto the brass screw and snug it up against the head of the screw. This will give you something to hold onto as you wind the coil.
2. The coil is wound with #32 wire. Be sure to identify this wire properly, as it just a little thinner than the #30 used for the other coils. If the #30 is used by mistake, you will not be able to fit nearly the required number of turns on the coil form.
3. There are two small holes drilled into the side of the spacer. Locate the hole near the head of the screw and thread the end of the #32 wire into and through this hole and pull out about 1 inch. Then loop it back through the hole. The diagram to the left has the loop exaggerated for clarity. Pull the wire snug to the hole, this will secure it in place.
4. The full length of the # 32 wire will be used to wind the spacer. Uncoil the wire and straighten it out before you start winding the spacer so it doesn't get kinked.
5. Spin the screw/spacer with one hand, while guiding the wire by using your thumb and forefinger of the other hand. Try not to overlap turns and occasionally use a finger nail to snug up the turns against each other. The thin #32 wire is easy to break. While you want the turns to be snug, don't use so much tension that you risk breaking the wire.
6. It is nearly impossible to keep track of the number of turns. Don't even try. Just fill up the space between the two holes. A few turns more or less won't matter, though it is better to have a few too many than too few. It's easier to remove turns than it is to add them! If you do count turns, you should end up with 39, +/- one or two.
7. When you get to the second hole, thread and loop the remaining wire through it.

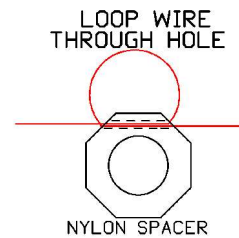

#### Mounting the coil:

1. Remove the screw from the spacer.
2. Slide the spacer/coil assembly between the 2<sup>nd</sup> and 3<sup>rd</sup> nut from the front of the board. Note that the holes in the spacer are not evenly spaced from each end of the spacer. Put the end with the hole closest to the end of the spacer towards the 3<sup>rd</sup> nut from the front of the board.
3. Thread the brass screw into the nuts from the front of the board and then into the spacer. If need be, rotate the spacer so the screw goes into it smoothly.

4. Insert the ¼" long # 6 nylon screw into the nut at the rear of the coil. Again, rotate the spacer if needed to allow the screw to thread into it smoothly. If there is any play in the spacer between the nuts, snug the spacer up against the rear nut. This will keep it from spinning with the tuning screw.
5. Trim and tin the coil wire ends and solder into the pads labeled "L1" on the parts placement drawing. There may be a little side to side play in the tuning screw. This can be improved by soldering a "U" shaped lead over the screw by the nut at the front of the board to put some downward pressure on the screw. You will have to scrape off some solder mask from the board to solder the wire loop to the board.

Now is a good time to solder the little slide switch used to select band tuning segments with to the board. This switch is mounted to the bottom of the board and soldered from the top side. You will have to remove the nylon screw holding the back end of the PTO coil to the nut to solder the switch pins closest to the nut. The switch can be installed later, but it will be harder to remove the nylon screw with the surrounding parts installed.

### **Board assembly:**

Print a copy of the board layout on the next page for easy reference. The part values are labeled in red. Experienced builders will need little more than this diagram to build the board. All parts, **with the exception of the PA (IRF510) and heat sink**, are installed before any testing is done. Since component designation numbers are somewhat randomly located around the board, the board is divided into four quadrants. This will make locating where the part goes on the board easier when using the part by part placement listings on the following pages. You may also want to presort the parts according to type and value and place them in small bowls to keep them from getting lost. Parts are installed in the order of their height. The lowest profile parts are installed first, then progressively taller ones. After putting a part on the board, bend the leads slightly to one side so the don't fall out when you flip the board over to solder. Several parts can be put on the board before you start soldering.

### **Diodes:**

There are 6 glass diodes. One of these is the 1N5231B zener diode. Identify this one first. Install the 1N5231B in location D4, in the lower left quadrant. (Note: zener supplied with kit likely to be marked 231B) Now install the remaining five 1N4148 diodes and D6, the 1N5817 which has the black plastic body.

### **Resistors:**

The resistor table is laid out in a four quadrant format. Locations in the quadrant are listed left to right, top to bottom. The color codes for several resistor values can be easily mistaken at a quick glance. In particular, be careful of 51 ohms (Green/Brown/Black) and 1 Meg ohms (Brown/Black/Green). These are VERY easy to mix up. Values which are in decade increments can also be confused, such as 470, 4.7K and 47K. So, take a good look at the colors before you solder the part in place! Leads are bent tight to the body of the resistor. Sometimes you have to help them a little with your needle nose pliers to make them sit flat on the board. Do not stand parts up off the board. There's no reason to do so and it looks bad.

### **Small capacitors:**

These are listed in the second table divided into quadrants. The .1 uF (104) caps and some of the small disk ceramics maybe supplied with lead spacing which do not fit the hole pattern of the board. For the .1 caps, you can use your needle nose pliers to reform the leads by kinking them in slightly and then flush with the bottom of the body of the cap. This will make them sit closer to the board. For the ceramics, use your pliers to crush the coating covering the leads near the body of the cap and straighten out the lead. This operation takes but a few seconds and results in a more ascetically pleasing looking finished product.

### **Remaining parts:**

These parts are listed in the third table, in a linear format. The part location quadrant is noted, along with any special notes.

Once the parts listed in the third table are installed, the toroid coils are wound and mounted, followed by the jacks, switch, and volume control.

Parts placement guide. Print out this and the following three pages for easy reference while building the board.

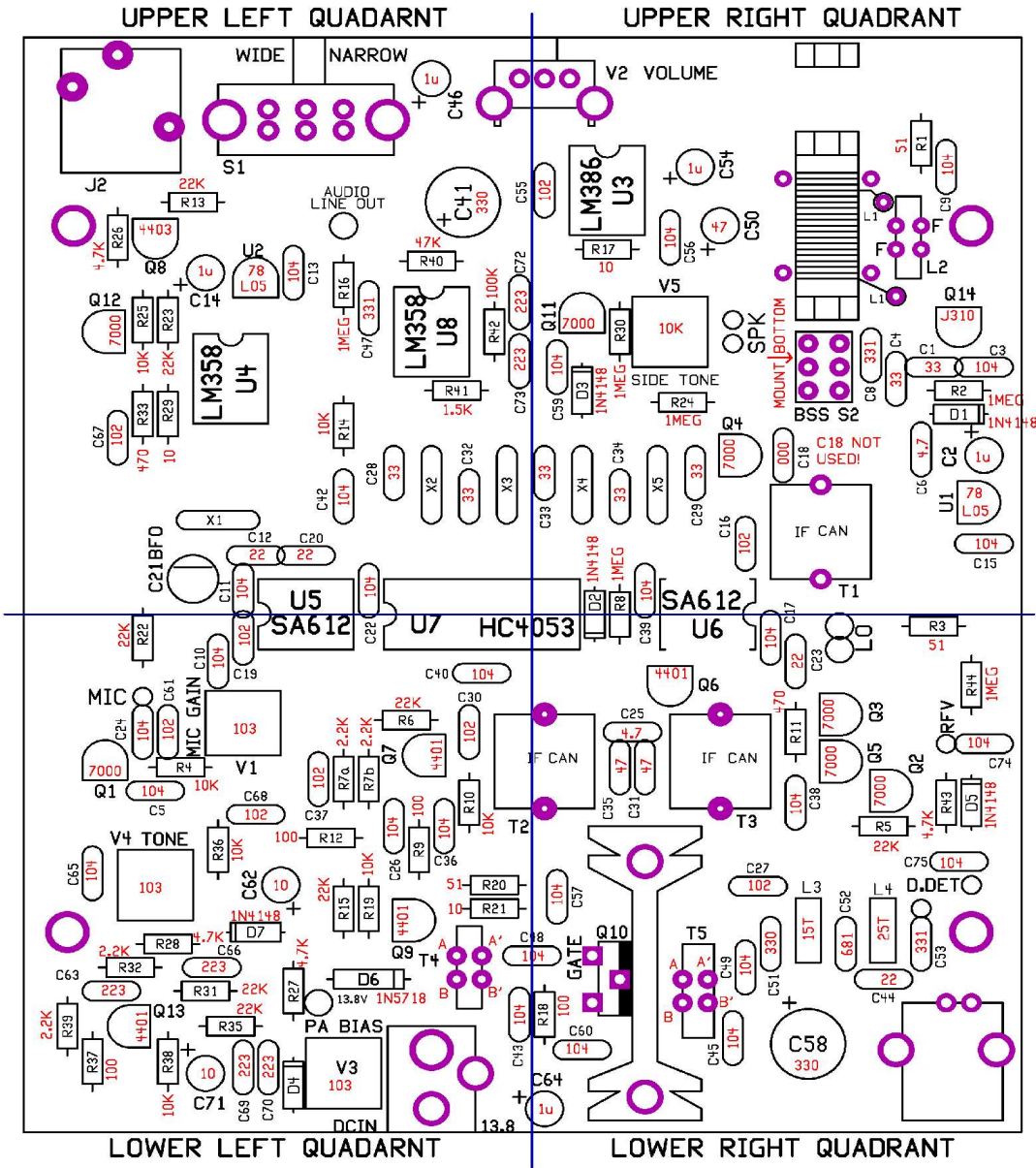

**Q10 and heat sink are installed after initial board tests.**

## Resistors

Quad(rant): U.L. -Upper Left, U.R. - Upper Right, L.L. -Lower Left, L.R.- Lower Right  
 All resistors ¼ watt carbon film, 5 % - last band gold.

<i>quad</i>	<i>loc</i>	<i>value</i>	<i>Color code</i>		<i>qud</i>	<i>loc</i>	<i>value</i>	<i>Color code</i>
U.L.	R13	22 K	RED/RED/ORG		U.R.	R1	51	GRN/BRN/BLK
U.L.	R26	4.7 K	YEL/VOL/RED		U.R.	R17	10	BRN/BLK/BLK
U.L.	R40	47 K	YEL/VOL/ORG		U.R.	R30	1 MEG	BRN/BLK/GRN
U.L.	R25	10 K	BRN/BLK/ORG		U.R.	R24	1 MEG	BRN/BLK/GRN
U.L.	R23	22 K	RED/RED/ORG		U.R.	R2	1 MEG	BRN/BLK/GRN
U.L.	R16	1 MEG	BRN/BLK/GRN					
U.L.	R42	100 K	BRN/BLK/YEL					
U.L.	R33	470	YEL/VOL/BRN					
U.L.	R29	10	BRN/BLK/BLK					
U.L.	R41	1.5 K	BRN/GRN/RED					
U.L.	R14	10 K	BRN/BLK/ORG					
L.L.	R22	22 K	RED/RED/ORG		L.R.	R8	1 Meg	BRN/BLK/GRN
L.L.	R6	22 K	RED/RED/ORG		L.R.	R3	51	GRN/BRN/BLK
L.L.	R4	10 K	BRN/BLK/ORG		L.R.	R44	1 Meg	BRN/BLK/GRN
L.L.	R7a	2.2 K	RED/RED/RED		L.R.	R11	470	YEL/VOL/BRN
L.L.	R7b	2.2 K	RED/RED/RED		L.R.	R43	4.7 K	YEL/VOL/RED
L.L.	R10	10 K	BRN/BLK/ORG		L.R.	R5	22 K	RED/RED/ORG
L.L.	R9	100	BRN/BLK/BRN		L.R.	R18	100	BRN/BLK/BRN
L.L.	R12	100	BRN/BLK/BRN					
L.L.	R36	10 K	BRN/BLK/ORG					
L.L.	R20	51	GRN/BRN/BLK					
L.L.	R21	10	BRN/BLK/BLK					
L.L.	R27	4.7 K	YEL/VOL/RED					
L.L.	R15	22 K	RED/RED/ORG					
L.L.	R19	10K	BRN/BLK/ORG					
L.L.	R28	4.7 K	YEL/VOL/RED					
L.L.	R32	2.2 K	RED/RED/RED					
L.L.	R31	22 K	RED/RED/ORG					
L.L.	R39	2.2 K	RED/RED/RED					
L.L.	R35	22 K	RED/RED/ORG					
L.L.	R37	100	BRN/BLK/BRN					
L.L.	R38	10 K	BRN/BLK/ORG					



## Small capacitors

Capacitor type: (M) multilayer, (F) film, (D) ceramic disk

NOTE: the lead spacing on the 0.1 (104) caps and some of the ceramic disk caps are too wide for the mounting holes. These can be made to sit closer to the board by reforming the leads a little with your needle nose pliers. For the 0.1 caps, grab the lead near the body and "kink" the lead up and flush to the body of the cap, forming a small upside down "L" on both leads. For the ceramic caps, simply crush the coating over the lead near the body of the cap and straighten out the lead.

	<i>quad</i>	<i>LOC</i>	<i>Type/value</i>	<i>code</i>		<i>quad</i>	<i>LOC</i>	<i>Type/value</i>	<i>code</i>
	U.L.	C13	(M) 0.1	104		U.R.	C9	(M) 0.1	104
	U.L.	C47	(M) 330 p	331		U.R.	C55	(D) 0.001	102
*	U.L.	C72	(F) 0.022	223		U.R.	C56	(M) 0.1	104
*	U.L.	C73	(F) 0.022	223		U.R.	C8	(M) 330 p	331
	U.L.	C67	(D) 0.001	102		U.R.	C1	(D) 33 p	33
	U.L.	C42	(M) 0.1	104		U.R.	C3	(M) 0.1	104
	U.L.	C28	(D) 33 p	33		U.R.	C59	(M) 0.1	104
	U.L.	C32	(D) 33 p	33		U.R.	C4	(D) 33 p	33
	U.L.	C12	(D) 22 p	22		U.R.	C33	(D) 33 p	33
	U.L.	C20	(D) 22 p	22		U.R.	C34	(D) 33 p	33
	U.L.	C11	(M) 0.1	104		U.R.	C29	(D) 33 p	33
	U.L.	C22	(M) 0.1	104		U.R.	C18	00 p	NOT USED
						U.R.	C6	(D) 4.7 p	4.7
						U.R.	C16	(D) 0.001	102
						U.R.	C15	(M) 0.1	104
						U.R.	C39	(M) 0.1	104
						L.R.	C17	(M) 0.1	104
	L.L.	C19	(D) 0.001	102		L.R.	C23	(D) 22 p	22
	L.L.	C10	(M) 0.1	104		L.R.	C25	(D) 4.7 p	4.7
	L.L.	C40	(M) 0.1	104		L.R.	C35	(D) 47 p	47
	L.L.	C24	(M) 0.1	104		L.R.	C31	(D) 47 p	47
	L.L.	C61	(D) 0.001	102		L.R.	C74	(M) 0.1	104
	L.L.	C30	(D) 0.001	102		L.R.	C38	(M) 0.1	104
	L.L.	C5	(M) 0.1	104		L.R.	C75	(M) 0.1	104
	L.L.	C37	(D) 0.001	102		L.R.	C57	(M) 0.1	104
	L.L.	C68	(D) 0.001	102		L.R.	C27	(D) 0.001	102
	L.L.	C26	(M) 0.1	104		L.R.	C51	(M) 330 p	331
	L.L.	C36	(M) 0.1	104		L.R.	C52	(M) 680 p	681
	L.L.	C65	(M) 0.1	104		L.R.	C53	(M) 330 p	331
	L.L.	C48	(M) 0.1	104		L.R.	C49	(D) 0.1	104
*	L.L.	C66	(F) 0.022	223		L.R.	C44	(D) 22 p	22
*	L.L.	C63	(F) 0.022	223		L.R.	C60	(M) 0.1	104
	L.L.	C43	(M) 0.1	104		L.R.	C45	(M) 0.1	104
*	L.L.	C69	(F) 0.022	223					
*	L.L.	C70	(F) 0.022	223					

\* you might want to put these caps on last, as their much taller than the other caps.

	<b>location</b>	<b>VALUE</b>	<b>QUADRANT</b>	<b>NOTES</b>
	X1-2-3	10.000 MHz	U.L.	DO NOT STAND OFF BOARD, case will not short to pads.
	X4-5	10.000 MHz	U.R.	The cases X1 to X4 are soldered to the solder pads at the edge of the can. Solder will stick to the can easier if you run a file along the side of the can first.
	U4-8-3	SOCKET	U.L. U.R.	ONLY THESE 3 IC's USE SOCKETS
	Q8	2N4403	U.L.	THERE IS ONLY ONE OF THESE, DON'T MISTAKE IT FOR A 2N4401
	U2	78L05	U.L.	CENTER LEAD BENDS TOWARDS ROUND SIDE OF PACKAGE.
	Q12	2N7000	U.L.	These can be static sensitive.
	Q11	2N7000	U.R.	Use precautions if its cold and dry outside.
	Q14	J310	U.R.	
	Q4	2N7000	U.R.	
	U1	78L05	U.R.	SEE U2 NOTE
	Q1	2N7000	L.L.	
	Q7	2N4401	L.L.	
	Q9	2N4401	L.L.	
	Q13	2N4401	L.L.	
	Q6	2N4401	L.R.	
	Q3	2N7000	L.R.	
	Q5	2N7000	L.R.	
	Q2	2N7000	L.R.	
	U5	SA602	CENTER	SOLDER DIRECT TO BOARD
	U7	74HC4053	CENTER	SAME AS ABOVE
	U6	SA602	CENTER	PIN 1 FACES OPPOSITE DIRECTION THAT OF U5 AND U7.
	V5	10K Trimmer	U.R.	
	V1/4/3	10K Trimmer	L.L.	
	C21	30 p trimmer	U.L.	Green, flat side towards line on outline
	C46/C14	1 uF / 25V	U.L.	LONG LEAD IS PLUS FOR ALL ELECTROLYTICS
	C41	330 uF / 16V	U.L.	THIS CAP CAN EXPLODE IF INSTALLED BACKWARDS!
	C54/C2	1 uF / 25V	U.R.	
	C50	47 uF / 16V	U.R.	
	C62/C71	10 uF / 16V	L.L.	
	C64	1 uF / 25V	L.R.	
	C58	330 uF / 16V	L.R.	SEE C41 NOTE
	T1/2/3	IF CANS	U.R. / L.R.	SOLDER THE MOUNTING TABS TOO.
	Q10	IRF510A	LR	DO NOT install Q10 or heat sink until after initial tests are done

## Assembly is now almost complete. Time to wind the coils, L2,3 and 4.

### Toroid winding:

**Note: wind the wire on L2, L3 and L4 snug to the core, but not so tight the wire can't be moved, as you will need to fine tune the spacing of the turns later for best performance.**

L2:

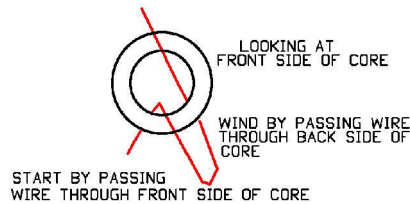

Note: The way in which the turns are wound on the core for L2 is important. If wound the “wrong” way, the windings will not match the connections on the board in the proper sequence and the oscillator will either be too high in frequency or will not start.

Begin the first turn by passing one end of the wire into the hole in the core from the FRONT SIDE. (front being the side of the core your looking at) Now continue winding by passing the long end of the wire through the hole from the BACK SIDE. You will be winding the wire in a counter clockwise direction.

- Wind 28 turns (17” of the #30 wire) onto one of the red T37-2 toroid cores. Remember, a turn is each time the wire passes through the center of the core.
- After putting on turn number 28, make about a 1” loop of wire and continue winding 5 more turns. This will be the feedback winding.
- When finished winding, snip the loop to separate the main winding from the feedback winding. When mounting the coil to the board, make sure the feedback winding wires go into the holes labeled “F”.
- To help keep track of which winding is which, make one set of leads longer than the other set. If wound properly, the ends of the wires should have this pattern while looking at the core from the bottom:

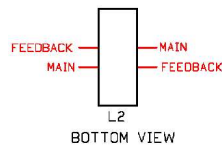

L3 and L4:

- Wind 15 turns (9” of # 30) on another red T37-2 core and mount in the L3 location.
- Wind 25 turns (14” of # 30) on the remaining red core and mount in the L4 location.

### T4 and T5 winding:

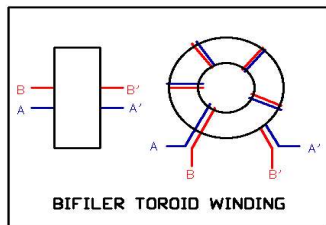

T4 and T5 are bifiler wound transformers. This simply means they use two wires of equal turns. Loop 8” of #30 wire and lightly twist it together. Wind the black FT37-43 core with five (5) turns. Snip off the end of the loop and tin all four wire ends. To work properly, the two ends of each wire has to be adjacent to each other on either side of the core. Use your ohmmeter once again to identify the two ends of one of the wires. If need be, move one of the ends so it is opposite the other when looking at the bottom of the core. See diagram. Now when the core is mounted on the board, the tracks will connect to the proper ends of the windings.

### Final parts:

Finish board assembly by installing the following parts:

- Stereo 3.5 mm jack
- Filter select Slide switch
- Volume control
- DC power jack
- BNC jack
- Band Segment Selector switch. (if not already installed) This is mounted onto the bottom side of the board. You will have to remove the nylon screw at the back end of the PTO coil to solder the pins of the switch closest to the nut, although these pins really don't need to be soldered if removing the screw it too much trouble.

## Testing and tune up:

At a minimum, you will need a DVM or multimeter, a shortwave radio capable of tuning down to 2 MHz, a QRP RF power meter and 50 ohm dummy load, good for up to 10 watts. A frequency counter and Oscilloscope would help immensely, should they be available to you. If you don't have a RF power meter which is reasonably accurate at 3-5 watt range, you can use the diode detector built onto the board instead. You will still need a 50 ohm dummy load.

### Initial tests:

Before you apply power to the circuits, do a quick ohm meter check from the DC IN to ground and make sure there are no shorts there. You might see a momentary low resistance reading as the input filter caps charge up, but the resistance reading should quickly rise to infinite. If there is a short, find and remove it.

- Apply power to the board, 12 to 13.8 volts.
- Check to make sure there is 5 V, +/- 0.25 V, coming out of the two regulators, U1 and U2.
- Insert the tuning screw fully into the PTO coil.
- Select the CW band segment tuning range with the Band Segment Selector switch. (slide towards front of board)
- Bring over the short wave radio, ideally one with a digital dial and if it has a BFO, thats even better. If you have a HF rig with general coverage, use that. Place the antenna near the PTO. If you have a frequency counter it can be connected to the pad labeled "LO", though this will shift the frequency slightly lower.
- You should find the oscillator signal at about 3 MHz. If the frequency is much higher than 3 MHz, you likely have the feedback and main winding reversed on the board. The frequency can be fine tuned by changing the spacing of the wire on the L2 toroid. Moving the turns closer together will decrease the frequency, while spreading them apart will increase the frequency. Adjust the turns spacing on L2 so that the oscillator frequency is slightly below 3 MHz. This will ensure you can not tune below the 40 M band allocation. If you can't get up to 3 MHz by changing the spacing of the turns on L2, you likely have a few too many turns on the PTO coil and have to remove a few. Do this one turn at a time.
- Now remove the tuning screw from the PTO coil.
- The frequency should shift down to about 2.87 MHz.
- Switch the band segment selector switch to move the oscillator frequency to the voice portion of the band. (Slide towards rear of board)
- The oscillator frequency should now be about 2.75 MHz. This will translate to an operating frequency of 7.25 MHz and the upper tuning limit. If you want to tune more of the upper end of the phone segment, readjust the spacing of the turns on L2 to lower the frequency down towards 2.70 MHz, which translates to an operating frequency of 7.30 MHz. Doing this prevents tuning the lower part of the CW band, so you will have to decide which end of the tuning range is more important to you.

It will be difficult to find the exact frequency using a typical AM only SW portable radio, due to its wide bandwidth. If a AM only SW receiver is all you have to use, it will be good enough for now to ensure you are tuning in the 40 M ham band. Greater accuracy would be archived with a HF rig with general coverage ability and used in the CW mode. Once the PTO frequency has been set, secure the L2 toroid to the board with a dab of hot glue. This will reduce micro phonic effects. You could also melt some wax over the coils and VFO parts. This will help with stability, but is a little messy and difficult to remove should you ever want to make changes. Coating L2 and L1 with some nail polish can also help.

- Remove power from board
- Connect a speaker to the SPK holes on the board. You can use the supplied speaker, but until its mounted in the case, it won't sound very good. If you have a speaker in a speaker cabinet, this would be better to use.
- Reapply power.
- Turn the volume control up and you should hear some audio hiss.
- Give the BFO trimmer, C21, about a ¼ turn from its factory setting. The capacitance of the trimmer goes from maximum to minimum in ½ turn (180 degrees) It is set to maximum as it comes from the factory, so turning it ¼ turn sets it to mid range. If you look inside the adjustment hole, you will see what looks like an arrow point on one end of the screw slot. When this points to the flat edge of the trimmer, the capacitance is at minimum.
- Connect an antenna to the antenna jack, then tune around for an on air signal.
- Once you find a signal, adjust the slug in the top of T1 for best signal strength.
- If the signal your tuned to is not a SSB station, try tuning around until you find one.
- If the voice sounds a little too much like Donald Duck, reduce the BFO frequency slightly (turn arrow

towards round end of cap) and re-tune the receiver. Main tuning and BFO are interactive. Finding the best setting for natural sounding voice is best done with a fairly strong signal which isn't using speech processing.

- The BFO can also be set with the aid of an audio spectrogram program running on your PC. This will require a wide band RF noise generator for best results, though if the band is very noisy, this noise will work. The spectrogram should be set to show the average of the signal, so you can see a fairly smooth response. The audio from the rig can be connected to the PC sound card line input with from the "LINE OUTPUT" terminal on the pc board.
- Set the BFO trimmer so the audio response falls off sharply around 300 to 400 Hz. Because of the slow response due to signal averaging of the noise, this adjustment needs to be done slowly. Viewing the audio response of the filter in this way, you will no doubt notice the response of the filter isn't very flat, with a bit of a dip in the upper 2000 Hz region.

If all went well, you now have a functional receiver. If not, you have some trouble shooting ahead of you. Refer to the trouble shooting section near the end of the manual.

### Now for the transmitter sections.

An RF voltage detector is built into the board, located just above the RF output jack. This will be used to peak up the transmitter stages.

- If you have changed it, reset Band Selector Switch to voice segment of the band and insert the tuning screw fully into the PTO coil. This will set the operating frequency to about mid band.
- The CW tone oscillator trimmer resistor, V4, should be at its factory setting of mid range.
- Solder a resistor lead clipping into the hole labeled RFV. You can use a clip lead to connect this to your DVM or make a loop in the end of the lead to slide the probe into.
- Clip the negative probe of the DVM to board ground. There is a tinned area on the corner of the board near the PTO oscillator for this.
- Solder a 3" length of hook up wire to the input of the diode detector (D.DET) to use as an input probe.
- Connect the RF voltage probe to where the pad labeled "GATE" of Q10. This end doesn't need to be soldered, just make sure you have a snug connection.
- Plug a straight key which uses a mono plug into the MIC/KEY (J2) jack. This enables the CW tone generator. You can also use a paddle. Closing the Dash paddle will enable the CW tone oscillator and the rig can be keyed into transmit with the Dot paddle.
- Apply power to the board.
- Key the transmitter and you should see some voltage from the RF probe. You should also hear the CW side tone from the speaker. This might be annoying after awhile, so you can disconnect the speaker for now or turn the level down with the side tone level trimmer.
- Now adjust the transmit band pass filter, T2 and T3 for the maximum voltage from the probe. Tuning is somewhat interactive, so work back and forth a few times between the two transformers until you get the best results. You shouldn't have to turn the slugs much, adjust them slowly and a little at a time. Assuming a 13.8 volt supply, you should be able to peak the voltage to 7 or 8 volts. The voltage will be lower if your using a lower voltage supply such as a gel cel.
- Un-key the rig and turn the CW tone oscillator level trimmer to full counter-clockwise.
- Key the rig again and the voltage from the RF probe should be at or near zero.
- If the voltage does not go to zero, the BFO isn't quite set right and there is carrier leaking through the crystal filter. Slightly re-adjust the BFO trimmer so the voltage drops to or near zero volts. The exact setting of the BFO trimmer is something of a compromise between having a minimal amount of carrier transmitted and having good low frequency response of the received and transmitted audio.
- Remove power to the board, disconnect the RF probe.
  
- Install the heat sink. Solder the tabs to the board. This will require some heat!
- Install the IRF-510. Make sure the mounting hole lines up with the hole in the heat sink and secure the tab of the '510 to the heat sink with the 1/4" 4-40 nylon screw and metal nut. An insulator is not required between the tab of the '510 and the heat sink, as the anodizing is non conductive. However, a nylon screw is used for securing the '510 to the heat sink, so that if the nut should cut through the finish on the heat sink, no shorts to ground will occur.
  
- Connect an amp meter in series with the power supply. Most DVMs have a 200 ma and 20 amp scale. Use the 20 amp scale, as the lower current scales are fuse protected and we can easily exceed 200 ma if not careful.
- Further, it is highly recommended to have a 2 amp fuse in series with the power supply to the board.
- **Connect a RF power meter and 50 ohm dummy load to the antenna jack.** If you don't have a QRP RF power meter, the diode detector can be used instead. There is a hole just below the D.DET input

which connects to the antenna jack. Put a short jumper between these holes to measure RF output voltage. Power output is approximately  $V^2 / 100$ , assuming a dummy load very close to 50 ohms.

1. Re-apply power to the board.
  2. Turn the CW tone oscillator off by adjusting the V4 level trimmer fully counter clockwise. If your using a paddle, you can use the dot paddle to key the transmitter, but don't enable the tone oscillator by keeping the Dash paddle open.
  3. Key the transmitter. Note the current being drawn by the board, which should be 90 to 100 ma.
  4. Slowly turn up the PA bias voltage with V3, until the current increases by 10 to 20 ma. Be careful not to go much past this, as the bias voltage can quickly get to the point where the IRF-510 is fully turned on. At this point, it will draw as much current as the supply will deliver – that is until something fries! Thats why its important to have that 2 amp fuse in line and a box of spares handy!
- Once the PA idle current is set, un-key the transmitter.
  - Key the transmitter again and increase the CW tone level until the RF power output stops increasing. This should occur at between  $\frac{1}{2}$  and  $\frac{3}{4}$  of a turn from full counter clockwise. Full power output with a 13.8V supply should be about 5 watts or greater.
  - Exact power output can be affected by the way the turns on the L3 and L4 coils are spaced around the core. L3 in particular has the most effect, as it affects matching between the PA and load. Start with the turns evenly spaced around the core, then move a few turns at a time closer together until you get the best power output. A little tweaking of the turns spacing can result in power outputs of up to 7 watts.

Power output will not be constant across the tuning range of the PTO and between the SSB and CW band segments. Some of this is due to a change in PTO signal amplitude due to the brass screw. The band width of the transmitter band pass filter also reduces power output as the frequency moves from the center frequency it was peaked at. This effect will be more pronounced below the center frequency of the filter. Therefore, power output will be fairly constant over the voice segment of the band and fall off as much as a few watts at the low end of the CW segment. That is why power output should be peaked near the center of the band. The low pass filter also affects power output because the optimum point of matching between the PA and load changes with frequency.

#### **Microphone gain:**

Setting the mike gain control is a little trickier. Too much gain and the signal will clip and distort. Too little gain and you will not have full modulation along with low power output. Start with the V1 trimmer set about 1/3d up from full counterclockwise. The best way to set the gain is to look at the transmitted signal with a 'Scope. Pictures of what a properly modulated signal should look like can be found in the ARRL handbooks. The next best option is to use a SSB receiver to listen to the signal and hear how it sounds. Be sure to use headphones with the monitor receiver and transmit into a dummy load. The exact setting depends on the sensitivity of the microphone and how loud you talk. If you're like me, you probably talk louder into a mike than face to face to another person. Just one of those things. If you have no way to look or listen to the signal, leave the setting at mid scale and try to get on air reports for fine adjustment. (Maybe with a local ham you can coordinate with over a 2 meter repeater)

#### **Mounting the board into the cabinet:**

Before mounting the board into the case, holes will need to be drilled into the panels and the top/bottom sections of the case.

#### **Front and rear panels:**

A 100% scale drill template (PANEL.BMP) is included in this instruction manual's software folder for drilling the front and rear panels. Open this file with "Paint" and print. The Paint program is supplied with Windows, going back to Win 3.1. It is found in the "accessories" directory. NOTE: Using Paint in Windows versions earlier than XP will likely scale the drawing to fit the page. When using XP, go to "print setup" first and make sure the "print 100%" box is checked. You can also use print preview to check to see if the scale looks right.

The front panel template can also be used to label the controls. If you wish, you can add color or other graphics to the image before printing. Light blue looks nice as a background. The templates are laid out so you can print them on a piece of 4 x 6 ink jet photo finish paper. Use the print setup menu to select "portrait" and set the top and left margins in the "print setup" menu to 0.0" so the image will be centered correctly. Check the print preview to make sure it fits. A coating of clear acrylic will protect the printing.

The template can be attached to the panel using double sided tape or spray on adhesive. However, before doing this, trim the template down to inner set of outlines. This allows for the top and bottom cover overlap of the panel. On the rear panel, the power connector has to stick through the panel a little, so you will have to trim the hole a little bigger than the outside edges of the connector.

#### **Bottom section of case:**

First, you will need to make a hole in the bottom cover section to access the band select switch. The bottom cover is the one with the screw holes for securing the two case pieces together. Make sure this is the piece you are going to drill into before doing so! Drill a hole 1.75" from the front edge of the cover and 1.375" from the right hand side. (looking at the outside, bottom, front up). Elongate the hole with a hobby knife or file so you can easily access the switch actuator.

#### **Speaker:**

The speaker is mounted to the top section of the case. Open and print the "SPEAKERDRILL.BMP" file with "MS Paint". This will provide you with a nice hole pattern for the speaker and will look better than some randomly drilled holes.

- The two cabinet pieces are keyed so they will go together only one way. Be sure to find the proper orientation to determine which end of the top piece will be towards the front.
- The center hole for the speaker should be located 2.5" from the front end of the cabinet top and 2.00" from the right side.
- Tape the drill diagram to the top of the lid and drill 1/16" guide holes through the paper at each hole center.
- Remove the guide and drill the full sized holes.
- Center the speaker over the hole pattern and tack the speaker in place in a couple of spots.
- Make sure the cover fits without the speaker hitting anything. If this is alright, run a bead of hot glue all along the lip of the speaker.

Although having an built in speaker is handy, you might want to add a jack to the rear of the case for an external speaker. For in shack use, this will give you better sound.

#### **Mounting the board:**

- Slide the back panel into the slots at the rear of the bottom section of the case.
- Place the front panel on the front to the board.
- Slide the RF connector and power connector into the holes in the rear panel and slide the front panel into the slots in the front of the case.
- Secure the board into the bottom of the case with the four 1/4" 4-40 machine screws. The threads on these screws are not ideal for screwing into the plastic holes of the case. Some force will be needed to get them started. Once the plastic has been threaded by the screws, they will go in and out a lot easier if you need to remove the board later.

#### **Putting the knob on the tuning screw:**

A round, 1/4" diameter plated brass spacer is supplied to put on the tuning screw so the knob will fit without wobbling. First, you will have to cut down the length of the screw so it doesn't stick out too far from the front panel when fully inserted into the coil. The quickest and easiest way of cutting the screw is with a Dremal cut off wheel. It is advised to use eye protection when doing this, as the wheel can shatter easily. A dust mask is also a good idea. Cut the screw about 1/2" from the head of the screw, producing a threaded rod 1.5" long. The spacer can be soldered to the end of the what is now a threaded rod, but remove some of the nickel plating off the end first, or you'll have a hard time getting the solder to stick to the spacer.

#### **Microphone:**

You will have to make or adapt a microphone to use with this rig. A common, inexpensive Electret mike cartridge is used. The simplest solution is to adapt an old CB mike. These come in two flavors, the dynamic and electret. The dynamics are often bad, as the cartridge can be damaged by abuse. These mikes often have a spot for an electret cartridge molded into the housing.

The mike for this rig has to be wired so its always under power. CB mikes wire the cartridge through the PTT switch, so this will have to be rewired. Remove the DIN plug on the end of the cord and wire up a 3.5 mm stereo plug, so that the mike connects to the ring (this is generally the yellow wire) and the PTT is

connected to the tip (usually the red wire) and ground to the sleeve.

### **Making your own microphone:**

This is easy enough to do. An electret cartridge can be salvaged from any number of sources. An old cordless phone or answering machine is the first place to look. Or you could go to your favorite discount department store and look for one of those cheap "hands free" cell phone adapters and pull it out of there. Radio Shack also sells Electret mic cartridges. While at the department store, pick up a 99 cent pair of earbuds for the cord.

Once you have the electret cartridge, all you need is a normally open push button switch and something to mount them in. A half sized Altoids tin would work and make a cute little mike. If you use the full sized standard tin, there would be room to add a battery and a audio speech clipper for improved audio punch. Lots of opportunity here to be creative.

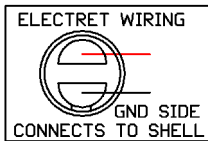

There are two half moon solder pads on the bottom of an Electret mic cartridge. Look for the one which connects to the shell of the cartridge. This is the ground pad.

### **Trouble shooting:**

Hopefully, you won't have to do any trouble shooting. If you do have to, remember that the most common reasons a kit does not work the first time are soldering problems and misplaced components. Therefore, many problems can be found simply by doing a very careful visual inspection of your workmanship. The chances of having bad parts is slim, unless they were damaged during installation. The 2N7000 are somewhat sensitive to static discharge. IC's can be damaged if put in backwards or in the wrong location, though some of them will survive this.

If you have problems, it is helpful to narrow down the area to look at the most closely. Often it is easier to determine which circuits are working properly first. Start with the audio circuits and work towards the antenna. The voltage tables shown below might help identifying problem areas.

First checks:

- Power supplies. Verify proper supply voltage to the board and output of 5 volt regulators
- Check PTO oscillator for operation and proper output frequency. If PTO not working as indicated by 1.5 volts on the source pin, most likely L2 is not wound properly or wire ends not making connection.
- Check BFO oscillator for proper operation. A general coverage HF receiver can be used for verifying the oscillator operation if nothing more suitable is available.
- Low power output: Triple check the number of turns on the low pass filter toroids. The number of turns is the number of times the wire passes through the center of the core. One extra turn on L3 can reduce the output from 6 watts to 2.5 watts!



Voltage tables:

Voltages measured with 13.8 volt supply connected. Voltages measured with 10 meg input impedance DVM. There can be some variation in the voltages you measure due to loading of the particular DVM or voltmeter you use and part to part tolerances, in particular the voltage regulators. Only be concerned if the voltages are significantly different than those shown. Pin 5, U4 voltage depends on characteristics of Electret mike element used and if it is connected.

<b>Pin#</b>	<b>U3</b>	<b>U4 Rx</b>	<b>U4 Tx</b>	<b>U8</b>	<b>U5/6</b>			<b>U7 Rx</b>	<b>U7 Tx</b>
Pin 1	1.35	0	12.2	5.0	1.40			1.40	1.40
Pin 2	0	5.0	0	5.0	1.40			3.22	3.22
Pin 3	0	0.11	0.11	5.0	0			1.38	1.38
Pin 4	0	0	0	0	3.58			1.38	1.38
Pin 5	6.71	5 to 2	5 to 2	5.0	3.78			1.40	1.40
Pin 6	13.53	0.22	0.22	5.0	5.0			0	0
Pin 7	6.58	12.15	12.15	5.0	4.54			0	0
Pin 8	1.35	13.53	13.53	13.53	5.0			0	0
		CW mode					Pin 9	4.55	0
Pin 1		0	12.2				Pin10	4.55	0
Pin 2		5.0	0				Pin 11	4.55	0
Pin 3		0.22	0.22				Pin 12	1.38	1.38
Pin 4		0	0				Pin 13	3.8	3.8
Pin 5		0	0				Pin 14	3.32	1.4
Pin 6		0.11	0.11				Pin 15	1.4	3.32
Pin 7		0	0.63				Pin 16	5.0	5.0
Pin 8		13.53	13.53						

Transistors:

	<b>C Rx</b>	<b>B Rx</b>	<b>E Rx</b>		<b>C Tx</b>	<b>B Tx</b>	<b>E Tx</b>	
Q6	5.0	3.8	3.2		5.0	3.8	3.2	
Q8	0	13.5	13.5		13.2	12.7	13.5	
Q7	0	0	0		5.0	1.4	0.7	
Q9	13.53	0	0		13.53	2.8	2.1	

Fets

	<b>D Rx</b>	<b>G Rx</b>	<b>S Rx</b>		<b>D Tx</b>	<b>G Tx</b>	<b>S Tx</b>	
Q1	0	13.53	0		0	0	0	
Q2	0	13.53	0		0	0	0	
Q3	0	0	0		0	13.5	0	
Q5	13.5	0	0		0	13.5	0	
Q4	0	0	0		0	13.5	0	
Q12	13.5	0	0		0	12.52	0	
Q14	5.0	0	0.57		5.0	0	0.57	

## Circuit description

The circuits can be divided up into several functional blocks:

1. Permeability Tuned Oscillator (PTO) – used for frequency tuning
2. SSB detector / generator and IF mixer
3. Audio stages
4. RF driver and power output amplifiers
5. T/R switching
6. CW generation

### ***PTO:***

The Permeability Tuned Oscillator (PTO) use a J310 j-fet in a Hartley configuration. This is one of the simplest oscillator circuits one can choose from and was found to be the most stable by far. However, it might not be quite stable enough to be used with digital modes such as RTTY and PSK-31. Though if the software supports AFC, it might just work if transmissions are kept short.

The frequency of the oscillator is tuned by using a brass screw inserted into the L1 coil. The coil is wound on a # 6, Nylon threaded spacer with # 32 wire. This makes a convenient coil form and has the advantage of stabilizing the tuning screw, due to the fact it is threaded. In order to limit the number of turns of wire on the spacer to a reasonable amount, an additional inductor (L2) wound on a toroid core is used in series to provide the total amount of inductance needed by the oscillator to operate at about 3 MHz. The brass screw used for tuning causes the inductance of the PTO coil to decrease as it is inserted into the coil. This of course, causes the frequency of the oscillator to increase. The mixing scheme of this transceiver is such that increasing the VFO frequency decreases the operating frequency. This results in “backward tuning” of the rig. Clockwise rotation of the tuning knob lowers the operating frequency instead of rising it.

There isn't enough tuning range to cover the complete Region 2, 40 meter band, though for those outside the USA, that isn't much of a problem. The PTO has about a 130 kHz tuning range. To get the rig to work down in the CW portion of the band, C4 is removed from the circuit. This increases the oscillator frequency and hence lowers the operating frequency of the rig. Output from the oscillator is taken from the gate of the j-fet through a small value capacitor. A dedicated 5 volt regulator is used to supply power to the oscillator. The oscillator has a few 100 Hz initial warm up drift, then settles down nicely.

### ***SSB detector / generator and IF mixer:***

This section of the circuit is comprised of two SA602 mixers, a crystal filter and a 74HC4053 analog multiplexer to switch the filter between the inputs and outputs of the mixers. During receive, U6 is used to combine an input signal coming into the rig from the antenna with the Local Oscillator frequency (generated by the PTO) to produce the IF (Intermediate Frequency) of 10.000 MHz. The IF is routed to the crystal filter through one section of the 74HC4053 analog switch. Another section of the 'HC4053 routes the output of the crystal filter to the input of the product detector mixer, U5. The filtered IF is mixed with the BFO, which uses the internal oscillator section of the mixer, to produce an audio signal.

During transmit, the signal path between the two mixers is reversed. An audio signal is applied to the input of U5, which now acts as a balanced modulator. The output of the mixer is a signal which is the sum and difference of the audio frequency applied to the input and the BFO oscillator. This is double sideband modulation. To produce single sideband modulation, the signal must pass through the crystal filter, which removes one of the sidebands and any residual carrier. In the case of this filter, lower sideband is passed and the upper sideband is removed. The 'HC4053 switches now route the signal from the output of U5, through the crystal filter and into the input of U6. U6 combines the IF with the LO to produce a signal in the 40 meter band.

The third analog switch section of the 'HC4053 is used to switch a by-pass capacitor between input pins on U5 and U6 which need to be at RF ground depending on the direction the mixer is being used for at the time. Two 2N7000 T-FETS are used for additional by-passing of the mixer inputs. During receive, Q1 AC shorts the audio input to U5 to ground, preventing noise pick up, which can show up in the received audio output. During transmit, Q4 AC shorts the antenna side input of U6 to ground, ensuring any transmit signal which might leak past the QSK switch stays out of the mixer. Because Q4 adds capacitance across the tuned input IF transformer, an additional cap to resonate the 10.7 IF transformer to 7 MHz is not required. One is shown on the circuit diagram as 0 p, in case one wants to modify the rig to work on 75 meters.

## ***Audio stages:***

During receive, the audio signal produced by U5 is amplified using op amp U4b, by a factor of 100 (10 dB) and feeds the volume control or the CW audio band pass filter. U3, a LM386 audio amplifier provides additional gain and drives the speaker. In CW mode, the CW side tone is feed into pin 3 of U3, which provides a volume control independent side tone level to the speaker. Side tone level is controlled by a trimmer, V5. Audio muting during transmit is done with a 2N7000 T-FET, which simply shunts the input to the audio amp to ground. An R/C delay on the gate slows down the turn off time. This allows the transmitter time to fully decay to zero output and gives switching transients time to settle down, which would otherwise result in audio “thumps” and clicks.

During voice transmit, audio from the microphone goes through a simple R/C high pass filter to reduce or eliminate 60 cycle hum pick up. The V1 trimmer sets the audio level going into the U5 mixer, now being used as the balanced modulator. A common Electret capacitor mike is used. Power is required to run this type of mike, and is supplied by R22.

## ***RF Driver and power amplifier:***

The transmit signal produced by the U6 mixer is buffered by an emitter follower, Q6 to drive the low input impedance of the T4 IF transformer used as part of the transmit band pass filter. Two IF transformers are connected “back to back” to form a double tuned circuit. IF transformers are used here instead of toroid coils and trimmer caps. The metal can of the transformer provides good shielding, it takes up less space than a separate toroid with capacitor trimmer and is easier to ensure it will peak at the desired frequency. The output of the band pass filter is taken from the secondary winding of T3 and then amplified by Q7. The signal is further amplified by the driver stage, Q10 to provide a signal large enough to drive the gate of the power amplifier.

The PA is a IRF-510 power MOSFET. For linear operation, it requires a bias voltage of about 3 volts. This is produced by a 5.1V zener diode for regulation with the exact bias voltage needed being set by a trimmer resistor. Bias is set so there is about 10 to 20 ma of current flowing into the PA when no drive signal is present.

The output of the PA is coupled to a Low Pass Filter (LPF) which removes harmonics and ensures proper spectral purity of the output signal. C45 connected across L3 forms a trap at the second harmonic frequency. This significantly improves the second harmonic rejection and improves PA efficiency, over what is normally achieved using a 5 pole filter. The inductance of the two coils used in the LPF are not equal, as is normally the case for this type of filter. The values were optimized to provide some impedance matching between the PA output impedance and the load. This also increases power output and PA efficiency.

## ***T/R switching:***

T/R switching is controlled by the op amp U4a. The input to the non-inverting input is set to a fixed 0.225 volts, by the resistor divider R25 and R33. The inverting input is also connected to a 22 K pull up resistor and a 10 ohm resistor to the PTT/KEY jack. When the PTT or code key is closed, the voltage on the inverting input changes from 6 volts to near zero volts. The output of U2b now goes from its normally low state to a high state. Q12 is used to invert the polarity of the op amp output, as both normally low and normally high states are needed for control.

When in the normally low state for receive, Q1 is turned on, shunting audio from the microphone to ground. Q4 is turned off, allowing signals from the antenna to pass into the U6 mixer. Q14 is also turned off, allowing audio to pass into the audio amp. Q9 is turned off, so there is no voltage is going to the transmitter amplifier stages. Finally, Q2 is on, while Q3 is off, allowing signals from the antenna to pass into the receiver input transformer.

When the output of U4a changes to the high transmit state, Q1 is turned off, allowing audio from the microphone to pass into the balanced modulator, Q4 is turned on, by-passing the antenna input of the U8 IF mixer to ground, Q14 is turned on, muting the audio output, Q2 is turned off and Q3 is turned off, isolating the receiver input transformer from the transmitter output signal. Q9 is turned on, supplying power to the PA bias circuit and the transmitter stages through R12. C62 slows down the turn on time of the transmitter stages to provide leading edge wave shaping of the CW transmit signal to prevent key clicks.

The switch direction control pins for the 74HC4053 are connected to an R/C delay circuit and turned on and

off through an isolating diode which is connected back to the output of U2b. When the rig goes into transmit, the control pins are pulled low through the diode. This causes the switches to immediately switch to the transmit configuration. When the rig switches back to receive, C39 in combination with R11 delays the switching back to the receive configuration by a few milliseconds. This ensures that the transmit signal is still being generated as the transmit amplifiers ramp down. This is important when CW mode is being used so that proper CW wave shape generation is produced.

### ***CW generation:***

The simplest way to make a SSB rig operate CW is to use a tone oscillator connected to the audio input. A single audio tone will produce a single output frequency. Otherwise, the BFO frequency would have to be shifted during transmit so that the carrier falls into the pass band of the crystal filter, instead of being filtered out as it normally is for SSB operation. Shifting the BFO can be a little complicated and since we need a tone oscillator for side tone anyway, we might as well use that. The tone oscillator is a "twin T" configuration and produces about a 600 Hz tone with the values shown.

CW operation is enabled by simply plugging a mono plug into the microphone jack. This grounds the resistor supplying voltage to the mike element. An op amp senses that this voltage is at ground potential and causes its output to go from a normally high state to a low state. This output is connected to the emitter and base resistor of the tone oscillator. Now, when the transmitter is keyed, the full keyed supply voltage for the transmitter circuits appears across the tone oscillator, turning it on. A diode is in series with the collector resistor for the tone oscillator transistor. This keeps the voltage coming from the op amp from back feeding through the bias resistors and transistor diode junctions into the keyed transmitter voltage line and tuning on the QSK fets.

Schematic

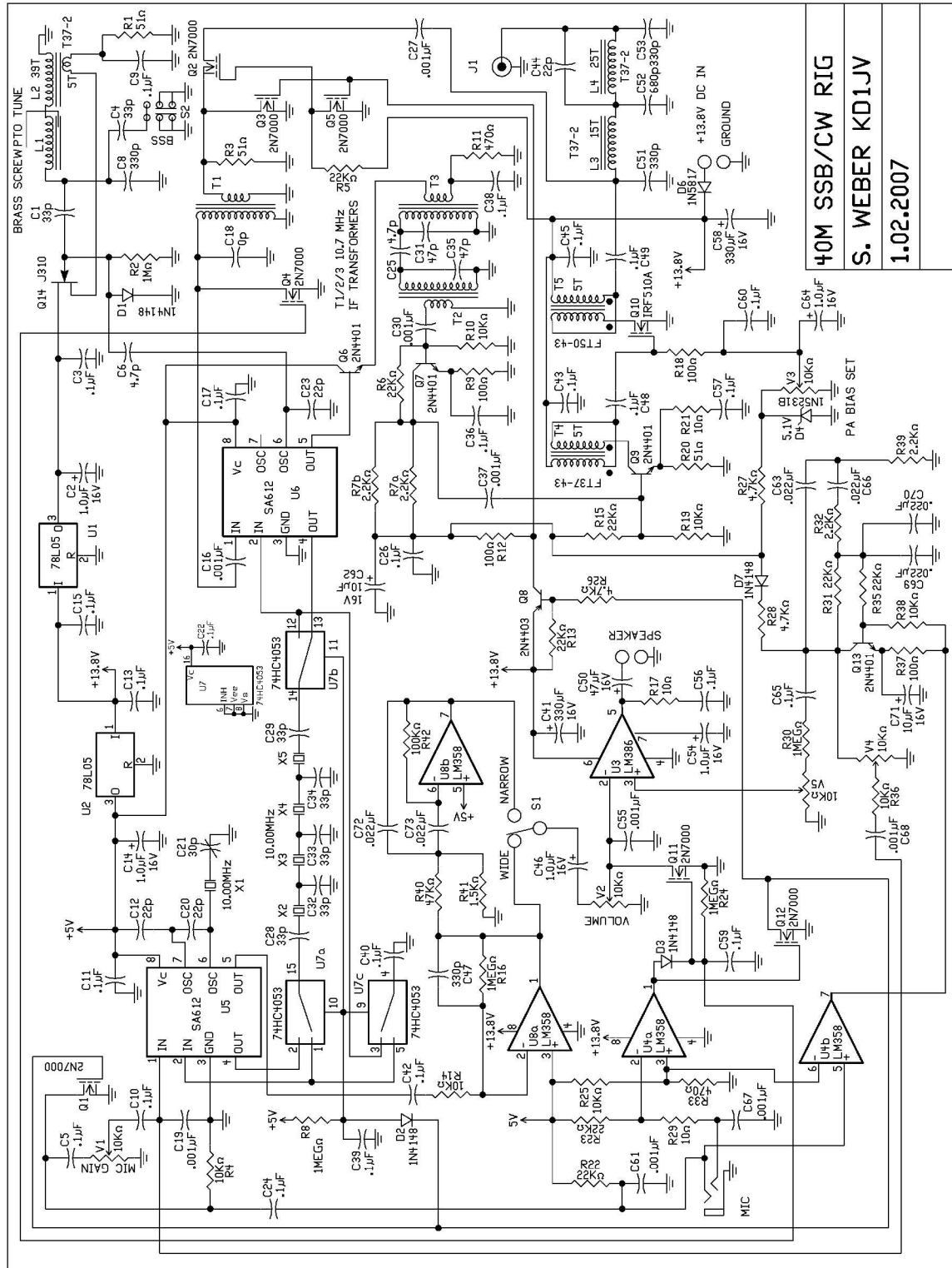

Note: diode RF detector parts not shown on schematic.

## Errata for MMR-40 3-13-07

1. If counting turns on L1, the PTO coil, there should be 39 not 29.
2. Values shown for R29 and R33 on layout diagram are reversed. R29 should be 10 ohms, not 470 and R33 should be 470 ohms, not 10. Values listed correctly in parts placement chart.
3. 5 p caps were supplied with the kit instead of 4.7 p
4. D4 is called out as a 1N5232B zener. A different type is supplied with the kit and is marked 231B.
5. Components used in the diode RF voltage detector are not shown on schematic. They are listed in the parts placement chart.
6. On the schematic, R43 should be labeled R42. Value of R36 and R38 should be 10 K not 22 K.
7. If L2 is installed incorrectly, the PTO frequency will be about 500 kHz higher than it should be. To help keep track of which leads are the main winding and which are the feedback turns, make one set of leads longer than the other. (and remember which ones are which).
8. When measuring the drive voltage at the gate of Q10, if the voltage does not go to zero when V4 is turned full counter clockwise, the BFO trimmer is not yet set correctly and carrier is leaking through the crystal filter. Tweak the BFO trimmer slightly until the voltage at the gate goes to or near zero by turning it towards min capacitance. There is something of a compromise here, in order to keep the amount of carrier transmitted to a minimum and retaining low frequency response of the received and transmitted audio.

## Assembly of the MMR-40 and KD1JV Digital Dial into the aluminum chassis

Check the kit against this parts list.

- 1 – Chassis top and bottom
- 1 – KD1JV Digital Dial Kit
- 2 - small Norcal knobs
- 1 - 15pF disk capacitor
- 1 – new C46, 1uF 25v capacitor
- 1 – new D6, 1N5817
- 2 – 1/8" stereo audio jacks w/mounting rings
- 1 – 10k audio taper pot w/switch
- 1 – speaker
- 2 – speaker mounting brackets
- 2 – 4-40 x 3/8" SS flat head screws (speaker)
- 1 – red acetate plastic window
- 1 – BNC panel mounted female
- 1 – 4" bail wire kit (bail wire, 2 blocks, 2ea. 4-40 x 1/4" pan head SS screws)
- 8 – 4-40 x 1/4", SS pan head screws (4- for main pc board), (4- for dd board)
- 1 – #4 nylon insulating washer
- 8 – 4-40 x 1/4" SS flat head screws (for chassis halves)
- 4 – 1/4" high self adhesive rubber feet
- 2' – 22awg hook up wire
- 1 – MMR-40 decal kit

Assembling a new pc board, or retrofitting an existing plastic chassis mounted pc board will require some deviation from the original assembly instructions. These changes are described below. Certain board mounted components will be removed and replaced by supplied chassis mounted equivalents, and the power supply line is tapped and spliced to allow the switch on the volume control potentiometer to work properly.

Additionally, the digital dial has one deviation from the original assembly instructions. This involves moving the trim capacitor to the back side of the board so access is allowed when it's installed.

- Apply your decals to the front and rear panel. When placing the decals, be sure to leave clearance for the knobs as shown.



- The decals are applied the same as the old model airplane decals. Cut around each group of text you wish to apply, leave a border. It doesn't have to be perfect as the background film is transparent. Place the decal in lukewarm water for 10 seconds. Handle carefully to avoid tearing. Gently slide the decal into place on location. Use a damp cloth to wipe excess water. Remove any bubbles by wiping gently to the sides. Allow to set 3 hours, or speed drying by placing near a fan. After drying spray Krylon clear to seal and protect the decals, and allow to dry. There are two complete decal sets for this project, if you mess one up.

- Mount the bail to the outside of the chassis bottom, using 2ea. 4-40 x 3/16" pan head screws.

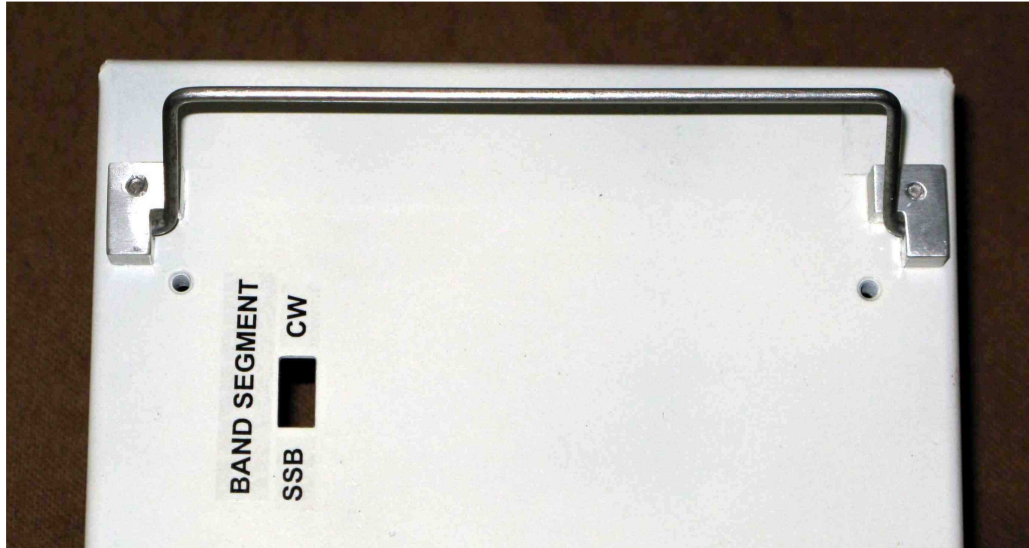

- Tape the red acetate film to the inside of the front chassis, some trimming will be required to clear the mounting Pem's.

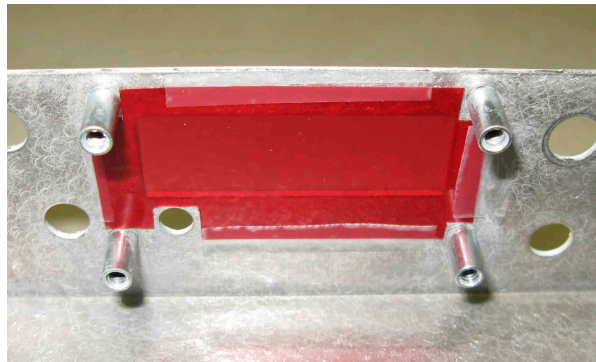

- Assemble the digital dial or modify your existing one to move the trim capacitor to the side opposite the display. Solder a wire to the signal input and another to the positive power input of the digital dial, on the side opposite the display. There is no need for the ground wire, the chassis mounting will complete that connection. It can now be mounted to the chassis using 4ea. 4-40 x 1/4" pan head screws.

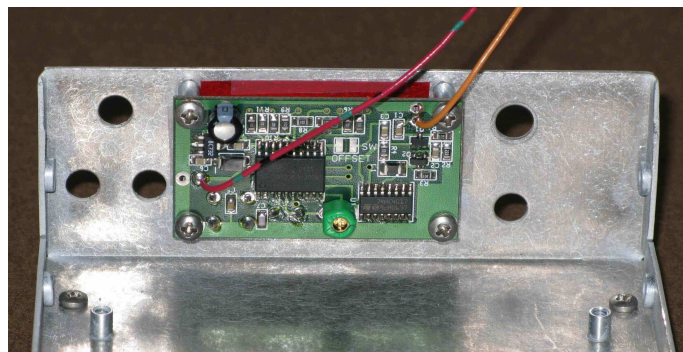



Prepare your pc board as follows:

- Unsolder the speaker wires from the speaker.
- Locate D6. This is a protection diode for an incorrectly connected power supply. Unsolder the cathode end (banded) and stand on end. Solder a 8" long wire to the pad just vacated and another 8" long wire to the band end of the diode up in the air. These two wires will go to the switch contacts on the supplied 10k volume/switch pot. Locate the Local Oscillator pad, marked "LO" and solder 1 leg of the supplied 15pF capacitor to the pad, the other leg straight up for later connection.

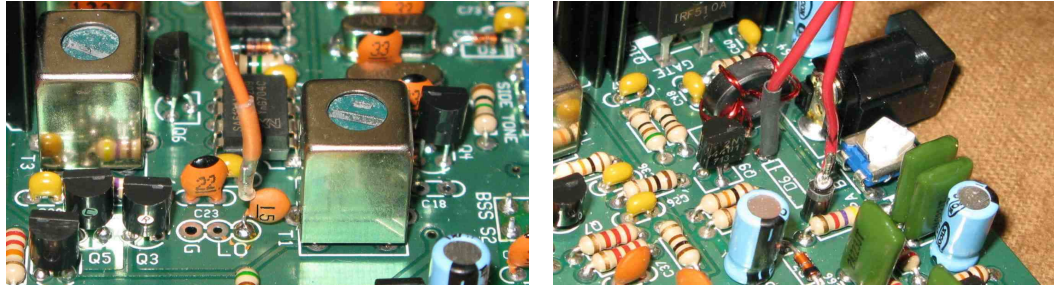

- Remove C46, and install under the board, laying flat against the board. This will give you more clearance for the digital dial, and connecting wires.

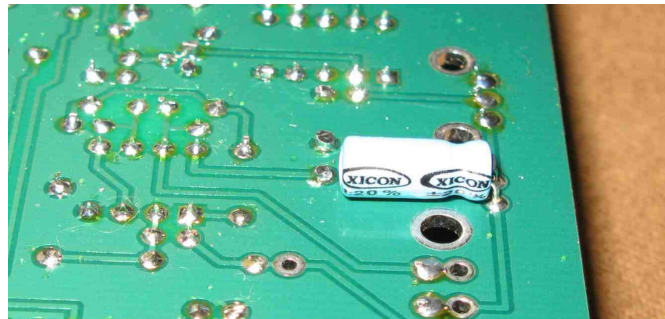

- Remove the board mounted BNC connector, volume control, filter slide switch, and microphone jack. The board mounted power jack is not removed.
- Connect the remote mounted volume control, filter toggle switch, microphone jack, and key jack to the pc board prior to board mounting. They are wired like their board mounted equivalents, with the exception of the microphone and key jacks. They are now separated to two jacks. Connect the two jacks in parallel to the points marked on the PCB.

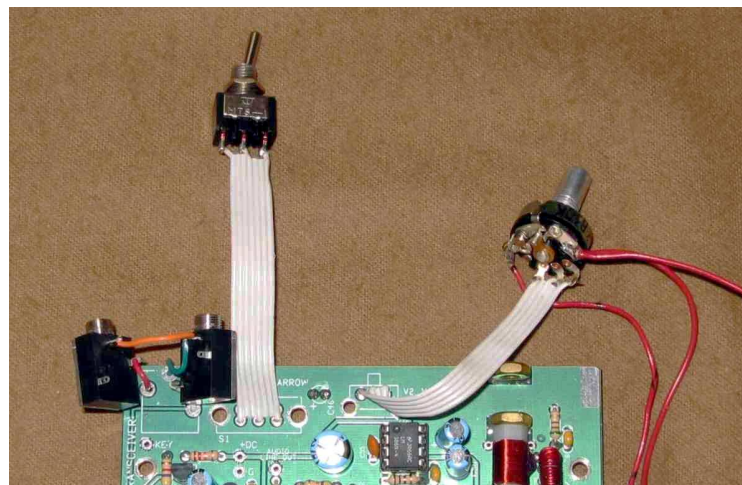

- Mount the pc board using 4ea. 4-40 x 1/4" pan head screws. Use the #4 nylon washer under the screw head near R26, as there is a trace that needs insulating from ground if the solder mask fails.



- Mount the volume control, toggle switch, mic. and key jacks.

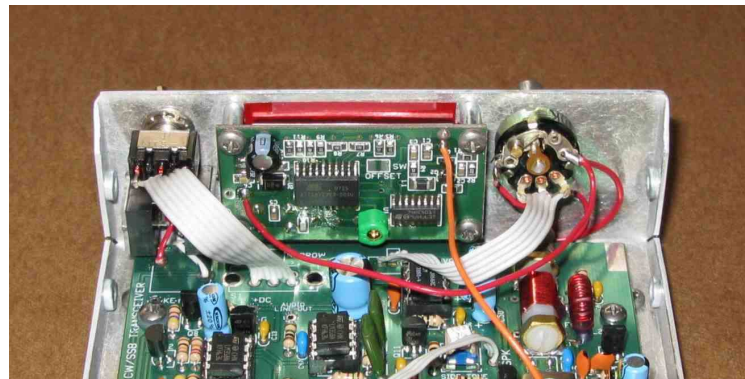

- Connect the two power wires from D6 to the volume control switch connections. Connect the power connection to the digital dial to the switched side of the volume control/switch.



- Connect the signal input wire of the digital dial to the flying lead of the 15pF capacitor connected to the Local Oscillator pad.



- Mount the new BNC connector to the rear panel, and wire to the board pads just below the connector.



- Mount the speaker to the top cover using 2ea. 4-40 x 5/16" flat head screws and the supplied Pem nut retainers, and connect the speaker wires.



Assemble the cover to the base, using 8ea. 4-40 x 1/4" flat head screws.  
Replace the knobs to the front panel, and attach the four rubber feet to the corners of the chassis.

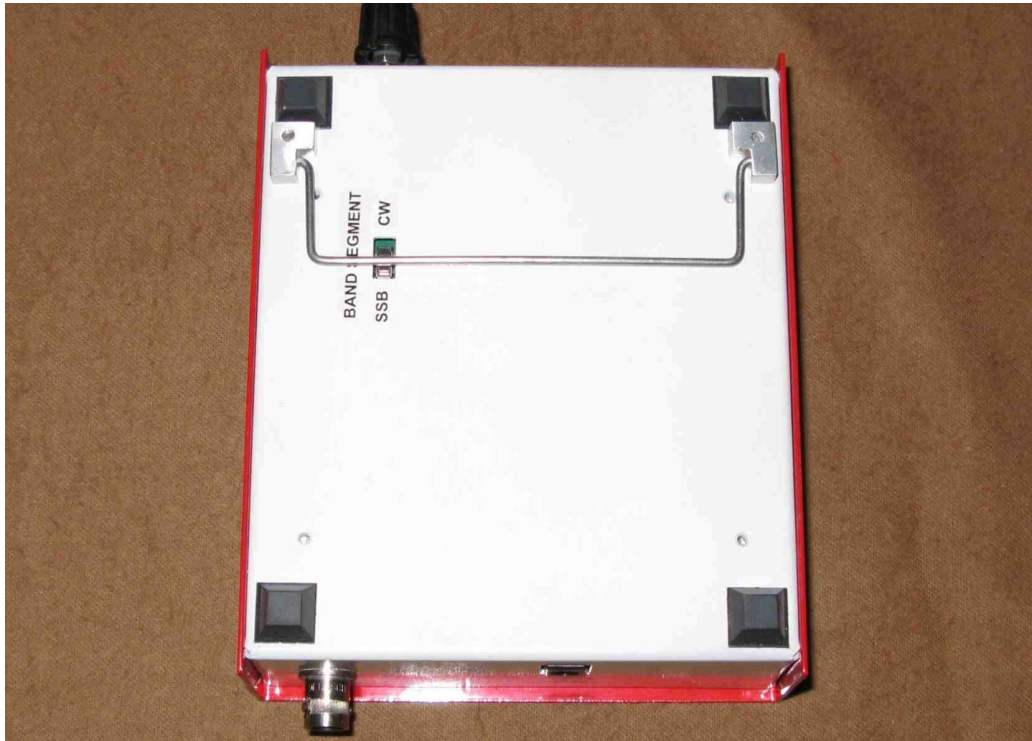

Ken – WA4MNT

mmr40 chassis 120808.pdf

DC IN



ANTENNA



QRPKITS.COM

40 M CW/SSB TRANSCEIVER

TUNE



FILTER



CW

SSB



MIC/KEY

VOLUME



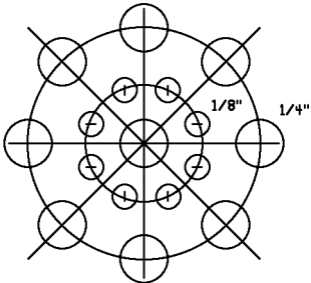

**SPEAKER DRILL HOLE PATTERN**