

# Quartz-Synthesized Communications Receiver



**DX-302**

**OWNER'S  
MANUAL**

PLEASE READ BEFORE  
USING THIS EQUIPMENT

**REALISTIC®**

**CAT. NO.  
20-220**

CUSTOM MANUFACTURED FOR RADIO SHACK  A DIVISION OF TANDY CORPORATION

**... It All Comes Alive on Your  
Realistic DX-302 Communication Receiver**

The entire world is at your fingertips with the Realistic DX-302. English language broadcasts can be heard from such world capitals as London, Tokyo, Paris, Rome, Berlin and Moscow. Exotic music and unusual languages can be heard from stations located in distant, isolated sections of the world. You might listen in as the Coast Guard aids a vessel in distress, or perhaps eavesdrop as the skipper of a fishing boat radios back news of the day's catch. Airplanes, both civilian and military, use radio to keep in touch on intercontinental flights. Radio amateurs (commonly known as "hams") can be heard chattering away around the clock with friends located in the next town or on the other side of the world.

Your DX-302 is designed to tune a wide variety of signals from 10 kHz to 30 MHz. It receives AM (Amplitude modulation), CW (Continuous wave, better known as Morse code) and SSB (Single side-band) signals. It also has superb sensitivity and selectivity to dig out distant and low-powered stations.

The synthesized drift-cancelling triple-conversion mixer system provides thirty tunable ranges from 10 kHz to 30 MHz, and is derived from a single 4 MHz quartz oscillator. This results in precise frequency control and superior frequency stability. A stable low frequency kHz Tuning circuit covers the 1 MHz increments and the 5-digit display shows the exact frequency.

The DX-302 uses 39 transistors (10 of which are field-effect type), a Large-Scale-Integration IC frequency counter, 3 integrated circuits, 32 diodes, 5 seven-segment LED displays and six LEDs.

You can use the DX-302 at home (on 120 Volts AC for USA/CANADIAN models and 220/240 Volts for EUROPEAN/AUSTRALIAN models or 12 V DC [8 "C" cells] ) or in your car or vehicle (12 Volts DC negative ground).

For your own protection, we urge you to record the Serial Number of this unit in the space provided. You'll find the Serial Number on the back panel of the unit.

Serial Number

**Main features are:**

- Quartz controlled frequency synthesizer
- Continuous frequency coverage from 10 kHz to 30 MHz
- Large digital frequency display
- Triple conversion circuitry
- Six element and nine element ceramic filters provide outstanding selectivity (freedom from adjacent channel interference)
- Dual MOS Field-effect transistor in the critical mixer stage (freedom from cross-modulation and undesirable RF distortion)
- All-silicon solid-state circuitry for maximum circuit efficiency with minimum noise
- Audio power IC provides high intelligibility sound
- AC or DC (negative ground) operation
- If the AC power should fail, an automatic circuit switches over to the battery power with no interruption of sound

The DX-302 uses a Wadley Loop synthesized circuit for continuous frequency coverage. With this design it is normal to find beat notes on such frequencies as 910 kHz and 1 MHz. Such beat notes indicate your DX-302 is working properly. The effects of such beat notes can be reduced simply by trying a different external antenna or readjusting the outer (MHz) tuning knob.

**RADIO SHACK LIMITED WARRANTY**

This equipment is warranted against defects for 1 year from date of purchase. Within this period, we will repair it without charge for parts and labor. Simply bring your sales slip as proof of purchase date to any Radio Shack store. Warranty does not cover transportation costs. Nor does it cover equipment subjected to misuse or accidental damage.

This Warranty gives you specific legal rights and you may also have other rights which vary from state to state.

*We Service What We Sell*

**WARNING: TO PREVENT FIRE OR SHOCK HAZARD, DO NOT EXPOSE THIS RECEIVER TO RAIN OR MOISTURE.**

## SPECIFICATIONS

|   |  |   |   |   |                 |
|---|--|---|---|---|-----------------|
| <b>SEMICONDUCTOR<br/>COMPLEMENT:</b>                          | 1 LSI C-MOS Frequency Counter IC,<br>3 integrated circuits, 39 transistors,<br>32 diodes, 5 7-segment LED displays,<br>6 LEDs and 1 thermistor |   | <b>IMAGE RATIO:</b>                         | 100 kHz   | 70 dB           |
| <b>RECEIVING SYSTEM:</b>                                      | Quartz controlled synthesizer, triple-<br>conversion   |   |   | 300 kHz   | 70 dB           |
| <b>FREQUENCY COVERAGE:</b>                                    | 10 kHz to 30 MHz   |   |   | 900 kHz   | 70 dB           |
| <b>PRESELECTOR BANDS:</b>                                     | 0.01 – 0.15 MHz (10 – 150 kHz)<br>0.15 – 0.5 MHz (150 – 500 kHz)<br>0.5 – 1.6 MHz<br>1.6 – 4.5 MHz<br>4.5 – 12 MHz<br>12 – 30 MHz              |   | <b>SELECTIVITY:</b>                         | 3.1 MHz   | 60 dB           |
| <b>FREQUENCY DISPLAY:</b>                                     | Digital read-out in five 7-segment<br>LEDs   |   |   | 7.1 MHz   | 60 dB           |
| <b>SENSITIVITY<br/>(for 10 dB Signal-to-Noise<br/>ratio):</b> | AM   | 50 kHz 30 $\mu$ V<br>300 kHz 2 $\mu$ V<br>900 kHz 1 $\mu$ V<br>3.1 MHz 0.5 $\mu$ V<br>7.1 MHz 0.5 $\mu$ V<br>15.1 MHz 0.5 $\mu$ V<br>28.1 MHz 0.5 $\mu$ V   | <b>RECEPTION MODE:</b>                      | 15.1 MHz  | 60 dB           |
|   | SSB  | 50 kHz 15 $\mu$ V<br>300 kHz 1 $\mu$ V<br>900 kHz 0.5 $\mu$ V<br>3.1 MHz 0.3 $\mu$ V<br>7.1 MHz 0.3 $\mu$ V<br>15.1 MHz 0.3 $\mu$ V<br>28.1 MHz 0.3 $\mu$ V |   | 28.1 MHz  | 60 dB           |
|   |  |   | <b>I.F.:</b>                                | -6 dB -60 dB  |                 |
|   |  |   |   | WIDE  | 3.5 kHz 6.0 kHz |
|   |  |   |   | NARROW  | 2.5 kHz 4.0 kHz |
|   |  |   | <b>BEAT FREQUENCY:</b>                      | 455 kHz $\pm$ 1.5 kHz   |                 |
|   |  |   | <b>BFO PITCH:</b>                           | $\pm$ 1 kHz   |                 |
|   |  |   | <b>FREQUENCY STABILITY:</b>                 | Within 1 kHz per hour after 60<br>minutes warm up.<br>Within 2 kHz during 10 minutes after<br>initial turn on.  |                 |
|   |  |   | <b>AUDIO OUTPUT (8<math>\Omega</math>):</b> | 1.5 watts maximum   |                 |
|   |  |   | <b>ANTENNA IMPEDANCE:</b>                   | 50 ohms for coax connector Hi-Z for<br>long wire  |                 |
|   |  |   | <b>POWER REQUIREMENTS:</b>                  | AC – 120 volts, 60 Hz (220 – 240 volts,<br>50 Hz for European/Australian<br>models), 15 watts maximum<br>DC – 8 "C" cell or external 12 volts<br>negative Ground only, 8 watts maxi-<br>mum |                 |
|   |  |   | <b>DIMENSIONS:</b>                          | 6 x 14-1/2 x 10" HWD<br>(146 x 362 x 252 mm.)   |                 |
|   |  |   | <b>WEIGHT:</b>                              | 13-1/5 lbs. (6 kg)  |                 |

# GETTING TO KNOW YOUR DX-302

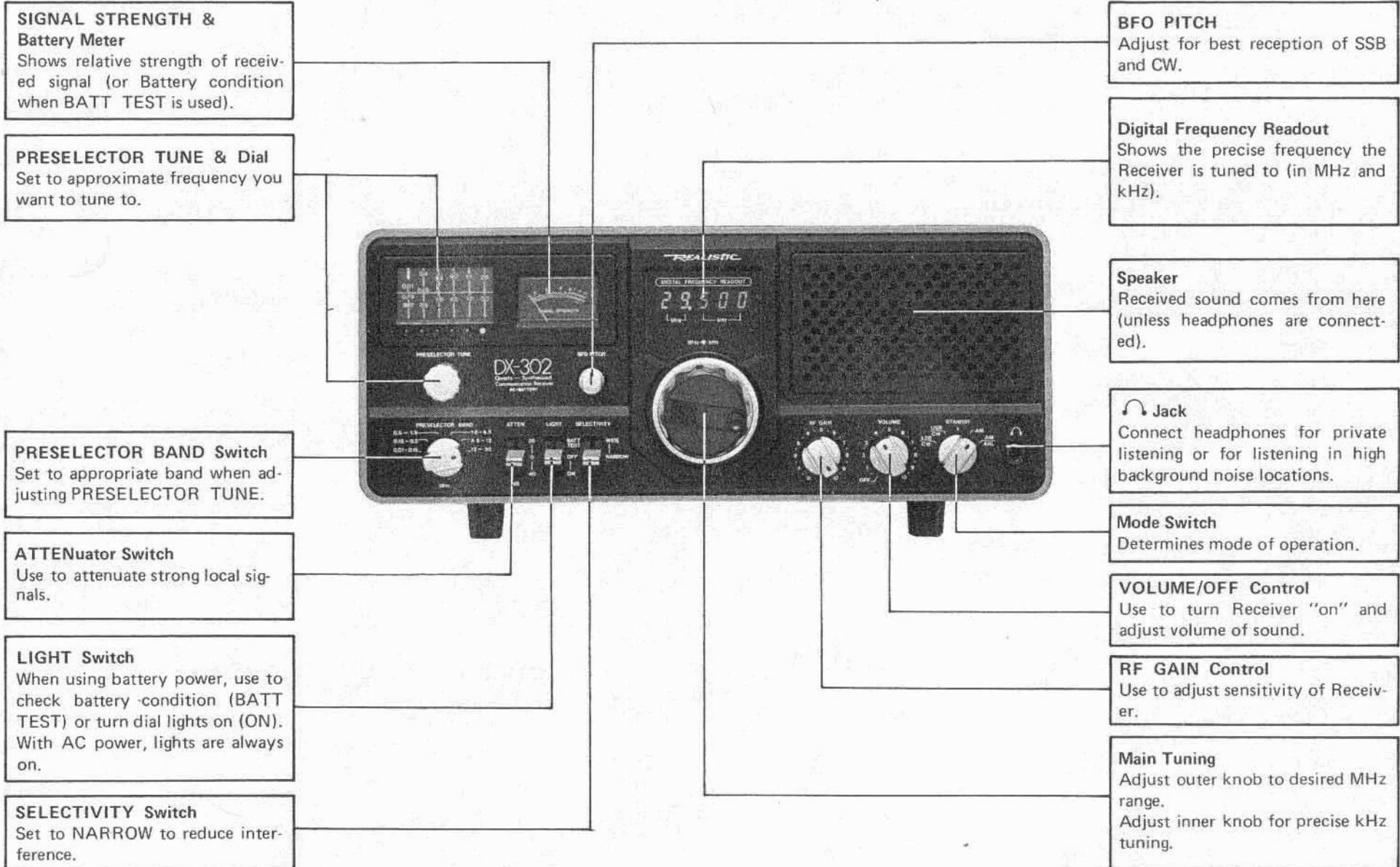

**Cord Wrapping Posts**  
Use to wrap the AC Power Cord for storage or when operating from Battery power or external 12 V DC. (Screw posts into back of Cabinet.).

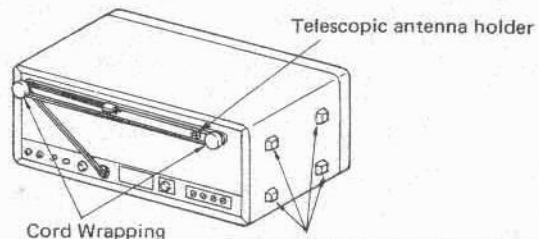

Cord Wrapping Plastic Posts

Rubber Feet are provided in case you use the Receiver in portable operation. Peel off of paper backing and press onto Left hand side of Cabinet.

**Battery Compartment**  
To operate from battery power, load 8 heavy-duty "C" Batteries here.

**External Speaker Jack**  
Connect an external speaker to this jack (automatically disconnects built-in speaker).

**KEY Jack**  
To practice Morse Code, plug a code key into this jack, tune Receiver to 1 or 2 MHz and set Mode to USB/CW or LSB/CW.

**TAPE OUT Jack**  
Connect a tape recorder to this jack and record messages off-the-air.

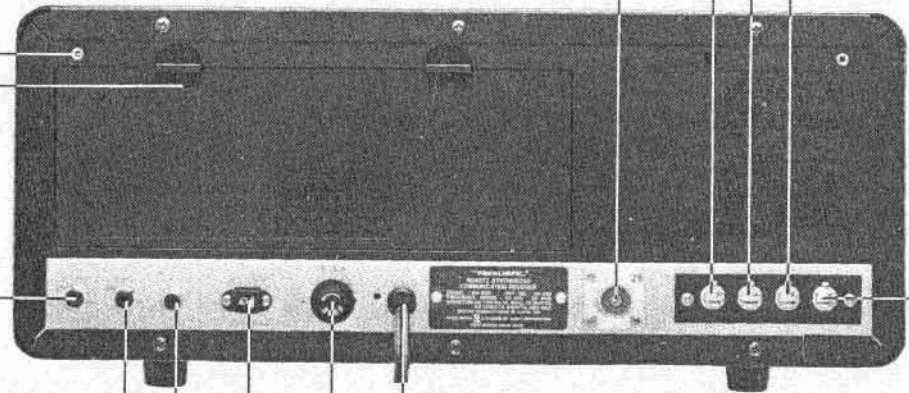

**Coax ANTenna Connector**  
Connect 50 – 75Ω antenna lead in to this.

**ANTenna Screw Terminal**  
Connect long-wire antennas to this screw terminal.

**GROUND Screw Terminal**  
Connect a wire between one of these screws and a good ground point. The other is for MUTE operation.

**MUTE Screw Terminal**  
Can be used for remote muting of the Receiver (without using STANDBY Mode switch position). To Mute, connect to a GND screw.

**Power Cord**  
Connect to a standard AC outlet.

**FUSE**  
Protects the unit from abnormally high current. Use only a 0.5 Amp type.

**DC 12V Jack**  
For operation from an external source of 12 volts DC, connect red wire to + and black wire to -.

## INSTALLING YOUR RECEIVER

Your Realistic DX-302 is a communications Receiver designed and manufactured to the most rigid quality standards. It has been packed to ensure safe arrival. Carefully lift the unit out of the shipping carton and inspect for any visible damage.

Decide where you want to set up the Receiver. In making your decision you should consider:

1. **YOUR COMFORT.** You will spend many hours with your Receiver; be sure it is placed where you can enjoy it at any time.
2. **YOUR ANTENNA.** For immediate operation you can use any simple antenna. However, to realize the maximum performance, you will need a long wire short wave antenna (such as Radio Shack's 278-758) or a special antenna such as we discuss later on. In any case, it should be an outside antenna.
3. **YOUR GROUND.** If you set up an outside antenna, for safety you should connect a ground wire to the Receiver. This will require running a ground wire from the ground screw connection on the back of the Receiver to a metal cold water pipe or metal pipe driven into the earth.

## ANTENNAS

A suitable antenna is vital to get maximum performance from your DX-302. We've provided two antennas with your Receiver. One is a simple back-of-the-set telescopic antenna which is handy for portable use. You'll find that this antenna can often do a good job, particularly when receiving more powerful stations.

Also included with your DX-302 is a 33-foot (10-meter) long-wire antenna. You can use this as a temporary antenna away from your normal listening location. If you are an apartment dweller and can't erect an outside antenna, you can obtain satisfactory reception by letting the wire hang from a window. Be sure to avoid metal surfaces and electrical wires, and pull in the wire when not listening to your DX-302. In wood frame apartments, good reception can be obtained with the wire completely indoors.

But for the very best reception you'll need an outdoor antenna. Unfortunately, there is no single antenna which will give top performance throughout the 10 kHz - 30 MHz range of your DX-302. One type of antenna which is a good compromise choice for most listening is the longwire. As the name implies, the longwire is a long length of wire (usually 50 to 100 feet [15 m to 30 m]) mounted as high as possible. Your local Radio Shack has a shortwave antenna kit (278-758) which contains everything you need to erect a longwire antenna. You can also purchase the needed items individually at your Radio Shack store if you desire.

The longwire is erected as shown in the diagram below. Be especially careful to avoid running any portion of the antenna or lead-in wire over or under electric lines. The static discharge unit is important to help prevent damage to your Receiver from close (not direct) lightning strikes. Your Radio Shack store also has these available.

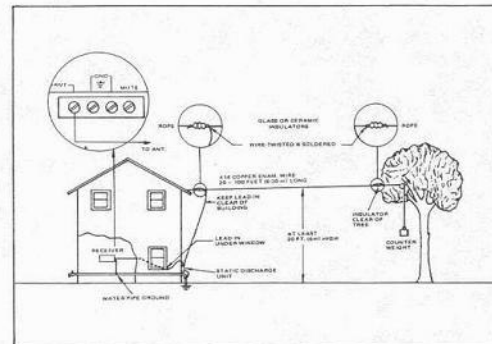

For the best reception on a particular band, you should install a dipole antenna. A dipole must be of a specific length, determined from either of these two equations:

$$\frac{468}{\text{Frequency in MHz}} = \text{Length in Feet}$$

$$\frac{142}{\text{Frequency in MHz}} = \text{Length in Meters}$$

Note in the illustration that a dipole requires three insulators, one at each end and another in the middle of the antenna. The lead-in must be coax cable of 50 – 75 ohms, such as RG-58/U or RG-59/U. The center wire of the coax is attached to one half of the dipole while the shielding braid is attached to the other. Your DX-302 comes equipped with a coax ANT connector for dipoles. You can obtain coax cable and all other components for a dipole at your local Radio Shack. Dipoles generally provide excellent reception on the bands they are intended to cover, but performance is often poor on other bands.

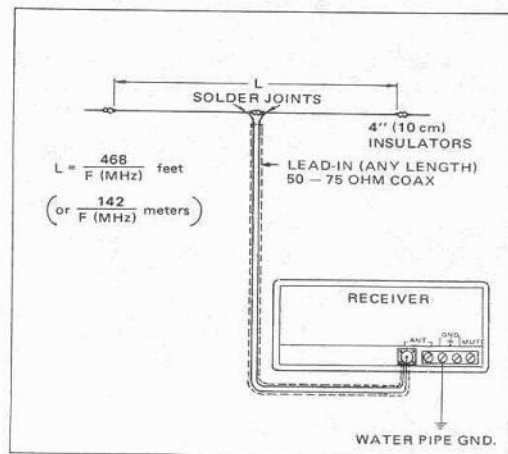

#### Dipole Lengths for Popular Bands

- 80 Meter Ham Band = 117 feet (35.6 m)
- 60 Meter Broadcasting Band = 95 feet (28.9 m)
- 49 Meter Broadcasting Band = 76 feet (23.3 m)
- 40 Meter Ham Band/
- 40 Meter Broadcasting Band = 66 feet (20 m)
- 31 Meter Broadcasting Band = 49 feet (14.8 m)
- 25 Meter Broadcasting Band = 40 feet (12.2 m)
- 20 Meter Ham Band = 33 feet (9.7m)
- 19 Meter Broadcasting Band = 31 feet (9.4 m)

## GROUNDING

To insure best reception, you must always connect a Ground wire to one of the **GND** screws on the back of the Receiver. Use a heavy gauge wire for this. Connect the other end either to a metal cold water pipe (**not** hot water and **not** natural gas pipe) or to a metal rod driven into the ground. Or, you can bury a copper plate or copper screen in the ground and make connection to it.

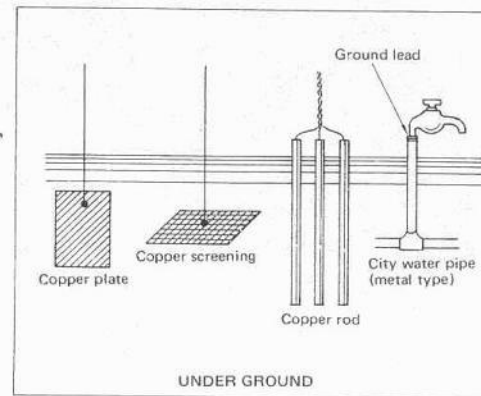

## OPERATION

Before operating your DX-302, you should have an antenna and ground connected. And, of course, you must either have the power cord connected to a standard AC outlet or load 8 type C batteries (open Battery Compartment and install batteries as illustrated). Or, connect the DC power cord to a source of 12 volts DC.

Since you probably are most familiar with the standard broadcast band radio reception, you might prefer to use the DX-302 there first.

1. Turn the Receiver on by rotating **VOLUME** clockwise.
2. Set **Mode** Switch to AM.
3. Set **PRESELECTOR BAND** Switch to 0.5 ~ 1.6.
4. Set **ATTEN** and **LIGHT** to their center positions and **SELECTIVITY** to upper position.
5. Set **RF GAIN** to 10.
6. Adjust **MHz** Tuning so 1. appears in the **Digital Frequency Readout**.
7. Use **kHz** Tuning to tune in a station above 1.000 MHz.
8. Adjust **PRESELECTOR TUNE** to the same frequency (adjust for maximum reading on the **Meter**).
9. To tune in stations below 1.000 MHz, adjust the **MHz** Tuning so a 0. appears in the **Readout**. Then adjust **kHz** Tuning for the desired station frequency. Once again, adjust **PRESELECTOR TUNE** to the same frequency (for maximum reading on the **Meter**).
10. Often you can peak-up the sensitivity by slightly readjusting the **MHz** Tuning. Try it.

### Tuning VLF and LF Frequencies

Once you've become familiar with the DX-302 operation on the standard Broadcast Band frequencies, you can try the low frequencies from 10 kHz up to 500 kHz.

1. Set **PRESELECTOR BAND** Switch to the appropriate position to cover the frequency you will tune. When you use the 0.01 ~ 0.15 MHz position, set **PRESELECTOR TUNE** to the "SET" position.
  2. Set **PRESELECTOR TUNE** to the approximate frequency you will tune to (unless tuning the 0.01 ~ 0.15 MHz spread [for this coverage, leave at "SET" position]).
  3. Set **MHz** Tuning so 0. is displayed.
  4. Set **kHz** Tuning to display the desired frequency.
  5. Try readjusting **MHz** Tuning slightly for maximum sensitivity.
  6. If not on 0.01 ~ 0.15 MHz position of **PRESELECTOR BAND**, adjust **PRESELECTOR TUNE** for maximum signal reception.
- See "Special Operating Notes" later on.

### Tuning Frequencies Above 2 MHz

The rest of the bands are quite easy to tune.

1. Set **PRESELECTOR BAND** Switch to the appropriate position.
2. Adjust **PRESELECTOR TUNE** to the approximate frequency you are going to tune to.
3. Adjust **MHz** Tuning to display the desired MHz number.
4. Adjust **kHz** Tuning to display the desired kHz number.
5. Adjust **PRESELECTOR TUNE** for maximum signal reception.
6. If you are tuning for SSB (single sideband) or CW (continuous wave, or "code" as the more common term is), set **Mode** Switch to LSB/CW or USB/CW and **SELECTIVITY** switch to **NARROW**. Adjust **BFO PITCH** to precisely tune in the signal.
7. Often for optimum sensitivity you'll find that it helps to make a slight readjustment of **MHz** Tuning.
8. If you are in the AM mode and noise is excessive, set **Mode Switch** to AM/ANL position.



## SPECIAL OPERATING NOTES

Your DX-302 is a fine example of technical achievement in the field of communications equipment. It is simple to operate, and yet has all the most-wanted features and controls — plus the fact that it is a continuous — coverage receiver (tunes ALL frequencies from 10 kHz to 30 MHz). Short Wave Listening is a great hobby — your skill will grow with experience and of course experience only comes with practice. This section has a number of hints relating to the proper use of your Receiver. We can't possibly turn you into an expert SWL just by giving you thorough instructions — but these hints will help.

The Antenna connection can affect reception in unusual ways on a Receiver of this design. Because the Preselector/RF stages are not automatically tracked with the oscillator, it is possible that strong local signals will produce spurious reception effects.

For example, long wires of 50 feet (15 m) or more connected to either of the ANTenna terminals can deliver a very high RF signal to the back of the set. The result is a tendency to overload the input and you tune spurious responses.

Solutions to this type of effect:

1. Be sure **PRESELECTOR BAND** Switch is set to the approximate position of the band you wish to receive. Tune **PRESELECTOR TUNE** for maximum signal reception.
2. Try turning down the **RF GAIN** control.
3. Try readjusting **MHz** Tuning very slightly.
4. Try switching in the **ATTEN** (use 20 dB position first, then 40 dB if necessary).
5. Try connecting the antenna to the other **ANTenna** connector.
6. Use a shorter antenna when operating below 2 MHz.

Preselector setting and tuning is important for best sensitivity and maximum spurious-signal rejection. Always be sure the **PRESELECTOR BAND** is set correctly for the frequency you are tuning to. If you detune the Preselector, the S-meter reading will drop. If you set the **PRESELECTOR BAND** Switch to the wrong position, you may not completely lose reception of the signal; but this does not imply that this signal will be received at another frequency. An improper setting of the Preselector may result in false signal tuning. Proper setting and tuning of Preselector will help to eliminate crossband reception problems.

MHz Tuning does have a slight effect on the sensitivity of the Receiver. For optimum reception, tune for best sensitivity (and minimum spurious response). You'll note that above the extreme upper end of any given MHz spread, the kHz display will blank out, although you can still tune in signals for about 30 kHz. This allows you to tune both above and below the MHz band "edges" without having to change MHz tuning. The same is true for below the extreme low end of each MHz spread.

Operation of the **RF GAIN** control effects the overall sensitivity of the Receiver. Normally you'll want to leave **RF GAIN** at maximum (10). If you are near a very strong signal, you can use **RF GAIN** to reduce the volume of the received signal; if you don't do this, the strong incoming signal can "swamp" the input stages of the Receiver and may result in unusual types of signal reception and distortion problems. Also, you should realize that the **S-Meter** is accurate only when **RF GAIN** is set to maximum.

The **Mode** Switch determines the type of signal that your Receiver recovers. For standard broadcast and international short wave signals, use the **AM** position. For code or SSB signals, use either **USB/CW** or **LSB/CW** position. If pulse-type noise interferes with reception of AM signals, use the **AM/ANL** position. You may notice that with the **AM/ANL** position (Automatic Noise Limiter), the signal reception seems to drop slightly; this is normal (thus it is best not to use the **ANL** mode unless noise is a serious problem).

When tuning SSB and code signals, adjust the kHz tuning control very slowly. In the Ham bands, much of the activity is in code or SSB. If the SSB signal is very strong, proper reception will be improved if you adjust **RF GAIN** away from maximum. If you tune through an SSB signal and you are in the AM mode, there will only be a fluttering sound (you'll be able to tell that a signal is there, but won't be able to understand anything). Use one of the SSB modes and slowly adjust the kHz Tuning and/or **BFO PITCH** until the voice sounds are normal. When improperly tuned, voices will have a low guttural sound or will sound like "Donald Duck". Tuning of SSB signals takes a little patience and practice.

If you tune through AM signals while using the USB or LSB mode, you will have a very annoying background tone, which varies with the setting of the Tuning controls. If this happens, set **Mode** to AM.

As you have noticed, there are two Modes for SSB signals – LSB and USB (Lower Side Band and Upper Side Band).

The following chart shows you the normal SSB mode of operation for the Ham bands:

| METERS | FREQUENCY         | SIDEBAND USED |
|--------|-------------------|---------------|
| 80     | 3.5 to 4.0 MHz    | Lower         |
| 40     | 7.0 to 7.3 MHz    | Lower         |
| 20     | 14.0 to 14.35 MHz | Upper         |
| 15     | 21.0 to 21.45 MHz | Upper         |
| 10     | 28.0 to 29.7 MHz  | Upper         |

When receiving SSB signals, the precise frequency is display frequency +2 kHz if you are using the LSB mode. For the USB mode, the precise frequency of the transmission is the display frequency -2 kHz.

When tuning SSB or CW signals, you should put the **SELECTIVITY** switch in the **NARROW** position. You will also find this position helpful when trying to receive AM signals through heavy interference.

The Standby mode is always incorporated in high quality communications and Ham-type Receivers. Using this mode, you leave all the main circuits "on", but disable the audio portion. Thus, you can leave the Receiver on (to maintain maximum frequency stability) and yet are not disturbed by the audio. However, don't leave in the **STANDBY** position for many hours if you are operating from batteries (or batteries will wear out).

The DX-302 also provides for rear panel muting. Ham radio operators require this ability when operating a transmitter (while transmitting, the Receiver must be disabled). Connecting the **MUTE** screw terminal to ground will disable the Receiver. This muting function can be activated by remote switching (normally available via the transmitter).

A pair of headphones is a great asset for serious SWLing. They make it much easier to hear and understand some of those weak and distant stations. We strongly suggest you consider purchasing a pair of communications headphones – 8 ohm impedance type. Your Radio Shack store has some good choices.

You can use 12 volts DC to power your Receiver. For example, if you want to mount the Receiver in a vehicle, or take it on a field trip, a source of 12 volts DC will operate it. Connect the 12 volt DC power to the connector on the rear using the connector cord provided; if you are using this in conjunction with a vehicle, **be sure you use a 12 volt NEGATIVE ground electrical system** (almost all current U.S. vehicles use negative ground systems). Be sure you connect the external power leads with the correct polarity: + to + and - to -. (When external DC power is connected, the internal batteries are automatically disconnected.)

## CHANGES IN RECEPTION

You'll soon notice that reception on the different bands covered by your DX-302 varies with the time of day and season of the year. Certain areas of the world can be better received at certain times of the day than at others. All this may seem confusing at first, but these changes in reception do follow a clear pattern which you can use in planning your listening time.

Generally speaking, the 10 kHz to 10 MHz range will give best reception from the late afternoon (approximately two hours before your local sunset) until shortly after dawn at your listening location. In the late afternoon and evening hours you'll find stations to the east of your location coming in well. But as the night wears on, these stations will fade out and be replaced by stations to the west of your location. For example, listeners in the United States will find stations in Europe and Africa best received on 49 meters (5950 ~ 6200 kHz) during the late afternoon and early evening. Later in the night, stations from the Pacific Ocean area will fade in, followed soon by stations in Asia and Australia. Stations in Latin America can be received most of the night since that area is in darkness approximately the same time as North America.

The 11 to 15 MHz range is a transition area, with signals often found here at all hours, although they may not be as strong as those on other bands.

From 15 to 30 MHz is primarily a daytime range, with often no signals audible during the night. In the morning hours and early afternoon signals will be heard from east of your location. During late afternoons and early evening listen for stations west of you.

Reception also varies with the season of the year. Signals in the 10 kHz to 10 MHz range are often stronger in the winter; while during the summer months stations can be heard in the 10 to 30 MHz range well into the night.

## BAND ALLOCATION

To avoid interference and confusion, certain portions of the radio spectrum have been set aside for specific purposes. Perhaps the most familiar example is 540 – 1600 kHz, which is the "standard" AM broadcast band.

Ham radio operators have use of the following bands:

160 meters = 1.8 – 2.0 MHz  
80 meters = 3.5 – 4.0 MHz  
40 meters = 7.0 – 7.30 MHz  
20 meters = 14 – 14.35 MHz  
15 meters = 21 – 21.45 MHz  
10 meters = 28 – 29.7 MHz

International broadcasting stations have several bands set aside for them:

49 meters = 5.95 – 6.2 MHz  
41 meters = 7.1 – 7.3 MHz  
31 meters = 9.5 – 9.775 MHz  
25 meters = 11.7 – 11.975 MHz  
19 meters = 15.1 – 15.45 MHz  
16 meters = 17.7 – 17.9 MHz  
13 meters = 21.45 – 21.75 MHz  
11 meters = 25.6 – 26.1 MHz

Note that broadcasters and hams share 7.1 – 7.3 MHz, and interference is heavy in that range.

Broadcasters in tropical regions have special bands set aside for them. In such areas shortwave is the only way to reach isolated locations:

120 meters = 2.3 – 2.498 MHz  
90 meters = 3.2 – 3.4 MHz  
60 meters = 4.75 – 5.06 MHz

The rest of the shortwave range is filled with marine, aeronautical and military stations. Such stations usually use either SSB or CW, and can be found outside the amateur and broadcast bands.

## FREQUENCY CONVERSION

Your Communications Receiver is calibrated in Megahertz (MHz) and Kilohertz (kHz) — as most communications-type receivers are. However there is one other term used quite often — you should know these terms and how to convert from each one to the others.

First, Megahertz. This stands for millions-of-Hertz (or cycles-per-Second as we used to call Hertz). A Megahertz is 1,000,000 Hertz (Hz for short) or 1,000,000 cycles-per-second. Mega means million.

Second, Kilohertz. This stands for thousands-of-Hertz. A Kilohertz is 1,000 Hertz. We use the abbreviation kHz; thus, 1 kHz. Kilo means thousand.

Third, Meter. The term Meter, as applied to Short Wave Listening, refers to the wavelength of a radio frequency. In many parts of the world, frequencies are listed in Meters; for example, International Short Wave Stations in the 19 Meter band. European radio equipment and stations often refer to the wavelength of a station or band (in meters), rather than the frequency (in MHz or kHz).

The relationship of these three terms is:

$$1 \text{ MHz (million)} = 1000 \text{ kHz (thousand)}$$

Thus, to change 9.62 MHz to kHz, we multiply by 1000.

$$9.62 \times 1000 = 9620 \text{ kHz}$$

To go the other way, from kHz to MHz, divide by 1000. Thus, a station at 3780 kHz is

$$\frac{3780}{1000} = 3.780 \text{ MHz}$$

To convert MHz to meters, use this formula:

$$\text{Meters} = \frac{300}{\text{MHz}}$$

Example: What is the wavelength of 7.1 MHz?

$$\frac{300}{7.1 \text{ MHz}} = 42.25 \text{ meters}$$

## TIME CONVERSION

A 24-hour clock is used to tell communications time. One AM is 0100; four AM is 0400; Noon is 1200; 3:30 PM is 1530; 8:45 PM is 2045. This simple method precludes any confusion between AM and PM. (See Chart).

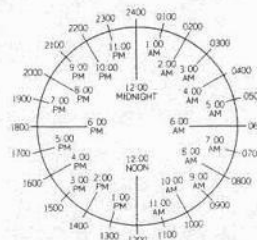

GMT (Greenwich Mean Time — the time at Greenwich Observatory, England) is the basis for telling time in International Broadcasting. To convert from GMT to local time or any other time zone, add or subtract the hours shown on the INTERNATIONAL TIME MAP (below). GMT is also termed "Z" or Zulu time. Or UTC (Coordinated Universal Time); UTC will become the standard term for this time within a few years — so get used to it.

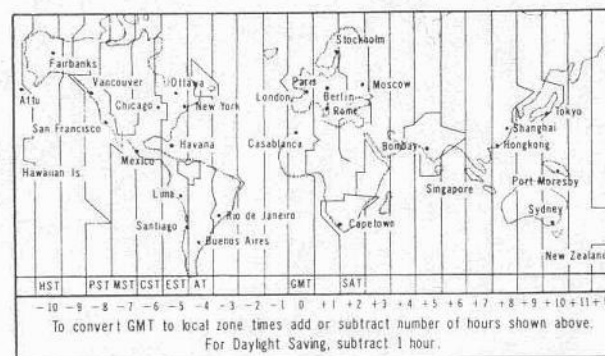

Example: 2300 GMT is 1800 EST (Eastern Standard Time). This is equivalent to 11:00 PM in London, Eng., 6:00 PM in New York or 8:00 AM in Tokyo (the next day).

## LISTENING NOTES

If you have never tuned a shortwave receiver before, you may be a bit confused by the wide variety of signals which can be heard. To help you find your way around the bands, here is a summary of what to expect.

**The 10 to 150 kHz range** is often called the very low frequency (VLF) band. Stations in this range generally fall into two classifications, experimental and military (usually Navy). Voice transmission is not used in this range, with Morse code and special transmission methods favored. The reason this range is used by the Navy is because VLF signals can easily penetrate underwater, making this range appropriate for communication with submarines. As you might expect, reception on this band will be enhanced if you are near the coast. A very long antenna (at least over 100 feet [30 m]) is also required for best reception.

**The 150 – 540 kHz range** is known as the longwave band. You'll find reception here best during the nighttime hours at your location. The majority of stations use Morse code, although you will hear AM used for weather broadcasts. The largest number of stations here are beacons for aircraft and marine navigation. Beacons transmit their call letters continuously in Morse code at a slow speed. Using the Morse code table in this manual, you can decode the call letters of most beacons. A manual on air or marine navigation, available from your public library or a marine supply store, will contain lists of these beacons and their location. Weather broadcasts on AM often identify themselves by their location instead of call letters (such as "New Orleans Radio"). A great many ship stations also use this range, with 500 kHz set aside by international agreement for distress and emergency calls.

**International Broadcast stations** can be found in the bands indicated in our section on Band Allocations. Many such stations operate in English, and can often be heard during the evening hours (between 6:00 PM and Midnight, your local time). Programming usually consists of news, commentaries, local music, and features on life in their respective countries. Among the stations which are listener favorites worldwide are Radio Japan, the British Broadcasting Company, Israel Radio, Radio Nederland in Holland and Radio Australia. You'll soon discover which stations will be your personal favorites.

In tropical areas of the world, static makes reception on the standard AM broadcasting band very difficult. This has resulted in special Tropical Bands being set aside for nations located in the tropics. Programming here is intended just for local audiences in the nation where the station is located, and much of what can be heard here is a treat — exotic languages, beautiful and unusual music, etc. Some English can be heard, however, from stations in Africa or the Pacific.

**Time standard stations** are ones you'll find quite useful. These stations give out the exact time of day at specified intervals. The National Bureau of Standards operates station WWV in Fort Collins, Colorado on 2.5, 5, 10, 15 and 20 MHz. A man's voice gives the time each minute along with periodic reports on shortwave reception conditions. The National Bureau of Standards also operates another station, WWVH, on the same frequencies as WWV, in Hawaii. WWVH uses a woman's voice to give the time. Sometimes you can hear these two stations simultaneously. Other time standard stations are Canada's CHU on 3.33, 7.335 and 14.67 MHz and VNG in Australia on 4.5 and 12 MHz. Several other nations have similar stations.

Ham radio operators can be found in the bands listed in our Band Allocations section. You'll find that hams mainly use Morse code (or CW, as they refer to it) and SSB. The ham bands are divided up into CW and SSB sections in the following manner:

3.5 – 3.8 MHz: CW  
 3.8 – 4.0 MHz: SSB  
 7.0 – 7.15 MHz: CW  
 7.15 – 7.3 MHz: SSB  
 14.0 – 14.2 MHz: CW  
 14.2 – 14.35 MHz: SSB  
 21.0 – 21.25 MHz: CW  
 21.25 – 21.45 MHz: SSB  
 28.0 – 28.5 MHz: CW  
 28.5 – 29.7 MHz: SSB

These boundaries are not precisely observed everywhere in the world, so don't be too surprised to find a SSB signal in the CW portion of a band and vice-versa.

Aircraft flying international routes use shortwave for their communications. Most transmissions are in SSB, although some AM is still heard. Some of the ranges where aircraft can be heard include:

|                     |                   |
|---------------------|-------------------|
| 4.65 – 4.75 MHz     | 11.175 – 11.4 MHz |
| 6.525 – 6.765 MHz   | 13.2 – 13.36 MHz  |
| 8.815 – 9.040 MHz   | 15.01 – 15.1 MHz  |
| 10.005 – 10.100 MHz | 17.9 – 18.03 MHz  |

Ships and coastal stations can also be heard on shortwave. Most communications are in SSB and CW. One interesting range is 2.0 – 2.3 MHz, where the Coast Guard and many small boats can be heard. One frequency to watch is 2.182 MHz, which is an international distress and emergency channel. Other bands in which to tune for ships are:

|                   |                    |
|-------------------|--------------------|
| 4.063 – 4.139 MHz | 12.33 – 12.42 MHz  |
| 4.361 – 4.438 MHz | 13.107 – 13.2 MHz  |
| 8.195 – 8.281 MHz | 16.46 – 16.565 MHz |

## RADIO TERMS

Ham radio operators and shortwave fans frequently use terms unfamiliar to most other people. Here's a brief list of some of the more common expressions:

AF GAIN Control – same as volume control  
 AM (Amplitude Modulation) – the amplitude of the transmitting signal is varied at an audio rate.  
 ANL (Automatic Noise Limiter) – reduces impulse noises (ignition, static, crashes, etc.).  
 ANT – Antenna  
 AVC (Automatic Volume Control) – controls the gain of the radio frequency amplifying circuits automatically (i.e. reduces gain on strong signals).  
 BFO (Beat Frequency Oscillator) – provides a special internal signal so that CW (code) signals can be heard.  
 CQ – a general call used by radio amateurs to establish contact. Caller will talk to anyone who answers. Can also be used specifically (CQ/DX, when calling only DX stations, or CQ Chicago, when calling stations only in Chicago).  
 CW (Continuous Wave) – another term for Morse code transmission.  
 DX – distant stations  
 FM (Frequency Modulation) – the transmitting frequency is varied at an audio rate.  
 QRM – interference from other signals.  
 QRN – static  
 QRX – Standby  
 QSL – usually a card which verifies contact or acknowledges specific transmission  
 QSO – a contact between two stations  
 QSY – change operating frequency.  
 RF Gain Control – radio frequency gain control: controls the sensitivity of the radio frequency amplifier stage.  
 RST – readability, strength, tone (refers to a system of rating the quality of reception of code signals)  
 SSB – Single Side Band (USB = upper side band; LSB = lower side band).  
 SWL – short wave listener  
 73's – best regard  
 88's – love and kisses  
 XYL – wife  
 YL – young lady

## MORSE CODE

It is possible to eavesdrop on Morse code messages even if you don't understand the code. Simply connect a tape recorder to the TAPE OUT jack of your DX-302 and record Morse messages off the air. You can then use this code table to decode the messages you have received. You may find it helpful to play back messages at a slower speed than they were recorded. Adjust BFO PITCH when receiving CW on your DX-302 for the most pleasing tone. Should you desire to learn to send and receive CW, your local Radio Shack has a code instruction cassette (20-026) and a key (20-1084), which can plug directly into the KEY jack on the rear of your DX-302. Ability to send and receive Morse code is one the requirements for a ham radio operator's license.

| Letter Phonetic Sound | Dot-Dash Sequence | Letter Phonetic Sound | Dot-Dash Sequence |
|-----------------------|-------------------|-----------------------|-------------------|
| A di-dah              | ..                | T dah                 | -                 |
| B dah-di-di-dit       | ....              | U di-di-dah           | ---               |
| C dah-di-dah-dit      | ---.              | V di-di-di-dah        | ....-             |
| D dah-di-dit          | ....              | W di-dah-dah          | ---               |
| E dit                 | .                 | X dah-di-di-dah       | ---.              |
| F di-di-dah-dit       | ....              | Y dah-di-dah-dah      | ---.              |
| G dah-dah-dit         | ---.              | Z dah-dah-di-dit      | ....              |
| H di-di-di-dit        | ....              |                       |                   |
| I di-dit              | ..                | Numbers               |                   |
| J di-dah-dah-dah      | ----              | 1 di-dah-dah-dah-dah  | -----             |
| K dah-di-dah          | ---.              | 2 di-di-dah-dah-dah   | -----             |
| L di-dah-di-dit       | ....              | 3 di-di-di-dah-dah    | -----             |
| M dah-dah             | ---               | 4 di-di-di-di-dah     | -----             |
| N dah-dit             | ..                | 5 di-di-di-di-dit     | -----             |
| O dah-dah-dah         | ---               | 6 dah-di-di-di-dit    | -----             |
| P di-dah-dah-dit      | ....              | 7 dah-dah-di-di-dit   | -----             |
| Q dah-dah-di-dah      | ---.              | 8 dah-dah-dah-di-dit  | -----             |
| R di-dah-dit          | ....              | 9 dah-dah-dah-dah-dit | -----             |
| S di-di-dit           | ....              | 0 dah-dah-dah-dah-dah | -----             |

## THE SHORTWAVE HOBBY

Shortwave listening (SWLing) is a hobby with thousands of participants worldwide. While no special knowledge is required for SWLing, you will find your enjoyment increases with experience and special techniques for listening.

Random tuning on your DX-302 is a good idea if you've never owned a Communications Receiver before. In this way you can get acquainted with the various bands and the stations which can be heard. But after you've been listening for a while you'll discover that you can get more enjoyment by organizing your listening efforts.

Your local Radio Shack has a book entitled *Shortwave Listener's Guide* (62-2032). It lists stations around the world along with their frequency, call letters, and hours of operation. You'll find a copy of this book valuable when you want to hear a specific station — it will save you hours of searching the airwaves at random to find the station you want to hear.

You will also find it valuable to keep a Log Book of what you hear. This will allow you to discover patterns of station activity (hours and days of operation, etc.) and enable you to keep track of what you've heard. Many listeners enjoy trying to hear as many different stations and countries as possible. A Log Book will also be an interesting diary of your listening experiences. Your local Radio Shack has a convenient Log Book (62-2034).

Doing a little bit of library research can increase your skill as a SWL. Read up on radio propagation and theory; try to understand the conditions which make long distance reception possible. In your local library you can find such valuable references as the *World Radio Television Handbook* and the *Radio Amateur's Handbook*. Current information can be found by consulting periodicals dealing with communications and electronics.

Keep up to date on news events around the world. There's much interesting listening just tuning to the international service of a nation where an important event is taking place.

## REPORTING AND QSLs

You'll soon notice that many of the international broadcasting stations will ask for "reception reports" from listeners and offer to send "QSL cards" in return. Since "QSLing" is a major goal of many SWLs, let's discuss what's involved.

International broadcasters like to get letters from listeners telling how well their signals are being received. To encourage listeners to write more often, stations reply to listener reception reports with cards or letters confirming that the SWL indeed heard the station. Numerous SWLs eagerly collect these confirming cards or letters, known as QSLs, and some have managed to get QSLs from stations in over 200 different countries. Major international broadcasters frequently change the designs of their QSL cards, and many SWLs like to collect entire sets of QSLs from a single station.

What goes into a good reception report? Tell the station the frequency you heard them on, the time (use GMT from our Time Conversion chart), and the date on which you received them. Include some details about the program you heard (announcer names, program titles, musical selections, etc.) so that the station will know you really heard them. Describe the strength and readability of their signals, making careful note of any interfering stations. Tell them that you use a Realistic DX-302 and also describe your antenna system. You might also want to include comments on the type of programs you want to hear in the future, as well as some remarks on the broadcast you are reporting on. Finally, request that if your report is correct that the station send you a QSL card or letter.

If the broadcast you heard was in English, you can send your report in that language as well. Usually the station will give its address during the program, but for most larger stations you can simply send your report to the station's studio location (such as Israel Radio, Jerusalem, Israel). One pleasant benefit of reporting is that many stations will put you on their mailing list to receive program schedules and special mailings of interest to listeners. Some stations even send out special gifts and souvenirs to regular reporters.

## AMATEUR RADIO

If you spend much time listening to ham radio operators on your DX-302, you may become interested in getting a ham license. Ham licenses are issued to any resident of the United States, regardless of age, upon passing the appropriate test in Morse code and electronic theory. Currently, there are five classes of ham licenses:

- Novice
- Technician
- General
- Advanced
- Extra

The Novice is the simplest, requiring the applicant to receive code at a speed of five words per minute and pass a simple technical exam. The Extra, by contrast, requires a code speed of twenty words per minute and a thorough technical exam. Privileges vary with the class of license. The Novice allows the holder to use Morse code and a maximum power of 250 watts in portions of the 80, 40, 15 and 10 meter bands, while the Extra allows full voice and code operation with 1000 watts of power on all amateur bands.

Ham licenses are issued by the Federal Communications Commission, Washington, DC, 20554. Application for a ham license is made on FCC form 610, which is available upon request from the FCC. They will also send you a list of locations where amateur exams are given. Of interest to applicants for the Novice class of license is the fact that Novice exams are given by hams who hold a General class or higher license instead of FCC examiners.

Many ham radio clubs hold classes for those who wish to obtain their licenses. Other clubs and individual hams gladly help interested persons become hams. The American Radio Relay League, 225 Main St., Newington, Connecticut, 06111 will refer you to a local club if you write them. Enclose a self-addressed stamped envelope with your request.



## COUNTRY LOG

The following listing contains some of the more frequently heard stations on shortwave. The stations listed can be heard throughout the North American Continent. All stations operate in English unless otherwise specified. Most of these stations do not broadcast continuously; refer to Radio Shack's *Shortwave Listener's Guide* (62 — 2032) for more precise operating date.

Obviously, reception will vary on the different frequencies according to the time of day and season of the year. Remember that reception from different parts of the world varies with the time of day and the frequency to which your DX-302 is tuned. Consult the section on Changes in Reception for a more detailed explanation of these variations.

Remember also that the 7.1 — 7.3 MHz range is shared by hams and international broadcasters; consequently, interference is very severe in that range.

While every effort has been made to insure the accuracy of this list, stations can and do change frequencies. Check periodicals on communications and electronics for more current information on station frequencies and schedules.

This list only contains broadcasting stations which operate on fixed frequencies with regular schedules. Ham, military, marine and aeronautical stations operate on varied frequencies with irregular schedules.

| MHz   | STATION                              | LOCATION                       | REMARKS                |
|-------|--------------------------------------|--------------------------------|------------------------|
| 3.223 | Radio SR                             | Sweziland                      |                        |
| 3.265 | Radio Mozambique                     | Maputo, Mozambique             | Programs in Portuguese |
| 3.300 | Radio Cultural                       | Guatemala City, Guatemala      | Religious Programs     |
| 3.380 | Radio Iris                           | Esmeraldas, Ecuador            | Programs in Spanish    |
| 3.385 | FR3                                  | Cayenne, French Guiana         | Programs in French     |
| 3.396 | Radio Kaduna                         | Kaduna, Nigeria                |                        |
| 4.750 | Radio Bertous                        | Bertoua, Cameroon              |                        |
| 4.755 | Imo Regional Radio                   | Imo, Nigeria                   |                        |
| 4.777 | Radio-TV Gabon                       | Libreville, Gabon              | Programs in French     |
| 4.795 | Radio Nueva America                  | La Paz, Bolivia                | Programs in Spanish    |
| 4.820 | Radio Paz y Bien                     | Ambata, Ecuador                | Programs in Spanish    |
| 4.832 | Radio Reloj                          | San Jose, Costa Rica           | Programs in Spanish    |
| 4.855 | Radio Clube do Para                  | Belem, Brazil                  | Programs in Portuguese |
| 4.890 | National Broadcasting Commission     | Port Moresby, Papua New Guinea |                        |
| 4.915 | Voice of Kenya                       | Nairobi, Kenya                 |                        |
| 4.920 | Australian Broadcasting Commission   | Brisbane, Australia            |                        |
| 4.945 | Radio Colosal                        | Neiva, Colombia                | Programs in Spanish    |
| 4.965 | Radio Santa Fe                       | Bogota, Colombia               | Programs in Spanish    |
| 4.980 | Ecos del Torbes                      | San Cristobal, Venezuela       | Programs in Spanish    |
| 4.990 | Radio Barquisimeto                   | Barquisimeto, Venezuela        | Programs in Spanish    |
| 5.020 | Solomon Islands Broadcasting Service | Honiara, Solomon Islands       |                        |
| 5.057 | Radio Gjirokaster                    | Gjirokaster, Albania           | Programs in Albanian   |
| 5.950 | Guyana Broadcasting Service          | Georgetown, Guyana             |                        |
| 5.954 | Radio Casino                         | Puerto Limon, Costa Rica       |                        |
| 5.960 | Radio Canada International           | Montreal, Canada               |                        |
| 5.980 | Radio RSA                            | Johannesburg, South Africa     |                        |
| 6.005 | CFCX                                 | Montreal, Canada               |                        |
| 6.025 | Radio Malaysia                       | Kuala Lumpur, Malaysia         | Programs in Chinese    |

|        |                                      |                            |                      |        |                                    |                            |                     |
|--------|--------------------------------------|----------------------------|----------------------|--------|------------------------------------|----------------------------|---------------------|
| 6.045  | Radio Australia                      | Lyndhurst, Australia       |                      | 11.835 | 4VEH                               | Cap Haitien, Haiti         |                     |
| 6.055  | Nihon Shortwave Broadcasting Company | Tokyo, Japan               | Programs in Japanese | 11.845 | Radio Canada International         | Montreal, Canada           |                     |
| 6.060  | Radio Nacional                       | Buenos Aires, Argentina    | Programs in Spanish  | 11.850 | Deutsche Welle                     | Cologne, West Germany      |                     |
| 6.075  | Radio Sutatenza                      | Bogota, Colombia           | Programs in Spanish  | 11.890 | Voice of Chile                     | Santiago, Chile            |                     |
| 6.090  | Radio Luxembourg                     | Villa Louvigny, Luxembourg |                      | 11.900 | Radio RSA                          | Johannesburg, South Africa |                     |
| 6.095  | Polskie Radio                        | Warsaw, Poland             |                      | 11.910 | BBC                                | London, England            |                     |
| 6.105  | Radio New Zealand                    | Wellington, New Zealand    |                      | 11.930 | Radio Havana Cuba                  | Havana, Cuba               |                     |
| 7.140  | Trans World Radio                    | Monte Carlo, Monaco        |                      | 11.935 | Radio Portugal                     | Lisbon, Portugal           |                     |
| 7.170  | Radio Noumea                         | Noumea, New Caledonia      | Programs in French   | 11.945 | Radio Peking                       | Peking, China              |                     |
| 7.300  | Radio Tirana                         | Tirana, Albania            |                      | 11.955 | Voice of Turkey                    | Ankara, Turkey             |                     |
| 9.475  | Radio Cairo                          | Cairo, Egypt               |                      | 11.980 | Radio Moscow                       | Moscow, USSR               |                     |
| 9.515  | Voice of Greece                      | Athens, Greece             |                      | 15.038 | Saudi Arabian Broadcasting Service | Riyadh, Saudi Arabia       | Programs in Arabic  |
| 9.525  | Radio Korea                          | Seoul, South Korea         |                      | 15.084 | Voice of Iran                      | Tehran, Iran               | Programs in Farsi   |
| 9.530  | Spanish Foreign Radio                | Madrid, Spain              |                      | 15.135 | Radio Moscow                       | Moscow, USSR               |                     |
| 9.535  | Swiss Radio International            | Berne, Switzerland         |                      | 15.165 | HCJB                               | Quito, Ecuador             |                     |
| 9.540  | Radio Prague                         | Prague, Czechoslovakia     |                      | 15.190 | ORU                                | Brussels, Belgium          |                     |
| 9.570  | Radio Bucharest                      | Bucharest, Rumania         |                      | 15.205 | All India Radio                    | New Delhi, India           |                     |
| 9.575  | Italian Radio and Television Service | Rome, Italy                |                      | 15.260 | BBC                                | London, England            |                     |
| 9.610  | Radio-TV Algeria                     | Algiers, Algeria           | Programs in Arabic   | 15.265 | Finnish Radio                      | Helsinki, Finland          |                     |
| 9.620  | Radio Berlin International           | Berlin, East Germany       |                      | 15.275 | Radio Sweden                       | Stockholm, Sweden          |                     |
| 9.645  | Radio Norway                         | Oslo, Norway               |                      | 15.305 | Swiss Radio International          | Berne, Switzerland         |                     |
| 9.720  | Radio Iran                           | Tehran, Iran               | Programs in Farsi    | 15.310 | Radio Japan                        | Tokyo, Japan               |                     |
| 9.745  | HCJB                                 | Quito, Ecuador             |                      | 15.320 | Radio Australia                    | Melbourne, Australia       |                     |
| 9.770  | Austrian Radio                       | Vienna, Austria            |                      | 15.400 | BBC                                | London, England            |                     |
| 9.800  | Radio Kiev                           | Kiev, USSR                 |                      | 15.430 | Radio Mexico                       | Mexico City, Mexico        | Programs in Spanish |
| 9.835  | Radio Budapest                       | Budapest, Hungary          |                      | 15.465 | Radio Pakistan                     | Islamabad, Pakistan        | Programs in Urdu    |
| 10.040 | Voice of Vietnam                     | Hanoi, Vietnam             |                      | 17.720 | Radio France International         | Paris, France              |                     |
| 11.655 | Israel Radio                         | Jerusalem, Israel          |                      | 17.825 | Vatican Radio                      | Vatican City               |                     |
| 11.690 | Radio Kuwait                         | Kuwait, Kuwait             |                      | 17.860 | Austrian Radio                     | Vienna, Austria            |                     |
| 11.705 | Radio Sweden                         | Stockholm, Sweden          |                      | 21.495 | Israel Radio                       | Jerusalem, Israel          |                     |
| 11.720 | Radio Moscow                         | Moscow, USSR               |                      | 21.525 | Radio Australia                    | Melbourne, Australia       |                     |
| 11.735 | Radio Sofia                          | Sofia, Bulgaria            |                      | 21.625 | Israel Radio                       | Jerusalem, Israel          |                     |
| 11.745 | Voice of Free China                  | Taipei, Taiwan             |                      | 21.645 | Radio France International         | Paris, France              |                     |
| 11.815 | Radio Japan                          | Tokyo, Japan               |                      | 21.735 | Radio-TV Morocco                   | Rabat, Morocco             | Programs in Arabic  |
| 11.825 | Radio Tahiti                         | Papeete, Tahiti            | Programs in Tahitian | 25.650 | BBC                                | London, England            |                     |
|        |                                      |                            |                      | 25.790 | Radio RSA                          | Johannesburg, South Africa |                     |

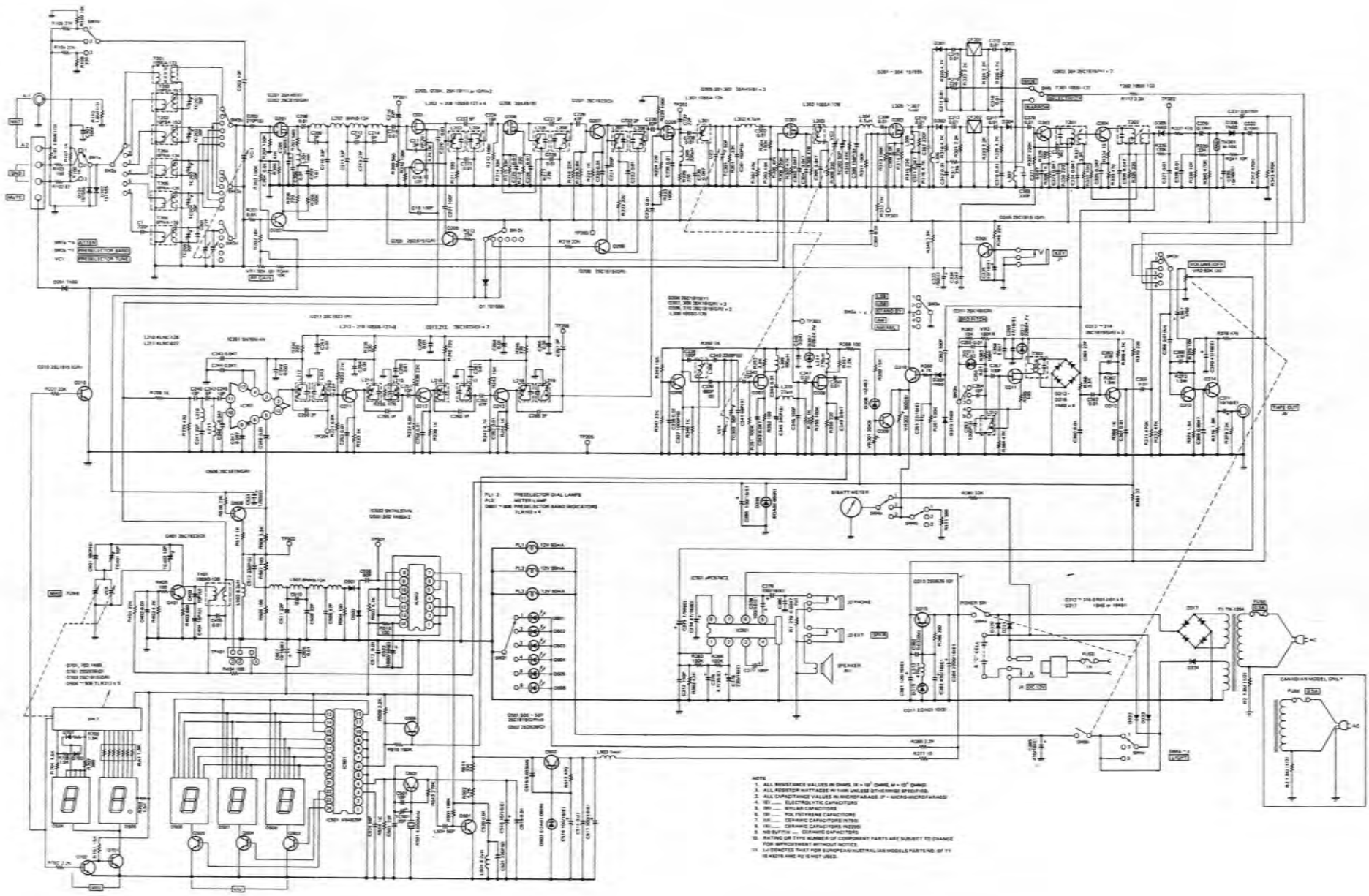

- NOTE
1. ALL RESISTOR VALUES IN OHMS, K = 10<sup>3</sup> OHMS, M = 10<sup>6</sup> OHMS
  2. ALL RESISTOR WATTAGES IN THIS UNLESS OTHERWISE SPECIFIED
  3. ALL CAPACITOR VALUES IN MICRO FARADS IF MICRO-FARAD PAKAGE
  4. (E) — ELECTROLYTIC CAPACITORS
  5. (M) — METAL CAPACITORS
  6. (P) — POLYESTER CAPACITORS
  7. (N) — CERAMIC CAPACITORS IN THIS
  8. (M) — CERAMIC CAPACITORS IN THIS
  9. (M) — CERAMIC CAPACITORS IN THIS
  10. (M) — CERAMIC CAPACITORS IN THIS
  11. (M) — CERAMIC CAPACITORS IN THIS
  12. (M) — CERAMIC CAPACITORS IN THIS
  13. (M) — CERAMIC CAPACITORS IN THIS
  14. (M) — CERAMIC CAPACITORS IN THIS
  15. (M) — CERAMIC CAPACITORS IN THIS
  16. (M) — CERAMIC CAPACITORS IN THIS
  17. (M) — CERAMIC CAPACITORS IN THIS
  18. (M) — CERAMIC CAPACITORS IN THIS
  19. (M) — CERAMIC CAPACITORS IN THIS
  20. (M) — CERAMIC CAPACITORS IN THIS

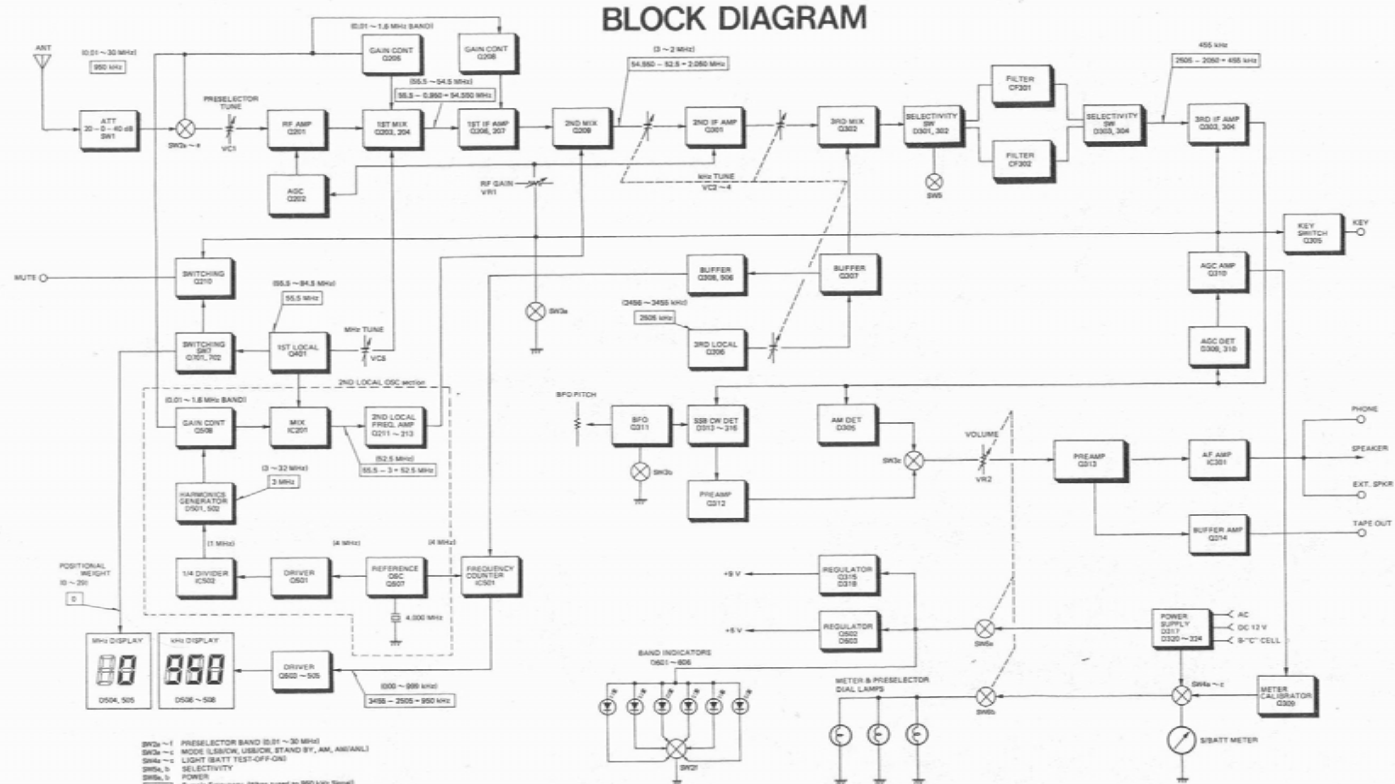

**RADIO SHACK A DIVISION OF TANDY CORPORATION**

**U.S.A.: FORT WORTH, TEXAS 76102**  
**CANADA: BARRIE, ONTARIO L4M 4W5**

---

**TANDY CORPORATION**

| AUSTRALIA                                       | BELGIUM                                    | U. K.  |
|---|--|--|
| 280-316 VICTORIA ROAD<br>RYDALMERE, N.S.W. 2116 | PARC INDUSTRIEL DE NANINNE<br>5140 NANINNE | BILSTON ROAD<br>WEDNESBURY, WEST MIDLANDS WS10 7JN |