

# Instruction Manual

## *The “Small Wonder - 80+”* 80 Meter Superhet Transceiver Kit

**Thanks!** For purchasing one of the Small Wonder Labs “SW-80+” transceiver kits. This kit is an updated version of the classic ‘40-40’ transceiver board which originally appeared in the November 1994 issue of QST.

Please take a few moments to look over the section entitled “First Things First”. This is background information in case you’re fairly new to homebrewing or kit-building.

***Please*** – Be sure to read through the “**Building Instructions**” portion of this manual before you fire that soldering iron up! That section contains useful information which is important to your success with this kit.

### TABLE OF CONTENTS

First Things First .....	2
Materials.....	4
Parts List.....	4-5
Theory of Operation .....	6
Schematic .....	7
Pictorial Drawing .....	8
Building Instructions.....	9-11
Wiring the “SW-80+”.....	12
Alignment.....	14
Troubleshooting the “SW-80+” .....	15
Troubleshooting Values .....	17

▪ THE FINE PRINT

There are lots of small parts in this kit. With many of us getting older, this may prove troublesome. I highly recommend a magnifying glass or close-up glasses to check all solder joints and component codes.

▪ THE OTHER FINE PRINT

Despite the care I've put into this manual, it may contain the occasional error. In the event of a conflict between portions of this manual, the following order of precedence applies (most trustworthy first):

- Schematic
- Pictorial
- Parts list
- Everything else

By all means, let me know when you catch these – I do appreciate hearing about them. I add corrective changes immediately because it improves the product!

## TOOLS

You'll need the following tools:

- Soldering iron – 25-40W, solder
- Diagonal cutters
- Needle-nose pliers (helpful)
- Small slot screwdriver
- Magnifying glass (recommended)

## TEST EQUIPMENT

You'll need the following:

- DC power source – 12-14V @ 500mA min.
- Multimeter
- Another transceiver (for final adjustment)
- Frequency counter (helpful but not essential)

## First Things First

- what you should know -

You don't need to be an expert in all phases of this craft, but you should be comfortable with the basics before you embark on this adventure.

- You should be familiar with the standard color-code markings on resistors. If not, Radio Shack's Color-Code Guide, #271-1210, will help. If you're not sure, verify the resistor values with an ohm meter. Resistor color codes are given in the parts list.
- For what it's worth, approximately 8% of the male population is red/green colorblind. If you're one of these, you should be verifying all resistors with a meter before installing them.
- The SW-80+ board is double-sided, and all holes on the board are plated-through. This means that you **do not** need to solder on the top side of the board.

### Soldering skills:

Hopefully this isn't your first experience with a soldering iron. If it is, though, or this is your first solid-state project, here are some tips to ensure your success:

- Use a small iron in the 25-watt class (such as a Radio Shack #64-2070) and keep the tip clean. Use a moistened sponge or paper towel and clean the tip periodically as you work.
- Apply only as much heat as is needed to get a good joint. A small vise to hold the printed-circuit board may make soldering easier.
- Touch the soldering iron tip to the PC board trace and the component lead simultaneously. Within a second or two, apply solder and you'll see the solder flow onto the junction. Withdraw the solder and then the soldering iron.
- Avoid the temptation to load solder onto the joint until no more will fit! This is an invitation for trouble, as solder bridges may form across the closer trace separations. Here's what the correct and incorrect joint treatments look like:

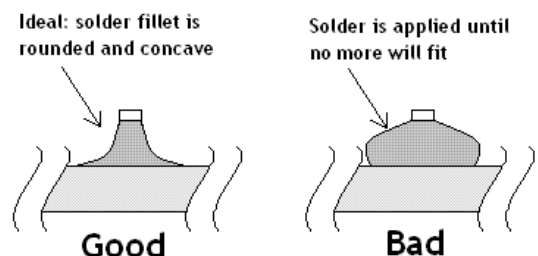

PLEASE READ THE SECTION BELOW BEFORE REMOVING ANY PARTS FROM THE CIRCUIT BOARD

Get yourself a roll of desoldering braid (Radio Shack #64-2090B). Lay the end of the braid down on the joint to be cleaned and press the soldering iron tip over the braid. Within several seconds you'll see the braid begin to wick up solder from the joint. Remove the braid and reapply a new section as needed until the joint is clean. It may be necessary to pull the component out from the top side of the board while heating the joint. Leave the iron tip on the board only as long as necessary to do the job – the PC board traces will eventually delaminate (peel off) if overheated.

If that still doesn't do the trick, it may be necessary to cut the offending part off on the top side and pull the remaining leads through with pliers. Contact me for replacement parts if necessary.

- If you need to remove a transistor I'd highly recommend sacrificing the part by snipping it off on the top side of the board. The TO-92 pads in particular are small and the leads are best pulled out independently to minimize the risk of lifting pads.
- After removing a component from the board, the through-hole will probably still be blocked with solder. Use a dissecting needle, dental probe (explorer), or even a large sewing needle, applying heat to the needle and board trace simultaneously until the tool pushes through.

*Winding Toroids:*

- Count as you go. Draw each turn snug against the core to ensure a trim and tight winding. Please ensure that none of the turns is wound "over" (on top of) its neighbors.
- Double-check the turn count when you're finished. Use your fingernail or a small screwdriver to "bump" over each turn as you count – this is much easier than counting by eye.
- Trim the excess wire off to about ¼" and strip the insulation off with a hobby knife.

*Counting the turns*

- If the wire passes through the toroid center hole, it counts as a turn.

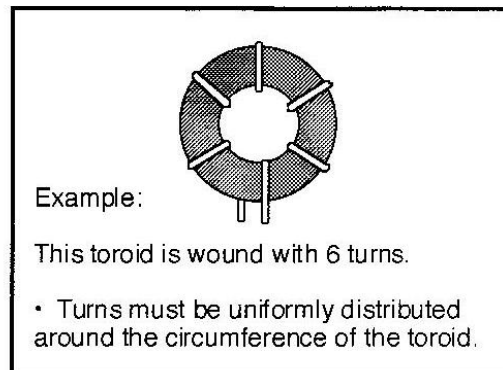

## Materials

You'll find the following items included with your SW-80+ kit:

- 1 bag of small parts (resistors, caps, etc.)
- 1 antistatic bag (semiconductors)
- 1 bag, miscellaneous parts
- 1 printed circuit board
- This manual

**Note:** The RF chokes for this kit are supplied in the 'miscellaneous' bag' to keep them separate from similar-looking resistors.

(You may want to reproduce the schematic and pictorial pages so you can mark them as you work, and still keep the originals clean.)

## Special Parts Notes

### • Capacitors:

Here's a general rule for capacitor markings:

If 3 digits are printed on the capacitor, the first two are significant figures and the third is a multiplier.

Examples:

'471' =  $47 \times 10^1 = 470$  pF

'103' =  $10 \times 10^3 = 10,000$  pF = .01 uF

Letter suffixes: J=5%, K=10%, M=20%.

### Reference designators:

Each component is uniquely identified by a reference designator. Bypass capacitors are identified as C100 and up.

### "C7":

- Capacitor C7 is an assortment of 6 different capacitors designated 'C7A' through 'C7F'. Selection and installation of this capacitor is described later in the text.

### Monolithic capacitors:

- The printing on these parts is tiny! I'd highly recommend using a magnifying glass to verify component values before installing them.

### IF Transformers:

- Although not illustrated on the schematic drawing for reasons of drawing clarity, T1-T3 contain internal capacitors. Do not remove these capacitors.

### RF Chokes:

The order of the color-bands on the RF chokes may vary by manufacturer.

---

## Parts List - SW-80+ Transceiver

Qty	Ref. Desig.	Description	Identification
3	C3,C7A,C9	10 pF ceramic disk	'10'
2	C7B, C11	22 pF NPO cer. disk	'22'
1	C7C	33 pF NPO cer. disk	'33'
2	C2, C7D	47 pF NPO cer. disk	'47'
4	C7E,C8,C17,C28	68 pF NPO cer. disk	'68'
2	C7F,C40A	82pF NPO cer. disk	'82'
2	C7G,C40B	100 pF NPO mono. cap	epoxy, '101J'
1	C7H	120 pF NPO mono. cap	epoxy, '121J'
3	C18, C22, C23	150 pF cer. disk	'151J'
1	C29	220 pF cer. disk	'221J'
5	C10, 12-15	270 pF cer. Disk	'271'
3	C1, C30,C32	330 pF cer. Disk	'331'
1	C31	470 pF cer. disk	'471'

## *Parts List (continued)*

1	C25	820 pF mylar cap	'821'
2	C26,C38	.0022 uF NPO mono. cap	'222'
3	C4-6	2700 pF NPO mono. cap	epoxy, '272'
11	C21, 33-35, 102-105, 108, 109, 111	.01 uF ceramic disk	'103M'
1	C19	.033 uF disk or mono. cap	'333'
7	C20, 24, 36, 101, 107, 113, 114	0.1 uF mono. cap	epoxy, '104'
1	C110	3.3 uF 50V radial elec. cap	<i>band on case is negative</i>
2	C27, 106	47 uF 16V or 25V radial elec. cap	<i>band on case is negative</i>
1	C112	220 uF 16V or 25V radial elec. cap	<i>band on case is negative</i>
1	D1	MV1662 varicap diode	TO-92, 2 leads, stripes only
9	D2-10	1N4148A diode	glass body
1	D11	7.5V 0.5W 5% zener diode	1N5236, <i>in Misc. envelope</i>
1	D12	30V 0.5W 5% zener diode	1N5256, <i>in Misc. envelope</i>
1	D13	1N4001 diode	Black case
1	L1	T-37-6, <i>see text, p. 10</i>	0.37" dia., yellow
1	L2	FT37-43, 10 turns #24	0.37" dia., dark grey
2	L3, 4	T-37-2, 1.9 uH, 22 turns #26	0.37" dia., red
1	Q1	2N5485 or 2N5486	plastic-cased (TO-92)
1	Q3	2N3906	plastic-cased (TO-92)
3	Q2, 4, 5	2N4401	plastic-cased (TO-92)
1	Q6	2SC2166	RF power transistor
1	RFC1	10 uH RF choke	Brn-Blk-Blk
2	RFC2	6.8 uH RF choke	Blue-Grey-Gold
1	RFC3	22 uH RF choke	Red-Red-Gold
1	R24	500Ω trim pot	Blue plastic, 3 leads
3	R6, 14, 27	10Ω 1/4W 5% resistor	Brn-Blk-Blk-Gold
2	R28, 29	51Ω 1/4W 5% resistor	Grn-Brn-Blk-Gold
1	R1	330Ω 1/4W 5% resistor	Orange-Orange-Brn-Gold
1	R26	470Ω 1/4W 5% resistor	Yellow-Viol-Brn-Gold
1	R19	1KΩ 1/4W 5% resistor	Brn-Blk-Red-Gold
2	R17, 25	2.2KΩ 1/4W 5% resistor	Red-Red-Red-Gold
4	R2, 3, 21, 22	10KΩ 1/4W 5% resistor	Brn-Blk-Orange-Gold
4	R10, 16, 20, 23	22KΩ 1/4W 5% resistor	Red-Red-Orange-Gold
1	R15	47KΩ 1/4W 5% resistor	Yellow-Viol-Orange-Gold
3	R4, 7, 11	510KΩ 1/4W 5% resistor	Grn-Brn-Yellow-Gold
4	R8, 12, 13, 18	1MΩ 1/4W 5% resistor	Brn-Blk-Grn-Gold
1	R9	4.7MΩ 1/4W 5% resistor	Yellow-Viol-Grn-Gold
4	S1-4	8-pin low-profile IC socket	
3	T1-3	10.7 MHz IF transformer	'42IF123'
1	T4	FT37-43, 8T:1T, <i>see text</i>	0.37" dia., dark grey
1	U2	78L08 voltage regulator	plastic-cased (TO-92)
3	U1, 3, 5	SA602AN or SA612AN	8-pin IC
1	U4	NE5532	8-pin IC
1	W1	jumper, install at 'C16'	<i>Make from resistor lead</i>
5	Y1-5	8.00 MHz HC-49U Xtal, 20pF	<i>(may be house # marked)</i>

## Theory of operation

This transceiver is a single PC-board design measuring 2.8" x 4.0" (7 x 10 cm). It features VFO operation with a 35- kHz tuning range, as well as QSK (full break-in) operation. Let's take the 50-cent tour:

The receiver's RF input is applied to U1 through T1 and C1, which provide a bandpass filter tuned to 3.5 MHz. T1's secondary winding provides roughly unity gain into U1 to minimize overload (IMD). U1 provides about 13dB of gain in this configuration, and converts the RF input to the IF frequency of 8.0 MHz. The L-network (C11 and RFC1) following the mixer serve to step the mixer output impedance down to the crystal filter's design value. *Note that C12 and RFC1 appear to be 'transposed'; this reflects the board's physical layout.*

The crystal filter itself uses 3 crystals. Loss through the filter is less than 2 dB, and with the component values as shown, the -6 dB bandwidth is about 800 Hz. Despite the filter's low parts count, performance is adequate when combined with the AF section's selectivity. The unwanted sideband image is down about 40 dB at the audio chain's 800 Hz peak response frequency.

The filter output is terminated in a 330Ω resistor at the input to U3, the product detector stage. U3 converts the 8.00 MHz IF signal to audio and contributes another 13 dB of gain. BFO crystal Y4 has been selected to match the IF filter frequency, so there's no BFO frequency trimming needed. The .033uF capacitor across pins 4 and 5 of U3 provides the first measure of audio low-pass filtering.

The two sections of U4 each provide roughly 30 dB of amplification. The first section is configured as a differential amplifier to make use of U3's differential output and rolls off the audio response above 1.5 KHz. Diodes D3 and D4 serve to limit the audio swing during transmitter key-down to reasonable values. Without these diodes, this stage saturates and upsets the operation of the following FET switch section.

The AF mute function is the familiar series FET switch popularized by W7EL. Despite its relative simplicity, it's hard to beat this circuit for click-free audio switching. In the "key-up" condition the FET is zero-biased and acts like a resistance of several hundred ohms. In the "key-down" condition the FET is in cutoff (because the gate is now 7-8 volts below the source) and acts like an open circuit, preventing audio from getting to U4B, the audio final stage. This stage is configured as a bandpass filter centered at 800 Hz. The high gain of the two AF

amplifier stages (64 dB total) allows a design with no IF amp stage. The audio output level is adequate to drive headphones, but it won't do the job for loudspeaker applications. The AF output stage internally overcurrent-limits on loud signals to provide a ready-made ear protection function. If you're interested in saving at least 5 milliamps on receive, U4 may be replaced by an LMC662 (available from Digikey). This suggestion is courtesy of Mitch Lee and Dennis Monticelli, from their excellent article, "Revisiting the 40-40" in the ARRL's 'QRP Power'. *Use good quality low-impedance headphones for best results. "Walkman" headphones are fine, but remember – you get what you pay for. The 3-dollar bargains are distinctly inferior!*

*QSK:* The T-R switch function is provided by C40 and RFC3, which form a series-resonant circuit. Diodes D7-D10 limit during key-down and thereby restrict the signal levels presented to the receiver front-end during transmit. *The double-diode configuration raises the network's intercept point with respect to W7EL's original configuration to improve IMD immunity.*

The Colpitts Local Oscillator (LO) runs at approximately 4.5 MHz and the operating frequency is the difference between the IF and LO frequencies. The frequency-determining capacitors are NPO (C0G) monolithic types. These devices are extremely compact and offer good temperature stability. C2 and C3 are a voltage divider providing proper injection to U1. *Note: If you want broader frequency coverage, the value of C8 may be increased. The useful upper limit for C8 is about 1000pF, and especially at the larger values, capacitor (and varicap diode D1) thermal stability will become crucial. Use NPO/C0G capacitors if possible, if you tinker with this circuit.*

The design also uses a varicap tuning diode for tuning coverage. While a smooth ball-bearing tuning cap and vernier reduction drive are the preferred approach, that choice drives the cost and mechanical complexity of a transceiver up considerably. The varicap approach supports quite a compact package! If you've just got to have RIT, an outboard circuit that injects an adjustable DC offset into the diode bias network on receive does the trick.

The transmitter chain is a pretty standard affair. The maximum output power is about 2-2.5 watts, and there's a drive control at the emitter follower stage (Q4) to adjust the output level. The diode at the base of Q6 serves to 'clamp' the signal to Q6 above ground and thus improves drive to the PA by several dB. *I don't feel that the PA requires a heat sink at the 1.5-2.5W power level and CW duty cycles. If you like, there's room for a 'compact'-style TO-220 heat sink (Digikey #HS-105 or #HS-106).*

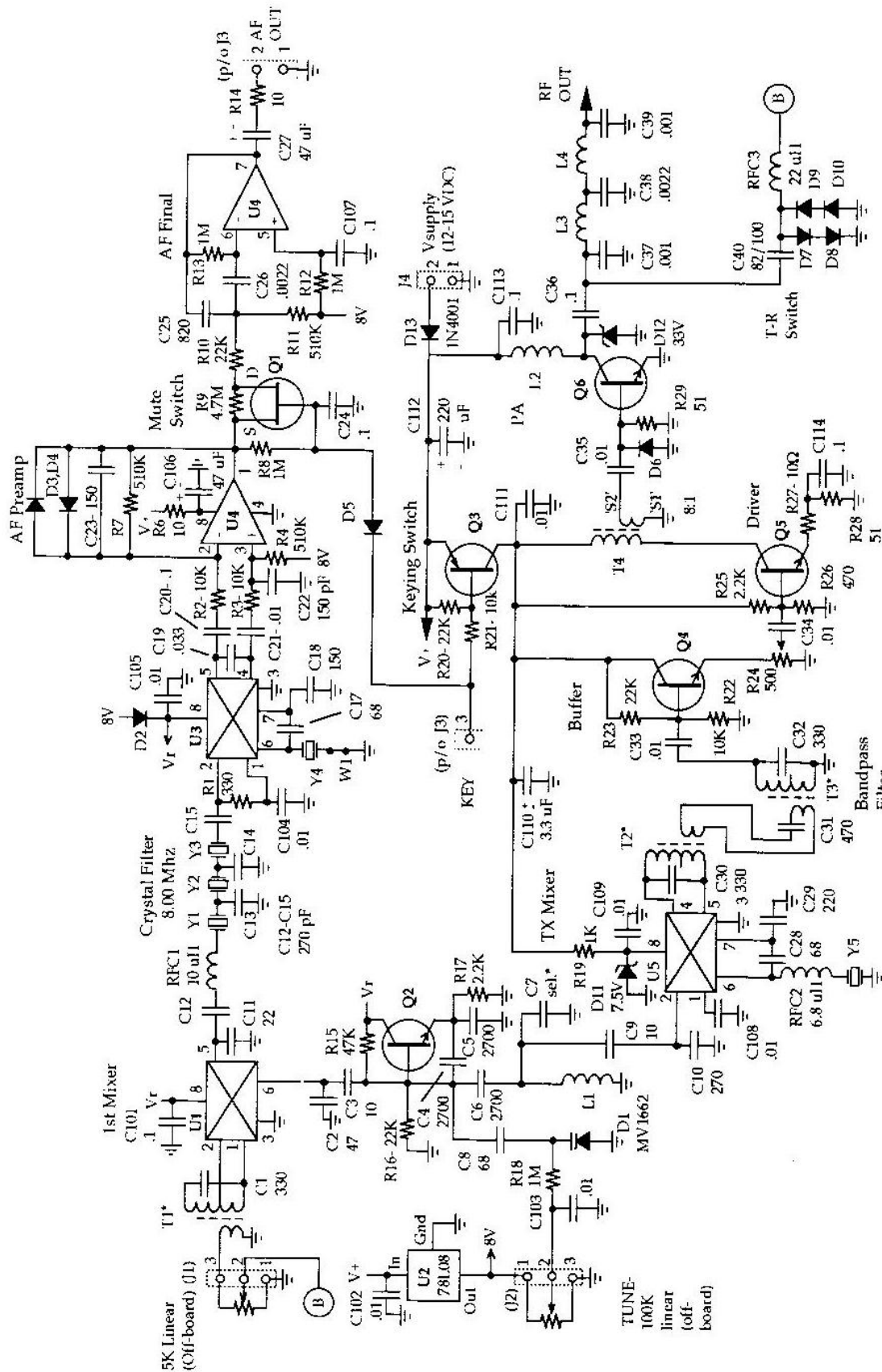

### The SW-80+ Transceiver

SMALL WONDER LABS™  
5/6/98

\* T1-T3  
C-internal not shown,  
leave intact.

[ IMAGE SCANNED FROM ORIGINAL DOCUMENT ]

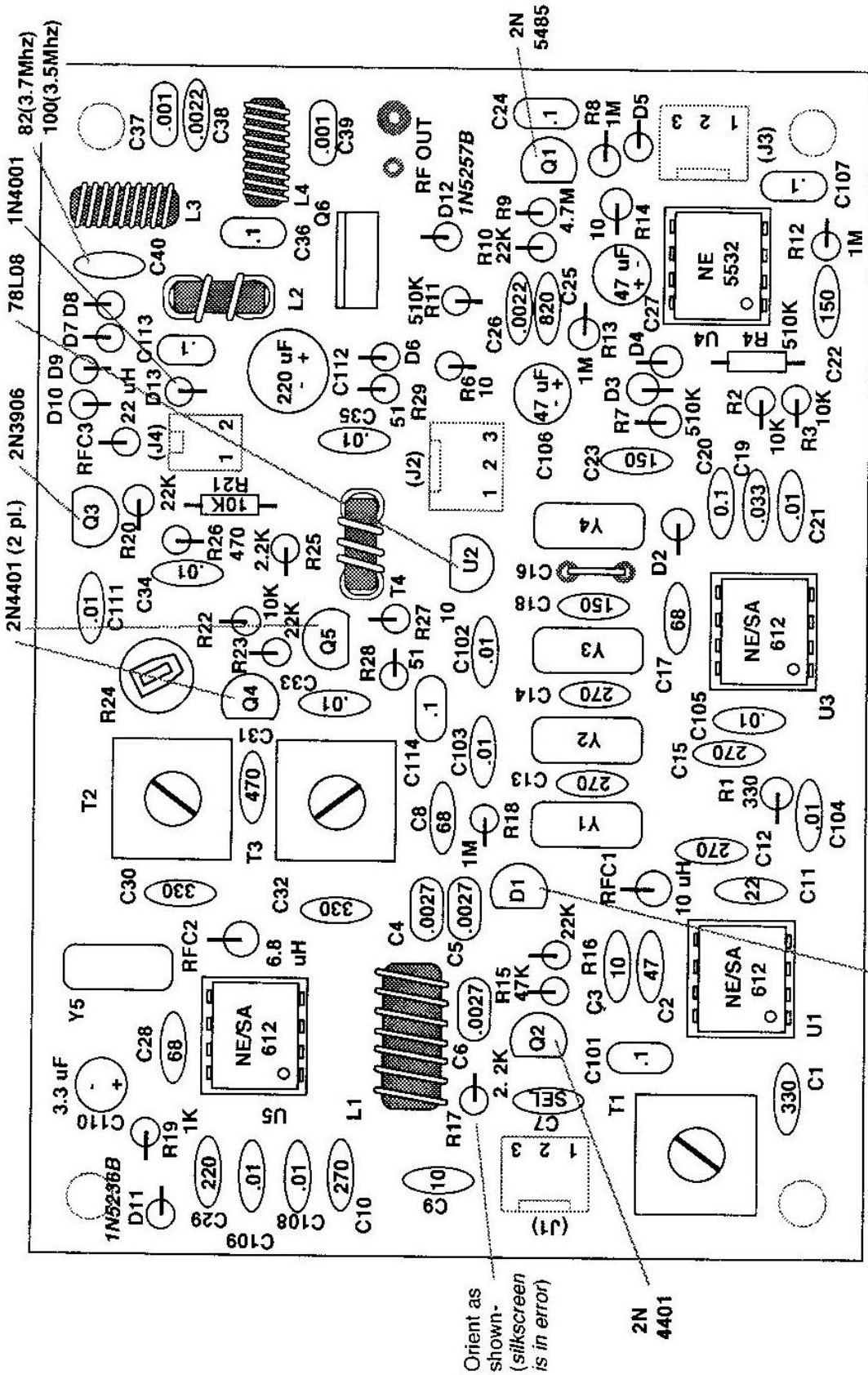

[ SCANNED FROM ORIGINAL DOCUMENT ]



## ***Building instructions***

All parts installed on the PC board should be fully seated. Do not install the parts in “flying-lead” fashion in the hope that it will improve something-or-other! Minimum lead length is important to a successful RF design.

### *Diode installation:*

All diodes except D1 are bent for “upright” installation. Installation polarity is as shown below. Be sure to note the orientation of the silk-screened circle on the board and install the diode body over this hole. The cathode (banded) end of the diode is oriented at the top.

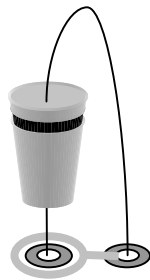

### *Resistor installation:*

All resistors except R4 and R21 are likewise mounted in “hairpin” fashion. As with the diodes, try to match the mounting orientation shown on the drawing. (This usually has nothing to do with critical dimensions – if mounted as shown you’ve got better troubleshooting access to circuit points from the top side of the board.) Orientation of resistor (and other non-polar devices) color bands is non-critical.

### *Installing IC sockets:*

The “notch” or dot at one end should be oriented as shown in the pictorial drawings. *Double-check orientation before soldering. A suggestion: solder down two opposite corners of each socket, and then go back and press a fingertip on the socket from underneath while reheating both connections in turn. You may then solder the remaining pads. This precaution ensures that the socket is well seated on the PC board.*

### *Some additional tips:*

- *It’s helpful to work from one end or corner of the board to the other. This minimizes the “tight squeeze” cases where the last part in a cluster has to drop into a tight space.*

- *Stuff only a few parts at a time (3-4 pieces). If you try to add too many parts at once between soldering operations, you may lose track and wind up with missing solder joints! Once you’ve stuffed the parts on the board, bend the protruding leads slightly outward to keep them in place while the board is inverted for soldering.*
- *Some of the disk and monolithic capacitors may be supplied with a lead spacing of 0.10” (2.5mm). The “SW-80+” has generally been laid out for a 0.20” (5mm) capacitor spacing. The capacitor leads may be gently spread apart near the component bodies and then bent parallel to ease installation.*

### ***Recommended Assembly sequence:***

I’ve specified the sequence below, but there’s nothing critical about the order in which the board is populated. Some parts are best installed in a particular order, as noted within each group’s instructions.

- Directions for winding toroids are found within each group’s assembly instructions.

(The figures which follow are for reference only. **See the pictorial drawing on p. 8 for component values.**)

[ ] Install D13, U2, C102, and C113. If you have the companion enclosure kit, install connectors J4 (2-pin) and J2 (3-pin) as well. This step supplies DC power to the board and installs the 8 Volt regulator IC.

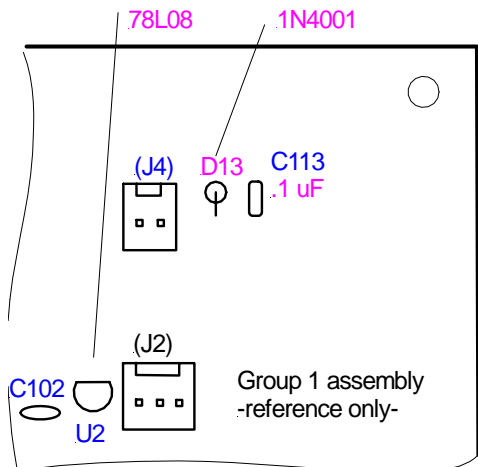

- [ ] Install an 8-pin IC socket at U4.
- [ ] Install the components shown below:

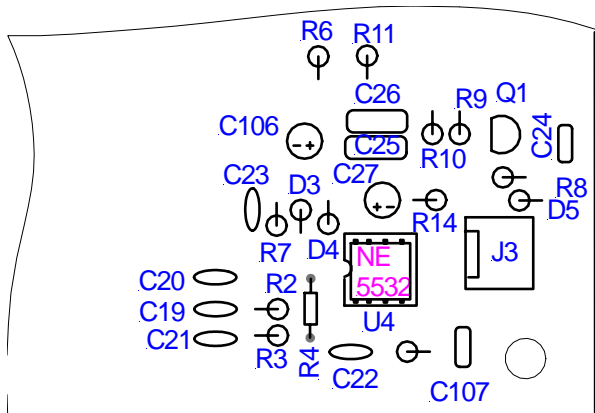

(When these components have been installed, the audio amplifier section of the transceiver is complete.)

- [ ] Install an 8-pin IC socket at U3.
- [ ] Install the components shown below:

Note: the 5 crystals supplied with this kit have been pre-selected as a group. They are interchangeable within this group. Do not, however, substitute replacement parts – contact me for assistance.

Note that the pads identified as ‘C16’ should be jumpered with a short length of wire (‘W1’). This jumper should be made from a scrap of component lead.

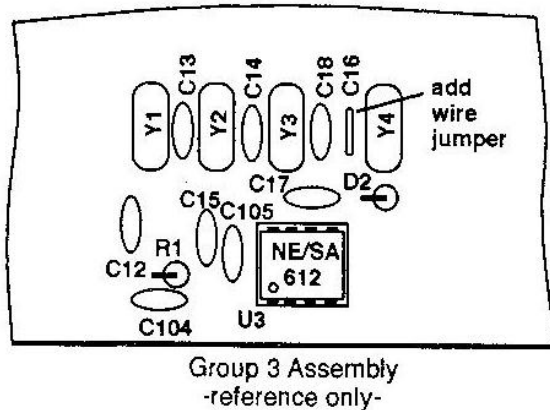

(When these components have been installed, the product detector/BFO and crystal filter sections of the transceiver are complete.)

- [ ] Install an 8-pin IC socket at U1.

Install the components shown below:

- L1 (yellow core) is wound using (18"/45cm) of the larger-diameter (#24) magnet wire. **Wind with 20 turns (21 turns for Novice-band operation.)** Prepare lead ends and install on the board.
- C7 is not installed at this time; see “Alignment” for installation procedure.

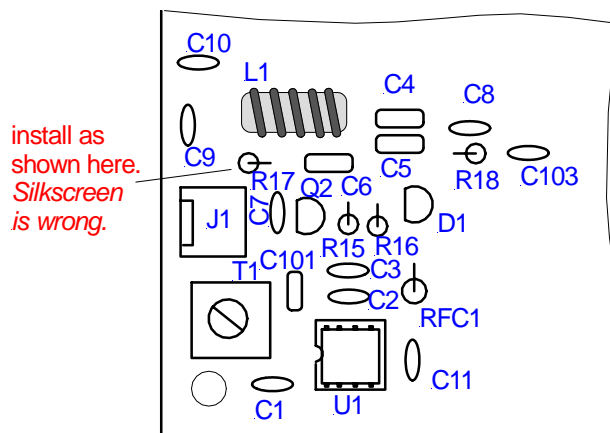

(When these components have been installed, the receiver portion of the transceiver is complete.)

[ ] Install an 8-pin IC socket at U5.

[ ] Install the components shown below:

The following components are polarity-sensitive:

D11, C110, Q3-Q5

Spacing on C31 (between transformers T2 and T3) is quite tight – install this capacitor prior to installing T2 and T3.

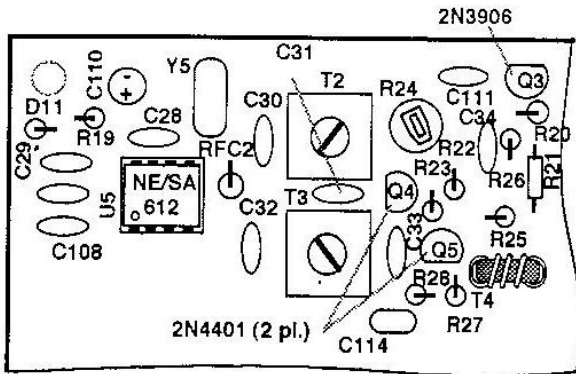

Group 5 assembly  
-reference only-

Transformer T4 (grey core) is wound with 6" (15cm) of magnet wire for the primary winding. The primary winding is wound first, using 8 turns. Install T4.

[ ] Add a secondary winding to T4 as follows:

- 1) Strip 1/8" of insulation from one end of the 3" length of insulated wire. Twist the wire gently between your fingertips to ensure that all strands are bundled together. Tin this lead-end with solder.
- 2) Install this lead-end in S2 and solder.
- 3) Take the free end of this wire in the direction of S1 and then double it back through the hole in T4.
- 4) Draw the lead snug (not tight!) and proceed around the toroid material until you've formed one complete turn through the toroid as shown below:

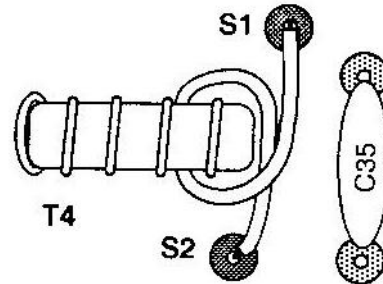

detail- T4 secondary winding

- 5) Trim off the free end of the wire so that it has about 1/4" (6mm) more than is needed to reach pad S1. Repeat the lead preparation as in Step 1 above.
- 6) Install this lead-end in S1 and solder.

(When these components have been installed, the transmitter mixer, bandpass filter, and driver sections of the transceiver are complete.)

[ ] Install the components shown below:

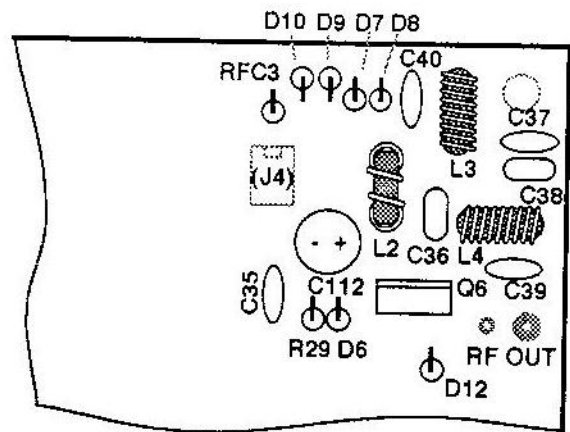

Group 6 assembly  
-reference only-

The following components are polarity-sensitive:

C112, D6-10, D12, Q6

- Q6 (2SC2166) is installed with the metal tab to the rear (or 'top' when viewed from directly overhead). When viewing the board from the front edge (U1, U3, and U4 nearest you), Q6's labeling must be visible.

- L2 is wound using 6" (15cm) of wire on an FT37-43 (grey) core. Wind 10 turns on this core, prepare lead ends, and install on the board.
- L3 and L4 are each wound using 14" (35cm) of wire on a T37-2 (red) core. Wind each with 22 turns, prepare lead ends, and install each of these on the board.

*(When these components have been installed, the board assembly is complete.)*

If you have not already done so, install all integrated circuits on the board as indicated on page 8. Be sure that the ICs are oriented properly – the dot or notch is on the left side of the 8-pin DIP ICs as shown on the pictorial.

**CLEAN UP YOUR ACT!** Before you install the finished PC board into an enclosure, grab some cotton swabs and use acetone (nail polish remover) to remove solder flux from the foil-side of the PC board. The result is a much cleaner appearance once you've completed this step.

## Wiring the SW-80+

The figure below shows the schematic interconnect between the SW-80+ board and the outside world (more on alignment later).

Short, direct leads between the SW-80+ board and your connectors and controls are advisable. If you're going to run the RF output more than a couple of inches to an antenna jack, coax (such as the subminiature RG-174) is recommended. The other interconnect wiring is less critical, but try to avoid routing the wiring over the audio (U4) filter section if possible.

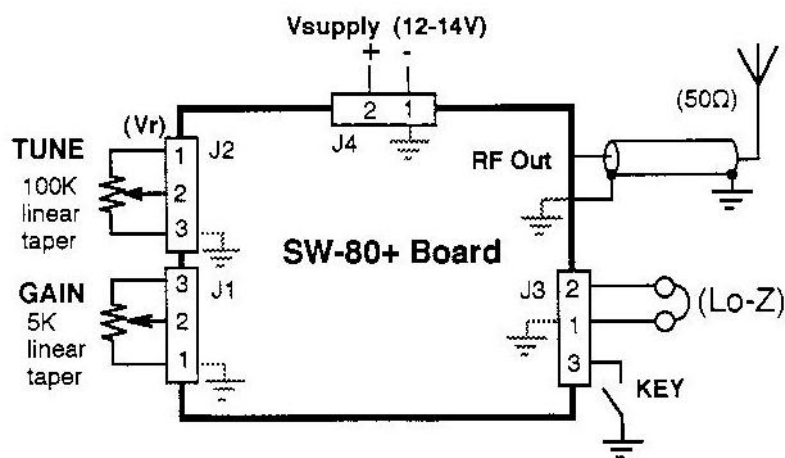

Wire the connectors and controls to the SW-80+ as shown pictorially below. Note that the keying return line lacks its own distinct board connection. This return line is shared with the headphones' return.

**STOP!**

Before you progress to the next phase of the project, this might be a good time to check out the SW-80+. Add the various connectors and controls using temporary leads before you get the project buttoned up in a box. If you need to do any troubleshooting, you'll have saved the aggravation of having to undo all the wiring to get at the bottom side of the board!

### “SW-80+” Mechanical Details

The pictorial figure below shows some ideas for connectors and their accompanying mounting-hole diameters. These are merely suggestions and are a matter of personal preference.

The board itself is mounted in an enclosure at the board's four corners using #4 machine screw hardware. #4 spacers should be used to separate the PC board from the enclosure by 3/16" or more. (#4 hex nuts are an acceptable substitute for spacers.)

Enclosures may be found in a variety of styles. Radio Shack offers several types of metallic enclosures. I'd especially recommend Hosfelt Electronics, Inc., who carry enclosures offered by a number of companies. There's no minimum order, and they can be reached at (800) 524-6464 for a catalog. Ten-Tec also offers a complete line of enclosures, and they support small orders as well. Call (800) 231-8842 for a free brochure.

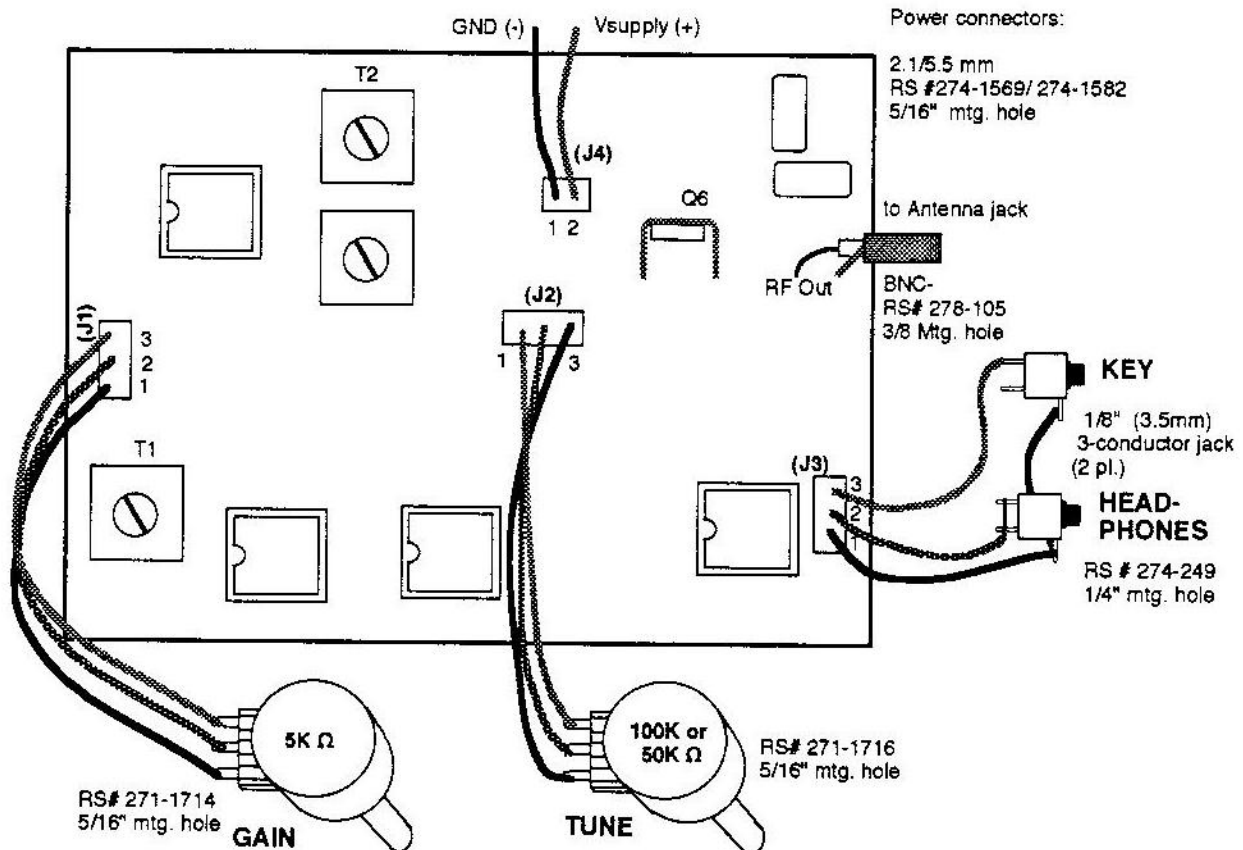

**Before the “Smoke Test”:**

- Inspect your work to ensure there are no solder bridges or unsoldered joints. Check to see that the ICs are mounted in their proper orientations.

**Alignment**

Alignment is easy with this little rig. For test equipment, you’ll need a main-station rig and multimeter or SWR bridge. Here’s how:

*Transmitter alignment:*

- [ ] Connect a tuning pot to J2. (See page 13 for interconnect pictorial.) Set the tuning pot to full counterclockwise (0V on the pot’s center terminal).
- [ ] Connect a 50Ω dummy load to ‘RF Out’ and its adjoining ground return pad.
- [ ] Set trimmer R24 to its one-third-scale (‘2 o’clock’) position. **Do not exceed the half-scale position until T2 and T3 have been peaked to maximum.** Yes...you may have to ‘hunt’ for an output power indication!- those two adjustments peaks are fairly narrow.
- [ ] Using a small slot screwdriver, preset the tuning slugs in T2 and T3 to the middle of their rotation range. *(This is non-critical; there’s no need to count turns.)*
- [ ] Add a clip lead to R29 (see figure below) to serve as a short whip antenna. Leave the other end of the clip lead unconnected, and ensure that this free end is well away from other circuitry.

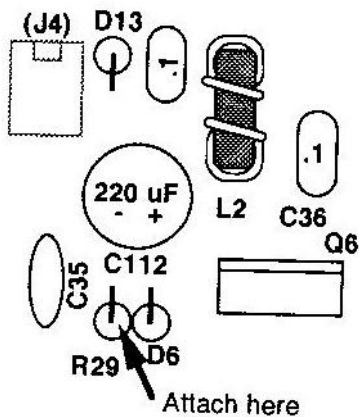

- [ ] Apply DC power (J4)
- [ ] Ground the “Key” (J3-3) input.
- [ ] Tune in your transmitted signal on your “big rig” receiver. This should be a strong carrier (S9+20 or better).

Be sure to hunt for the strongest signal over a range of 3.3 to 3.5 MHz [3.5 to 3.7 Mhz for Novice operation] to ensure that you find the primary signal instead of a receiver spurious response.

*If you don’t have general-coverage receiver capability, you may want to ‘get into the ballpark’ with C7 by placing sample values in its two component pad locations without soldering. Light finger-pressure on the cap will ensure that the component leads make contact with the board pads . Once you find the signal within the ham band, this’ll let you know where to start with the calibration tables below.*

Note: This rig tunes backwards because of the relationship between the LO and IF. Decreasing the LO frequency increases the operating frequency

**Operating frequency adjustment:**

- [ ] Note the frequency from the step above. Remove power and install a value of C7 in accordance with one of the tables below.
  - You can temporarily “try out” different values of C7 by simply placing the capacitors in the C7 mounting location without soldering. Adjustment of the capacitor lead spacing should provide enough tension to hold the capacitor in place temporarily.

**For 3.50 – 3.55 MHz operation:**

If the frequency was between	Install the following value for C7
3500-3530	(none)
3475-3500	10 pF
3450-3475	22 pF
3425-3450	33 pF
3400-3425	47 pF
3360-3400	68 pF
3320-3360	82 pF
3280-3320	100 pF
3240-3280	120 pF

**For 3.675 – 3.725 MHz operation:**

If the frequency was between	Install the following value for C7
3675-3700	(none)
3650-3675	10 pF
3625-3650	22 pF
3600-3625	33 pF
3575-3600	47 pF
3540-3575	68 pF
3500-3540	82 pF
3460-3500	100 pF
3400-3260	120 pF

(The approximate formula for the value of C7 is as follows:)

$$\Delta f \text{ (KHz)} = 2.2 \times [C7] \text{ (in pF)}$$

where  $\Delta f$  is the desired frequency shift

It's possible to adjust the operating frequency as much as 30 kHz downward by squeezing L1's turns more closely together.

Connect the RF output to a wattmeter (if you have one). You can also use your SWR meter with a dummy load connected and set in the "Forward" metering position.

If you don't have either of these pieces of equipment, you can 'haywire' the test circuit below on a scrap of copper-clad board. This peak detector circuit furnishes a DC voltage to your multimeter.

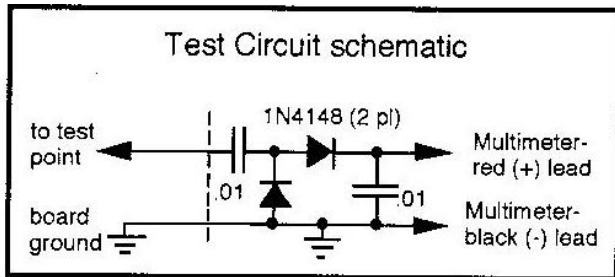

Adjust T2 and T3 for maximum indicated signal on your receiver's S-meter. The adjustment will be somewhat interactive, so alternate between the two for maximum output.

- [ ] Remove the clip lead. Adjust trimmer R24 as needed for 1.5 watts of key-down power into a dummy load or the test circuit shown on the previous page. (For the test circuit above, this corresponds to a DVM measurement of 12V DC). Increase drive (turn R24 clockwise) only as needed to get to this level.

**“Can I set it for more output power?”**

Sure! The component values in the PA stage were designed for maximum efficiency at 1.5W out. The SW+ will deliver considerably more, but please be aware of the following:

- The higher the output power, the more heat is being generated by the PA, and this translates into 'driftier' performance in the local oscillator.
- There's a possibility of instability in the driver (Q4/Q5) stage with R24 set to maximum. IF THE SIDETONE SOUNDS RASPY OR VANISHES ENTIRELY, reduce the R24 setting.

**Receiver alignment:**

- [ ] Connect a matched antenna to "RF Out" and its ground return. Using a small slot screwdriver, peak T1 for maximum signal (or noise). Once this step is complete, background noise should be noticeably higher with an antenna connected than without.

That's it – you're on the air!

**Troubleshooting the SW-80+**

The "bugs" you're most likely to encounter often turn out to be caused by the simplest of problems. If your SW-80+ doesn't play, the following general suggestions may be helpful:

*“It works better plugged in!”*

We've all heard that expression before, but unfortunately it's true. Ensure that DC power is getting to the SW-80+. A board with no voltage anywhere probably isn't getting power.

*“The headphones are silent!”*

It's probably the same as above – an interconnect problem. The 1/8" (3.5mm) jacks in particular are trouble-prone. Check once more for solder bridges and missing solder joints. Probing a suspect section of the circuitry with a fingertip or insulated tool will sometimes bring a stubborn circuit to life – if so, check again for a bad connection!

*Of the returns I see, about 85% of problems are caused by cold solder joints, 5% by solder bridges, and 5% due to incorrect resistor installation. That leaves only 5% for all the other problems put together! 'Nuff said.*

Ensure that ICs are installed in the correct location and with the right orientation.

Likewise, ensure that the transistors and all diodes are installed with the correct orientation.

If you don't turn up anything with the above steps, see the troubleshooting schematic on the last page of this manual. Using a DVM, check the circuit points noted on the drawing against your SW-80+ to confirm that the DC voltage readings are all in order.

*Here's a rule of thumb for the troubleshooting voltages: I've supplied the nominal voltage readings, but there's some unit-to-unit variation. As an overall guideline, a 20% variation is an acceptable tolerance. If you're making use of this schematic, "something's broke", and things don't generally break just a little; you're looking for the obvious departures from the published values.*

The troubleshooting schematic also lists AC voltage readings in case you have access to an oscilloscope or have a high-impedance input RF probe. Readings are given in Volts p-p.

- The figure below illustrates IC pinout. The "pin 1 at lower left" convention applies to all Dual-In-Line-Package (DIP) ICs.

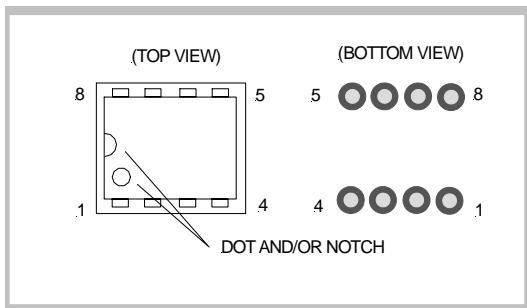

**“Strange but True”** – In general, the ICs themselves shouldn't be prime suspects during the troubleshooting

*process. Despite their complexity, they're very reliable, and I've had to replace these parts at the rate of only 1 for every thousand or so shipped!*

*If those steps don't turn up anything, here are some additional steps to try:*

## Receiver

- Touching either of the 10K resistor leads to the left of the AF Amp IC (U4) should cause an easily-audible hum or buzz in the headphones. If not, and Vr (the 8V supply) is OK, the NE5532 op amp (U4) is suspect.
- Touching an antenna wire to the 470Ω resistor to the left of U3 (product detector) should cause shortwave “crud” to be audible in the headphones

## Transmitter

**Be sure a load is connected anytime you're troubleshooting the transmitter.**

- Verify that the keying switch Q3 supplies 12V DC to the transmit mixer (U5) and buffer/driver (Q4-5) stages when the “Key” input is grounded. Note that the voltage reading at pin 8 of U5 should be 7.1 to 7.9 volts. No voltage during key-down suggests that Q3 is bad or that D11 is installed backward.
- Touching a screwdriver to Q6's case (collector) should yield a distinct (key-down) increase in signal received on your ‘big rig’ receiver. If not, suspect Q6.

*If you want to change the sidetone pitch, increasing the value of C29 raises the sidetone pitch (and Tx offset), and decreasing that cap lowers it.*

## Don't panic!

If all else fails, contact me for further technical support:

Email: [dave@smallwonderlabs.com](mailto:dave@smallwonderlabs.com)

Troubleshooting/alignment is available for a \$30 fee (\$35 outside the US) . The unit will be returned to you in working condition and will include a troubleshooting report. The price includes return shipping.

**Please do not send the unit without contacting me first.**  
*Repair work is done off-site- and people move!*



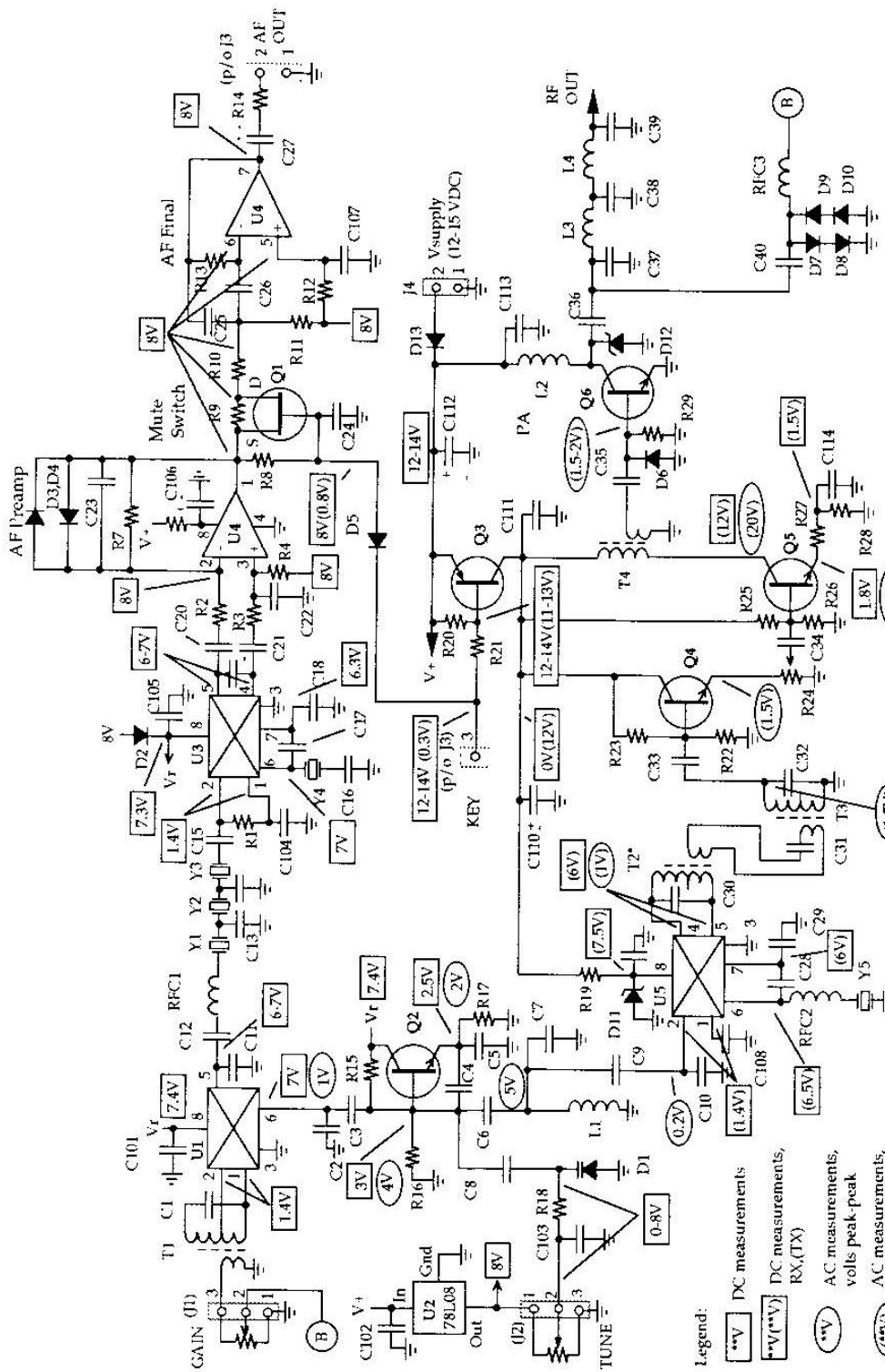

**Troubleshooting the SW-80+ "Transceiver"**  
SMALL WONDER LABS™  
 3/10/98