

Building the Splinter II QRPp Receiver-Transmitter kit

Thank you for purchasing your Breadboard Radio “Splinter II” QRPp receiver-transmitter kit. These instruction pages will guide you through all the steps to insure that you end up with an attractive and functional project. Please read and follow these instructions completely.

A Brief Description

The original Splinter actually started out as a club project for the Columbia (SC) Amateur Radio Club to help new hams to learn morse code. Originally it started as a code practice oscillator. It was then decided to include a simple receiver so that code practice could be received. Finally, why not add a simple transmitter? That CPO that started it all became the sidetone for the transmitter. Everything during the prototyping was built on a wooden breadboard using brass tacks as soldering points...thus the inspiration for our name...Breadboard Radio and the model “Splinter.”

The Splinter II is basically the same design as the original with several improvements that make your QRPp operation even more successful and fun.

1. The audio amplifier has been improved by changing the audio filtering to a simpler design resulting in more audio and better potentiometer control.
2. The sidetone which was originally fed directly to the audio output now goes to the input of the audio amplifier. The sidetone level can now be controlled by the volume control.
3. A switching transistor has been added to the keying circuit. This eliminates the possibility of shorting the DC to ground when using an external key. It also allows the use of most electronic keyers.
4. The transmitter’s final amplifier transistor has been changed to a more robust 2N3053. This device runs cooler while delivering 100 to 200 more milliwatts of output power if desired.
5. The VXO has been redesigned to deliver about six kilohertz of swing from most HC-49 crystals!

What You Can Expect

In testing, the original Splinter was used with a 12 volt power supply and a Cushcraft D4 rotary dipole (40 ft. long trap dipole on a rotator) at 55 ft. on a tower for about a month. During this test period W4FSV worked 10 states and Cuba, England, Romania and Italy...not bad for this simple little set-up. If we can do it, you can too! It only takes patience, persistence and a decent antenna...not luck. With a half watt you won’t get an answer after every CQ or every CQ you answer, but those contacts you do make will truly be rewarding. You can expect similar results with the Splinter II.

The Rules

1. Take your time. We recommend that you take at least three or four days to complete your kit. It will take three coats of paint on your breadboard anyway to give it a good finish and a day of drying between each coat is recommended. So, if you take your time, in three days you can have a beautiful working project that you will be proud to own and operate.
2. If you don’t know how to solder parts on a circuit board, get help. Learning to solder is not hard, but please do not start this kit if you have never soldered before!
3. Most of the parts are tiny. Please use a magnifying glass.
4. Build the kit by the instructions, one section at a time and test each section as it is finished.
5. Use protective eyewear.
6. Be careful with the ICs and transistors to avoid damage from static.

7. All parts should be mounted flush or as close as possible to the circuit board keeping leads short. After soldering, clip all wires close to the board.

Finishing Your Breadboard

The wooden breadboard furnished with your kit is your opportunity to express yourself. You get to finish it any way that you like...pick your color, pick your finish. MAY WE SUGGEST THE FOLLOWING?

1. Use fine grit sand paper to remove any roughness from the wood.
2. You can use brush on or spray paint or stain or no finish at all...it's up to you.
3. You are in charge of getting the board ready. Three coats with light sanding between coats and about 24 hours of drying time will produce great results. NOTE: The decals that will be placed on your breadboard at the end of kit construction are black and red. SO, it is best to use a lighter color (e.g. white, grey, yellow, light green or blue).
4. When the board is finished, locate the circuit board and place it on top of the breadboard. Center the circuit board and using a small nail, phillips screwdriver or other small pointed object, push a small starter hole into the breadboard at each corner mounting hole. The starter hole will help you to mount the assembled circuit board in the proper location at the end of the project. Place the breadboard aside for now.

Building the Circuit Board

Tools and supplies needed to build the circuit board:

1. needle nose pliers
2. diagonal cutters
3. small flat blade and phillips screwdrivers
4. Magnifying glass
5. 35-40 watt soldering iron
6. 60/40 thin resin core solder
7. Fine sand paper

The board is assembled in four sections. Each section's parts are packed in plastic bags.

Parts List

All leaded resistors are 1/8 watt 5%

R1....1K trimmer potentiometer

R2....1M

R3....470K

R4....10K audio taper potentiometer

R5....3.3K

R6....47K

R7....680

R8....100K

R9....33K

R10..10K

R11..2.2K

R12..470

R13..300K

R14..50K linear taper potentiometer

R15..1K
R16..56K
R17..100
R18..36K
R19..470
R20..39
R21..4.7K
R22..1K

All capacitors are ceramic disc unless otherwise noted

C1....56pf npo
C2....0.1uf
C3....0.1uf
C4....47uf electrolytic
C5....0.047uf
C6....0.1uf
C7....0.01uf
C8....0.01uf
C9....10uf electrolytic
C10..270pf npo
C11..270pf npo
C12..150pf npo
C13..39pf npo
C14..0.001uf
C15..0.022uf
C16..0.1uf
C17..0.1uf
C18..82pf npo
C19..5-40pf trimmer
C20..150pf npo
C21..0.1uf
C22..0.1uf
C23..47uf electrolytic
C24..0.1uf
C25..390pf npo
C26..0.1uf
C27..0.1uf
C28..820pf npo
C29..390pf npo
C30..150pf npo

Semiconductors

D1....6.2 volt zener diode
D2....1N4001
D3....1N4001
Q1....2N3904
Q2....2N3904
Q3....2N3053
Q4....2N3906
IC1...SA612
IC2...TL431

Inductors

T1....slug tuned IF can
L1....slug tuned IF can
L2....22uh molded choke
L3....1.0uh molded choke
L4....1.0uh molded choke

Switches and connectors

SW1..single pole double throw slide switch
SW2..momentary contact tactile switch (red button)
SW3..double pole double throw slide switch
SW4..momentary contact tactile switch (4 solder tabs)
J1.....1/8 inch phone jack
J2.....2 position screw terminal
J3.....RCA phono jack
J4.....1/8 inch phone jack

Hardware, etc.

Circuit board
Breadboard
4 brass wood screws
4 black plastic spacers
2 white plastic spacers
4 black rubber feet
1 white key
1 black square rubber bumper for key
Decals
2 #4 nylon washers
2 #4 machine screws
2 control knobs
2 sip sockets
Y1 7030 KHz crystal

CONSTRUCTION

Bag #1 (Power Supply and Switching Circuits)

Locate the bag labeled #1. All of the parts required for this section of construction are enclosed. You can work from the bag and find each part as it is called for, but placing all of the parts from the bag into a bowl or small plastic tray may make it easier to sort and properly identify the parts.

As each part is called for, be sure to identify it, then locate the proper mounting holes on the board. Insert the part and check its placement before soldering it in place.

1. Locate diode D3 (1N4001) and bend the leads 90 degrees in the same direction so that they will fit the holes on the circuit board. NOTE: D3 is located about in the middle and near the back edge of the board. The stripe on the diode goes towards Q3. Save the cut off leads...they will be used in a later step.
2. Locate screw terminal J2 and the mounting position on the top side of the board near D1. Place J2 in the two mounting holes with the wire insertion holes facing off the back of the board. You can slightly bend the leads on the bottom of the board to help keep J2 flush to the top of the board. Solder the two leads.

3. Locate SW1 and it's mounting holes at the back of the board to the right of J2. Place the switch in the holes and solder in place keeping the switch flush with the board.
4. Locate SW3 and mount it in it's position on the front edge of the board. NOTE: SW3 is a very tight fit. Be careful to align the 10 pins of the switch so that they all go through the proper holes. This may require slight bending of the four larger outside pins. Once mounted and flush with the board, solder the ten pins on the bottom of the board.
5. Locate SW4 (4 pin push button tactile switch) and it's mounting position at the front right corner of the board. Using needle nose pliers, straighten the mounting tabs. One side of the switch is slightly wider than the other due to the mounting tabs and the switch must be mounted with the longer side (tab sides) going from front to back. This switch will also require some TLC to get a proper fit and must fit flush against the top of the board so that the arm of the key will meet the push button properly. Once in place solder the four pins to the board.
6. Locate J4 a 1/8th inch phone jack and it's mounting position on the right edge of the circuit board. Refer to diagram 1 and modify the two lower soldering lugs to fit in the two mounting holes closest to the left side of the board. Bend the lower back lug (lug B) 90 degrees so that it points down like the front lug. Using diagonal cutters, clip off the ends of lugs A and B as close as possible to the soldering hole. The remaining lugs should be as long as possible so that they will fit through the mounting holes in the circuit board. Place J4 into position with lug A and B in the mounting holes and solder with J1 flush against the board. The lugs may need slight trimming with the diagonal cutters to fit the holes. Lug B may not come all the way through the hole, but a little extra solder to fill the hole will sufficiently hold it in place. Use one of the wire leads saved from step one to complete mounting J4. Pass one end of the wire through lug C of J4 and into the circuit board mounting hole. Secure the top end of the wire to lug C of J4 and solder in place. Solder the other end of the wire on the bottom of the board and clip the excess wire.

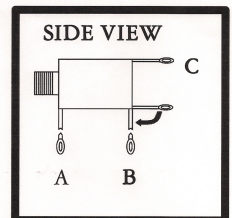
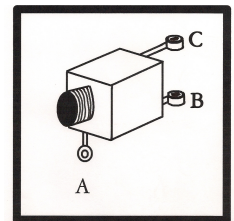

7. Locate zener diode D1 (glass zener diode) and it's mounting position. Mount the diode with the stripe on the diode on the right side as indicated on the circuit board. Solder in place.
8. Locate, mount and solder 10uf. electrolytic capacitor C9. The positive lead is longer than the negative lead and goes in the positive hole indicated by the + sign and square outlined hole.
9. Locate, mount and solder 0.1uf. (104) ceramic capacitor C16. Use a magnifying glass if needed to read the value on the side of these small capacitors. This 0.1uf capacitor is coded: 104.
10. Locate, mount and solder 47uf. electrolytic capacitor C23. Observe polarity.
11. Locate, mount and solder 0.1uf. (104) ceramic capacitor C27.
12. Locate, mount and solder 0.1uf. (104) ceramic capacitor C26.
13. Locate, mount and solder 0.1uf. (104) ceramic capacitor C17.
14. Locate, mount and solder 470 ohm (yellow, violet, brown) resistor R19.
15. Locate, mount and solder 1K ohm (brown, black, red) resistor R22.
16. Locate, mount and solder 4.7K ohm (yellow, violet, red) resistor R21.
17. Locate, mount and solder 680 ohm (blue, gray, brown) resistor R7.
18. Locate, mount and solder transistor Q4 (2N3906). The flat side of the transistor faces to the front side of the board as indicated on the board. Do not push the transistor flush to the board or the leads may break. The transistor should be about 1/8th inch off the board.
21. Locate, mount and solder R14 (50K ohm linear potentiometer). Be sure that this parts mounting legs are flush against the board.

Congratulations...you have finished the first stage of your Splinter! Now, let's test it since it will be easier to find a mistake now rather than when all the parts are mounted.

- A. First look over your work to insure that all parts are in the correct places and all solder connections are good.
- B. Set the arm of SW1 (on-off) to the right (off). Set the arm of SW3 (receive-transmit) to the left (receive).

- C. Connect 9 to 12 volts D.C. to Power Terminal J2. Be careful to observe proper polarity. Looking at the back of the board, the positive wire goes in the right side terminal and negative goes in the left side terminal.
- D. Slide switch SW1 to the left (on). Observe for any signs of shorts or overheating. Disconnect power if any problems are observed.
- E. If a voltmeter is available, connect the negative lead to the right back corner mounting hole and the positive lead to the right side of zener diode D1. The measured voltage should be approximately 6.2 volts with SW3 in the receive position (to the left). If the voltage at D1 is above 7.0 volts, check your work for shorts, parts placement, parts values and solder connections.
- F. Set the arm of SW1 (on-off) to the right (off). Set the arm of SW3 (receive-transmit) to the right (transmit).
- G. If a voltmeter is available, connect the negative lead to the right back corner mounting hole and the positive lead to the right side of the L2 mounting hole. Slide switch SW1 to the left (on). Press key switch SW4. The voltage should measure approximately the same as the voltage applied to J2. If the voltage is good, disconnect the power and proceed to the next bag of parts.

Bag #2 (Audio Amplifier and Sidetone)

In the following steps locate the indicated part and it's mounting position. Then solder the part in place. Exceptions will be noted.

- 1. C3 ceramic capacitor 0.1uf. (104)
- 2. C4 electrolytic capacitor 47uf. observe polarity
- 3. C5 0.047uf (473)
- 4. C7 0.01uf (103)
- 5. C8 0.01uf (103)
- 6. C14 0.001uf (102)
- 7. C15 0.022uf (223)
- 8. R2 1M ohm resistor (brown, black, green)
- 10. R3 470K ohm resistor (yellow, violet, yellow)
- 11. R4 Locate, mount and solder R4 (10K ohm Audio potentiometer). Be sure that this parts mounting legs are flush against the board
- 12. R6 47K ohm resistor (yellow, violet, orange)
- 13. R8 100K ohm resistor (brown, black, yellow)
- 14. R9 33K ohm resistor (orange, orange, orange)
- 15. R10 10K ohm resistor (brown, black, orange)
- 16. R11 2.2K ohm resistor (red, red, red)
- 17. Q1 2N3904 transistor. Mount with the flat side facing towards the right side of the circuit board as indicated on the board. Do not force the transistor flush to the board...leave the leads about 1/8th of an inch long.
- 18. IC2 TL431 op amp (looks like a transistor). Mount with the flat side towards the front as indicated on the board. Leave the leads about 1/8th of an inch long, like in the last step. CAUTION: This device is static sensitive...touch a metal surface to discharge yourself before mounting.
- 19. J1 1/8th inch phone jack. Install same as J4.

Congratulations...the amplifier and sidetone section of your Splinter is complete. Now, let's test it!

- A. First, check all of your work. Parts in correct places, correct values, polarity on electrolytic capacitors, no shorts and good solder connections.
- B. Set the arm of SW1 (on-off) to the right (off). Set the arm of SW3 (receive-transmit) to the right (transmit). Connect earphones / earbuds to J1.

- C. Connect 9 to 12 volts D.C. to Power Terminal J2. Be careful to observe proper polarity. Looking at the back of the board, the positive wire goes in the right side terminal and negative goes in the left side terminal.
- D. Slide switch SW1 to the left (on). Observe for any signs of shorts or overheating. Disconnect power if any problems are observed.
- E. Press SW4 (key switch). Sidetone should be heard in earbuds.

Bag #3 (Receiver Oscillator / Mixer and Transmitter)

1. Locate, mount and solder IC1. Before handling this IC, touch a large metal object such as a table leg or a grounded object in order to discharge any static from yourself. You will need to slightly bend the legs on each side of the IC to facilitate fitting into the parallel rows of mounting holes.

In the following steps locate the indicated part and it's mounting position. Then solder the part in place. Exceptions will be noted.

2. C1 ceramic capacitor 56pf. (560) NPO
3. C2 ceramic capacitor 0.1uf. (104)
4. C6 ceramic capacitor 0.1uf. (104)
5. C10 ceramic capacitor 270pf. (271) NPO
6. C11 ceramic capacitor 270pf. (271) NPO
7. C12 ceramic capacitor 150pf. (151) NPO
8. C13 ceramic capacitor 39pf. (390) NPO
9. D2 1N4001 rectifier diode. Observe polarity of diode (line on diode goes towards C18)
10. R5 3.3K ohm resistor (orange, orange, red)
11. R13 300K ohm resistor (orange,black,yellow)
12. T1 42IF223 slug tuned transformer
13. L1 42IF223 slug tuned transformer
14. R1 1K ohm linear trim potentiometer

The receiver will be tested at the end of Bag #3 parts placement.

In the following steps locate the indicated part and it's mounting position. Then solder the part in place. Exceptions will be noted.

1. R12 470 ohm resistor (yellow, violet, brown)
2. R15 1K ohm resistor (brown, black,red)
3. R16 56K ohm resistor (green, blue, orange)
4. R17 100 ohm resistor (brown, black, brown)
5. R18 36K ohm resistor (orange, blue, orange)
6. R20 39 ohm resistor (orange, grey, black) SEE NOTE #1
7. C18 ceramic capacitor 82pf. (820) NPO
8. C20 ceramic capacitor 150pf. (151) NPO
9. C21 ceramic capacitor 0.1uf (104)
10. C22 ceramic capacitor 0.1uf. (104)
11. C24 ceramic capacitor 0.1uf. (104)
12. C25 ceramic capacitor 390pf. (391) NPO
13. C28 ceramic capacitor 820pf. (821) NPO
14. C29 ceramic capacitor 390pf. (391) NPO
15. C30 ceramic capacitor 150pf. (151) NPO
16. L2 epoxy choke (red, red, black, gold) (looks like a resistor, but fatter)
17. L3 epoxy choke 100uh. (brown, black, gold, gold)

18. L4 epoxy choke 100uh. (brown, black, gold, gold)
19. Y1 sip sockets (2) These may require a little force to all the way down the holes. After soldering, clip off the skinny part of the sockets. (These sort of look like the tips of ball point pens.)
20. Q2 2N3904 transistor.
21. Q3 2N3053 transistor. Leave leads about 1/8th inch long so that transistor is off the board and air can move under the transistor. CAUTION: Do not allow the L3 choke lead to touch Q3. It is close and could short if allowed to touch!
22. J3 RCA jack (antenna jack) Clip off the two small yellow plastic stubs on the bottom to allow the jack to sit flush on the circuit board.
23. SW2 small push button tactile switch with red button.
24. Prepare C19 Small 4-40 pf. variable capacitor (trimmer). Place one end of the 3/8 inch white nylon spacer onto the small brass shaft of the trimmer capacitor...use steady moderate pressure until the end of the spacer is on the shaft all the way to the white insulator disc. Then place the red soft plastic bolt protector over the spacer...you can make the fit easier by first heating the red bolt protector in warm water. SEE DETAIL.
25. Mount C19 in the indicated holes. The stiff two leaf tab goes in the hole above the VXO lettering.

VXO Capacitor Assembly

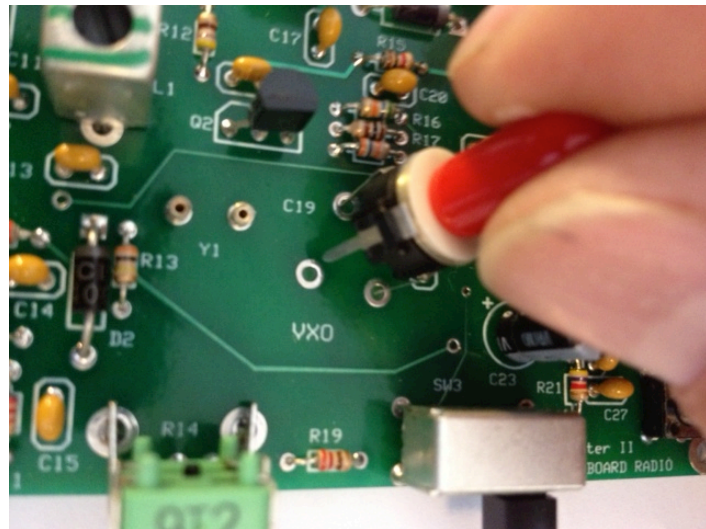
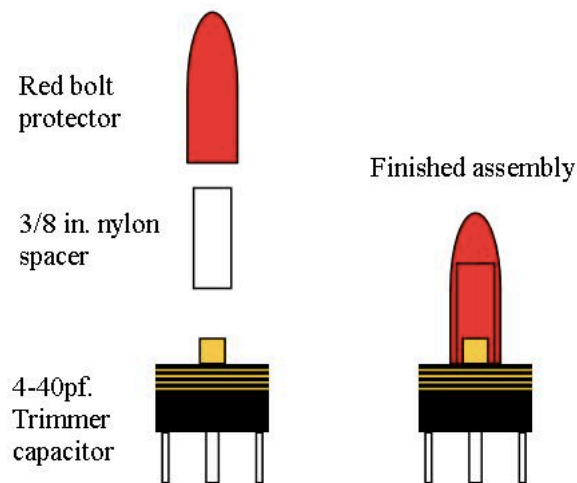

Receiver Testing and Alignment

- A. First look over your work to insure that all parts are in the correct places and all solder connections are good.
- B. Plug in a earphone, headphones or ear buds into J1. Set the arm of SW1 (on-off) to the right (off). Set the arm of SW3 (receive-transmit) to the left (receive). Set the Tune control (R14) to the center position and the A.F. Gain (R4) fully clockwise. Set the attenuator (R1) fully counter clockwise. Place the supplied 7030kHz crystal in the sip sockets at Y1.

- C. Connect 12 volts D.C. to Power Terminal J2. Be careful to observe proper polarity. Looking at the back of the board, the positive wire goes in the right side terminal and negative goes in the left side terminal.
- D. Slide switch SW1 to the left (on). Observe for any signs of shorts or overheating. Disconnect power if any problems are observed.
- E. While listening, press the spot switch (SW2) and with a small jewelers flat blade screwdriver, slowly move the slug in L1 (IF can below D1) up and down. At some point you will hear a tone which will rise and fall as you move the slug. Zero beat this tone (The point where the tone goes as low as possible before starting to rise again). The receiver is now on 7030 KHz.
- F. Connect an antenna to the antenna jack. You should be able to hear signals. While listening to a weaker signal, use the jewelers screwdriver to move the slug in T1 (IF can below R1) up and down. Adjust this slug for maximum signal strength.

Your Receiver is now aligned.

Bag #4 (Hardware and Final Assembly)

The key is mounted to the circuit board with two 1/2 inch #4-40 machine bolts and white 3/8th inch white plastic spacers. The bolts will self tap into the holes...be careful not to over tighten and strip the holes. The bolts should just protrude from the bottom of the board. The key is supplied pre-drilled, but may require some fit adjusting. The mounting holes may need to be slightly enlarged with a small rat tail file or xacto blade tool. The rear of the key should just touch J4 and can be sanded if needed for fit. The finished key should just touch the button of SW4. You may clean-up the edges of the key with light sand paper. When satisfied, place the black square rubber stick-on bumper on the end of the key to serve as a finger riser (knob). SEE DETAIL.

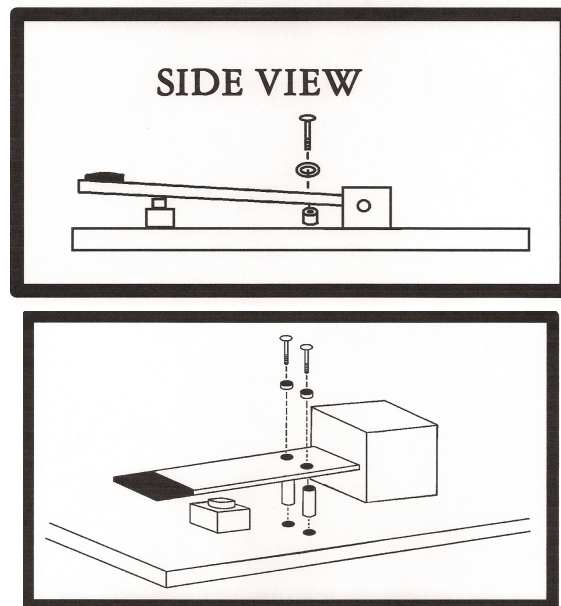

Mount the circuit board to the breadboard with four 1/2 inch brass wood screws and black 3/8th inch plastic spacers. You should have starter holes on the breadboard (Breadboard step 4.) You may need to loosen or remove the key to get the front right screw in.

Mount the decals on your finished breadboard. Cut the decals out with scissors and place in warm water for about ten seconds. Place the wet decals on the breadboard in the correct place and slide the backing away. Carefully align the decals and allow them to dry.

Place the two knobs on the shafts of R4 and R14.

Place the four black stick-on bumpers (feet) on the bottom corners of the breadboard.

Testing the Transmitter

- A. First look over your work to insure that all parts are in the correct places and all solder connections are good.
- B. Plug in a earphone, headphones or ear buds into J1. Set the arm of SW1 (on-off) to the right (off). Set the arm of SW3 (receive-transmit) to the right (transmit). Set the Tune control (R13) to the center position and the A.F. Gain (R4) fully clockwise. Set the attenuator (R1) fully counter clockwise.
- C. Connect 12 volts D.C. to Power Terminal J2. Be careful to observe proper polarity. Looking at the back of the board, the positive wire goes in the right side terminal and negative goes in the left side terminal.
- D. Slide switch SW1 to the left (on). Observe for any signs of shorts or overheating. Disconnect power if any problems are observed.
- E. Connect a 50 ohm dummy load to the antenna jack. If a watt meter is available, it can be placed between the antenna jack and the dummy load. Alternately, an antenna for 40 meters can be attached, BUT make sure that the SWR is below 2:1 before transmitting! Press the key. The sidetone should be heard in the earphones and RF output should be seen on the watt meter (if connected). DO NOT hold the key down for more than a few seconds!
- F. Using a nearby receiver, listen to the transmitted signal at approximately 7030 KHz. The tone should be loud and chirp free. Turn C19 (VXO capacitor) and while depressing the key rotate the capacitor. The frequency in the receiver should move up and down several KHz.

Your Splinter is now complete!

NOTE #1:

R-20 controls the bias of final amplifier transistor Q3. The value of 39 ohms will allow the final to produce around 500 mw with a DC power supply of 13.8 volts. Actual power will depend on the individual transistor, impedance of the antenna, actual voltage, SWR, etc. You should use a directional watt meter designed for QRP such as the Oak Hills WM-1 to determine your actual power output. Be aware that rarely will any two watt meters give the same readings especially at QRP power levels. You can adjust R20's value up or down to produce more or less output from Q3, however, be aware that if you attempt to increase power output with a lower value at R20 you may destroy the moulded chokes in the collector / low pass filter.

Operational Notes

1. The Splinter will operate from about 9 to 13.8 volts. However, RF output will be about half at 9.0 vdc and the spot function may not operate at less than about 11.0 vdc.
2. The transmitter is not SWR protected...be sure that the antenna has an SWR of less than 2:1 or that an antenna tuner is used. A high SWR will damage the final transistor!
3. Although the VXO can be used to zero beat the transmit frequency on a received frequency, it was not actually included in the design for that purpose. The designed function of the VXO is to move the operating frequency slightly off the crystal frequency. Doing so may help lower QRM from too many

operators on the exact same crystal frequency. However, the Splinter II VXO works well enough to move the transmitted frequency about 1 kHz below and as much as 6 kHz above the marked crystal frequency. This allows you to spot the transmitter on a received signal within the VXO's range.

4. The Spot function (SW2) will be broad due to the wide band pass of the DC receiver. The Spot switch helps you get the receiver close to the transmit frequency. You should listen for calling stations on the lower side of zero beat (slightly to the left on the tuning dial). If spotting a CQ, zero beat the signal and then turn the VXO ever so slightly counterclockwise. You will need to experiment a little, but once mastered, you will enjoy greater operating flexibility than the original Splinter (and many other simple rigs)!
5. BE VERY CAREFUL not to drop anything metallic on the Splinter! Because of the open board design it is possible to short out the operating voltages to ground resulting in destruction of components or circuit board traces.
6. The on-board key works well, however, an external key can be used through J4. Also, most electronic keyers will work.
7. Use the antenna attenuator to reduce or eliminate broadcast interference if present. This control is also used to prevent overload from the occasional idiot running a kilowatt cw.
8. All DC receivers have broad selectivity. The Splinter uses RC circuitry to help, but expect QRM. Remember that you will be able to hear both sidebands...so the QRM may be avoided by tuning to the opposite side of zero beat. Also, an external audio cw filter can help.
9. A 7030 kHz crystal is supplied. Extra HC 49 type crystals can be used by plugging them into the board mounted crystal socket. If you intend to use the crystal often, you can cut the leads to 3/8 inch long. This will look neater and keep the crystal more stable. However, be sure that the leads are long enough so that the body of the crystal does not touch the crystal socket. Also, when changing crystals, first turn the Splinter off before handling crystals to prevent accidentally dropping one on the circuit board. A dropped crystal could short something out and damage your radio. After assuring that the crystal is properly in the socket, you can turn the Splinter back on.

Theory of Operation

Receiver

Signals from the antenna pass through the transmitters low pass filter and RX/TX switch SW3. Signals then pass through the attenuator R1 that acts like an RF gain control. Strong signals, such as short wave and nearby AM broadcast stations can be attenuated which allows desirable signals to be heard. T1 acts as an RF bandpass filter resonate at approximately 7.0 MHz. Signals in the bandpass are mixed in IC1 with the local oscillator signal generated by IC1 and the tuned circuit of L1, C10, C11 and C12. The resultant output of IC1 is in the audio range. Frequency tuning is accomplished with C13, R13, D2 and R14 which act to slightly vary the capacitance in the L1 circuit.

The audio from IC1 is internally pre-amplified and is shaped by some high and low pass filtering provided by the resistor and capacitor values ahead of IC2. Final audio amplification is provided by IC2 and it's associated parts including R4 which controls the output volume.

Transmitter

The keying circuit turns on and off the DC voltage to the sidetone, crystal oscillator and RF amplifier stages. The sidetone is generated by Q1 and associated components in a modified "twin-tee" circuit. The tone is capacitively coupled directly to IC2. The crystal oscillator and RF amplifier are modified from the OXO design introduced by G3OXO. The oscillator (Q2) is frequency controlled by Y1. C23 acts as a VXO to pull the oscillator crystal several to as much as 7 KHz off the stamped frequency (this swing will depend on many factors including the crystal activity). Spot switch SW2 and dropping resistor R16 provides just enough voltage to allow Q2 to oscillate while not keying the amplifier in the receive mode. The signal generated in the oscillator (Q2) is DC and capacitively coupled to the base of RF amplifier Q3

by R15 and C20. Q3 generates about 500 milliwatts of RF at the antenna jack. L3, L4, C25, C28, C29, and C30 comprise the lowpass filter and trap to provide at least -45 db of spurious and harmonic suppression.

Power Chain

DC input at J2 passes through D3 which protects against accidental polarity reversal. SW3 sends the DC to either the transmitter circuits or receiver circuits via D1, C9 and C16 which provide voltage regulation and filtering for the receiver components.

TIPS for Making Contacts

1. Use the best antenna you can. A dipole up high is a good choice for QRPp.
2. Use the V XO to move off of the common frequencies.
3. Choose an operating time when the band is less busy, don't even think about operating during a cw contest!
4. Piggy back on the end of a QSO. Call the loudest station just as they QRT.
5. Call CQ more than you answer a CQ.
6. Send slower than you usually do.
7. Keep it short unless you get a really good RST.

What if I Have a Problem

In the event that your Splinter fails to work properly, recheck your work and all solder connections. Try to isolate the problem to one stage. What works and what does not? Make sure all parts are in the right place. You may e-mail or phone us for help (email is preferred). w4fsv@breadboardradio.com phone 803-606-1812

Warranty

We will replace missing or defective parts free of charge. We will provide free e-mail and phone support.

If your Splinter needs to be returned, we will repair or replace at our discretion. You may be charged a small fee for repairs which are due to poor soldering, improper parts placement or physical damage.