



Antenna
(KRA-21:Option)

Knob assy (SEL)
(K29-5282-04)

Knob assy (VOL)
(K29-5283-04)

Panel assy
(A62-0779-03)

Knob assy
(Side key)
(K29-5423-04)

Cabinet assy
(A02-2139-63)

CONTENTS

GENERAL	2
SYSTEM SET-UP	2
OPERATING FEATURES	3
REALIGNMENT	10
CIRCUIT DESCRIPTION	12
SEMICONDUCTOR DATA	20
DESCRIPTION OF COMPONENTS	22
PARTS LIST	24
EXPLODED VIEW	31
PACKING	32
DISASSEMBLY FOR REPAIR	33
ADJUSTMENT	34
PC BOARD VIEWS	
FINAL UNIT (X45-3610-10)	43
CONTROL UNIT (X53-3930-10)	43
TX-RX UNIT (X57-608X-XX)	47
SCHEMATIC DIAGRAM	53
BLOCK DIAGRAM	59
LEVEL DIAGRAM	61
TERMINAL FUNCTION	62
KNB-17A (Ni-Cd BATTERY)	63
KMC-25A (SPEAKER MICROPHONE)	64
KSC-19 (CHARGER)	65
KSC-20 (RAPID CHARGER)	65
KPG-36 (PROGRAMMING INTERFACE CABLE)	65
KBP-4	65
SPECIFICATIONS	BACK COVER

Photo is TK-190 K type.
Does not come with antenna.
Antenna is available as an option.

CAUTION

When using an external power connector,
please use with maximum final module protec-
tion of 10V

GENERAL / SYSTEM SET-UP

INTRODUCTION

SCOPE OF THIS MANUAL

This manual is intended for use by experienced technicians familiar with similar types of commercial grade communications equipment. It contains all required service information for the equipment and is current as of the publication date. Changes which may occur after publication are covered by either Service Bulletins or Manual Revisions. These are issued as required.

ORDERING REPLACEMENT PARTS

When ordering replacement parts or equipment information, the full part identification number should be included. This applies to all parts : components, kits, or chassis. If the part number is not known, include the chassis or kit number of which it is a part, and a sufficient description of the required component for proper identification.

FCC COMPLIANCE AND TYPE NUMBERS

Model	Type acceptance number	Frequency range	Compliance
TK-190 K	ALH29521110	29.7~37.0MHz	Parts 22,90
TK-190 K2	ALH29521120	35.0~50.0MHz	Part 90

PERSONNEL SAFETY

The following precautions are recommended for personnel safety :

- DO NOT transmit until all RF connectors are verified secure and any open connectors are properly terminated.
- SHUT OFF and DO NOT operate this equipment near electrical blasting caps or in an explosive atmosphere.
- This equipment should be serviced by a qualified technician only.

SERVICE

This radio is designed for easy servicing. Refer to the schematic diagrams, printed circuit board views, and alignment procedures contained within.

Caution

Do not bring the antenna close to metallic objects.

Model & destination	Unit		X53-3930-10	X45-3610-10	Frequency range	Remarks	Charger	Battery	Antenna
	X57-608X-XX		0-10	0-10					
TK-190	K	✓	✓	✓	29.7~37.0MHz	IF1: 128.55MHz	OP	OP	OP
	K2	✓	✓	✓	35.0~50.0MHz	LOC: 129.005MHz	OP	OP	OP

Note : Internal beat interference exists at both 33.600MHz and 42.000MHz.

SYSTEMSET-UP

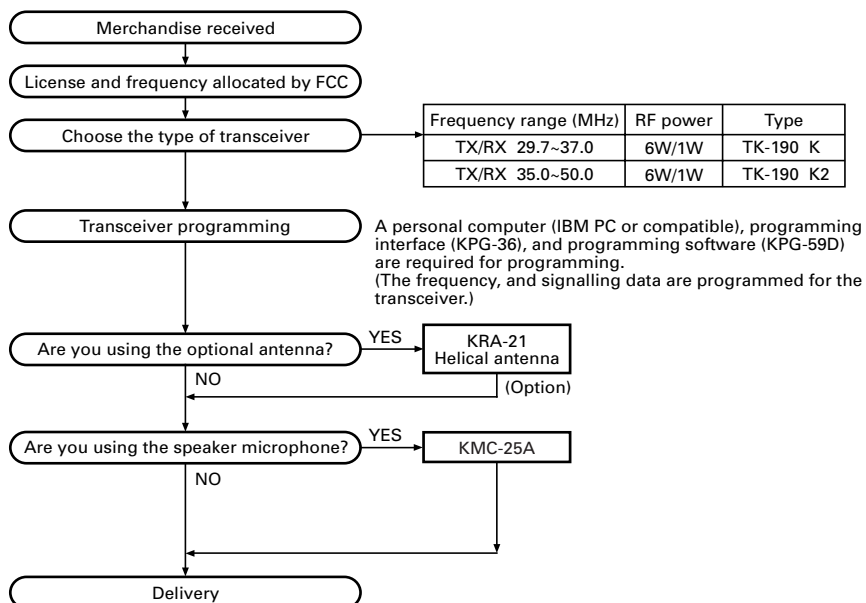

OPERATING FEATURES

1. Getting Acquainted

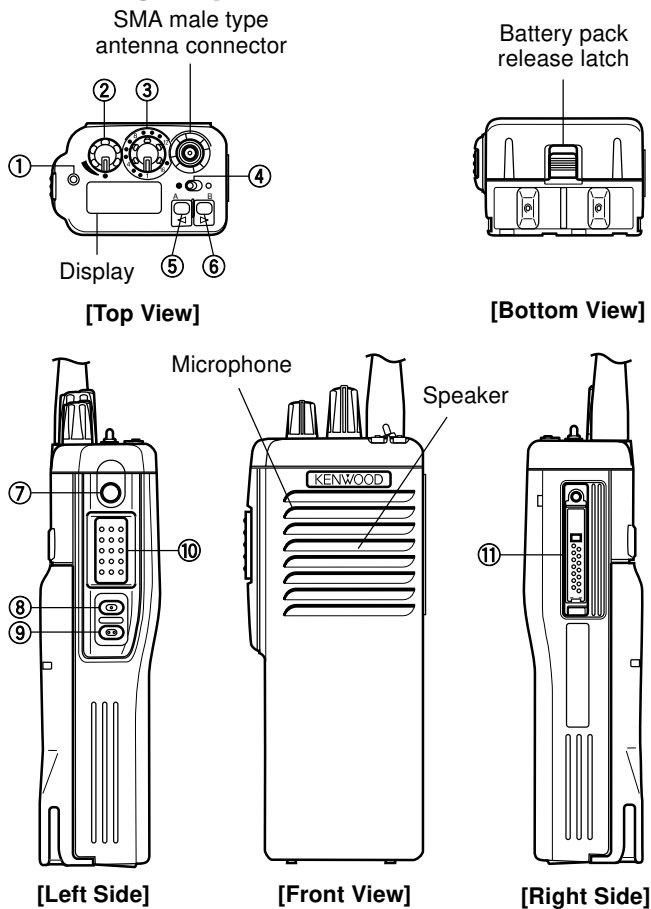

- ① **TX/ BUSY/ CALL/ Battery low LED**
Lights red while transmitting. Lights green while receiving. Lights orange while receiving a 2-Tone/ DTMF call. Flashes red when the battery power is low while transmitting; replace or recharge the battery.
Note: This LED can be disabled by your dealer.
- ② **Power switch/ Volume control**
Turn clockwise to switch the transceiver ON. Turn counterclockwise until a click sounds, to switch the transceiver OFF. Rotate to adjust the volume level. Clockwise increases the volume and counterclockwise decreases it.
Note: Your dealer can set a minimum volume level for the Volume control.
- ③ **Channel selector**
Rotate to select a channel. Clockwise increases the channel number and counterclockwise decreases it.
- ④ **Toggle switch**
Switch the toggle position to the right (○) to activate its programmable function and to the left (●) to deactivate it. The default function of this switch is "No Function".
- ⑤ **Top 1**
Press this PF (programmable function) key to activate its programmable function. The default function of this key is "No Function".

■ Display



Icon	Description
	Displays the operating channel number or name, "UNPROG" (when no channel data is programmed on the transceiver), the OST code or name (in OST Select mode), "SCAN" (while scanning), the squelch level (when adjusting the squelch), the scrambler code (in Scrambler Code Select mode), and "CALL" (when receiving a 2-Tone or DTMF call).
	Displays the operating channel number (if programmed by your dealer), P (Priority), tA (Talk Around), and HC (Home Channel), depending on the function being used.
A	Appears when the selected channel is included in the scan sequence.
SCN	Appears while scanning.
MON	Appears while monitoring a channel.
LO	Appears when using low power on the current channel.
OPT	Appears when Operator Selectable Tone is enabled.
AUX	Flashes when the optional scrambler board is installed and enabled. Appears when AUX is turned ON.

- ⑥ **Top 2**
Press this PF (programmable function) key to activate its programmable function. The default function of this key is "No Function".
- ⑦ **Orange**
Press this PF (programmable function) key to activate its programmable function. The default function of this key is "No Function".
- ⑧ **Side 1**
Press this PF (programmable function) key to activate its programmable function. The default function of this key is "Monitor". Also used as an "up" key for various functions.
- ⑨ **Side 2**
Press this PF (programmable function) key to activate its programmable function. The default function of this key is "Lamp". Also used as a "down" key for various functions.
- ⑩ **PTT (Push-To-Talk) switch**
Press and hold this switch, then speak into the microphone to call a station.
- ⑪ **Universal connector**
Connect the optional KMC-25 speaker/ microphone here. When the KMC-25 speaker/ microphone is not connected, cover the connector with the supplied universal connector cap.

OPERATING FEATURES

2. Scan Operating

2-1. Scan Start Condition

Two or more non-priority channels must be added to all channels that can be scanned. The transceiver must be in normal receive mode (PTT off).

When you activate the key or the toggle switch (to right position) programmed to the scan function, the scan starts. The scan icon "SCN" lights and "SCAN" or revert channel (programmable) is indicated on 7-digit alphanumeric display.

2-2. Scan Stop Condition

The scan stops temporarily if the following conditions are satisfied.

- 1) A carrier is detected, then signalling matches on channel for which receive the signalling is set by the programming software.
- 2) A carrier is detected on the channel for which receiving signalling is not set by the programming software or when the monitor (signalling cancel) function is activated.

2-3. Scan Channel Types

- 1) Priority channel is the most important channel for the scan, and always detects a signal during scan and when the scan stops temporarily.
- 2) Non-priority channels detects a signal during scan. For the channels that can be selected with the channel selector when the scan does not occur, adds an indicator "A" lights.

2-4. Priority Channel Setting

Priority channel can be set as follows with the programming software (KPG-59D).

- 1) Specify priority channel as fixed priority channel.
- 2) Make selected channels, priority channels.

2-5. Scan Type According to the Priority Channel

- 1) When no priority channels are set : Only the non-priority channels are scanned.
If a non-priority channel stops temporarily.
- 2) When one priority channel is set : Either priority channel is scanned.
If a non-priority channel stops temporarily, a priority channel signal is detected at certain intervals.
If a priority channel stops temporarily, it stops until there is no signal on the priority channel.

2-6. Revert Channel

The revert channel is used to transmit during scanning and set by the programming software (KPG-59D).

- 1) Last called channel
The transceiver reverts to the last called channel during the scan.
- 2) Last used channel
The transceiver reverts to the last used (transmitted) channel during scan. "Last used" revert channel includes talkback function.
- 3) Selected with talkback
The transceiver reverts to the channel before scanning or the channel that you changed during scan.

- 4) Selected channel

The transceiver reverts to the channel before scanning or the channel that you changed during scan.

- 5) Priority with talkback

The transceiver reverts to the priority channel.

If you press PTT during a resume timer (dropout delay time, TX dwell time) or calling, you can transmit on current channel to answer to the call however revert channel is set to priority channel.

After resume time, scan re-starts and transmission channel is return to priority channel.

- 6) Priority

The transceiver reverts to the priority channel.

2-7. Scan End

When you press the key once again, or the toggle switch (to left position) programmed to the scan function during scan mode, the scan ends.

The scan icon "SCN" and "SCAN" or revert channel (programmable) display goes off.

2-8. Temporarily Delete/Add

It is possible to delete or add channel temporarily during scan. When scan stops on unnecessary channel for example by interference of the other party, activate the delete/add function (for example press the key), then that channel is deleted temporarily and scan re-start immediately.

When you would like to add the deleted channel temporarily to scan sequence, select the desired (deleted) channel during scan, activate the delete/add function (for example press the key) before scan re-start.

That channel is added temporarily to scan sequence. The temporary deleted or added channels are returns to pre-set delete/add, when the transceiver exits from scan mode.

OPERATING FEATURES

3. Optional Features

You can use these features using the programming software (KPG-59D).

3-1. Beep Tones

The beep tones (power on tone, control tone, warning tone, alert tone) are individually programmable to the fixed level 0 to 31 or follow the mechanical volume position.

3-2. Minimum Volume

The minimum volume is programmable (0 to 31). The transceiver remains the minimum volume level however the mechanical volume position is set to zero.

3-3. BCL (Busy Channel Lockout) Override

You can transmit in spite of Busy Channel Lockout situation. For example : To make an emergency voice call.

To transmit under busy channel lockout situation, press PTT once more within approx. 500ms after the PTT release.

3-4. Selective Call Alert LED

You can select whether or not the LED on the transceiver flashes in an orange color when Selective call was occurred.

3-5. Battery Warning

This transceiver has battery warning feature. If the low voltage is detected during transmission, the transceiver warns it by flashing red "LED".

Then more low voltage is detected during transmission, the transceiver stops transmission and warns it by flashing red "LED" and beep.

Please notice "standard" for the battery exchange, charging time by flashing red LED and beep.

3-6. Busy LED

You can program the enable or disable the busy "LED" function when a carrier is detected. "Disable" saves battery life.

3-7. TX LED

You can program the enable or disable the transmission "LED" function.

3-8. 2-Digit 7-Segment Display

You can use 2-digit 7-segment the display to display the channel number or group number. It is useful when the main (7-digit 13-segment) display indicates channel name.

3-9. Invert Display

Main (7-digit 13-segment) display and sub (2-digit 7-segment) display can be programmed to invert display.

It is easy to read the display when the operator suspended the transceiver on a waste belt. The operator also can change the display between normal and invert using key. Refer the invert display function of key function.

3-10. Emergency Channel Display

The transceiver can be programmed to display "EMERGENCY" channel name when it is in emergency mode.

If you set to "off" by KPG-59D the transceiver shows selected group/channel/status before entering to the emergency mode however the transceiver is in an emergency mode.

3-11. Clear to Transpond

The transceiver waits the transpond of 2-Tone/DTMF if channel is busy until channel open. This feature prevents the interference to other party.

3-12. External Speaker

It can be selected if the receive sound is made by SP-Mic SP or the main body SP at a SP-Mic mount.

3-13. Mode (Enable/Disable)

The transceiver has many special modes mainly for maintenance.

- Panel Test mode
- Clone mode
- Main programming mode

It is possible to set enable/disable for each mode. We recommend to set these mode to Disable after set up to save contents.

3-14. ID

The transceiver is capable to have ID. The format is DTMF. The timing that the transceiver sends ID is programmable.

Begin of TX : Connect ID is send on beginning of transmission.

End of TX : Disconnect ID is send on end of transmission.

Both : Connect ID is send on beginning of transmission and disconnect ID is send on end of transmission.

Off : Sending ID function is disabled.

There is also "PTT ID" setting for each channel. Refer "PTT ID" of channel feature.

3-15. OST (Operator Selectable Tone)

The transceiver is capable to have "OST" function and 16 tone pair (QT/DQT) with max 7-digit name for each tone pair.

• "OST" Back Up

The transceiver is programmable the selected "OST" code is memorized or not. If you set to Disable (no memorized), the "OST" function always starts at "off".

3-16. Data Password (Keypad Model Only)

The data password prevents unauthorized reading of the programmed transceiver data by FPU. Enter pre-programmed password in FPU reading process.

OPERATING FEATURES

3-17. "TOT" (Time-Out Timer)

The transceiver has the "TOT". This parameter selects the period of time users can continuously transmit.

When the selected period passes, the transceiver generates a warning tone and stops the transmission.

3-18. "TOT" Pre-Alert

The transceiver has "TOT" pre-alert timer. This parameter selects the time at which the transceiver generates "TOT" pre-alert tone before "TOT" is expired.

"TOT" will be expired when the selected time passes from a TOT pre-alert tone.

3-19. "TOT" Re-Key Time

The transceiver has "TOT" re-key timer. This timer is the time you can not transmit after "TOT" exceeded. After "TOT" re-key time expired you can transmit again.

3-20. "TOT" Reset Time

The transceiver has "TOT" reset timer. This timer is the minimum wait time allowed during a transmission that will reset the "TOT" count.

"TOT" reset time causes the "TOT" to continue even after PTT is released unless the "TOT" reset timer has expired.

3-21. Signalling

Signalling "AND/OR" sets the audio unmute condition for any channel programmed with the option signalling (2-Tone/DTMF).

AND : "AND" requires both the valid option signalling and the programmed QT/DQT to be received for audio to unmute (and initiate an option signalling decode alert).

OR : "OR" requires either the valid option signalling or the programmed QT/DQT to be received for audio to unmute (an option signalling decode alert is only initiated if the proper option signalling is decoded).

3-22. Noise Canceling Microphone

Reduce the background noise.

4. Channel Features

You can use these features using the programming software (KPG-59D).

4-1. Alphanumeric Display (Channel Name)

The programming software (KPG-59D) enables you to set the alphanumeric display for channel name. The total text size of channel name are 7-digits.

For example, If you set 2-digits for group name, then you can use 5-digits for channel name. The characters can be used as shown in Figure 1.



Fig. 1

4-2. Option Signalling

The transceiver is programmable to the option signalling (2-Tone decode program 1, 2-Tone decode program 2, 2-Tone decode program 3, DTMF decode) to each channel. It is useful to receive an individual call.

Receive format is selectable "AND" or "OR" with QT/DQT. The radio response of option signalling is programmable call Alert and "Transpond" for each option signalling (2-Tone decode program 1, 2-Tone decode program 2, 2-Tone decode program 3, DTMF).

4-3. PTT ID

PTT ID provides a DTMF ANI to be sent with every time PTT (connect ID at beginning of transmission, disconnect ID at end of transmission, or both).

You can program PTT ID "on" or "off" for each channel. The contents of ID are programmed for each transceiver.

4-4. Busy Channel Lockout

Transmission is inhibited when the channel is busy. It is able to set this feature "Yes" or "No" for each channel.

4-5. Beat Shift

This is the feature that the microprocessor shifts its system clock frequency slightly to prevent the receive interference. This transceiver can program this feature "Yes" or "No" for each channel.

OPERATING FEATURES

4-6. TX Power

You can set the transmission power "High" or "Low" for each channel. The each power setting is tuned at factory.

However, you can re-tune the power, using PC Tuning Mode of KPG-59D.

4-7. Scan Delete/Add

Scanning "delete/add" is programmable for each channel. Set the currently selected channel required to include in the scan sequence to "add".

The operator can change the "delete/add" information using the key programmed to "delete/add" function.

5. Key Functions

Programmable Auxiliary Functions

The toggle switch, PF keys, and Speaker/ Microphone keys can be programmed with the auxiliary functions listed below:

Function Name	Toggle Switch	PF Keys	Speaker/ Microphone Keys
Aux ¹	✓	✓	✓
Channel Down		✓	✓
Channel Name		✓	✓
Channel Up		✓	✓
Delete/Add		✓	✓
Emergency Call ²		✓	✓
Home Channel		✓	✓
Invert Display	✓	✓	✓
Key Lock	✓	✓	✓
Lamp		✓	✓
Low Power	✓	✓	✓
Monitor	✓	✓	✓
Monitor Momentary		✓	✓
No Function	✓	✓	✓
Operator Selectable Tone		✓	✓
Scan	✓	✓	✓
Scrambler ³	✓	✓	✓
Shift	✓	✓	
SP Attenuation			✓
Squelch Level		✓	✓
Squelch Momentary		✓	✓
Squelch OFF	✓	✓	✓
Talk Around	✓	✓	✓

1 This function can be selected only when the scrambler board has not been installed.

2 This function can be selected only when the ANI board has been installed.

3 This function can be selected only when the scrambler board has been installed.

Note :

- If your dealer programs "Shift" onto a PF key or the toggle switch, the remaining PF keys can be programmed with an additional function. To use the additional functions, you must first press and hold the Shift key, then press the function key you desire. The toggle switch and the key programmed with "Shift" cannot be programmed with an additional function.
- When the same auxiliary function is programmed onto both a PF key and the toggle switch, an error will occur on the PF key and it cannot be used.

Fig. 2 Programmable functions

OPERATING FEATURES

You can use these features, using the programming software (KPG-59D). Selector function is selectable channel select or group select.

The functions for Toggle switch are listed page 7 (Fig. 2). Right position is active for programmed function on toggle switch except "group select".

The functions for the top key are listed page 7 (Fig.2). Hold action and shift action are programmable.

The functions for side key are listed page 7 (Fig.2). Hold action and shift action are programmable.

The functions for microphone key are listed page 7 (Fig.2). Hold action is programmable.

5-1. No Function

Sounds error operation beep, and no action will occur. Use this function when the transceiver is required to be more simple operated.

5-2. AUX.

This function can be programmed when the voice scrambler board is not installed.

If this key is pressed, "AUX" icon lights on the LCD and "CLR/C" port which is inside of the transceiver turns to the high level. If pressed again, the "AUX" icon goes off and the "CLR/C" ports turns to the lower level.

5-3. Channel Down

If this key is pressed once, the channel number decreases by one step. If this key is hold down, the channel number decreases continuously.

5-4. Channel Up

If this key is pressed once, the channel number increases by one step. If this key is hold down, channel number increases continuously.

5-5. Channel Name

This key switches the LCD display between the current channel number and programmed channel name.

5-6. Delete/Add

This key switches the currently displayed channel between "Delete" and "Add".

The "Add" channel contained in the scan sequence, and "Delete" channel is not contained. In the scan mode, this key switches the channel delete or add temporarily.

5-7. Home Channel

Press this key once, the channel switches to the pre-programmed home channel. Press this key again, the channel goes back to the previous channel.

5-8. Invert Display

Press this key once, the displayed the channel number or channel name are inverted. Press this key again, the display returns to the normal.

For the operator who does not change the display and needs "Invert" only, refer "Invert Display" setting of optional feature.

5-9. Key Lock

Pressing this key causes the transceiver to accept an entry of only the [Shift], [KeyLock], [PTT], [Emergency] keys, [Selector switch], [Volume], [Toggle], [Lamp], [Moni], [Moni momentary], [SQ off], [SQ momentary] and [SP Attenuation]

"Lock" is used to prevent users from unexceptable key press which might cause a transceiver malfunction. The display does not change while the key is being locked.

Pressing Key Lock again cancels the key lock. Key locked transceiver can still receive. Pressing this key while scanning, keys are locked but a scanning continues.

5-10. Lamp

Press this key, the transceiver illuminates the display and back lit approximate 5 seconds. Press this key again, the transceiver stops the illuminating.

Pressing any key except the LAMP key while the illuminated restarts the 5 second timer.

5-11. Low Power

Press this key, the transmission power of all channel changes to Low. Press this key again, the transmission power returns to programmed value.

5-12. Monitor

Monitor the channel before a transmission.

Press this key once, "MON" appears and unmutes speaker if a carrier is present, regardless of the specified signalling (including option signalling). Press this key again, "MON" disappears and mutes speaker.

Press this key after the Option Signalling is matched, the Option Signaling is reset. DBD (Dead Beat Disable) mode is not reset by this operation.

5-13. Monitor Momentary

While pressing this key, the monitor function (refer 5-12) is activated. Release this key, the monitor function is deactivated.

5-14. Operator Selectable Tone

This key switches the pre-set decode QT/DQT and encode QT/DQT to OST (Operator Selectable Tone) tone pair.

Press this key, the transceiver enters to OST select mode. In this mode, the display shows "OFF" and the operator can select one of the OST tone pair using the Side 1/Side 2 key. The display shows "TONE **" and tone pair No. ** is selected or OST name.

Press OST key again, the transceiver exits from the OST select mode, and returns to the channel mode with "OPT" icon. "OPT" icon means that the OST tone pair is selected. OST tone pair number or OFF can be memorized for each channel.

16 kinds of tone pair for OST can be programmed by KPG-59D. OST is useful to access the repeater with same radio frequency and different tone (QT/DQT).

OPERATING FEATURES

5-15. Scan

Press this key starts scanning. Pressing this key stops scanning.

5-16. Shift

This key activates "Shift + [Key]" function. It is useful when the numbers or more of the functions are necessary.

5-17. Squelch Level

The preset squelch level is varied in user mode (0 to 15). Press the key programmed to "squelch level", the transceiver enters to "squelch level adjust mode".

The squelch level can be adjusted by Side 1/Side 2. Press the key programmed to "squelch level" again, the adjusted level is memorized and returns to the normal user mode.

5-18. Squelch Momentary

While pressing this key, the transceiver unmutes speaker regardless of an existence of a carrier and "MON" appears and busy "LED" lights on.

Release this key, the transceiver mutes the speaker and "MON" disappears and busy "LED" lights off.

5-19. Squelch Off

Press this key, the transceiver unmutes speaker regardless of the existence of a carrier and "MON" appears and busy "LED" lights.

Press this key again, the transceiver mutes the speaker and "MON" disappears and busy "LED" lights off.

5-20. Talk Around

Press this key, the transceiver uses the receive frequency and the tone for transmission.

The operator can call the other party directory (without repeater). Press this key again, the talk around function goes off.

5-21. Emergency Call

Press and hold this key, the transceiver enters to an emergency mode. In this mode, the channel is switched to the programmed emergency channel automatically and starts transmission with an emergency ID code which is programmed to ANI board.

The display depends on "Emergency Channel Display" setting.

5-22. SP MIC Attenuation

Press this key once, the volume level of speaker-microphone is attenuated. Press this key again, the volume level of speaker-microphone returns to the previous level.

6.2-Tone

Built-in 2-Tone decoder (decoder program 1, decoder program 2, decoder program 3) is available for option signalling. It is possible to use individual call or group call.

7. DTMF

Built-in DTMF encoder is available for PTT ID. Built-in DTMF decoder is available for option signalling.

It is possible to use individual call, group call, DBD (Dead Beat Disable).

8. Data Programming (PC Mode)

8-1. Preparation and Connection

The TK-190 transceiver is programmed by using a personal computer, programming interface cable KPG-36, and programming software KPG-59D.

The programming software can be used with an IBM-PC or compatible machine. Figure 3 shows the setup for programming.

8-2. Programming Interface Cable KPG-36 Description

The KPG-36 is required to interface the transceiver with the computer. It has a circuit in its D-sub 25pin connector case that converts RS-232C logic level to TTL level.

KPG-36 is used to connect between transceiver universal connector and RS-232C serial port of computer.

8-3. Programming Software KPG-59D Description

KPG-59D is the programming software for TK-190 supplied on a 3.5" floppy disk. This software runs under MS-DOS version 3.1 or later, and Windows MS-DOS prompt on an IBM-PC or compatible machine.

The data can be input to or read from TK-190 and edited on the screen. The programmed or edited data can be printed out. It is also possible to tune the transceiver.

We recommend that install KPG-59D for example to harddisk first then use it.

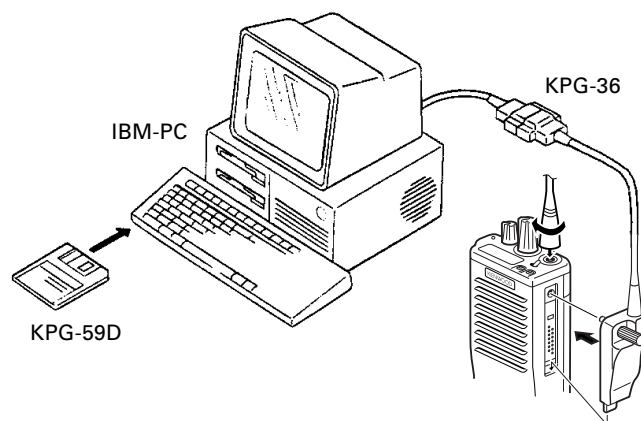
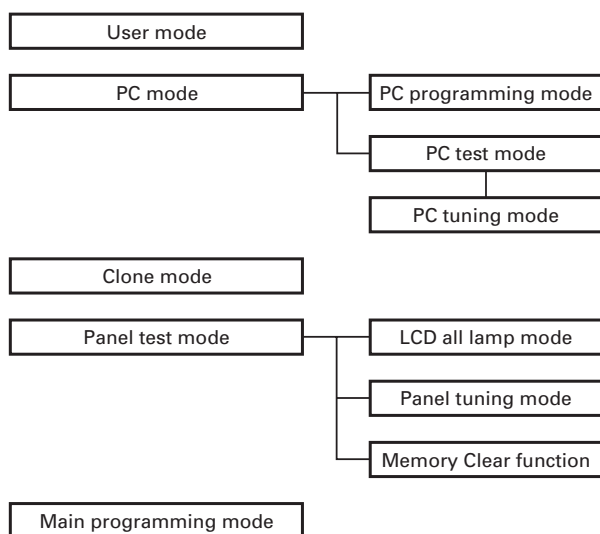

Fig. 3

REALIGNMENT

1. Mode



Mode	Function
User mode	Customer use this mode
PC mode	Communication between the radio and PC (IBM compatible). It requires the KPG-59D
PC programming mode	Frequency, signalling and features write to the radio and read from the radio.
PC test mode	Check the radio using the PC. This feature is included in the FPU.
Panel test mode (Refer to Adjustment)	Dealer use to check the fundamental characteristics.
Main programming mode	Re-write the firmware of the flash ROM.

2. How to Enter Each Mode

Mode	Operation
User mode	Power on
PC mode	Turn on the transceiver. Then, set the transceiver to PC mode from the menu in KPG-59D
Panel test mode	Hold down the [Side 2] key and [PTT], turn the radio power on, and release [PTT] first.
Main programming mode	Held down the [Side 2] key and [PTT], turn the radio power on, and release [Side 2] key first.

3. Clone Mode

1. Turn the master side transceiver power on with the [Side 1] and [Side 2] keys held down. The master side transceiver displays "CLONE".
2. Set the power switch on the slave side transceiver to ON.
3. Connect the cloning interface cable between the master side transceiver (source) and slave side transceiver (clone) as shown in the figure.

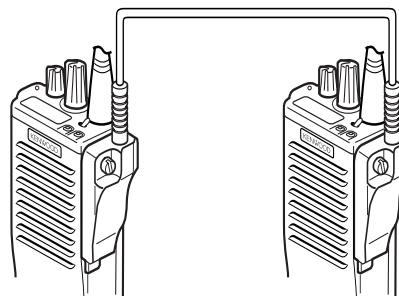

Cloning interface cable
Part No. E30-3325-05

4. Press the [PTT] key on the master side transceiver to start cloning.
5. The red LED on the master side transceiver flashes when cloning starts and an "END" message appears when cloning ends.
6. The green LED on the slave side transceiver flashes.
7. When a problem occurs during cloning, an "ERROR" message appears on the master side transceiver.
8. Pressing the [PTT] key sets clone mode again.

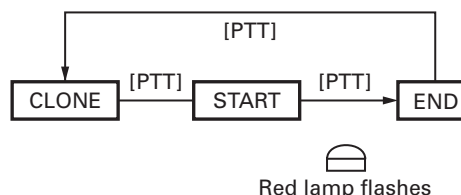

4. Firmware Programming Mode

4-1. Preface

Flash memory is mounted on the transceiver. This allows the transceiver to be upgraded when new features are released in the future. (For details on how to obtain the firmware, contact Customer Service.)

4-2. Connection Procedure

Connect the transceiver to the personal computer (IBM PC or compatible) with the interface cable (KPG-36). (Connection is the same as in the PC Mode.)

REALIGNMENT

4-3. Programming

1. Set the transceiver to Main Programming Mode. (Refer to page 10)
2. Connect the KPG-36 to the transceiver.
3. Start up the programming software (KPG-59D), select "firmware program" in the "Program" item, and press the Return key on the personal computer. This starts up the firmware programmer.
4. The top screen is displayed. Press any key to advance to the next screen.
5. Set the communications speed (normally, 115,200bps) and communications port in the Setup item.
6. Set the firmware to be updated by File select.
7. Held down the [Side 2] and [PTT]. Turn the transceiver power on, and release [Side 2] first. Until the display change to "P R O G•R•A•M•"
8. Check the connection between the transceiver and the personal computer, and make sure that the transceiver is in the Main Program Mode.
9. Press F10 on the personal computer. A window opens on the display to indicate progress of writing. When the transceiver starts to receive data, "PG" is appeared on 2 digit sub display.
10. If writing ends successfully, the red LED on the transceiver lights and the checksum is displayed.
11. If you want to continue programming other transceivers, repeat steps 5 to 8.

Notes :

- To start the Firmware Programmer from KPG-59D, the Fpro path must be set up by KPG-59D setup.
- This mode cannot be entered if the Main Program mode is set to Disable in the Programming software (KPG-59D).

4-4. Function

1. If you press the [Top 2] key while "PROGRAM" is displayed, the checksum is displayed. If you press the [Top 1] key while the checksum is displayed, "PROGRAM" is redisplayed.
2. A transmission speed can be selected by pressing the [Top 1] key while "PROGRAM" is displayed.

19200bps : P R O G R A M•	1dot lights
38400bps : P R O G R A•M•	2dots light
57600bps : P R O G R•A•M•	3dots light
115200bps : P R O G•R•A•M•	4dots light

Note :

Normally, write in the high-speed mode.

5. Panel Test Mode

Setting method refer to ADJUSTMENT.

CIRCUIT DESCRIPTION

1. Overview

The KENWOOD model TK-190 is a VHF/FM hand-held transceiver designed to operate in the frequency range of 29.7 to 37MHz(K), 35.0 to 50.0MHz(K2), the unit consists of a receiver, a transmitter, a phase-locked loop(PLL) frequency synthesizer, power supply circuit, a control unit.

2. Circuit Configuration by Frequency

The receiver is a double-conversion super-heterodyne with a first intermediate frequency (IF) of 128.55MHz and a second IF of 455kHz. Incoming signals from the antenna are mixed with the local signal from the PLL1 to produce the first IF of 128.55MHz.

This is then mixed with the 129.005MHz second local oscillator output to produce the 455kHz second IF. This is detected to give the demodulated signal.

The transmit signal is modulated PLL2-VCO2(129.005MHz) from the microphone. The transmit signal frequency is down-conversion with PLL2 and PLL1. It is then amplified and sent to the antenna.

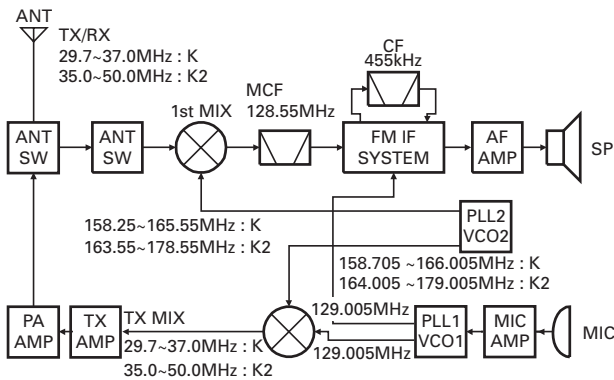

Fig. 1 Frequency configuration

3-3. IF amplifier

The 1st IF signal is amplified (Q302) and fed into IC300 in the FM IC. The IF signal is then mixed with the 2nd local oscillator frequency of 129.005MHz to generate the 2nd IF of 455kHz. The 455kHz signal is then passed through a ceramic filter (CF300) and fed back into IC300 for additional amplification.

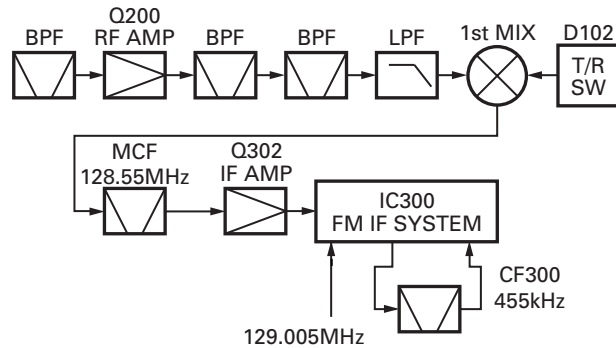

Fig. 2 Receiver section

Item	Rating
Nominal center frequency	128.55MHz
Pass band width	±5~7kHz or more at 3dB
Attenuation band width	±25kHz or less at 3dB
Ripple	1.0dB or less
Insertion loss	6dB or less
Guaranteed attenuation	80dB or more at $f_0 \pm 910\text{kHz}$ 40dB or more within $f_0 \pm 1\text{MHz}$
Terminating impedance	600Ω

Table 1 Crystal filter XF300 (L71-0559-05)

3. Receiver System

3-1. Front-end RF amplifier

The signal are then passed through an antenna matching coil, where the high-frequency components are amplified by a MES FET(Q200). The signals are then fed into band-pass filter that uses varactor diode tuning to reject unwanted signal components, and is fed to the 1st mixer.

3-2. First mixer

The 1st mixer uses the GaAs IC (IC200). The 1st mixer mixes the signal with the 1st local oscillator frequency from the VCO1, and converts to the 1st IF (128.55MHz).

The signal then passes through monolithic crystal filter (XF300) to remove unnecessary nearby frequency components. The signal from the MCF is used as the 1st IF signal.

CIRCUIT DESCRIPTION

3-4. Audio amplifier circuit

• TX-RX unit

The demodulated signal from IC300 goes through IC301, and is amplified by IC601 (2/2), high-pass filtered, low-pass filtered, high-pass filtered, band-eliminate filtered, and de-emphasized by IC607.

The signal then goes through an electronic volume control (IC603), an AF amplifier IC604 (2/2), and an AF switch (Q8 is on and Q7 is on of the control unit), and is routed to audio power amplifier (IC1 of the control unit), where it is amplified and output to the internal speaker.

• Control unit

The audio mute signal (AMP SW) from the microprocessor becomes Low in the standby and Q5, Q6 which are power supply circuit for IC1 turn off. When the audio is output, AMP SW becomes High to turn Q5, Q6 on, and voltage is supplied to power terminal VP of IC1.

Speaker switching is done from IC403 (TX-RX unit) by INT AFC or EXT AFC. First, the logic level at the speakers switching terminal (SSW) on the universal connector is input to the microprocessor (IC406 TX-RX unit). The microprocessor then outputs data to IC403 based on this input.

When there is no SP-MIC installed, this logic level is high. When the INT AFC is high, the EXT AFC goes low, so the AF signal is only input to the amplifier for the internal speaker (INT SP) of IC1. However, when a SP-MIC has been installed, this logic level is low, so the INT AFC goes low and the EXT AFC goes high. So that the AF signal is input only to amplifier for the external speaker (EXT SP) of IC1.

3-5. Squelch circuit

It amplifies the demodulated noise signal from FM IC (IC300) after filtering through BPF circuit. Then, the amplified signal is converted to DC signal by the detection circuit. The converted signal is fed through the microprocessor (IC 406) and the voltage level is detected by ADC (A/D converter) to control the squelch circuit.

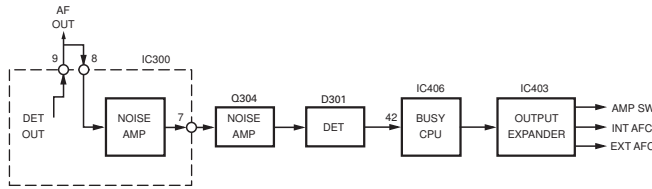

Fig. 4 Squelch circuit

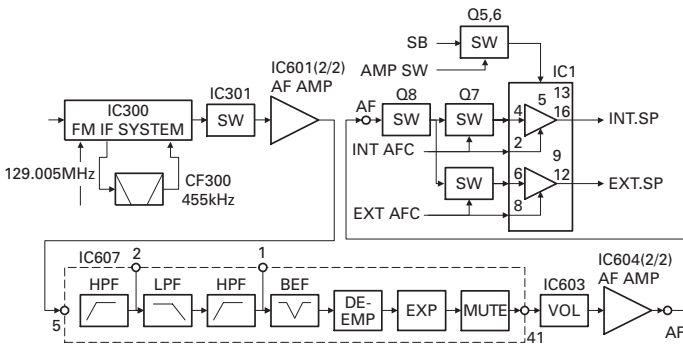

Fig. 3 Audio amplifier circuit

CIRCUIT DESCRIPTION

4. Transmitter System

4-1. Microphone amplifier

The signal from IC3 (control unit) goes through the mute switch (Q403).

When the SP-MIC is not attached, the microphone switching terminal (MSW) on the universal connector becomes High, and mute switch (Q403) is turn on. When the SP-MIC is attached, MSW is connected to GND at inside of SP-MIC. For this reason, Q403 is turned off, the internal microphone is muted, and only the input of the external microphone is supplied to the microphone amplifier of the TX-RX unit.

The signal from microphone passes through the limiter circuit in D601, through the high-pass filter, the ALC circuit, the low-pass filter, the high-pass filter, and pre-emphasis/IDC circuit in IC607. When encoding DTMF, mute switch (Q601) is turned off for muting the microphone input signal.

The signal passes through the D/A converter (IC603) for the maximum deviation adjustment. And enters the summing amplifier consisting of IC605 (1/2), and is mixed with the low speed data from the CPU (IC406).

The output signal from the summing amplifier goes to the VCO2 modulation input.

4-2. Noise cancelling microphone circuit

The two signals from INT MIC (Main & Sub) are input to the positive (+) input (Sub) and to the negative (-) input (Main) of the IC3. If the same signal is input to both Main and Sub, the Main signal is canceled at the output of IC3 (pin 7). In other words, noise words, noise from nearby sources not directly connected the transceiver enters the Main and Sub inputs at the same signal and is therefore canceled out.

When a signal is only input to Main and there is no signal at Sub, the Main signal is output as is, from IC3 (pin 7). In other words, only the voice audio of the operator in extremely close proximity to the Main MIC is input to Main so that the signal is output as is from IC3 (pin 7). Also, when the "N/C" switch is set to "L", transistor Q14 turns off so Sub microphone turns off and operation is the same as above.

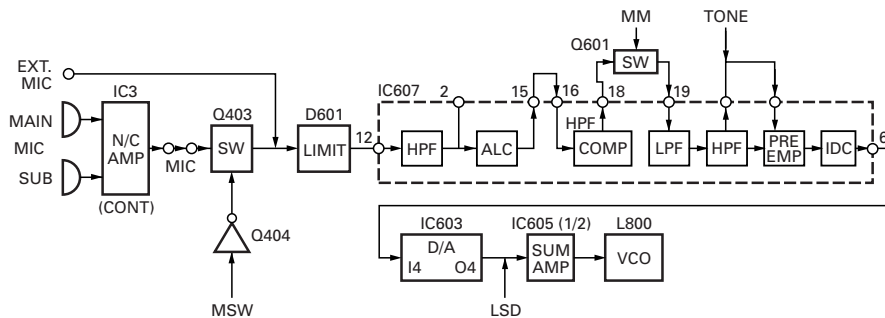

Fig. 5 Microphoen circuit

4-3. Down-mixer

At Q102, a modulated VCO2 signal is mixed with 2nd local oscillator signal, 129.005MHz. The difference of the two signals is used for the transmission signal (29.7 – 37MHz). The output was filtered through a LPF (Low Pass Filter).

4-4. Drive and Final amplifier

The signal from Down-mixer is amplified by the pre drive (Q32) and drive amplifier (Q1) to 500mW. The output of the drive amplifier is amplified by the RF power amplifier (Q1,Q2 in the FINAL unit) to 6W (1W when the power is low).

The RF power amplifier consists of two MOS FET transistor. The output the RF power amplifier is then passed through the transmit-receive (TX-RX) antenna switching (D2 is on) and the harmonic filter (LPF) and applied to the antenna terminal.

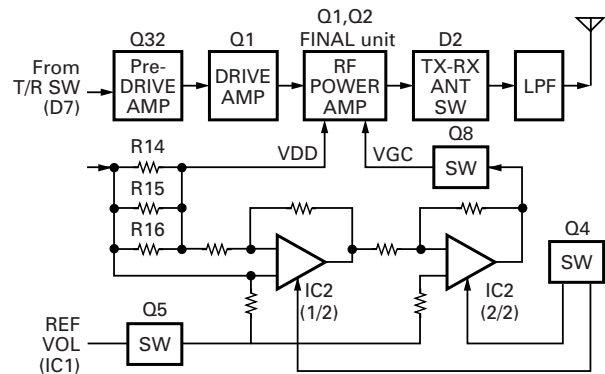

Fig. 6 Drive and final amplifier and APC circuits

CIRCUIT DESCRIPTION

4-5. APC circuit

The APC circuit always monitors the current flowing through the RF power amplifier (Q1, Q2) and keeps a constant current. The voltage drop at R14, R15, and R16 is caused by the current flowing through the RF power amplifier and this voltage is applied to the differential amplifier (IC2 1/2).

IC2 (2/2) compares the output voltage of IC2 (1/2) with the reference voltage from IC1, and the output of IC2 (2/2) controls the VGC of the RF power amplifier to make the both voltages to same voltage.

The change of power high/low is carried out by the change of the reference voltage. Q4, Q5, and Q8 are turned on in transmit and the APC circuit is active. (See Figure 6)

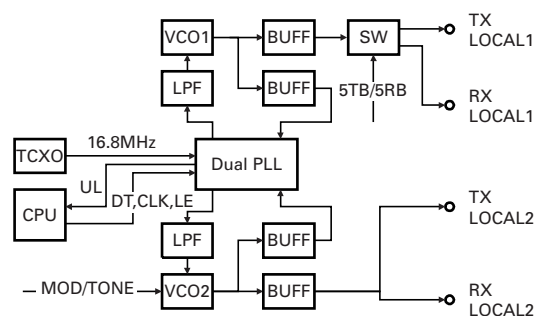

Fig. 7 PLL block diagram

5. PLL Frequency Synthesizer

The frequency synthesizer consists of the VCXO (X1), VCO (L800), PLL IC (IC101) and buffer amplifiers.

The VCXO generates a 16.8MHz reference frequency. The frequency stability is within $\pm 5.0\text{ppm}$ (temperature range of -30 to $+60^\circ\text{C}$).

The output of the VCXO is applied to pin 8 of the PLL IC.

The VCO of TK-190 covers a 7.3MHz frequency spread.

VCO (L800) has 2 internal VCOs. One for the 1st local oscillator (158.25 – 166.005MHz) and another one for the 2nd local oscillator (129.05MHz). Each output is connected to a dual PLL IC (IC101).

VCO1 oscillates at 158.705 – 166.005MHz during transmission and it oscillates at 158.205 – 166.55MHz during reception.

VCO2 oscillates at 129.005MHz during both reception and transmission. However, the oscillated signal is modulated during transmission.

Each PLL circuit has LPFs and buffer amplifiers.

The output of VCO1 goes through the buffer amplifier, then the output is switched either for the 1st local oscillator circuit of the receiver or transmitter.

The output of VCO2 goes through the buffer amplifier. The output is connected to both the receiver and transmitter 2nd local oscillator circuits.

6. Power Supply Circuit

Battery +B is supplied via a 3A fuse from the battery terminal connected to the TX-RX unit. After passing through the power switch power supply (SB) is applied to the two AVR ICs, and AVR circuit.

IC401 supplies 5V (5CM) to the control circuit. IC402 supplies 5V (5C) to the common circuit. AVR circuit (Q400, Q402) supplies voltage to the TX circuit. 5R and 5RB is 5V for reception and output during reception. 5T and 5TB is 5V for transmission and output during transmission.

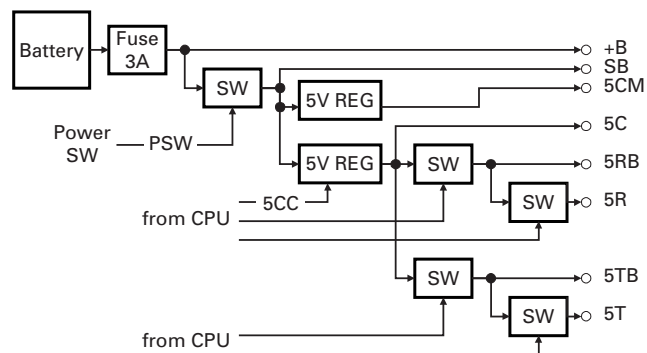

Fig. 8 Power supply circuit

CIRCUIT DESCRIPTION

7. Control Circuit

The control unit circuit consists of microprocessor IC406 and flash memory IC414. It controls the TX-RX unit and transfers data to and from the control unit. The CPU (IC406) mainly performs the following :

- 1) Switching between transmission and reception by PTT signal input.
- 2) Reading channel, frequency, and program data from the memory circuit.
- 3) Sending frequency program data to the PLL.
- 4) Controlling squelch on/off from the squelch circuit.
- 5) Controlling the audio mute circuit by decode data input.
- 6) Transmitting encode data (QT, DQT).
- 7) Sending serial data to output expander (IC400, IC403, IC404 and IC405) to various function in the unit.

7-1. Memory circuit

IC414 has a flash memory with a capacity of 2M bits that contains the transceiver control program for the CPU and data such as transceiver channels and operating features.

This program can be easily written from an external devices. Data, such as DTMF memories and operating status, are programmed into the EEPROM (IC412).

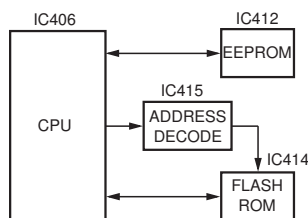

Fig. 9 Memory circuit

7-2. CPU clock

The CPU clock is generated by VCXO (16.8MHz) and it is fed through an inverter, IC416. This clock was divided into a half cycle (1/2 frequency) at the internal CPU. The CPU further divides this clock to utilize it as the various clocks.

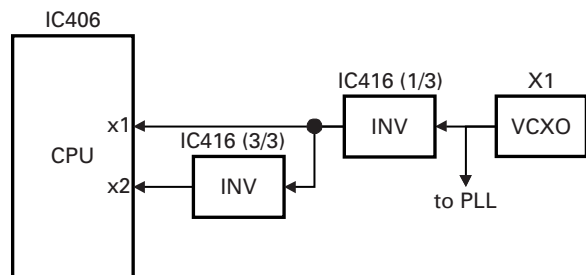

Fig. 10 CPU clock circuit

7-3. Shift register

IC400, 403, 404 and 405 is an interface IC for output port expansion. It is used to expand the CPU (IC406) output ports.

7-4. D/A converter

IC1 and IC603 is used as a conventional semi-fixed-resistor converter. It sets the following :

- 1) RX filter tuning
- 2) Transmission power tuning
- 3) Modulation level tuning
- 4) Audio power tuning

7-5. Key input

KI1 or KI2 becomes HIGH when any key is pressed (or Enable signal on the optional circuit).

When KI1 or KI2 becomes HIGH, KI0 also becomes HIGH to trigger the interrupt to IC406 in order to start the key scan.

When the key scan starts, the output terminals (Q1-Q5) become LOW. Only the key sensing circuit remains HIGH. When a key is pressed, the signal is routed through KI1 or KI2 to the microprocessor. Then, the microprocessor determines which key is pressed using this signals.

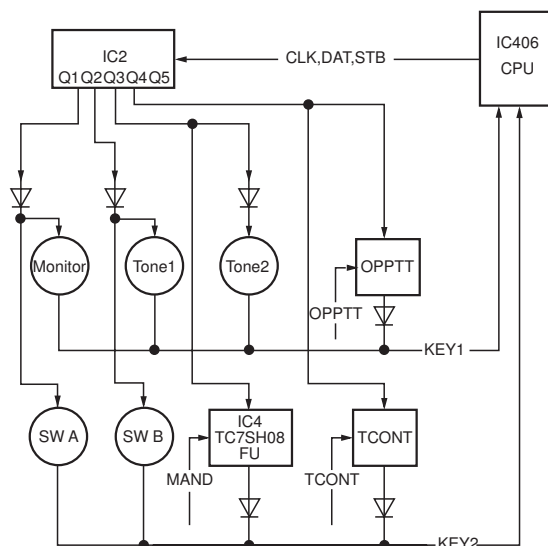

Fig. 11 Key input

CIRCUIT DESCRIPTION

7-6. Low battery warning

The battery voltage is monitored by the microprocessor (IC406). When the battery voltage falls below the voltage set by the Low Battery Warning adjustment, the red LED flashes to notify the operator that it is time to replace the battery. If the battery voltage falls even more (approx. 5.8V), a beep sounds and transmission is stopped.

Low battery warning	Battery condition
The red LED flashes during transmission.	The battery voltage is low, but the transceiver is still usable.
The red LED flashes and continuous beep sounds while PTT pressed.	The battery voltage is low and the transceiver is not usable to make calls.

8. Signalling Circuit

8-1. Encode

The CPU (IC406) transmits the encode data selected by the program.

- **Low-speed data (QT, DQT)**

Low-speed data is output from pin 34 of the CPU. The signal passes through a low-pass filter consisting of IC413 (2/2), and goes to the summing amplifier (IC605 1/2). The signal is mixed with the audio signal and goes to the VCO (L800).

- **High-speed data (DTMF)**

High-speed data is output from pin 35 of the CPU. The signal passes through a low-pass filter consisting of IC413 (1/2), and provides a TX DTMF tone and a RX DTMF tone including a beep tone. The TX DTMF tone is passed to the D/A convertor (IC603) for DTMF deviation adjustment, and then applied to the audio processor (IC607).

The signal is mixed with the audio signal and goes to the VCO. The RX DTMF tone is passed the D/A convertor (IC603) for audio control summing amplifier (IC604 2/2), audio power amplifier and then to the speaker.

8-2. Decode

- **Low-speed data (QT, DQT)**

The demodulated signal from the FM IC (IC300) is amplified by IC601 (2/2) and passes through a low-pass filter (IC602) to remove audio components. The signal is input to pin 28 of the CPU.

The CPU digitizes this signal, performs processing such as DC restoration, and decodes the signal.

- **High-speed data (DTMF)**

The DTMF input signal from the FM IC (IC300) is amplified by IC601 (2/2) and goes to IC600, the DTMF decoder. The decoded information is then processed by the CPU. During transmission and standby, the PD terminal is High. When the line is busy, the PD terminal becomes Low, the power down mode is canceled and decoding is carried out.

- **High-speed data (2 tone)**

The demodulated signal from the FM IC (IC300) is amplified by IC601 (2/2) and passes through an audio processor (IC607) and band-pass filter (IC606) to remove a low-speed data.

The CPU digitizes this signal, performs processing such as DC restoration, and decode the signal.

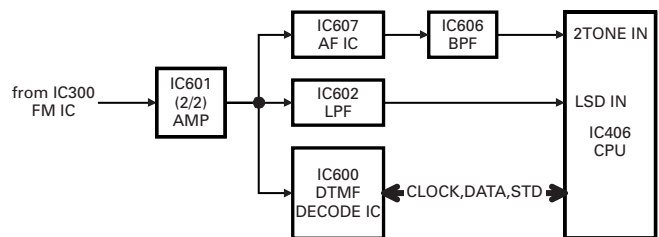

Fig. 13 Decode

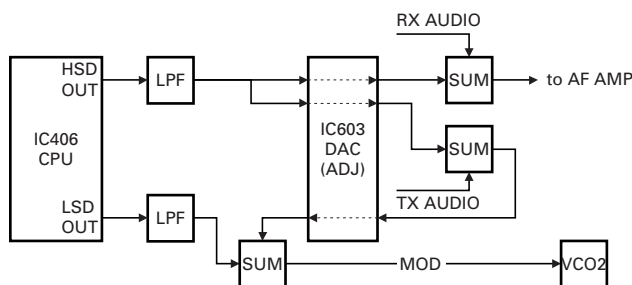

Fig. 12 Encode

CIRCUIT DESCRIPTION

9. Componder circuit

The term compander is a compound of compressor and expander. The compander reduces noise by utilizing a compressor and an expander.

As shown in Fig. 14, the signal input to the compressor is compressed so that the logarithmic ratio is 1/2 with reference to -10dBV, and then output onto the transmission path. The signal is expanded by the expander so that the

logarithmic ratio is 2 with reference to -10dBV. This reduces noise on the transmission path and prevents deterioration of the signal quality due to noise during transmission.

The TK-190 contains IC607 (TC35453F) to perform this operation.

- Pin 16 : Compressor input pin
- Pin 18 : Compressor output pin
- Pin 43 : Expander input pin
- Pin 41 : Expander output pin

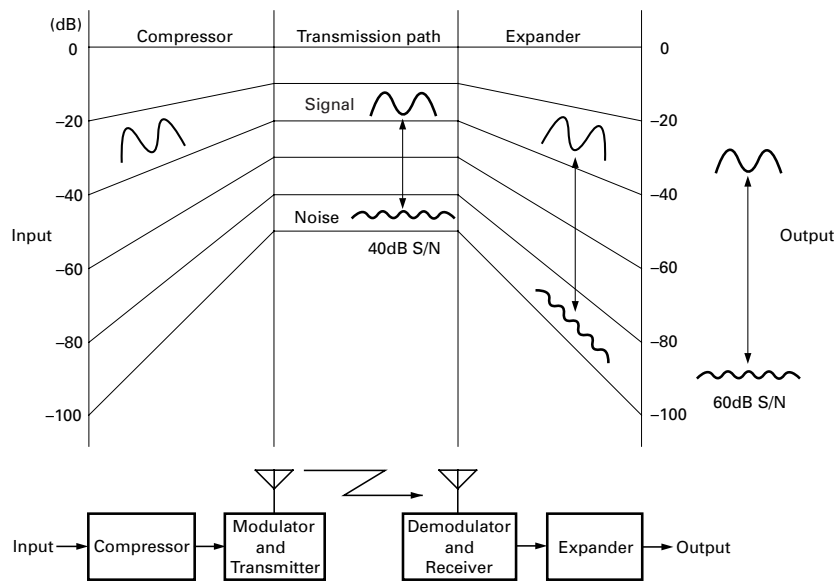

Fig. 14

10. Option Board Terminal

Terminals for mounting the option board are provided at the bottom of the TX-RX unit. The table below shows the correspondence between the board and terminals. Discon-

nect R414 and R665 in TX-RX unit when the voice scrambler board is attached.

Connect the option board to the connection terminals of the TX-RX unit.

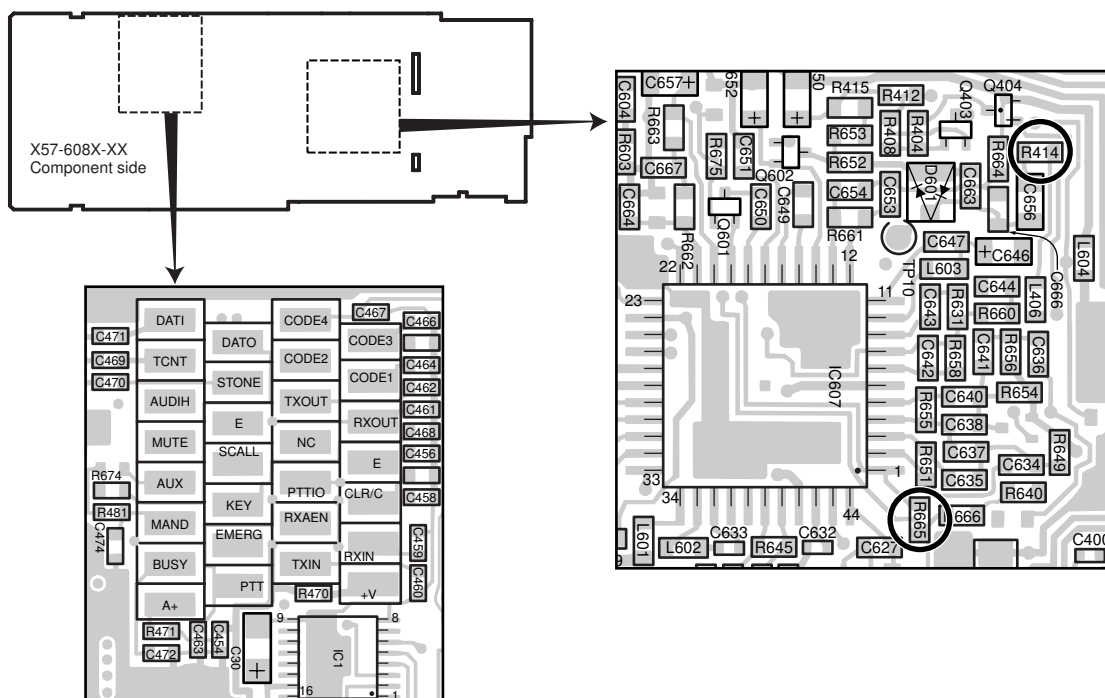

CIRCUIT DESCRIPTION

10-1. Option port 1 (For ANI board etc.)

Port name		Description	Connection	Note
Abbreviation (PCB)	Name			
DATI	Data In	Board data input Transceiver (Receiver demodulation circuit) → ANI board	Connected to the circuit	Reference 1kHz STD Dev → 250~350mVrms
DATO	Data Out	Board data output ANI board → Transceiver (Transmitter modulation circuit)	Connected to the circuit	Reference 1kHz/150mVrms → 2.5~3.5kHz/wide 1.25~1.75kHz/narrow
TCONT	T Control	Audio amplifier power control → Control unit (X53) counter → TX-RX unit (X57) microcomputer	Microcomputer input	L : Audio amp on H : Audio amp off
STONE	Side Tone	Beep during PTT ID	Connected to the circuit	
AUDIH	Audio Inhibit	Microphone muting during PTT ID	Connected to the circuit	
E	Ground	Ground	Ground	
MUTE	Mute	Mutes transceiver receive tone	Connected to the circuit	
SCALL	Selective Call	LED drive port for selective call	Unused, no connection	
AUX	Aux	Emergency Channel request → Control unit (X53) counter → TX-RX unit (X57) microcomputer	Microcomputer input	L : EMG CH request H : No EMG CH request
PTT	PTT	Microcomputer PTT logic → ANI board	Microcomputer output	L : RX, H : TX
MAND	Man Down	Man Down mercury switch input port Transceiver → ANI board	Microphone connector	L : Switch on H : Switch off
EMERG	Emergency	Microcomputer Emergency Channel logic → ANI board	Microcomputer output	L : Emergency operation request H : No emergency operation request
BUSY	Channel Busy	Microcomputer Busy logic → ANI board	Microcomputer output	L : Busy H : Not busy
KEY	(Transmission) Key	Transmission start control GE-Star → Control unit (X53) counter → TX-RX unit (X57) microcomputer	Microcomputer input	L : Transmission request H : No transmission request
A+	Board power supply	Switched B	Power supply	

10-2. Option port 2 (For voice scrambler etc.)

Abbreviation (PCB)	Name	Description	Check mode operation	Note
CODE1	Scramble Code 1	First of four bits of scramble code	Microcomputer output	Board code selection (Logic by binary code)
CODE2	Scramble Code 2	Second of four bits of scramble code		
CODE3	Scramble Code 3	Third of four bits of scramble code		
CODE4	Scramble Code 4	Fourth of four bits of scramble code		
TXOUT	TX Out	Board → Transceiver (Transmitter modulation circuit)	Connected to the circuit	Reference 1kHz/15mVrms → 2.5~3.5kHz/wide 1.25~1.75kHz/narrow
RXOUT	RX Out	Board → Transceiver (Audio amp)	Connected to the circuit	
NC	No Connection	No connection	No connection	
E	Ground	Ground	Ground	
PTTIO		Scramble modulation/demodulation control	Microcomputer output	L : TX, H : RX
CLR/C (AUX)	Clear/Code	Specifies whether to scramble	Microcomputer output	L : Scramble H : Normal
RXAEN		Enables the power save mode of the board	Microcomputer output	L : Power save mode H : Normal
RXIN	RX In	Transceiver (Receiver detection output) → Board	Connected to the circuit	Reference 1kHz STD Dev → 250~350mVrms
TXIN	TX In	Transceiver (Microphone circuit) → Board	Connected to the circuit	
+V	Board power supply	Switched B	Power supply	

SEMICONDUCTOR DATA

1. Microprocessor : 784214GC0618EU (TX-RX Unit IC406)

1-1. Terminal function

Pin No.	Port name	I/O	Function
1	P120/RTP0	O	MODEM FCLR
2	P121/RTP1	O	SB Control
3	P122/RTP2	O	D/A CONVERTER CS
4	P123/RTP3	O	MODEM MSKE (MSK ENABLE)
5	P124/RTP4	O	MODEM DIN (DATA/TX_DATA)
6	P125/RTP5	I	Model select 1
7	P126/RTP6	I	Model select 2
8	P127/RTP7	O	Clock Shift
9	VDD	-	+5V
10	X2	-	X,TAL(12.0MHz)
11	X1	-	
12	VSS	-	GND
13	XT2	-	OPEN
14	XT1	-	GND
15	RESET	-	CPU RESET
16	P00/INTP0	I	UCOM Stop
17	P01/INTP1	I	Modem TRD (TX CLOCK)
18	P02/INTP2/NMI	I	Modem RTM (RX CLOCK)
19	P03/INTP3	I	DTMF Decode STD
20	P04/INTP4	I	Key Interrupt
21	P05/INTP5	I	Power Switch Detect
22	P06/INTP6	I	MIC PTT
23	AVDD	-	+5V
24	AVREF0	-	+5V
25	P10/ANI0	I	Volume level input
26	P11/ANI1	I	SP key 1/2
27	P12/ANI2	I	(Temp)
28	P13/ANI3	I	QT/DQT input
29	P14/ANI4	I	Battery Level input
30	P15/ANI5	I	PLL unlock Detect input
31	P16/ANI6	I	*SQL Level input
32	P17/ANI7	I	*RSSI Level input
33	AVSS	-	GND
34	P130/ANO0	O	LSD (QT/DQT) Output
35	P131/ANO1	O	DTMF/BEEP Output
36	AVREF1	-	+5V
37	P70/RXD2/SI2	O	BATTERY DET SW
38	P71/TXD2/SO2	I	EXT. SP install check (NO : H)
39	P72/ASCK2/SCK2	O	Non Connect
40	P20/RXD1/SI1	I	←FPU
41	P21/TXD1/SO1	O	→FPU
42	P22/ASCK1/SCK1	O	MODEM STB
43	P23/PCL	O	DTMF Clock
44	P24/BUZ	I	DTMF decoder SD
45	P25/SI0	O	LCD CS
46	P26/SO0	O	SHIFT REGISTER 1 STB
47	P27/SCK0	O	SHIFT REGISTER 2 STB
48	P80/A0	-	CAN'T USE.
49	P81/A1	-	FLASH ROM ACCESS PORT.
50	P82/A2	-	
51	P83/A3	-	CAN'T USE.

Pin No.	Port name	I/O	Function
52	P84/A4	-	CAN'T USE.
53	P85/A5	-	
54	P86/A6	-	
55	P87/A7	-	
56	P40/AD0	-	
57	P41/AD1	-	
58	P42/AD2	-	
59	P43/AD3	-	
60	P44/AD4	-	
61	P45/AD5	-	
62	P46/AD6	-	
63	P47/AD7	-	
64	P50/A8	-	
65	P51/A9	-	
66	P52/A10	-	
67	P53/A11	-	
68	P54/A12	-	
69	P55/A13	-	
70	P56/A14	-	
71	P57/A15	-	
72	VSS	-	GND
73	P60/A16	-	CAN'T USE.
74	P61/A17	-	FLASH ROM ACCESS PORT.
75	P62/A18	-	CAN'T USE. FLASH ROM (4Mbit) ACCESS PORT.
76	P63/A19	-	CAN'T USE. OPEN
77	P64/RD	-	CAN'T USE.
78	P65/WR	-	FLASH ROM ACCESS PORT.
79	P66/WAIT	I	TX Inhibit (Radio kill)
80	P67/ASTB	-	CAN'T USE. OPEN
81	VDD	-	+5V
82	P100/TI5/TO5	O	EEPROM CLOCK
83	P101/TI6/TO6	IO	EEPROM DATA
84	P102/TI7/TO7	O	COMMON Clock
85	P103/TI8/TO8	O	COMMON Data
86	P30/TO0	O	Shift Register Out Enable
87	P31/TO1	I	Key Counter return 1
88	P32/TO2	I	Key Counter return 2
89	P33/TI1	I	Self Program Flag (SOFT PULL UP)
90	P34/TI2	O	KEY Counter Enable
91	P35/TI00	I	2Tone Decode Latch
92	P36/TI01	I	Digital SQL
93	P37	O	PLL LE
94	TEST	-	GND
95	P90	I	Rotary SW 1
96	P91	I	Rotary SW 2
97	P92	I	Rotary SW 3
98	P93	I	Rotary SW 4
99	P94	I	Toggle SW Input
100	P95	I	Modem RDT (RX DATA)

SEMICONDUCTOR DATA

2. D/A Converter : M62354GP (TX-RX Unit IC1)

2-1. Terminal connection

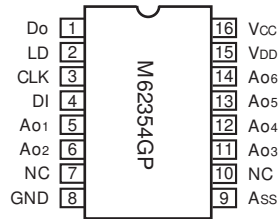

2-2. Block diagram

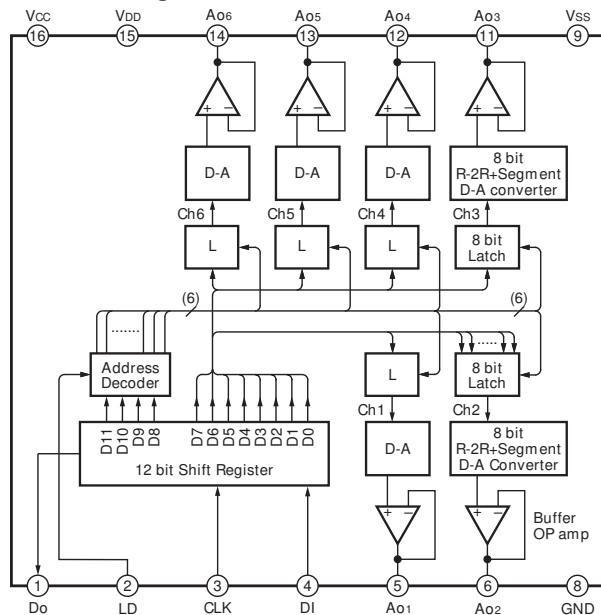

2-3. Terminal function

Pin No.	Symbol	I/O	Function
1	Do	O	12-bit shift register MSB bit data is output.
2	LD	I	When the LD is at the high level, the 12-bit shift register value is loaded to the D/A output register.
3	CLK	I	Shift clock input. With the rise of the shift clock, the input signal from the DI is input to the 12-bit shift register.
4	DI	I	Serial data input. Input serial data 12 bits long.
5,6	AO1, AO2	O	8-bit resolution D/A.
7	NC	-	Not connected.
8	GND	-	GND.
9	Vss	-	Terminal for determining the D/A conversion reference low side point level.
10	NC	-	Not connected.
11~14	AO3~AO6	O	8-bit resolution D/A.
15	VDD	-	Terminal for determining the D/A conversion reference up side point level.
16	Vcc	-	Power supply.

3. LCD Driver : LC75824W (Control unit IC101)

3-1. Block diagram

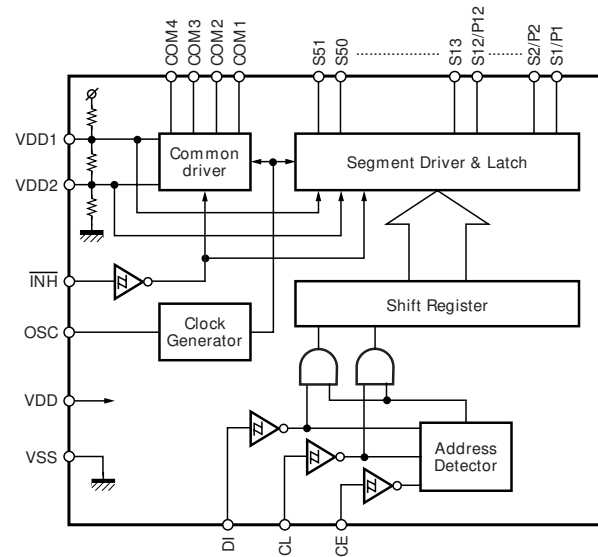

3-2. Terminal function

Pin No.	Name	I/O	Active	Function
1~12	S1/P1~S12/P12	O	-	Segment output for displaying data transferred from serial data.
13~51	S13~S51			
52~55	COM1~COM4	O	-	Common driver output. Frame frequency $f_o = (f_{osc}/512)$ Hz
56	VDD	-	-	
57	VDD1	I	-	Apply 2/3 the LCD drive bias voltage from outside. If 1/2 the bias is applied, connect to VDD2.
58	VDD2	I	-	Apply 1/3 the LCD drive bias voltage from outside. If 1/2 the bias is applied, connect to VDD1.
59	VSS	-	-	
60	OSC	I/O	-	Oscillation terminal.
61	INH	I	L	Force the display to turn off regardless of internal data. Serial data can be input regardless of whether it is "H" or "L".
62	CE	I	H	Chip enable. Serial data transfer terminal. Connected to the microprocessor.
63	CL	I	\uparrow	Synchronizing clock. Serial data transfer terminal. Connected to the microprocessor.
64	DI	I	-	Transfer data. Serial data transfer terminal. Connected to the microprocessor.

4. VCO System : L78-0481-05 (TX-RX Unit L800)

4-1. Circuit diagram

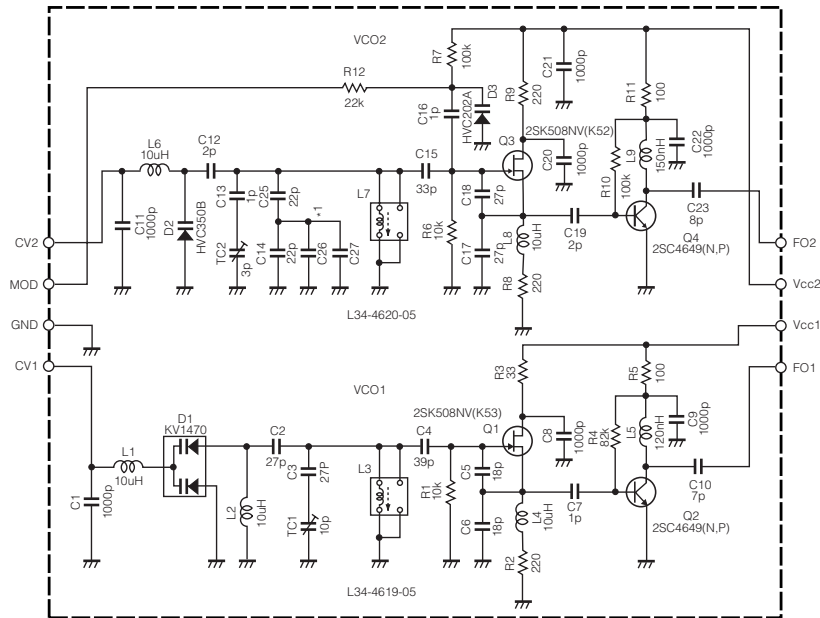

*1 Trimmer capacitor (TC2) decides the oscillation frequency value (oscillation frequency of VC02) of C26 and C27 so that become 127.5~127.7MHz and set to 1/2 position mechanically.
(The value will be change when these ranges of C26 is within 0~6pF and C27 is within 0~1pF).

5. Active DBM : GN2011 (TX-RX Unit IC200)

5-1. Circuit diagram

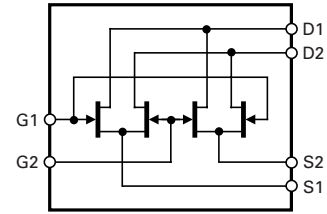

Final Unit (X45-3610-10)

Ref. No.	Use / Function	Operation / Condition
Q1	RF power amplifier	Q1, Q2 Push Pull amplifter
Q2	RF power amplifier	Q1, Q2 Push Pull amplifter

Control Unit (X53-3930-10)

Ref. No.	Use / Function	Operation / Condition
IC1	Audio power amplifier	0.5W/16Ω, BTL amplifier
IC2	Shift register	
IC3	Microphone amplifier	
IC4	Option enable selector	Output by AND logic when key scanned
IC5	Option enable selector	Output by AND logic when key scanned
IC6	Option enable selector	Output by AND logic when key scanned
IC10	Signal logic reversal	Inverter containing
IC101	LCD driver	
Q5	Audio amplifier power supply switch	Operate when output audio signal
Q6	Audio amplifier power supply switch	Operate when output audio signal
Q7	Internal SP output control switch	Operate when output internal SP
Q8	Audio mute switch	Operate when output SP and not operate when mute

Ref. No.	Use / Function	Operation / Condition
Q14	Noise cancel circuit switch	Operates when noise canceled
Q15	External SP output control switch	Operate when output external SP
D2	Low voltage control	Stabilize of audio amplifier power supply voltage
D12	Commutation	
D13	Commutation	
D14	Commutation	
D15	Commutation	
D16	Commutation	
D19	Commutation	
D20	Commutation	
D101	Commutation	
D102	LED for LCD light	
D103	LED for LCD light	
D104	LED fot TX, BUSY turn on	RED, GREEN

DESCRIPTION OF COMPONENTS

TX-RX Unit (X57-608X-XX)

Ref. No.	Use / Function	Operation / Condition	Ref. No.	Use / Function	Operation / Condition
IC1	D/A converter		Q105	RF amplifier	
IC2	APC comparator		Q106	RF amplifier	
IC101	PLL IC containing two circuits		Q200	RF amplifier	Operate when transmitted
IC200	1st mixer IC reception		Q302	IF amplifier	Operate when transmitted
IC300	FM IF SYSTEM IC	2nd mixer, detector, AF amplifier, noise amplifier	Q304	Noise amplifier	Operate when transmitted
IC301	Audio switch	Operate (ON) when received	Q400	DC SWITCH	5T control
IC400	Shift register	Expansion output port	Q401	DC SWITCH	5T control
IC401	5V voltage power supply	5CM	Q402	DC SWITCH	5TB
IC402	5V voltage power supply	5C, 5R	Q403	DC SWITCH	MIC mute
IC403	Shift register	Output expander	Q404	DC SWITCH	MIC SW
IC404	Shift register	Output expander	Q405	DC SWITCH	5T
IC405	Shift register	Output expander	Q406	DC SWITCH	5RB
IC406	Microprocessor		Q407	DC SWITCH	5R
IC409	Reset voltage detection		Q408	DC SWITCH	TX LED (RED) driver
IC412	EEPROM		Q409	DC SWITCH	BUSY LED (GREEN) driver
IC413	LPF filter	For HSD, LSD output	Q410	DC SWITCH	LAMP
IC414	Flash ROM		Q411	Current driver	LAMP :Back light
IC415	Address decode latch	NOR gate	Q413	DC SWITCH	Battery voltage detection
IC416	Clock reverse, buffer amplifier	Inverter	Q414	DC SWITCH	Power supply circuit SW
IC417	Clock reverse	Inverter	Q415	DC SWITCH	SB
IC600	DTMF decode IC		Q416	DC SWITCH	SB
IC601	Buffer amplifier		Q601	MUTE SWITCH	MIC mute
IC602	Active low pass filter	For LSD input	Q602	DC SWITCH	
IC603	D/A converter	Audio adjustment	D1	Constant voltage circuit	
IC604	Mixed, buffer amplifier	For AF, TONE	D2	Antenna switch	
IC606	Mixed amplifier	For MOD	D3	Antenna switch	
IC607	Audio processor		D102	RF switch	
Q1	RF drive amplifier	Operate when transmitted	D201	VARACTOR TUNING	For L201
Q2	RF drive amplifier	Operate when transmitted	D203	VARACTOR TUNING	For L202
Q4	APC circuit movement SW	Operate when transmitted	D207	VARACTOR TUNING	For L206
Q5	APC reference voltage SW	Operate when transmitted	D301	AM detector	Noise squelch
Q7	ANT_SWcircuit control SW	Operate when transmitted	D400	Reverse connect prevention	
Q8	Transmission power control voltage SW	Operate when transmitted	D401	Over voltage protection	
Q32	RF pre-drive amplifier	Operate when transmitted	D402	Surge voltage protecton	
Q101	Ripple filter		D403	Surge voltage protecton	
Q102	Transmission mixer	Operate when transmitted	D404	Commutation	
Q103	RF amplifier		D405	Commutation	
Q104	RF amplifier		D409	Constant voltage circuit	
			D601	Voltage clamp	

PARTS LIST

* New Parts. Δ indicates safety critical components.

Parts without **Parts No.** are not supplied.

Les articles non mentionnés dans le **Parts No.** ne sont pas fournis.

Teile ohne **Parts No.** werden nicht geliefert.

L : Scandinavia

Y : PX (Far East, Hawaii)

Y : AAFES (Europe)

K : USA

T : England

X : Australia

P : Canada

E : Europe

M : Other Areas

TK-190

FINAL UNIT (X45-3610-10)

CONTROL UNIT (X53-3930-10)

Ref. No.	Address	New parts	Parts No.	Description	Destination
TK-190					
1	1A		A02-2139-63	CABINET ASSY	
2	3A	*	A10-4015-21	CHASSIS	
3	2B		A22-2501-25	SUB PANEL ASSY	
4	2B		A62-0537-53	PANEL ASSY	
5	1C		B03-0594-04	DRESSING PLATE ACSY	
6	1C		B09-0363-03	CAP (UNIVERSAL) ACSY	
7	1B		B11-1183-14	REFLECTOR (LCD)	
8	1B		B38-0786-05	LCD	
9	1A		B42-3394-14	STANDARD LABEL	
11	1A		B43-1111-14	BADGE (KENWOOD)	
12	1D		B46-0470-00	WARRANTY CARD	
13	1D	*	B62-1175-00	INSTRUCTION MANUAL	
15	1D		D32-0421-24	STOPPER ACSY	
16	2A		E23-1102-14	TERMINAL	
17	2B	*	E23-1162-04	TERMINAL (X53 D/6)	
18	3A	*	E23-1163-04	RELAY TERMINAL	
20	1B		E29-1165-05	INTER CONNECTOR(LCD)	
21	2A		E37-0682-05	FLAT CABLE (TX/RX-CONT)	
22	1B		E37-0684-05	LEAD WIRE WITH CONNECTOR(SP)	
23	1B		E37-0692-05	PROCESSED LEAD WIRE(TOGGLE SW)	
24	2B	*	E37-0722-05	LEAD WIRE WITH CONNECTOR	
25	3B	*	E58-0440-05	UNIVERSAL CONNECTOR	
27	2A	*	E72-0411-04	TERMINAL BLOCK	
28	2A	*	F12-0453-14	CONDUCTIVE SHEET	
29	2A		G01-0891-04	COIL SPRING (BATT RELEASE)	
-	-		G11-2554-04	SHEET (KEY TOP)	
-	-		G11-2555-04	SHEET (TOGGLE)	
32	2A		G11-2649-04	SHEET (X53)	
33	3A	*	G13-1800-04	CUSHION	
34	2B		G53-0822-04	PACKING(CHASSIS)	
35	1B		G53-0823-04	PACKING(SPEAKER)	
36	1A		G53-0874-03	PACKING(RING)	
37	3A	*	G53-1511-04	PACKING(BATT +)	
38	3A	*	G53-1518-04	PACKING(BATT TERMINAL)	
39	2C		H12-3018-02	PACKING FIXTURE	
40	1C		H25-0029-04	PROTECTION BAG (60/110)	
42	3D	*	H52-1480-02	ITEM CARTON CASE	
43	2A		J19-5330-14	HOLDER(BATT RELEASE)	
44	1A		J21-8326-14	HARDWARE FIXTURE(SIDE KEY)	
45	1B		J21-8328-14	HARDWARE FIXTURE(LCD)	
47	2A		J21-8329-14	HARDWARE FIXTURE(CONT UNIT)	
48	2B		J21-8343-14	HARDWARE FIXTURE	
49	1C		J29-0652-25	BELT HOOK ACSY	
50	1A		J82-0047-05	FPC (SIDE KEY)	
52	2B		J82-0049-15	FPC (VOL-CH SW)	
53	3A		J82-0052-15	FPC (UNIVERSAL CONNECTOR)	
54	2B	*	J99-0346-24	ADHESIVE TAPE(TOGGLE SW)	
55	2B		K29-5172-32	KEY TOP (TOP)	
57	1A		K29-5173-13	KEY TOP (SIDE KEY)	
58	2A		K29-5220-13	LEVER KNOB (BATT RELEASE)	
59	2B		K29-5282-04	KNOB ASSY (CH SW)	
60	2B		K29-5283-04	KNOB ASSY (VOL)	
61	1A	*	K29-5441-04	KNOB ASSY (PTT)	
A	2B		N14-0594-04	CIRCULAR NUT (ANT CONNECTOR)	

Ref. No.	Address	New parts	Parts No.	Description	Destination
B	2B		N14-0578-04	CIRCULAR NUT (VOL/CH SW)	
C	3A		N30-2608-45	PAN HEAD MACHINE SCREW	
E	1A		N78-2030-46	PAN HEAD TAPTITE SCREW	
F	3A		N79-2035-46	PAN HEAD TAPTITE SCREW	
G	2A		N83-2004-46	PAN HEAD TAPTITE SCREW	
H	2A		N83-2005-45	PAN HEAD TAPTITE SCREW	
65	1C		N99-2004-05	SCREW SET	
66	2B	*	R31-0638-05	VARIABLE RESISTOR	
67	2B		S60-0408-15	ROTARY SWITCH	
68	1B		S72-0402-05	TOGGLE SWITCH	
69	1B		T07-0349-05	SPEAKER	
70	2A		T91-0575-05	MIC ELEMENT	
FINAL UNIT (X45-3610-10)					
C2			CC73FCH1H221J	CHIP C 220PF J	
C3,4			CK73FB1H103K	CHIP C 0.010UF K	
C5,6			CK73GB1H103K	CHIP C 0.010UF K	
C8,9			CK73FB1H103K	CHIP C 0.010UF K	
C10			CK73GB1H103K	CHIP C 0.010UF K	
L1,2		*	L39-1439-05	TOROIDAL COIL	
R1-4			RK73FB2A101J	CHIP R 100 J 1/10W	
R5			RK73GB1J103J	CHIP R 10K J 1/16W	
Q1,2		*	2SK3075	FET	
TH1			157-503-65001	THERMISTOR	
CONTROL UNIT (X53-3930-10)					
C1-5			CK73GB1H471K	CHIP C 470PF K	
C8			CK73FB1C474K	CHIP C 0.47UF K	
C12,13			CK73FB1C474K	CHIP C 0.47UF K	
C14			CK73FB1C104KTD	CHIP C 0.10UF K	
C15			CK73GB1H471K	CHIP C 470PF K	
C16			C92-0734-05	CHIP-TAN 100UF 10WV	
C19			CK73FB1C474K	CHIP C 0.47UF K	
C22			CK73GB1H471K	CHIP C 470PF K	
C27-29			CK73GB1C104K	CHIP C 0.10UF K	
C30			CK73FB1C474K	CHIP C 0.47UF K	
C31			CK73GB1E223K	CHIP C 0.022UF K	
C32			CK73FB1C474K	CHIP C 0.47UF K	
C33,34			CK73GB1H471K	CHIP C 470PF K	
C35			CK73GB1H102K	CHIP C 1000PF K	
C37			CC73GCH1H101J	CHIP C 100PF J	
C38			CK73GB1H102K	CHIP C 1000PF K	
C39			CK73GB1H471K	CHIP C 470PF K	
C43			CK73GB1H471K	CHIP C 470PF K	
C45,46			CK73GB1H471K	CHIP C 470PF K	
C103			CK73GB1H102K	CHIP C 1000PF K	
C104,105			CC73GCH1H101J	CHIP C 100PF J	
C106			C92-0602-05	CHIP-TAN 1.0UF 10WV	
CN1			E40-5947-05	FLAT CABLE CONNECTOR	
CN3			E40-5948-05	FLAT CABLE CONNECTOR	
CN4			E40-5662-05	PIN ASSY SOCKET	
CN101			E40-5920-05	FLAT CABLE CONNECTOR	
CN501			E04-0403-05	PIN SOCKET	
L1-4			L92-0141-05	FERRITE CHIP	
L6			L92-0149-05	FERRITE CHIP	
L9			L92-0138-05	FERRITE CHIP	

PARTS LIST

CONTROL UNIT (X53-3930-10)
TX-RX UNIT (X57-608X-XX) 0-10:K, 0-11:K2

Ref. No.	Address	New parts	Parts No.	Description	Destination
L101			L92-0138-05	FERRITE CHIP	
CP1			R90-0723-05	MULTI-COMP 47KX2	
R1			RK73GB1J183J	CHIP R 18K J 1/16W	
R2			RK73GB1J103J	CHIP R 10K J 1/16W	
R3			RK73GB1J470J	CHIP R 47 J 1/16W	
R4,5			RK73GB1J103J	CHIP R 10K J 1/16W	
R6-8			R92-1252-05	CHIP R 0 OHM	
R9,10			RK73GB1J102J	CHIP R 1.0K J 1/16W	
R11			R92-1252-05	CHIP R 0 OHM	
R12			RK73GB1J102J	CHIP R 1.0K J 1/16W	
R13			RK73GB1J473J	CHIP R 47K J 1/16W	
R14			RK73GB1J104J	CHIP R 100K J 1/16W	
R15			RK73GB1J222J	CHIP R 2.2K J 1/16W	
R17,18			RK73GB1J473J	CHIP R 47K J 1/16W	
R22,23			RK73GB1J102J	CHIP R 1.0K J 1/16W	
R26-28			RK73GB1J103J	CHIP R 10K J 1/16W	
R29,30			RK73GB1J223J	CHIP R 22K J 1/16W	
R32			RK73GB1J680J	CHIP R 68 J 1/16W	
R33			RK73GB1J223J	CHIP R 22K J 1/16W	
R34			RK73GB1J182J	CHIP R 1.8K J 1/16W	
R35			RK73GB1J103J	CHIP R 10K J 1/16W	
R36			RK73GB1J182J	CHIP R 1.8K J 1/16W	
R43,44			RK73GB1J473J	CHIP R 47K J 1/16W	
R45-49			RK73GB1J102J	CHIP R 1.0K J 1/16W	
R56			RK73GB1J153J	CHIP R 15K J 1/16W	
R57			R92-1252-05	CHIP R 0 OHM	
R59			RK73GB1J102J	CHIP R 1.0K J 1/16W	
R60			RK73GB1J101J	CHIP R 100 J 1/16W	
R62,63			R92-1252-05	CHIP R 0 OHM	
R66,67			R92-1252-05	CHIP R 0 OHM	
R101			RK73GB1J104J	CHIP R 100K J 1/16W	
R102-104			RK73GB1J103J	CHIP R 10K J 1/16W	
R105			RK73GB1J332J	CHIP R 3.3K J 1/16W	
R106			RK73GB1J274J	CHIP R 270K J 1/16W	
R107			RK73GB1J472J	CHIP R 4.7K J 1/16W	
R108			RK73GB1J100J	CHIP R 10 J 1/16W	
R502			RK73GB1J102J	CHIP R 1.0K J 1/16W	
D2			DTZ3.9(B)	ZENER DIODE	
D12,13			MA2S111	DIODE	
D15			MA2S111	DIODE	
D16			IMN10	DIODE	
D19,20			MA2S111	DIODE	
D101			1SS373	DIODE	
D102,103			B30-2190-05	LED(TY)	
D104			B30-2019-05	LED(RED/GR)	
IC1			TDA7053AT	IC(AUDIO AMP)	
IC2			BU4094BCFV	IC(8bit SHIFT/STORE REGISTER)	
IC3			NJM2904V	IC(APC)	
IC4-6			TC7SH08FU	IC(2ch AND GATE)	
IC10			TC7W04FU	MOS IC	
IC101			LC75824W	IC(LCD DRIVER)	
Q5			2SC4617(S)	TRANSISTOR	
Q6			2SB798(DL,DK)	TRANSISTOR	
Q7,8			2SK1824	FET	
Q14			UMC4	TRANSISTOR	
Q15			2SK1824	FET	

Ref. No.	Address	New parts	Parts No.	Description	Destination
TX-RX UNIT (X57-608X-XX) 0-10:K, 0-11:K2					
C3-5			CK73GB1H103K	CHIP C 0.010UF K	
C6			CC73GCH1H470J	CHIP C 47PF J	K2
C6			CC73GCH1H560J	CHIP C 56PF J	K
C7,8			CK73GB1H103K	CHIP C 0.010UF K	
C9			CK73GB1H102K	CHIP C 1000PF K	
C10			CC73GCH1H120J	CHIP C 12PF J	
C11			CK73GB1H103K	CHIP C 0.010UF K	
C12			CC73GCH1H560J	CHIP C 56PF J	
C13			CC73GCH1H101J	CHIP C 100PF J	
C14			CC73GCH1H470J	CHIP C 47PF J	
C15			CC73GCH1H220J	CHIP C 22PF J	
C16			CK73GB1H103K	CHIP C 0.010UF K	
C17			CK73GB1H102K	CHIP C 1000PF K	
C18			CK73GB1H103K	CHIP C 0.010UF K	
C19			CK73FB1H103K	CHIP C 0.010UF K	K2
C19			CK73FB1H102K	CHIP C 1000PF K	K
C20			CC73GCH1H390J	CHIP C 39PF J	K2
C20			CC73GCH1H680J	CHIP C 68PF J	K
C21			CK73FB1H103K	CHIP C 0.010UF K	
C22			CC73FCH1H270J	CHIP C 27PF J	K2
C22			CC73FCH1H560J	CHIP C 56PF J	K
C23			CC73FCH1H470J	CHIP C 47PF J	K2
C23			CC73FCH1H680J	CHIP C 68PF J	K
C24			CC73FCH1H090D	CHIP C 9.0PF D	K2
C24			CC73FCH1H120J	CHIP C 12PF J	K
C25			CC73FCH1H101J	CHIP C 100PF J	K
C25			CC73FCH1H560J	CHIP C 56PF J	K2
C26,27			CC73FCH1H151J	CHIP C 150PF J	K
C26,27			CC73FCH1H820J	CHIP C 82PF J	K2
C28			CC73FCH1H101J	CHIP C 100PF J	K
C28			CC73FCH1H560J	CHIP C 56PF J	K2
C29			CC73GCH1H680J	CHIP C 68PF J	K2
C29			CC73GCH1H820J	CHIP C 82PF J	K
C30			C92-0560-05	CHIP-TAN 10UF 6.3WV	
C31			CK73GB1H102K	CHIP C 1000PF K	
C32			CC73GCH1H101J	CHIP C 100PF J	
C33,34			CK73GB1H102K	CHIP C 1000PF K	
C35			CK73GB1H103K	CHIP C 0.010UF K	
C36			CK73GB1C104K	CHIP C 0.10UF K	
C37			C92-0543-05	CHIP-TAN 3.3UF 10WV	
C38			CK73GB1C104K	CHIP C 0.10UF K	
C39			CK73GB1H103K	CHIP C 0.010UF K	
C40			CK73HB1C103K	CHIP C 0.010UF K	
C41			CC73HCH1H680J	CHIP C 68PF J	
C42			CK73HB1C103K	CHIP C 0.010UF K	
C43			CC73HCH1H101J	CHIP C 100PF J	K2
C43			CC73HCH1H560J	CHIP C 56PF J	K
C44			CK73HB1C103K	CHIP C 0.010UF K	
C45			CK73GB1H103K	CHIP C 0.010UF K	
C46			CC73GCH1H470J	CHIP C 47PF J	
C47			CC73GCH1H050C	CHIP C 5.0PF C	
C48			CC73GCH1H150J	CHIP C 15PF J	
C101			C92-0712-05	CHIP-TAN 22UF 6.3WV	
C102-104			CK73GB1H103K	CHIP C 0.010UF K	
C105			CK73GB1H102K	CHIP C 1000PF K	
C106			CK73GB1H222K	CHIP C 2200PF K	
C107			CK73GB1H102K	CHIP C 1000PF K	
C108			C92-0560-05	CHIP-TAN 10UF 6.3WV	

PARTS LIST

TX-RX UNIT (X57-608X-XX) 0-10-K, 0-11-K2

Ref. No.	Address	New parts	Parts No.	Description	Destination	Ref. No.	Address	New parts	Parts No.	Description	Destination
C109			CK73GB1H103K	CHIP C 0.010UF K		C214			CC73GCH1H040C	CHIP C 4.0PF C	
C110			CK73GB1H102K	CHIP C 1000PF K		C217			CK73GB1H103K	CHIP C 0.010UF K	
C111			C92-0560-05	CHIP-TAN 10UF 6.3WV		C220			CK73GB1H103K	CHIP C 0.010UF K	
C112			C92-0589-05	CHIP-TAN 47UF 6.3WV		C223			CC73GCH1H470J	CHIP C 47PF J	
C113			C92-0004-05	CHIP-TAN 1.0UF 16WV		C224			CK73GB1H102K	CHIP C 1000PF K	
C114			C92-0714-05	CHIP-TAN 4.7UF 6.3WV		C225			CC73GCH1H470J	CHIP C 47PF J	
C115			CK73GB1H102K	CHIP C 1000PF K		C226			CK73GB1H102K	CHIP C 1000PF K	
C116			CK73HCH1H470J	CHIP C 47PF J		C227			CK73GB1H103K	CHIP C 0.010UF K	
C117			CK73GB1H103K	CHIP C 0.010UF K		C228			CK73GB1H471K	CHIP C 470PF K	
C118			C92-0001-05	CHIP-C 0.1UF 35WV		C229,230			CK73GB1H102K	CHIP C 1000PF K	
C119			C92-0004-05	CHIP-TAN 1.0UF 16WV		C233			CK73GB1H102K	CHIP C 1000PF K	
C120			CK73GB1C473K	CHIP C 0.047UF K		C234			CK73GB1H103K	CHIP C 0.010UF K	
C121			CK73GB1H102K	CHIP C 1000PF K		C237			CC73GCH1H150J	CHIP C 15PF J	
C122			CK73GB1H103K	CHIP C 0.010UF K		C238			CK73GB1H103K	CHIP C 0.010UF K	
C123			C92-0589-05	CHIP-TAN 47UF 6.3WV		C301			CK73GB1H102K	CHIP C 1000PF K	
C124			CC73HCH1H050C	CHIP C 5.0PF C		C302,303			CC73GCH1H010C	CHIP C 1.0PF C	
C125			CC73HCH1H100D	CHIP C 10PF D		C304			CK73GB1H102K	CHIP C 1000PF K	
C126			CK73GB1H103K	CHIP C 0.010UF K		C305			CK73GB1H103K	CHIP C 0.010UF K	
C127			CC73HCH1H101J	CHIP C 100PF J		C306			CK73GB1H102K	CHIP C 1000PF K	
C128			CC73HCH1H560J	CHIP C 56PF J		C307			CK73GB1H103K	CHIP C 0.010UF K	
C129			CK73HB1C103K	CHIP C 0.010UF K		C308			CC73GCH1H471J	CHIP C 470PF J	
C130			CK73HB1H102K	CHIP C 1000PF K		C309			C92-0602-05	CHIP-TAN 1.0UF 10WV	
C131			CK73GB1H103K	CHIP C 0.010UF K		C310,311			CK73GB1C104K	CHIP C 0.10UF K	
C132			CC73HCH1H330J	CHIP C 33PF J		C312			CK73GB1C333K	CHIP C 0.033UF K	
C133			CK73GB1H103K	CHIP C 0.010UF K		C313			CK73GB1H102K	CHIP C 1000PF K	
C134			CC73HCH1H390J	CHIP C 39PF J		C314			CC73GCH1H010C	CHIP C 1.0PF C	
C135			CK73HB1C103K	CHIP C 0.010UF K		C316			CC73GCH1H820J	CHIP C 82PF J	
C136			CK73GB1H102K	CHIP C 1000PF K		C317			CK73GB1H102K	CHIP C 1000PF K	
C137			C92-0714-05	CHIP-TAN 4.7UF 6.3WV		C318			CK73GB1C104K	CHIP C 0.10UF K	
C138,139			CC73GCH1H100D	CHIP C 10PF D		C319			CC73GCH1H030C	CHIP C 3.0PF C	
C140			CC73HCH1H060D	CHIP C 6.0PF D		C320			C92-0560-05	CHIP-TAN 10UF 6.3WV	
C141			CC73HCH1H090D	CHIP C 9.0PF D		C321			CK73GB1H472K	CHIP C 4700PF K	
C142,143			CC73HCH1H180J	CHIP C 18PF J		C322,323			CC73GCH1H221J	CHIP C 220PF J	
C144			CK73GB1H102K	CHIP C 1000PF K		C324			CK73GB1H102K	CHIP C 1000PF K	
C147			CC73GCH1H180J	CHIP C 18PF J		C325			CK73GB1C104K	CHIP C 0.10UF K	
C148			CC73GCH1H390J	CHIP C 39PF J		C326			CK73GB1H102K	CHIP C 1000PF K	
C149			CC73GCH1H180J	CHIP C 18PF J		C327			CK73GB1H103K	CHIP C 0.010UF K	
C150			CC73GCH1H070D	CHIP C 7.0PF D		C328			CK73GB1A224K	CHIP C 0.22UF K	
C151-153			CK73GB1H102K	CHIP C 1000PF K		C329			CK73FB1C334K	CHIP C 0.33UF K	
C154			CK73GB1H103K	CHIP C 0.010UF K		C400,401			CC73HCH1H101J	CHIP C 100PF J	
C157			CC73GCH1H220J	CHIP C 22PF J		C403-407			CK73HB1H102K	CHIP C 1000PF K	
C158			CC73GCH1H470J	CHIP C 47PF J		C408			CK73GB1H102K	CHIP C 1000PF K	
C159			CC73GCH1H220J	CHIP C 22PF J		C409			CK73HB1H102K	CHIP C 1000PF K	
C160			CC73GCH1H090D	CHIP C 9.0PF D		C410			CK73GB1H102K	CHIP C 1000PF K	
C161-163			CK73GB1H102K	CHIP C 1000PF K		C411			CK73HB1H102K	CHIP C 1000PF K	
C164			CC73HCH1H080D	CHIP C 8.0PF D		C413			CK73GB1H471K	CHIP C 470PF K	
C165			CC73HCH1H270J	CHIP C 27PF J		C414			CK73GB1H103K	CHIP C 0.010UF K	
C166,167			CK73HB1H102K	CHIP C 1000PF K		C415			CK73FBOJ105K	CHIP C 1.0UF K	
C168			CC73HCH1H270J	CHIP C 27PF J		C416			CK73GB1H102K	CHIP C 1000PF K	
C169			CC73HCH1H090D	CHIP C 9.0PF D		C417			CK73GB1H471K	CHIP C 470PF K	
C170			C92-0560-05	CHIP-TAN 10UF 6.3WV		C419			C92-0589-05	CHIP-TAN 47UF 6.3WV	
C171			CC73HCH1H070D	CHIP C 7.0PF D		C420			C92-0702-05	ELECTRO 47UF 6.3WV	
C173			CK73HB1H102K	CHIP C 1000PF K		C421			CK73GB1H102K	CHIP C 1000PF K	
C174			CC73HCH1H101J	CHIP C 100PF J		C422			CK73FF1C105Z	CHIP C 1.0UF Z	
C200			CK73GB1H103K	CHIP C 0.010UF K		C423			CC73GCH1H471J	CHIP C 470PF J	
C204			CK73GB1H103K	CHIP C 0.010UF K		C424			CK73GB1H471K	CHIP C 470PF K	
C206			CK73GB1H102K	CHIP C 1000PF K		C425			CK73GB1H103K	CHIP C 0.010UF K	
C207			CK73GB1H103K	CHIP C 0.010UF K		C426			CK73GB1H102K	CHIP C 1000PF K	
C209,210			CK73GB1H103K	CHIP C 0.010UF K		C427			CK73GB1H103K	CHIP C 0.010UF K	
C212,213			CK73GB1H103K	CHIP C 0.010UF K		C428			C92-0004-05	CHIP-TAN 1.0UF 16WV	

PARTS LIST

TX-RX UNIT (X57-608X-XX) 0-10:K, 0-11:K2

Ref. No.	Address	New parts	Parts No.	Description	Destination	Ref. No.	Address	New parts	Parts No.	Description	Destination
C429,430			CK73GB1H102K	CHIP C 1000PF K		C657			C92-0714-05	CHIP-TAN 4.7UF 6.3WV	
C431			CK73GB1H471K	CHIP C 470PF K		C659			CK73GB1C104K	CHIP C 0.10UF K	
C432			CK73FF1C105Z	CHIP C 1.0UF Z		C660			C92-0560-05	CHIP-TAN 10UF 6.3WV	
C433			C92-0698-05	ELECTRO 47UF 16WV		C661			CK73GB1C104K	CHIP C 0.10UF K	
C434			CC73GCH1H471J	CHIP C 470PF J		C663			CK73GB1H102K	CHIP C 1000PF K	
C435			C92-0560-05	CHIP-TAN 10UF 6.3WV		C664			CK73GB1C104K	CHIP C 0.10UF K	
C436			CK73FF1C105Z	CHIP C 1.0UF Z		C665			CK73GB1C333K	CHIP C 0.033UF K	
C437			CK73GB1H472K	CHIP C 4700PF K		C666			CK73GB1E153K	CHIP C 0.015UF K	
C438,439			CK73GB1H103K	CHIP C 0.010UF K		C667			CK73GB1H103K	CHIP C 0.010UF K	
C440			CK73GB1C273K	CHIP C 0.027UF K		C668			CK73GB1H102K	CHIP C 1000PF K	
C441,442			CK73GB1H102K	CHIP C 1000PF K		C681			CK73GB1H103K	CHIP C 0.010UF K	
C443			CK73GB1H222K	CHIP C 2200PF K		CN1	*		E04-0410-05	PIN SOCKET	
C444			CK73GB1H102K	CHIP C 1000PF K		CN400			E40-5563-05	FLAT CABLE CONNECTOR	
C445,446			CK73GB1H222K	CHIP C 2200PF K		CN401			E40-5947-05	FLAT CABLE CONNECTOR	
C447,448			CK73GB1C104K	CHIP C 0.10UF K		CN403			E40-5856-05	FLAT CABLE CONNECTOR	
C449			CK73GB1H103K	CHIP C 0.010UF K		CN404,405			E23-0342-05	TEST TERMINAL	
C450			C92-0713-05	CHIP-TAN 10UF 6.3WV		F400			F53-0143-05	FUSE	
C454			CC73GCH1H101J	CHIP C 100PF J		CD300			L79-1072-05	TUNING COIL	
C456-477			CC73GCH1H101J	CHIP C 100PF J		CF300,301			L72-0916-05	CERAMIC FILTER	
C478			CK73GB1C104K	CHIP C 0.10UF K		L2			L40-6875-44	SMALL FIXED INDUCTOR(68.0NH/16)	
C479			CC73GCH1H271J	CHIP C 270PF J		L3			L40-1095-34	SMALL FIXED INDUCTOR(1UH/8)	
C480			CK73FB1C105K	CHIP C 1.0UF K		L4	*		L40-1885-54	SMALL FIXED INDUCTOR(180NH/201)	
C600			CK73GB1C473K	CHIP C 0.047UF K		L5			L40-1585-54	SMALL FIXED INDUCTOR(150NH/201)	
C601			C92-0003-05	CHIP-TAN 0.47UF 25WV		L7			L92-0176-05	FERRITE CHIP	
C602			CK73GB1C104K	CHIP C 0.10UF K		L8	*		L34-4638-05	AIR-CORE COIL	
C603			CK73GB1C683K	CHIP C 0.068UF K		L9	*		L34-4616-05	AIR-CORE COIL	
C604			CK73GB1H103K	CHIP C 0.010UF K		L10	*		L34-4616-05	AIR-CORE COIL	K
C606			CK73GB1H222K	CHIP C 2200PF K		L10	*		L34-4623-05	AIR-CORE COIL	K2
C607			CC73GCH1H101J	CHIP C 100PF J		L11	*		L34-4637-05	AIR-CORE COIL	
C608			CK73GB1H103K	CHIP C 0.010UF K		L12			L40-1001-81	SMALL FIXED INDUCTOR	
C609			CC73GCH1H121J	CHIP C 120PF J		L13			L40-1005-34	SMALL FIXED INDUCTOR(10UH/8)	
C610			CK73GB1H103K	CHIP C 0.010UF K		L14			L92-0149-05	FERRITE CHIP	
C611			CK73GB1E123K	CHIP C 0.012UF K		L15			L40-3381-37	SMALL FIXED INDUCTOR(0.330UH/8)	
C612			C92-0714-05	CHIP-TAN 4.7UF 6.3WV		L16			L40-2281-37	SMALL FIXED INDUCTOR	K
C613			CK73GB1H103K	CHIP C 0.010UF K		L16			L40-8272-37	SMALL FIXED INDUCTOR	K2
C619			CC73GCH1H471J	CHIP C 470PF J		L17, 18			L40-2281-37	SMALL FIXED INDUCTOR(0.220UH/8)	
C621			CK73GB1C104K	CHIP C 0.10UF K		L19			L40-1091-37	SMALL FIXED INDUCTOR(1.000UH/8)	
C622,623			CK73GB1H103K	CHIP C 0.010UF K		L101			L92-0138-05	FERRITE CHIP	
C625,626			CK73GB1C104K	CHIP C 0.10UF K		L102			L40-4791-37	SMALL FIXED INDUCTOR(4.700UH/8)	
C627			CK73GB1H122J	CHIP C 1200PF J		L103			L40-1581-37	SMALL FIXED INDUCTOR(0.150UH/8)	
C628-630			CK73GB1H103K	CHIP C 0.010UF K		L104			L40-1881-37	SMALL FIXED INDUCTOR(0.180UH/8)	
C631			CK73GB1C104K	CHIP C 0.10UF K		L105			L40-3981-37	SMALL FIXED INDUCTOR(0.390UH/8)	
C632			CK73HB1A104K	CHIP C 0.10UF K		L106,107			L40-5675-44	SMALL FIXED INDUCTOR(56.0NH/16)	
C633			CK73HB1C103K	CHIP C 0.010UF K		L108			L40-1581-37	SMALL FIXED INDUCTOR(0.150UH/8)	
C634,635			CK73GB1H562J	CHIP C 5600PF J		L109			L40-4775-44	SMALL FIXED INDUCTOR(47.0NH/16)	
C636			CK73GB1C333K	CHIP C 0.033UF K		L110			L40-3375-44	SMALL FIXED INDUCTOR(33.0NH/16)	
C637			CK73GB1H562J	CHIP C 5600PF J		L111			L40-1085-44	SMALL FIXED INDUCTOR(100.0NH-1)	
C638			CK73GB1H272J	CHIP C 2700PF J		L112			L40-3375-44	SMALL FIXED INDUCTOR(33.0NH/16)	
C639			CC73GCH1H090D	CHIP C 9.0PF D		L113,114			L40-4775-44	SMALL FIXED INDUCTOR(47.0NH/16)	
C640,641			CK73GB1H272J	CHIP C 2700PF J		L115,116			L40-5675-44	SMALL FIXED INDUCTOR(56.0NH/16)	
C642			CC73GCH1H151J	CHIP C 150PF J		L117			L40-1281-37	SMALL FIXED INDUCTOR(0.120UH/8)	
C643			CK73GB1H122K	CHIP C 1200PF K		L118			L40-8275-44	SMALL FIXED INDUCTOR(82.0NH/16)	
C644			CK73GB1H102K	CHIP C 1000PF K		L119			L40-1281-37	SMALL FIXED INDUCTOR(0.120UH/8)	
C645			CC73GCH1H090D	CHIP C 9.0PF D		L120			L40-8275-44	SMALL FIXED INDUCTOR(82.0NH/16)	
C646			C92-0713-05	CHIP-TAN 10UF 6.3WV		L121			L40-1085-44	SMALL FIXED INDUCTOR(100.0NH-1)	
C647			CK73GB1C104K	CHIP C 0.10UF K		L122			L40-3375-44	SMALL FIXED INDUCTOR(33.0NH/16)	
C649-651			CK73GB1C104K	CHIP C 0.10UF K		L123			L40-1881-37	SMALL FIXED INDUCTOR(0.180UH/8)	
C652			C92-0714-05	CHIP-TAN 4.7UF 6.3WV		L201,202	*		L34-4624-05	COIL	
C653,654			CK73GB1H472K	CHIP C 4700PF K		L203			L40-1081-37	SMALL FIXED INDUCTOR(0.100UH/8)	
C656			CK73FB1H563K	CHIP C 0.056UF K		L206	*		L34-4624-05	COIL	

PARTS LIST

TX-RX UNIT (X57-608X-XX) 0-10-K, 0-11-K2

Ref. No.	Address	New parts	Parts No.	Description	Destination	Ref. No.	Address	New parts	Parts No.	Description	Destination
L208			L40-1281-37	SMALL FIXED INDUCTOR(0.120UH/8)		R104			R92-1252-05	CHIP R 0 OHM	
L211,212			L39-1272-05	TOROIDAL COIL		R106			RK73GB1J560J	CHIP R 56 J 1/16W	
L213			L92-0138-05	FERRITE CHIP		R107,108			RK73GB1J100J	CHIP R 10 J 1/16W	
L214			L39-1272-05	TOROIDAL COIL		R109			R92-1252-05	CHIP R 0 OHM	
L301			L40-2781-37	SMALL FIXED INDUCTOR(0.270UH/8)		R110			RK73GB1J152J	CHIP R 1.5K J 1/16W	
L302-304		*	L34-4625-05	COIL		R111,112			RK73GB1J100J	CHIP R 10 J 1/16W	
L306			L40-2281-37	SMALL FIXED INDUCTOR(0.220UH/8)		R113			RK73HB1J333J	CHIP R 33K J 1/16W	
L307			L40-1581-37	SMALL FIXED INDUCTOR(0.150UH/8)		R114			RK73HB1J154J	CHIP R 150K J 1/16W	
L308			L40-1081-37	SMALL FIXED INDUCTOR		R115			RK73GB1J102J	CHIP R 1.0K J 1/16W	
L309			L40-2281-37	SMALL FIXED INDUCTOR		R116			RK73GB1J182J	CHIP R 1.8K J 1/16W	
L400			L92-0136-05	FERRITE CHIP		R117			RK73HB1J100J	CHIP R 10 J 1/16W	
L401			L92-0138-05	FERRITE CHIP		R118			RK73HB1J331J	CHIP R 330 J 1/16W	
L403			L92-0138-05	FERRITE CHIP		R119			RK73GB1J223J	CHIP R 22K J 1/16W	
L404			L40-1001-37	SMALL FIXED INDUCTOR(10.00UH/8)		R120			RK73GB1J102J	CHIP R 1.0K J 1/16W	
L405,406			L92-0138-05	FERRITE CHIP		R121,122			RK73GB1J222J	CHIP R 2.2K J 1/16W	
L601-603			L92-0140-05	FERRITE CHIP		R123			RK73GB1J180J	CHIP R 18 J 1/16W	
L604			L92-0138-05	FERRITE CHIP		R124			RK73HB1J180J	CHIP R 18 J 1/16W	
L800		*	L78-0481-05	VCO		R125			RK73HB1J471J	CHIP R 470 J 1/16W	
X101		*	L77-1832-05	VCXO(16.8MHZ/4P/16)		R126			RK73GB1J471J	CHIP R 470 J 1/16W	
X600		*	L77-1708-05	CRYSTAL RESONATOR(3.579545MHZ)		R127			RK73GB1J560J	CHIP R 56 J 1/16W	
XF300		*	L71-0559-05	MCF(128.55MHz)		R128			RK73GB1J102J	CHIP R 1.0K J 1/16W	
CP101			R90-0741-05	MULTIPLE RESISTOR		R129			RK73GB1J331J	CHIP R 330 J 1/16W	
CP401-418			R90-0741-05	MULTIPLE RESISTOR		R130			RK73GB1J102J	CHIP R 1.0K J 1/16W	
R1			RK73GB1J123J	CHIP R 12K J 1/16W		R131			RK73GB1J223J	CHIP R 22K J 1/16W	
R2			RK73GB1J100J	CHIP R 10 J 1/16W	K	R133			RK73HB1J221J	CHIP R 220 J 1/16W	
R2			RK73GB1J150J	CHIP R 15 J 1/16W	K2	R134			RK73GB1J102J	CHIP R 1.0K J 1/16W	
R3			RK73GB1J100J	CHIP R 10 J 1/16W		R135			RK73HB1J334J	CHIP R 330K J 1/16W	
R4			RK73GB1J151J	CHIP R 150 J 1/16W	K2	R137			RK73HB1J101J	CHIP R 100 J 1/16W	
R4			RK73GB1J271J	CHIP R 270 J 1/16W	K	R139			RK73GB1J680J	CHIP R 68 J 1/16W	
R5			RK73GB1J180J	CHIP R 18 J 1/16W	K	R140			RK73GB1J561J	CHIP R 560 J 1/16W	
R5			RK73GB1J390J	CHIP R 39 J 1/16W	K2	R141			RK73GB1J224J	CHIP R 220K J 1/16W	
R6			RK73GB1J151J	CHIP R 150 J 1/16W	K2	R143			RK73HB1J100J	CHIP R 10 J 1/16W	
R6			RK73GB1J271J	CHIP R 270 J 1/16W	K	R144			RK73HB1J222J	CHIP R 2.2K J 1/16W	
R7			RK73GB1J560J	CHIP R 56 J 1/16W		R145			RK73HB1J104J	CHIP R 100K J 1/16W	
R8			RK73GB1J103J	CHIP R 10K J 1/16W		R146			R92-1252-05	CHIP R 0 OHM	
R10 -12			RK73GB1J821J	CHIP R 820 J 1/16W		R147,148			RK73GB1J470J	CHIP R 47 J 1/16W	
R13			RK73GB1J100J	CHIP R 10 J 1/16W		R149,150			RK73GB1J103J	CHIP R 10K J 1/16W	
R14 -16			RK73EB2ER39K	CHIP R 0.39 K 1/4W		R151			RK73HB1J102J	CHIP R 1.0K J 1/16W	
R17 -22			RN73GH1J154D	CHIP R 150K D 1/16W		R152			RK73GB1J101J	CHIP R 100 J 1/16W	
R23			RK73GB1J103J	CHIP R 10K J 1/16W		R153			RK73GB1J100J	CHIP R 10 J 1/16W	
R24			RK73GB1J222J	CHIP R 2.2K J 1/16W		R154			RK73GB1J470J	CHIP R 47 J 1/16W	
R25			RK73GB1J103J	CHIP R 10K J 1/16W		R155			R92-1252-05	CHIP R 0 OHM	
R26			RK73GB1J105J	CHIP R 1.0M J 1/16W		R156			RK73GB1J470J	CHIP R 47 J 1/16W	
R27			RK73GB1J393J	CHIP R 39K J 1/16W		R157			RK73HB1J102J	CHIP R 1.0K J 1/16W	
R28			R92-1252-05	CHIP R 0 OHM		R158			RK73HB1J101J	CHIP R 100 J 1/16W	
R29			RK73GB1J473J	CHIP R 47K J 1/16W		R159-161			R92-1252-05	CHIP R 0 OHM	
R30,31			RK73GB1J104J	CHIP R 100K J 1/16W		R200			RK73GB1J473J	CHIP R 47K J 1/16W	
R32			RK73HB1J104J	CHIP R 100K J 1/16W		R201,202			RK73GB1J104J	CHIP R 100K J 1/16W	
R33			RK73HB1J100J	CHIP R 10 J 1/16W		R203			RK73GB1J334J	CHIP R 330K J 1/16W	
R34			RK73GB1J104J	CHIP R 100K J 1/16W		R204			RK73GB1J680J	CHIP R 68 J 1/16W	
R35			RK73GB1J102J	CHIP R 1.0K J 1/16W		R205			RK73GB1J104J	CHIP R 100K J 1/16W	
R36 -38			RK73GB1J104J	CHIP R 100K J 1/16W		R206			RK73GB1J473J	CHIP R 47K J 1/16W	
R40			RK73HB1J221J	CHIP R 220 J 1/16W		R208			RK73GB1J561J	CHIP R 560 J 1/16W	
R41			RK73HB1J471J	CHIP R 470 J 1/16W		R209			RK73GB1J100J	CHIP R 10 J 1/16W	
R42			RK73GB1J151J	CHIP R 150 J 1/16W		R210			R92-1252-05	CHIP R 0 OHM	
R43			RK73GB1J331J	CHIP R 330 J 1/16W		R211			RK73GB1J104J	CHIP R 100K J 1/16W	
R44			R92-1252-05	CHIP R 0 OHM		R212			RK73GB1J222J	CHIP R 2.2K J 1/16W	
R101,102			RK73GB1J473J	CHIP R 47K J 1/16W		R213			RK73GB1J271J	CHIP R 270 J 1/16W	
R103			RK73GB1J560J	CHIP R 56 J 1/16W		R214			RK73GB1J101J	CHIP R 100 J 1/16W	
						R216			R92-1252-05	CHIP R 0 OHM	

PARTS LIST

TX-RX UNIT (X57-608X-XX) 0-10:K, 0-11:K2

Ref. No.	Address	New parts	Parts No.	Description	Destination	Ref. No.	Address	New parts	Parts No.	Description	Destination
R218,219			R92-1252-05	CHIP R 0 OHM		R450			RK73GB1J473J	CHIP R 47K J 1/16W	
R222,223			R92-1252-05	CHIP R 0 OHM		R451			RK73GB1J103J	CHIP R 10K J 1/16W	
R225			RK73GB1J222J	CHIP R 2.2K J 1/16W		R452-455			RK73GB1J104J	CHIP R 100K J 1/16W	
R226			R92-1252-05	CHIP R 0 OHM		R456-458			RK73GB1J473J	CHIP R 47K J 1/16W	
R301			RK73GB1J101J	CHIP R 100 J 1/16W		R459-462			R92-1252-05	CHIP R 0 OHM	
R312			RK73GB1J100J	CHIP R 10 J 1/16W		R463,464			RK73GB1J473J	CHIP R 47K J 1/16W	
R313			RK73GB1J331J	CHIP R 330 J 1/16W		R465			RK73HB1J102J	CHIP R 1.0K J 1/16W	
R314,315			RK73GB1J102J	CHIP R 1.0K J 1/16W		R466-469			RK73GB1J473J	CHIP R 47K J 1/16W	
R320			RK73GB1J182J	CHIP R 1.8K J 1/16W		R470-473			R92-1252-05	CHIP R 0 OHM	
R321			RK73GB1J102J	CHIP R 1.0K J 1/16W		R474			RK73GB1J103J	CHIP R 10K J 1/16W	
R322			RK73GB1J274J	CHIP R 270K J 1/16W		R475,476			RK73HB1J102J	CHIP R 1.0K J 1/16W	
R323			RK73GB1J182J	CHIP R 1.8K J 1/16W		R477			RK73GB1J101J	CHIP R 100 J 1/16W	
R324			RK73GB1J183J	CHIP R 18K J 1/16W		R478			R92-1252-05	CHIP R 0 OHM	
R325			RK73GB1J223J	CHIP R 22K J 1/16W		R479			RK73HB1J102J	CHIP R 1.0K J 1/16W	
R326			RK73GB1J224J	CHIP R 220K J 1/16W		R480			RK73GB1J473J	CHIP R 47K J 1/16W	
R327			RK73GB1J332J	CHIP R 3.3K J 1/16W		R481			R92-1252-05	CHIP R 0 OHM	
R328			RK73GB1J471J	CHIP R 270 J 1/16W		R482			RK73GB1J473J	CHIP R 47K J 1/16W	
R330			RK73GB1J393J	CHIP R 39K J 1/16W		R601			RK73GB1J153J	CHIP R 15K J 1/16W	
R331			RK73GB1J124J	CHIP R 120K J 1/16W		R602			RK73GB1J223J	CHIP R 22K J 1/16W	
R333			R92-1252-05	CHIP R 0 OHM		R603			R92-1252-05	CHIP R 0 OHM	
R334			RK73GB1J100J	CHIP R 10 J 1/16W		R605,606			R92-1252-05	CHIP R 0 OHM	
R335			RK73GB1J473J	CHIP R 47K J 1/16W		R607			RK73GB1J153J	CHIP R 15K J 1/16W	
R400			RK73GB1J102J	CHIP R 1.0K J 1/16W		R608			RK73GB1J103J	CHIP R 10K J 1/16W	
R401			RK73GB1J272J	CHIP R 2.7K J 1/16W		R609			RK73GB1J154J	CHIP R 150K J 1/16W	
R402			RK73GB1J332J	CHIP R 3.3K J 1/16W		R610			RK73GB1J563J	CHIP R 56K J 1/16W	
R403			RK73GB1J473J	CHIP R 47K J 1/16W		R611			RK73GB1J184J	CHIP R 180K J 1/16W	
R404			RK73GB1J182J	CHIP R 1.8K J 1/16W		R612			RK73GB1J334J	CHIP R 330K J 1/16W	
R405			RK73GB1J474J	CHIP R 470K J 1/16W		R614			RK73GB1J184J	CHIP R 180K J 1/16W	
R407			RK73GB1J102J	CHIP R 1.0K J 1/16W		R615,616			RK73GB1J103J	CHIP R 10K J 1/16W	
R408			RK73GB1J104J	CHIP R 100K J 1/16W		R617			R92-1252-05	CHIP R 0 OHM	
R409			RK73GB1J102J	CHIP R 1.0K J 1/16W		R618			RK73GB1J333J	CHIP R 33K J 1/16W	
R410			RK73GB1J473J	CHIP R 47K J 1/16W		R621			RK73GB1J683J	CHIP R 68K J 1/16W	
R411			RK73GB1J472J	CHIP R 4.7K J 1/16W		R622			RK73GB1J223J	CHIP R 22K J 1/16W	
R412			RK73GB1J182J	CHIP R 1.8K J 1/16W		R623			RK73GB1J334J	CHIP R 330K J 1/16W	
R413			RK73GB1J473J	CHIP R 47K J 1/16W		R625			RK73GB1J101J	CHIP R 100 J 1/16W	
R414			R92-1252-05	CHIP R 0 OHM		R626			RK73GB1J104J	CHIP R 100K J 1/16W	
R415			RK73GB1J471J	CHIP R 470 J 1/16W		R629			RK73GB1J223J	CHIP R 22K J 1/16W	
R416			RK73GB1J104J	CHIP R 100K J 1/16W		R631			RK73GB1J103J	CHIP R 10K J 1/16W	
R417			RK73GB1J102J	CHIP R 1.0K J 1/16W		R636			R92-1252-05	CHIP R 0 OHM	
R418,419			RK73GB1J104J	CHIP R 100K J 1/16W		R637			RK73HB1J472J	CHIP R 4.7K J 1/16W	
R420			RK73GB1J103J	CHIP R 10K J 1/16W		R638			RK73GB1J472J	CHIP R 4.7K J 1/16W	
R421			RK73GB1J223J	CHIP R 22K J 1/16W		R639			RN73GH1J913D	CHIP R 91K D 1/16W	
R422			RK73GB1J103J	CHIP R 10K J 1/16W		R640			RN73GH1J683D	CHIP R 68K D 1/16W	
R423			RK73GB1J473J	CHIP R 47K J 1/16W		R641			RN73GH1J913D	CHIP R 91K D 1/16W	
R424			RK73GB1J103J	CHIP R 10K J 1/16W		R642			RN73GH1J333D	CHIP R 33K D 1/16W	
R425			RK73GB1J100J	CHIP R 10 J 1/16W		R643			RK73GB1J564J	CHIP R 560K J 1/16W	
R426-429			RK73GB1J103J	CHIP R 10K J 1/16W		R644			RK73GB1J474J	CHIP R 470K J 1/16W	
R430			RK73GB1J473J	CHIP R 47K J 1/16W		R645			RN73GH1J274D	CHIP R 270K D 1/16W	
R431			RK73GB1J100J	CHIP R 10 J 1/16W		R646			RK73GB1J332J	CHIP R 3.3K J 1/16W	
R432,433			RK73GB1J473J	CHIP R 47K J 1/16W		R648			RN73GH1J913D	CHIP R 91K D 1/16W	
R434			RK73GB1J103J	CHIP R 10K J 1/16W		R649			RN73GH1J682D	CHIP R 6.8K D 1/16W	
R435,436			RK73GB1J102J	CHIP R 1.0K J 1/16W		R650			RK73GB1J473J	CHIP R 47K J 1/16W	
R438-440			RK73GB1J102J	CHIP R 1.0K J 1/16W		R651			RK73GB1J155J	CHIP R 1.5M J 1/16W	
R441			RK73GB1J473J	CHIP R 47K J 1/16W		R652			RK73GB1J473J	CHIP R 47K J 1/16W	
R442			RK73GB1J152J	CHIP R 1.5K J 1/16W		R653			RK73GB1J184J	CHIP R 180K J 1/16W	
R443			RK73GB1J821J	CHIP R 820 J 1/16W		R654			RN73GH1J683D	CHIP R 68K D 1/16W	
R444,445			R92-1252-05	CHIP R 0 OHM		R655			RK73GB1J474J	CHIP R 470K J 1/16W	
R446			RK73GB1J472J	CHIP R 4.7K J 1/16W		R656			RN73GH1J682D	CHIP R 6.8K D 1/16W	
R447			RK73GB1J473J	CHIP R 47K J 1/16W		R657			RK73GB1J101J	CHIP R 100 J 1/16W	
R448,449			RK73GB1J102J	CHIP R 1.0K J 1/16W		R658			RK73GB1J224J	CHIP R 220K J 1/16W	

PARTS LIST

TX-RX UNIT (X57-608X-XX) 0-10-K, 0-11-K2

Ref. No.	Address	New parts	Parts No.	Description	Destination	Ref. No.	Address	New parts	Parts No.	Description	Destination
R660			RK73GB1J223J	CHIP R 22K J 1/16W		Q104,105			2SC4617(R)	TRANSISTOR	
R661			RK73GB1J394J	CHIP R 390K J 1/16W		Q106			2SC4649(N,P)	TRANSISTOR	
R662			RK73GB1J470J	CHIP R 47 J 1/16W		Q200			3SK131(L)	FET	
R663			RK73GB1J220J	CHIP R 22 J 1/16W		Q302			2SK1215(E)	FET	
R664			RK73GB1J333J	CHIP R 33K J 1/16W		Q304			2SC4617(S)	TRANSISTOR	
R665-666			R92-1252-05	CHIP R 0 OHM		Q400			UMG3N	TRANSISTOR	
R668			RK73GB1J334J	CHIP R 330K J 1/16W		Q401			2SK1824	FET	
R669			R92-1252-05	CHIP R 0 OHM		Q402			2SA1362(Y)	TRANSISTOR	
R670-673			RK73GB1J472J	CHIP R 4.7K J 1/16W		Q403			2SJ243	FET	
R674			RK73GB1J104J	CHIP R 100K J 1/16W		Q404			DTC144EE	DIGITAL TRANSISTOR	
R675			RK73GB1J473J	CHIP R 47K J 1/16W		Q405			DTB123YK	DIGITAL TRANSISTOR	
R677			RK73GB1J333J	CHIP R 33K J 1/16W		Q406,407			DTA123JE	DIGITAL TRANSISTOR	
R679			R92-1252-05	CHIP R 0 OHM		Q408-410			2SC4617(S)	TRANSISTOR	
D1			DTZ4.3(A)	ZENER DIODE		Q411			2SB1132(Q,R)	TRANSISTOR	
D2,3			XB15A709	DIODE		Q413			HN1L02FU	FET	
D102			DAN235E	DIODE		Q414			2SK1824	FET	
D201			KV1460	VARIABLE CAPACITANCE DIODE		Q415	*		2SJ517	FET	
D203			KV1460	VARIABLE CAPACITANCE DIODE		Q416			2SK1824	FET	
D207			KV1460	VARIABLE CAPACITANCE DIODE		Q601,602			2SK1824	FET	
D301			MA742	DIODE		TH301			157-503-65001	THERMISTOR	
D400			1SR154-400	DIODE							
D401			MA2S111	DIODE							
D402,403			NNCD6.8G	ZENER DIODE							
D404,405			1SS301	DIODE							
D409			MA2S111	DIODE							
D601			MA742	DIODE							
IC1			M62354GP	MOS IC							
IC2			NJM2904V	IC(APC)							
IC101		*	LMX2332LTMX	ANALOG IC							
IC200			GN2011(Q)	IC							
IC300			TA31136FN	IC(FM IF DETECTOR)							
IC301			TC7S66FU	IC(ANALOG SWITCH)							
IC400			BU4094BCFV	IC(8bit SHIFT/STORE REGISTER)							
IC401,402			TK11250BM	IC(VOLTAGE REGULATOR)							
IC403-405			BU4094BCFV	IC(8bit SHIFT/STORE REGISTER)							
IC406		*	784214GC0618EU	MPU							
IC409			PST9132NR	IC							
IC412			AT2408N10S12.5	IC(8kbit SERIAL EEPROM)							
IC413			TC75W51FU	IC(OP AMP X2)							
IC414			AT29C020-90TI	IC							
IC415			TC7S02F	IC(NOR GATE)							
IC416			TC7WU04FU	IC(INVERTOR)							
IC417			TC7S04FU	IC(INVERTER)							
IC600			LC73872M	IC(DTMF RECEIVER)							
IC601			TC75W51FU	IC(OP AMP X2)							
IC602			TA75W01FU	IC(OP AMP X2)							
IC603			M62364FP	IC(D/A CONVERTER)							
IC604			TC75W51FU	IC(OP AMP X2)							
IC606			TC75W51FU	IC(OP AMP X2)							
IC607			TC35453F	IC(AUDIO PROCESSOR)							
Q1		*	2SC3356(R23)	TRANSISTOR							
Q2		*	2SK3074	FET							
Q4			DTC114EE	DIGITAL TRANSISTOR							
Q5			2SK1824	FET							
Q7,8			HN1L02FU	FET							
Q32			2SC4649(N,P)	TRANSISTOR							
Q101			2SC4617(S)	TRANSISTOR							
Q102			3SK131(L)	FET							
Q103			2SC4649(N,P)	TRANSISTOR							

EXPLODED VIEW

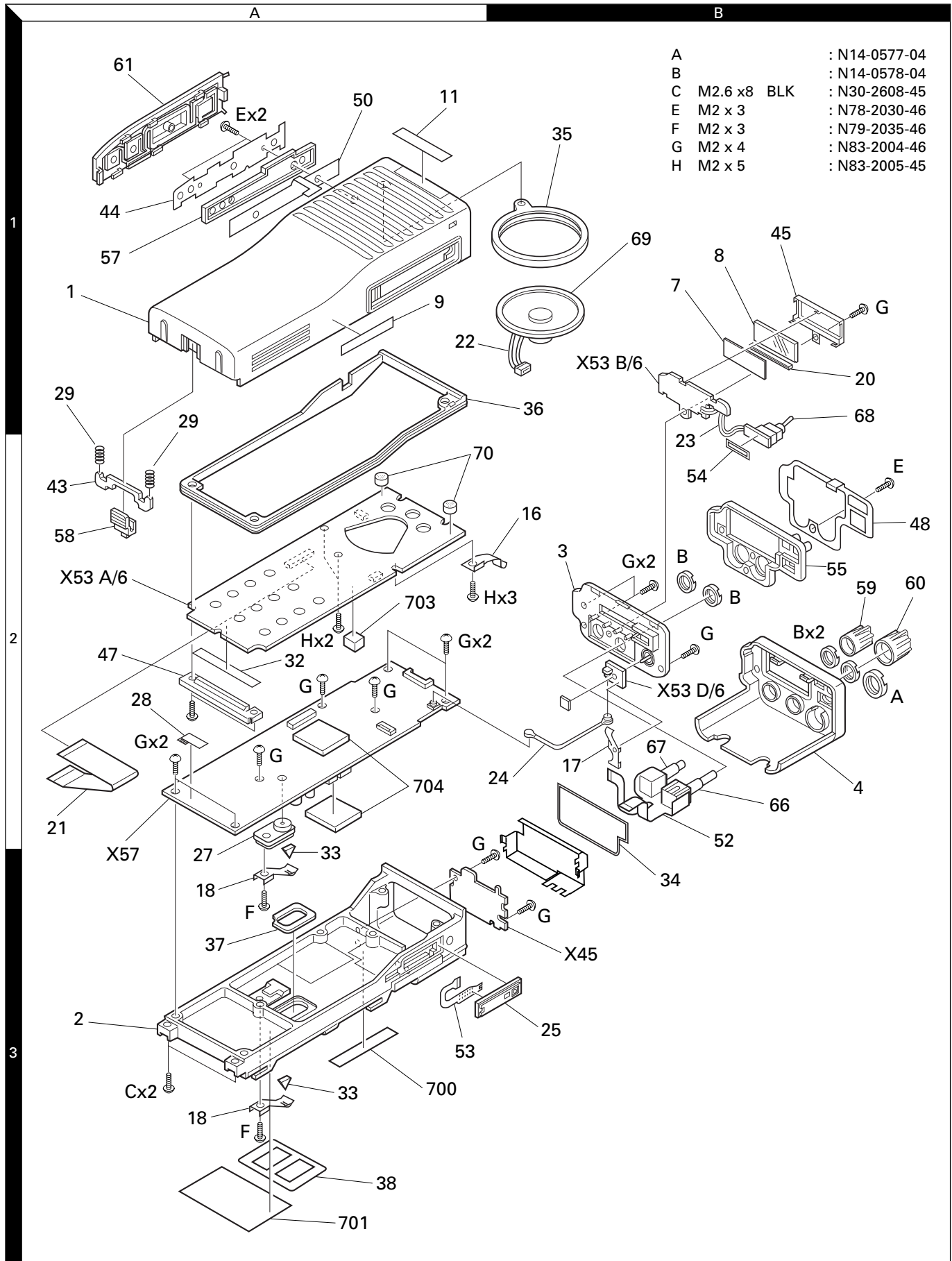

A	:	N14-0577-04
B	:	N14-0578-04
C	M2.6 x8	BLK : N30-2608-45
E	M2 x 3	: N78-2030-46
F	M2 x 3	: N79-2035-46
G	M2 x 4	: N83-2004-46
H	M2 x 5	: N83-2005-45

1

2

3

PACKING

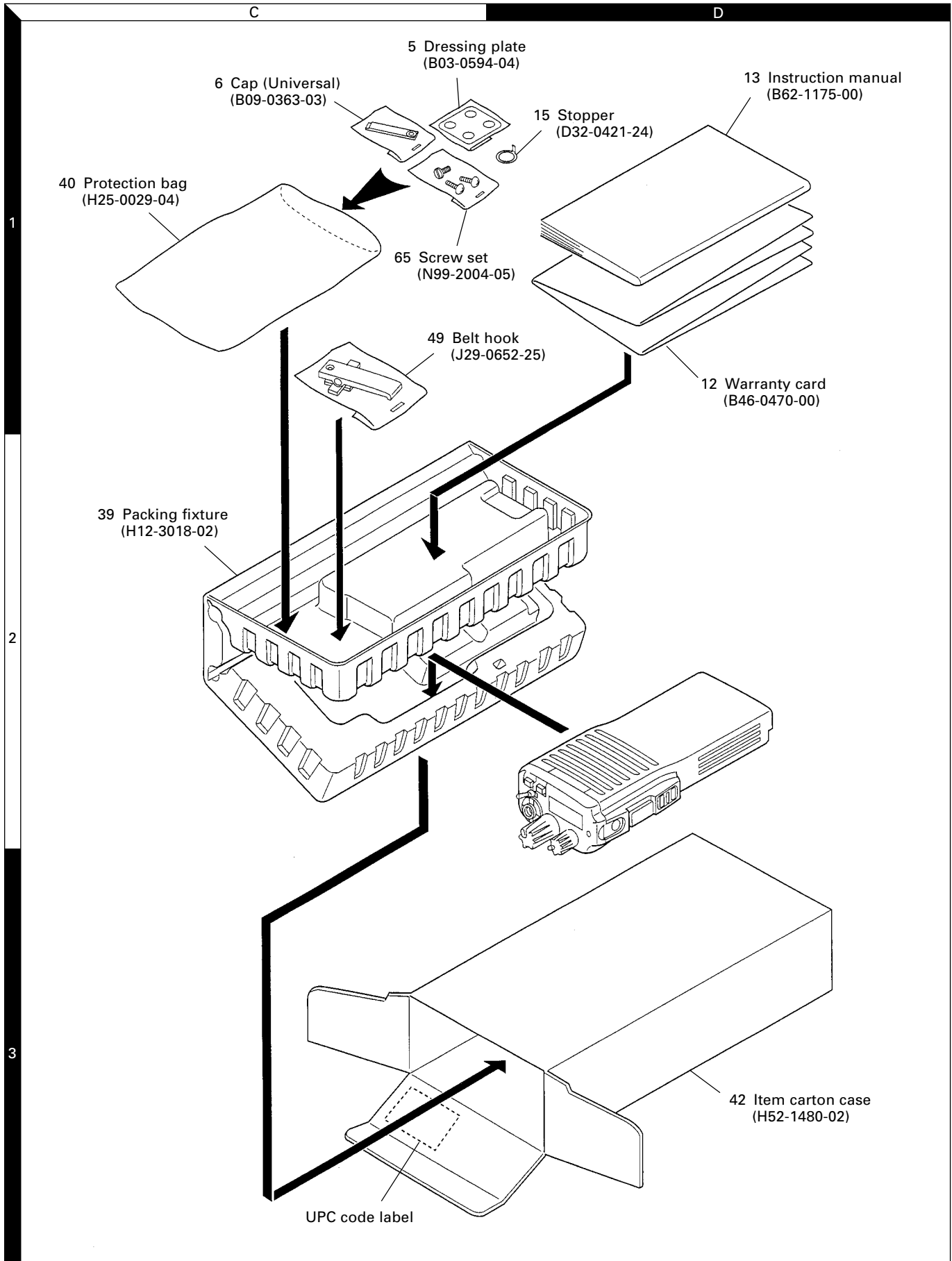

DISASSEMBLY FOR REPAIR

Disassembly of Front Case and Chassis

1. Remove the 2 screws (1) and a cap fixed screw (2).
2. Press the chassis bottom upwards and remove the clips (3) at the top. The front case is still connected to the chassis by the FPC at this time so be gentle when lifting upwards, otherwise unwanted stress is applied on the FPC.
3. The front case and chassis can only be opened to the side when connected by the FPC (4).

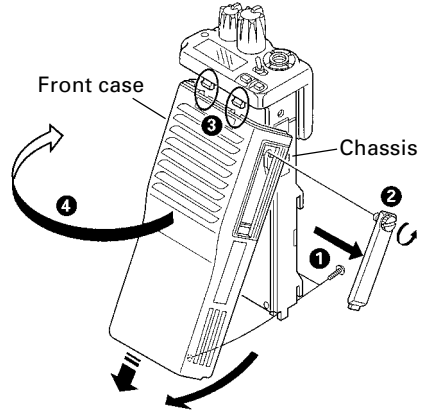

Remove the Side Key Assy

1. The side key assy is clips form a slide-hook structure. Lift up gently and take from the side (12).

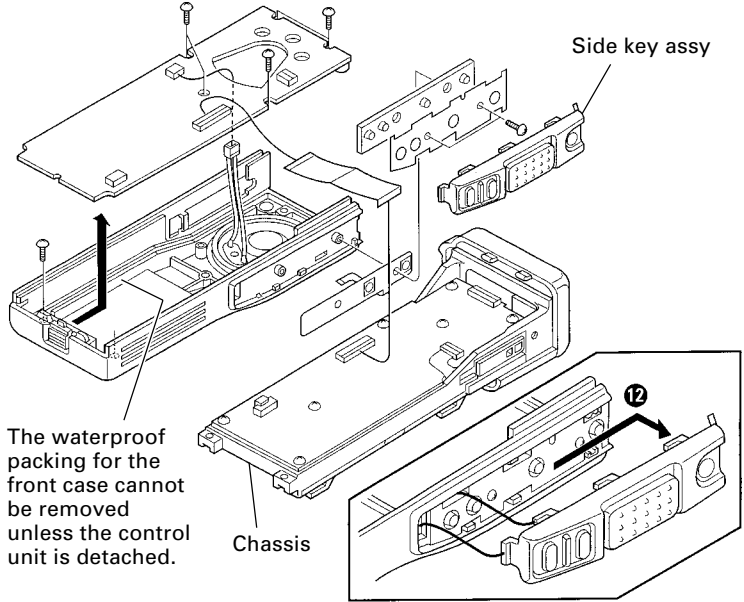

Remove the TX-RX Unit from the Chassis

1. The TX-RX unit cannot be removed simply by removing the seven screws (5).
2. A total of 9 solder connections, 6 on the RF power module (6) and 3 on the antenna daughter board (7) must be disconnected.

Remove the Universal Connector

1. The universal connector (8) is fastened to the chassis with double-side tape.
2. Press firmly with a tool such as a screwdriver and so that it can peel (10).

Note : You must replace both parts together when replacing the universal connector or the FPC (11).

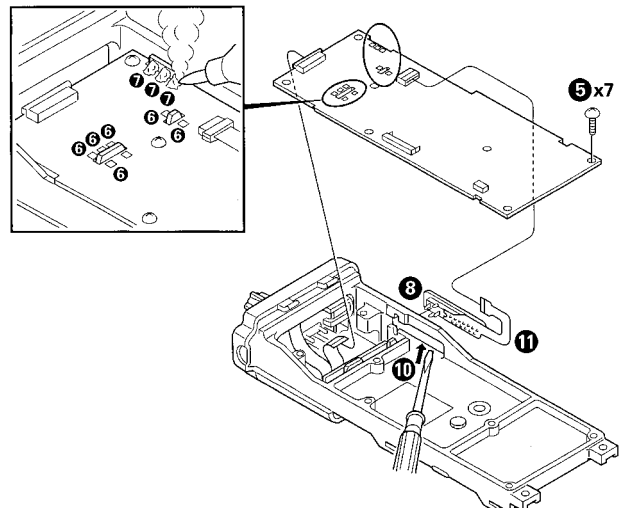

Disassembly of the Panel Assy

1. The LCD assy and toggle switch are joined by wire (13). Use caution not to break this wire during handling.

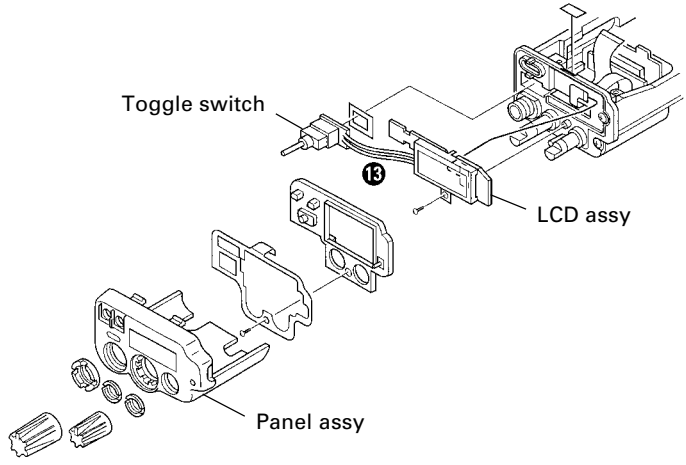

ADJUSTMENT

Test Equipment Required for Alignment

No.	Test Equipment	Major Specifications	
1	Standard Signal Generator (SSG)	Frequency Range Modulation Output	Maximum 50MHz or more. Frequency modulation and external modulation. -133dBm/0.05μV to 7dBm/501mV
2	Power Meter	Input Impedance Operation Frequency Measurement Range	50Ω. Up to 50MHz. Full scale of 10W or so.
3	Deviation Meter	Frequency Range	20 to 50MHz.
4	Digital Volt Meter (DVM)	Measuring Range Accuracy	FS=18V or so. High input impedance for minimum circuit loading.
5	Oscilloscope		DC through 30MHz.
6	High Sensitivity Frequency Counter	Frequency Range Frequency Stability	Up to 1GHz or so. 0.2ppm or less.
7	Ammeter		5A.
8	AF Volt Meter (AF VTVM)	Frequency Range Voltage Range	50Hz to 1MHz. 1mV to 10V.
9	Audio Generator (AG)	Frequency Range Output	100Hz to 100kHz or more. 0 to 1V.
10	Distortion Meter	Capability Input Level	3% or less at 1kHz. 50mV to 10Vrms.
11	16Ω Dummy Load		Approx. 16Ω, 5W.
12	Regulated Power Supply		5V to 10V, approx. 5A Useful if ammeter equipped.
13	Spectrum Analyzer	Measuring Range	DC to 1GHz or more.
14	Tracking Generator	Center Frequency Frequency Deviation Output Voltage	50kHz to 600MHz. ±35MHz. 100mV or more.

■ The following parts are required for adjustment

1. Antenna connector adapter

The antenna connector of this radio uses an SMA terminal.

Use an antenna connector adapter [SMA(f) – BNC(f) or SMA(f) – N(f)] for adjustment. (The adapter is not provided as an option, so buy a commercially-available one.)

Note

When the antenna connector adapter touches the knob, draw out the knob to mount the connector.

2. Universal connector

Use the interface cable (KPG-36) for PC tuning or the lead wire with plug (E30-3287-08) and screw (N08-0535-08) for panel tuning. Connect the plug to the universal connector of the radio and tighten the screw.

The lead wire with plug (E30-3287-08) and screw (N08-0535-08) terminals are as follows. Numbers are universal connector terminal numbers.

Caution

1. When connecting the plug to the universal connector of the radio, a short circuit may occur. To prevent this, be sure to turn the radio POWER switch off.
2. Since the RX AF output is a BTL output, there is a DC component. Isolate this with a capacitor or transformer as shown in the figure.
3. Do not connect an instrument between red or black and GND.

• Universal connector

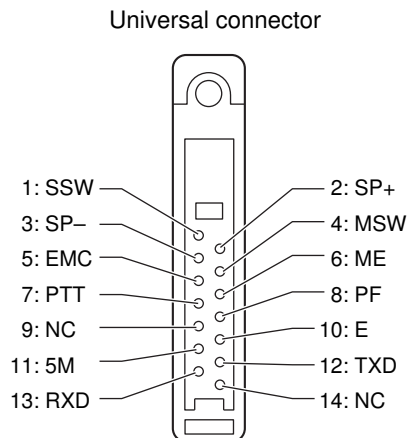

ADJUSTMENT

• Panel tuning

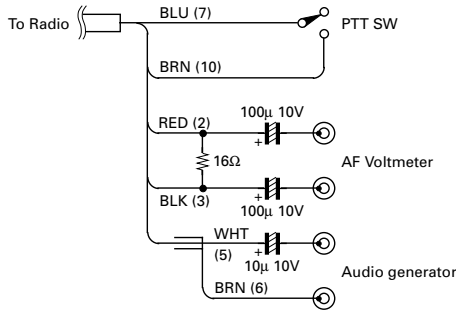
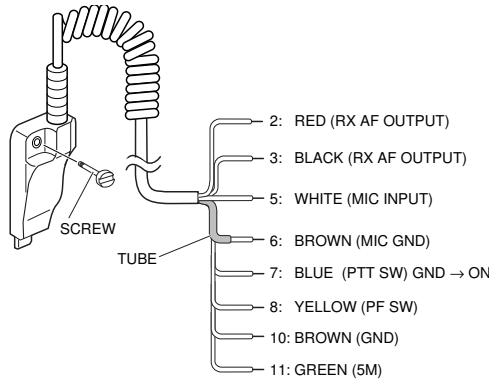

• PC tuning

Connect the wires to the PCB in the connector case of interface cable.

For output the wires out of the connector case, need to process the connector case.

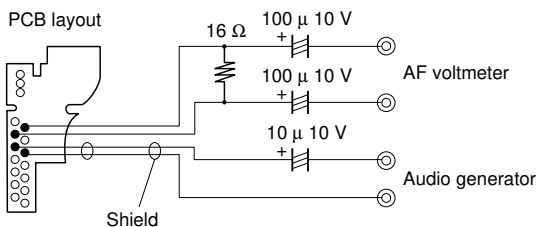
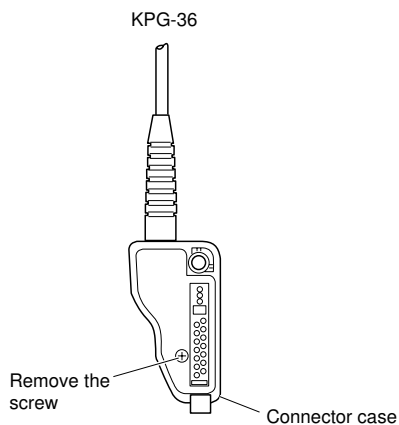

Repair Jig (Chassis)

Use jig (part No.: W05-0824-00) for repairing the TK-190. Place the TX-RX unit on the jig and fit it with 7 screws.

Note : Supply power from an external power supply (Battery terminal : +, jig (chassis) : -)

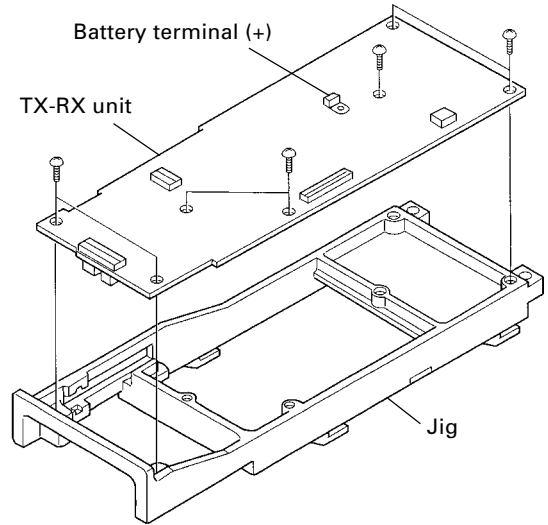

How to Remove the Flat Cable

1. Gently draw out both sides of the connector lever uniformly in the direction of the arrow with tweezers. (CN101, CN400)

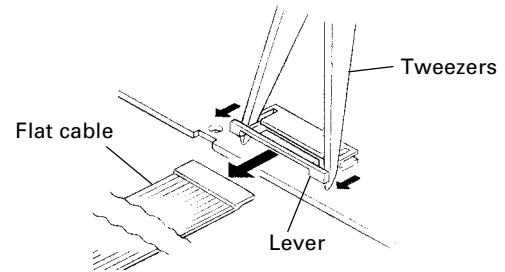

2. Gently rise up the connector lever in the direction of the arrow with a fine regular screwdriver or tweezers. (CN1, CN3, CN401, CN403)

Note : Gently push both sides of the connector lever, when put in the flat cable.

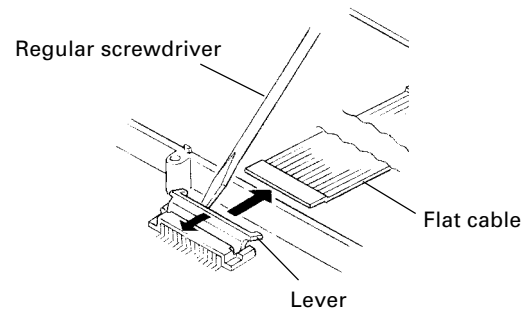

ADJUSTMENT

Panel Test Mode

This mode is used for making transceiver connection tests and clearing the memory.

To set Panel test mode, turn on the power with [Side 2] and [PTT] are still held down and then first release [PTT]. This mode cannot be set when disabled with the FPU.

In Panel test mode, when channel or signalling is selected, the signalling that was most recently used is displayed.

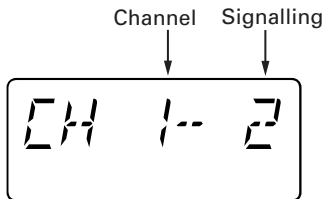

Key operations in Panel test mode are as follows.

- [Selector switch] : Use to select the test channel.
- [PTT] : For transmit.
- [TOP 1] : For down signalling.
- [TOP 2] : For up signalling.
- [Side 1] : For setting Panel tuning mode.
- [Side 2] : For switching power between Hi/Low. Enter the LCD all lamp mode if held down.
- [Orange] : For monitoring.
- [Toggle] : No function.

Frequency

CH	K		K2	
	RX (MHz)	TX (MHz)	RX (MHz)	TX (MHz)
1	33.4000 (Center)	33.3000 (Center)	42.6000 (Center)	42.5000 (Center)
2	29.8000 (Low)	29.7000 (Low)	35.1000 (Low)	35.0000 (Low)
3	36.9000 (Hi)	37.0000 (Hi)	49.9000 (Hi)	50.0000 (Hi)
4	33.3000	33.3000	42.5000	42.5000
5	33.5000	33.5000	42.7000	42.7000
6	33.7000	33.7000	42.9000	42.9000

Note : Internal beat interference exists at both 33.660MHz and 42.000MHz.

Signalling

No.	Encode tone	Decode tone
1	None	None
2	QT 67.0Hz	QT 67.0Hz
3	QT 250.3Hz	QT 25.03Hz
4	DQT 023N	DQT 023N
5	None	2 Tone 321.7Hz/928.1Hz
6	DTMF (9)	DTMF (159)
7	MSK PN pattern	None
8	100Hz square wave	None
9	Tone 1 1633Hz	None

• LCD all lamp mode

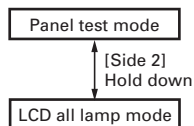

• Memory clear function

Pressing [PTT] while holding down [Orange] in Panel test mode, triggers the Memory clear function which clears all transceiver data settings.

• Panel tuning mode

Press [Side 1] in Panel test mode to set Panel tuning mode.

Note : Different sample displays are shown.

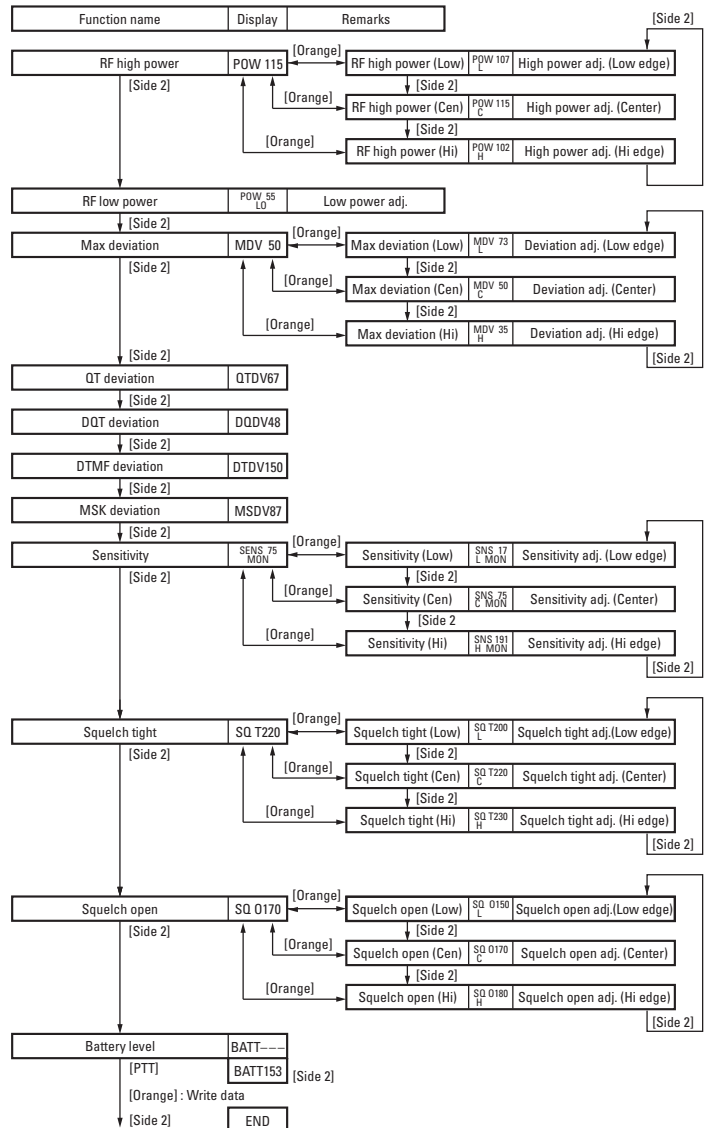

ADJUSTMENT

Common Section

Item	Condition	Measurement			Adjustment			Specifications/Remarks
		Test-equipment	Unit	Terminal	Unit	Parts	Method	
1. PLL lock voltage check RX	1) Set panel test mode CH No. : 2 Signalling No. : 1		Panel TX-RX	TP1			Check	1.0~1.6V
	2) Set panel test mode CH No. : 3 Signalling No. : 1							4.3V or less
SUB RX-Hi	3) Set panel tuning mode CH No. : 1 Signalling No. : 1			TP2				2.2~2.8V

Caution : When adjusting transmit power and sensitivity, connect the cable to the SMA antenna connector on the top panel. At this time, use the antenna-less type jig connector (E30-3287-08) in the universal connector.

Transmitter Section

Item	Condition	Measurement			Adjustment			Specifications/Remarks
		Test-equipment	Unit	Terminal	Unit	Parts	Method	
1. Frequency adjustment	1) Set panel test mode CH No. : 3 Signalling No. : 1 Select FRQ * * * in panel tuning mode PTT : ON	Power meter f. counter	Panel	ANT	Panel	TOP1/ TOP2	33.3000MHz :K 42.5000MHz :K2	±50Hz
2. Maximum power check	1) Set panel test mode CH No. : 3 Signalling No. : 1 BATT terminal voltage : 7.5V Select POW 255 in panel tuning mode PTT : ON	Power meter Ammeter	Panel	ANT			Check	6.3W or more
3. TX high power adjustment	1) Set panel test mode CH No. : 3 Signalling No. : 1 Select POW * * * in tuning mode Push Monitor to 3 point adjustment mode Select POW * * * L PTT : ON				Panel	TOP1/ TOP2	5.8W	±0.5W 2.3A or less
	2) Push Tone2 to select POW * * * M PTT : ON							
	3) Push Tone2 to select POW * * * H PTT : ON							

ADJUSTMENT

Item	Condition	Measurement			Adjustment			Specifications/Remarks
		Test-equipment	Unit	Terminal	Unit	Parts	Method	
4. TX high power check	1) Set panel test mode CH No. : 1 Signalling No. : 1 PTT : ON	Power meter	Panel	ANT			Check	5.5W or more 2.3A or less
	2) CH No. : 2 Signalling No. : 1 PTT : ON	Ammeter						
	3) CH No. : 3 Signalling No. : 1 PTT : ON							
5. TX low power adjustment	1) Set panel test mode CH No. : 3 Signalling No. : 1 Select POW * * * LO PTT : ON				Panel	TOP1/ TOP2	1.0W	±0.2W 1.4A or less
6. TX low power check	1) Set panel test mode CH No. : 1 Signalling No. : 1 Set low power (Push Side2) PTT : ON						Check	0.7W~1.3W 1.4A or less
	2) CH No. : 2 Signalling No. : 1 Set low power (Push Side2) PTT : ON							
	3) CH No. : 3 Signalling No. : 1 Set low power (Push Side2) PTT : ON							
7. DQT balance adjustment	1) Set panel test mode CH No. : 3 Signalling No. : 1 Select BLNC * * * in panel tuning mode Deviation meter filter setting LPF : 3kHz HPF : OFF PTT : ON	Power meter Deviation meter Oscilloscope	Panel	ANT	Panel	TOP1/ TOP2	Make the demodulation waves into square waves.	
		AG AF VTVM	Side	Universal				
8. Maximum deviation adjustment	1) Set panel test mode CH No. : 3 Signalling No. : 1 Select MDV * * * in panel tuning mode Push Monitor to 3 point adjustment mode Select MDV * * * L AG : 1kHz/150mV Deviation meter filter setting LPF : 15kHz HPF : OFF PTT : ON						3.95kHz (According to the larger +, -)	±50Hz

ADJUSTMENT

Item	Condition	Measurement			Adjustment			Specifications/Remarks
		Test-equipment	Unit	Terminal	Unit	Parts	Method	
8. Maximum deviation adjustment	2) Push Tone2 to select POW * * * M PTT : ON	Power meter Deviation meter Oscilloscope	Panel	ANT	Panel	TOP1/ TOP2	3.95kHz (According to the larger +, -)	±50Hz
	3) Push Tone2 to select POW * * * H PTT : ON	AG AF VTVM	Side	Universal				
9. MIC sensitivity check	1) Set panel test mode CH No. : 3 Signalling No. : 1 AG : 1kHz/10mV Deviation meter filter setting LPF : 15kHz HPF : OFF PTT : ON						Check	1.4kHz~2.9kHz
10. QT deviation adjustment	1) Set panel tuning mode CH No. : 3 Signalling No. : 1 MIC input : OFF Select QTDV * * * in panel tuning mode Deviation meter filter setting LPF : 3kHz HPF : 50Hz De-emphasis : 750μs PTT : ON				Panel	TOP1/ TOP2	0.75kHz	±0.05kHz
11. DQT deviation adjustment	1) Set panel test mode CH No. : 3 Signalling No. : 1 Select DQDV * * * in panel tuning mode Deviation meter filter setting LPF : 3kHz HPF : OFF PTT : ON						0.75kHz	±0.05kHz
12. DTMF deviation adjustment	1) Set panel test mode CH No. : 3 Signalling No. : 1 Select DTDV * * * in tuning mode Deviation meter filter setting LPF : 15kHz HPF : OFF PTT : ON						3.0kHz	±0.2kHz
13. MSK deviation adjustment	1) Set panel test mode CH No. : 3 Signalling No. : 1 Select MSDV * * * in panel tuning mode Deviation meter filter setting LPF : 15kHz HPF : OFF PTT : ON						3.0kHz	±0.2kHz

ADJUSTMENT

Item	Condition	Measurement			Adjustment			Specifications/Remarks
		Test-equipment	Unit	Terminal	Unit	Parts	Method	
14. Transmission S/N check	1) Set panel test mode CH No. : 3 Signalling No. : 1 Deviation meter filter setting LPF : 300Hz HPF : 3kHz De-emphasis : 750μs PTT : ON	Power meter Deviation meter Oscilloscope AG AF VTVM	Panel Side	ANT Universal			Check	42dB or more
15. BATT detection writing	1) Set panel test mode CH No. : 3 Signalling No. : 1 Select BATT * * * in panel tuning mode PTT : ON	Power meter DC VTVM	Panel Bottom	ANT BATT terminal	Side	Monitor	Write the voltage level	6.2V
16. BATT detection check	1) Set panel test mode CH No. : 3 Signalling No. : 1 BATT terminal voltage : 5.3V PTT : ON						Check	Cannot transmit LED (TX) blinks
	2) BATT terminal voltage : 6.5V PTT : ON							Transmit

Receiver Section

Item	Condition	Measurement			Adjustment			Specifications/Remarks
		Test-equipment	Unit	Terminal	Unit	Parts	Method	
1. AF level check	1) Set panel test mode CH No. : 3 Signalling No. : 1 SSG freq. : Each freq. output : -53dBm/501μV MOD. : 1kHz DEV. : 2.4kHz	SSG AF VTVM Oscilloscope Distortion meter Audio analyzer	Panel	ANT			Check	0.55V±0.3V (VOL.2) 5% or less
2. Hum and noise ratio check	1) Set panel test mode CH No. : 3 Signalling No. : 1 SSG output : -53dBm/501μV							42dB or more
3. BPF coil Use this adjustment procedure after replacing any of the BPF coils	1) Set panel test mode CH No. : 1 Connect the spectrum analyzer to TP3 Signalling No. : 1 Push Monitor to 3 point adjustment mode Select SNS 75 M	Tracking generator Spectrum analyzer	Panel TX-RX	ANT TP3	TX-RX	L201 L202 L206	Adjust the BPF coil so that the waveform is peaked. The frequency with the peak waveform does not have to be the center frequency. After finished peaking the waveform, perform a 3 point adjustment and set for maximum sensitivity.	

Fig. 1 :K

ADJUSTMENT

Item	Condition	Measurement			Adjustment			Specifications/Remarks
		Test-equipment	Unit	Terminal	Unit	Parts	Method	
3. BPF coil		Tracking generator Spectrum analyzer	Panel TX-RX	ANT TP3	TX-RX	L201 L202 L206	 <p>Fig. 1 :K2</p>	
4. MCF adjustment Use this adjustment procedure after replacing any of the MCF coils.	1) Set panel test mode CH No. : 1 Signalling No. : 1	Tracking generator Spectrum analyzer	Panel TX-RX	TP10 TP11	TX-RX	L302 L303 L304	<p>Adjust the coil so that it becomes the Spectrum waveform shown in Fig. 2.</p>  <p>Fig. 2</p>	
5. Sensitivity adjustment and check	1) Set panel test mode CH No. : 3 Signalling No. : 1 Select SNS *** in panel tuning mode Push Monitor to 3 point adjustment mode Select SNS *** L SSG freq. : Low output : -116dBm/0.35μV 2) Push Tone2 to select SNS *** M SSG freq. : Center 3) Push Tone2 to select SNS *** H SSG freq. : Hi	SSG AF VTVM Oscilloscope Distortion meter Audio analyzer	Panel Side	ANT Universal	Panel	TOP1/ TOP2	Adjust for maximum SINAD	12dB SINAD or more
6. Tight squelch adjustment	1) Set panel test mode CH No. : 3 Signalling No. : 1 Select SQ T *** in panel tuning mode SSG output : 6dB above to 12dB SINAD level						Adjust to point of opening squelch	

ADJUSTMENT

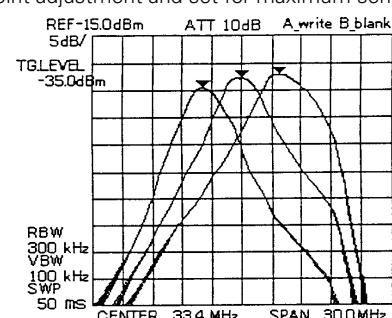
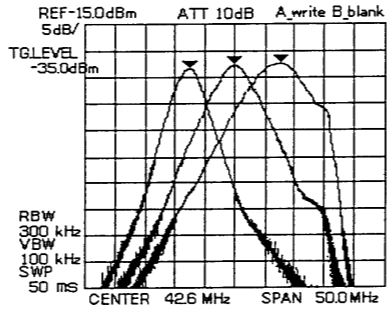
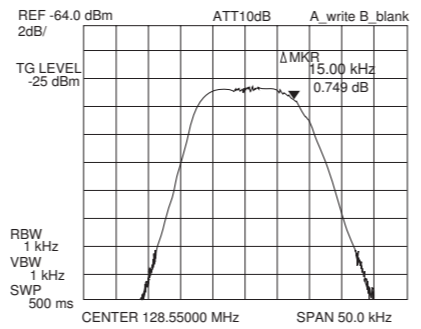
Item	Condition	Measurement			Adjustment			Specifications/Remarks
		Test-equipment	Unit	Terminal	Unit	Parts	Method	
7. Squelch adjustment	1) Set panel test mode CH No. : 3 Signalling No. : 1 Select SQ O *** in panel tuning mode SSG output : 3dB below to 12dB SINAD level	SSG AF VTVM Oscilloscope Distortion meter analyzer	Panel Side	ANT Universal	Panel	TOP1/ TOP2	Adjust to point of opening squelch	
8. Squelch check	1) Set panel test mode CH No. : 3 Signalling No. : 1 SSG output : -118dBm/0.28μV 2) SSG output : -127dBm						Check	Squelch must be opened Squelch must be closed

Adjustment Point

■ Foil side

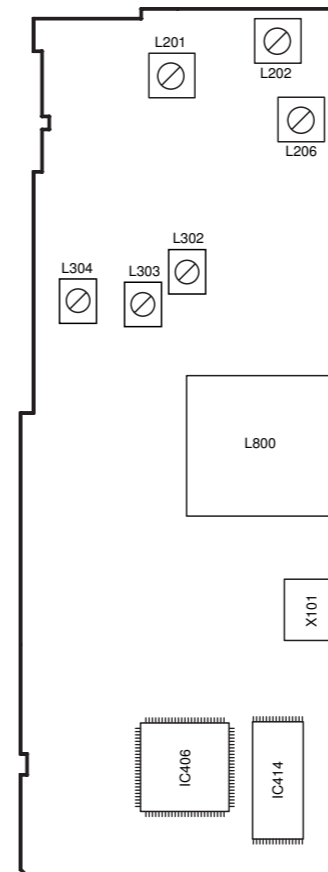

■ Component side

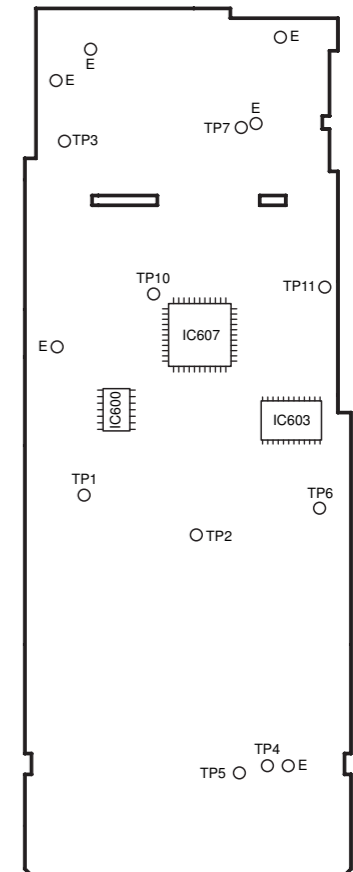

TK-190 PC BOARD VIEWS

FINAL UNIT (X45-3610-10) Component Side View

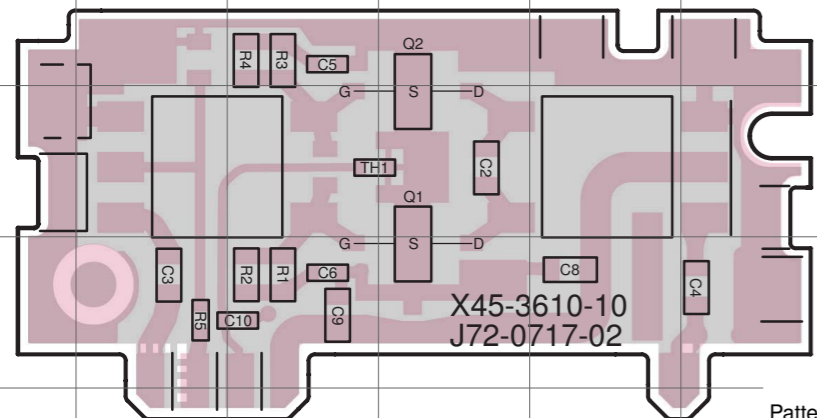

X45-3610-10
J72-0717-02

FINAL UNIT
(Component side)

Ref No.	Address
Q1	3D
Q2	2D

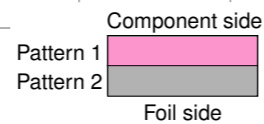

CONTROL UNIT (X53-3930-10 B/6,D/6,E/6,F/6) Component Side View

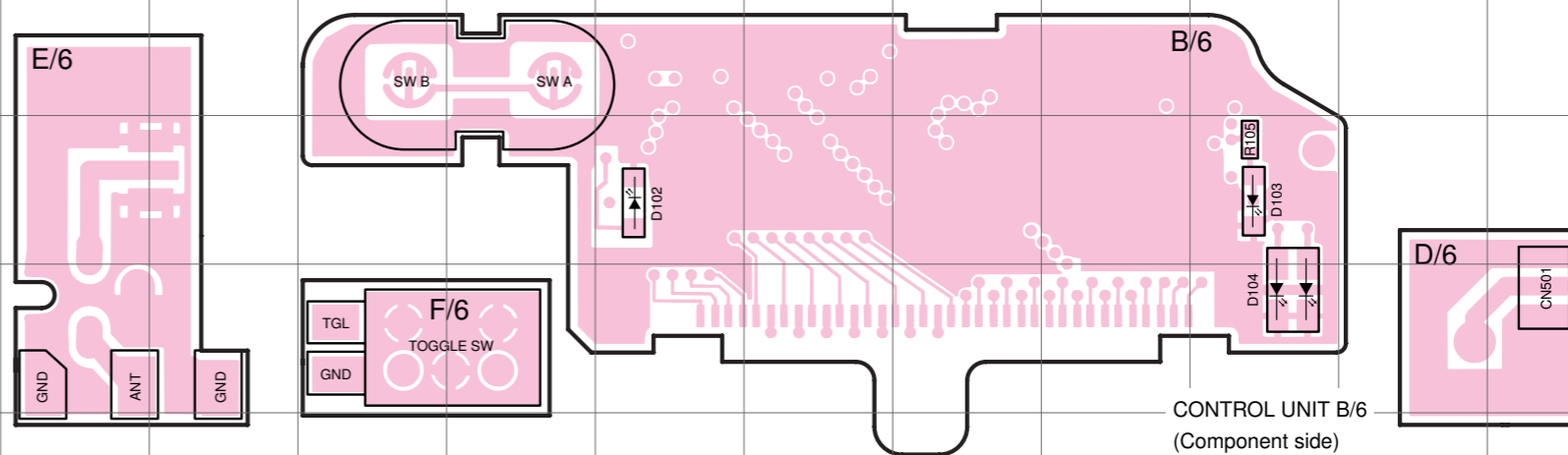

CONTROL UNIT B/6
(Component side)

Ref No.	Address
D102	3M
D103	3Q
D104	4Q

CONTROL UNIT (X53-3930-10 A/6) Component Side View

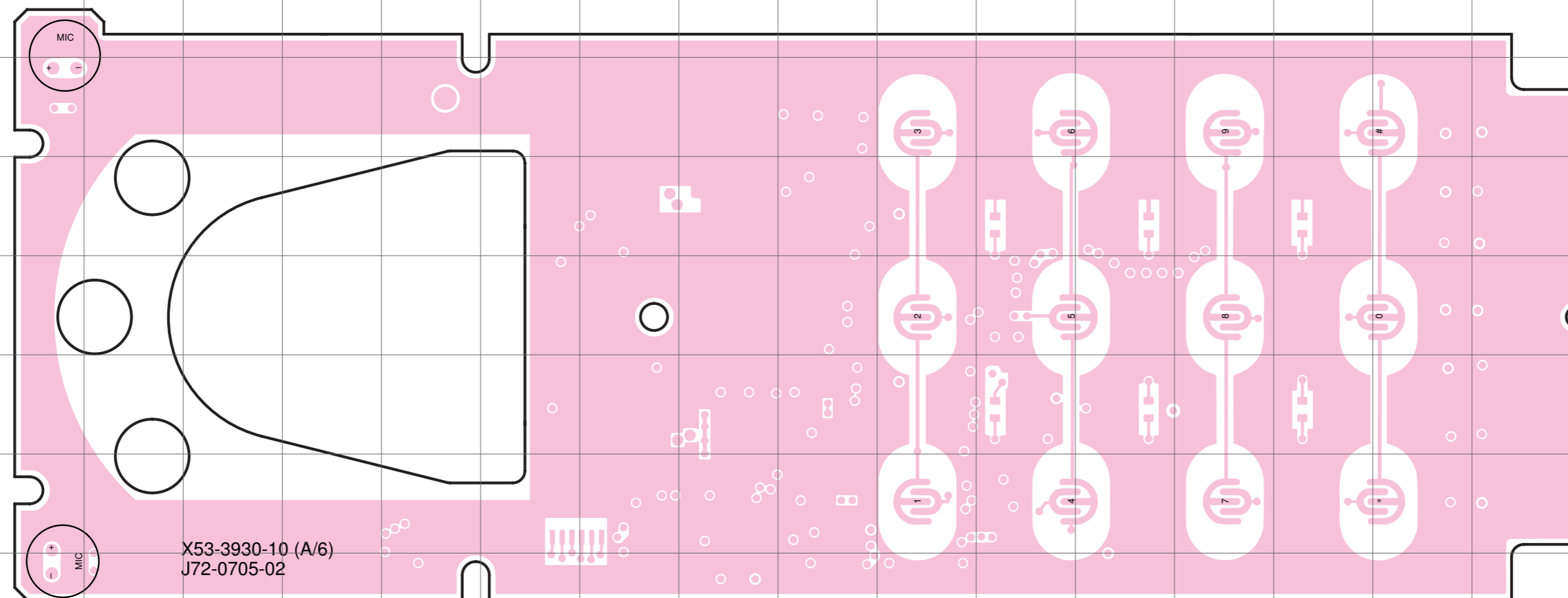

X53-3930-10 (A/6)
J72-0705-02

2SK3075

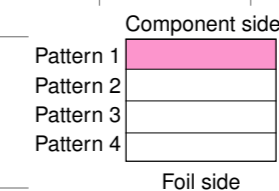
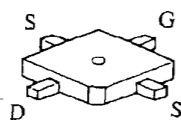

PC BOARD VIEWS TK-190

CONTROL UNIT (X53-3930-10 B/6,D/6,E/6,F/6) Foil Side View

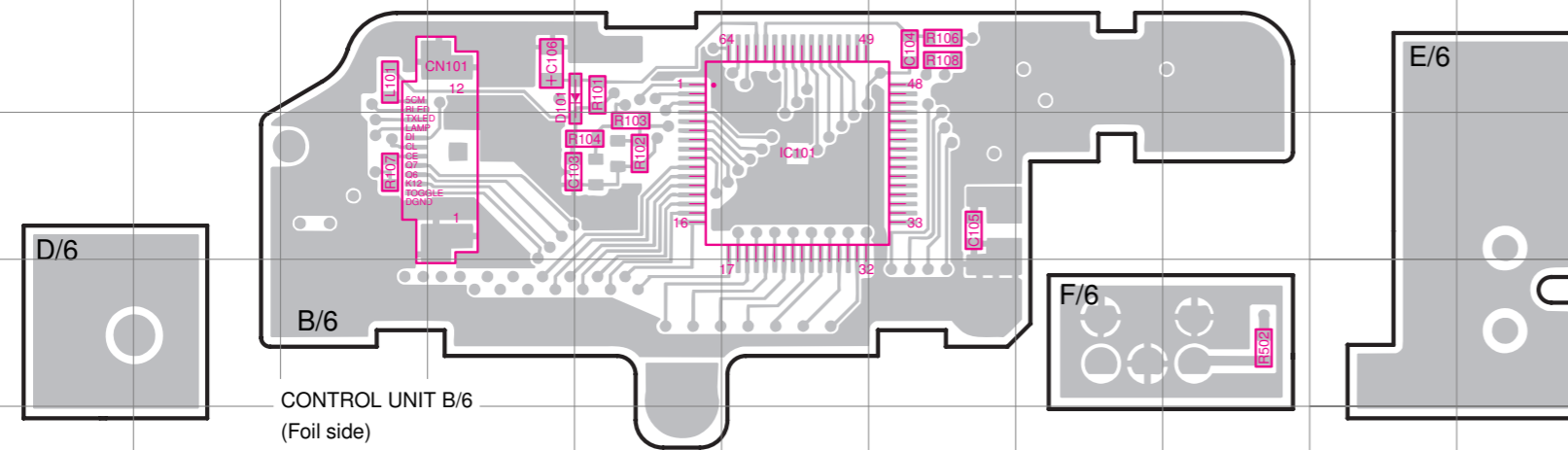

CONTROL UNIT B/6
(Foil side)

Ref.No.	Address
IC101	3F
D101	2E

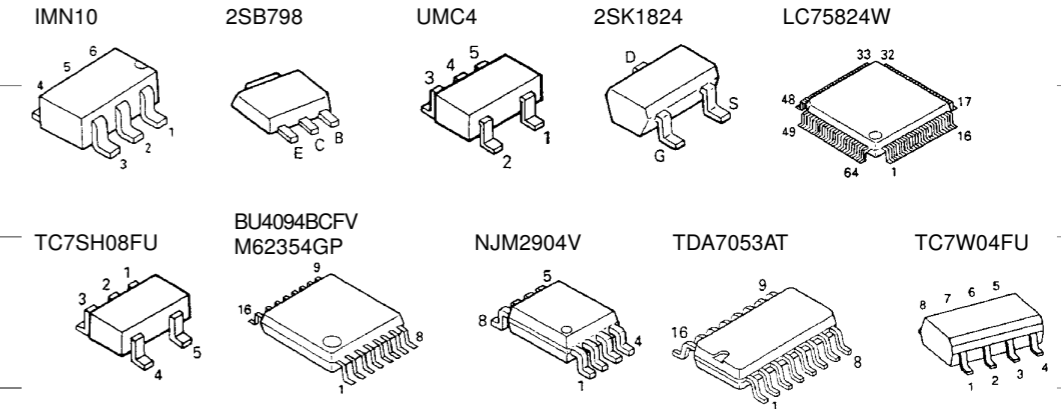

CONTROL UNIT (X53-3930-10 A/6) Foil Side View

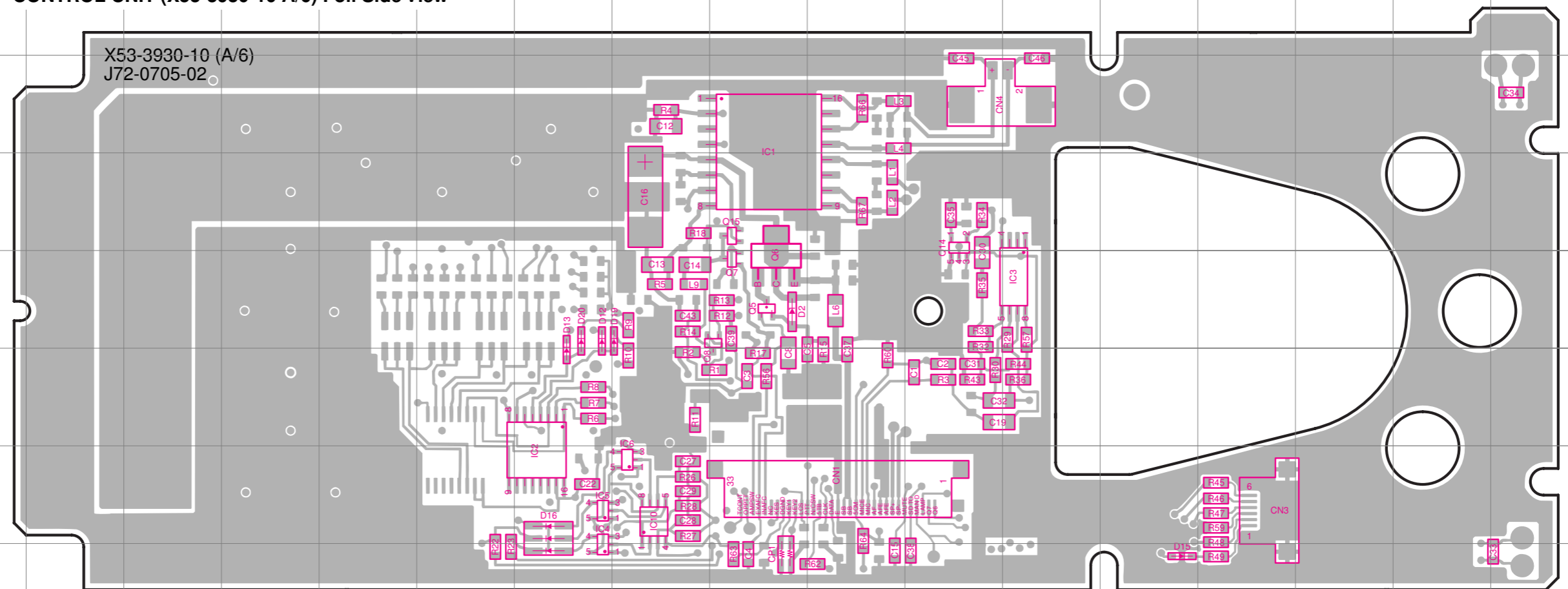

CONTROL UNIT A/6
(Foil side)

Ref.No.	Address	Ref.No.	Address	Ref.No.	Address	Ref.No.	Address
IC1	7J	IC6	11I	Q8	9J	D13	10H
IC2	11H	IC10	11I	Q14	8L	D15	12N
IC3	9M	Q5	9J	Q15	8J	D16	11H
IC4	12H	Q6	9J	D2	9J	D19	9H
IC5	11H	Q7	9J	D12	9H	D20	9H

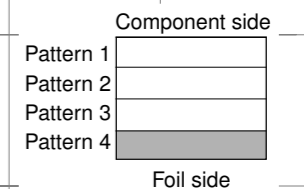

TX-RX UNIT (X57-608X-XX) 0-10:K,0-11:K2 Foil Side View

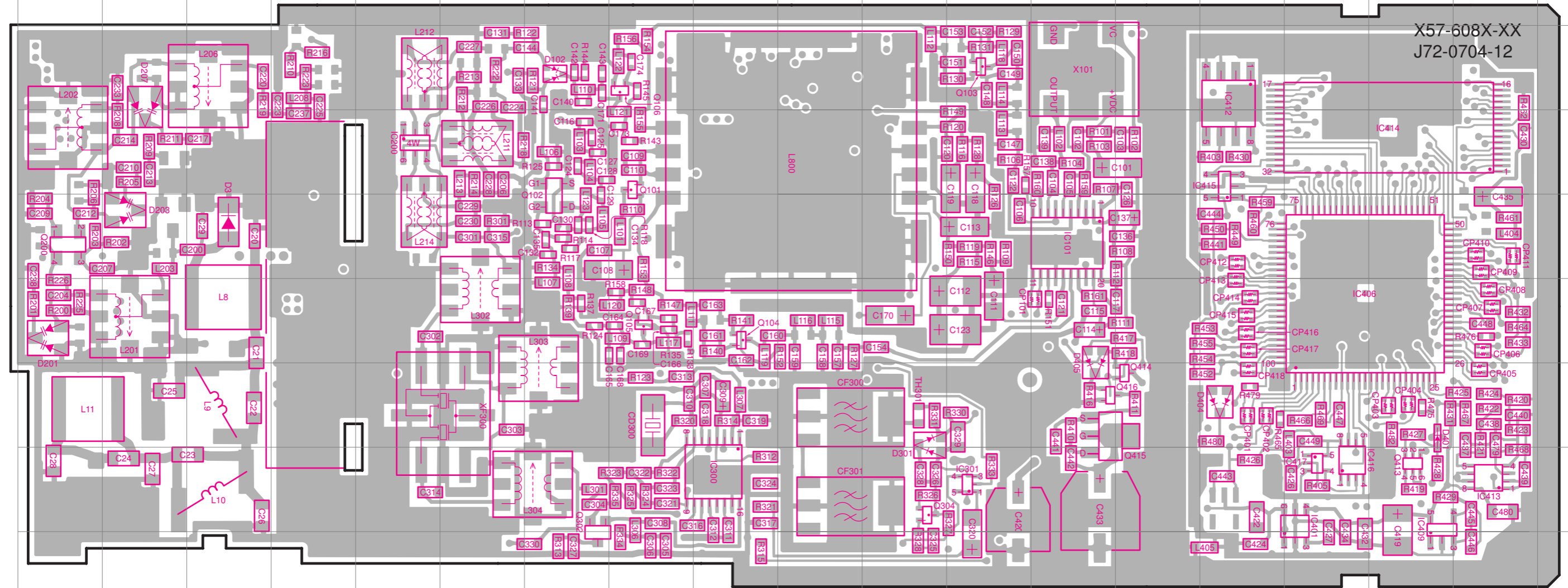

TX-RX UNIT
(Foil side)

Ref.No.	Address	Ref.No.	Address	Ref.No.	Address
IC101	5M	IC417	8P	Q415	7M
IC200	4E	Q101	4H	D3	5C
IC300	8I	Q102	4G	D102	3G
IC301	8L	Q103	3L	D201	6A
IC401	8P	Q104	6I	D203	5B
IC406	6P	Q105	6H	D207	3B
IC409	8Q	Q106	3H	D301	8K
IC412	3O	Q200	5A	D401	7Q
IC413	8R	Q302	9G	D404	7O
IC414	4Q	Q304	8K	D405	7M
IC415	4O	Q413	8Q		
IC416	8P	Q414	7N		

TK11250BM

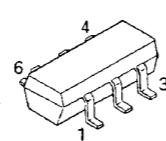

TC704FU
TC7S66FU

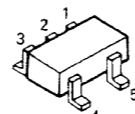

AT2408N10SI2.5

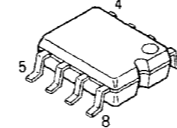

TC35453F

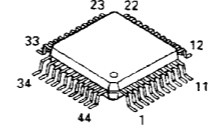

GN2011

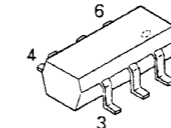

TC7S02F

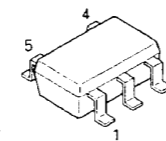

HN1L02FU

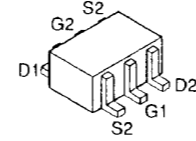

3SK131

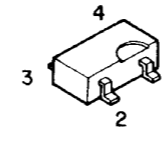

BU4094BCFV
M62354GP

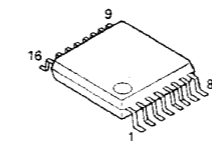

MAX856
NJM2904V

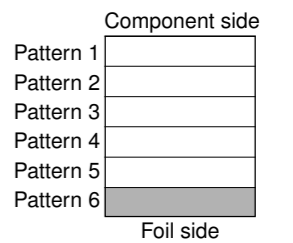
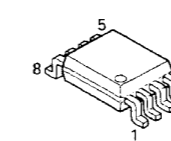

TK-190 PC BOARD VIEWS

TX-RX UNIT (X57-608X-XX) 0-10:K,0-11:K2 Component Side View + Foil Side View

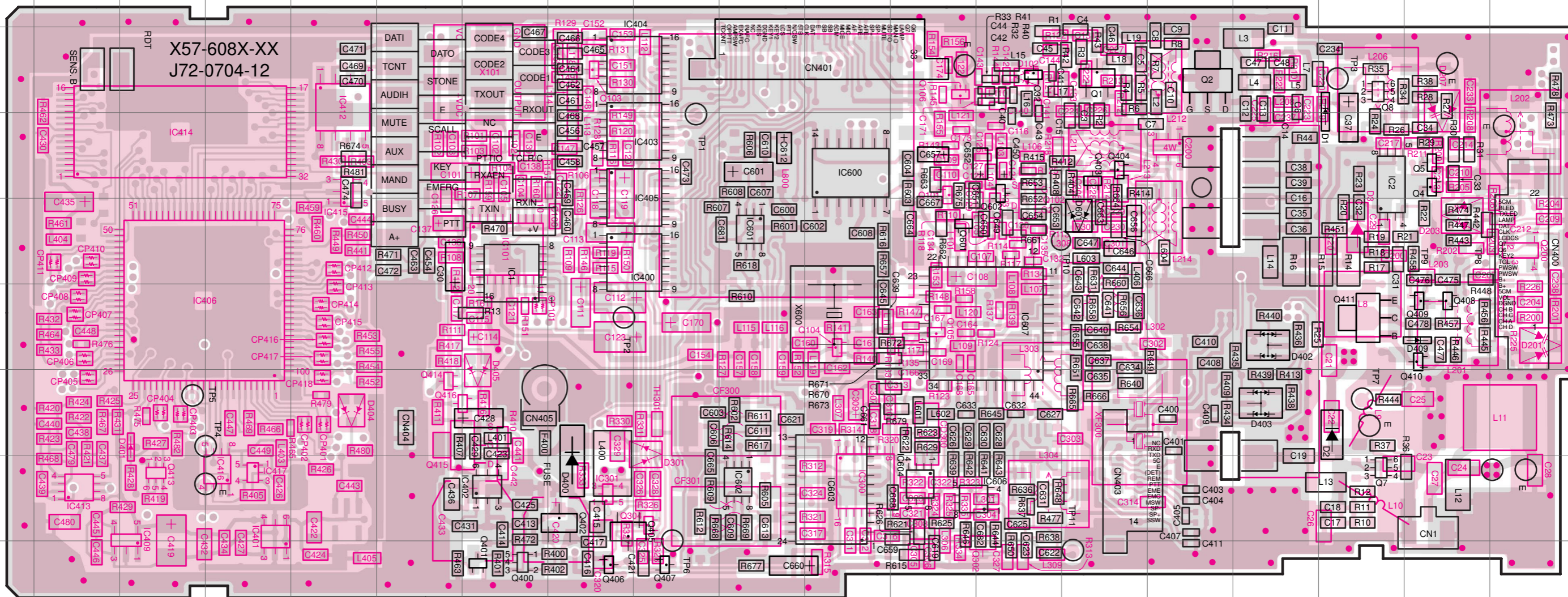

TX-RX UNIT
(Component side) + (Foil side)

Ref.No.	Address	Ref.No.	Address	Ref.No.	Address	Ref.No.	Address	Ref.No.	Address
IC1	5G	IC414	4C	Q8	3Q	Q405	8I	D102	3M
IC2	4Q	IC415	4E	Q32	3M	Q406	9H	D201	6S
IC101	5G	IC416	8D	Q101	5L	Q407	9I	D203	5R
IC200	4O	IC417	8D	Q102	5M	Q408	6R	D207	3R
IC300	8K	IC600	4K	Q103	3H	Q409	6R	D301	8I
IC301	8H	IC601	5J	Q104	6K	Q410	6R	D400	8H
IC400	5I	IC602	8J	Q105	6L	Q411	6Q	D401	7C
IC401	9D	IC603	8K	Q106	3L	Q413	8C	D402	6P
IC402	8G	IC604	8L	Q200	5S	Q414	7F	D403	7P
IC403	4I	IC606	8M	Q302	9M	Q415	7F	D404	7E
IC404	3I	IC607	6M	Q304	8I	Q416	7G	D405	7G
IC405	4I	Q1	3N	Q400	9G	Q601	5L	D409	6R
IC406	6C	Q2	3O	Q401	9G	Q602	4M	D601	5N
IC409	9C	Q4	4R	Q402	8H	D1	3Q		
IC412	3E	Q5	4R	Q403	4N	D2	7Q		
IC413	8B	Q7	8Q	Q404	4N	D3	5Q		

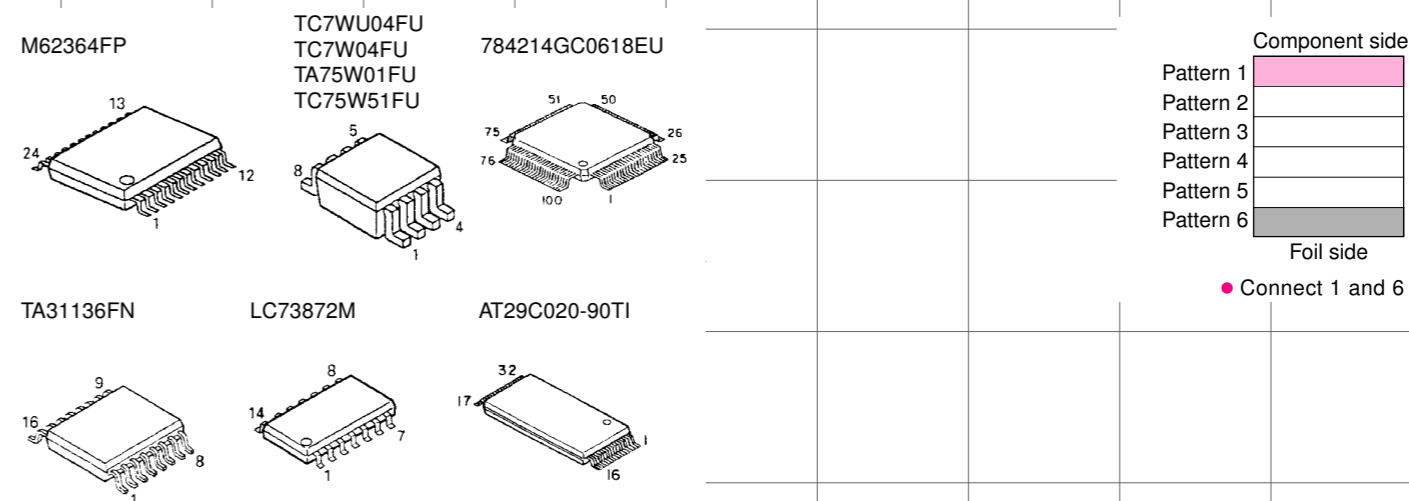

SCHEMATIC DIAGRAM TK-190

X57-608X-XX TX-RX UNIT

IC1	MS23549P	IC300	TA31136FN	IC406	784214G0648EU	IC414	AT29C020-90T1	IC600	LC73872M	Q1	2SC3356 (R23)	Q7, B	413	HN1L02FU	Q104, 105	2SC4617 (R)	Q403	2SJ243	Q411	2SB1132 (G, R)	D1	DTZ4.3 (A)	D301, 601	MA742	D404, 405	15S301
IC2	NUM2904V	IC301	TC7566FU	IC409	PS19132NR	IC415	TC7502F	IC602	TA75901FU	Q2	2SK3074	Q3B, 103, 106		2SC4649 (N, P)	Q404	2SK1215 (E)	Q404	DTL144EE	Q415	2SJ517	D2, 3	Q302	15R154-400	D400	15R154-400	
IC101	LMX232LTMX	IC400, 403-405	BU40948CFV	IC412	AT240N10S12.5	IC416	TC7ML04FU	IC603	MS2364FP	Q4	DTC114EE	Q101, 304, 40B-410		2SC4617 (S)	Q400	UMC3N	Q405	DTB123YK	D102	DAN235E	D401, 409	MA2S111	D402, 403	NNCDE.66		
IC200	GN2011 (G)	IC401, 402	TK112608M	IC413, 601, 604, 605	TC75W51FU	IC417	TC7304FU	IC607	TC35453F	Q5, 401, 414, 416, 601, 602		2SK1824	Q102, 200	3SK131 (L)	Q402	2SA1362 (Y)	Q406, 407	DTA123.E	D201, 203, 207	KV1460	D402, 403	NNCDE.66				

L10	L34-4616-05	L201	566	L16	566	C6	10000	C19	880	C20	566	C22	880	C23	120	C24	1000	C25	1500	C26	1500	C27	1000	C28	820	C29	560	R2	15	R4	270	R5	18	R6	270	
0-10	K	L2	34-4623-05	R21	470	0.01u	390	Z7D	470	90	566	820	820	560	680	100	15	150	39	150																

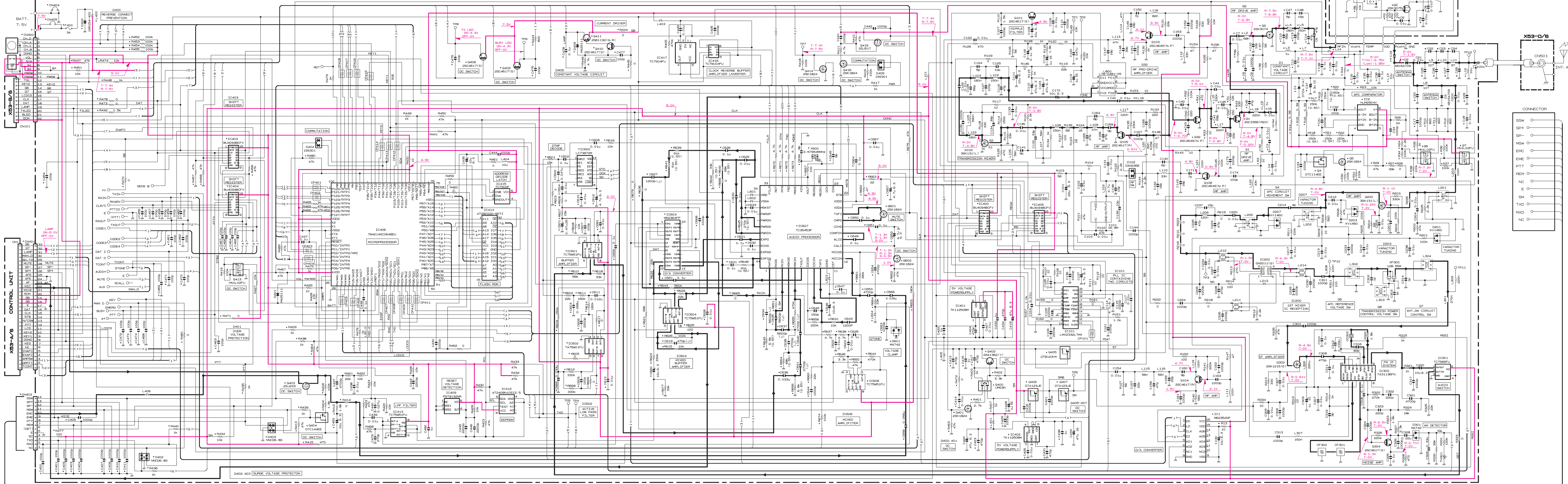

X55-B/6

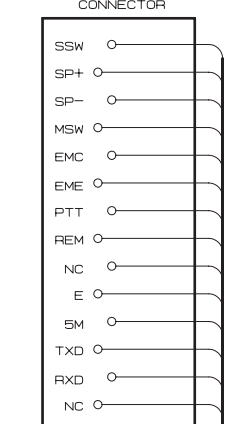

X55-A/B

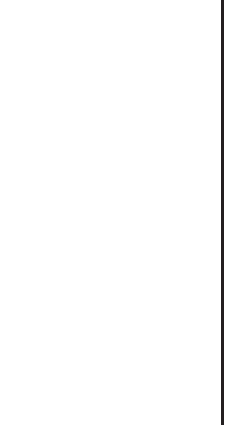

CONNECTOR

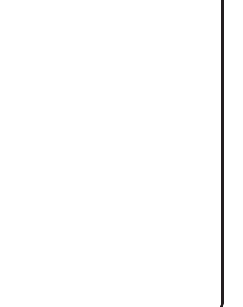

TK-190 SCHEMATIC DIAGRAM

IC1 : TDA7053AT	IC10 : TC7W04FU	Q5 : 2SC4617(S)	D2 : DTZ3.9(B)	D102, 103 : B30-2190-05
IC2 : BU4094BCFV	IC101 : LC75824W	Q6 : 2SB798(DL,DK)	D12, 13, 15, 19, 20 : MA2S111	D104 : B30-2019-05
IC3 : NJM2904V		Q7, 8, 15 : 2SK1824	D16 : 1MN10	
IC4-6 : TC7SH08FU		Q14 : UMC4	D101 : 1SS373	

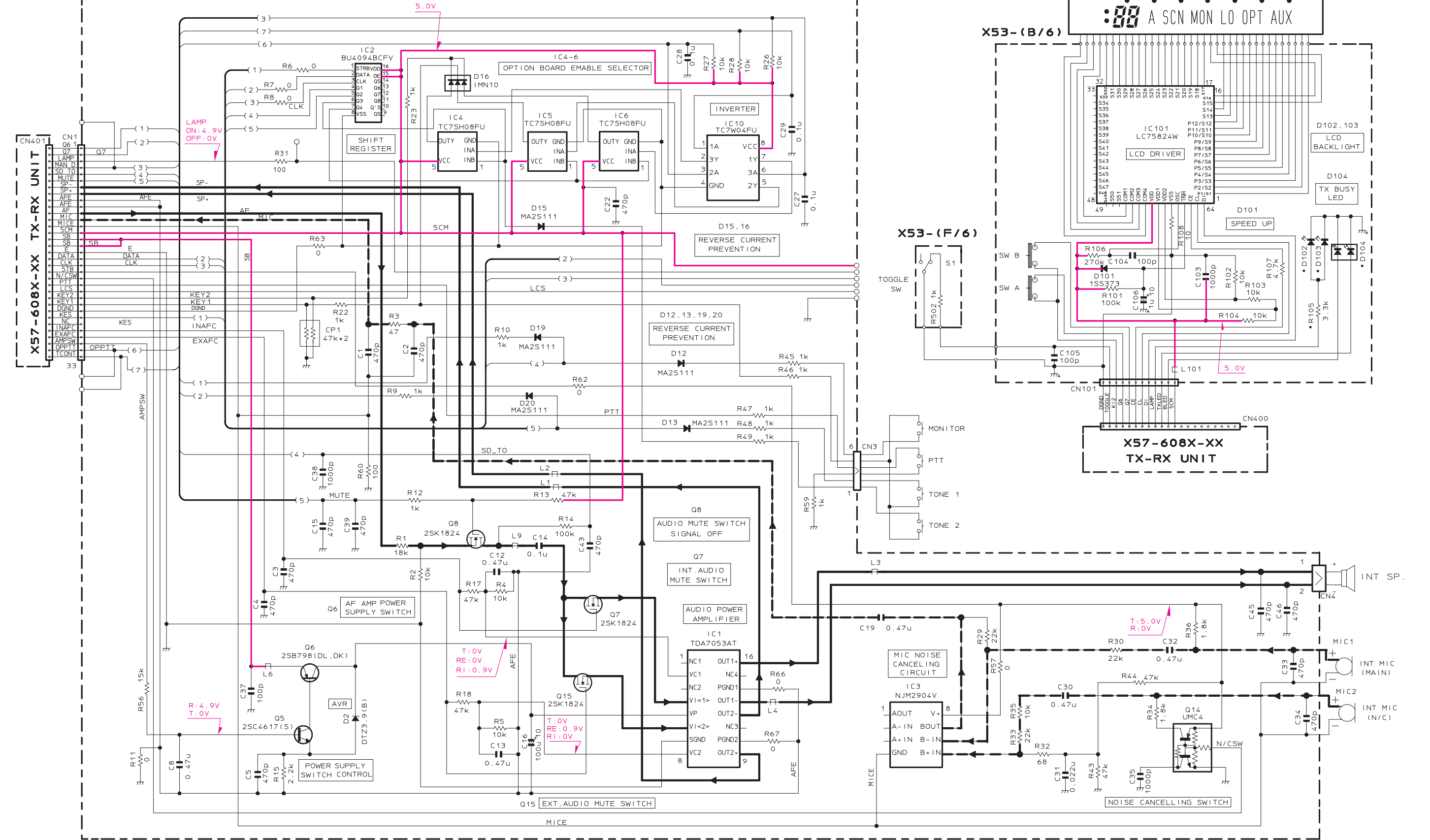

LEVEL DIAGRAM

Receiver Section

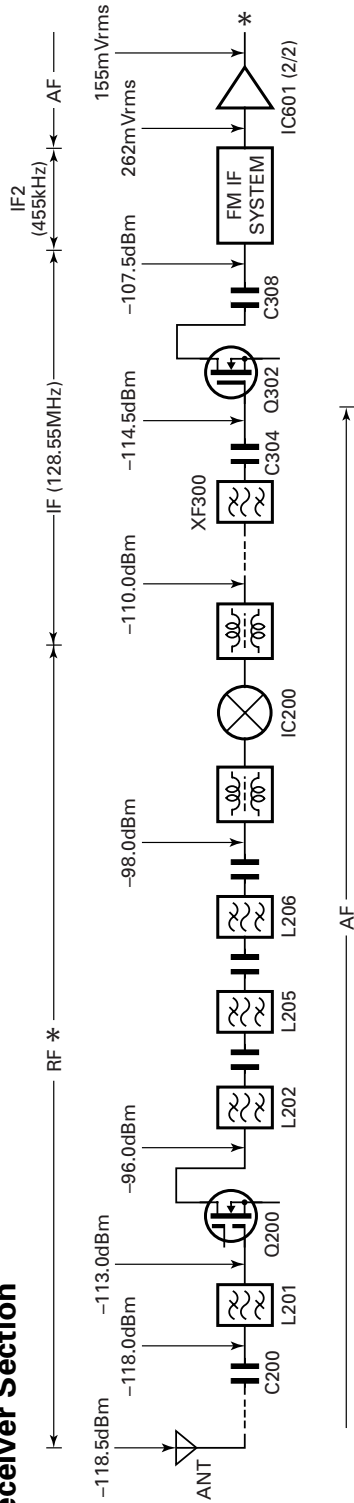

To make measurements in the AF section, connect the AC level meter. (ANT input : -53dBm, 1kHz FM, 3kHz DEV.)
In the RF section, use a 10000pF coupling capacitor. (The display shows the SSG input value required to obtain 12dB SINAD.)

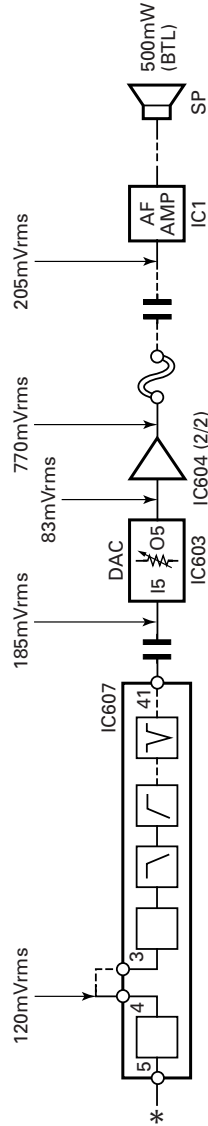

Transmitter Section

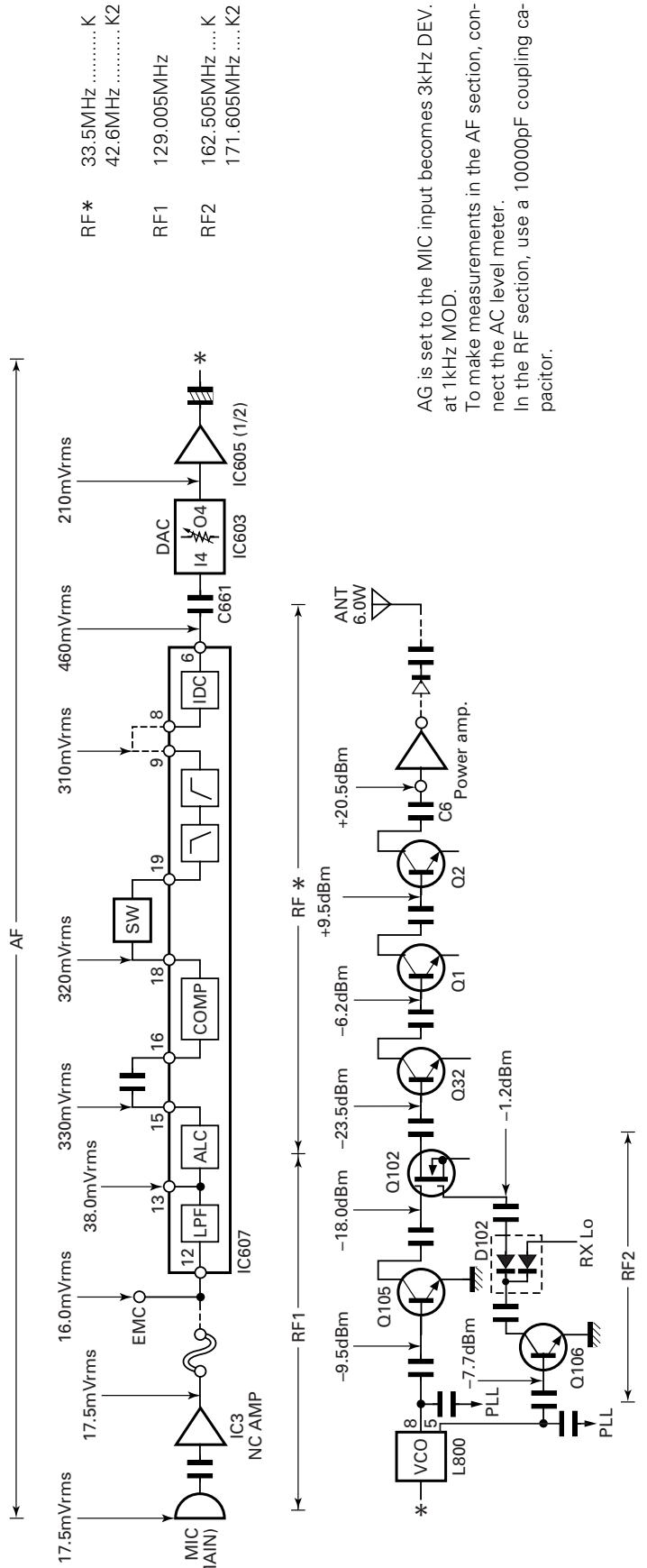

AG is set to the MIC input becomes 3kHz DEV.
To make measurements in the AF section, connect the AC level meter.
In the RF section, use a 10000pF coupling capacitor.

RF *	33.5MHz K
	42.6MHz K2
RF1	129.005MHz
RF2	162.505MHz K
	171.605MHz K2

TERMINAL FUNCTION

CN No.	Pin No.	Name	I/O	Function	CN No.	Pin No.	Name	I/O	Function	
TX-RX UNIT (X57-608X-XX)										
CN400 to X53 (CN101)	1	CH D	I	CH switch data.	26 27 28 29 30 31 32 33		SP+	I	BTL input + for external speaker.	
	2	CH A	I	CH switch data.			SP-	I	BTL input - for external speaker.	
	3	CH C	I	CH switch data.			MUTE	-	Audio mute switch.	
	4	CH B	I	CH switch data.			SD TO	O	Optional board enable.	
	5	DGND	-	Digital ground			MAN D	O	Optional board enable.	
	6	VOL	I	Volume voltage level input for audio control.			LAMP	O	Backlight LED control. Normally : 0V, Lighting : 7.5V	
	7	5CM	-	5V.			Q7	O	Key scan signal Q7.	
	8	B+	-	Power input after passing through the fuse.			Q6	O	Key scan signal Q8.	
	9	B+	-	Power input after passing through the fuse.		CN403 X57 for uni- versal con- nector	1	NC	-	Not connect.
	10	PWSW	-	Power output after power switch.			2	RXD	I	Serial data input.
	11	PWSW	-	Power output after power switch.			3	TXD	O	Serial data output.
	12	TGL	I	Toggle switch output. Normally : 5V, switched : 0V			4	5CM	-	5V.
	13	KEY2	I	Key scan sense KEY2.			5	E	-	GND
	14	Q6	O	Key scan signal.			6	NC	-	Non connect.
	15	Q7	O	Key scan signal.	7		REM	I	Programmable function key input.	
	16	LCDCS	O	LCD driver IC enable.	8		PTT	I	External PTT input.	
	17	CLK	O	LCD driver IC clock.	9		EME	-	External microphone GND.	
	18	DAT	O	LCD driver IC data.	10		EMC	I	External microphone input.	
	19	LAMP	-	Backlight LED control. Normally : 0V, Lighting : 7.5V	11	MSW	I	EXT/INT MIC switch input.		
	20	TXLED	-	TX LED control. Normally : 0V, Lighting : 7.5V	12	SP-	O	BTL output - for external speaker.		
	21	BLED	-	Busy LED control. Normally : 0V, Lighting : 7.5V	13	SP+	O	BTL output + for external speaker.		
	22	5CM	-	5V.	14	SSW	I	EXT/INT speaker switch input.		
					CONTROL UNIT (X53-3930-10) (A/6)					
CN401 to X53(A/6) (CN1)	1	TCONT	O	Optional board enable.	CN1 to X57 (CN401)	1	Q6	O	Key scan signal Q6.	
	2	OPPTT	O	Optional board enable.		2	Q7	O	Key scan signal Q7.	
	3	AMPSW	O	Audio AMP control switch output.		3	LAMP	I	Backlight LED control. Normally : 0V, Lighting : 7.5V	
	4	EXTAFC	O	External speaker switch.		4	MAN D	I	Optional board enable.	
	5	INTAFC	O	Internal speaker switch.		5	SD TO	I	Optional board enable.	
	6	NC	-	Non connect.		6	MUTE	I	Audio mute switch.	
	7	KES	O	Key scan IC enable.		7	SP-	O	BTL output - for external speaker.	
	8	DGND	-	Digital ground.		8	SP+	O	BTL output + for external speaker.	
	9	KEY1	O	Key scan input.		9	AFE	-	Audio GND.	
	10	KEY2	O	Key scan input.		10	AFE	-	Audio GND.	
	11	LCS	O	LCD driver IC enable.		11	AF	I	Audio signal output.	
	12	PTT	O	PTT switch.		12	MIC	O	MIC signal input.	
	13	N/CSW	O	Noise canseler microphone switch.		13	MICE	-	MIC GND.	
	14	5TB	-	5V.		14	5CM	-	5V.	
	15	CLK	O	Clock line.		15	SB	-	Power output after power switch.	
	16	DAT	O	Data line.		16	SB	-	Power output after power switch.	
	17	E	-	GND.		17	E	-	GND.	
	18	SB	-	Power output after power switch.		18	DATA	I	Data line.	
	19	SB	-	Power output after power switch.		19	CLK	I	Clock line.	
	20	5CM	-	5V.		20	5TB	-	-5V	
	21	MICE	-	MIC GND.		21	N/CSW	I	Noise canseler microphone switch input.	
	22	MIC	I	MIC signal.		22	PTT	O	PTT switch.	
	23	AF	O	Audio signal.		23	LCS	I	LCD driver IC enable.	
	24	AFE	-	Audio GND.		24	KEY2	I	Scan input KEY2.	
	25	AFE	-	Audio GND.		25	KEY1	I	Scan input KEY1.	
				26	DGND	-	Digital ground.			
				27	KES	I	Key scan IC enable input.			

TERMINAL FUNCTION / KNB-17A (Ni-Cd BATTERY)

CN No.	Pin No.	Name	I/O	Function
CN1 to X57 (CN401)	28	NC	-	Non connect.
	29	INAFc	I	Internal speaker switch input.
	30	EXTAFc	I	External speaker switch input.
	31	AMPsw	I	Audio amplifier switch.
	32	OPPTT	I	Optional board enable.
	33	TCONT	I	Optional board enable.
CN3 to FPC	1	Q8	O	Key scan signal Q8.
	2	Q7	O	Key scan signal Q7.
	3	PTTE	-	PTT GND.
	4	PTT	I	PTT signal input Normally : 5V, Transmit : 0V.
	5	KI1	I	Key scan sense KEY1.
	6	Q6	O	Key scan signal.
CN4	1	+	O	BTL + output for internal speaker.
	2	-	O	BTL - output for internal speaker.
CONTROL UNIT (X53-3930-10) (B/6)				
CN101 to X57 (CN400)	1	DGND	-	Digital ground.
	2	TOGGLE	O	Taggle switch.
	3	KI2	O	Key sense KI1.
	4	Q6	I	Key scan signal.
	5	Q7	I	Key scan signal.
	6	CE	I	LCD driver IC enable.
	7	CL	I	LCD driver IC clock.
	8	DI	I	LCD driver IC data.
	9	LAMP	I	Backlight LED control. Normally : 0V, Lighting : 7.5V
	10	TX LED	I	TX LED switch. Normally : 0V, Lighting : 7.5V
	11	BLED	I	Busy LED switch. Normally : 0V, Lighting : 7.5V
	12	5CM	-	Mic ground.

KNB-17A External View



KNB-17A Circuit Diagram

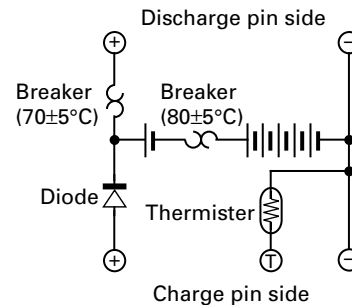

KNB-17A Specifications

Voltage	7.2V (1.2V x 6)
Charging current	1500mAh
Dimensions (mm)	58.0 W x 110.8 H x 20.0 D (Projections included)
Charger and charging time	
KSC-19 (Normal Charger)	Approx. 8 hours
KSC-20 (Rapid charger)	Approx. 1.3 hour
Weight	220g

KSC-19 (CHARGER) / KSC-20 (RAPID CHARGER) / KPG-36 (PROGRAMMING INTERFACE CABLE)

KSC-19 External View



KPG-36 External View



KSC-19 Charging

KNB-17A	
Voltage	7.2V
Battery capacity	1500mAh
Charging time	Approx. 8 hours

KSC-20 External View



KBP-4 External View

Battery case for 6x2 AA Alkaline Batteries



KSC-20 Specifications

Charging current	1100mA±150mA
Charging time	KNB-17A : 80 min.±24%
Source voltage	Approx 15V
Ambient temperature	0°C~40°C
Dimensions	105 W x 135 D x 52 H (mm)
Weight	0.18kg

TK-190

SPECIFICATIONS

GENERAL

Frequency Range	29.7 to 37.0MHz (K), 35.0 to 50.0MHz (K2)
Number of Channels	Max. 16 channels
Channel Spacing	20kHz / 25kHz
PLL Step	5kHz
Operating Voltage	7.5V DC
Battery Life	9 hours at 6 watts (5-5-90 duty cycle with KNB-17A battery)
Operating Temperature range	-30°C to +60°C (-22°F to +140°F)
Dimensions and Weight	
With KNB-17A (7.2V 1500mAh battery)	58 (2-5/16) W x 155 (6-3/32) H x 38 (1-1/2) D mm (in)
	600g

RECEIVER (Measurements made per EIA/TIA-603)

Sensitivity	
EIA 12dB SINAD	0.25 μ V
Selectivity	70dB
Intermodulation	65dB
Spurious response	70dB
Audio Power Output	500mW
Frequency Stability	\pm 5ppm
Channel Frequency Spread	7.3MHz (K), 15MHz (K2)

TRANSMITTER (Measurements made per EIA/TIA-603)

RF Power Output	6W / 1W
Spurious Harmonics	55dB/60dB
Modulation	16K ϕ F3E (Wide)
FM Noise	45dB
Audio Distortion	Less than 3%
Frequency Stability	\pm 5ppm
Channel Frequency Spread	7.3MHz (K), 15MHz (K2)

KENWOOD CORPORATION

14-6, Dogenzaka 1-chome, Shibuya-ku, Tokyo 150-8501, Japan

KENWOOD SERVICE CORPORATION

P.O. BOX 22745, 2201 East Dominguez Street, Long Beach, CA 90801-5745, U.S.A.

KENWOOD ELECTRONICS CANADA INC.

6070 Kestrel Road, Mississauga, Ontario, Canada L5T 1S8

KENWOOD ELECTRONICS DEUTSCHLAND GMBH

Rembrücker Str. 15, 63150 Heusenstamm, Germany

KENWOOD ELECTRONICS BELGIUM N.V.

Mechelsesteenweg 418 B-1930 Zaventem, Belgium

KENWOOD ELECTRONICS FRANCE S.A.

13, Boulevard Ney, 75018 Paris, France

KENWOOD ELECTRONICS U.K. LIMITED

KENWOOD House, Dwight Road, Watford, Herts., WD1 8EB United Kingdom

KENWOOD ELECTRONICS EUROPE B.V.

Amsterdamseweg 37, 1422 AC Uithoorn, The Netherlands

KENWOOD ELECTRONICS ITALIA S.p.A.

Via G. Sirtori, 7/9 20129 Milano, Italy

KENWOOD IBERICA S.A.

Bolivia, 239-08020 Barcelona, Spain

KENWOOD ELECTRONICS AUSTRALIA PTY. LTD.

(A.C.N. 001 499 074)

16 Giffnock Avenue, Centrecourt Estate, North Ryde, N.S.W. 2113, Australia

KENWOOD ELECTRONICS (HONG KONG) LTD.

Unit 3712-3724, Level 37, Tower one Metroplaza, 223 Hing Fong Road, Kwai Fong, N.T., Hong Kong

KENWOOD ELECTRONICS TECHNOLOGIES(S) PTE LTD.

Sales Marketing Division

1 Ang Mo Kio Street 63, Singapore 569110