

NOTE: REAR CONNECTORS TO BE SUPPLIED WITH CAPTIVE DUST CAPS.

Figure 2-1. Installation Drawing, RA 6790/GM HF Receiver

SECTION II INSTALLATION

2.1 UNPACKING AND INSPECTION

It is recommended that the shipping carton containing the RA7690/GM HF Receiver be examined for damage before the Receiver is unpacked. If damage to the carton is observable, try to have the carrier's agent present when the equipment is unpacked. If this is not possible, retain the shipping cartons and padding material for the carrier's inspection if damage to the equipment is evident after unpacking.

No special unloading equipment is required, except to handle the carton with normal care given to any shipping carton containing electronic equipment. Figures 2-1 and 2-2 show the critical dimensions and packaging details associated with the RA6790/GM HF Receiver. To unpack the Receiver, the following procedure should be observed.

1. Carefully open the top of the shipping carton and fold back the flaps.
2. Lift out the top foam cushion.
3. Carefully lift out the wrapped Receiver.
4. Remove the wrapping from the Receiver.
5. Carefully lift out the Receiver.
6. Place the Receiver on a convenient work bench.
7. Replace all packaging material back in the shipping carton. Save all material in the event that the Receiver must be reshipped.

See that the equipment is complete as listed on the packing slip. Contact your RACAL representative or RACAL Communications, Inc., Rockville, Maryland with details of any shortage.

The unit was thoroughly inspected and factory adjusted for optimum performance prior to shipment. It is, therefore, ready for use upon receipt. After uncrating and checking contents against the packing slip, visually inspect all exterior surfaces for dents and scratches. If external damage is visible, remove the dust covers and inspect the internal components for apparent damage. Then check the internal cables for loose connections, and plug-in items which may have been loosened from their receptacles.

2.2 PREPARATION FOR RESHIPMENT AND STORAGE

If the RA6790/GM must be prepared for reshipment, the packaging methods should follow the pattern established in the original shipment. If retained, the original materials can be used to a large extent or will at a minimum provide guidance for the repackaging effort. The Receiver must be disconnected and removed from its mounting rack before being prepared for reshipment. The following procedures describe the recommended sequence.

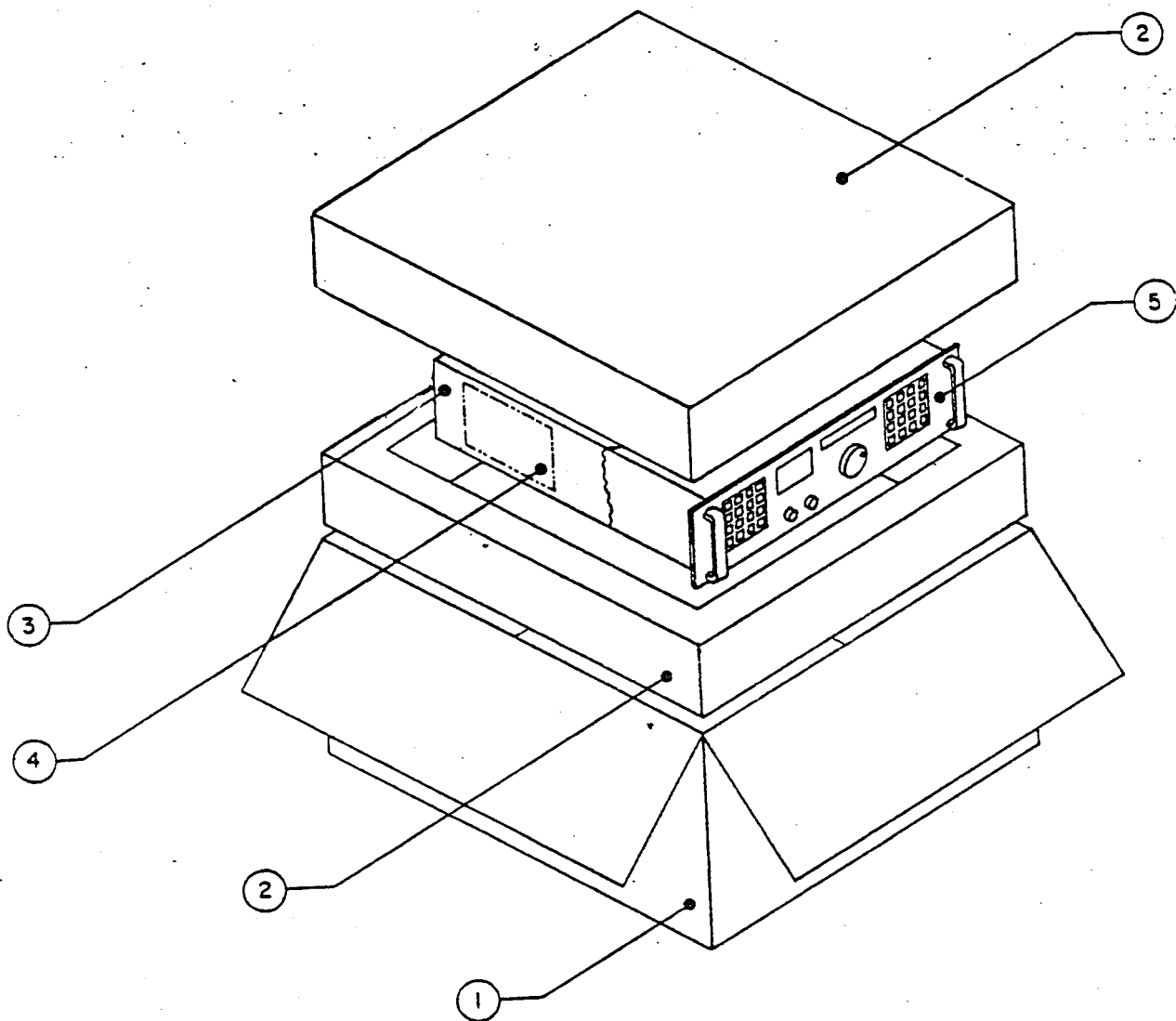

1. Exterior Container - 25-1/2" long by 23-1/2" wide by 10-1/2" deep.
2. Top and Bottom Cushions
3. Intimate Wrap.
4. Dessicant.
5. RA6790/GM Radio Receiver.

Figure 2-2. Packaging Details, RA6790/GM HF Receiver

1. Disconnect primary power cable W18 from its primary power source. Disconnect the other end of the cable from A10J1 on the rear panel of the Receiver.
2. Disconnect the antenna cable from J1-RF IN on the rear panel.
3. Disconnect the ground strap from the GROUND lug located on the rear panel.
4. Remove any other equipment or cables connected to connectors or jacks on the rear panel.
5. Remove headphones, if they are inserted, from the PHONES jack located on the front panel.
6. Remove the four mounting screws from the front panel securing the Receiver to the mounting rack.

WARNING

The Receiver weighs approximately 30 pounds. Be careful as the unit is removed from the rack. Have a firm grip on the handles as the weight leaves the rack so that it does not drop, causing injury to legs or feet.

7. Grasp the Receiver by handles on the front panel and slide the unit out of the rack. Place the unit on a bench.

The unit may be housed (stored), from inclement weather, in any structure that will sustain a temperature between -40° and $+70^{\circ}\text{C}$ and a relative humidity of 10 to 95 percent. The unit has an indefinite shelf life stored under the above conditions except for the nickel cadmium battery contained on circuit module board A6A2.

2.3 INSTALLATION

The Receiver is designed to be mounted in a standard 19-inch rack. The sides of the Receiver have been drilled and tapped to accept standard slides. The use of slides, however, is optional and is dependent on the individual site requirements. If slides are installed, it is recommended that cable retractors be used to simplify extending the Receiver out of the rack. If the unit is rack mounted without the slides, access to the rear panel must be provided for connection of cables and test equipment. The power dissipation of the Receiver is approximately 50 Watts with most of the power as heat. In most installations, special cooling will not be required. The top and bottom covers on the Receiver, as well as the heat sinks on the rear panel, must be unobstructed to permit proper air circulation. Critical dimensions of the RA6790/GM Receiver are shown in Figure 2-1.

2.3.1 Rear Panel Jacks, Switches and Connectors

Access to the rear panel should be allowed so that input and output connections can be conveniently made or changed if desired. All connections except for the headphones are made from the rear of the Receiver. A brief description of each rear panel switch and connector indicating function and input/output parameters is presented. Figure 2-3 presents the rear panel view of the Receiver showing the locations of the jacks, switches and connectors.

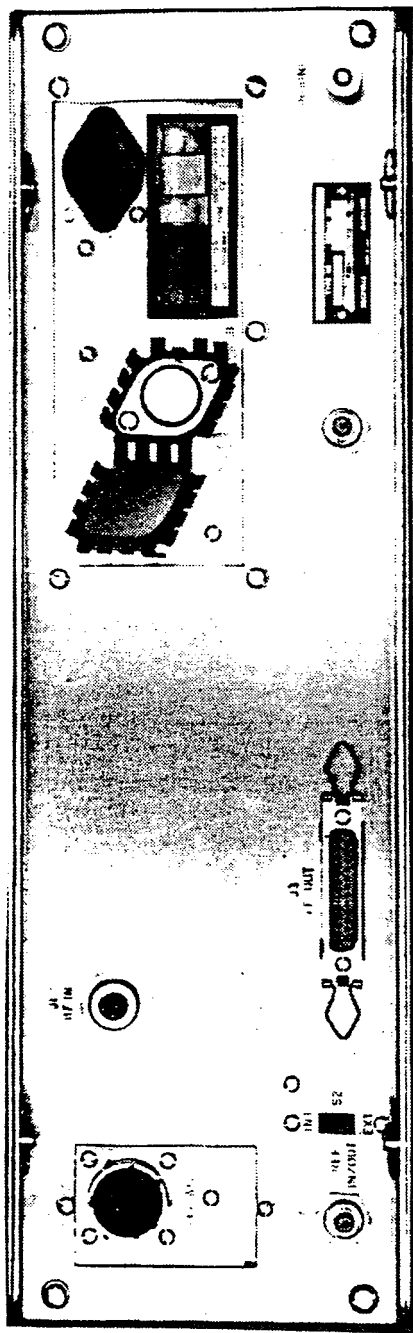

Figure 2-3. Rear Panel Jacks, Switches and Connectors

2.3.1.1 A10J1 Power Input Connector and Voltage Selector/Fuse Block Assembly

This multi-function assembly contains a three prong male power receptacle for attaching the power input cable, W18; hinged plastic FUSE PULL lever; line voltage select PC wafer and line fuse, F1. The power input cable is type BELDEN 17250. **CAUTION:** Verify that the PC wafer in A10 J1 on receiver rear panel matches available line voltage.

2.3.1.2 RF IN J1 Connector

The RF input from the antenna to the Receiver is made through the rear panel connector, J1. This connector is a standard N-type female connector and will mate with any standard N-type male connector. The input impedance at the connector is 50 ohms, unbalanced, with a VSWR of 2:1 over the operating frequency range of the Receiver.

2.3.1.3 IF OUT J2 Connector

The second IF output signal at 455 kHz is supplied by this female BNC-type connector which will mate with any standard male BNC-type connector. The output signal level at the connector is $-10 \text{ dBm} \pm 5 \text{ dB}$ for all CW input signals within the range of -107 dBm to $+13 \text{ dBm}$ with AGC selected. The impedance of the IF output is 50 ohms with a VSWR of 1.5:1.

2.3.1.4 AF OUT J3 Connector

This rear panel output connector is a 25-pin D-type connector providing audio, AGC and fault status outputs. The audio output frequency response at this connector is within 3 dB between frequencies of 100 Hz and 16 kHz. The following audio outputs are available:

1. Loudspeaker Output. An unbalanced output capable of $< 3\%$ distortion at 500 mW for 1W nominal into an 8 ohm load.
2. Monitor Line Output. A metered line output for receivers which do not contain the ISB option. Provides a 1 mW output at 600 ohms. The amplitude level is adjustable from the front panel.
3. Line 1. Line output for non-operating ISB mode when the ISB is installed. Output is 1 mW at 600 ohms balanced.
4. Line 2. Line output for the LSB component in the ISB operating mode. Output is 1 mW at 600 ohms balanced.
5. PHONES. This unbalanced output is capable of 10 mW at 600 ohms and is available through a front panel jack.

If the Receiver is not equipped for ISB operation, the Line 1 and Line 2 outputs are not used. The Monitor Line output, Loudspeaker output, and the front panel PHONES jack provide the audio output for the Receiver for all operating modes. When the Receiver is equipped for and is operating in the ISB mode, the Line 1 output will contain the USB audio and the Line 2 output will contain the LSB audio. The Monitor Line and Loudspeaker outputs, along with the front panel PHONES jack will provide either USB or LSB audio as controlled by the front panel ISB U/L pushbutton. With the Receiver equipped for ISB operation but not operating in the ISB mode, the

Line 1, Monitor Line, and Loudspeaker outputs, along with the front panel PHONES jack, provide the audio.

Other outputs available at this connector are the AGC and Fault indicator outputs.

The Main IF and ISB-LSB AGC Monitor/Input terminals may be used to control the AGC for diversity combining or to monitor the AGC voltage. For diversity combining, the Main IF AGC signal (on pin 21 of J3) of one receiver may be connected to pin 21 of the second receiver. If the receiver is equipped for ISB operation, pin 22 of one receiver may be connected to pin 22 of the second receiver. The AGC circuits in both receivers will automatically respond to the proper signal. The Fault Indicator output will be high (logic 1, +2 Volts to +5 Volts) when a fault is not present in the Receiver. This output will go low (logic 0, 0 Volts to +0.8 Volts) when one of the synthesizer circuits has failed or if a parity error is detected during remote control (optional).

2.3.1.5 REF IN/OUT J7 Connector

This rear panel connector is used in conjunction with Slide Switch, S2. Depending on switch position, the Receiver will either accept an external 1 MHz reference input or supply a 1 MHz reference output through J7. The circuitry has an input impedance of 50 ohms and will operate with peak-to-peak signal levels of 1.0V, $\pm 0.5V$. The J7 connector will mate with any standard male BNC-type connector. Additionally, provision for changing the reference frequency to either 5 MHz or 10 MHz is available by making link changes (Refer to Paragraphs 2.3.4 and 2.3.4.5, Receiver System Connections) on the A8 assembly.

2.3.1.6 A6A1W1J1 Remote Control Interface Connector

This optional connector is a round, 26-pin MIL-Type MC3723-02R-1626N and permits the Receiver to be operated from a remote control device. A mating connector is supplied with the A6A1 Remote Option. Depending on which interface is required, pin connections, jumper options and baud rate selection must be appropriately set. (Refer to Paragraphs 2.3.4 and 2.3.4.6, Receiver System Connections.)

2.3.1.7 INT EXT S2 Slide Switch

Setting this switch to the INT position selects the internal time base for the Receiver and provides the internal 1 MHz reference output at connector J7. Setting the switch to the EXT position deactivates the internal reference so that an external signal may be applied to J7. The Receiver is normally shipped from the factory with the 1 MHz reference present, however, provision for changing to 5 MHz or 10 MHz is available by changing links on the A8 assembly. (Refer to Paragraph 2.3.4 and 2.3.4.5.)

2.3.1.8 GROUND Lug

A GROUND Lug is located at the lower right corner of the receiver rear panel. Ensure that adequate grounding techniques are employed when operating, installing options and performing maintenance functions on the RA6790/GM Receiver.

2.3.1.9 PHONES Jack

This output is intended to drive a 600 ohm headphone set and provides an audio output for the Receiver for all operating modes.

2.3.2 Installation Options

The external options associated with the Receiver include plug-in or solder-in IF bandwidth filters, independent sideband (ISB) operation, and operating the Receiver through a remote control device. One or more of the plug-in or solder-in filters must be installed before the Receiver can operate. The ISB and remote control capabilities, however, are optional. Because of the different possible filter combinations and the options, it is recommended that a receiver configuration chart or log book be maintained for each Receiver. The configuration chart or log book would list the IF bandwidth filters currently installed in the Receiver, the operating options, the type of remote control interface, as examples.

In addition, an internal option of operating the RA6790/GM Receiver with a 1, 5 or 10 MHz reference is available by changing links on the A8 assembly.

2.3.3 RA6790/GM Receiver Options Installation Procedures

The installation procedures for the Receiver may be logically divided into three steps: (1) Installation of the primary operating options to include the plug-in (solder-in) filters, independent sideband and remote control interface; (2) making the required system connections; and (3) installation of the Receiver in an operational position. Paragraphs 2.3.3.1 through 2.3.4.6 detail the installation steps necessary for preparing the RA6790/GM HF Receiver for operation. Figures 2-4 through 2-9 are photographs of the details associated with installing the receiver operating options.

2.3.3.1 Optional IF Bandwidth Filters

The standard RA6790/GM Receiver is supplied with soldered-in mechanical filters and input and output shunt capacitors, (Table 6.1, Section VI). If conversion to plug-in filters is desired, actual removal of these items should be performed at the RACAL Communications, Inc. factory location in Rockville, Md.

The Receiver can be supplied with from 1 to 7 plug-in filters. Table 2-1 lists all the optional filters available. Mounted on the A4 board, the filters are accessible from the top of the Receiver. To gain access to the A4 board, loosen the six quarter-turn fasteners holding the top cover to the Receiver and carefully remove the top cover. A retaining cover is used with the crystal filters. Remove the three screws holding this cover to the chassis and remove the cover. Figure 2-4 illustrates the seven filter slots on the A4 board.

If a receiver configuration chart has been prepared for this particular Receiver, refer to the chart and determine if the Receiver is to be operated with the ISB option. If the receiver configuration chart was not prepared, determine if the ISB option is to be included by checking the shipping data or the station manual, as appropriate. When operating with the ISB option, both upper and lower sideband filters must be installed in the Receiver, and the lower sideband filter must be installed in the FL1 position. If the ISB option is not used, either a lower sideband filter or symmetrical sideband filter may be installed in the FL1 position. When a lower sideband filter is installed, the companion upper sideband filter must be installed in one of the remaining filter positions. If a symmetrical sideband filter is used, the Receiver will use the filter installed in the FL1 position for both sidebands by making the appropriate frequency offsets to the first and last local oscillators. The remaining filters may be installed in any sequence in filter positions FL2 through FL7. However, in order to simplify system operation and troubleshooting, it is recommended that a format be established and used for all Receivers at a particular site.

Once the filter complement and arrangement has been determined, the following procedure should be used to insert the plug-in filters into the Receiver. Refer to Figures 2-4 and 2-5.

1. Working from the front of the Receiver, position the filter to be used for LSB operation over filter position FL1 (the filter position closest to the rear of the Receiver). Make certain that the large pins are aligned with the large sockets and the smaller pins are aligned with the smaller sockets.

TABLE 2-1. RA6790/GM OPTIONAL BANDPASS FILTER LIST

*Mechanical Filters. All Others are Crystal Filters.

Bandwidth	Description	Shape Factor 3 dB: 60 dB	Differential Delay μ S	Racal Number
* 0.3 kHz	Symmetrical BPF	1:6.7	—	07883-1
* 1.0 kHz	Symmetrical BPF	1:4.5	—	07883-2
* 3.2 kHz	Symmetrical BPF	1:2.7	—	07883-3
* 4.0 kHz	Symmetrical BPF	1:2.5	—	3600001
* 5.0 kHz	Symmetrical BPF	1:2.5	—	3600002
* 6.0 kHz	Symmetrical BPF	1:2.3	—	07883-4
* 450 Hz to 3000 Hz	ISB/USB BPF	1:1.92	—	07883-5
* 450 Hz to 3000 Hz	ISB/LSB BPF	1:1.92	—	07883-6
* 350 Hz to 2700 Hz	USB BPF	1:1.66	—	08669
* 300 Hz to 2200 Hz	USB BPF	1:1.97	—	08771
1.0 kHz	Symmetrical BPF	1:6	25	3600003
3.0 kHz	Symmetrical BPF	1:6	13	3600004
6.0 kHz	Symmetrical BPF	1:6	10	3600005
1.0 kHz	Symmetrical BPF	1:2.5	1080	3600006
3.0 kHz	Symmetrical BPF	1:2.5	360	3600007
6.0 kHz	Symmetrical BPF	1:2.5	180	3600008
0.125 kHz	Symmetrical BPF	1:5.33	—	08699
0.4 kHz	Symmetrical BPF	1:6.2	—	08406
1.2 kHz	Symmetrical BPF	1:6	—	08407
6.8 kHz	Symmetrical BPF	1:3.3	—	08408
350 Hz to 3050 Hz	ISB/LSB BPF	1:1.6	800	08409
350 Hz to 3050 Hz	ISB/USB BPF	1:1.6	800	08410
0.4 kHz	Symmetrical BPF	1:2.5	2000	08411
1.2 kHz	Symmetrical BPF	1:2	1000	08412
3.24 kHz	Symmetrical BPF	1:1.33	1000	08413
6.8 kHz	Symmetrical BPF	1:2	1000	08414
16.0 kHz	Symmetrical BPF	1:2	40	08415
0.5 kHz	Symmetrical BPF	1:6	80	08416
1.0 kHz	Symmetrical BPF	1:6	40	08417
2.0 kHz	Symmetrical BPF	1:6	20	08418
3.0 kHz	Symmetrical BPF	1:6	20	08419
6.0 kHz	Symmetrical BPF	1:6	20	08420
0.075 kHz	Symmetrical BPF	1:6.67	—	08589

- Carefully push down on the filter to insert the pins into the sockets. Relatively light pressure is required to insert the pins into the sockets. If the filter does not easily slide into place, recheck the pin/socket alignments.
- Insert the appropriate filters into filter positions FL2 through FL7 (as required), using the procedures described in steps 1 and 2.
- After all filters have been inserted, visually inspect the filters to insure that they are properly seated. The bottom of the filters should be flat against the surface of the A4 board.
- Replace the RF shield over the filters and secure the shield in place by tightening the three screws.

NOTE

If the Receiver is to be equipped for operation from a remote control device or in the ISB mode, continue with the procedures described in Paragraphs

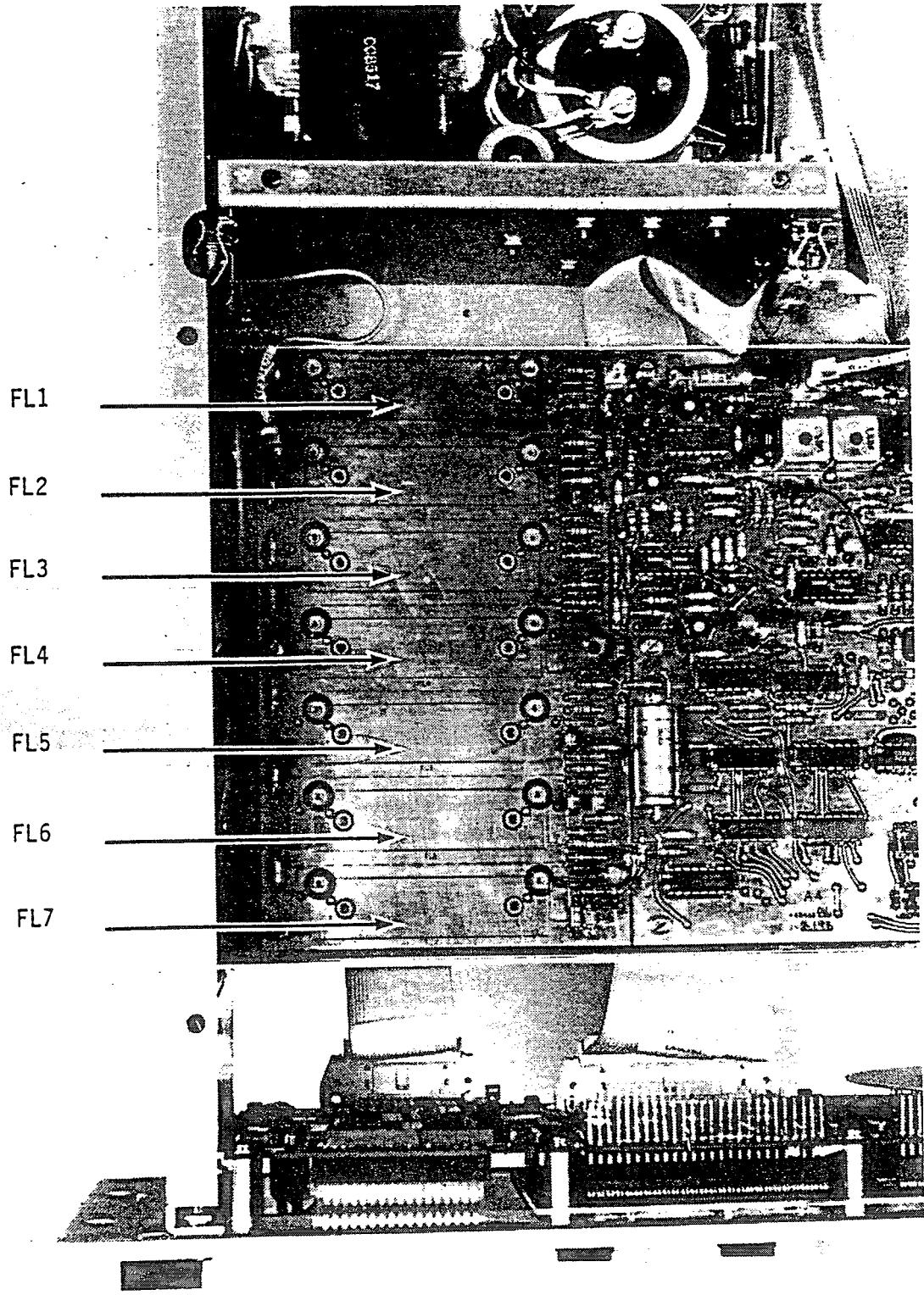

Figure 2-4 Location of IF Bandwidth Filter Slots

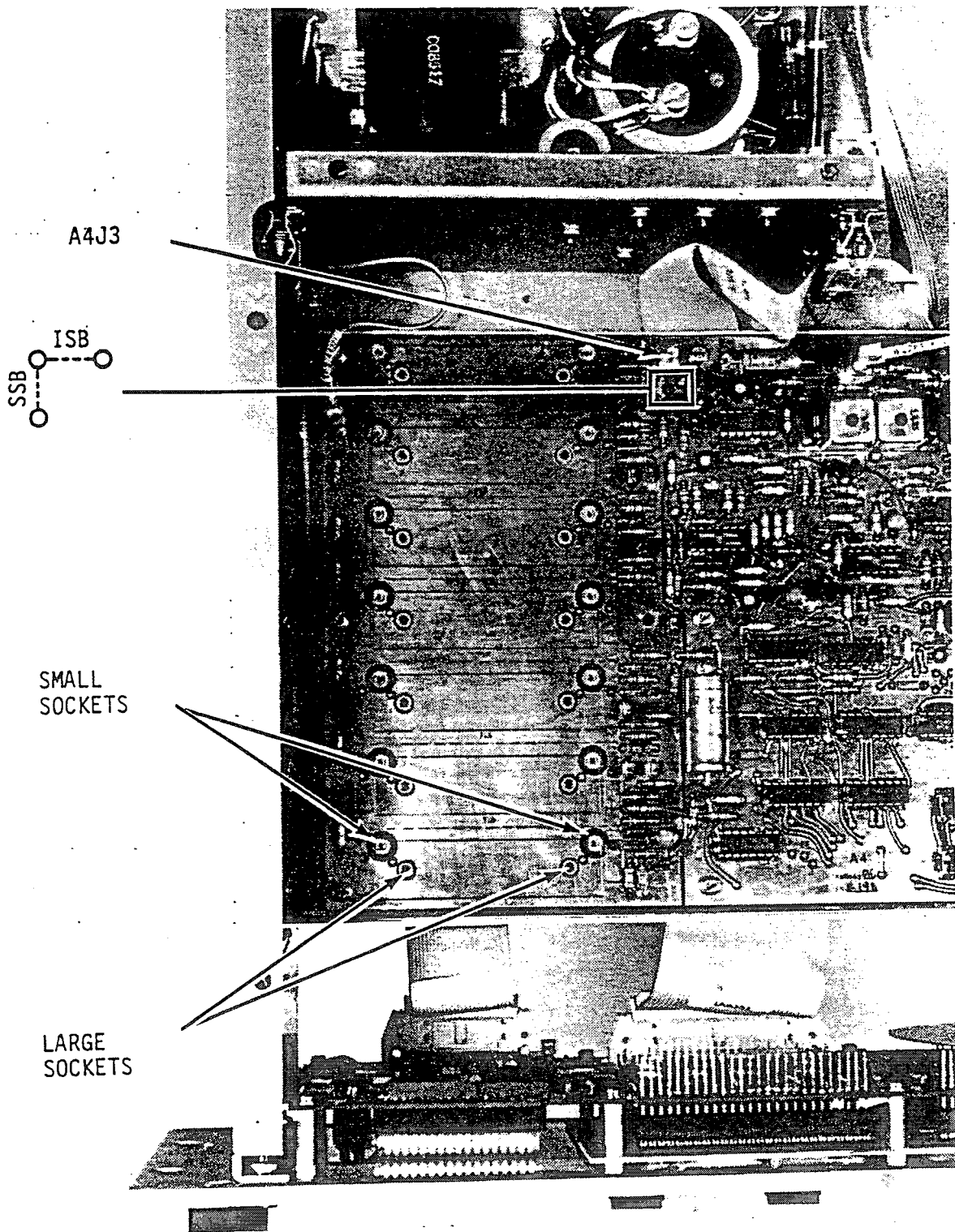

Figure 2-5. Location of Filters and Jumpers, A4 Circuit Card Assembly

2.3.3.2 and 2.3.3.3. If the Receiver is not to be equipped with these two options, replace the top cover on the receiver chassis, and proceed to Paragraph 2.3.3.4, Line Level Adjustments.

2.3.3.2 Remote Control Serial Asynchronous Interface

When the Receiver is operated with the remote control option, the A6A1 circuit card assembly must be installed in the Receiver. In order to install this card, the A6A2 circuit card assembly must be removed from the Receiver and mated with the A6A1 card. The two cards are then inserted back into the Receiver as an assembly. The following procedure details the steps necessary to install the cards.

1. Working from the front of the Receiver, disconnect the A9W1 cable assembly from the A6A2 card. This cable assembly connects to A6A2J1 located on the front of the A6A2 card. Figure 2-6 illustrates the A6A2 and A6A1 circuit card assemblies installed in the Receiver and the location of A9W1.
2. Remove the three screws located along the top edge of the A6A2 card and carefully remove the card from the Receiver.

CAUTION

Do not place the A6 circuit card assembly on any conductive material. Failure to comply may result in shorting the battery contained on this card.

3. Check the rear panel of the Receiver. A blank plate may be covering up the hole (located on left hand side of the rear panel) for the remote control interface socket. If the blank plate is present, remove the two screws holding the plate and remove the plate.
4. A hard-wired link, LK1, must be removed from the A6A2 card when the remote control option is used. The link is physically located between U1 and U2 (the two 40-pin LSI chips located near the J2 connector). Use a pair of cutters (or a low wattage soldering iron) to remove the link. Refer to Figure 2-7 for the location of the link.
5. There are a total of 6 different mechanical links located on the A6A1 circuit card assembly that must be installed according to the interface to be used. Table 2-2 lists the mechanical links required for each interface. Use a low wattage soldering iron to install or remove the links as required. Refer to Figure 2-8 for the location of the links.

TABLE 2-2. LINK DESIGNATIONS, REMOTE CONTROL INTERFACE

Link Designation	188C/232C/423 Interface	RS422 Interface
LK1	Install	Install
LK2	Remove	Remove
LK3	Install	Remove
LK4	Install	Remove
LK5	Install	Remove
LK6	Remove	Install

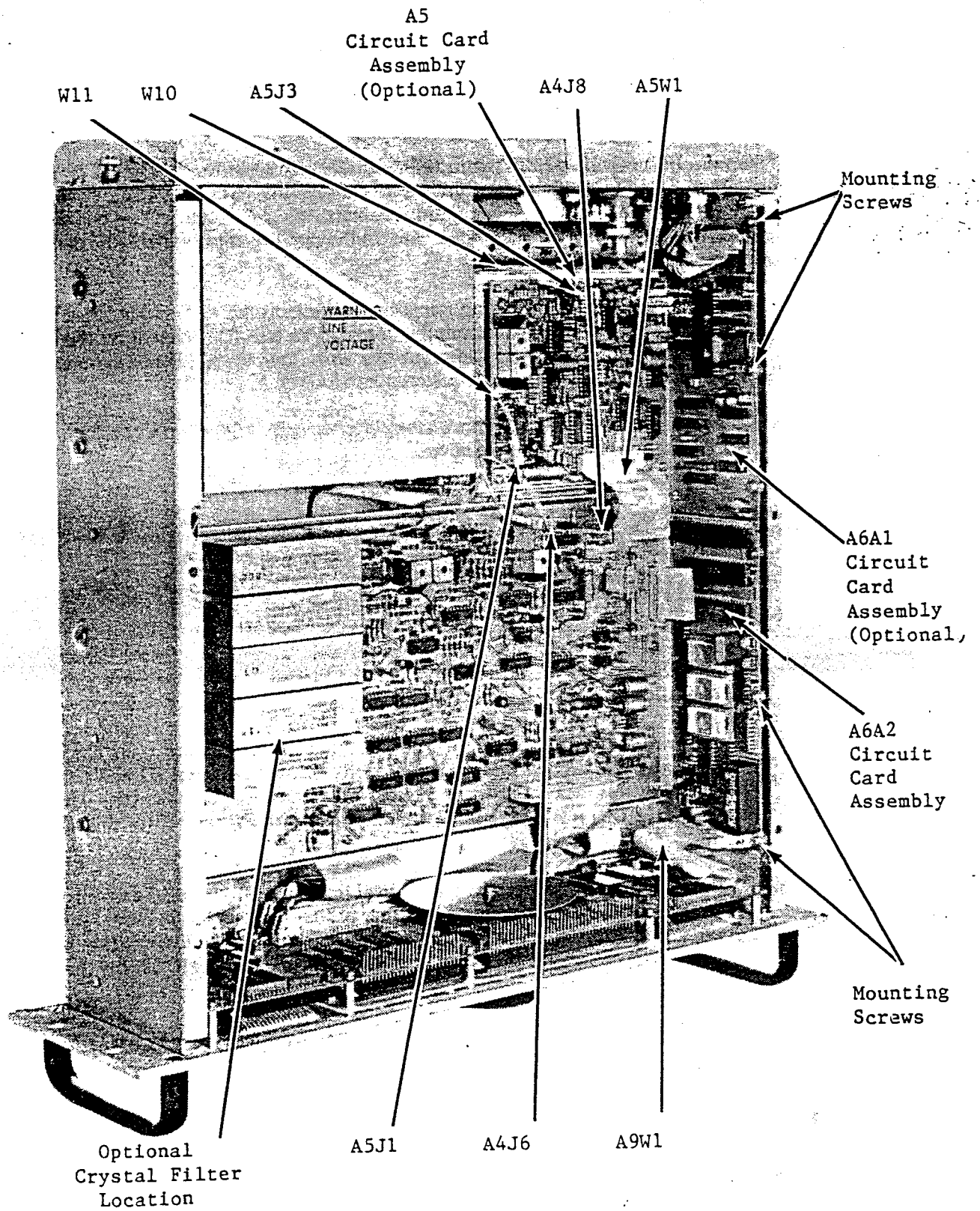
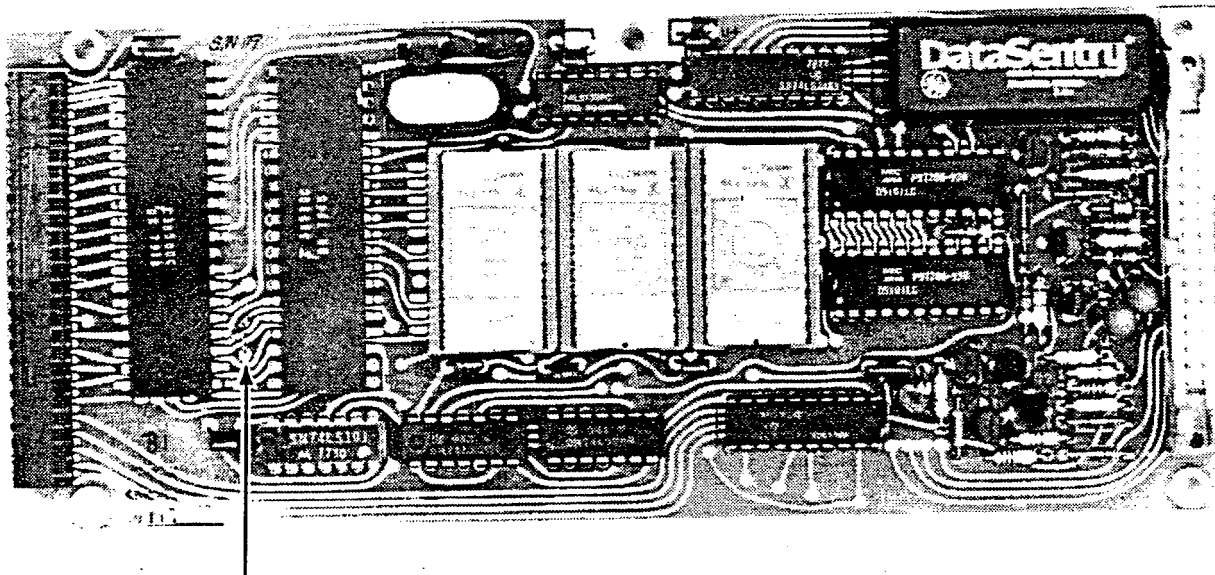

Figure 2-6. Receiver Options, Installation Detail



Link 1

Figure 2-7. A6A2 Circuit Card Assembly Jumpers

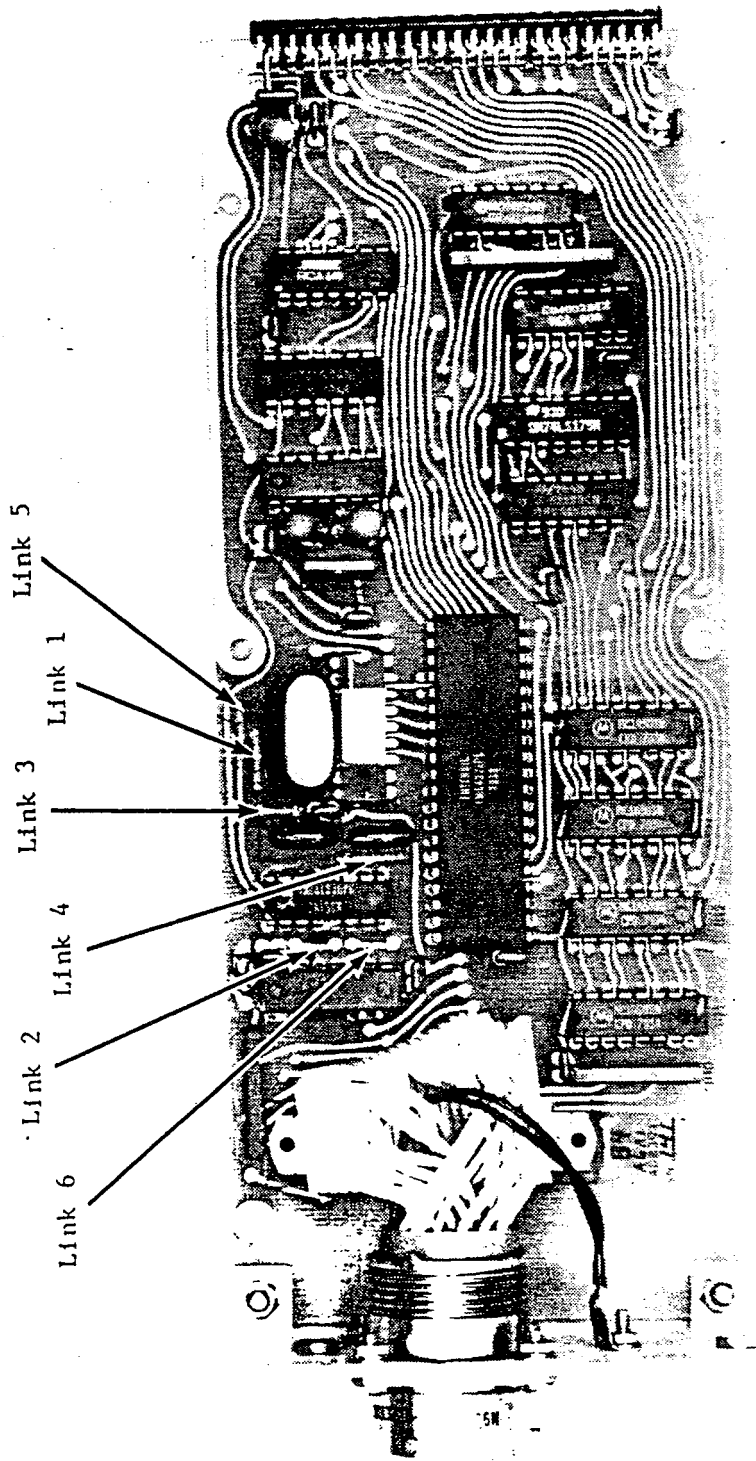

Figure 2-8. A6A1 Circuit Card Assembly Jumpers

6. Align the 50-pin male connector on the A6A1 circuit card assembly with the 50-pin female connector on the A6A2 circuit card assembly as shown in Figure 2-9. Mate the two connectors.
7. Carefully place the two cards into the receiver chassis. Make certain the remote control interface connector (A6A1W1J1) clears the hole in the rear panel.
8. Position the two cards on the card guide attached to the receiver chassis. Secure the cards with 6 screws (3 screws on each card) to the side of the chassis. Secure the interface connector to the rear panel with two screws. Figure 2-6 illustrates the two cards installed in the Receivers.
9. Reconnect the A9W1 cable assembly (removed in step 1) to connector A6A2J1.

NOTE

If the Receiver is to be equipped for operation in the ISB mode, continue with the procedure described in Paragraph 2.3.3.3. If the ISB option is not to be installed, replace the top cover on the receiver chassis and proceed to Paragraph 2.3.3.4, Line Level Adjustments.

2.3.3.3 Independent Sideband (ISB)

If the Receiver is to be operated in the ISB mode, the A5 circuit card assembly must be installed in the Receiver. The A5 card is located towards the rear of the Receiver, between the A1 assembly and the A4 circuit card assembly as shown in Figure 2-6. The following procedure details the steps necessary to install the A5 circuit card assembly. Refer to Figures 2-5 and 2-6 for the location of cables and connectors.

1. Place the metal baseplate shield (curved edge upwards) on the four standoffs and secure with four screws through the standoffs.
2. Position the A5 circuit card assembly so that the ribbon cable is near the J8 connector on the A4 circuit card assembly. Secure the A5 circuit card assembly to the metal baseplate with 4 screws.
3. Plug in the ribbon cable (A5W1) from the A5 card into J8 on the A4 board. Connect coaxial cable W10 between A4J6 and A5J3. Connect coaxial cable W11 between A4J3 and A5J1.
4. The mechanical jumper on the A4 circuit card assembly must be properly positioned for ISB/SSB operation. The jumper, designated LK1, is physically located to the right of filter position FL1 when looking from the front of the Receiver. (Refer to Figure 2-5.) With the A5 circuit assembly installed, the jumper must be connected across the two terminals designated ISB.

NOTE

Upon completing all required installation options procedures, it is recommended that the Line Level Adjustment procedure be performed as outlined in Paragraph 2.3.3.4. Upon completing this adjustment procedure, the RA6790/GM Receiver Options Installation Check as described in Section III, Paragraph 3.3.1 should be performed. After completing this operational check, it is suggested that the System Connection be made in accordance with the procedure listed in Paragraphs 2.3.4 through 2.3.4.6.

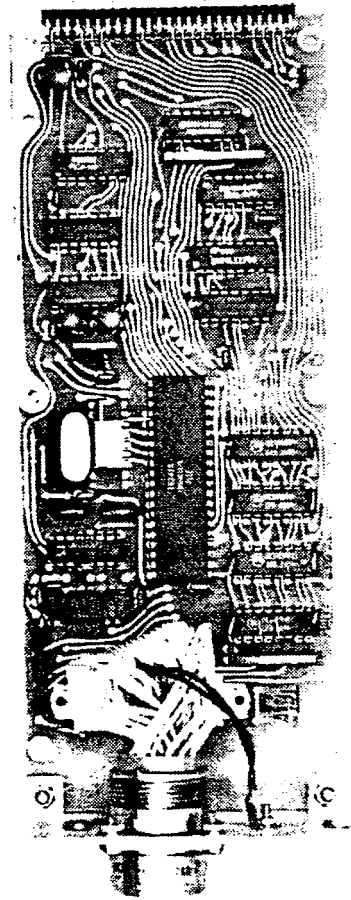
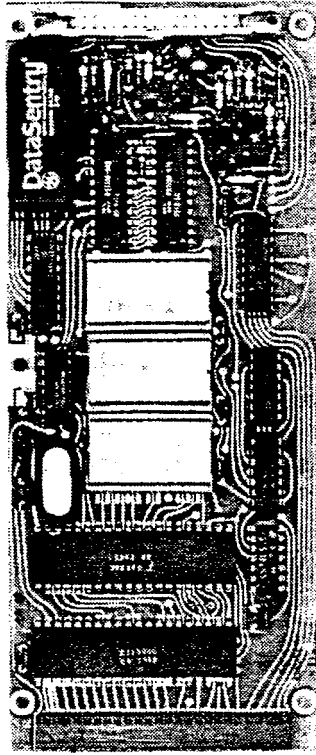

Figure 2-9. Mating A6A1 and A6A2 Circuit Card Assemblies

2.3.3.4 Line Level Adjustments

The following procedures are detailed for adjustment of the audio line level, required upon installation of the Receiver.

1. For MAIN LINE LEVEL Adjustments:

a. Set the following controls as indicated:

POWER switch	ON
AGC	SHORT
METER switch	AF
MODE	AM (depress AM pushbutton switch on lefthand keypad until the word AM is displayed under the word MODE in the Mode LCD).
BW	Approximately 6 kHz

- b. Connect the AM output (with modulation set for 30%) from an RF signal generator (HP8640, or equivalent) set to a frequency of 3.50000 MHz and an output of -97 dBm, to the RF IN connector J1 on the rear panel.
- c. Set the receiver frequency to 3.50000 MHz.
- d. Using a screwdriver, adjust the MAIN LINE LEVEL potentiometer on the receiver front panel for 1 mW audio output level, as indicated by the 0 dB line on the AF meter scale in the Mode LCD.
- e. Turn POWER switch to off and disconnect the generator.

2. For I-LSB LINE LEVEL Adjustment:

a. Set the following controls as indicated:

POWER switch	ON
AGC	SHORT
METER switch	AF
MODE	I-LSB (depress ISB U/L switch on lefthand keypad once or twice until the I-LSB word is displayed under the word MODE in the Mode LCD).
BW	Approximately 6 khz

- b. Connect the AM output (with modulation set for 30%) from an RF signal generator (HP8640, or equivalent) set to a frequency of 3.50000 MHz and an output of -97 dBm, to the RF IN connector J1 on the rear panel.
- c. Set the receiver frequency to 3.50000 MHz.
- d. Using a screwdriver, adjust the I-LSB LINE LEVEL potentiometer on the receiver front panel for a 1 mW audio output level, as indicated by the 0 dB line on the AF meter scale in the Mode LCD.

NOTE

The USB line level was adjusted when the MAIN LINE LEVEL was set since the USB AF uses the main AF channel when the Receiver is in the USB mode.

- e. Turn POWER switch to off and disconnect the generator.

2.3.4 RA6790/GM Receiver System Connections

System connections for the Receiver are based on the individual site requirements and the options associated with a Receiver. The site requirements will determine the most effective method of installation. In some installations, it may be easier to pre-wire an entire equipment rack and then install the Receiver. In others, it may be easier to install the Receiver and then add the wiring. The following paragraphs detail the procedures associated with installing the Receiver. Figure 2-10 illustrates the connectors located on the rear panel of the Receiver.

2.3.4.1 Power Input Connections

A three-conductor power cord is supplied with the Receiver for connection to the power input plug. The connector has the following pin assignments, as viewed from the rear panel:

Left Pin:	LINE
Center Pin:	GROUND
Right Pin:	NEUTRAL

With the power cable unplugged from the Receiver, the clear plastic window can be slid over the three male power receptacle prongs. This exposes the line fuse and a hinged, plastic FUSE PULL lever. If the voltage shown does not match the available line voltage, remove the pc wafer and reinstall it so that the line voltage closest to the available line voltage is visible with the pc wafer in position. Install the fuse suitable for the line voltage: 1 amp slow-blow for 100V ac and 120V ac, or ½ amp for 220V ac and 240V ac. (An extra fuse may be installed in the alternate fuse holder, XF2 which is located internally on the A10 Power Supply Assembly.) Slide the clear plastic window back over the fuse and pc wafer portion of the fuse holder assembly and insert the power cable, W18, in the receptacle. Additionally, the Receiver should be grounded by attaching a suitable ground wire to the rear panel GROUND lug before the power cable, W18, is attached.

The Receiver is normally shipped from the factory configured for operation with a 120 volt, $\pm 10\%$, 48 to 420 Hz ac source. For receiver operation with a 240 volt source, the Receiver must be re-configured as follows:

1. Disconnect the Receiver from all system equipment and remove the power cord.
2. On the power input connector assembly A10J1: Slide the transparent protective cover to the left to expose the fuse; remove the fuse; remove the printed circuit wafer, and then replace the wafer with the required nominal operating voltage visible; replace the fuse and restore the protective cover to its original position and connect or re-connect the receiver system connections.
3. The unit is now ready for operation from the selected line voltage, $\pm 10\%$.

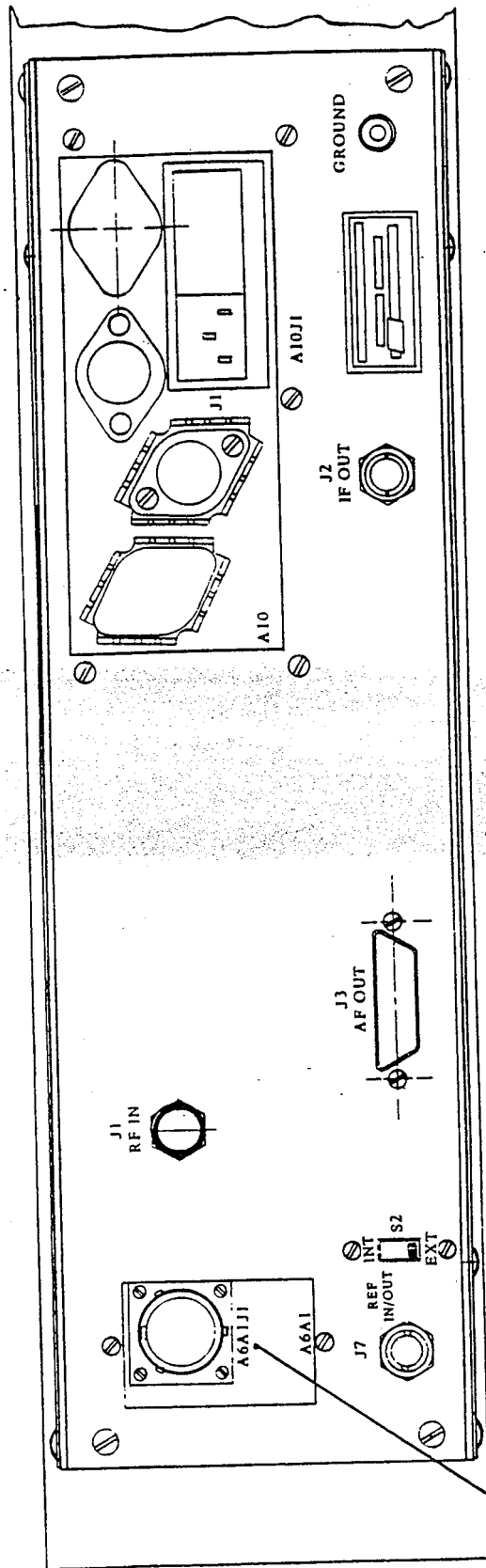

Figure 2-10. RA6790/GM Rear Panel System Connections

OPTIONAL REMOTE CONTROL INTERFACE.

CAUTION

The supply voltage should remain within 10% of the selected terminal voltage. A lower voltage can cause the internal regulation circuits to trip and a higher voltage can cause excessive internal temperatures.

2.3.4.2 RF Input Connector (J1)

The Receiver is shipped with a plastic dust cover over connector J1 which must be removed before the antenna connection can be made. Ensure that a suitable antenna is selected. The input impedance at the connector is 50 ohms, unbalanced with a VSWR of 2.1.

2.3.4.3 IF Output Connector (J2)

The IF Output Connector J2 located on the rear panel is shipped with a plastic dust cover which must be removed before connection. During operation, a 455 kHz frequency is supplied at this connector for connection to external equipment. Nominal level is -10 dBm into 50 Ohms.

2.3.4.4 AF Output Connector (J3)

A mating connector (Cannon type DB-25P) with a connector shell is supplied with the Receiver. Use the following procedure, and pin number/signal designation information in Table 2-3 to wire the connector.

1. Slide the connector shell over the cable to be used.
2. Solder the cable wires to the connector as required (refer to Table 2-3). The connector pin numbers are indicated on the front of the connector.
3. Slide the connector back into the connector shell. Place one of the spring clips on top of the connector with the curved edge pointing upwards. Secure the spring clip and the connector to the connector shell with the self-tapping screw. Repeat this procedure for the other side of the connector.
4. Connect the wired cable to the rear panel connector J3 and secure with two connector springs.

2.3.4.5 Reference Input/Output Connector (J7)

This BNC-type connector is used in conjunction with the INT/EXT S2 slide switch to accept an external reference source or provide an output of the internally generated reference signal. The reference frequency may be generated by a temperature controlled crystal oscillator (TCXO) located on circuit card A8, or by a frequency source external to the receiver. The receiver is normally shipped from the factory with a preset 1 MHz reference. Provision is made, however, for compatibility with a 5 or 10 MHz source through internal linkage on the A8, 2nd LO/BFO Synthesizer Board.

After determining the frequency source compatibility requirements, refer to Table 2-4 and make the following link changes on the A8 circuit board if required.

TABLE 2-3. AF OUT J3 PIN CONNECTIONS

Pin Number	Signal Designation	
1	Output	Line 1 Output (Used only with ISB Option). Provides USB output during ISB operation; AM/FM/CW/SSB output during non-ISB operation.
2	Center Tap	
14	Output	
3	Output	Line 2 Output (Used only with ISB Option). Provides LSB output during ISB operation.
16	Center Tap	
15	Output	
4	Output	Monitor Line Output. Provides AM/FM/CW/SSB output during non-ISB operation; provides switch controlled selection of USB or LSB during ISB operation.
5	Center Tap	
17	Output	
18	Output	Loudspeaker Output. Same as Monitor Line Output.
6	Signal Ground	
7, 8, 9	Ground	
10,11,12,13 19,20,24,25	Not Connected	
21	Main IF Diversity AGC Monitor/Input	
22	ISB Lower Sideband Diversity AGC Monitor/Input	
23	Fault Indicator (Low indicates Fault)	

1. For 1 MHz operation, LK1 and LK2 are linked (E1 to E2, and E3 to E4 respectively).
2. For 5 MHz operation, LK2 ONLY is linked (E3 to E4).
3. For 10 MHz operation, LK1 ONLY is linked (E1 to E2).

TABLE 2-4. EXTERNAL/INTERNAL LINK OPTIONS

FREQUENCY SOURCE SELECTION	
1 MHz	Connect LK1 and LK2
5 MHz	Connect LK2
10 MHz	Connect LK1

Upon completing the required link changes, ensure that switch, S2 INT/EXT located on the rear panel is set in the appropriate position.

2.3.4.6 Remote Control Serial Asynchronous Interface Connections (A6A1W1J1)

The Receiver is supplied with a mating connector for the remote control interface connector. Figure 2-11 illustrates the pin designations and assigned functions. The pins designated A through J vary in function according to the interface being used, as is shown in Table 2-5. The remaining pins K through c are the same for all the listed interfaces. Table 2-6 lists the baud rate selection bit associated with pins W through Z for different data rates (baud) selection. Table 2-7 lists the required link configurations on the A6A1 circuit card assembly for the different interfaces.

To make the required connections:

1. Slide the mating connector shell over the cable to be used for the remote control.
2. Solder the wires to the appropriate connector pins in accordance with Figure 2-11 and Tables 2-5 and 2-6 for the interface to be used. The connector pins are designated on the front of the connector.
3. After carefully checking all wiring, slide the connector into the connector shell and secure the cable clamp. Attach and secure the connector to A6A1W1J1.
4. Visually inspect the A6A1 circuit card assembly to insure that all jumpers are installed in accordance with Table 2-7.

NOTE

The MIL-STD-188C and RS-232-C interfaces are electrically compatible. The distinction between the two is the polarity definition for "MARK" or "LOGIC 1." RS-232-C defines "MARK" as a negative potential while MIL-STD-188C defines "MARK" as positive. Therefore, pin functions (Figure 2-11, Table 2-5) marked DATA IN A/DATA OUT A are "MARK" negative and DATA IN B/DATA OUT B are "MARK" positive.

TABLE 2-5. DATA CONNECTION INTERFACE COMPATIBILITY

J1 Pins	MS188C	RS232C - RS423	RS422
A	System Gnd.	System Gnd.	System Gnd.
B	Not Used	Data Out A	Data Out A
C	Data Out Gnd.	Data Out Gnd.	Not Used
D	Data Out	Not Used	Data Out B
E	Jumper to 'F'	Not Used	Not Used
F	Jumper to 'E'	Data In A'	Data In A'
G	Data In Gnd.	Data In Gnd.	Not Used
H	Data In	Jumper to 'J'	Data In B'
J	Not Used	Jumper To 'H'	Not Used

TABLE 2-6. INTERFACE CONNECTOR BAUD RATE SELECTION

Data Rate Selection Bit				Data Rate
W	X	Y	Z	(Baud)
0	0	0	0	50
0	0	0	1	75
0	0	1	0	110
0	0	1	1	134.5
0	1	0	0	150
0	1	0	1	300
0	1	1	0	600
0	1	1	1	1,200
1	0	0	0	1,800
1	0	0	1	2,000
1	0	1	0	2,400
1	0	1	1	3,600
1	1	0	0	4,800
1	1	0	1	7,200
1	1	1	0	9,600
1	1	1	1	19,200

TABLE 2-7. A6A1 LINK CONFIGURATIONS

Link No.	188C/232C/423	422
LK1	Install	Install
LK2	Remove	Remove
LK3	Install	Remove
LK4	Install	Remove
LK5	Install	Remove
LK6	Remove	Install

TABLE 2-8. PARITY SELECT

No Parity	High	Open
Parity	Low	Ground
Even	High	Open
Odd	Low	Ground

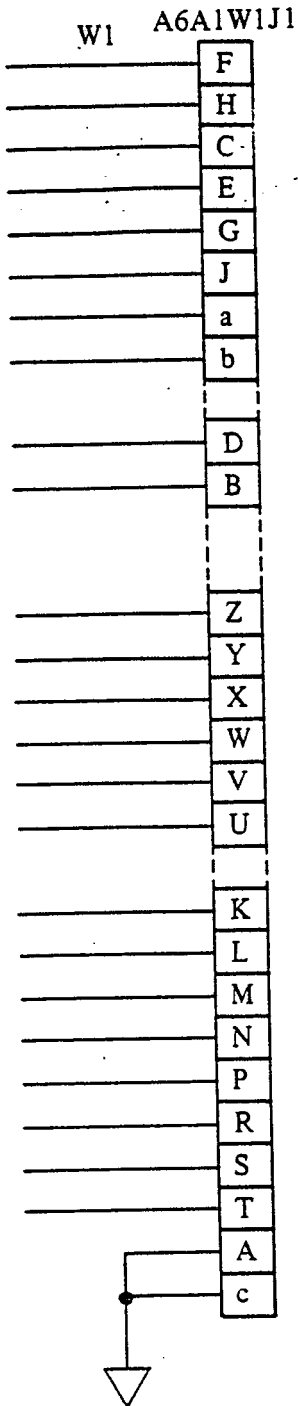

J1 Pins	Function
A	SYSTEM GND
B	DATA OUT A
C	DATA OUT GND
D	DATA OUT B
E	GND
F	DATA IN A'
G	DATA IN GND
H	DATA IN B'
J	GND
K	RECEIVER NUMBER D1-1
L	RECEIVER NUMBER D1-2
M	RECEIVER NUMBER D1-4
N	RECEIVER NUMBER D1-8
P	RECEIVER NUMBER D2-1
R	RECEIVER NUMBER D2-2
S	RECEIVER NUMBER D2-4
T	RECEIVER NUMBER D2-8
U	/PARITY SELECT
V	EVEN/ODD PARITY
W	BAUD RATE B4
X	BAUD RATE B3
Y	BAUD RATE B2
Z	BAUD RATE B1
a	GND
b	GND
c	SYSTEM GND

Figure 2-11. Remote Control Connector Pin Designations and Functions