

OPERATOR'S MANUAL

OMNI VI

MODEL 563

HF TRANSCEIVER

TABLE OF CONTENTS

<u>PARAGRAPH</u>	<u>PAGE</u>
TABLE OF CONTENTS	i
LIST OF ILLUSTRATIONS	v
LIST OF TABLES	vi
INTRODUCTION	vii
SPECIFICATIONS	viii

1. INSTALLATION

1-1	POWER SUPPLY	1-1
1-2	ANTENNAS	1-1
1-3	MICROPHONE	1-2
1-4	CW KEY, INTERNAL/EXTERNAL	1-2
1-5	STATION GROUND	1-2
1-6	CONNECTING OTHER ACCESSORY EQUIPMENT	1-3
1-7	TEN-TEC ACCESSORIES FOR OMNI VI	1-3
1-8	INSTALLING INTERNAL OPTIONS	1-3
1-8.1	REMOVAL OF TOP AND BOTTOM COVERS	1-3
1-8.2	OPTIONAL CRYSTAL FILTERS	1-4
1-8.3	OPTIONAL VOICE SYNTHESIZER, MODEL 257	1-4
1-8.4	OPTIONAL ALC ANNUNCIATOR, MODEL 259	1-4
1-8.5	OPTIONAL REMOTE TUNING ENCODER, MODEL 301	1-4
1-8.6	INTERFACING WITH OTHER TEN-TEC EQUIPMENT	1-5
1-8.7	FREQUENCY STABILITY AT TURN-ON	1-5

2. GETTING STARTED - FRONT PANEL CONTROL SETTINGS

2-1	INTRODUCTION	2-1
2-2	INITIAL FRONT PANEL SETTINGS	2-1
2-3.1	OPERATION	2-2
2-3.2	SSB OPERATION	2-2
2-3.3	CW OPERATION	2-2
2-3.4	FM OPERATION	2-2
2-3.5	OTHER MODES	2-2
2-4.1	A FEW WORDS ON MICROPROCESSORS	2-2
2-4.2	PARTIAL RESET	2-2
2-4.3	MASTER RESET	2-3
2-5	MAIN TUNING KNOB DRAG ADJUSTMENT	2-3

TABLE OF CONTENTS (continued)

<u>PARAGRAPH</u>	<u>PAGE</u>
3. DETAILED OPERATING INSTRUCTIONS	
3-1.00 FRONT PANEL CONTROLS - KEYPAD FUNCTIONS.....	3-1
3-1.01 CHANGING FREQUENCY	3-1
3-1.02 MODE SELECT BUTTONS	3-2
3-1.03 TUNE	3-2
3-1.04 CW (SPOT)	3-2
3-1.05 USB	3-2
3-1.06 LSB	3-2
3-1.07 FSK	3-2
3-1.08 USING AFSK ON THE DIGITAL MODES	3-2
3-1.09 FM	3-3
3-1.10 I-F CRYSTAL FILTER SELECTION	3-3
3-1.11 VOX ADJUSTMENTS	3-3
3-1.12 CLOCK SET	3-4
3-1.13 CW SIDETONE LEVEL ADJUSTMENT	3-4
3-1.14 CW PITCH AND OFFSET ADJUSTMENT	3-4
3-1.15 BUILT-IN IAMBIC KEYER (SPEED & WEIGHTING ADJUSTMENTS) ...	3-4
3-1.16 DIM	3-4
3-1.17 VOICE	3-4
3-2.0 TRANSMIT / RECEIVE FREQUENCY CONTROL.....	3-4
3-2.1 SIMPLEX OPERATION (A/B).....	3-5
3-2.2 SPLIT OPERATION (A=B, SPLIT, REV)	3-5
3-2.3 RIT OPERATION	3-5
3-2.4 XIT OPERATION	3-5
3-2.5 SIMULTANEOUS RIT/XIT OPERATION	3-5
3-2.6 CROSS BAND OPERATION	3-5
3-2.7 MODE SELECT BUTTONS	3-6
3-3.0 THE MEMORY SYSTEM.....	3-6
3-3.1 USING SCRATCH PAD MEMORY	3-6
3-3.2 BAND REGISTERS	3-6
3-3.3 MEMORY STORE.....	3-6
3-3.4 MEMORY RECALL BY CHANNEL NUMBER	3-6
3-3.5 USING MEMORY SCROLL.....	3-6
3-3.6 USING MEMORY TUNE	3-7
3-3.7 AUTOMATIC MEMORY TUNE	3-7
3-3.8 AUTOMATIC BAND SCAN.....	3-7
3-3.9 LOCK	3-7
3-4 USER OPTIONS MENU.....	3-7
3-5.0 OTHER FRONT PANEL CONTROLS.....	3-9
3-5.01 RF OUTPUT POWER (PWR)	3-9
3-5.02 FORWARD AND REFLECTED POWER	3-9

TABLE OF CONTENTS (continued)

<u>PARAGRAPH</u>	<u>PAGE</u>
3-5.03 MIC GAIN ADJUSTMENT	3-9
3-5.04 SPEECH PROCESSOR USE	3-9
3-5.05 -20dB RECEIVER ATTENUATOR	3-9
3-5.06 NOISE BLANKER	3-9
3-5.07 AUTOMATIC GAIN CONTROL (AGC) ON/OFF	3-9
3-5.08 AUTOMATIC GAIN CONTROL FAST/SLOW	3-10
3-5.09 AUDIO (AF) AND RF GAIN CONTROLS	3-10
3-5.10 S-METER	3-10
3-5.11 SQUELCH	3-10
3-5.12 PASS BAND TUNING (PBT)	3-10
3-5.13 USING THE NOTCH SYSTEM	3-10
3-5.14 QSK FAST/SLOW (CW LINEAR RELAY DECAY ADJUSTMENT)	3-10
3-5.15 ANTENNA SWITCH, MAIN/AUXILIARY	3-11
3-6 REAR PANEL CONNECTIONS	3-11
3-6.01 EXTERNAL SPEAKER	3-11
3-6.02 INTERFACE PORT	3-11
3-6.03 MARK/SPACE	3-11
3-6.04 AUDIO IN	3-11
3-6.05 AUDIO OUT	3-11
3-6.06 SERIAL PORT	3-11
3-6.07 POWER	3-11
3-6.08 GND	3-11
3-6.09 TX OUT / TX EN	3-11
3-6.10 MUTE	3-12
3-6.11 PTT	3-12
3-6.12 KEY3-12	
3-6.13 KEYS	3-12
3-6.14 AUX +13.5V	3-12
3-6.15 RELAY {N.O.} (Also Refer to 3-5.14)	3-12
3-6.16 AUX RX ANTENNA	3-12
3-6.17 50 OHM ANTENNA	3-12

4. CIRCUIT DESCRIPTIONS AND ILLUSTRATIONS

4-1 INTRODUCTION	4-1
4-2 DC POWER INPUT BOARD (81591)	4-2
4-3 LOW PASS FILTER BOARD (81592)	4-5
4-4 BPF / FRONT END BOARD (81593)	4-8
4-5 9 MHZ MIXER/I-F BOARD (81594)	4-11
4-6 PASS BAND TUNING BOARD (81600)	4-15
4-7 I-F/AF BOARD (81602)	4-17
4-8 5.0 - 5.5 MHZ PLL BOARD (81599)	4-21

Index

Introduction	1
1. The Problem	1
2. The Method	1
3. The Results	1
4. The Discussion	1
5. The Conclusion	1
6. The Acknowledgments	1
7. The References	1
8. The Appendix	1
9. The Bibliography	1
10. The Glossary	1
11. The Index	1
12. The List of Figures	1
13. The List of Tables	1
14. The List of Equations	1
15. The List of Symbols	1
16. The List of Abbreviations	1
17. The List of Acronyms	1
18. The List of Initials	1
19. The List of Surnames	1
20. The List of First Names	1
21. The List of Middle Names	1
22. The List of Nicknames	1
23. The List of Titles	1
24. The List of Degrees	1
25. The List of Honors	1
26. The List of Awards	1
27. The List of Prizes	1
28. The List of Medals	1
29. The List of Orders	1
30. The List of Decorations	1
31. The List of Honorary Degrees	1
32. The List of Honorary Memberships	1
33. The List of Honorary Fellowships	1
34. The List of Honorary Doctorates	1
35. The List of Honorary Citizenships	1
36. The List of Honorary Residencies	1
37. The List of Honorary Naturalizations	1
38. The List of Honorary Passports	1
39. The List of Honorary Visas	1
40. The List of Honorary Consuls	1
41. The List of Honorary Consuls-General	1
42. The List of Honorary Consuls-Consular	1
43. The List of Honorary Consuls-Trade	1
44. The List of Honorary Consuls-Protective	1
45. The List of Honorary Consuls-Commercial	1
46. The List of Honorary Consuls-Industrial	1
47. The List of Honorary Consuls-Agricultural	1
48. The List of Honorary Consuls-Fishing	1
49. The List of Honorary Consuls-Mining	1
50. The List of Honorary Consuls-Consular-Trade	1
51. The List of Honorary Consuls-Consular-Industrial	1
52. The List of Honorary Consuls-Consular-Agricultural	1
53. The List of Honorary Consuls-Consular-Fishing	1
54. The List of Honorary Consuls-Consular-Mining	1
55. The List of Honorary Consuls-Consular-Commercial	1
56. The List of Honorary Consuls-Consular-Industrial	1
57. The List of Honorary Consuls-Consular-Agricultural	1
58. The List of Honorary Consuls-Consular-Fishing	1
59. The List of Honorary Consuls-Consular-Mining	1
60. The List of Honorary Consuls-Consular-Consular	1
61. The List of Honorary Consuls-Consular-Consular-General	1
62. The List of Honorary Consuls-Consular-Consular-Consular	1
63. The List of Honorary Consuls-Consular-Consular-Consular-General	1
64. The List of Honorary Consuls-Consular-Consular-Consular-Consular	1
65. The List of Honorary Consuls-Consular-Consular-Consular-Consular-General	1
66. The List of Honorary Consuls-Consular-Consular-Consular-Consular-Consular	1
67. The List of Honorary Consuls-Consular-Consular-Consular-Consular-Consular-General	1
68. The List of Honorary Consuls-Consular-Consular-Consular-Consular-Consular-Consular	1
69. The List of Honorary Consuls-Consular-Consular-Consular-Consular-Consular-Consular-General	1
70. The List of Honorary Consuls-Consular-Consular-Consular-Consular-Consular-Consular-Consular	1
71. The List of Honorary Consuls-Consular-Consular-Consular-Consular-Consular-Consular-Consular-General	1
72. The List of Honorary Consuls-Consular-Consular-Consular-Consular-Consular-Consular-Consular-Consular	1
73. The List of Honorary Consuls-Consular-Consular-Consular-Consular-Consular-Consular-Consular-Consular-General	1
74. The List of Honorary Consuls-Consular-Consular-Consular-Consular-Consular-Consular-Consular-Consular-Consular	1
75. The List of Honorary Consuls-Consular-Consular-Consular-Consular-Consular-Consular-Consular-Consular-Consular-General	1
76. The List of Honorary Consuls-Consular-Consular-Consular-Consular-Consular-Consular-Consular-Consular-Consular-Consular	1
77. The List of Honorary Consuls-Consular-Consular-Consular-Consular-Consular-Consular-Consular-Consular-Consular-Consular-General	1
78. The List of Honorary Consuls-Consular-Consular-Consular-Consular-Consular-Consular-Consular-Consular-Consular-Consular-Consular	1
79. The List of Honorary Consuls-Consular-Consular-Consular-Consular-Consular-Consular-Consular-Consular-Consular-Consular-Consular-General	1
80. The List of Honorary Consuls-Consular-Consular-Consular-Consular-Consular-Consular-Consular-Consular-Consular-Consular-Consular-Consular	1
81. The List of Honorary Consuls-Consular-Consular-Consular-Consular-Consular-Consular-Consular-Consular-Consular-Consular-Consular-Consular-General	1
82. The List of Honorary Consuls-Consular-Consular-Consular-Consular-Consular-Consular-Consular-Consular-Consular-Consular-Consular-Consular-Consular	1
83. The List of Honorary Consuls-Consular-Consular-Consular-Consular-Consular-Consular-Consular-Consular-Consular-Consular-Consular-Consular-Consular-General	1
84. The List of Honorary Consuls-Consular-Consular-Consular-Consular-Consular-Consular-Consular-Consular-Consular-Consular-Consular-Consular-Consular-Consular	1
85. The List of Honorary Consuls-Consular-Consular-Consular-Consular-Consular-Consular-Consular-Consular-Consular-Consular-Consular-Consular-Consular-Consular-General	1
86. The List of Honorary Consuls-Consular-Consular-Consular-Consular-Consular-Consular-Consular-Consular-Consular-Consular-Consular-Consular-Consular-Consular-Consular	1
87. The List of Honorary Consuls-Consular-Consular-Consular-Consular-Consular-Consular-Consular-Consular-Consular-Consular-Consular-Consular-Consular-Consular-Consular-General	1
88. The List of Honorary Consuls-Consular-Consular-Consular-Consular-Consular-Consular-Consular-Consular-Consular-Consular-Consular-Consular-Consular-Consular-Consular-Consular	1
89. The List of Honorary Consuls-Consular-Consular-Consular-Consular-Consular-Consular-Consular-Consular-Consular-Consular-Consular-Consular-Consular-Consular-Consular-Consular-General	1
90. The List of Honorary Consuls-Consular-Consular-Consular-Consular-Consular-Consular-Consular-Consular-Consular-Consular-Consular-Consular-Consular-Consular-Consular-Consular-Consular	1
91. The List of Honorary Consuls-Consular-Consular-Consular-Consular-Consular-Consular-Consular-Consular-Consular-Consular-Consular-Consular-Consular-Consular-Consular-Consular-Consular-General	1
92. The List of Honorary Consuls-Consular-Consular-Consular-Consular-Consular-Consular-Consular-Consular-Consular-Consular-Consular-Consular-Consular-Consular-Consular-Consular-Consular-Consular	1
93. The List of Honorary Consuls-Consular-Consular-Consular-Consular-Consular-Consular-Consular-Consular-Consular-Consular-Consular-Consular-Consular-Consular-Consular-Consular-Consular-Consular-General	1
94. The List of Honorary Consuls-Consular-Consular-Consular-Consular-Consular-Consular-Consular-Consular-Consular-Consular-Consular-Consular-Consular-Consular-Consular-Consular-Consular-Consular-Consular	1
95. The List of Honorary Consuls-Consular-Consular-Consular-Consular-Consular-Consular-Consular-Consular-Consular-Consular-Consular-Consular-Consular-Consular-Consular-Consular-Consular-Consular-Consular-General	1
96. The List of Honorary Consuls-Consular	1
97. The List of Honorary Consuls-Consular-General	1
98. The List of Honorary Consuls-Consular	1
99. The List of Honorary Consuls-Consular-General	1
100. The List of Honorary Consuls-Consular	1

TABLE OF CONTENTS (continued)

<u>PARAGRAPH</u>		<u>PAGE</u>
4-9	XTAL OSC.-L.O. MIXER BOARD (81595)	4-25
4-10	CONTROL BOARD (81596)	4-29
4-11	LOGIC BOARD (81606)	4-33
4-12	LED DISPLAY BOARD (81587)	4-37
4-13	LED DISPLAY DRIVER BOARD (81588)	4-39
4-14	TX AUDIO BOARD (81597)	4-43
4-15	LOW LEVEL DRIVER / NOISE BLANKER (81608)	4-47
4-16	POWER AMPLIFIER (81611)	4-51
4-17	FM BOARD (81598)	4-53
4-18	KEYPAD / ENCODER BOARD (81589)	4-55
4-19	SWITCH BOARD (81603)	4-57
4-20	UPPER POT, BOARD (81604)	4-59
4-21	LOWER POT, BOARD (81605)	4-61

* For DB-25 Wiring Information see Figure 26 on Page 4-39

5. OMNI VI SERIAL INTERFACE

5-1	INTRODUCTION	5-1
5-2	COMMAND / CONTROL OPERATIONS OF TEN-TEC TRANS ...	5-2
5-3	COMMAND / DATA FORMATS-COMPUTER TO TRANS	5-2
5-4	RESPONSE STRINGS-RADIO TO COMPUTER	5-3
5-5	DATA FORMATS	5-3
5-6	COMMANDS	5-3
	-SPECIALIZED COMMAND MODES	5-8

6. TROUBLESHOOTING 6-1

LIST OF ILLUSTRATIONS

<u>FIGURE</u>	<u>PAGE</u>
1-1 DC POWER CABLE CONNECTIONS	1-1
1-2 MICROPHONE CONNECTIONS	1-2
1-3 KEYSER PADDLES CONNECTION	1-2
1-4 6.3 MHZ I-F CRYSTAL FILTERS INSTALLATION	1-4
1-5 NARROW CRYSTAL FILTER INSTALLATION	1-4
1-6 VOICESYNTHESIZER INSTALLATION	1-4
1-7 QSK HOOKUP WITH HERCULES II AMPLIFIER	1-6
1-8 QSK HOOKUP WITH CENTURION OR TITAN AMP	1-6
1-9 QSK HOOKUP WITH HERCULES II AND MODEL 253	1-7
AUTOMATIC ANTENNA TUNER	
1-10 HOOKUP WITH NON TEN-TEC AMPLIFIERS	1-8
3-1 MODEL 563 FRONT VIEW	3-13
3-2 MODEL 563 REAR VIEW	3-13
3-3 MODEL 563 TOP VIEW	3-14
3-4 MODEL 563 BOTTOM VIEW	3-15
4-1 DC INPUT BOARD COMPONENT LAYOUT (81591)	4-2
4-2 DC INPUT BOARD SCHEMATIC	4-3
4-3 LOW PASS FILTER BD. COMP. LAYOUT (81592)	4-6
4-4 LOW PASS FILTER BOARD SCHEMATIC	4-7
4-5 BPF/FRONT END BD. COMPONENT LAYOUT (81593)	4-8
4-6 BPF/FRONT END BOARD SCHEMATIC	4-9
4-7 9 MHZ MIXER / I-F BOARD COMP. LAYOUT (81594)	4-12
4-8 9 MHZ MIXER / I-F BOARD SCHEMATIC	4-13
4-9 PBT BOARD COMPONENT LAYOUT (81600)	4-15
4-10 PBT BOARD SCHEMATIC	4-16
4-11 I-F / AF BOARD COMPONENT LAYOUT (81602)	4-17
4-12 I-F / AF BOARD SCHEMATIC	4-19
4-13 5.0-5.5 MHZ PLL BOARD COMP. LAYOUT (81599)	4-21
4-14 5.0-5.5 MHZ PLL BOARD SCHEMATIC	4-23
4-15 XTAL OSC.-L.O. MIXER BD. COMP. LAYOUT (81595)	4-25
4-16 XTAL OSC.-L.O. MIXER BD. SCHEMATIC	4-27
4-17 CONTROL BOARD COMPONENT LAYOUT (81596)	4-30
4-18 CONTROL BOARD SCHEMATIC	4-31
4-19 LOGIC BOARD COMPONENT LAYOUT (81606)	4-34
4-20 LOGIC BOARD SCHEMATIC	4-35
4-21 LED DISPLAY BOARD COMPONENT LAYOUT (81587)	4-37
4-22 LED DISPLAY BOARD SCHEMATIC	4-38
4-23 LED DISPLAY DRIVER BD. COMP. LAYOUT (81588)	4-39
4-24 LED DISPLAY DRIVER BOARD SCHEMATIC	4-41

LIST OF ILLUSTRATIONS(continued)

<u>FIGURE</u>		<u>PAGE</u>
4-25	TX AUDIO BOARD COMPONENT LAYOUT (81597)	4-44
4-26	TX AUDIO BOARD SCHEMATIC	4-45
4-27	L.L. DRIVER / N.B. BD. COMP. LAYOUT (81608)	4-47
4-28	L.L. DRIVER / N.B. BOARD SCHEMATIC	4-49
4-29	POWER AMPLIFIER COMPONENT LAYOUT (81611)	4-51
4-30	POWER AMPLIFIER SCHEMATIC.....	4-52
4-31	FM BOARD COMPONENT LAYOUT (81598)	4-53
4-32	FM BOARD SCHEMATIC.....	4-54
4-33	KEYPAD / ENCODER BD. COMPONENT LAYOUT (81589)	4-55
4-34	KEYPAD / ENCODER BOARD SCHEMATIC	4-56
4-35	SWITCH BOARD COMPONENT LAYOUT (81603)	4-57
4-36	SWITCH BOARD SCHEMATIC	4-58
4-37	UPPER POT BOARD COMPONENT LAYOUT (81604)	4-59
4-38	UPPER POT BOARD SCHEMATIC.....	4-60
4-39	LOWER POT BOARD COMPONENT LAYOUT (81605)	4-61
4-40	LOWER POT BOARD SCHEMATIC	4-62
4-41	MODEL 563 BOARD INTERCONNECTING DIAGRAM.....	4-63
5-1	CONNECTING OF OMNI VI TO COMPUTER.....	5-1
5-2	RS-232 CABLE WIRING CONNECTIONS	5-1

LIST OF TABLES

<u>TABLE</u>		<u>PAGE</u>
3-1	I-F CRYSTAL FILTERS	3-3
3-2	USER OPTIONS MENU	3-8
6-1	TROUBLESHOOTING CHART	6-1

INTRODUCTION

OMNI VI is the culmination of two decades of engineering in high performance HF transceivers.

The OMNI VI features an advanced phase locked loop synthesizer combined with a oven timebase controlled crystal mixed oscillator for superior phase noise performance and stability. A large LED display is used for ease of viewing the operating frequency. Two additional smaller displays for a 24 hour clock and RIT/XIT offset, are included. The OMNI VI also provides 100 duplex memories (stores both VFOs, mode and filter settings), scratch pad memory, band registers, dual VFOs, direct frequency entry as well as single button band change and a built-in Iambic keyer (mode A or B).

The OMNI VI covers all amateur bands, 160 through 10 meters, using CW (with full or semi break-in), SSB (with built-in speech processor), RTTY (true

FSK or AFSK), and FM. Optional crystal filters can be installed in both the 6.3 MHz and 9 MHz I-Fs.

OMNI VI includes Digital Signal Processing (DSP) on the receiver side. This DSP technology provides an Automatic Notch Filter for SSB, a programmable CW transmit Offset, and a CW Digital Lowpass Filter.

Chapter 1 of this manual covers installation and available accessories. Chapter 2 covers basic operation of the transceiver in order to quickly place the OMNI VI in operation. Chapter 3 provides more detailed operating instructions. Chapter 4 provides all of the technical information and schematics. Chapter 5 provides detailed information about the SPORT computer interface. Chapter 6 provides some hints for troubleshooting, should a problem arise.

UNPACKING

Examine your OMNI VI for signs of shipping damage. Should any damage be apparent, notify the delivering carrier immediately, stating the full extent of the damage.

Retain all damaged cartons. Liability for shipping damage rests with the carrier. It is recommended you keep the shipping carton and fillers in the event that storage, moving, or reshipping becomes necessary.

The following hardware and accessories are packed with your OMNI VI. Make sure that you have not overlooked anything.

3 - #35003	Phono Plug
1 - #35057	4-pin Mic Connector
1 - #35263	1/8" Stereo plug for Iambic keyer paddles
1 - #38040	.050" Allen Wrench

1 - #38088	.062" Allen Wrench
1 - #38057	4-pin Power Cable Connector
4 - #41020	Female Terminal Pins
1 - #74020	Warranty Card
1 - #74229	Operator's Manual
1 - #74234	OMNI VI Connections Guide
1 - #86055	DC Power Cord
1 - #27045	Spare 25A AGC fuse

If any of the previous items are missing, contact the repair department at Ten-Tec for replacements:

Repair Department.....	615-428-0364
Switchboard.....	615-453-7172
FAX.....	615-428-4483

Model 563 SPECIFICATIONS

MODES	USB, LSB, CW, FSK OR AFSK, FM built-in.
FREQUENCY RANGE	All ham bands 160 through 10 meters, Twelve 500KHz segments with 30 KHz over-shoot at upper and lower band edges.
DISPLAY	7 digit to 10 Hz resolution, .56" LED, 2 secondary .3" displays for clock, memory channel and offset.
FREQUENCY CONTROL	LO generated with a crystal oscillator mixed with a low noise 4.97 - 5.53 MHz phase locked loop.
OFFSET TUNING	+/- 9.99 KHz, receive and transmit.
DUAL VFOs	with SPLIT mode
MEMORIES	100 duplex memories, one scratch pad memory (battery backup, 2-3 yr life)
PC INTERFACE	Serial port operation of receive and transmit. Includes two line and RS-232 interface. Runs at 1200, 2400, 4800, 9600, or 19200 baud.
FREQUENCY ACCURACY	+/- 50 Hz @ 25 degrees C. (NOTE: The frequency will shift noticeably for 1-2 minutes while the oven heats up when first turned on. Leave power supply on to eliminate the drift.
ANTENNA	50 ohm unbalanced
REMOTE BAND SWITCHING	Selects antenna or other station accessories.
POWER REQUIRED	2 A receive, 20 A transmit @ 12 - 14 VDC
CONSTRUCTION	20 G10 epoxy glass PC boards, most field replaceable. Extruded aluminum front panel, aluminum chassis, texture painted top & bottom, snap up stainless steel bail.
DIMENSIONS	HWD 5.75" x 14.75" x 17" - 14.6 x 37.5 x 43.2 cm
WEIGHT	16 lbs - 7.25 kg.
TRANSMITTER	
RF OUTPUT	0 - 100 watts, ALC stabilized
DC INPUT	Maximum 250 watts @ 14 VDC. 100% duty cycle for up to 20 minutes. Continuous duty with customer supplied air cooling of rear panel heat sink.
MICROPHONE INPUT	200 - 50K Ohms, accepts microphones with 5mV (-62dB) output. Polarizing voltage for electrets provided.
SPEECH PROCESSOR	Adjustable compression level
T/R SWITCHING	PTT or VOX or SSB, switchable FAST or SLOW QSK on CW, delay on SLOW is adjustable.
IAMBIC KEYER	adjustable 10 - 60 WPM, type A or B, weight adjustable from keypad.
CW OFFSET	programmable 400 - 990 Hz, DSP generated, sidetone automatically matches offset, volume adjustable independent of AF gain control.

FM DEVIATION	+/-5KHz
METERING	Switchable to forward power, SWR, collector current or audio processing level on SSB.
SSB GENERATION	Balanced modulator followed by 9 MHz, 8 pole crystal ladder filter.
CARRIER SUPPRESSION	60 dB typical
UNWANTED SIDEBAND SUPPRESSION	60 dB typical at 1.5 KHz tone.
THIRD ORDER INTERMOD	30 dB below two tone at 100 watts PEP.
SPURIOUS OUTPUT	Better than 45 dB below peak power output.

RECEIVER

SENSITIVITY

FREQUENCY MODE	MHz	1.8-29.7	
SSB, CW, FSK		.15 μ V	10dB S/N
FM		.30 μ V	12dB SINAD

SELECTIVITY

SELECTED FILTER	SELECTIVITY	-6 dB	-60 dB	Shape factor
STANDARD 2.4 KHz		2.4 KHz	4.50 KHz	1.87 : 1
OPTIONAL 1.8 KHz		1.8 KHz	3.40 KHz	1.89 : 1
OPTIONAL 500 Hz		500 Hz	1.40 KHz	2.80 : 1
OPTIONAL 250 Hz		250 Hz	850 Hz	3.40 : 1
STANDARD FM		15.0 KHz	30.0 KHz	2.00 : 1

DYNAMIC RANGE	97 dB @ 2.4 KHz bandwidth at 20 KHz spacing, 100 dB + with CW filters.
THIRD ORDER INTERCEPT	+ 10dBm
NOISE FLOOR	-133 dBm @ 2.4 KHz bandwidth
PHASE NOISE	-122 dBc @ 1 KHz, -138 dBc @ 20 KHz.
S-METER	Calibrated to 50 μ V at S9.
ATTENUATOR	-20 dB
PASSBAND TUNING	+/-1.2KHz
I-F FREQUENCIES	1st I-F 9 MHz, 2nd I-F 6.3 MHz (passband tuning IF), 2nd I-F for FM 455 KHz.
NOISE BLANKER	Adjustable threshold
AUTOMATIC DSP NOTCH FILTER	Eliminates multiple heterodynes, notch depth automatically selected for each.

MANUAL NOTCH FILTER	250 Hz TO 2.2 KHz, greater than 50 dB Adjustable center frequency.
CW DSP FILTER	Low pass audio filter selectable in 5 steps, 1400 Hz, 1200 Hz, 1000 Hz, 600 Hz, or may be disengaged.
RECEIVE RECOVERY TIME	less than 20 ms including split mode
SQUELCH SENSITIVITY	Less than .6 μ V
IMAGE REJECTION	> 90dB
I-F REJECTION	> 90dB
AUDIO	1.5 watts @ 4 ohms with less than 2% distortion, built-in speaker, separate fixed output 1 mw @ 600 ohms.
SEPARATE RX ANTENNA INPUT	50 ohm phono jack, front panel selectable.

CHAPTER 1

INSTALLATION

1-1 POWER SUPPLY The matching Ten-Tec power supply, Model 961, is recommended. This supply has over-voltage protection, over current protection and RFI bypassing built in. The speaker, located in the front panel, can be used instead of the OMNI VI internal speaker.

Model 961 power supply is terminated with a 4-pin plug that connects directly to the OMNI VI rear panel. This plug is keyed and will insert only one way. The 1/4" speaker plug is plugged into the EXTERNAL SPEAKER jack on the OMNI VI rear panel to disable the OMNI VI speaker and activate the Model 961 speaker.

Any source of well filtered and regulated DC power may be used. Operating Voltage is +12 to +15 Vdc with an optimum source of +13.8 Vdc at 22 amps.

If alternate power sources are used, terminate the dc supply cable as shown in FIGURE 1-1, using the connector supplied in the transceiver packing kit.

WARNING: Do not connect 120/220 VAC to pins 1 or 4. Serious damage will result and void warranty!!

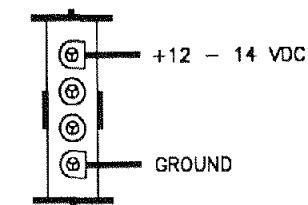

REAR VIEW OF TRANSCEIVER

FIGURE 1-1
DC POWER
CABLE CONNECTIONS

NOTE: ALWAYS ENABLE THE POWER SOURCE FIRST AND THEN THE TRANSCEIVER.

If a storage battery is used, our Model 1140 circuit breaker/power switch is recommended.

IF THE SYSTEM IS SUPPORTED BY A GENERATOR OR ALTERNATOR, ALWAYS START THE RECHARGING DEVICE BEFORE TURNING ON THE TRANSCEIVER. THIS ALLOWS THE VOLTAGE TO STABILIZE. WHEN SHUTTING DOWN, TURN THE TRANSCEIVER OFF FIRST. SERIOUS DAMAGE TO THE TRANSCEIVER CAN OCCUR IF THIS SEQUENCE IS NOT FOLLOWED.

1-2 ANTENNAS The transmitter is protected against damage from load impedances ranging from a dead short to an

open circuit. Operation at, or near, full power is allowed with an unbalanced (coax fed) load impedance of 25 to 100 ohms or an SWR up to 2:1. Antennas with higher SWR, or single wire and balanced feed-line types, will require the use of an external tuner for best results.

NOTE: WHEN OPERATING THE TRANSMITTER INTO A SWR HIGHER THAN 2:1, ADJUST THE RF "PWR" CONTROL TO A COLLECTOR (Ic) CURRENT NOT TO EXCEED 20 AMPS AS INDICATED ON THE FRONT PANEL METER.

The transmitter output is always through the SO-239 coax connector on the rear panel. In most installations, this is also the antenna input to the receiver. The front panel antenna (ANT) switch must be set to MAIN. If a separate antenna is used for receive, it is connected to the rear panel phono jack AUX RX ANTENNA. Both antennas can be connected at all times. Select the desired receive antenna with the front panel antenna switch.

1-3 MICROPHONE Any TEN-TEC microphone, using our 4 pin connector, may be used without modification. Any dynamic, ceramic, crystal or electret type microphone, with an impedance of 200 to 50,000 ohms, may be used. Electret types, and some with built-in pre-amplifiers, require dc voltage. This is available at the MIC input connector, as shown in Figure 1-2. The mike cable must be shielded to prevent RF feedback. A connector is supplied in the packing kit.

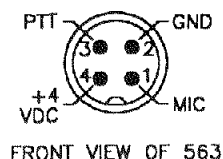

**FIGURE 1-2
MICROPHONE CONNECTION**

1-4 CW KEY An Iambic keyer is built-in with speed adjustment using the front panel KEYSER SPEED control. Keyer weighting is factory configured for a 3:1 dot/dash ratio and is adjustable. See chapter 3, Sections 3-1.15 and 3-4 for more details along with instructions to select keyer type A or B. Any paddle type designed for use with an electronic keyer may be used. Connection is through a standard 1/8" stereo headphone plug (in packing kit) as shown in Figure 1-3. This plugs into the rear panel KEYSER jack.

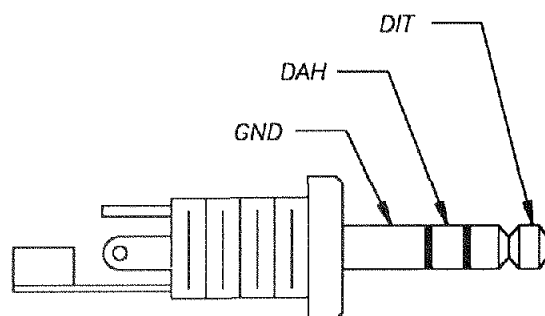

**FIGURE 1-3
BUILT-IN ELECTRONIC KEYSER
CONNECTION**

An external keyer may be used through the rear panel KEYSER jack. This circuit simply requires key closure to transmit.

1-5 STATION GROUND A good ground system is essential for optimum operation of any transmitter. The best practical system is to bond all station equipment together and make a single

point connection to a buried eight foot ground rod. Use a heavy flat braid conductor, as short as possible. If you are not using a linear amplifier a less ideal ground may suffice. Grounding to the copper cold water supply line is usually acceptable.

Antenna type and proximity to the station is also a factor. If the antenna is reasonably positioned, away from the station, the electrical supply ground system may be adequate. Suspect your station ground system if experiencing RFI problems.

1-6 CONNECTING OTHER ACCESSORY EQUIPMENT Provisions have been included to interface many station accessories: digital equipment, linear amplifiers, TV and computers. See the Table of Contents to locate detailed information. If connecting a non Ten-Tec amplifier refer to Figure 1-11 and Section 3-6.15.

1-7 TEN-TEC ACCESSORIES FOR OMNI VI

- 216----500 Hz 6 Pole FSK Filter, 9 MHz
- 217----500 Hz 8 Pole Ladder Filter, 9 MHz
- 218----1.8 KHz 8 Pole Ladder Filter, 9 MHz
- 219----250 Hz 6 Pole Ladder Filter, 9 MHz
- 220----2.4 KHz 8 Pole Ladder Filter, 9 MHz
- 236----Remote Control Cable for connecting to either a Model 253 or Model 420
- 238----2 Kw Manual Antenna Tuner
- 239----Dummy Load
- 257----Voice Synthesizer
- 259----Universal ALC Annunciator
- 264----236 Expansion Cable for connecting Model 253/420 combination to OMNI-VI

- 282----250 Hz 6 Pole Ladder Filter, 6.3 MHz
- 285----500 Hz 6 Pole Ladder Filter, 6.3 MHz
- 288----1.8 KHz 8 Pole Ladder Filter, 6.3 MHz
- 301----Remote Frequency Tuning Control
- 305----Serial Level Converter
- 607----Single Paddle Assembly
- 700C--Handheld Mike., Electret with Coiled Cord and 4 Pin Connector
- 705----Desk Mike, Electret, with Coiled Cord and 4 Pin Connector
- 961----Power Supply, 115/230 VAC, 13.8 VDC, 22 A, built-in Speaker
- 1140--DC Circuit Breaker/ Power Switch
- 5061---Lowpass Line Filter
- 35057--4 Pin Microphone Connector
- RM-500--Rack mount kit
- 80-572----Spare, 4 Pin DC Connector

1-8 INSTALLING INTERNAL OPTIONS All accessory crystal filters, Model 257 Voice Synthesizer and Model 259 ALC Annunciator mount inside the OMNI VI. Refer to the following paragraphs to remove top and bottom covers and install the desired option(s).

1-8.1 REMOVAL OF TOP & BOTTOM COVERS To remove the top cover, remove the upper two of the four (4) large Phillips screws located on each side. Slide the top back and out from under the rear lip of the extruded front panel.

To remove the bottom cover, remove the lower two (2) large Phillips screws on each side. With the transceiver upside down and the front panel facing forward, slide the bottom cover back and out from underneath the rear lip of the extruded front panel.

1-8.2 OPTIONAL CRYSTAL FILTERS Up to four (4) optional crystal filters may be installed in the OMNI VI. The Model 288 (1.8 KHz), Model 285 (500 Hz), and Model 282 (250 Hz) filters may be installed in the 6.3 MHz I-F as shown in FIGURE 1-4. These optional filters install on the Pass Band Tuning Board (81600) located on the bottom side of the transceiver. The filters may be installed in either direction.

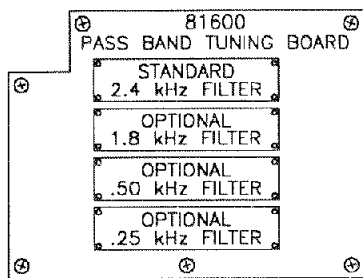

**FIGURE 1-4
6.3 MHz I-F CRYSTAL FILTER
INSTALLATION**

A fourth optional crystal filter may be installed on the 9 MHz Mixer/I-F Board (81594) and is selected by pressing the "NAR." (narrow) button on the front panel. One of the four following filters may be installed: Model 218 (1.8 KHz), Model 217 (500 Hz), Model 219 (250 Hz), and Model 216 (500 Hz filter for RTTY). The filter gain must be selected by using the GAIN SELECT jumper. Refer to FIGURE 1-5.

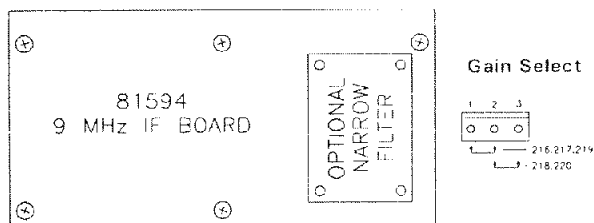

**FIGURE 1-5
NARROW CRYSTAL FILTER
INSTALLATION**

1-8.3 OPTIONAL VOICE SYNTHESIZER, MODEL 257

The Voice synthesizer announces the display frequency when the VOICE button is pressed. The Voice board plugs into an edge card connector on the Logic Board. Refer to FIGURE 1-6 for the location of the edge card connector.

After installing it, press the VOICE button and adjust the speech level control, located on the Voice synthesizer board, to a suitable level. For more detailed information, refer to the Model 257 instruction manual.

NOTE: If voice does not function, check voice board for diode, D1 (1N4148) near edge connector on front left side. If diode is installed, jumper across it. If not, contact factory for assistance

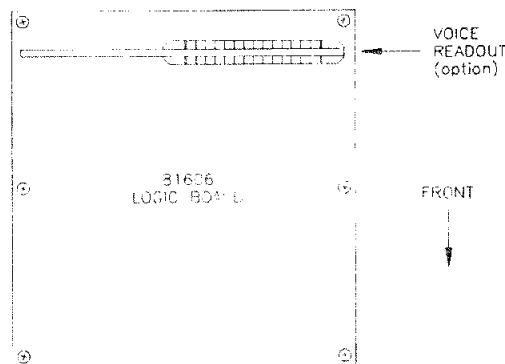

**FIGURE 1-6
VOICE BOARD INSTALLATION**

1-8.4 OPTIONAL ALC ANNUNCIATOR, MODEL 259 This accessory allows the vision impaired operator to adjust the MIC GAIN control properly. For installation instructions refer to the Model 259 manual.

1-8.5 OPTIONAL REMOTE TUNING ENCODER, MODEL 301 The Model 301 Remote Encoder will allow remote tuning of the OMNI VI operating

frequency. This option merely plugs into the DB-25 connector on the OMNI VI rear panel or the short jumper of the Model 236 Remote Control cable. If a computer is already connected to either the rear panel DB-25 connector or the Model 236 cable, then a "Y" adaptor can be installed so the Model 301 and the computer can be used simultaneously. This "Y" cable must be supplied by the customer.

1-8.6 INTERFACING WITH OTHER TEN-TEC EQUIPMENT When connecting other Ten-Tec equipment such as an amplifier or automatic tuner, refer to Figures 1-8, 1-9, or 1-10 on the following pages for connecting diagrams.

1-8.7 FREQUENCY STABILITY AT TURN-ON OMNI VI transceivers made after April 1993 incorporate a feature to keep the crystal oven on for improved frequency stability. To activate this feature, leave the radio power supply ON, when radio is off. If this feature is not desired turn the power supply OFF.

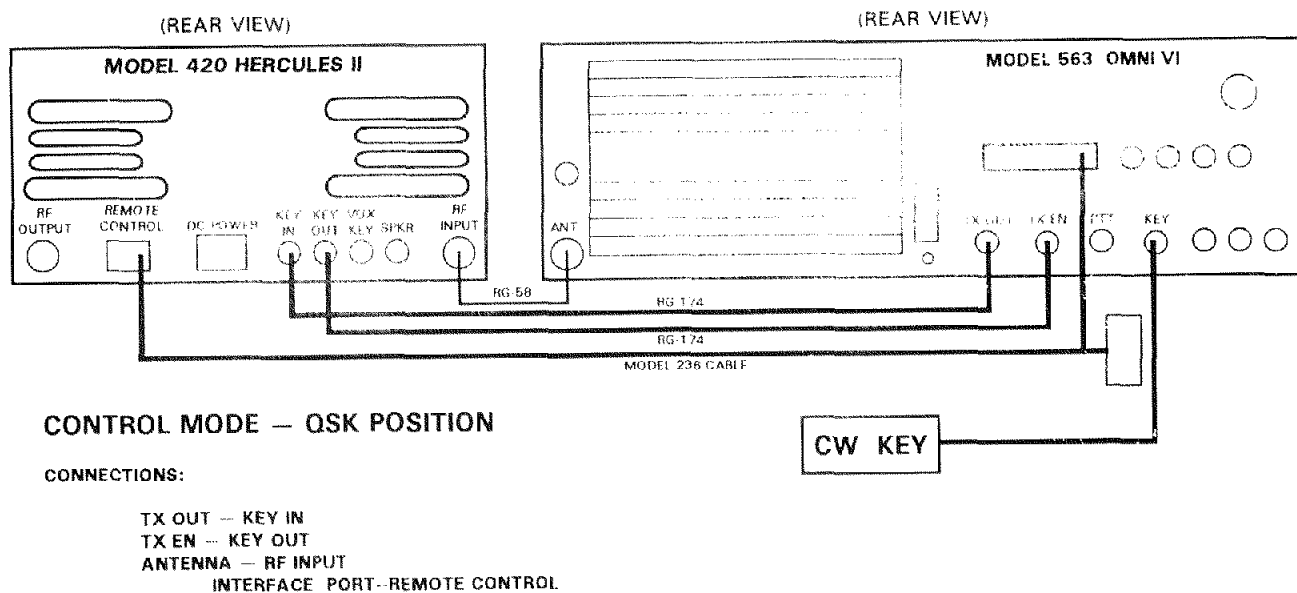

FIGURE 1-7. QSK HOOK-UP WITH HERCULES II AMPLIFIER

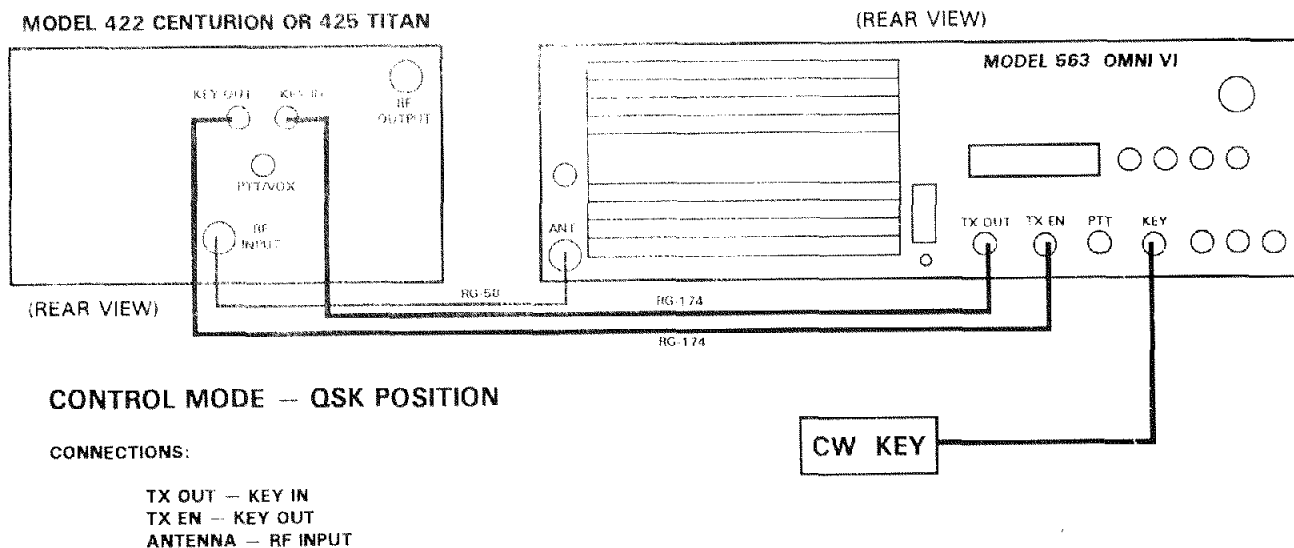
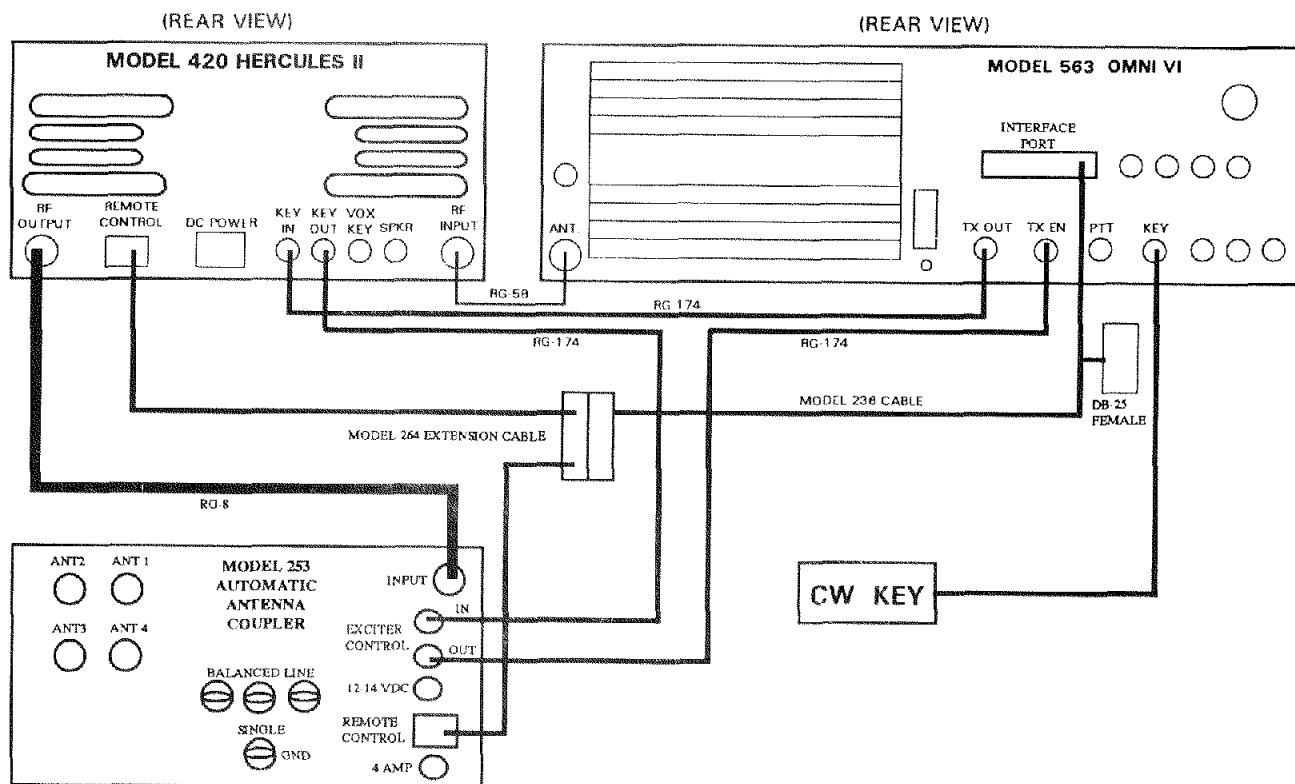

FIGURE 1-8. QSK HOOK-UP WITH CENTURION OR TITAN AMPLIFIER



CONTROL MODE — QSK POSITION

CONNECTIONS:

- TX OUT — KEY IN
- TX EN — KEY OUT
- ANTENNA — RF INPUT
- INTERFACE PORT—REMOTE CONTROL

FIGURE 1-9. QSK HOOK-UP WITH HERCULES II AMPLIFIER

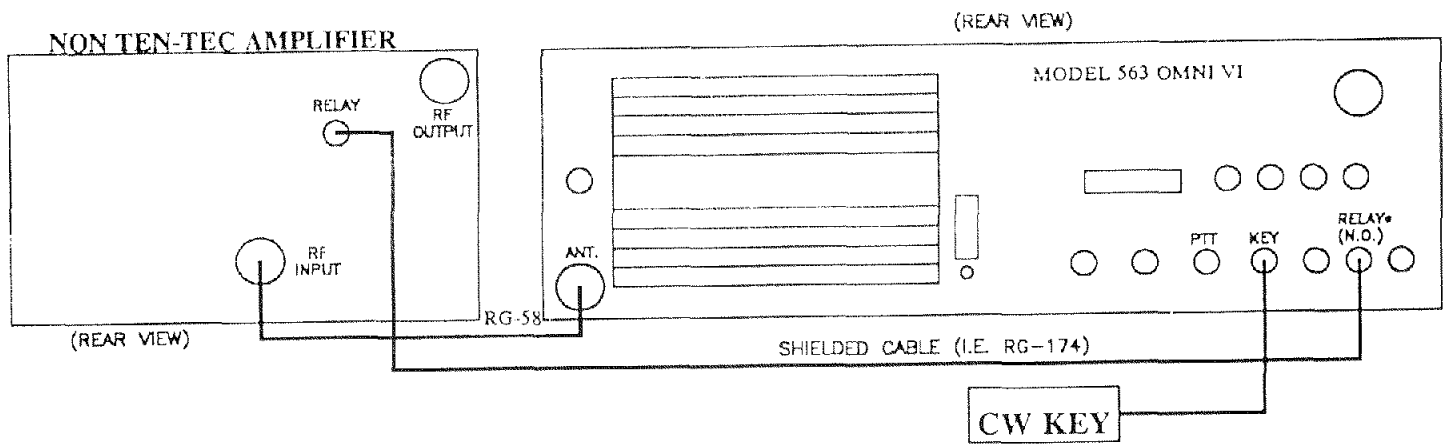

* MUST ACTIVATE RELAY VIA USER'S MENU.
SEE SECTION 3-4 (LCD-ON)

FIGURE 1-10. HOOK-UP WITH NON TEN-TEC AMPLIFIERS

CHAPTER 2

GETTING STARTED

2-1 INTRODUCTION Virtually all adjustments are controlled from the front panel. This includes "set and forget" controls such as VOX and CW sidetone. Control capability has been added to satisfy operator preferences even if your preference is in the minority. Frequency selection priorities (band switching vs. discreet frequency entry) are operator selectable. CW transmit offset is adjustable and includes automatic sidetone frequency tracking. All operator options are explained in detail in Chapter 3. The factory settings or "default" values will allow you to get started. You can customize operation to more closely fit your preferences as you become more familiar with the transceiver.

BEFORE YOU POWER UP

The first time you power up the OMNI VI we strongly suggest a MASTER RESET of the microprocessor as explained in Section 2-4.3.

When power is first applied, you will observe noticeable frequency drift for 1-2 minutes as the internal oven comes up to temperature. If the power supply is left on, no drift will occur. See Section 1-8.7

2-2 INITIAL FRONT PANEL SETTINGS:

RF..... Full clockwise
AF..... 9:00

POWER ON
METER FWD
ANT..... MAIN
AGC ON
AGC FAST
NOTCH MANUAL (no light)
QSK..... FAST
ATTN..... OFF (no light)
N.B..... Full counter clockwise
SQL Full counter clockwise
PBT 12:00
NOTCH..... Full counter clockwise
RIT/XIT..... Ignore for now
PROC OFF (no light)
MIC 9:00
PWR 12:00
KEYER SPEED Full counter clockwise
PROCESSOR... Full counter clockwise
VOX OFF (no VOX light, upper display)
SELECT DESIRED MODE
.....CW,LSB,USB,FSK,FM
SELECT VFO "A"....use A/B button, if VFO B active
SPLIT..... OFF (no SPLIT light in upper display)
RIT OFF (no Numeric offset displayed, no light)
XIT..... OFF (no offset displayed, no light)
LOCK..... OFF (no light)
SELECT DESIRED BAND....Use band buttons
SELECT FREQUENCY....Use main tuning knob or UP/DOWN Arrow keys
I-F FILTER..... Select 2.4, NAR off (no light)

2-3.1 OPERATION Before transmitting, connect a suitable resonant antenna. Press TUNE and adjust FWR to desired level, up to 100 watts. If full clockwise control results in less than 100 watts, switch METER to collector current (Ic) and set to 20 amps or less. Check reflected power with SWR position on meter switch. A SWR of 2:1 (10% of forward power) or less is recommended.

2-3.2 SSB OPERATION Select either LSB or USB. Key mike PTT button and, while speaking into the mike, adjust MIC control so that the ALC LED blinks on voice peaks. Tune to a SSB signal. Adjust the PBT if there is bothersome interference on the receive signal. You are now ready to operate SSB, full transceive, simplex. To fine tune the receive frequency without changing the transmit frequency, turn RIT on and use the RIT/XIT control. To quickly return the receiver to the exact transmit frequency, turn RIT off or hold RIT button in for 1 second. See Chapter 3, Section 1.11, for VOX operation and adjustments.

2-3.3 CW OPERATION Select CW mode. When your cw key is closed you are transmitting. With key open you are in receive, simplex. The built-in electronic keyer is adjusted with the front panel KEYSPEED control. If you do not want fast break-in CW, switch QSK to SLOW. See Chapter 3, Section 3-1.15, for KEYSPEED weighting and Section 3-5.14 for QSK-SLOW delay adjustments. The rear panel PTT jack can also be used for CW transmit control. If narrow filters have been installed, select the one of your choice and then adjust PBT for best results. See SSB paragraph above for RIT operation.

2-3.4 FM OPERATION Select FM mode. (NOTE: This mode currently authorized for use from 29.0 to 29.7 MHz only). Adjust squelch (SQL) for receiver quieting when no signal is present. Press mike PTT switch to transmit. In this mode, MIC gain is converted to a FM deviation control. Set MIC gain to 12:00 when using a TEN-TEC mike. You may find a slightly higher or lower setting is needed with other microphones.

The narrow I-F filters and PBT are not active in the FM mode. There are repeaters in use with split input and output frequencies. To set up for these, select VFO B, (using A/B button), and tune to the transmit frequency. Select VFO A and tune to the receive frequency. Press SPLIT. Split frequency pairs can be stored in any of the 100 memories. (See Chapter 3, Sections 3-2.2 and 3-3). To return to simplex operation, turn SPLIT off.

2-3.5 OTHER MODES such as the digital modes and ATV, see Chapter 3 and the manuals supplied with the accessory equipment.

2-4.1 A FEW WORDS ON MICRO-PROCESSORS On rare occasions you may find the transceiver will not accept commands from the keypad properly or it is operating in an erratic manner. Spikes or surges on the power supply line or an unforeseen set of circumstances may confuse the microprocessor. This technology has improved dramatically in recent years but it is still possible to have an occasional lockup. If turning POWER off and on does not resolve problem, the microprocessor must be reset using one of the following methods.

See Figure 3-1 for location of the controls referred to in the following paragraphs.

2-4.2 PARTIAL RESET Always try this method first as it will not erase memories or selections from USER OPTIONS MENU. Turn off POWER. Press and hold CLEAR button and turn POWER on. Continue to hold CLEAR for several seconds and release. If this does not return transceiver to normal operation use a MASTER RESET.

2-4.3 MASTER RESET This will erase all memories and return USER OPTIONS MENU to factory presets. Turn off POWER. Press and hold ENTER button and turn POWER on. Continue to hold ENTER for several seconds and release.

2-5 MAIN TUNING KNOB DRAG ADJUSTMENT To adjust drag on main tuning knob, hold the rear silver skirt and turn the main knob body CCW to loosen and CW to tighten. If the knob seems to "wobble", the rear skirt can be moved slightly from one side to the other to make the knob concentric.

CHAPTER 3

DETAILED OPERATING INSTRUCTIONS

3-1.00 FRONT PANEL CONTROLS-KEYPAD FUNCTIONS

(See Figure 3-1) Single button selections such as band, mode, I-F filters, VFO selection and RIT/XIT options are the ones you will use routinely. All are well marked and supported with status lights. Multi-stroke keypad functions are used for less frequently used features or to customize the transceiver to fit your personal preferences. These options are explained in the following sections. These functions tend to be "set and forget" beyond experimenting during the initial setup. Every effort has been made to allow you to optimize your transceiver whether you operate one mode or enjoy all of them.

When making these initial adjustments, be sure to select the proper mode and frequency. We also recommend the use of a 50 ohm dummy load (Model 239), capable of at least 100 watts, during this setup procedure.

NOTE: ANY OF THESE MULTIPLE KEY COMMAND SEQUENCES CAN BE ABORTED BEFORE COMPLETION BY PRESSING THE CLEAR BUTTON.

3-1.01 CHANGING FREQUENCY

There are four methods of changing frequency or bands:

1) Tune up or down the band with the main tuning knob. The knob tunes at a default rate of 5.12 KHz per revolution.

Other rates are selectable by the user. Refer to Section 3-4. *NOTE: THIS FEATURE WAS ADDED TO UNITS PRODUCED AFTER AUGUST 1993.*

FEATURE CAN BE ADDED TO EARLIER UNITS FOR A NOMINAL FEE - CONTACT FACTORY FOR DETAILS.

2) Move up or down a band quickly in 100 KHz steps using the UP or DOWN arrows on the keypad.

3) Change from band to band by pressing the desired band button.

4) Move to a particular desired frequency by entering it directly on the keypad as outlined below:

Press ENTER (Display now shows dashes). Type in desired frequency. It is not necessary to enter every number down to the 10 Hz. digit. Pressing ENTER at any point will fill remaining segments with zero.

Example 1: Desired frequency 14.200.00. Press ENTER, 1, 4, 2, ENTER.

Example 2: Desired frequency 3.786.55. Press ENTER, 3, 7, 8, 6, 5, 5. (It was not necessary to hit ENTER to complete the sequence).

Example 3: Desired frequency 1.890.00. Press ENTER, 0, 1, 8, 9, ENTER. (NOTE: To enter a frequency on 160M, a "zero" must precede the "one".)

The numerical keypad functions as a single button bandswitch as shipped from the factory. To enter an exact frequency, you must press ENTER, then the frequency, as explained in the previous

examples. This feature may be reversed in the USER'S OPTIONS MENU with the FEP option (Frequency Entry Priority). If reversed, you must press ENTER to bandswitch and an exact frequency can be typed without the ENTER key to start the sequence. Refer to Section 3-4 for details.

3-1.02 MODE SELECT BUTTONS

3-1.03 TUNE Pressing TUNE activates the transmitter, in the CW mode, key down. Power output is adjusted with the PWR control, independent of MIC gain. This mode is a convenient way to set output power, check SWR and collector current.

3-1.04 CW Selects CW mode. All I-F filters are usable. The CW DSP Low Pass filter is also activated if you have programmed it in the USER OPTIONS MENU, see Section 3-4 (LP). First, make certain the NOTCH filter is in manual and the NOTCH control at the maximum counter clockwise position. If a CW paddle is connected through the rear panel KEYER jack, key closure operates the built-in electronic keyer which keys the transmitter. If a standard external key or keyer is connected through the rear panel KEY jack, closure keys the transmitter. The CW button becomes the SPOT button after CW is selected. Press and hold CW to turn on the CW reference tone. Tune the main tuning knob so the received signal matches the tone of the reference. Your transmit frequency is now matched precisely to the received signal. To change the sidetone pitch refer to Section 3-1.14.

3-1.05 USB Selects upper sideband mode. All I-F filters are selectable but

only 2.4 and 1.8 KHz filters are usable on SSB. Narrow filters, 500 and 250 Hz, are usable for the digital modes using AFSK.

3-1.06 LSB Selects lower sideband mode. All I-F filters are selectable but only 2.4 and 1.8 KHz filters are usable on SSB. Narrow filters, 500 and 250 Hz, are usable for the digital modes using AFSK. LSB is normally used on AFSK transmit for the proper shift orientation.

3-1.07 FSK Selects operation in the digital modes and enables the built-in frequency shift keying circuit. The FSK circuitry is controlled through the rear panel MARK/SPACE connector. This input is typically connected to the FSK output jack of a modem or terminal unit. The logic levels required at the MARK/SPACE input are less than or equal to 1.0 Vdc for MARK condition and equal to or greater than 2.0 Vdc for SPACE. This input includes its own pull-up resistor with an open circuit voltage of about 3.5 Vdc. Either a standard TTL level or open collector output line will drive the MARK/SPACE input.

During receive, the FSK mode receives LSB and all of the I-F filters are selectable.

3-1.08 USING AFSK ON THE DIGITAL MODES Virtually all available digital systems include an AFSK generator that can be patched into the microphone input of the transceiver, using a SSB mode. This system works well but there are some "hazards." The correct shift direction is normally obtained in the LSB mode. Switching to USB will reverse the shift. There is usually a reverse switch on the digital system. Set this to copy incoming signals with the transceiver in LSB. The greatest hazard

is to generate phantom signals by overdriving the transmitter. Turn the PWR control full counter clockwise and transmit a string of RYRYRYRY or any other text. Adjust the MIC gain control so that the ALC light barely blinks. Then adjust the PWR control to the desired output.

NEVER USE SPEECH PROCESSING ON AFSK.

Install a PTT control line. Do not use the VOX system. VOX is not fast enough, especially for AMTOR mode. The connections for PTT, AUDIO IN and AUDIO OUT are all available on the rear panel.

NOTE: THE REAR PANEL AUDIO INPUT AND FRONT PANEL MIC JACK ARE IN PARALLEL. WHEN OPERATING AFSK, MAKE SURE THE MIKE IS NOT LIVE. WHEN OPERATING SSB, MAKE CERTAIN THE AFSK SYSTEM IS TURNED OFF OR DISCONNECTED.

3-1.09 FM Selects the FM mode. The I-F filter defaults to the 15 KHz filter which is part of the built-in FM circuit. The narrow I-F filters and PBT are not active. Adjust SQL (squelch) for receiver quieting when no signal is present. Press mike PTT switch to transmit. In FM mode, MIC gain is converted to a FM deviation control. Set MIC to 12:00 when using a TEN-TEC mike. You may find a slightly higher or lower setting is needed with other microphones.

3-1.10 I-F CRYSTAL FILTER SELECTION There are provisions for 4 plug-in filters (3 are optional) in the 6.3 MHz I-F and all are front panel selectable. The 2.4 KHz filter is standard.

This, and all optional filters, are selected with the buttons marked with the filter bandwidth. An additional filter can be installed in the 9 MHz I-F. This is selected with the NAR button and can be cascaded with the same bandwidth or narrower 6.3 MHz filter.

NOTE: 500 Hz and 250 Hz optional filters are centered for receiving CW at a 700 Hz beat note. CW operators who select a CW transmit offset other than 700 Hz. (Refer to Section 3-1.14 and 3-5.12) must use the PBT (passband tuning) control to bring received CW signal, back to center of passband for maximum received signal strength.

Bandwidth selection is independent of mode, except in FM. When the FM mode is selected, the built-in 15 KHz filter is used and all others turned off, automatically. See the chart below for additional filter details.

MODE	SUGGESTED FILTERS	
	6.3MHz	9.0MHz (NAR)IF
USB	2.4, 1.8	1.8
LSB	2.4, 1.8	1.8
CW	.50, .25	.50
FSK	.50	.50(RTTY)

TABLE 3-1. I-F CRYSTAL FILTERS

3-1.11 VOX ADJUSTMENTS Press VOX button. VOX light to the right of the meter is now on. Press GN (Gain) button. The clock display will change to a 2 digit display between 01-15. Use UP/DOWN buttons to make all VOX adjustments. The system is interactive so adjust for desired transmitter action while speaking into the mike. Once you have it set, press ENTER. Now press DLY (VOX delay) and adjust for desired transmitter hang time. Press ENTER. Finally, press AV (Anti-Vox). Tune to an incoming signal and adjust receive

audio level slightly higher than normal. Adjust AV so that the receiver audio does not trip the transmitter. Press ENTER. All adjustments will be stored to memory and the clock display restored to normal operation.

3-1.12 CLOCK SET Press CLK (clock) button and hold for 1 second. The hours display will start to blink. Use the UP/DOWN buttons to select the desired hour. Press ENTER. The minutes display is now blinking. Use the UP/DOWN buttons to select desired minutes. Press ENTER. The clock will start counting from that point. If clock resets when power is turned off, replace the lithium backup battery on the Logic Board (81606).

3-1.13 CW SIDETONE LEVEL ADJUSTMENT Press ST (sidetone) button. Use UP/DOWN buttons to adjust level between 00-31 on the upper right hand display. Press ST again to store value. Sidetone is always enabled when the CW mode is selected, unless the level is turned all the way down.

3-1.14 CW PITCH AND OFFSET ADJUSTMENT As shipped from the factory, the standard frequency offset between transmit and receive is 700 Hz. Some CW operators use a different offset because of personal preference or as a tool when chasing DX.

Press ST (sidetone) button. Use RIT/XIT knob to select the transmit offset frequency from 400-990 Hz as shown on the lower right hand display. Press ST again to store value.

3-1.15 BUILT-IN IAMBIC KEYS

Connect keyer paddle as explained in Chapter 1, Section 1-4. Use front panel KEYSPEED control to adjust to desired speed from 10 - 60

WPM. Keyer weighting is factory set for a 3:1 dot/dash ratio and is adjustable. Press ST and release, then press CW and release. The lower right hand display now shows a relative indication of 1.00 (equivalent to 3:1 dot/dash ratio). Use the UP/DOWN buttons to adjust weighting from .7 to 1.3 on the display.

Press ENTER to save. Note that the upper right hand display shows the present keyer speed and can be adjusted by the KEYSPEED control. As you adjust speed, display will not be updated to the new setting until you stop sending CW for a moment. Keyer is factory set for a CURTIS type A configuration. It may be changed to a type B in the USER OPTIONS MENU. See Section 3-4 (I code.)

3-1.16 DIM This button selects the desired level of display brightness. Press DIM button. Use UP/DOWN buttons to select intensity between 0-15. Press DIM to store.

3-1.17 VOICE If optional Model 257 Voice Synthesizer is installed, pressing VOICE button will cause a voice announcement of frequency shown on main display.

3-2.0 TRANSMIT/RECEIVE FREQUENCY CONTROL In addition to normal simplex operation (RX and TX on same frequency) there are three methods of operation that allow independent control of transmit and receive frequencies. All three allow cross band operation, with reduced QSK speeds. You

will most likely choose one system that best matches your operating interests and techniques. We encourage you to learn all three systems.

3-2.1 SIMPLEX OPERATION Select VFO A or B (A/B button) and select frequency, mode and filter choice. Make sure that SPLIT, RIT and XIT are all off.

3-2.2 SPLIT OPERATION Remember that VFO A and VFO B store frequency, mode and filter choice independently. Here is a typical scenario and control sequence. You find a DX station that is listening "UP 5". Press SPLIT. Press A=B. Press and hold REV and tune opposite VFO up 5 KHz and release REV. You are ready to call the DX. Anytime you press and hold REV, you are listening to the transmit frequency. While holding REV you can tune the transmit frequency. When REV is released, the receive frequency is instantly restored. If you are using SPLIT mode and hear a simplex operation you want to call, just press A=B and call.

3-2.3 RIT OPERATION You can use either VFO and each has its own independent RIT value. Select frequency, mode and filter. Press RIT. Use RIT/XIT knob to change the receiver frequency. The offset system tuning range is +/- 9.99 KHz. When RIT is on, the transmit frequency is shown in the main display and the offset displayed should be added or subtracted to determine the receive frequency. The main display can be changed to include the RIT/XIT amount in the USER OPTIONS MENU, option OdP (offset display preference). Exercise caution if you select this display option as the actual TX frequency is not immediately obvious when viewing the displays.

There are two methods of quickly returning RIT to zero. Press RIT to turn it off. (The next time you turn RIT on, the same offset will return). The second method is: press RIT and hold for 1 second. This clears offset to zero and leaves RIT on. If you switch to the other VFO, all of the information, including RIT status, is stored.

3-2.4 XIT OPERATION This works the same as RIT except the main and offset displays are reversed. The receiver frequency is shown in the main display. Adding or subtracting the displayed offset value to the main frequency displayed equals the transmit frequency.

3-2.5 SIMULTANEOUS RIT/XIT OPERATION Both functions can be activated. When both are activated, you are operating simplex at the offset displayed. The RIT/XIT knob sets the transceiver frequency to the displayed offset, not the main frequency display. This seems redundant but there is a good application. For example, you are running your own pile-up in a contest using RIT. Another station calls CQ 1 KHz above your transmit frequency. Tune in the station, using RIT. Press XIT. You are now simplex on the interfering station. Ask him to QSY and press XIT off. Your station is now back at your original transmit frequency.

3-2.6 CROSS BAND OPERATION This is most commonly required on 10 meters. An example is listening below 28.5 MHz and transmitting above 28.5 MHz. Although transparent to the operator, each band position covers 500 KHz. These splits can be programmed but the receive/transmit switching time will be longer. You may wish to use PTT

(not VOX) on SSB and a manual transmit switch in the MUTE jack on rear panel for CW Operation.

3-2.7 CROSS MODE OPERATION

Whether operating on one band or cross band, cross mode is permitted. Put the receive setup in VFO A and the transmit setup in VFO B.

3-3.0 THE MEMORY SYSTEM There are three types of memories:

- One scratch pad memory
- Band register for each ham band
- 100 general purpose memories

Each will store mode, filter selection, split frequency information, RIT and XIT. Band register does not store split. Once a memory is stored, it may be recalled at any time. Memories may be used in one of four ways as described in detail in this section: MS (memory scroll), MT (memory tune), automatic memory tune, automatic band scan.

NOTE: ANY OF THESE MULTIPLE KEY COMMAND SEQUENCES CAN BE ABORTED BEFORE COMPLETION BY PRESSING THE CLEAR BUTTON.

3-3.1 USING SCRATCH PAD MEMORY First, make sure that MS and MT are both OFF. To store a displayed frequency in the scratch pad, Press **[VFO ► M]** and hold for one second. An audible beep will sound when the data is stored (if annunciator feature is activated). To recall this data, press **[M ► VFO]** and hold for one second. Scratch pad contents will return to the active VFO.

3-3.2 BAND REGISTERS There is one band register for each ham band. It provides a method of quickly switching between two frequencies on a band. Tune VFO to a desired frequency. Press band button. Tune VFO to a different frequency. Press band button again. The frequency changed back to the first one. Each time band button is pressed, the two frequencies will exchange.

3-3.3 MEMORY STORE Set transceiver to the desired frequency, mode and I-F filter to be stored. Split, RIT and XIT will also be stored if active. Quickly, press **[VFO ► M]**. The lower right hand display will change to " ". Using the numeric keypad, enter a channel number from 00 to 99. Press ENTER. If you do not wish to assign a channel number, when the " " prompt appears, simply press ENTER and the information will be stored in the next unused channel. In this case, the unused channel number automatically selected will be displayed for a few seconds to allow you to note that channel number, if desired. If all channels are in use, the " " display will remain. You can either enter a channel number to be replaced with the current data or abort by pressing CLEAR.

3-3.4 MEMORY RECALL BY CHANNEL NUMBER Press **[M ► VFO]**. The channel display prompt " " will appear. Enter the desired channel number, 00 to 99, using the numeric keys. Press ENTER. The data in that memory channel will transfer to the active VFO (s).

3-3.5 USING MEMORY SCROLL Press MS. Note indicator light is now on. Use the main tuning knob to scroll

through the memories. Each memory will be displayed but the receiver will remain as set before MS was pressed. To cancel memory scroll, press MS again. To enter a displayed memory into the transceiver while using memory scroll, press **[M ► VFO]**. The transceiver will become active using the recalled data.

3-3.6 USING MEMORY TUNE Press MT. Tune through memories with main tuning knob. The transceiver is active on each channel as it is displayed. To cancel memory tune, press MT again. To enter a displayed channel into the VFO(s) while using memory tune, press **[M ► VFO]**. You can switch back and forth between MS and MT at random.

3-3.7 AUTOMATIC MEMORY TUNE Press and hold MT for one second. Transceiver will scan through memory channels automatically. The UP/DOWN buttons are used to adjust the scan rate. To enter a displayed channel into the VFO(s), press **[M ► VFO]**. To temporarily stop scanning, press and hold MT. To cancel scanning, press clear.

3-3.8 AUTOMATIC BAND SCAN Allows transceiver to scan between two frequencies within a ham band. Upper and lower limits are set using band register as one limit and the displayed VFO frequency as the other. Press MS and hold for one second. Up/down buttons are used to adjust scan rate. To stop scanning at a desired frequency, enter that frequency into the VFO, press ENTER. To cancel scan and return to the previous frequencies in the VFO, press CLEAR. Scanning can be done in either direction, up or down in frequency. If higher limit is displayed when starting, scan will be down. If lower limit is displayed when starting, scan will be up.

3-3.9 LOCK Allows user to lock main or remote tuning encoder. Also allows access to User Options. See next section.

3-4 USER OPTIONS MENU Permits each operator to tailor the transceiver to match personal preferences. Thirteen features can be controlled. These are listed below in the sequence found in the menu.

- ID 10 minute ID timer
- LP CW DSP low pass filter
- hd Baud rate for PC interface
- CdE Enable/Disable Matrix Mode
- C-id Address ID for PC interface
- FEP Frequency entry priority
- ANC Audio annunciators
- CCD Continuous clock display
- LCO Linear control relay
- I code Iambic keyer, type A or B
- bCP Band change preference
- ODP Offset display preference
- SPd Tuning Knob Speed Preference*

To access the menu:

1. Press LOCK button and hold for one second. Main frequency display now shows the first menu item (ID).
2. Press ENTER to cycle through the 13 menu choices. Each time ENTER is pressed the next choice is displayed. If you mistakenly pass a desired item, you must cycle through all remaining choices to return again.
3. Use UP/DOWN buttons to change the status of a menu choice.
4. Press LOCK to exit menu and save choices.

Refer to Table 3-2 on following page for detailed description of each menu choice.

**NOTE: THIS FEATURE ADDED TO UNITS AFTER AUGUST 1993. FEATURE CAN BE ADDED TO EARLIER UNITS FOR A NOMINAL FEE - CONTACT FACTORY.*

TABLE 3-2 USER OPTIONS MENU

Option Name	Description	Selections*
Id	Alerts operator to identify the station every 10 minutes	ON, OFF
LP	DSP audio lowpass filter active only in CW mode	OFF , 600, 800, 1000, 1200 or 1400 Hz.
bd	Baud rate for serial port personal computer interface	1200 , 2400, 4800, 9600 or 19200 baud
CdE	Enable/Disable Matrix Mode (Refer to Chapter 5: specialized command modes)	ON , OFF
C-id	Address identifier for this transceiver when using PC interface	01 - 64 (04)
FEP	Frequency entry priority. Sets primary function of numeric keypad. If set HI, keypad takes direct frequency entry. If set LO, keypad is a band switch. In either case, pressing ENTER before keypad reverses keypad to opposite or secondary function	LO , HI
ANC	Audio annunciators indicate when keypad buttons are pushed. If set to ALL, some buttons provide CW character indicator, others single tone. If set to bp, all buttons are single tone. Feature may be turned off.	ALL , OFF, bp
CCd	Continuous clock display or on demand only. If set to OFF, press CLK to display the time momentarily.	ON , OFF
LCO	Linear control relay. Enables relay for control of external non-QSK linear amplifier.	ON , OFF
I code	Iambic keyer. selects Curtis type A or B keyer operation.	A , B
bCP	Band change preference. If set to Full, band changes return to last frequency used on that band. If set to Partial, band changes move to same relative position on band. Ex: 21040 to 14040 MHz.	F , P
OdP	Offset display preference. If set OFF, main display always shows TX frequency regardless of RIT/XIT status. If set ON, main display follows RIT/XIT.	OFF, ON
SPd	Tuning Knob speed. 6 rates available.	.85 KHz per 1.02 2.56 tuning knob 1.28 5.12 resolution 1.71

3-5.0 OTHER FRONT PANEL CONTROLS (Refer to Figure 3-1).

3-5.01 RF OUTPUT POWER (PWR)

Set METER to FWD (forward power) and turn this control clockwise for the desired power level, up to 100 watts output. NOTE: If full clockwise does not result in 100 watts output, switch the meter to Ic collector current position and adjust the PWR control for an Ic not to exceed 20 amps. Read 3-5.02 below for more information on SWR.

3-5.02 FORWARD AND REFLECTED POWER

Anytime 100 watts output is not available, the most likely cause is SWR in the 2:1 range or higher. The transmitter is protected under this condition by a current limit that will not permit it to draw more than 22 amps. The SWR (reflected power) position on the meter reads SWR directly, on the bottom scale. In case of high SWR, the cause should be corrected or an antenna tuner should be used.

3-5.03 MIC GAIN ADJUSTMENT

With PTT or VOX activated, speak into your microphone at normal operating voice level and adjust MIC gain control so the ALC light just blinks on voice peaks.

3-5.04 SPEECH PROCESSOR USE

Press PROC (processor) switch ON. Switch METER to PROC. Adjust PROCESSOR control until voice peaks are in the heavy black line range just beyond half scale on the bottom PROC scale. Now, check the MIC gain setting and readjust, as needed, for ALC light blinks on voice peaks. When adjustments are complete, switch METER back to one of the other three positions. S-meter accu-

racy is affected when METER is in PROC position.

3-5.05 -20 dB RECEIVER ATTENUATOR

Because of the outstanding selectivity and usable dynamic range of this receiver, you may never need the ATTN feature. Should you experience receiver overload, turn the ATTN on.

3-5.06 NOISE BLANKER

This noise blanker is designed for pulse noise such as engine ignition, many common types of power line noise and noise from some common household appliances. When such noise is present, simply adjust the N.B. control for minimum interference. Always leave the N.B. control in the maximum counter clockwise position when not in use. This position is off.

NOTE: Voice peaks on a strong SSB signal look like noise pulses to the noise blanker. These peaks will be blanked if the N.B. control is not in the full CCW position and the received signal audio may sound badly distorted.

3-5.07 AUTOMATIC GAIN CONTROL (AGC) ON/OFF

The function of AGC is to maintain a relatively constant audio level over a wide range of received signal strengths. Some operators will argue that under extreme weak signal conditions better intelligibility is delivered with the AGC off, the AF gain full clockwise and using the RF gain control for a volume control. Use caution when using this setup, keep one hand on the RF gain control. If a strong signal appears nearby, it will be very loud. The more commonly used setup is with AGC on, RF gain full clockwise and using AF gain for the volume control. If AGC is off, "S" meter is not active.

3-5.08 AUTOMATIC GAIN CONTROL, FAST/SLOW This switch selects the attack and decay speeds of the AGC circuit. As a general rule, use FAST AGC on key-down modes such as RTTY, and FM, weak SSB and CW signals. Use SLOW AGC on strong SSB and CW signals. This will minimize the noise level received between voice peaks and CW characters.

3-5.09 AUDIO (AF) AND RF GAIN CONTROLS As a general rule, the RF gain control will always be set at maximum clockwise and use the AF control for audio volume level adjustments. See 3-5.07 AGC ON/OFF above, for alternate methods.

3-5.10 S-METER Any time the transceiver is in receive mode and the RF gain control at the maximum clockwise position, the S-meter is functional, regardless of the METER switch position. Each S-unit is 6 dB. S9 is calibrated at 50 μ V.

3-5.11 SQUELCH This control is in the circuit in the FM mode only. Select FM mode, tune to a clear frequency and adjust the squelch control just into the threshold for receiver quieting.

NOTE: FM operation on the HF bands is presently authorized from 29.0 to 29.7 MHz only

3-5.12 PASS BAND TUNING (PBT) This is one of the most useful of all of the receiver controls. It allows you to move the pass band back and forth across the desired signal. It can be used to "drop" QRM out of one side or the other of the pass band or it can simply be used to improve the quality and intelligibility

of a signal. The typical operating position of the control on SSB and CW is between 10:00 and 2:00. This will vary depending on which I-F filter is selected. When operating any of the digital modes, such as RTTY, AMTOR or PACKET, the control position will center at about 3:00. Use PBT to balance the amplitude of the mark and space signals and to deal with QRM.

3-5.13 USING THE NOTCH SYSTEM The function of this unique DSP, Digital Signal Processing, system is to eliminate "carrier" interference. It is essential that you understand both the MANUAL and AUTOMATIC MODES. They can be used separately or simultaneously.

- a. **AUTOMATIC MODE:** This is used on the voice modes only. The manual notch control has no effect, on the AUTO notch, except the high frequency audio hiss can be reduced. When AUTO is selected, any carrier or multiple carriers will be automatically notched out. If you attempt to use AUTO on CW or digital modes, the desired signal will also be notched out.
- b. **MANUAL MODE:** Use for CW and the digital modes (always available). When the NOTCH control is full counter clockwise, NOTCH is out of the circuit. Adjust the Notch control clockwise to eliminate interfering carrier type signal.

3-5.14 QSK FAST/SLOW This selects the speed with which the transceiver switches between transmit and receive. QSK FAST is normally used for full break-in CW and for operation on AMTOR using the FSK mode. QSK

SLOW is primarily for CW operators that do not prefer high speed, full break-in operation. The delay time in QSK SLOW is programmable. To adjust: Place transceiver in CW mode. Press DLY (delay) button. Use UP/DOWN buttons to select setting from 01-15. This setting is independent from your DLY setting when in SSB mode for VOX DLY. Press ENTER to save. When QSK SLOW is selected and linear relay is turned on in the USER OPTIONS MENU, this programmed delay is also the relay hang time. QSK can be overridden entirely by plugging a hand or foot operated transmit/receive switch into the rear panel MUTE jack.

3-5.15 ANTENNA SWITCH, MAIN/AUXILIARY If a traditional transceive antenna is connected through the SO-239 coax connector on the rear panel, select MAIN antenna. If a separate receive antenna is connected through the rear panel AUX RX ANTENNA phono jack, select AUX. Both antennas may remain connected to the transceiver. They are switched internally for proper isolation.

3-6 REAR PANEL CONNECTIONS (Refer to Figure 3-2)

3-6.01 EXTERNAL SPEAKER This 1/4" jack supplies audio to an external 4-16 ohm speaker. The level is controlled by front panel AF control. Built-in speaker is muted when this jack is used.

3-6.02 INTERFACE PORT This 25 pin "D" connector allows direct RS-232 interface with a personal computer. See Chapter 5 for pin assignments. This port is also used to interface with TEN-TEC accessories such as Model 301 Remote Frequency Tuning Control, Model 253

Automatic Antenna Coupler and Model 420 Solid State Linear Amplifier. Accessory "Y" and extension cables are available. Pins 2&3 are reversed as compared to OMNI V. Use standard serial cable to connect to computer.

3-6.03 MARK/SPACE Controls the FSK circuit on the digital modes and is typically connected to FSK output jack of a modem or terminal unit. Logic levels required are less than or equal to 1.0 Vdc for MARK, equal to or greater than 2.0 Vdc for SPACE. Either a standard TTL level or open collector output will drive it.

3-6.04 AUDIO IN This input is in parallel with the front panel MIC connector. Input level is adjustable by front panel MIC gain control.

3-6.05 AUDIO OUT Fixed level audio out, 1 mw @ 600 ohms, intended for accessories such as phone patch or digital mode equipment.

3-6.06 SERIAL PORT This 1/8" jack allows 2 wire computer control through a serial level converter such as TEN-TEC Model 305.

3-6.07 POWER A four pin connector is the input for primary dc power. See Chapter 1, Section 1-1 for wiring information.

3-6.08 GND Ground post to be attached to the station ground.

3-6.09 TX OUT/TX EN Amplifier control lines for use with TEN-TEC QSK linears. Must be jumpered when not connected through a TEN-TEC amplifier or unit will not transmit.

3-6.10 MUTE Input for manual transmit/receive switching such as a hand or foot switch used to over-ride QSK on CW mode.

3-6.11 PTT Use for transmitter control on any mode other than CW. This is in parallel with the PTT connections on front panel MIC connector. Generally used for external systems such as digital gear.

3-6.12 KEY Connection for an independent, external, CW key or keyer.

3-6.13 KEYER To connect external paddles to operate built-in electronic keyer. See Chapter 1, Section 1-4 for wiring information.

3-6.14 AUX +13.5 V Any accessory that operates at 13.5 Vdc, less than 2 amps, can be powered from this jack. Turn power off before connecting to or disconnecting from this jack.

3-6.15 RELAY [N.O.] Used to control non-QSK amplifier requiring heavy relay switching capacity. Delay is adjustable in QSK SLOW. See Section 3-5.14. To enable this relay which is normally turned off, see Section 3-4.17, USER OPTIONS MENU (LOC).

3-6.16 AUX RX ANTENNA Input for separate receive antenna. Selected by front panel antenna switch, AUX position. Antenna may remain connected whether or not it is in use.

3-6.17 50 OHM ANTENNA Connection to the transmitter output and antenna input to the receiver when a single antenna is used for transceive.

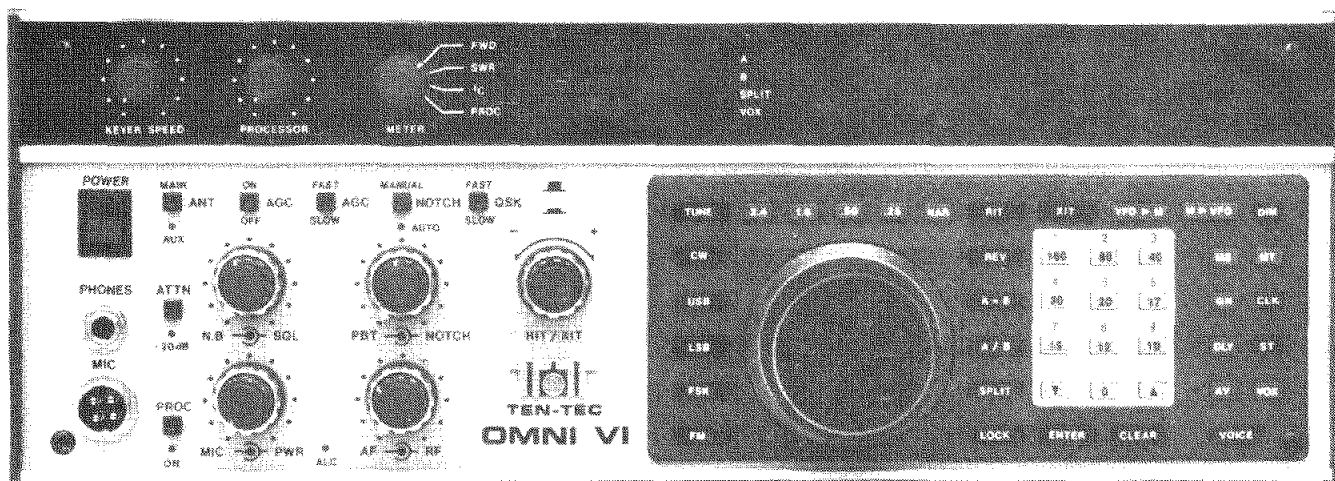

FIGURE 3-1. MODEL 563 FRONT VIEW

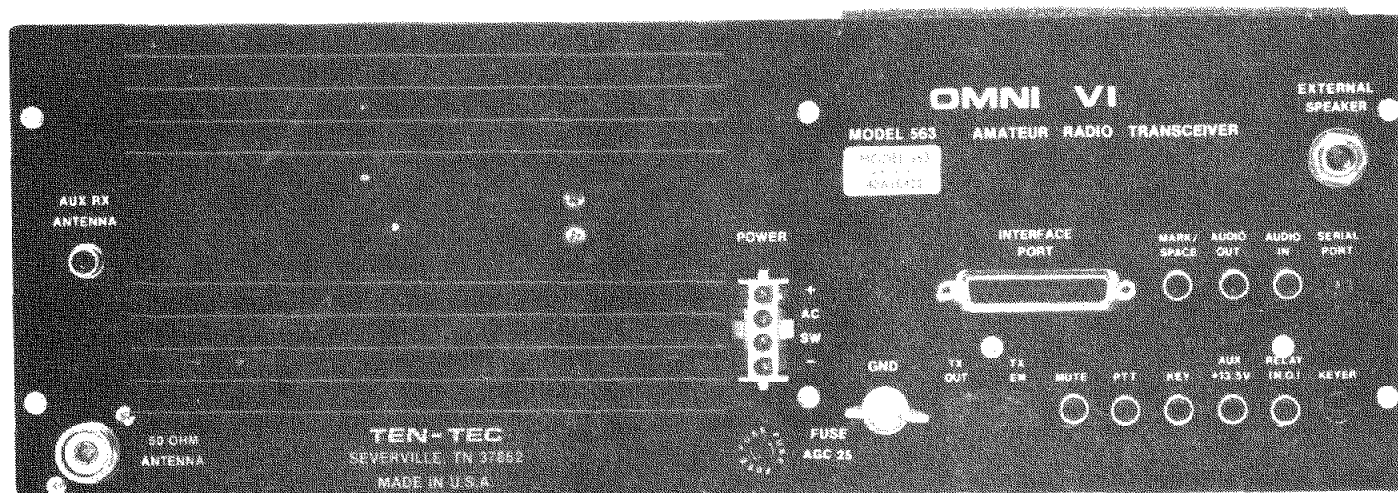

FIGURE 3-2. MODEL 563 REAR VIEW

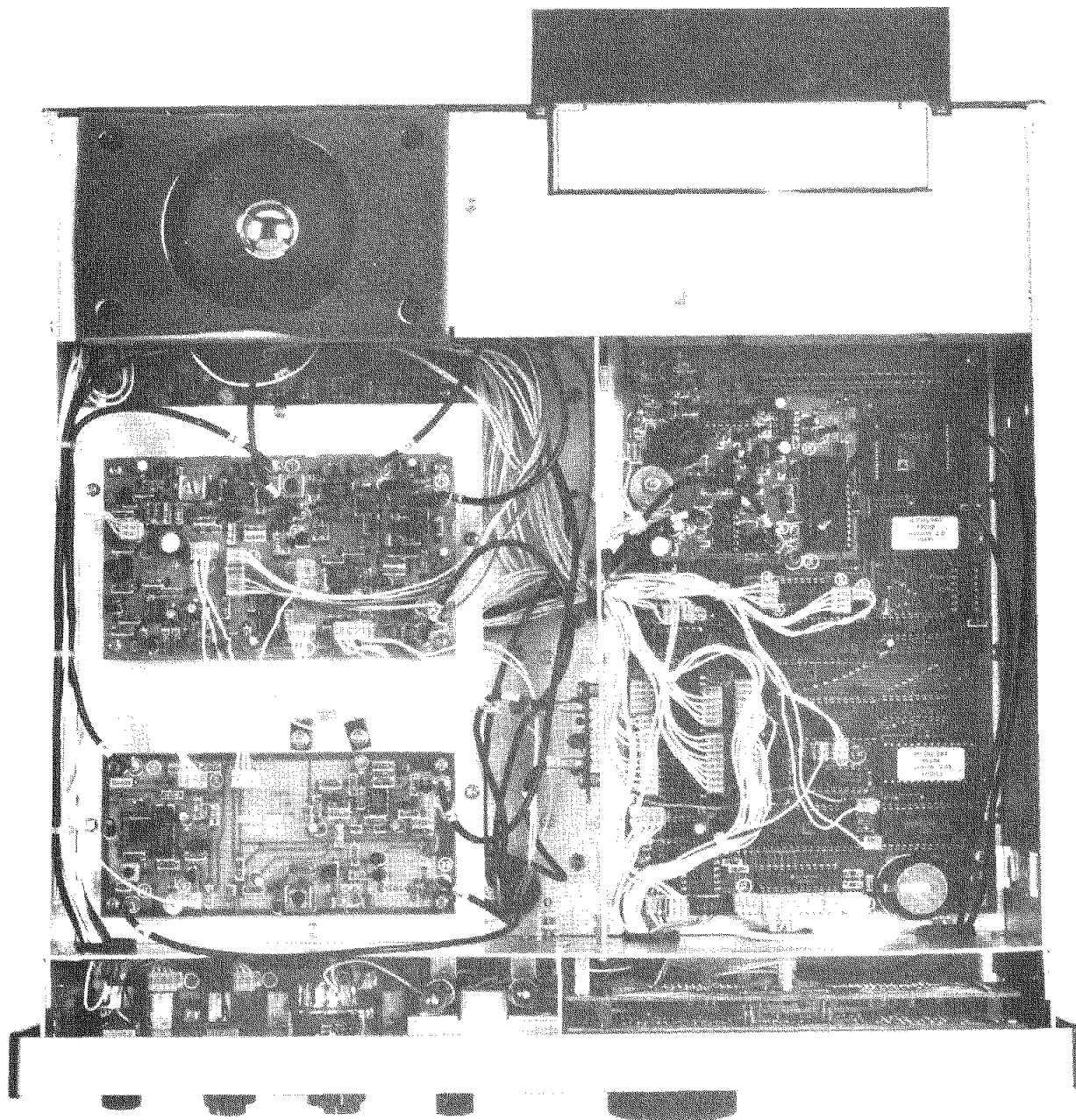

FIGURE 3-3. MODEL 563 TOP VIEW

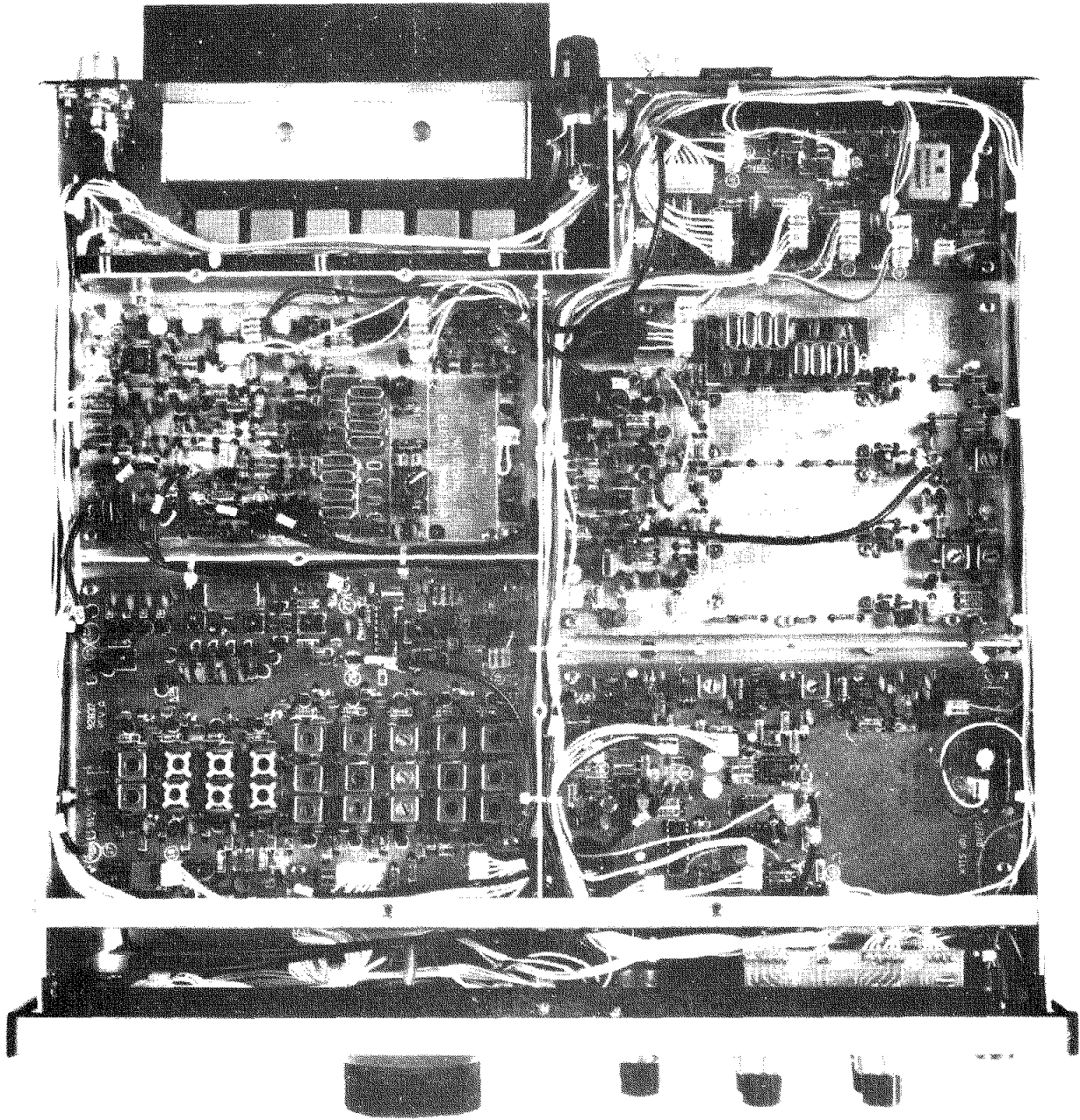

FIGURE 3-4. MODEL 563 BOTTOM VIEW

CHAPTER 4

CIRCUIT DESCRIPTIONS AND ILLUSTRATIONS

4-1 INTRODUCTION The Model 563 OMNI VI combines the low phase noise characteristics of crystal oscillators with the programmability and precision of a 5.0 to 5.5 MHz PLL synthesizer system. The following sections contain detailed circuit descriptions for all of the printed circuit board modules used in the OMNI VI. Also included are pictures of the modules with selected components identified. These drawings are followed by schematic diagrams for each circuit board module.

4-2 DC POWER INPUT BOARD (81591)

This module is located inside the low pass filter cage at the back of the transceiver. On the rear panel, the DC Power connector brings in +13.5 VDC through fuse F1. Only a fast blow style AGC25 should be used here.

On the DC Power Input board, Q2 controls the power-on relay K1. Q2 is biased on through the front panel POWER switch at connector 1. Over voltage protection is provided by D1 and Q1. If the DC voltage exceeds 16 volts, SCR Q1 will trigger and keep Q2 from closing the relay. Resistor R5 samples the current delivered to the 100W RF amplifier module. This small voltage drop is cabled through connector 5 to the 9 MHz Filter / ALC board where it is monitored by the ALC circuitry. Connectors 2, 3 and 4 distribute +13.5 VDC out to other boards.

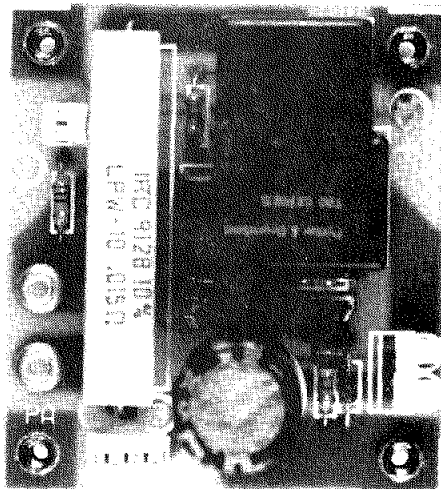

FIGURE 4-1. DC INPUT BOARD COMPONENT LAYOUT (81591)

4-3 LOW PASS FILTER BOARD (81592)

This module contains an array of six 5-pole low pass output filters, the T/R switching circuitry, directional coupler for forward power and SWR detection, and diode switched receive antenna circuits.

Six band lines from the BPF/Front End board enter at connector 14 where they pass through rf chokes L6 - L11 and energize relays K2 - K13. These band lines also exit at connector 8, where they are routed through the TX Audio board to the 25-pin connector on the rear panel of the OMNI VI. Only one of the six lines is high at any one time based on the operating frequency of the transceiver.

The 100 Watt RF output of the PA passes through one of the selected low pass filters and then through the contacts of relay K1, which is energized by "T" voltage. The output power then proceeds through the primary of the SWR bridge transformer T1 to the rear panel antenna connector. Bridge transformer T1 and associated circuitry discriminate between forward and reflected power to develop drive voltages at connector 12 for the ALC and RF metering circuits on the 9 MHz Mixer/IF board.

On receive, K1 is open and "R" voltage is either applied to R24 or R25 through connector 7. The front panel mounted ANTenna switch selects R24 for the main receive antenna and R25 for the AUX receive antenna at connector 13. When the Main Antenna is selected, "R" voltage is applied through R24 to the emitter of Q1. This turns on Q1 and forward bias diodes D4 and D5 thus allowing the signals from the Main Antenna connector to pass through to the receiver front end at connector 17. With Aux. Antenna selected, "R" voltage is passed through R25 to turn on diodes D2 and D3 allowing the Aux. Receive Antenna signals to pass through to the receiver front end.

During transmit relay K1 is closed and passes the filtered PA output to the Main

Antenna connector. A small sample of the transmit signal is passed through C12 to voltage doubler D8 - D11, which develops about 150 volts of reverse bias for diode switch D5 and D4, to protect these diodes and prevent the transmitter signal from leaking into the receiver front end.

Connector 9 brings "T" and "R" voltages from the Control board to the circuits on the Low Pass Filter module.

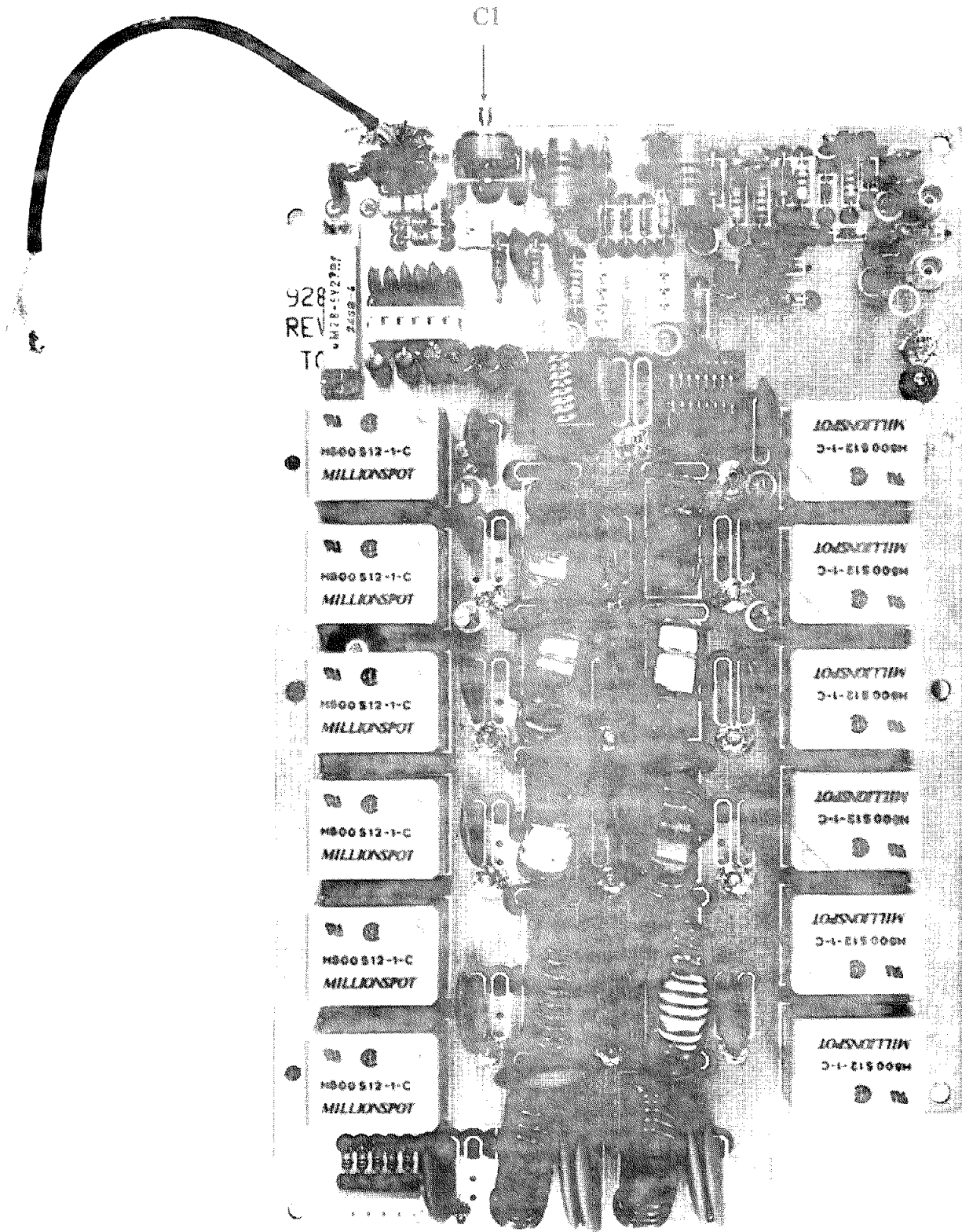
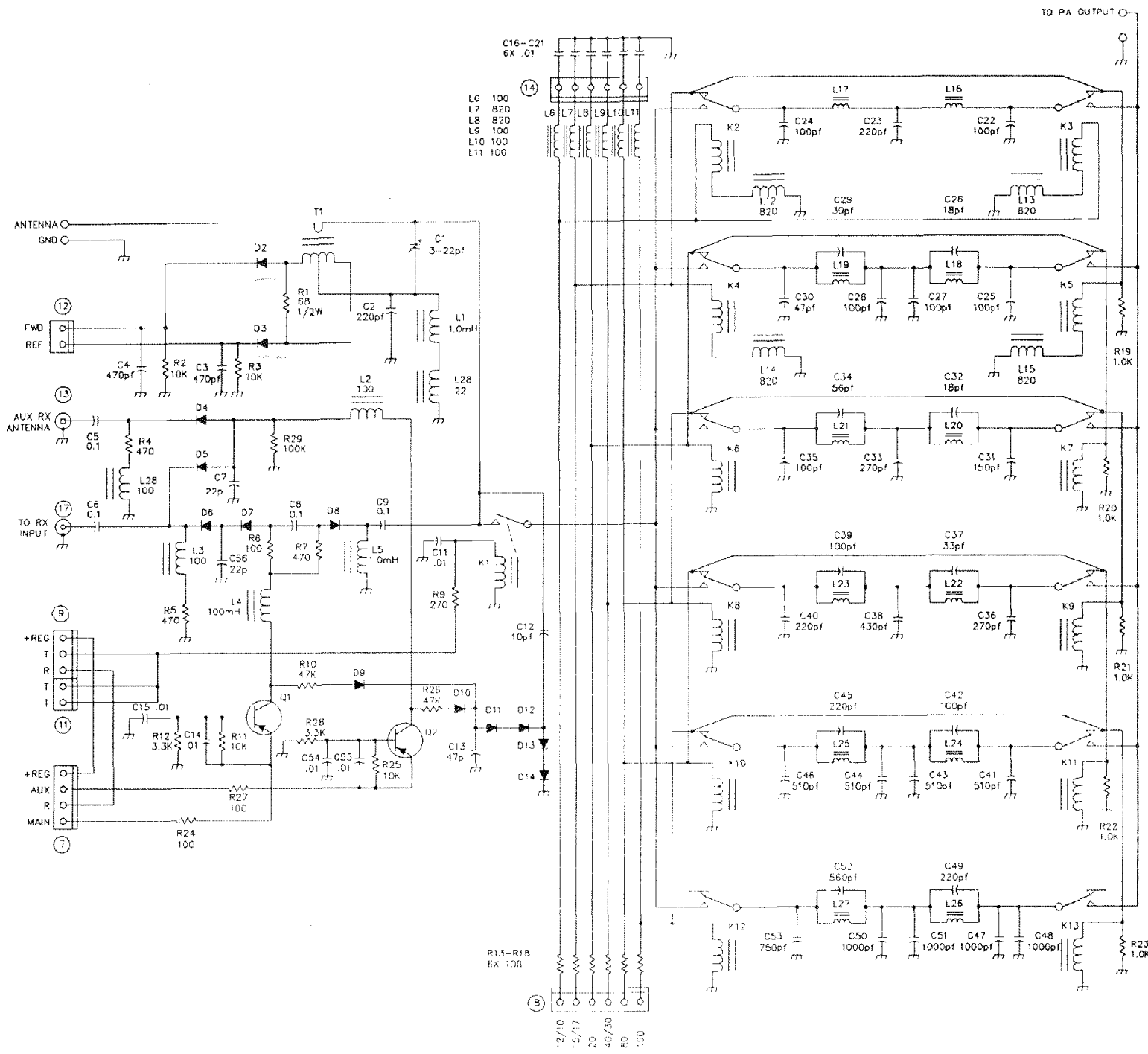

FIGURE 4-3. LOW PASS FILTER BOARD COMPONENT LAYOUT (81592)



C16-C21
6X .01

L6	100
L7	820
L8	820
L9	100
L10	100
L11	100

REFERENCE DESIGNATORS LAST USED:
C54, D17, K13, L28, Q2, R29, T1

NOTE: UNLESS OTHERWISE SPECIFIED
1) CAPACITORS IN MICROFARADS (uF)
2) INDUCTORS IN MICROHENRYS (uH)
3) RESISTORS IN OHMS ±5% 1/4W

D1	8A482
Q2-D3	8AT41
D4-D5	MPN1700
D6-D8	1N4007
D9-D14	1N4148
Q1-Q2	2N6519

L16	85332-15	32 uH
L17	85332-14	32 uH
L18	85332-12	43 uH
L19	85332-13	40 uH
L20	85332-10	58 uH
L21	85332-11	43 uH
L22	85332-08	81 uH
L23	85332-09	65 uH
L24	85332-03	2.3 uH
L25	85332-04	1.8 uH
L26	85332-05	3.4 uH
L27	85332-02	7.5 uH

FIGURE 4-4. LOW PASS FILTER BOARD SCHEMATIC (81592)

4-4 BPF / FRONT END BOARD (81593)

This module handles the receive functions of band pass filtering, RF preamplifier, receive mixer and mixer post amplifier. Transmit functions include transmit mixer, transmit amplifier and band pass filtering.

On receive the incoming signals enter at connector 17. Relay K1, R10 and R11 make up the switchable -20 dB attenuator network controlled from the front panel. Following the attenuator is an AM broadcast high pass filter which cuts out everything below about 1.6 MHz. This protects the filter switching diodes from large AM broadcast signals. Transformer T8 and capacitor C4, create a tuneable notch filter which is set to the receiver's IF frequency of 9 MHz. This network helps improve the IF rejection of the receiver, especially on the 40 meter and 30 meter bands where the desired signals are close in frequency to the 9 MHz IF.

Top coupled band pass filters, one for each ham band, are selected from connector 86. These filters protect the front end from unne-

cessary out of band signals and set the IF and image rejection performance of the receiver.

The grounded gate amplifier stage, Q2-Q5, provides about 9 dB of gain at a very low noise figure. It's output feeds the high level diode mixer D31. LO drive to the mixer is amplified by Q10 and Q11. The mixer output is terminated through matching transformer T6 into another grounded gate stage Q6-Q9. This post amplifier is set for about 6 dB gain and drives the 9 MHz two-pole monolithic filter on the 9 MHz crystal filter board through connector 25.

On transmit the active mixer circuit, U1, translates the transmit IF signal from connector 27 to the desired operating frequency. The mixer output is amplified by Q1 and applied to the band pass filters which remove unwanted mixer components from the transmit carrier. Once filtered, the transmit signal is routed from connector 24 to the Low Level Driver board.

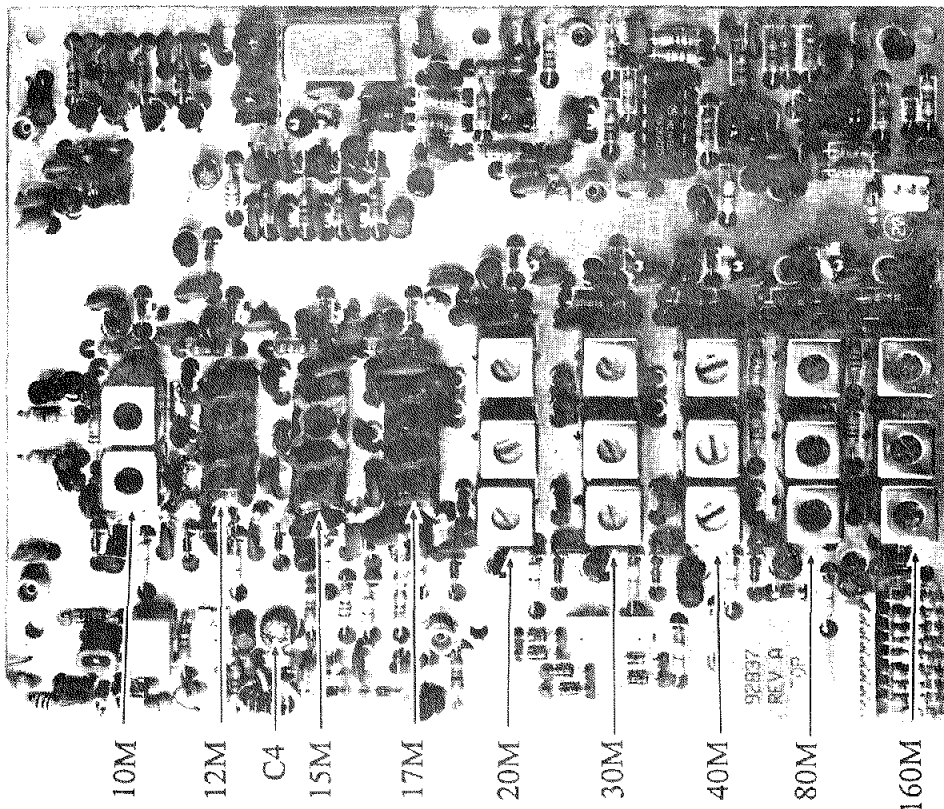
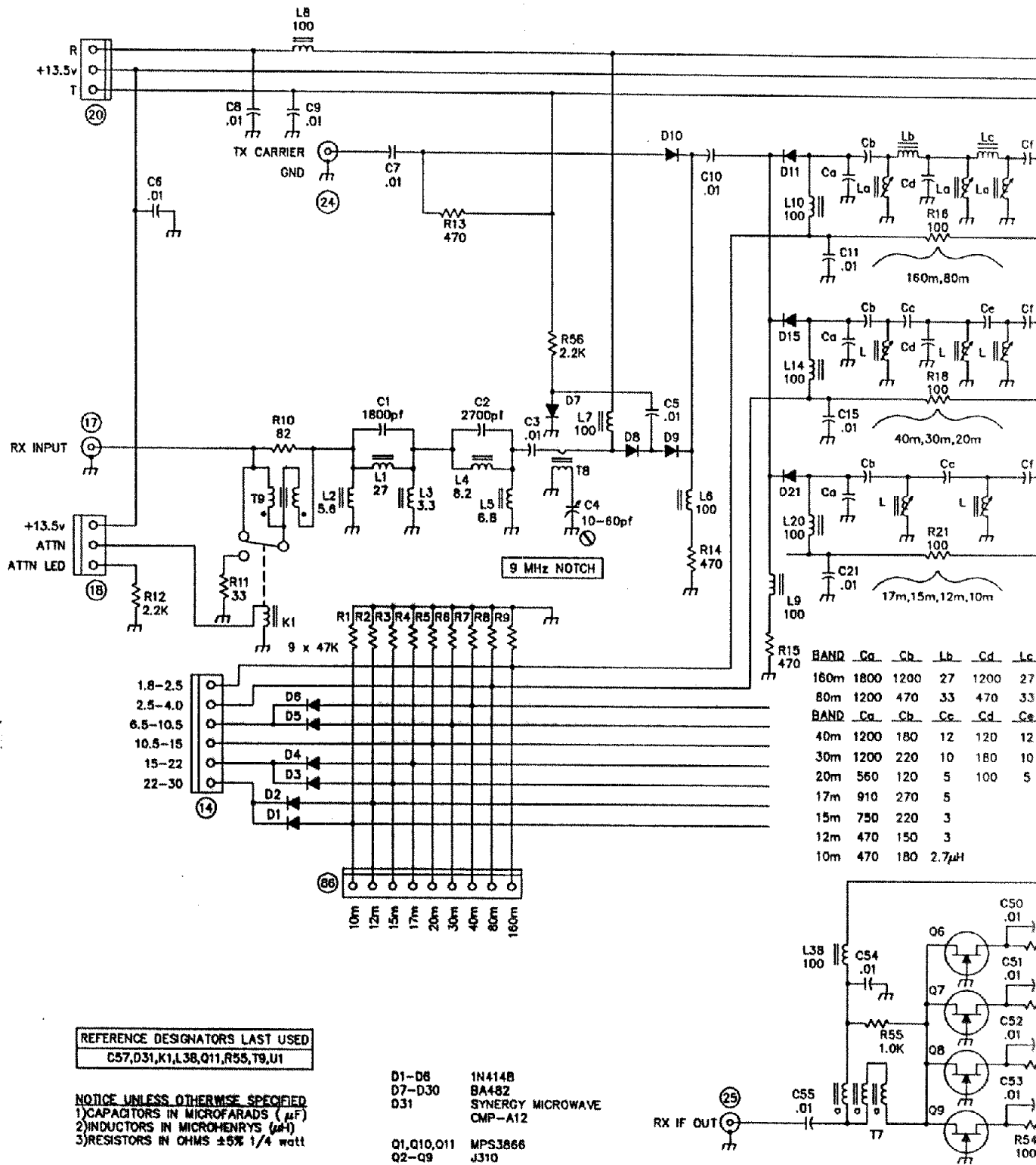

FIGURE 4-5. BPF / FRONT END BOARD COMPONENT LAYOUT (81593)



REFERENCE DESIGNATORS LAST USED
C57,D31,K1,L38,Q11,R55,T9,U1

NOTICE UNLESS OTHERWISE SPECIFIED
1) CAPACITORS IN MICROFARADS (μ F)
2) INDUCTORS IN MICROMHENRYS (μ H)
3) RESISTORS IN OHMS \pm 5% 1/4 watt

D1-D6 1N4148
D7-D30 BA482
D31 SYNERGY MICROWAVE
CMP-A12
Q1,Q10,Q11 MPS3866
Q2-Q9 J310

FIGURE 4-6. BPF / FRONT END BOARD

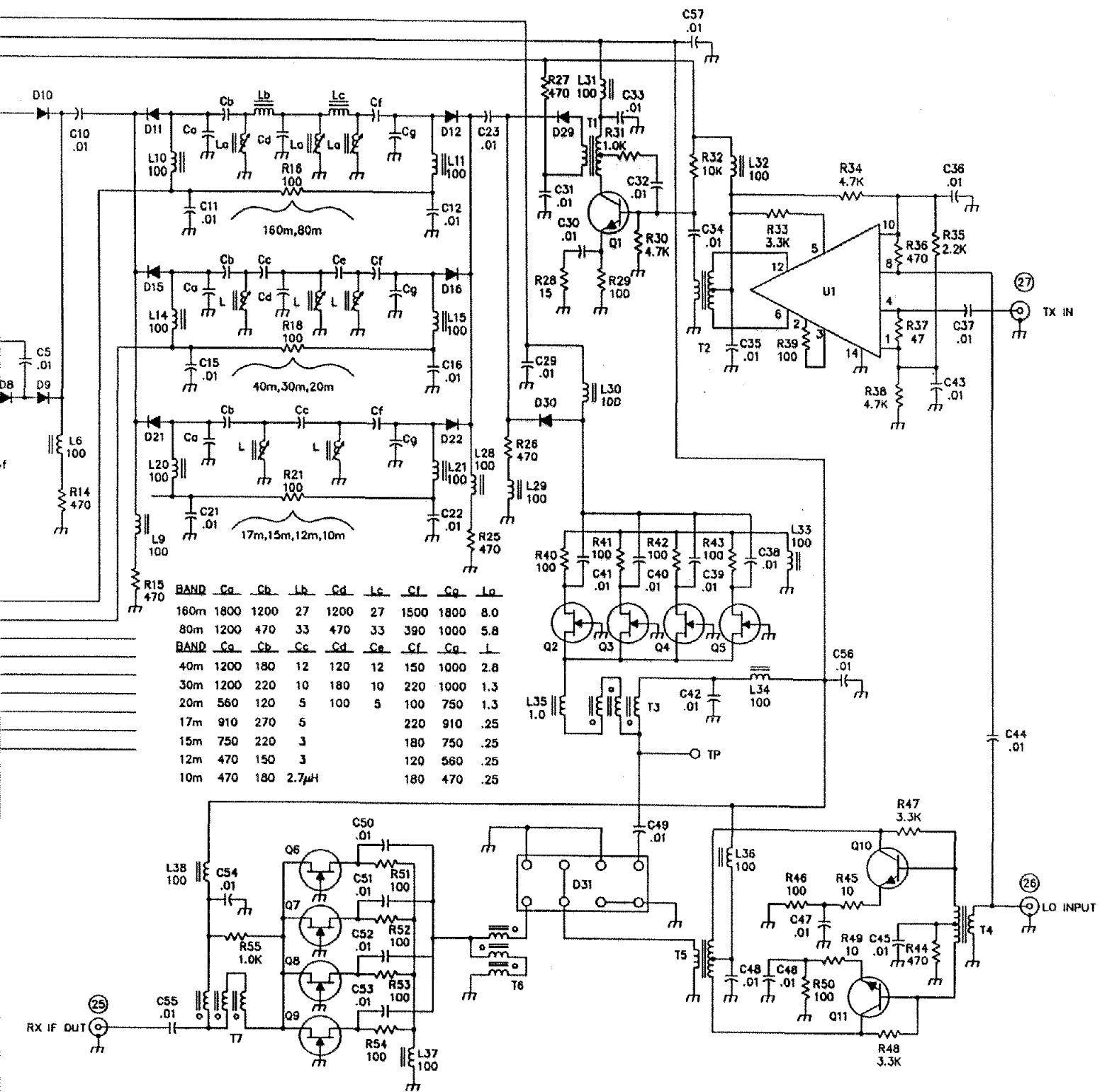

FIG 4-6. BPF / FRONT END BOARD SCHEMATIC (81593)

4-5 9 MHZ MIXER / IF BOARD (81594)

The 9 MHz Mixer / IF module integrates several transmit and receive functions. On receive this board performs the first narrow filtering for both FM and SSB/CW. Noise blanker sampling and noise gate circuitry are also included. On transmit the automatic level control and all the metering circuitry is included.

Receive signals from the Front End / 1st Mixer enter at connector 25. Two tuneable pi networks match a 2 pole monolithic filter, Y1, into the 50 ohm system. This 15 kHz bandwidth filter protects circuits further down from strong out of band signals. This is especially important to the operation of the noise blanker and FM detector.

The band limited signals are amplified by Q1, which drives buffer stage Q2 and the LC bandpass filter of T2, T3 and C10 - C12. This filter adds the slight amount of group delay needed to get the noise blanker's output pulse ahead of the offending noise pulse. The noise gate T4, T5 and diodes D1 - D4, can then open in time to prevent noise spikes from reaching the narrow filter Y2. This eight pole 2.4 kHz ladder filter is the first stage of SSB/CW selectivity. An additional filter position can be selected with the front panel NAR button. This optional filter is positioned in series with the standard filter so that the two responses add. Another low noise amplifier stage, Q4, between the two filters preserves the receiver noise figure and can be set to compensate for the loss of several different filters.

On transmit, single sideband generation is accomplished by using the standard 9 MHz filter to strip off one half of the double sideband signal at connector 37. This SSB signal is then amplified by Q7 and Q8. A voltage controlled attenuator, constructed from pin diodes D18 and D19, regulates the level of the transmit carrier at the output connector 27.

The control voltage for the attenuator is

derived from the forward power voltage at connector 12. This arrangement provides negative feedback to hold the peak transmit output power constant under changing amounts of microphone drive. A separate circuit with U2 and Q14 monitors the Final Amplifier current consumption. The transmit carrier is cut back if the current drain exceeds a safe level. This feature gives the amplifier some tolerance to badly matched loads.

Alignment

In the receive path there are four tuned circuits to peak. C3 and C4 optimize the matching of monolithic filter Y1. C10 and C12 resonate the LC bandpass filter. These adjustments should be made using a signal generator and an audio level meter. Tune in the test signal and adjust each trimmer for peak output.

The transmitter alignment requires a 50 ohm dummy load, an accurate rf watt meter and a DC ammeter with 20 to 30 amperes full scale. Hook the ammeter in series with the DC supply to the transceiver. Using the 20M band, key the transceiver through the watt meter and into the dummy load. With the front panel RF PWR knob completely clockwise, adjust R46 for 100 watts. Set the Meter Switch to FWD and adjust R52 for a 100W indication. Set the meter switch to Ic and note the reading on the DC ammeter. Adjust R57 until the panel meter indicates 2 amperes less than the DC current measurement.

To set the current limiting, first turn back the RF PWR knob to about the 12 o'clock position. Now unplug cable #12. Slowly advance the RF PWR control while watching the DC ammeter. Adjust R54 so that the transceiver draws 22 amperes with the RF PWR control turned fully clockwise. Reconnect cable #12 and check that the output power returns to about 100 watts.

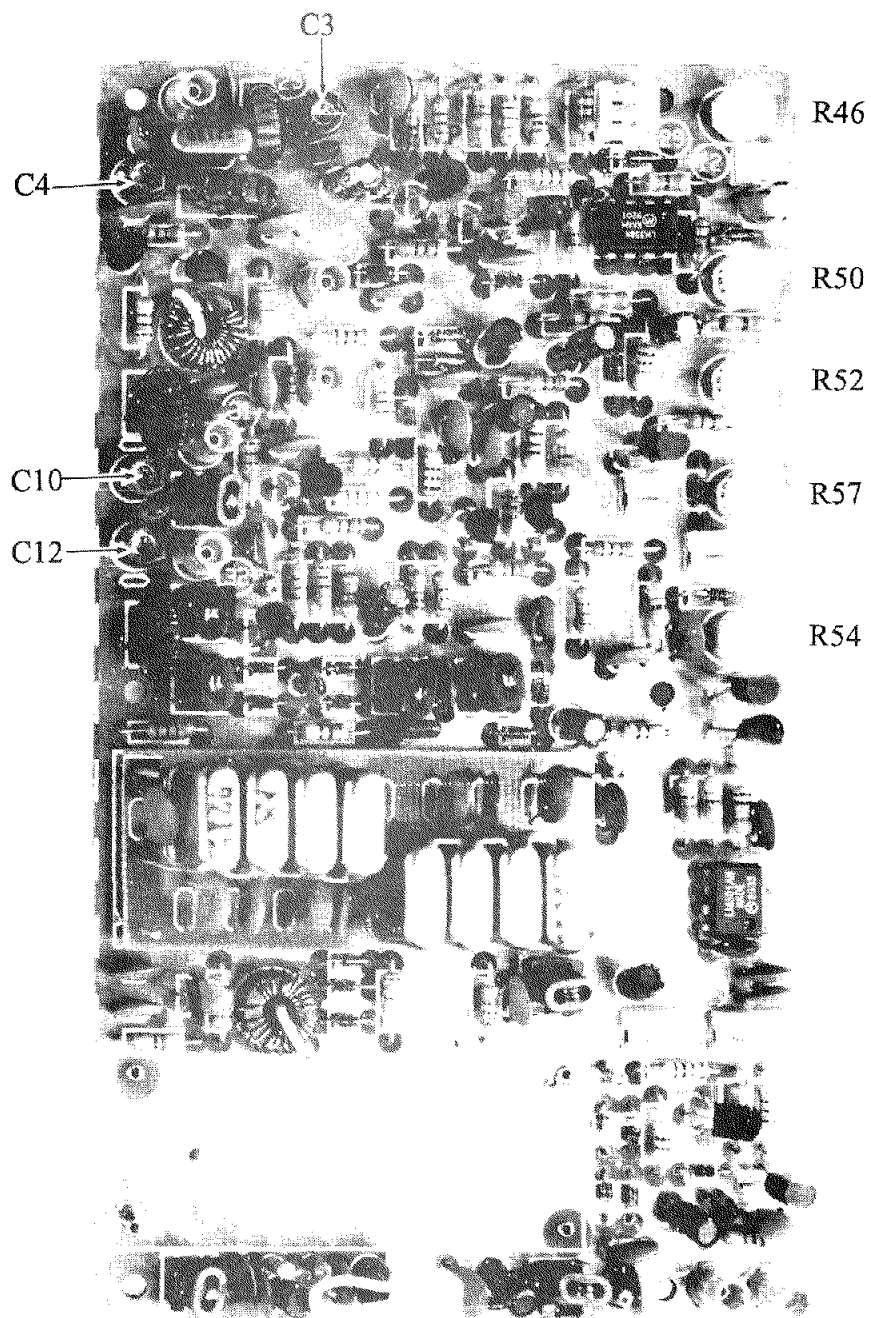

FIGURE 4-7. 9 MHz MIXER / IF BOARD COMPONENT LAYOUT (81594)

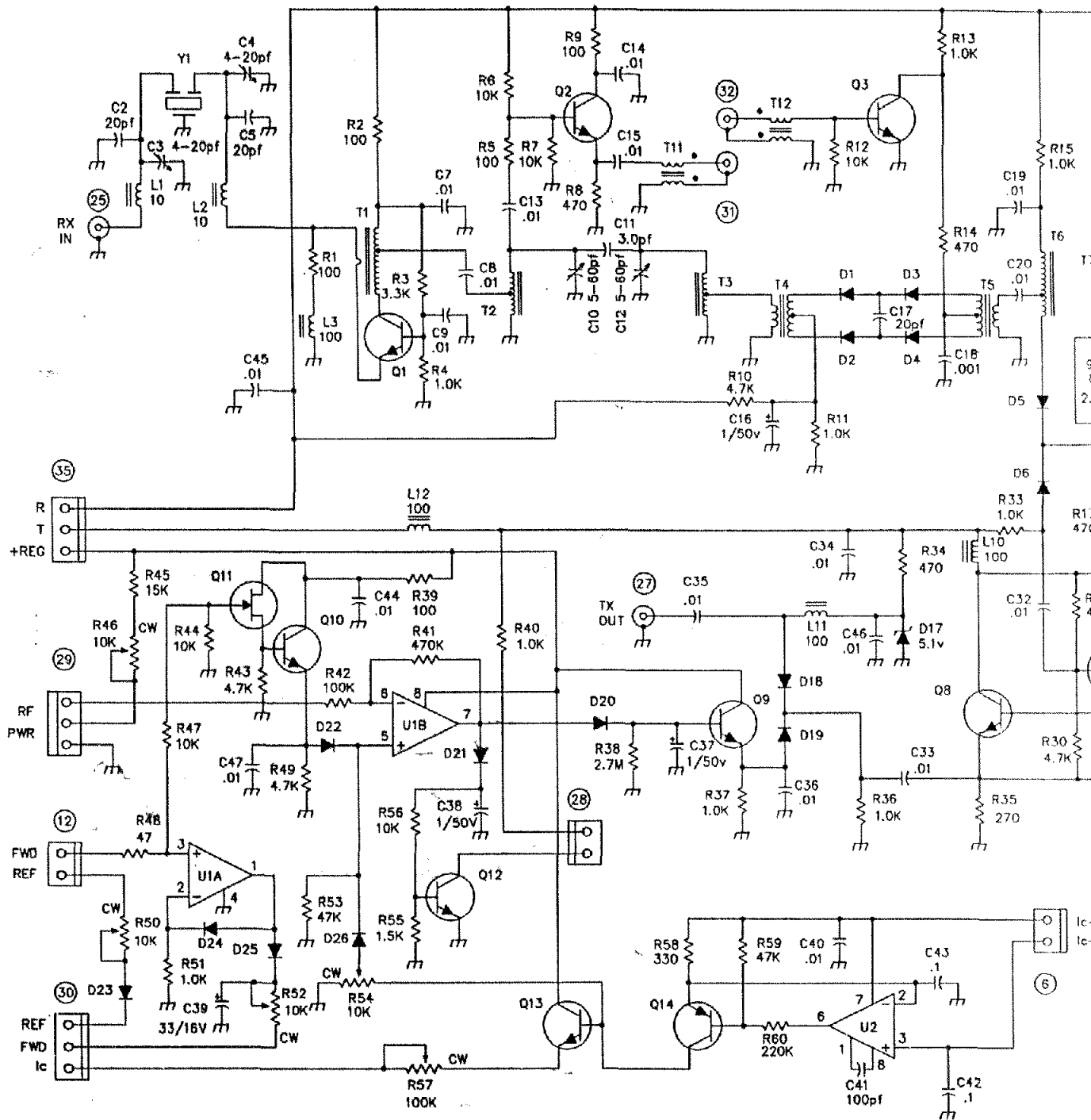
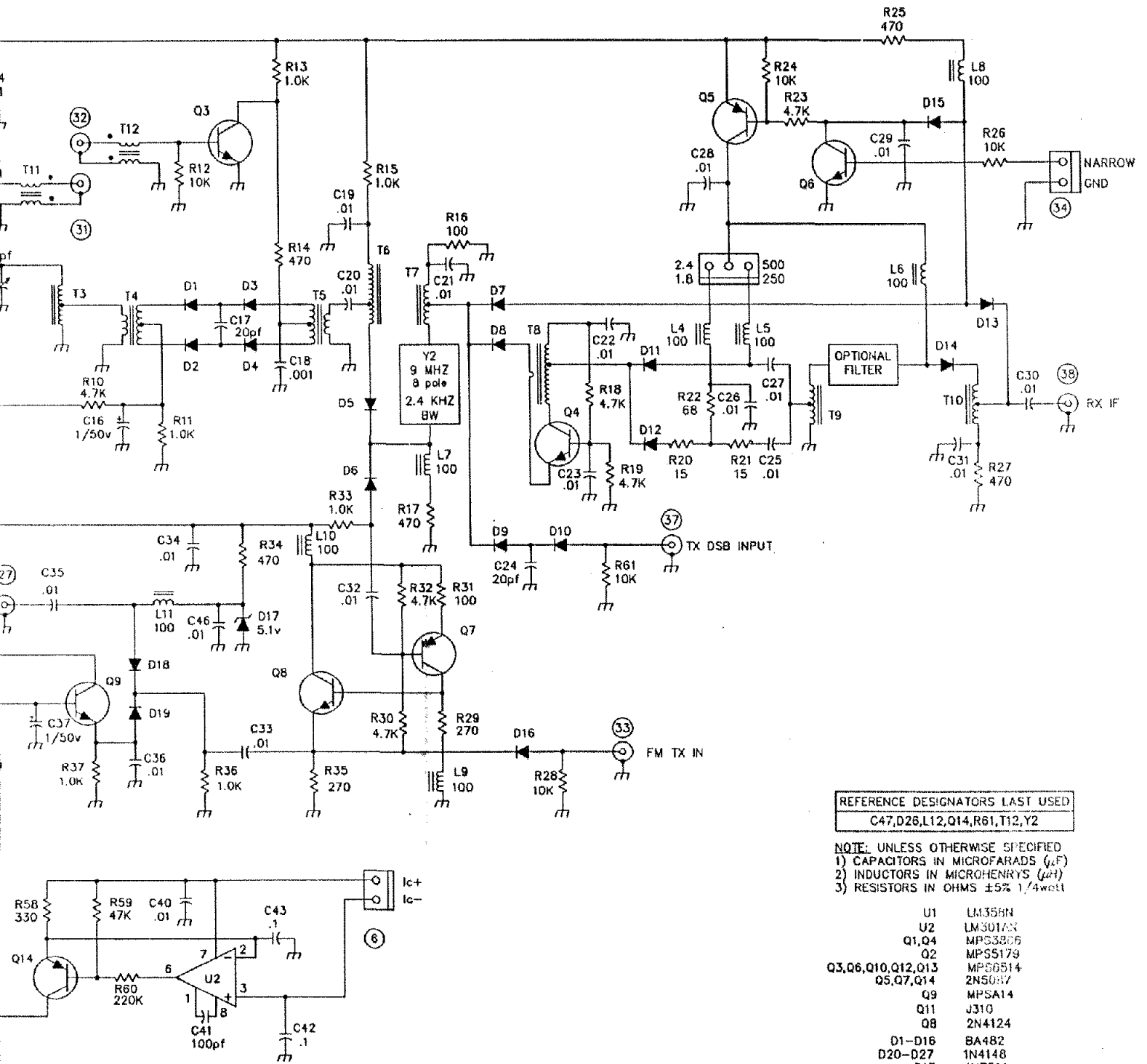

FIGURE 4-8. 9 MHz MIXER / IF BOARD

Part No. 74229
4th Printing 2/94
Printed in U.S.A.



4-8. 9 MHz MIXER / IF BOARD SCHEMATIC (81594)

4-6 PASS BAND TUNING BOARD (81600)

The Pass Band Tuning module enables the operator to position a crystal filter passband relative to incoming receive signals. By adjusting the front panel PBT control, the receiver bandwidth can be manipulated to reject interference. The standard 2.4 kHz 8 pole or one of three optional filters can be selected with the Bandwidth buttons above the main tuning knob.

Noiseless feedback amplifier Q1 takes receive signals from the 9 MHz filter board at connector 38. This stage feeds the diode ring mixer D1 - D4. L.O. for the mixer comes from the 15.3 MHz voltage controlled crystal oscillator Q4. The mixer translates the 9 MHz input signal down to the 6.3 MHz passband of the crystal filters. The exact position of the receive signals relative to the crystal filter is set by the voltage on varactor D5. Two alignment steps set the tuning range to ± 2.0 kHz.

One of four filters is selected by the Logic board through connector 41. Each filter is

preceded by a resistor pad to equalize the signal loss regardless of bandwidth and three pin diodes at each position help maintain the 90 dB ultimate rejection. Following the filters is the second mixer stage Q9. The dual gate MOSFET translates the receive signals back up to 9 MHz for the IF/AF board. Three tuned circuits with L17, L19 and L21 peak the response of the mixer.

Alignment

To set the tuning of the voltage controlled crystal oscillator, hook a frequency counter to the test point adjacent to the coax jumper cable. With the front panel PBT knob fully clockwise, adjust C24 for 15.3020 MHz. Now with the PBT knob centered, adjust R18 for a reading of 15.300 MHz.

To peak the three adjustable coils, tune in a test signal and watch either the S-Meter or use an audio level meter to adjust the output for maximum.

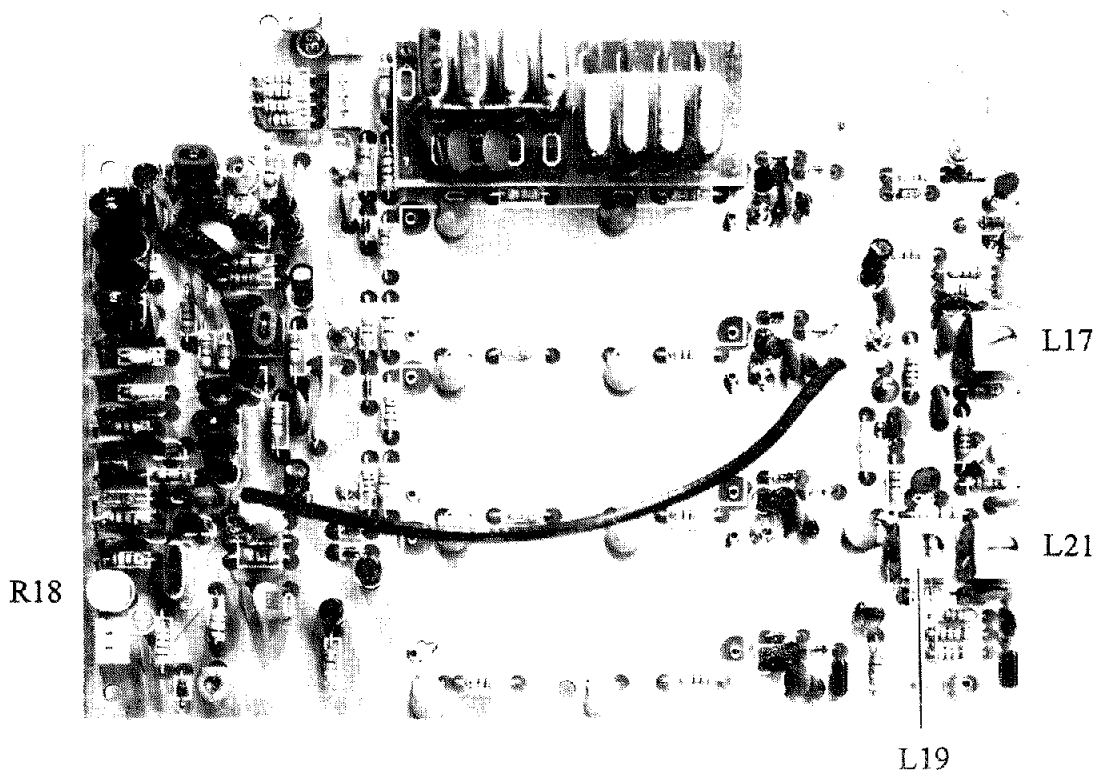
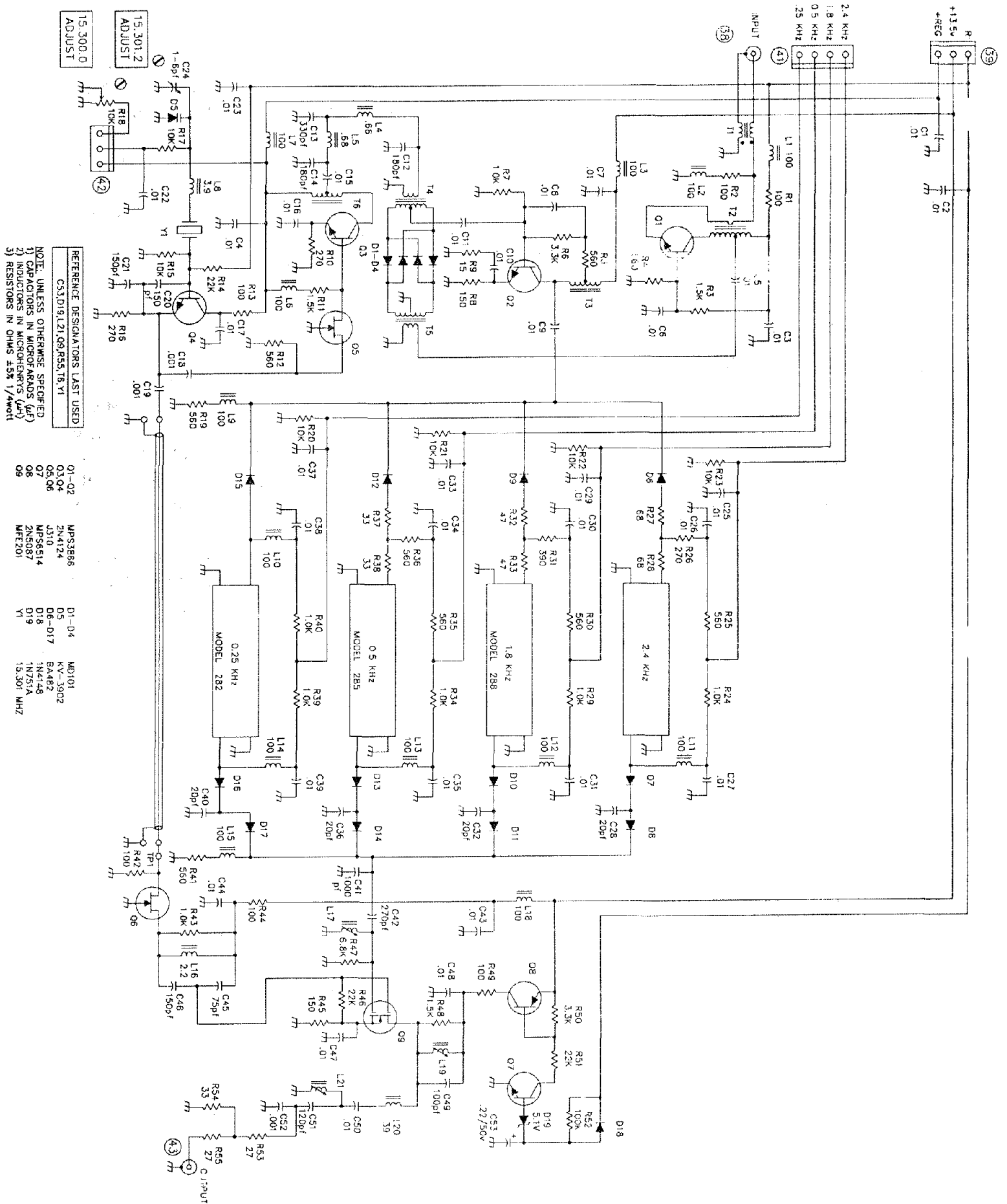

FIGURE 4-9. PBT. BOARD COMPONENT LAYOUT (81600)



NOTE: UNLESS OTHERWISE SPECIFIED
 1) CAPACITORS IN MICROFARADS (UF)
 2) INDUCTORS IN MICROHENRYS (UH)
 3) RESISTORS IN OHMS ±5% 1/4WATT

- REFERENCE DESIGNATORS LAST USED
- | | | | | |
|--------------------------|-------|---------|--------|------------|
| C53,D16,L21,O9,R55,T6,Y1 | 01-02 | WPS3866 | D1-D4 | MD101 |
| | 03,04 | 2N4124 | D5-D17 | KV-3902 |
| | 05,06 | UJ10 | D18 | BA422 |
| | 07 | WPS6514 | D19 | 1N751A |
| | 08 | 2N6987 | | 1N751A |
| | 09 | MFE201 | | 15,301 MHZ |
| | | | | |

FIGURE 4-10. PASS BAND TUNING BOARD SCHEMATIC (81600)

4-7 IF /AF BOARD (81602)

The IF / AF module consists of three stages of IF gain, the AGC system, product detector and the audio circuitry.

Receiver IF signals from the Pass Band Tuning board enter at connector 43. Grounded gate JFET Q1 forms the first amplifier stage. The AGC voltage fed back to Q2 controls pin attenuator diode D1 which limits the peak - to - peak signal level at the input of U1. Integrated circuit IF amplifiers U1 and U2 contribute most of the gain in the entire receiver. These two amplifiers are also controlled by the AGC voltage. Q3 buffers the output of the last amplifier and drives the product detector U3 and the AGC rectifiers D6 and D7. The AGC time constants are set by R21, C30, R22 and C27. The AGC FAST/SLOW/OFF switch connects at terminal 49.

The product detector U3 mixes the IF signal with the BFO from connector 46. The audio output at pin 6 is then filtered and applied to a switched capacitor notch filter U5. The notch frequency is determined by the clock rate from VCO chip U6. This is set by the control voltage from the front panel NOTCH knob at connector 53.

Analog switch U7A and U7C form a SPDT switch under the control of the Logic board. Audio from either the FM detector at connector U or the notch filter is selected and routed

to the DSP interface chip through connector 56. Processed audio from the DSP circuitry then returns at connector 54.

The volume is set by the front panel AF GAIN knob at connector 55. A separate path around the AF GAIN control is provided by U7B. This switch is used to make the CW sidetone independent of the knob setting. Audio amplifier U8 provides up to 1.5 Watts to either the internal or an external speaker.

Alignment

Alignment procedures for the IF / AF board are rather simple. Adjustable coils L3 and L5 peak the gain of the two IF amplifiers. Use either a steady off the air CW carrier or a signal generator and peak the S-Meter reading.

S-Meter alignment should be performed only after all the other receiver adjustments have been made, and will require a calibrated amplitude signal source.

Two trimmers, R29 and R25, adjust the S-Meter offset and full scale. Start with a 50 uV signal into the antenna jack and adjust R25 for an S9 meter indication. Next lower the input to 0.80 uV and adjust R29 to read S3. Repeat these two steps several times until there is no interaction.

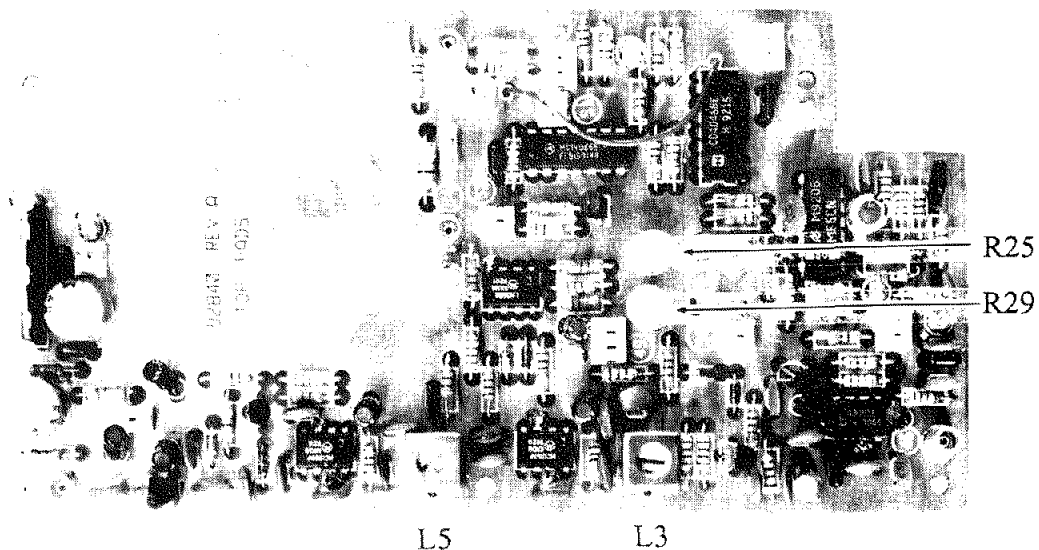

FIGURE 4-11. IF / AF BOARD COMPONENT LAYOUT (81602)

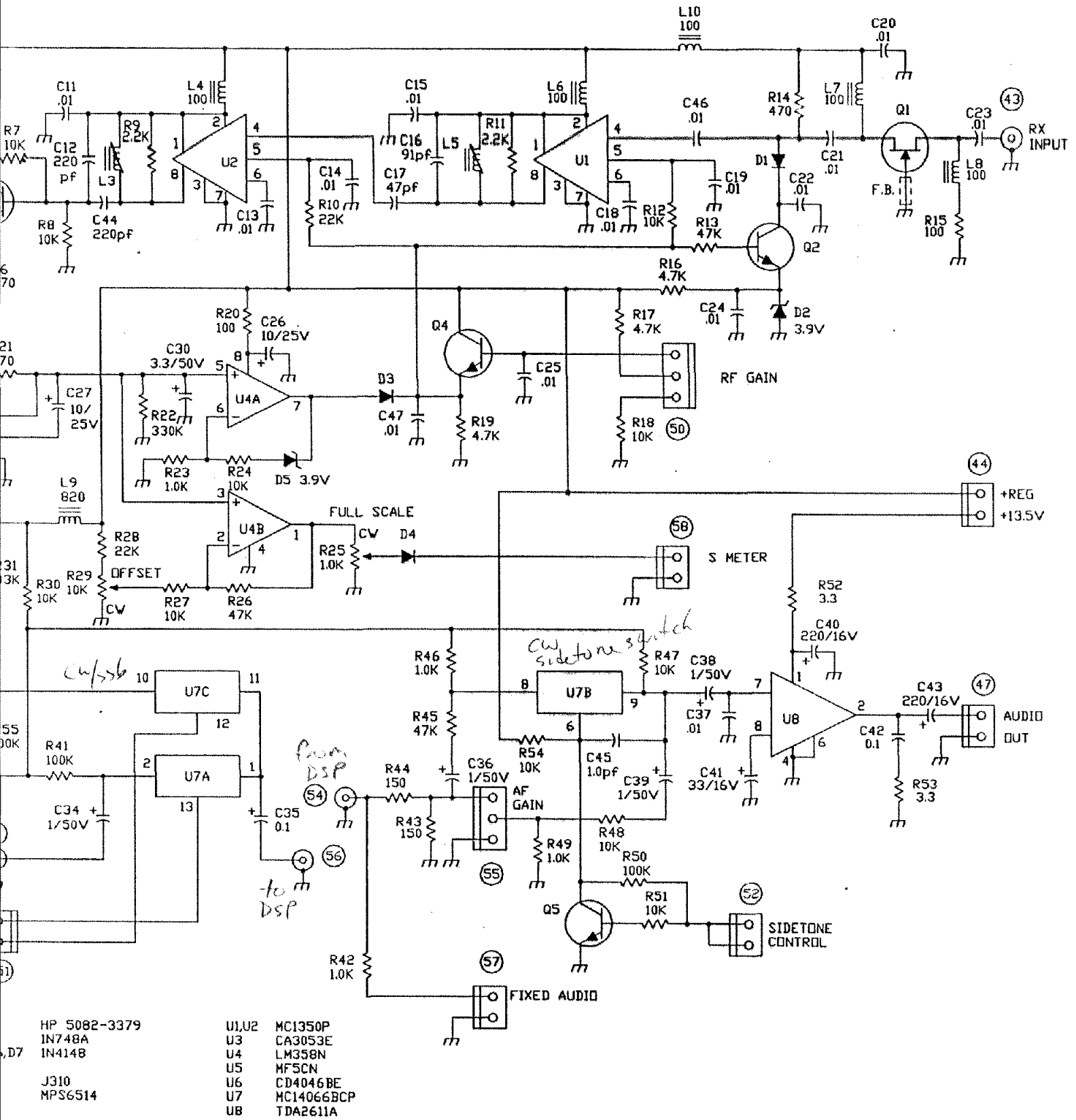
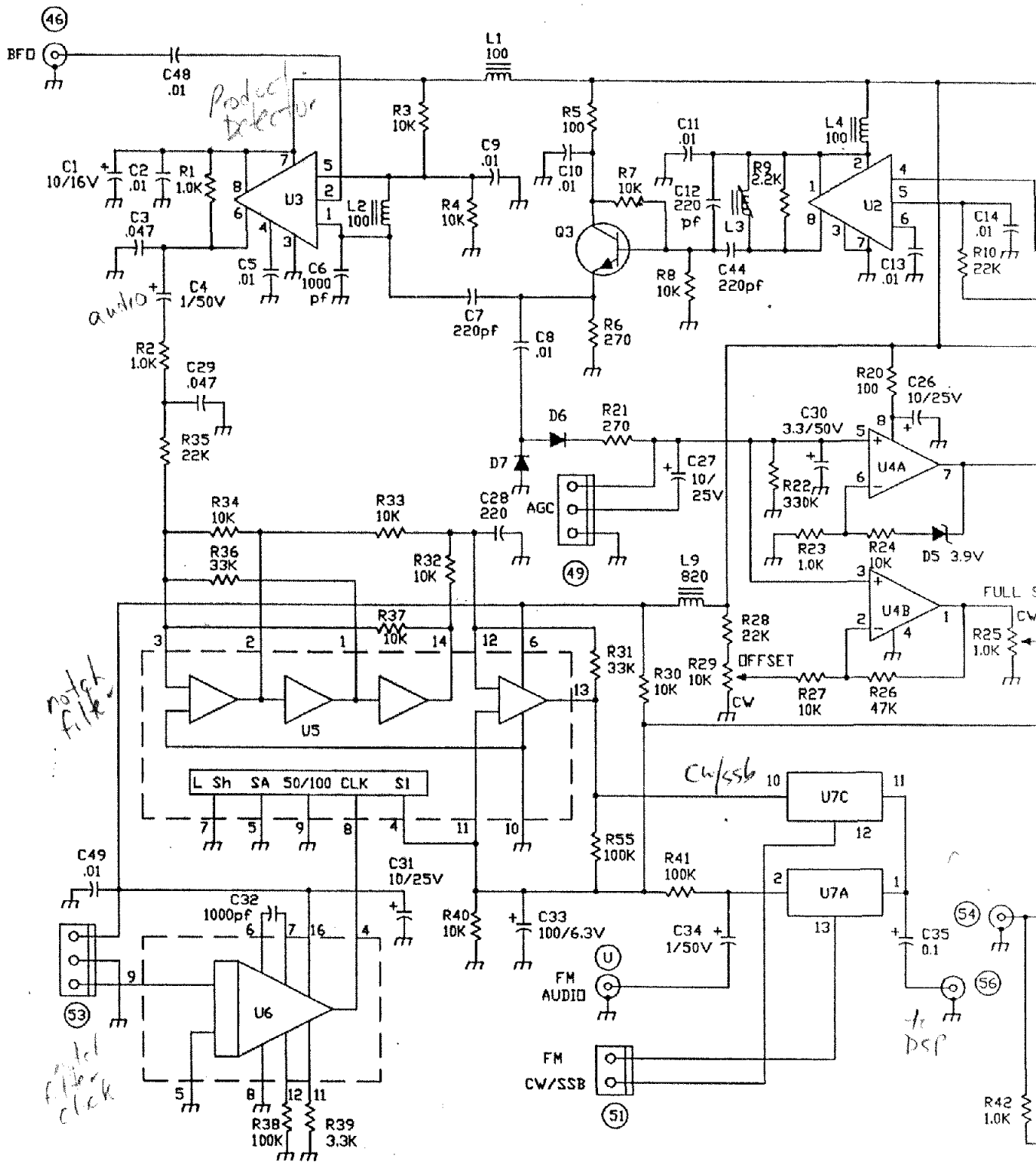

FIGURE 4-12. IF / AF BOARD SCHEMATIC (81602)



REFERENCE DESIGNATORS LAST USED
C49,D7,L10,Q5,R55,U8

NOTE: UNLESS OTHERWISE SPECIFIED
1) CAPACITANCE IN MICROFARADS (μF)
2) INDUCTANCE IN MICRO-HENRYS (μH)
3) RESISTANCE IN OHMS $\pm 5\%$ 1/4w

D1 HP 5082-3379
D2,D5 1N748A
D3,D4,D6,D7 1N4148
Q1 J310
Q2-Q5 MPS6514

U1,U2 MC1350P
U3 CA3053E
U4 LM358N
U5 MF5CN
U6 CD4046BE
U7 MC14066BCP
U8 TDA2611A

FIGURE 4-12. IF / AF BOARD

4-8 5.0 - 5.5 MHZ PLL BOARD (81599)

The phase noise characteristics of the OMNI VI depend entirely on the design of the 5.0 - 5.5 MHz synthesizer. The synthesizer is actually a two loop system that operates at 200 to 220 MHz and tunes in 400 Hz steps. Its output is then divided by 40 to produce the desired 5.0 to 5.5 MHz output. This division by 40 not only reduces the output frequency but also reduces the phase noise and spurious levels by a factor of 32 dB.

The synthesizer's 10 Hz tuning resolution is derived from a voltage controlled crystal oscillator (VCXO) Y1, Q2. Digital information from the microprocessor is clocked in serially at connector 87 and loads the shift register chip U3. The 8 bit output of U3 is applied to an R-2R resistor network, R23, which is used to provide digital-to-analog conversion of the outputs of U3. U4A and U4B buffer the analog output from the resistor network and provide gain and offset adjustments (R27 and R31) to align the frequency of the VCXO.

The VCXO output from Q2 is doubled by T2, D1 and D2, and then heavily filtered before it drives the diode mixer in the feedback path of the main loop. The mixer D3-D6 subtracts the

VCXO frequency from the main loop's output which has been buffered by Q4. This difference signal becomes the feedback for the main loop. Q3 is a filtered amplifier stage which boosts the mixer output to a level sufficient to drive the prescaler chip U5. Since the loop works to keep this feedback signal constant in frequency, the small steps from the VCXO are imposed onto the main loop output.

Reference and divide-by-N dividers in PLL chip U6 are programmed serially from the microprocessor through connector 87. The 10.0 MHz reference signal applied to connector 88 is divided internally in U6 by 1000 to generate a 10 kHz step size. Phase errors from the PLL's phase detector steer the charge pump circuit Q6-Q9. The VCO control voltage from the charge pump is low pass filtered and biases varicap diodes D9 and D10. The VCO output is applied to a two way splitter comprised of T5 and R49, and drives both the mixer buffer stage Q4 and the high speed divide-by-ten chip U7. The output of U7, a square wave of 20 - 22 MHz, clocks a divide-by-four circuit in U8. The 5.0 to 5.5 MHz signal from U8 is then filtered to remove harmonics and exits to the LO mixer board at connector 85.

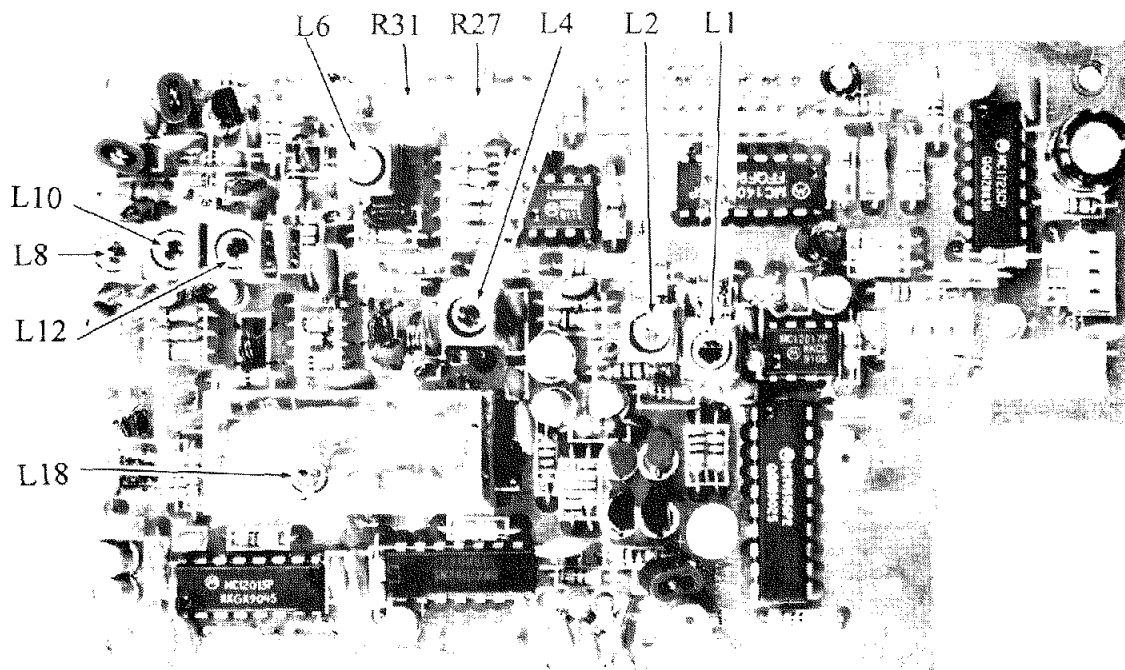
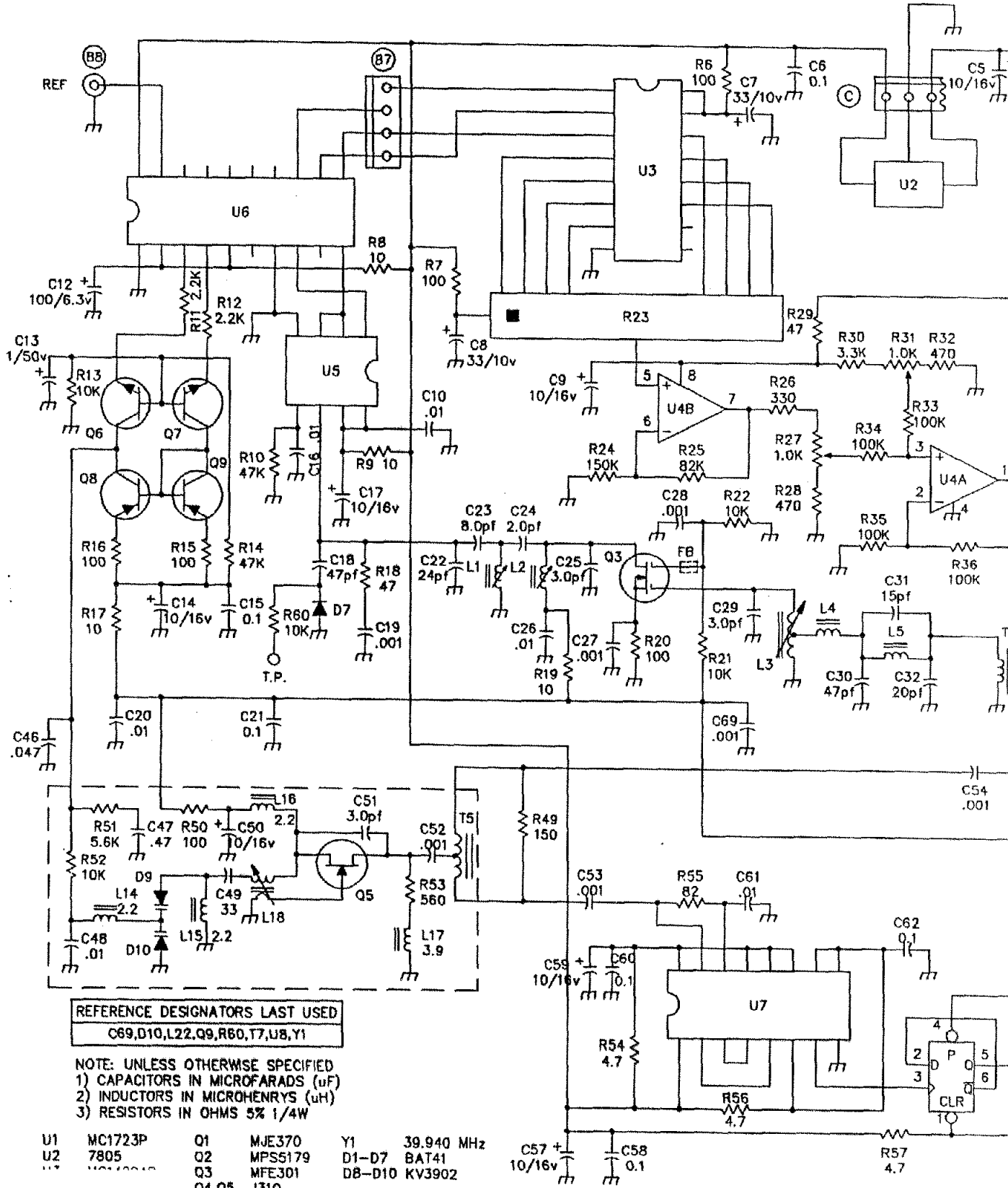

FIGURE 4-13. 5.0 - 5.5 MHZ PLL BD. COMPONENT LAYOUT (81599)



REFERENCE DESIGNATORS LAST USED
 C69,D10,L22,Q9,R60,T7,U8,Y1

NOTE: UNLESS OTHERWISE SPECIFIED
 1) CAPACITORS IN MICROFARADS (uF)
 2) INDUCTORS IN MICROHENRYS (uH)
 3) RESISTORS IN OHMS 5% 1/4W

U1	MC1723P	Q1	MJE370	Y1	39.940 MHz
U2	7805	Q2	MPS5179	D1-D7	BAT41
U3	MC10100	Q3	MFE301	D8-D10	KV3902
		Q4,Q5	J310		
		Q6,Q7	MPS6514		
		Q8,Q9	2N5087		

Part No. 74229
 4th Printing 2/94
 Printed in U.S.A.

FIGURE 4-14. 5.0 - 5.5 MHz PLL BOARD SC

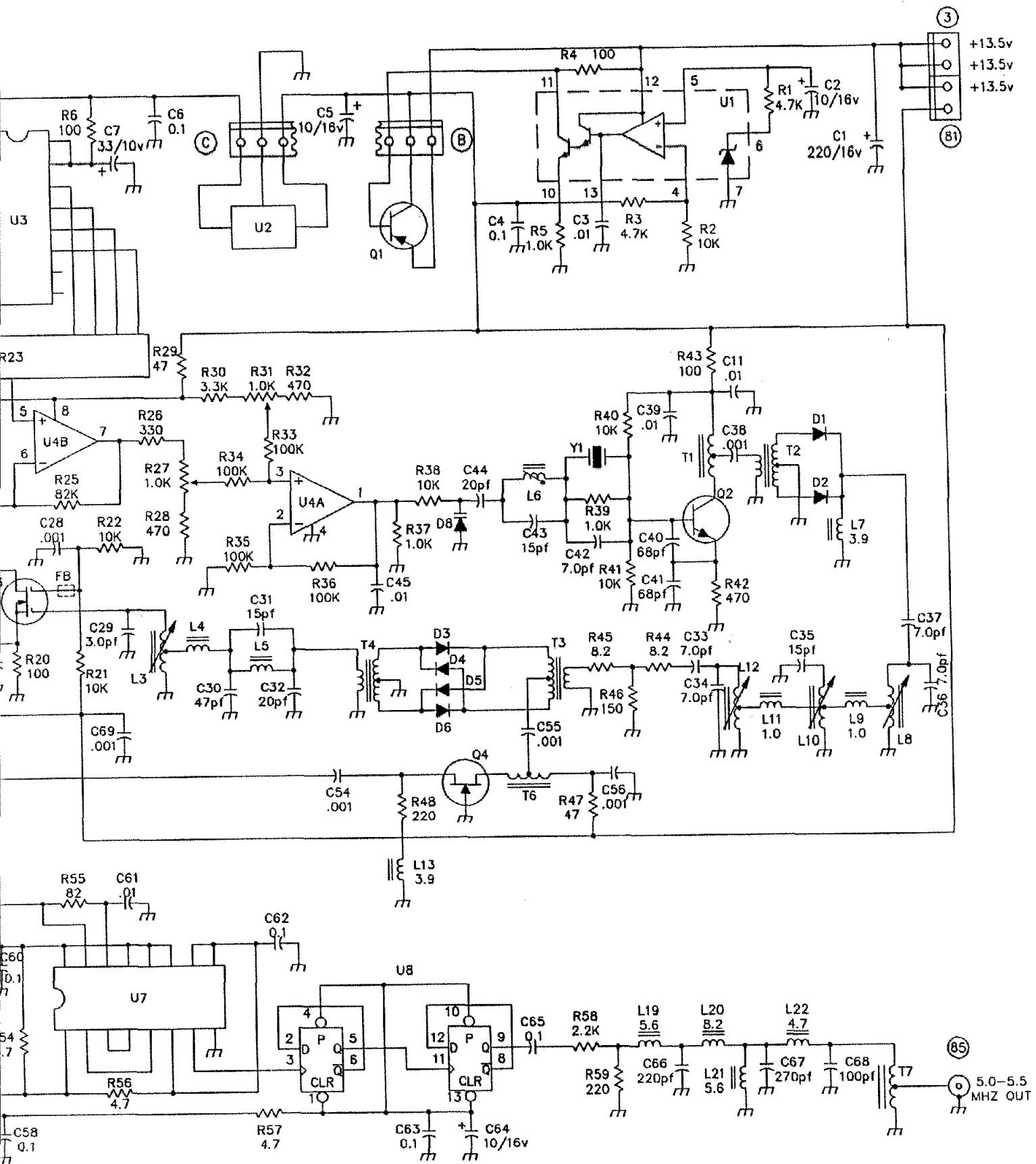

4. 5.0 - 5.5 MHZ PLL BOARD SCHEMATIC (81599)

4-9 XTAL OSC. - L.O. MIXER BOARD (81595)

This module generates the main local oscillator signal which is applied to the transmit and receive mixers in the front end. Band switching information from the Logic board enters via connectors 82 and 83. One of the ten crystals is pin diode switched into oscillator stage Q1. Buffer stage Q2 drives one side of the LO mixer through a low pass filter and also drives the oscillator level detector D25, Q3. Transistor Q3 sets the bias point of the oscillator stage to stabilize the oscillator output level and to limit the drive in the crystals for better aging. Part of the crystal oscillator signal is fed through buffer transistor Q9 to the Logic board via connector 84. A PLL circuit on the Logic

board compares this signal to a precision reference frequency and sends a d.c. correction voltage back to the oscillator via connector 84, through R26, R20 to varactor diode D26. This ensures that the crystal oscillator is always locked to a precision reference for improved frequency stability and accuracy.

The synthesized 5.0 to 5.5 MHz signal at connector 85 is mixed with the crystal oscillator signal by active mixer U1. The desired mixer product is filtered by one of five band pass filters and then amplified by transistors Q6, Q7 and Q8. The L.O. output is then taken off through a 9 MHz trap, T5 and C63, which helps eliminate undesired products from the mixer, which could leak into the receiver IF.

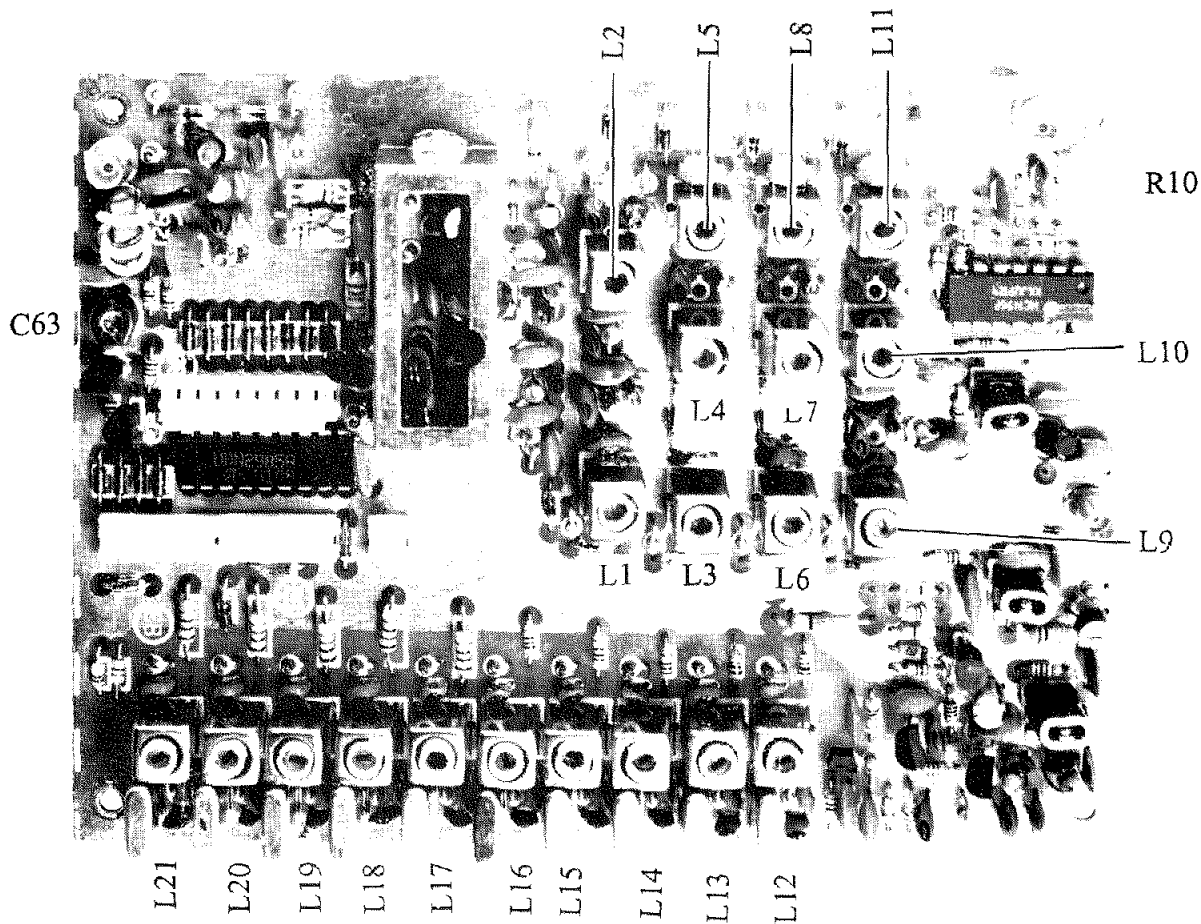
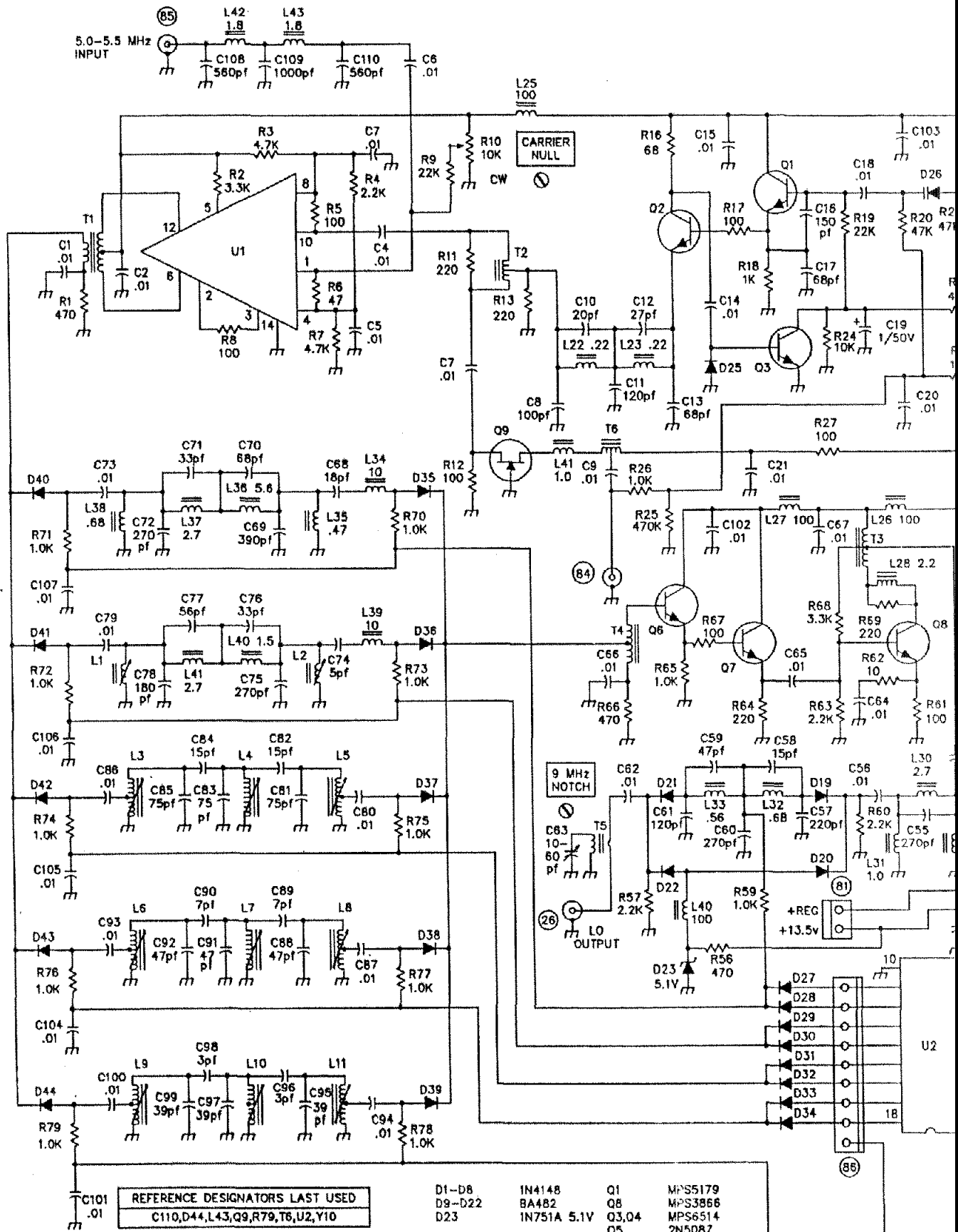

FIG. 4-15. XTAL OSC. - L.O. MIXER BD. COMPONENT LAYOUT (81595)



REFERENCE DESIGNATORS LAST USED
 C110, D44, L43, Q9, R79, T6, U2, Y10

NOTE: UNLESS OTHERWISE SPECIFIED
 1) CAPACITORS IN MICROFARADS (uF)
 2) INDUCTORS IN MICROHENRYS (uH)
 3) RESISTORS IN OHMS 5% 1/8W

D1-D8	1N4148	Q1	MPS5179
D9-D22	BA482	Q8	MPS3866
D23	1N751A 5.1V	Q3, Q4	MPS6514
		Q5	2N5087
D25	BA141	Q2, Q6, Q7	2N4124
D26	SVC321SPA	Q9	J310
D27-D34	1N4148	U1	MC1496P
D35-D44	BA482	U2	UDN2985

Part No. 74229
 4th Printing 2/94
 Printed in U.S.A.

FIGURE 4-16. XTAL OSC. - L.O. MIXER

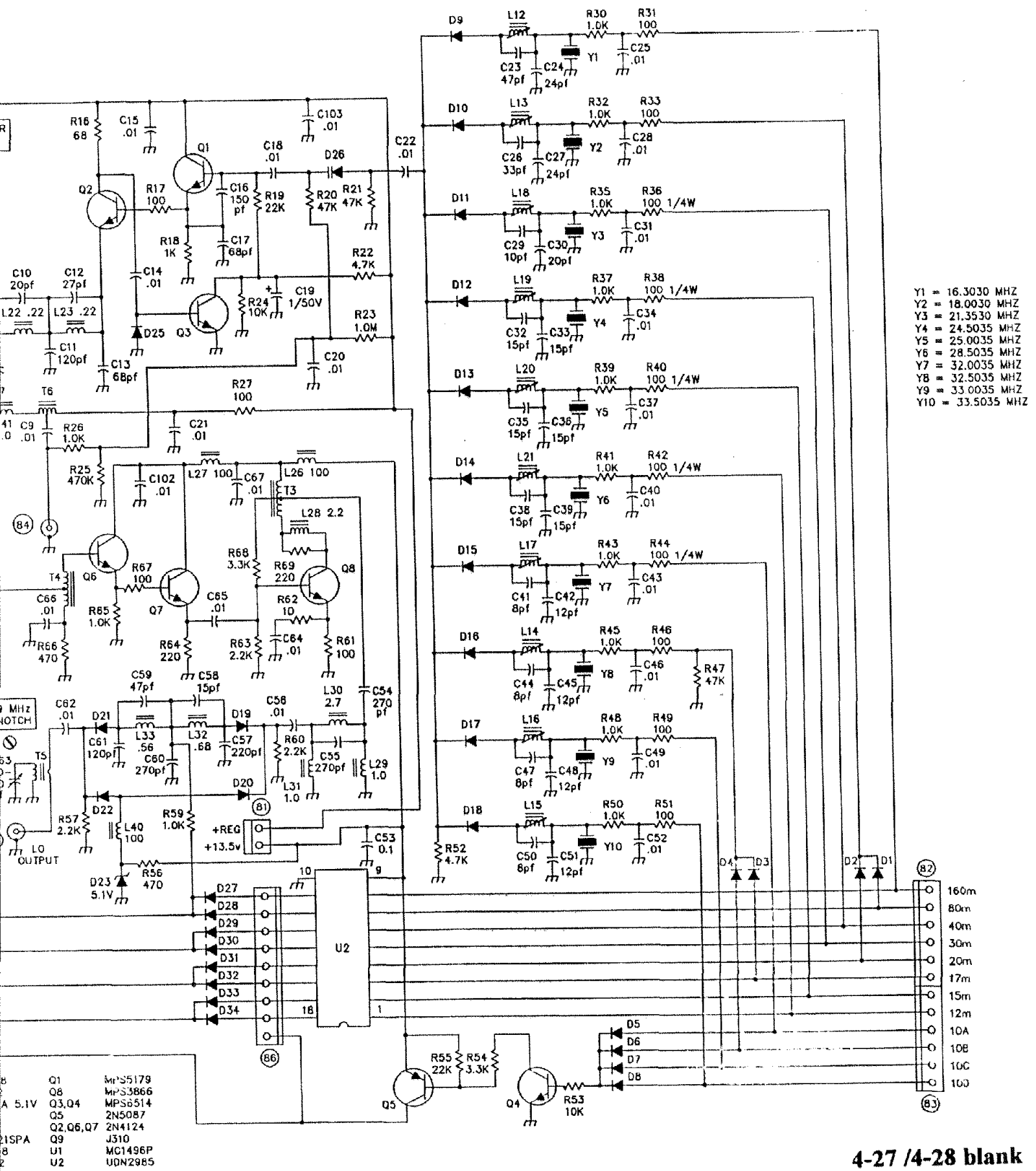

4-27 / 4-28 blank

4-16. XTAL OSC. - L.O. MIXER BOARD SCHEMATIC (81595)

4-10 CONTROL BOARD (81596)

This module contains diode and transistor logic circuitry to develop control voltages based on inputs from the Logic board, rear panel control jacks, or front panel switches, that determine the mode of operation (SSB, CW, transmit, receive, etc.) of the various circuits in the transceiver. It also contains the adjustable CW wave shaping circuit that sets the rise and fall times of the transmitted CW envelope.

The main mode information from the Logic board enters at connector 59. "T" voltage (indicating transmit mode) enters at connector 61 from the Low Level/N.B. board. These inputs are combined in diode-transistor logic circuits D1-D13 and Q1-Q7 to form mode outputs to the IF/AF and TX Audio boards via connectors 51 and 60.

A request to key the transmitter is generated by grounding the PTT (rear panel or microphone via Switch board connector 65) or CW KEY lines, or a VOX output from the Logic board, which forward biases Q9, sending a high level TXRQ signal to the microprocessor on the Logic board via connector 66. The microprocessor processes the request signal and generates a TX ACK signal on connector 63, which turns on Q11, pulling the center pin of the rear panel TX OUT connector to ground. Normally the TX OUT connector is jumpered to the TX ENable connector and the low level from Q11 is passed directly to keying waveshape circuit Q12-Q15. An external keying interlock loop may be substituted for the jumper between TX OUT and TX ENable. Such an interlock may be used to prevent "hot switching" of a QSK linear amplifier, for example.

The keying waveshape circuit Q12-Q15 is an adjustable integrator that slows down the rise and fall times of the keying voltage "TD" which is sent to the T/R generator on the Low Level Driver/N.B. board via connector 61, and

to the balanced modulator on the TX Audio board via connector 60. CW waveshape adjustment R24 sets the keying rise and fall times in the range of 1-5 mS. This waveshaping has little effect on the T/R generator since its switching threshold is below 1 Volt. The balanced modulator, however, has a more gradual increase in gain as "TD" goes high, thus transferring the slowed rise and fall times to the transmitted keying waveform.

During transmit the Logic board sets the RELAY line at connector 59 high which turns on relay K1 through transistor Q16. This relay provides a ground at the center pin of the rear panel RELAY connector during transmit. The hold-in time for CW operation is software adjustable from the front panel keypad.

Transistors Q18 and Q17 provide dot and dash signals for the built-in electronic CW keyer via connector 64 which goes to the Logic board. Control signals for Q18 and Q17 come from rear panel mounted jack J8 which is designed to be connected to separate dot and dash keyer paddles. The built-in keyer has software adjustable speed and weighting via the front panel keypad. Alternately, an external keyer or keyboard may be connected to the rear panel KEY jack to key the transmitter in any operating mode.

Transistor Q10 and rear panel MUTE jack provide for footswitch operation of the T/R switching. Whenever the MUTE line goes to ground, a MUTE RQ signal is developed and sent to the Logic board via connector 66. This causes the transceiver to be placed into transmit mode, except that NO RF IS APPLIED until either the KEY or PTT lines are grounded.

Cables 4/4, 9/10, 20/21, 35/36, 39/40, 44/45, and 61/62 distribute T, R, +REG, and +13.5 Volts to several boards. Wires in these cables are color coded as follows: T - blue, R - yellow, +REG - orange, +13.5V - red.

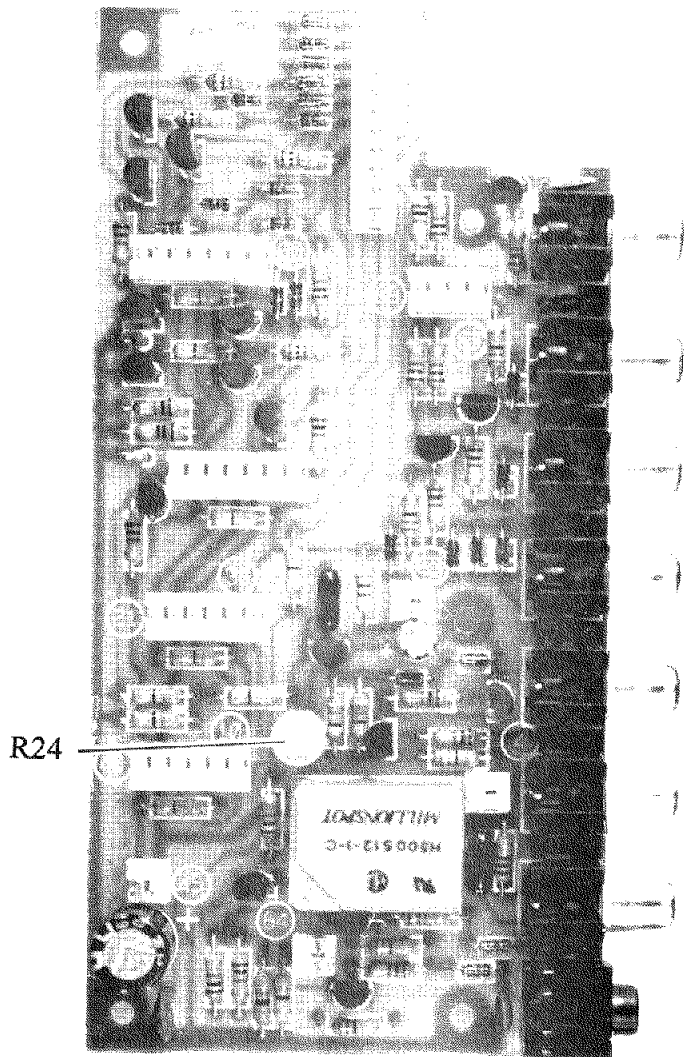
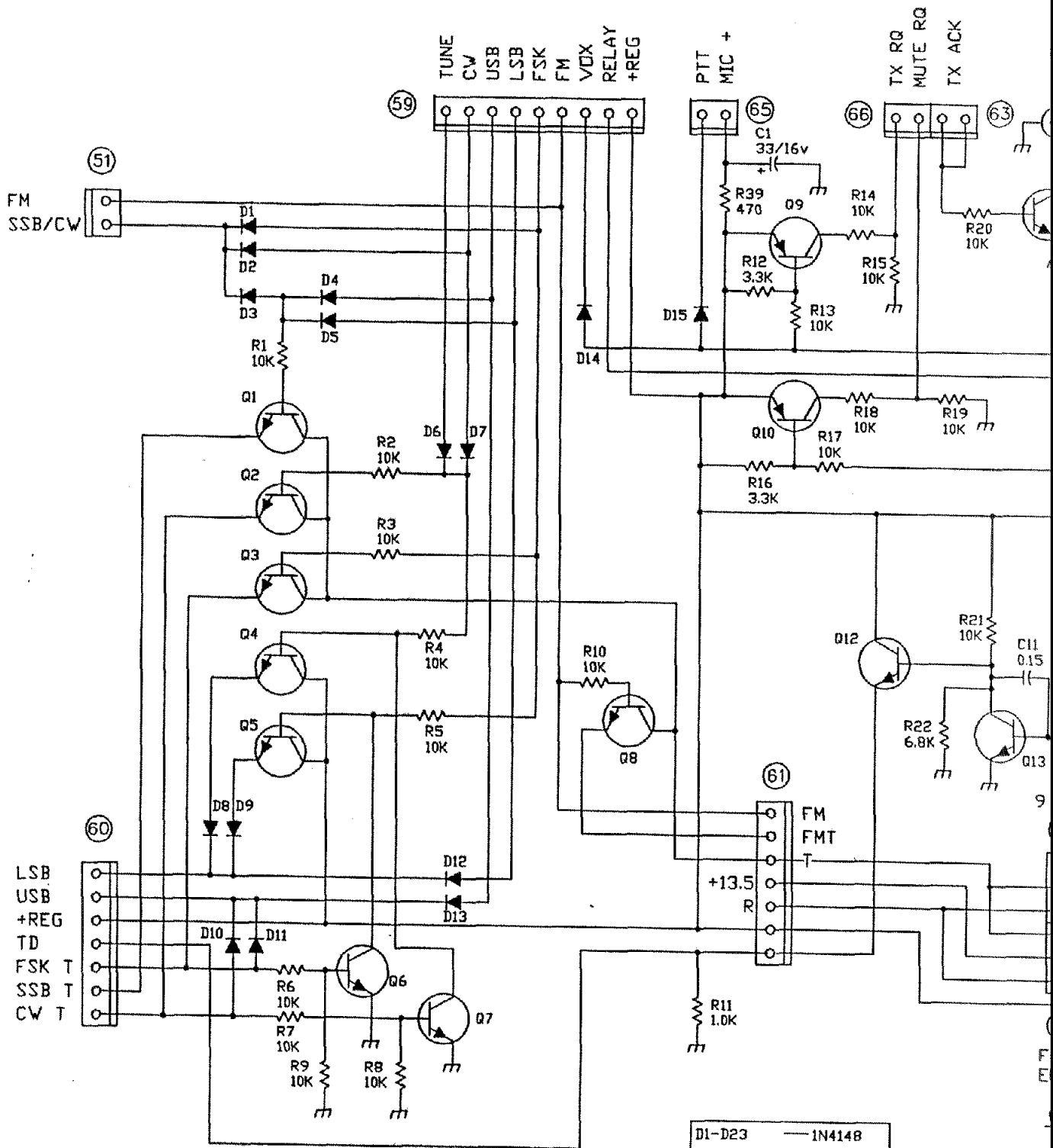

FIGURE 4-17. CONTROL BOARD COMPONENT LAYOUT (81596)



REFERENCE DESIGNATORS LAST USED
 C14, D23, J8, K1, Q18, R39

NOTE; UNLESS OTHERWISE SPECIFIED
 1) CAPACITORS IN MICROFARADS (μF)
 2) INDUCTORS IN MICROHENRYS (μH)
 3) RESISTORS IN OHMS ±5% 1/4W

D1-D23	— 1N4148
Q1-Q8	— MPS-6514
Q11-Q14, Q16	
Q9, Q10	— 2N5087
Q15, Q17, Q18	

Part No. 74229
 4th Printing 2/94
 Printed in U.S.A.

FIGURE 4-18. CONTROL BOARD SCH

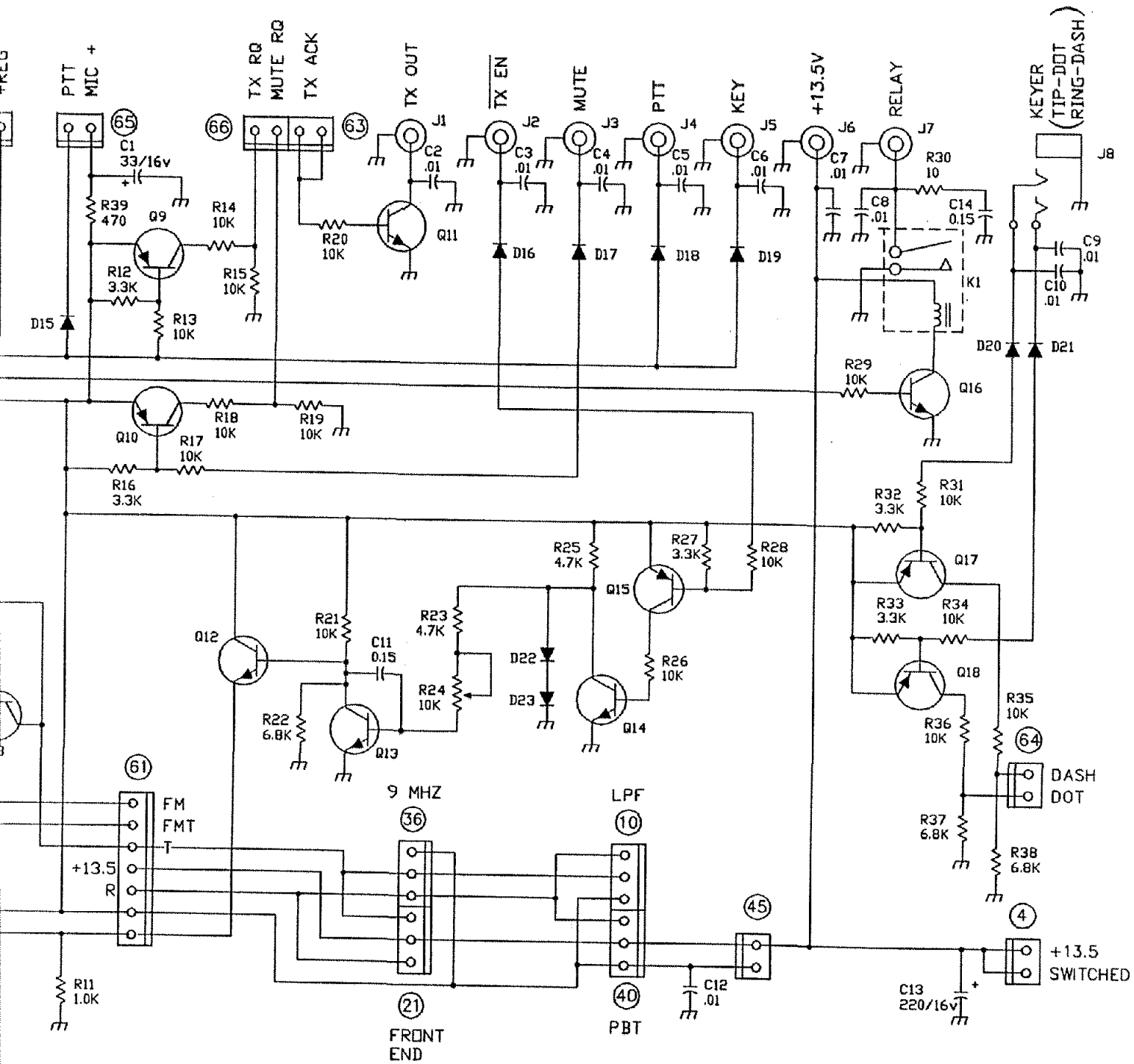

D1-D23	— 1N4148
Q1-Q8	— MPS-6514
Q11-Q14, Q16	
Q9, Q10	— 2N5087
Q15, Q17, Q18	

LOW PASS	PASSBAND TUNING	FRONT END	9 MHz FILTER/ALC
○ R	○ R	○ T	○ +REG
○ T	○ +13.5	○ +13.5	○ T
○ +REG	○ +REG	○ R	○ R

4-18. CONTROL BOARD SCHEMATIC (81596)

4-31 / 4-32 blank

4-11 LOGIC BOARD (81606)

This module integrates the LOGIC, DSP and CRYSTAL LOCKING subsystems onto a single pc board. An 80C32 microprocessor (U1) operating at 20 MHz, a 32k EPROM (U4) and 8K of battery backed RAM (U5) form the core of the logic system. The 80C32 processor is a member of the 80C51 family of processors and contains 256 bytes of on-chip ram, two 16 bit counter/ timers, full duplex serial interface and multiple interrupt capability. A 74HC573 latch (U2) performs address demultiplexing and a 74HC138 (U3) provides address decoding for the bus-oriented peripherals. In addition to the EPROM (ROM space \$0000-\$7FFF) and RAM chip (RAM space \$4000-\$5FFF), the logic system core also includes a real time clock (U6 RAM space \$E000), an Analog to Digital converter (U7 RAM space \$2000) and 82C55 I/O expander (U20 RAM space \$0000). The DSP subsystem is memory mapped into the microprocessor RAM space at address \$A000 and the Optional Voice Board is memory mapped to \$C000. Also included on the Logic board are a serially programmed 32 bit high current driver (U22) which provides band switching signals for the transceiver and controls front-panel keypad indicators. The DSP sub-system is comprised of integrated circuits U8, U9, U10, U11, U16 and U23. The DSP subsystem is based on the ANALOG DEVICES ADSP 2105 DSP PROCESSOR with a cycle time of 100 nanoseconds. A 27C64 EPROM (U9) contains the DSP program which is loaded into the 2105's internal ram during system power-up. A serial CODEC (U11) provides the Analog to Digital and Digital to Analog functions of the DSP system and anti-alias filtering with a pass band of 200 Hz - 3400 Hz. U23 and transistor Q13, and diodes D4, D5 provide the 5V required by the CODEC. Receiver audio reaches the DSP sub-system via coax connector 54 and exits the DSP sub-system via connector 56. The DSP processor RESET line, is connected to the main microprocessor via U20 which allows the Microprocessor to perform the DSP sub-system re-

set during power-up.

IC U16, a 7400 NAND GATE and IC U8, an 8 bit LATCH provides the interface to the DSP PROCESSOR bus with the Main microprocessor bus. The interface provides a one-way (MICROPROCESSOR to DSP) interface. The write signal from the microprocessor also provides an interrupt to the DSP processor to inform the DSP subsystem that a new command has been received.

IC's U17, U18, U19 are used to interface the MAIN, REMOTE and OFFSET encoders to the Microprocessor. U19 is used to ensure smooth operation of the offset encoder by cleaning-up the encoder pulses before they reach the microprocessor. ICs U17 and U18 in conjunction with resistors R30, R31, capacitors C25, C26 and diodes D2, D3 operate to provide an interrupt pulse for each phase change generated by the encoders. When the microprocessor receives this interrupt request signal, the software tuning routines analyze the encoder signals to determine which encoder is moving and in which direction by reading the encoder positions via the 82C55 I/O expander. IC U21 interfaced via U20 to the microprocessor, provides the keyboard scan interface for reading keypad status. Serial interface circuitry based on U14 and TRANS??? provides level Q18-Q11 translation for RS-232 and TTL levels via connectors 72 and 69. Transistors Q1 and Q2 form a 20 MHz oscillator which provides the 20 MHz processor clock and after dividing down provide the 10 MHz minor loop reference and the 5 MHz clock to the DSP CODEC. U13, a serially programmed PLL IC provides the Crystal Locking control. A sample of the selected Band crystal is fed to the PLL via connector 84, an error signal is generated by the PLL chip and the crystal frequency is adjusted as necessary via the charge pump circuit which feeds a DC correction voltage back over the RF sampling line. A varactor diode located on the crystal board provides the necessary crystal adjustment.

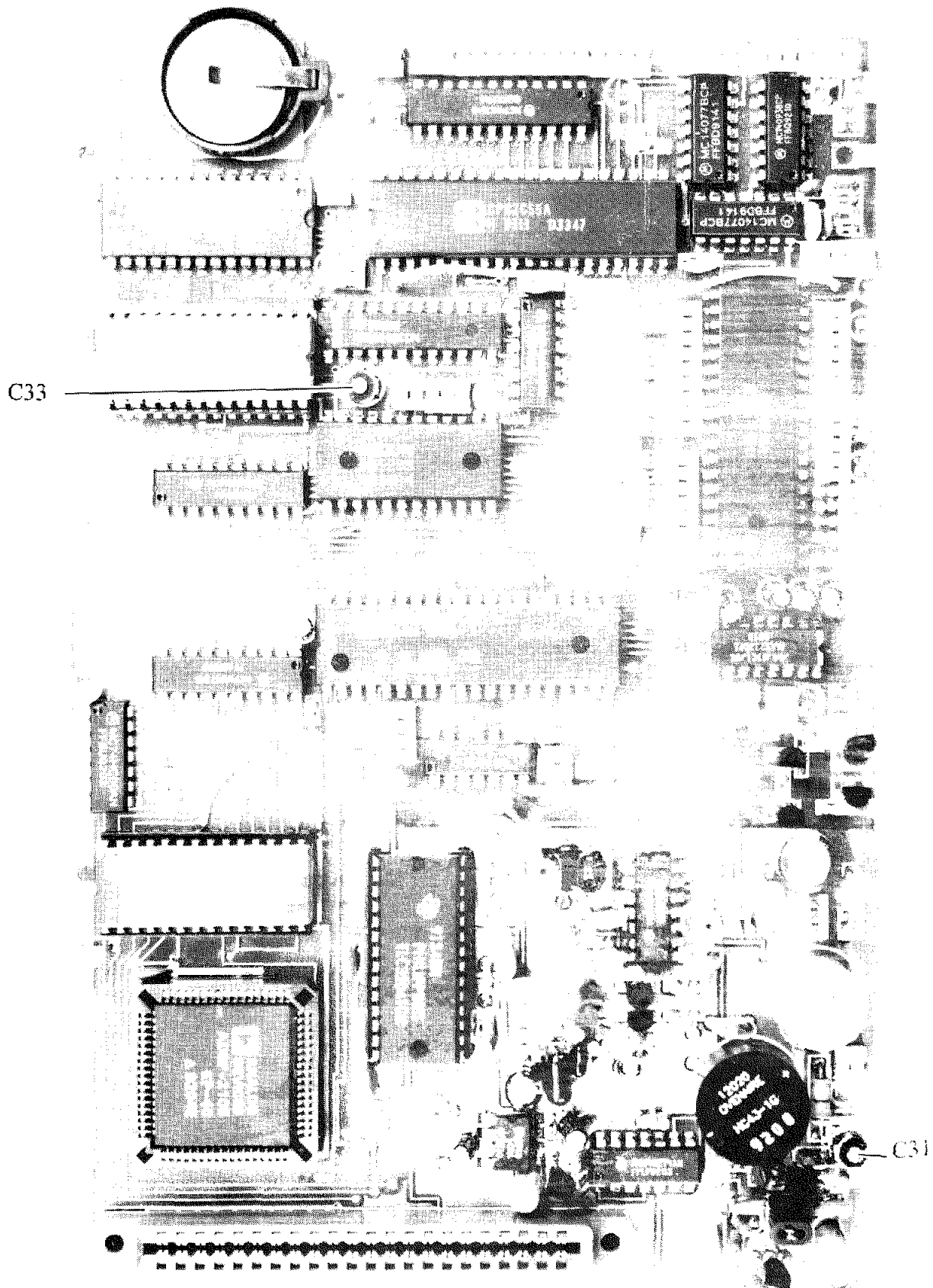
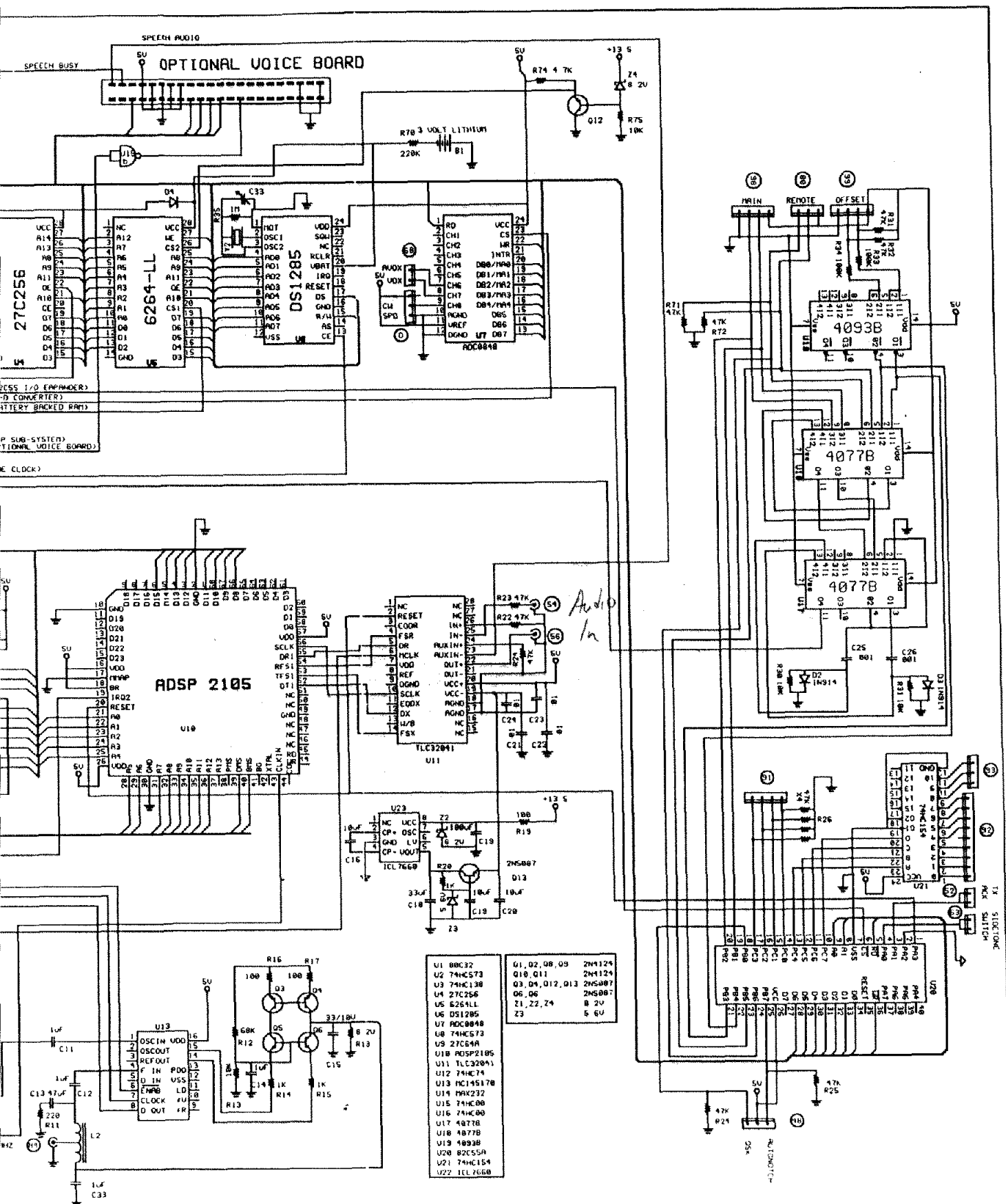

FIGURE 4-19. LOGIC BOARD COMPONENT LAYOUT (81606)



U1	68C32	U10	ADSP2105
U2	74HC573	U11	TLC320A1
U3	74HC138	U12	74HC74
U4	27C256	U13	NC145178
U5	6264LL	U14	MAX232
U6	DS1285	U15	74HC00
U7	ADC0848	U16	74HC00
U8	74HC573	U17	48778
U9	27C64A	U18	48778
U10	ADSP2105	U19	48938
U11	TLC320A1	U20	82C55A
U12	74HC74	U21	74HC154
U13	NC145178	U22	TCL7660
U14	MAX232		
U15	74HC00		
U16	74HC00		
U17	48778		
U18	48778		
U19	48938		
U20	82C55A		
U21	74HC154		
U22	TCL7660		

LAST USED DESIGNATORS
 C33, R75, D4, 24, Y2, L3, D13
 U22

LOGIC BOARD 81606

20. LOGIC BOARD SCHEMATIC (81606)

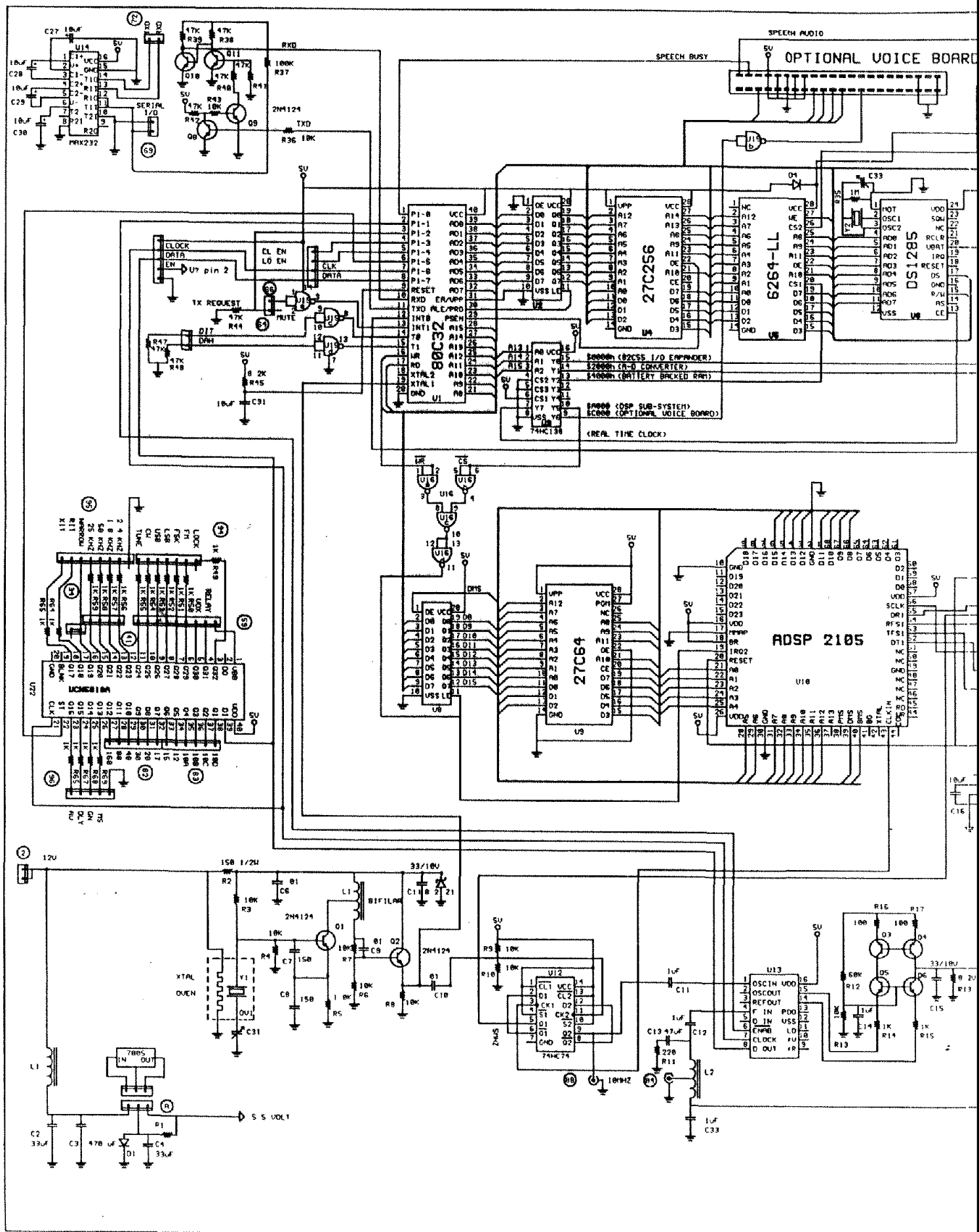

FIGURE 4-20. LOGIC BOARD SCHEMATIC (8)

4-12 LED DISPLAY BOARD (81587)

This module contains three groups of 7-segment LED displays. Also on this module is an array of 4 LEDs used to annunciate various display modes currently in use.

Frequency information is displayed on DSP1 through DSP4. These LEDs are .56" high, common cathode displays driven by multiplexed segment and digit signals from the LED Display Driver board via connector strip P1. This connector also provides drive signals for the annunciators LED1 through LED4.

Offset, time, and memory channel information is displayed in two groups of smaller .3" high LEDs consisting of DSP5 through DSP12. Multiplexed drive signals from the LED Display Driver board are connected to these displays via connector strip P2.



FIGURE 4-21. LED DISPLAY BOARD COMPONENT LAYOUT (81587)

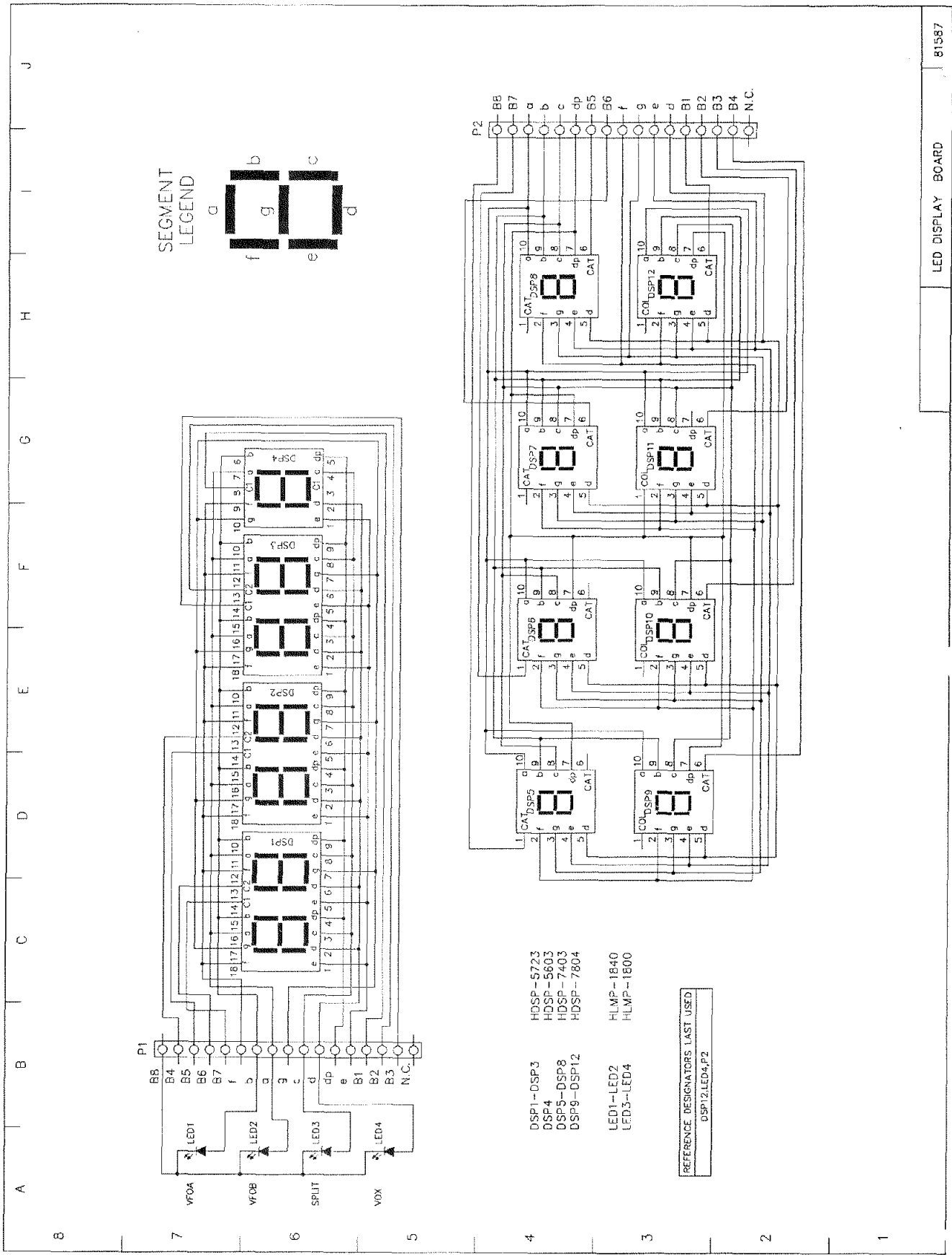

FIGURE 4-22. LED DISPLAY BOARD SCHEMATIC (81587)

4-13 LED DISPLAY DRIVER BOARD (81588)

This module contains two intelligent LED display driver chips, IC1 and IC2. Display data from the Logic board is clocked in serially to IC1 via connector 90. The LOAD line is initially set low, then each driver chip receives 16 bits of serial data. Since the chip's data lines are cascaded (DOUT of IC1 goes into DIN of IC2), a continuous string of 32 bits is clocked into DIN of IC1. The LOAD line is then pulsed high to latch the data in the driver chips. Each

chip contains its own internally generated multiplex clock and LED driving circuits. IC1 controls the larger .6" high frequency readout and the four small LED annunciators, while IC2 controls the two smaller groups of .3" high LED displays used to display offset, time, and memory information. Display brightness is user selectable and controlled by commands from the Logic board. Digit drive signal DG7 from IC1 is routed via connector 89 to the Low Level Driver/ N.B. board where it is used to adjust the brightness of the meter lamp.

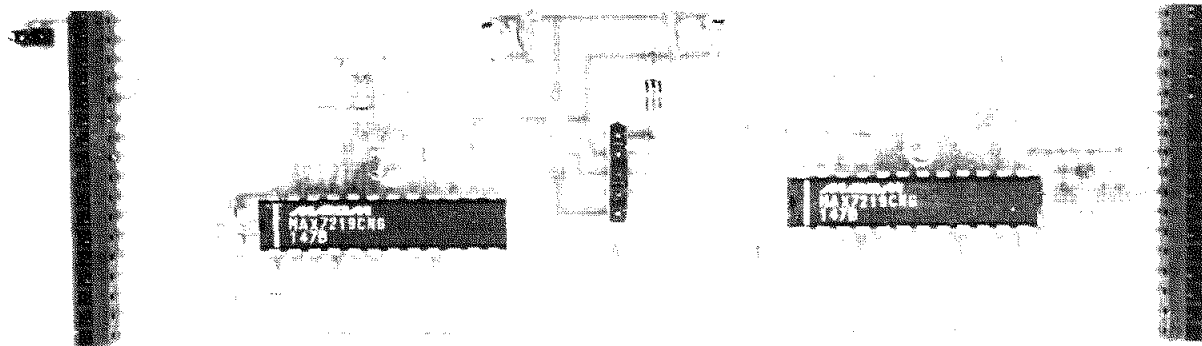

FIG. 4-23. LED DISPLAY DRIVER BD. COMPONENT LAYOUT (81588)

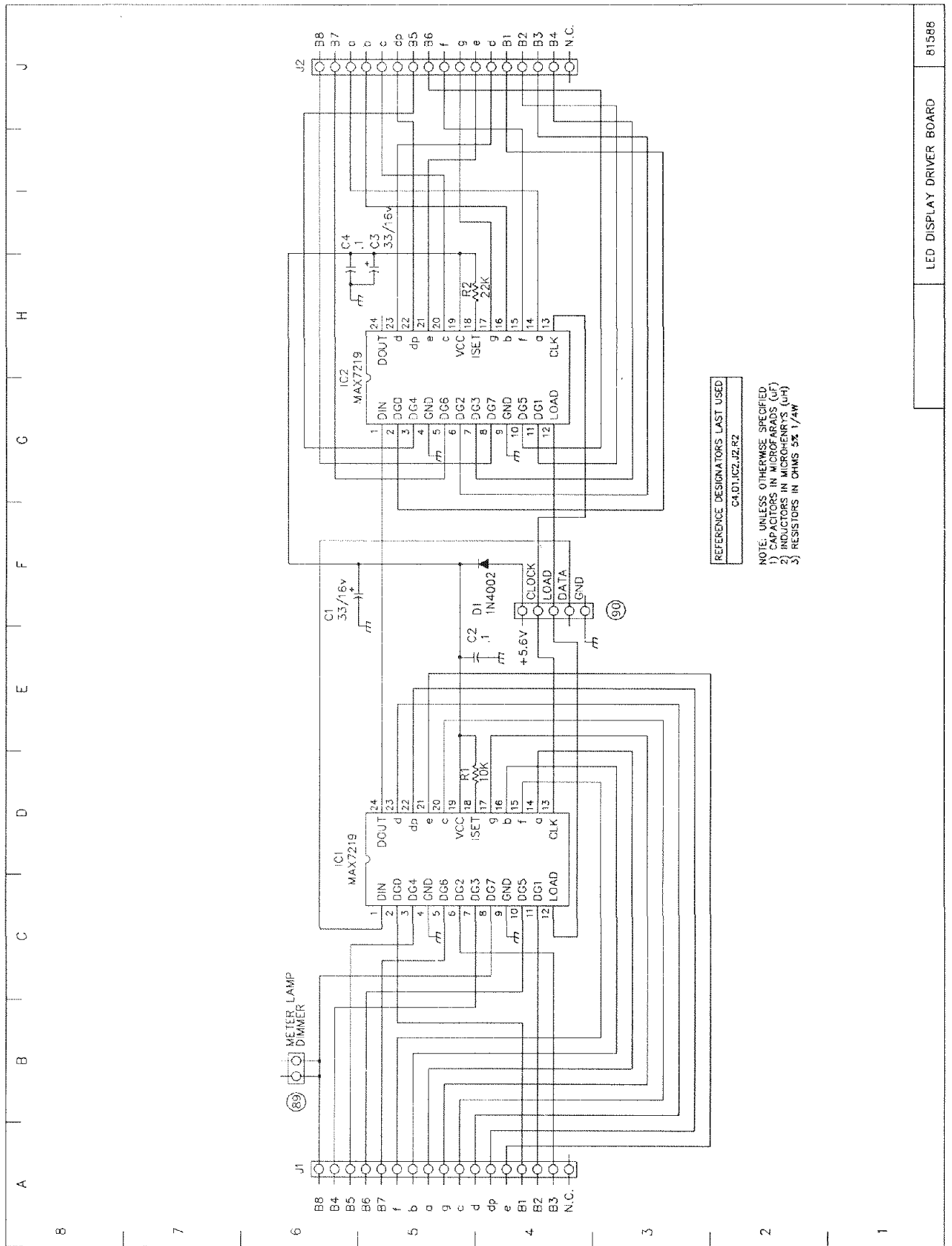

FIGURE 4-24. LED DISPLAY DRIVER BOARD SCHEMATIC (81588)

4-14 TX AUDIO BOARD (81597)

This module contains the transmit audio amplifiers, speech processor, 9 MHz BFO and balanced modulator. It is located at the left rear of the chassis, on top of the chassis deck behind the PLL shield box. There are board mounted connectors for AUDIO IN, AUDIO OUT, MARK/SPACE, SERIAL PORT and INTERFACE PORT accessible through the rear panel.

Microphone audio from connector 73 or transmit audio from the rear panel AUDIO IN jack is amplified by U2A. The output of U2A splits three ways to drive the anode of diode switch D21, the speech PROCESSOR control pot. at connector 74, and the VOX amplifier U3A. Diode D21 is normally forward biased through connector 70 when the PROCessor switch on the Lower Pot. board is in the off position, connecting the amplified audio signal to the MIC gain control at connector 71.

The speech processor input at connector 74 is amplified to a nominal 1.2 Volts peak by U1A and again by U1B to approximately 1.8 Volts peak. One output of U1B drives rectifier D14 and compressor transistor Q13. Q13 clamps part of the original input to ground, effectively maintaining a constant audio level at the output of U1A. Another output of U1B drives the processor level meter through emitter follower Q12 and connector 78.

Half the output of U1A appears across clipper diodes D18 and D19, but no clipping occurs at the normal level of 0.6 Volts. The clipper diodes limit fast audio transients, for which the compressor circuit is less effective, to 0.65-0.7 Volts. The compressed and limited speech processor output level is set by R65, and U2B buffers the output to the anode of diode switch D20. When the PROCessor switch is in the ON position, D21 is reverse biased, D20 is forward biased, and processed audio is passed to the MIC gain control via connector 71. R65 is adjusted so that the peak levels of the processed and the unprocessed

audio signals at connector 71 remain equal as the PROCessor switch is toggled between OFF and ON.

The output of the MIC gain control at the center pin of connector 71 is fed to the balanced modulator U4. The balanced modulator mixes the transmit audio signal with the BFO carrier to produce a 9 MHz double sideband suppressed carrier output. U4 is enabled on pin 7 by "TD" voltage from the Control board connector 60. The balanced modulator gain is increased in SSB mode by grounding bypass network C4 - R10 through Q1. Q2 unbalances the modulator in CW and FSK modes. Tuned transformer T1 performs the match to the 50 Ohm DSB input of the 9 MHz Mixer/IF board at connector 37. R3 and R4 trim the AC and DC balance of U4 for maximum carrier null.

Part of the transmit audio signal is fed through VOX amplifier U3A and emitter follower Q11 and appears at connector 68. Likewise, a portion of the speaker audio is fed through amplifier U3B and emitter follower Q10 to connector 68. These two signals (VOX and ANTI VOX) are sent to the Logic board for processing by the DSP circuits, which provide a software controlled VOX system.

The BFO oscillator/amplifier is formed by transistors Q6-Q8, and its frequency of operation is determined by crystals Y1-Y2, diode switches D8-D12, and capacitors C10-C13, C16, C18. Based on the mode of operation, transistor switches Q3-Q5, Q9 drive the diodes which select trimmer capacitors to set the BFO frequency at the proper place with respect to the IF filter response. Mode information from the Control board enters at connector 60. The trimmers can be set with a high resolution counter at connector 46 by switching modes in the order listed below and adjusting the corresponding trimmer for the frequency indicated:

LSB receive, adjust C10 for 9.000000 MHz.

USB receive, adjust C12 for 9.003000 MHz.

FSK SPACE, adjust C13 for 9.002295 MHz.

FSK MARK, adjust C18 for 9.002125 MHz.

CW transmit or TUNE, adjust C16 for 9.000400 MHz.

NOTE: FSK MARK input voltage can be in the range of 0 to -15 Vdc. FSK SPACE input voltage should be in the range of +2.5 to +15 Vdc for proper operation.

Because of a slight interaction between the trimmers, these adjustments should be repeated at least once.

The BFO output from Q7 splits three ways.

One output drives ALC transistor Q8 which controls the bias of oscillator transistor Q6 to maintain a constant output level. Another output serves as the carrier input to balanced modulator U4. The third BFO output drives the product detector on the IF/AF board through connector 46.

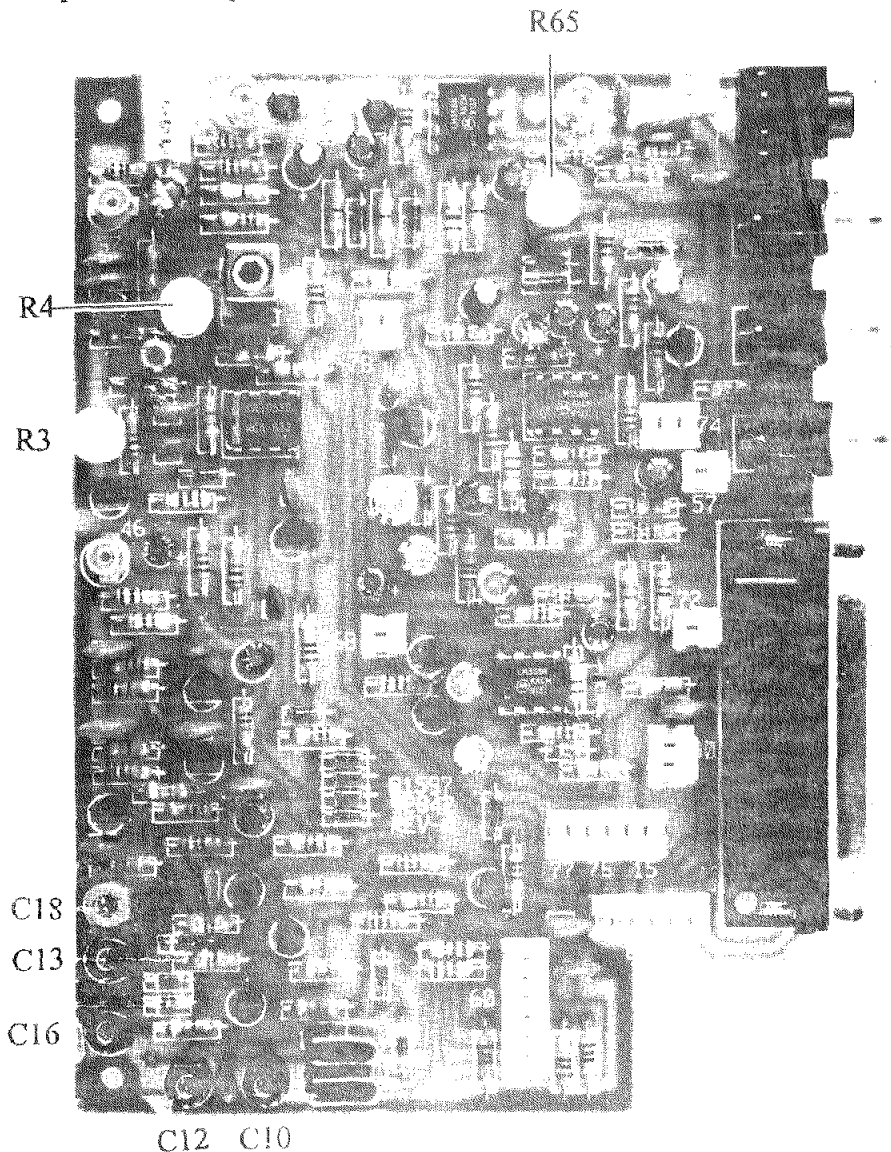
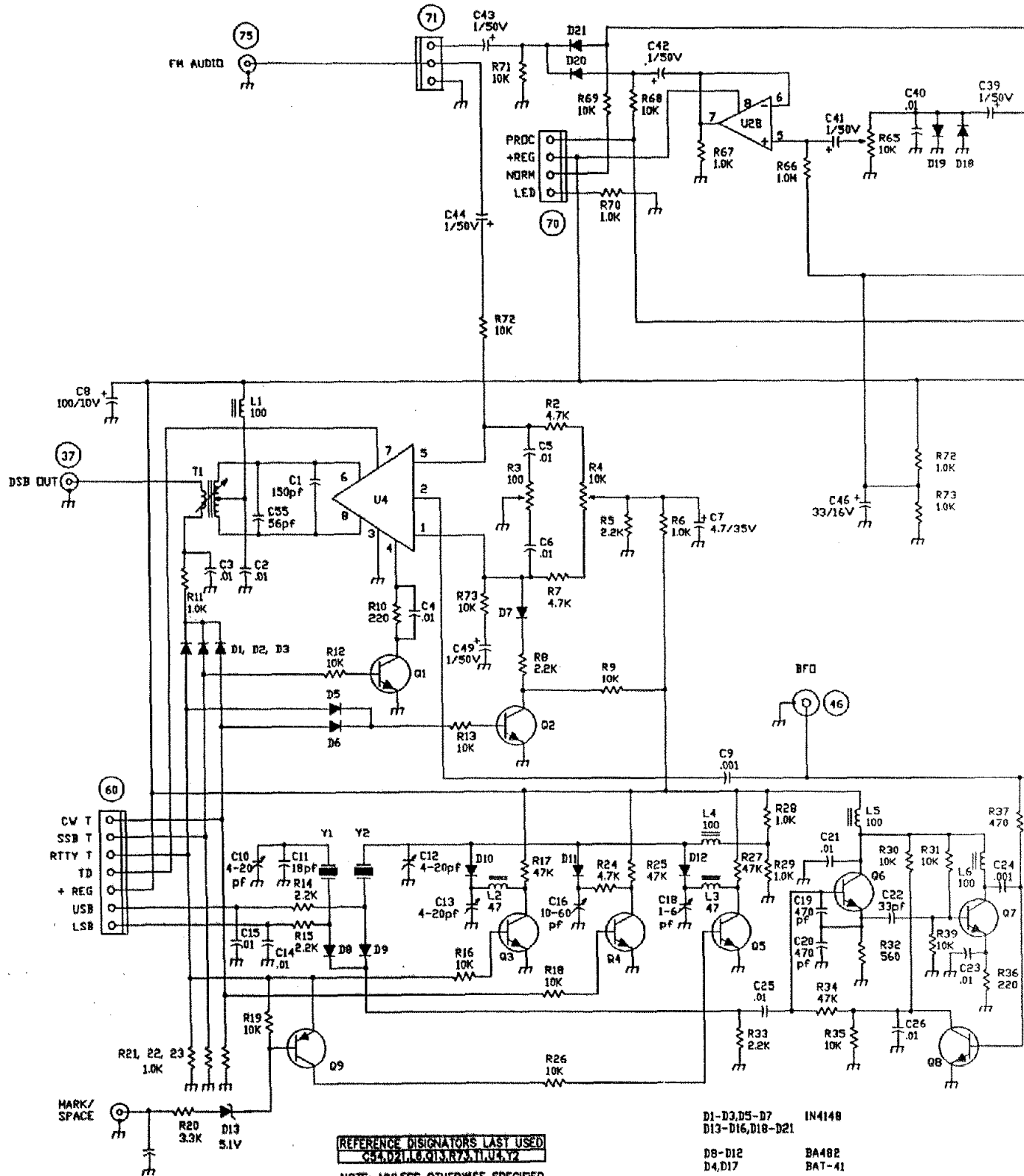

FIGURE 4-25. TX AUDIO BOARD COMPONENT LAYOUT (81597)



REFERENCE DESIGNATORS LAST USED
 C54, D21, L6, Q13, R73, Y1, U4, Y2

NOTE: UNLESS OTHERWISE SPECIFIED

- 1) CAPACITORS IN MICROFARADS (uF)
- 2) INDUCTORS IN MICROHENRYS (uH)
- 3) RESISTORS IN OHMS ±5% 1/4W

- D1-D3, D5-D7 IN4148
- D13-D16, D18-D21
- D8-D12 BA482
- D4, D17 BAT-41
- D1-Q5, D8, D10-Q13 MPS6314
- Q6 MPS5179
- Q7 2N4124
- Q9 2N5087
- U1-U3 LM358N
- U4 CA3053C

Part No. 74229
 4th Printing 2/94
 Printed in U.S.A.

FIGURE 4-26. TX AUDIO BOARD SCHEMATIC

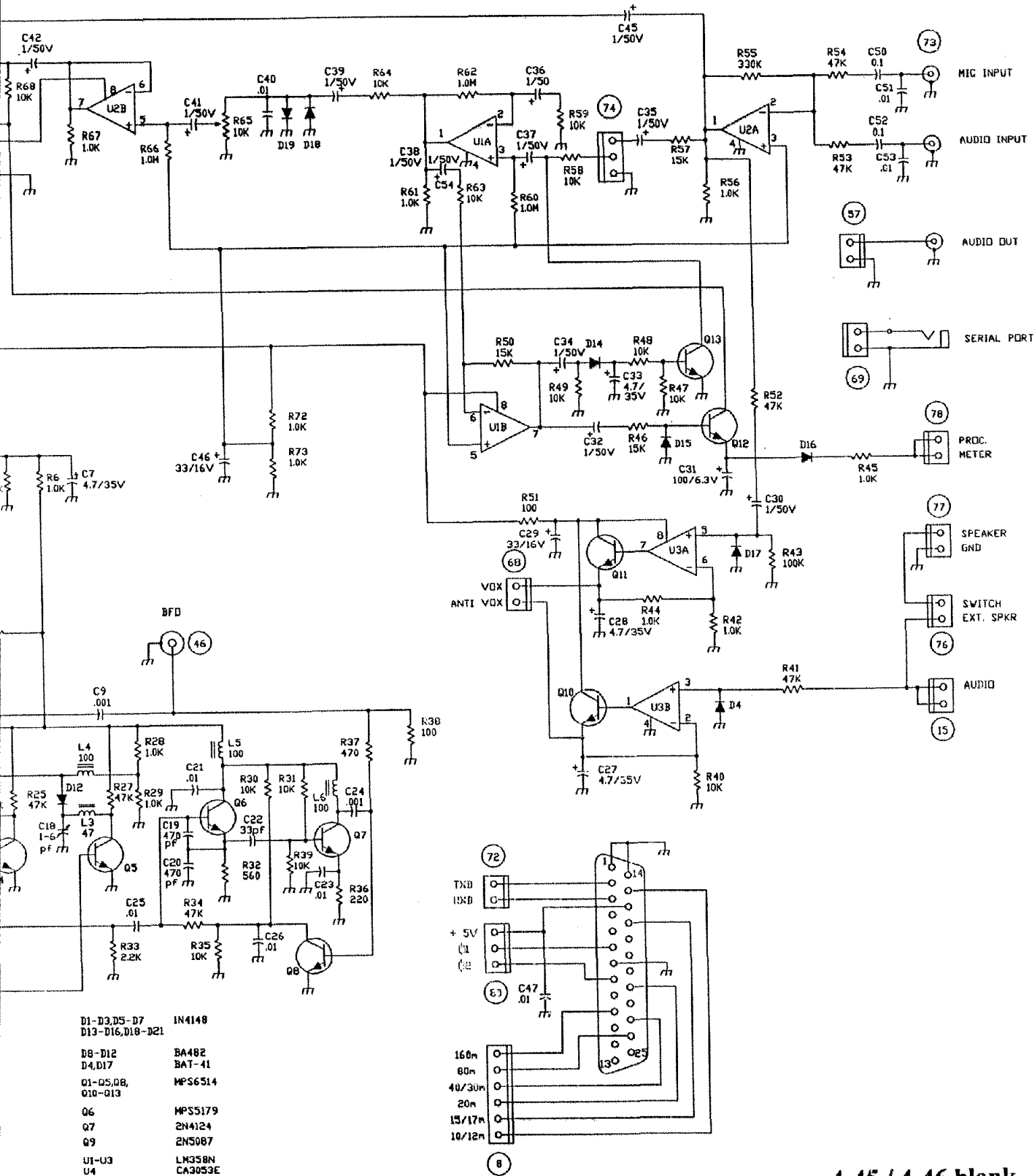

6. TX AUDIO BOARD SCHEMATIC (81597)

4-15 LOW LEVEL DRIVER / N.B. BOARD (81608)

This module contains the low level wide band amplifier for the transmitter, the receiver noise blanker, "T" and "R" voltage generator, and the "+REG" and meter lamp regulators. It is located on the left upper chassis on top of the PLL shield.

The operating frequency transmit signal from the BPF/Front End board enters on connector 24, is amplified by class A amplifier transistors Q9 and Q10, and exits to the Final Power Amplifier at connector 79. During transmit, "T" voltage supplies bias to both stages through R18 and R21.

"T" and "R" voltages are developed by Q1-Q8 based on the level of the "TD" pin from Control board connector 62. In transmit "TD" is high and Q5 sources approximately 12.5 Volts to the "T" line through R7, while Q7 holds the "R" line low. In receive "TD" is low and Q8 sources approximately 8.5 Volts to the "R" line through R13, while Q4 holds the "T" line low.

At connector 31, a sample of the 9 MHz receive IF signal from the 9 MHz Mixer/IF board is input to noise blanker amplifiers U1 and U2. The output of U2 is split two ways. Part of the signal is fed through C31 to Q13 which provides AGC control of U2. This helps to maintain a constant output level from U2 when there is no noise present or when the noise pulse widths are long. The N.B. pot., located on the Upper Pot. board, controls the emitter voltage of Q11 through connector 67. The

output of Q11 is summed with the AGC voltage from Q12 and sets the noise threshold of the noise blanker system. The other output of U2 goes to pulse amplifiers Q14 and Q15 whose output appears at connector 32. This output signal consists of noise pulse components with fast rise and fall times, which are applied to a noise gate circuit on the 9 MHz Mixer/IF board to blank the receiver during the noise pulse interval.

A regulator composed of U1 and Q19 supplies +8.5 Volts "+REG" voltage to all boards via connector 62 and the Control board. Q11 is mounted on the PLL shield plate and connected with cable Q.

Meter lamp control transistor Q18 is likewise mounted to the PLL shield and connected with cable P. Digit driving pulses are applied to connector 89 from the LED Display Driver board. These pulses are amplified and buffered by U3B, integrated by capacitor C18 and applied to regulator control amplifier U3A. Output of U3A drives Q18 whose output goes to the meter lamps via connector O. The duty cycle of the pulses at connector 89 can be varied under software control using the DIM function on the front panel keypad. As this pulse width is varied from minimum to maximum, the meter lamp voltage varies from about +2.7 volts up to a maximum of about +5.7 Volts.

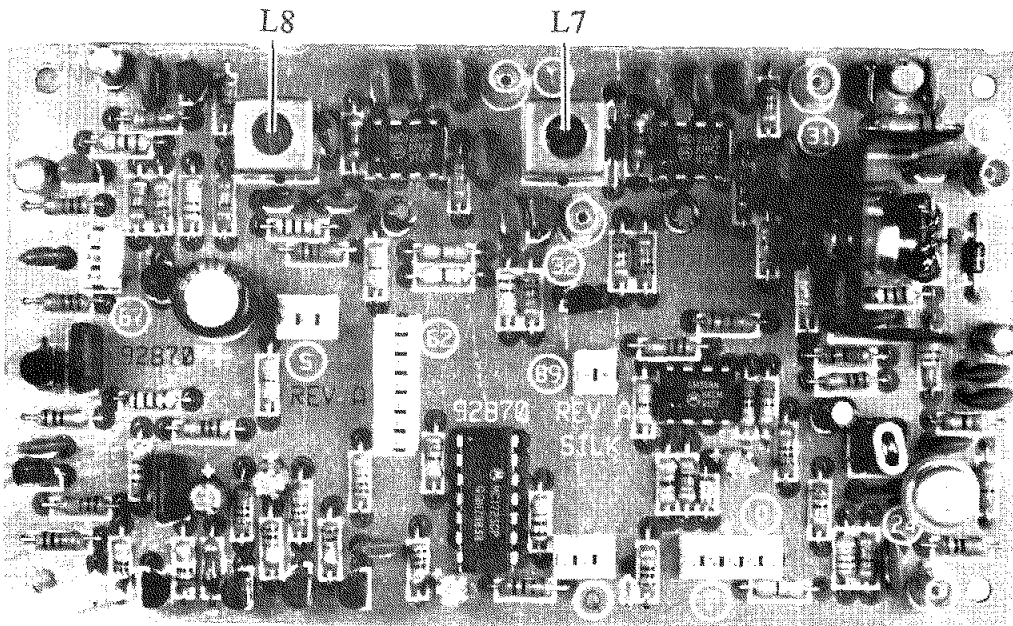
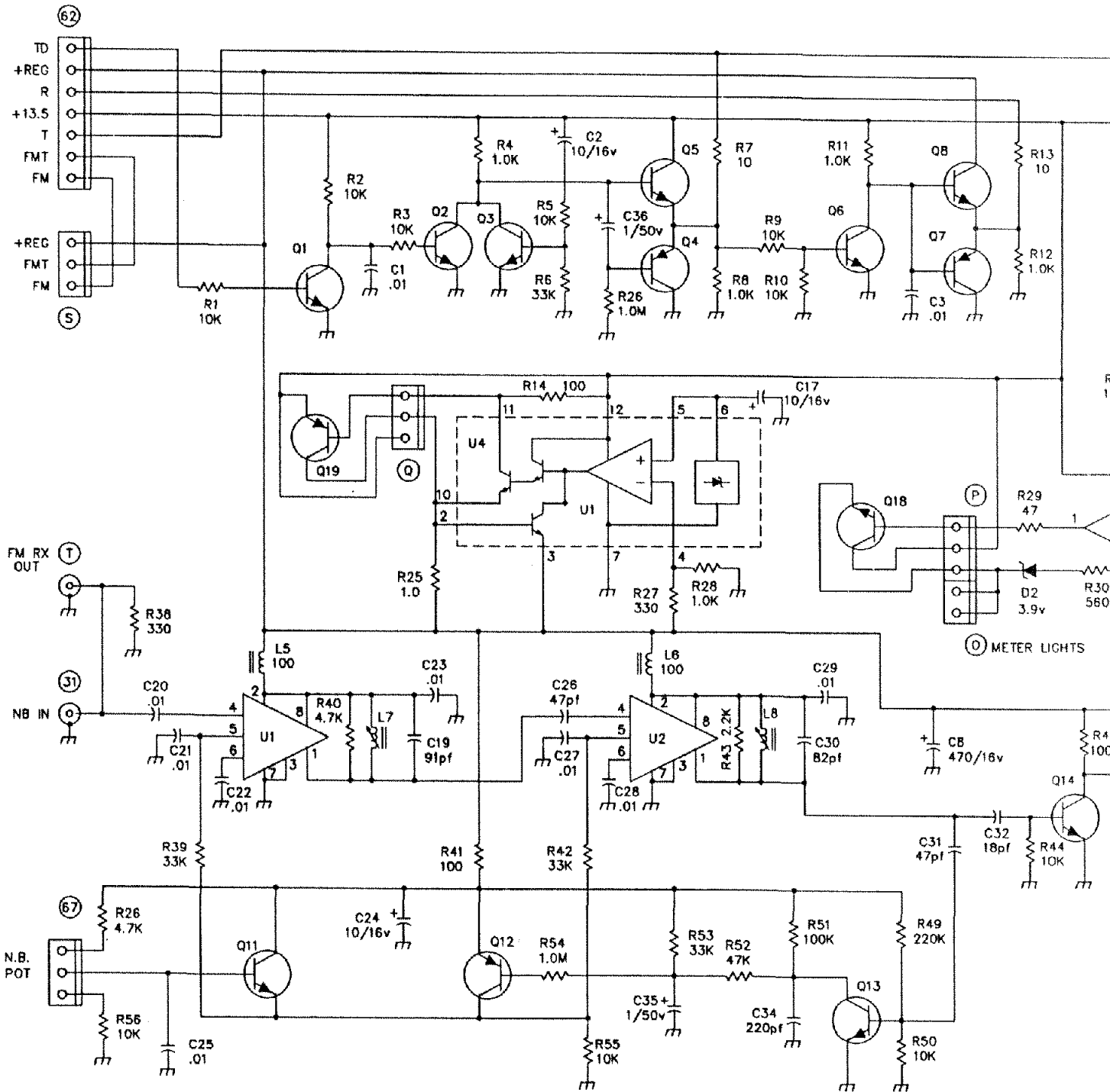

FIG. 4-27. L. L. DRIVER / N.B. BD. COMPONENT LAYOUT (81608)



REFERENCE DESIGNATORS LAST USED
 C36, D2, L6, Q19, R56, T2, U4

NOTE: UNLESS OTHERWISE SPECIFIED
 1) CAPACITORS IN MICROFARADS (uF)
 2) INDUCTORS IN MICROHENRYS (uH)
 3) RESISTORS IN OHMS ±5% 1/4W

U1-U2	MC1350	Q4, Q7
U3	LM358	Q11, Q13, Q19
U4	MC1723P	Q12, Q15
D1	1N4002	Q13, Q17
D2	1N748A	Q9
Q1-Q3	MPS6514	Q10
Q6	MPS6514	Q18
Q5, Q8	MPSU01	Q19

FIGURE 4-28. LOW LEVEL DRIVER / N.B. BOARD

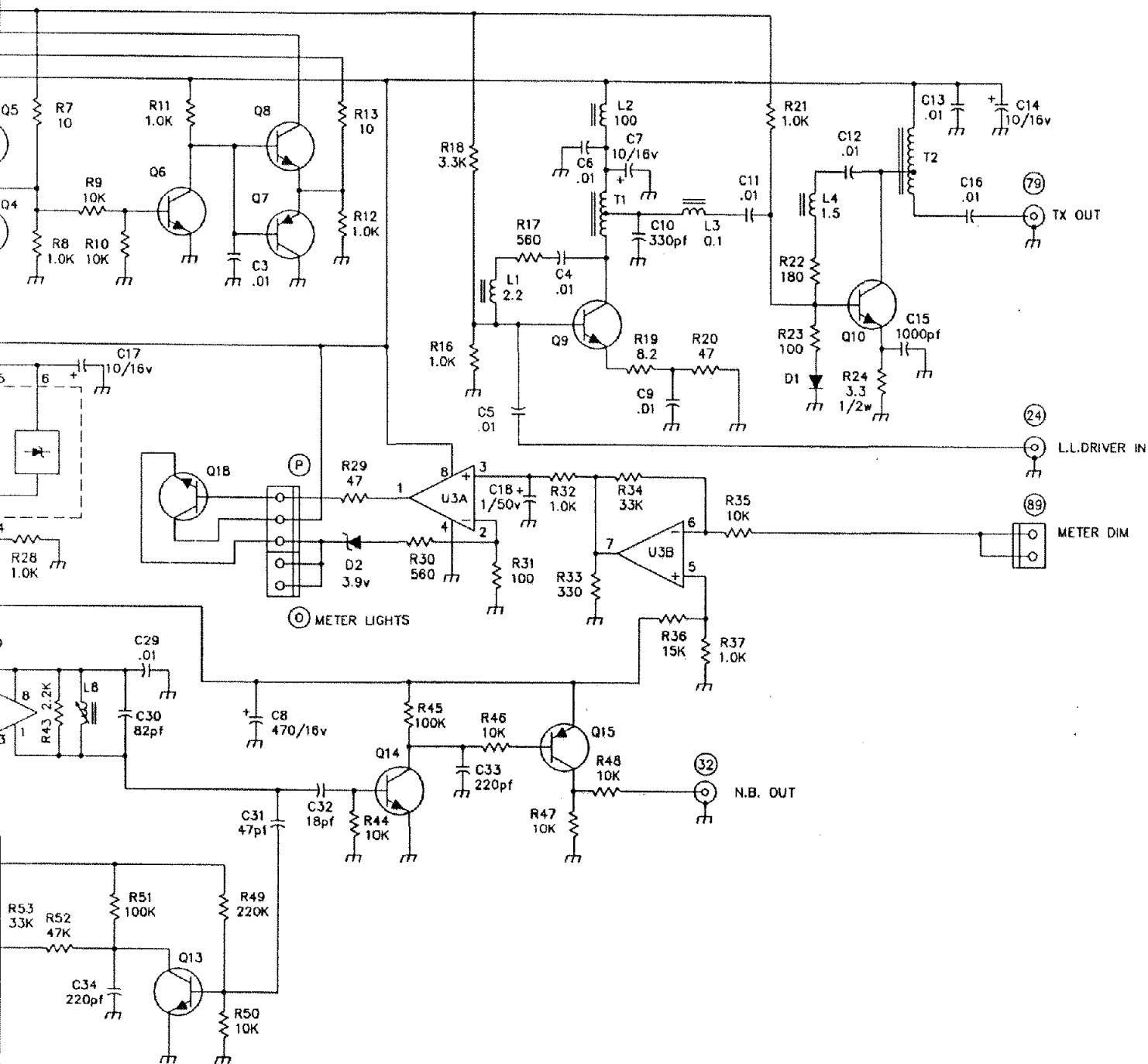

USED

IFIED
S (uF)
(uH)
4W

U1-U2	MC1350	Q4, Q7	2N5087
U3	LM358	Q11, Q13, Q14	MPS6514
U4	MC1723P	Q12, Q15	2N5087
D1	1N4002	Q13, Q17	2N5087
D2	1N748A	Q9	2N3866
Q1-Q3	MPS6514	Q10	2SC1969
Q6	MPS6514	Q18	MJE520
Q5, Q8	MPSU01	Q19	MJE370

LOW LEVEL DRIVER / N.B. BOARD SCHEMATIC (81608)

4-16 POWER AMPLIFIER (81611)

The high power RF amplifier, its push-pull driver stage, and the PA bias circuits are housed in a metal box which is an integral part of the heatsink assembly. The unit is attached to the rear panel with four hex head screws. Input is received through connector 79 on the Low Level Driver board, and the 100 Watt output is through a miniature coaxial cable soldered to pins on the Low Pass Filter board. "T" voltage enters the unit on the small blue wire from connector 11 on the Low Pass Filter board, and +13.5 Volts dc enters on the large red wire from the DC Input board.

Q1 and Q2 form a wideband class AB linear driver stage with input and output impedance matching accomplished by broadband transformers T1 and T3. RC networks R1-C1 and R5-C2, in conjunction with feedback networks R3-L3-C4, R6-L4-C5, control the input impedance and flatten the gain variation of the transistors over the frequency range of 1.6 - 30 MHz. Regulated bias is fed to this stage from Q5-U1A.

Q3 and Q4 form the high power broadband output stage of the transmitter. This stage is also biased to linear class AB operation by regulator circuit Q6-U1B. Input impedance and gain variation with frequency are controlled by RC input networks and RF feedback similar to the driver stage. Broadband transformer T4 matches the output stage to 50 ohms for driving the transmit low pass filters.

Bias for both stages is temperature compen-

sated to maintain a relatively constant operating point by mounting the bias reference diodes D2 and D3 in thermal contact to the heatsink. The temperature dependent voltage across each reference diode is added to a portion of the "T" voltage and the sum is used as a reference voltage for the respective bias regulator U1A-Q5 or U1B-Q6 in the PA bias circuit. In receive, "T" voltage is low and both regulators are cut off, removing bias from both PA stages. When "T" goes high, capacitor C25 delays the rise of the bias reference voltages, reducing the gain of the PA until the rest of the transceiver settles into a stable transmit mode.

The bias adjustment potentiometers R19 and R15 are accessible through the bottom shield of the transceiver. To adjust PA bias, a dc amp meter must be inserted in series with the large red +13.5 Vdc lead coming from the DC Input board. Unplug connector 79 from the Low Level Driver/N.B. board to remove drive from the PA. Key the transmitter in USB mode. While watching the meter, rotate first the final bias pot. R15 and then the driver bias pot. R19 to produce minimum current. Now rotate the driver bias pot. R19 to increase the meter reading by 50 milliamperes. Next rotate the final bias pot. R15 to produce an additional increase of 500 milliamperes on the meter. Remove the meter and reconnect the red wire to the DC Input board and connector 79 to the Low Level Driver/N.B. board.

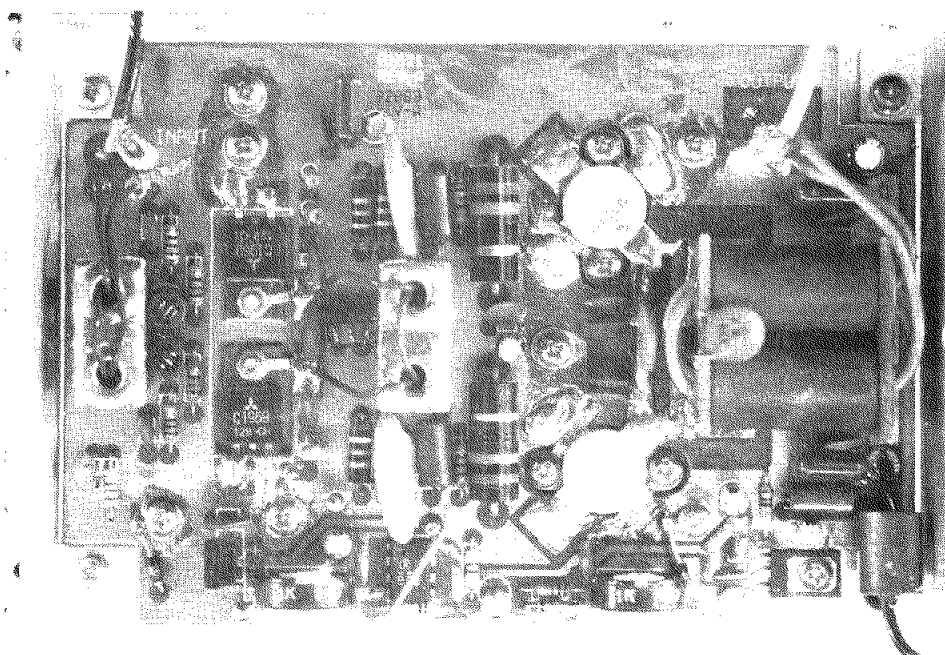

FIGURE 4-29. POWER AMPLIFIER COMPONENT LAYOUT (81611)

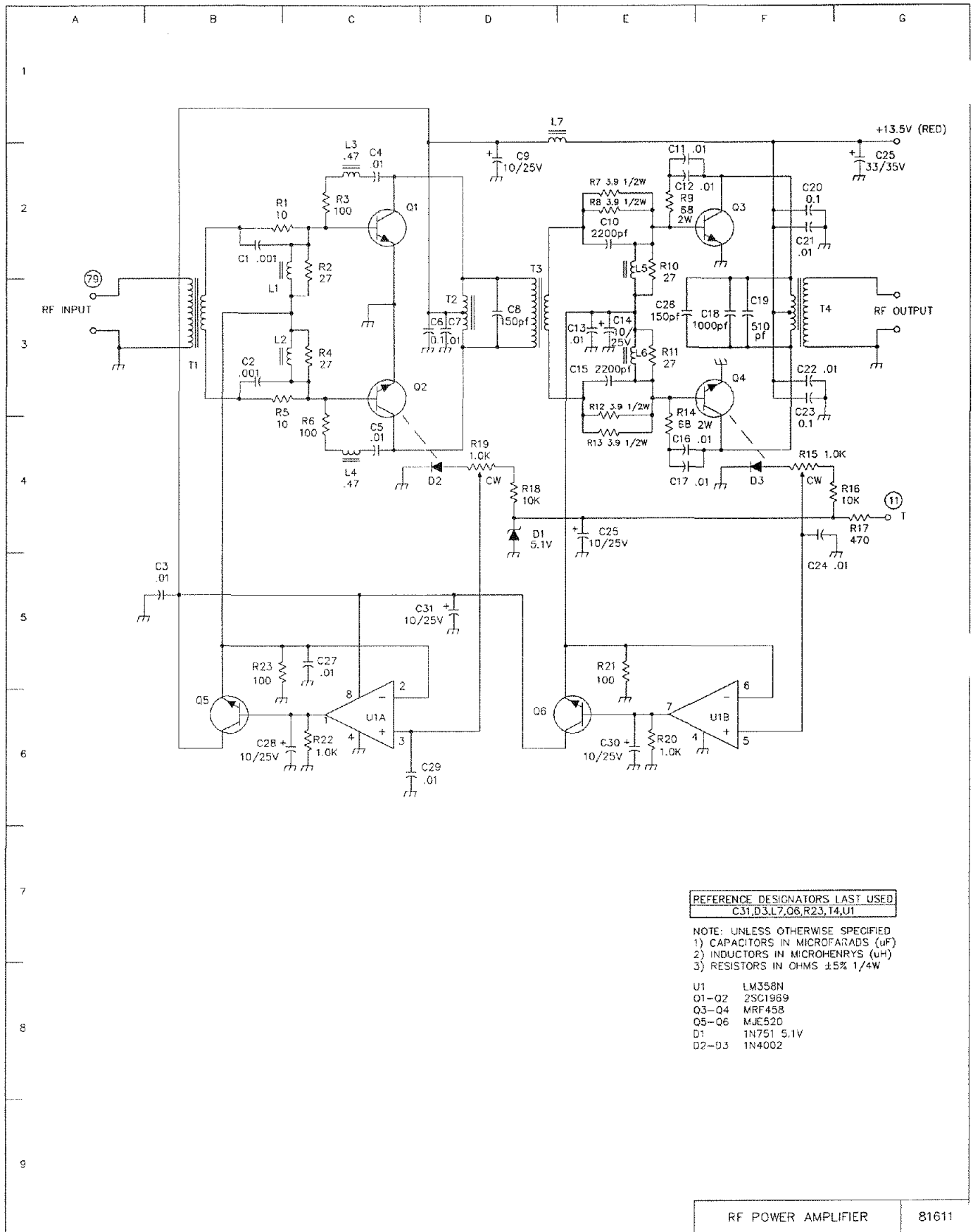

FIGURE 4-30. POWER AMPLIFIER SCHEMATIC (81611)

4-17 FM BOARD (81598)

This module contains circuitry for two separate signal paths.

On transmit, connector 75 receives an amplified microphone signal from the TX Audio/BFO board. Amplifier U2A provides preemphasis with a high pass response of typically +6 dB/octave over the 300 to 3000 Hz audio range. Diodes D4 and D5 limit the peak-to-peak amplitude of the processed audio to prevent over deviation of the FM carrier. Low pass filter U2B filters harmonic distortion from the limiter and adjusts the amplitude of the audio for varactor D6. The varactor performs the voltage to frequency conversion in the Colpitts oscillator Q2. L2 is adjusted to center the oscillator at 9.003 MHz with no audio bias. Buffer transistor Q3 isolates the oscillator and provides about -5 dBm carrier to the next transmitter stage on the 9 MHz Mixer/IF board via connector 33. At this point the transmitter treats the FM carrier as if it were CW.

In receive, the FM receive signal is tapped off the 9 MHz IF of the noise blanker circuit on the Low Level Driver/N.B. board and enters the FM board at connector T. The signal feeds U1, an MC3371P FM receiver chip, which converts down to a 455 kHz IF frequency.

Ceramic filter FL1 sets the receive bandwidth for the on-chip quadrature detector. T1, the quadrature coil, is adjusted for maximum recovered audio and minimum distortion. The audio signal is deemphasized by the low pass network of R6, C5, and C6 and is carried on to the IF/AF board through connector U. The wideband audio signal is also fed through R5-C4, to pin 10 of U1, which contains an internal opamp used as a noise triggered squelch. Output of the internal opamp at pin 11 is routed through C2 to D1 and through connector R to the front panel mounted SQUELCH control. When the amplitude of the audio is below the level set by the squelch control diode D1 conducts and pulls pin 12 low, allowing U1 to mute the audio output.

U1 also provides an S-meter output control current at pin 13. This current is proportional to the logarithm of the IF input signal amplitude, and is fed to buffer transistor Q1. Diode D2 is used to compensate for the base-emitter voltage drop of Q1, and potentiometer R8 is used to calibrate the S-meter reading. S-meter output from Q1 is sent through connector V to the front panel meter switch.

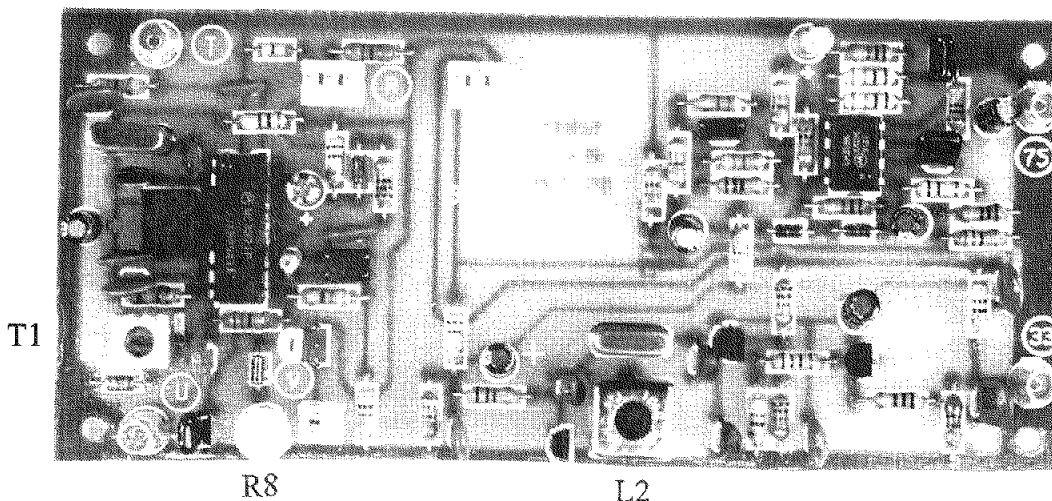

FIGURE 4-31. FM BOARD COMPONENT LAYOUT (81598)

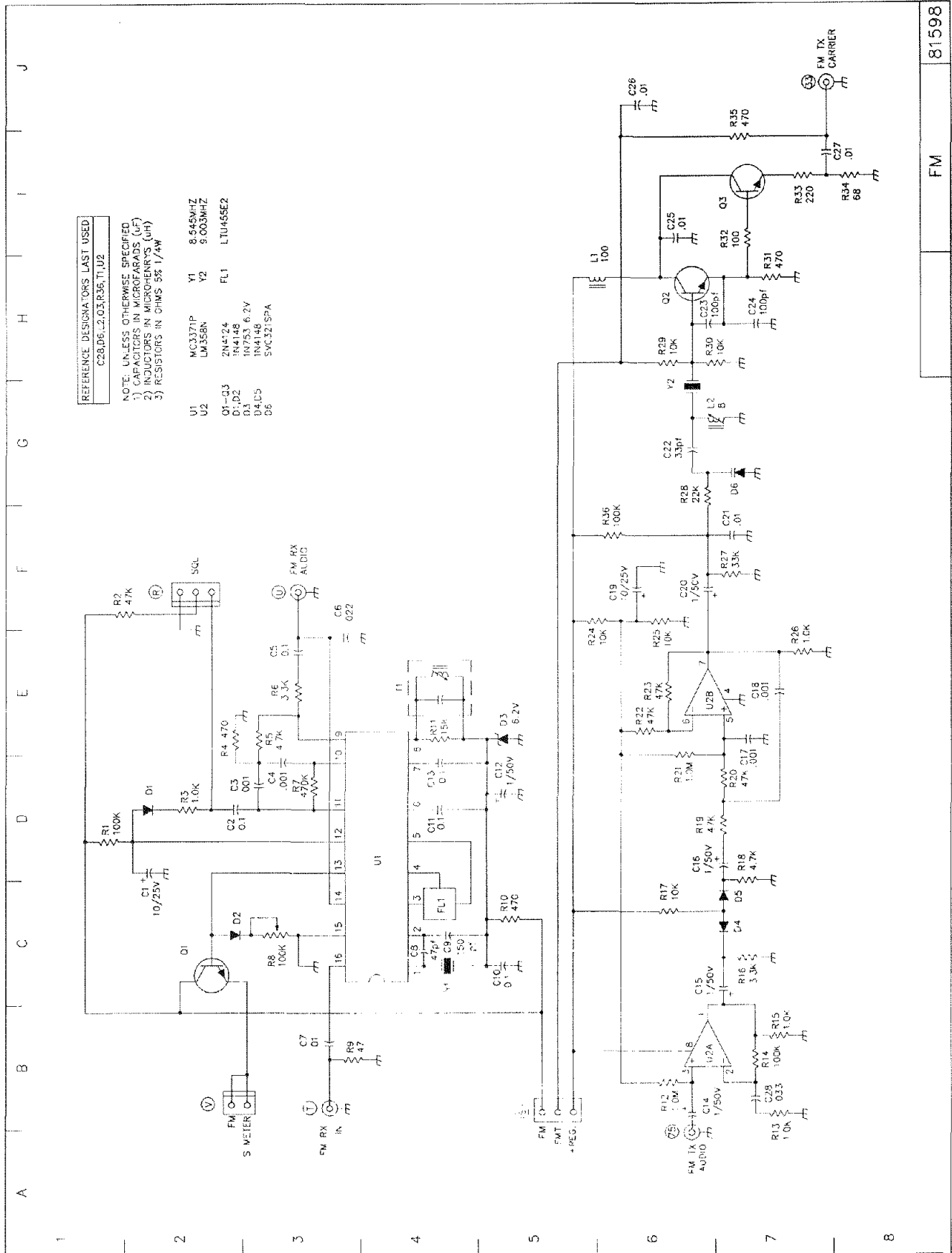

FIGURE 4-32. FM BOARD SCHEMATIC (81598)

4-18 KEYPAD / ENCODER BOARD (81589)

This module contains an array of 44 key switches, 18 LED indicators and a rotary shaft encoder. The circuit board is mounted to the rear of the front panel keypad bezel and is connected to the Logic board through seven connectors which are accessible through the sub panel at the rear of the fold down front panel assembly.

The keypad switches are arranged electrically in an array of eleven columns and four rows. The columns are scanned through connectors 92 and 93, and the rows are read through connector 91. The microprocessor detects a key closure by strobing each column line low in sequence, while watching for a low to appear on any of the row lines. The location

of the closure is defined by the intersection of the column and row lines that are simultaneously low.

The Logic board drives the indicator LEDs through connectors 94, 95 and 96. The LEDs are illuminated by a positive drive voltage and all cathodes are returned to ground through connectors 95 and 96.

A separate reset switch, S1, is located just to the right of the FM key and is accessible through a small hole in the front bezel. This switch is connected to the Logic board through connector 97 and is used to perform a master reset of the logic circuits and microprocessor located on the Logic board.

A rotary encoder is mounted to the keypad assembly and its output is routed to connector 98, located on the Logic board.

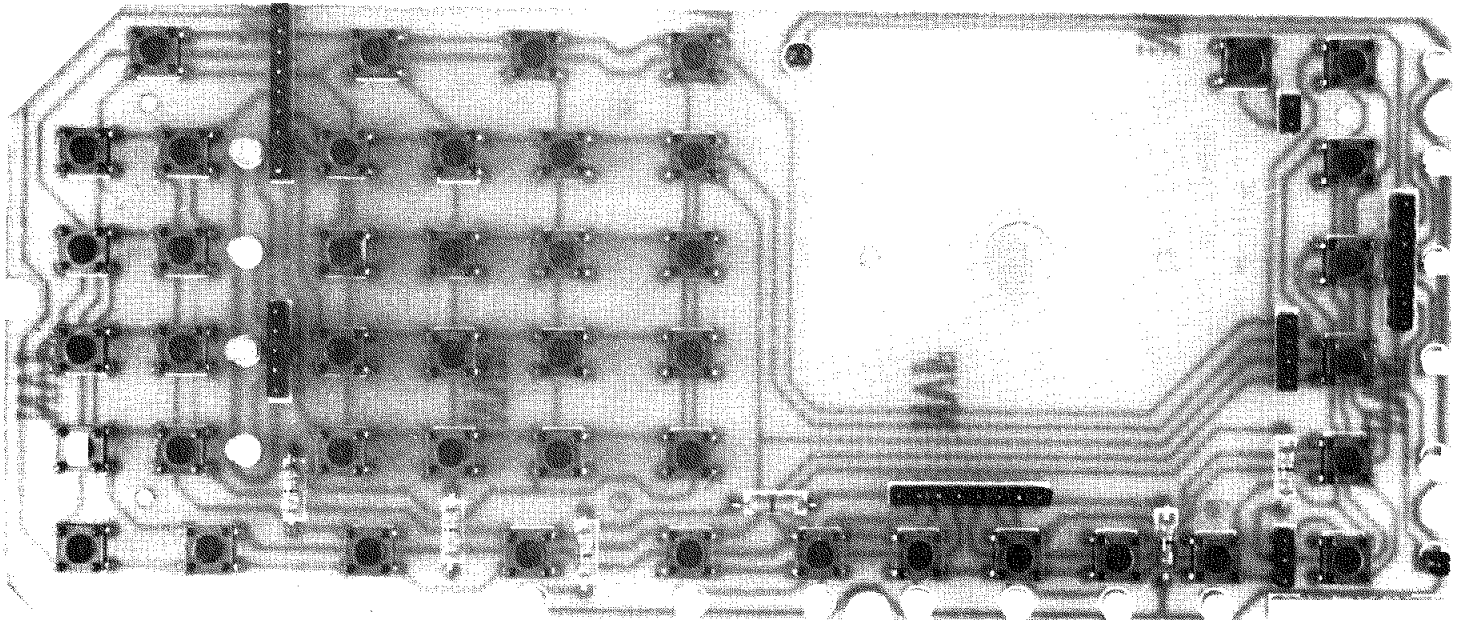

FIGURE 4-33. KEYPAD / ENCODER BD. COMPONENT LAYOUT (81589)

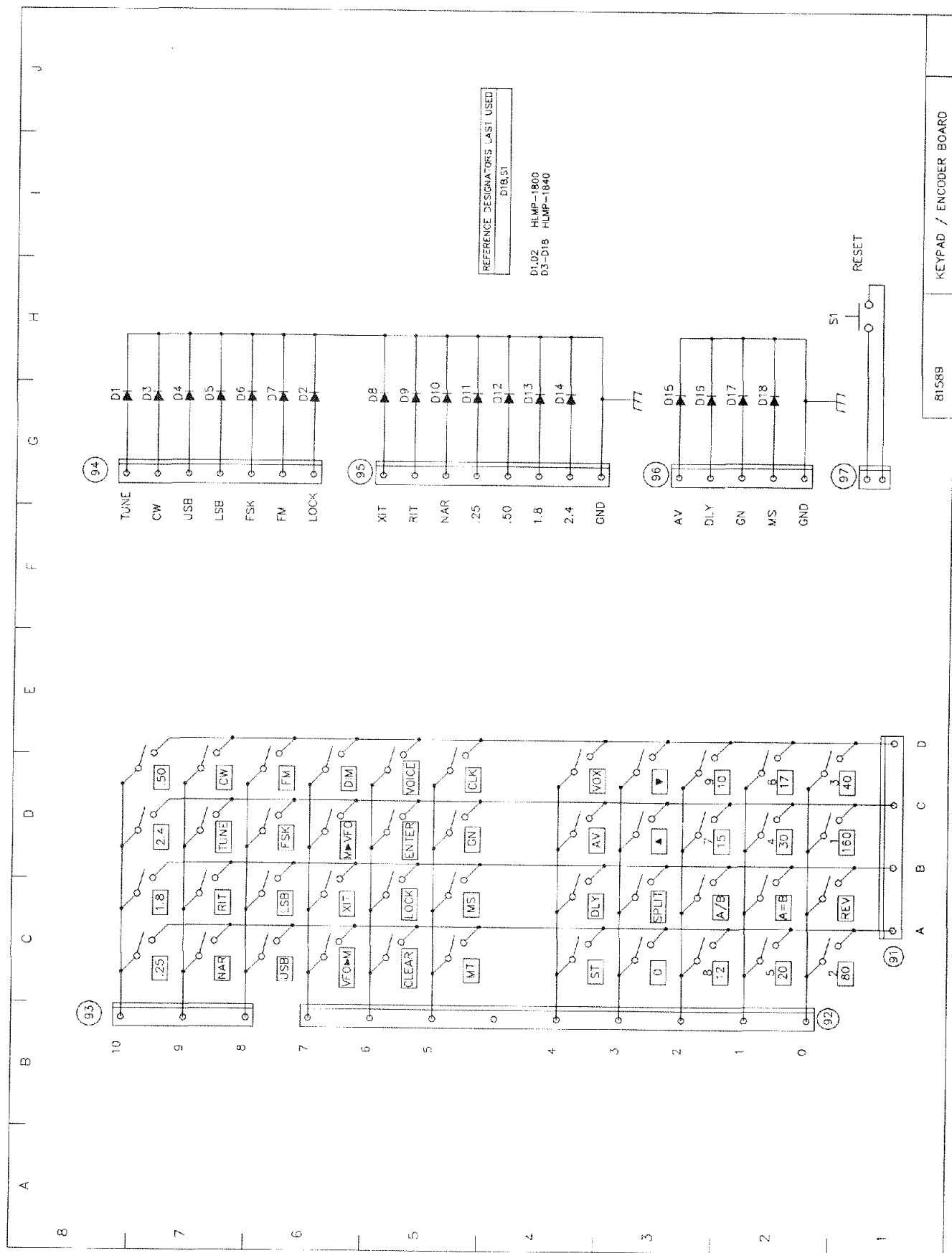

FIGURE 4-34. KEYPAD / ENCODER BOARD SCHEMATIC (81589)

4-19 SWITCH BOARD (81603)

This module contains two LED indicators and five latching pushbutton switches which control the functions of ANTENNA main/aux, AGC on/off, AGC fast/slow, NOTCH auto/manual, and QSK fast/slow. This assembly is mounted on the left front subpanel just inboard of the main POWER switch.

Switch S1 is connected to the Low Pass Filter board by connector 7 and selects either the main or auxiliary antenna for use during receive. LED D1 is turned on when S1 is set to the AUX position.

AGC on/off switch S2 disables the AGC circuit on the IF/AF board by grounding the AGC amplifier input through connector 49.

AGC fast/slow switch S3 increases the

AGC decay time in the slow position by grounding the bottom end of an additional integrating capacitor in the AGC circuit.

NOTCH auto/manual switch S4 connects to the Logic board through connector 48. When in the AUTO position LED D2 is turned on and the automatic notch function, implemented in the DSP processing circuits, is enabled along with the front panel manual notch control. When in the MANUAL position only the front panel manual notch control is active.

QSK fast/slow switch S5 also connects to the Logic board through connector 48. The setting of this switch is monitored by the microprocessor which adjusts the software controlled keying accordingly.

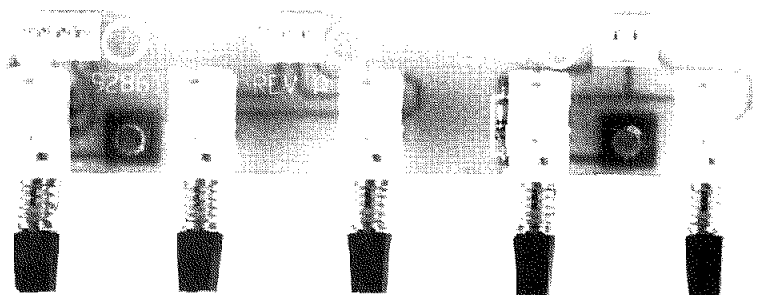

FIGURE 4-35. SWITCH BOARD COMPONENT LAYOUT (81603)

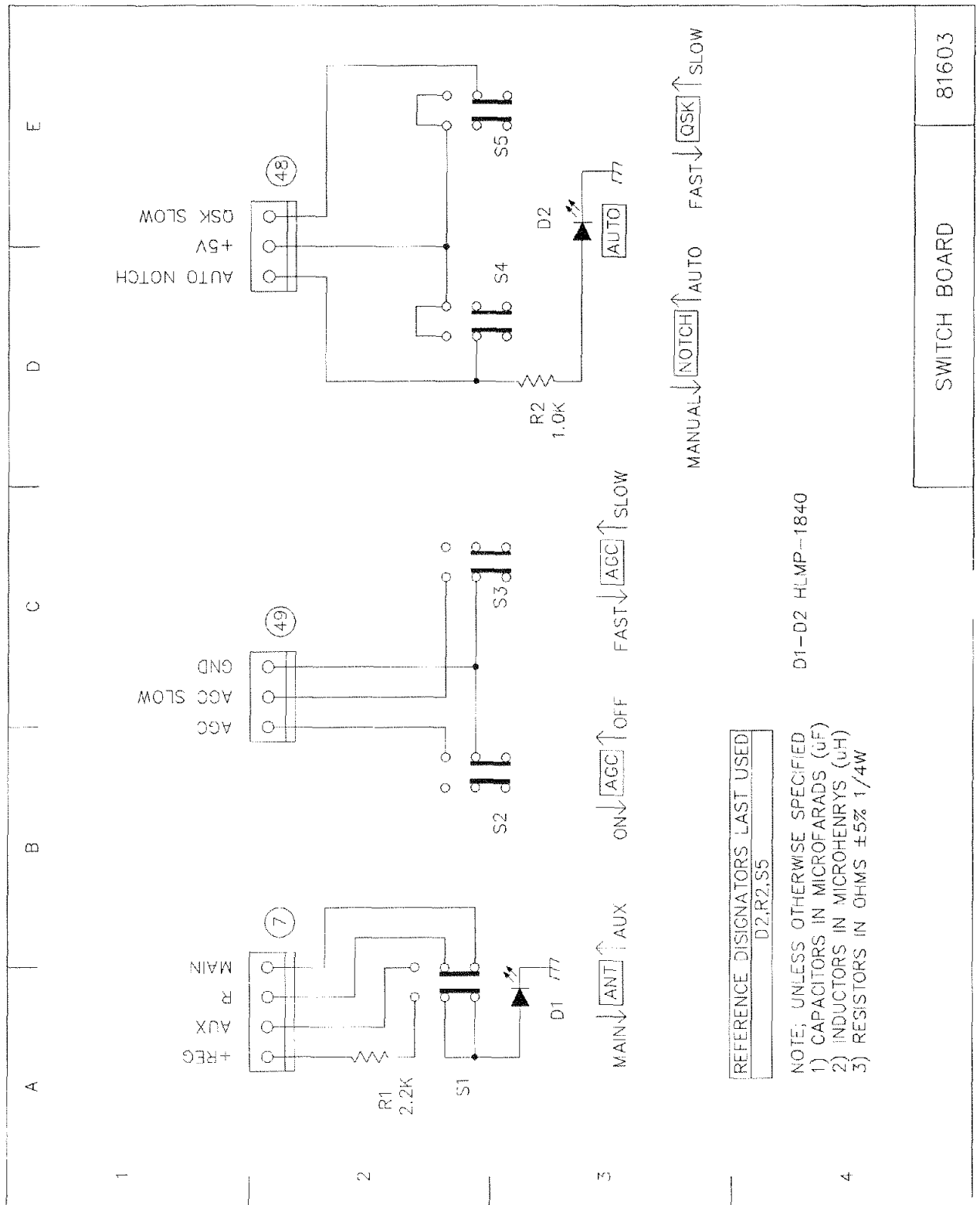

FIGURE 4-36. SWITCH BOARD SCHEMATIC (81603)

4-20 UPPER POT. BOARD (81604)

This module contains two dual concentric controls, a latching pushbutton switch and an LED indicator. The board mounts on the left front sub panel at the control positions of N.B. and SQL, PBT and NOTCH, and the ATTN switch.

The ATTN switch S1 is wired to the BPF/Front End board by connector 18 where it controls the insertion of the receiver attenuator pad. When the pad is inserted, S1 applies +13.5 Volts to the anode of -20dB indicator LED D1 and also to the attenuator switching circuit on the BPF/Front End board.

The N.B. control R1A connects to the Low Level Driver/N.B. board through connector 67. This control adjusts the input threshold

level of the noise blanker amplifier.

The SQL control R1B is connected to the FM board through connector R, and adjusts the squelch noise threshold of the FM receiver chip.

NOTCH control R2B, through connector 53 to the IF/AF board, varies a dc voltage to a clock oscillator which determines the frequency of the manual audio notch filter. Clockwise rotation of R2B increases the voltage at the wiper, increasing the notch frequency.

The PBT control R2A connects to the Pass Band Tuning board through connector 42, where it controls the dc bias to the 15.3 MHz pass band tuning VCXO. Clockwise rotation of R2A increases the voltage on the wiper, increasing the frequency of the VCXO.

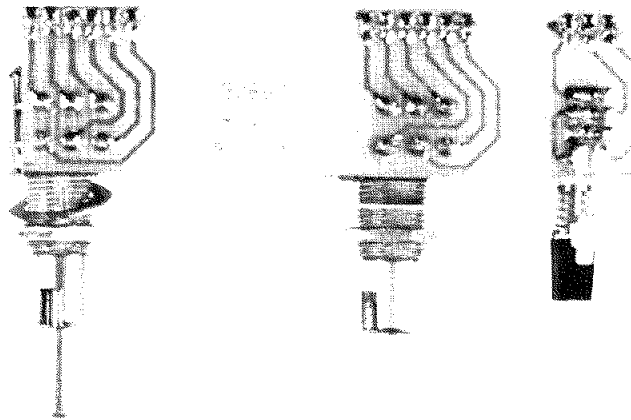

FIGURE 4-37. UPPER POT. BOARD COMPONENT LAYOUT (81604)

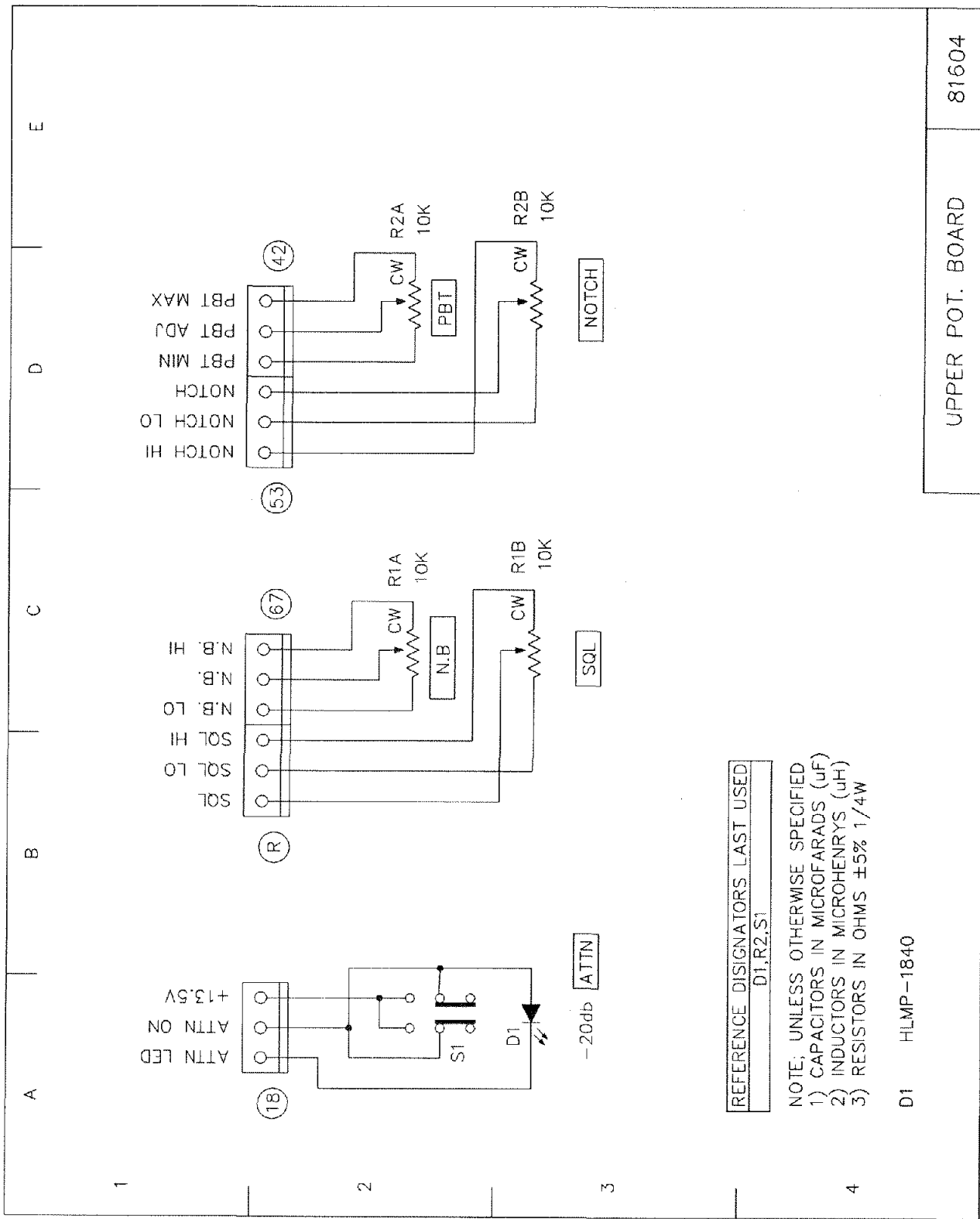

FIGURE 4-38. UPPER POT. BOARD SCHEMATIC (81604)

4-21 LOWER POT. BOARD (81605)

This module contains two dual concentric controls, a latching pushbutton switch, and two LED indicators. The board mounts on the left front panel at the control positions of MIC and PWR, AF and RF, ALC indicator, and the PROC on/off switch and indicator.

When PROCessor on/off switch S1 is in the "on" position, "+REG" voltage is applied to the anode of LED D1 and, through connector 70, to a diode on the TX Audio board which routes processed audio to MIC gain control R1A via cable 71. R1A sets the level of the signal returning on cable 71 to the balanced

modulator. When S1 is in the "off" position, indicator D1 is extinguished, and unprocessed transmit audio is routed through R1A to the balanced modulator.

PWR control R1B forms a voltage divider, through connector 29 to the 9 MHz Mixer/IF board, which sets the ALC threshold. ALC action develops a current through connector 28 which illuminates ALC indicator D2.

AF gain and RF gain controls, R2A and R2B, form voltage dividers, through connectors 55 and 50 to the IF/AF board, which determine respectively audio output level and AGC resting voltage.

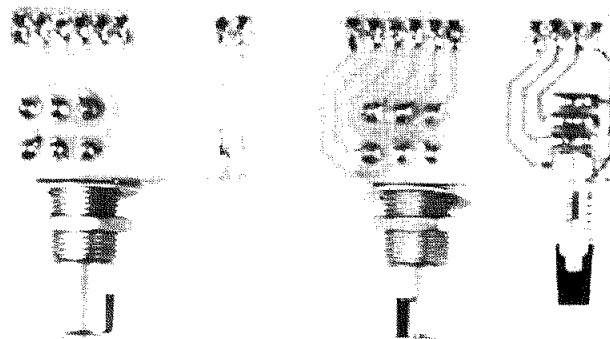

FIGURE 4-39. LOWER POT. BOARD COMPONENT LAYOUT (81605)

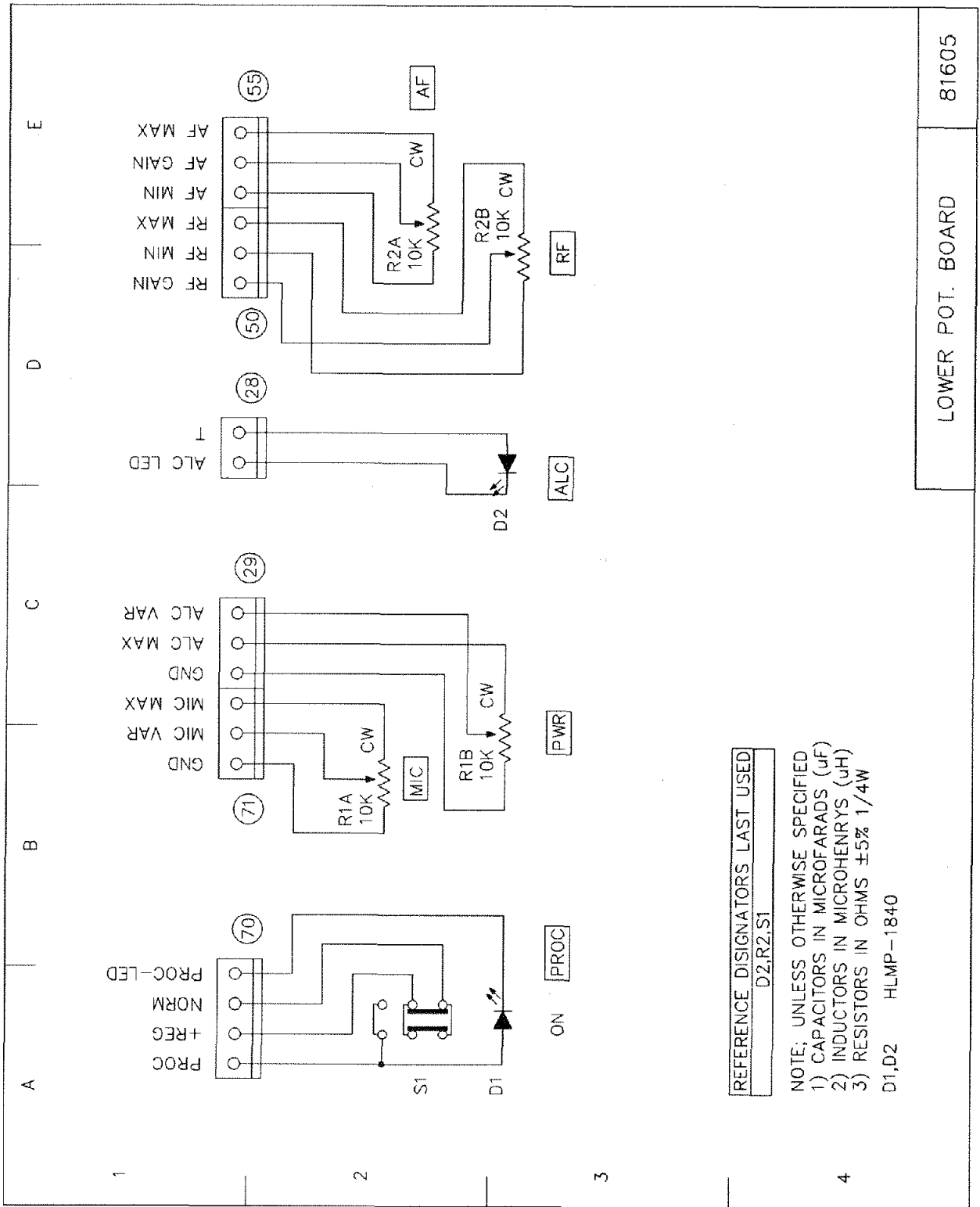
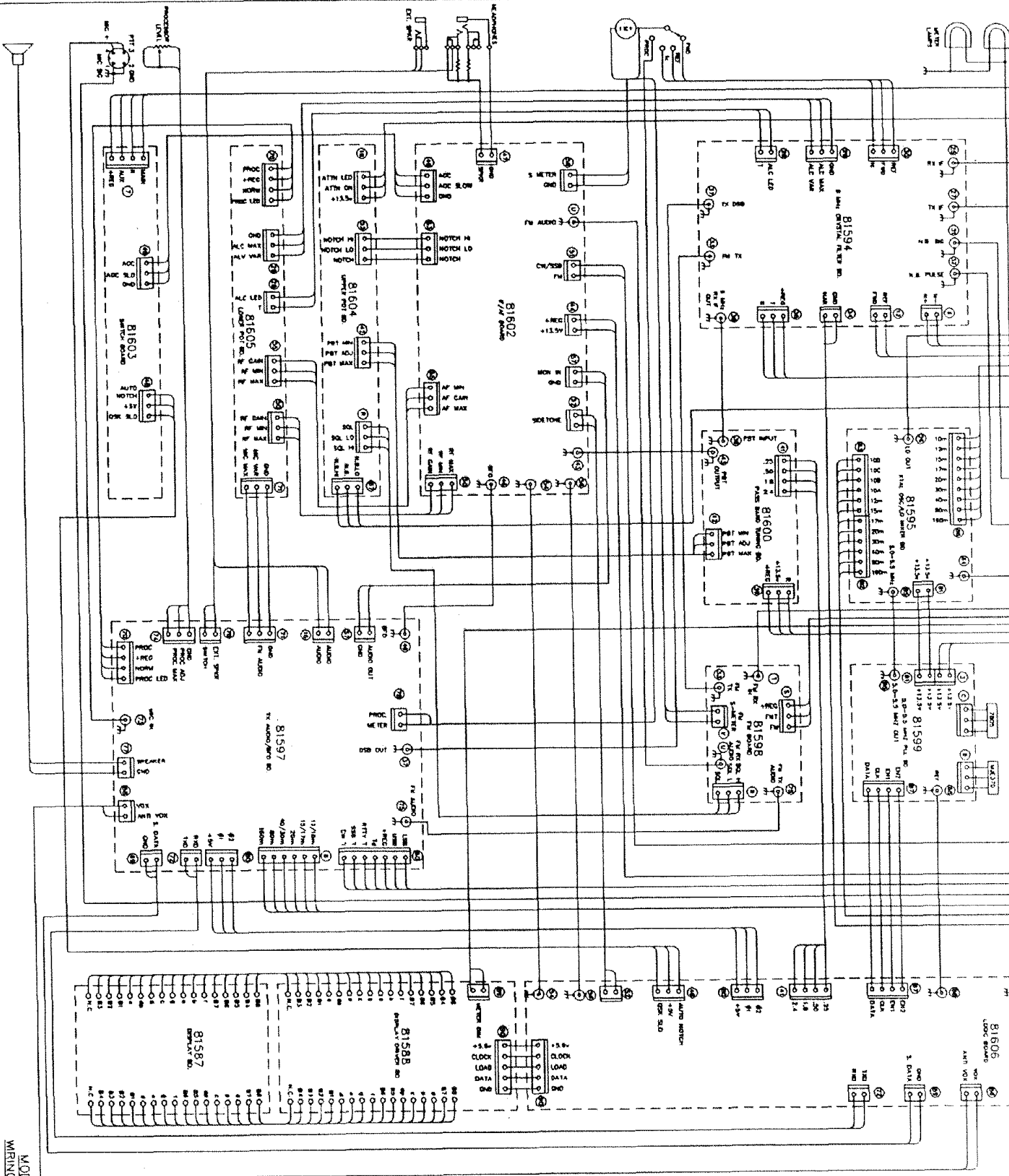

FIGURE 4-40. LOWER POT. BOARD SCHEMATIC (81605)



MODEL 563
WIRING DIAGRAM

CHAPTER 5 OMNI VI SERIAL INTERFACE

5.1 INTRODUCTION

The OMNI VI transceiver contains a comprehensive computer control interface. Remote control of many transceiver functions provide additional operator convenience and flexibility. The Serial Interface built into the OMNI VI was designed to be compatible with many existing contest and logging software packages. The OMNI VI factory settings allow it to emulate an ICOM 735 transceiver and your software should be configured to operate with the 735 until software vendors take advantage of the OMNI VI's extended command set.

For those that wish to write their own control program, the interface command structure and command set are included to help guide you through the process. FIGURE 5-1 shows how to connect your OMNI VI to a computer via the DB-25 connector. If this port is already in use, another serial port is available on the rear panel. The Model 305 serial level converter must be used when using this serial port with a computer.

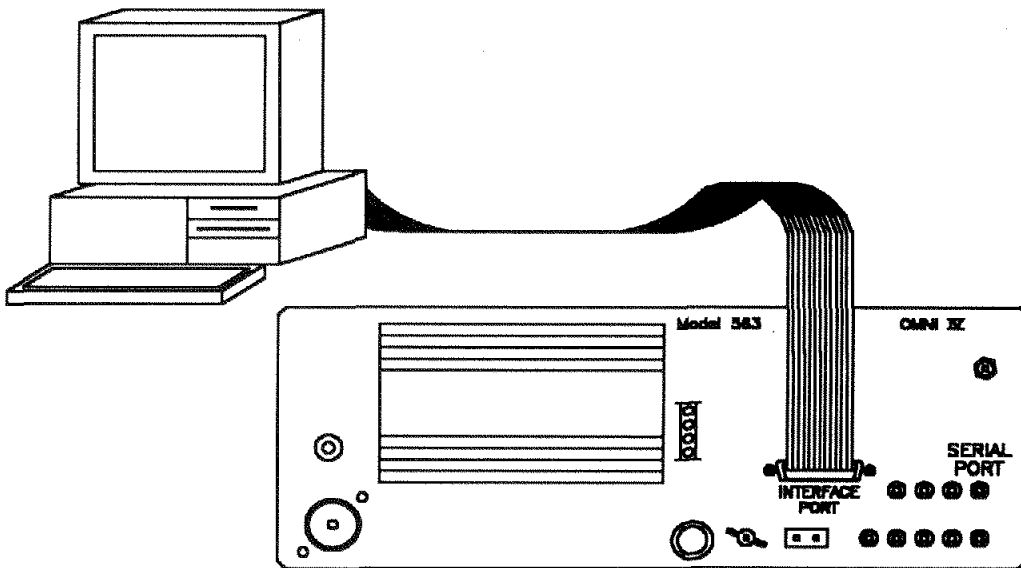

FIGURE 5-1 CONNECTION OF OMNI VI TO COMPUTER

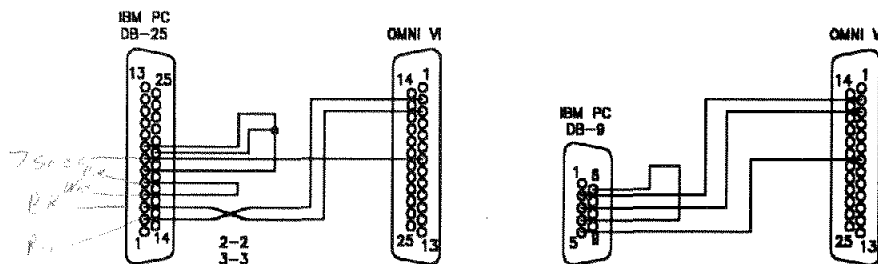

FIGURE 5-2 RS-232 CABLE WIRING CONNECTIONS

5.2 COMMAND/CONTROL OPERATIONS OF TEN-TEC TRANSCEIVERS

When connected to a personal computer, many transceiver operations can be controlled and/or queried remotely. Operating frequency, modes and memory selections can be controlled. There are many software packages available to control a transceiver while providing LOGGING and DATABASE features. Many of these programs are excellent and choosing one will be the quickest way to take advantage of remote transceiver operations.

The following information is supplied as reference if you choose to write your own transceiver control program since commands must be sent in a form that the transceiver will understand and can act upon. To communicate with a TEN-TEC Model 563, the personal computer must first be set-up properly. The computer's RS-232 port must be configured for the desired baud rate (1200, 2400, 4800, 9600, or 19200), NO parity, 8 data bits and 1 stop bit. Each transceiver has a unique identifier and in the TEN-TEC Model 563, this unique identifier may be set in the "User Options Menu". This identifier is a two digit number and the transceiver 'ADDRESS' as its called, must match the transceiver address in any software program.

5.3 COMMAND/DATA FORMATS - COMPUTER TO TRANSCEIVER

Commands and data traveling from a host computer to a transceiver or vice versa must be properly encoded if the interface is to operate properly. The commands and data are sent as strings of numbers and/or characters that represent specific operations to a transceiver. Generally, operation involves sending a command to the transceiver and then waiting for the transceiver to respond. Depending on the command, the transceiver may respond with a string of characters indicating 'OK', meaning that the requested command has been processed. Alternately, the transceiver may respond with a string of characters indicating 'NO GOOD' to the computer, meaning that the transceiver was unable to process the request. Some commands, may result in the transceiver returning some operational information from the radio such as current frequency or mode. If a transceiver responds with a NO GOOD code, it was either because the command was not in the proper format or because the requested operation was not available on that transceiver.

The structure of the commands and responses is designed to limit the amount of data to be sent or received via the serial interface. This allows the interface to operate quickly. The general format of a command is shown below (sent left to right). Notice, that numeric codes are encoded in Hexadecimal format.

FE	FE	RECEIVER ADDRESS	SENDER ADDRESS	COMMAND CODE	SUB COMMAND	DATA	FD
----	----	------------------	----------------	--------------	-------------	------	----

The FE FE at the beginning of the string is the two byte code that tells the transceiver a command is to follow. The transceiver will prepare itself to check the command to determine if it contains its address, which tells the transceiver that it is to process the command that will follow. If the RECEIVER address in the command string, does not match the transceiver's address, the command is ignored by the transceiver. (There are a few exceptions to this rule to be discussed later). The SENDER address is a code that represents the address of the computer that is sending the command. This address will be used later by the transceiver when it responds to the command request. Because the serial interface allows multiple computers to be used as well as multiple transceivers, each computer must have a unique address just as each transceiver is required to have a unique address. The default computer address used most is E0 Hex. The COMMAND CODE tells the transceiver which operation to perform. All command codes are in Hexadecimal format. Some commands contain additional Sub Commands that further clarify to the transceiver the specific operation that is to be performed. Specific codes may be found in the following pages.

The DATA portion of the command string is required by some commands. It will contain frequency or mode information if such commands are issued. The FD Hex. at the end of the command string, informs the transceiver that the end of the command has been reached. After a transceiver receives a complete command string, it will process the command.

5.4 RESPONSE STRINGS - RADIO TO COMPUTER

After a transceiver has processed a command sent from a computer, it will send a response back to the computer that originated the command. This insures that the computer knows how the transceiver handled the command and also provides a method of pacing the commands because the computer knows not to send additional commands until it has received a response from the transceiver concerning the last command sent. If a computer sends a command to a transceiver that is not a status requesting command (a command that requests data to be sent back) the transceiver will respond either with a code indicating OK (FB Hex.) or NO GOOD (FA Hex.). The returned string will have the following format. The same general structure as described above is maintained but the transceiver is now the sender and the computer is now the receiver.

FEh FEh	RECEIVER ADDRESS	SENDER ADDRESS	FAh or FBh	FDh
---------	------------------	----------------	------------	-----

5.5 DATA FORMATS

When a computer sends frequency or mode setting commands to a transceiver, the command string will necessarily contain the requested frequency data or mode code. Frequency data must be encoded as a string of BCD digits in the order shown below. Each Hexadecimal number contains 2 BCD digits and must be properly encoded for the transceiver to process them. When frequency data is requested from a transceiver, it will also be in this format.

1st byte	2nd byte	3rd byte	4th byte
10Hz 1Hz	1Khz 100hz	100Khz 10Khz	10Mhz 1Mhz

FOR EXAMPLE: The frequency 14.03567 Mhz would be encoded as follows:

70 56 03 14

Since the TEN-TEC Model 563 has a tuning resolution of 10 Hz, and an upper frequency limit of 30 Mhz, the 1Hz digit is ignored and attempting to go beyond 30 Mhz will generate a 'NO GOOD' response from the transceiver.

When a mode selection command is sent, the mode must be encoded according to the following table:

LSB	00
USB	01
AM	02
CW	03
FM	05

When a transceiver returns its current operating mode to a computer, it will also be encoded in this format.

5.6 COMMANDS

Specific transceiver control commands can be found on the following pages. In use, each command must adhere to the structure discussed earlier. Included with the commands is a brief discussion of the possible transceiver response.

03h QUERY TRANSCEIVER FREQUENCY

This command sends the transceiver's current operating frequency to the requesting computer. The frequency data is returned as a string of BCD digits encoded as discussed previously.

COMMAND STRING SENT TO THE TRANSCEIVER:

FEh FEh RA SA 03h FDh
FEh FEh Command Prefix
RA Receiver Address (transceiver's address)
SA Sender Address (computer E0h)
03h Command code for frequency query
FDh Command String Terminator

RESPONSE STRING SENT TO THE COMPUTER:

The transceiver will respond by sending a return string that contains a data segment with the transceiver's frequency encoded in BCD format. The returned frequency represent the frequency of the currently active VFO.

FEh FEh RA SA DATA FDh
FEh FEh Command Prefix
RA Receiver Address (computer E0h)
SA Sender Address (Transceiver's address)
DATA Transceiver's frequency in BCD format
FDh Command string terminator

04h QUERY TRANSCEIVER MODE

This command sends the transceiver's current operating mode to the requesting computer.

COMMAND STRING SENT TO THE TRANSCEIVER:

FEh FEh RA SA 04h FDh
FEh FEh. Command Prefix
RA Receiver Address (transceiver's address)
SA Sender Address (computer E0h)
04h Command code for mode query
FDh Command String Terminator

RESPONSE STRING SENT TO THE COMPUTER:

The transceiver will respond by sending a return string that contains a data segment with the transceiver's mode encoded. The mode returned is from the displayed VFO.

FEh FEh RA SA DATA FDh
FEh FEh Command Prefix
RA Receiver Address (computer E0h)
SA Sender Address (Transceiver's address)
DATA Transceiver's mode encoded
FDh Command String Terminator

05h SET TRANSCEIVER FREQUENCY

This command updates the frequency of the currently selected VFO to data contained in the command string. Frequency data must be encoded.

COMMAND STRING SENT TO THE TRANSCEIVER:

FEh FEh RA SA 05h DATA FDh
FEh FEh Command Prefix

RA	Receiver Address (transceiver's address)
SA	Sender Address (computer E0h)
05h	Command code for mode query
DATA	BCD encoded frequency data
FDh	Command String Terminator

RESPONSE STRING SENT TO THE COMPUTER:

The transceiver will send a string that contains either the OK code (FBh) or a NO GOOD code if the operation failed. The operation will fail if the frequency data indicates a frequency that is beyond the capabilities of the transceiver.

FEh FEh RA SA FAh or FBh FDh	
FEh FEh	Command Prefix
RA	Receiver Address (computer E0h)
SA	Sender Address (Transceiver's address)
FAh or FBh	NO GOOD CODE or OK CODE
FDh	Command String Terminator

06h SET TRANSCEIVER MODE

This command changes the mode of the currently selected VFO to data contained in the command string. Mode data must be encoded.

COMMAND STRING SENT TO THE TRANSCEIVER:

FEh FEh RA SA 06h DATA FDh	
FEh FEh	Command Prefix
RA	Receiver Address (transceiver's address)
SA	Sender Address (computer E0h) 06h = Command code for mode query 06h
DATA	Desired mode encoded
FDh	Command String Terminator

RESPONSE STRING SENT TO THE COMPUTER:

The transceiver will respond by sending a string containing either the OK code (FBh) if the operation was performed, or a NO GOOD (FAh) code if the operation failed. The operation will fail if the requested mode is not available on the transceiver.

FEh FEh RA SA FAh or FBh FDh	
FEh FEh	Command Prefix
RA	Receiver Address (computer E0h)
SA	Sender Address (Transceiver's address)
FAh or FBh	NO GOOD CODE or OK CODE.
FDh	Command String Terminator

07h VFO SELECTION

This command provides for selection of a particular VFO. Besides the VFO selection code 07h, a sub command must be specified that indicates which VFO operation to perform.

COMMAND STRING SENT TO THE TRANSCEIVER:

FEh FEh RA SA 07h SC FDh	
FEh FEh	Command Prefix
RA	Receiver Address (transceiver's address)

SA	Sender Address (computer E0h)
07h	Command code for mode query
SC	Sub-Command:
00h	Select VFO A
01h	Select VFO B
A0h	Copies selected VFO to other VFO. ie VFO A = VFO B.
B0h	Swaps VFO contents. ie VFO A to VFO B and VFO B to VFO A.
FDh	Command String Terminator

RESPONSE STRING SENT TO THE COMPUTER:

The transceiver responds by sending a string containing either the OK code (FBh) if the operation was performed, or a NO GOOD code if the operation failed. The operation will fail if the requested mode is not available on the transceiver.

FEh FEh RA SA FAh or FBh FDh	
FEh FEh	Command Prefix
RA	Receiver Address (computer E0h)
SA	Sender Address (Transceiver's address)
FAh or FBh	NO GOOD CODE or OK CODE.
FDh	Command String Terminator

08h SELECT MEMORY CHANNEL

This command informs the transceiver which memory channel is to be used for subsequent memory operations. The memory channel number, in BCD format, must be within the memory channel limits of the transceiver or a NO GOOD will be returned.

COMMAND STRING SENT TO THE TRANSCEIVER:

FEh FEh RA SA 08h MC FDh	
FEh FEh	Command Prefix
RA	Receiver Address (transceiver's address)
SA	Sender Address (computer E0h)
08h	Command code for mode query
MC	Memory channel number in BCD format
FDh	Command String Terminator

RESPONSE STRING SENT TO THE COMPUTER:

The transceiver responds by sending a string containing either the OK code (FBh) if the operation was performed, or a NO GOOD code if the operation failed. The operation will fail if the memory channel is not available on the transceiver.

FEh FEh RA SA FAh or FBh FDh	
FEh FEh	Receiver Address (computer E0h)
SA	Sender Address (Transceiver's address)
FAh	NO GOOD CODE or OK CODE.
FDh	Command String Terminator

09h TRANSFER ACTIVE VFO TO MEMORY CHANNEL

This command transfers contents of the active VFO to the pre-specified memory channel. The memory channel should have been previously set using command 08h. If not, the last accessed

memory channel will be used for the operation.

COMMAND STRING SENT TO THE TRANSCEIVER:

FEh FEh RA SA 09h FDh
FEh FEh Command Prefix
RA Receiver Address (transceiver's address)
SA Sender Address (computer E0h)
09h Command code for mode query
FDh Command String Terminator

RESPONSE STRING SENT TO THE COMPUTER:

The transceiver responds by sending a string containing either the OK code (FBh) if the operation was performed, or a NO GOOD code if the operation failed.

FEh FEh RA SA FAh or FBh FDh
FEh FEh Command Prefix
RA Receiver Address (computer E0h)
SA Sender Address (Transceiver's address)
FAh NO GOOD CODE or OK CODE.
FDh Command String Terminator

0Ah COPY MEMORY CHANNEL TO ACTIVE VFO

Transceiver to copy data from the pre-specified memory channel into the currently active VFO. The memory channel should have been previously set using command 08h. If not, the last accessed memory channel will be used for the operation.

COMMAND STRING SENT TO THE TRANSCEIVER:

FEh FEh RA SA 0Ah FDh
FEh FEh Command Prefix
RA Receiver Address (transceiver's address)
SA Sender Address (computer E0h)
0Ah Command code for mode query
FDh Command String Terminator

RESPONSE STRING SENT TO THE COMPUTER:

Transceiver responds by sending a string containing either the OK code (FBh) if the operation was performed, or a NO GOOD code if the operation failed.

FEh FEh RA SA FAh or FBh FDh
FEh FEh Command Prefix
RA Receiver Address (computer E0h)
SA Sender Address (Transceiver's address)
FAh NO GOOD CODE or Ok CODE.
FDh Command String Terminator

0Fh SET/CANCEL SPLIT OPERATION

This command activates or cancels split operation of the transceiver. In addition to the SET/CLEAR SPLIT command code 0Fh, a sub command must be specified to indicate which operation to perform.

COMMAND STRING SENT TO THE TRANSCEIVER:

FEh FEh RA SA 0Fh SC FDh	
FEh FEh	Command Prefix
RA	Receiver Address (transceiver's address)
SA	Sender Address (computer E0h)
0Fh	Command code for mode query
SC	Sub-command: 00h = cancel split operation 01h = Set split operation
FDh	Command String Terminator

RESPONSE STRING SENT TO THE COMPUTER:

Transceiver responds by sending a string containing either the OK code (FBh) if the operation was performed, or a NO GOOD code if the operation failed.

FDh FDh RA SA FAh or FBh FDh	
FD FD	Command Prefix
RA	Receiver Address (computer E0h)
SA	Sender Address (Transceiver's address)
FAh	NO GOOD CODE or OK CODE.
FD	Command String Terminator

SPECIALIZED COMMAND MODES:

Some transceivers, such as TEN-TEC models 563, 535 and 536 provide an additional mode referred to as MATRIX MODE. MATRIX MODE allows a transceiver to operate as a controller for other transceivers connected to the serial interface. When the transceiver is placed in MATRIX MODE it will generate and accept MATRIX MODE COMMANDS. These commands are sent from any transceiver placed in MATRIX MODE and are in a format unique to MATRIX MODE. Other MATRIX MODE transceivers will accept the matrix mode commands but will not generate response. MATRIX MODE commands are generated from a MATRIX MODE transceiver when ever its operating status is changed (ie frequency or mode). By sending MATRIX MODE commands that contain this information, other MATRIX MODE transceivers will automatically track the transceiver that generated the commands. To activate MATRIX MODE on Models 535/536: press "SHIFT" and "SPLIT". "M.Lock" will appear in display. To activate MATRIX mode on Model 563: in USER'S MENU, turn CdE "ON".

**00h MATRIX MODE COMMAND
TRANSFER CURRENT OPERATING FREQUENCY TO ALL TRANSCEIVERS IN MATRIX
MODE**

This command, generated by a transceiver in MATRIX MODE, causes any other MATRIX MODE transceiver to mimic the operation of the transceiver that generated this command.

COMMAND STRING SENT TO THE TRANSCEIVER:

FEh FEh 00h SA 00h DATA FDh	
FEh FEh	Command Prefix
RA	00h Receiver Address that any MATRIX MODE transceiver will accept.
SA	Sender Address (transceiver address)
00h	Command code for mode query
DATA	Transceiver frequency, encoded in BCD format
FDh	Command String Terminator

RESPONSE STRING SENT TO THE COMPUTER: No transceiver responds to this transceiver generated command.

**01h MATRIX MODE COMMAND
TRANSFER CURRENT OPERATING MODE TO ALL TRANSCEIVERS IN MATRIX
MODE**

This command, generated by a transceiver in MATRIX MODE, causes any other MATRIX MODE transceiver to mimic the operation of the transceiver that generated this command.

COMMAND STRING SENT TO THE TRANSCEIVER:

FEh FEh 00h SA 00h DATA FDh

FEh FEh Command Prefix

RA 00h Receiver Address that any MATRIX MODE transceiver will accept.

SA Sender Address (transceiver address)

00h Command code for mode query 00h

DATA mode code, encoded in BCD.

FDh Command String Terminator

RESPONSE STRING SENT TO THE COMPUTER: No transceiver responds to this transceiver generated command.

5.7 EXPANDED COMMANDS FOR OMNI VI, MODEL 563 ONLY

0C HEX.: READ OFFSET FREQUENCY

This command queries the transceivers current offset frequency.

Transciever's response: The transceiver will respond by returning the current offset frequency in BCD format (2 bytes). Negative offset frequencies are returned in 9's compliment form.

Data: Transceiver's current offset frequency in BCD format.

0D HEX: WRITE OFFSET FREQUENCY

This command sets the transceivers current offset frequency.

Data: Offset frequency in BCD format. For negative values of offset, the format should be 9' compliment.

**13 HEX: ANNOUNCE FREQUENCY OF CURRENT VFO (OPTIONAL VOICE BOARD
REQUIRED)**

This command will activate the optional voice board and announce the frequency of the current VFO.

Transceiver's response: Returns NO GOOD if the voice board is not installed.

16 HEX: SET/CLEAR TRANSMIT MODE

This command and associated sub-commands control the transmitter.

These commands provide remote control of the transmit/receive functions but cannot override local control functions. Thus, if the PTT line is depressed, sending a RETURN TO RECEIVE command cannot override the PTT action.

SUB-COMMAND 01h	GO TO TRANSMIT
SUB-COMMAND 02h	RETURN TO RECEIVE

Transceiver's response: If the transceiver was able to perform the indicated operation, it will return the OK code.

COMMAND 17h: RETURN TRANSCEIVER STATUS

This command queries the transceiver's extended status information.

Transceiver's response: The transceiver will return the extended status information encoded in a 1 byte code encoded as listed below.

BIT POSITION		
0	SPLIT STATUS	(0=SPLIT OFF, 1=SPLIT ON)
1	VFO SELECTED	(0=VFO A, 1=VFO B)
2	TX STATUS	(0=RX, 1=TX)
3	RIT STATUS	(0=OFF, 1=ON)
4	XIT STATUS	(0=OFF, 1=ON)
5	VOX STATUS	(0=OFF, 1=ON)
6	LOCK STATUS	(0=OFF, 1=ON)
7	NOT USED	

18h RETURN TRANSMIT FREQUENCY

This command returns the true transmit frequency of the transceiver. Any transmit offset or split status will be included in the returned frequency.

COMMAND STRING SENT TO THE TRANSCEIVER:

FEh FEh RA SA 03h FDh
FEh FEh Command Prefix
RA Receiver Address (transceiver's address)
SA Sender Address (computer E0h)
03h Command code for frequency query
FDh Command String Terminator

RESPONSE STRING SENT TO THE COMPUTER:

The transceiver will respond by sending a return string that contains a data segment with the transceiver's frequency encoded in BCD format. The returned frequency represents the frequency of the currently active VFO.

FEh FEh RA SA DATA FDh
FEh FEh Command Prefix
RA Receiver Address (computer E0h)
SA Sender Address (Transceiver's address)
DATA Transceiver's frequency in BCD format
FDh Command string terminator

19h RETURN RECEIVE FREQUENCY

This command returns the true receive frequency of the transceiver. Receive offset and split operation are included in the returned frequency.

COMMAND STRING SENT TO THE TRANSCEIVER:

FEh FEh RA SA 03h FDh
FEh FEh Command Prefix
RA Receiver Address (transceiver's address)
8A Sender Address (computer E0h)
03h Command code for frequency query
FDh Command String Terminator

RESPONSE STRING SENT TO THE COMPUTER:

The transceiver will respond by sending a return string that contains a data segment with the transceiver's frequency encoded in BCD format. The returned frequency represent the frequency of the currently active VFO.

FEh FEh RA SA DATA FDh
FEh FEh Command Prefix
RA Receiver Address
SA Sender Address (Transceiver's address)
DATA Transceiver's frequency in BCD format
FDh Command string terminator

CHAPTER 6

TROUBLE SHOOTING PROCEDURES

If the transceiver should fail to operate normally, use the following chart as an aid in determining the problem. Often the cause of the problem is an overlooked switch / control or a mistake in entering information into the keypad. Of course, you may call the Service Department (1-615-428-0364) and ask for assistance should you need it.

<u>SYMPTOM</u>	<u>POSSIBLE CAUSE</u>
Transceiver dead, no meter lamp, no display	<ul style="list-style-type: none">- Quickly Reset microprocessor with Master Reset (2-4.3)- Check power switches on radio and power supply- Check power cable to radio- Check fuses on radio and power supply- Check polarity and correct voltage of power supply- Check wall outlet for power supply- Be sure Ten-Tec power supply is not tripping off due to high SWR (1-2)
Transceiver OK, no meter lamp or display (or very low)	<ul style="list-style-type: none">- DIM function (on keypad) set to minimum (3-1.16)
Receiver dead, meter lamp and display on	<ul style="list-style-type: none">- Check AF and RF GAIN controls (2-2)- Check headphone and EXTERNAL SPKR jacks. (3-6.01)- Check to be sure radio is not in TRANSMIT (3-1.03)- Check CRYSTAL FILTER SELECTION. Be sure filter is installed. (3-1.10)- Check MAIN / AUX Antenna switch for proper antenna selection (3-5.15)- Check Antenna coax and associated items.- Check PBT control (should be centered) (3-5.12)- If in FM, check SQUELCH (3-5.11)- Check MUTE jack, if used (3-6.10)

TROUBLE SHOOTING PROCEDURES (Cont.)

<u>SYMPTOM</u>	<u>POSSIBLE CAUSE</u>
Weak Receive	<ul style="list-style-type: none"> - Check MAIN / AUX Antenna switch for proper antenna selection (3-5.15) - Check RF GAIN control (3-5.09) - Check ATTN switch (3-5.05) - Check for proper CRYSTAL FILTER selection (3-1.10) - Check PBT control (should be centered) (3-5.12) - Check Antenna coax and associated items
Distorted Received CW / AMTOR / PACKET / RTTY signals	<ul style="list-style-type: none"> - Check AUTO NOTCH switch (should be off) (3-5.13) - Check AGC ON / OFF switch (should be on) (3-5.07)
Distorted Received SSB Signals	<ul style="list-style-type: none"> - Check AGC ON / OFF switch (should be on) (3-5.07) - May need to activate -20 dB ATTENUATOR (3-5.05) - Check for proper mode selection (3-1.02)
Transmit frequency different from Receive frequency	<ul style="list-style-type: none"> - Check SPLIT function (3-2.2) (normally OFF) - Check RIT / XIT (3-2.3, 3-2.4)
Distorted Transmit signals	<ul style="list-style-type: none"> - Check ground system - Check antenna system SWR - Check for strong RF field in shack - Reset microprocessor - PROCESSOR level turned up too high (3-5.04)
Frequencies will not store in memories	<ul style="list-style-type: none"> - Be sure to press M>VFO key quickly. If button held too long, frequency will go to SCRATCH PAD MEMORY (3-3.3)
Main or remote tuning knob will not change frequency	<ul style="list-style-type: none"> - Check LOCK (normally OFF) - Be sure you are not in VOX SETUP routine (3-1.11) - Be sure you are not in SIDETONE SETUP routine (3-1.13)

TROUBLE SHOOTING PROCEDURES (Cont.)

<u>SYMPTOM</u>	<u>POSSIBLE CAUSE</u>
Keypad will not respond to input, main tuning knob will not change frequency	- Reset microprocessor with PARTIAL RESET. If radio still does not respond, use a MASTER RESET. (2-4.3)
No readout, audio present	- USER OPTIONS MENU activated (3-4)
Readout present, can not enter commands	
Clock resets to 12:00 when radio turned off	- Replace 3 volt Lithium battery (CR-2032;DL-2032) on Logic Board (81606). See pg 4-27 & 4-28.
Memories and USER Options clear out when radio turned off	
Beep heard every 10 - minutes	- ID timer turned on in USER OPTIONS MENU (3-4)
Linear amplifier will not key using RELAY N. O. jack on rear panel	- LOC option in USER OPTIONS MENU not turned ON (3-4)
Linear amplifier will not key using TX OUT / TX EN jacks (TEN-TEC LINEARS)	- Be sure TX OUT / TX EN cables are not swapped. (3-6.09) - Check TX OUT / TX EN cable continuity
Radio stays in Transmit when turned on	- Check CW KEY / KEYSER PADDLE cable for short - Check PTT line (cable) for short - Check mic cable for short on PTT wire (pin 3) - Check computer terminal unit for short on PTT line. - Check VOX GAIN, if used (3-1.11)