

YAESU

# GS-23 & GS-232

*Computer Control Interfaces  
for Antenna Rotators*



Downloaded by  
RadioManual.EU

# GS-23 & GS-232 Computer Control Interfaces

## for Yaesu Antenna Rotators

The GS-23 and GS-232 provide digital control of most models of Yaesu antenna rotators from the serial port of an external personal computer. The GS-23 is an optional expansion board that can be installed in the Controller Unit of Yaesu Model G-800SDX, G-1000SDX and G-2700SDX Antenna Rotators for azimuth control, and can also be used with the G-500A Elevation Rotator when coupled through the optional GX-500 Automatic Control Adapter.

The GS-232 is the same board in an external box for use with the G-5400B/-5600B Az-El Rotator, or the G-400/G-500A az/el rotator combination (the G-400/G-500A combination requires two GX-500 Automatic Control Adapters).

The GS-23/-232 contains its own microprocessor with ROM and RAM (memory), and a 10-bit analog-to-digital (A-D) converter. The 3-wire async serial line can be configured for serial data rates from 150 to 9600 baud. The GS-23 includes a 1-meter serial cable with a DB-25P male plug for connection to the

computer (a gender changer may be required). The GS-232 has a DB-25S female connector for a user-supplied serial cable.

Firmware on the GS-23/-232 supports either direct keyboard control, or commands from programs written specifically to support it (software is not supplied by Yaesu). In addition to reading and setting antenna angle and rotation speed, the firmware includes clocked positioning routines to automatically step the antenna through up to 3800 angles at programmable intervals, such as for tracking band openings or satellites (with an elevation rotator). The GS-232 includes a set of LED indicators to indicate the status of the control signals.

Please read this manual carefully to install the GS-23 and GS-232. If also installing a G-400 or G-500A with the GX-500 Automatic Control Adapter, follow the procedures in the GX-500 manual before installing the GS-23/-232.

## *Specifications*

Microprocessor: HD6303P  
ROM: 27C64  
RAM: 6264  
A/D Converter: HD46508P (10 bits)  
Serial Comms:  
    3-wire Async. DCE  
    RS-232C voltage levels  
    150 to 9600 baud, 8 data bits,  
    1 stop bit, no parity, no handshake

## *Supplied Items*

### *GS-23:*

Circuit Board  
RS-232C Connection Cable  
8-wire Cable (for internal connection)  
M-3x6 Mounting Screws (4 pcs)

### *GS-232:*

Circuit Board and Housing  
Dual 5-pin-to-DIN cable for G-5400B Rotator  
2 5-pin-to-5-pin cables for G-400 & G-500A  
Fused (1-A) DC cable w/coaxial plug & fuse  
2 hook & loop fasteners (for mounting)

## *Connector Pinouts*

Serial I/O (3-pin connector CN-1 on GS-23, 25-pin DB-25S connector on GS-232):

CN-1 pin 1 or DB-25S pin 2 – Rx Data  
CN-1 pin 2 or DB-25S pin 3 – Tx Data  
CN-1 pin 3 or DB-25S pin 7 – Sig. Ground

Rotator Control (5-pin. CN-2 on GS-23, and CN-1 and CN-2 on GS-232) :

- (1) UP/RIGHT switch (open collector)
- (2) DOWN/LEFT switch (open collector)
- (3) no connection
- (4) analog input (0-5V elevation)
- (5) analog ground

GS-23 Power & Azimuth Control (CN-3):

- (1) CW switch (open collector)
- (2) CCW sw. (open collector)
- (3) analog output (0-5V, rotation speed, in 4 steps)
- (4) analog input (0-5V azimuth)
- (5) analog ground
- (6) -12V in (approx 7mA)
- (7) +12V in (approx 16mA)
- (8) +12V in (approx 65mA)

# Installation

During installation, a personal computer with a serial port and terminal software is required to calibrate trimmers on the Controller and on the Control Interface. Any simple interactive terminal program can be used - it only has to transmit keystrokes as typed, and display characters received from the GS-23/-232.

## *Mounting the Board (GS-23 only)*

- Remove the four screws in the feet, and the two on the sides of the Controller near the upper rear corners (see diagram on next page). Remove the cover.
- Remove the two screws affixing the cable subpanel from the top edge of the rear panel of the Controller.
- Position the GS-23 Circuit Board on top of the Controller chassis so that the **RESET** switch is at the rear right corner, and affix the Board with the four supplied screws.
- Connect the Controller to the Board using the supplied 8-wire cable, from the exposed 8-pin connector at the left of the Board to connector CN-3 on the Board. The connectors are polarized.
- If your installation includes an elevation rotator, you should have the GX-500 already installed on your rotator. The 5-wire cable supplied with the GX-500 is used to connect the GS-23 with the GX-500. Route the end of this cable that has the longest exposed wires through the rubber grommet in the cable subpanel removed above, and connect it to connector CN-2 on the Board. The other end goes to the 5-pin connector on the GX-500.
- Referring to the diagram on the page after next, route the end of the RS-232C cable with the small connector through the rubber grommet in the cable subpanel removed above, and connect it to connector CN-1 on the Board.
- Replace the two screws removed from the cable subpanel, including the ground lug on the RS-232C cable under the screw nearest the center of the Controller.
- Remove the plastic cable clamp on the back of the Controller, near the bottom. Route the RS-232C cable through this clamp, and replace it.

Before replacing the top cover, screws and feet, connect your computer and perform the calibration procedures in the following sections.

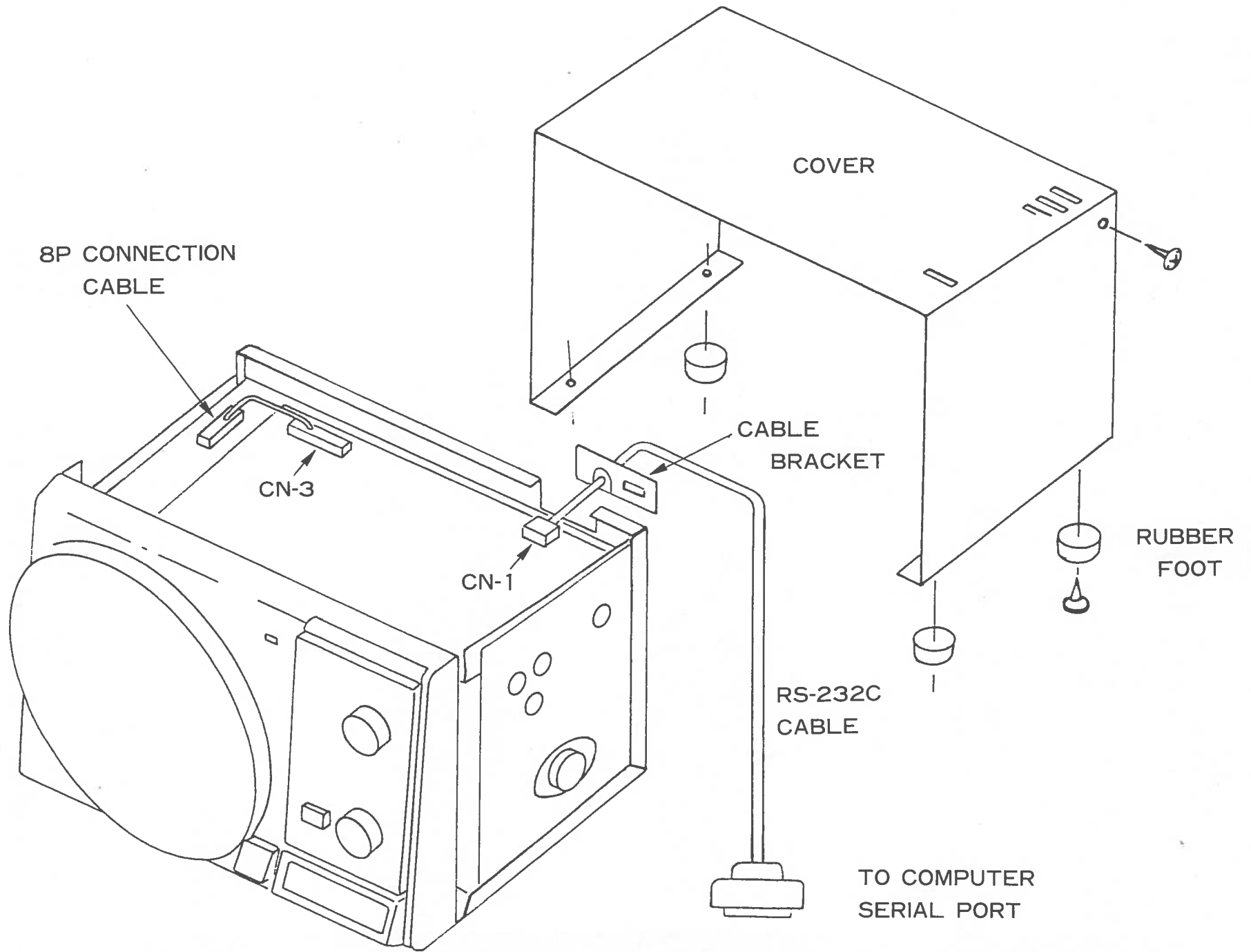

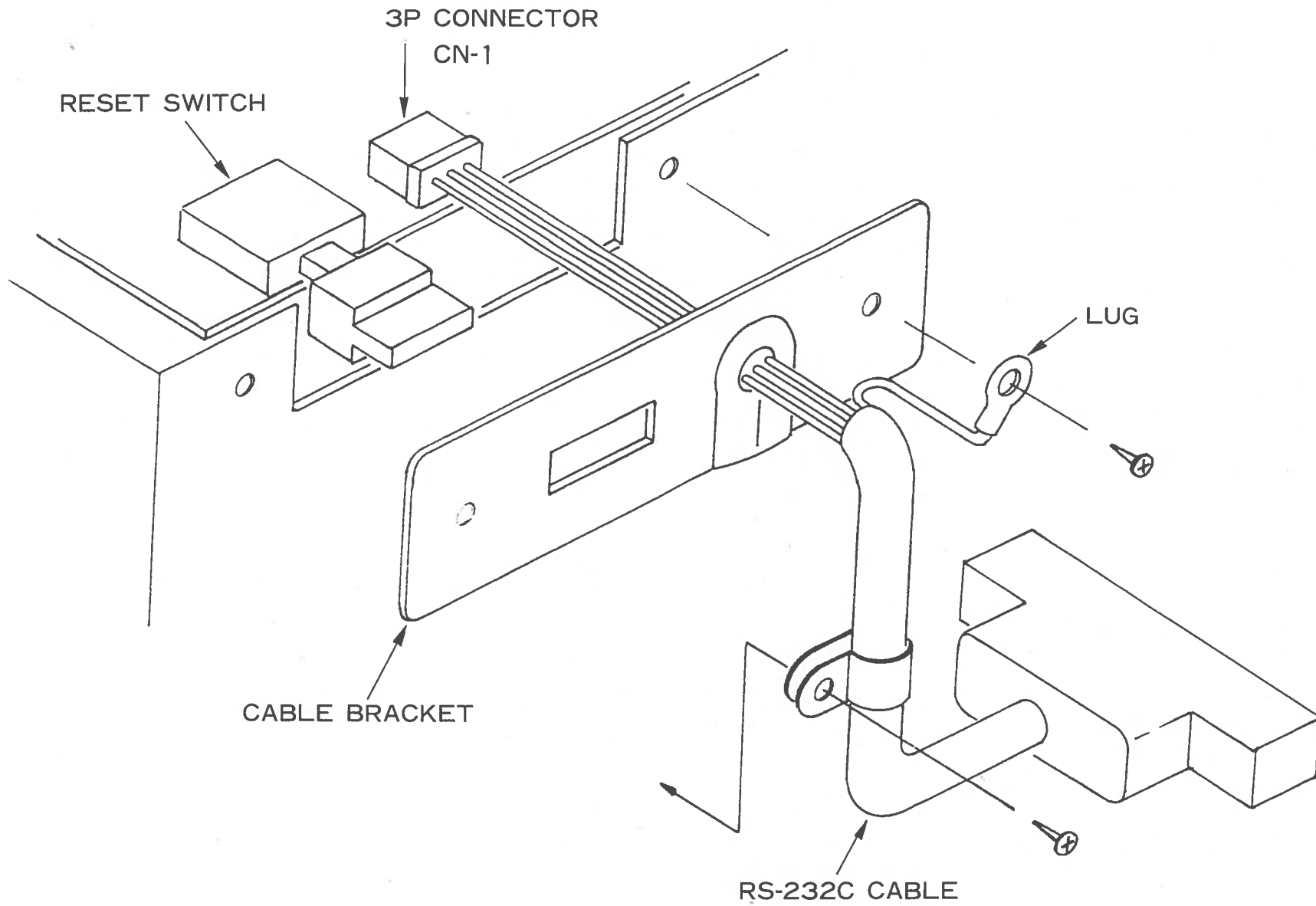

## *GS-232 Power & Control Connections*

The supplied cable has a 500-mA fast-blow fuse. Use only the same type fuse for replacement.

- Connect the supplied red and black cable to a source of 13.8 VDC. The GS-232 requires 100mA.
- Plug the coaxial power connector into the jack on the GS-232.
- If you are using a G-5400B or G-5600B Az-El rotator, connect it to the GS-232 using the dual 5-pin-to-DIN cable supplied with the GS-232. Be careful to match the AZ and EL labels on the cable with the same labels on the rear of the GS-232.
- If you are using the G-400 and a GX-500, or G-400/G-500A and a pair of GX-500's with the GS-232, use the 5-wire cables supplied with the GS-232 to connect to the GX-500(s). The 5-wire cable supplied with the GX-500 is not used in installations with the GS-232.
- Remove the four screws affixing the top cover of the GS-232 (to access the board during alignment).

### *Computer Connection*

- With the computer switched off, connect the RS-232C cable to the serial port of the computer. If the GS-23 connector does not match, use an uncrossed

female-to-female gender changer (the GS-23 is a DCE device). For the GS-232, connect the other end of your serial cable to the back of the GS-232. Only three wires are used for serial control, so there is no hardware handshaking (no RTS/CTS or DTR/DSR connections).

- Select the desired data rate with the DIP switch bank on the Control Interface board, as follows:

#### *Baud Setting DIP Switches*

Baud	DIP Switch			
	1	2	3	4
150	ON	ON	ON	ON
300	OFF	ON	ON	ON
600	ON	OFF	ON	ON
1200	ON	ON	OFF	ON
2400	ON	ON	ON	OFF
4800	OFF	OFF	ON	ON
9600	ON	ON	OFF	OFF

- The Control Interface serial data format uses 8 data bits, no parity and 1 stop bit, with no handshaking. Turn on the computer and Controller (and GS-232, if it is being installed) and set up your terminal program for this format and your selected data rate on the serial port to be used for rotator control.

## Calibration

### Azimuth Offset Null

- From the Controller panel, set the rotator fully counterclockwise.
- Press 0↵ (the letter “oh”, and Enter) on the computer keyboard to activate the azimuth calibration routine. The computer display should show **AZaaaa=bbbb** returned from the Interface Board, where *aaaa* and *bbbb* are 4-digit numbers padded at the left with zeros.
- Adjust the **AZ** trimmer (near the front left corner of the GS-23 Board, or rear right corner of the GS-232 Board) while watching the computer display, until 4-digit numbers *aaaa* and *bbbb* on either side of the equals sign are the same (they will change during the adjustment).
- Press the **RESET** button on the rear edge of the GS-23 (or toggle the GS-232 **POWER** switch) to exit azimuth calibration.

If you are not installing an elevation rotator go on to *Azimuth A-D Calibration*.

### Elevation Offset Null

- From the Elevation Controller panel, set the rotator to the horizon (down, 0°).

- Press 02↵ (the letter “oh”, 2, and Enter) on the keyboard to activate the elevation calibration routine. The computer should show **AZaaaa=bbbb**, as in the previous procedure, and also **ELccc=dddd** to the right, where *ccc* and *ddd* are 4-digit numbers padded at the left with zeros.
- Adjust the **EL** trimmer (near the front left corner of the GS-23, or the rear left corner of the GS-232) while watching the computer display, until 4-digit numbers *ccc* and *ddd* on either side of the equals sign are the same.
- Press the **RESET** button on the rear edge of the GS-23 (or toggle the GS-232 **POWER** switch) to exit the elevation calibration routine.

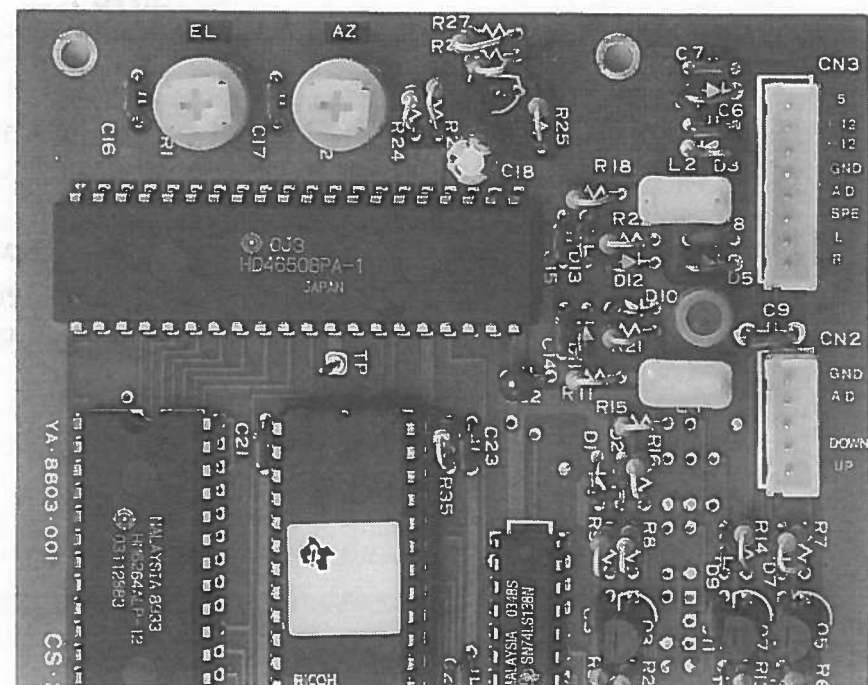



### *Azimuth A-D Calibration*

- From the Controller panel, set the rotator fully clockwise (450°).
- Press F.↓ to activate the Control Interface's A-D converter calibration routine. The computer should display +aaaa, where aaaa is a 4-digit number indicating azimuth, in degrees.
- Adjust the position indicating voltage offset of the azimuth rotator while watching the computer display, until the 3-digit number is 0450. This adjustment is labeled **OUT VOL ADJ** nearest the bottom of the rear of Controllers used with the GS-23, or **FULL SCALE ADJ** on the GX-500 (only when used with the G-400 for azimuth control!), or the innermost of the two controls above the **AZIMUTH** terminal block on the G-5400B/-5600B.
- Press the **RESET** button on the GS-23 (or toggle the GS-232 **POWER** switch) again.

If not installing an elevation rotator, skip the next procedure and replace the top cover of the Controller, and the feet and six screws (or the cover of the GS-232 and its four screws).

### *Elevation A-D Calibration*

- From the Elevation Controller panel, set the rotator straight up (180°).
- Press F2.↓ to activate the Control Interface's A-D converter calibration routine. The computer should display +aaaa+eeee, where eeee is a 4-digit number indicating elevation, in degrees (aaaa is azimuth, which can be ignored in this procedure).
- Adjust the **FULL SCALE ADJ** potentiometer on the GX-500 adapter (or the innermost of the two controls above the **ELEVATION** terminal block on the G-5400B/-5600B) while watching the computer display, until the 4-digit number is 0180.
- Press the **RESET** button on the GS-23 (or toggle the GS-232 **POWER** switch) again.
- Replace the top cover of the Controller, and the feet and six screws (or the cover of the GS-232 and its four screws).

If you wish, you can mount the GS-232 on top of your Rotator Controller using the two supplied hook-and-loop fastener strips. Just remove the backing from one side of each strip, and press into place on the bottom of the GS-232. Then remove the backing from the other side, and press the GS-232 into place on the Controller.

# Operation

After installation and calibration, the Control Interface can accept commands entered directly from the keyboard, or from a program written specifically to support it (not supplied by Yaesu). For brief summaries of the commands recognized by the Control Interface, press H↵ for a list of azimuth commands, or H2↵ for elevations commands. Keep in mind that all commands require that the **Enter** key be pressed after the command letter (or 0Dh be sent by a control program), although we will not repeat this when discussing the commands. Also note that any command letter may be sent in either upper or lower case. The info screens shown on the next page will be returned by the Control Interface.

Most commands have two versions: one for azimuth, and one for elevation. Commands are not echoed by the Control Interface, but a carriage return character (0Dh) is returned after every command, and also a line feed character (0Ah) if the command invoked returned data. Invalid commands cause “?>” to be returned and the input buffer cleared. Note that all angles are in degrees, beginning with zero at the most counterclockwise azimuth (or horizontal elevation). Angles sent to the Control Interface must be 3 digits

long (left-zero-padded), and angles returned will, in some cases, be 4 digits long with a leading “+0”.

In the following command descriptions, the elevation version of each command, where there is one, is shown in parentheses (but don't type the parentheses). Remember that elevation commands require the G-5400B or G-5600B AzEl rotators, or the GX-500 adapter and the G-500 elevation rotator.

0 (02)

Offset calibration for internal **AZ (EL)** trimmer potentiometer: preset rotator manually fully counterclockwise, send command, and adjust trimmer on Control Interface until returned values are equal. Press **RESET** (or toggle **POWER**) to store settings.

H (H2)

Returns list of commands (see next page).

F (F2)

Full Scale Calibration: preset rotator manually to full scale, send command, adjust **OUT VOL ADJ** trimmer on rear of controller (or CX-500 elevation adapter) until the returned data is “+0450” (“+0nnn+0180” for elevation). Press **RESET** (or toggle **POWER**) when done to save new settings.

Returned by H Command:

-----COMMAND LIST 1-----  
R Clockwise Rotation  
L Counter Clockwise Rotation  
A CW/CCW Rotation Stop  
C Antenna Direction Value  
M Antenna Direction Setting. MXXX  
M Time interval Direction  
Setting. MTTT XXX XXX XXX ---  
(TTT=Step value)  
(XXX=Horizontal Angle)  
T Start Comand in the time interval  
Ddirection setting mode.  
N Total number of setting angle in  
'M' mode and traced number of all  
datas(setting angles)  
X1 Rotation Speed 1(Horizontal)Low  
X2 Rotation Speed 2(Horizontal)Middle 1  
X3 Rotation Speed 3(Horizontal)Middle 2  
X4 Rotation Speed 4(Horizontal)High  
S All Stop  
O Offset Calibration  
F Full Scale Calibration  
(after calibration push reset switch)  
(V1.2) Copyright 1988.6 by KENPRO

Returned by H2 Command:

-----HELP COMMAND 2-----  
U UP Direction Rotation  
D DOUN Direction Rotation  
E UP/DOWN Direction Rotation Stop  
C2 Antenna Direction Value  
W Antenna Direction Setting.  
WXXX YYY  
W Time Interval Direction  
Seting. WTTT XXX YYY XXX YYY ---  
(TTT=Step value)  
(XXX=Horizontal Angle)  
(YYY=Elevation Angle)  
T Start Command in the time interval  
direction setting mode.  
N Total number of setting angle in  
'W' mode and traced number of all  
datas(setting angles)  
S All Stop  
O2 Offset Calibration  
F2 Full Scale Calibration  
B Elevation Antenna Direction Value  
(V1.2) Copyright 1988.6 by KENPRO

R (U)

Start turning the rotator to the right (up).

L (D)

Start turning the rotator to the left (down).

A (E)

Stop azimuth (elevation) rotation.

S

Stop: cancel current command before completion.

C (B)

Return current azimuth (elevation) angle in the form "+0*nmn*" degrees.

C2

Return azimuth and elevation ("+0*aaa*+0*eee*", where *eee* = elevation, *aaa* = azimuth).

X*n*

Select azimuth rotator turning speed, where *n*=1 (slowest) to 4 (fastest). This command can be issued during rotation, and takes effect immediately. There is no equivalent for elevation.

M*aaa*

Turn to *aaa* degrees azimuth, where *aaa* is three digits between 000 and 450. Rotation starts.

M*sss aaa bbb ccc ...*

This command, together with the T command, provides automatic, timed tracking of moving objects or propagation by the Control Interface itself. This command stores the time value *sss* seconds to wait between stepping from azimuth *aaa* to *bbb*, and then to *ccc*, etc. (from 2 to as many as 3800 angles may be stored with one command).

Note that this command is completely different than the F105MM command with only one parameter: when multiple parameters are present, the first one is interpreted by the Control Interface as the rotation interval *sss*, not an angle. Valid ranges are 001 to 999 for *sss*, and 000 to 450 for the angles.

When this command is sent, the parameters are stored in the Control Interface's RAM, and the rotator turns to angle *aaa* and waits for a subsequent T command to begin the actual stepping. All numbers must be 3 digits, space-separated. Stored values remain in effect until another M command is issued (this may have no parameters, in which case the "?>" error prompt is returned, but memories are still cleared), or until the controller is turned off or manually reset by the rear panel button (or by toggling the GS-232 off and on).

T

See the M above and the W command below. Start automatic stepping routine (both azimuth and elevation): turn rotator to next sequentially memorized azimuth (or az-el pair, for the W command), wait *sss* seconds, and turn to next angle (or pair), etc. This command works only if a long-form M or W has been issued since power-up or the last reset.

N

Return serial number of currently selected memorized point [*nnnn*], and total number of memorized points [*mmmm*], in the form *+nnnn+mmmm*. Must be preceded by either a long-form M or W, and a T command. Used only during stepping (see T).

The meaning of a “point” in this command following an M command is only an azimuth angle, so in this case *nnnn* and *mmmm* can range up to 3800 (the limit of available RAM in the Control Interface). However, when elevation is involved, a “point” following a W command is represented by both an azimuth and an elevation angle, in which case *nnnn* and *mmmm* can range up to only 1900, since each “point” is a pair of angles.

### *Elevation Control Commands*

These commands are only for az-el operation. Note that an azimuth angle must always be supplied when

changing elevation, and that a setting point consists of a pair of angles, as described for the N command.

*WIaaa eee*

Turn to *aaa* degrees azimuth and *eee* degrees elevation, where *aaa* is three digits between 000 and 450, and *eee* is three digits between 000 and 180. Rotators respond immediately.

*Wsss aaa eee aaa eee ...)*

This command is similar to the M command: the first parameter is a time interval, and succeeding parameters are angles. With this command, however, angles are in azimuth-elevation *pairs*, each pair representing one antenna location. At most 1900 pairs can be sent and stored in the Control Interface. As with the other commands, the time interval range is limited to 001 to 999 (seconds), azimuth to 000 to 450, and elevation to 000 to 180.

When this command is sent, the rotators turn to the first *aaa* azimuth parameter and the first *eee* elevation parameter, and wait for a subsequent T command to begin the actual stepping (to the next azimuth-elevation pair). Stored values remain in effect until another W command is issued (this may have no parameters, in which case the “?>” error prompt is returned, but memories are still cleared), or until the controller is turned off or manually reset by the rear panel button.

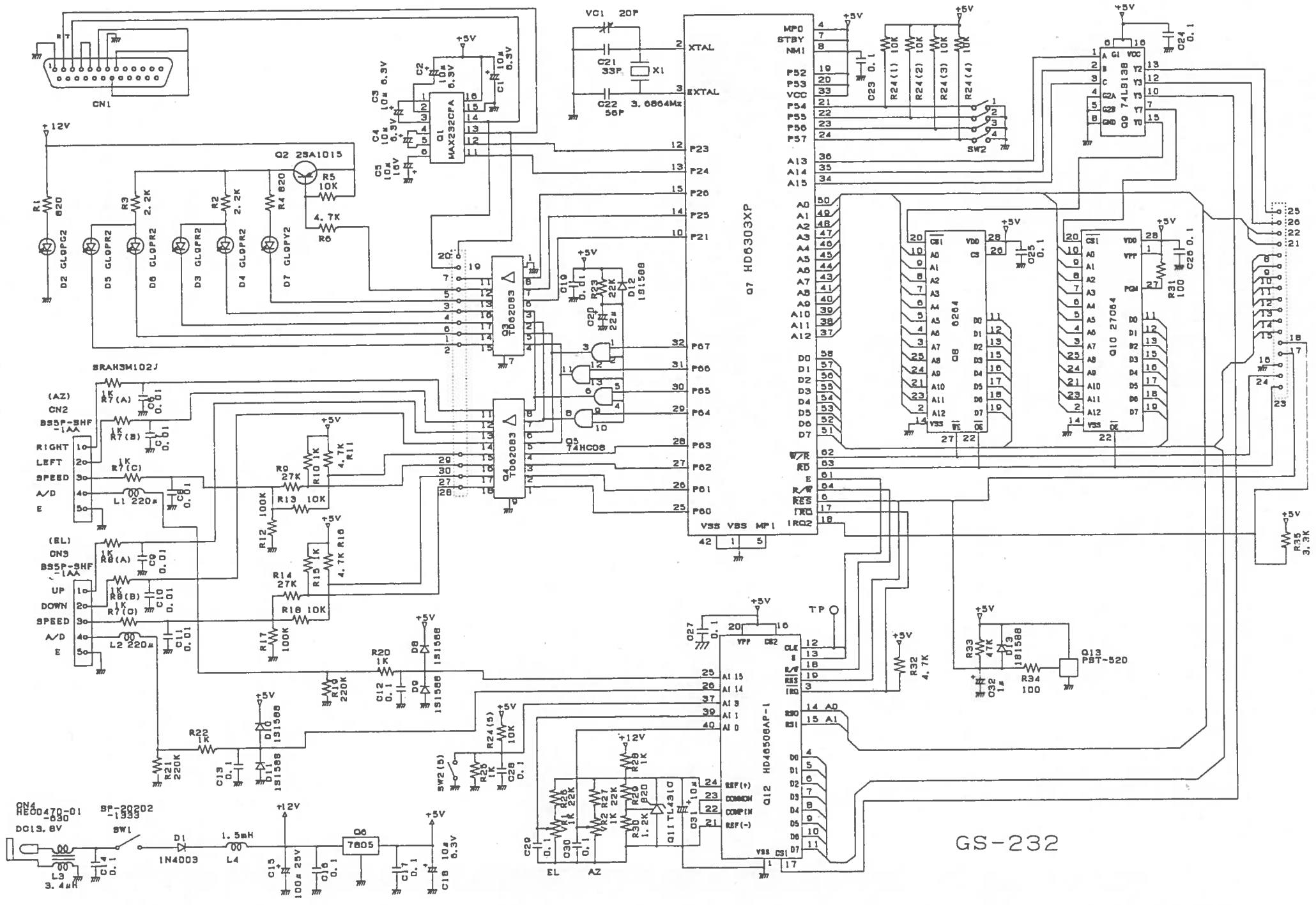

GS-232



**YAESU MUSEN CO., LTD.**

C.P.O. BOX 1500, TOKYO, JAPAN

**YAESU U.S.A.**

17210 Edwards Rd., Cerritos, California 90701, U.S.A.

**YAESU EUROPE B.V.**

Snipweg 3. 1118AA Schiphol, The Netherlands

**Downloaded by  
RadioManual.EU**