



VHF/UHF

**ULTRA-COMPACT DUAL-BAND TRANSCEIVER
WITH WIDE BAND COVERAGE**

VX-2R

OPERATING MANUAL

VERTEX STANDARD CO., LTD.

4-8-8 Nakameguro, Meguro-Ku, Tokyo 153-8644, Japan

VERTEX STANDARD

US Headquarters

10900 Walker Street, Cypress, CA 90630, U.S.A.

International Division

8350 N.W. 52nd Terrace, Suite 201, Miami, FL 33166, U.S.A.

YAESU EUROPE B.V.

P.O. Box 75525, 1118 ZN Schiphol, The Netherlands

YAESU UK LTD.

Unit 12, Sun Valley Business Park, Winnall Close
Winchester, Hampshire, SO23 0LB, U.K.

VERTEX STANDARD HK LTD.

Unit 5, 20/F., Seaview Centre, 139-141 Hoi Bun Road,
Kwun Tong, Kowloon, Hong Kong

Contents

General Description	1	Memory Mode	36
Controls & Connections	2	Regular Memory Operation	37
Keypad Functions	3	Memory Storage	37
Display Icons & Indicators	3	Storing Independent	
Accessories & Options	4	Transmit Frequencies (“Odd Split”)	37
Installation of Accessories	5	Memory Recall	38
Antenna Installation	5	HOME Channel Memory	38
Installation of the Supplied Belt Clip	5	Labeling Memories	39
Installation of FNB-82LI Battery Pack	6	Memory Offset Tuning	40
Interface of Packet TNCs	7	Masking Memories	41
Operation	8	Moving Memory Data to the VFO	41
Switching Power On and Off	8	Memory Bank Operation	42
Adjusting the Volume Level	8	Memory Only Mode	43
Squelch Adjustment	9	Special Memory Channel Operation	44
Selecting the Operating Band	10	Weather Broadcast Channels	44
Frequency Navigation	11	VHF Marine Channels	45
Transmission	12	Sort-wave Broadcast Station	
Keyboard Locking	13	Memory Channels	46
Keypad/LCD Illumination	14	Scanning	47
Disabling the Keypad Beeper	14	VFO Scanning	48
Advanced Operation	15	How to skip (Omit) a Frequency	
Checking the Battery Voltage	15	during VFO Scan	49
Changing the Channel Steps	15	Memory Scanning	50
Changing the Receiving Mode	16	Temporary Memory Skip	50
Display Dimmer	16	How to Skip (Omit) a Channel	
RF Squelch	17	during Memory Scan Operation	50
Repeater Operation	18	Preferential Memory Scan	51
CTCSS Operation	21	Programmable (Band Limit) Memory Scan	
DCS Operation	22	(PMS)	52
Tone Search Scanning	23	“Priority Channel” Scanning	
CTCSS/DCS Bell Operation	24	(Dual Watch)	52
Split Tone Operation	24	Automatic Lamp Illumination	
Tone Calling (1750 Hz)	25	on Scan Stop	53
ARTS (Automatic Range Transponder System)	26	Band Edge Beeper	53
DTMF Operation	29	Smart Search Operation	54
Emergency Channel Operation	31	Channel Counter Operation	56
ATT (Front End Attenuator)	31	Internet Connection Feature	58
Receive Battery Saver Setup	32	Sensor Mode	68
TX Battery Saver	32	Reset Procedures	60
Automatic Power-Off (APO) Feature	33	Cloning	61
Transmitter Time-Out Timer (TOT)	34	Set Mode	62
Busy Channel Lock-Out (BCLO)	34	Specifications	74
Changing the TX Deviation Level	35	“AUTO” Mode Preset Operating Parameters	75

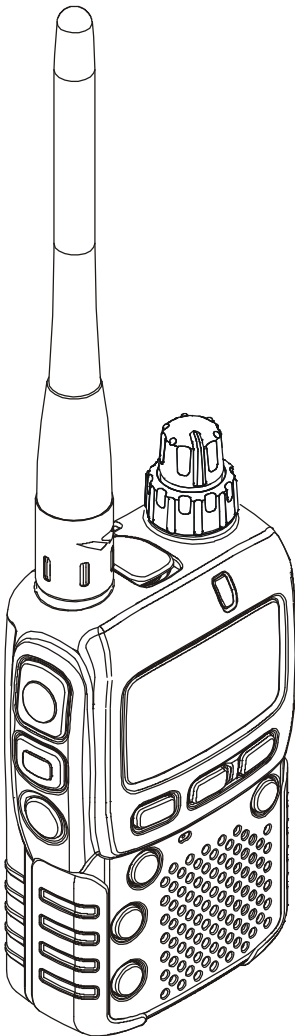

The **VX-2R** is a micro-miniature multiband FM transceiver with extensive receive frequency coverage, providing local-area two-way amateur communications along with unmatched monitoring capability.

The **VX-2R**'s incredibly small size allows you to take it anywhere - hiking, skiing, or while walking around town - and its operating flexibility brings the user many avenues of operating enjoyment. Its incredibly tiny **FNB-82LI** Lithium-Ion Battery Pack provides up to 1½ Watts of transmit power on VHF, and 1 Watt on UHF. Besides 144- and 430-MHz transceive operation, the **VX-2R** provides receive coverage of the AM (MF) and FM broadcast bands, HF Shortwave Bands, VHF and UHF TV bands, the VHF AM aircraft band, and a wide range of commercial and public safety frequencies!

Additional features include a convenient access key for Vertex Standard's **WIRES™** (Wide-Coverage Internet Repeater Enhancement System), a transmit Time-Out Timer (TOT), Automatic Power-Off (APO), Automatic Repeater Shift (ARS), Yaesu's exclusive **ARTS™** (Auto-Range Transponder System) which "beeps" the user when you move out of communications range with another **ARTS™** equipped station, plus provision for reduction of the TX deviation in areas of high channel congestion. And an RF squelch circuit allows the owner to set the squelch to open at a programmable setting of the S-Meter, thus reducing guesswork in setting the squelch threshold.

We appreciate your purchase of the **VX-2R**, and encourage you to read this manual thoroughly, so as to learn about the many exciting features of your exciting new Yaesu hand-held transceiver!

CONTROL & CONNECTIONS

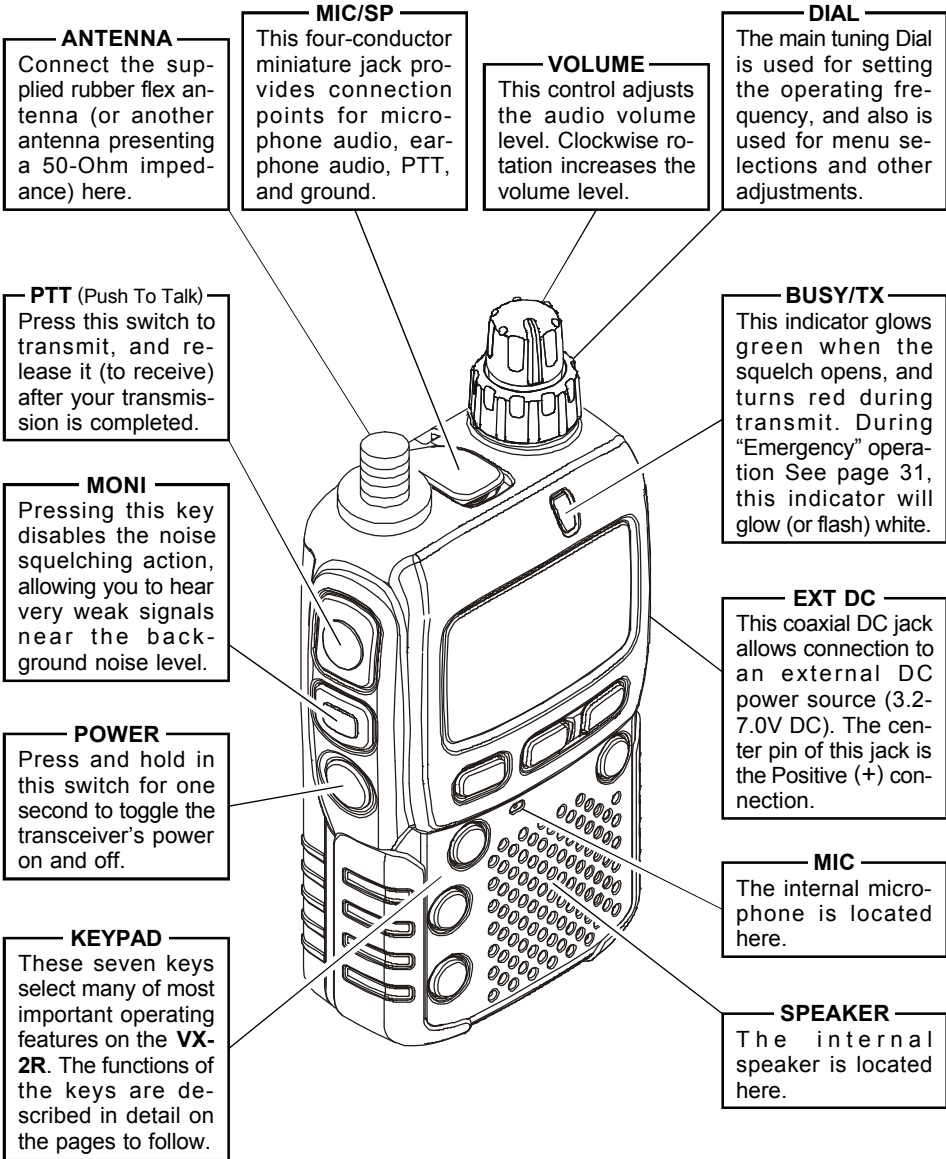

CONTROL & CONNECTIONS

KEYPAD FUNCTIONS

Key	Press Key	Press + [F/W] Key	Press and Hold Key
[BAND] Key	Moves operation to the next-highest frequency band. Activates the "Memory Bank" feature while in the Memory Recall mode.	Moves operation to the next-lowest frequency band.	Activates the Scanner.
[H/L] Key	Switches the transmit power output between "HI" and "LOW."	Selects the synthesizer steps to be used during VFO operation.	Enters the Set (Menu) Mode.
[V/M] Key	Switches frequency control between the VFO and Memory Systems.	Activates the "Memory Tune" function while in the Memory Recall mode.	Activates the Dual Watch feature.
[F/W] Key	Activates the "Alternate" key function.	Disables the "Alternate" key function.	Activates the "Memory Write" mode (for memory channel storage).
[HM/RV] Key	Reverses the transmit and receive frequencies while working through a repeater.	Switches operation to the "Home" (favorite frequency) channel.	Activates the "Emergency" Function. See page 31.
[☒] Key	Activates the WIRES™ (Internet Connection) feature.	Recalls the "Weather Broadcast" channels and Short-wave broadcast station channels.	Activates the ARTS™ feature.
[MD] Key	Switches the operating mode.	Activates CTCSS or DCS operation.	Activates the Smart Search™ and Channel Counter features.

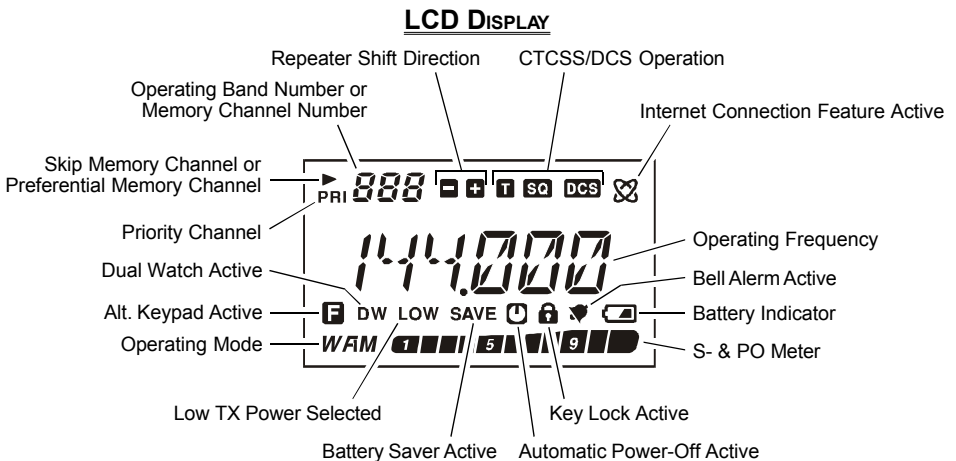

ACCESSORIES & OPTIONS

SUPPLIED ACCESSORIES

FNB-82LI	3.7 V, 1000 mAh Rechargeable Lithium Ion Battery Pack	1
NC-85B, C, or U*	2.5-Hour Charger	1
Belt Clip		1
Antenna		1
Operating Manual		1
Warranty Card		1

AVAILABLE OPTIONS

① CSC-90	Soft Case
② CN-3	BNC-to-SMA Adapter
③ VC-25	VOX Headset
④ MH-34B4B	Speaker/Microphone
⑤ MH-37A4B	Ear piece/Microphone
⑥ CT-27	Cloning Cable
⑦ CT-44	Microphone Adapter
⑧ FNB-82LI	3.7 V, 1000 mAh Rechargeable Lithium Ion Battery Pack
⑨ E-DC-21	DC Cable w/Cigarette-Lighter Adapter
⑩ NC-85B, C, U*	2.5-Hour Charger

※: “B” suffix is for use with 120 VAC, “C” suffix is for use with 230-240 VAC, and “U” suffix is for use with 230 VAC.

Availability of accessories may vary. Some accessories are supplied as standard per local requirements, while others may be unavailable in some regions. Consult your Yaesu dealer for details regarding these and any newly-available options. Connection of any non-Yaesu-approved accessory, should it cause damage, may void the Limited Warranty on this apparatus.

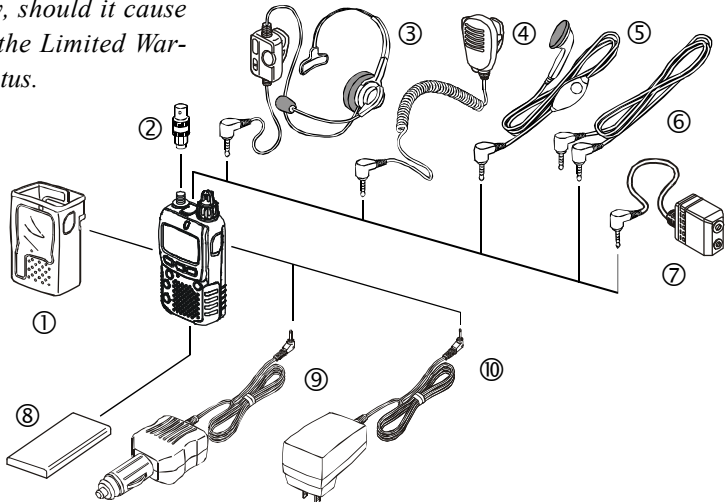

INSTALLATION OF ACCESSORIES

ANTENNA INSTALLATION

The supplied antenna provides good results over the entire frequency range of the transceiver. However, for enhanced base station medium-wave and shortwave reception, you may wish to connect an external (outside) antenna, as the supplied antenna is very small and cannot be expected to provide high performance at these frequencies.

To install the supplied antenna, hold the bottom end of the antenna, then screw it onto the mating connector on the transceiver until it is snug. Do not over-tighten by use of extreme force.

Notes:

- Never transmit without having an antenna connected.
- When installing the supplied antenna, never hold the *upper* part of the antenna while screwing it onto the mating connector on the transceiver.
- If using an external antenna for transmission, ensure that the SWR presented to the transceiver is 1.5:1 or lower, to avoid excessive feedline loss.

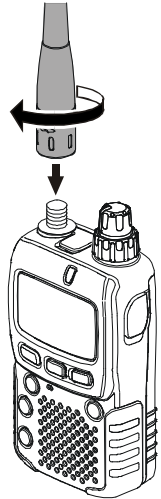

INSTALLATION OF THE SUPPLIED BELT CLIP

1. Remove the dummy cover and its screw from the rear panel of the transceiver. Keep the dummy cover and screw in case you need to replace them in the future.
2. Connect the supplied Belt Clip, along with its mounting screw, to the rear panel.

Do not use the Belt Clip screw to affix the dummy cover!

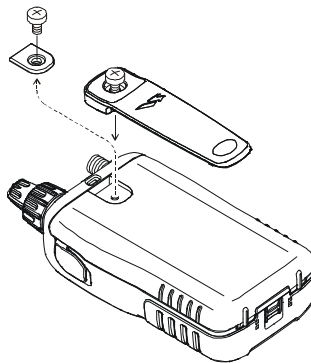

INSTALLATION OF ACCESSORIES

INSTALLATION OF FNB-82LI BATTERY PACK

The **FNB-82LI** is a high-performance Lithium-Ion battery providing high capacity in a *very* compact package. Under normal use, the **FNB-82LI** may be used for approximately 300 charge cycles, after which operating time may be expected to decrease. If you have an old battery pack which is displaying capacity which has become diminished, you should replace the pack with a new one.

Installation of the battery is easy and quick:

- ❑ Slide the Battery Cover Latch to the Unlock position, then slide the Battery Cover toward the bottom to remove it.
- ❑ Install the **FNB-82LI** into the Battery Compartment.
- ❑ Replace the Battery Cover, then slide the Battery Cover Latch to the Lock position.

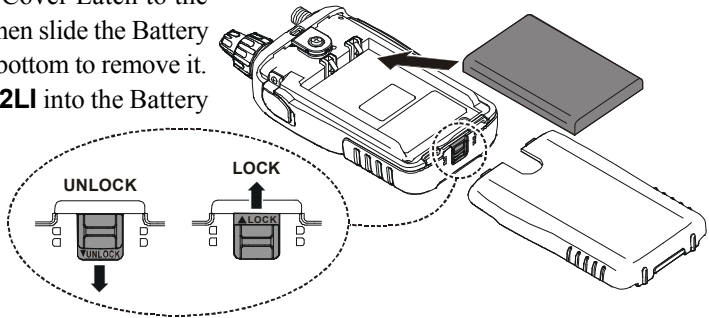

If the battery has never been used, or its charge is depleted, it may be charged by connecting the **NC-85** Battery Charger, as shown in the illustration, to the **EXT DC** jack. If only 12 ~ 16 Volt DC power is available, the optional **E-DC-21** DC Adapter (with its cigarette lighter plug) may also be used for charging the battery.

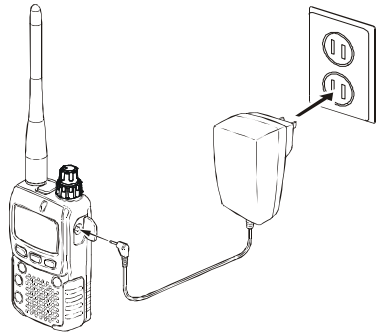

While the battery is being charged, the display will indicate “**CHGNG**” and the **BUSY/TX** indicator will glow red. The S-meter will deflect according to the charging status. When charging is finished, the display will change to indicate “**CHGFUL**” and the **BUSY/TX** indicator will glow green.

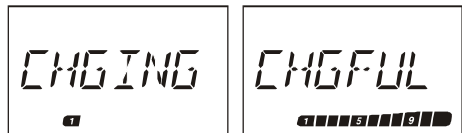

Should you connect the **NC-85** to the **VX-2R** without having the battery inside, the display will indicate “**FL/NBT**” to notify you that you need to install the battery. Similarly, if you connect the **NC-85** to the **VX-2R** when the battery is fully charged, the display will indicate “**CHGFUL**,” the same display that you see at the end of the charge cycle.

The NC-85 is only designed for the charging of the VX-2R’s battery, and is not suitable for other purposes. Please be advised that the NC-85 may contribute noise to TV and radio reception in the immediate vicinity, so we do not recommend its use adjacent to such devices.

INTERFACE OF PACKET TNCs

The **VX-2R** may be used for Packet operation, using the optional **CT-91** microphone adapter (available from your Yaesu dealer) for easy interconnection to commonly-available connectors wired to your TNC. You may also build your own cable, using a four-conductor miniature phone plug, per the diagram below.

The audio level from the receiver to the TNC may be adjusted by using the **VOLUME** knob, as with voice operation. The input level to the **VX-2R** from the TNC should be adjusted at the TNC side; the optimum input voltage is approximately 5 mV at 2000 Ohms.

Be sure to turn the transceiver and TNC off before connecting the cables, so as to prevent voltage spikes from possibly damaging your transceiver.

When you are operating on Packet, switch the Receive Battery Saver OFF, as the “sleep” cycle may “collide” with the beginning of an incoming Packet transmission, causing your TNC not to receive the full data burst. See page 32 for details regarding Battery Saver setup.

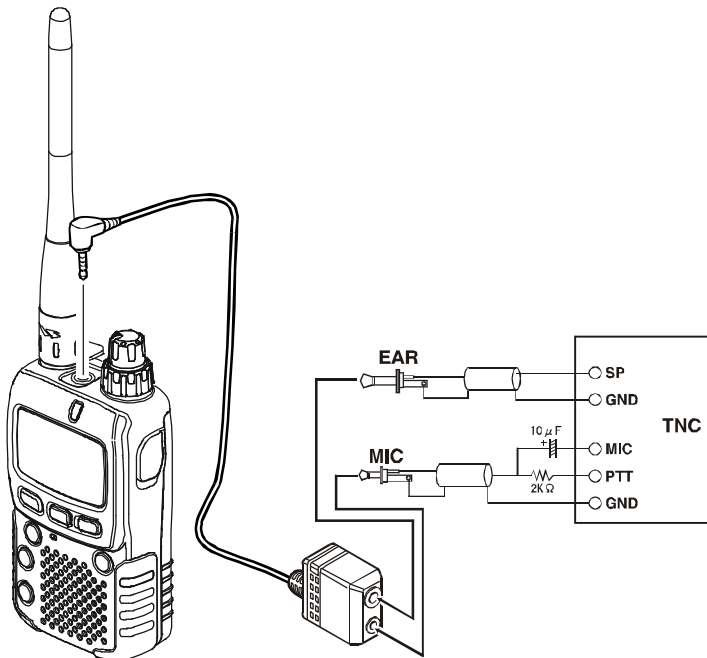

OPERATION



Hi! I'm R. F. Radio, and I'll be helping you along as you learn the many features of the VX-2R. I know you're anxious to get on the air, but I encourage you to read the "Operation" section of this manual as thoroughly as possible, so you'll get the most out of this fantastic new transceiver. Now. . .let's get operating!

SWITCHING POWER ON AND OFF

1. Be sure the Battery Pack is installed, and that the battery is fully charged. Connect the antenna to the top panel **ANTENNA** jack.
2. Press and hold in the **POWER** switch (on the left side of the transceiver) for one second. Two beeps will be heard when the switch has been held long enough, and the current DC supply voltage will be indicated on the display for 2 seconds; if you are using the **FNB-82LI** Battery Pack, the small "Lit" icon at the top of the display confirms that the Lithium-Ion Battery Pack has been detected. After this 2-second interval, the display will resume its normal indication of the operating frequency.
3. To turn the **VX-2R** off, press and hold in the **POWER** switch again for one second.

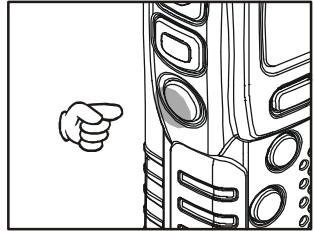

1) If you don't hear the two "Beep" tones when the radio comes on, the Beeper may have been disabled via the Menu system. See page 14, which tells you how to reactivate the Beeper.

2) You can change the Opening Message (DC supply voltage indication) to any desired message (up to 6 characters) via Set Mode Item 30: OPNMSG; see page 68 for details.

ADJUSTING THE VOLUME LEVEL

Rotate the **VOLUME** control (inner knob) to set the desired audio level. Clockwise rotation increases the volume level.

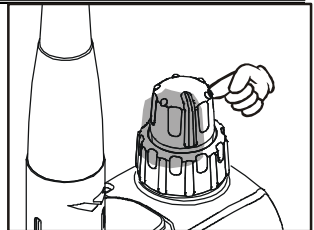

SQUELCH ADJUSTMENT

The **VX-2R**'s Squelch system allows you to mute the background noise when no signal is being received. Not only does the Squelch system make "standby" operation more pleasant, it also significantly reduces battery current consumption.

The Squelch system may be adjusted independently for the FM and Wide-FM (FM Broadcast) modes.

1. Press the [**F/W**] key, then press the **MONI** switch on the left side of the radio. This provides a "Short-cut" to Set Mode Item 41: **SQL**.
2. Now, rotate the **DIAL** knob to set the Squelch so that the background noise is just silenced (typically at a setting of about "1" or "2" for FM, and "2" or "3" for Wide-FM); this is point of maximum sensitivity to weak signals.
3. When you are satisfied with the Squelch threshold setting, press the **PTT** key momentarily to save the new setting and exit to normal operation.



1) A special "RF Squelch" feature is provided on the VX-2R. This feature allows you to set the squelch so that only signals exceeding a certain S-meter level will open the squelch. See page 17 for details.

2) If you're operating in an area of high RF pollution, you may need to consider "Tone Squelch" operation using the built-in CTCSS Decoder. This feature will keep your radio quiet until a call is received from a station sending a carrier which contains a matching (subaudible) CTCSS tone. Or, if your friends have radios equipped with DCS (Digital Coded Squelch) like your VX-2R has, try using that mode for silent monitoring of busy channels.

OPERATION

SELECTING THE OPERATING BAND

The **VX-2R** covers an incredibly wide frequency range, over which a number of different operating modes are used. Therefore, the **VX-2R**'s frequency coverage has been divided into different operating bands, each of which has its own pre-set channel steps and operating modes. You can change the channel steps and operating modes later, if you like (see page 15).

BAND [BAND NUMBER]	FREQUENCY RANGE	
	USA VERSION	EXP VERSION
BC Band [1]	0.5 - 1.8 MHz	0.504 - 1.8 MHz
SW Band [2]	1.8 - 30 MHz	1.8 - 30 MHz
50 MHz Ham Band [3]	30 - 59 MHz	30 - 88 MHz
FM BC Band [4]	59 - 108 MHz	88 - 108 MHz
Air Band [5]	108 - 137 MHz	108 - 137 MHz
144 MHz Ham Band [6]	137 - 174 MHz	137 - 174 MHz
VHF-TV Band [7]	174 - 222 MHz	174 - 222 MHz
Action Band 1 [8]	222 - 420 MHz	222 - 420 MHz
430 MHz Ham Band [9]	420 - 470 MHz	420 - 470 MHz
VHF-TV Band [A]	470 - 800 MHz	470 - 800 MHz
Action Band 2 [b]	803 - 999 MHz	800 - 999 MHz

To Change Operating Bands:

1. Press the **[BAND]** key repetitively. You will see the LCD indication move toward a higher frequency band each time you press the **[BAND]** key.
2. If you wish to move the operating band selection downward (toward lower frequencies), press the **[F/W]** key first, then press the **[BAND]** key.
3. Once you have selected the desired band, you may initiate manual tuning (or scanning) per the discussion in the next chapter.

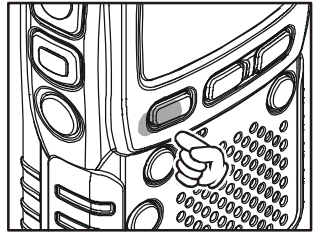

When receiving in the AM Broadcast or Shortwave bands (0.5-30 MHz), we recommend that you connect an external antenna, for improved reception.

FREQUENCY NAVIGATION

The **VX-2R** will initially be operating in the “VFO” mode, a channelized system which allows free tuning throughout the currently-selected operating band.

Two basic frequency navigation methods are available on the **VX-2R**:

1) Tuning Dial (Outer ring of dual control on Top Panel)

Rotation of the **DIAL** allows tuning in the pre-programmed steps established for the current operating band. Clockwise rotation of the **DIAL** causes the **VX-2R** to be tuned toward a higher frequency, while counter-clockwise rotation will lower the operating frequency.

If you press the [**F/W**] key momentarily, then rotate the **DIAL**, frequency steps of 1 MHz will be selected. This feature is extremely useful for making rapid frequency excursions over the wide tuning range of the **VX-2R**.

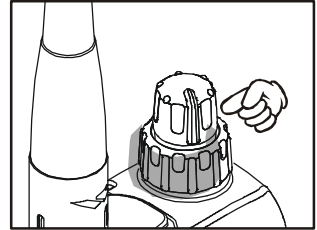

2) Scanning

From the VFO mode, press and hold in the [**BAND**] key for one second, and rotate the **DIAL** knob *while holding in the [BAND] key* to select the bandwidth for the VFO scanner, then release the [**BAND**] key to begin scanning toward a higher frequency. The scanner will stop when it receives a signal strong enough to break through the Squelch threshold. The **VX-2R** will then hold on that frequency according to the setting of the “RESUME” mode (Set Mode Item 31: **RESUME**). See page 47 for details regarding Scan Operatin.

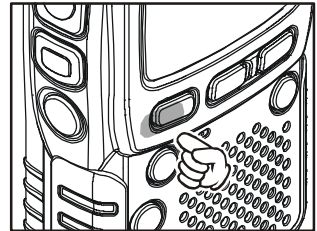

If you wish to reverse the direction of the scan (i.e. toward a lower frequency, instead of a higher frequency), just rotate the **DIAL** one click in the counter-clockwise direction while the **VX-2R** is scanning. The scanning direction will be reversed. To revert to scanning toward a higher frequency once more, rotate the **DIAL** one click clockwise.

Press the **PTT** switch momentarily to cancel the scanning. This only stops the scan; it does not cause transmission to occur.

Notice

The **VX-2R** may receive very strong signals on the Image frequency. If you experience interference that you suspect may be coming in via an “Image” path, you may calculate the possible frequencies using the formulas below. This information may be used in the design of effective countermeasures such as traps, etc.

$$\bigcirc 3.579545 \text{ MHz} \times n$$

$$\bigcirc 11.7 \text{ MHz} \times n$$

(*n* is an integer: 1, 2, 3, ...)

OPERATION

TRANSMISSION

Once you have set up an appropriate frequency inside one of the 144 MHz or 430 MHz Amateur bands on which the **VX-2R** can transmit, you're ready to go on the air! These are the most basic steps; more advanced aspects of transmitter operation will be discussed later.

1. To transmit, press the **PTT** switch, and speak into the front panel microphone (located in the upper left-hand corner of the speaker grille) in a normal voice level. The **BUSY/TX** indicator will glow red during transmission.
2. To return to the receive mode, release the **PTT** switch.
3. During transmission, the relative power level will be indicated on the bar graph at the bottom of the LCD; full scale deflection confirms "High Power" operation, while deflection of two bars indicates "Low Power" operation. Additionally, the "**LOW**" icon will appear at the bottom of the display while operating on the "Low Power" setting.
4. If you're just talking to friends in the immediate area, you'll get much longer battery life by switching to Low Power operation. To do this, press the **[H/L]** key so that the "**LOW**" icon appears at the bottom of the display. And don't forget: always have an antenna connected when you transmit.

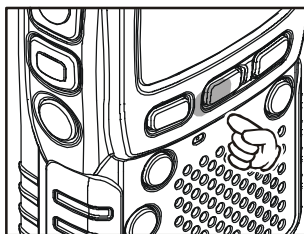
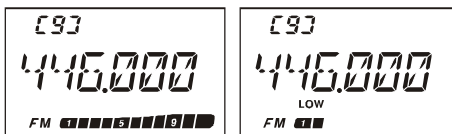
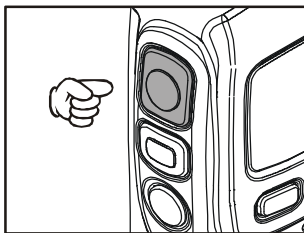

Transmission is possible only on the 144 MHz and 430 MHz bands.



The VX-2R is smart! You can set up Low power on 144 MHz band, while leaving 430 MHz on High power, and the radio will remember the different settings on both bands. And when you store memories, you can store High and Low power settings separately in each memory, so you don't waste battery power when using very close-in repeaters!

BAND	FNB-82LI (3.7 V)	EXT DC (6.0 V)
144 MHz	HI: 1.5 W LOW: 0.1 W	HI: 3.0 W LOW: 0.3 W
430 MHz	HI: 1.0 W LOW: 0.1 W	HI: 2.0 W LOW: 0.3 W

*2) When you are operating on the Low power setting, you can press the **[F/W]** key, when press the **PTT** switch, to cause the **VX-2R** to transmit (temporarily) on High power. After one transmission, the power level will revert to the previously-selected (Low power) setting.*

KEYBOARD LOCKING

In order to prevent accidental frequency change or inadvertent transmission, various aspects of the **VX-2R**'s keys and switches may be locked out. The possible lockout combinations are:

- KEY:** Just the front panel keys are locked out
- DIAL:** Just the top panel **DIAL** is locked out
- K+D:** Both the **DIAL** and Keys are locked out
- PTT:** The **PTT** switch is locked (TX not possible)
- K+P:** Both the keys and **PTT** switch are locked out
- D+P:** Both the **DIAL** and **PTT** switch are locked out
- ALL:** All of the above are locked out

To lock out some or all of the keys:

1. Press and hold in the [**H/L**] key for one second to enter the Set mode.
2. Rotate the **DIAL** knob to select Set Mode Item 25: **LOCK**.
3. Press the [**H/L**] key momentarily to enable adjustment of this Item.
4. Rotate the **DIAL** knob to choose between one of the locking schemes as outlined above.
5. When you have made your selection, press the **PTT** key to save the new setting and return to normal operation.

To activate the locking feature, press the [**F/W**] key, then press and hold in the [**BAND**] key for one second. The “**🔒**” icon will appear on the LCD. To cancel locking, repeat this process.



OPERATION

KEYPAD/LCD ILLUMINATION

Your **VX-2R** includes a reddish illumination lamp which aids in nighttime operation. The red illumination yields clear viewing of the display in a dark environment, with minimal degradation of your night vision. Three options for activating the lamp are provided:

- KEY Mode:** Illuminates the Keypad/LCD for five seconds when any key pressed.
- CONT Mode:** Illuminates the Keypad/LCD continuously.
- OFF Mode:** Disables the Keypad/LCD lamp.

Here is the procedure for setting up the Lamp mode:

1. Press and hold in the **[H/L]** key for one second to enter the Set mode.
2. Rotate the **DIAL** knob to select Set Mode Item 24: **LAMP**.
3. Press the **[H/L]** key momentarily to enable adjustment of this Item.
4. Rotate the **DIAL** knob to select one of the three modes described above.
5. When you have made your choice, press the **PTT** key to save the new setting and return to normal operation.



You may also adjust the Keypad/LCD illumination level and LCD contrast by use of the Set Mode. See page 16 for details.

DISABLING THE KEYPAD BEEPER

If the keypad's Beeper creates an inconvenience (particularly when operating in a quiet room), it may easily be disabled.

1. Press and hold in the **[H/L]** key for one second to enter the Set mode.
2. Rotate the **DIAL** knob to select Set Mode Item 7: **BEEP**.
3. Press the **[H/L]** key momentarily to enable adjustment of this Item.
4. Rotate the **DIAL** knob to change the setting from **ON** to **OFF**.
5. When you have made your selection, press the **PTT** key to save the new setting and return to normal operation.
6. If you wish to re-enable the Beeper, just repeat the above procedure, rotating the **DIAL** knob to select **ON** in step "4" above.

Now that you're mastered the basics of **VX-2R** operation, let's learn more about some of the really neat features.

CHECKING THE BATTERY VOLTAGE

The **VX-2R**'s microprocessor includes programming which will detect the battery type and measure the current battery voltage.

1. Press and hold in the [**H/L**] key for one second to enter the Set mode.
2. Rotate the **DIAL** knob to select Set Mode Item 13: **DC VLT**.
3. Press the [**H/L**] key momentarily to display the battery type and the current DC voltage being supplied.
Lit: **FNB-82LI** is in use.
Edc: An external DC source is in use.
4. Press and hold in the [**H/L**] key for one second to return to normal operation.

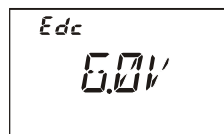
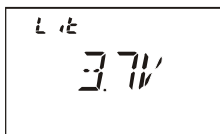

CHANGING THE CHANNEL STEPS

The **VX-2R**'s synthesizer provides the option of utilizing channel steps of 5/9/10/12.5/15/20/25/50/100 kHz per step, as well as an automatic step selection based on the current operating frequency ("AUTO"), any number of which may be important to your operating requirements. The **VX-2R** is set up at the factory in the "AUTO" configuration, which probably is satisfactory for most operation. However, if you need to change the channel step increments, the procedure to do so is very easy.

1. Press and hold in the [**H/L**] key for one second to enter the Set mode.
2. Rotate the **DIAL** knob to select Set Mode Item 43: **STEP**.
3. Press the [**H/L**] key momentarily to enable adjustment of this Item.
4. Rotate the **DIAL** knob to select the new channel step size.
5. When you have made your selection, press the **PTT** key to save the new setting and return to normal operation.



- 1) 9 kHz steps are available only when receiving on the BC band.
- 2) While operating on the BC band, you may only select channel steps of 9 kHz or 10 kHz; the other step selections are disabled.
- 3) 5 kHz steps are not available for use on 250 - 300 MHz, nor above 530 MHz.

ADVANCED OPERATION

CHANGING THE RECEIVING MODE

The **VX-2R** provides for automatic mode changing when the radio is tuned to different operating frequencies. However, should an unusual receiving situation arise in which you need to change other receiving mode, just press the **[MD]** key. The receiving modes available are:

AUTO: Automatic mode setting per default values for the selected frequency range.

N-FM: Narrow-bandwidth FM (used for voice communication)

W-FM: Wide-bandwidth FM (used for high-fidelity broadcasting)

AM: Amplitude Modulation



Unless you have a compelling reason to do so, leave the Automatic Mode Selection feature on so as to save time and trouble when changing bands. If you make a mode change for a particular channel or station, you can always store that one channel into memory, as the mode setting will be memorized along with the frequency information.

DISPLAY DIMMER

The LCD and keypad illumination level may be adjusted using the Set Mode.

1. Press and hold in the **[H/L]** key for one second to enter the Set mode.
2. Rotate the **DIAL** knob to select Set Mode Item 16: **DIMMER**.
3. Press the **[H/L]** key momentarily to enable adjustment of this Set Mode Item.
4. Rotate the **DIAL** knob to adjust the display illumination for a comfortable brightness level. As you make the adjustment, you will be able to see the effects of your changes.
5. When you have completed the adjustment, press the **PTT** key to save the new setting and exit to normal operation.

RF SQUELCH

A special RF Squelch feature is provided on this radio. This feature allows you to set the squelch so that only signals exceeding a certain S-meter level will open the squelch.

To set up the RF squelch circuit for operation, use the following procedure:

1. Press and hold in the **[H/L]** key for one second to enter the Set mode.
2. Rotate the **DIAL** knob to select Set Mode Item 32: **RF SQL**.
3. Press the **[H/L]** key momentarily to enable adjustment of this Item.
4. Rotate the **DIAL** knob to select the desired signal strength level for the squelch threshold (**S1**, **S2**, **S3**, **S4**, **S5**, **S6**, **S8**, **S9+**, or **OFF**).
5. Press the **PTT** key to save the new setting and return to normal operation.

The receiver's squelch will open based on the higher of the levels set by the two squelch systems (Noise Squelch and RF Squelch).

For example:

- 1) If the Noise Squelch (SQL control) is set so that signals at a level of S-3 will open the squelch, but the RF Squelch (Set Mode Item 32) is set to "**S5**," the squelch will only open on signals which are "S-5" or stronger on the S-meter.
- 2) If the RF Squelch is set to "**S3**," but the Noise Squelch is set to a high level which will only pass signals which are Full Scale on the S-meter, the squelch will only open on signals which are Full Scale on the S-meter. In this case, the Noise Squelch overrides the action of the RF Squelch.

ADVANCED OPERATION

REPEATER OPERATION

Repeater stations, usually located on mountaintops or other high locations, provide a dramatic extension of the communication range for low-powered hand-held or mobile transceivers. The **VX-2R** includes a number of features which make repeater operation simple and enjoyable.

Repeater Shifts

Your **VX-2R** has been configured, at the factory, for the repeater shifts customary in your country. For the 144 MHz band shift will be 600 kHz; on the 430 MHz band, the shift may be 1.6 MHz, 7.6 MHz, or 5 MHz (USA version).

Depending on the part of the band in which you are operating, the repeater shift may be either downward (◻) or upward (+), and one of these icons will appear at the top of the LCD when repeater shifts have been enabled.

Automatic Repeater Shift (ARS)

The **VX-2R** provides a convenient Automatic Repeater Shift feature, which causes the appropriate repeater shift to be applied automatically whenever you tune into the designated repeater sub-bands in your country. These sub-bands are shown below.

If the ARS feature does not appear to be working, you may have accidentally disabled it.

To re-enable ARS:

1. Press and hold in the **[H/L]** key for one second to enter the Set mode.
2. Rotate the **DIAL** knob to select Set Mode Item 4: **ARS**.
3. Press the **[H/L]** key momentarily to enable adjustment of this Item.
4. Rotate the **DIAL** knob to select “**ON**” (to enable Automatic Repeater Shift).
5. When you have made your selection, press the **PTT** key to save the new setting and return to normal operation.

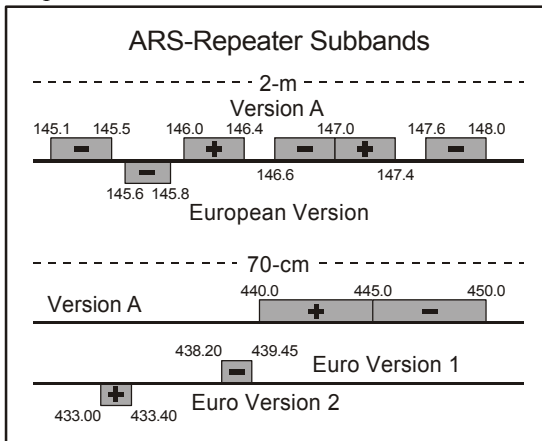

REPEATER OPERATION

Manual Repeater Shift Activation

If the ARS feature has been disabled, or if you need to set a repeater shift direction other than that established by the ARS, you may set the direction of the repeater shift manually.

To do this:

1. Press and hold in the [H/L] key for one second to enter the Set mode.
2. Rotate the **DIAL** knob to select Set Mode Item 33: **RPT**.
3. Press the [H/L] key momentarily to enable adjustment of this Item.
4. Rotate the **DIAL** knob to select the desired shift among “-RPT,” “+RPT,” and “SIMP.”
5. When you have made your selection, press the **PTT** key to save the new setting and return to normal operation.



If you make a change in the shift direction, but still have Automatic Repeater Shift still engaged (see previous section), when you change frequency (by rotating the DIAL knob, for example) the ARS will over-ride your manual setting of the shift direction. Turn ARS off if you do not wish this to happen.

Changing the Default Repeater Shifts

If you travel to a different region, you may need to change the default repeater shift so as to ensure compatibility with local operating requirements.

To do this, follow the procedure below:

1. Set the **VX-2R**'s frequency to the band on which you wish to change the default repeater shift (144 MHz or 430 MHz Ham Band).
2. Press and hold in the [H/L] key for one second to enter the Set mode.
3. Rotate the **DIAL** knob to select Set Mode Item 38: **SHIFT**.
4. Press the [H/L] key momentarily to enable adjustment of this Item.
5. Rotate the **DIAL** knob to select the new repeater shift magnitude.
6. When you have made your selection, press the **PTT** key to save the new setting and return to normal operation.



If you just have one “odd” split that you need to program, don’t change the “default” repeated shifts using this Set Mode Item! Enter the transmit and receive frequencies separately, as shown on page 37.

ADVANCED OPERATION

REPEATER OPERATION

Checking the Repeater Uplink (Input) Frequency

It often is helpful to be able to check the uplink (input) frequency of a repeater, to see if the calling station is within direct (“Simplex”) range.

To do this, just press the **[HM/RV]** key. You’ll notice that the display has shifted to the repeater uplink frequency. Press the **[HM/RV]** key again to cause operation to revert to normal monitoring of the repeater downlink (output) frequency.



The configuration of this key may be set either to “RV” (for checking the input frequency of a repeater), or “HM” (for instant switching to the “Home” channel for the band you are operating on). To change the configuration of this key, use Set Mode Item 22: HM/RV. See page 67.

CTCSS OPERATION

Many repeater systems require that a very-low-frequency audio tone be superimposed on your FM carrier in order to activate the repeater. This helps prevent false activation of the repeater by radar or spurious signals from other transmitters. This tone system, called “CTCSS” (Continuous Tone Coded Squelch System), is included in your **VX-2R**, and is very easy to activate.

CTCSS setup involves two actions: setting the Tone Frequency and then setting of the Tone Mode. These actions are set up by using the [MD] key or Set Mode Items 42: **SQLTYP and 44: **TN FRQ**.**

1. Press the [F/W] key, then press the [MD] key. This provides a “Short-cut” to Set Mode Item 42: **SQLTYP**.
2. Rotate the **DIAL** knob so that “TONE” appears on the display; this activates the CTCSS Encoder, which allows repeater access.
3. Rotation of the **DIAL** knob one more “click” in step “2” above will cause the “T SQL” notation to appear. When “T SQL” is displayed, this means that the Tone SQuelch system is active, which mutes your **VX-2R**’s receiver until it receives a call from another radio sending out a matching CTCSS tone. This can help keep your radio quiet until a specific call is received, which may be helpful while operating in congested.



1) You may notice an additional “DCS” icon appearing while you rotate the DIAL knob in this step. We’ll discuss the Digital Code Squelch system shortly.

2) You may notice “RV TN” indication on the display, this means that the Reverse Tone Squelch system is active, which mutes your VX-2R’s receiver when it receives a call from the radio sending a matched CTCSS tone. The “TSQ” icon will blink on the display when the Reverse Tone Squelch system is activated.

4. When you have made your selection of the CTCSS tone mode, press the **PTT** key to save the new setting.
5. Press and hold in the [H/L] key for one second to enter the Set mode.
6. Rotate the **DIAL** knob to select Set Mode Item 44: **TN FRQ**.
7. Press the [H/L] key momentarily to enable adjustment of the CTCSS frequency.

8. Rotate the **DIAL** knob until the display indicates the Tone Frequency you need to be using (ask the repeater owner/operator if you don’t know the tone frequency).

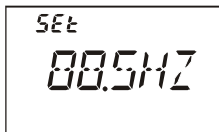

CTCSS TONE FREQUENCY (Hz)					
67.0	69.3	71.9	74.4	77.0	79.7
82.5	85.4	88.5	91.5	94.8	97.4
100.0	103.5	107.2	110.9	114.8	118.8
123.0	127.3	131.8	136.5	141.3	146.2
151.4	156.7	159.8	162.2	165.5	167.9
171.3	173.8	177.3	179.9	183.5	186.2
189.9	192.8	196.6	199.5	203.5	206.5
210.7	218.1	225.7	229.1	233.6	241.8
250.3	254.1	–	–	–	–

ADVANCED OPERATION

CTCSS OPERATION

- When you have made your selection, press the [H/L] key momentarily, then press the PTT switch, to save the new settings and exit to normal operation. This is different than the usual method of restoring normal operation, and it applies only to the configuration of the CTCSS/DCS frequencies.



Your repeater may or may not re-transmit a CTCSS tone - some systems just use CTCSS to control access to the repeater, but don't pass it along when transmitting. If the S-Meter deflects, but the VX-2R is not passing audio, repeat steps "1" through "4" above, but rotate the DIAL so that "TSQ" disappears - this will allow you to hear all traffic on the channel being received.

DCS OPERATION

Another form of tone access control is Digital Code Squelch, or DCS. It is a newer, more advanced tone system which generally provides more immunity from false paging than does CTCSS. The DCS Encoder/Decoder is built into your VX-2R, and operation is very similar to that just described for CTCSS. Your repeater system may be configured for DCS; if not, DCS is frequently quite useful in Simplex operation if your friend(s) use transceivers equipped with this advanced feature.

Just as in CTCSS operation, DCS requires that you set the Tone Mode to DCS and that you select a tone code.

- Press the [F/W] key, then press the [MD] key. This provides a "Short-cut" to Set Mode Item 42: **SQLTYP**.
- Press the [H/L] key momentarily to enable adjustment of this Item.
- Rotate the **DIAL** knob until "**DCS**" appears on the display; this activates the DCS Encoder/Decoder.
- Press the **PTT** key to save the new setting.
- Press and hold the [H/L] key for one second to enter the Set mode.
- Rotate the **DIAL** knob to select Set Mode Item 14: **DCS CD**.
- Press the [H/L] key momentarily to enable the adjustment of the DCS code.
- Rotate the **DIAL** knob to select the desired DCS Code (a three-digit number). Ask the repeater owner/operator if you don't know DCS Code; if you are working simplex, just set up the DCS Code to be

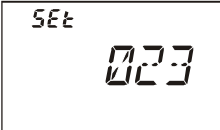

DCS CODE									
023	025	026	031	032	036	043	047	051	053
054	065	071	072	073	074	114	115	116	122
125	131	132	134	143	145	152	155	156	162
165	172	174	205	212	223	225	226	243	244
245	246	251	252	255	261	263	265	266	271
274	306	311	315	325	331	332	343	346	351
356	364	365	371	411	412	413	423	431	432
445	446	452	454	455	462	464	465	466	503
506	516	523	526	532	546	565	606	612	624
627	631	632	654	662	664	703	712	723	731
732	734	743	754	-	-	-	-	-	-

DCS OPERATION

the same as that used by your friend(s).

- When you have made your selection, press the **[H/L]** key momentarily, then press the **PTT** switch to save the new settings and exit to normal operation.



Remember that the DCS is an Encode/Decode system, so your receiver will remain muted until a matching DCS code is received on an incoming transmission. Switch the DCS off when you're just tuning around the band!

TONE SEARCH SCANNING

In operating situations where you don't know the CTCSS or DCS tone being used by another station or stations, you can command the radio to listen to the incoming signal and scan in search of the tone being used. Two things must be remembered in this regard:

- You must be sure that your repeater uses the same tone type (CTCSS vs. DCS).
- Some repeaters do not pass the CTCSS tone; you may have to listen to the station(s) transmitting on the repeater uplink (input) frequency in order to allow Tone Search Scanning to work.

To scan for the tone in use:

- Set the radio up for either CTCSS or DCS Decoder operation (see the previous discussions). In the case of CTCSS, "**T SQ**" will appear on the display; in the case of DCS, "**DCS**" will appear on the display.
- Press and hold in the **[H/L]** key for one second to enter the Set mode.
- Rotate the **DIAL** knob to select Set Mode Item 44: **TN FRQ** when TONE SQL is selected, or Set Mode Item 14: **DCS CD** during DCS operation.
- Press the **[H/L]** key momentarily to enable adjustment of the selected Set Mode Item.
- Press and hold in the **[BAND]** key for one second, appear "**T SRCH**" (for CTCSS Tone Search) or "**D SRCH**" (for DCS Tone Search) on the display, then release the **[BAND]** key to start scanning for the incoming CTCSS or DCS tone/code.
- When the radio detects the correct tone or code, it will halt on that tone/code, and audio will be allowed to pass. Press the **[BAND]** key to lock in that tone/code, then press **PTT** to exit to normal operation.

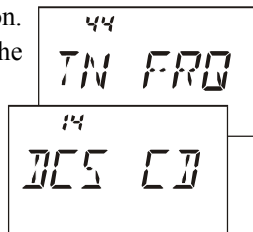

If the Tone Scan feature does not detect a tone or code, it will continue to scan indefinitely. When this happens, it may be that the other station is not sending any tone. You can press the PTT switch to halt the scan at any time.

You also can press the **MONI** key during Tone Scanning to listen to the (muted) signal from the other station. When you release the **MONI** key, Tone Scanning will resume after about a second.

ADVANCED OPERATION

CTCSS/DCS BELL OPERATION

During CTCSS Decode or DCS operation, you may set up the **VX-2R** such that a ringing “bell” sound alerts you to the fact that a call is coming in. Here is the procedure for activating the CTCSS/DCS Bell:

1. Set the transceiver up for CTCSS Decode (“Tone Squelch”) or DCS operation, as described previously.
2. Adjust the operating frequency to the desired channel.
3. Press and hold in the **[H/L]** key for one second to enter the Set mode.
4. Rotate the **DIAL** knob to select Set Mode Item 8: **BELL**.
5. Press the **[H/L]** key momentarily to enable adjustment of this Set Mode Item.
6. Rotate the **DIAL** knob to set the desired number of rings of the Bell. The available choices are **1**, **3**, **5**, or **8** rings, **CONT** (continuous ringing), or **OFF**.
7. Press the **PTT** key momentarily to save the new setting and exit to normal operation.

When you are called by a station whose transceiver is sending a CTCSS tone or DCS code which matches that set into your Decoder, the Bell will ring in accordance with this programming.

SPLIT TONE OPERATION

The **VX-2R** can be operated in a Split Tone configuration via the Set mode.

1. Press and hold in the **[H/L]** key for one second to enter the Set mode.
2. Rotate the **DIAL** knob to select Set Mode Item 40: **SPLIT**.
3. Press the **[H/L]** key momentarily to enable adjustment of this Set Mode Item.
4. Rotate the **DIAL** knob to select **ON** (to enable the Split Tone feature).
5. Press the **PTT** key momentarily to save the new setting and exit to normal operation.

When the Split Tone feature is activated, you can see the following additional parameters after the “**RV TN**” parameter while selecting the Set Mode Item 42: **SQLTYP**:

D CODE: DCS Encode only

(the “**DCS**” icon will blink during operation)

T DCS: Encodes a CTCSS Tone and Decodes a DCS code

(the “**T**” icon will blink and the “**DCS**” icon will appear during operation)

D TONE: Encodes a DCS code and Decodes a CTCSS Tone

(the “**T SQ**” icon will appear and the “**DCS**” icon will blink during operation)

Select the desired operating mode, from the selections shown above, within Set Mode Item 42.

TONE CALLING (1750 Hz)

If the repeaters in your country require a 1750-Hz burst tone for access (typically in Europe), you can set the **MONI** key to serve as a “Tone Call” switch instead. To change the configuration of this switch, we again use the Set Mode to help us.

1. Press and hold in the [**H/L**] key for one second to enter the Set mode.
2. Rotate the **DIAL** knob to select Set Mode Item 26: **M/T-CL**.
3. Press the [**H/L**] key momentarily to enable adjustment of this Set Mode Item.
4. Rotate the **DIAL** knob to select “**T-CALL**” on the display.
5. Press the **PTT** key to save the new setting and exit to normal operation.

To access a repeater, press and hold in the **MONI** key for the amount of time specified by the repeater owner/operator. The transmitter will automatically be activated, and a 1750-Hz audio tone will be superimposed on the carrier. Once access to the repeater has been gained, you may release the **MONI** key, and use the **PTT** key for activating the transmitter thereafter.

ADVANCED OPERATION

ARTS™ (AUTOMATIC RANGE TRANSPONDER SYSTEM)

The ARTS™ feature uses DCS signaling to inform both parties when you and another ARTS™-equipped station are within communications range. This may be particularly useful during Search-and Rescue situations, where it is important to stay in contact with other members of your group.

Both stations must set up their DCS codes to the same code number, then activate their ARTS™ feature using the command appropriate for their radio. Alert ringers may be activated, if desired.

Whenever you push the **PTT**, or every 25 (or 15) seconds after ARTS™ is activated, your radio will transmit a signal which includes a (subaudible) DCS signal for about 1 second. If the other radio is in range, the beeper will sound (if enabled) and the display will show “**IN RNG**” as opposed to the out of range display “**OUTRNG**” in which ARTS™ operation begins.

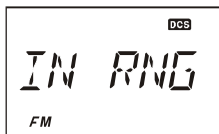

Whether you talk or not, the polling every 15 or 25 seconds will continue until you de-activate ARTS™. Every 10 minutes, moreover, you can have your radio transmit your callsign via CW, so as to comply with identification requirements. When ARTS™ is de-activated, DCS will also be deactivated (if you were not using it previously in non-ARTS™ operation).



If you move out of range for more than one minute (four pollings), your radio will sense that no signal has been received, three beeps will sound, and the display will revert to “**OUTRNG**.” If you move back into range, your radio will again beep, and the display will change back to the “**IN RNG**” indication.

During ARTS™ operation, your operating frequency will continue to be displayed, but no changes may be made to it or other settings; you must terminate ARTS™ in order to resume normal operation. This is a safety feature designed to prevent accidental loss of contact due to channel change, etc.

Basic ARTS™ Setup and Operation

1. Set your radio and the other radio(s) to the same DCS code number, per the discussion on page 22.
2. Press and hold in the [⊗] key for one second. You will observe the “**OUTRNG**” display on the LCD below the operating frequency. ARTS™ operation has now commenced.
3. Every 25 seconds, your radio will transmit a “polling” call to the other station. When that station responds with its own ARTS™ polling signal, the display will change to “**IN RNG**” to confirm that the other station’s polling code was received in response to yours.

ARTS™ (AUTOMATIC RANGE TRANSPONDER SYSTEM)

4. Press and hold in the [⊗] key for one second to exit ARTS™ operation and resume normal functioning of the transceiver.



ARTS™ won't work if you have used the Lock feature to disable the PTT!

ARTS™ Polling Time Options

The ARTS™ feature may be programmed to poll every 25 seconds (default value) or 15 seconds. The default value provides maximum battery conservation, because the polling signal is sent out less frequently. To change the polling interval:

1. Press and hold in the [H/L] key for one second to enter the Set mode.
2. Rotate the **DIAL** knob to select Set Mode Item 3: **AR INT**.
3. Press the [H/L] key momentarily to enable adjustment of this Set Mode Item.
4. Rotate the **DIAL** knob to select the desired polling interval (15 or 25 seconds).
5. When you have made your selection, press the **PTT** key to save the new setting and exit to normal operation.

ARTS™ Alert Beep Options

The ARTS™ feature allows two kinds of alert beeps (with the additional option of turning them off), so as to alert you to the current status of ARTS™ operation. Depending on your location and the potential annoyance associated with frequent beeps, you may choose the Beep mode which best suits your needs. The choices are:

- IN RNG:** The beeps are issued only when the radio first confirms that you are within range, but does not re-confirm with beeps thereafter.
- ALW AYS:** Every time a polling transmission is received from the other station, the alert beeps will be heard.
- OFF:** No alert beeps will be heard; you must look at the display to confirm current ARTS™ status.

To set the ARTS™ Beep mode, use the following procedure:

1. Press and hold in the [H/L] key for one second to enter the Set mode.
2. Rotate the **DIAL** knob to select Set Mode Item 2: **AR BEP**.
3. Press the [H/L] key momentarily to enable adjustment of this Set Mode Item.
4. Rotate the **DIAL** knob to select the desired ARTS™ Beep mode (see above).
5. When you have made your selection, press the **PTT** key to save the new setting and exit to normal operation.

ADVANCED OPERATION

ARTS™ (AUTOMATIC RANGE TRANSPONDER SYSTEM)

CW Identifier Setup

The ARTS™ feature includes a CW identifier, as discussed previously. Every ten minutes during ARTS™ operation, the radio can be instructed to send “**DE (your callsign) K**” if this feature is enabled. The callsign field may contain up to 16 characters.

Here’s how to program the CW Identifier:

1. Press and hold in the [H/L] key for one second to enter the Set mode.
2. Rotate the **DIAL** knob to select Set Mode Item 12: **CW ID**.
3. Press the [H/L] key momentarily to enable adjustment of this Set Mode Item.
4. Rotate the **DIAL** knob to set this Item to “**ON**” (to enable the CW ID function).
5. Press the [V/M] key momentarily to display the previously stored callsign.
6. Press the [HM/RV] key momentarily to *clear* any previous callsign.
7. Rotate the **DIAL** knob to select the first letter/number of your callsign, then press the [V/M] key momentarily to save the first letter/number and move on to the next character.
8. Repeat the previous step, as many times as necessary, to complete your callsign. Note that the “slant bar” (—••—•) is among the available characters, should you be a “portable” station.
9. If you mistake, press the [BAND] key to back-space the cursor, then re-enter the correct letter/number.
10. Press the [HM/RV] key to delete all data after the cursor that may have been previously stored erroneously.
11. When you have entered your entire callsign, press the [H/L] key momentarily to confirm the callsign, then press the **PTT** key to save the settings and exit to normal operation.

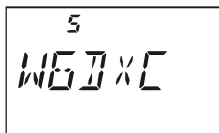
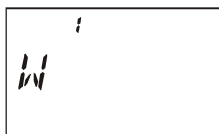
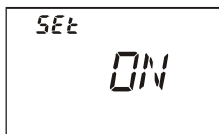
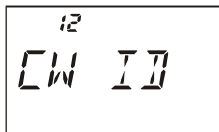

You may check your work by monitoring the entered callsign. To do this, repeat steps 1- 3 above, then press the [F/W] key.

DTMF OPERATION

Despite the lack of a DTMF keypad, you can still transmit DTMF tones with the **VX-2R** for repeater control or autopatch use.

Manual DTMF Tone Generation

1. Press and hold the **[H/L]** key for one second to enter the Set mode.
2. Rotate the **DIAL** knob to select Set Mode Item 17: **DTMF**.
3. Press the **[H/L]** key to enable adjustment of this Set Mode Item.
4. Rotate the **DIAL** knob to select “**MANUAL**.”
5. Press the **PTT** switch to return to normal display.
6. Hold the **PTT** switch in to continue transmitting during the following steps.
 - A. Press the **[H/L]** key momentarily.
 - B. Rotate the **DIAL** knob to select the number to be sent, then press the **[H/L]** key momentarily to send the number.
 - C. Repeat step B as many times as needed until you have completed the number string.
 - D. Release the **PTT** switch.



The DTMF “” code is displayed as “E,” and the DTMF code “#” is displayed as “F” on the display.*

DTMF Autodialer

Nine DTMF Autodial memories are provided, allowing you to store telephone numbers for autopatch use. You can also store short autopatch or Internet-link access code streams so as to avoid having to send them manually.

Here is the DTMF Autodial storage procedure:

1. Press and hold in the **[H/L]** key for one second to enter the Set mode.
2. Rotate the **DIAL** knob to select Set Mode Item 18: **DTMF S**.
3. Press the **[H/L]** key to enable adjustment of this Set Mode Item.
4. Rotate the **DIAL** knob to select the DTMF Memory register into which you wish to store this DTMF string.
5. Press the **[V/M]** key to begin DTMF Memory entry into the selected register. The first digit location will blink.
6. Rotate the **DIAL** knob to select the first digit of the DTMF string. Selectable entries are 1 - 9, and A - F, with E and F representing DTMF “*” and “#” tones respectively.
7. Press the **[V/M]** key momentarily to accept the first digit and move on to the second digit of the DTMF string.
8. Repeat the previous steps until you have completed the tele-

ADVANCED OPERATION

DTMF OPERATION

phone number string.

9. If you make a mistake, press the [**BAND**] key to back-space the cursor, then re-enter the correct digit.
10. Press the [**H/L**] key momentarily to store the string into the DTMF memory.
11. To store another number, press the [**H/L**] key again, then rotate the **DIAL** knob to select another DTMF Memory register, and repeat this procedure.
12. When finished storing DTMF Memories, press the **PTT** switch to return to normal display.

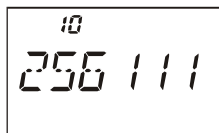

To send the telephone number:

1. Press and hold in the [**H/L**] key for one second to enter the Set mode.
2. Rotate the **DIAL** knob to select Set Mode Item 17: **DTMF**.
3. Press the [**H/L**] key to enable adjustment of this Set Mode Item.
4. Rotate the **DIAL** knob to set this Item to “**AUTO**.”
5. Press the **PTT** switch to return to normal display.
6. Hold the **PTT** switch to continue transmitting during following steps.
 - A. Press the [**H/L**] key momentarily.
 - B. Rotate the **DIAL** knob to select the DTMF Memory register (CH 1 through CH 9) you wish to send.
 - C. Press the [**H/L**] key momentarily to transmit the tone string. Once the string begins, you may release the **PTT** key, as the transmitter will be held “on the air” until the DTMF string is completed.

EMERGENCY CHANNEL OPERATION

The **VX-2R** includes an “Emergency” feature which may be useful if you have someone monitoring on the same frequency as your transceiver’s UHF “Home” channel. See page 388 for details on setting the Home channel.

The “Emergency” feature is activated by pressing and holding in the [**HM/RV**] key for one second.

When this is done, (A) the radio is placed on the UHF amateur band Home channel, (B) it emits a loud “Alarm” sound (the volume is controlled by the **VOLUME** knob), (C) it flashes the **BUSY/TX** indicator in white, (D) if you press the **PTT** key, you will disable the Emergency feature temporarily; you can then transmit on the UHF Home channel, and (E) two seconds after the **PTT** release, the Emergency feature will resume.

To disable the “Emergency” feature, press and hold the [**HM/RV**] key for one second or turn the radio Off by pressing and holding in the **POWER** switch for one second.

Use this feature if you are out for a walk and want a quick way of alerting a family member as to a dangerous situation. The alarm sound may discourage an attacker and allow you to escape.



- 1) Be sure to arrange with a friend or family member to be monitoring on the same frequency, as there will be no identification sent via the Emergency alarm sound. And do not transmit the alarm tone except in a true emergency!*
- 2) The TX/BUSY indicator may be changed to another function via Set Mode Item 20: EMG S; see page 66.*

ATT (FRONT END ATTENUATOR)

The attenuator will reduce all signals (and noise) by 10 dB, and it may be used to make reception more pleasant under extremely crowded conditions. This feature is not available on the Wide FM mode.

1. Press and hold in the [**H/L**] key for one second to enter the Set mode.
2. Rotate the **DIAL** knob to select Set Mode Item 5: **ATT**.
3. Press the [**H/L**] key momentarily to enable adjustment of this Set Mode Item.
4. Rotate the **DIAL** knob to change the setting from **OFF** to **ON**.
5. When you have made your selection, press the **PTT** key to save the new setting and exit to normal operation.
6. If you wish to disable the attenuator, just repeat the above procedure, rotating the **DIAL** knob to select **OFF** in step “4” above.



When the attenuator is activated, the Operating Mode icon (AM or FM) will blink on the display.

ADVANCED OPERATION

RECEIVE BATTERY SAVER SETUP

An important feature of the **VX-2R** is its Receive Battery Saver, which “puts the radio to sleep” for a time interval, periodically “waking it up” to check for activity. If somebody is talking on the channel, the **VX-2R** will remain in the “active” mode, then resume its “sleep” cycles. This feature significantly reduces quiescent battery drain, and you may change the amount of “sleep” time between activity checks using the Set Mode:

1. Press and hold in the **[H/L]** key for one second to enter the Set mode.
2. Rotate the **DIAL** knob to select Set Mode Item 35: **RXSAVE**.
3. Press the **[H/L]** key momentarily to enable adjustment of this Set Mode Item.
4. Rotate the **DIAL** knob to select the desired “sleep” duration. The selections available are 200 ms, 300 ms, 500 ms, 1 second, 2 seconds, or OFF. The default value is 200 ms.
5. When you have made your selection, press the **PTT** key to save the new setting and exit to normal operation.



When you are operating on Packet, switch the Receive Battery Saver OFF, as the sleep cycle may “collide” with the beginning of an incoming Packet transmission, causing your TNC not to receive the full data burst.

TX BATTERY SAVER

The **VX-2R** also includes a useful Transmit Battery Saver, which will automatically lower the power output level when the last signal received was very strong. For example, when you are in the immediate vicinity of a repeater station, there generally is no reason to use the High Power output in order to achieve full-quieting access to the repeater. With the Transmit Battery Saver, the automatic selection of Low Power operation conserves battery drain significantly.

To activate the Transmit Battery Saver:

1. Press and hold in the **[H/L]** key for one second to enter the Set mode.
2. Rotate the **DIAL** knob to select Set Mode Item 46: **TXSAVE**.
3. Press the **[H/L]** key momentarily to enable adjustment of this Set Mode Item.
4. Rotate the **DIAL** knob to set this Set Mode Item to “**ON**” (thus activating the Transmit Battery Saver).
5. When you have made your selection, press the **PTT** key to save the new setting and exit to normal operation.

DISABLING THE BUSY INDICATOR

Further battery conservation may be accomplished by disabling the BUSY indicator while receiving a signal. Use the following procedure:

1. Press and hold in the [H/L] key for one second to enter the Set mode.
2. Rotate the **DIAL** knob to select Set Mode Item 9: **BSYLED**.
3. Press the [H/L] key momentarily to enable adjustment of this Set Mode Item.
4. Rotate the **DIAL** knob to set this Set Mode Item to “OFF” (thus disabling the BUSY lamp).
5. When you have made your selection, press the **PTT** key to save the new setting and exit to normal operation.

AUTOMATIC POWER-OFF (APO) FEATURE

The APO feature helps conserve battery life by automatically turning the radio off after a user-defined period of time within which there has been no dial or key activity. The available selections for the time before power-off are 0.5/1/3/5/8 hours, as well as APO Off. The default condition for the APO is OFF, and here is the procedure for activating it:

1. Press and hold in the [H/L] key for one second to enter the Set mode.
2. Rotate the **DIAL** knob to select Set Mode Item 1: **APO**.
3. Press the [H/L] key momentarily to enable adjustment of this Set Mode Item.
4. Rotate the **DIAL** knob to select the desired time period after which the radio will automatically shut down.
5. When you have made your selection, press the **PTT** key to save the new setting and exit to normal operation.

When the APO is activated, the “⏻” icon will appear at the center bottom on the LCD. If there is no action by you within the time interval programmed, the microprocessor will shut down the radio automatically.

Just press and hold in the **POWER** switch for one second to turn the transceiver back on after an APO shutdown, as usual.

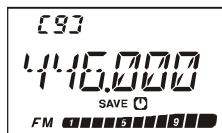

ADVANCED OPERATION

TRANSMITTER TIME-OUT TIMER (TOT)

The TOT feature provides a safety switch which limits transmission time to a pre-programmed value. This will promote battery conservation by not allowing you to make excessively-long transmissions, and in the event of a stuck **PTT** switch (perhaps if the radio or a Speaker/Mic is wedged between car seats) it can prevent interference to other users as well as battery depletion. As configured at the factory the TOT feature is set to OFF, and here is the procedure for activating it:

1. Press and hold in the **[H/L]** key for one second to enter the Set mode.
2. Rotate the **DIAL** knob to select Set Mode Item 45: **TOT**.
3. Press the **[H/L]** key momentarily to enable adjustment of this Set Mode Item.
4. Rotate the **DIAL** knob to set the Time-Out Timer to the desired “Maximum TX” time (1 minute, 3 minutes, 5 minutes, or 10 minutes).
5. When you have made your selection, press the **PTT** key to save the new setting and exit to normal operation.



- 1) When your transmission time is within 10 seconds of the Time-Out Timer expiration, an Alert bell will provide an audible warning from the speaker.*
- 2) Since brief transmissions are the mark of a good operator, try setting up your radio's TOT feature for a maximum transmission time of one minute. This will significantly improve battery life, too!*

BUSY CHANNEL LOCK-OUT (BCLO)

The BCLO feature prevents the radio's transmitter from being activated if a signal strong enough to break through the “noise” squelch is present. On a frequency where stations using different CTCSS or DCS codes may be active, BCLO prevents you from disrupting their communications accidentally (because your radio may be muted by its own Tone Decoder). The default setting for the BCLO is OFF, and here is how to change that setting:

1. Press and hold in the **[H/L]** key for one second to enter the Set mode.
2. Rotate the **DIAL** knob to select Set Mode Item 6: **BCLO**.
3. Press the **[H/L]** key momentarily to enable adjustment of this Set Mode Item.
4. Rotate the **DIAL** knob to set this Set Mode Item to “**ON**” (thus activating the BCLO feature).
5. When you have made your selection, press the **PTT** key to save the new setting and exit to normal operation.

CHANGING THE TX DEVIATION LEVEL

In many areas of the world, channel congestion has required that operating channels be closely spaced. In such operating environments, it often is required that operators use reduced deviation levels, so as to reduce the potential for interference to users on adjacent channels. The **VX-2R** includes a simple method of accomplishing this:

1. Press and hold in the [**H/L**] key for one second to enter the Set mode.
2. Rotate the **DIAL** knob to select the Set Mode Item 21: **HLFDEV**.
3. Press the [**H/L**] key momentarily to enable adjustment of this Set Mode Item.
4. Rotate the **DIAL** knob to set this Set Mode Item to “**ON**.” In this configuration (HALF DEVIATION active), the transmitter’s deviation will be approximately ± 2.5 kHz.
5. When you have made your selection, press the **PTT** key to save the new setting and exit to normal operation.



The “normal” setting for the deviation (when this Menu Item is set to OFF) is ± 5 kHz.

MEMORY MODE

The **VX-2R** provides a wide variety of memory system resources. These include:

- ❑ “Regular” Memory Channels, which include:
 - 900 “Standard” memory channels, numbered “1” through “900.”
 - 100 “Frequency Skip Memories,” numbered “901” through “999” and “000.”
 - 11 “Home” channels, providing storage and quick recall of one prime frequency on each operating band.
 - 50 sets of band-edge memories, also known as “Programmable Memory Scan” channels, labeled “L01/U01” through “L50/U50.”
 - 20 Memory Banks, labeled “b 1” through “b20.” Each Memory Bank can be assigned up to 100 channels from the “regular” and “special” memory channels.
- ❑ Special Memory Channels, which include:
 - 10 “Weather Broadcast” Channels.
 - 280 VHF Marine Channels
 - 89 popular Short-wave Broadcast Station Memory Channels.

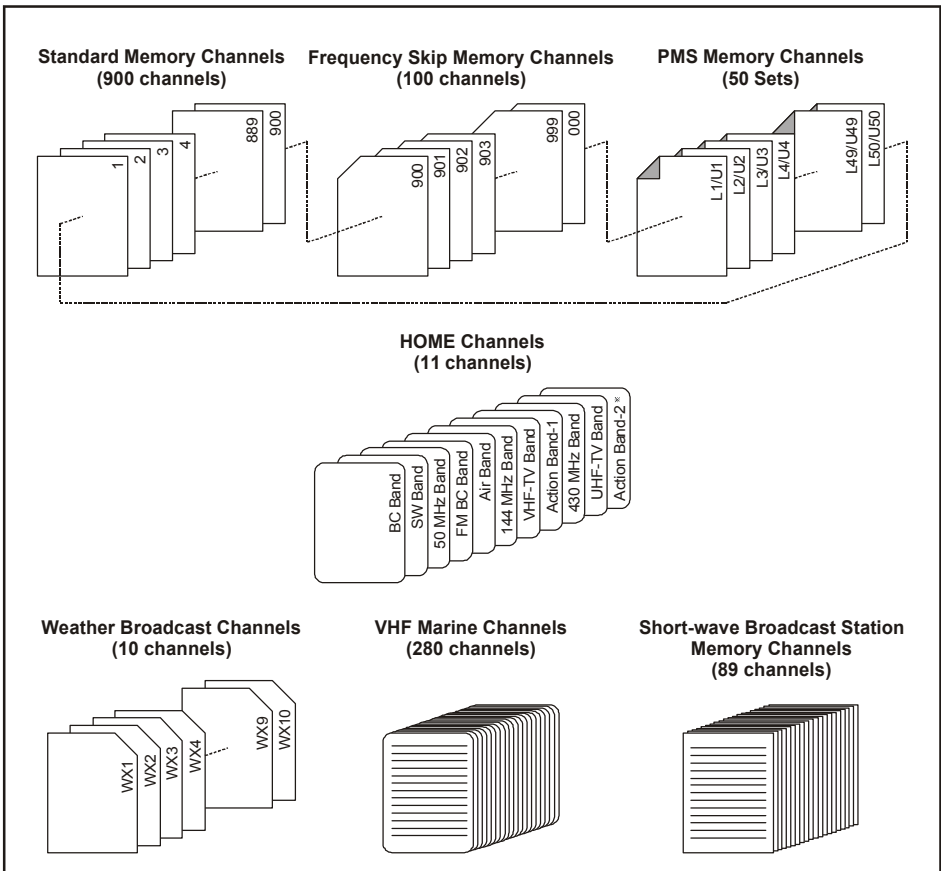

REGULAR MEMORY CHANNEL OPERATION

Memory Storage

1. Select the desired frequency, while operating in the VFO mode. Be sure to set up any desired CTCSS or DCS tones, as well as any desired repeater offset. The power level may also be set at this time, if you wish to store it.
2. Press and hold in the **[F/W]** key for one second.
3. Within five seconds of releasing the **[F/W]** key, you need to make a decision regarding channel storage. The microprocessor will automatically select the next-available “free” channel (a memory register on which no data has been stored), so you may not wish to make any change; if this is the case, proceed to step 4. If you wish to select a different channel number into which to store the data, rotate the **DIAL** knob to select the desired memory channel. You may jump 100 memory channels, if you’re in a hurry (101 → 201 → 301 ...), by pressing the **[H/L]** key (multiple times, if necessary). Any channel that you see with a blinking channel number currently has no data written on it (i.e. the channel is “free”).
4. Press the **[F/W]** key once more to store the frequency into memory.
5. You still will be operating in the “VFO” mode, so you may now enter other frequencies, and store them into additional memory locations, by repeating the above process.



You may change the automatic memory channel selection feature to select the “next-highest memory channel above the last-stored memory channel” instead of the “next-available ‘free’ channel” via the Set Mode Item 27: MW

MODE; see page 68.

Storing Independent Transmit Frequencies (“Odd Splits”)

All memories can store an independent transmit frequency, for operation on repeaters with non-standard shift. To do this:

1. Store the receive frequency using the method already described under MEMORY STORAGE (it doesn’t matter if a repeater offset is active).
2. Turn to the desired transmit frequency, then press and hold in the **[F/W]** key for one second.
3. Within five seconds of releasing the **[F/W]** key, rotate the **DIAL** knob to select the same memory channel number as used in step “1” above.
4. *Press and hold in the PTT switch*, then press the **[F/W]** key once more momentarily *while holding* the **PTT** switch in (this does not key the transmitter).



*Whenever you recall a memory which contains independently-stored transmit and receive frequencies, the “**[M] [S]**” indication will appear in the display.*

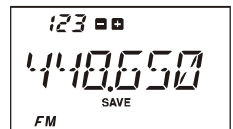

MEMORY MODE

REGULAR MEMORY CHANNEL OPERATION

Memory Recall

1. While operating in the VFO mode, press the [VM] key to enter the Memory mode.
2. Rotate the **DIAL** knob to select the desired channel.
3. To return to the VFO mode, press the [VM] key.



HOME Channel Memory

A special one-touch “HOME” channel is available for each of operating bands, to allow quick recall of a favorite operating frequency /on each band.

Home Channel storage is simple to accomplish:

1. Select the desired frequency, while operating in the VFO mode. Be sure to set up any desired CTCSS or DCS tones, as well as any desired repeater offset. The power level may also be set at this time, if you wish to store it.
2. Press and hold in the [FW] key for one second.
3. While the memory channel number is blinking, just press the [HM/RV] key. The frequency and other data (if any) will now be stored in the special HOME channel register.
4. You may repeat this process on the other operating bands.
5. To recall the HOME channel, press and hold in the [HM/RV] key for one second while operating either in the VFO or MR mode.

DEFAULT HOME CHANNELS

BAND	FREQUENCY	
	USA VERSION	EXP VERSION
BC Band	0.540 MHz	0.540 MHz
SW Band	1.800 MHz	1.800 MHz
50 MHz Ham Band	30.000 MHz	30.000 MHz
FM BC Band	59.000 MHz	88.000 MHz
Air Band	108.000 MHz	108.000 MHz
144 MHz Ham Band	146.520 MHz	144.000 MHz
VHF-TV Band	174.000 MHz	174.000 MHz
Action Band 1	230.000 MHz	230.000 MHz
430 MHz Ham Band	446.000 MHz	430.000 MHz
UHF-TV Band	470.000 MHz	470.000 MHz
Action Band 2	860.000 MHz	860.000 MHz



USA Version



EXP Version



The UHF HOME channel is the one used during “Emergency” operation. See page 31 for details regarding this feature.

REGULAR MEMORY CHANNEL OPERATION

Labeling Memories

You may wish to append an alpha-numeric “Tag” (label) to a memory or memories, to aid in recollection of the channel’s use (such as a club name, etc.). This is easily accomplished using the Set Mode.

1. Recall the memory channel on which you wish to append a label.
2. Press and hold in the [H/L] key for one second to enter the Set mode.
3. Rotate the **DIAL** knob to select the Set Mode Item labeled 29: **NM SET**.
4. Press the [H/L] key momentarily to enable adjustment of this Set Mode Item.
5. Rotate the **DIAL** knob to select the first digit of the desired label.
6. Press the [V/M] key to move to the next character.
7. Repeat steps 5 and 6 to program the remaining letters, numbers, or symbols of the desired label. A total of six characters may be used in the creation of a label.
8. If you make a mistake, press the [BAND] key to back-space the cursor, then re-enter the correct letter, number, or symbol.
9. When you have completed the creation of the label, press the **PTT** key to save the label and exit.

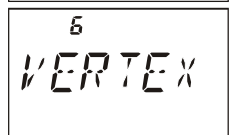
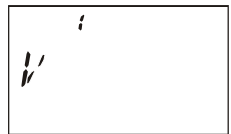
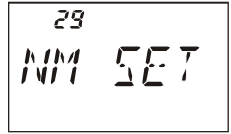

To display the alpha-numeric “Tag” (label):

1. Set the **VX-2R** to the “MR” (Memory Recall) mode, and recall the desired channel.
2. Press and hold in the [H/L] key for one second to enter the Set mode.
3. Rotate the **DIAL** knob to select the Set Mode Item labeled 28: **NAME**.
4. Press the [H/L] key momentarily to enable adjustment of this Item’s setting.
5. Rotate the **DIAL** knob to set this Set Mode Item to “ALPHA” (thus enabling the alpha-numeric display).
6. Press the **PTT** key to save the new setting and activate the alpha-numeric Tag.

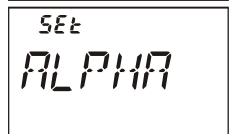

To disable the alpha-numeric Tag (enabling the frequency display), just repeat above procedure, rotating the **DIAL** knob to select “FREQ” in step 5 above.



You may set up some memory channels to have their frequencies displayed, while others may be set to have their Name Tag displayed; the selection within Set Mode Item 28 is not applied to all memory channels at once.

MEMORY MODE

REGULAR MEMORY CHANNEL OPERATION

Memory Offset Tuning

Once you have recalled a particular memory channel, you may easily tune off that channel, as though you were in the “VFO” mode.

1. With the **VX-2R** in the “MR” (Memory Recall) mode, select the desired memory channel.
2. Press the **[F/W]** key, then press the **[V/M]** key to activate the “Memory Tuning” feature. The Memory Channel number will be replaced by “tun.”
3. Rotate the **DIAL** knob, as desired, to tune to a new frequency. The synthesizer steps selected for VFO operation on the current band will be the steps used during Memory Tuning.
4. If you wish to return to the original memory frequency, just press the **[V/M]** key momentarily.
5. If you wish to store a new frequency set during Memory Tuning, just press and hold in the **[F/W]** key for one second, per normal memory storage procedure. The microprocessor will automatically set itself to the next-available clear memory location, and you then press **[F/W]** again to lock in the new frequency.



1) If you want to replace the original memory contents with those of the new frequency, be sure to rotate the DIAL knob to the original memory channel number!

2) Any required CTCSS/DCS changes, or repeater offset modifications, must be done before storing the data into the new (or original) memory channel location.

REGULAR MEMORY CHANNEL OPERATION

Masking Memories

There may be situations where you want to “Mask” memories so they are not visible during memory selection or scanning. For example, several memories used only in a city you visit infrequently may be stored, then “Masked” until you visit that city, at which time you can “Unmask” them for normal use.

1. Press the [**V/M**] key, if needed, to enter the MR mode.
2. Press and hold in the [**F/W**] key for one second, then rotate the **DIAL** knob to select the memory channel to be “Masked” from view.
3. Press the [**⊗**] key. The display will revert to memory channel #1. If you rotate the **DIAL** knob to the location you just “Masked,” you will observe that it is now invisible.
4. To Unmask the hidden memory, repeat the above procedure: press and hold in the [**F/W**] key for one second, rotate the **DIAL** knob to select the masked memory’s number, then press the [**⊗**] key to restore the memory channel’s data.



Watch out! You can manually store data over a “Masked” memory, deleting previous data, if you’re not careful. Use the “next available memory” technique storage technique to avoid over-writing a masked memory.

Moving Memory Data to the VFO

Data stored on memory channels can easily be moved to the VFO, if you like.

1. Select the memory channel containing the frequency data to be moved to VFO.
2. Press and hold in the [**F/W**] key for one second, then press the [**V/M**] key. The data will now have been copied to the VFO, although the original memory contents will remain intact on the previously-stored channel.



If a Split Frequency Memory channel was transferred, the Tx frequency will be ignored (you will be set up for Simplex operation on the Receive frequency).

MEMORY MODE

REGULAR MEMORY CHANNEL OPERATION

Memory Bank Operation

The large number of memories available in the **VX-2R** could be difficult to utilize without some means of organizing them. Fortunately, the **VX-2R** includes provision for dividing the memories into as many as twenty Memory Banks, so you can categorize the memories in a manner convenient to you. You may enter and exit the “Memory Bank” mode by a single press of the [**BAND**] key, as we shall see below.

Assigning Memories to a Memory Bank

1. Recall the memory channel to be assigned to a Memory Bank.
2. Press and hold in the [**F/W**] key for one second, then rotate the **DIAL** knob to select the Memory Bank number you want as the Memory Bank for this channel (“**b 1**” ~ “**b20**,” which is found before memory channel “**1**”).
3. Press the [**F/W**] key momentarily.
4. At this point, the memory channel data is copied into the Memory Bank.



Memory Bank Recall

1. Press the [**V/M**] key, if needed, to enter the MR mode.
2. Press the [**BAND**] key to activate the “Memory Bank” mode. The Memory Bank number will appear on the display.
3. Press the [**F/W**] key, then press the [**BAND**] key.
4. Rotate the **DIAL** knob to select the desired Memory Bank (“**BANK 1**” through “**BANK 20**”).
5. Press the [**BAND**] key; now, as you rotate the **DIAL** knob to select memories, you will observe that you can only select memory channels in the current memory bank.
6. To change to another Memory Bank, press the [**F/W**] key, then press the [**BAND**] key; now rotate the **DIAL** knob to select the new Memory Bank.
7. To exit from Memory Bank operation, just press the [**BAND**] key. “**MEMORY**” will appear on the display, indicating that you are now in the “regular” Memory Recall mode, without utilization of the Memory Banks. The memories stored in the various Banks will remain in those banks, however; you do not need to store them again.



REGULAR MEMORY CHANNEL OPERATION

Memory Only Mode

Once memory channel programming has been completed, you may place the radio in a “Memory Only” mode, whereby VFO operation is impossible. This may be particularly useful during public-service events, where a number of operators may be using the radio for first time, and ultimate simplicity of channel selection is desired.



To place the radio into the Memory Only mode, turn the radio off. Now ***press and hold in*** the [V/M] key while turning the radio on. To return to normal operation, repeat the above power-on procedure.

MEMORY MODE

SPECIAL MEMORY CHANNEL OPERATION

The **VX-2R** provides Special Memory Channels, which made up of:

- 10 “Weather Broadcast” Channels.
- 280 VHF Marine Channels
- 89 popular Short-wave Broadcast Station Memory Channels.



You may assign the Special Memory Channels to a Memory Bank. See page 42 regarding Memory Bank Operation for details.

Weather Broadcast Channels

The VHF Weather Broadcast Station Memory Channel Bank has been pre-programmed at the factory, for quick selection of NOAA weather information stations.

1. Press the [**FW**] key, then press the [**⊗**] key, to recall the Special Memory Menu.
2. Press the [**BAND**] key, repeatedly if necessary to select “**WX CH**” (thus recalling the Weather Broadcast Memory Bank).
3. Rotate the **DIAL** knob to select the desired Weather Broadcast channel.
4. If you wish to scan this bank to search for louder stations, just press the **PTT** switch. When the scanner pauses on a station, press the **PTT** key once to halt the scan, or press it twice to restart the scan.
5. To exit to normal operation, press the [**V/M**] key, or press [**FW**] key followed by the [**⊗**] key.

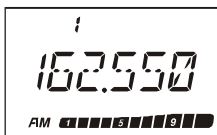
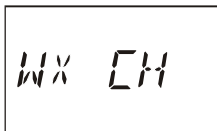

1) In the event of extreme weather disturbances, such as storms and hurricanes, the NOAA (National Oceanic and Atmospheric Administration) sends a weather alert accompanied by a 1050 Hz tone and subsequent weather report on one of the NOAA weather channels. You may disable the Weather Alert tone via Set Mode Item 48: WX ALT, if desired. See page 72.

2) You may append and display an alpha-numeric “Tag” (label) to a Weather Broadcast channel or channels. See page 39 regarding the labeling of a memory for details.

WEATHER BROADCAST CHANNEL FREQUENCY LIST

CH No.	Frequency	CH No.	Frequency	CH No.	Frequency	CH No.	Frequency
1	162.550 MHz	4	162.425 MHz	7	162.525 MHz	10	163.275 MHz
2	165.400 MHz	5	162.450 MHz	8	161.650 MHz	—	—
3	162.475 MHz	6	162.500 MHz	9	161.775 MHz	—	—

SPECIAL MEMORY CHANNEL OPERATION

VHF Marine Channels

Another special Memory Bank contains VHF Marine Channels, pre-programmed at the factory, for quick selection.

1. Press the [**F/W**] key, then press the [**⊗**] key, to recall the Special Memory Menu.
2. Press the [**BAND**] key, repeatedly if necessary, to select “**MA-RINE**” (thus recalling the Marine Channel Memory Bank).
3. Rotate the **DIAL** knob to select any of 280 available VHF Marine Channels.
4. To exit to normal operation, press the [**V/M**] key, or press [**F/W**] key followed by the [**⊗**] key.

VHF MARINE CHANNEL FREQUENCY LIST

CH No.	Frequency (MHz)	CH No.	Frequency (MHz)	CH No.	Frequency (MHz)	CH No.	Frequency (MHz)	CH No.	Frequency (MHz)	CH No.	Frequency (MHz)	CH No.	Frequency (MHz)
0	156.000	41	158.050	82	157.125	123	159.075	164	160.100	205	161.125	246	155.875
1	156.050	42	158.100	83	157.175	124	159.100	165	160.125	206	161.150	247	155.850
2	156.100	43	158.150	84	157.225	125	159.125	166	160.150	207	161.175	248	155.825
3	156.150	44	158.200	85	157.275	126	159.150	167	160.175	208	161.200	249	155.800
4	156.200	45	158.250	86	157.325	127	159.175	168	160.200	209	161.225	250	155.775
5	156.250	46	158.300	87	157.375	128	159.200	169	160.225	210	161.250	251	155.750
6	156.300	47	158.350	88	157.425	129	159.225	170	160.250	211	161.275	252	155.725
7	156.350	48	158.400	89	157.475	130	159.250	171	160.275	212	161.300	253	155.700
8	156.400	49	158.450	90	157.525	131	159.275	172	160.300	213	161.325	254	155.675
9	156.450	50	158.500	91	157.575	132	159.300	173	160.325	214	161.350	255	155.650
10	156.500	51	158.550	92	157.625	133	159.325	174	160.350	215	161.375	256	155.625
11	156.550	52	158.600	93	157.675	134	159.350	175	160.375	216	161.400	257	155.600
12	156.600	53	158.650	94	157.725	135	159.375	176	160.400	217	161.425	258	155.575
13	156.650	54	158.700	95	157.775	136	159.400	177	160.425	218	161.450	259	155.550
14	156.700	55	158.750	96	157.825	137	159.425	178	160.450	219	161.475	260	155.525
15	156.750	56	158.800	97	157.875	138	159.450	179	160.475	220	161.500	261	155.500
16	156.800	57	158.850	98	157.925	139	159.475	180	160.500	221	161.525	262	155.475
17	156.850	58	158.900	99	157.975	140	159.500	181	160.525	222	161.550	263	155.450
18	156.900	59	158.950	100	158.025	141	159.525	182	160.550	223	161.575	264	155.425
19	156.950	60	159.025	101	158.075	142	159.550	183	160.575	224	161.600	265	155.400
20	157.000	61	159.075	102	158.125	143	159.575	184	160.600	225	161.625	266	155.375
21	157.050	62	156.125	103	158.175	144	159.600	185	160.625	226	161.650	267	155.350
22	157.100	63	156.175	104	158.225	145	159.625	186	160.650	227	161.675	268	155.325
23	157.150	64	156.225	105	158.275	146	159.650	187	160.675	228	161.700	269	155.300
24	157.200	65	156.275	106	158.325	147	159.675	188	160.700	229	161.725	270	155.275
25	157.250	66	156.325	107	158.375	148	159.700	189	160.725	230	161.750	271	155.250
26	157.300	67	156.375	108	158.425	149	159.725	190	160.750	231	161.775	272	155.225
27	157.350	68	156.425	109	158.475	150	159.750	191	160.775	232	161.800	273	155.200
28	157.400	69	156.475	110	158.525	151	159.775	192	160.800	233	161.825	274	155.175
29	157.450	70	156.525	111	158.575	152	159.800	193	160.825	234	161.850	275	155.150
30	157.500	71	156.575	112	158.625	153	159.825	194	160.850	235	161.875	276	155.125
31	157.550	72	156.625	113	158.675	154	159.850	195	160.875	236	161.900	277	155.100
32	157.600	73	156.675	114	158.725	155	159.875	196	160.900	237	161.925	278	155.075
33	157.650	74	156.725	115	158.775	156	159.900	197	160.925	238	161.950	279	155.050
34	157.700	75	-	116	158.825	157	159.925	198	160.950	239	161.975	280	155.025
35	157.750	76	-	117	158.875	158	159.950	199	160.975	240	162.000	281	155.000
36	157.800	77	156.875	118	158.925	159	159.975	200	161.000	241	162.025		
37	157.850	78	156.925	119	158.975	160	160.000	201	161.025	242	155.975		
38	157.900	79	156.975	120	159.000	161	160.025	202	161.050	243	155.950		
39	157.950	80	157.025	121	159.025	162	160.050	203	161.075	244	155.925		
40	158.000	81	157.075	122	159.050	163	160.075	204	161.100	245	155.900		

MEMORY MODE

SPECIAL MEMORY CHANNEL OPERATION

Short-Wave Broadcast Station Memory Channels

A large number of Short-Wave Broadcast Station Memory Channels have also been pre-programmed at the factory, for convenient selection of broadcast stations.

1. Press the **[FW]** key, then press the **[⊗]** key, to recall the Special Memory Menu.
2. Press the **[BAND]** key to select the “**RADIO**” (thus recalling the Broadcast Station Channel Memory Bank).
3. Rotate the **DIAL** knob to select any of 89 available Broadcast Stations.
4. Press the **[H/L]** key to toggle the display indication between “Frequency” and “Station Name.”
5. To exit to normal operation, press the **[V/M]** key, or press the **[FW]** key followed by the **[⊗]** key.



BROADCAST STATION FREQUENCY LIST

Ch No.	Freq. (MHz)	MODE	Tag	Station Name	Ch No.	Freq. (MHz)	MODE	Tag	Station Name
1	6.030	AM	VOA	Voice of America	45	7.270	AM	SPAIN	Radio Exterior de Espana
2	6.160	AM	VOA	Voice of America	46	9.520	AM	SPAIN	Radio Exterior de Espana
3	9.760	AM	VOA	Voice of America	47	11.920	AM	SPAIN	Radio Exterior de Espana
4	11.930	AM	VOA	Voice of America	48	15.585	AM	SPAIN	Radio Exterior de Espana
5	5.995	AM	CANADA	Radio Canada International	49	6.090	AM	LUXBRG	Radio Luxembourg
6	7.235	AM	CANADA	Radio Canada International	50	7.485	AM	NORWAY	Radio Norway International
7	9.735	AM	CANADA	Radio Canada International	51	9.590	AM	NORWAY	Radio Norway International
8	11.955	AM	CANADA	Radio Canada International	52	9.985	AM	NORWAY	Radio Norway International
9	6.195	AM	BBC	British Broadcasting Corporation	53	13.800	AM	NORWAY	Radio Norway International
10	9.410	AM	BBC	British Broadcasting Corporation	54	6.065	AM	SWEDEN	Radio Sweden
11	12.095	AM	BBC	British Broadcasting Corporation	55	9.490	AM	SWEDEN	Radio Sweden
12	15.310	AM	BBC	British Broadcasting Corporation	56	13.625	AM	SWEDEN	Radio Sweden
13	6.045	AM	FRANCE	Radio France International	57	17.505	AM	SWEDEN	Radio Sweden
14	9.790	AM	FRANCE	Radio France International	58	6.120	AM	FINLND	Radio Finland
15	11.670	AM	FRANCE	Radio France International	59	9.630	AM	FINLND	Radio Finland
16	15.525	AM	FRANCE	Radio France International	60	11.755	AM	FINLND	Radio Finland
17	3.955	AM	DW	Deutsche Welle	61	9.795	AM	FINLND	Radio Finland
18	6.075	AM	DW	Deutsche Welle	62	5.940	AM	RUSSIA	Voice of Russia
19	9.545	AM	DW	Deutsche Welle	63	5.920	AM	RUSSIA	Voice of Russia
20	9.735	AM	DW	Deutsche Welle	64	7.205	AM	RUSSIA	Voice of Russia
21	6.060	AM	ITALY	Italian Radio International	65	12.030	AM	RUSSIA	Voice of Russia
22	7.175	AM	ITALY	Italian Radio International	66	9.435	AM	ISRAEL	Israel Broadcasting Authority
23	9.515	AM	ITALY	Italian Radio International	67	11.585	AM	ISRAEL	Israel Broadcasting Authority
24	17.710	AM	ITALY	Italian Radio International	68	15.615	AM	ISRAEL	Israel Broadcasting Authority
25	3.985	AM	SWISS	Swiss Radio International	69	17.545	AM	ISRAEL	Israel Broadcasting Authority
26	6.165	AM	SWISS	Swiss Radio International	70	6.045	AM	INDIA	All India Radio (AIR)
27	9.885	AM	SWISS	Swiss Radio International	71	9.595	AM	INDIA	All India Radio (AIR)
28	15.220	AM	SWISS	Swiss Radio International	72	11.620	AM	INDIA	All India Radio (AIR)
29	5.985	AM	BELGUM	Radio Vlaanderen International	73	15.020	AM	INDIA	All India Radio (AIR)
30	9.925	AM	BELGUM	Radio Vlaanderen International	74	7.190	AM	CHINA	China Radio International (CRI)
31	11.780	AM	BELGUM	Radio Vlaanderen International	75	5.250	AM	CHINA	China Radio International (CRI)
32	13.740	AM	BELGUM	Radio Vlaanderen International	76	9.855	AM	CHINA	China Radio International (CRI)
33	5.955	AM	NDELND	Radio Nederland	77	11.685	AM	CHINA	China Radio International (CRI)
34	6.020	AM	NDELND	Radio Nederland	78	5.975	AM	KOREA	Radio Korea
35	9.895	AM	NDELND	Radio Nederland	79	7.275	AM	KOREA	Radio Korea
36	11.655	AM	NDELND	Radio Nederland	80	9.570	AM	KOREA	Radio Korea
37	9.590	AM	DENMRK	Radio Denmark	81	13.670	AM	KOREA	Radio Korea
38	9.985	AM	DENMRK	Radio Denmark	82	6.155	AM	JAPAN	Radio Japan
39	13.800	AM	DENMRK	Radio Denmark	83	7.200	AM	JAPAN	Radio Japan
40	15.735	AM	DENMRK	Radio Denmark	84	9.750	AM	JAPAN	Radio Japan
41	9.780	AM	PORTGL	Radio Portugal	85	11.850	AM	JAPAN	Radio Japan
42	11.960	AM	PORTGL	Radio Portugal	86	5.995	AM	ASTRLA	Radio Australia
43	15.555	AM	PORTGL	Radio Portugal	87	9.580	AM	ASTRLA	Radio Australia
44	21.655	AM	PORTGL	Radio Portugal	88	9.660	AM	ASTRLA	Radio Australia
					89	12080	AM	ASTRLA	Radio Australia

The **VX-2R** allows you to scan just the memory channels, the entire operating band, or a portion of that band. It will halt on signals encountered, so you can talk to the station(s) on that frequency, if you like.

Scanning operation is basically the same in each of the above modes. Before you begin, take a moment to select the way in which you would like the scanner to resume scanning after it halts on a signal.

Setting the Scan-Resume Technique

Five options for the Scan-Resume mode are available:

3 SEC/5 SEC/10 SEC: In this mode, the scanner will halt on a signal it encounters, and will hold there for the selected resume time. If you do not take action to disable the scanner within that time period, the scanner will resume even if the stations are still active.

BUSY: In this mode, the scanner will halt on a signal it encounters. Two seconds after the carrier has dropped because the other station(s) ceased transmission, the scanner will resume. In the case of constant-carrier signals like Weather Station broadcasts, the scanner will likely remain on this frequency indefinitely.

HOLD: In this mode, the scanner will halt on a signal it encounters. It will not restart automatically; you must manually re-initiate scanning if you wish to resume.

To set the Scan-Resume mode:

1. Press and hold in the [**F/W**] key for one second to enter the Set mode.
2. Rotate the **DIAL** knob to select Set Mode Item 31: **RESUME**.
3. Press the [**H/L**] key momentarily to enable adjustment of this Set Mode Item.
4. Rotate the **DIAL** knob to select the desired scan-resume mode.
5. When you have made your selection, press the **PTT** key to save the new setting and exit to normal operation.

R.F. Says: The default condition for this Set Mode Item is “5 SEC.”

Setting the Squelch Level during active Scanning operation

The **VX-2R** allows adjustment of the Squelch level “on the fly” while you are scanning.

1. While the scanner is engaged, press the [**F/W**] key, then press the **MONI** key (the current squelch level will appear below the frequency display).
2. Rotate the **DIAL** to select the desired Squelch level.
3. Press the **PTT** switch momentarily to save the new setting and exit to normal operation. In this case, pressing the **PTT** switch this one time will not causing scanning to stop.

SCANNING

VFO SCANNING

This mode allows you to scan on the VFO mode.

1. Select the VFO mode by pressing the **[V/M]** key, if necessary.
2. Press and hold in the **[BAND]** key for one second, and rotate the DIAL knob *while holding in the [BAND] key* to select the bandwidth for the VFO scanner. Available selections are **±1 MHz**, **±2 MHz**, **±5 MHz**, **BAND**, **ALL**, and **PMS-X**.
BAND: The scanner will sweep frequencies only on the current band.
ALL: The scanner will sweep all frequencies between 0.5 MHz and 999 MHz.
PMS-X: The scanner will sweep frequencies within the currently-selected PMS frequency pair. See page 52 for details.
3. Release the **[BAND]** key to start scanning.
4. If and when the scanner encounters a signal strong enough to open the squelch, the scanner will halt temporarily; the decimal point of the frequency display will blink during this “Pause” condition.
5. The scanner will then resume according to the Scan-Resume mode selected in the previous section.
6. To cancel scanning, press the **PTT** switch or **[V/M]** key.



1) When you start scanning, the VX-2R will be changing frequency in the upward direction. If you want to change direction of the scan while it is underway, rotate the DIAL knob one click in the opposite direction (in this case, one click counter-clockwise). You'll see the scanner turn around and change frequency downward!

2) You may change the scanner's method of operation so that the VFO frequency will jump to the low band edge of the next band when the VFO frequency reaches the high edge of the current band (or vice versa). See page 72 regarding Set Mode Item 47: VFO MD.

VFO SCANNING

How to Skip (Omit) a Frequency during VFO Scan

If the VFO scan stops on a frequency or frequencies that you do not need (such as a spurious radiation from a television), such frequencies can be “skipped” during VFO scanning. This accomplished by storing these frequencies in a special “Frequency Skip Memory” bank reserved for this purpose.

To skip a frequency during VFO scanning:

1. While VFO scanning is stopped on the frequency that you do not need, press and hold the [**F/W**] key for one second, then rotate the **DIAL** knob to select the desired Frequency Skip Memory channel (**901 - 999**, and **000**). The microprocessor will automatically select the next-available “free” Frequency Skip Memory channel (a memory register on which no data has been stored). If you see that any blinking channel number, it means that the channel currently has no data written on it (i.e. the channel is “free”).
2. Press the [**F/W**] key to store the frequency into the Frequency Skip Memory; it now is programmed to be ignored during VFO scanning.

The VX-2R has 100 VFO Frequency Skip Memory Channels.

To re-institute a frequency into the VFO scan loop:

1. Press the [**V/M**] key, if needed, to enter the MR mode.
2. Press and hold in the [**F/W**] key for one second, then rotate the **DIAL** knob to select the memory channel to be re-instituted.
3. Press the [**⊗**] key to delete the channel from the Frequency Skip Memory; this will re-institute the frequency into the VFO scan loop.

MEMORY SCANNING

Memory scanning is similarly easy to initiate:

1. Set the radio to the Memory mode by pressing the [V/M] key, if necessary.
2. Press and hold in the [BAND] key for one second, and rotate the **DIAL** knob while *holding in the [BAND] key* to select the desired Memory Scan mode. Available selections are **ALL CH**, **BAND**, and **PMS-X**.
ALL CH: The scanner sweeps all Memory channels.
BAND: The scanner sweeps only those Memory channels which are memorized on the same operating band as the first channel on which scanning started.
PMS-X: The scanner will sweep frequencies within the currently-selected PMS frequency pair. See page 52 for details.
3. Release the [BAND] key to initiate scanning.
4. As with VFO scanning, the scanner will halt on any signal encountered that is strong enough to open the squelch; it will then resume scanning according to the Scan-Resume mode set previously.
5. To cancel scanning, press the **PTT** switch or [V/M] key.

Temporary Memory Skip

If the scanner repeatedly stops on a channel due to temporary noise or interference, you can temporarily mark it to be skipped (except for Memory Channel “1”). The channel will be skipped until you manually stop the scan (by pressing the **PTT** switch, for example).

To skip a channel temporarily, press the [F/W] key, then press the [BAND] key while the scanner has stopped on the channel to be skipped. The scanner will instantaneously resume, and that channel will not be scanned during this scanning session.

How to Skip (Omit) a Channel during Memory Scan Operation

As mentioned previously, some continuous-carrier stations like a Weather Broadcast station will seriously impede scanner operation if you are using the “Carrier Drop” Scan-Resume mode, as the incoming signal will not pause long enough for the transceiver to resume scanning. Such channels may be “Skipped” during scanning, if you like:

1. Recall the Memory Channel to be skipped during scanning.
2. Press and hold the [H/L] key for one second to enter the Set mode.
3. Rotate the **DIAL** knob to select the Set Mode Item 39: **SKIP**.
4. Press the [H/L] key momentarily to enable adjustment of this Set Mode Item.
5. Rotate the **DIAL** knob so as to select “**SKIP**.” The current Memory Channel will now be ignored during scanning. The “**ONLY**” selection is used for “Preferential Memory Scan,” described in the next column.
6. When you have made your selection, press the **PTT** key to save the setting and exit to normal operation.

MEMORY SCANNING

When you recall the “skipped” memory channel manually, a small “▶” icon will appear at the left of the memory channel number, indicating it is to be ignored during scanning.

To re-institute a channel into the scanning loop, select “**OFF**” in step 5 above (the “Skipped” channel will, of course, still be accessible via manual channel selection methods using the **DIAL** knob in the MR mode, whether or not it is locked out of the scanning loop).

Preferential Memory Scan

The **VX-2R** also allows you to set up a “Preferential Scan List” of channels which you can “flag” within the memory system. These channels are designated by a blinking “▶” icon when you have selected them, one by one, for the Preferential Scan List.

When you initiate memory scanning, beginning on a channel with the blinking “▶” icon appended, only those channels bearing the blinking “▶” icon will be scanned. If you initiate scanning on a channel which does not have the blinking “▶” icon appended, you will scan all channels including those with the blinking “▶” icon appended.

Here is the procedure for setting up and using the Preferential Scan List:

1. Recall the Memory Channel which you wish to add to the Preferential Scan List.
2. Press and hold in the [**H/L**] key for one second to enter the Set mode.
3. Rotate the **DIAL** knob to select Set Mode Item 39: **SKIP**.
4. Press the [**H/L**] key momentarily to enable adjustment of this Set Mode Item.
5. Rotate the **DIAL** knob so as to select “**ONLY**.”
6. When you have made your selection, press the **PTT** key to save the settings and exit to normal operation.

To initiate Preferential Memory Scan:

1. Press the [**V/M**] key momentarily to enter the Memory Recall mode, if you are not using memories already.
2. Rotate the **DIAL** to select any channel which has a blinking “▶” icon appended to the channel number.
3. Press and hold in the [**BAND**] key for one second, and rotate the **DIAL** knob while holding in the [**BAND**] key to select the desired Memory Scan mode.

ALL CH: The scanner sweeps all Preferential Memory channels.

BAND: The scanner sweeps only those Preferential Memory channels which are memorized on the same operating band as the first channel on which scanning started.

PMS-X: This is not Preferential Memory Scan. The scanner will sweep frequencies within the currently-selected PMS frequency pair. See next page for details.

4. Release the [**BAND**] key to initiate Preferential Memory Scanning. Only the channels which have a blinking “▶” icon appended to the channel number will be scanned.

SCANNING

PROGRAMMABLE (BAND LIMIT) MEMORY SCAN (PMS)

This feature allows you to set sub-band limits for either scanning or manual VFO operation. For example, you might wish to set up a limit (in North America) of 144.300 MHz to 148.000 MHz so as to prevent encroachment into the SSB/CW “Weak Signal” portion of the band below 144.300 MHz. Here’s how to do this:

1. Set the radio to the VFO mode by pressing the **[V/M]** key, if necessary.
2. Using the techniques learned earlier, store (per the above concept) 144.300 MHz into Memory Channel #**L1** (the “L” designates the Lower sub-band limit).
3. Likewise, store 148.000 MHz into Memory Channel #**U1** (the “U” designates the Upper sub-band limit).
4. Switch to the Memory mode by pressing the **[V/M]** key once, then rotate the **DIAL** to select Memory Channel # **L1**.
5. Press the **[F/W]** key, then press the **[V/M]** key to start PMS operation; the Memory Channel number will be replaced by “**P 1**.” Tuning and scanning (engaged by pressing and holding in the **[BAND]** key for one second) will now be limited within the just-programmed range.
6. 50 pairs of Band Limit memories, labeled **L1 /U1** through **L50 /U50** are available. You therefore can set upper and lower operation limits on a number of bands, if you like.

“PRIORITY CHANNEL” SCANNING (DUAL WATCH)

The **VX-2R**’s scanning features include a two-channel scanning capability which allows you to operate on a VFO or Memory channel, while periodically checking a user-defined Memory Channel for activity. If a station is received on the Memory Channel which is strong enough to open the Squelch, the scanner will pause on that station in accordance with the Scan-Resume mode set via Set Mode Item 31: **RESUME**. See page 47.

Here is the procedure for activating Priority Channel Dual Watch operation:

1. Press the **[V/M]** key momentarily to enter the Memory Recall mode, if you are not using memories already.
2. Press and hold in the **[F/W]** key for one second, then rotate **DIAL** knob to select the memory channel you wish to be the “Priority” channel.
3. Press the **[BAND]** key. The “**PRI**” icon will appear to the left side of the memory channel number, indicating it is the Priority channel.
4. Now set the **VX-2R** for operation on another memory channel, or on a VFO frequency.
5. Press and hold in the **[V/M]** key for one second. The display will remain on the VFO or memory channel selected; however, the “**DW**” icon will appear on the display, and every five seconds the **VX-2R** will check the Priority Channel for activity. If a station appears on the Priority Channel, the radio will pause on that channel, as described previously.

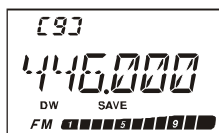

AUTOMATIC LAMP ILLUMINATION ON SCAN STOP

The **VX-2R** will automatically illuminate the LCD Lamp whenever the scanner stops on a signal; this allows you to see the frequency of the incoming signal better at night. Note that this will, of course, increase the battery consumption, so be sure to switch it off during the day (the default condition for this feature is “ON”).

The procedure for disabling the Scan Lamp is:

1. Press and hold in the [**H/L**] key for one second to enter the Set mode.
2. Rotate the **DIAL** knob to select Set Mode Item 37: **SCNLMP**.
3. Press the [**H/L**] key momentarily to enable adjustment of this Set Mode Item.
4. Rotate the **DIAL** knob to set this Set Mode Item to “**OFF**.”
5. When you have made your selection, press the **PTT** key to save the setting and exit to normal operation.

BAND EDGE BEEPER

The **VX-2R** will automatically “beep” when a band edge is encountered during scanning (either in standard VFO scanning or during PMS operation). You may enable this feature (band edge beeper) when the frequency reaches the band edge while selecting the VFO frequency by the **DIAL** knob.

The procedure for enabling the Band-Edge Beeper is:

1. Press and hold in the [**H/L**] key for one second to enter the Set mode.
2. Rotate the **DIAL** knob to select Set Mode Item 19: **EDGBP**.
3. Press the [**H/L**] key momentarily to enable adjustment of this Set Mode Item.
4. Rotate the **DIAL** knob to set this Set Mode Item to “**ON**.”
5. When you have made your selection, press the **PTT** key to save the setting and exit to normal operation.

SMART SEARCH OPERATION

The Smart Search feature allows you to load frequencies automatically according to where activity is encountered by your radio. When Smart Search is engaged, the transceiver will search above and below your current frequency, storing active frequencies as it goes (without stopping on them even momentarily); these frequencies are stored into a special Smart Search memory band, consisting of 31 memories (15 above the current frequency, 15 below the current frequency, plus the current frequency itself).

Two basic operating modes for Smart Search are available:

SINGLE: In this mode, the transceiver will sweep the current band once in each direction starting on the current frequency. All channels where activity is present will be loaded into the Smart Search memories; whether or not all 31 memories are filled, the search will stop after one sweep in each direction.

CONT: In this mode, the transceiver will make one pass in each direction as with One-Shot searching; if all 31 channels are not filled after the first sweep, however, the radio will continue sweeping until they are all filled.

Setting the Smart Search Mode

1. Press and hold in the [H/L] key for one second to enter the Set mode.
2. Rotate the **DIAL** knob to select Set Mode Item 36: **S SCH**.
3. Press the [H/L] key momentarily to enable adjustment of this Set Mode Item.
4. Rotate the **DIAL** knob to select the desired Smart Search mode (see above).
5. When you have made your selection, press the **PTT** switch to save the setting and exit to normal operation.

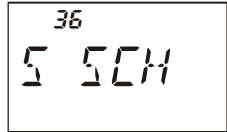

Storing Smart Search Memories

1. Set the radio to the VFO mode. Be sure that you have the Squelch adjusted properly (so that band noise is quieted).
2. Rotate the **DIAL**, while pressing and holding in the **[MD]** key, to select “**S SRCH** (Smart Search mode).”
3. Release the **[MD]** key to enter the Smart Search mode.
4. Press and hold the **[BAND]** key for one second to begin the Smart Search scanning.
5. As active channels are detected, you will observe the number of “loaded” channels increasing in the regular memory channel window.
6. Depending on the mode you set for Smart Search operation (“**SINGLE**” or “**CONT**”), the Smart Search scan will eventually terminate, and the LCD will revert to Smart Search Memory Channel “**C**.”
7. To recall the Smart Search memories, rotate the **DIAL** knob to choose from among the Smart Search memories.
8. To return to normal operation, just press the **[MD]** key.



Smart Search is a great tool when visiting a city for the first time. You don't need to spend hours looking up repeater frequencies from a reference guidebook...just ask your VX-2R where the action is!

CHANNEL COUNTER OPERATION

The Channel Counter allows measuring of the frequency of a nearby transmitter, without knowing that frequency in advance. The frequency can be measured by bringing the **VX-2R** close to the transceiver which is transmitting.

The **VX-2R** performs a high-speed search within a ± 5 MHz range from the frequency displayed on the LCD. When the strongest signal in that range is identified, the **VX-2R** displays the frequency of that (strongest) signal, and writes it into the special “Channel Counter” memory.

Note: This Channel Counter is designed to provide an indication of the operating frequency of the incoming signal, one that is close enough to allow the user, thereafter, to tune precisely to the other station’s frequency. This feature is not, however, designed to provide a precise determination of the other station’s frequency.

1. Set the radio to the VFO mode in the predicted frequency range for the transmitter to be measured.
2. Bring the **VX-2R** into close proximity to the transmitter to be measured.
3. Rotate the **DIAL**, while pressing and holding in the **[MD]** key, to select “**CH CNT** (Channel Counter mode).”
4. Release the **[MD]** key to begin the Channel Counter; the frequency of the nearby station will be displayed. When the channel counter is active, a 50 dB receiver front-end attenuator will be engaged. Therefore, only stations in close proximity may have their frequencies measured using this feature.
5. If it isn’t possible to determine the signal’s frequency, the transceiver will return to the frequency on which you were operating when you started Channel Counter operation.
6. When you are finished, just press the **[MD]** key. The radio will exit from Channel Counter operation.

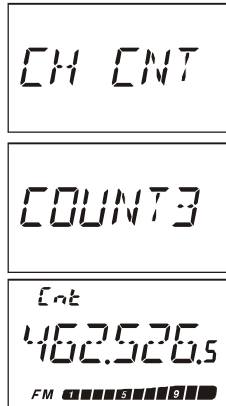

CHANNEL COUNTER OPERATION

Setting the Channel Counter Sweep Width

You may change the bandwidth of the Channel Counter. Available selections are ± 5 , ± 10 , ± 50 , and ± 100 MHz (default: ± 5 MHz).



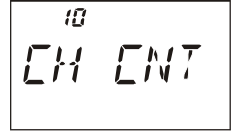

Here is the procedure for setting the Channel Counter Bandwidth:

1. Press and hold in the [H/L] key for one second to enter the Set mode.
2. Rotate the **DIAL** knob to select Set Mode Item 10: **CH CNT**.
3. Press the [H/L] key momentarily to enable adjustment of this Set Mode Item.
4. Rotate the **DIAL** knob to select the desired bandwidth.
5. When you have made your selection, press the **PTT** key to save the new setting and exit to normal operation.



INTERNET CONNECTION FEATURE

The **VX-2R** can be used to access a “node” (repeater or base station) which is tied into the Vertex Standard WIRESTM (Wide-Coverage Internet Repeater Enhancement System) network, operating in the “SRG” (Sister Radio Group) mode. Details may be found at the WIRE-II Web site: <http://www.vxstd.com/en/wiresinfo-en/>. This feature may also be used to access other systems, as described below.

1. Press the [] key to activate the Internet Connection feature. The “” icon will appear in the upper right corner of the display.
2. Rotate the **DIAL** knob, while pressing and holding in the [] key, to select the access number corresponding to the WIRESTM repeater to which you wish to establish an Internet link (ask your repeater owner/operator if you don’t know the access numbers in the network). Now release the [] key to exit from the selection mode.
3. With the Internet Connection feature activated (as in step 1 above), the **VX-2R** will generate a brief (0.1 second) DTMF tone according to your selection in step 2. This DTMF tone is sent at the beginning of every transmission to establish or maintain the link to the remote WIRESTM repeater operating in the SRG mode.
4. To disable the Internet Connection feature, press the [] key again (The “Internet” icon disappear from the display).

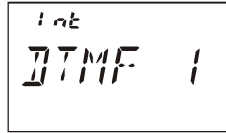

You may access other Internet Link Systems that use a DTMF string for access.

1. Load the DTMF tones which you wish to use for Internet-link access into a DTMF Autodial memory register. For purposes of this example, we will use “#123” as the access code.
 - A. Press and hold in the [**H/L**] key for one second to enter the Set mode.
 - B. Rotate the **DIAL** knob to select Set Mode Item 17: **DTMF**.
 - C. Press the [**H/L**] key to enable adjustment of this Set Mode Item.
 - D. Rotate the **DIAL** knob to set this Item to “**AUTO.**”
 - E. Press the [**H/L**] key momentarily, then rotate the **DIAL** knob one click clockwise to select Set Mode Item 18: **DTMF S**.
 - F. Rotate the **DIAL** knob to select Set Mode Item 18: **DTMF S**.
 - G. Press the [**H/L**] key momentarily, then rotate the **DIAL** knob to select the DTMF Memory register into which you wish to store the access code.
 - H. Press the [**V/M**] key momentarily. The first digit will blink.
 - I. Rotate the **DIAL** knob to select “**F**” (representing DTMF “#”: the first digit of the DTMF string).

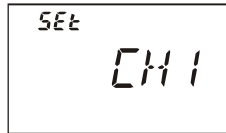
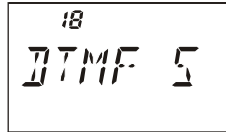
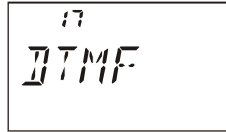

INTERNET CONNECTION FEATURE

- J. Press the [V/M] key momentarily to accept the first digit and move to the second digit of the DTMF string.
 - J. Repeat the previous steps until you have completed the access code (“#123”).
 - K. Press the [H/L] key momentarily to store the DTMF memory.
2. Rotate the **DIAL** knob to select Set Mode Item 23: **INT MD**.
 3. Press the [H/L] key to enable adjustment of this Set Mode Item.
 4. Rotate the **DIAL** knob to set this Set Mode Item to “**LINK**” (thus activating the “Other Internet Link System” mode).
 5. Press the **PTT** key to save the new settings and exit to normal operation.
 6. Press the [☒] key to activate the Internet Connection feature. The “☒” icon will appear in the upper right corner of the display.
 7. If you have stored multiple DTMF strings for access to different link nodes, rotate the **DIAL** knob, while pressing and holding in the [☒] key, to select the DTMF Memory register (CH1 - CH9) corresponding to that node’s DTMF access string.
 8. When the Internet Connection feature is activated per step 6 above, you may now press the [☒] key, while you are transmitting, to send out the selected DTMF string (to establish the link to the desired Internet-link mode).
 9. To return to the WIRES™ mode, repeat steps 2 - 5 above.

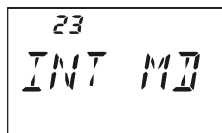
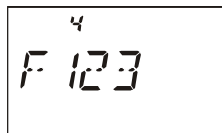
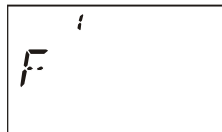

RESET PROCEDURES

In some instances of erratic or unpredictable operation, the cause may be corruption of data in the microprocessor (due to static electricity, etc.). If this happens, resetting of the microprocessor may restore normal operation. Note that all memories will be erased if you do a complete microprocessor reset, as described below.

MICROPROCESSOR RESETTING

To clear all memories and other settings to factory defaults:

1. Turn the radio off.
 2. Press and hold in the **[BAND]**, **[H/L]** and **[V/M]** keys while turning the radio on.
 3. Press the **[F/W]** key momentarily to reset all settings to their factory defaults (press any other key to cancel the Reset procedure).
-

SET MODE RESETTING

To reset the Set Mode Item settings to their factory defaults:

1. Turn the radio off.
2. Press and hold in the **[BAND]** and **[V/M]** keys while turning the radio on.
3. Press the **[F/W]** key momentarily to reset the Set (Menu) mode settings to their factory defaults (press any other key to cancel the Reset procedure).

The **VX-2R** includes a convenient “Clone” feature, which allows the memory and configuration data from one transceiver to be transferred to another **VX-2R**. This can be particularly useful when configuring a number of transceivers for a public service operation. Here is the procedure for Cloning one radio’s data to another:

1. Turn both radios off.
2. Connect the optional **CT-27** Clone Cable between the **MIC/SP** jacks of the two radios.
3. Press and hold in the [**FW**] key while turning the radios on. Do this for both radios (the order of switch-on does not matter). “**CLONE**” will appear on the displays of both radios when the Clone mode is successfully activated in this step.
4. On the *Destination radio*, press the [**V/M**] key (“**WAIT**” will appear on the LCD).
5. Press the [**BAND**] key on the *Source radio*; “**TX**” will appear on the Source radio, and the data from this radio will be transferred to the other radio.
6. If there is a problem during the cloning process, “**ERROR**” will be displayed. Check your cable connections and battery voltage, and try again.
7. If the data transfer is successful, “**CLONE**” will reappear on both displays. Turn both radios off and disconnect the clone cable. You can then turn the radios back on, and begin normal operation.



CLONE



WAIT



TX

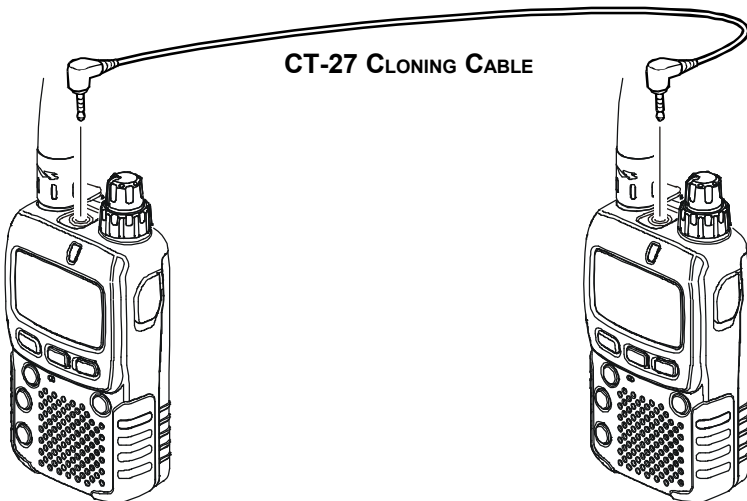

SET (MENU) MODE

The **VX-2R** Set Mode, already described in parts of many previous chapters, is easy to activate and set. It may be used for configuration of a wide variety of transceiver parameters, some of which have not been detailed previously. Use the following procedure to activate the Set Mode:

1. Press and hold in the **[H/L]** key for one second to enter the Set mode.
2. Rotate the **DIAL** knob to select the Set Mode Item to be adjusted.
3. Press the **[H/L]** key momentarily to enable adjustment of the Set Mode Item.
4. Rotate the **DIAL** knob to adjust or select the parameter to be changed on the Set Mode Item selected in above step.
5. After completing your selection and adjustment, press the **PTT** switch momentarily to save the new setting and exit to normal operation.



*Some Set Mode Items (like Set Mode Item 44: TN FRQ) require that the **[H/L]** key be pressed after setting of the parameter, and before exiting to normal operation.*

“MY MENU” Short-cut Key Setup

The MY MENU key function allows you to create a short-cut path for recall of one of Set Mode Items. The **[⊗]** key then serves as the “Short-Cut” key.

1. Press and hold in the **[⊗]** key while turning the radio on. This procedure switches the **[⊗]** key between the “Internet Connection” function and the “MY MENU” key function.
2. Recall the Set Mode Item which you wish to assign to the **[⊗]** key as a Menu short-cut.
3. Press and hold in the **[⊗]** key for one second to assign the Set Mode Item to the **[⊗]** key.

SET (MENU) MODE

Set Mode Item	Function	Available Values (Default: Bold Italic)
1 [APO]	Setting of the Automatic Power-Off feature.	OFF /30MIN/1HOUR/3HOUR/5HOUR/8HOUR
2 [AR BEP]	Selects the Beep option during ARTS operation.	IN RING /ALWAYS/OFF
3 [AR INT]	Selects the Polling Interval during ARTS operation.	25SEC /15SEC
4 [ARS]	Enables/Disables the Automatic Repeater Shift function.	ON/OFF
5 [ATT]	Enables/Disables the receiver Front-end Attenuator.	OFF/ON
6 [BCLO]	Enables/Disables the Busy Channel Lock-Out feature.	ON/OFF
7 [BEEP]	Enables/Disables the Keypad beeper.	ON/OFF
8 [BELL]	Selects the number of CTCSS/DCS Bell ringer repetitions.	OFF /1/3/5/8/CONT
9 [BSYLED]	Enables/Disables the BUSY LED while the Squelch is open.	ON/OFF
10 [CH CNT]	Selects the Channel Counter Search Width.	±5 MHz /±10 MHz/±50 MHz/±100 MHz
11 [CK SFT]	Shifting of the CPU clock frequency.	OFF/ON
12 [CW ID]	Programs and activates the CW Identifier (used during ARTS operation).	---
13 [DC VLT]	Indicates the DC Supply Voltage.	---
14 [DCS CD]	Setting of the DCS code.	104 standard DCS codes (023)
15 [DCS RV]	Enables/Disables "Inverted" DCS code decoding.	DISABL /ENABLE
16 [DIMMER]	Setting of the Display brightness level.	LVL 0 - LVL 12
17 [DTMF]	Selects the DTMF Autodialer Memory Number.	DTMF1 - DTMF 9, or MANUAL
18 [DTMF S]	Programming of the DTMF Autodialer.	---
19 [EDG BP]	Enables/Disables the Band-edge beeper while selecting the frequency by the DIAL knob.	OFF/ON
20 [EMG S]	Select the alarms utilized when the Emergency function is engaged.	BEEP/STROBE/ BP+STR /BEAM/BP+BEM/CW/BP+CW
21 [HLFDEV]	Reducing the Deviation level by 50 %.	OFF/ON
22 [HM/RV]	Selects the function of the [HM/RV] key.	REV /HOME
23 [INT MD]	Selects the "Internet Connection" feature.	WIRES /LINK
24 [LAMP]	Selects the LCD/Keypad Lamp mode.	KEY /CONT/OFF
25 [LOCK]	Selects the Control Locking lockout combination.	KEY /DIAL/K+D/PTT/K+P/D+P/ALL
26 [M/T-CL]	Selects the MONI key (just below the PTT switch) function.	MONI/T-CALL*1
27 [MW MD]	Selects the method of selection of channels for Memory Storage.	NEXT /LOWER
28 [NAME]	Toggles the display indication between "frequency" and the channel's "Alpha/Numeric Tag."	FREQ /ALPHA
29 [NM SET]	Stores Alpha-Numeric "Tags" for the Memory channels.	---
30 [OPNMSG]	Selects the Opening Message that appears when the radio is powered on.	DC /MSG/OFF
31 [RESUME]	Selects the Scan Resume mode.	3 SEC / 5 SEC / 10 SEC /BUSY/HOLD
32 [RF SQL]	Adjusts the RF Squelch threshold level.	S1/S2/S3/S4/S5/S6/S8/S9+/ OFF
33 [RPT]	Sets the Repeater Shift Direction.	SIMP/ RPT + RPT *2
34 [RX MD]	Selects the Receiving mode.	AUTO /N-FM/AM/W-FM
35 [RXSAVE]	Selects the Receive-mode Battery Saver interval ("sleep" ratio).	200MS (1:1)/300MS(1:1.5)/500MS(1:2.5)/1S(1:5)/2S(1:10)/OFF
36 [S SCH]	Selects the Smart Search Sweep mode.	SINGLE /CONT
37 [SCNLMP]	Enables/Disables the Scan lamp while paused.	ON /OFF
38 [SHIFT]	Sets the magnitude of the repeater Shift.	---
39 [SKIP]	Selects the Memory Scan channel-selection mode.	OFF /SKIP/ONLY
40 [SPLIT]	Enables/Disables split CTCSS/DCS coding.	OFF/ON
41 [SQL]	Sets the Squelch threshold level.	Narrow FM: LVL 0 - LVL 15 (LVL 1), Wide FM: LVL 0 - LVL 8 (LVL 2)
42 [SQL TYP]	Selects the Tone Encoder and/or Decoder mode.	OFF /TONE/TSQ/DCS/RV TN
43 [STEP]	Setting of the synthesizer steps.	5/9/10/12.5/15/20/25/50/100 kHz, or AUTO
44 [TN FRQ]	Setting of the CTCSS Tone Frequency.	50 standard CTCSS tones (100.0 Hz)
45 [TOT]	Setting of the TOT time.	OFF /1M/3M/5M/10M (Minutes)
46 [TXSAVE]	Enables/Disables the Transmitter Battery Saver.	OFF /ON
47 [VFO MD]	Selects or disables the VFO band edge limiting for the current band.	BAND /ALL
48 [WX ALT]	Enables/Disables the NOAA Weather Alert Feature.	OFF/ON

*1: Depends on transceiver version.

*2: Depends on operating band and transceiver version.

SET (MENU) MODE

SQL SETTING

Adjusts the RF Squelch threshold level.
Sets the Squelch threshold level.

SET MODE ITEM AVAILABLE VALUES (DEFAULT)

32 [RF SQL] S1/S2/S3/S4/S5/S6/S8/S9+/OFF
41 [SQL] Narrow FM: LVL 0 - LVL 15 (**LVL 1**),
Wide FM: LVL 0 - LVL 8 (**LVL 2**)

REPEATER SETTING

Enables/Disables the Automatic Repeater Shift function.
Sets the Repeater Shift Direction.
Sets the magnitude of the repeater Shift.

SET MODE ITEM AVAILABLE VALUES (DEFAULT)

4 [ARS] ON/OFF
33 [RPT] SIMP-/RPT+/RPT*1
38 [SHIFT] ---

CTCSS/DCS/DTMF SETTING

Selects the number of CTCSS/DCS Bell ringer repetitions.
Setting of the DCS code.
Enables/Disables "Inverted" DCS code decoding.
Selects the DTMF Autodialer Memory Number.
Programming of the DTMF Autodialer.
Enables/Disables split CTCSS/DCS coding.
Selects the Tone Encoder and/or Decoder mode.
Setting of the CTCSS Tone Frequency.

SET MODE ITEM AVAILABLE VALUES (DEFAULT)

8 [BELL] OFF/1/3/5/8/CONT
14 [DCS CD] 104 standard DCS codes (**023**)
15 [DCS RV] **DISAB**/ENABLE
17 [DTMF] DTMF1 - DTMF 9, or **MANUAL**
18 [DTMF S] ---
40 [SPLIT] OFF/OFF
42 [SQL TYP] OFFTONE/TSQ/DCS/RV TN
44 [TN FRQ] 50 standard CTCSS tones (**100.0 Hz**)

ARTS SETTING

Selects the Beep option during ARTS operation.
Selects the Polling Interval during ARTS operation.
Programs and activates the CW Identifier
(used during ARTS operation).

SET MODE ITEM AVAILABLE VALUES (DEFAULT)

2 [AR BEP] **IN RNG**/ALWAYS/OFF
3 [AR INT] **25SEC**/15SEC
12 [CW ID] ---

MEMORY SETTING

Selects the method of selection of channels for Memory Storage.
Toggles the display indication between
"frequency" and the channel's "Alpha/Numeric Tag."
Stores Alpha-Numeric "Tags" for the Memory channels.

SET MODE ITEM AVAILABLE VALUES (DEFAULT)

27 [MW MD] **NEXT**/LOWER
28 [NAME] **FREQ**/ALPHA

SCAN SETTING

Selects the Memory Scan channel-selection mode.
Selects the Channel Counter Search Width.
Selects the Scan Resume mode.
Selects the Smart Search Sweep mode.
Enables/Disables the Scan lamp while paused.

SET MODE ITEM AVAILABLE VALUES (DEFAULT)

29 [NM SET] ---
239 [SKIP] OFF/SKIP/ONLY
10 [CH CNT] **±5 MHz**/±10 MHz/±50 MHz/±100 MHz
31 [RESUME] 3 SEC/**5 SEC**/10 SEC/BUSY/HOLD
36 [S SCH] **SINGLE**/CONT
37 [SCANLMP] ON/OFF

POWER SAVE SETTING

Setting of the Automatic Power-Off feature.

Enables/Disables the BUSY LED while the Squelch is open.
Selects the Receive-mode Battery Saver interval ("sleep" ratio).

SET MODE ITEM AVAILABLE VALUES (DEFAULT)

1 [APO] OFF/30MIN/1HOUR/3HOUR/5HOUR/
8HOUR
9 [BSYLED] ON/OFF
35 [RXSAVE] **200MS**(1:1)/300MS(1:1.5)/
500MS(1:2.5)/1S(1:5)/2S(1:10)/OFF
45 [TOT] OFF/1M/3M/5M/10M (Minutes)
46 [TXSAVE] OFF/OFF

Setting of the TOT time.

Enables/Disables the Transmitter Battery Saver.

SET MODE ITEM AVAILABLE VALUES (DEFAULT)

16 [DIMMER] LVL 0 - **LVL 12**
24 [LAMP] **KEY**/CONT/OFF

DISPLAY SETTING

Setting of the Display brightness level.
Selects the LCD/Keypad Lamp mode.

SWITCH/KNOB SETTING

Enables/Disables the Keypad beeper.
Selects the function of the [HM/RV] key.
Selects the **MONI** key (just below the PTT switch) function.
Selects the Control Locking lockout combination.

SET MODE ITEM AVAILABLE VALUES (DEFAULT)

7 [BEEP] ON/OFF
22 [HM/RV] **REV**/HOME
26 [M/T-CL] **MONI**/T-CALL*2
25 [LOCK] **KEY**/DIAL/K+D/P/TT/K+P/D+P/ALL

MISCELLANEOUS SETTING

Enables/Disables the receiver Front-end Attenuator.
Enables/Disables the Busy Channel Lock-Out feature.
Shifting of the CPU clock frequency.
Indicates the DC Supply Voltage.
Enables/Disables the Band-edge beeper
while selecting the frequency by the **DIAL** knob.
Select the alarms utilized when the Emergency function is engaged.

SET MODE ITEM AVAILABLE VALUES (DEFAULT)

5 [ATT] OFF/OFF
6 [BCLO] OFF/OFF
11 [CK SFT] OFF/OFF
13 [DC VLT] ---
19 [EDG BP] OFF/OFF
20 [EMG S] BEEP/STROBE/**BP+STR**/BEAM/
BP+BEM/CW/BP+CW
ON/OFF

Reducing the Deviation level by 50 %.

Selects the "Internet Connection" feature.
Selects the Opening Message that appears
when the radio is powered on.

21 [HLFDEV] **WIRE**S/LINK
23 [INT MD] **DC**/MSG/OFF
30 [OPNMSG]

Selects the Receiving mode.
Setting of the synthesizer steps.

34 [RX MD] **AUTO**/N-FM/AM/W-FM
43 [STEP] 5/9/10/12.5/15/20/25/50/100 kHz, or
AUTO

Selects or disables the VFO band edge limiting for the current band.
Enables/Disables the NOAA Weather Alert Feature.

47 [VFO MD] **BAND**/ALL
48 [WX ALT] OFF/OFF

*1: Depends on operating band and transceiver version.

*2: Depends on transceiver version.

SET MODE SUMMARY

Set Mode Item 1 [APO]

Function: Setting of the Automatic Power-Off feature.

Available Values: OFF/30MIN/1HOUR/3HOUR/5HOUR/8HOUR

Default: OFF

Set Mode Item 2 [AR BEP]

Function: Selects the Beep option during ARTS operation.

Available Values: IN RNG/ALWAYS/OFF

Default: IN RNG

IN RNG: Beeps sound only when the radio first detects that you are within range.

ALWAYS: Beeps sound every time a polling transmission is received from the other station (every 15 or 25 seconds when in range).

OFF: No alert beeps sound.

Set Mode Item 3 [AR INT]

Function: Selects the Polling Interval during ARTS operation.

Available Values: 25SEC/15SEC

Default: 25SEC

Set Mode Item 4 [ARS]

Function: Enables/Disables the Automatic Repeater Shift function.

Available Values: ON/OFF

Default: ON

Set Mode Item 5 [ATT]

Function: Enables/Disables the receiver Front-end Attenuator.

Available Values: OFF/ON

Default: OFF

Set Mode Item 6 [BCLO]

Function: Enables/Disables the Busy Channel Lock-Out feature.

Available Values: ON/OFF

Default: OFF

Set Mode Item 7 [BEEP]

Function: Enables/Disables the Keypad beeper.

Available Values: ON/OFF

Default: ON

Set Mode Item 8 [BELL]

Function: Selects the number of CTCSS/DCS Bell ringer repetitions.

Available Values: OFF/1/3/5/8/CONT (Continuous ringing)

Default: OFF

SET (MENU) MODE

SET MODE SUMMARY

Set Mode Item 9 [BSYLED]

Function: Enables/Disables the BUSY LED while the Squelch is open.

Available Values: ON/OFF

Default: ON

Set Mode Item 10 [CH CNT]

Function: Selects the Channel Counter Search Width.

Available Values: ± 5 MHz/ ± 10 MHz/ ± 50 MHz/ ± 100 MHz

Default: ± 5 MHz

Set Mode Item 11 [CK SFT]

Function: Shifting of the CPU clock frequency.

Available Values: OFF/ON

Default: OFF

This function is only used to move a spurious response “birdie,” should it fall on a desired frequency.

Set Mode Item 12 [CW ID]

Function: Programs and activates the CW Identifier (used during ARTS operation).

See page ?? for details.

Set Mode Item 13 [DC VLT]

Function: Indicates the DC Supply Voltage.

Set Mode Item 14 [DCS RV]

Function: Setting of the DCS code.

Available Values: 104 standard DCS codes

Default: 023

DCS CODE									
023	025	026	031	032	036	043	047	051	053
054	065	071	072	073	074	114	115	116	122
125	131	132	134	143	145	152	155	156	162
165	172	174	205	212	223	225	226	243	244
245	246	251	252	255	261	263	265	266	271
274	306	311	315	325	331	332	343	346	351
356	364	365	371	411	412	413	423	431	432
445	446	452	454	455	462	464	465	466	503
506	516	523	526	532	546	565	606	612	624
627	631	632	654	662	664	703	712	723	731
732	734	743	754	-	-	-	-	-	-

Set Mode Item 15 [DCS CP]

Function: Enables/Disables “Inverted” DCS code decoding.

Available Values: DISABL/ENABLE

Default: DISABL

Set Mode Item 16 [DIMMER]

Function: Setting of the Display brightness level.

Available Values: LVL 0 - LVL 12

Default: LVL 12

SET MODE SUMMARY

Set Mode Item 17 [DTMF]

Function: Selects the DTMF Autodialer Memory Number.

Available Values: DTMF1 - DTMF 9, or MANUAL

Default: MANUAL

Set Mode Item 18 [DTMF S]

Function: Programming of the DTMF Autodialer.

See page ?? for details.

Set Mode Item 19 [EDG BP]

Function: Enables/Disables the Band-edge beeper while selecting the frequency by the **DIAL** knob.

Available Values: OFF/ON

Default: OFF

Set Mode Item 20 [EMG S]

Function: Select the alarms utilized when the Emergency function is engaged.

Available Values: BEEP/STROBE/BP+STR/BEAM/BP+BEM/CW/BP+CW

Default: BP+STR

BEEP (BP): Loud “Alarm” sounds.

STROBE (STB): Flashes the **BUSY/TX** indicator in bright white color.

BP+STB: Loud “Alarm” sounds along with flashing of the **BUSY/TX** indicator in white.

BEAM: The **BUSY/TX** indicator glows continuously in white.

BP+BEM: Loud “Alarm” sounds and the **BUSY/TX** indicator glows continuously in white.

CW: The **BUSY/TX** indicator flashes according to the programmed Emergency message (Morse Code)* at a rate of five words per minute.

BP+CW: Sounds tones via the speaker, and flashes the **BUSY/TX** indicator, according to the programmed Emergency message (Morse Code)* at a rate of five words per minute. The internationally-recognized Morse Code “S.O.S” message (•••--•••) is programmed at the factory for the Emergency message.

※Here’s how to program the Emergency Message:

1. Set this Set Mode Item to “CW” or “BP+CW.”
2. Press the [**V/M**] key to enable programming of the emergency message. You will notice the first character entry’s place blinking.
3. Rotate the **DIAL** knob to select the first letter/number of the message, then press the [**V/M**] key momentarily to save the first letter/number and move on to the next character.

SET (MENU) MODE

SET MODE SUMMARY

4. Repeat the previous step as necessary to complete the message (up to 16 characters).
5. If you make a mistake, press the [**BAND**] key to back-space the cursor; now re-enter the correct letter/number.
6. Press the [**HM/RV**] key to delete all data after the cursor that may have been previously stored erroneously.
7. When you have entered the message, press the [**H/L**] key momentarily to confirm the message, then press the PTT key to save the settings and exit to normal operation.

Set Mode Item 21 [HLFDEV]

Function: Reducing the Deviation level by 50 %.

Available Values: OFF/ON

Default: OFF

Set Mode Item 22 [HM/RV]

Function: Selects the function of the [**HM/RV**] key.

Available Values: REV/HOME

Default: REV

REV: Pressing the [**HM/RV**] key reverses the transmit and receive frequencies during repeater operation.

HOME: Pressing the [**HM/RV**] key instantly recalls a favorite “Home” channel.

Set Mode Item 23 [INT MD]

Function: Selects the “Internet Connection” feature.

Available Values: WIRES/LINK

Default: WIRES (sends a single DTMF digit at the beginning of each transmission)

Set Mode Item 24 [LAMP]

Function: Selects the LCD/Keypad Lamp mode.

Available Values: KEY/CONT/OFF

Default: KEY

KEY: Illuminates the LCD/Keypad for 5 seconds when any key is pressed.

CONT: Illuminates the LCD/Keypad continuously.

OFF: Disables the LCD/Keypad illumination

Set Mode Item 25 [LOCK]

Function: Selects the Control Locking lockout combination.

Available Values: KEY/DIAL/K+D/PTT/K+P/D+P/ALL

Default: KEY

Note: “K” = “Key;” “D” = “Dial;” and “P” = “PTT.”

SET MODE SUMMARY

Set Mode Item 26 [M/T-CL]

Function: Selects the **MONI** key (just below the **PTT** switch) function.

Available Values: MONI/T-CALL

Default: Depends on the transceiver version.

MONI: Pressing the **MONI** key causes the Noise/Tone Squelch to be over-ridden, allowing you to listen for weak (or non-encoded) signals.

T-CALL: Pressing the **MONI** key activates a 1750-Hz burst tone, used for repeater access in many countries (especially in Europe).

Set Mode Item 27 [MW MD]

Function: Selects the method of selection of channels for Memory Storage.

Available Values: NEXT/ LOWER

Default: NEXT

NEXT: Stores the data into the memory channel which is next-highest from the last-stored memory channel.

LOWER: Stores the data into the next-available “free” channel.

Set Mode Item 28 [NAME]

Function: Toggles the display indication between “frequency” and the channel’s “Alpha/Numeric Tag.”

Available Values: FREQ/ALPHA

Default: FREQ

Set Mode Item 29 [NM SET]

Function: Stores Alpha-Numeric “Tags” for the Memory channels.

See page 39 for details.

Set Mode Item 30 [OPNMSG]

Function: Selects the Opening Message that appears when the radio is powered on.

Available Values: DC/MSG/OFF

Default: DC

DC: DC supply voltage

MSG: Set by user. See below.

OFF: No Opening Message

Here’s how to program the Opening Message:

1. Set this Set Mode Item to “MSG.”
2. Press the [**V/M**] key momentarily to enable programming of the opening message. You will notice the first character entry’s location blinking.
3. Rotate the **DIAL** knob to select the first letter/number of the message, then press the [**V/M**] key momentarily to save the first letter/number and move on to the next character.

SET (MENU) MODE

SET MODE SUMMARY

4. Repeat the previous step as necessary to complete the message (up to six characters).
5. If you make a mistake, press the [**BAND**] key to back-space the cursor; now re-enter the correct letter/number.
6. Press the [**HM/RV**] key to delete all data after the cursor that may have been previously stored erroneously.
7. When you have entered the desired opening message, press the [**H/L**] key momentarily to confirm the message, then press the **PTT** key to save the settings and exit to normal operation.

Set Mode Item 31 [RESUME]

Function: Selects the Scan Resume mode.

Available Values: 3 SEC/5 SEC/10 SEC/BUSY/HOLD

Default: 5 SEC

3 SEC/5 SEC/10 SEC: The scanner will hold for the selected resume time, then resume whether or not the other station is still transmitting.

BUSY: The scanner will hold until the signal disappears, then will resume when the carrier drops.

HOLD: The scanner will stop when a signal is received, and will not re-start.

Set Mode Item 32 [RF SQL]

Function: Adjusts the RF Squelch threshold level.

Available Values: S1/S2/S3/S4/S5/S6/S8/S9+/OFF

Default: OFF

Set Mode Item 33 [RPT]

Function: Sets the Repeater Shift Direction.

Available Values: SIMP/-RPT/+RPT

Default: Depends on the transceiver version, as well as the setting of Set Mode Item 5 [ARS].

Set Mode Item 34 [RX MD]

Function: Selects the Receiving mode.

Available Values: AUTO/N-FM/AM/W-FM

Default: AUTO (Mode automatically changes according to operating frequency.)

Set Mode Item 35 [RXSAVE]

Function: Selects the Receive-mode Battery Saver interval (“sleep” ratio)

Available Values: 200MS(1:1)/300MS(1:1.5)/500MS(1:2.5)/1S(1:5)/2S(1:10)/OFF

Default: 200MS

SET MODE SUMMARY

Set Mode Item 36 [S SCH]

Function: Selects the Smart Search Sweep mode.

Available Values: SINGLE/CONT

Default: SINGLE

SINGLE: The transceiver sweeps the current band once in each direction starting on the current frequency. All channels where activity is present (up to 15 in each direction) are loaded into the Smart Search memories. Whether or not all 31 memories are filled, the search stops after one sweep in each direction.

CONT: The transceiver makes a sweep in each direction as with the “SINGLE” mode, but if all 31 channels are not filled after the first sweep, the radio continues sweeping until they are all filled.

Set Mode Item 37 [SCNLMP]

Function: Enables/Disables the Scan lamp while paused.

Available Values: ON/OFF

Default: ON

Set Mode Item 38 [SHIFT]

Function: Sets the magnitude of the repeater Shift.

Available Values: 0.00 - 99.95 MHz (50 kHz increments)

Default: Depends on the operating band and transceiver version.

Set Mode Item 39 [SKIP]

Function: Selects the Memory Scan channel-selection mode.

Available Values: OFF/SKIP/ONLY

Default: OFF

SKIP: The scanner will “skip” the flagged channels during scanning.

ONLY: The scanner will only scan channels that are flagged (Preferential Scan List).

OFF: All memory channels will be scanned (the “flag” will be ignored).

Set Mode Item 40 [SPLIT]

Function: Enables/Disables split CTCSS/DCS coding.

Available Values: OFF/ON

Default: OFF

When this Set Mode Item is set to “ON,” you can see the following additional parameters after the “RV TN” parameter while selecting the Set Mode Item 42: **SQL TYP.**

D CODE: DCS Encode only.

T DCS: Encodes a CTCSS tone and Decodes a DCS code.

D TONE: Encodes a DCS code and Decodes a CTCSS tone.

Select the desired operating mode from the selections shown above.

SET (MENU) MODE

SET MODE SUMMARY

Set Mode Item 41 [SQL]

Function: Sets the Squelch threshold level.

Available Values: LVL 0 - LVL 15 (Narrow FM), LVL 0 - LVL 8 (Wide FM)

Default: LVL 1 (Narrow FM), LVL 2 (Wide FM)

Set Mode Item 42 [SQL TYP]

Function: Selects the Tone Encoder and/or Decoder mode.

Available Values: OFF/TONE/TSQ/DCS/RV TN

Default: OFF

TONE: CTCSS Encoder

TSQ: CTCSS Encoder/Decoder

DCS: Digital Coded Encoder/Decoder

RV TN: Reverse CTCSS Decoder

Note: See also Set Mode Item 40: **SPLIT** regarding additional selections available during “Split Tone” operation.

Set Mode Item 43 [STEP]

Function: Setting of the synthesizer steps.

Available Values: 5/9/10/12.5/15/20/25/50/100 kHz, or AUTO

Default: AUTO (Step automatically changes according to operating frequency.)

Set Mode Item 44 [TN FRQ]

Function: Setting of the CTCSS Tone Frequency.

Available Values: 50 standard CTCSS tones

Default: 100.0 Hz

CTCSS TONE FREQUENCY (Hz)					
67.0	69.3	71.9	74.4	77.0	79.7
82.5	85.4	88.5	91.5	94.8	97.4
100.0	103.5	107.2	110.9	114.8	118.8
123.0	127.3	131.8	136.5	141.3	146.2
151.4	156.7	159.8	162.2	165.5	167.9
171.3	173.8	177.3	179.9	183.5	186.2
189.9	192.8	196.6	199.5	203.5	206.5
210.7	218.1	225.7	229.1	233.6	241.8
250.3	254.1	-	-	-	-

Set Mode Item 45 [TOT]

Function: Setting of the TOT time

Available Values: OFF/1M/3M/5M/10M (Minutes)

Default: OFF

The time-out timer shuts off the transmitter after continuous transmission of the programmed time.

Set Mode Item 46 [TXSAVE]

Function: Enables/Disables the Transmitter Battery Saver.

Available Values: OFF/ON

Default: OFF

SET MODE SUMMARY

Set Mode Item 47 [VFO MD]

Function: Selects or disables the VFO band edge limiting for the current band.

Available Values: BAND/ALL

Default: BAND

BAND: When the VFO frequency reaches the high band edge of the current band, the VFO frequency will jump to the low band edge of the current band (or vice versa).

ALL: When the VFO frequency reaches the high edge of the current band, the VFO frequency will jump to the low band edge of the next band (or vice versa).

Set Mode Item 48 [WX ALT]

Function: Enables/Disables the NOAA Weather Alert Feature.

Available Values: OFF/ON

Default: OFF

SPECIFICATIONS

General

Frequency Ranges: (USA Version)	RX 0.5-1.8 MHz (BC Band) 1.8-30 MHz (SW Band) 30-76 (59) MHz (50 MHz HAM) 76 (59)-108 MHz (FM) 108-137 MHz (Air Band) 137-174 MHz (144 MHz HAM) 174-222 MHz (VHF TV) 222-420 MHz (ACT1) 420-470 MHz (430 MHz HAM) 470-800 (729) MHz (UHF TV) (757-774) MHz (UHF TV) 800-999 MHz (ACT2; USA Cellular Blocked)
	TX 144-146 (148) MHz 430-440 (450) MHz
Channel Steps:	5/9/10/12.5/15/20/25/50/100 kHz
Frequency Stability:	±5 ppm (14 °F to +140 °C [-10 °C to +60 °C])
Repeater Shift:	±600 kHz (144 MHz) ±1.6/5.0/7.6 MHz (430 MHz)
Emission Type:	F2 , F3
Antenna Impedance:	50 Ω
Supply Voltage:	Nominal: 3.7 V DC, Negative Ground Operating: 3.2 - 7.0 V, Negative Ground (EXT DC Jack) 5.5 - 7.0 V, Negative Ground (EXT DC Jack with Charging)
Current Consumption:	150 mA (Receive) 58 mA (Standby, Saver Off) 20 mA (Standby, Saver On) 200 μA (Auto Power Off) 1.3 A (1.5 W Tx , 144 MHz) 3.7 V DC 1.8 A (3 W Tx , 144 MHz) 6.0 V DC 1.2 A (1 W Tx , 430 MHz) 3.7 V DC 1.5 A (2 W Tx , 430 MHz) 6.0 V DC
Operating Temperature:	-4 °F to +140 °F (-20 °C to +60 °C)
Case Size (W x H x D):	1.9 x 3.2 x 0.9 inch (47 x 81 x 23 mm) (W/O knob & antenna)
Weight:	4.6 oz (132 g) With FNB-82LI & antenna

Transmitter

RF Power Output:	1.5 W (@ 3.7 V FNB-82LI 144 MHz) 3 W (@ 6.0 V EXT DC IN 144 MHz) 1 W (@ 3.7 V FNB-82LI 430 MHz) 2 W (@ 6.0 V EXT DC IN 430 MHz)
Modulation Type:	Variable Reactance F2 , F3
Maximum Deviation:	±5 kHz (F2, F3)
Spurious Emission:	At least 60 dB below (HIGH) At least 50 dB below (LOW)
Microphone Impedance:	2 kΩ

Receiver

Circuit Type:	AM, NFM: Double-Conversion Superheterodyne WFM: Triple-Conversion Superheterodyne												
Intermediate Frequencies:	<table><thead><tr><th></th><th>1st</th><th>2nd</th><th>3rd</th></tr></thead><tbody><tr><td>AM, NFM</td><td>47.25MHz</td><td>450 kHz</td><td>–</td></tr><tr><td>WFM</td><td>45.8 MHz</td><td>10.7 MHz</td><td>1 MHz</td></tr></tbody></table>		1st	2nd	3rd	AM, NFM	47.25MHz	450 kHz	–	WFM	45.8 MHz	10.7 MHz	1 MHz
	1st	2nd	3rd										
AM, NFM	47.25MHz	450 kHz	–										
WFM	45.8 MHz	10.7 MHz	1 MHz										
Sensitivity:	3 μV for 10 dB SN (0.5-30 MHz, AM) 0.35 μV TYP for 12 dB SINAD (30-54 MHz, NFM) 1 μV TYP for 12 dB SINAD (54-76 MHz, NFM) 1.5 μV TYP for 12 dB SINAD (76-108 MHz, WFM) 1.5 μV TYP for 10 dB SN (108-137 MHz, AM) 0.2 μV for 12 dB SINAD (137-140 MHz, NFM) 0.16 μV for 12 dB SINAD (140-150 MHz, NFM) 0.2 μV for 12 dB SINAD (150-174 MHz, NFM) 1 μV TYP for 12 dB SINAD (174-222 MHz, WFM) 0.5 μV for 12 dB SINAD (300-350 MHz, NFM) 0.2 μV for 12 dB SINAD (350-400 MHz, NFM) 0.18 μV for 12 dB SINAD (400-470 MHz, NFM) 1.5 μV for 12 dB SINAD (470-540 MHz, WFM) 3 μV TYP for 12 dB SINAD (540-800 MHz, WFM) 1.5 μV TYP for 12 dB SINAD (800 -999 MHz, NFM) USA Version Cellular Blocked												
Selectivity:	NFM, AM: 12 kHz/35 kHz (–6 dB/–60 dB) WFM: 200 kHz/300 kHz (–6 dB/–20 dB)												
AF Output:	50 mW @ 8 Ω for 10 % THD (@ 3.7 V) 100 mW @ 8 Ω for 10 % THD (@ 6.0 V)												

Specifications are subject to change without notice, and are guaranteed within the 144 and 430 MHz amateur bands only. Frequency ranges will vary according to transceiver version; check with your dealer.

"AUTO" MODE PRESET OPERATING PARAMETERS

USA Version

FREQUENCY RANGE (MHz)	MODE	STEP
0.500 - 1.800	AM	10 kHz
1.800 - 30.000	AM	5 kHz
30.000 - 50.500	AM	5 kHz
50.500 - 59.000	FM	5 kHz
59.000 - 88.000	WFM	50 kHz
88.000 - 108.000	WFM	100 kHz
108.000 - 137.000	AM	25 kHz
137.000 - 144.000	FM	12.5 kHz
144.000 - 148.000	FM	5 kHz
148.000 - 156.000	FM	12.5 kHz
156.000 - 157.450	FM	25 kHz
157.450 - 160.600	FM	12.5 kHz
160.600 - 160.975	FM	25 kHz
160.975 - 161.500	FM	12.5 kHz
161.500 - 162.900	FM	25 kHz
162.900 - 174.000	FM	12.5 kHz
174.000 - 222.000	WFM	50 kHz
222.000 - 225.000	FM	5 kHz
225.000 - 300.000	FM	12.5 kHz
300.000 - 336.000	AM	100 kHz
336.000 - 420.000	FM	12.5 kHz
420.000 - 450.000	FM	25 kHz
450.000 - 470.000	FM	12.5 kHz
470.000 - 800.000	WFM	50 kHz
803.000 - 999.000	FM	12.5 kHz

Cellular Blocked

EXP Version

FREQUENCY RANGE (MHz)	MODE	STEP
0.500 - 1.800	AM	9 kHz
1.800 - 30.000	AM	5 kHz
30.000 - 76.000	FM	5 kHz
76.000 - 88.000	FM	5 kHz
88.000 - 108.000	WFM	100 kHz
108.000 - 137.000	AM	25 kHz
137.000 - 160.600	FM	12.5 kHz
160.600 - 162.025	FM	25 kHz
162.025 - 174.000	FM	12.5 kHz
174.000 - 222.000	WFM	50 kHz
222.000 - 300.000	FM	12.5 kHz
300.000 - 320.000	AM	25 kHz
320.000 - 420.000	FM	12.5 kHz
420.000 - 430.000	FM	12.5 kHz
430.000 - 440.000	FM	25 kHz
440.000 - 470.000	FM	12.5 kHz
470.000 - 800.000	WFM	50 kHz
800.000 - 999.000	FM	12.5 kHz

1. Changes or modifications to this device not expressly approved by VERTEX STANDARD could void the user's authorization to operate this device.
2. This device complies with part 15 of the FCC Rules. Operation is subject to the following two conditions: (1) This device may not cause harmful interference, and (2) this device must accept any interference including received, interference that may cause undesired operation.
3. The scanning receiver in this equipment is incapable of tuning, or readily being altered, by the User to operate within the frequency bands allocated to the Domestic public Cellular Telecommunications Service in Part 22.

DECLARATION BY MANUFACTURER

The Scanner receiver is not a digital scanner and is incapable of being converted or modified to a digital scanner receiver by any user.

WARNING: MODIFICATION OF THIS DEVICE TO RECEIVE CELLULAR RADIOTELEPHONE SERVICE SIGNALS IS PROHIBITED UNDER FCC RULES AND FEDERAL LAW.



Copyright 2003
VERTEX STANDARD CO., LTD.
All rights reserved.

Printed in Japan

No portion of this manual
may be reproduced
without the permission of
VERTEX STANDARD CO., LTD.



E H 0 1 5 M 1 0 0

0304G-0E