

**GR1**  
**ZONE MIXER**



**SERVICE  
MANUAL**

PUBLICATION AP2059

## INTRODUCTION

---

The information presented in this manual is intended for competent technical personnel to carry out service and product support for the **GRI**. We assume that the reader is familiar with the related electronic theory and audio terminology, and is able to carry out basic servicing, fault-finding and repair of audio equipment of this type. Service personnel should also be familiar with audio systems, mains earthing and power requirements, as well as handling precautions.

For further information on the operation and application of the **GRI** please refer to the **USER GUIDE** publication AP2057 supplied with each unit.

Whilst we believe the information in this manual to be reliable we do not assume responsibility for inaccuracies. We also reserve the right to make changes in the interest of further product development.

## SERVICE AND TECHNICAL SUPPORT

---

Under normal conditions the **GRI** does not require user maintenance or internal calibration. Any service work required should be carried out by qualified technical personnel only.

We are able to offer further product support through our worldwide distribution network. To help us provide the most efficient service please would you quote the console serial number in any communication regarding this product.

### SAFETY WARNING !

Mains electricity is dangerous and can kill. Mains voltage is present within the **GRI**. Do not remove the top cover with mains connected. Do not carry out any work within the unit while it is powered except for installation calibration. High voltage components are insulated for safety but should not be touched with power applied. The mains voltage setting is factory wired and marked on the rear panel. Check that this matches your local mains supply. Check your mains wiring and earthing before switching on.

#### **DO NOT REMOVE THE MAINS EARTH CONNECTION!**

**The chassis is always connected to mains earth** regardless of any settings of the Ground (earth) Lift option links.

This manual is printed in three sections:

#### **SECTION A**

is a reprint of the **USER GUIDE** for quick reference. This may also assist the service agent in dealing with user related problems. From our experiences with customer problems, most are due to incorrect use or installation of the console and/or connected equipment. This is often due to the customer not reading or misinterpreting the instructions in the user guide.

#### **SECTION B**

provides technical descriptions, service procedures, and how to order spare parts. The contents of the standard service agent spares kits are also listed.

#### **SECTION C**

provides a complete set of circuit diagrams, printed circuit and assembly drawings.

# CONTENTS

## SECTION A

---

INTRODUCTION .....	1
SERVICE & TECHNICAL SUPPORT .....	1
PRECAUTIONS .....	1
INTERCONNECTIONS .....	2
ADJUSTING THE LEVELS .....	2
SPECIFICATION .....	3
CONNECTIONS .....	3
INSTALLATION .....	4
CONNECTING POWER .....	4
FRONT PANEL CONTROLS .....	5
CONFIGURATION .....	6
EARTHING THE AUDIO SYSTEM .....	7
MIC INPUTS .....	7
LINE INPUTS .....	8
CHANNEL DIRECT OUTPUTS .....	8
ROUTING THE CHANNELS .....	9
L,R,M SYS-LINK INPUT/OUTPUT .....	9
MAIN OUTPUTS .....	9
PRIORITY DUCKING SYSTEM .....	10
COMPRESSOR/LIMITERS .....	10
REMOTE CONTROL .....	11
ALARM OVERRIDE .....	12
INPUT EXPANSION WITH SYS-LINK .....	13
OUTPUT EXPANSION WITH SYS-LINK .....	14
BLOCK DIAGRAM .....	15

## SECTION B

---

TECHNICAL DESCRIPTION .....	2
WHEN A FAULT IS SUSPECTED .....	3
REMOVING THE PCB .....	4
VCA CALIBRATION .....	5
ORDERING SPARE PARTS .....	6-7

## SECTION C

---

TECHNICAL BULLETINS .....	2
FRONT & REAR PANEL LAYOUT .....	3
BLOCK DIAGRAM .....	4
INTERNAL LAYOUT .....	5
PCB COMPONENT IDENT .....	6
PCB COMPONENT VALUES .....	7
CIRCUIT DIAGRAMS (11 pages) .....	8-18
AC MAINS VOLTAGE .....	19

# **SECTION A**

**A**

## **GR1 USER GUIDE**

**The user guide is reprinted here for easy reference during service operations.**

## INTRODUCTION

---

The **GRI** continues ALLEN & HEATH's commitment to provide high quality audio equipment engineered to meet the exacting requirements of today's audio business. It brings you the latest in high performance technology and offers the reassurance of over two decades of manufacture and customer support.

This user guide presents a quick reference to the function, application and installation of the **GRI**. For further information on the basic principles of audio system installation and engineering please refer to one of the specialist publications available from bookshops and audio equipment dealers.

Whilst we believe the information in this guide to be reliable we do not assume responsibility for inaccuracies. We also reserve the right to make changes in the interest of further product development.

## SERVICE AND TECHNICAL SUPPORT

---

Under normal conditions the **GRI** does not require user maintenance or calibration. Internal links and preset controls may be set to configure the unit during installation. Any service work required should be carried out by qualified service personnel only.

We are able to offer further product support through our worldwide network of approved dealers and service agents. To help us provide the most efficient service please would you keep a record of the unit serial number, and date and place of purchase to be quoted in any communication regarding this product.

### **SAFETY WARNING !**

Mains electricity is dangerous and can kill. Mains voltage is present within the **GRI**. Do not remove the top cover with mains connected. Do not carry out any work within the unit while it is powered except for installation calibration. High voltage components are insulated for safety but should not be touched with power applied. The mains voltage setting is factory wired and marked on the rear panel. Check that this matches your local mains supply. Check your mains wiring and earthing before switching on.

#### **DO NOT REMOVE THE MAINS EARTH CONNECTION!**

The chassis is always connected to mains earth to ensure your safety. An internal link may be set to remove audio 0V from mains earth (ground lifted) to avoid ground loop problems.

## PRECAUTIONS.

---

- **AC POWER:** Check the rear panel power supply label for the correct AC mains voltage setting.
- **CONNECTIONS:** Use audio connectors and cables only for their intended purpose. Do not connect any source of AC or DC power to the console audio inputs and outputs. Do not connect the output of power amplifiers directly to the console.
- **VENTILATION:** Do not cover the unit in any way. Position the unit in a well ventilated location in the rack.
- **CLEANING:** Avoid the use of chemicals, abrasives and solvents. The control panel is best cleaned with a soft brush and lint-free cloth.
- **LUBRICATION:** The switches and potentiometers are lubricated for life. The use of electrical lubricants on these parts is not recommended.
- **DIRT, DUST, SMOKE and MOISTURE:** Prevent damage to the moving parts, such as switches and potentiometers, and cosmetics by avoiding drinks spillage, tobacco ash and smoke, and exposure to rain and condensation. Protect from excessive dirt, dust, heat and vibration.

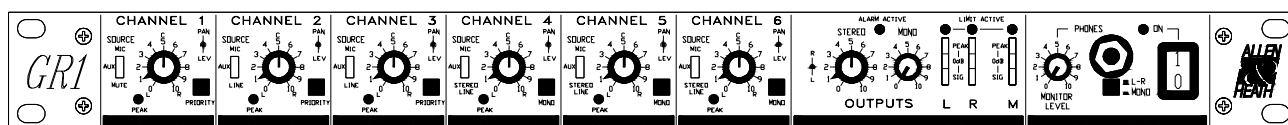

## INTERCONNECTIONS

Where possible use balanced connections for the inputs and outputs to minimise noise pick-up. Avoid running audio cables near to mains or lighting cables or thyristor dimmer units, power supplies etc. These may cause audible hum and buzz. The use of low impedance sources significantly reduces interference pick-up. Check the cables for correct wiring to avoid problems with phase reversal and unreliable connection. The **GRI** follows the convention for XLR pin 2 and jack tip = signal hot (+). Always use balanced cables when connecting to phantom powered microphones.

**MAKE SURE THAT +48V IS DISABLED USING THE INTERNAL LINK OPTIONS WHEN THE CHANNEL INPUT XLRS ARE CONNECTED TO NON-PHANTOM POWERED OR LINE SOURCES.**

If ground loops cause problems connect the cable screen at one end only as described below. Balanced outputs may be connected to unbalanced inputs and vice versa by linking the signal cold (-) to 0V ground as follows:

- ◆ Balanced output to Balanced input - Connect cable screen at destination only using the output XLR pin 1 ground lift internal option link.
- ◆ Balanced output to Unbalanced input - Connect screen at source only. Link the -ve output to 0v at the output connector.
- ◆ Unbalanced output to Balanced input - Connect cable screen at destination only using the output XLR pin 1 ground lift internal option link. Link the -ve input to 0V at the input connector.

## ADJUSTING THE LEVELS

For best performance it is important that the audio signal levels are adjusted for “normal operating level”. If too high the signal peaks will be clipped resulting in a harsh distorted sound, and if too low the signal-to-noise ratio is reduced resulting in excessive background hiss.

For best results operate the unit with the output meters averaging ‘0’. This gives a nominal internal operating level of -2dBu with ample headroom of +23dB to allow for the peaks. The corresponding XLR output level may be set to one of three standard line levels: -10dBV (300mV low level), 0dBu (0.775V), +4dBu (high level). The 1/4" jack line inputs may also be set to one of these three levels. The XLR MIC inputs may be set to match the connected source by adjusting the rear panel gain trimmers. A 20dB attenuator pad may be enabled by setting the internal link options for high output microphones or line level sources. The **GRI** offers comprehensive signal level checking. Each channel includes a PEAK indicator which shows signal peaks 5dB before clipping. Reduce the gain trim setting or set the line inputs for a higher operating level if the indicator flashes continually. The signal quality and level of a single channel may be checked by setting its level control fully on (clockwise) and the other channels off. Adjust the gain for an average '0' reading on the output meter. If only the output PEAK indicators flash when several channels feed the mix then reduce the overall channel levels.

**SPECIFICATION**

0 dBu = 0.775 Volts RMS  
 0 dBV = 1 Volt RMS  
 Line level options: +4dBu (high level), 0dBu, -10dBV (300mV low level)

INTERNAL OPERATING LEVEL: -2 dBu  
 INTERNAL HEADROOM: ..... +23 dB  
 MAX OUTPUTS:..... balanced +26 dBu 600 ohms max load  
 unbalanced +21 dBu 2kohms max load

METERS:..... Individual bargraphs for L,R,M  
 -20VU (signal), 0VU, +16VU (peak)  
 PEAK LEDs: ..... Turn on 5dB before clipping

DUCKING: ..... Signal override system.  
 Depth -6dB, -12dB 0r -18dB (internal option)  
 Release fast or slow (internal link)  
 Controlled by CH1,2,3 PRIORITY switches  
 Individual channel ducking disable (internal option)

COMPRESSOR/LIMITERS: ..... L,R,M individually controlled  
 Ratio 2:1, 4:1, 10:1 (internal option)  
 Threshold -30dB to +15dB (internal preset)

Width ..... 19.0" standard 19" rack ..... (540mm)  
 Height ..... 1.75" 1U rack space ..... (130mm)  
 Depth ..... 10.3" ..... (390mm)  
 weight ..... 10lbs ..... (4.5kg)  
 packed ..... 11lbs ..... (5kg)

CONSTRUCTION: All metal chassis.  
 Standard 19" rack mount in 1U space.  
 Removable top cover for calibration and service access.  
 Internal power supply unit with low radiation toroidal transformer.

FREQUENCY RESPONSE: 20Hz to 30kHz +0/-1dB

DISTORTION: THD 0.04% Line in to mix out at 1kHz

CROSSTALK: . Channel shutoff better than -90 dB at 1kHz  
 Channel pan better than -75 dB at 1kHz  
 Interchannel better than -80 dB at 1kHz

NOISE: ..... 22Hz to 22kHz  
 MIC EIN -128 dB into 150 ohms  
 LINE pre-amp at 0dB -89 dBu  
 MIX noise -80 dBu

POWER REQUIREMENTS: 50/60Hz 25VA max  
 Mains voltage factory set for local requirements.  
 Mains input protection fuse ..... T315mA (220-240V)  
 T630mA (100-120V)

EMERGENCY DC POWER BACKUP:  
 External DC power supply or batteries.  
 +/-12 to 16VDC at 300mA  
 +12 to +48VDC microphone phantom power.

PHANTOM POWER: +48V DC  
 Global +48V ON switch, individual channel disable links.

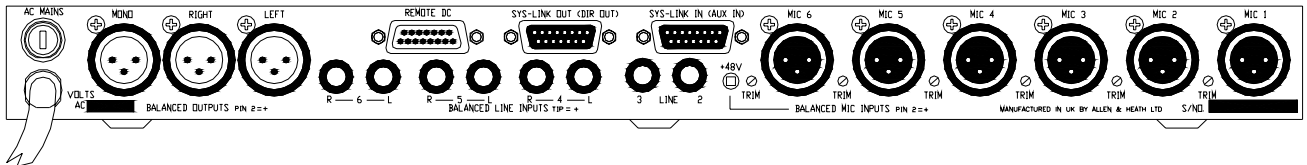

**CONNECTIONS**

**INPUTS:**  
 MIC IN ..... XLR ..... pin 2 hot, 3 cold balanced ..... 2k ohms ..... variable -55 to -12dBu  
 ..... LINE (pad selected) .. pin 2 hot, 3 cold balanced ..... 10k ohms ..... variable -35 to +8dBu  
 MONO LINE IN ..... 1/4" JACK ..... tip hot, ring cold balanced ..... 10k ohms ..... -10dBV, 0dBu, +4dBu  
 STEREO LINE IN ..... 1/4" JACKS ..... tip hot, ring cold balanced ..... 10k ohms ..... -10dBV, 0dBu, +4dBu  
 AUX IN (SYS-LINK) ..... 15way D female ..... unbalanced ..... 10k ohms ..... -2dBu  
 ALARM IN (SYS-LINK) .. 15way D female ..... unbalanced ..... 10k ohms ..... -2dBu  
 ALARM DC (SYS-LINK) 15way D female ..... opto-coupled ..... link to 0V to enable  
 REMOTE VCA DC IN .... 15way D male ..... +10V = level max, 0V = channel off  
 BACKUP DC IN ..... 15way D male ..... main supply +/-12 to +/-16V DC phantom power +12 to +48V DC

**OUTPUTS:**  
 L, R, M OUT ..... XLR ..... pin 2 hot, 3 cold balanced ..... 50 ohms ..... -10dBV, 0dBu, +4dBu  
 DIRECT (SYS-LINK) ..... 15way D female ..... unbalanced ..... 50 ohms ..... -2dBu  
 L, R, M (SYS-LINK) ..... 15way D female ..... unbalanced ..... 50 ohms ..... -2dBu  
 ALARM OUT (SYS-LINK) 15way D female ..... unbalanced ..... 50 ohms ..... -2dBu  
 ALARM DC (SYS-LINK) 15way D female ..... opto-coupled ..... link to 0V to enable  
 HEADPHONES OUT ..... 1/4" jack ..... tip L, ring R ..... for stereo headphones 8 to 400 ohms  
 REMOTE VCA DC REF 15way D male ..... +10V, 0V reference voltage for remote VCA control

## INSTALLATION

The **GRI** fits into a 1U space in a standard 19" rack system. Alternatively the unit may be mounted into a cabinet or plinth, or simply used free standing.

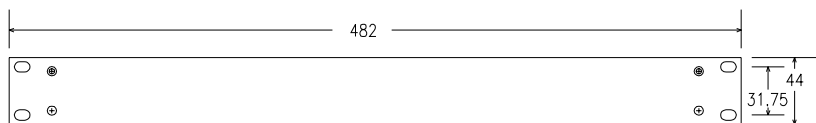

Dimensions shown are case size in millimeters. Allow extra space as necessary for the front controls (add 26mm) and for the rear connectors.

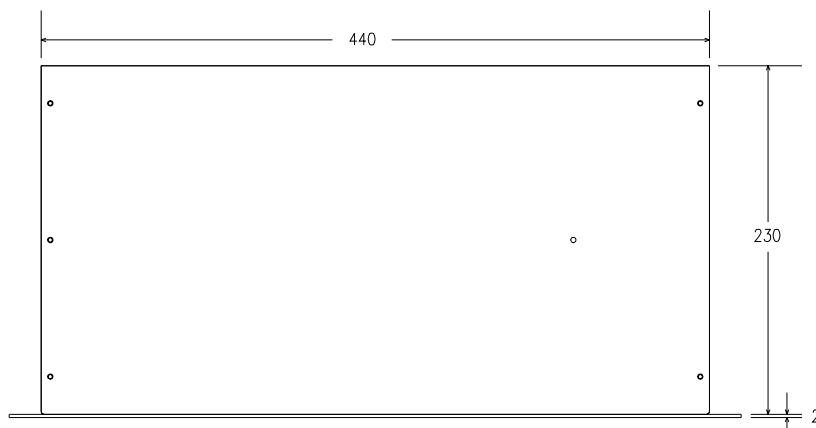

Mount the console using 2x M6 bolts each side for maximum strength. These should be provided by the supplier of the rack kit.

The rack should allow a minimum side to side opening of 445mm.

Provision should be provided for removal of the top cover for access to the internal configuration links.



### PRECAUTION !

**TO AVOID DAMAGE TO THE INTERNAL ASSEMBLIES DO NOT FIT SCREWS THROUGH SIDES OR UNDERSIDE OF THE CONSOLE. SECURE TO EXTERNAL BRACKETS OR FITTINGS THROUGH THE FRONT PANEL RACK MOUNTING HOLES.**

## CONNECTING POWER

A 1.7 meter long captive power cord with fitted plug connects the **GRI** to mains power. Check that the rear panel indicates the correct setting for the local mains supply, and that the correct mains plug is fitted. The unit may be supplied wired for 100, 110, 120, 220, or 240V.AC. The rear panel mains protection fuse is a standard 20x5mm antisurge type T315mA for 220-240V or T630mA for 100-120V.AC.

An emergency DC backup supply may be connected so that the unit remains powered in the event of a mains supply failure. This switches in automatically when the internal DC supply voltages fall below the level of the connected backup source. The front panel ON indicator always shows when the unit is powered either from mains or the backup supply.

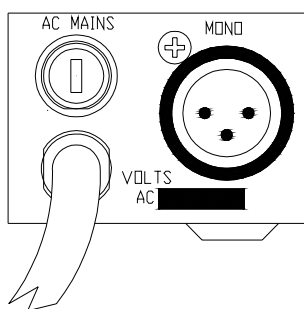

**MAINS INPUT**

### DC BACKUP SUPPLIES

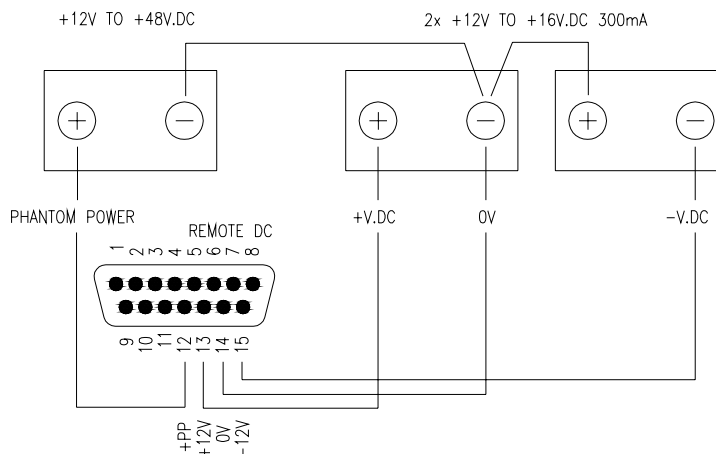



## CONTROL FUNCTION

### input section

**LEV & PAN**  
The top control adjusts the signal level to the L, R, & M mix. The lower control adjusts the position in the stereo image. In the centre click position, the L & R have equal signal levels.

**SOURCE**  
The 3 way lever switch selects either MIC, AUX(OFF) or LINE inputs.

**PEAK**  
The peak indicator illuminates when the channel signal approaches overload.

**PRIORITY**  
Selecting priority on a channel reduces the signal levels of the other channels.

**MONO**  
Selecting mono combines the AUX or LINE left & right input signals.

### master section

**LIMIT ACTIVE**  
Indicators illuminate when compressor/limiters are active.

**PHONES**  
For headphone monitoring the main output signals.

**ALARM ACTIVE**  
Indicates the alarm status of the unit.

**MONITOR LEVEL**  
Adjusts the PHONES signal level.

**ON**  
Indicates power to the unit either AC mains or external DC in.

**STEREO**  
Adjusts the output level of the main L & R signals.

**MONO**  
Adjusts the output level of the mono signal.

**METERS**  
Used for signal level checking.

**L-R / MONO**  
Selects the PHONES signal source.

# CONFIGURATION

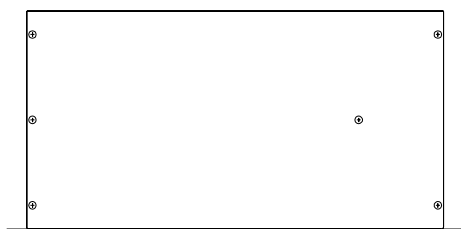

Remove the 6 crosshead screws securing the top cover to the chassis. Lift off the cover to gain access to the options. Apply caution if powering the unit with the cover removed.

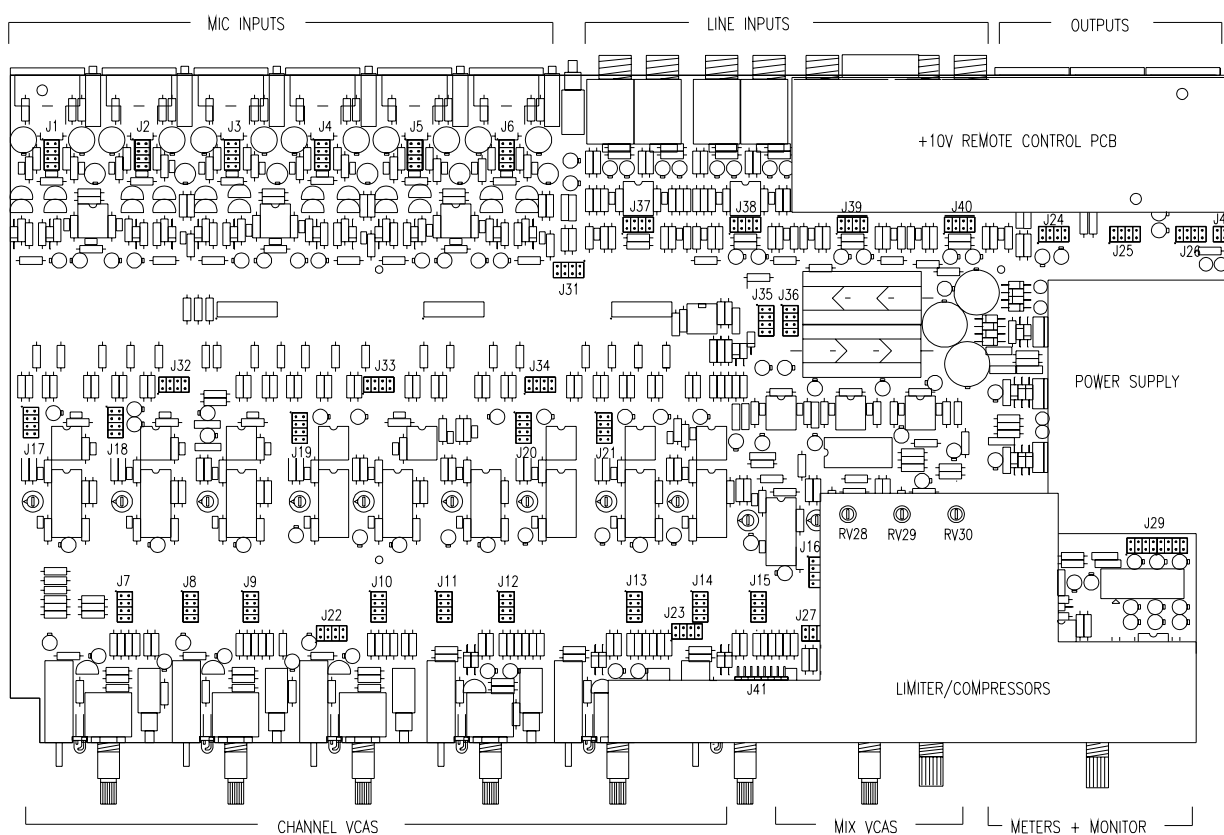

The GR1 offers unique flexibility in its ability to be configured to satisfy the exact requirements of each installation. This is done by setting internal jumper links and calibration trimmers which determine the operating levels, signal routing, and mode of operation of the ducking, alarm and compressor/limiter systems. These are accessed by removing the top cover. The option link layout is shown above and in the system block diagram. Once installed the settings become tamperproof and only the front panel controls are available to the user making the unit extremely easy to operate.

Configuration should only be carried out by a competent installation engineer. Apply caution when powering the unit with the top cover removed. Only the compressor/limiter threshold trims may need adjustment with power applied. The following pages detail the installation options.

## EARTHING THE AUDIO SYSTEM

The chassis is connected to mains earth via the power cord. **FOR SAFETY REASONS NEVER REMOVE THE EARTH WIRE FROM THE MAINS PLUG.**

Multiple earth paths cause earth (ground) loops which may result in audible hum and interference. These may be avoided by making sure that there is only one path to earth from each piece of equipment. An internal link option is available for each XLR output to disconnect 0V from the pin 1 cable screen if necessary.

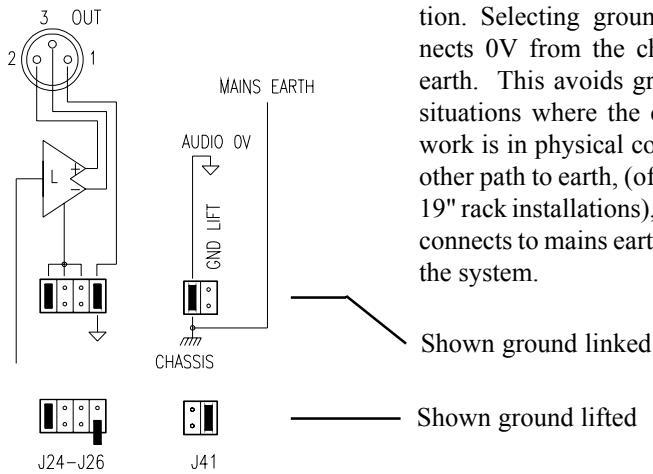

Audio 0V is connected to mains earth by the internal ground lift link option. Selecting ground lift disconnects 0V from the chassis (mains) earth. This avoids ground loops in situations where the chassis metalwork is in physical contact with another path to earth, (often the case in 19" rack installations), or if audio 0V connects to mains earth elsewhere in the system.

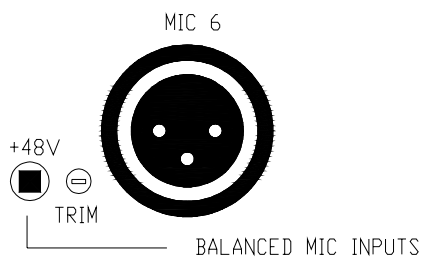
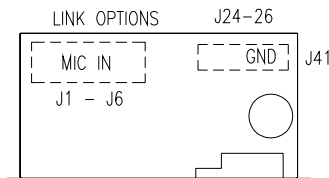

## MIC INPUTS

6 electronically balanced XLR inputs each with a high performance pre-amplifier and option links:

### GAIN CALIBRATION TRIMMER

20-turn preset trimmer accessible with a trim tool or small screwdriver through the rear panel. Matches a wide range of microphone levels to the operating level of the unit. Adjust with the channel level control fully clockwise for an output meter reading averaging '0dB'. Reduce the trim level if the channel PEAK indicators flash.

### OPTION LINK - +48V PHANTOM POWER DISABLE

Remove link (set on one pin) to disable the internal +48V phantom power supply from the XLR. Always disable +48V when connecting to non-phantom powered microphone or line level sources. The rear panel +48V switch turns on phantom power to all enabled XLR inputs when pressed.

### OPTION LINK - 20dB PAD

Remove 2 links (set on one pin) to enable the 20dB attenuator pad when connecting to high output microphones or mono line level sources.

### OPTION LINK - LO-CUT FILTER

Remove link (set on one pin) to enable the lo-cut filter to reduce low frequency interference such as microphone proximity noise, rumble and hum. This reduces frequencies below 70Hz.

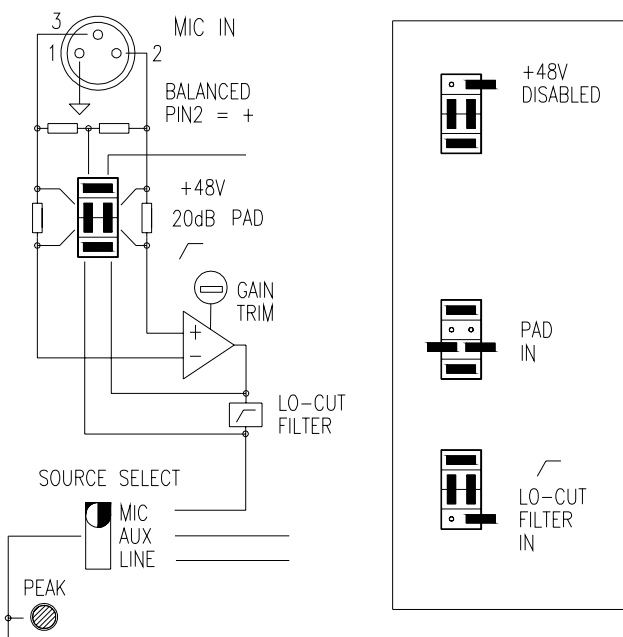

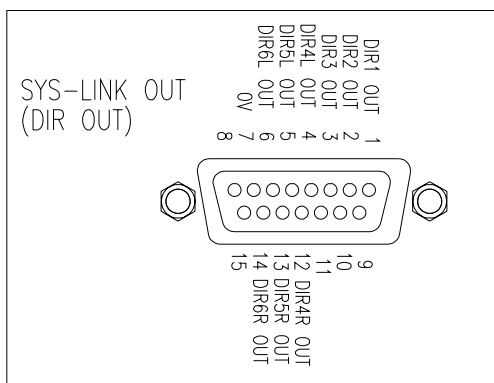
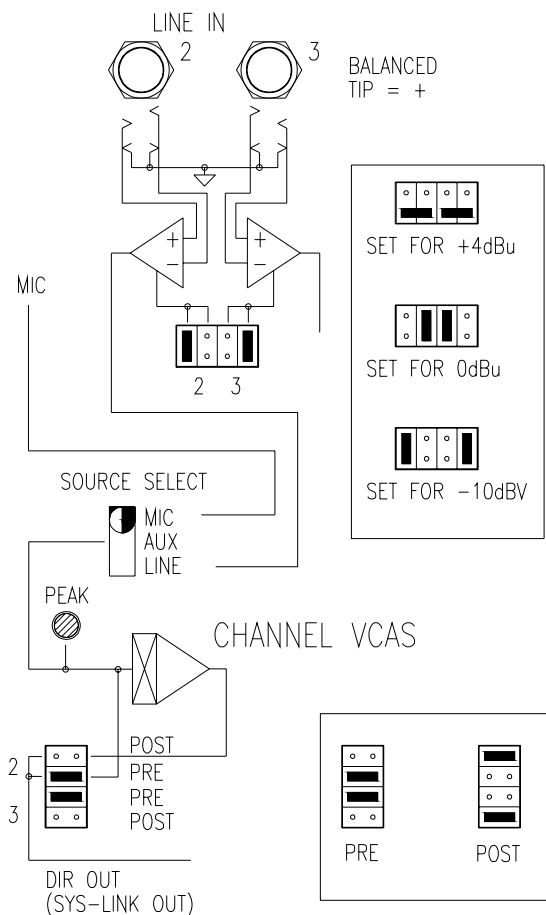
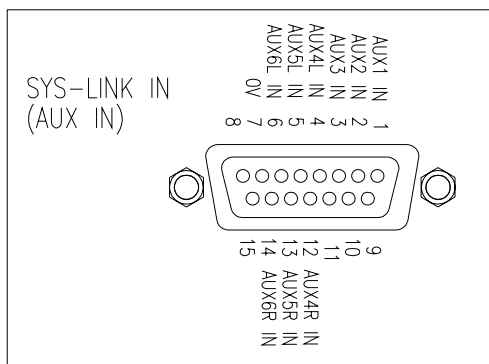
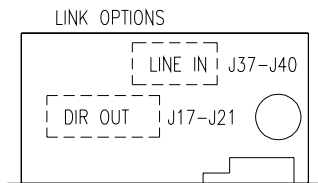

## LINE INPUTS

### MONO AND STEREO LINE INPUTS

2 Mono and 3 stereo electronically balanced line inputs are available on 1/4" jack sockets. The stereo inputs provide individual sockets for left and right inputs.

### OPTION LINKS - LINE INPUT LEVEL

Unbalanced sources may be plugged into these inputs. The inputs may be individually internally set for one of three standard operating levels by positioning the jumper links as shown. Note that two line inputs are set on one bank of links.

+4dBu (1.2Vrms)	High level
0dBu (0.775Vrms)	Line level
-10dBV (300mVrms)	Low level

### MONO AND STEREO AUX INPUTS

An additional 2 mono and 3 stereo unbalanced line level AUX inputs are available on the SYS-LINK IN connector. These operate at -2dBu (600mVrms). The AUX inputs may be used for extra line inputs switchable from the front panel, or for expansion of the system using SYS-LINK.

## CHANNEL DIRECT OUTPUTS

Line level unbalanced Direct Outputs for each input are available on the SYS-LINK OUT connector. These operate at -2dBu (600mVrms). The DIR outputs may be used to feed additional zones, monitors, recording devices etc, or to expand the system using SYS-LINK.

### OPTION LINKS - PRE/POST DIRECT OUTPUTS

Each DIR output may be taken from the output of the input pre-amplifier before (pre) or after (post) the channel level control. PRE may be used to feed the channel signals to additional **GR1** units for zone expansion, or for signal monitoring. POST may be used for recording feeds, effects sends etc. Two channels are set on one bank of links. Note that the inner links set PRE and the outer links set POST.

## ROUTING THE CHANNELS TO THE OUTPUTS

Each of the 6 channels may be routed as required to a combination of the 3 outputs L, R and M to feed up to 3 mono zones or one stereo and one mono zone. The L and R post level outputs may also be routed to the M output for situations where a L+R sum is required. Note that the channel inputs may be summed with L+R to provide an independent mix based on the L and R outputs.

### OPTION LINKS - CHANNEL ROUTING

Select the inner jumper links for routed signals, outer links for not routed.

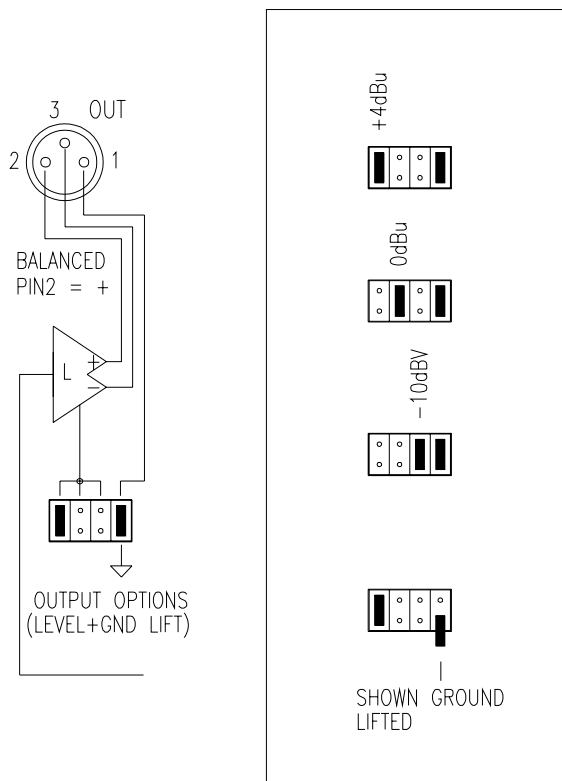
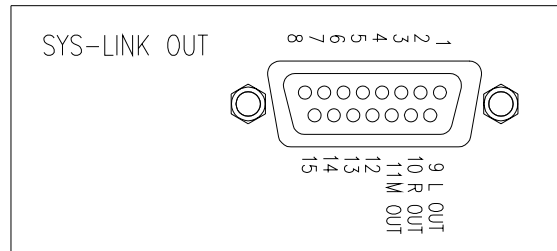
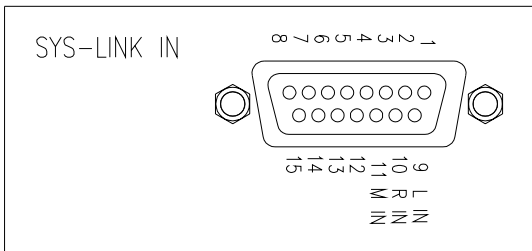
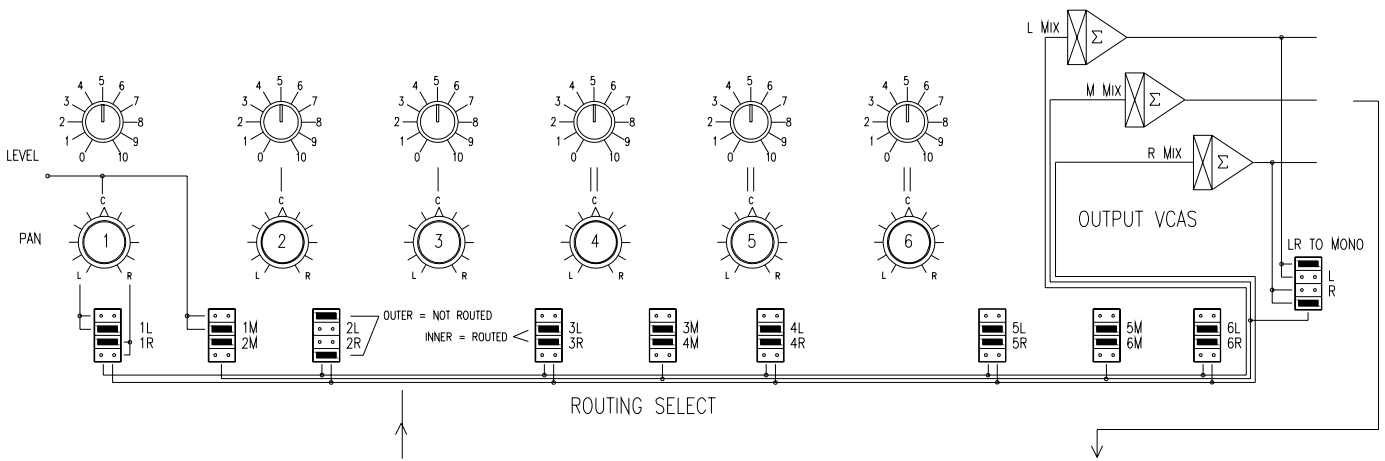
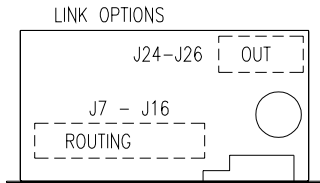

## L,R,M SYS-LINK INPUTS/OUTPUTS

The L, R and M outputs are also available on the SYS-LINK OUT connector. Inputs are available on the SYS-LINK IN connector. These operate unbalanced at -2dBu (600mVrms) and may be used as additional mix inputs and outputs or to expand the system using SYS-LINK.

## MAIN OUTPUTS

The main L, R and M outputs are available on electronically balanced line level 3-pin XLR male connectors.

### OPTION LINKS - LINE OUTPUT LEVEL

These may be individually set for one of three standard operating levels by positioning the jumper links as shown.

+4dBu (1.2Vrms)	High level
0dBu (0.775Vrms)	Line level
-10dBV (300mVrms)	Low level

### OPTION LINKS - OUTPUT XLR GROUND LIFT

Set the jumper as shown to connect or disable XLR pin 1 from audio 0V for optimum system grounding to avoid problems with ground loops.

## PRIORITY DUCKING SYSTEM

The **GR1** offers a flexible ducking system that allows one or a combination of the 3 mono channels to duck (override) the level of the other channels by reducing their level by a pre-determined amount. For example this may be used for voiceover announcements where the background music is dimmed by the microphone signal level. The channel or channels that cause the ducking are selected by pressing the front panel PRIORITY switches. The selected channels are themselves disabled from ducking when this switch is pressed. Any channel may be disabled from ducking by setting the internal jumper link.

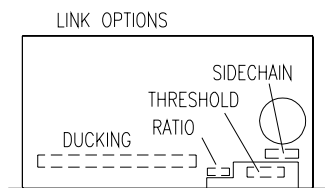

OPTION LINKS - **INDIVIDUAL DUCKING DISABLE FOR CH1 TO 6**

OPTION LINKS - **DUCKING DEPTH AND RELEASE TIME**

Select the required amount of ducking effect: -6dB, -12dB, -18dB. The time taken for the ducked signal to return to normal level is set by the FAST/SLOW link.

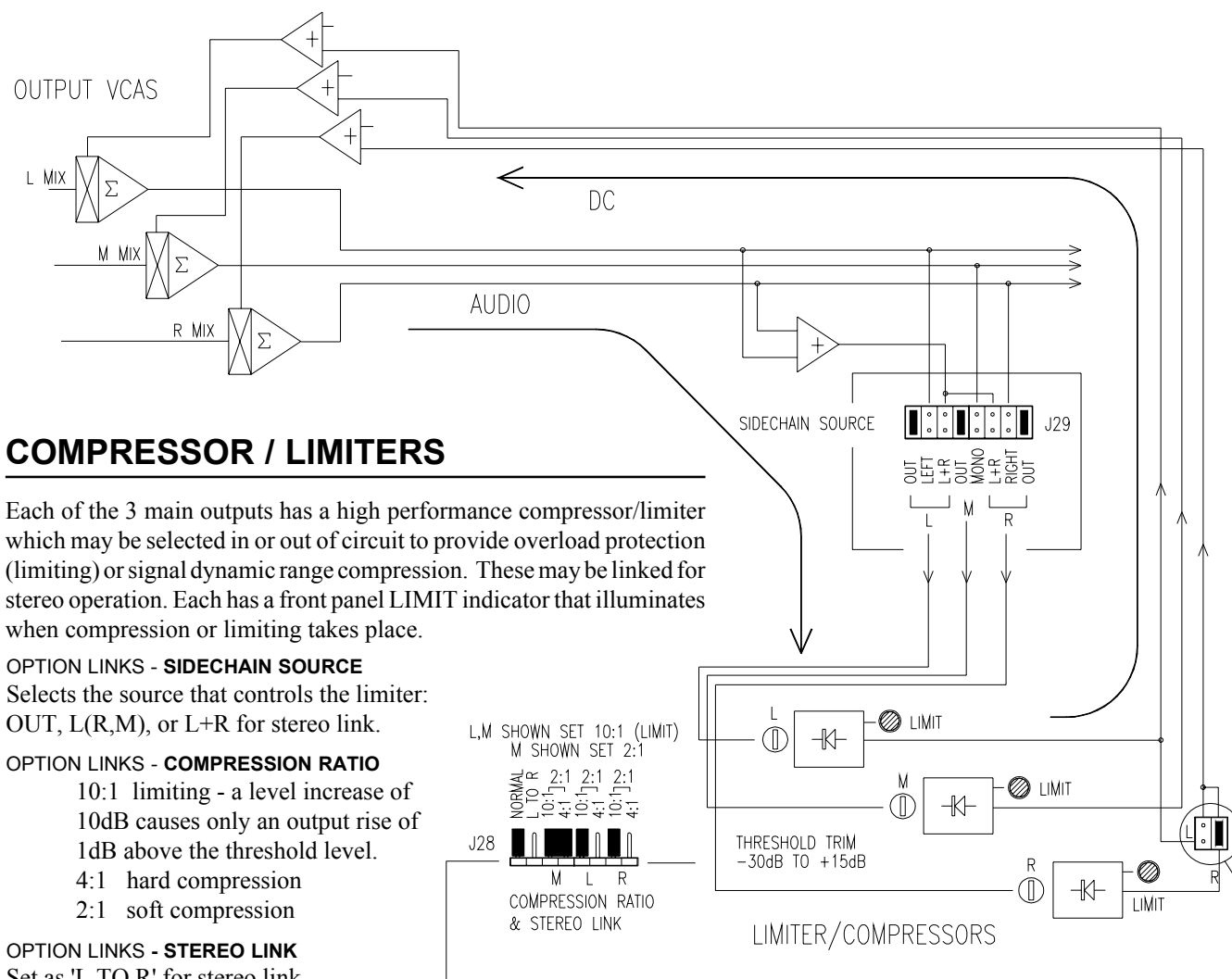
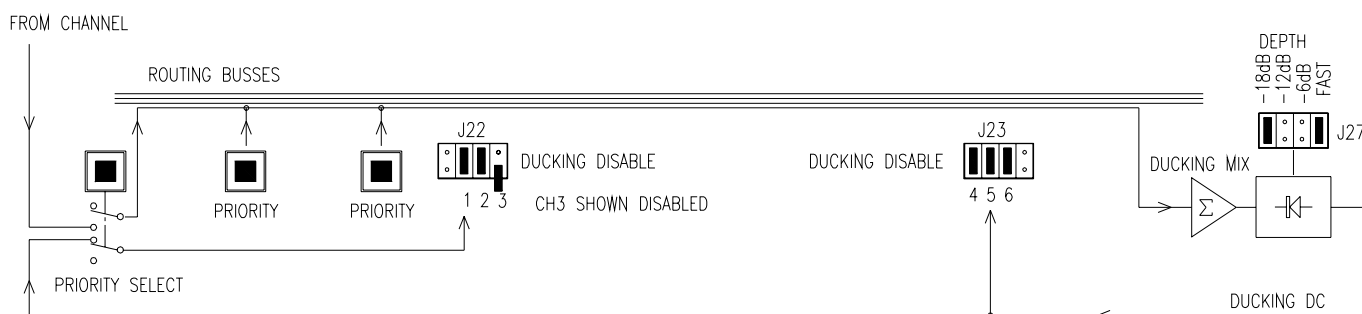

## COMPRESSOR / LIMITERS

Each of the 3 main outputs has a high performance compressor/limiter which may be selected in or out of circuit to provide overload protection (limiting) or signal dynamic range compression. These may be linked for stereo operation. Each has a front panel LIMIT indicator that illuminates when compression or limiting takes place.

OPTION LINKS - **SIDECHAIN SOURCE**

Selects the source that controls the limiter: OUT, L(R,M), or L+R for stereo link.

OPTION LINKS - **COMPRESSION RATIO**

10:1 limiting - a level increase of 10dB causes only an output rise of 1dB above the threshold level.

4:1 hard compression

2:1 soft compression

OPTION LINKS - **STEREO LINK**

Set as 'L TO R' for stereo link.

OPTION TRIMMER - **THRESHOLD LEVEL**

Sets the level at which compression or limiting occurs. From -30dB to +15dB.

## REMOTE CONTROL OF THE LEVELS

Each of the 6 channels and the main L,R and M outputs are fed through high performance VCA (voltage controlled amplifier) circuits. These are controlled individually either by the front panel level controls or by external DC voltages connected to the REMOTE DC connector according to the setting of the internal jumper links as shown below.

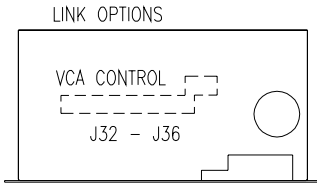

Control Voltages are:

**+10V DC = channel fully on**

**0V = channel off**

A buffered +10V DC reference voltage is provided on the REMOTE DC connector. This may be connected to a potentiometer for remote level control. The recommended potentiometer is 10K ohms reverse (antilog) logarithmic.

Use screened cable to minimise interference pickup.

NOTE: Any references to control voltages of 0V to -9V should be substituted with the above.

### LINK OPTIONS

#### INT/EXT DC CONTROL

The inner links set internal front panel level control, the outer links set external level control.

#### +10V DC INT/EXT VOLTAGE

The +10V DC voltage can be derived internally or externally by setting the link on the remote connector circuit board.

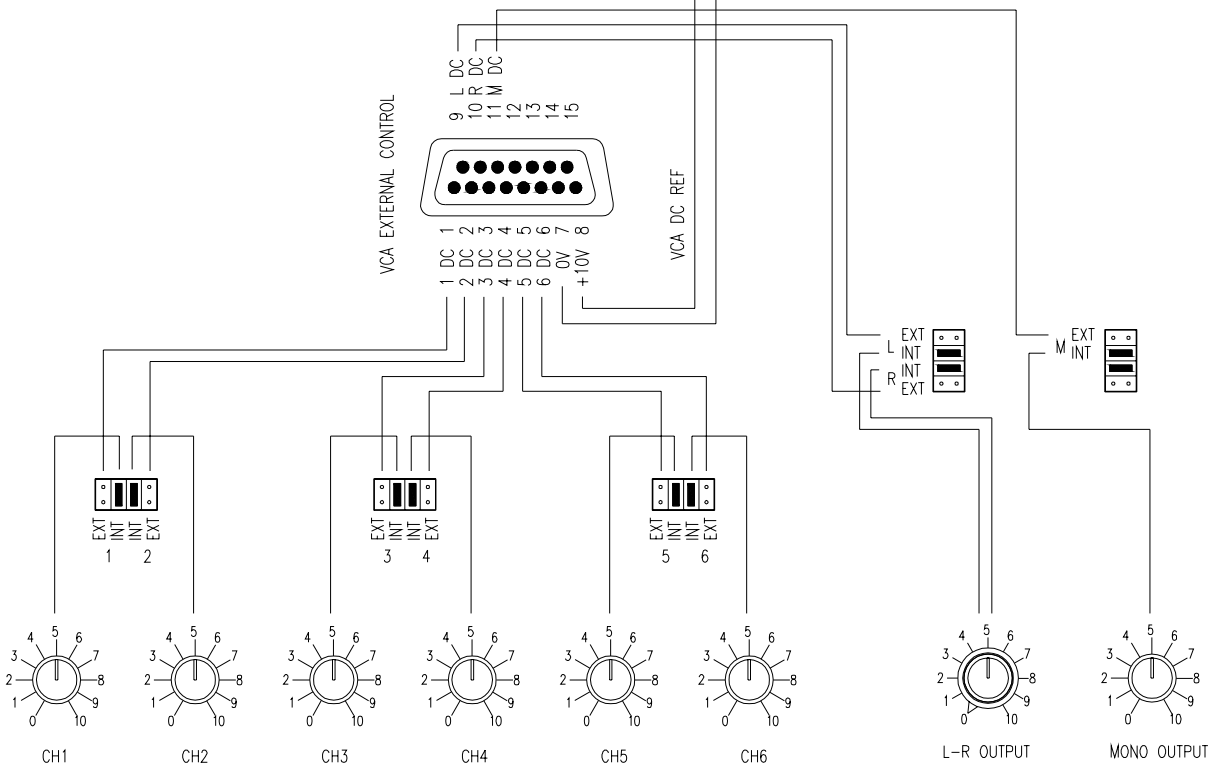
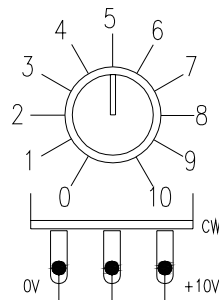

## ALARM OVERRIDE

To allow automatic control of the system by an alarm recording or emergency announcement the **GR1** includes a comprehensive alarm override feature. When activated the front panel ALARM ACTIVE LED lights and the 3 main outputs are automatically switched to the selected alarm audio source. This is selected by internal jumper links to be the ALARM AUDIO IN on the SYS-LINK IN connector or the local MIC 6 input.

The alarm system is activated when the opto-coupled ALARM DC connection is linked to 0V. This may be done by a switch or external logic system.

Control states are: **+15V (open circuit) = normal output**  
**0V (link to 0V) = alarm active**

### LINK OPTIONS - ALARM SOURCE

Selects either the external alarm input or local MIC 6 as the local alarm source and feed to other **GR1** units within a SYS-LINK connected system.

Connect a nominal -2dBu line level unbalanced signal to ALARM IN

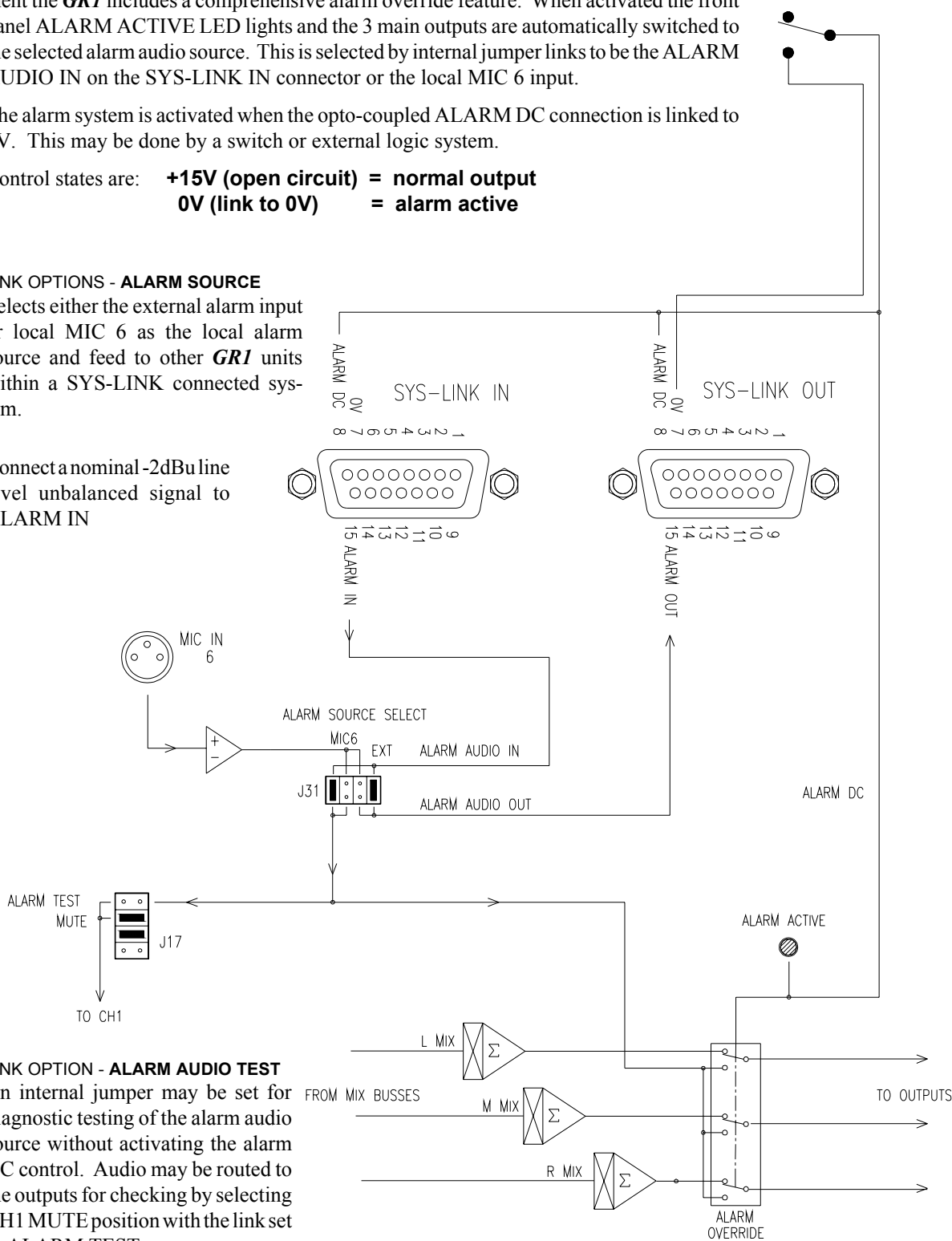

### LINK OPTION - ALARM AUDIO TEST

An internal jumper may be set for diagnostic testing of the alarm audio source without activating the alarm DC control. Audio may be routed to the outputs for checking by selecting CH1 MUTE position with the link set to ALARM TEST.

The alarm signal is switched directly before the main outputs and is not affected by the compressor/limiters or output level control. Combined with the automatic power backup feature this provides a complete and foolproof emergency system.



## EXPANDING THE INPUTS WITH SYS-LINK

The number of input channels feeding the outputs may be expanded by connecting **GRI** units together using the SYS-LINK system. A single cable connects the L,R and M outputs of one unit to the buss inputs of the next.

Use screened multiway cable connected as shown below to standard 15way D-type male connectors. Do not interconnect the DIR OUTs to the AUX INs when linking L,R and M outputs. The example shown below includes interconnection of the alarm override system so that one alarm source controls all units simultaneously.

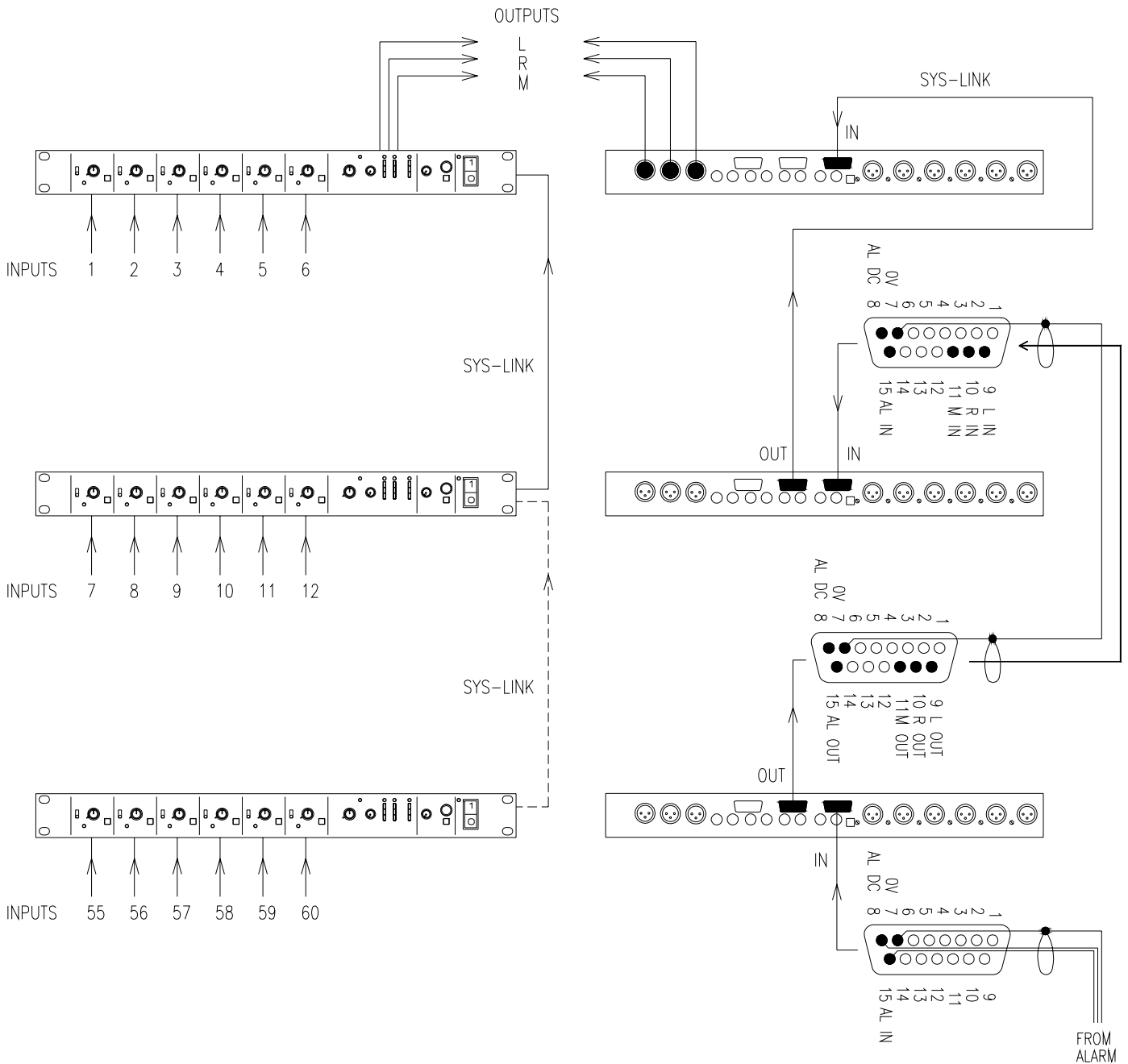

For output level control at the master unit only disable the L,R and M output level controls on the slave units by removing the INT/EXT links J35 and J36.

## EXPANDING THE OUTPUTS WITH SYS-LINK

The number of outputs may be expanded by connecting **GRI** units together using the SYS-LINK system. This may be used to provide more zone feeds from the 6 input channels. A single cable connects the 6 channel DIR outputs of one unit to the AUX inputs of the next.

Use screened multiway cable connected as shown below to standard 15way D-type male connectors. Do not interconnect the L,R and M outputs to the L,R and M buss inputs when linking the channels. The example shown below includes interconnection of the alarm override system so that one alarm source controls all units simultaneously.

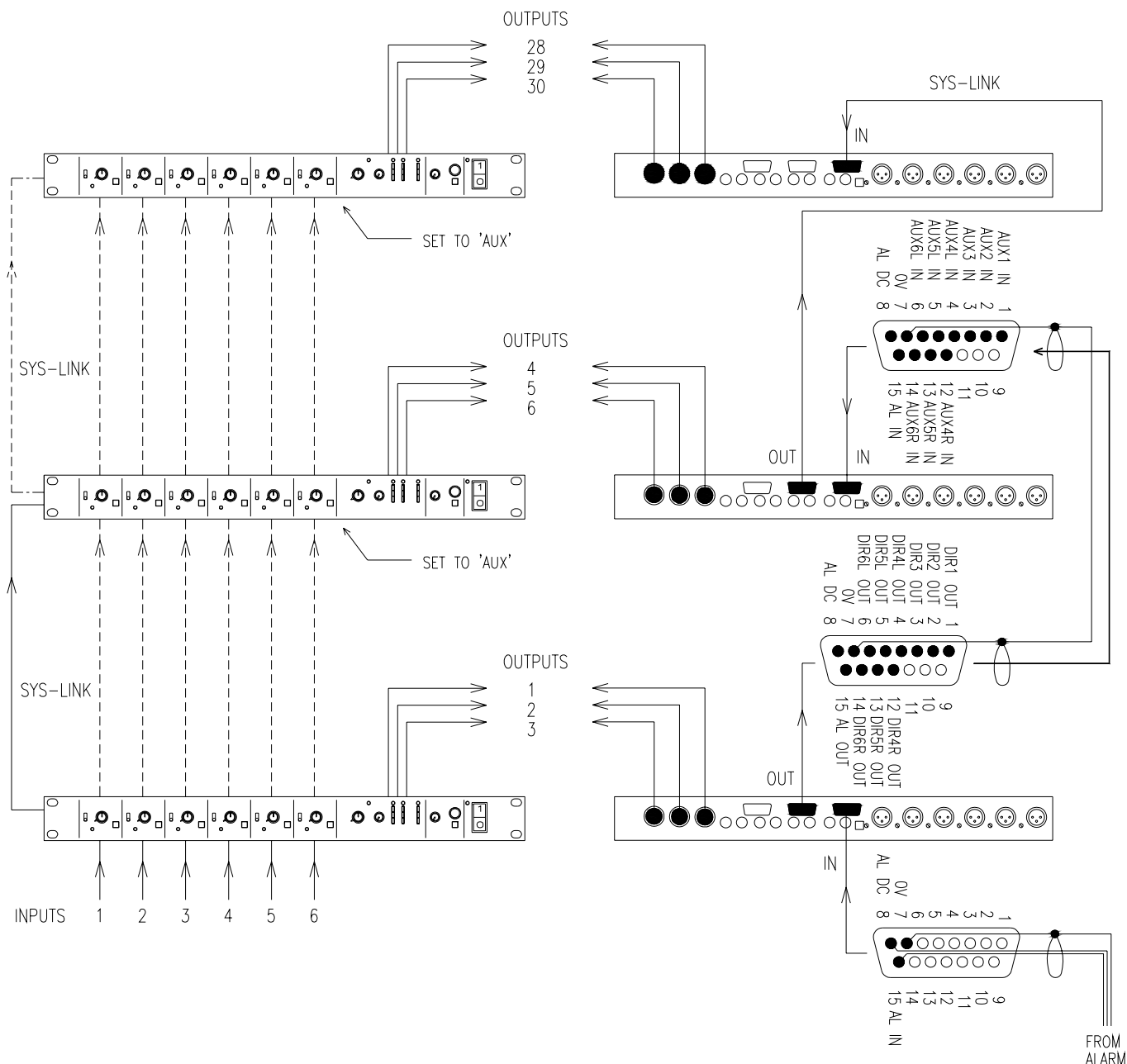

Set the slave unit channel selector switches to 'AUX'. This selects the corresponding signal from the master unit. The DIR OUT pre/post links J17 - J21 should be set to the 'pre' position so that the local level controls do not affect the feeds to the other units.

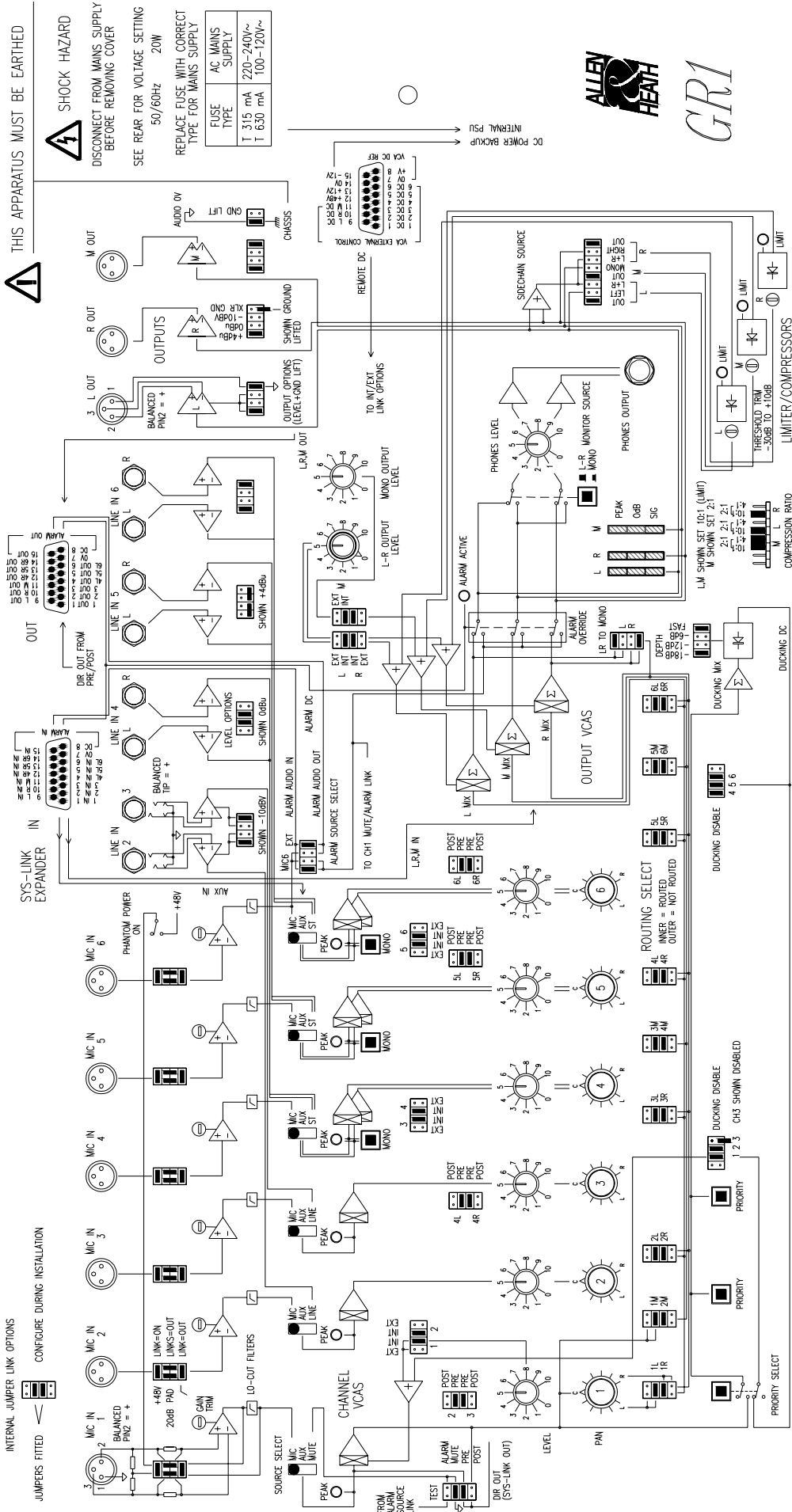

THIS APPARATUS MUST BE EARTHED

**SHOCK HAZARD**  
DISCONNECT FROM MAINS SUPPLY BEFORE REMOVING COVER

SEE REAR FOR VOLTAGE SETTING 50/60Hz 20W

REPLACE FUSE WITH CORRECT TYPE FOR MAINS SUPPLY



INTERNAL JUMPER LINK OPTIONS  
JUMPERS FITTED < CONFIGURE DURING INSTALLATION

# **SECTION B**

**B**

## **SERVICE PROCEDURES**

### **CAUTION !**

**TO AVOID DAMAGE TO INTERNAL COMPONENTS BY MISHANDLING AND/OR MISCONNECTION, ONLY TECHNICALLY COMPETENT PERSONNEL SHOULD ATTEMPT SERVICE WORK ON THIS CONSOLE.**

# TECHNICAL DESCRIPTION

The ALLEN & HEATH *GRI* has been designed to cater for the sound distribution requirements of Clubs, Pubs, Theatres, Hotels, Conference Facilities and Government Institutions. It conforms to all the necessary Health and safety requirements to British standards. The design has been successful in achieving an extremely easy to use compact unit. Operation requires no technical knowledge - all critical options are internal and tamper proof.

## CONSTRUCTION

---

All metal chassis for rack mounting in a 19" by 1U space. The unit comprises of a 14swg steel front panel with a 16swg steel chassis and separate top cover. The connectors are rear mounted for easy access in rack or plinth mounted applications. Access to the internal assembly is by removal of the top cover. All components are mounted on two printed circuit assemblies, the only exceptions being the AC mains components. The power supply is internal with access to the fuse from the rear panel. The *GRI* is designed for rack or plinth mounting,

## THE CIRCUIT COMPONENTS

---

The *GRI* is manufactured using high performance industry standard linear op-amp, VCA, logic gate and discrete semiconductor circuit devices. In particular the switches and potentiometers have proven to be durable and problem free. When operated correctly the normal performance of the unit introduces no noticeable audio signal degradation.

## THE POWER SUPPLY AND CONSOLE EARTHING

---

The *GRI* uses a universal low noise regulated linear DC supply system for all amplifier, logic and indicator subsystems. The internal power unit operates from single phase 50/60Hz AC mains input to provide the three regulated DC outputs +16V (0.5A), -16V (0.5A), +48V (0.05A). The +/-16V supplies are filtered into separate feeds for the audio and logic/indicator circuits on the circuit board assemblies. A high quality low radiation toroidal transformer is wired to suit the local AC mains supply voltage: 100, 110, 120, 220, or 240 V.AC. The power unit **ON** indicator monitors the +/-16V.DC voltage supplies post regulators. During a mains supply failure the *GRI* may be powered from an external DC source by connecting the supply to the relevant pins on the REMOTE connector on the rear panel. A ground (earth) lift link (J41) is provided on the main PCB assembly (see USER GUIDE) to isolate the console audio 0V from mains earth. This is to avoid earth loops in situations where multiple earth paths are present e.g. in 19" racks where the chassis is in contact with earthed rack metalwork. **THE CHASSIS METALWORK IS ALWAYS CONNECTED TO MAINS EARTH VIA THE EARTH WIRE IN THE MAINS PLUG. DO NOT REMOVE THE EARTH WIRE CONNECTION IN THE MAINS PLUG !** The *GRI* audio performance is optimised by using an internal distributed earthing system that separates audio and logic earths.

## AUDIO INPUTS AND OUTPUTS

---

The channel mic and line inputs, and the L-R and Mono outputs are electronically balanced (differential). The SSM2142 differential output driver is used to balance the outputs. To use these with unbalanced equipment the -ve signal should be linked to 0V in the cable or input connector. All outputs are low impedance and thus capable of driving several high impedance inputs simultaneously. All inputs and outputs are in phase.

## WHEN A FAULT IS SUSPECTED ...

---

The *GRI* is an integral part of a typical audio installation, providing the link between microphones, other sound sources, amplifiers etc. through a "highway" of interconnecting cables carrying audio signals, DC power and AC mains voltages. If a problem is reported it is often assumed that the *GRI* is at fault. Our experience has shown that most reported problems are related to faulty cables, equipment matching, control settings, or faulty external equipment, and not to the *GRI* itself which is designed for continued fault-free performance with no user maintenance. It is usual only to replace worn out electro-mechanical parts such as switches and potentiometers.

When a problem is reported it is necessary to isolate the location of the fault within the system. Only when tests have been made to eliminate faults in equipment and in the connecting cables to the *GRI*, should you attempt to repair or report the unit as faulty.

Note that only technically competent personnel should attempt service work on the *GRI*. Check also the validity of the manufacturers or selling agents warranty. Always quote the console serial number when reporting a fault.

If the console is to be sent by carrier we advise that you check the packing for suitability first. Use the purpose designed ALLEN & HEATH packing if it is still intact.

## IDENTIFYING THE FAULT

---

Fault diagnosis is often carried out by telephone with the user who is often non-technical and needs to be talked through a series of simple tests to identify the symptoms and locate the problem. These include substitution of cables and equipment inputs and outputs. If the *GRI* is still suspected as faulty it is recommended that all its audio cables are unplugged and a single known good sound source is patched across the channels to test for correct operation by monitoring the output through headphones. This often eliminates problems with system earthing and matching with external equipment.

Faults may be of a permanent or intermittent nature. If intermittent try to induce the symptom by flexing cables, wiggling connectors, selective mechanical vibration or flexure, and thermal (hot, cold) cycling. Use substitution of known good components to aid identification of the faulty part.

## SERVICE PROCEDURES AND PRECAUTIONS.

---

Service work is best carried out with the unit on a clean work surface suitably covered to protect the *GRI* cosmetics. If a PCB component is suspected as faulty, the easiest way to replace it is to first cut all of the component legs and remove the component body. Then remove each leg individually with a small tip soldering iron and small pliers or tweezers. Use a solder sucker to clear the PCB holes. To remove the PCB follow the procedure: **REMOVING THE PCB.**

Before carrying out any service work observe the following precautions:

- Handle the unit and its internal assemblies with care to avoid damage to the components or cosmetics.
- Do not plug or unplug the internal IDC connectors or Option links with power applied.
- Check the connectors for correct alignment and seating.
- Use a good small tip soldering iron for circuit board work to avoid track or pad damage.

## REMOVING THE PCB

If it is necessary to replace a component on the main PCB, access to the underside of the PCB will be necessary to effect good solder joints. To remove the PCB, proceed as follows:

1. **Disconnect the AC mains input before disassembling the unit.**
2. Remove the six screws from the top cover and place it to one side.
3. Pull off the front panel knobs. The square switch caps can be left fitted.
4. Using suitable tools, remove the hex nuts retaining the rotary controls and PHONES jack socket.
5. Select the AUX position on all six of the SOURCE switches and remove the four front panel screws. The front panel can now be pulled forward but be careful not to stretch the power ON switch wires as these are still connected.
6. Working from the rear panel, remove the nine XLR fixing screws and the six D type connector fixings.
7. Then remove the two screws fixing the heatsink to the chassis from the underside of the unit.
8. Working from the front of the unit, the PCB can now be removed by first carefully lifting the right hand side just above the right chassis flange and then moving the PCB slightly to the right to clear the left hand chassis flange. **Note that the transformer wires are still connected to the PCB so any work to be carried out on the underside of the PCB must be done by rotating the PCB to the right.**

When all service work is complete, remove all debris such as solder, component legs and wire clippings from inside the unit, and check your work carefully before reassembly. To reassemble the unit follow the above procedure in reverse order. Check the *GRI* unit for correct mains voltage connection before switching on. Test for correct operation.

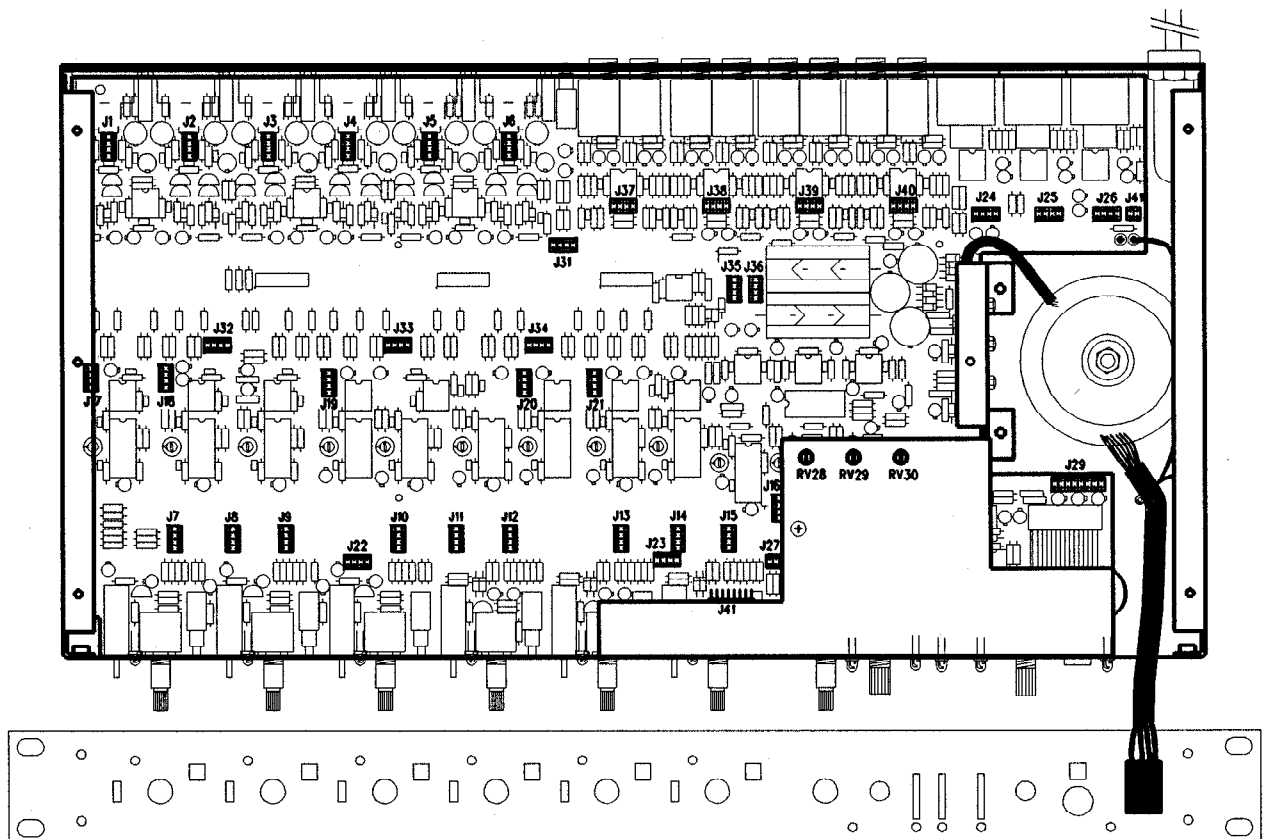

GR1 INTERNAL ASSEMBLY (FRONT PANEL REMOVED)

## VCA Calibration

The distortion calibration of the VCAs are factory set and do not normally require any adjustment during normal operation. In the unlikely event that a VCA should require replacement, then the distortion must be trimmed. The *GR1* has 12 VCA Integrated circuit devices (SSM2018); one in each mono input, two in each stereo input and one in each main output. The presets RV16 to RV27 are miniature horizontal types running from left to right along the centre of the main PCB.

To calibrate each input channel VCA:

1. **Warning AC mains voltage is present in the *GR1*. Use the correct tool when trimming the VCA presets and always remove power when setting the link options.**
2. Check the MIC input pad links are not fitted and the DIRECT OUT link is set to POST. Set the channel ROUTING links to the OUT position.
3. Connect an Audio Distortion meter to the direct out pin on the SYS-LINK OUT connector on the rear panel
4. Connect a balanced 0dBu low distortion 1kHz sine wave signal to the MIC IN XLR of the Channel.
5. Adjust the VCA preset until minimum harmonic distortion is obtained (typically 0.04%).

To calibrate a main output VCA:

1. **Warning AC mains voltage is present in the *GR1*. Use the correct tool when trimming the VCA presets and always remove power when setting the link options.**
2. Check the MIC input pad links are not fitted and that the ROUTING links on all channels are set to the IN position. Make sure the input channel VCAs have been trimmed first.
3. Connect an Audio Distortion meter to the main output XLR.
4. Connect a balanced 0dBu low distortion 1kHz sine wave signal to the MIC IN XLR of any channel.
5. Adjust the VCA preset until minimum harmonic distortion is obtained (typically 0.04%).

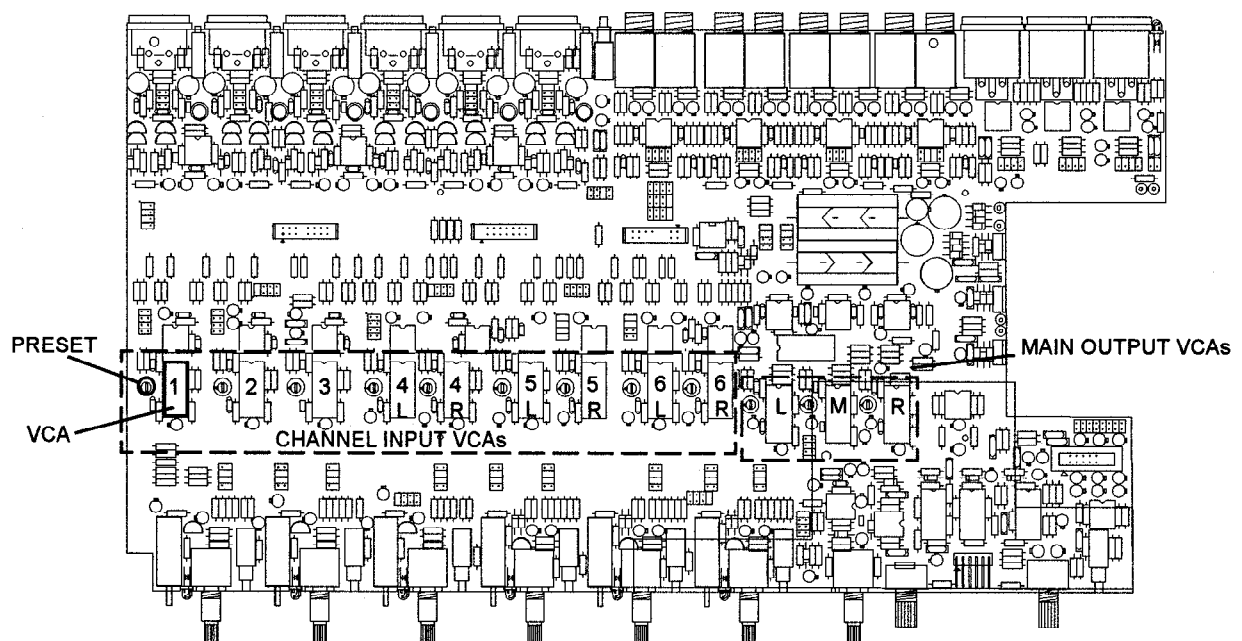

LOCATION OF VCAs & PRESETS



# ORDERING SPARE PARTS

## MANUALS AND SUPPORT DOCUMENTATION

DESCRIPTION	ORDER CODE
<i>GRI</i> User Guide	AP2057
<i>GRI</i> Service Manual	AP2059

## SERVICE TOOLS

The tools required to service the *GRI* are standard to an electronics service workshop and are easily obtainable. The following items are necessary for disassembly and service access:

1-point Crosshead screwdriver (M3, 4AB)	AT0004
15mm Nutdriver (jack nuts, potentiometer nuts)	

## ORDERING A SPARES KIT

It is recommended that the spares kit order code 002-009 is held and maintained by the service agent to enable in-field service repairs to the *GRI* independent of the ALLEN & HEATH factory. Commonly available items such as resistors, capacitors, tools and soldering equipment are not included. The contents of these kits is listed here. Individual spare parts may be ordered. Please quote the description and order code for the part required.

DESCRIPTION	ORDER CODE	QTY
-------------	------------	-----

### Fixings:

Screw 4AB x 5/16" Pan Pozi Black	AB0057	10
Screw M3 x 6mm Pan Pozi Black	AB0072	5
Screw M3 x 6mm CSK Pozi Black	AB0215	5
Screw M3 x 8mm Pan Pozi Black	AB0073	10
Screw M3 x 8mm CSK Pozi Black	AB0074	5
Nylock Nut M3	AB0102	5
Washer M3 101-653 Shake Proof	AB0244	2
Fixing for D type connector	AB2189	10

### Knobs and caps:

Knob Base 15mm grey P138-27	AJ2056	10
Knob Green & Grey 11mm	AJ2137	5
Knob Blue & Grey 11mm	AJ2136	5
Knob Brown & Grey 11mm	AJ2140	5
Knob Red & Grey 11mm	AJ2135	5
Button 5mm Square Grey	AJ2052	10

### Potentiometers, switches, and connectors:

10KBcc+100KA CHANNEL LEV & PAN	AI0058	2
100KA+100KA L/R OUTPUT LEV	AI0056	2
100KA x 2 HEADPHONE LEV	AI0055	2
100KA MONO OUTPUT LEV	AI0054	2
10K Preset 20turn MIC TRIM	AC0344	2
500K Preset VCA TRIM	AC0362	2
Pot Nut 11mm	AB0347	10
Pot Nut 9mm	NB0153	5
Switch Miniature 2PCO Latching	AL8065	3
Switch Lever 3 way	AL2049	2
Jack Socket Small	AL2048	3
Jack Socket Headphone	AL0328	2
XLR 3 Pin Female 90Deg PCB Mount	AL2053	3
XLR 3 Pin Male 90Deg PCB Mount	AL0576	2

**LEDs and Semiconductors:**

LED 3mm T1 Green	AE0085	2
LED 3mm T1 Red	AE0086	2
LED Rectangular Green LT2	AE0348	5
LED Rectangular Red LT2	AE0350	2
Transistor 2SB737 PNP	AE8069	5
Transistor BC549 NPN	AE0020	5
Transistor BC214C PNP	AE0031	5
IC NE5532N Dual Op Amp	AE0221	3
IC TL072CP Dual Op Amp	AE0046	3
IC LM339N Quad Comparator	AE0071	2
IC CMOS 4053B	AE0117	1
IC SSM2142P Bal Out Driver (AUX BAL OPT)	AE0302	3
IC SSM2018P VCA	AE0315	1
IC 4N35 Opto isolator	AE0266	1

**POWER SUPPLY:**

Mains Fuse 20mm 315mA (UK, EC)	AL0349	5
Mains Fuse 20mm 630mA (USA)	AL0297	5
Transformer 30VA Toroidal	AM0918	-
IC Regulator 7815 (+16V DC)	AE0047	2
IC Regulator 7195 (-16V DC)	AE0048	2
IC Adjustable Regulator 783 (+48V DC)	AE0214	2
Fuseholder 20mm Panel Mount	AL0578	1
Insulation Kit T0220 Silicon Impreg.	AA0693	5

**MISCELLANEOUS:**

GR1 Packing assembly	002-008	-
Heatshrink sleeve 5cm	AH2223	-
Jumper socket 2way	AL0334	20
Ferrite Bead Axial	AF0610	5

# **SECTION C**



## **TECHNICAL DIAGRAMS**

**This section includes the technical diagrams  
and illustrations**

# TECHNICAL BULLETIN

## Attention Service Departments

REF.	GR1_01	Issue No.	1	Date:	25-11-94	Page:	1 of: 1
Title:	ISSUE 3 PCB MODIFICATIONS			Authorised:	I Mc B		

File with GR1 Service Manual

The following applies to all GR1 units with Issue 3 PCBs (AG2041 Issue 3).

## 1) GR1 PCB Issue 3

The issue 3 version of the GR1 PCB (AG2041 Issue 3) has a number of minor modifications. These are:

- i: SYS-LINK OUT L and M are swapped. This is corrected by crossing over two resistors R643 and R645.
- ii: The meter PCB is too far back from the front panel. This is corrected by spacing the PCB 1.6mm forward on the connector pins.
- iii: The MONO and PHONES level controls are too far back from the front panel. This is corrected by placing washers over the control shafts.
- iv: The text legend on link J22 is in the wrong position. The text should be moved one position to the right.

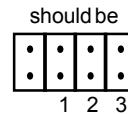
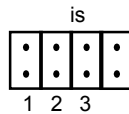

All of these errors have been corrected for the issue 4 version of the PCB.

# Front Panel Assembly

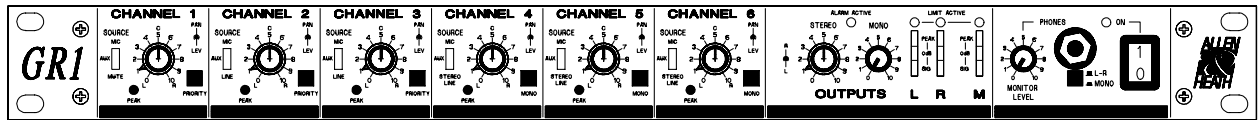

# Rear Panel Assembly

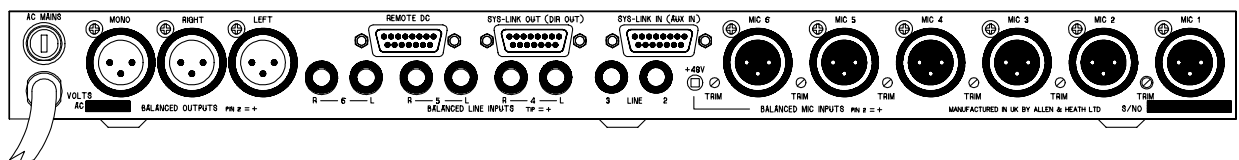

THIS APPARATUS MUST BE EARTHED



DISCONNECT FROM MAINS SUPPLY BEFORE REMOVING COVER

SEE REAR FOR VOLTAGE SETTING

REPLACE FUSE WITH CORRECT TYPE FOR MAINS SUPPLY

FUSE TYPE	AC MAINS SUPPLY
T 315 mA	220-240V~
T 630 mA	100-120V~

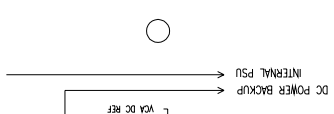
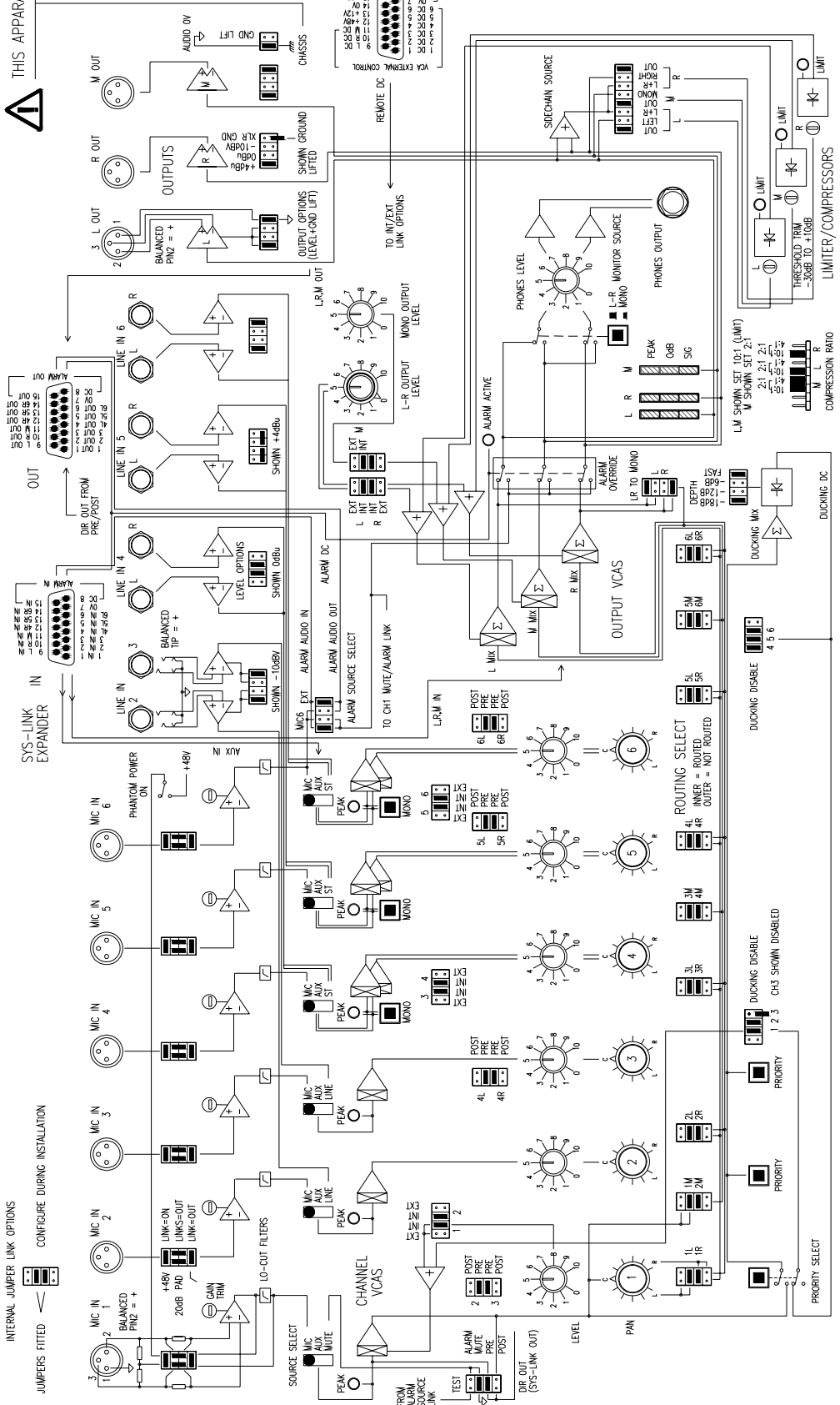

GR1

INTERNAL JUMPER LINK OPTIONS  
CONFIGURE DURING INSTALLATION

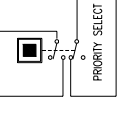
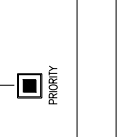
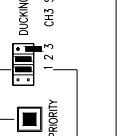
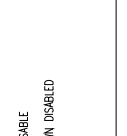
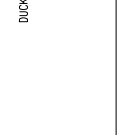
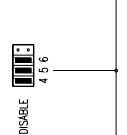
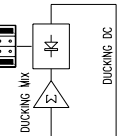
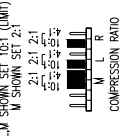
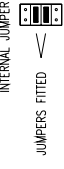

# Internal Assembly

Front panel, knobs and switch caps removed.

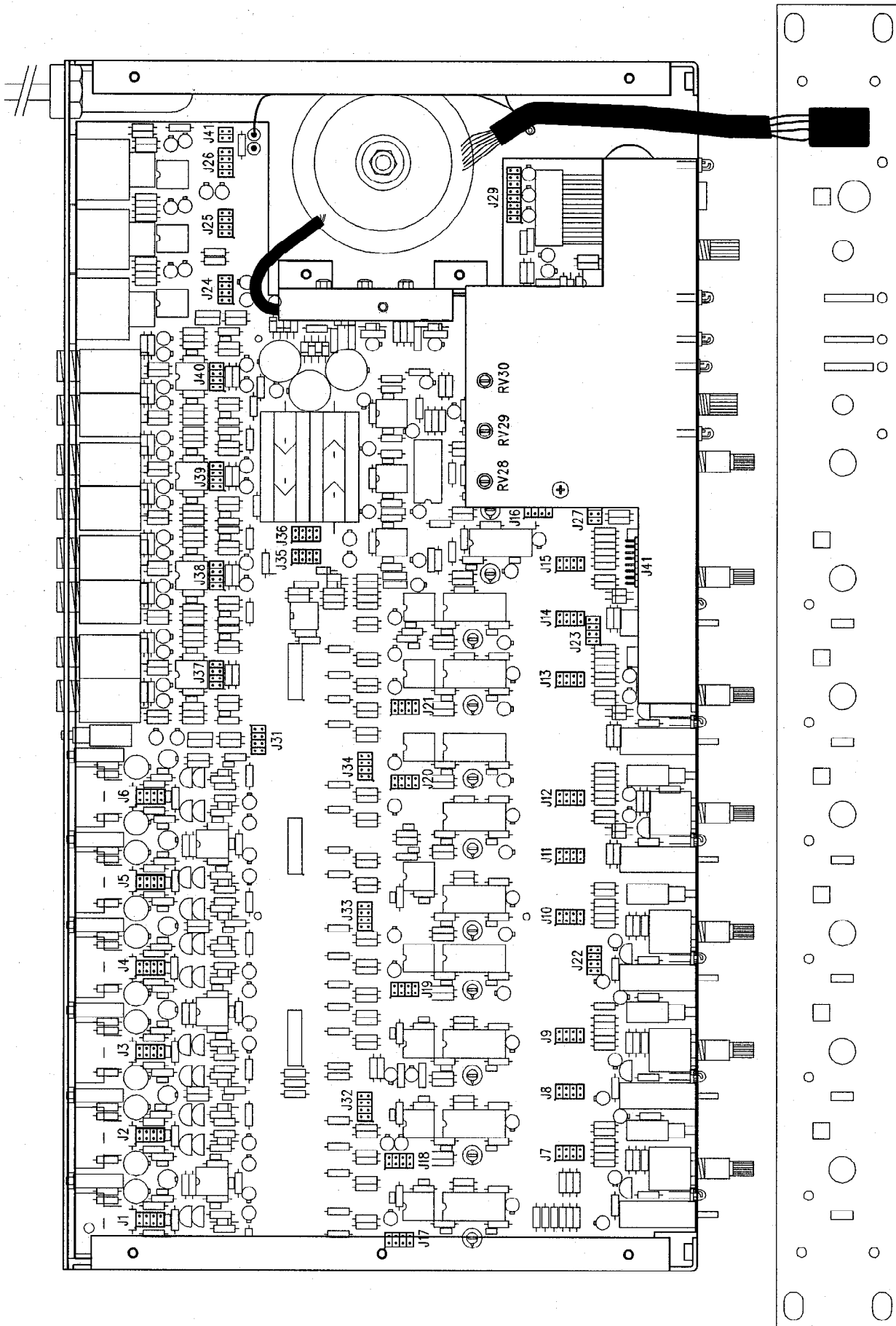

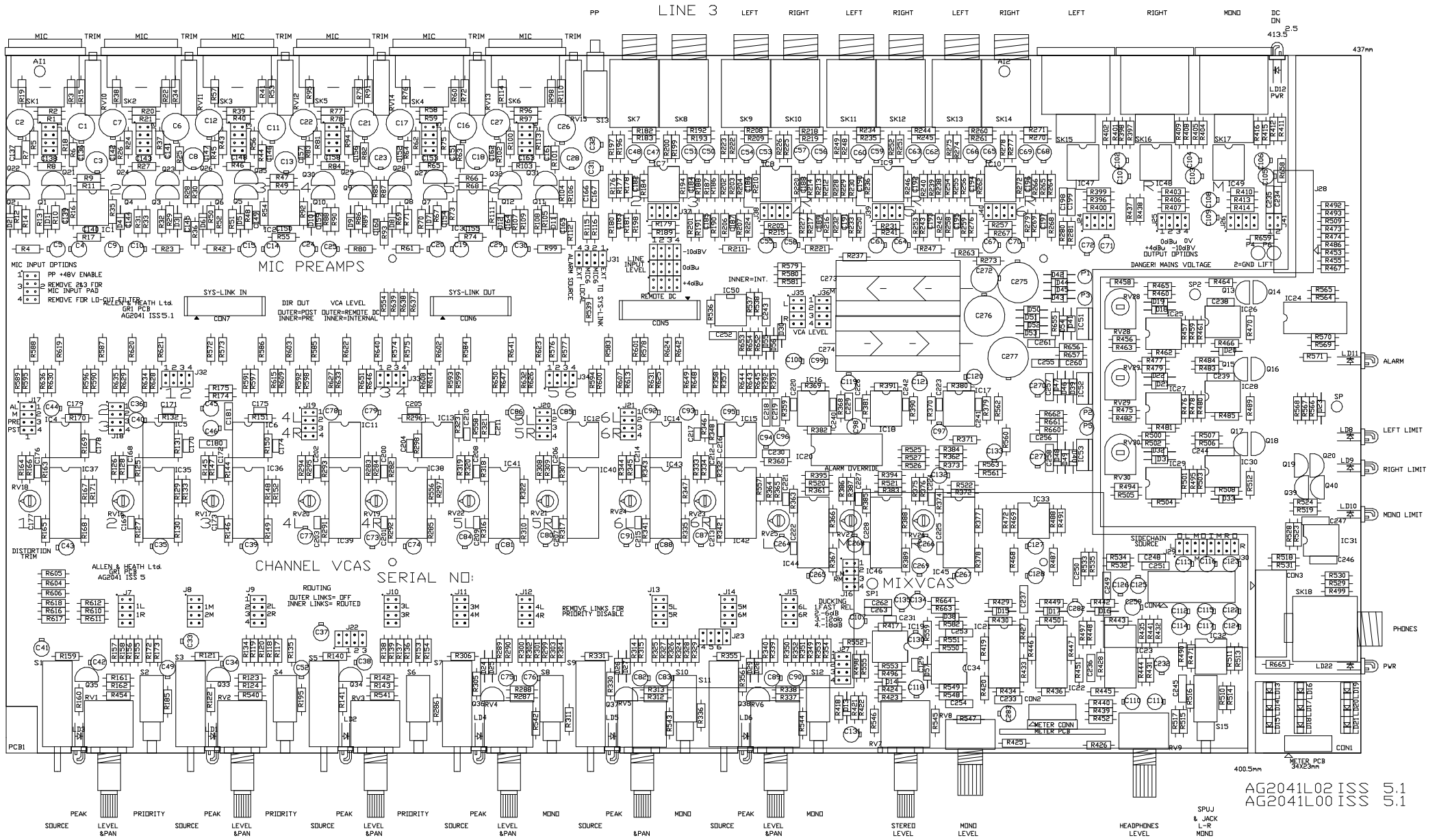

AG2041L02 ISS 5.1  
 AG2041L00 ISS 5.1



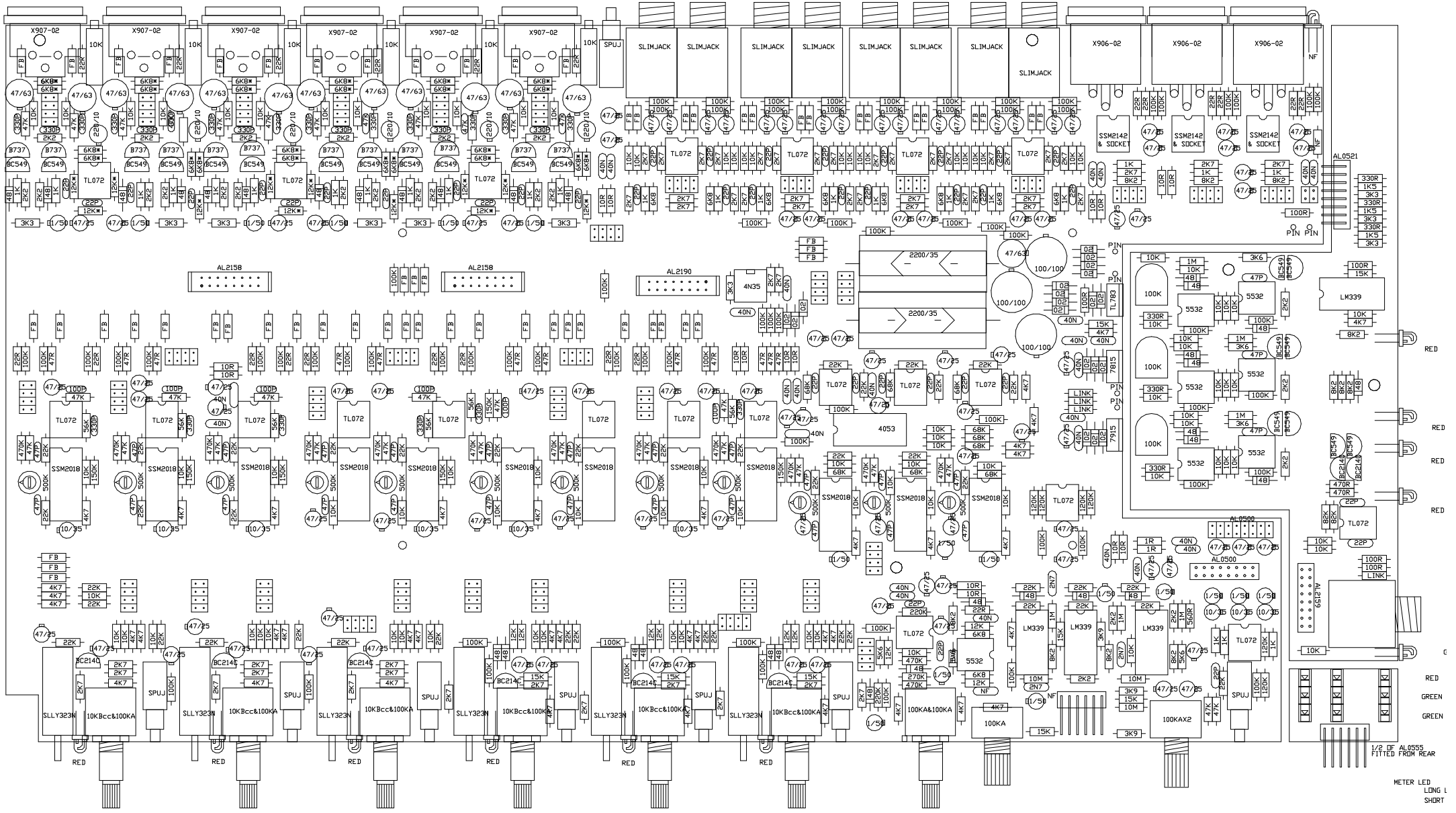

1/2 OF AL0555 FITTED FROM REAR  
METER LED  
LING L  
SHORT

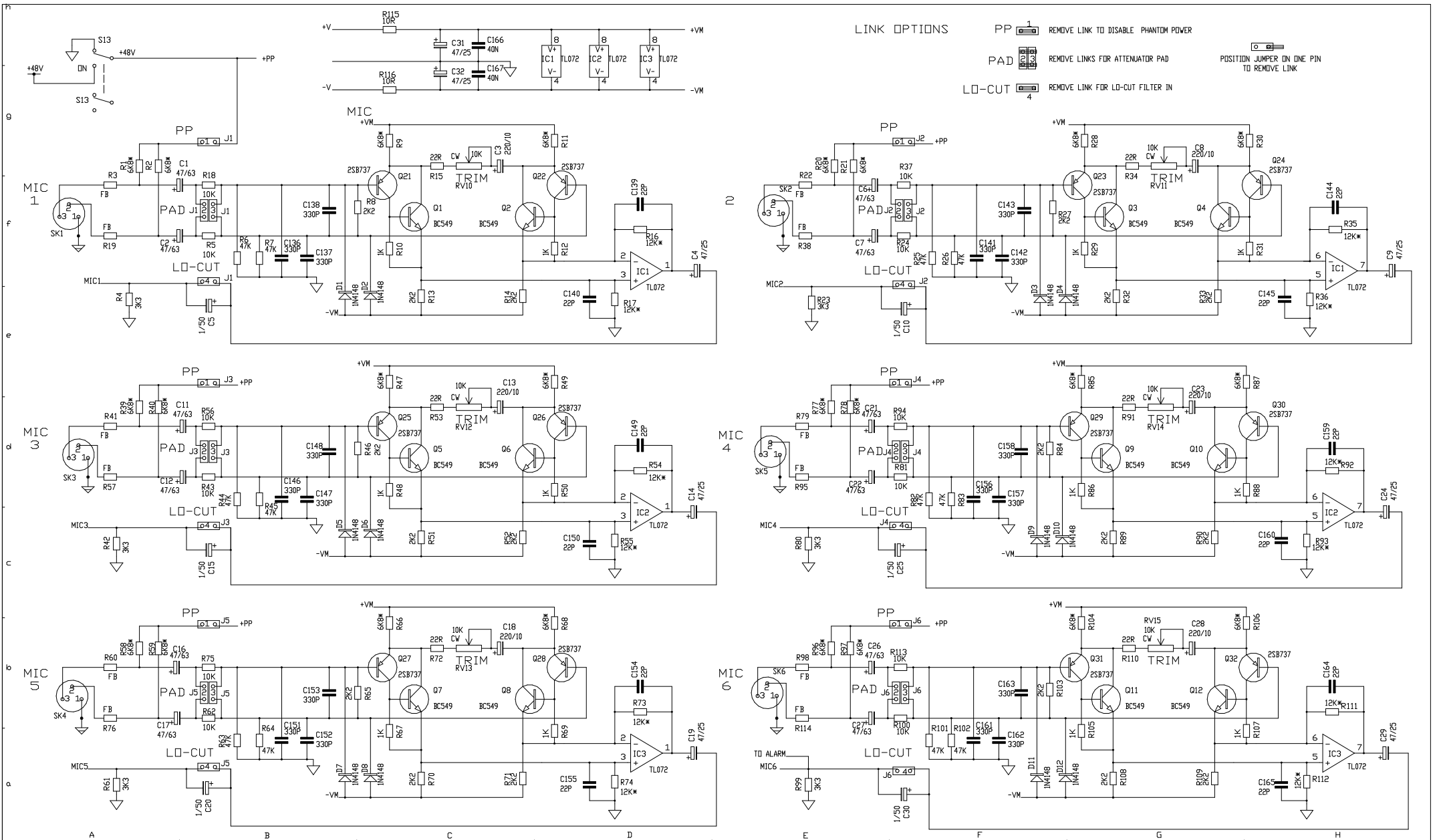

LINK OPTIONS

PP  REMOVE LINK TO DISABLE PHANTOM POWER

PAD  REMOVE LINKS FOR ATTENUATOR PAD

POSITION JUMPER ON ONE PIN TO REMOVE LINK

LO-CUT  REMOVE LINK FOR LO-CUT FILTER IN

ISS.	REVISION	BY	DATE
A	ORIGIN	JMCB	17/3/94
1	REVISED DRAWN	JMCB/CD	1-8-94
2	MODIFIED FOR ISSUE 3 PCB	JMCB	30/9/94
3	REVISION	JWD	3-11-99

- NOTES
1. RESISTORS MARKED \* ARE 1% ALL OTHERS ARE 5% 1/4W UNLESS OTHERWISE MARKED
  2. ELECTROLYTIC CAPACITORS ARE 50V/VOLTS

UNIT TITLE	GR1	SHEET	1 OF 11
DRAWING TITLE	CHANNEL MIC PREAMPS		

MANUFACTURED IN ENGLAND BY	ALLEN & HEATH
DRAWING No.	C2041
ISSUE	3
	A2

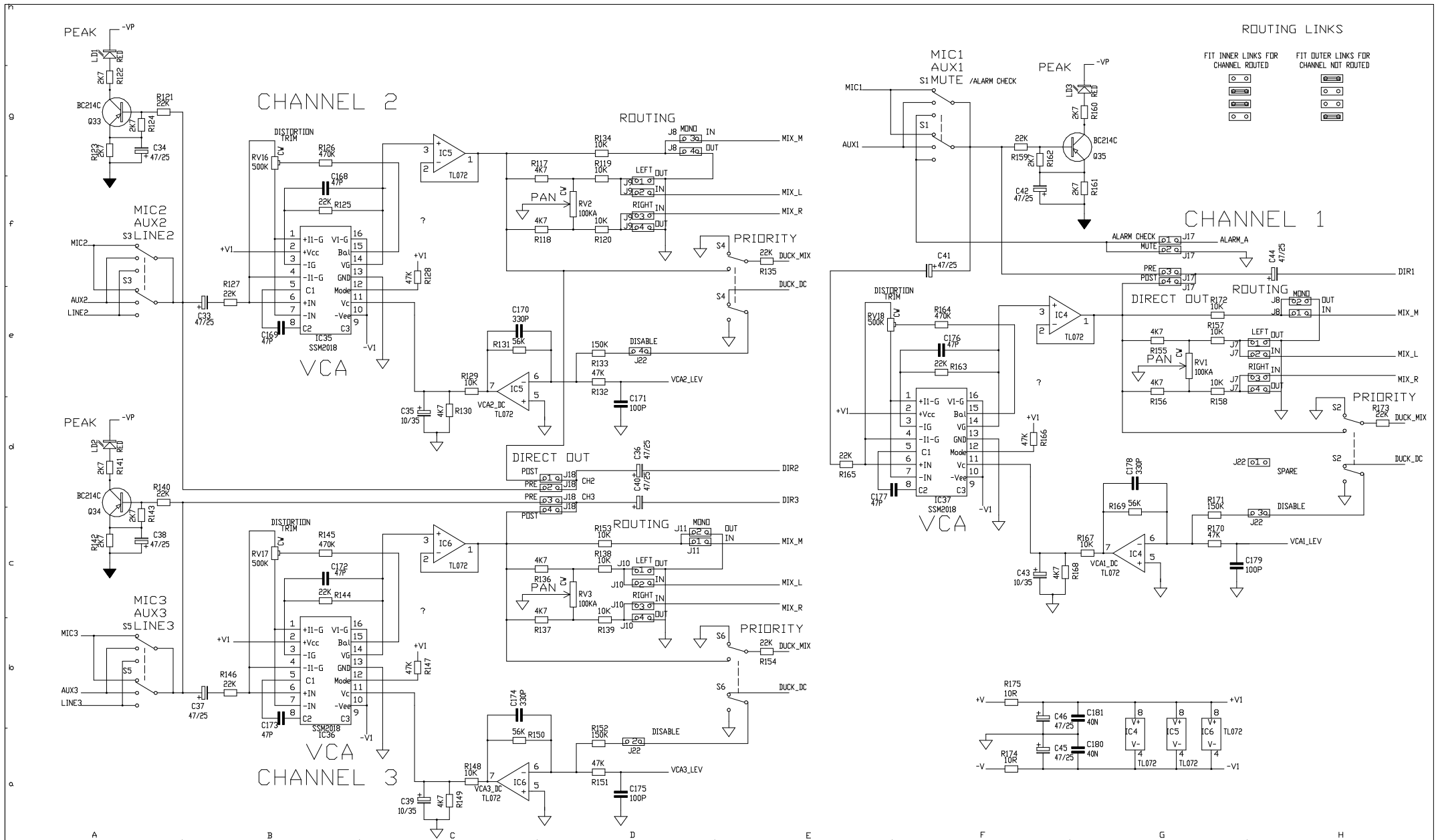

ISS.	REVISION	BY	DATE	NOTES	UNIT TITLE	SHEET	MANUFACTURED IN ENGLAND BY
A	ORIGIN	JMcB	17/3/94	1. RESISTORS MARKED * ARE 1% ALL OTHERS ARE SZ 1/4W UNLESS OTHERWISE MARKED	GR1	2 OF 11	ALLEN & HEATH
1	REVISED DRAWN	JMcB/CD	1-8-94		DRAWING TITLE		
2	MODIFIED FOR ISSUE 3 PCB	JMcB	30/9/94		MONO CHANNELS 1-3		
3	REVISION	JWD	3-11-99	2. ELECTROLYTIC CAPACITORS ARE 10V/50µF			DRAWING No. C2041 ISSUE 3 A2

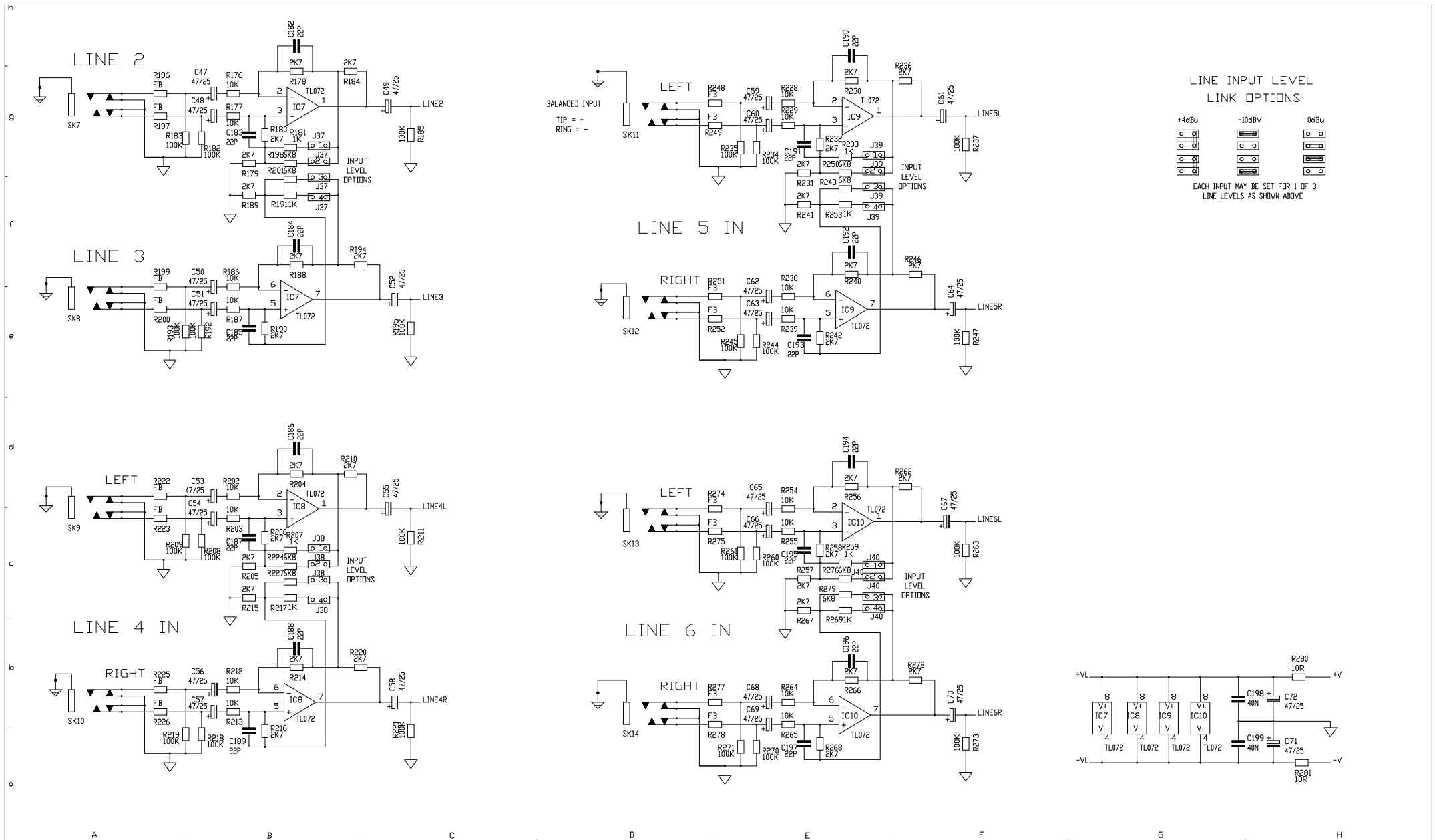

LINE INPUT LEVEL LINK OPTIONS

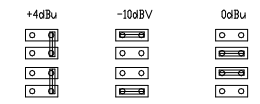

EACH INPUT MAY BE SET FOR 1 OF 3 LINE LEVELS AS SHOWN ABOVE

ISS.	REVISION	BY DATE	NOTES	UNIT TITLE	SHEET	MANUFACTURED IN ENGLAND BY
A	ORIGIN	JMcB 17/3/94	1. RESISTORS MARKED * ARE 1% ALL OTHERS ARE SZ 1/4W UNLESS OTHERWISE MARKED	GR1	3 OF 11	ALLEN & HEATH
1	REVISED/DRAWN	JMcB/CD 1-8-94		DRAWING TITLE		
2	MODIFIED FOR ISSUE 3 PCB	JMcB 30/9/94	2. ELECTROLYTIC CAPACITORS ARE 1% VOLTAGE	CHANNEL LINE INPUTS		DRAWING No. C2041 ISSUE 3
3	REVISION	JWD 3-11-99				A2

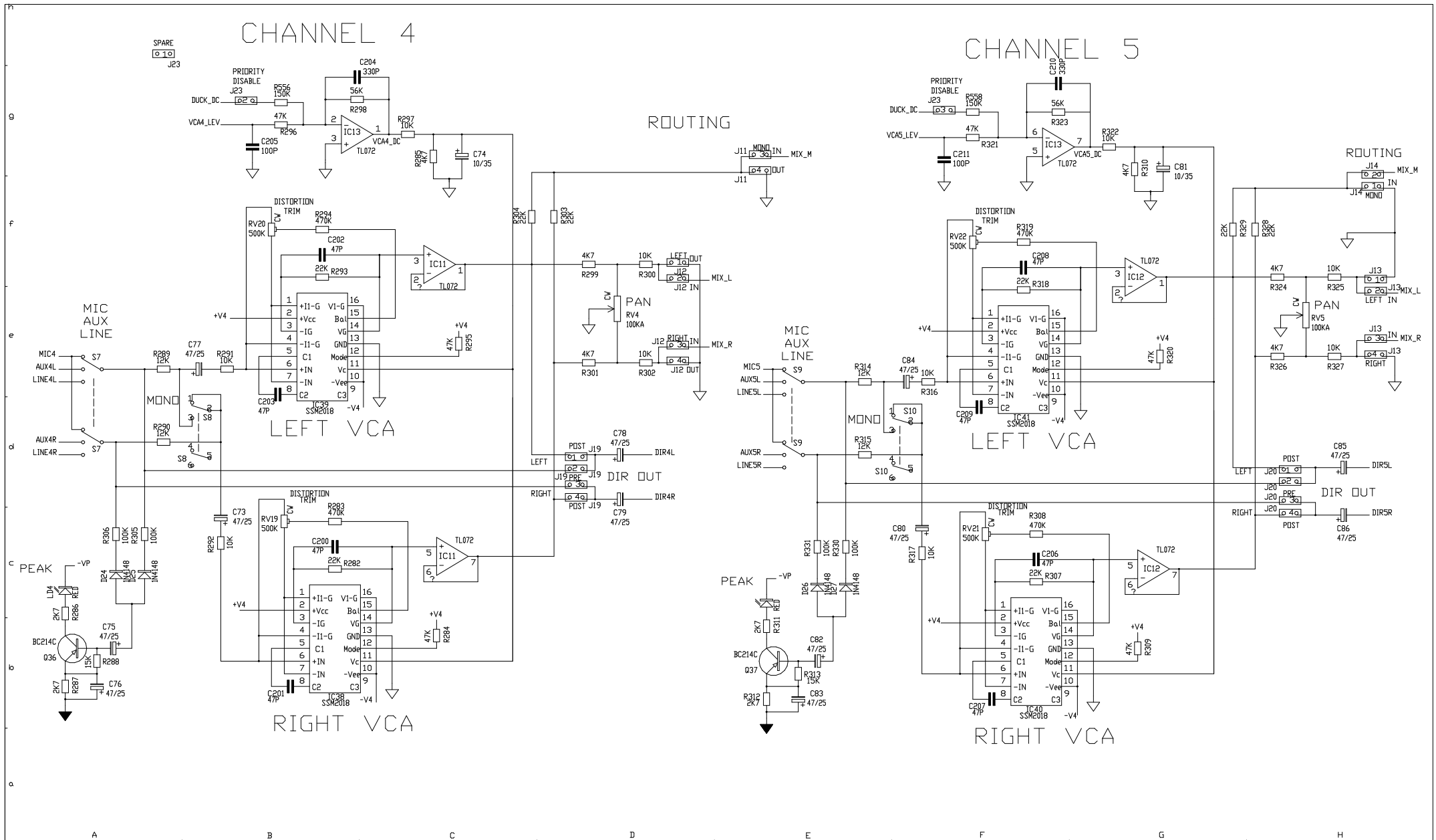

ISS.	REVISION	BY	DATE	NOTES	UNIT TITLE	SHEET	MANUFACTURED IN ENGLAND BY
A	ORIGIN	JMCB	17/3/94	1. RESISTORS MARKED * ARE 1% ALL OTHERS ARE SZ 1/4W UNLESS OTHERWISE MARKED	GR1	4 OF 11	ALLEN & HEATH
1	REVISED DRAWN	JMCB/CD	1-8-94	2. ELECTROLYTIC CAPACITORS ARE $\mu$ F/VOLTS	DRAWING TITLE		
2	MODIFIED FOR ISSUE 3 PCB	JMCB	30/9/94		STEREO CHANNELS 4 & 5		
3	REVISION	JWD	3-11-99				DRAWING No. C2041 ISSUE 3 A2

# CHANNEL 6

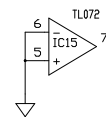
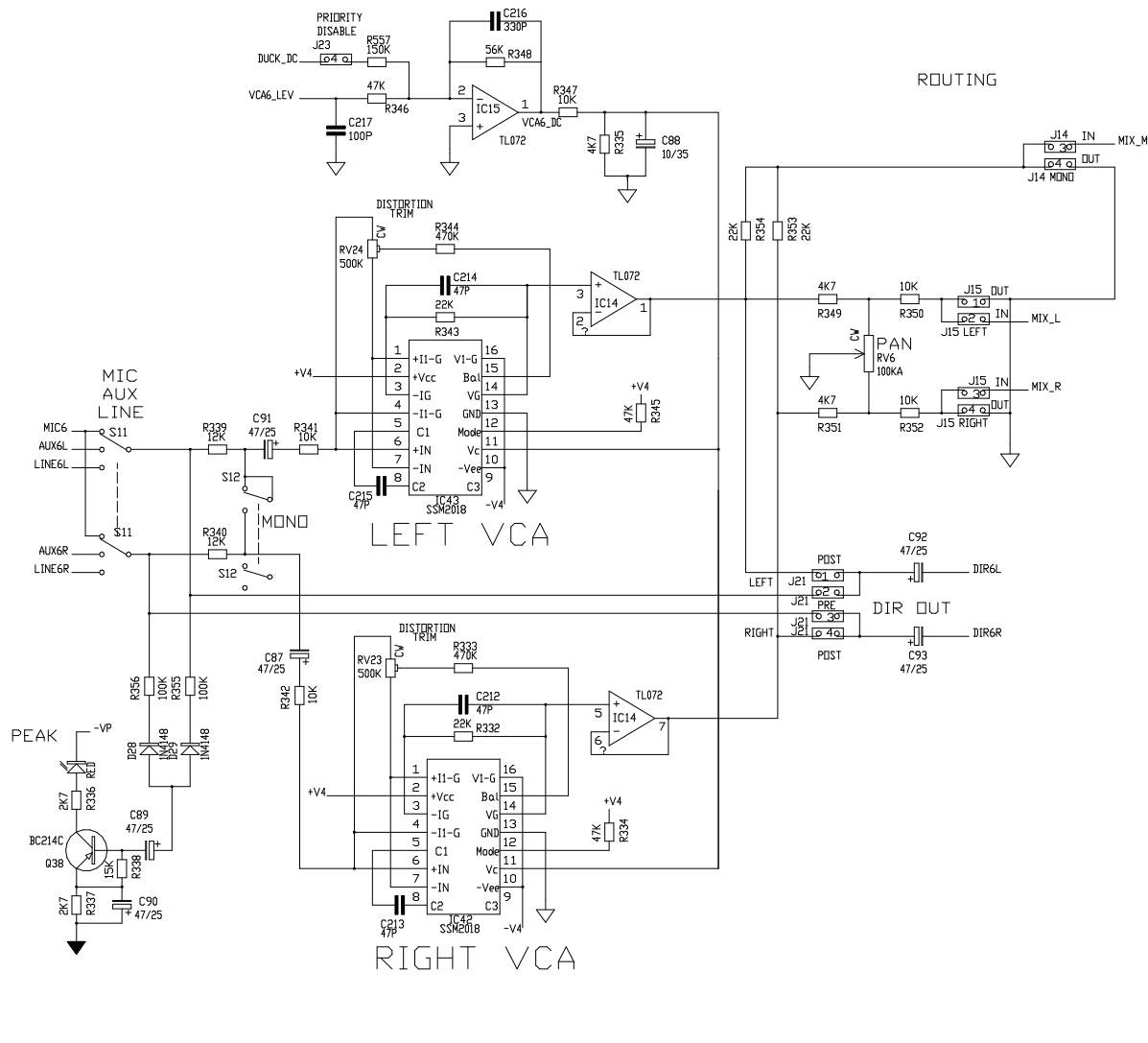

## ROUTING LINKS

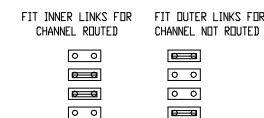

## PRIORITY DISABLE

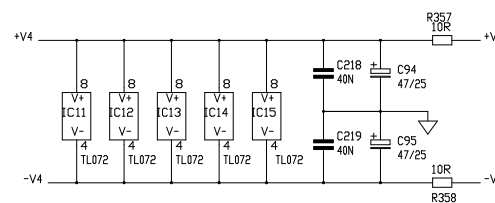
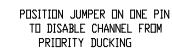

ISS.	REVISION	BY DATE	NOTES	UNIT TITLE	SHEET	MANUFACTURED IN ENGLAND BY
A	ORIGIN	JMcB 17/3/94	1. RESISTORS MARKED * ARE 1% ALL OTHERS ARE SZ 1/4W UNLESS OTHERWISE MARKED	GR1	5 OF 11	ALLEN & HEATH
1	REVISED DRAWN	JMcB/CD 1-8-94		DRAWING TITLE		
2	MODIFIED FOR ISSUE 3 PCB	JMcB 30/9/94	2. ELECTROLYTIC CAPACITORS ARE 1% VOLTAGE	STEREO VCA CHANNEL 6		DRAWING No. C2041 ISSUE 3
3	REVISION	JWD 3-11-99				A2

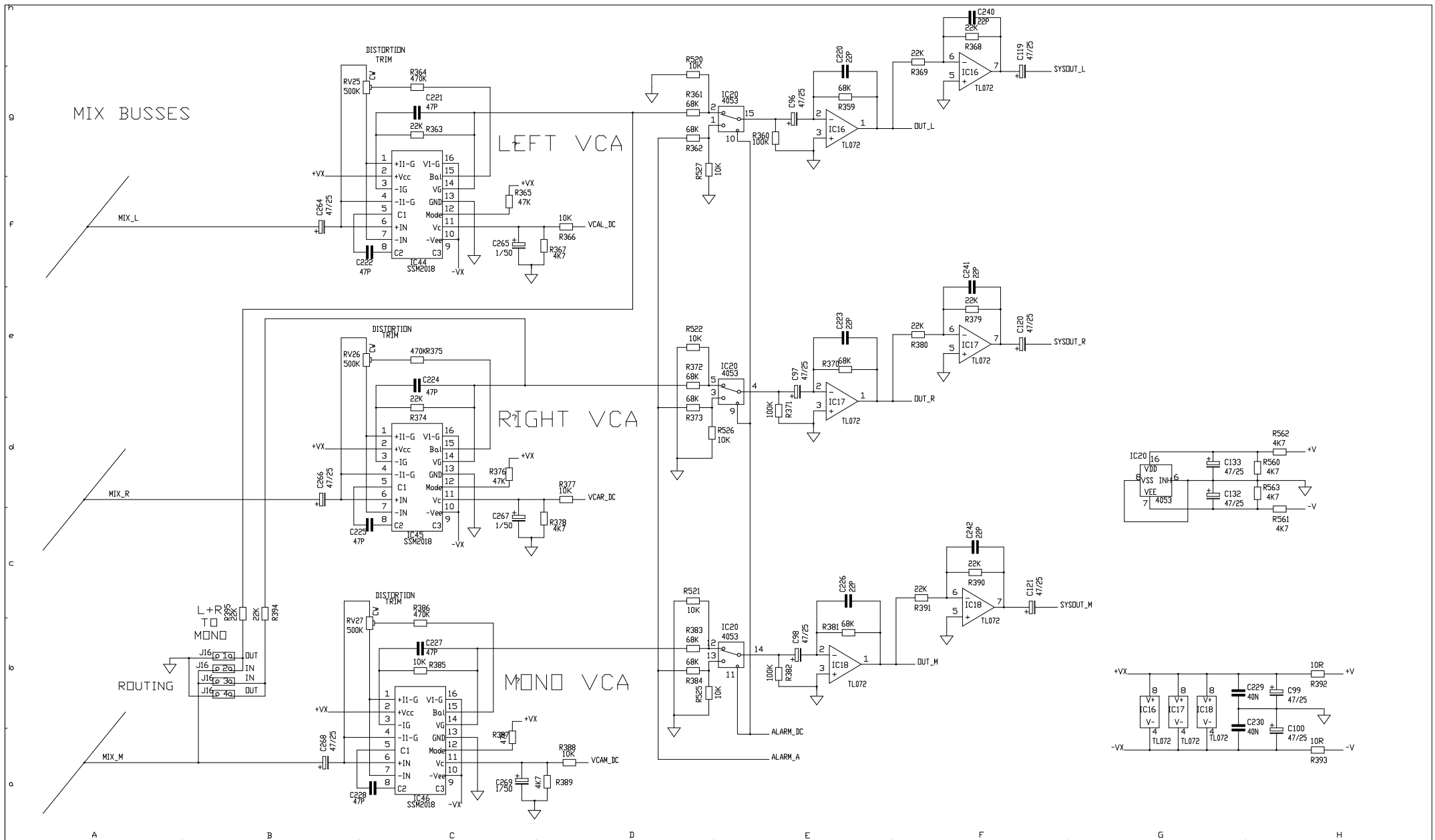

ISS.	REVISION	BY	DATE	NOTES	UNIT TITLE	SHEET	MANUFACTURED IN ENGLAND BY
A	ORIGIN	JMcB	17/3/94	1. RESISTORS MARKED * ARE 1% ALL OTHERS ARE 5% 1/4W UNLESS OTHERWISE MARKED	GR1	6 OF 11	ALLEN & HEATH
1	REVISED DRAWN	JMcB/CD	1-8-94	2. ELECTROLYTIC CAPACITORS ARE 10% VOLTAGE	DRAWING TITLE		
2	MODIFIED FOR ISSUE 3 PCB	JMcB	30/9/94		L, R & MONO MIX VCAS		
3	REVISION	JWD	3-11-99				DRAWING No. C2041 ISSUE 3 A2

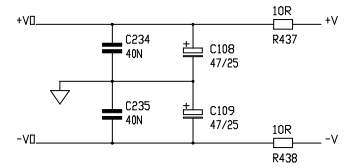
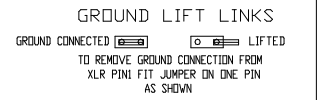
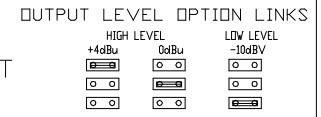
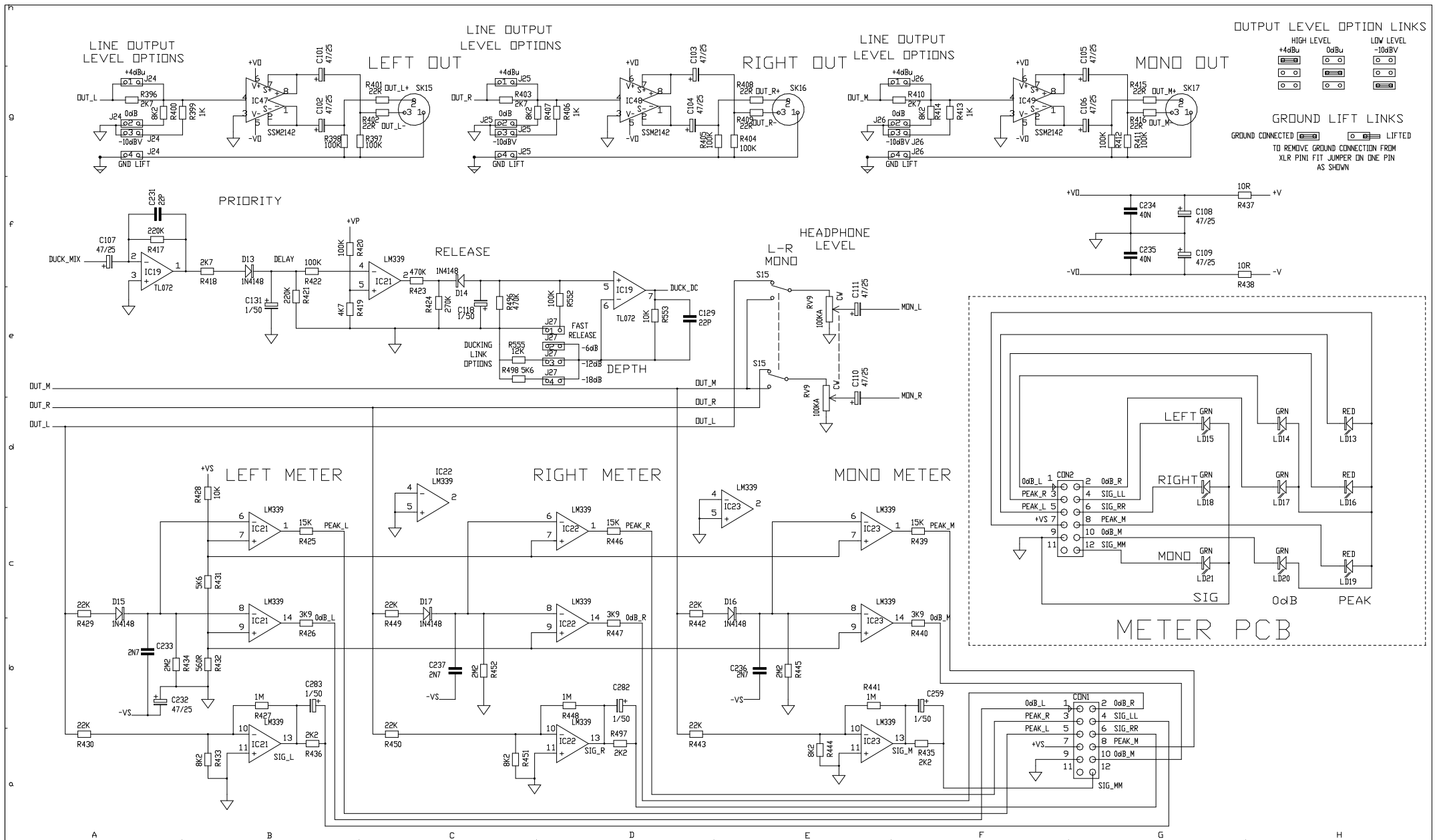

ISS.	REVISION	BY	DATE	NOTES	UNIT TITLE	SHEET	MANUFACTURED IN ENGLAND BY
A	ORIGIN	JMcB	17/3/94	1. RESISTORS MARKED * ARE 1% ALL OTHERS ARE 5% 1/4W UNLESS OTHERWISE MARKED	GR1	7 OF 11	ALLEN & HEATH
1	REVISED DRAWN	JMcB/CD	1-8-94		DRAWING TITLE		
2	MODIFIED FOR ISSUE 3 PCB	JMcB	30/9/94	2. ELECTROLYTIC CAPACITORS ARE 1% VOLTAGE	L, R & MONO OUTPUTS METERS & PRIORITY CIRCUIT		
3	REVISION	JWD	3-11-99				DRAWING No. C2041 ISSUE 3 A2



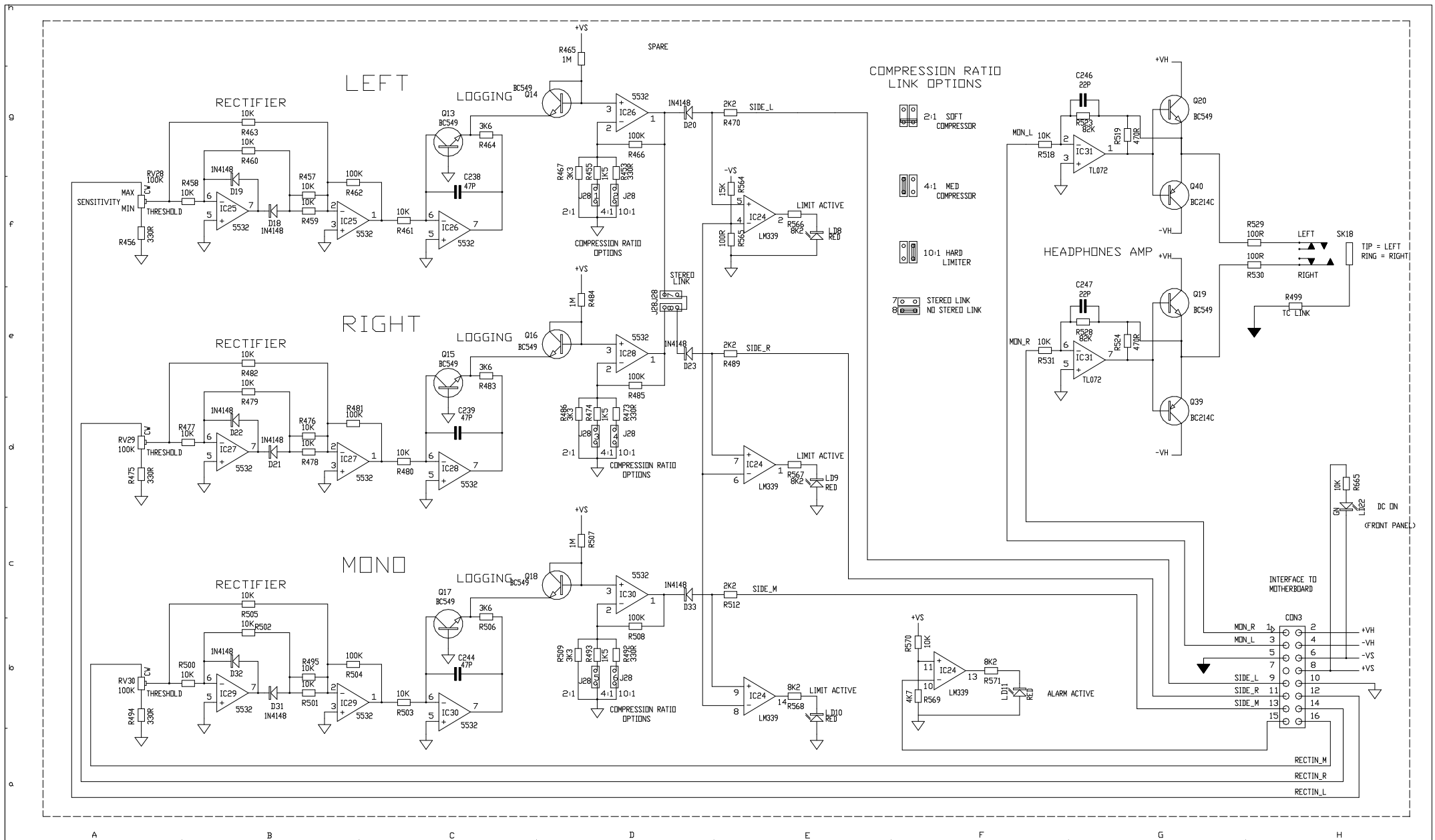

ISS.	REVISION	BY DATE	NOTES	UNIT TITLE	SHEET	MANUFACTURED IN ENGLAND BY
A	ORIGIN	JMcB 17/3/94	1. RESISTORS MARKED * ARE 1% ALL OTHERS ARE 5% 1/4W UNLESS OTHERWISE MARKED	GR1	8 OF 11	ALLEN & HEATH
1	REVISED DRAWN	JMcB/CD 1-8-94		DRAWING TITLE		
2	MODIFIED FOR ISSUE 3 PCB	JMcB 30/9/94	2. ELECTROLYTIC CAPACITORS ARE 1% VOLTAGE	COMPRESSOR DAUGHTERBOARD		DRAWING No. C2041
3	REVISION	JWD 3-11-99				ISSUE 3

A2

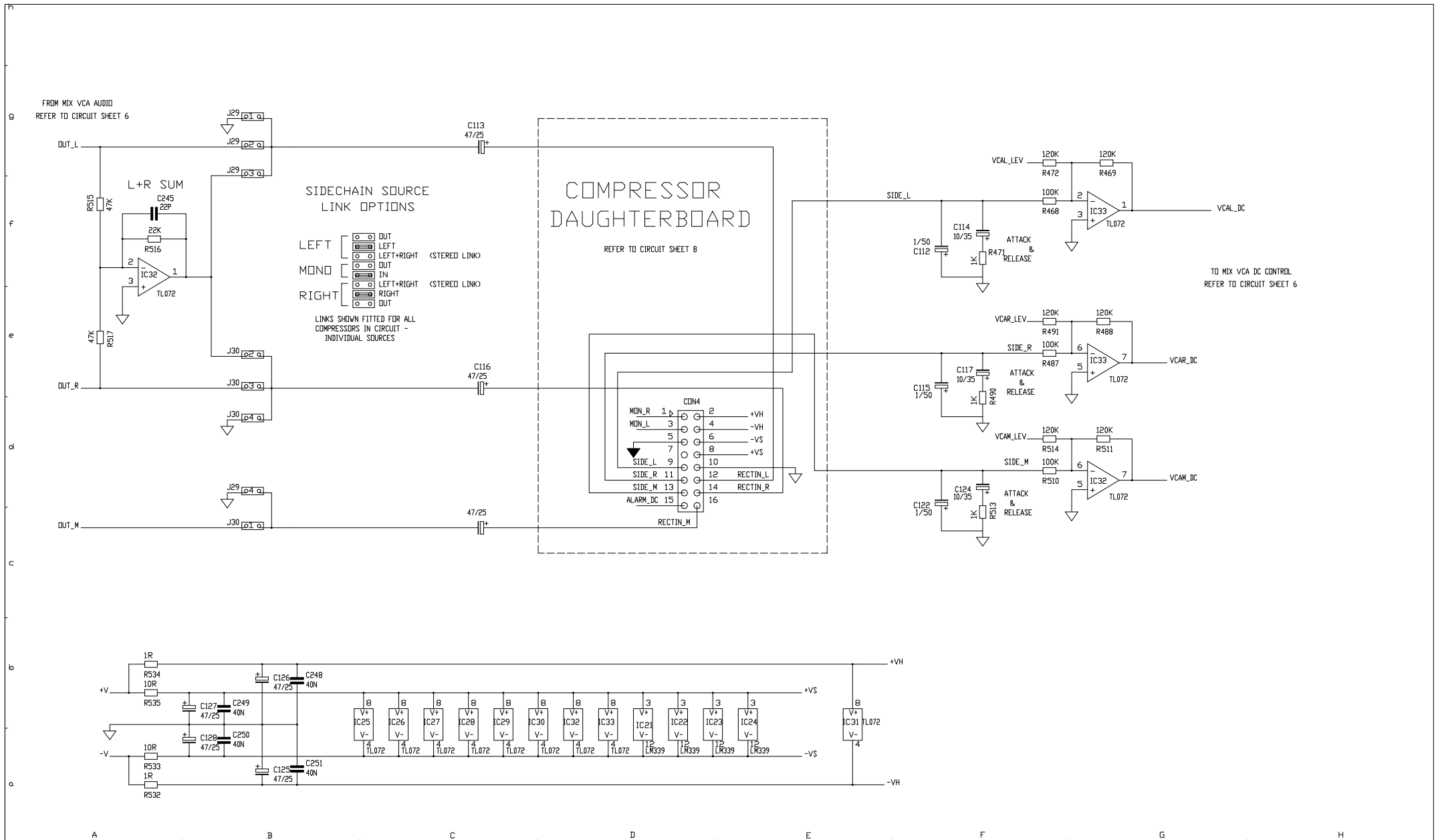

ISS.	REVISION	BY	DATE	NOTES	UNIT TITLE	SHEET	MANUFACTURED IN ENGLAND BY
A	ORIGIN	JMcB	17/3/94	1. RESISTORS MARKED * ARE 1% ALL OTHERS ARE 5% 1/4W UNLESS OTHERWISE MARKED	GR1	9 OF 11	ALLEN & HEATH
1	REVISED/DRAWN	JMcB/CD	1-8-94	2. ELECTROLYTIC CAPACITORS ARE 1% VOLTAGE	DRAWING TITLE		
2	MODIFIED FOR ISSUE 3 PCB	JMcB	30/9/94		COMPRESSOR SIDECHAIN INTERFACE		
3	REVISION	JWD	3-11-99		& SUPPLY DISTRIBUTION		DRAWING No. C2041 ISSUE 3 A2

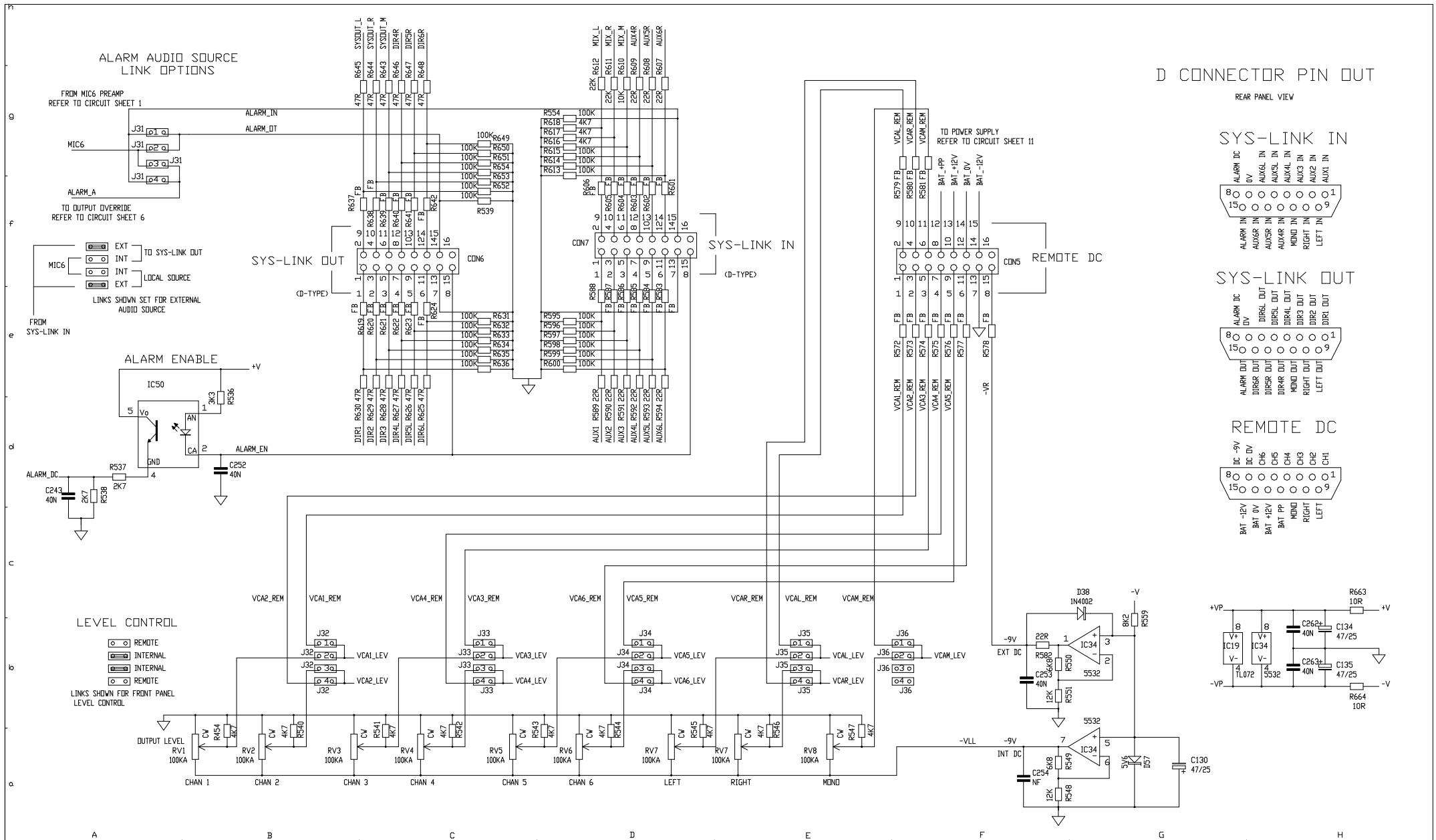

D CONNECTOR PIN OUT

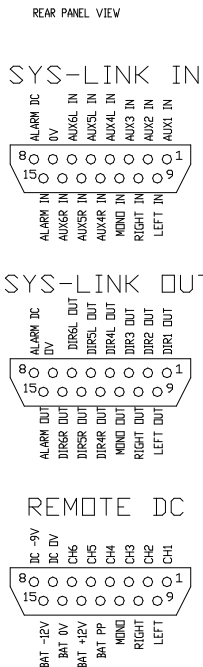

ISS.	REVISION	BY	DATE	NOTES	UNIT TITLE	SHEET	MANUFACTURED IN ENGLAND BY
A	ORIGIN	JMCB	17/3/94	1. RESISTORS MARKED * ARE 1% ALL OTHERS ARE SZ 1/4W UNLESS OTHERWISE MARKED	GR1	10 OF 11	ALLEN & HEATH
1	REVISED DRAWN	JMCB/CD	1-8-94		DRAWING TITLE		
2	MODIFIED FOR ISSUE 3 PCB	JMCB	30/9/94	2. ELECTROLYTIC CAPACITORS ARE 1%VOLT	LEVEL CONTROLS, SYS-LINK IN-OUT & REMOTE OPTIONS		
3	REVISION	JWD	3-11-99				DRAWING No. C2041 ISSUE 3 A2

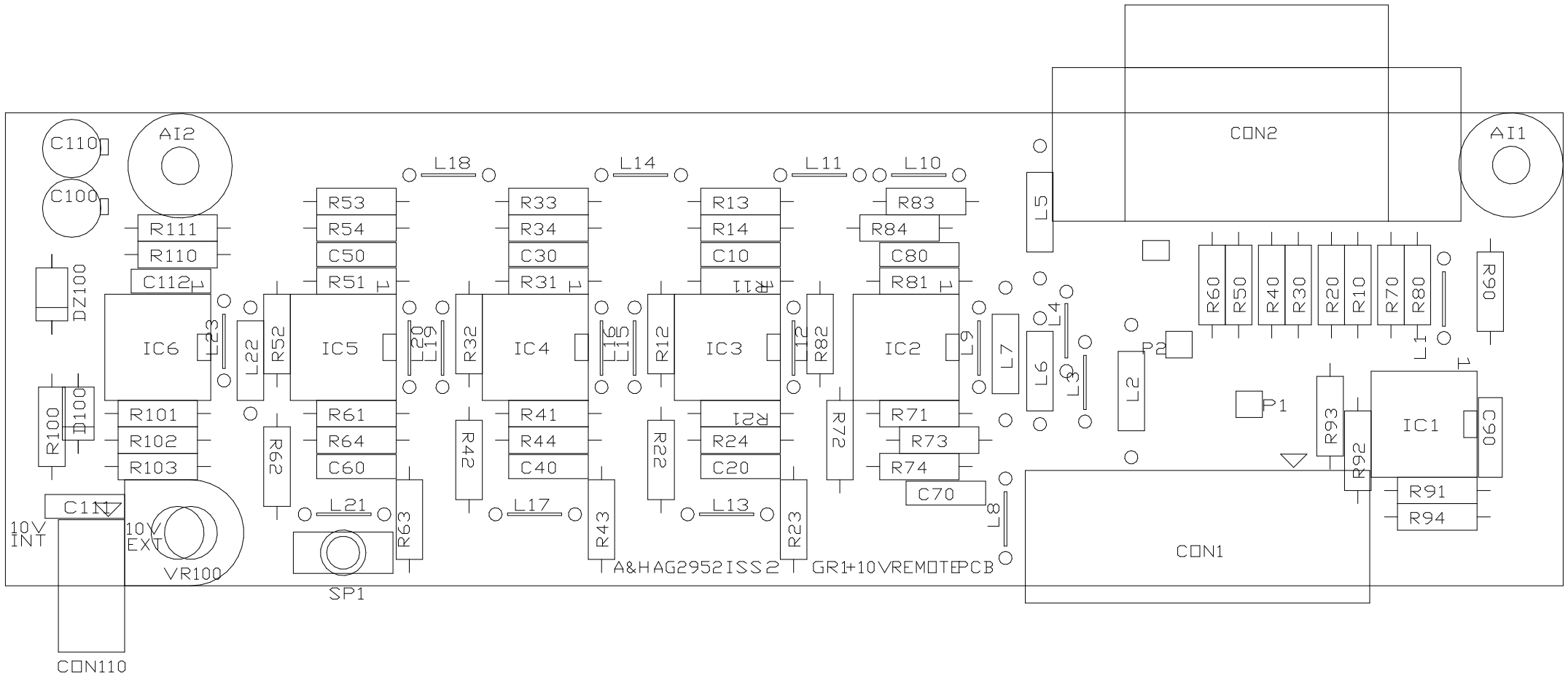

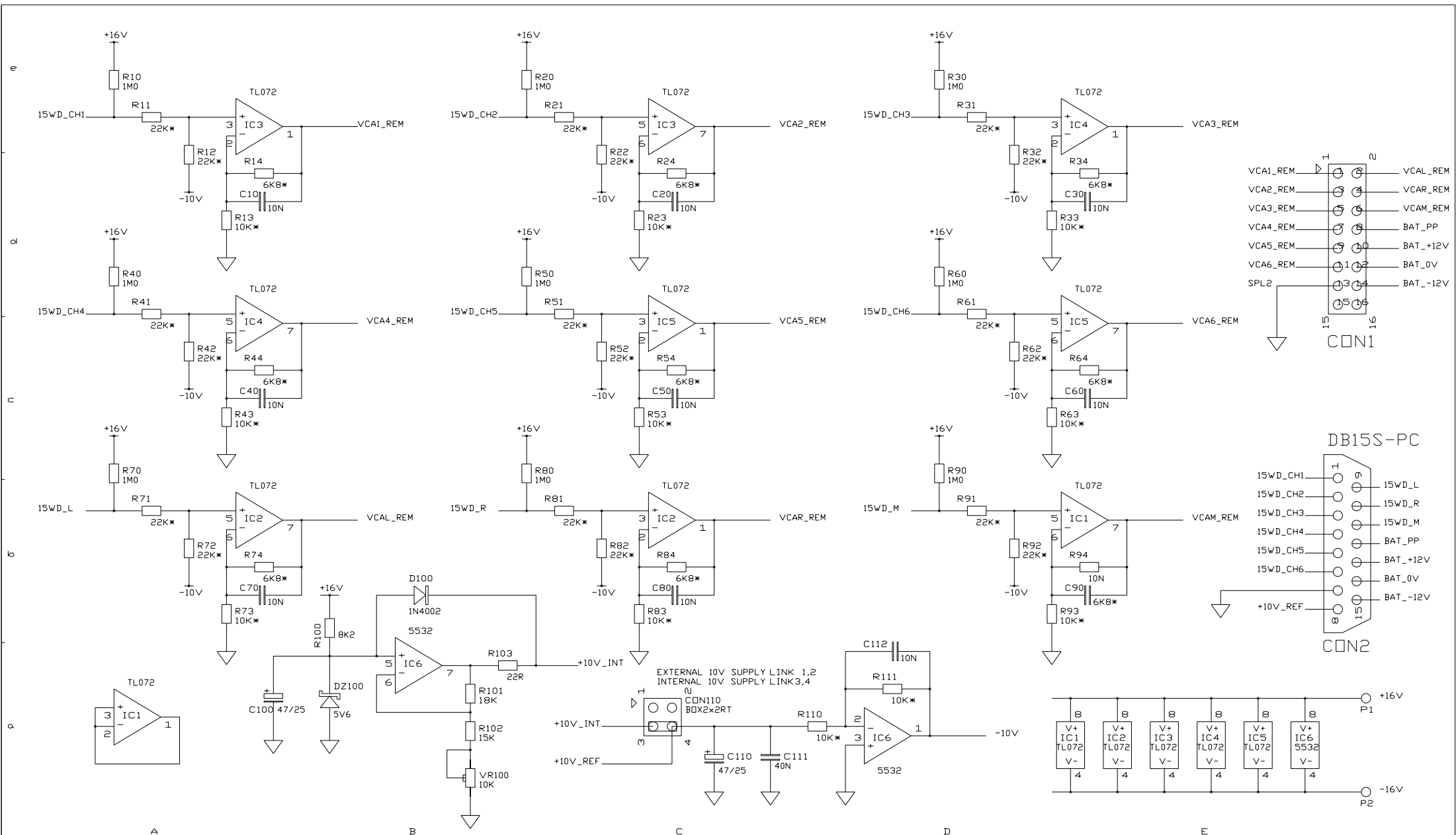

ISS.	REVISION	BY	DATE	NOTES	UNIT TITLE	MANUFACTURED IN ENGLAND BY
A	ORIGIN	AAT	13-02-97		GR1	ALLEN & HEATH
1	PRODUCTION	AAT	24-02-97	1. RESISTORS MARKED * ARE 1% ALL OTHERS ARE 5% 1/4W UNLESS OTHERWISE MARKED	PCB TYPE	
2	PCB UPDATE	AAT	27-04-99	2. ELECTROLYTIC CAPACITORS ARE ?F/VOLTS	AG2952	
2.1	R101 FROM 15K TO 18K	DWD	15-01-02			DRAWING No. C2952 ISSUE 2.1 A3