

# *GS1*

*compact 8 buss console*

**ALLEN  
&  
HEATH**

## **SERVICE MANUAL**

PUBLICATION AP2064

# INTRODUCTION

---

The information presented in this manual is intended for competent technical personnel to carry out service and product support for the **GS1**. We assume that the reader is familiar with the related electronic theory and audio terminology, and is able to carry out basic servicing, fault-finding and repair of audio equipment of this type. Service personnel should also be familiar with audio systems, mains earthing and power requirements, as well as handling precautions.

For further information on the operation and application of the **GS1**, please refer to the **USER GUIDE** publication AP2061 supplied with each unit.

Whilst we believe the information in this manual to be reliable we do not assume responsibility for inaccuracies. We also reserve the right to make changes in the interest of further product development.

# SERVICE AND TECHNICAL SUPPORT

---

Under normal conditions the **GS1** does not require user maintenance or internal calibration. Any service work required should be carried out by qualified technical personnel only.

We are able to offer further product support through our worldwide distribution network. To help us provide the most efficient service please would you quote the console serial number in any communication regarding this product.

## SAFETY WARNING !

Mains electricity is dangerous and can kill. Mains voltage is **not** present within the **GS1** console but **is present** in the external power supply unit. Do not attempt to disassemble the power supply unit. Do not carry out any work within the **GS1** console while it is powered. The external power supply unit is factory set to match your local a.c. mains supply and marked on the cover. Check that this matches your local mains supply. Check your mains wiring and earthing before switching on.

## CONTENTS

INTRODUCTION .....	2
SERVICE & TECHNICAL SUPPORT .....	2
PRECAUTIONS .....	2
DIMENSIONS .....	3
CONNECTIONS .....	3
TECHNICAL SPECIFICATION .....	4
MIDI IMPLEMENTATION DATA .....	4
CONSOLE FUNCTIONAL CHECK .....	5
CONSOLE DISASSEMBLY .....	7
REMOVING THE CONSOLE CIRCUIT BOARD .....	8
EXPANDER DISASSEMBLY .....	9
REMOVING THE EXPANDER CIRCUIT BOARD .....	10
EXPANDER OPTION FITTING INSTRUCTIONS .....	11
METERBRIDGE OPTION FITTING INSTRUCTIONS .....	12
ORDERING SPARE PARTS .....	16

## TECHNICAL DIAGRAMS

BLOCK DIAGRAM .....	
GS1 CONSOLE CIRCUIT DIAGRAM PCB KEY .....	
PCB COMPONENT LAYOUT - CHANS 1 to 8 .....	
PCB COMPONENT LAYOUT - CHANS 9 to 16 & MASTER L-R .....	
CONSOLE CIRCUIT DIAGRAMS (8 pages) .....	
GS1 EXPANDER CIRCUIT DIAGRAM PCB KEY .....	
EXPANDER PCB COMPONENT LAYOUT .....	
EXPANDER CIRCUIT DIAGRAMS (3 pages) .....	
METERBRIDGE PCB LAYOUT .....	
METERBRIDGE CIRCUIT DIAGRAM .....	

# DIMENSIONS

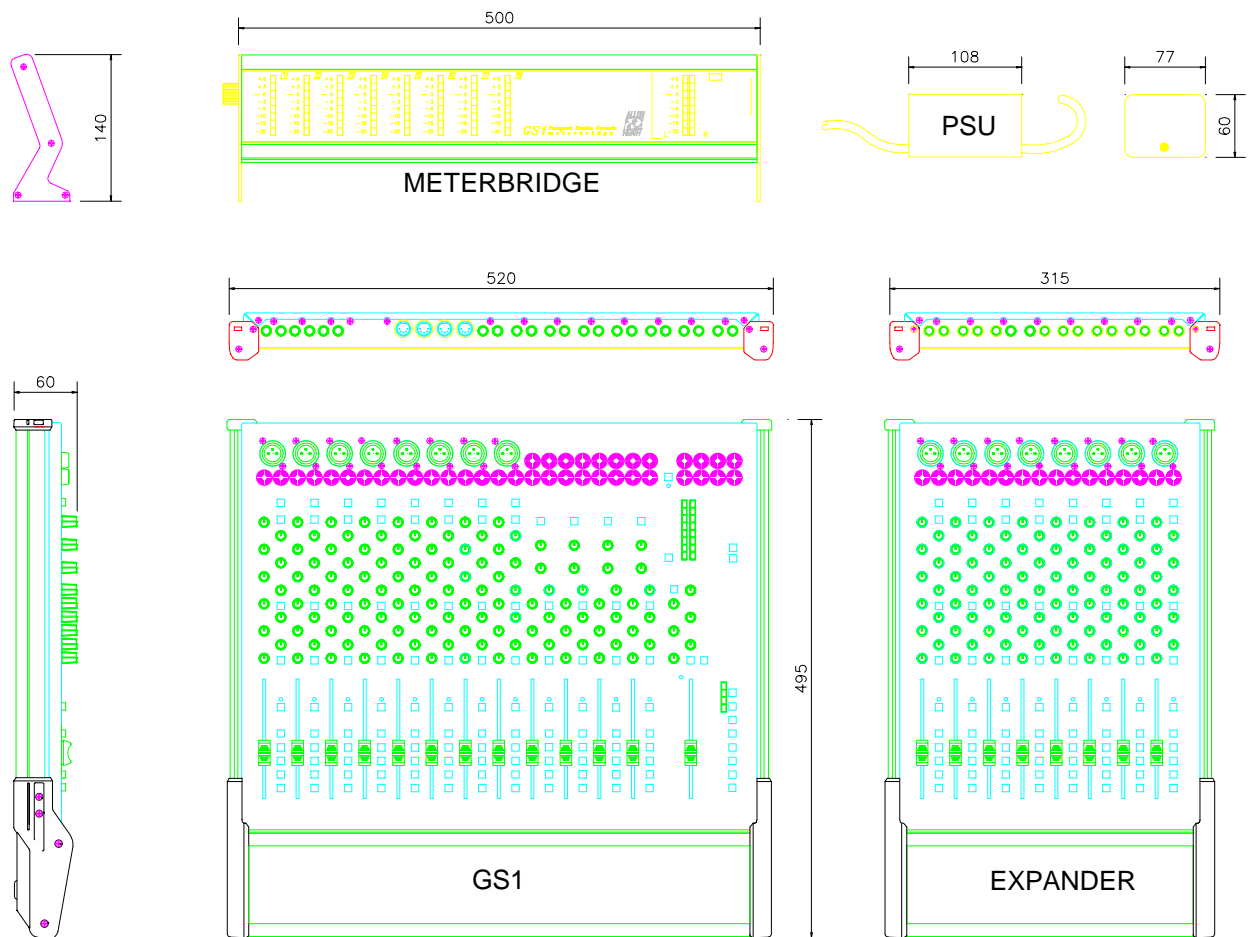

	Dimensions packed			unpacked Kg(lb)	packed Kg (lb)
	W	D	H		
GS1 .....	630	550	140	7.5 (16.5)	10.5 (23.1)
EXPANDER .....	400	550	140	5 (11)	7 (15.4)
METERBRIDGE .....	630	100	140	1.5 (3.3)	2.5 (5.5)
PSU .....	packed with GS1			1 (2.2)	packed with GS1

# CONNECTIONS

**INPUTS:**

MIC IN .....	XLR .....	pin 2 hot, 3 cold balanced .....	>2k ohms .....	variable -60 to -20dBu
LINE IN .....	XLR .....	pin 2 hot, 3 cold balanced .....	>25k ohms .....	variable -30 to +10dBu
LINE IN .....	1/4" JACK .....	tip hot, ring gnd unbalanced .....	>25k ohms .....	variable -30 to +10dBu
STEREO LINE IN .....	1/4" JACKS .....	tip hot, ring gnd unbalanced .....	>10k ohms .....	-10dBV, +4dBu
STEREO RETURN .....	1/4" JACKS .....	tip hot, ring gnd unbalanced .....	>5k ohms .....	-10dBV, +4dBu
2 TRACK RETURN .....	RCA PHONO .....	tip hot, sleeve gnd unbalanced ..	>10k ohms .....	-10dBV, +4dBu
TAPE RETURN .....	RCA PHONO .....	tip hot, sleeve gnd unbalanced ..	>5k ohms .....	-10dBV, +4dBu
INSERT RETURN .....	1/4" JACKS .....	tip send, ring return unbalanced	>5k ohms .....	-10dBV, +4dBu

**OUTPUTS:**

2 TRACK OUT .....	RCA PHONO .....	tip hot, sleeve gnd unbalanced ..	50 ohms .....	-10dBV, +4dBu
GROUP OUT .....	RCA PHONO .....	tip hot, sleeve gnd unbalanced ..	50 ohms .....	-10dBV, +4dBu
AUX OUT .....	1/4" JACKS .....	tip hot, ring gnd unbalanced .....	50 ohms .....	-10dBV, +4dBu
INSERT SEND .....	1/4" JACKS .....	tip send, ring return unbalanced	50 ohms .....	-10dBV, +4dBu
MONITOR OUT .....	RCA PHONO .....	tip hot, sleeve gnd unbalanced ..	50 ohms .....	-10dBV, +4dBu
HEADPHONE .....	1/4" JACK .....	tip L, ring R .....	for stereo headphones 8 to 400 ohms	

# TECHNICAL SPECIFICATION

0 dBu = 0.775 Volts RMS

0 dBV = 1 Volt RMS

Line level options: +4dBu (high level), -10dBV (low level)

MAX OUTPUTS: ..... unbalanced +21 dBu 2kohms max load

FREQUENCY RESPONSE: 10Hz to 30kHz +0/-1dB

METERS: ..... 8 segment bargraphs for L,R

DISTORTION: THD 0.006% Line in to mix out at 1kHz

-20VU to +6VU (peak)

0VU = +4dBu or -10dBV as selected

CROSSTALK: Interchannel better than -75 dB at 1kHz

POWER REQUIREMENTS: ..... 33VA max. at 50/60Hz

NOISE: ..... 22Hz to 22kHz

External power supply with Mains input factory set for local requirements.

MIC EIN -127 dB into 150 ohms

Output supply on 5pin 240deg DIN 33Vac at 900mA

LINE pre-amp at 0dB -88 dBu

MIX noise -82 dBu

PHANTOM POWER: ..... +48V DC at 45mA generated internally

Global +48V ON switch with individual channel disable links.

CONSTRUCTION: ..... All metal chassis with aluminium extrusions on front and sides. Moulded plastic end caps.

# MIDI SPECIFICATION

## Basic GS1 Implementation table

MUTE CHANNEL	MIDI NOTE	HEX	DEC
1	G#0	20	32
2	A0	21	33
3	A#0	22	34
4	B0	23	35
5	C1	24	36
6	C#1	25	37
7	D1	26	38
8	D#1	27	39
9	E1	28	40
10	F1	29	41
11	F#1	2A	42
12	G1	2B	43

## GS1 Expander Implementation table

MUTE CHANNEL	MIDI NOTE	HEX	DEC
EX 1	G#1	2C	44
EX 2	A1	2D	45
EX 3	A#1	2E	46
EX 4	B1	2F	47
EX 5	C2	30	48
EX 6	C#2	31	49
EX 7	D2	32	50
EX 8	D#2	33	51

## Function keys in Patch mode

Fkey	Prog Change Message
1	CF 00
2	CF 01
3	CF 02
4	CF 03
5	CF 04
6	CF 05

## Transmitted Note

The following message is transmitted for a mute key press:

**9n kk v1 kk v2**

n ..... - MIDI channel 16 (fixed)

kk ..... - Note number (see Implementation tables)

v1 ..... = 40H or more ..... Mute ON

..... = 3FH or less ..... Mute OFF

v2 ..... = 0

## Received Note

**9n kk vv**

n ..... - MIDI channel (must be equal to 16)

kk ..... - Note number (see Implementation tables)

w ..... = 40H or more ..... Mute ON

..... = 3FH or less ..... Mute OFF

..... = 0 ..... IGNORED

## Program Changes

In Patch mode, pressing a function key will transmit MIDI Program Change messages as follows:

**Cn p** where,

n ..... - MIDI channel = 16

p ..... - Program Change No.

(see table Function keys in Patch mode)

The console will also recall its stored Patches on receipt of the above message in any mode

## Function keys in MMC mode

FKey	Name	MMC Message
1	LOCATE	F0, 7F, 7F, 06, 44, 02, 00, 08, F7
2	STOP	F0, 7F, 7F, 06, 01, F7
3	PLAY	F0, 7F, 7F, 06, 02, F7
4	REW	F0, 7F, 7F, 06, 04, F7
5	FWD	F0, 7F, 7F, 06, 05, F7
6	SET LOCATE	F0, 7F, 7F, 06, 4C, 02, 08, 01, F7

## Function keys in MIDI mode

FKey	Name	MIDI Mess. (Press)	MIDI Mess. (Release)
1	RECORD	9F 5D 20	9F 5D 00
2	STOP	9F 5F 20	9F 5F 00
3	PLAY	9F 5E 20	9F 5E 00
4	REW	9F 5B 20	9F 5B 00
5	FWD	9F 5C 20	9F 5C 00
6	CYCLE	9F 58 20	9F 58 00

# CONSOLE FUNCTIONAL CHECK

---

The GS1 undergoes several rigorous stages of testing and quality control before being despatched from the factory. The following procedure is offered to the distributor, dealer and customer to confirm that the unit has arrived without damage and in full working order.

## 1. Packing inspection

- 1.1 Check that the **packed unit is intact** and has not suffered unreasonable transit damage.
- 1.2 Carefully open the box and **check the contents**: GS1 console in polythene bag, power unit, User Manual, Brochure, and orange Quality assurance card.

## 2. Cosmetic inspection

- 2.1 Carefully unpack the unit and **check general cosmetic quality**. Check that the plastic end caps and front armrest are securely attached.
- 2.2 **Set the controls ready** for the electrical tests which follow: All faders down, Gains min, EQ mid, Aux min, Level min, Pan mid, switches up.

## 3. Power-up and initial LED test

- 3.1 Check that the power unit is marked with the **correct mains voltage**. Plug the power unit DIN connector into the GS1 AC 36V socket. Plug the power unit mains connector into the local mains outlet.
- 3.2 **Apply mains power**. Check that the **MMC LED** to the left of the mode switch lights. Press the MODE switch and check that the MMC, PATCH and MIDI LEDs light in turn.
- 3.3 Press each CHANNEL ON switch in turn lighting the green **ON LED**. Press again to turn the channel off.
- 3.4 Press each PFL switch and check that the red **PFL ACTIVE LED** lights in each case.
- 3.5 Press the Microphone PHANTOM POWER switch checking that the red **PHANTOM POWER LED** lights. Measure +48V nominal between pin 3 (+ve) and pin 1 (-ve) and between pin 2 (+ve) and pin 1 of each mic XLR.

## 4. Patch Learn check

- 4.1 Press the MODE switch to select Patch mode. Press the **LEARN** switch. The LEARN LED should flash.
- 4.2 Turn all channels ON. Press MMC Function Key **F1**. Now press LEARN again. The Learn LED should go out.  
  
This has **stored a patch** with all channels on which is recalled by pressing function key F1.
- 4.3 Turn all channels off. Test that pressing **F1 turns all channels on**.
- 4.4 **Remove power** from the GS1. Wait about 30 seconds and power on again. Select Patch mode and check that the patch F1 has been 'remembered' with power removed.

## 5. Signal test

The following tests check the audio inputs and outputs for signal flow and quality. This does not test every routing combination but does check that all circuit blocks and input/output connections are working.

The equipment suggested includes a CD player with known good quality music or test signal material, and a stereo amplifier with high quality loudspeakers. Where further technical equipment is available, more accurate and comprehensive testing is possible using a sinewave signal source, dB voltmeter and oscilloscope. This requires the necessary level of technical competence.

- 5.1 Plug CD player left output into TAPE RTN on Channel 1. Start CD playing and raise L-R fader to '0', and raise Channel 1 TAPE RTN Level pot until the L, R meters both read an average '0' (first red LED).  
  
Press the meters Lo switch to check that the meter reading decreases to average around '-10'.
- 5.2 Connect the GS1 2-TRACK outputs to the amplifier/speaker system. Listen for music quality equally out of the L and R speakers. Test the operation of the TAPE RTN Level and Pan pots.  
  
Replug and repeat for Channels 2 to 8.
- 5.3 Plug CD into Channel 1 Mic XLR. Press Line/XLR (pad) switch. Raise channel Fader to '0' and press L-R. Adjust Gain for average '0' meter reading. Listen to music quality. Test Fader, EQ, Pan and Channel On functions.

Replug and repeat for Channels 2 to 8.

- 5.4 Plug CD L and R into Channel 9/10 STEREO RTN jack sockets. Raise and test the RTN Level and Pan pots.

Replug and repeat for Channels 11/12 to 15/16.

- 5.5 Plug CD L and R into Channel 9/10 Stereo Input jack sockets. Raise channel Fader to '0' and press L-R. Test Fader, Hi/Lo switch, EQ, Pan and Channel On functions.

- 5.6 Plug CD into Channel 1 Line input jack socket. Raise Fader to '0', route to 1-2. Link GROUP Out 1 phono socket to TAPE RTN In phono socket. Raise TAPE RTN Level and listen to music quality. This tests the channel routing to Group 1 out (listened to via TAPE RTN).

Test Channel 1 routing to all the groups by replugging the phonos.

- 5.7 Plug the amplifier into AUX Out 1. Use Channel 1 Aux send 1 to test the Aux output with the AUX master pot raised to maximum.

Replug the amplifier and test AUX 2 to 5 outputs.

- 5.8 Replug the amplifier into the Mon Amp L and R outputs, raise the Monitor Level pot and Listen to the Channel 1 Line input routed to L-R. Press Channel 2 PFL. The signal should be cut off. Set Channel 1 Fader to minimum and press Channel 1 PFL. The signal should reappear.

Replug the CD and test the PFL function of all the channels.

- 5.9 Plug CD into 2-TRACK In L and R. Press the 2-TRACK monitor switch and check music quality.
- 5.10 Press the Monitor Output Mute switch. The signal should be muted. Plug a pair of stereo headphones into the GS1 Headphones jack socket and check signal quality.

## 6. Noise test

Remove the test signal source. The following tests listen to the residual noise generated by the GS1 electronics. This is well below the normal signal level of the console and represents the impressive signal-to-noise performance of the GS1.

With the amplifier gain turned up listen to the noise under the conditions set out below.

**WARNING: Because of the high amplifier gain required avoid switching signals to the outputs while listening to noise. Always turn the amplifier down when replugging the output connectors.**

Listen for a smooth residual hiss (white noise). Slight hum may be present on certain outputs but this should be well within the hiss. Excessive hum, buzzing, clicks and popping may represent a problem.

- 6.1 Mon Amp output, all faders down, channel Gains min. Press each channel PFL in turn listening for channel stage noise.
- 6.2 Channel Gains max. Press each PFL. Listen for channel preamp noise.
- 6.3 Replug amplifier to 2-TRACK Out L and R. Listen to noise with L-R fader down.
- 6.4 Raise L-R fader to maximum, all channel faders down, no channels routed.
- 6.5 Route all channels to L-R, raise faders to maximum. Switch each Channel On in turn.
- 6.6 Replug the amplifier to each GROUP and AUX output in turn listening for residual noise quality. Do this with no groups routed, all channel AUX send pots down, and master AUX send pots maximum.

This completes the test.

Check that the unit is clean, controls reset with **faders at maximum** (as required for packing). Repack carefully in the original packing complete with accessories.

Complete the service log with serial number and test details. Inform A&H immediately if any quality problem is noted.

# CONSOLE DISASSEMBLY

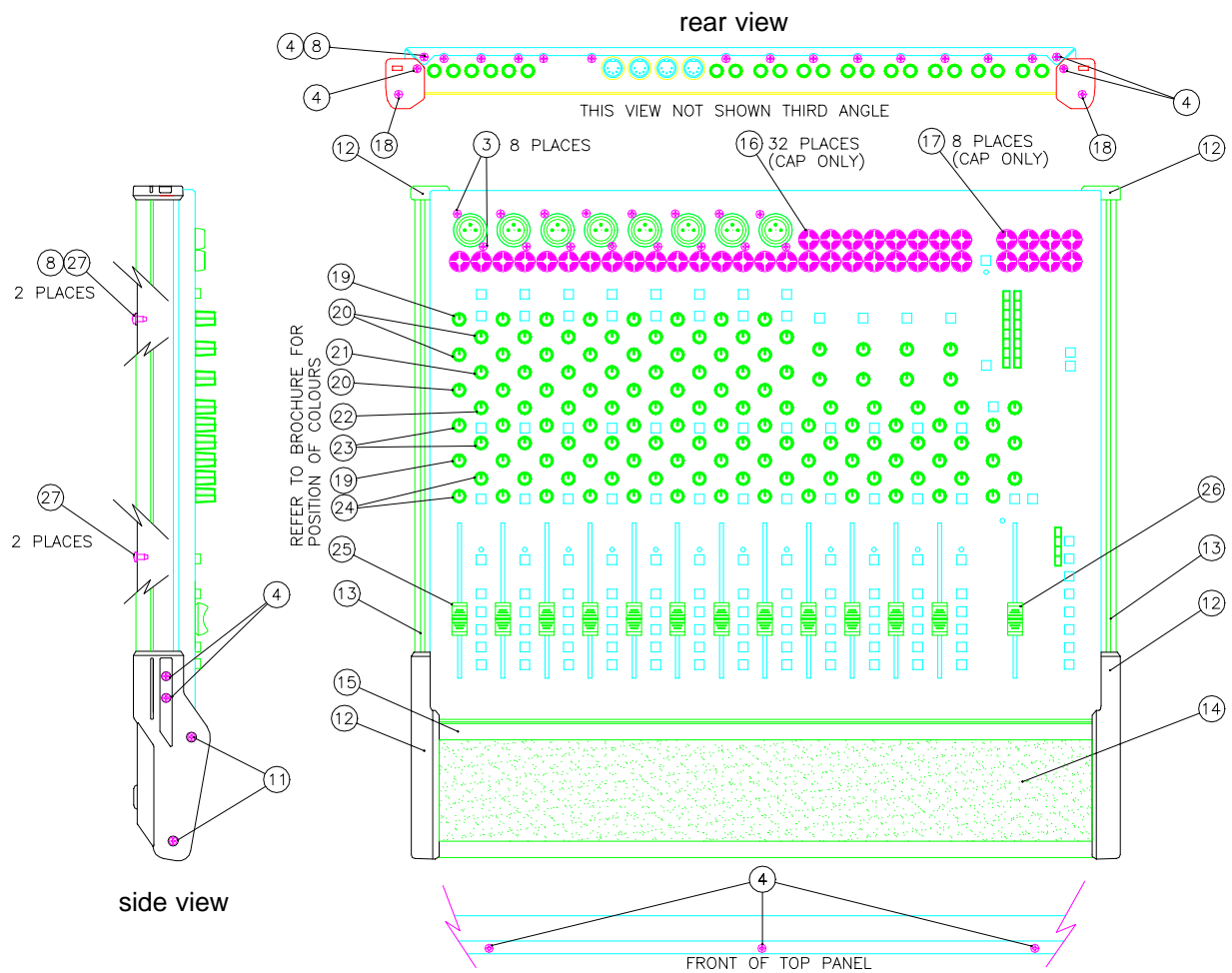

Figure 1.

## Stage 1 - Removing the front panel.

Refer to figure 1.

1. Remove the 4x screws (27) and 2 shakeproof washers (8) from the underside of the side extrusions. (13)
2. Remove the 4x screws (4) from the front end caps. (12)
3. Remove the front extrusion (15) with the plastic front end caps (12) still attached.
4. Remove the 2x screws (4) that attach the rear end caps (12) to the console chassis.
5. Remove the side extrusions (13) with the end caps (12) still attached by sliding them to the rear.
6. Remove the 13x fader knobs (25) and (26).
7. Remove the 126x rotary knobs. (19), (20), (21), (22), (23), (24)
8. Remove the 16x screws (3) from XLR connectors.
9. Using a suitable coin remove the 40x plastic jack nuts (16) & (17) by rotating the nut 45 degrees counter-clockwise.
10. Working from the rear of the unit remove the 2x screws (4) and 1 shakeproof washer (8) that attach the top panel to the base.
11. Working from the front of the unit remove the 3x screws (4) that attach the top panel to the base.
12. You can now lift the top panel off.

Re-assembly is the reverse of the above procedure, taking care to ensure that LEDs and switch caps fit through the top panel correctly.

## Stage 2 - Removing the PCB.

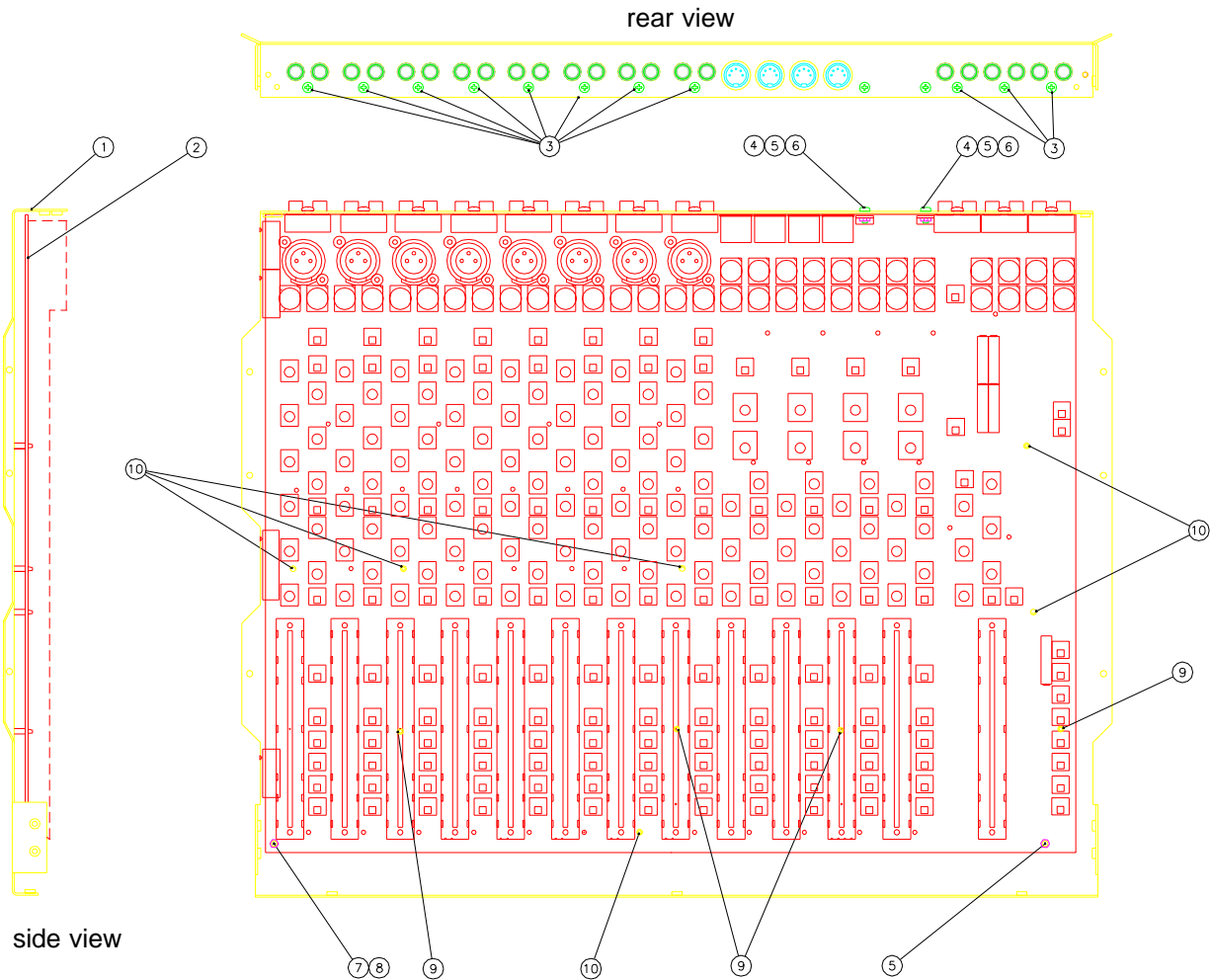

Figure 2.

Refer to figure 2.

1. Remove the 2x screws (4), the 2 locknuts (5) and the 2 plastic insulators (6) that attach the regulators to the rear panel.
2. Remove the 11x screws (3) from the phono connectors along the rear panel.
3. Remove the locknut (5) from front right stud.
4. Remove the nut (7) and shakeproof washer (8) from front left stud.
5. Carefully ease the PCB off the 6 plastic snap-in supports (10) by squeezing together top of supports with pliers or suitable tool.

Re-assembly is the reverse of the above procedure taking care to:

- a) Push the PCB down over all of the plastic snap-in supports.
- b) Insulate the regulators from chassis base as follows:
  1. Fit the grey insulator pads between the regulator and rear panel ensuring correct alignment with the regulator and with hole in rear panel
  2. Insert the black plastic insulator into the hole of the regulator and the hole in the grey insulator pad and rear panel
  3. Push the screw through the black plastic insulator from the rear panel
  4. Fix locknut on to the screw from the regulator side



# EXPANDER DISASSEMBLY

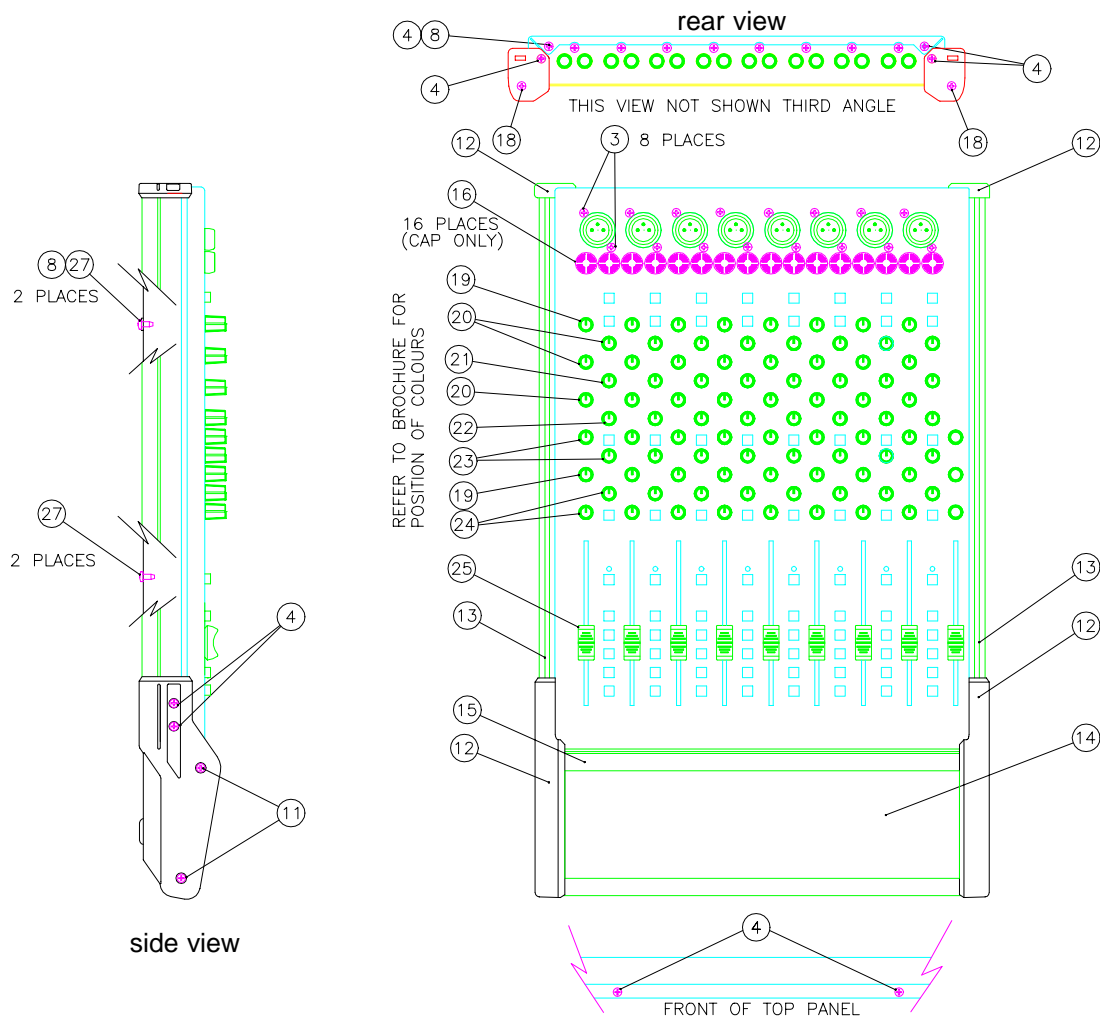

Figure 3.

## Stage 1 - Removing the front panel.

Refer to figure 3.

1. Remove the 4x screws (27) and 2 shakeproof washers (8) from the underside of the side extrusions. (13)
2. Remove the 4x screws (4) from the front end caps. (12)
3. Remove the front extrusion (15) with the plastic front end caps (12) still attached.
4. Remove the 2x screws (4) that attach the rear end caps (12) to the console chassis.
5. Remove the side extrusions (13) with the end caps (12) still attached by sliding them to the rear.
6. Remove the 8x fader knobs. (25)
7. Remove the 88x rotary knobs. (19), (20), (21), (22), (23), (24).
8. Remove 16x screws (3) from XLR connectors.
9. Using a suitable coin remove the 16x plastic jack nuts (16) by rotating the nut 45 degrees counter-clockwise.
10. Working from the rear of the unit remove the 2x screws (4) and 1 shakeproof washer (8) that attach the top panel to base.
11. Working from the front of the unit remove the 2x screws (4) that attach the top panel to the base.
12. You can now lift the top panel off.

Re-assembly is the reverse of the above procedure, taking care to ensure that LEDs and switch caps fit through the top panel correctly.

## Stage 2 - Removing the PCB.

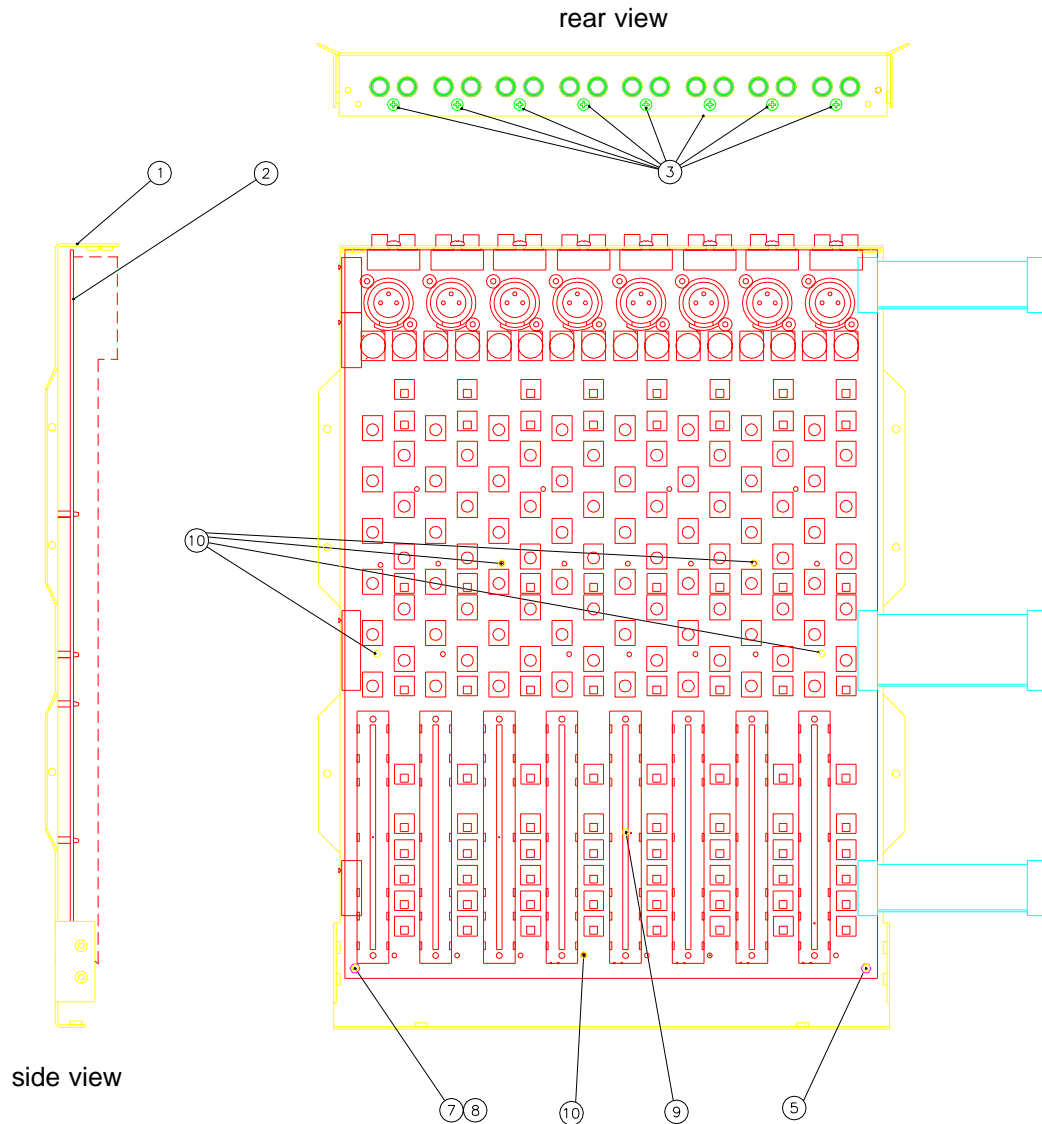

Figure 4.

Refer to figure 4.

1. Remove the 8x screws (3) from the phono connectors along the rear panel.
2. Remove the locknut (5) from the front right stud.
3. Remove the nut (7) and shakeproof washer (8) from the front left stud.
4. Carefully ease the PCB off the 6 plastic snap-in supports (10) by squeezing together top of supports with pliers or suitable tool.

Re-assembly is the reverse of the above procedure taking care to push PCB down over all plastic snap-in supports.

# EXPANDER OPTION FITTING INSTRUCTIONS

The GS1 Expander Unit adds a further 8 channel strips giving 16 extra inputs.

Please read the following instructions carefully before attempting to fit the Expander.

## **Disconnect GS1 from Power Supply Unit and cables before fitting expander**

- 1 Remove screws from left hand extrusion and rear end cap of GS1 and slide out extrusion as shown. It may be necessary to loosen screws "A" to enable extrusion to slide.

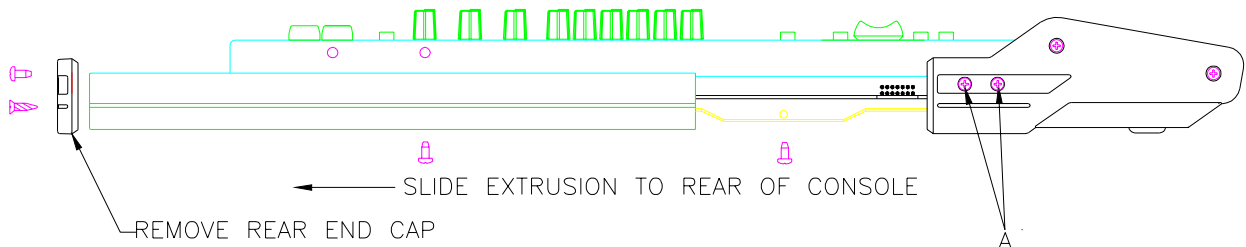

- 2 Connect expander ribbon cables to the GS1 as shown. Note that the rear ribbon cable fits to the outside connector. The adjacent connector is for the optional Meterbridge.

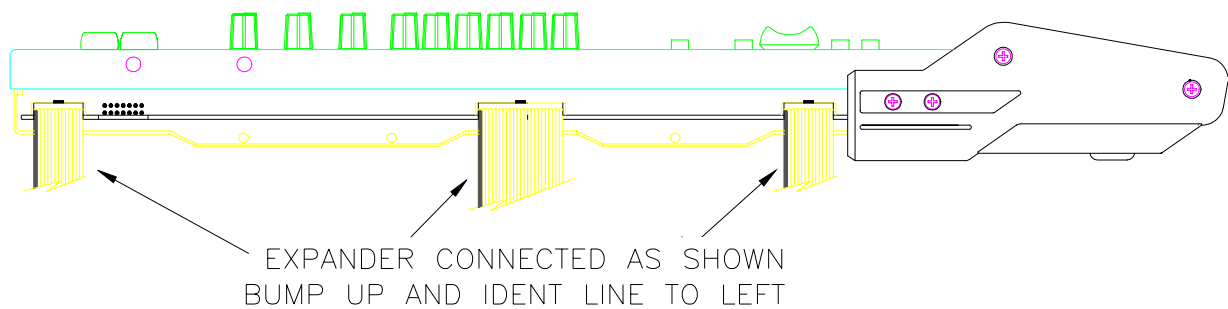

- 3 Replace extrusion and rear end cap taking care not to trap the ribbon cables.

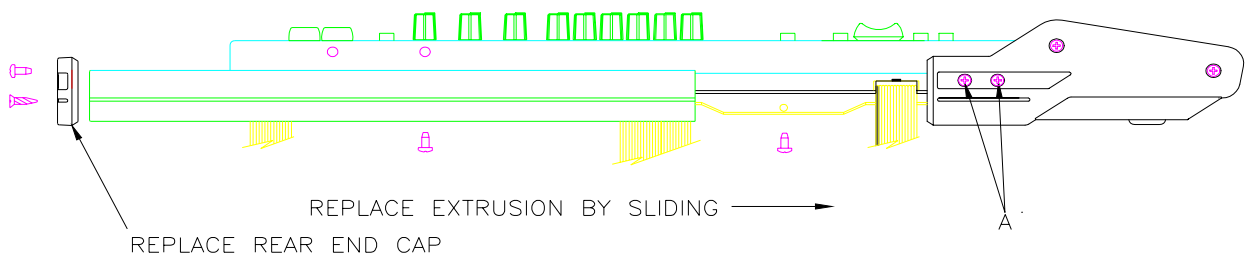

## TESTING THE EXPANDER

After connection of the expander reconnect the PSU and carry out the following checks.

Press Channel On switches on expander and check corresponding LED's light and extinguish on alternate presses.

Connect inputs to expander and check that they can be routed to Left, Right and Group outputs as required.

### **NOTE.**

Take care not to strain the ribbon cables when moving the expanded Console.

# METERBRIDGE OPTION FITTING INSTRUCTIONS

The GS1 Meterbridge option provides the user with full Group and Left/Right metering. The Meterbridge has been designed to fit either at the rear of the console on the supports provided or at the front as a replacement for the existing armrest.

Please read the following instructions carefully before attempting to fit the Meterbridge.

## Remove the console Power Supply lead and audio cables before fitting the meterbridge

- 1 Check contents of pack to ensure all parts have been supplied



PART NO. AB0074  
 QUANTITY 4  
 SCREW 3MM X 8 CSK

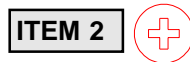

PART NO. AB0195  
 QUANTITY 4  
 SCREW SELF TAP

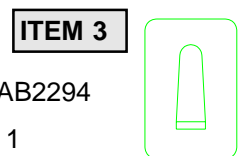

PART NO. AB2294  
 QUANTITY 1  
 CABLE CLIP IDC



PART NO. AA2178  
 QUANTITY 1  
 FACIA (SELF ADHESIVE)

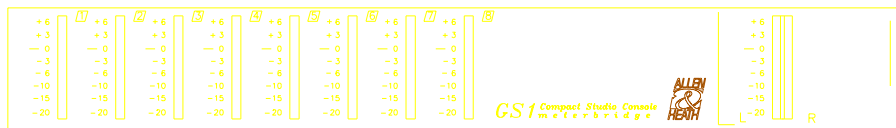

PART NO.s 002-052,AA2177  
 QUANTITY 1  
 FRONT PANEL ASSY

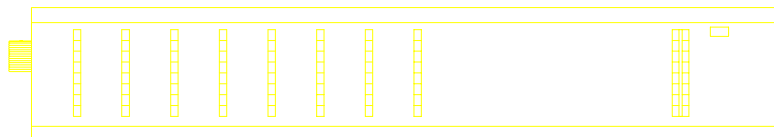

PART NO.s AA2256,AA2257  
 QUANTITY 1  
 SIDE TRIMS L/H R/H



PART NO. AA2166  
 QUANTITY 1  
 EXTRUSION

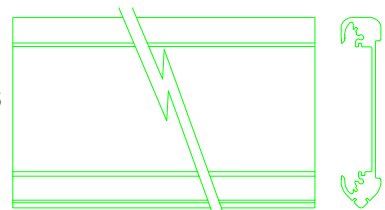

(SUPPLIED FITTED TO ITEM 5)

## ASSEMBLY (REAR POSITION)

As supplied the front panel and PCB are assembled in the extrusion the correct way round for mounting at the rear of the console.

- 2 Attach side trims **ITEM 6** to the extrusion **ITEM 7** using the self tapping screw supplied **ITEM 2**. The Left hand side trim has a rebate for the IDC cable. Care should be taken not to trap the cable when attaching the side trim.

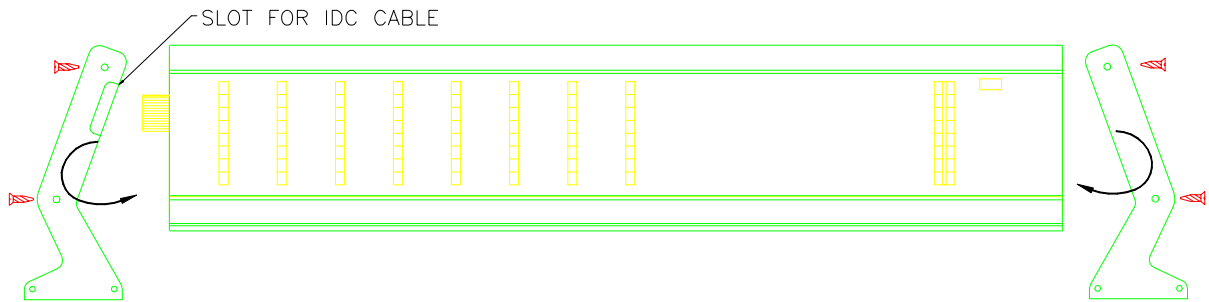

- 3 Apply self adhesive facia **ITEM 4** to the front panel **ITEM 5** ensuring correct alignment with the meter slots.

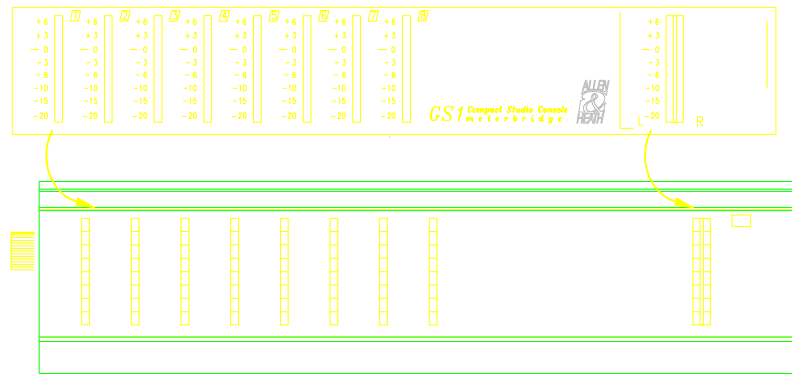

- 4 Remove screws from left hand extrusion and plastic end cap and slide out extrusion as shown. It may be necessary to loosen screws "A" to enable side extrusion to slide.

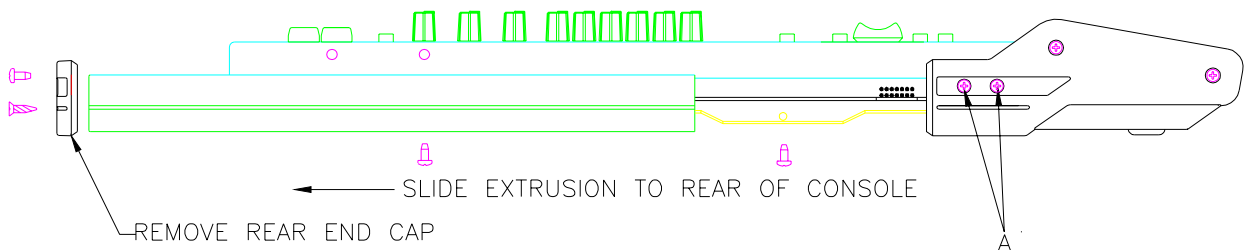

- 5 Attach Meterbridge to sides of front panel as shown in using M3 screws supplied **ITEM 1**. Connect IDC cable as shown ensuring correct orientation.

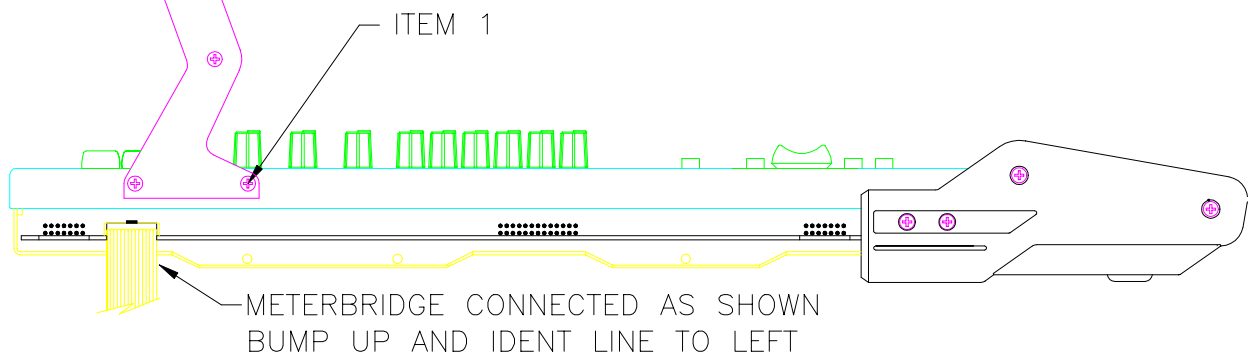

- 6 Apply the self adhesive cable clip **ITEM 3** as shown in the diagram.  
Route cable as shown below. Replace side extrusion and rear end cap.

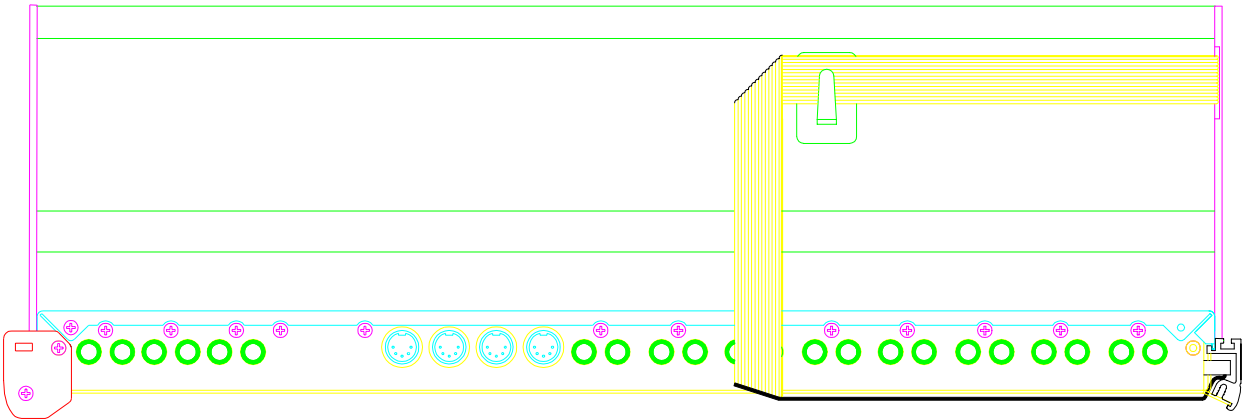

The installation is now complete. Replug the console and test for correct operation.

## ASSEMBLY (ARMREST POSITION)

- 2 To assemble the Meterbridge in the armrest position the Front Panel/PCB assembly **ITEM 5** must be removed from the extrusion **ITEM 7** and replaced the opposite way round.

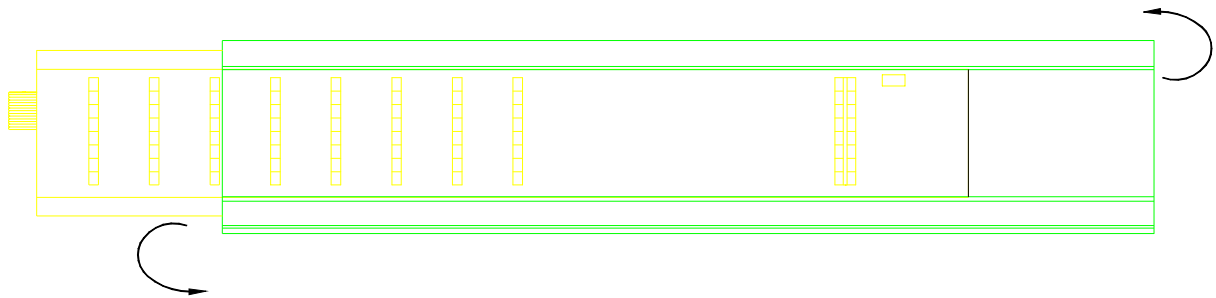

- 3 When replaced the self adhesive Facia **ITEM 4** can be applied to the front panel **ITEM 5** ensuring correct alignment with the meter slots.

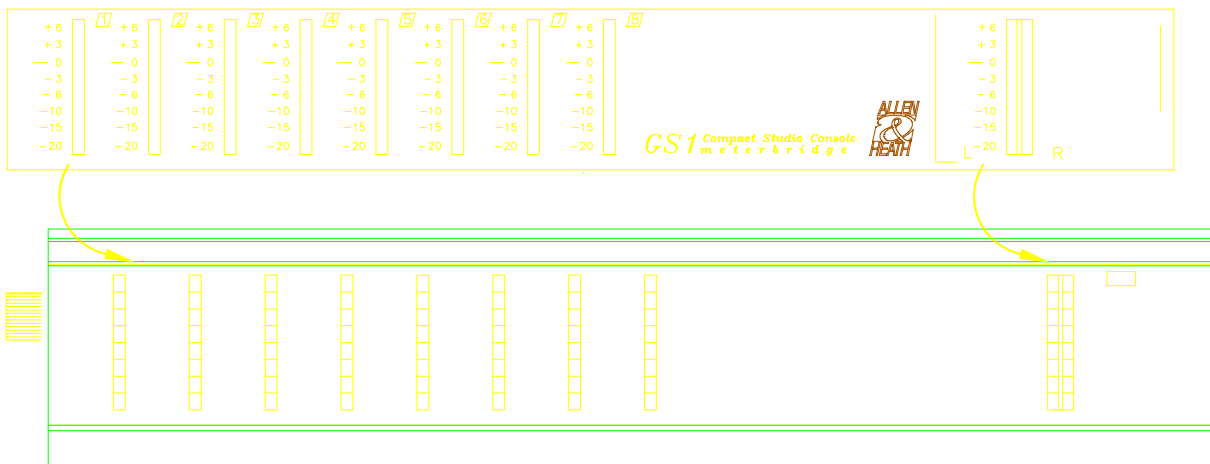

- 4** Remove screws from left hand extrusion and plastic end cap and slide out extrusion as shown.  
Remove left hand front end cap held by screws "A" and "B"

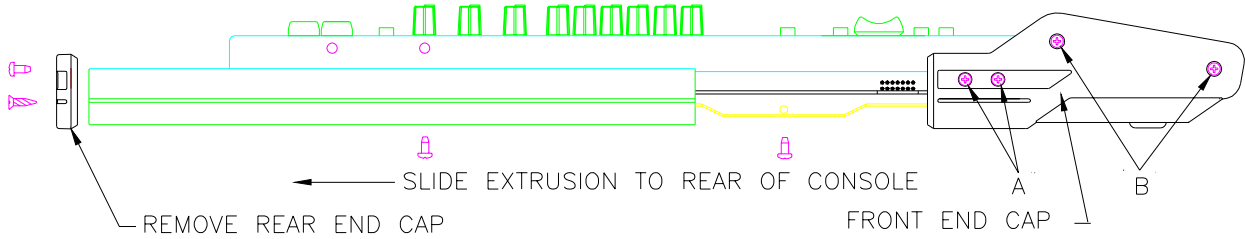

- 5** Release screws "B" from right hand front end cap and remove existing armrest.  
Insert Meterbridge into right hand front end cap, replace left hand front end cap ensuring IDC cable exits through the slot in the end cap.

Route IDC cable under console and connect as detailed previously in step **5** of rear position assembly instructions

Replace side extrusion and rear end cap.

The IDC cable clip **ITEM 3** may be used on base of console to keep IDC cable neat.

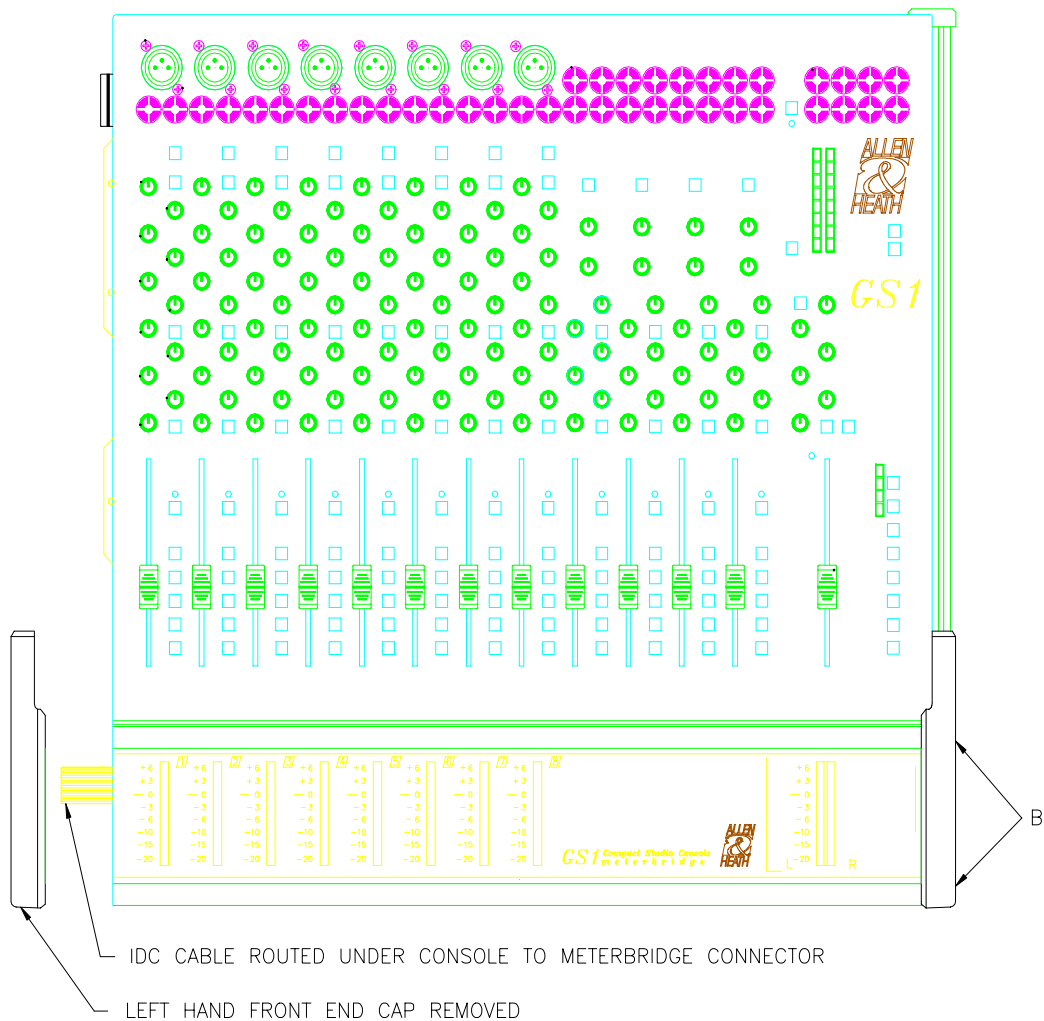

The installation is now complete. Replug the console and test for correct operation.

## **ORDERING SPARE PARTS**

### **ORDERING A CONSOLE**

<u>MODEL</u>	<u>DESCRIPTION</u>	<u>ORDER CODE</u>
GS1 240V	16 channel GS1 + PSU (240V)	GS1/240
GS1 220V	16 channel GS1 + PSU (220V)	GS1/220
GS1 120V	16 channel GS1 + PSU (120V)	GS1/120
GS1 110V	16 channel GS1 + PSU (110V)	GS1/110
GS1 100V	16 channel GS1 + PSU (100V)	GS1/100

### **ORDERING AN OPTION**

<u>MODEL</u>	<u>DESCRIPTION</u>	<u>ORDER CODE</u>
GS1 EXPANDER	8 channel Expander	GS1-EX
GS1 METERBRIDGE	Group & L/R meterbridge	GS1-MP

### **ORDERING A POWER SUPPLY**

<u>MODEL</u>	<u>DESCRIPTION</u>	<u>ORDER CODE</u>
240V	240V Power Supply unit	AM2211
220V	220V Power Supply unit	AM2212
115V	120V and 110V Power Supply Unit	AM2213
100V	100V Power Supply Unit	AM2214

### **MANUALS AND SUPPORT DOCUMENTATION**

<u>DESCRIPTION</u>	<u>ORDER CODE</u>
GS1 User Guide	AP2061
GS1 Service Manual	AP2064
GS1 Expander Fitting Instructions	AP2313
GS1 Meterbridge Fitting Instructions	AP2300

### **SERVICE TOOLS**

<u>DESCRIPTION</u>	<u>ORDER CODE</u>
1-point Crosshead screwdriver (M3, 4AB)	AT0004

### **SOFTWARE UPGRADE:**

The GS1 software is stored in a Microcontroller which is socketed. To replace the Microcontroller the console will have to be disassembled as detailed in Stage 1 of the CONSOLE DISASSEMBLY section of this manual.

To order a replacement, please contact ALLEN & HEATH and notify us of your console serial number, its present Microcontroller version and code number, and reason for replacement.



## **ORDERING A SPARES KIT**

It is recommended that the spares kit order code 002-014 is held and maintained by the service agent to enable in-field service repairs to the GS1 independent of the ALLEN & HEATH factory. Commonly available items such as resistors, capacitors, tools and soldering equipment are not included. The contents of the kit is listed here. Individual spare parts may be ordered. Please quote the description and order code for the part required.

## **DESCRIPTION ORDER CODE QTY**

### **Fixings:**

Screw 4AB x 5/16" Pan Pozi Black	AB0057	10
Screw 6AB x 3/8" Pan Pozi Black	AB0062	5
Screw M3 x 8mm Pan Pozi Black	AB0073	10
Screw 6B x 1/4" Pan Pozi Black	AB2224	5
Nylock nut M3	AB0102	5
Washer M3 shakeproof	AB0244	5
Pillar Support 6.4mm	AB2171	5
Pillar snap-in 6.4mm	AB2233	5
Spacer M3 x 6.4mm	AB2218	5

### **Knobs and caps**

Fader knob white+black line	AJ2163	10
Fader knob red+white line	AJ2164	5
Rotary knob grey+red top	AJ2188	10
Rotary knob grey+blue top	AJ2194	10
Rotary knob grey+green top	AJ2195	5
Rotary knob grey+dark grey top	AJ2196	10
Rotary knob grey+yellow top	AJ2197	10
Rotary knob grey+brown top	AJ2198	10
Switch Button	AJ8071	10

### **Potentiometers, switches and connectors**

Fader 10kA 100mm ALPS - MONO	AI8055	5
Fader 10kAx2 100mm ALPS - STEREO & LR	AI8056	5
Rotary 200kC stereo - MID SWEEP	AI2042	3
Rotary 5kRD - MIC GAIN	AI8059	5
Rotary 20kB centre click - HF,MF,LF	AI8060	10
Rotary 20kK - AUX 2/4, 3/5, TAPE RTN LEV, AUX MASTERS	AI8061	10
Rotary 5kB centre click - PAN	AI8062	5
Rotary 20kK stereo - AUX 1, STEREO RTN LEV & MONITOR LEV	AI8063	10
Rotary 20kBx2 - STEREO HF & LF	AI8064	5
Switch 2PCO latching	AL8057	5
Switch 2PCO momentary	AL8058	5
Jack socket - LINE, INSERT, STR RETURN	AL8072	5
Jack socket - AUX OUTS, HPHONES	AL8073	5
XLR 3 Pin Female - MIC	AL8074	5
Dual Phono socket - TAPE IN/OUT, LR OUT	AL0577	3
DIN 5 Pin 180° - MIDI	AL0095	1
DIN 5 Pin 240° - CONSOLE POWER	AL2113	-

### **LEDs and Semiconductors**

LED 3mm T1 Green	AE0085	5
LED 3mm T1 Red	AE0086	3
LED Bar 4x Green	AE0303	2
LED Bar 1x Green + 3x Red	AE0347	1
Transistor BC214C PNP	AE0031	5
Transistor BC546C NPN	AE2253	5
Transistor 2SB737 PNP	AE8069	5
Transistor J111 FET	AE0083	5
IC NE5532N Dual Op Amp	AE0221	5

**DESCRIPTION****ORDER CODE QTY**

IC TLO72 Dual Op Amp (SIL Package)	AE8070	5
IC LM339 Quad Comparator	AE0071	2
IC CMOS 4053B	AE0117	1
IC CMOS 4051B	AE0118	1
IC CMOS 4099B	AE0238	1
IC 6N136 Opto isolator	AE0222	1
IC Regulator 7815 (+15V DC)	AE0047	1
IC Regulator 7915 (-15V DC)	AE0048	1
IC Regulator 783 (+48V DC)	AE0214	1
IC CMOS 74HC4051SMD (Expander only)	AE2161	-
IC CMOS 74HCF4099 SMD (Expander only)	AE2162	-
IC TL072 Dual Op Amp (DIL Package) (Expander only)	AE0046	-

**MISCELLANEOUS**

Insulating Kit (voltage regulators)	AA0693	2
Plastic End Cap set - front & rear, L&R	AA2168	-
Packaging (box, lid & fittings)	AN2072	-
Expander Harness 16way IDC	AL2119	-
Expander Harness 26way IDC	AL2154	-
Meterbridge Harness 16way IDC	AL2155	-

# **TECHNICAL DIAGRAMS**

**This section includes the circuit diagrams and illustrations plus any technical bulletins**

# GS1 CONSOLE CIRCUIT DIAGRAM PCB KEY & LINK OPTION POSITIONS

The areas outlined on the PCB correspond to the sheet number on the circuit diagram C2018. For a detailed PCB component ident refer to PCB fig I and fig II on the following pages.

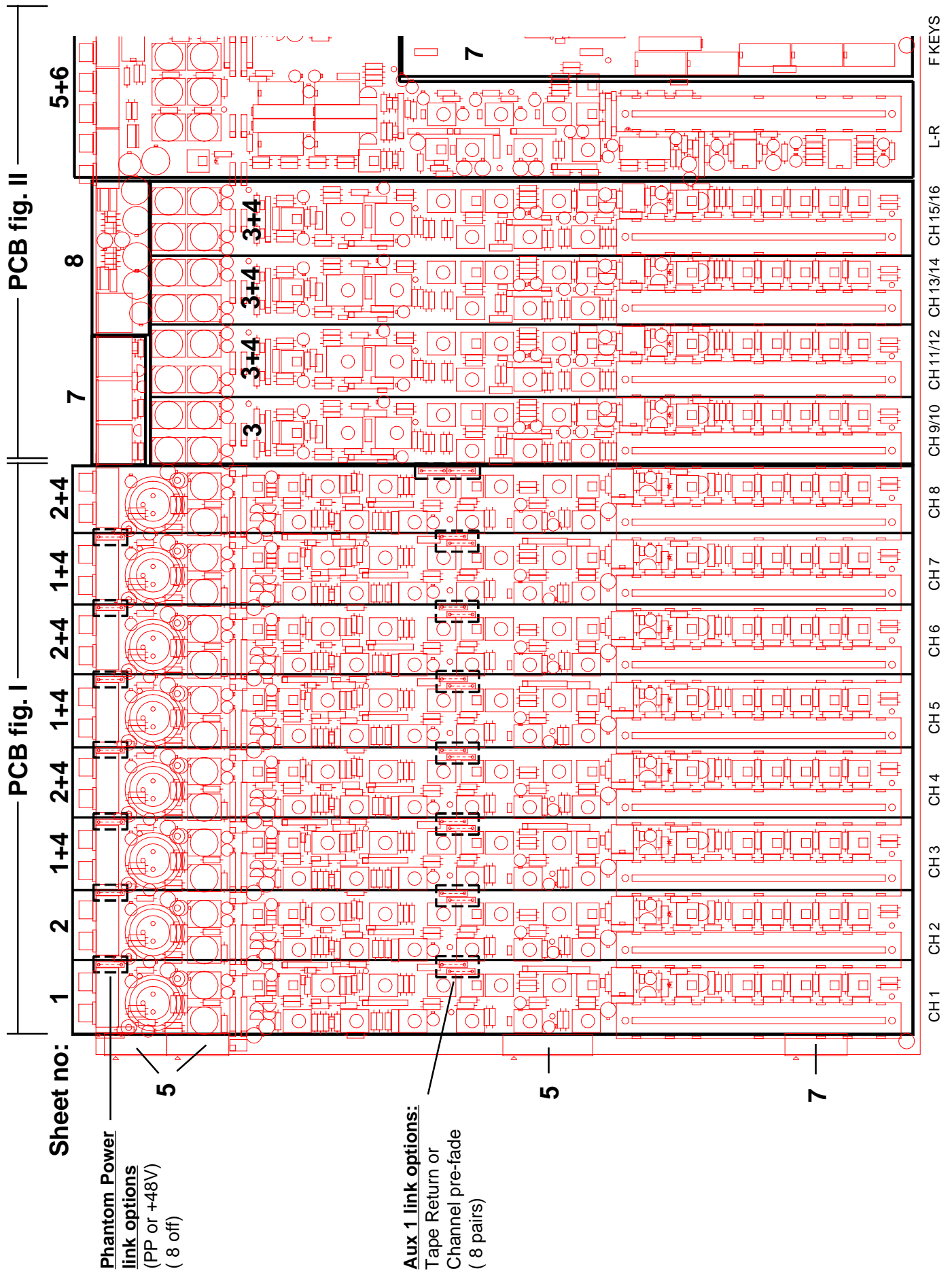

# GSI

## BLOCK DIAGRAM

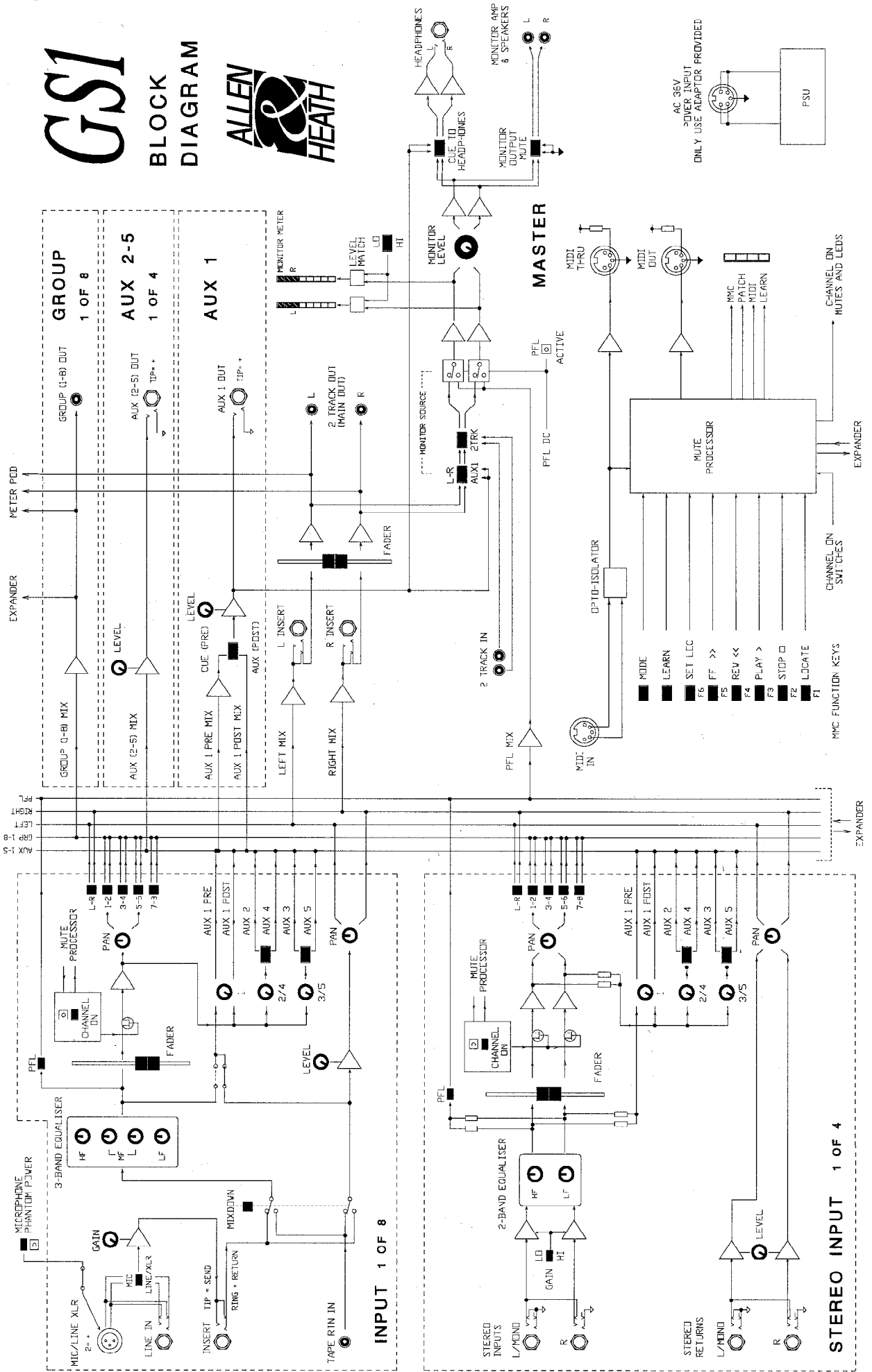

# PCB COMPONENT LAYOUT FOR CHANNELS 1 TO 8

PCB fig.I

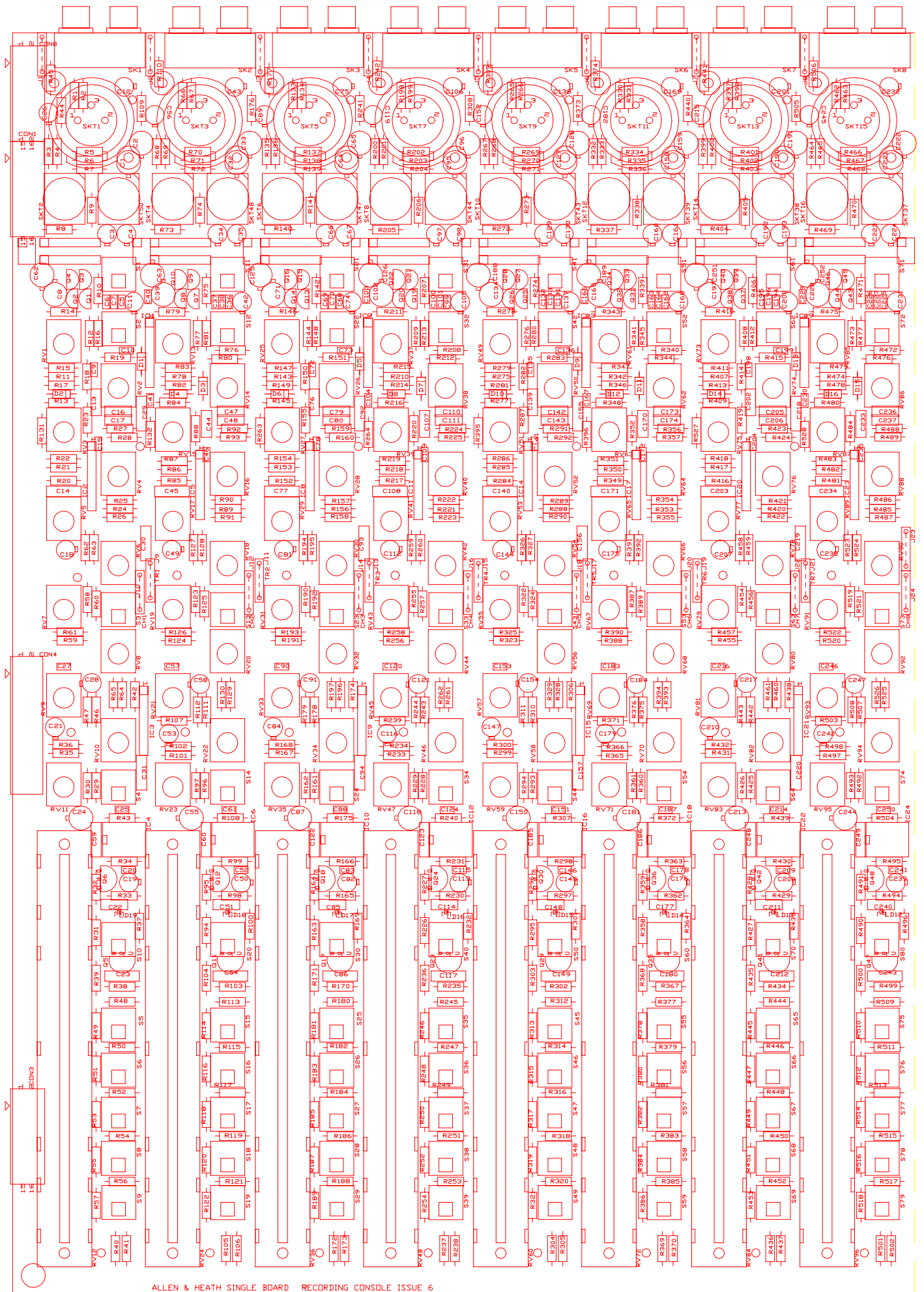

# PCB COMPONENT LAYOUT FOR CHANNELS 9 TO 16 & MASTER L-R

PCB fig.II

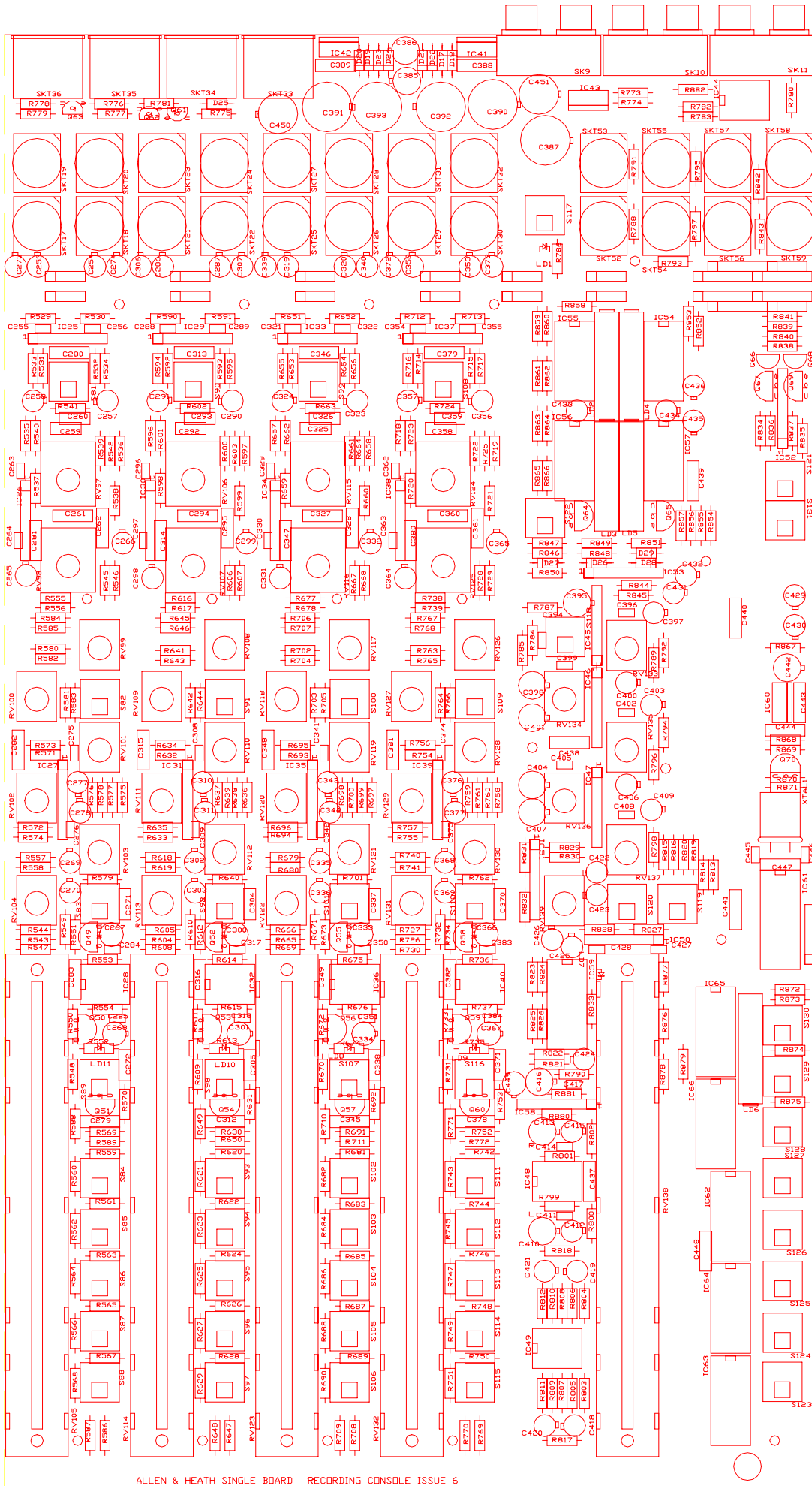

ALLEN & HEATH SINGLE BOARD RECORDING CONSOLE ISSUE 6

COMP PRINT AG2018L00

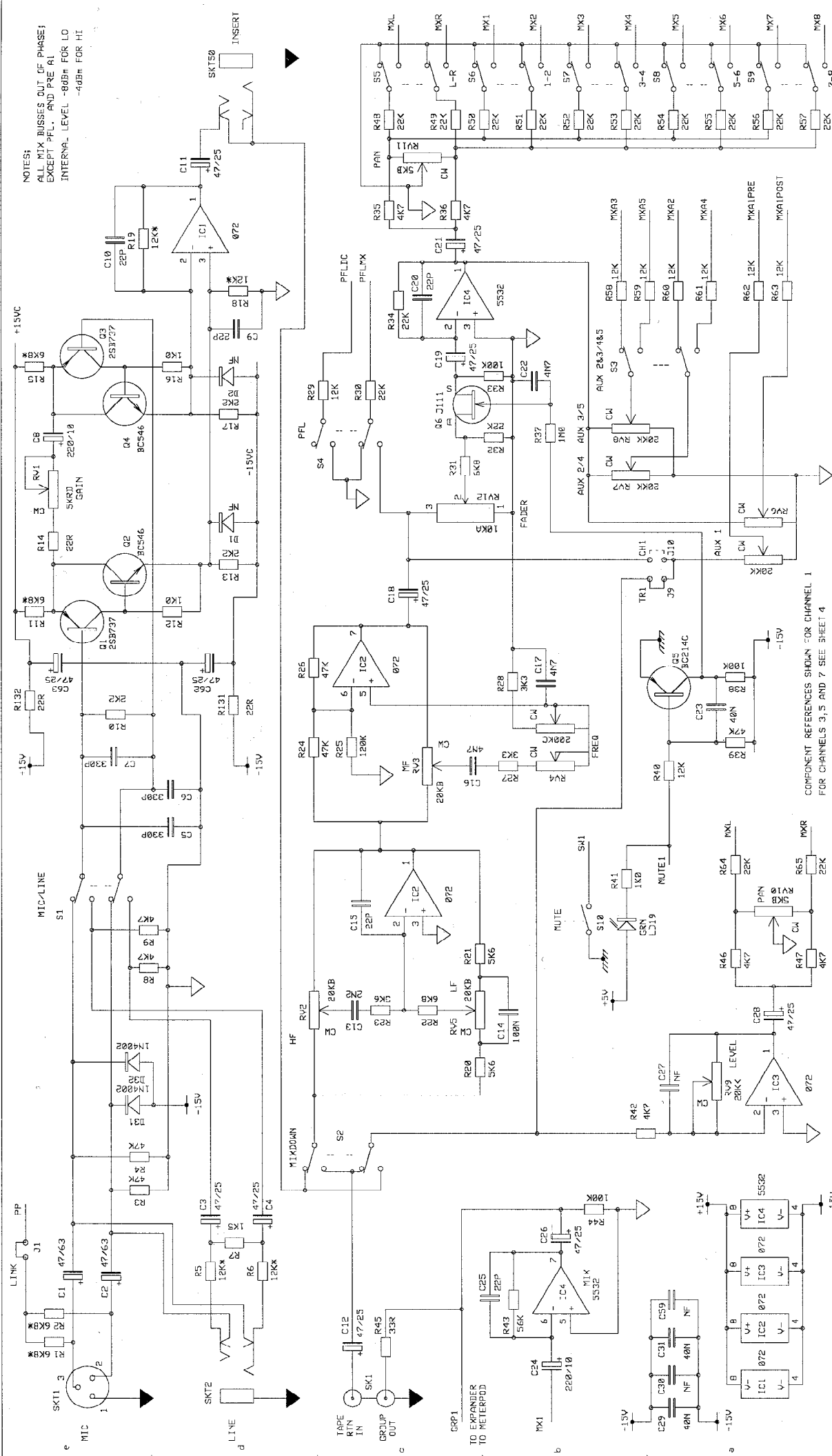

NOTES:  
 ALL MIX BUSES OUT OF PHASE;  
 EXCEPT PFL, AND PRE AL  
 INTERNAL LEVEL -80dBm FOR LO  
 -40dBm FOR HI

MANUFACTURED IN ENGLAND BY

ALLEN & HEATH

DRAWING No. C2018  
 ISSUE 2

UNIT TITLE  
 SHT 1 OF 8

DRAWING TITLE  
 GS1 MONO INPUT CIRCUIT

ODD CHANNELS 1,3,5 AND 7

NOTES

1. RESISTORS MARKED \* ARE 1%  
 ALL OTHERS ARE 5% 1/4W UNLESS  
 OTHERWISE MARKED
2. ELECTROLYTIC CAPACITORS ARE  
 50V UNLESS OTHERWISE MARKED

BY DATE

DL3 29/3/95  
 DL5 2/5/95

REVISION

ORIGIN  
 UPDATES

ISS.

1  
 2

COMPONENT REFERENCES SHOWN FOR CHANNEL 1  
 FOR CHANNELS 3,5 AND 7 SEE SHEET 4

A B C D E



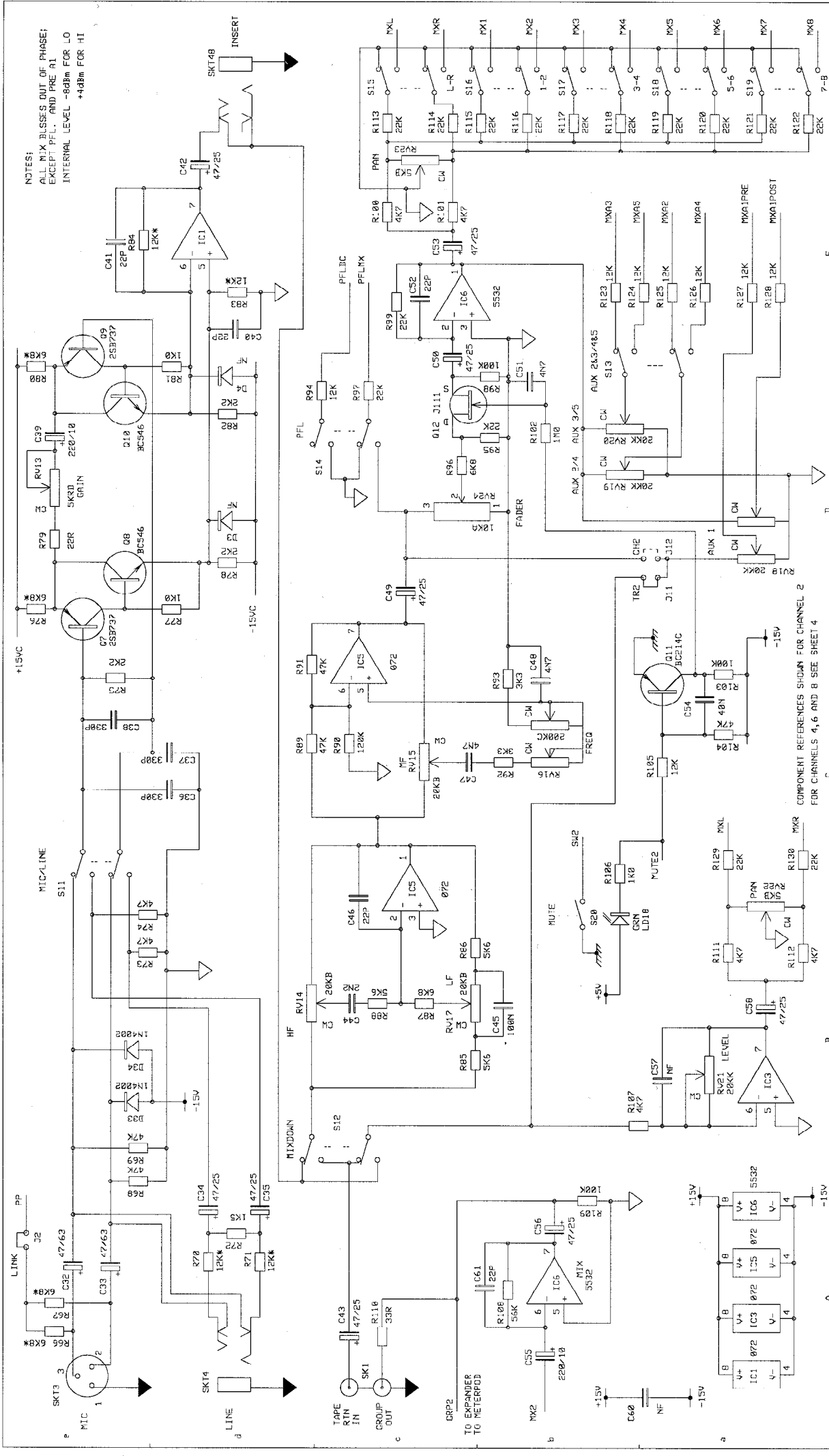

NOTES:  
 ALL MIX BLASSES OUT OF PHASE!  
 EXCEPT PFL AND PRE AL  
 INTERNAL LEVEL -80dbm FOR LO  
 +14dbm FOR HI

MANUFACTURED IN ENGLAND BY

ALLEN & HEATH

DRAWING No. C2018

ISSUE 2

SHT 2 OF 8

DRAWING TITLE

GS1 MONO INPUT CIRCUIT  
 EVEN CHANNELS 2, 4, 6 AND 8

NOTES

1. RESISTORS MARKED \* ARE 1% ALL OTHERS ARE 5% 1/4W UNLESS OTHERWISE MARKED
2. ELECTROLYTIC CAPACITORS ARE  $\mu$ F/VOLTS

REVISION BY DATE

1 DLP 25/3/95  
 2 DLP 2/5/95

ORIGIN UPDATES

A3

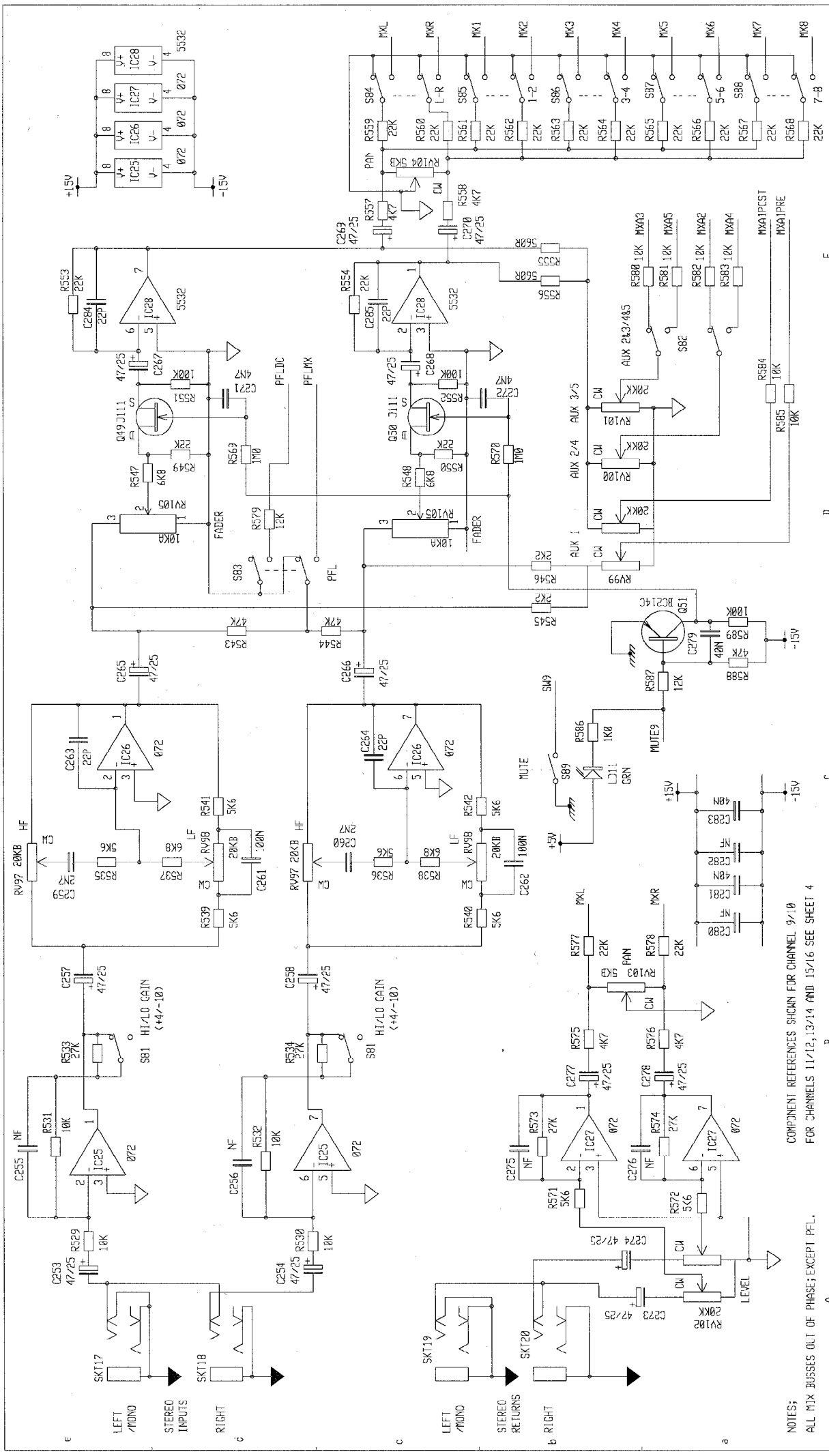

<p>ISS. 1 2</p>		<p>REV. DATE ORIGIN UPDATES</p>	<p>BY DATE DLP 29/3/95 DLP 2/5/95</p>	<p>UNIT TITLE DRAWING TITLE</p>	<p>SHT 3 OF 8</p>	<p>MANUFACTURED IN ENGLAND BY ALLEN &amp; HEATH</p>
<p>NOTES</p> <p>1. RESISTORS MARKED * ARE 1% ALL OTHERS ARE 5% 1/4W UNLESS OTHERWISE MARKED ELECTROLYTIC CAPACITORS ARE µF/VOLTS</p>				<p>DRAWING No. C2018</p>		<p>ISSUE 2</p>
<p>COMPONENT REFERENCES SHOWN FOR CHANNEL 9/1/0 FOR CHANNELS 11/12, 13/14 AND 15/16 SEE SHEET 4</p>				<p>ALL MIX BUSES OUT OF PHASE; EXCEPT PFL.</p>		

PREFIX	ODD MONO CHANNELS			EVEN MONO CHANNELS			STEREO CHANNELS		
	CH3	CH5	CH7	CH4	CH6	CH8	CH11/12	CH13/14	CH15/16
C	+63	+126	+189	+63	+126	+189	+33	+66	+99
D	+4	+8	+12	+4	+8	+12	-	-	-
IC	+6	+12	+18	+6	+12	+18	+4	+8	+12
LD	-2	-4	-6	-2	-4	-6	-1	-2	-3
Q	+12	+24	+36	+12	+24	+36	+3	+6	+9
R	+132	+264	+396	+132	+264	+396	+61	+122	+183
RY	+24	+48	+72	+24	+48	+72	+9	+18	+27
S	+20	+40	+60	+20	+40	+60	+9	+18	+27
SK	+2	+4	+6	+2	+4	+6	-	-	-
SKT	+4	+8	+12	+4	+8	+12	+4	+8	+12

TO TRANSLATE COMPONENT REFERENCE NUMBERS FROM THE RELEVANT CIRCUIT DIAGRAM

ADD OR SUBTRACT THE APPROPRIATE NUMBER SHOWN IN THE TABLE ABOVE

FOR EXAMPLE IC1 ON CHANNEL 1 (MONO ODD CHANNEL CIRCUIT DIAGRAM) BECOMES IC19 ON CHANNEL 7

ISS.	1	REVISION	BY	DATE	A	B	C	D	E
	2	ORIGIN UPDATES	DLP	29/3/95					
NOTES					UNIT TITLE		SHT 4 OF 8		
1. RESISTORS MARKED * ARE 1% ALL OTHERS ARE 5% 1/4W UNLESS OTHERWISE MARKED					DRAWING TITLE				
2. ELECTROLYTIC CAPACITORS ARE µF/VOLTS					GS1 MONO AND STEREO CHANNEL TRANSLATION TABLES				
MANUFACTURED IN ENGLAND BY									
ALLEN & HEATH									
DRAWING No. C2018									
ISSUE 2									
A3									

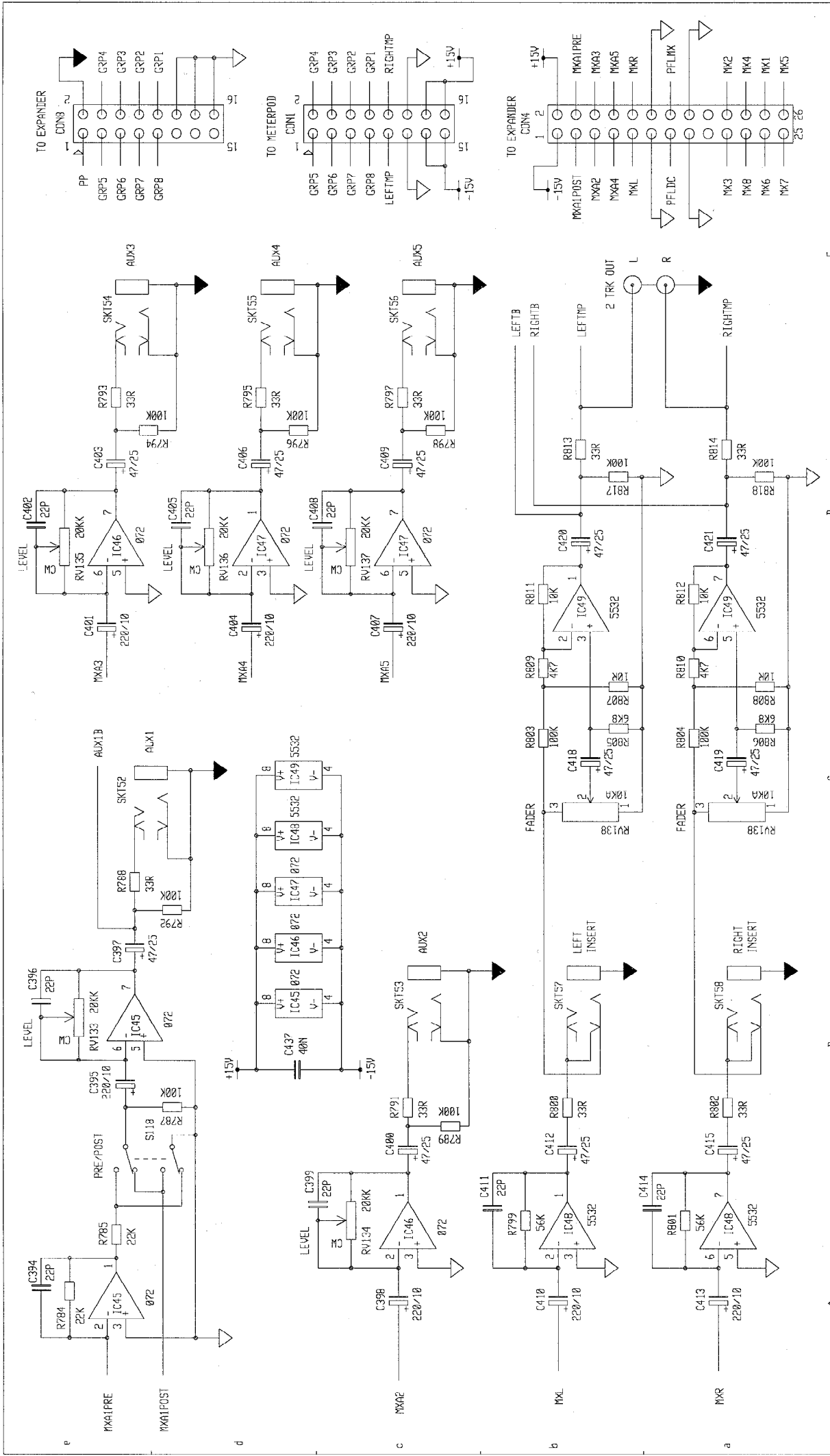

ISS.	REVISION	BY	DATE	UNIT TITLE	SHT 5 OF 8	MANUFACTURED IN ENGLAND BY
1	ORIGIN		29/3/95	DRAWING TITLE		ALLEN & HEATH
2	UPDATES	ILP	2/5/95	GSI MAIN OUTPUTS		

NOTES	
1.	RESISTORS MARKED * ARE 1% ALL OTHERS ARE 5% 1/4W UNLESS OTHERWISE MARKED
2.	ELECTROLYTIC CAPACITORS ARE µF/VOLTS

DRAWING No. C2018	ISSUE 2
-------------------	---------



ISS.		REV. NO.	DATE	BY	DATE	REV. NO.	DATE	BY	DATE	UNIT TITLE	MANUFACTURED IN ENGLAND BY
1	ORIGIN		29/3/95	ILP		SHT 6 OF 8				DRAWING TITLE	ALLEN & HEATH
2	UPDATES		2/5/95	ILP		GS1 METERS AND				MCNITOR OUTPUTS	
NOTES 1. RESISTORS MARKED * ARE 1% ALL OTHERS ARE 5% 1/4W UNLESS OTHERWISE MARKED 2. ELECTROLYTIC CAPACITORS ARE $\mu$ F/VOLTS											
DRAWING No. C2018											
ISSUE 2											
A3											

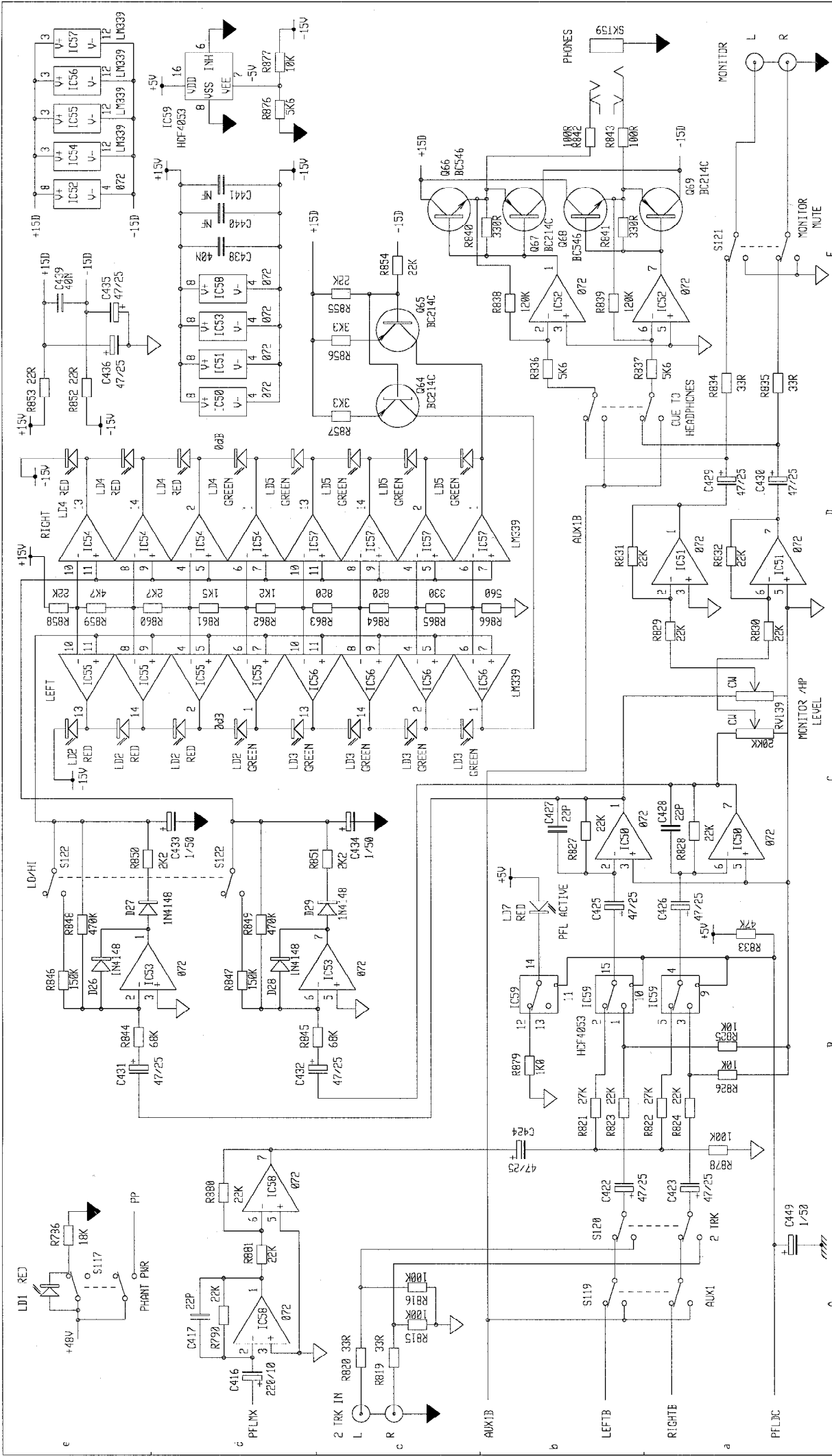

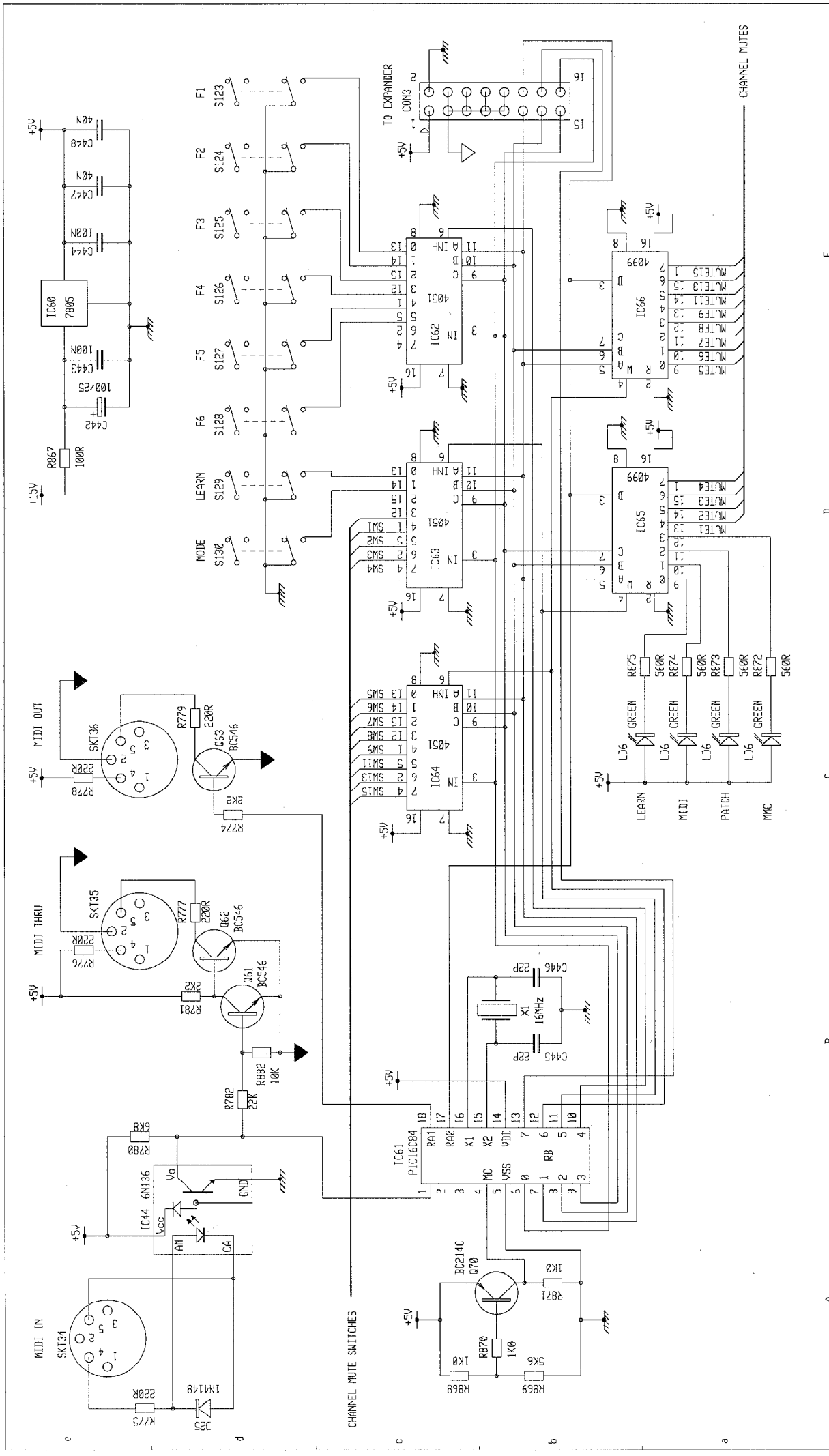
ISS.	1	REVISION	BY	DATE	NOTES	UNIT TITLE	SHT 7 OF 8	MANUFACTURED IN ENGLAND BY	E
	2	ORIGIN UPDATES	ILP	2/3/95					
					1. RESISTORS MARKED * ARE 1% UNLESS OTHERWISE MARKED	SSI MIDI	DRAWING No. C2018	ISSUE 2	A3
					2. ELECTROLYTIC CAPACITORS ARE µF/VOLTS				

ALLEN & HEATH

DRAWING No. C2018

ISSUE 2

A3

# GS1 EXPANDER CIRCUIT DIAGRAM PCB KEY & LINK OPTION POSITIONS

The areas outlined on the PCB correspond to the sheet number on the circuit diagram C2054. For a detailed PCB component ident refer to the Expander PCB component layout on the following page

## Phantom Power link options

(PP or +48V)  
( 8 off)

## Sheet no:

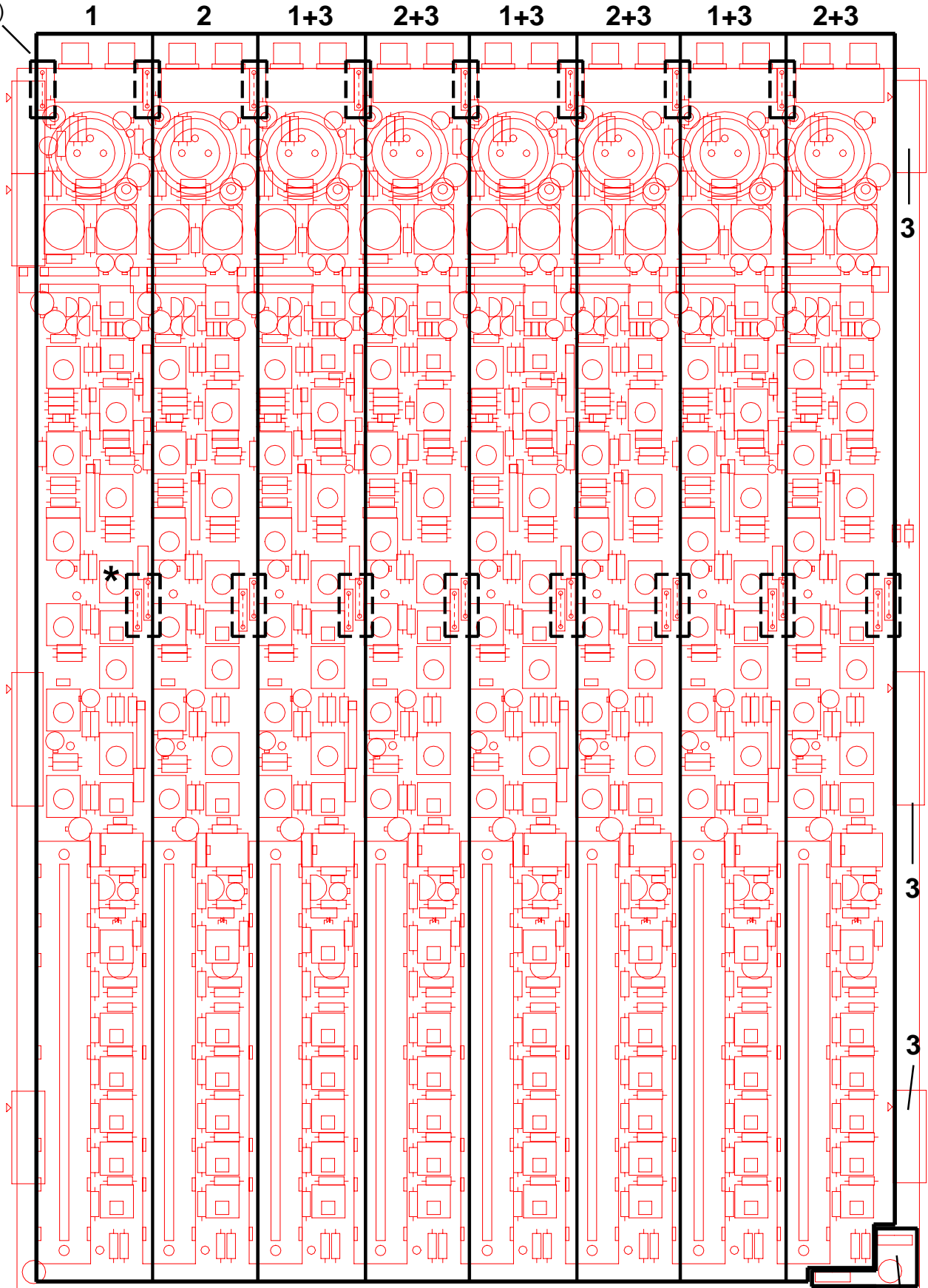

\* **Aux 1 link options:**  
Tape Return or Channel pre-fade  
( 8 pairs)

# EXPANDER PCB COMPONENT LAYOUT

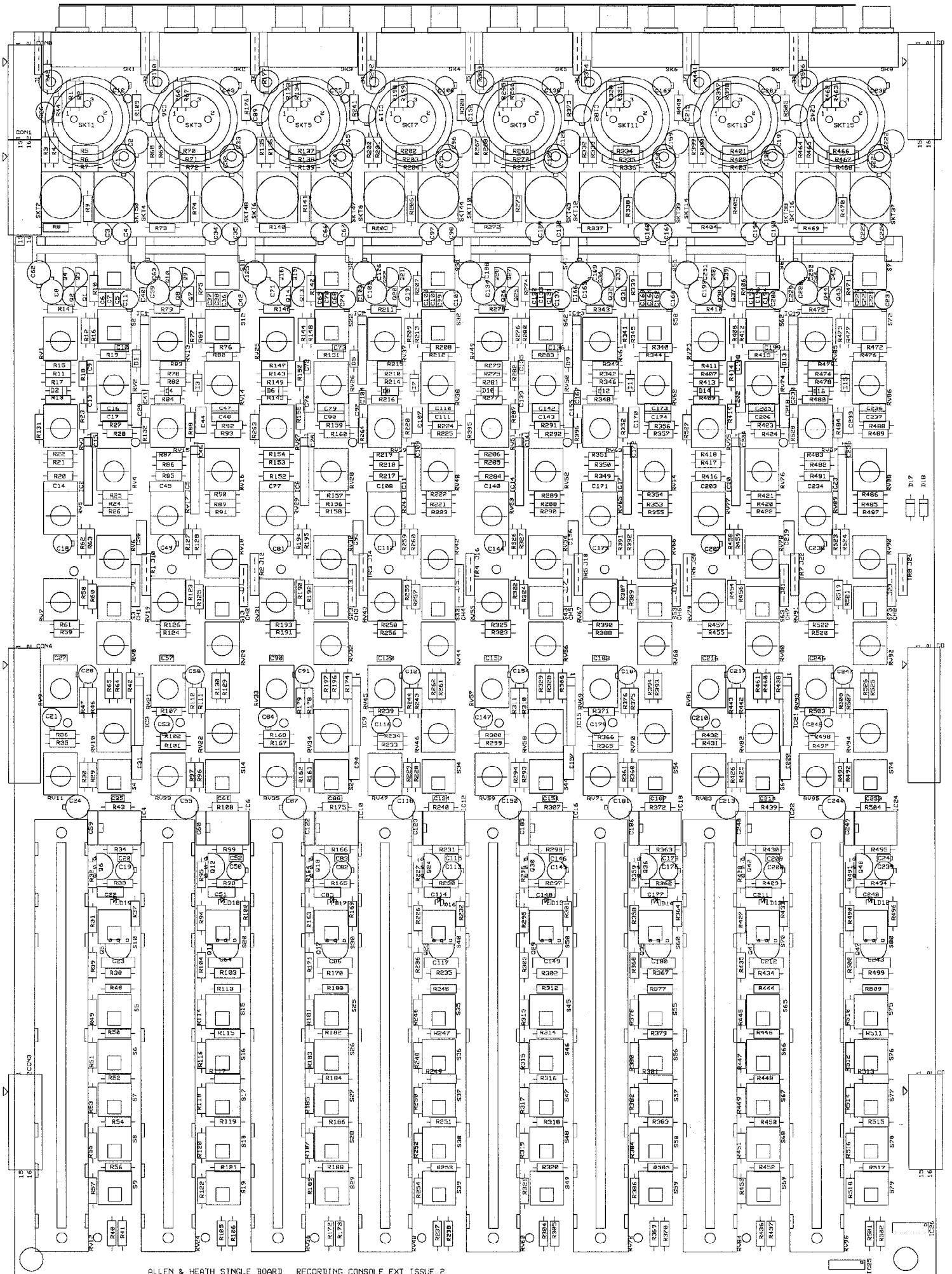



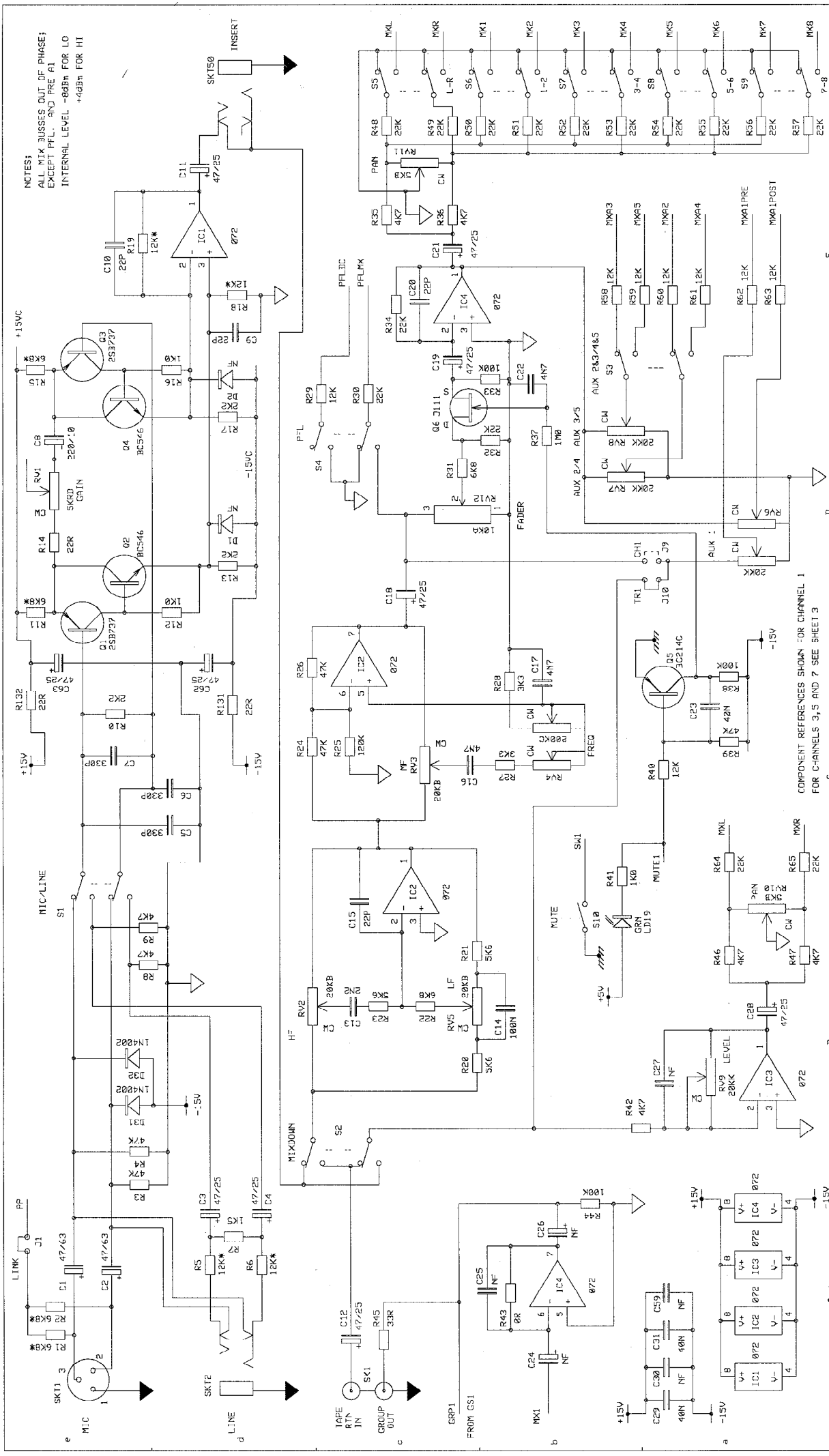

NOTES:  
 ALL MIX BUSSSES OUT OF PHASE;  
 EXCEPT PFL, AND PRE A1  
 INTERNAL LEVEL -80dB FOR LO  
 +40dB FOR HI

ISS. 1 2	REVISION	BY DATE	UNIT TITLE SHT 1 OF 3	DRAWING TITLE CS1 EXPANDER INPUT CIRCUIT CDD CHANNELS 1,3,5 AND 7	DRAWING No. C2054	ISSUE 2	A3
	ORIGIN UPDATES	DLP 29/3/95 DLP 2/5/95					
MANUFACTURED IN ENGLAND BY <b>ALLEN &amp; HEATH</b>							
COMPONENT REFERENCES SHOWN FOR CHANNEL 1 FOR CHANNELS 3,5 AND 7 SEE SHEET 3							
NOTES 1. RESISTORS MARKED * ARE 1% ALL OTHERS ARE 5% 1/4W UNLESS OTHERWISE MARKED 2. ELECTROLYTIC CAPACITORS ARE µF/VOLTS							

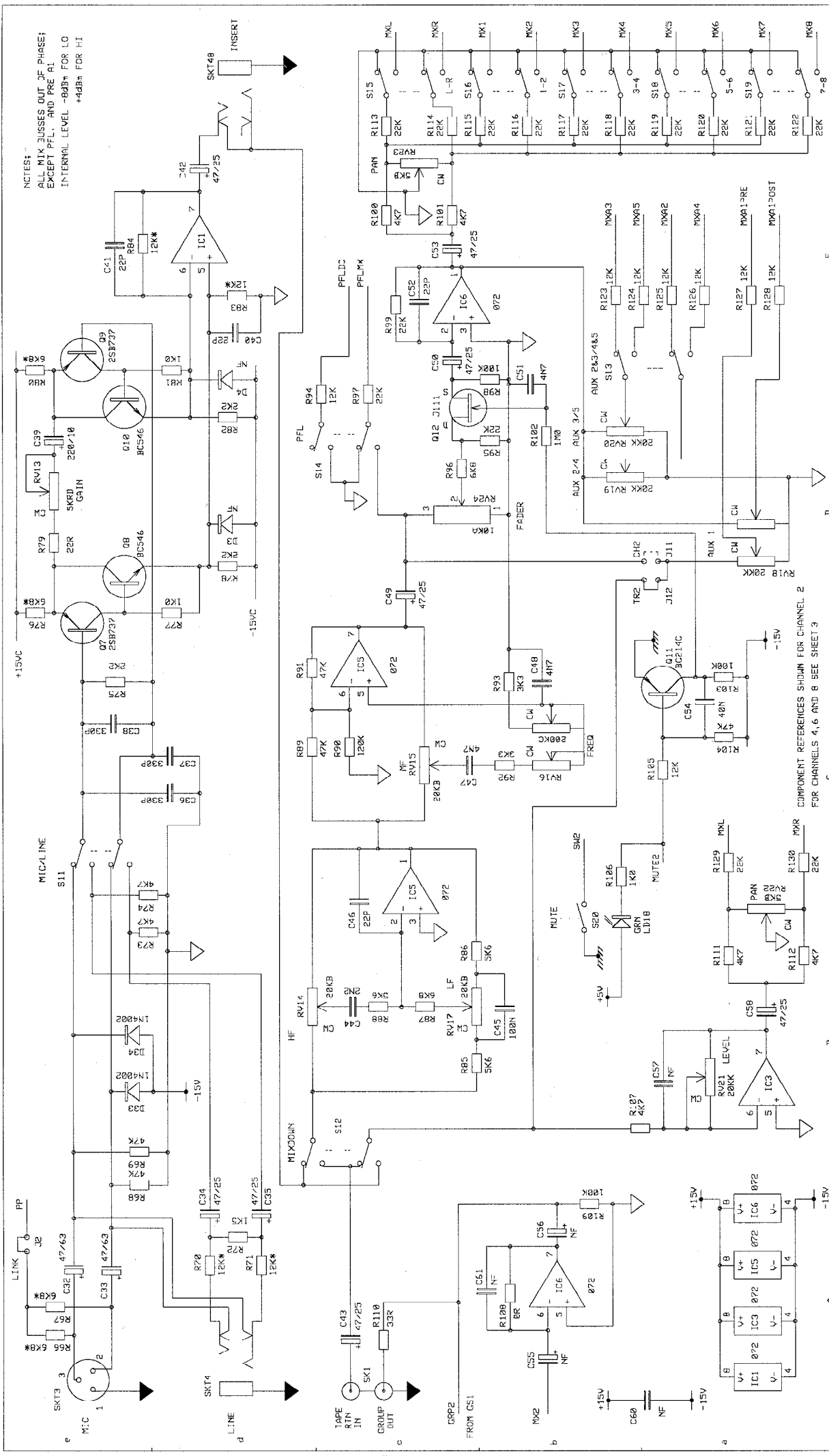

ISS.		REVISION		BY DATE	
1		DLP	29/3/95		
2		DLP	2/5/95		
ORIGIN UPDATES		UNIT TITLE SHT 2 OF 3			
DRAWING TITLE		DRAWING No. C2054			
CS1 EXPANDER INPUT CIRCUIT		ISSUE 2			
EVEN CHANNELS 2, 4, 6 AND 8		DRAWING No. C2054			
NOTES		MANUFACTURED IN ENGLAND BY ALLEN & HEATH			
1. RESISTORS MARKED * ARE 1% ALL OTHERS ARE 5% 1/4W UNLESS OTHERWISE MARKED		COMPONENT REFERENCES SHOWN FOR CHANNEL 2 FOR CHANNELS 4, 6 AND 8 SEE SHEET 3			
2. ELECTROLYTIC CAPACITORS ARE µF/VOLTS					

PREFIX	ODD CHANNELS			EVEN CHANNELS		
	CH3	CH5	CH7	CH4	CH6	CH8
C	+63	+126	+189	+63	+126	+189
D	+4	+8	+12	+4	+8	+12
IC	+6	+12	+18	+6	+12	+18
LD	-2	-4	-6	-2	-4	-6
Q	+12	+24	+36	+12	+24	+36
R	+132	+264	+396	+132	+264	+396
RV	+24	+48	+72	+24	+48	+72
S	+20	+40	+60	+20	+40	+60
SK	+2	+4	+6	+2	+4	+6
SKT	+4	+8	+12	+4	+8	+12

TO TRANSLATE COMPONENT REFERENCE NUMBERS FROM THE RELEVANT CIRCUIT DIAGRAM - ADD OR SUBTRACT THE APPROPRIATE NUMBER SHOWN IN THE TABLE ABOVE FOR EXAMPLE IC1 ON CHANNEL 1 (ODD CHANNEL CIRCUIT DIAGRAM) BECOMES IC19 ON CHANNEL 7

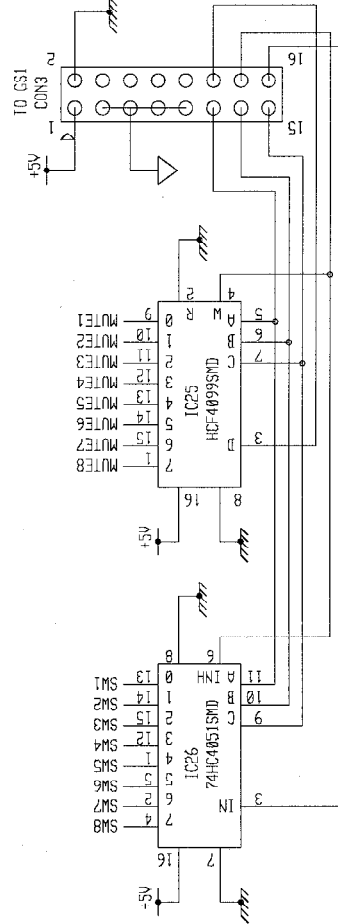
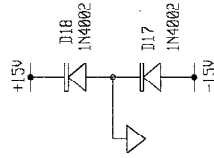
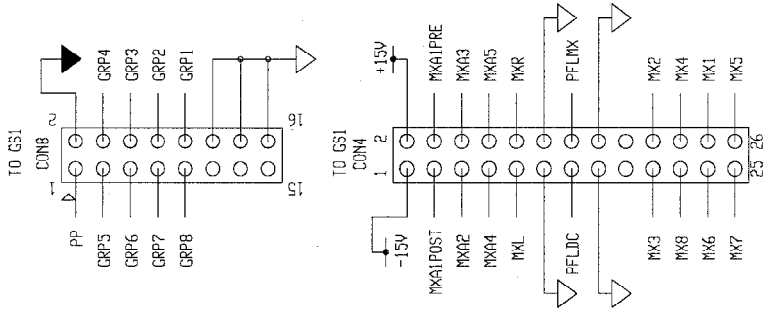

UNIT TITLE SHT 3 OF 3  
DRAWING TITLE  
GS1 EXPANDER LOGIC AND  
TRANSLATION TABLES

NOTES  
1. RESISTORS MARKED \* ARE 1%  
ALL OTHERS ARE 5% 1/4W UNLESS  
OTHERWISE MARKED  
2. ELECTROLYTIC CAPACITORS ARE  
µF/VOLTS

MANUFACTURED IN ENGLAND BY  
**ALLEN & HEATH**

ISS. 1  
2  
REVISION BY DATE  
ORIGIN ILP 29/3/95  
UPDATES ILP 2/5/95

DRAWING No. C2054  
ISSUE 2  
A3

# METERBRIDGE PCB COMPONENT LAYOUT

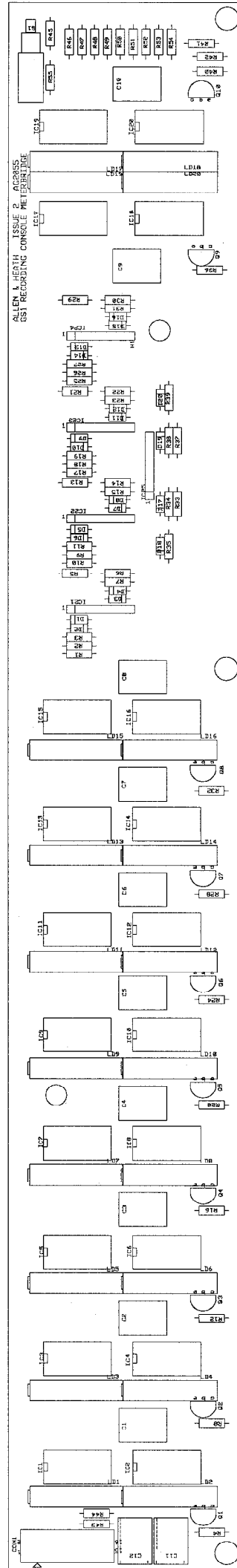

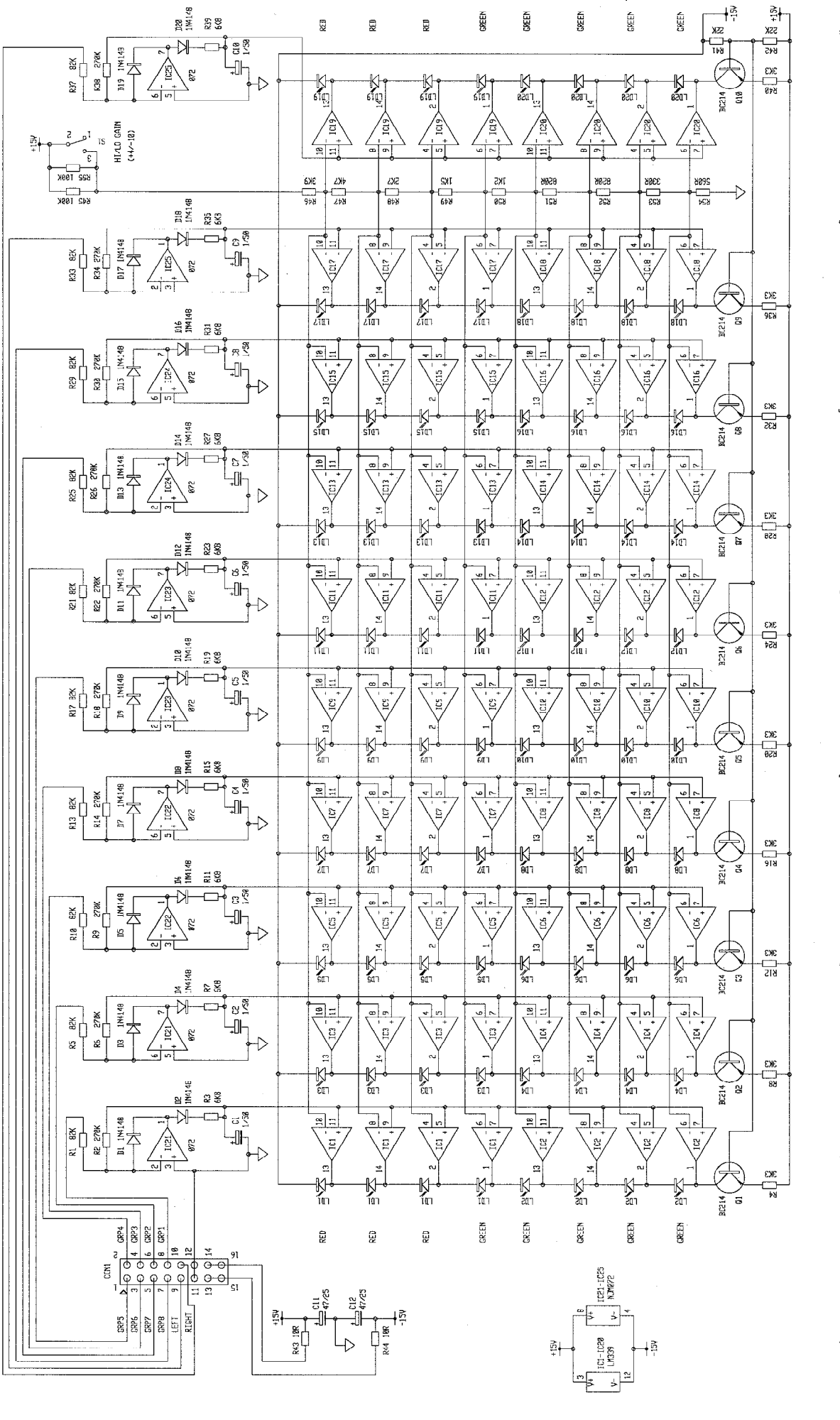

MANUFACTURED IN ENGLAND BY

UNIT TITLE  
GSI METERPOD

NOTES

BY DATE

ISS. REVISION

SHT 1 OF 1

1. REVISIONS MARKED # ARE 1X  
ALL OTHERS ARE SX 1/4X UNLESS OTHERWISE MARKED

DLP 29/3/95

ORIGIN

DRAWING TITLE

2. ELECTROLYTIC CAPACITORS ARE MFADULTS

CIRCUIT DIAGRAM

ALLEN & HEATH

DRAWING No. C2055

ISSUE 1

A2