

**ML  
3000**

**ALLEN & HEATH**



**Dual Function Live Sound Console**

# **SERVICE MANUAL**

Publication AP4511

# Introduction

This service manual provides technical information on the Allen & Heath **ML3000** audio console. Included is the technical specification, system block diagram, circuit schematics with board layouts, and a spare parts list. Information on the power supply is available in a separate publication. Only technically qualified service personnel should carry out service work on the console and its power supply.

Whilst we believe the information in this manual to be reliable we do not assume responsibility for inaccuracies. We also reserve the right to make changes in the interest of further product development.

We are able to offer further product support through our world-wide network of approved dealers and service agents. You can also access our Web site on the Internet for information on our product range and further technical support. To help us provide the most efficient service please keep a record of the console serial number, and date and place of purchase to be quoted in any communication regarding this product. The serial number is located on the rear panel.

Check out our home site for information on the company and its pedigree, our full product range and our design philosophy. We also have a site dedicated to the **ML Series** consoles.

[www.allen-heath.com](http://www.allen-heath.com)

[www.mlseries.com](http://www.mlseries.com)

## ML3000 Service Manual AP4511 Issue 1

Copyright © 2002 Allen & Heath. All rights reserved



This product complies with the European Electromagnetic Compatibility directives 89/336/EEC & 92/31/EEC and the European Low Voltage Directives 73/23/EEC & 93/68/EEC.

This product has been tested to EN55103 Parts 1 & 2 1996 for use in Environments E1, E2, E3, and E4 to demonstrate compliance with the protection requirements in the European EMC directive 89/336/EEC. During some tests the specified performance figures of the product were affected. This is considered permissible and the product has been passed as acceptable for its intended use.

Allen & Heath has a strict policy of ensuring all products are tested to the latest safety and EMC standards. Customers requiring more information about EMC and safety issues can contact Allen & Heath.

**NOTE:** Any changes or modifications to the console not approved by Allen & Heath could void the compliance of the console and therefore the users authority to operate it.

# ALLEN&HEATH

Manufactured in the United Kingdom by Allen & Heath

Kernick Industrial Estate, Penryn, Cornwall, TR10 9LU, UK

<http://www.allen-heath.com>

# Contents

---

Important Safety Instructions .....	4
Mains Plug Wiring Instructions.....	5
General Precautions .....	5
<b>ML3000</b> Key Features.....	6
Front Panel Layout.....	7
Rear Panel Layouts.....	8
Technical Specifications.....	9
System Block Diagram.....	10-11
Installation Details .....	12
Earthing .....	13
Audio Connector Types and Wiring .....	14
Gain Structure .....	15
MIDI.....	16-18
Console Computer and Operating Software ...	19
Internal Option Links .....	20
Internal assembly assignments.....	20
The Range .....	21
Ordering an Assembly.....	22-23
Ordering a Spares Kit.....	24-27
SYS-LINK fitting instructions .....	(1-4)

<b>TECHNICAL DRAWINGS .....</b>	
BLOCK DIAGRAM.....	M1
MONO INPUT .....	D1-D3
STEREO INPUT .....	D4-D7
MASTER CONNECTOR.....	D8-D10
GROUP / AUX .....	D11-D13
AUX MATRIX .....	D14-D16
MASTER DISTRIBUTION .....	D17-D18
SYSLINK INPUT .....	D19-D20
MIDI POWER.....	D21-D22
CPU .....	D23-D26
LCR SLAVE .....	D27-D29
MASTER FADER.....	D30-D33
MASTER.....	D34-D37
MONO FADER.....	D38-D40
MONO CONNECTOR.....	D41-D42
SYSLINK OUTPUT .....	D43-D44
METER MASTER .....	D45-D47
METER 1-8 & 9-16 V2.....	D48-D50
METER LEDBAR.....	D51

# Important Safety Instructions

**WARNINGS - Read the following before proceeding :**



**ATTENTION: RISQUE DE CHOC ELECTRIQUE – NE PAS OUVRIR**

- Read instructions:** Retain these safety and operating instructions for future reference. Adhere to all warnings printed here and on the console power unit. Follow the operating instructions printed in this user guide and the power unit user guide.
- Do not remove covers:** Operate the power unit with its covers correctly fitted. Refer any service work to competent technical personnel only.
- Power sources:** Connect the power unit to a mains power only of the type described in this User Guide and marked on the rear panel. Use the power cord with sealed mains plug appropriate for your local mains supply as provided with the console. If the provided plug does not fit into your outlet consult your service agent for assistance.
- Power cord routing:** Route the power cord so that it is not likely to be walked on, stretched or pinched by items placed upon or against it.
- Grounding:** Do not defeat the grounding and polarisation means of the power cord plug. Do not remove or tamper with the ground connection in the power cord.



**WARNING: This equipment must be earthed.**

- Water and moisture:** To reduce the risk of fire or electric shock do not expose the power unit or console to rain or moisture or use it in damp or wet conditions. Do not place containers of liquids on it which might spill into any openings.
- Ventilation:** Do not obstruct the ventilation slots or position the console or power unit where the air flow required for ventilation is impeded. If the console is to be operated in a flightcase ensure that it is constructed to allow adequate ventilation.
- Heat and vibration:** Do not locate the power unit in a place subject to excessive heat or direct sunlight as this could be a fire hazard. Locate the console and its power unit away from any equipment which produces heat or causes excessive vibration.
- Servicing:** Switch off the equipment and unplug the power cord immediately if it is exposed to moisture, spilled liquid, objects fallen into the openings, the power cord or plug become damaged, during lightening storms, or if smoke, odour or noise is noticed. Refer servicing to qualified technical personnel only.
- Installation:** Install the console in accordance with the instructions printed in this User Guide. Do not connect the output of power amplifiers directly to the console. Use audio connectors and plugs only for their intended purpose.



## Important Mains Plug Wiring Instructions.

The power unit is supplied with a moulded mains plug fitted to the AC mains power lead. Follow the instructions below if the mains plug has to be replaced.

The mains lead wires are coloured in accordance with the following code:

TERMINAL		WIRE COLOUR	
		European	USA/Canada
L	LIVE	BROWN	BLACK
N	NEUTRAL	BLUE	WHITE
E	EARTH GND	GREEN & YELLOW	GREEN

The wire which is coloured Green and Yellow must be connected to the terminal in the plug which is marked with the letter E or with the Earth symbol. **This appliance must be earthed.**

The wire which is coloured Blue must be connected to the terminal in the plug which is marked with the letter N.

The wire which is coloured Brown must be connected to the terminal in the plug which is marked with the letter L.

Ensure that these colour codes are followed carefully in the event of the plug being changed.

## General Precautions

---

- Damage :** To prevent damage to the controls and cosmetics avoid placing heavy objects on the control surface, scratching the surface with sharp objects, or subjecting the console to rough handling and vibration.
- Environment :** Protect from excessive dirt, dust, heat and vibration when operating and storing. Avoid tobacco ash, smoke, drinks spillage, and exposure to rain and moisture. If the console becomes wet, switch off and remove mains power immediately. Allow to dry out thoroughly before using again.
- Radiation :** To avoid induced noise and interference pickup do not operate the console close to strong sources of electromagnetic radiation such as power supplies, video monitors, lighting cables and dimmers.
- Cleaning :** Avoid the use of chemicals, abrasives or solvents. The control panel is best cleaned with a soft brush and dry lint-free cloth. Stubborn marks can be removed using a cloth dampened with isopropyl alcohol. Do not leave marking tape stuck to the console for long periods of time as the adhesive can degrade and leave a sticky residue. The faders, switches and potentiometers are lubricated for life. The use of electrical lubricants on these parts is not recommended. Refer to the power unit user guide for instructions on cleaning its ventilation filters.
- Transporting :** The console should be transported in the original packing or purpose built foam lined flightcase. Protect the control surface from damage during transit. The console is a large and heavy item. To avoid injury ensure adequate man power and precaution when lifting or moving the console.

# ML3000 Key Features

---

The Allen & Heath **ML3000** is a small footprint, affordable VCA equipped dual function live sound console providing many of the features of its larger brothers the **ML4000** and **ML5000**. It can be quickly configured for front-of-house (FOH) or stage monitor mixing. As one console suitable for both applications it is equally well suited to installation, rental and touring. It offers an IO capability and feature set that satisfies the latest requirements of live sound engineering, in particular the growing number of inputs and outputs for multi-speaker house and monitor systems, demands of stereo in-ear monitoring, 3 speaker LCR imaging, advanced grouping and automation. The design ensures on-the-road durability, a clear layout for easy walk up and go operation, and no-compromise audio performance.

## Inputs and Outputs

---

- 3 Standard frame sizes: 24+2, 32+2, 40+2 (mono + dual stereo channels)
- 24, 32, 40 mono mic/line inputs with inserts and direct outputs
- 2 dual stereo line inputs
- Sys-Link option to link consoles for more channels
- Main Left, Right and Centre outputs with inserts, Centre configurable as the engineers monitor
- 4 Groups, 8 Auxes: Group/Aux 1-4 and Aux 5-8 with faders and inserts, Aux 1-4 with rotaries
- Aux 7/8 configurable as mono or stereo with level and pan controls
- 8x4 Matrix
- 2-Track monitor input and recording send
- Stereo headphones and local monitors
- Talkback mic input
- Talkback/Oscillator output

## Groups and Automation

---

- 8 VCA groups with mutes
- 4 audio groups with LCRplus™ sub grouping
- 8 mute groups
- MIDI accessible snapshot memories
- MIDI mute on/off, snapshot recall and dump in/out control

## Processing and Control

---

- 4-Band 2 sweep mono EQ, 4-band fixed frequency stereo EQ
- Sweepable high pass filter
- LCRplus™ 3 speaker imaging system
- Protected mode switching to configure the console for FOH or monitor application
- PFL override AFL override selected monitor source
- Assignable talkback
- 1kHz tone and pink noise generator for system line-up and testing
- Full console monitoring and extensive metering with LED bars and illuminated VU

# Front Panel Layout

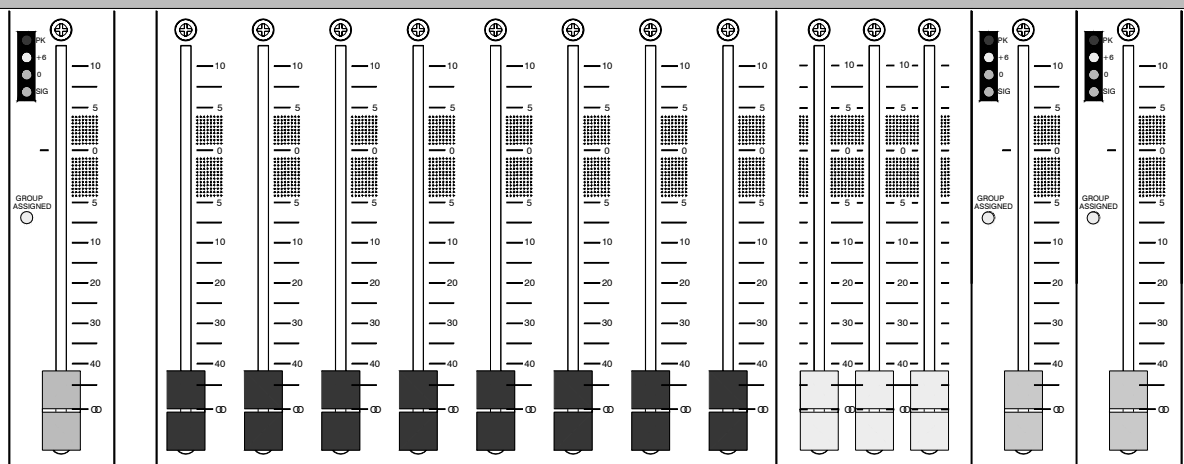
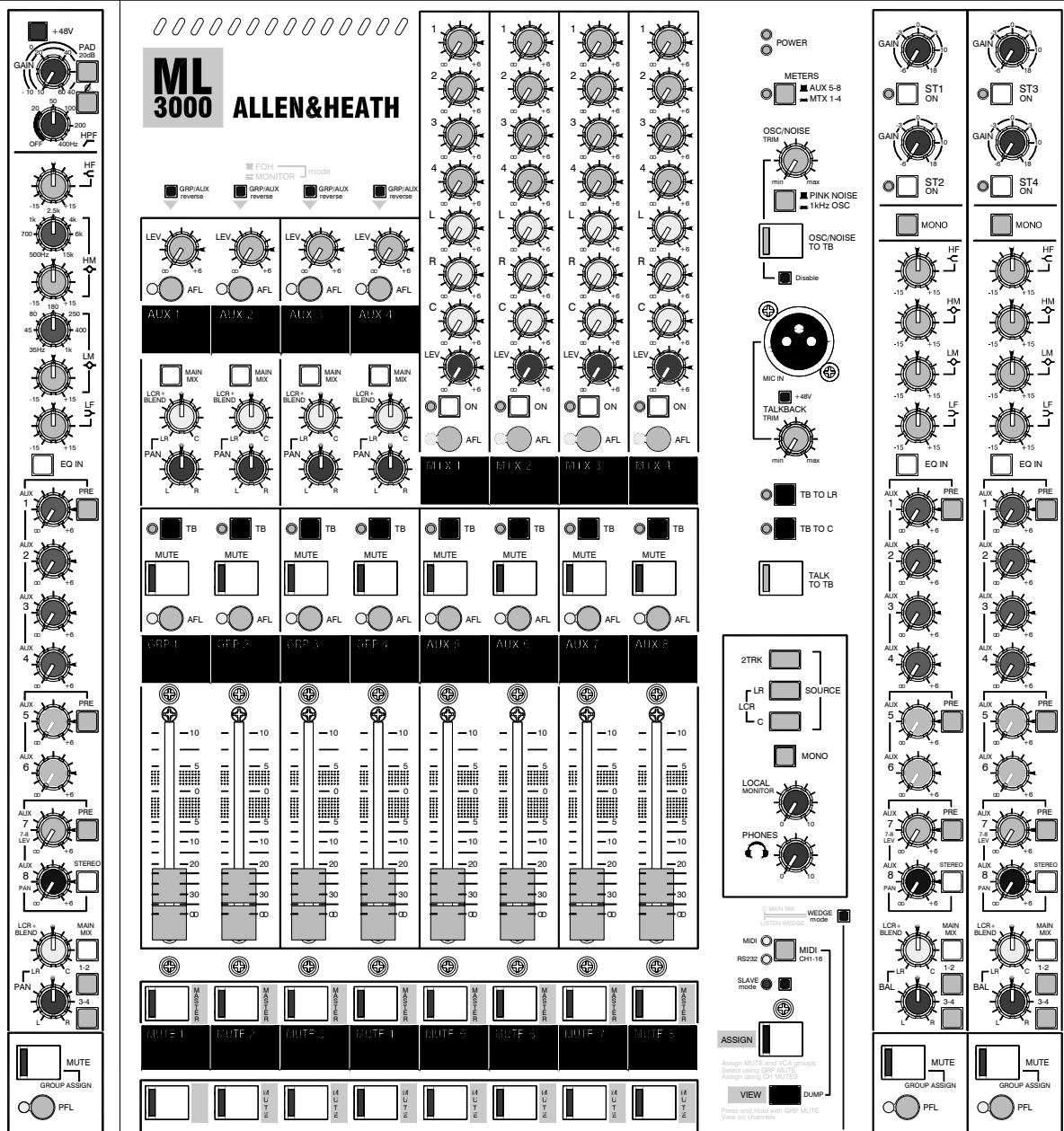

# Rear Panel Layouts

**Meterpod** Gooseneck lamp connectors.

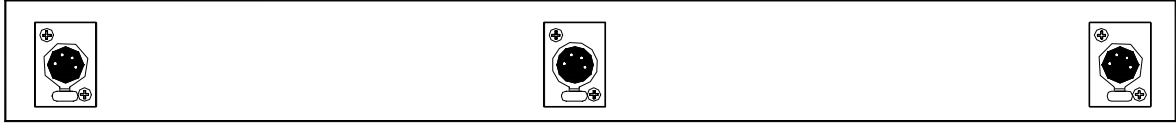

**Console** Audio, expander, intercom, power, MIDI and logic connectors.

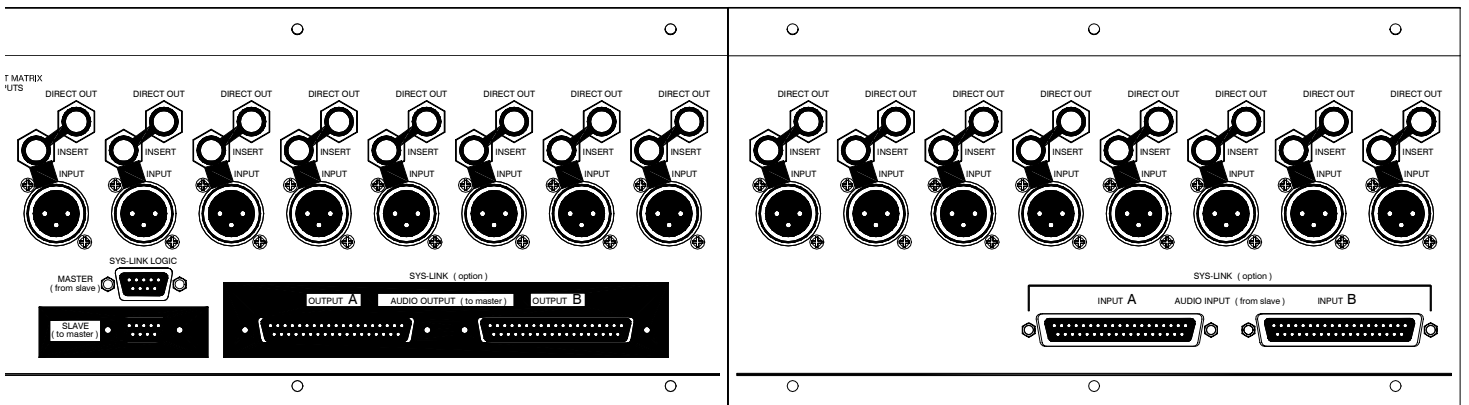
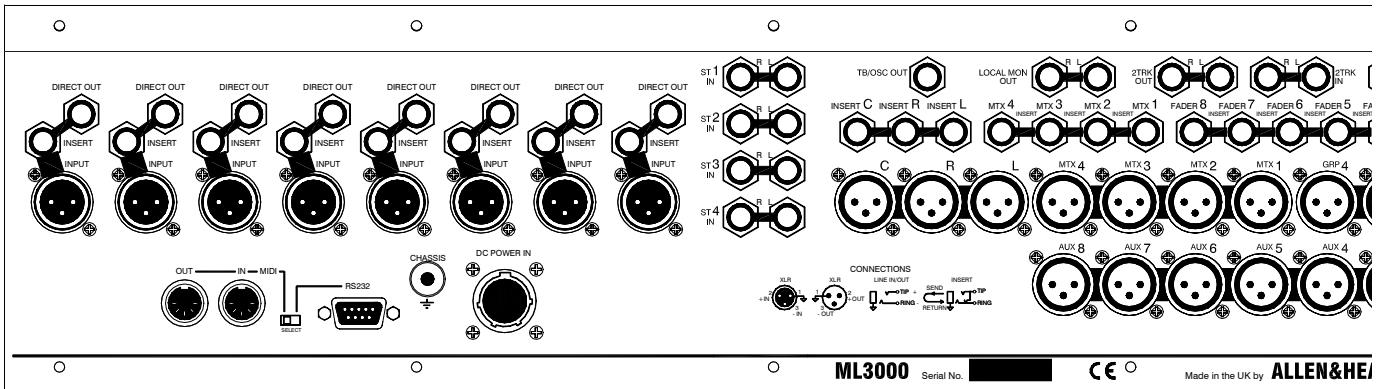



# Technical Specifications

0dBu = 0.775 Vrms, +4dBu = 1.23 Vrms

## Operating Levels

Channels ..... 0dBu Headroom +21dB  
Mix ..... -2dBu Headroom +23dB  
Max XLR output ..... +23dBu

## Frequency Response Referred to 1kHz at +4dBu

Mic to main output (+40dB) ..... 20Hz to 70kHz +0/-0.5dB  
Line to main output (0dB) ..... 20Hz to 22kHz +0/-0.5dB

## Distortion @1kHz 0dBu

THD+noise ..... < 0.01%

## CMRR Common mode rejection @1kHz

Mic (+40dB) ..... > 85dB  
Mic + Pad (0dB) ..... > 50dB

## Crosstalk Referred to driven channel @1kHz

Channel to channel ..... < -95dB  
Mute shutoff ..... < -85dB  
Fader shutoff ..... < -85dB

## Noise Performance Measured rms 22Hz to 22kHz unweighted

Mic EIN with 150 ohm source ..... -128dB  
Residual output noise ..... < -98dBu  
Mix noise, nothing routed ..... < -95dBu  
Mix noise, 24 channels routed ..... < -88dBu

## Metering

Reading 0 ..... 0dBu at XLR outputs  
LED meters ..... Peak reading, 3 colours  
VU meters ..... Ave reading, illuminated moving coil  
Peak indicators ..... 5dB before clip, multi-point sensing  
Input meters ..... 4 bar LED (signal, 0, +6, peak)  
Group/Mtx meters ..... VU  
L,R,C meters ..... VU and 16 bar LED

## Lamp Connectors x3

Connector ..... XLR-F 4pin  
Rating ..... 12V 400mA max

## Channel Filters

Slope ..... 12dB/oct high pass  
Frequency ..... Off to 400Hz

## Mono Equaliser

HF ..... +/-15dB, 12kHz shelf  
HM ..... +/-15dB, 500Hz to 15kHz bell Q=1.9  
LM ..... +/-15dB, 35Hz to 1kHz bell Q=1.9  
LF ..... +/-15dB, 60Hz shelf

## Stereo Equaliser

HF ..... +/-15dB, 12kHz shelf  
HM ..... +/-15dB, 2.5kHz bell Q=1.6  
LM ..... +/-15dB, 250Hz bell Q=1.6  
LF ..... +/-15dB, 60Hz shelf

## Power Supply Model RPS11

Case ..... External 3U rack or floor mount  
Type ..... Linear, convection cooled  
Mains Voltage ..... 100,120,220,230 V.AC selectable  
Mains Frequency ..... 50/60Hz  
Power consumption ..... 300W

## Dimensions

	Width	Depth	Height
24 Channel	1141 (45")	640 (25.2")	252 (9.9")
32 Channel	1396 (55")	640	252
40 Channel	1651 (65")	640	252
RPS11 psu	483 (19")	229 (9")	134 (3U)
RPSD2	483 (19")	180 (7")	45 (1U)

## Weights

24 Channel ..... 34 kg (75 lbs)  
32 Channel ..... 41 kg (90 lbs)  
40 Channel ..... 48 kg (106 lbs)  
RPS11 psu ..... 9.5 kg (21 lbs)  
RPSD2 ..... 6kg (13 lbs)

## INPUTS:

Mic (Pad out) ..... XLR ..... balanced, pin2+ ..... 2k ohm ..... variable -60 to -10dBu ..... Max +11dBu  
Mic/Line (Pad in) ..... >10k ohm ..... variable -40 to +10dBu ..... Max +31dBu  
Stereo ST1-4 ..... TRS jack ..... balanced, tip+ ..... >20k ohm ..... variable -18 to +6dBu ..... Max +27dBu  
2-Track ..... TRS jack ..... balanced, tip+ ..... >20k ohm ..... +4dBu ..... Max +25dBu  
Matrix Ext In ..... TRS jack ..... balanced, tip+ ..... >20k ohm ..... 0dBu ..... Max +21dBu

## INSERTS:

Input ..... TRS jack ..... unbalanced, tip send, ring return ..... 0dBu ..... Max +21dBu  
Output ..... TRS jack ..... unbalanced, tip send, ring return ..... -2dBu ..... Max +21dBu  
Matrix ..... TRS jack ..... unbalanced, tip send, ring return ..... -2dBu ..... Max +21dBu

## OUTPUTS:

L,R,C ..... XLR ..... balanced, pin2+ ..... <75 ohm ..... 0dBu ..... Max +23dBu  
Grp 1-4 ..... XLR ..... balanced, pin2+ ..... <75 ohm ..... 0dBu ..... Max +23dBu  
Aux 1-8 ..... XLR ..... balanced, pin2+ ..... <75 ohm ..... 0dBu ..... Max +23dBu  
Matrix 1-4 ..... XLR ..... balanced, pin2+ ..... <75 ohm ..... 0dBu ..... Max +23dBu  
Direct out ..... TRS jack ..... ground comp, tip+ ..... <50 ohm ..... 0dBu ..... Max +21dBu  
2-Track ..... TRS jack ..... ground comp, tip+ ..... <50 ohm ..... 0dBu ..... Max +21dBu  
TB/Osc out ..... TRS jack ..... imp balanced, tip+ ..... <50 ohm ..... 0dBu ..... Max +21dBu  
Local Monitor ..... TRS jack ..... imp balanced, tip+ ..... <50 ohm ..... 0dBu ..... Max +21dBu  
Headphones ..... TRS jack ..... tip left, ring right ..... for stereo headphones >30 ohms

# System Block Diagram

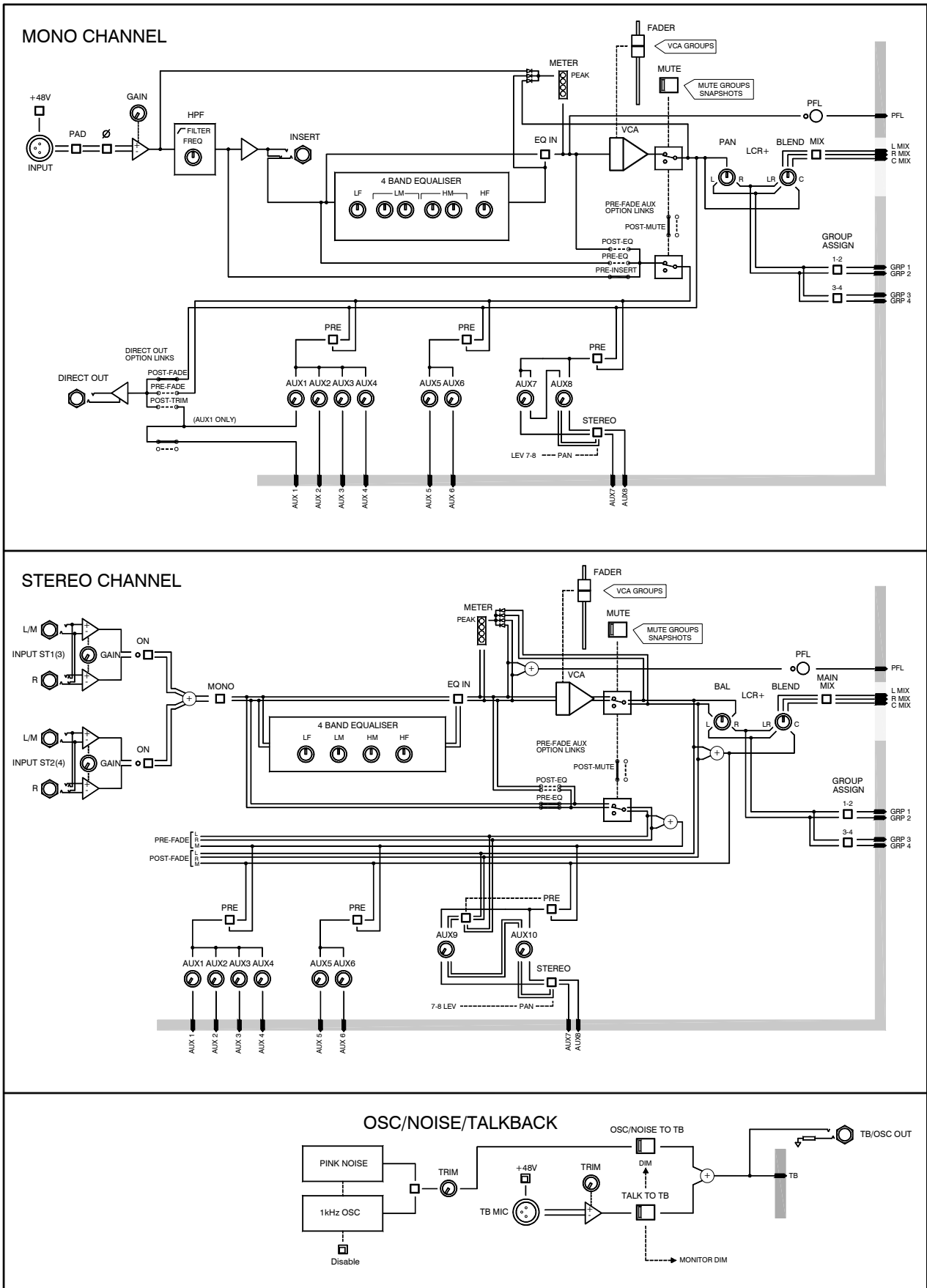

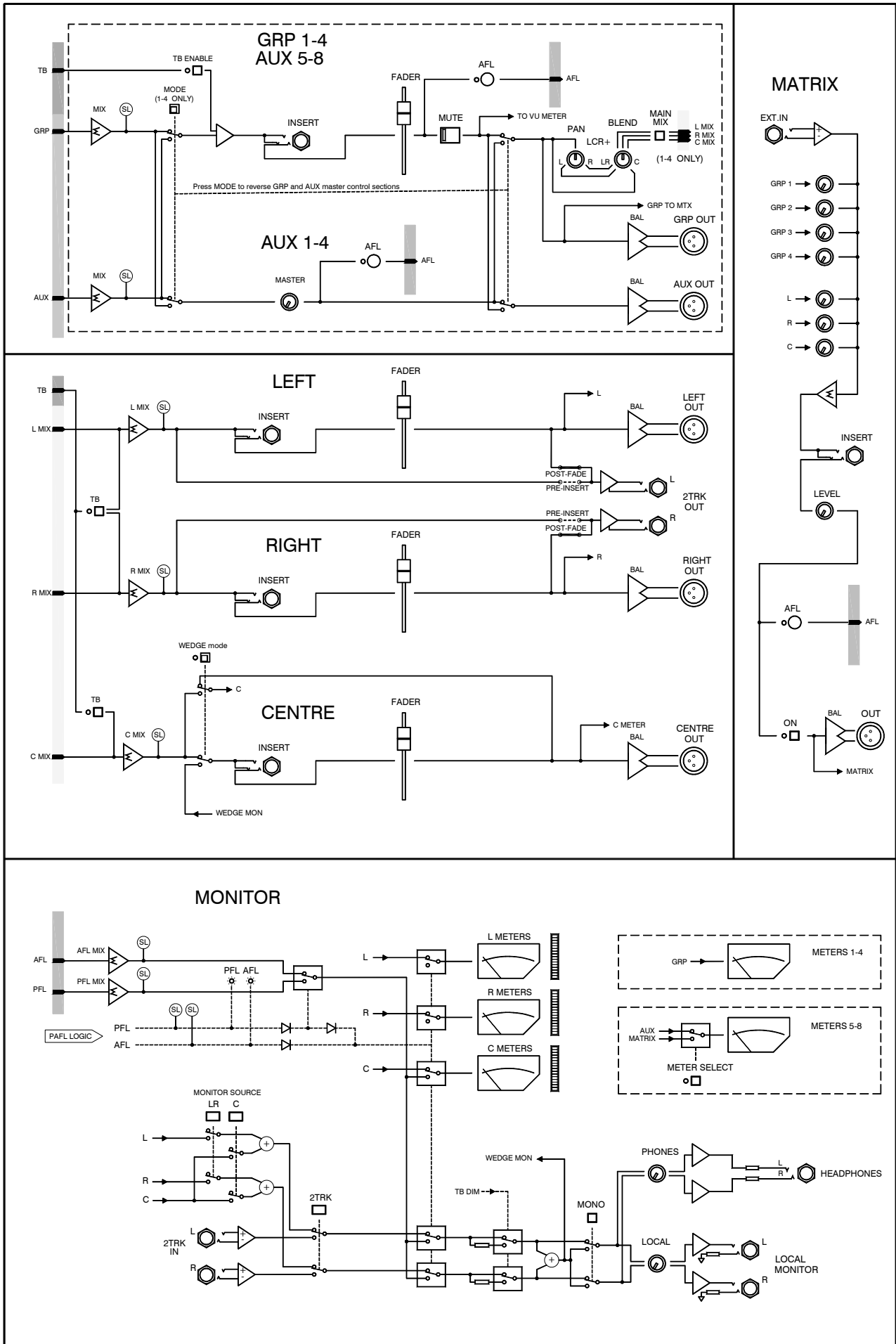

# Installation Details

Weights	24 Channel	34 kg (75 lbs)
	32 Channel	41 kg (90 lbs)
	40 Channel	48 kg (106 lbs)
	RPS11 psu	9.5 kg (21 lbs)

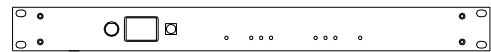
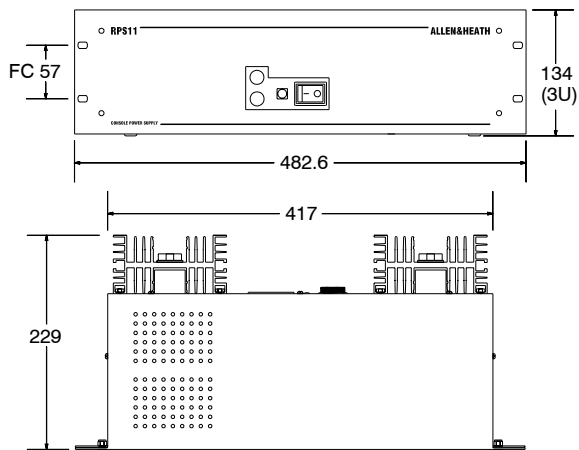
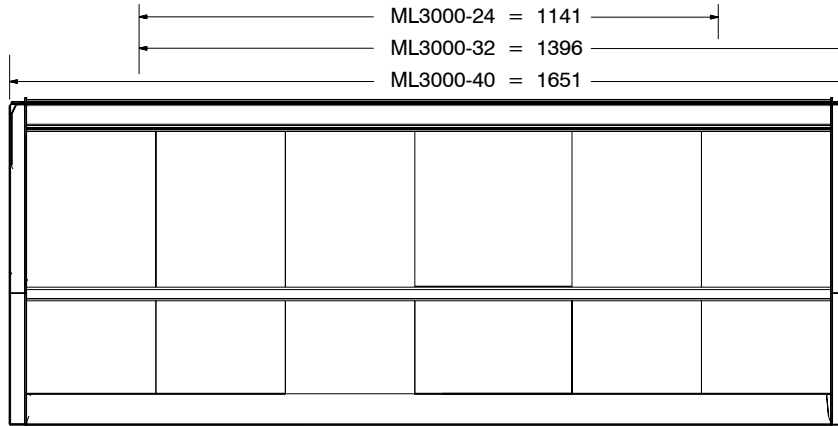
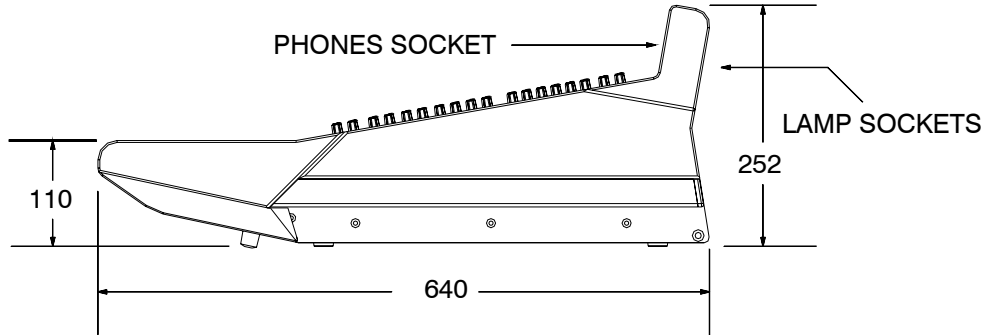

Refer to the power supply user guide for safety and installation instructions. **Heed all warnings printed in the user guide and on the power unit.**

Refer to the RPSD2 user guide for instructions on linking two RPS11 power supplies for redundant supply backup.



The connection to earth (ground) in an audio system is important for two reasons:

1. **SAFETY** - To protect the operator from high voltage shock, and
2. **AUDIO PERFORMANCE** - To minimise the effect of earth (ground) loops which result in audible hum and buzz, and to shield the audio signals from interference.

For safety it is important that all equipment earths are connected to mains earth so that exposed metal parts are prevented from carrying high voltage which can injure or even kill the operator. It is recommended that the engineer check the continuity of the safety earth from all points in the system including microphone bodies, guitar strings, connector cases, equipment panels and so on.

The same earth is also used to shield audio cables from external interference such as the hum fields associated with power transformers, lighting dimmer buzz, and computer radiation. Problems arise when the signal sees more than one path to mains earth. An earth loop results causing current to flow between the different earth paths. This condition is usually detected as a mains frequency audible hum or buzz.

To ensure safe and trouble-free operation we recommend the following:

**Use a clean mains outlet for the audio system.** Keep the audio equipment mains feed separate from that powering 'dirty' equipment such as air conditioning and lighting systems, motors and vending machines.

**Use star point earthing.** It is best to install a 'star point' system where the individual earths to the equipment racks and equipment areas are separately run from a solid central reference earth point.

**Have your mains system checked by a qualified electrician.** If the supply earthing is solid to start with you are less likely to experience problems.

**Do not remove the earth connection from the console mains plug.** The console chassis is connected to mains earth through the power cable to ensure your safety. Audio 0V is connected to the console chassis internally. If problems are encountered with earth loops operate the audio 'ground lift' switch on the power supply or connected equipment, or disconnect the cable screens at one end, usually at the destination.

**Avoid induced interference.** To prevent interference pickup keep audio cables away from mains power units, cables and distribution boards, motors, lighting and computer cables and equipment, and any other heavy duty electrical equipment. Where this cannot be avoided cross the audio and 'dirty' equipment cables at right angles to minimise interference.

**Use low impedance sources** such as microphones and line level equipment rated at 200 ohms or less to reduce susceptibility to interference. The console outputs are designed to operate at very low impedance to minimise interference problems.

**Use balanced connections where possible** as these provide further immunity by cancelling out interference that may be picked up on long cable runs. To connect an unbalanced source to a balanced console input, link the cold input (XLR pin 3 or jack ring) to 0V earth (XLR pin 1 or jack sleeve) at the console. To connect a balanced console output to an unbalanced destination, link the cold output to 0V earth at the console.

**Use good quality cables and connectors** and check for correct wiring and reliable solder joints. Allow sufficient cable loop to prevent damage through stretching.

# Audio Connector Types and Wiring

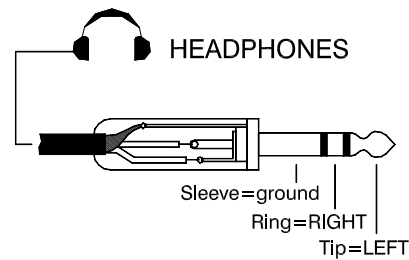
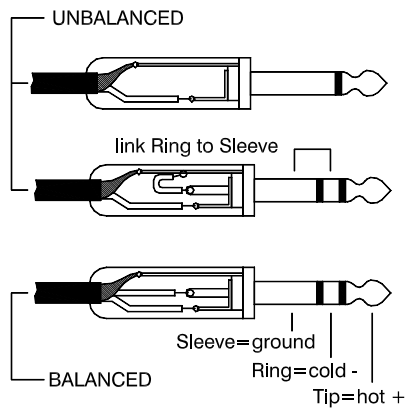
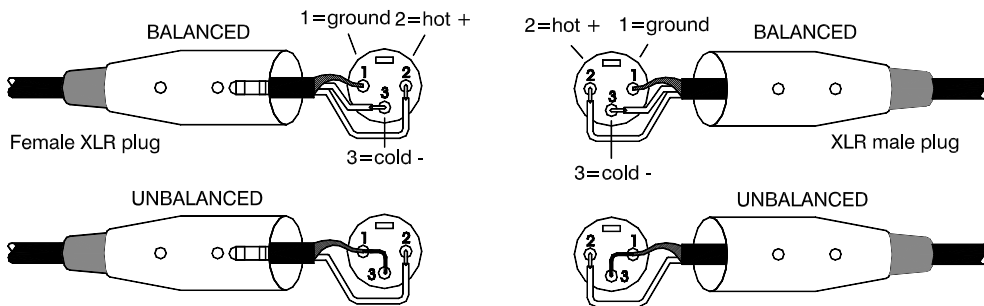
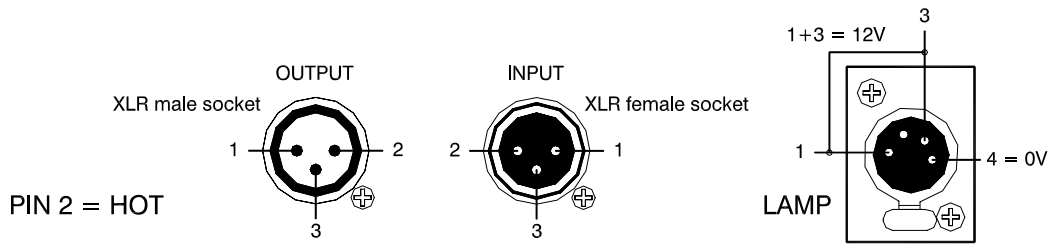
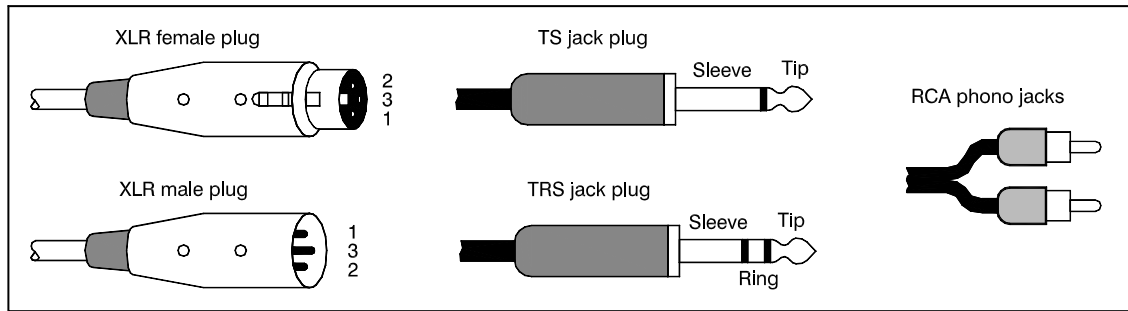

## SYS-LINK OPTION

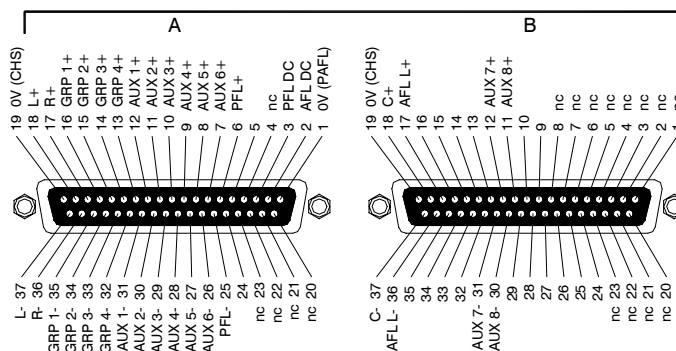

# Gain Structure

How the levels between the different signal stages are set up is referred to as the gain structure. For best performance it is important that the connected source signals are matched to the 'normal operating level' of the console. Similarly the levels of the connected amplifiers and destination equipment should be correctly matched to the console outputs. If set too high then the signal peaks will be clipped resulting in distortion, and if set too low then the signal-to-noise performance will be degraded resulting in excessive background hiss and noise.

**Using the Meters.** The **ML3000** provides metering of inputs and outputs. For best results operate the console with the LED bar meters averaging around '0' allowing the loudest moments to reach '+6'. Reduce the gain if the red peak LEDs start to flash. Note that the peak leds light 5dB before actual clipping to warn that you are nearing distortion and should reduce gain. The LED bar meters have a peak response with fast attack and slow release so that fast musical transients are accurately displayed. The VU meters have a slower attack so that the average levels are better displayed. Both types of metering are useful in live sound mixing.

**Matching a Source to the Console.** Start by turning down the channel fader and send levels to prevent unexpected loud volumes reaching the main speakers and monitors. Adjust the GAIN control for an average '0' reading on the channel meter. Press PFL to listen to the signal using headphones, local or wedge monitor, and to view its level on the main LED and VU meters. Once the gain is correctly set you can raise the levels to bring the channel into the mix. Note that you may need to adjust the gain if you make significant changes to the EQ. Make sure that any equipment inserted into the channel is set to operate around 0dBu line level. It is best to first set the gain with inserted signal processors such as compressors switched to bypass.

## Matching the Console to Destination Equipment.

The console produces a standard XLR output level of 0dBu for a meter reading of '0'. It can produce a maximum of +23dBu and is therefore well suited to driving equipment operating at nominal 0dBu or +4dBu while providing plenty of headroom. If you are connecting directly to a sensitive power amplifier it is advisable to turn down its input trim control if the normal console level is too high. Simply turning down the console output faders degrades the output stage noise performance and reduces the resolution of the fader movement. The output faders are best operated around '-10' to '0' for loudest average volume required. This allows plenty of additional headroom if you need it.

**Terminology.** The **normal operating level** is the optimum signal level for best console performance, indicated by '0' meter readings and resulting in the 0dBu output level. The channels operate at 0dBu and the mix stages at -2dBu for extended headroom. **Headroom** is the extra level available above normal to allow for loud peaks before the signal becomes **clipped** resulting in audible distortion. The **signal-to-noise ratio** (SNR) is the difference measured in dB between normal level and residual noise floor (hiss) produced by the console electronics. The **dynamic range** is the sum of headroom and SNR representing the maximum signal range possible from quietest to loudest.

**Using the VCA Groups.** Assigning a channel to one or more VCA groups lets those group faders control the level of its VCA element. Each fader provides up to +10dB boost. Note that the channel VCA allows a maximum combined fader boost of +10dB. Any more is simply ignored. It is best to operate the VCA group faders around their nominal '0' position. You can also use a VCA group to reduce the overall level of a hot mix without having to adjust all the channel faders.

**Final word...** A little care with setting gain structure throughout the signal chain will give you the very best performance and most manageable control of the mix.

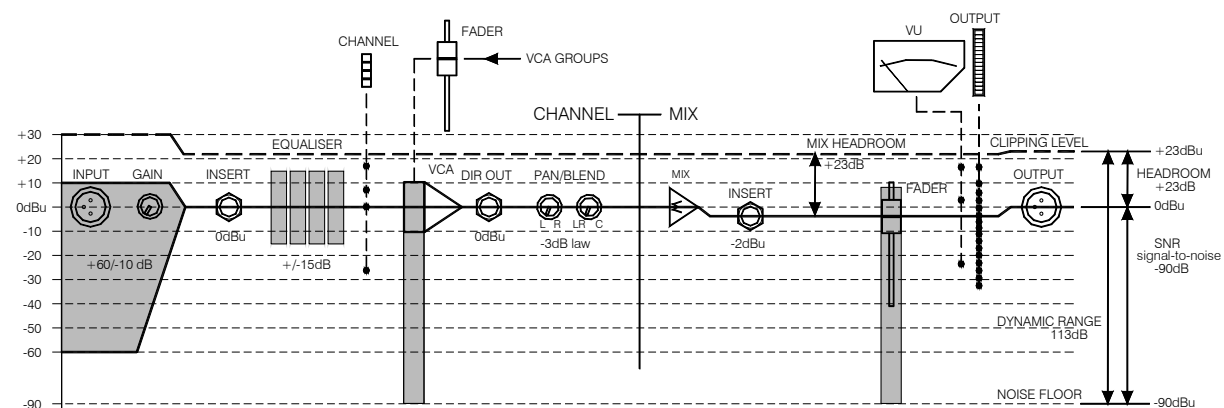

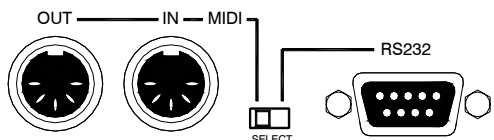
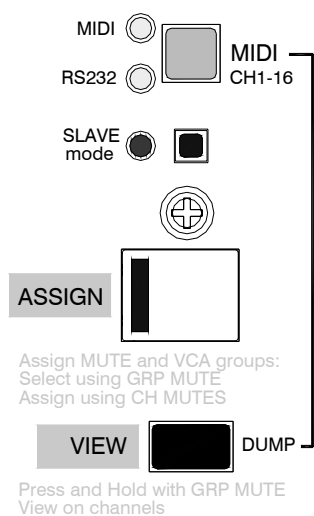

## The MIDI Cables

Use standard 5-pin 180 degree DIN type male-to-male MIDI cables. These should be available from your local audio dealer or music shop. The cables should not exceed 15 meters (50 feet) in length.

To control external equipment plug console MIDI OUT to external equipment MIDI IN. To control the console plug external equipment MIDI OUT or THRU to console MIDI in.

Make sure the same MIDI channel number is selected on the console and external equipment you want the console to communicate with.

## RS232

Set the rear panel switch to RS232 if you need to load in new console operating software or interface to a PC via its serial port. The Allen & Heath ML Archiver software provides archiver and snapshot manager functions that run on a PC.

**Note:** The console takes longer to boot after power up when the rear switch is set to RS232. This is because it interrogates the port for a code update. For normal operation the MIDI position is recommended.

## MIDI Overview

The **ML3000** includes a Musical Instrument Digital Interface (MIDI) port. Standard 5-pin IN and OUT sockets allow connection to external MIDI equipment such as computer show control systems, sequencers, instruments and data archiving devices. Applications include sophisticated 'hands-off' scene control, effects and instrument patch control, switching of signal processing remote controllers, and archiving of the console settings and memories for later re-use.

### What the console MIDI can do :

- ✓ Turn channel mutes on and off
- ✓ Store and recall snapshot memories
- ✓ Snapshot program change messages
- ✓ Archive console settings and memories

### What the console MIDI cannot do :

- ✗ Turn Mute Groups on and off
- ✗ Turn VCA group mutes on and off
- ✗ Assign channels to VCA groups
- ✗ Control VCA fader levels

The capabilities of the console automation system are subject to continual development and new features may be added in time. The latest operating software is available on the Allen & Heath Internet site together with loading instructions.

## Selecting MIDI Operation

For MIDI operation make sure the rear panel switch is set to the MIDI position. The RS232 setting is only used when updating the console operating software to a new version, or with the Allen & Heath ML3 Archiver utility for the PC.

## Changing the MIDI Channel Number

Hold down the master section MIDI CH key. The current MIDI channel number is displayed on one of the CH1 to 16 GROUP ASSIGNED LEDs next to the faders. The LED flashes to attract your attention. Simply press one of the CH1 to 16 MUTE keys while holding down MIDI CH to change the MIDI channel number. The channel mute is not affected during this operation.



HEX	MUTE
20	CH 1
21	CH 2
22	CH 3
23	CH 4
24	CH 5
25	CH 6
26	CH 7
27	CH 8
28	CH 9
29	CH 10
2A	CH 11
2B	CH 12
2C	CH 13
2D	CH 14
2E	CH 15
2F	CH 16
30	CH 17
31	CH 18
32	CH 19
33	CH 20
34	CH 21
35	CH 22
36	CH 23
37	CH 24
38	CH 25
39	CH 26
3A	CH 27
3B	CH 28
3C	CH 29
3D	CH 30
3E	CH 31
3F	CH 32
40	CH 33
41	CH 34
42	CH 35
43	CH 36
44	CH 37
45	CH 38
46	CH 39
47	CH 40
48	CH 41
49	CH 42
4A	CH 43
4B	CH 44
4C	CH 45
4D	CH 46
4E	CH 47
4F	CH 48
50	STEREO 1
51	STEREO 2

## Channel Mutes

Pressing any input or output channel MUTE switch transmits a MIDI Note On message. Similarly, receiving a MIDI Note On message will turn the associated channel mute on or off.

Console mutes are mapped to MIDI Note numbers as shown in the table. Running status is supported on receive and transmit.

**Transmit.** Pressing a channel MUTE switch transmits the following Note On messages:

9n cc vv 9n cc 00

Where n = console MIDI channel number  
cc = input or output channel number  
vv = 3FH for mute off, 7FH for mute on

**Receive.** The console responds to the following MIDI Note On message:

9n cc vv (00 is ignored)

Where vv < 40H = mute off,  
40H <= vv <= 7FH = mute on

## Snapshot Memories

Recalling a snapshot will transmit a MIDI Program Change message. Receiving a Program Change message will recall a snapshot.

Snapshot numbers 1 to 128 are mapped to MIDI Program Change numbers 0 to 127. Running status is supported on receive and transmit.

**Transmit and Receive.** The message format is:

Cn pp

Where n = console MIDI channel number  
pp = console snapshot number 00H to 7FH

## Archiving the Console Settings

The console settings can be saved to an external device such as a MIDI sequencer or data archiver using the dump out facility. Settings can be loaded back into the console using dump in. This is ideal when you want to archive the settings to use at a later date, for example a re-run of a previous performance. You can also use the dump facility to program additional **ML3000** consoles, for example when setting up duplicate shows or swapping consoles around. Simply link MIDI OUT from one to MIDI IN of the other and action the dump out facility.

### Settings which are archived :

- ✓ Current mute settings
- ✓ Current Mute group assignments
- ✓ Current VCA group assignments
- ✓ All snapshot memories

### Settings which are not archived :

- ✗ Current console operating mode

## MIDI Dump Out

Connect the console to a suitable MIDI archiving device. Set the same MIDI channel number on both. Check the rear switch is set to MIDI. Press the MIDI and VIEW keys together. The console dumps the current settings and memory contents using a SysEx message string. During this time the MIDI LED lights to show that data is being sent via the MIDI port. Note that this operation can take up to 10 seconds during which time the console mutes and assignment operations are interrupted.

## MIDI Dump In

Connect the console to the MIDI archiving device. Set the same MIDI channel number on both. Check the rear switch is set to MIDI. Start the process using the MIDI archiver. The console current settings and memory contents are overwritten. During this time the MIDI LED lights to show that data is being received by the console. Note that this operation can take a while during which time the console mute and assignment operations are interrupted.

If you are using a MIDI sequencer to record the dump out data string then make sure you play it back at the same speed you recorded it. If you dump it back into the console faster than it was recorded some data may not load correctly.

## MIDI Dump Message Format

The format for dump out and in is identical. The dump data string is made up of multiple System Exclusive messages (known as packets) which contain the console information.

**Transmit and Receive.** The format for a single packet is as follows:

F0 <SysEx header> <packet type> <packet number> <data> <checksum> F7

<SysEx header> = 00 00 1A 50 07 VV vv nn

Where VV = software version number – major  
vv = software version number – minor  
nn = console MIDI channel number

<packet no.> = packet number from 0 to 127

<data> = block of console data (7-bit format)

<checksum> = checksum to allow error detection

## MIDI Dump Errors

If the console or connected equipment fails to respond to a MIDI dump then check:

- The MIDI cable is good and correctly plugged
- The correct MIDI channel number is selected
- The console rear panel switch is set to MIDI
- Try again

## Allen & Heath ML Archiver

The ML Archiver Windows™ utility for the PC can be downloaded from the Allen & Heath Internet site. This can be used to archive data to and from the PC via MIDI or RS232.

The program also includes the useful Snapshot Manager which lets you store and recall the console mute settings and VCA group assignments from the 128 internal snapshot memories. The snapshots cannot be accessed from the console control panel itself. The archiver provides this extra feature.

Check the Allen & Heath Web site for further details and loading instructions.

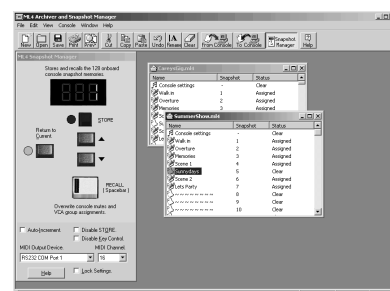

# Console Computer and Operating Software

## Operating Software Version Number

You can check the current version number of the **ML3000** software running on the console using a PC connected via RS232. Instructions for this are provided on the Allen & Heath Internet site.

## Loading New Operating Software

Check the Allen & Heath Web site for the latest version of console software. New software is loaded from a PC via the RS232 port.

**IMPORTANT ! The current console settings and snapshots may be lost when you load new operating software.** If you wish to keep your settings and snapshot contents, first archive them using the dump out facility. Restore these after loading the new software by using dump in.

Download the software from the Allen & Heath Web site to your PC computer. Connect the PC RS232 port to the console RS232 port using a standard pin-to-pin (not null modem) 9-pin serial cable. Set the console rear panel switch to the RS232 position. Power up the console. The console awaits data from the PC. Follow the instructions provided on the Web site for loading the new software into the console. When completed make sure you set the console rear panel switch back to its normal operating position, typically MIDI.

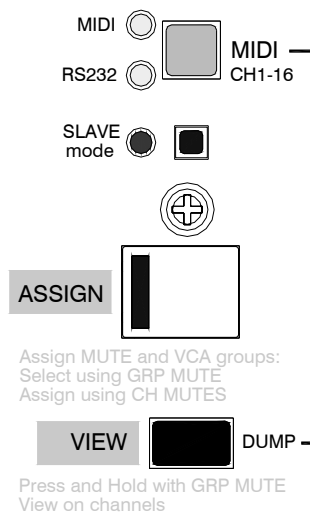

## Power Up and Power Down

The console settings are remembered when power is removed. On power up these settings are restored.

## To Reset the Console Settings

Hold down the ASSIGN and VIEW keys together while powering up the console to reset all current settings. This does not affect the contents of the snapshot memories. The default settings are restored:

- Selects normal console operating mode
- Clears all current Mute Group assignments
- Clears all current VCA Group assignments

## To Reset the Snapshot Memories

Hold down the ASSIGN and MIDI keys together while powering up the console to clear all the snapshot memories. This does not affect the current console settings. For all snapshots reset:

- Clears all stored mutes
- Clears all stored VCA Group assignments

## To reset all Settings and Memories

Hold down the ASSIGN, VIEW and MIDI keys together while powering up the console to clear all current settings and the memories.

## Internal Options Links

---

The **ML3000** is designed to offer the utmost flexibility to satisfy the application without modification. However, the following internal link options are provided to allow customisation to satisfy the more specialist applications or personal preferences. Remember to set these internal links according to the user requirement if replacing assemblies while carrying out service work:

**Mono channel AUX options** The pre-fade sends are set pre-insert, pre-EQ, post-mute as standard. Jumper links on the mono circuit cards can be replugged to configure post-insert, pre or post-EQ and/or pre-mute. Refer to drawing D1 and D2.

**Stereo channel AUX options** The pre-fade sends are set pre-EQ, post-mute as standard. Jumper links on the stereo circuit cards can be replugged to configure post-EQ and/or pre-mute. Refer to drawing D4 and D6.

**Mono channel DIRECT outputs** These are derived post channel fader as standard. A jumper link on each card can be replugged to configure pre-fader or post-fade with level trim. The direct out pre-fade source is the same as that configured to feed the aux sends. The level trim option disables the channel Aux1 send and uses its send as the direct out level control. Two links need to be set in this case, one to send the direct output signal through the send control, the other to disable the Aux1 send from the channel. Refer to drawing D1.

**2-track output source** These are set post master insert and fader as standard. Two pairs of jumper links can be replugged to derive the output pre-insert, pre-fader. Refer to drawing D27 and D28.

## Internal Assembly Assignments

---

The following assignment links need to be set according to assembly position in the console. These should not need changing unless a replacement assembly has been fitted.

**Group / Aux buss assignment** Zero ohm links determine which busses feed the group and aux mix amps. Refer to drawings D11, D12 and D13.

**Aux Matrix buss assignment** Zero ohm links determine which busses feed the aux mix amps. Refer to drawing D14 and D15.

**VU meters 1-8** The same assembly type is used for meters 1-4 and 5-8. The position in the console is determined by soldered links. Refer to drawings D48, D49 and D50.

**CPU assignment** Position the three links according to the console type as shown on drawing D23

## The Range

---

ML3000-24	24 mono, 2 stereo input - Live sound console
ML3000-32	32 mono, 2 stereo input - Live sound console
ML3000-40	40 mono, 2 stereo input - Live sound console
ML3000-SLV2	SYS-LINK V2 kit - ML3000
RPS11	3U power supply unit - For ML3000 console
002-223	2.9 metre DC power lead – To connect RPS11 power supply to console
RPSD2	Dual supply Combiner / Monitor
002-617	2.8 metre 37way Audio cable - To link sidecar to console
AL4155	2.8 meter 9way Logic cable - To link sidecar to console
AP4512	ML3000 Console User Guide
AP4511	ML3000 Console Service Manual
AP2725	RPS11 Power Supply User Guide
AP2263	RPSD2 User / Installation guide
AL4061	Gooseneck lamp 18"
AP4508	24 Channel vinyl dustcover
AP4509	32 Channel vinyl dustcover
AP4510	40 Channel vinyl dustcover

## SERVICE TOOLS

---

The tools required to service the **ML3000** are standard to an electronics service workshop and are easily obtainable. The following items are necessary for disassembly and service access:

TOOL	USE	ORDER CODE
4mm Hexagon (Allen) key	M6 side trim	AT0033
1-point Crosshead screwdriver	M3, 4AB	AT0004
2-point Crosshead screwdriver	M4, 6AB, 8B	AT0002
11mm AF Nutdriver	Potentiometer and headphone socket nuts	
12mm Nutdriver	Jack nuts	
1.27mm Hexagon (Allen) key	PSU DC Leads	AT4142
2.5MM hexagon (Allen) key	M4 Sidetrim	
5.5mm AF Spanner	Fader PCB M3 Hex	
5mm Nutspinner	D-Type Screws	
Torx-headed screwdrivers	Torx-headed screws	

## ORDERING AN ASSEMBLY

---

The following assemblies for the **ML3000** are supplied fully tested. Please quote the description and order code for the part required.

### **Printed circuit board (PCB) assemblies:**

DESCRIPTION	ORDER CODE
Mono Input PCB assembly	002-742
Stereo Input PCB assembly	002-746
Master Connector PCB assembly	002-750
Group / Aux PCB assembly	002-743
Aux Matrix PCB assembly	002-744
Master Distribution PCB assembly	002-778
SYS-LINK 2 In PCB assembly	002-634
MIDI Power PCB assembly	002-753
CPU PCB assembly	002-550
LCR PCB assembly	002-752
Master / Stereo Fader PCB assembly	002-748
Master PCB assembly	002-745
Mono Fader PCB assembly	002-747
Mono Connector PCB assembly	002-749
SYS-LINK 2 Out PCB assembly	002-636
Meter Master PCB assembly	002-755
Meter 1-8 & 9-16 V2 PCB assembly	002-716
Meter LEDBAR PCB assembly	002-754

### **IDC connector harnesses:**

DESCRIPTION	ORDER CODE
GL4000-Master harness	AL2759
10 way Master to rear harness	AL4605
16 way LRC to rear harness	AL4606
10 way LRC Fader harness	AL4607
26 way Mono Fader harness	AL4608
34 way MPC to Master Fader harness	AL4609
10 way Master to Master Fader harness	AL4610
26 way CPU to PSU (Power) harness	AL4611
10 way CPU to PSU (MIDI) harness	AL4612
ML3-40 26 way Main harness	AL4613
ML3-24 26 way Main harness	AL4617
ML3-32 26 way Main harness	AL4618
10 way Dist. to rear Connector harness	AL4624
16 way Master Interconnect harness	AL4625

20 way Stereo Fader harness	AL4626
20 way Dist. to Meter harness	AL4657
10 way Meter Power harness	AL4664

### **THE CHASSIS TRIM**

<b>DESCRIPTION</b>	<b>ORDER CODE</b>
ML3000 (all formats) Left & Right Chassis side trims	AA4432-L/R
Left & Right Moulded side trims	AA4433-L/R
Ident strip Master	AK4439
Ident strip Master Rear	AK4440
Ident strip ML5 1-24	AK3789
Ident strip ML5 1-24 Rear	AK3790
Ident strip ML5 25-48	AK3795
Ident strip ML5 25-48 Rear	AK3796

## **ORDERING AN ML3000 SPARES KIT**

It is recommended that the spares kit order code **002-781** is held and maintained by the service agent to enable in-field service repairs to the **ML3000** independent of the ALLEN & HEATH factory. Commonly available items such as resistors, capacitors, tools and soldering equipment are not included. The contents of the kit are listed below and are supplied in a cabinet of drawers. Individual spare parts may be ordered. Please quote the description and order code for the part required.

### **Fixings:**

<b>DESCRIPTION</b>	<b>ORDER CODE</b>	<b>QTY</b>
INSUL WASHER TO220 3X1.5MM	AA3247	5
SCREW 4ABX5/16 CSK TORX BK	AB0059	20
SCREW M3X6MM PAN TORX BK	AB0072	10
SCREW M3X8 PAN TORX BK	AB0073	10
SCREW M3X16 PAN TORX BK	AB0079	5
SCREW M4X25 PAN TORX ZNC	AB0082	5
SCREW M3X10 CSK POZI BK	AB0093	5
NUT M3 NYLOCK	AB0102	10
NUT M4 FULL	AB0105	5
NUT M4 NYLOCK	AB0188	5
SCREW M3X4 PAN TORX BLK	AB0233	20
SCREW 4ABX1/2" PAN TORX BK	AB0250	5
JOINT BLOCK 30% GLASS FILLED	AB0253	10
WASHER M5 SHAKEPROOF	AB0304	5
SCREW M6X20 CSK TORX BK	AB0310	5
SCREW 6BX3/8 CSK TORX ZNC	AB2082	5
SCREW 6BX1/4 TRUNC POZI ZINC	AB2083	5
SCREW 8BX3/8 CSK POZI BK	AB2085	5
SCREW M4X8 CSK TORX BK	AB2777	5
SCREW 6BX5/16 PAN TORX BK	AB2809	20
SCREW 4X5/16 PAN POLY TORX BK	AB2810	50
SCREW M2X4 CSK POZI BK	AB3329	10
SCREW M3X4 PAN TORX BLK	AB3852	25
SCREW M6X12 CSK TORX ZINC	AB4036	5
WASHER M4.5X25MM ZINC	AB4707	5
SCREW M4X20 CSK TORX BK	AB4717	5
NUT POT 9MM	AB8050	75
FEET SCREW FIXING 18DIA 17.5MM	AK4415	6

### **Knobs and caps:**

<b>DESCRIPTION</b>	<b>ORDER CODE</b>	<b>QTY</b>
KNOB 11MM GREY-RED	AJ2074	10
KNOB 11MM GREY-BLUE	AJ2075	30
KNOB 11MM GREY-LIGHT BLUE	AJ2076	30



KNOB 11MM GREY-GREEN	AJ2077	15
KNOB 11MM GREY-GREY	AJ2078	20
KNOB 11MM GREY-YELLOW	AJ2079	15
KNOB 11MM GREY-BROWN	AJ2080	15
PUSH BTN RECT GREY CK 10X5	AJ2865	5
PUSH BTN RECT BLACK CK 10X5MM	AJ3228	5
PUSH BTN 5MM SQ RED	AJ3488	20
FADER KNOB 11MM BK-WH TBAR	AJ3503	10
SWITCH CAP OFFSET LT BL/GY TOP	AJ3863	20
SWITCH CAP OFFSET LT BL/WH TOP	AJ3950	10
PUSH BTN SQ WHITE 6X6MM 23/PB0	AJ3951	10
PUSH BTN SQ L/GREY 6X6MM 23/PB	AJ3952	5
PUSH BTN SQ BLACK 6X6MM 23/PB0	AJ3954	5
PUSH BTN L/GREY ROUND 8MM	AJ3955	10
FADER KNOB 11MM WH-BK T	AJ8078	5
FADER KNOB 11MM RED-BK T	AJ8079	5
FADER KNOB 11MM YEL-BK T	AJ8080	5
FADER KNOB 11MM BL-BK T	AJ8081	5
BTN ILLUM WHITE LARGE	AJ8107	10

**Faders, Potentiometers, Switches and connectors:**

DESCRIPTION	ORDER CODE	QTY
FLEX CABLE 12WAY 90MM	AH2228	10
FLEX CABLE 15WAY 90MM	AH4091	5
POT ALPS 14MM 10KCX2 (103C)	AI0150	5
FADER ALPS 100MM 10KLIN SLIM	AI3313	10
FADER ALPS 60MM 10KA DUST	AI3497	5
POT ALPS 11MM 10K SPCL (103)	AI3838	10
POT ALPS 11MM 20KK (203K)	AI8003	20
POT ALPS 11MM 20KB C/D (203B)	AI8004	15
POT ALPS 11MM 200KCX2 (204C)	AI8005	10
POT ALPS 14MM 20KBX2 ST C/D	AI8006	10
POT ALPS 14MM 20KKX2 ST (203K)	AI8007	5
POT ALPS 14MM 10K ST C/D 103AC	AI8008	10
POT ALPS 14MM 200KCX2 (204C)	AI8009	10
POT ALPS 11MM 5K RD REV 502RD	AI8111	5
FADER ALPS 100MM 10KD(T) DUST	AI8117	5
SWITCH 2PCO LATCH SINGLE	AL0162	30
JACK SKT STEREO SW PCB CHROME	AL0328	2
JACK SKT 1/4" ST PCB MET	AL4713	2
JACK NUT NKL PTD BRASS RING	AL4715	2

SWITCH 4PCO LATCH	AL0333	10
JUMPER SOCKET 2WAY	AL0334	15
SWITCH ALPS 2PCO MOM	AL0374	10
FLEX SKT 12WAY 90DEG	AL2226	5
FLEX SKT 12WAY STRT	AL2227	5
XLR FEM 3PIN VERT PCB	AL2410	5
XLR MALE 3PIN VERT PCB	AL2411	5
SWITCH SLIDE MINI SPDT PCB	AL3081	2
JACK SKT 1/4" ST V MET UNSW	AL3407	5
JACK SKT 1/4" ST V MET	AL3410	10
CRIMP TERMINAL RING 4BA INSUL	AL3449	5
MOLEX 0.1" MALE 10X2PIN STRT	AL3451	5
MOLEX 0.1" MALE 5X2PIN 90DEG	AL3512	5
BOX HEADER 0.1" 26WAY 90DEG	AL3592	5
FLEX SKT 15WAY 90DEG	AL4076	5
MOLEX 0.1" MALE 5WAY 90DEG LCK	AL4270	5
TERMINAL SCREW PCB MOUNT	AL4303	5
MOLEX 0.1" FEM 5X2PIN STRT	AL4306	5
MOLEX 0.1" MALE 5WAY STRT LCK	AL4594	5
WFM ASSY ML3 FADER	AL4619	10
SWITCH ALPS 2PCO LATCH 90DEG	AL8065	5

### **LEDs and Semiconductors:**

DESCRIPTION	ORDER CODE	QTY
DIODE 1N4148 SIGNAL	AE0007	25
TRANSISTOR BC549 NPN	AE0020	10
TRANSISTOR BC214C PNP	AE0031	2
IC TL072 OP-AMP	AE0046	25
IC LM339N COMPARATOR	AE0071	5
TRANSISTOR J111N FET T092B	AE0083	10
LED T1 3MM YELLOW	AE0084	10
LED T1 3MM GREEN	AE0085	10
LED T1 3MM RED	AE0086	10
IC CMOS 4053B - CD4053BCN	AE0117	1
IC CMOS 4051B - CD4051BCN	AE0118	2
IC NE5532N OP-AMP	AE0221	20
IC 6N136 OPTO-ISOLATOR	AE0222	1
IC REGULATOR 7805	AE0308	1
IC CMOS 74HC165	AE2749	1
IC CMOS 74HC4094N	AE2755	2
IC LM393N COMPARATOR	AE2818	5

TRANSISTOR BC556B PNP	AE3001	1
CRYSTAL 14MHZ	AE3007	1
TRANSISTOR SMD BC858B	AE3042	2
IC DS1233-5 TO92 POWER RESET	AE3066	1
TRANSISTOR MOSFET BSS138	AE3498	1
IC CMOS 74HCT02	AE3988	1
IC THAT2155 VCA	AE4279	10
TRANSISTOR 2SB737 PNP	AE8069	10

### **Miscellaneous:**

DESCRIPTION	ORDER CODE	QTY
METER VU NISSEI +8V BULB NEW	AD4322	3
BEAD FERRITE AXIAL	AF0610	5
CABLE TIE 2.6X90MM	AK0151	5
INDUCTOR 4.7UH 600MA	AM3467	2
BATTERY NI-MH 2.4V 150MAH	AP4355	2

### **Power Supply:**

DESCRIPTION	ORDER CODE	QTY
LAMP MAINS NEON 12 DIAM	AL0200	2
FUSE 20MM 3.15A A/SURGE (UK, EC)	AL0464	5
FUSE 20MM 5A A/SURGE (USA)	AL2270	5
FUSE 20MM 8A A/SURGE (DC)	AL0487	5
TRANSFMR RPS11 320VA	AM2720	-
BRIDGE RECTIFIER 35A 600V	AE0239	1
TRANSISTOR MJ11016	AE0240	2
TRANSISTOR COVER T03	AK2767	2
THYRISTOR TIC126M 12A	AE0272	1
IC REGULATOR 783	AE0214	2
IC REGULATOR UA723CN	AE0056	2
FUSE HOLDER 20MM PANEL 10A	AL4219	1
DC CABLE ASSY (10 PIN PLUG → 10 PIN SOCKET)	002-223	-

**Fitting Instructions for ML3000-SLV2 Kit**







These are the instructions for fitting the SYS-LINK Version 2 console expander option kit to the **ML3000** console. This work must be carried out by technically qualified service personnel only.

Whilst we believe this information to be reliable we do not assume responsibility for inaccuracies. We also reserve the right to make changes in the interest of further product development.

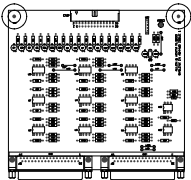
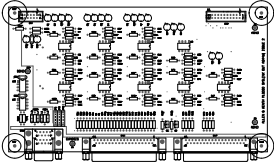
For information on how to use the SYS-LINK option please refer to the Applications Note AP4722. For further information on the **ML3000** console refer to User Guide AP4512 and Service Manual AP4511.

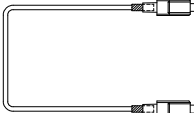
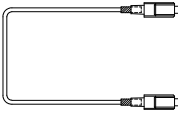
**Contents.**

Check the contents of your ML3000-SLV2 kit:

1 x 002-634	PCB Assembly ML3 SYS-LINK II IN	
1 x 002-636	PCB Assembly ML3 SYS-LINK II OUT	
3 x AK0151	Cable Tie 2.6 x 90mm	
2 x AH4131	37way D-type Audio Cable ML5 SYS-LK	
1 x AL4155	9way D-type RS422 Cable ML5-SC	
1 x AL4684	IDC Harness ML3 10way SYS-LINK Power	
1 x AL4685	IDC Harness ML3 20way SYS-LINK OUT	
1 x AL4686	IDC Harness ML3 26way SYS-LINK IN	
1 x AP4721	Fitting Instructions (This document)	
1 x AP4722	Applications Note	

## Software Compatibility

---

The **ML3000** must be loaded with **V1.31** or higher operating software for the SYS-LINK option to function correctly. You can check the current version number of the console software using a PC connected via RS232. Instructions for this and the latest version of software are provided on the Allen & Heath Internet site

<http://www.allen-heath.com/>

## Tools and Facilities Required

---

This work requires removal of the console base panel, fitting two internal circuit card assemblies and plugging on IDC cable harnesses. To use SYS-LINK the option must be installed into both consoles to be connected.

Provide a suitably large, well lit area such as in a service workshop. To avoid damage to the cosmetics of the console ensure that the work surface is clean and clear of obstructions. Allow enough time to carry out the installation and check the results. Allen & Heath do not assume responsibility for damage due to incorrect installation of this option or it being carried out by unqualified personnel.

Normal workshop tools are required. Depending on the age of the console these include either size 1 and 2 Pozidriv (cross head) or size T10 and T15 Torx (star head) screwdrivers. A 5mm nut spinner or spanner is also needed.

## Fitting Instructions.

---

Note that these diagrams show the 24 channel ML3000. The same procedure applies to all models.

**Step 1:** Before installation, remove console power and disconnect all cables and attachments. Ensure adequate lighting and use the correct tools.

**Step 2:** Invert the console and remove the screws securing the base. Carefully lift the base off, retaining all screws.

**Step 3:** Remove the three blanking plates (10 screws) located inside the rear connector panels - [Fig.1](#). The two circuit cards are to be fitted here.

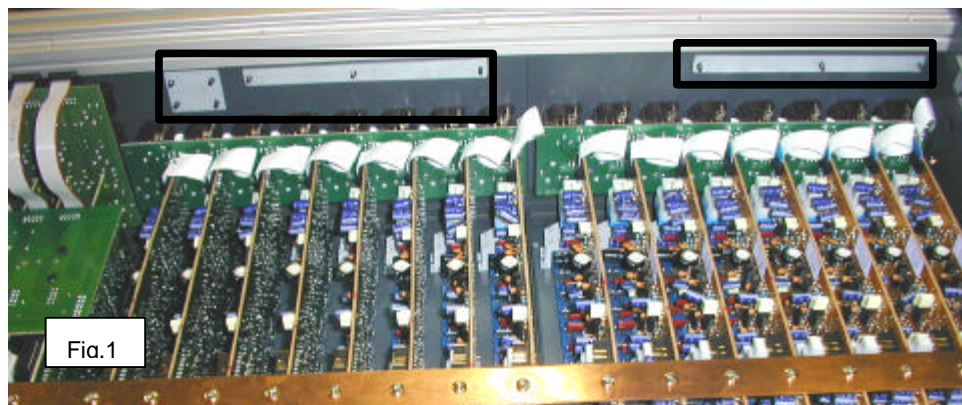



**Step 9:** Fit the 26way harness AL4686 to the SYS-LINK IN card CN3 [Fig.6](#)

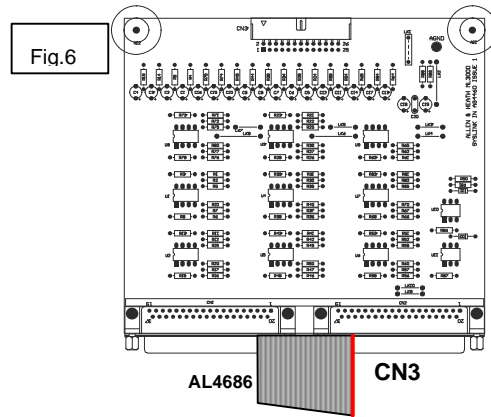

**Step 10:** Fit the SYS-LINK IN card into the console using the 4 D-type fixing nuts (supplied fitted to the assembly). Use a 5mm nut spinner [Fig.7](#)

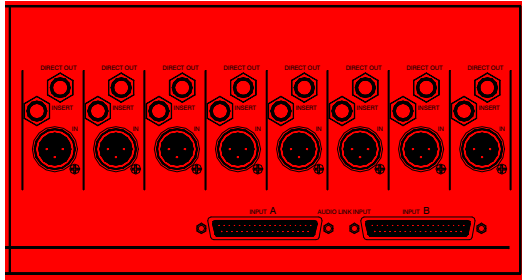

**Step 11:** Fit the free end of 26way harness AL4686 to the male connector socket on the main console IDC buss harness [Fig.8](#) and [Fig.9](#)

**Step 12:** Check that all harnesses are securely aligned and fitted. Check your work and remove any dirt or debris from within the console. Re-fit the base panel.

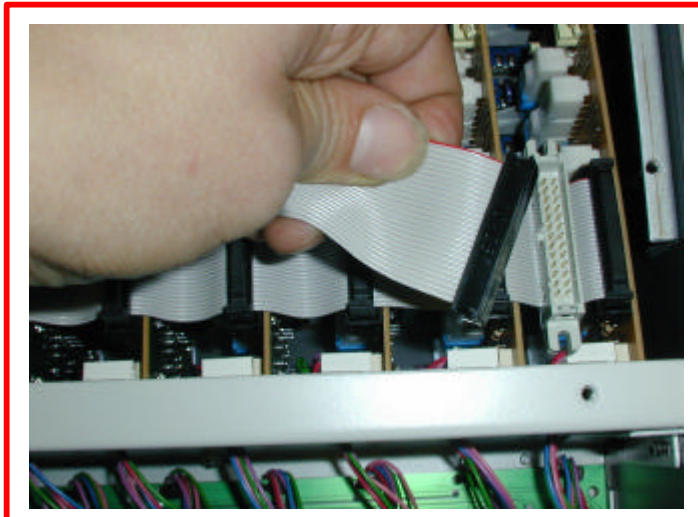
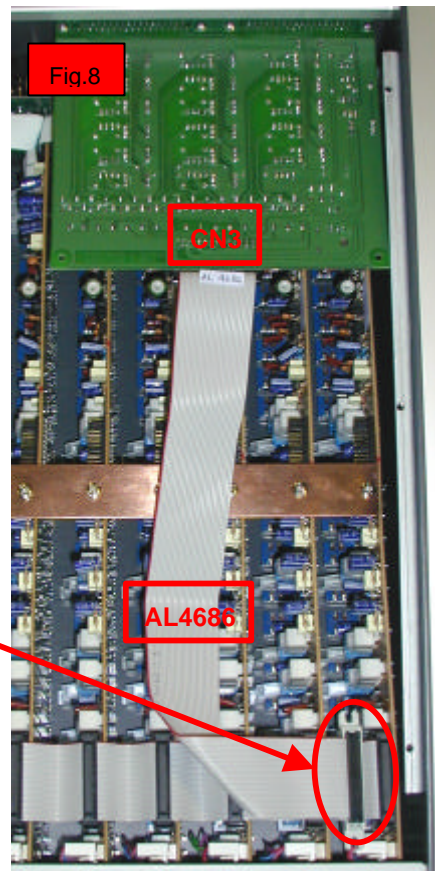

**Step 13:** Connect power and test the SYS-LINK system for correct operation. Refer any queries to Allen & Heath technical support.

## Technical Drawings

The following section includes the full set of technical drawings associated with the **ML3000**.

The **BLOCK DIAGRAM** is the same as printed in the User Guide and illustrates the signal flow through the console.

The **MAP DRAWINGS** show the interconnection between the various circuit assemblies.

The **PCB** and **CIRCUIT** drawings show the details for each assembly. Option and assignment links are marked where appropriate. The drawings included are listed in the contents at the start of this manual.

If you have any queries or require further information please contact Allen & Heath.



h  
g  
f  
e  
d  
c  
b  
a

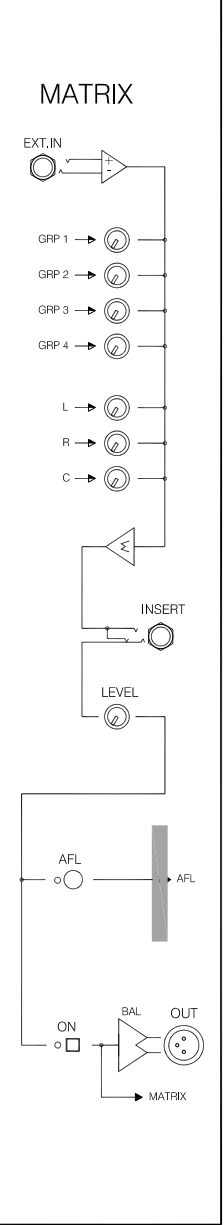
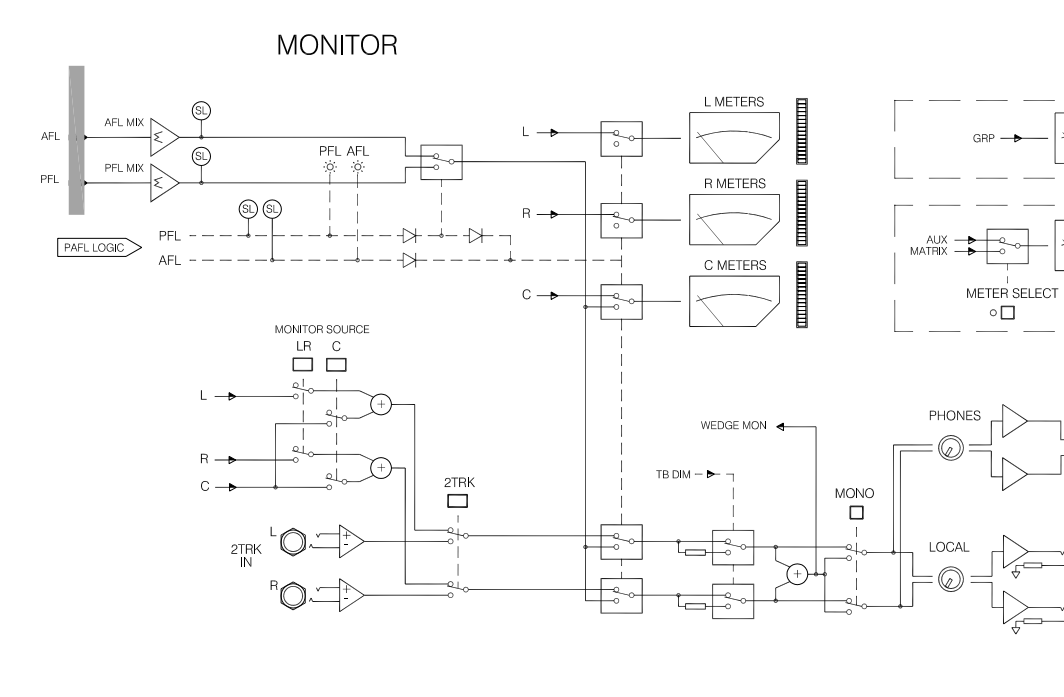
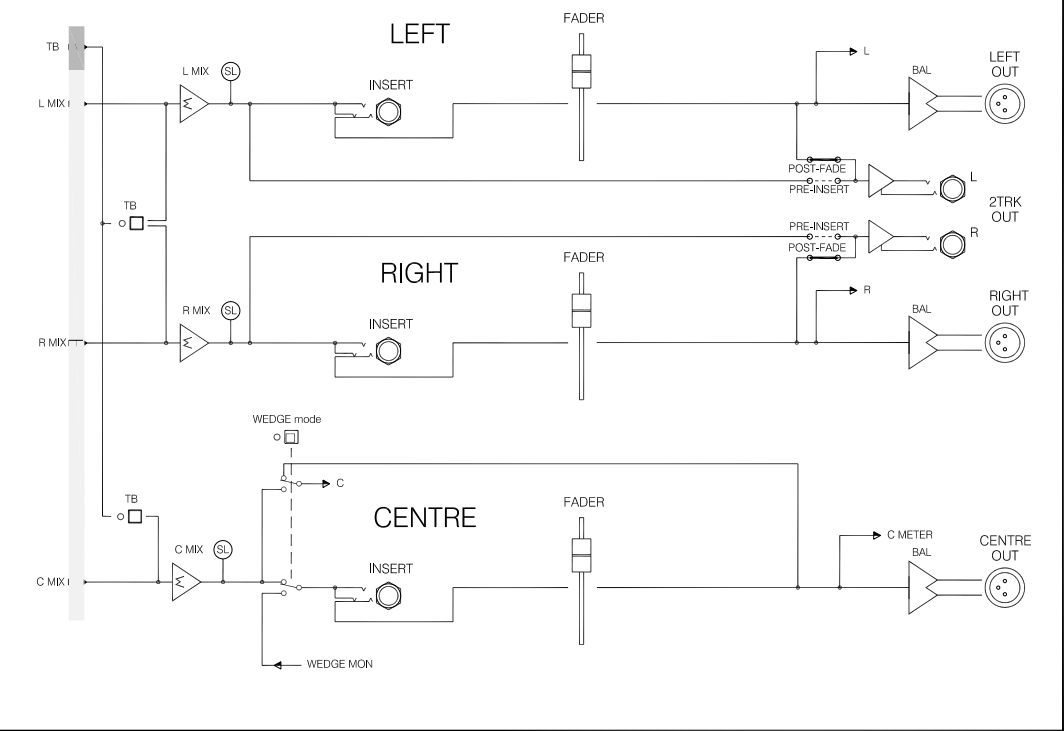
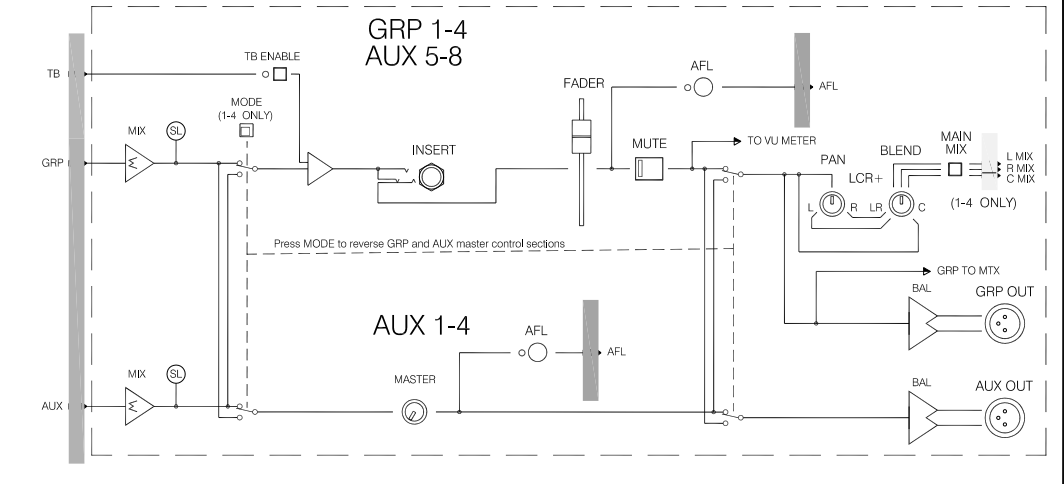
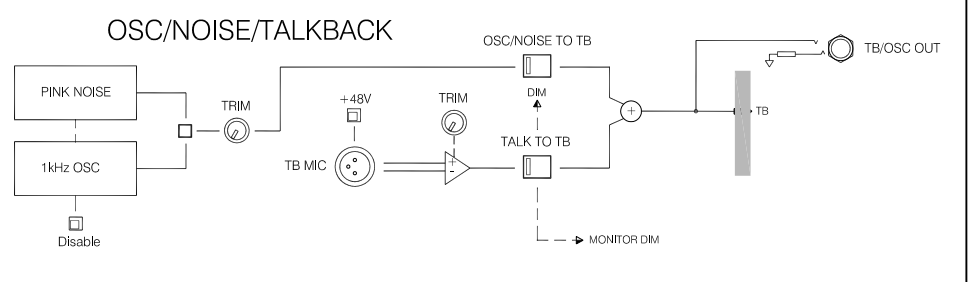
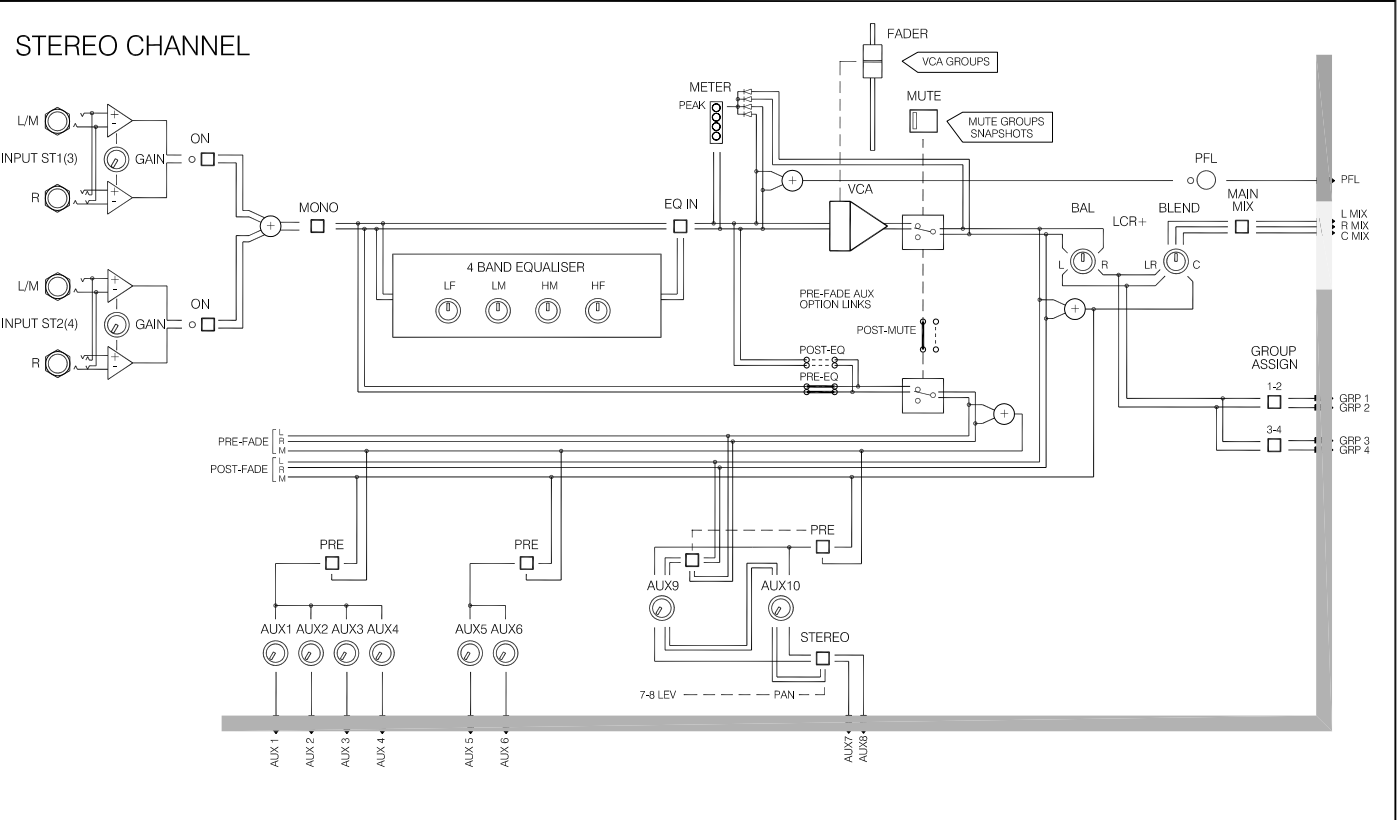
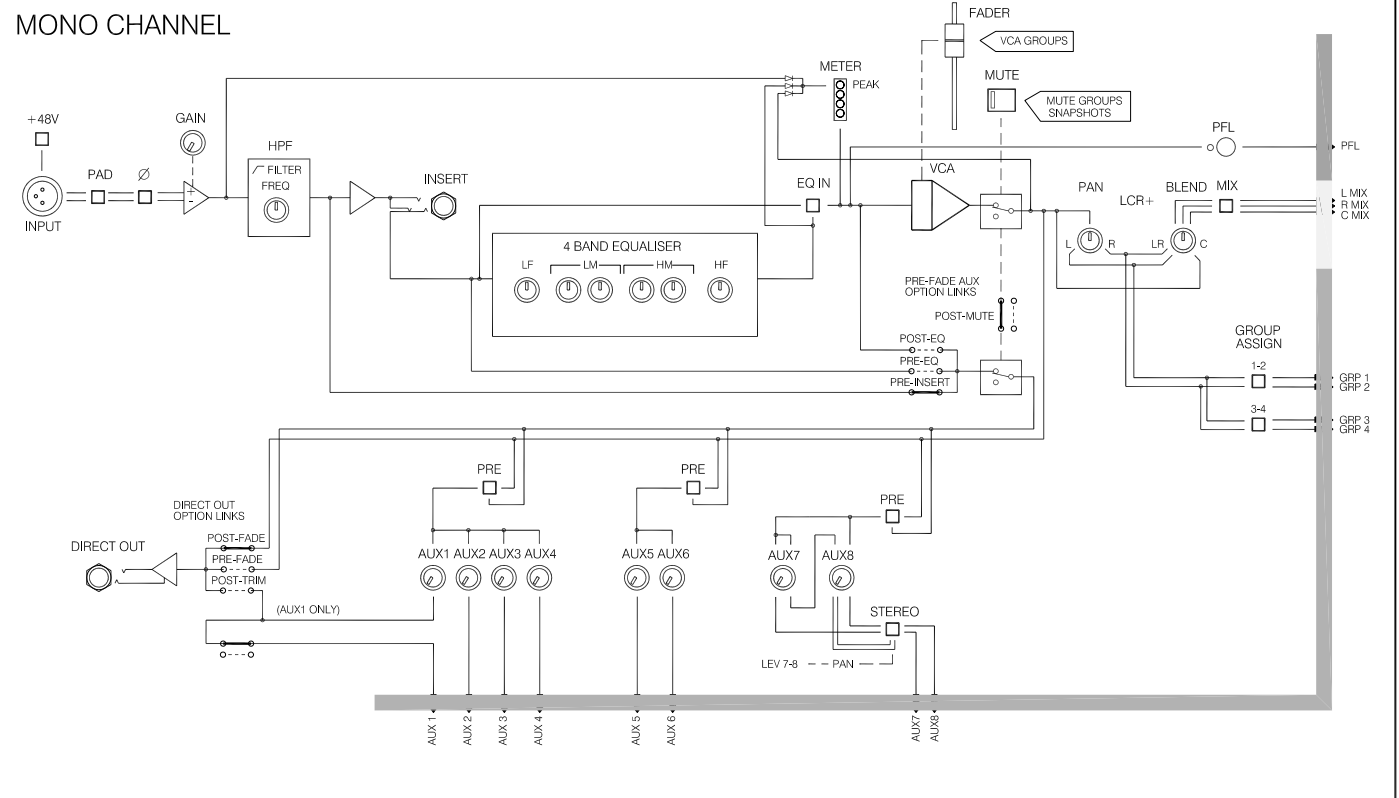

ML3000 BLOCK DIAGRAM

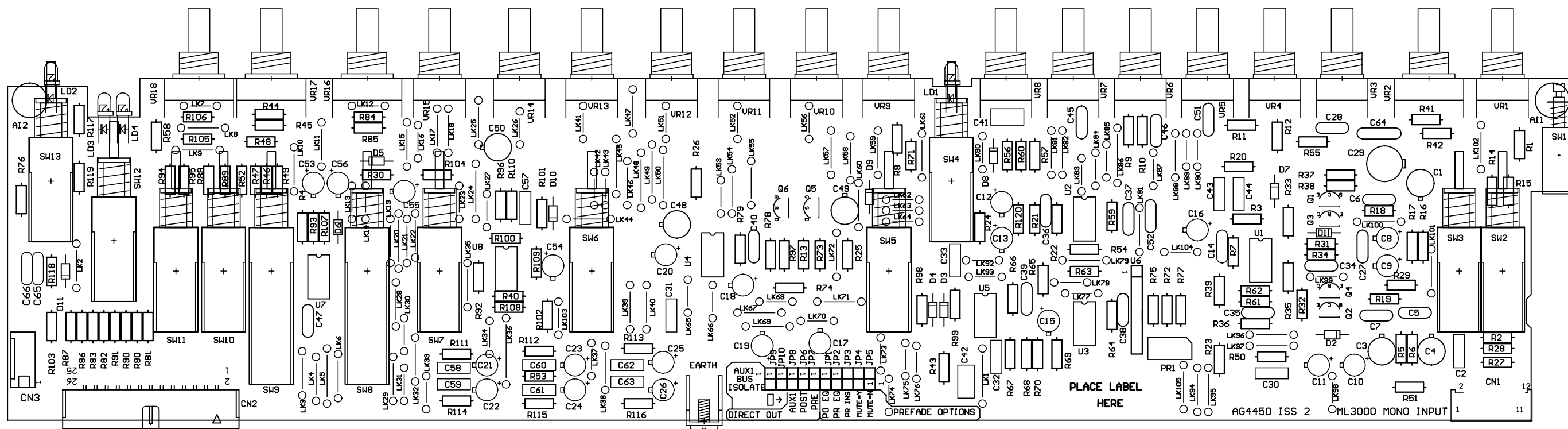

**ALLEN & HEATH**  
 Kernick Industrial Estate,  
 Penryn, Cornwall,  
 England. TR10 9LU  
 Tel: +44 (0)8707 556250  
 Fax: +44 (0)8707 556251

FILE: AG4450\_2.Pcb

PRINTED: 09:39:36 10-DEC-2001

TITLE: ML3000 MONO INPUT

DRG No: AG4450 ISSUE: 2

ALLEN&HEATH ML3000 SERVICE MANUAL

D1

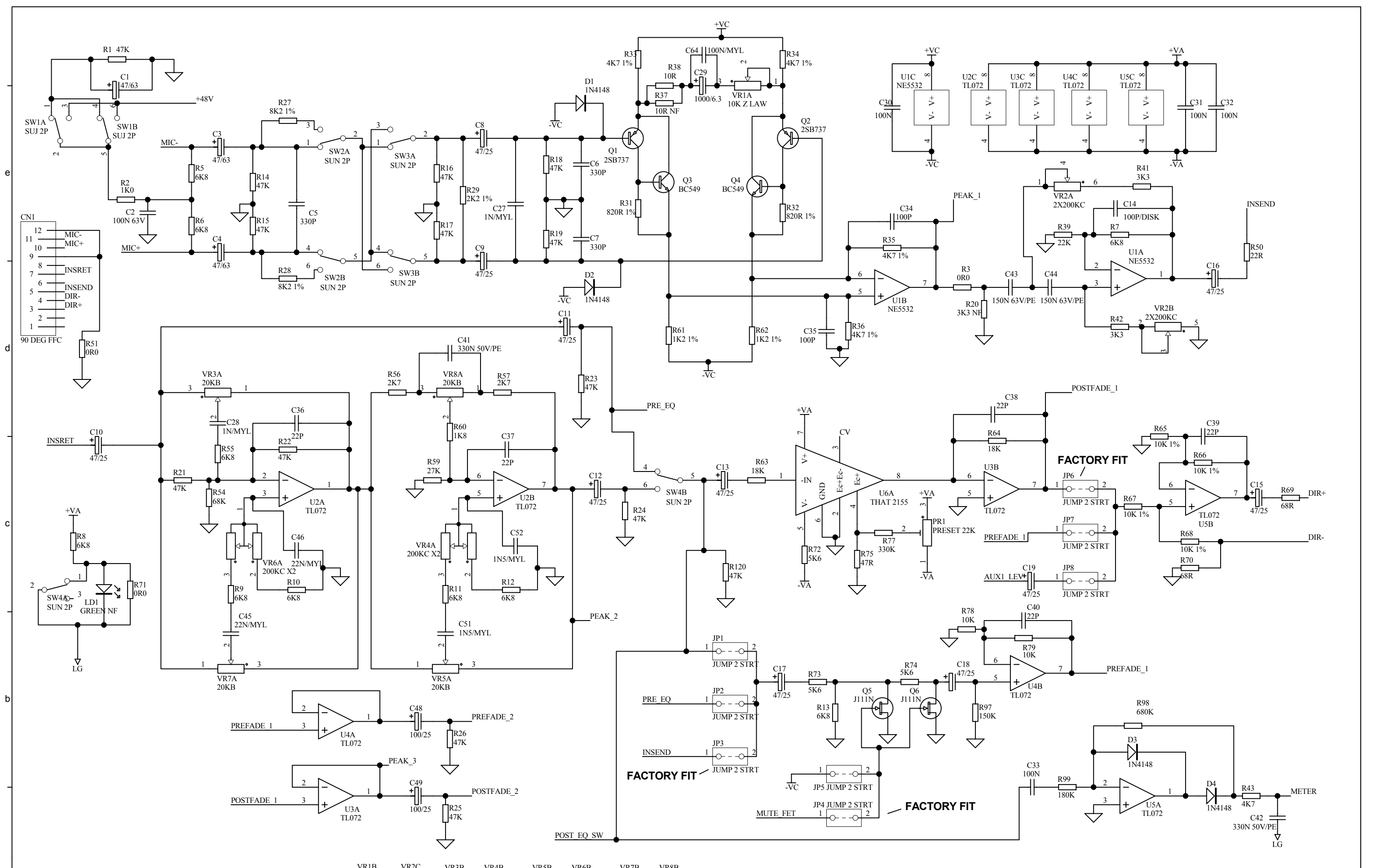

**ALLEN&HEATH**  
 Kernick Industrial Estate,  
 Penryn, Cornwall,  
 England. TR10 9LU  
 Tel: +44 (0)8707 556250  
 Fax: +44 (0)8707 556251

ISSUE	BY	DATE

VR1B 10K Z-LAW BRKT	VR2C 20K BRKT	VR3B 20K BRKT	VR4B 200KC X2 BRKT	VR5B 20K BRKT	VR6B 200KC X2 BRKT	VR7B 20K BRKT	VR8B 20K BRKT
POT_GND							

FILE: C4450_2P1.Sch	PRINTED: 11:11:35 12-Dec-2001	TITLE: ML3000 MONO INPUT
DRG No: C4450	ISSUE: 2	SHEET: 1 OF 2

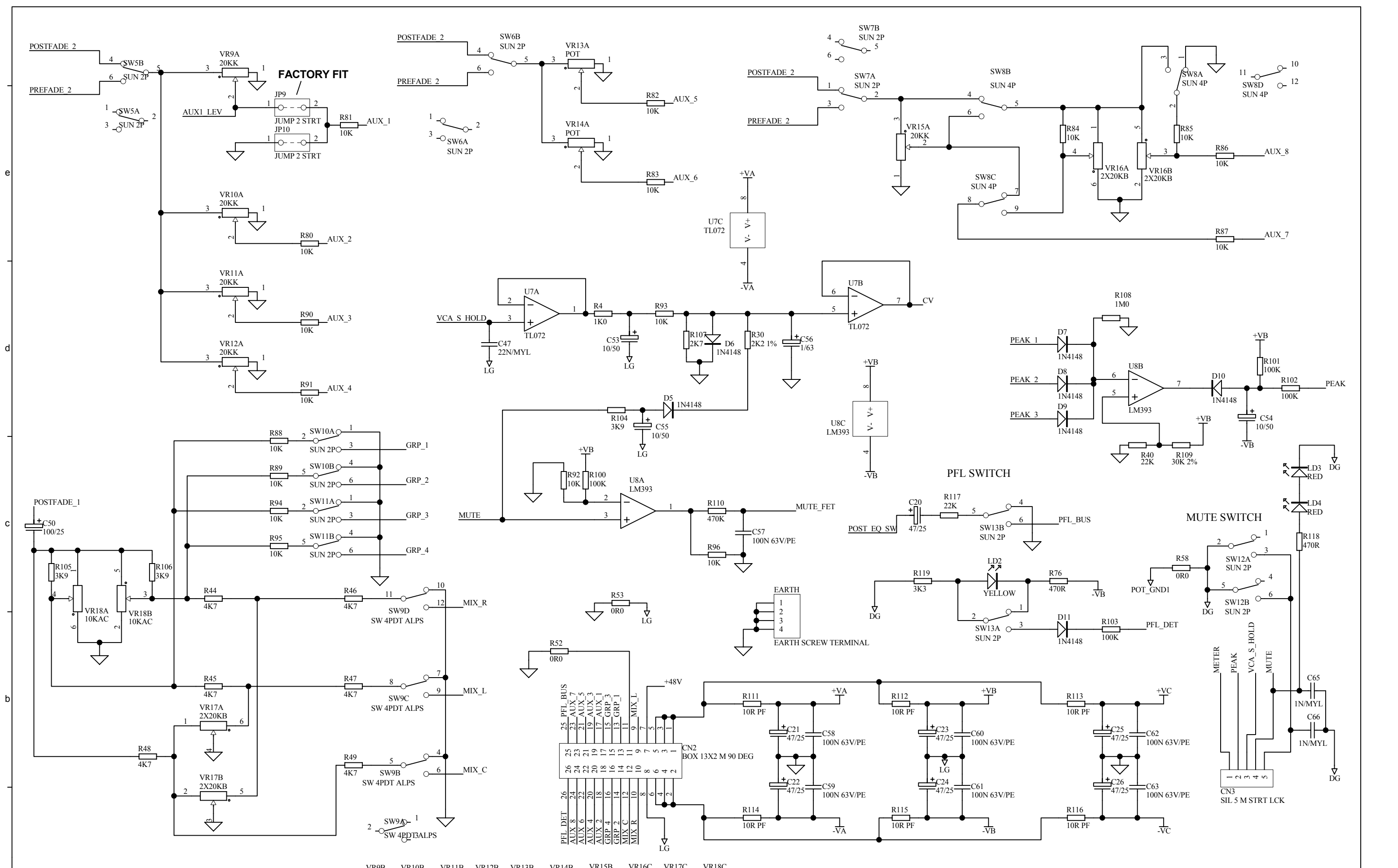

**ALLEN & HEATH**  
 Kernick Industrial Estate,  
 Penryn, Cornwall,  
 England. TR10 9LU  
 Tel: +44 (0)8707 556250  
 Fax: +44 (0)8707 556251

ISSUE	BY	DATE

VR9B 20KK BRKTL  
 VR10B 20KK BRKTL  
 VR11B 20KK BRKTL  
 VR12B 20KK BRKTL  
 VR13B 20KK BRKTL  
 VR14B 20KK BRKTL  
 VR15B 20KK BRKTL  
 VR16C 2X20KB BRKTL  
 VR17C 2X20KB BRKTL  
 VR18C 10KAC BRKTL

FILE: C4450\_2P2.Sch    PRINTED: 11:16:29 12-Dec-2001

TITLE: **ML3000 MONO INPUT**  
 PAGE:     
 DRG No: **C4450**    ISSUE: **2**    SHEET: **2 OF 2**

e  
d  
c  
b  
a

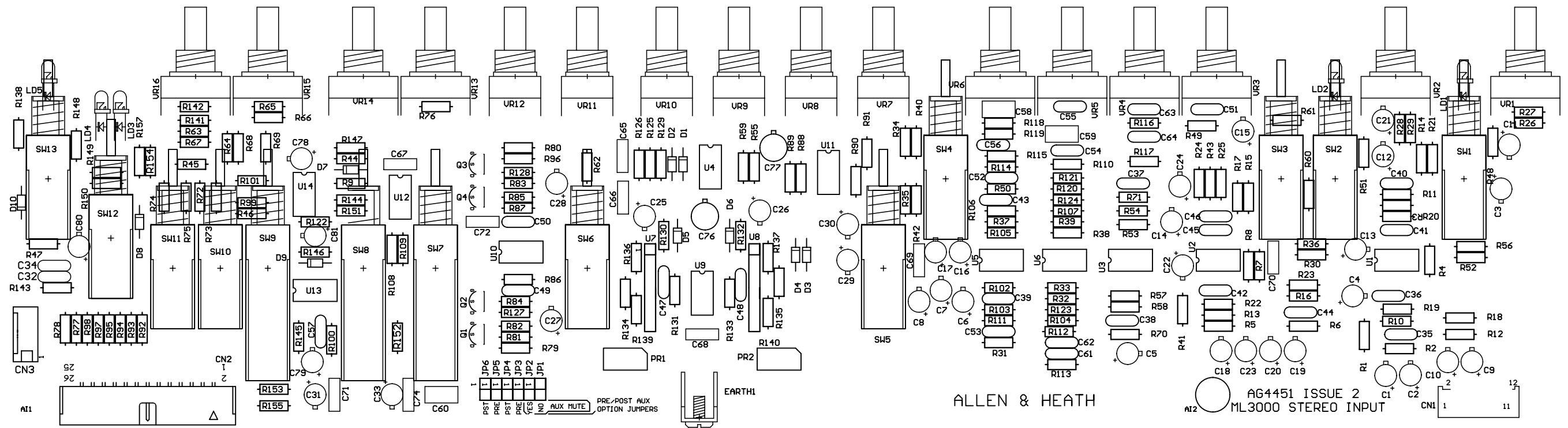

**ALLEN & HEATH**  
 Kernick Industrial Estate,  
 Penryn, Cornwall,  
 England. TR10 9LU  
 Tel: +44 (0)8707 556250  
 Fax: +44 (0)8707 556251

FILE: AG4451\_2.PCB  
 .GTO  
 PRINTED: 13:44:03 12-Dec-2001

TITLE: **ML3000 STEREO INPUT**  
 DRG No: **AG4451** ISSUE: **2**

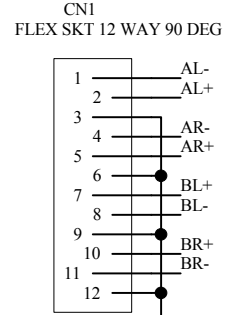
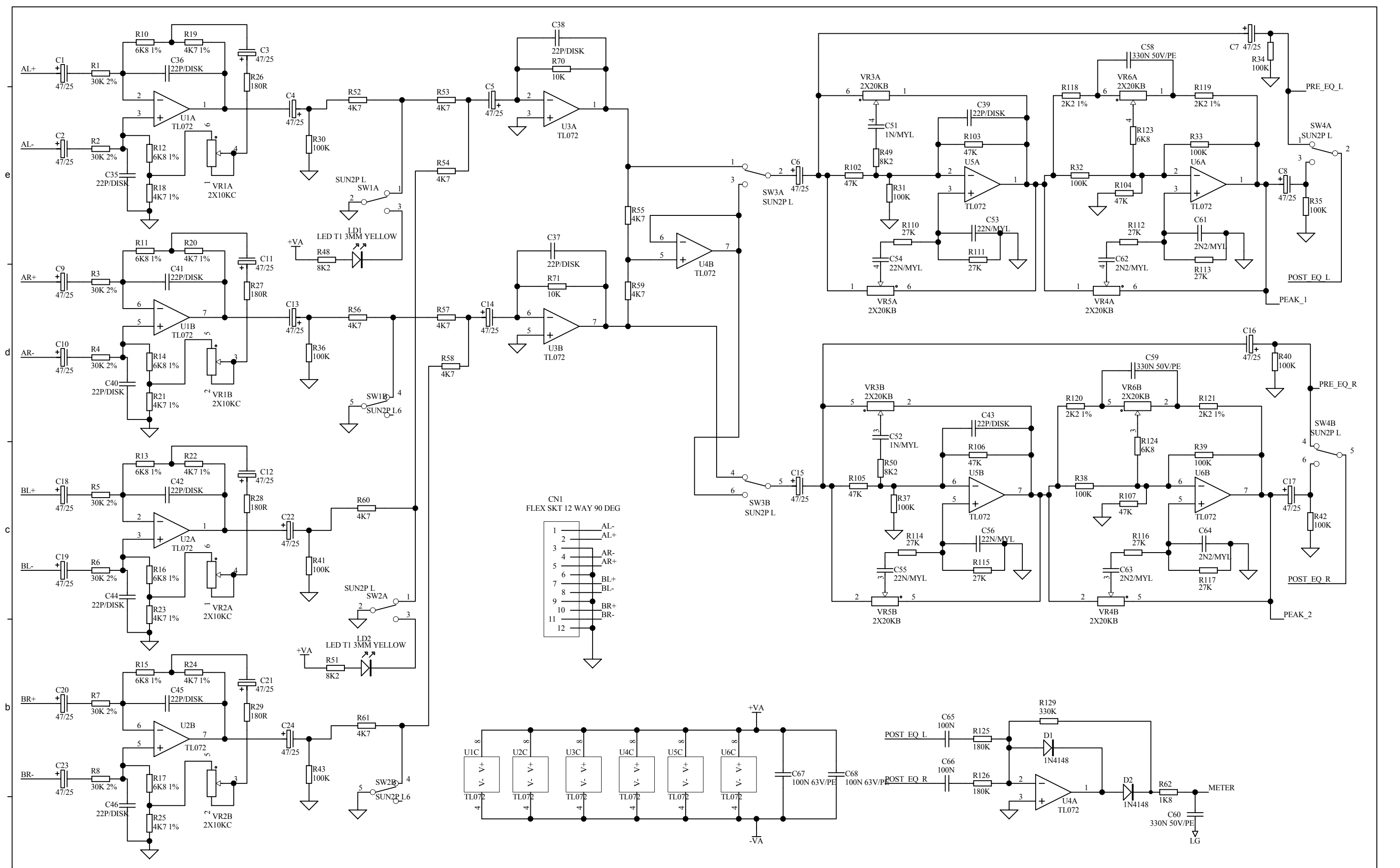

**ALLEN&HEATH**  
 Kernick Industrial Estate,  
 Penryn, Cornwall,  
 England. TR10 9LU  
 Tel: +44 (0)8707 556250  
 Fax: +44 (0)8707 556251

ISSUE	BY	DATE

VR1C 2X10KC BRK1	VR2C 2X10KC BRK1	VR3C 2X20KB BRK1	VR4C 2X20KB BRK1	VR5C 2X20KB BRK1	VR6C 2X20KB BRK1
FILE: C4451_2.1P1.Sch	PRINTED: 13:51:38	12-Dec-2001			

TITLE: **ML3000 STEREO INPUT**  
 PAGE:    
 DRG No: 4451      ISSUE: 2.1 SHEET: 1 OF 3

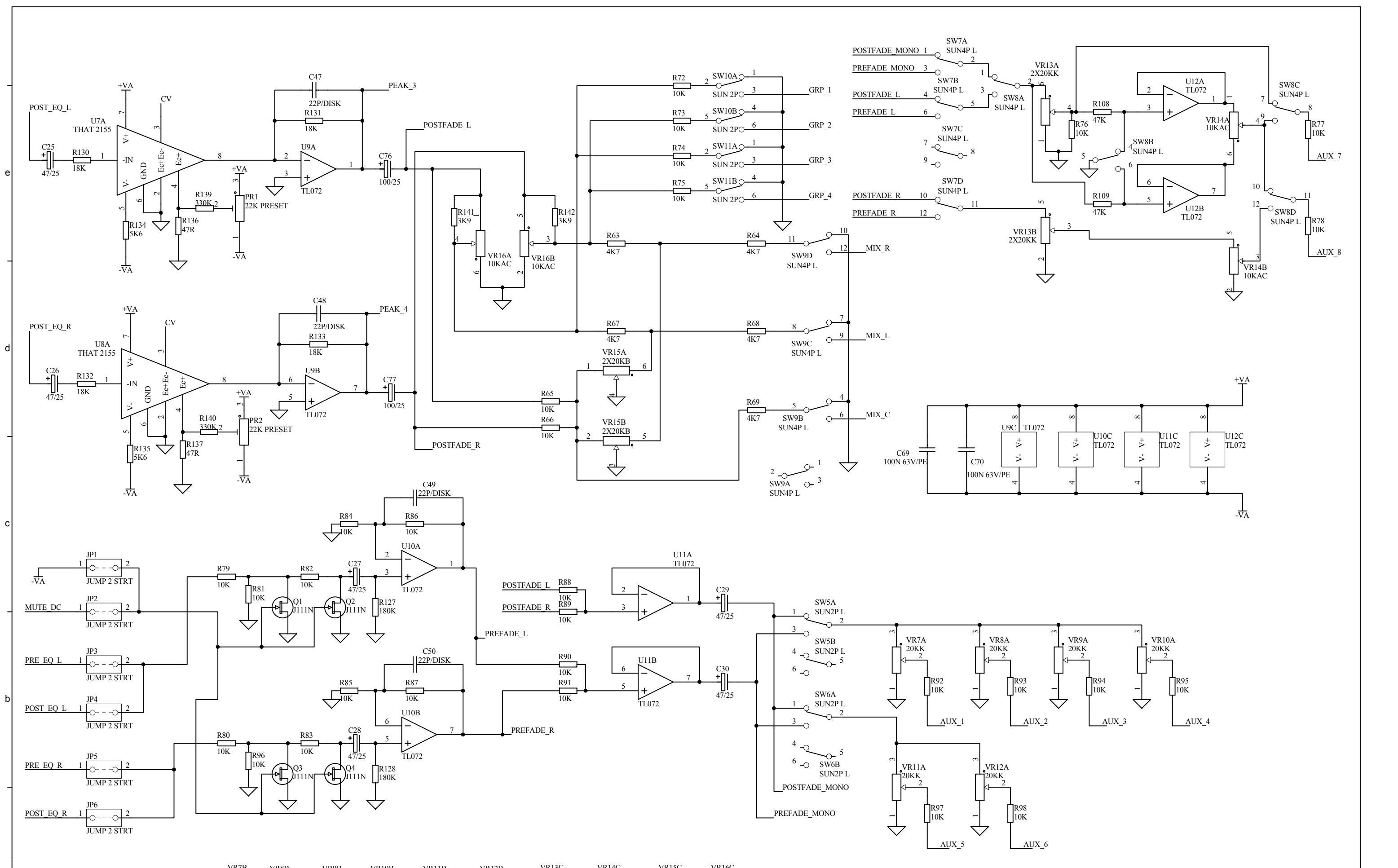

**ALLEN&HEATH**  
 Kernick Industrial Estate,  
 Penryn, Cornwall,  
 England. TR10 9LU  
 Tel: +44 (0)8707 556250  
 Fax: +44 (0)8707 556251

VR7B 20KK BRKT	VR8B 20KK BRKT	VR9B 20KK BRKT	VR10B 20KK BRKT	VR11B 20KK BRKT	VR12B 20KK BRKT	VR13C 2X20KK BRKT	VR14C 10KAC BRKT	VR15C 2X20KB BRKT	VR16C 10KAC BRKT	POT_GND1
FILE: C4451_2.1P2.Sch										
PRINTED: 13:56:20 12-Dec-2001										

TITLE: **ML3000 STEREO INPUT**  
 PAGE:  
 DRG No: 4451 ISSUE: 2.1 SHEET: 2 OF 3

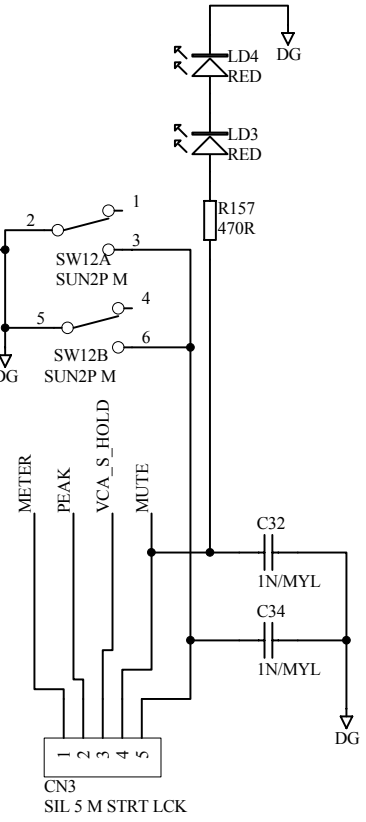
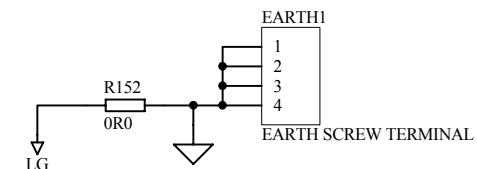
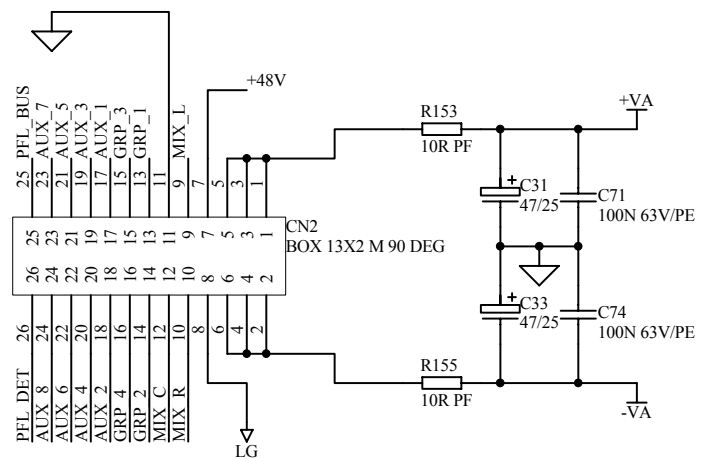
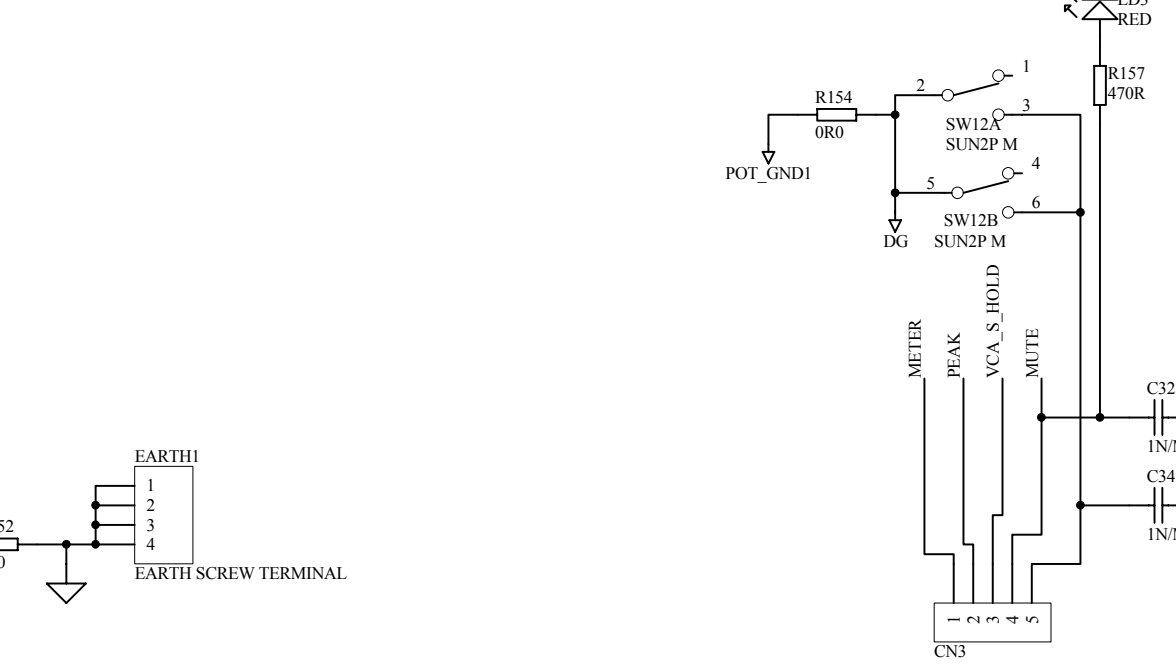
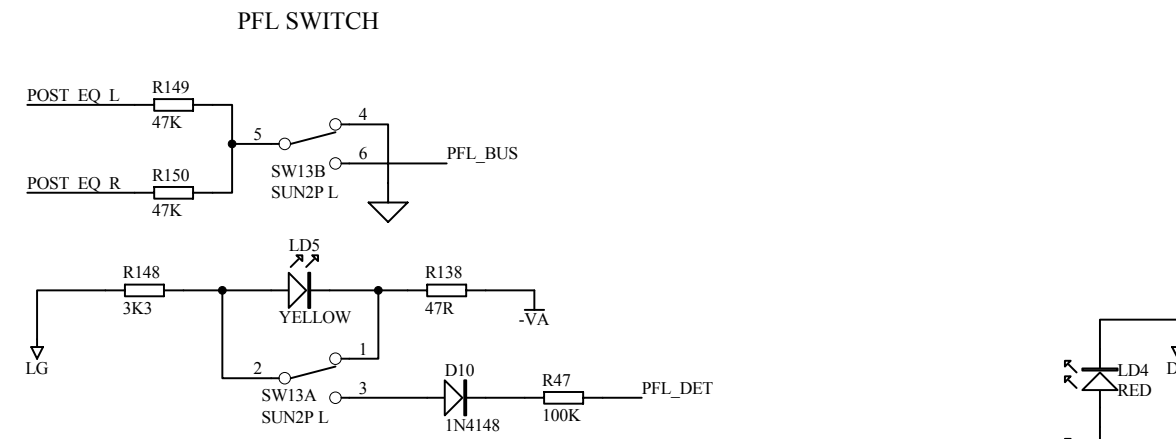
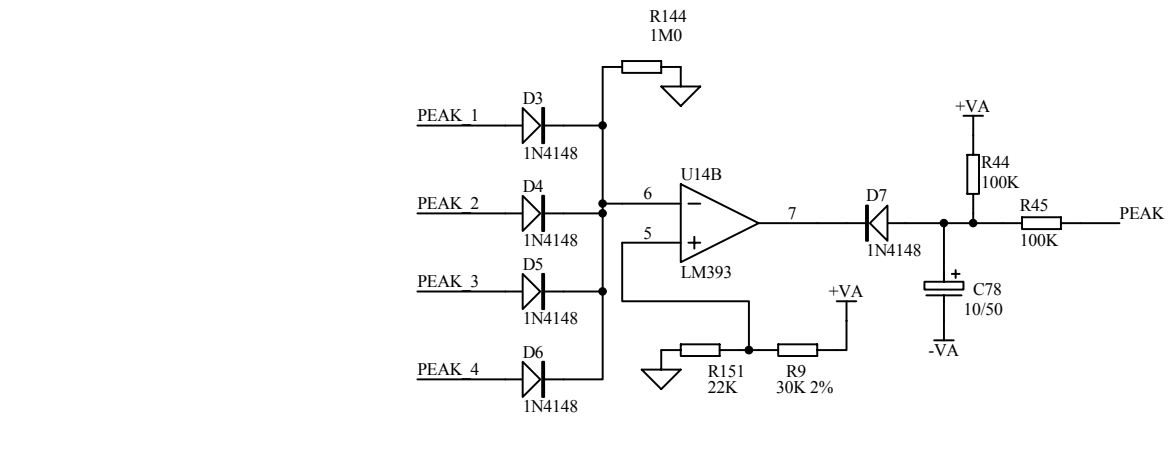
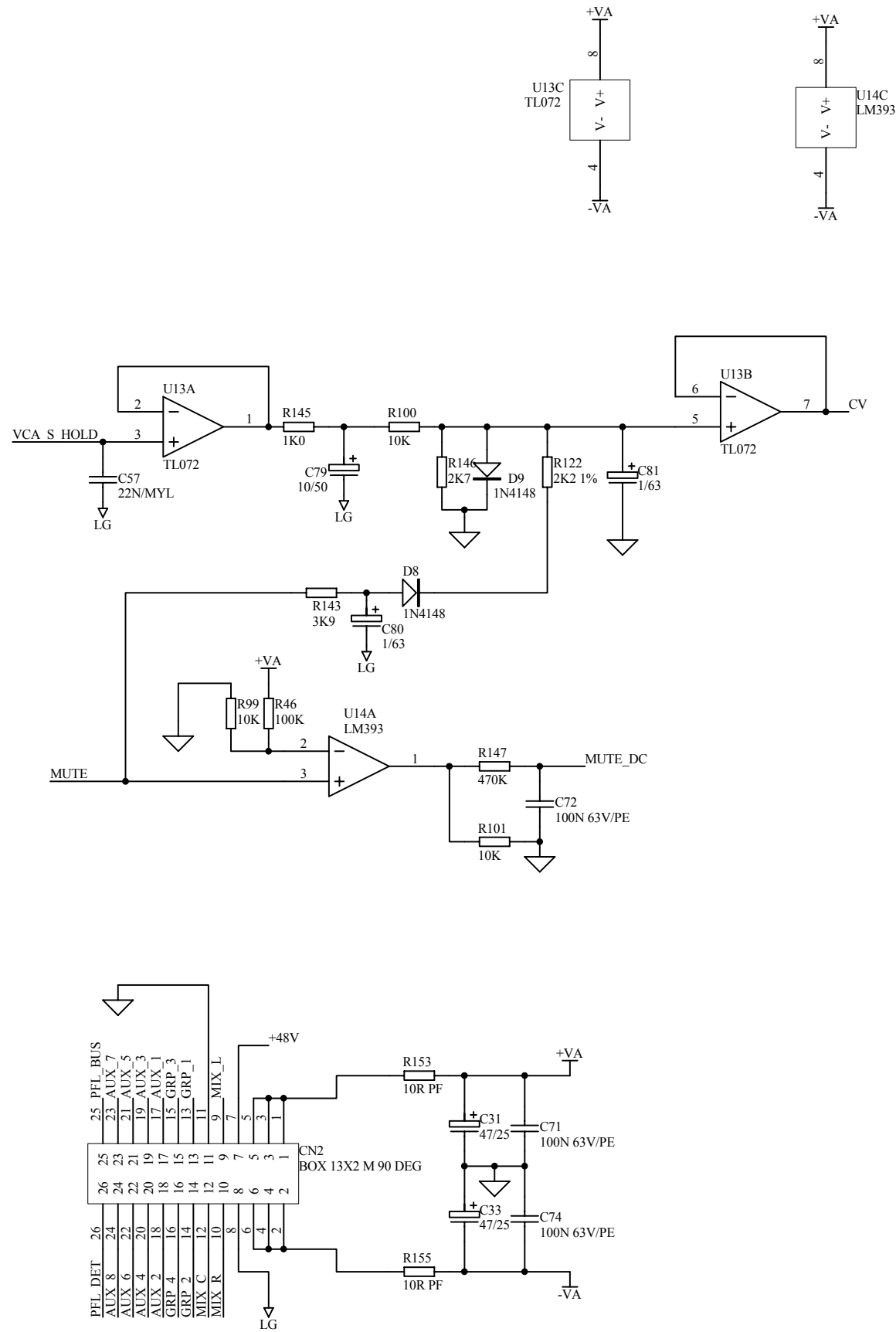

**ALLEN&HEATH**  
 Kernick Industrial Estate,  
 Penryn, Cornwall,  
 England. TR10 9LU  
 Tel: +44 (0)8707 556250  
 Fax: +44 (0)8707 556251

ISSUE	BY	DATE

FILE: C4451\_2.1P3.Sch PRINTED: 13:58:10 12-Dec-2001

TITLE: ML3000 STEREO INPUT  
 PAGE:  
 DRG No: 4451 ISSUE: 2.1 SHEET: 3 OF 3



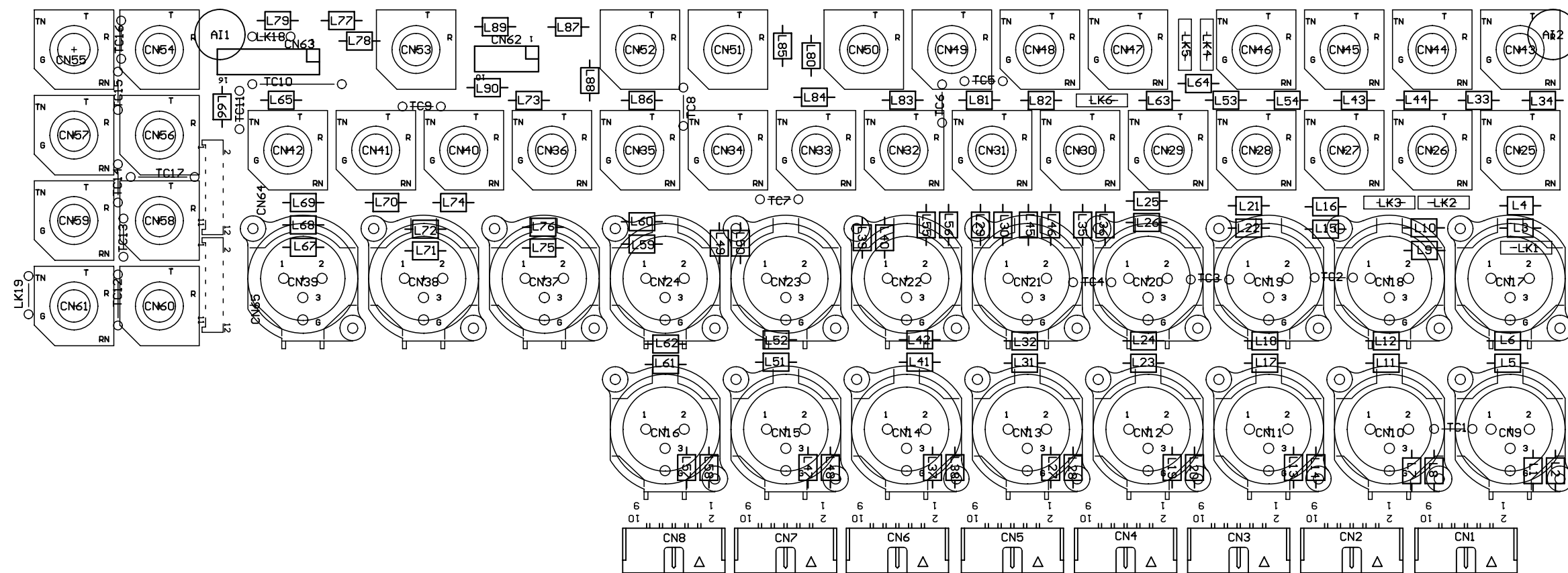

**ALLEN & HEATH**

Kernick Industrial Estate,  
Penryn, Cornwall,  
England, TR10 9LU

Tel: +44 (0)8707 556250  
Fax: +44 (0)8707 556251

.GTO

FILE: AG4456.PCB

PRINTED: 14:35:43 12-Dec-2001

TITLE: ML3000 MASTER CONNECTOR PCB

DRG No: AG4456 ISSUE: 1

ALLEN&HEATH ML3000 SERVICE MANUAL

**D8**

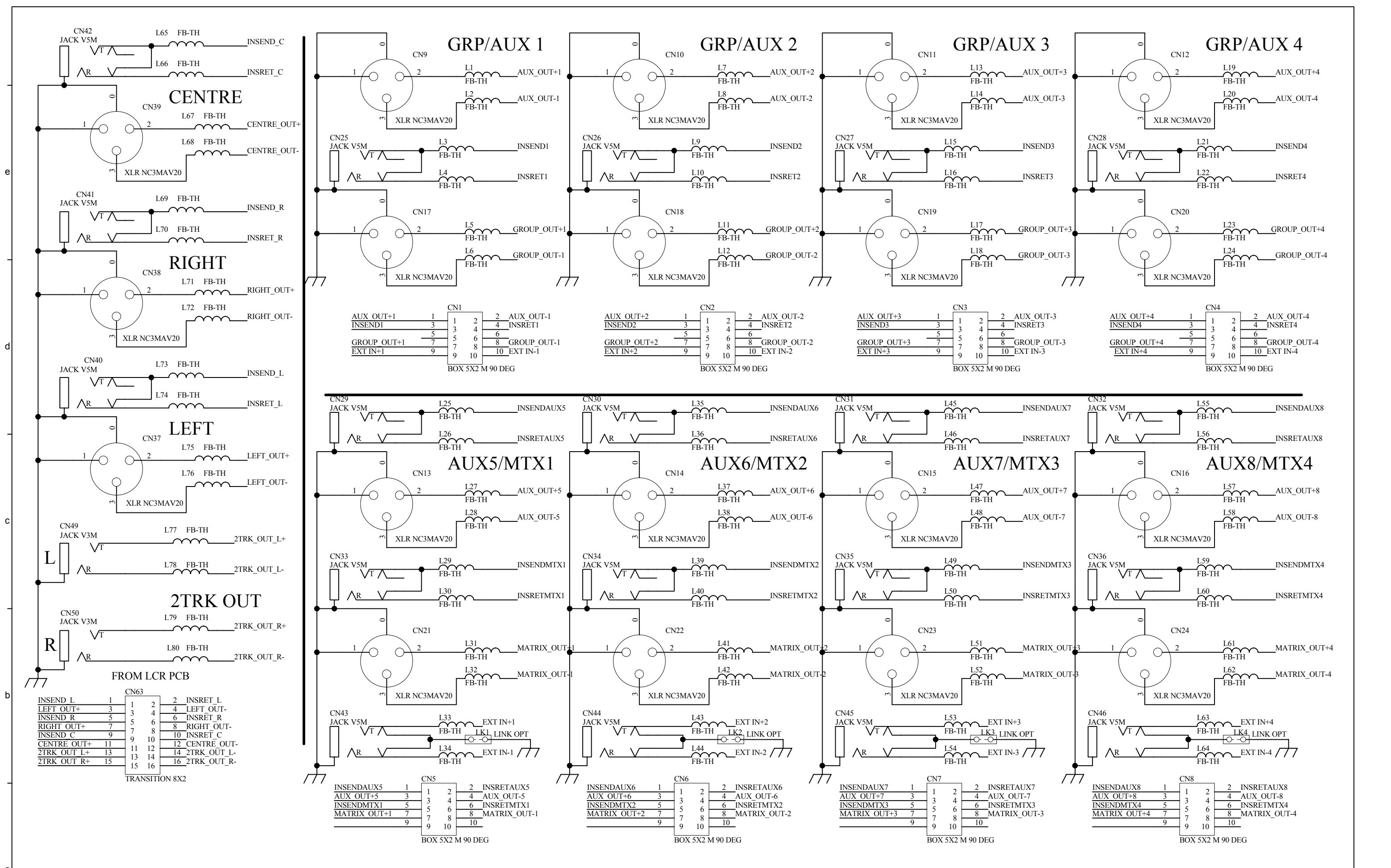

**ALLEN&HEATH**  
 Kernick Industrial Estate,  
 Penryn, Cornwall,  
 England. TR10 9LU  
 Tel: +44 (0)8707 556250  
 Fax: +44 (0)8707 556251

ISSUE	BY	DATE
A 1	SRT DWD	07-06-01 14-01-02

FILE: C4456_AP1.Sch	PRINTED: 10:46:57	14-Jan-2002
---------------------	-------------------	-------------

TITLE: **ML3000 MASTER CONNECTOR PCB**  
 PAGE:  
 DRG No: **C4456** ISSUE: 1 SHEET: 2 OF 3

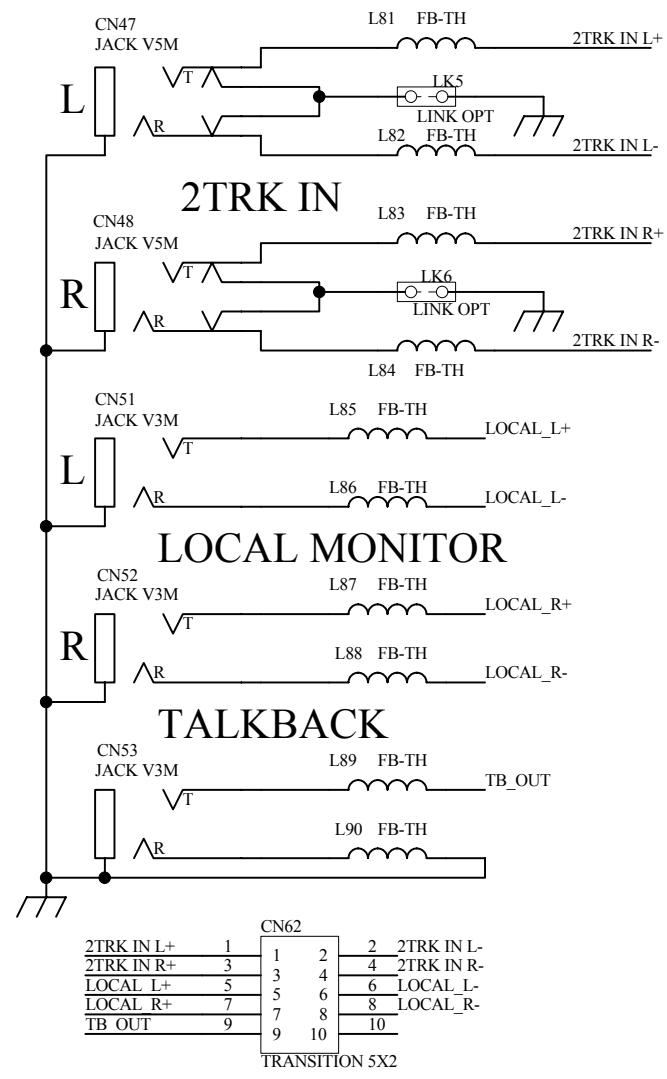

2TRK IN L+	1	2	2TRK IN L-
2TRK IN R+	3	4	2TRK IN R-
LOCAL L+	5	6	LOCAL L-
LOCAL R+	7	8	LOCAL R-
TB OUT	9	10	

TRANSITION 5X2

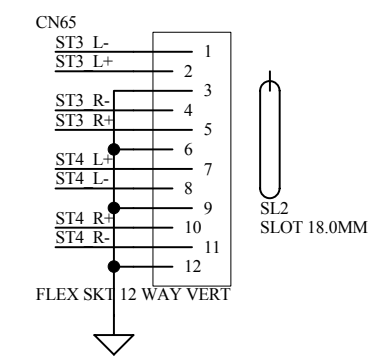
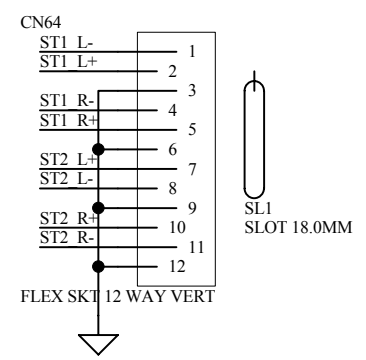
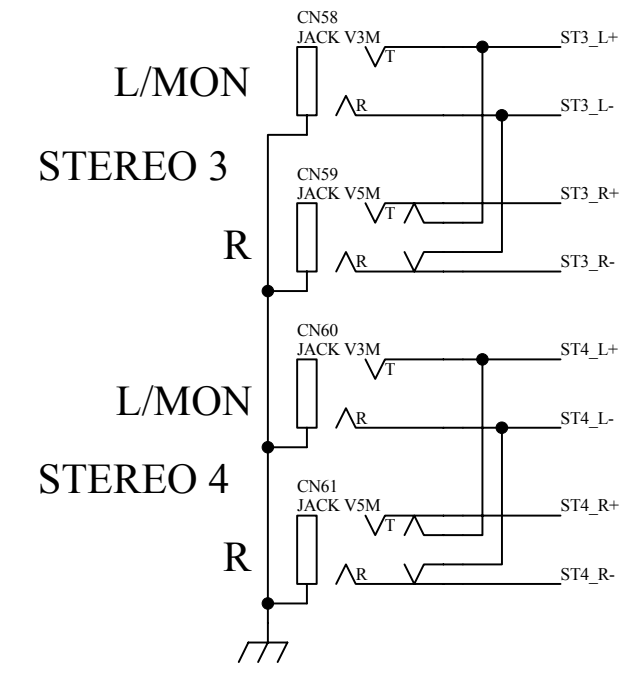
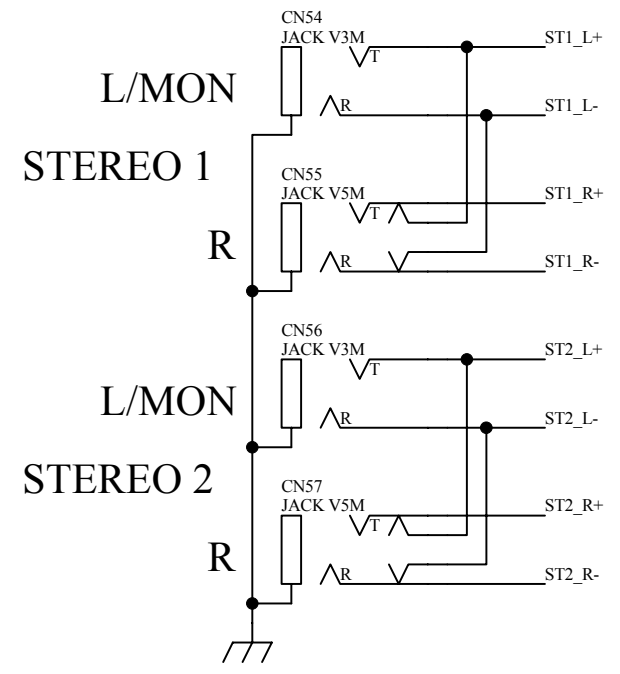

**ALLEN&HEATH**  
 Kernick Industrial Estate,  
 Penryn, Cornwall,  
 England. TR10 9LU  
 Tel: +44 (0)8707 556250  
 Fax: +44 (0)8707 556251

ISSUE	BY	DATE
A 1	SRT DWD	07-06-01 14-01-02

AI1 HOLE-AI      AI2 HOLE-AI

FILE: C4456\_AP2.Sch      PRINTED: 10:48:03 14-Jan-2002

TITLE: ML3000 MASTER CONNECTOR PCB  
 PAGE:  
 DRG No: C4456      ISSUE: 1      SHEET: 3 OF 3

e  
d  
c  
b  
a

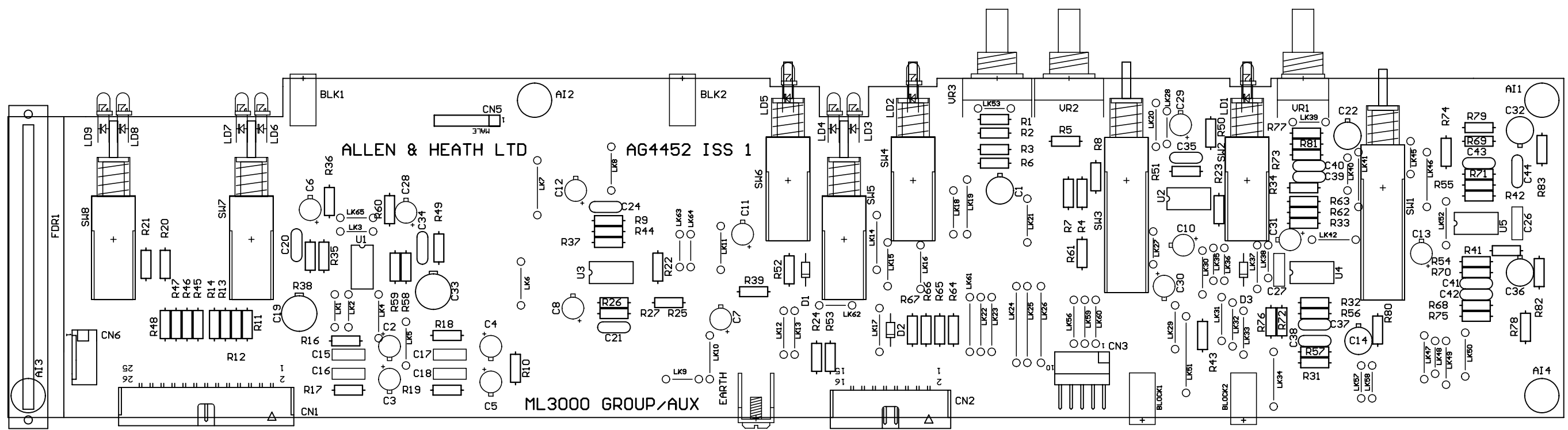

**ALLEN & HEATH**  
 Kernick Industrial Estate,  
 Penryn, Cornwall,  
 England. TR10 9LU  
 Tel: +44 (0)8707 556250  
 Fax: +44 (0)8707 556251

.GTO

FILE: AG4452\_1.PCB

PRINTED: 16:01:14 12-Dec-2001

TITLE: ML3000 GROUP/AUX PCB

DRG No: AG4452 ISSUE: 1

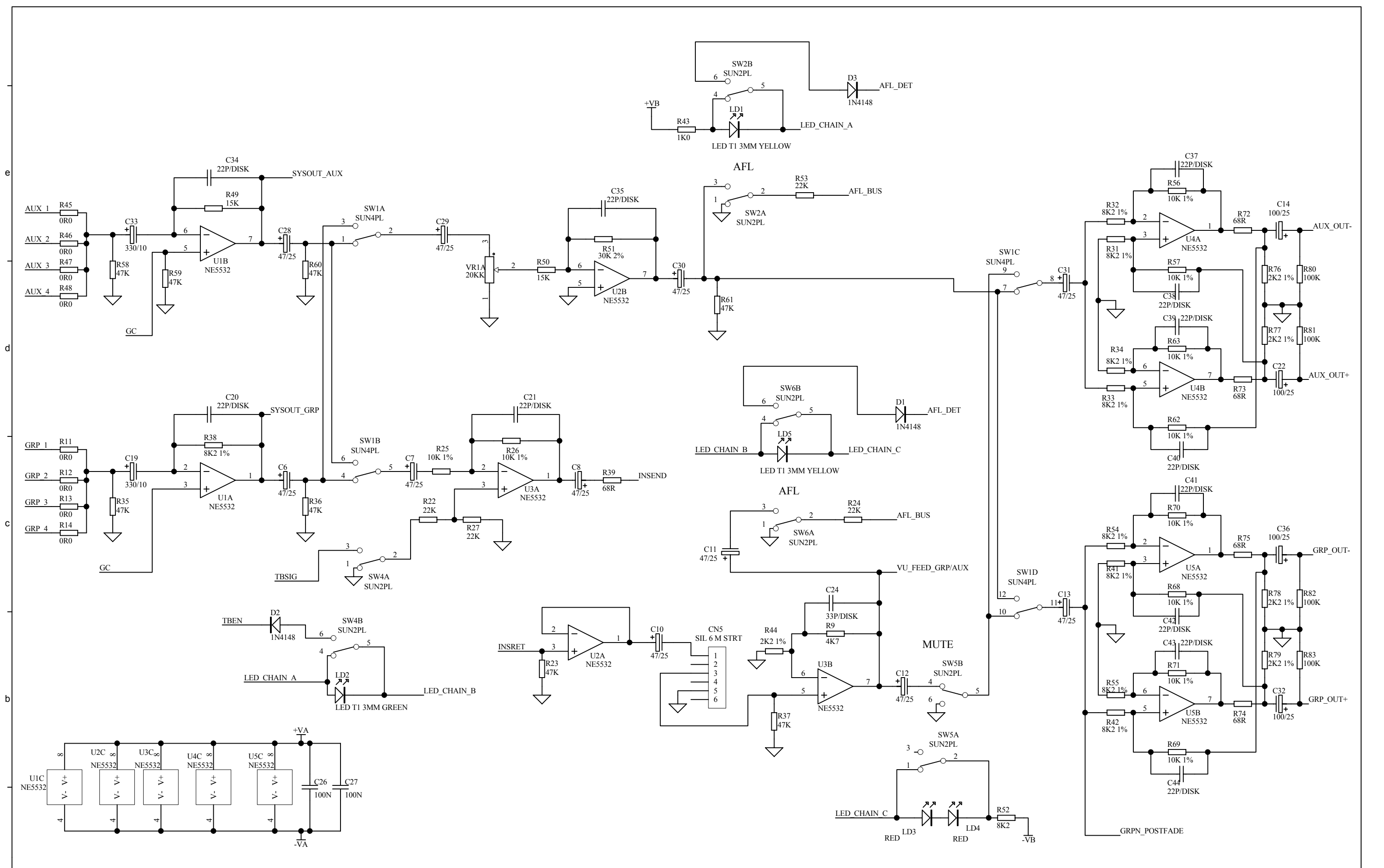

<b>ALLEN&amp;HEATH</b> Kernick Industrial Estate, Penryn, Cornwall, England. TR10 9LU Tel: +44 (0)8707 556250 Fax: +44 (0)8707 556251	ISSUE	BY	DATE		FILE: C4452_1P1.Sch PRINTED: 14:56:50 4-Jan-2002

TITLE: <b>ML3000 GROUP/AUX</b>
PAGE:
DRG No: <b>C4452</b> ISSUE: 1    SHEET: 1 OF 2

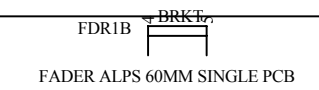
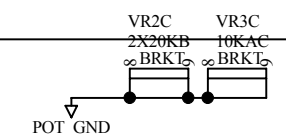
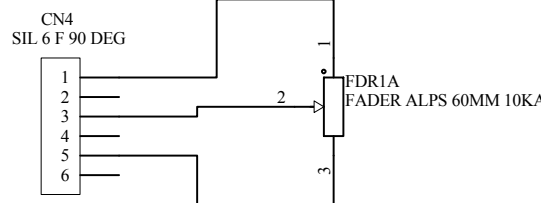
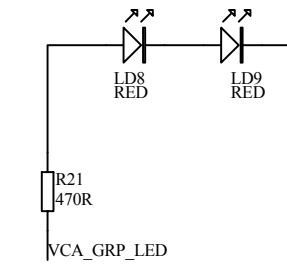
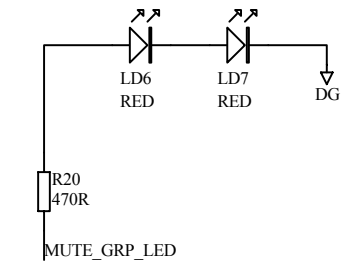
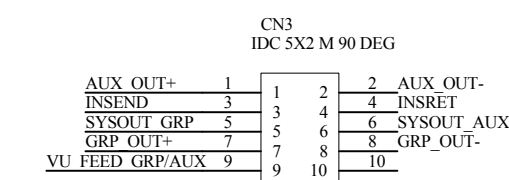
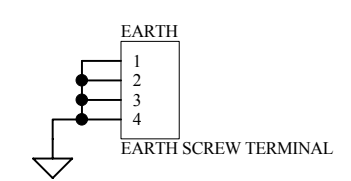
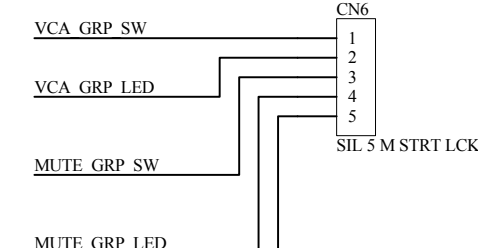
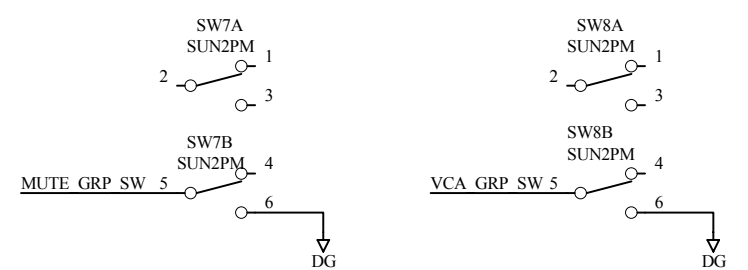
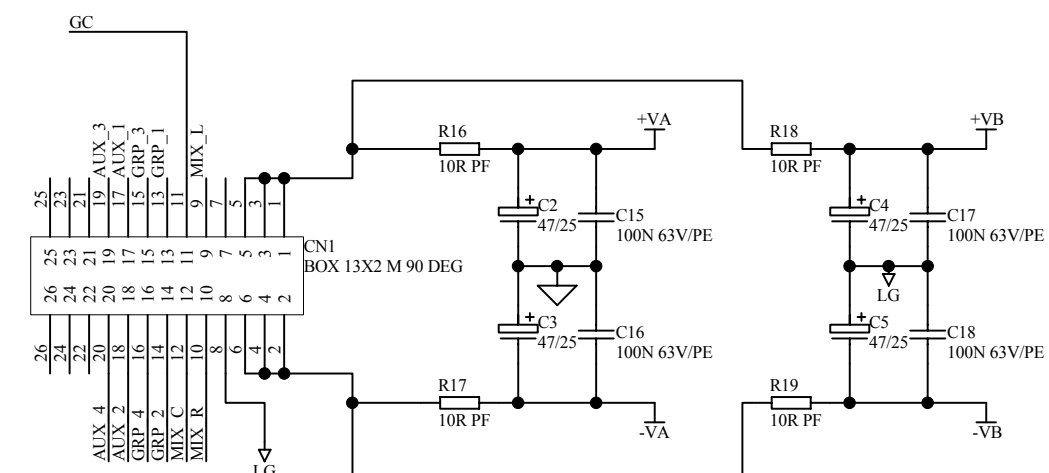
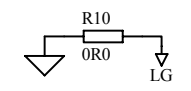
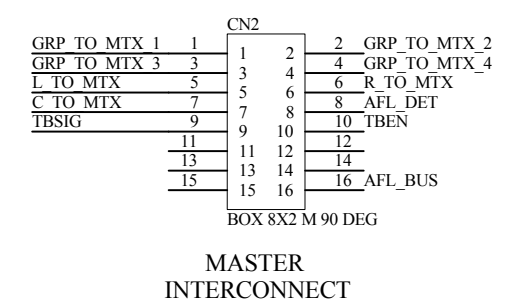
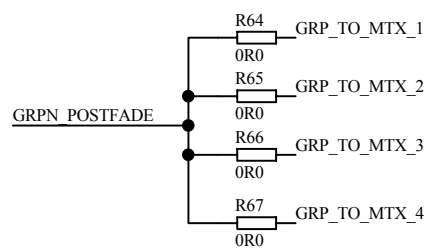
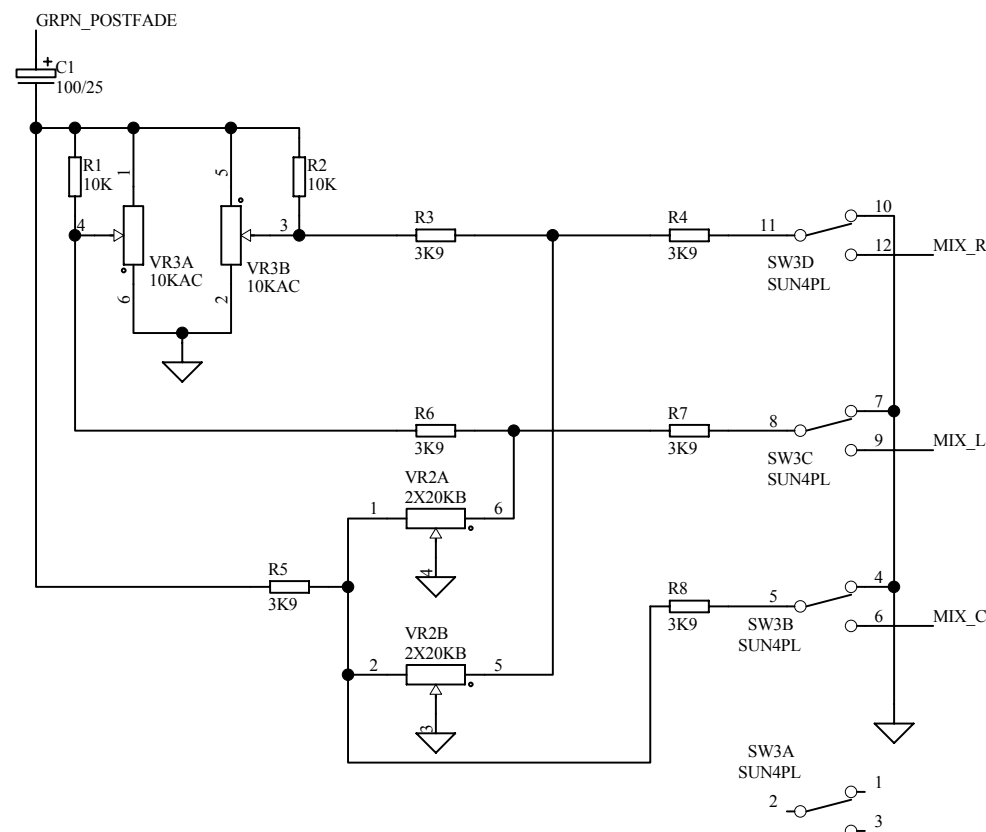

**ALLEN&HEATH**  
 Kernick Industrial Estate,  
 Penryn, Cornwall,  
 England. TR10 9LU  
 Tel: +44 (0)8707 556250  
 Fax: +44 (0)8707 556251

ISSUE	BY	DATE

FILE: C4452\_1P2.Sch PRINTED: 15:09:10 4-Jan-2002

TITLE: ML3000 GROUP/AUX  
 PAGE:

DRG No: C4452 ISSUE: 1 SHEET: 2 OF 2

e  
d  
c  
b  
a

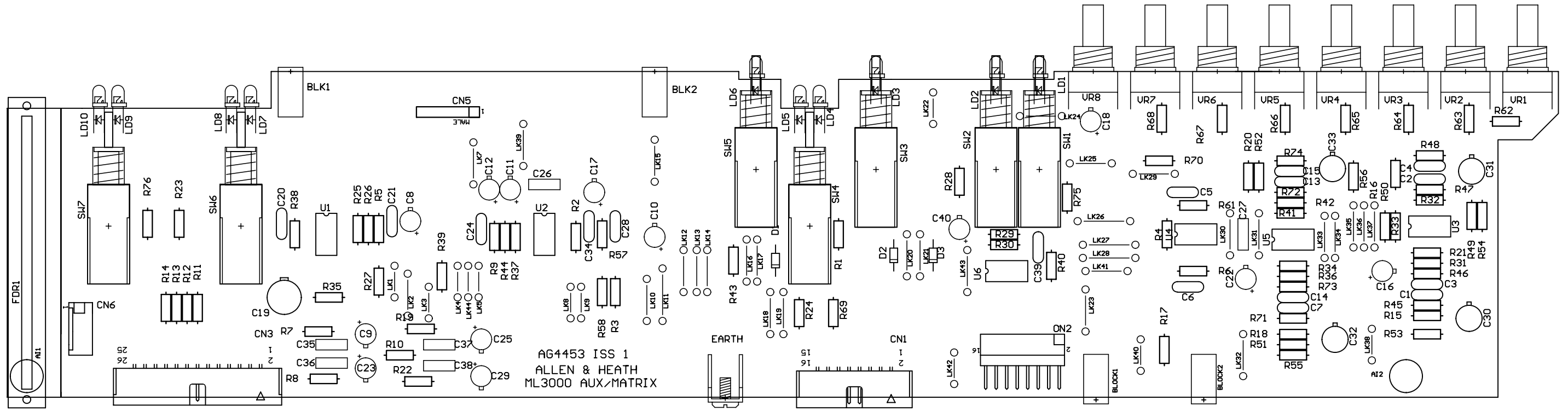

AG4453 ISS 1  
ALLEN & HEATH  
ML3000 AUX/MATRIX

**ALLEN & HEATH**  
Kernick Industrial Estate,  
Penryn, Cornwall,  
England. TR10 9LU  
Tel: +44 (0)8707 556250  
Fax: +44 (0)8707 556251

.GTO

FILE: AG4453\_1.PCB      PRINTED: 15:54:44 4-Jan-2002

TITLE: **ML3000 AUX/MATRIX**

DRG No: **AG4453** ISSUE: 1

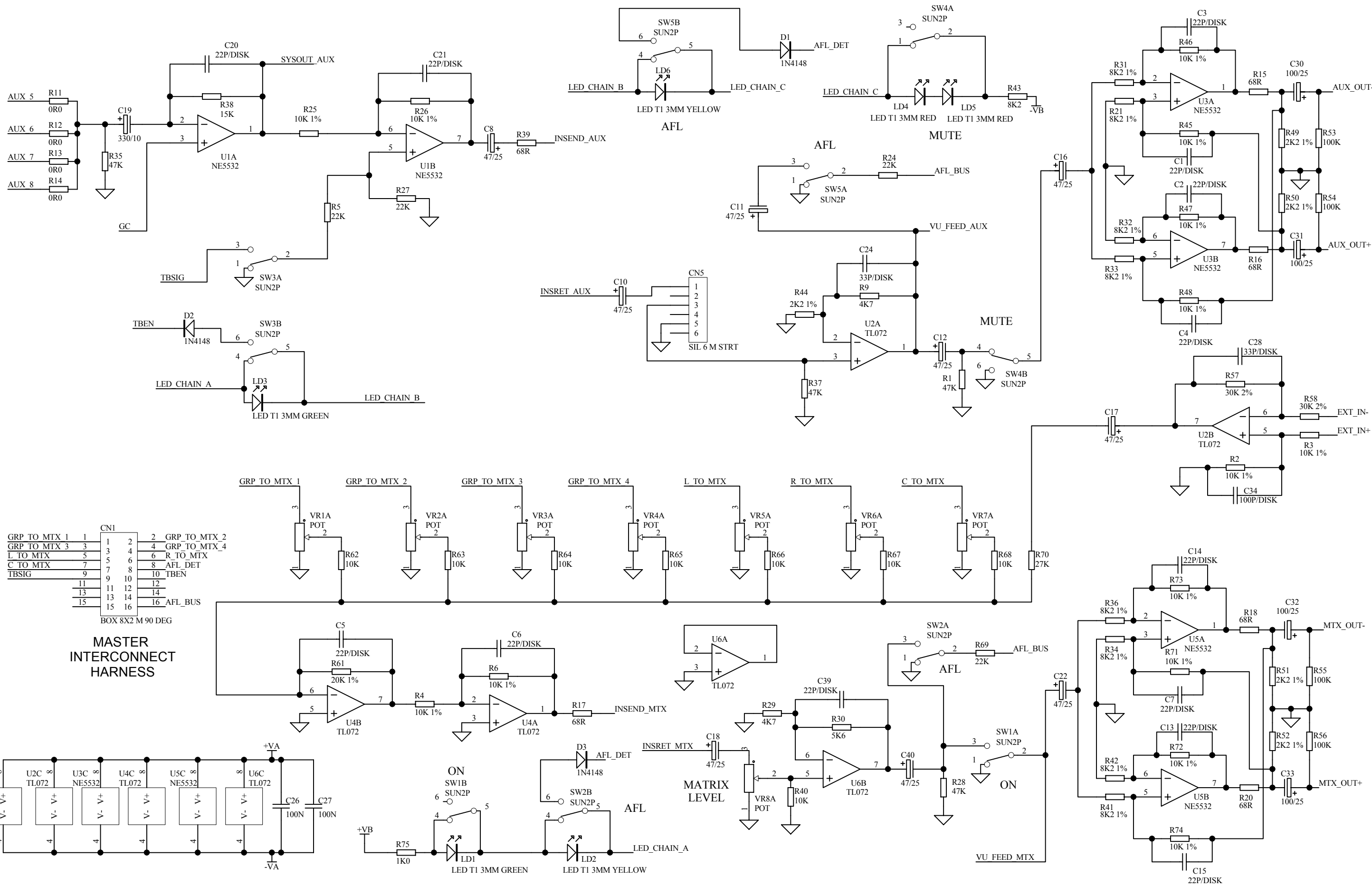

**ALLEN&HEATH**  
 Kernick Industrial Estate,  
 Penryn, Cornwall,  
 England. TR10 9LU  
 Tel: +44 (0)8707 556250  
 Fax: +44 (0)8707 556251

ISSUE	BY	DATE
1.1	DWD	11-01-02

VR1B 20K	VR2B 20K	VR3B 20K	VR4B 20K	VR5B 20K	VR6B 20K	VR7B 20K	VR8B 20K
FILE: C4453_1P1.Sch		PRINTED: 16:27:21 11-Jan-2002					

TITLE: <b>ML3000 AUX/MATRIX</b>
PAGE:
DRG No: <b>C4453</b> ISSUE: 1.1 SHEET: 1 OF 2



CN2 IDC 8X2 M 90 DEG				
INSEND_AUX	1	1	2	INSRET_AUX
AUX_OUT+	3	3	4	AUX_OUT-
INSEND_MTX	5	5	6	INSRET_MTX
MTX_OUT+	7	7	8	MTX_OUT-
EXT_IN+	9	9	10	EXT_IN-
VU_FEED_AUX	11	11	12	VU_FEED_MTX
	13	13	14	SYSOUT_AUX
	15	15	16	

TO MASTER DISTRIBUTION  
PCB

60MM FADER CONNECTOR

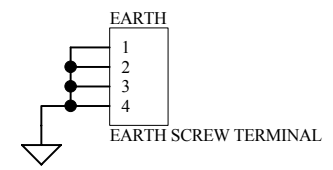
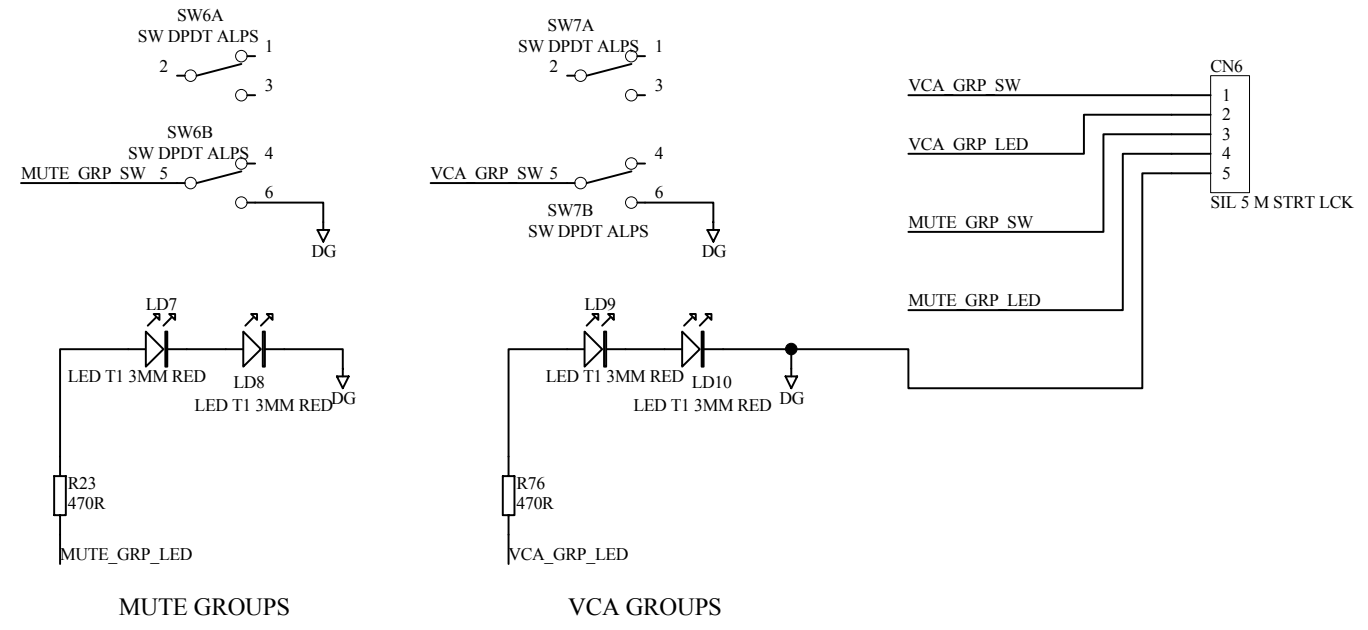
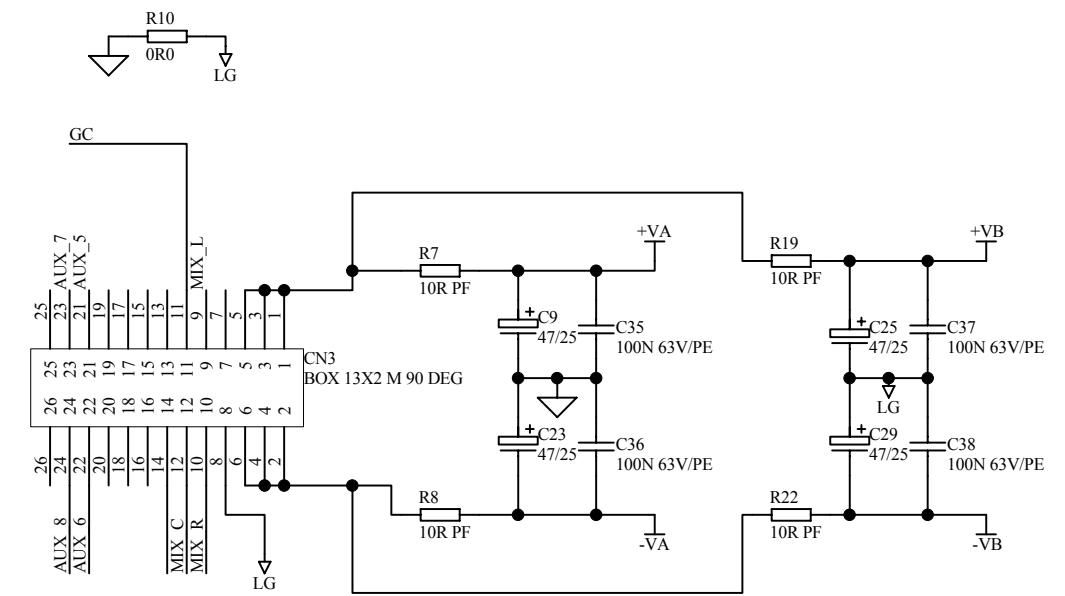
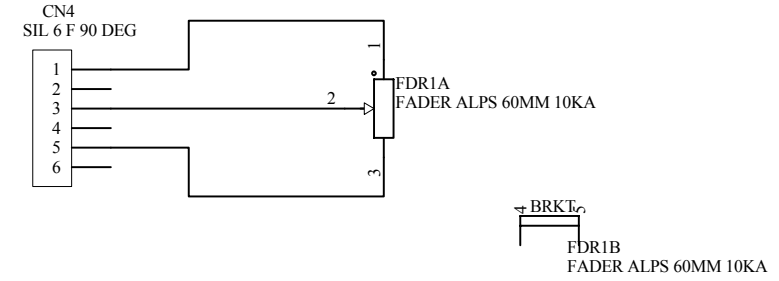

<b>ALLEN&amp;HEATH</b> Kernick Industrial Estate, Penryn, Cornwall, England. TR10 9LU Tel: +44 (0)8707 556250 Fax: +44 (0)8707 556251	ISSUE	BY	DATE
	1.1	DWD	11-01-02

FILE: C4453\_1P2.Sch PRINTED: 16:28:31 11-Jan-2002

TITLE: ML3000 AUX/MATRIX
PAGE:
DRG No: C4453 ISSUE: 1.1 SHEET: 2 OF 2

e  
d  
c  
b  
a

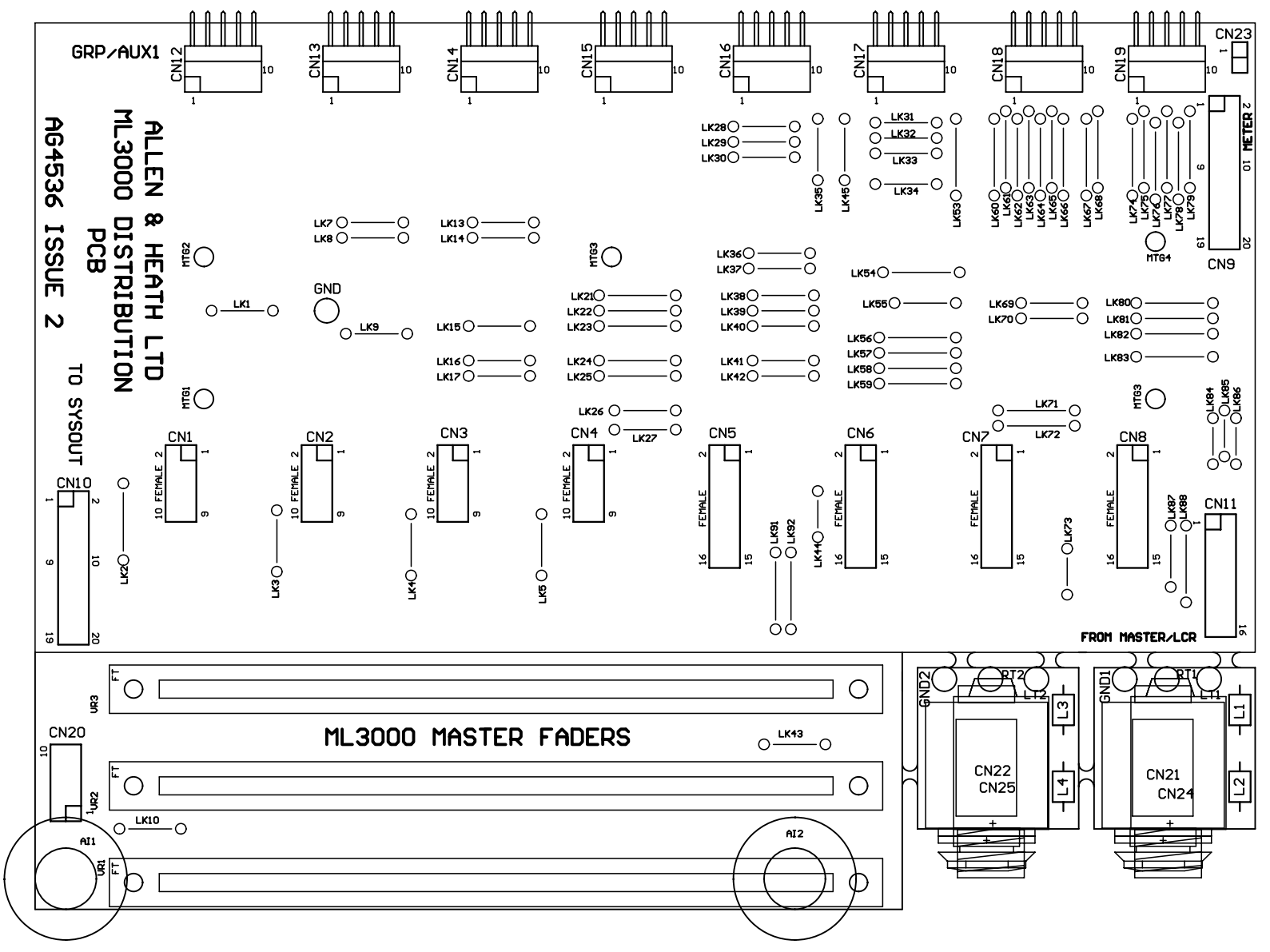

**ALLEN & HEATH**  
 Kernick Industrial Estate,  
 Penryn, Cornwall,  
 England, TR10 9LU  
 Tel: +44 (0)8707 556250  
 Fax: +44 (0)8707 556251

FILE: AG4536\_2.PCB PRINTED: 16:21:54 4-Jan-2002

TITLE: ML3000 MASTER DISTRIBUTION

DRG No: AG4536 ISSUE: 2

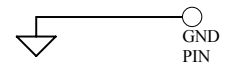
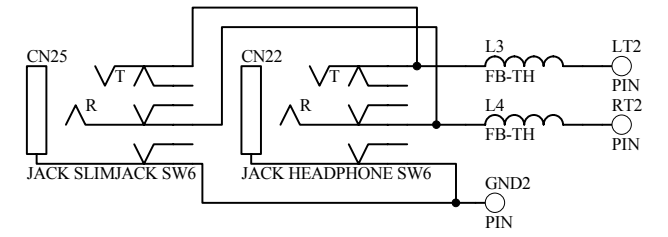
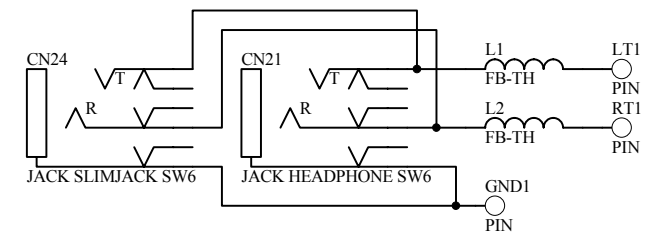
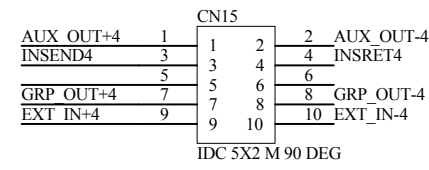
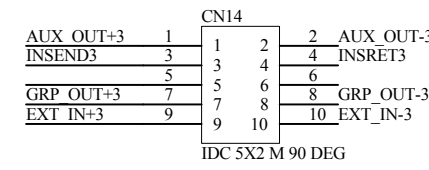
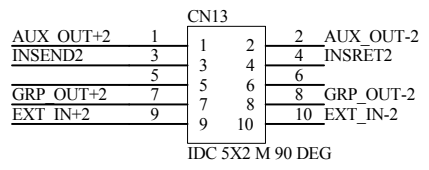
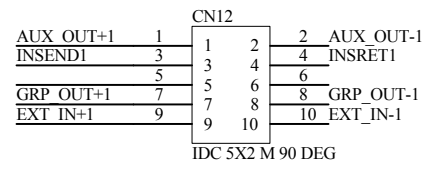

FROM LCR & MASTER PCB'S

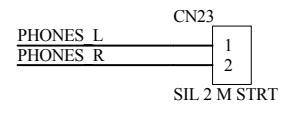
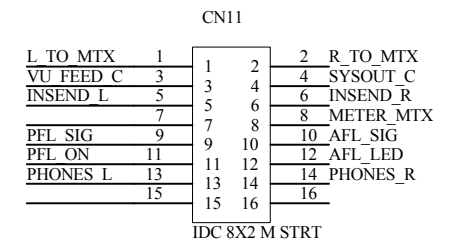

TO METERPOD

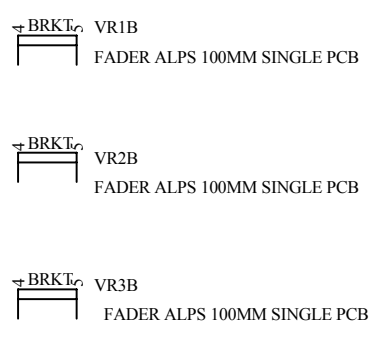
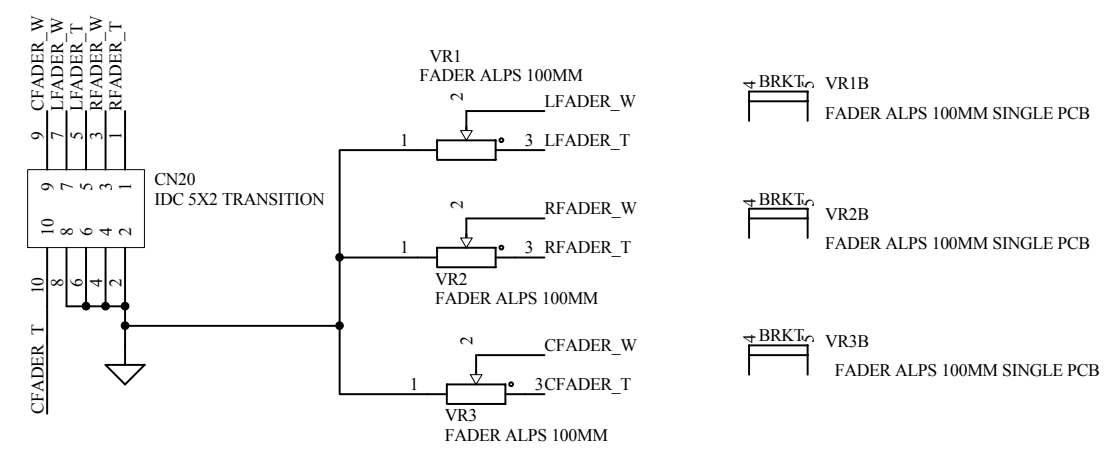
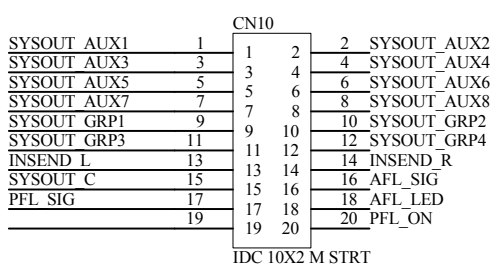
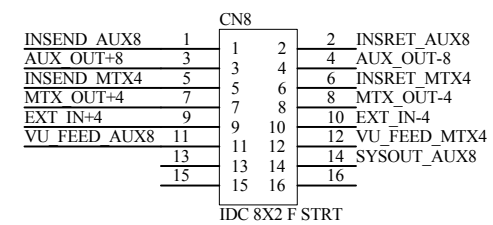
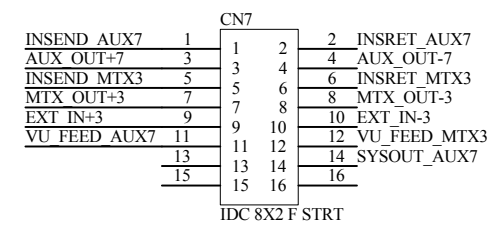
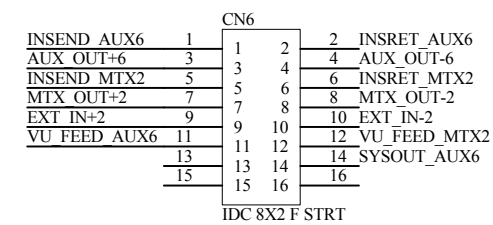
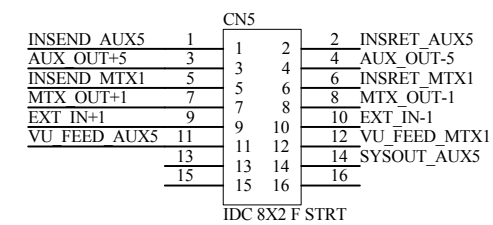
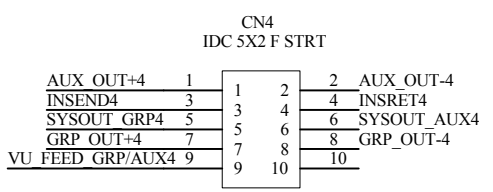
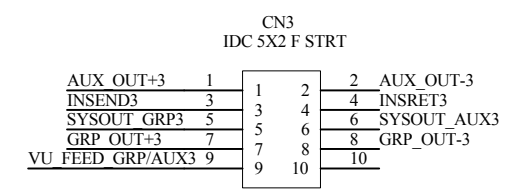
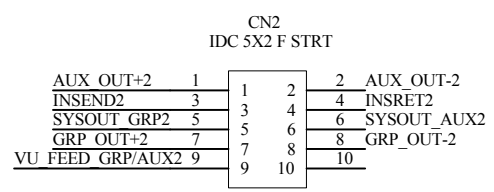
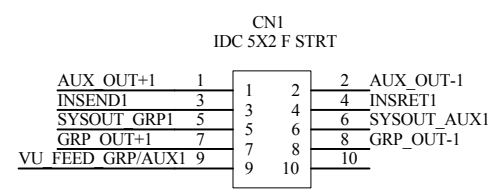
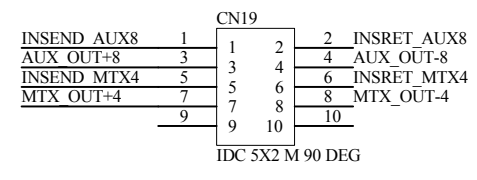
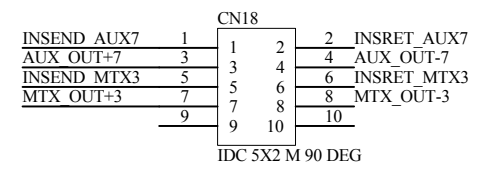
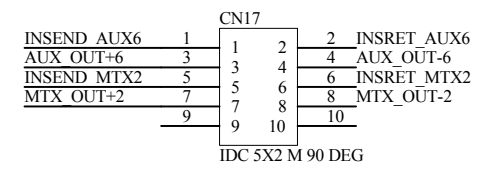
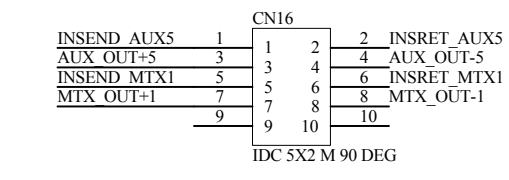
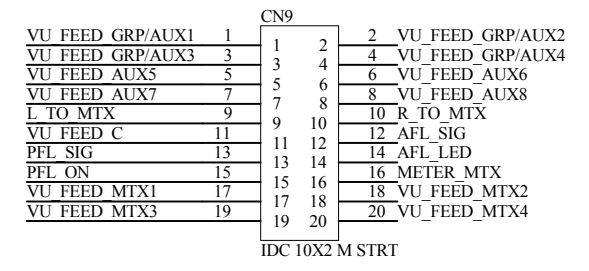

**ALLEN&HEATH**  
Kernick Industrial Estate,  
Penryn, Cornwall,  
England. TR10 9LU  
Tel: +44 (0)8707 556250  
Fax: +44 (0)8707 556251

ISSUE	BY	DATE

FILE: C4536_2.Sch	PRINTED: 11:41:34 11-Jan-2002
-------------------	-------------------------------

TITLE: ML3000 MASTER DISTRIBUTION PCB		
PAGE:		
DRG No: 4536	ISSUE: 2	SHEET: 1 OF 1

e  
d  
c  
b  
a

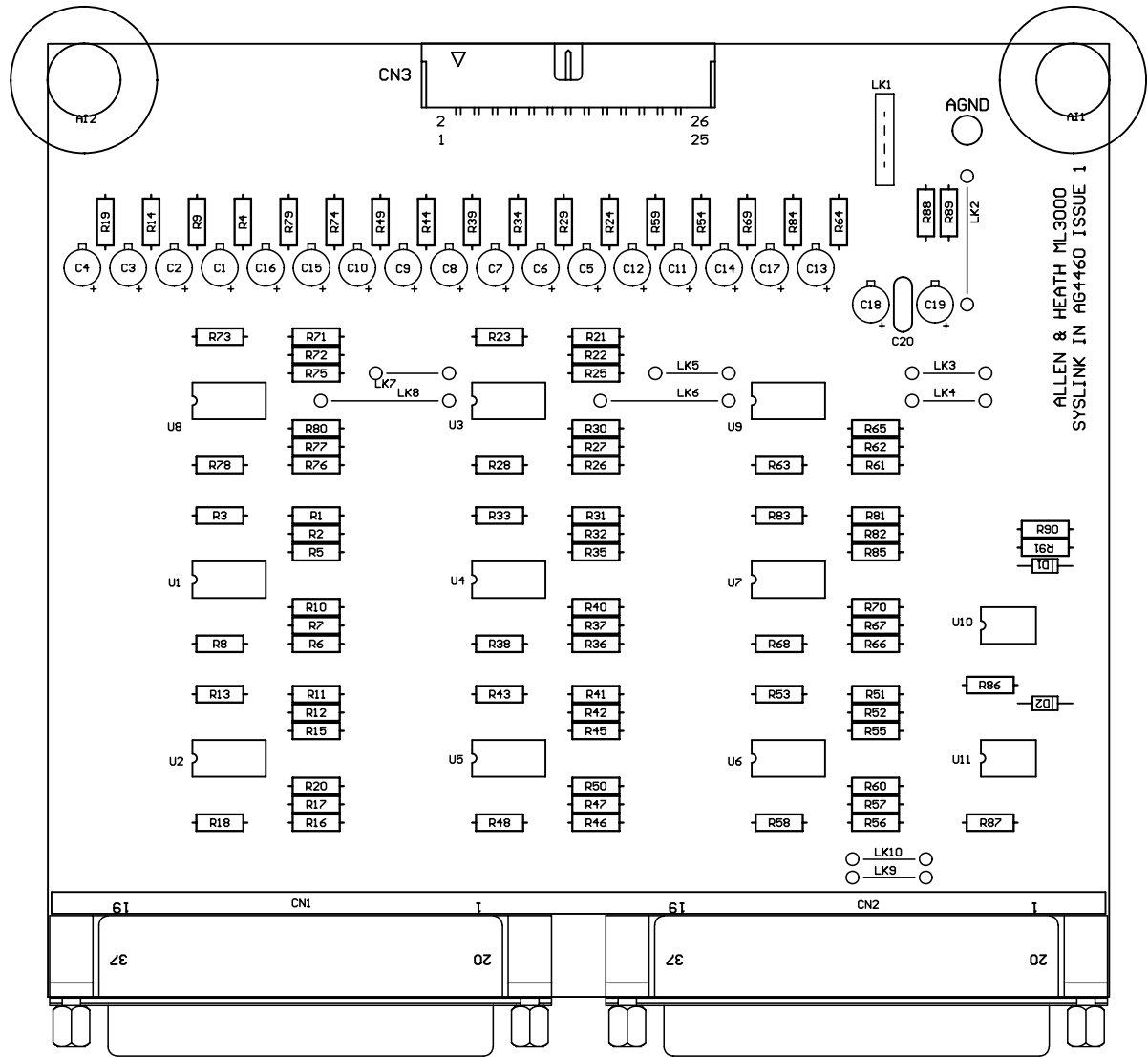

**ALLEN & HEATH**  
 Kernick Industrial Estate,  
 Penryn, Cornwall,  
 England. TR10 9LU  
 Tel: +44 (0)8707 556250  
 Fax: +44 (0)8707 556251

TOP OVERLAY .GTO  
 FILE: AG4460\_1.PCB  
 PRINTED: 14:21:21 8-Jan-2002

TITLE: ML3000 SYSLINK IN  
 DRG No: AG4460 ISSUE: 1

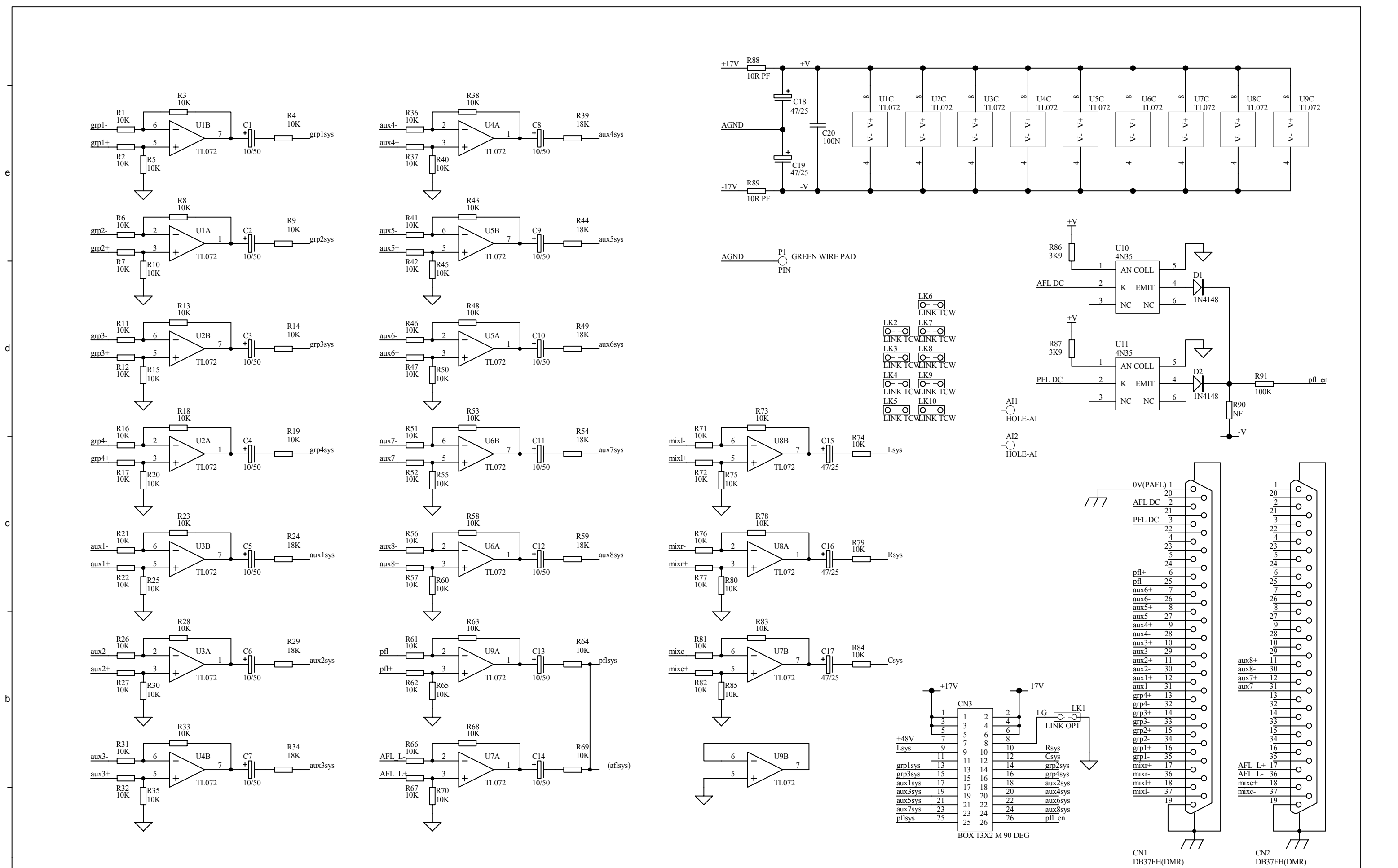

**ALLEN&HEATH**  
 Kernick Industrial Estate,  
 Penryn, Cornwall,  
 England. TR10 9LU  
 Tel: +44 (0)8707 556250  
 Fax: +44 (0)8707 556251

ISSUE	BY	DATE
A	JB	10/7/01
B	JB	21/8/01
1	AAT	08-01-02

PCB PROFILE CHANGED TO MAKE SPACE FOR NEW MIDI PWR PCB  
 VALUE CHANGES AND 1 TRACK CHANGE

FILE: C4460\_1.Sch      PRINTED: 14:23:46    8-Jan-2002

TITLE: **ML3000 SYSLINK IN**  
 PAGE:  
 DRG No: **AG4460**    ISSUE: 1    SHEET: 1 OF 1

e  
d  
c  
b  
a

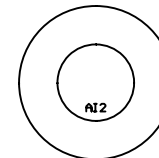
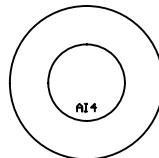
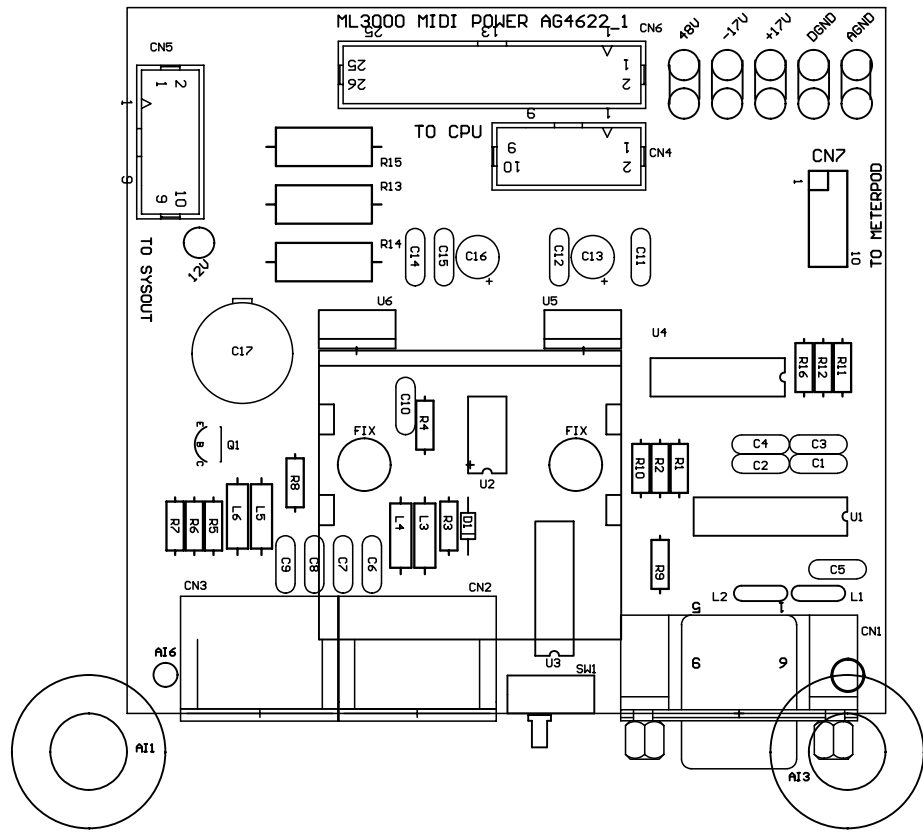

**ALLEN&HEATH**  
 Kernick Industrial Estate,  
 Penryn, Cornwall,  
 England, TR10 9LU  
 Tel: +44 (0)8707 556250  
 Fax: +44 (0)8707 556251

TOP OVERLAY .GTO

FILE: AG4622\_1.1.PCB

PRINTED: 16:09:02 7-Jan-2002

TITLE: ML3000 MIDI POWER PCB

DRG No: AG4622 ISSUE: 1

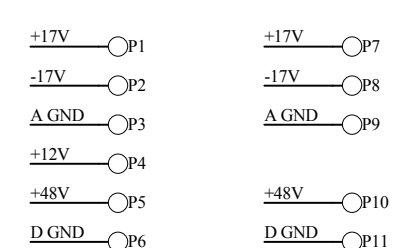
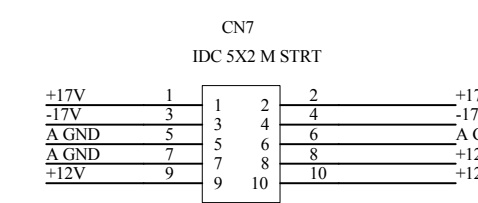
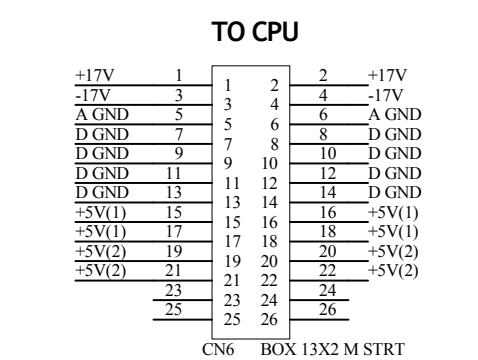
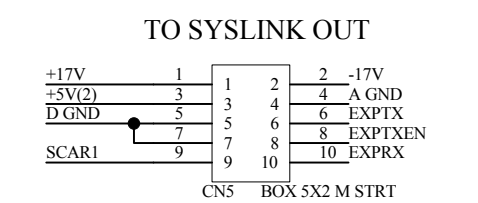
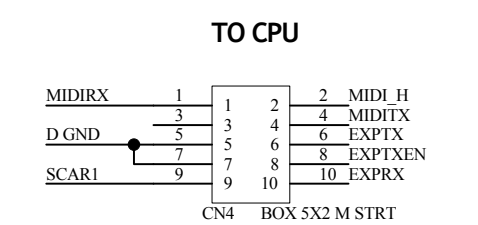
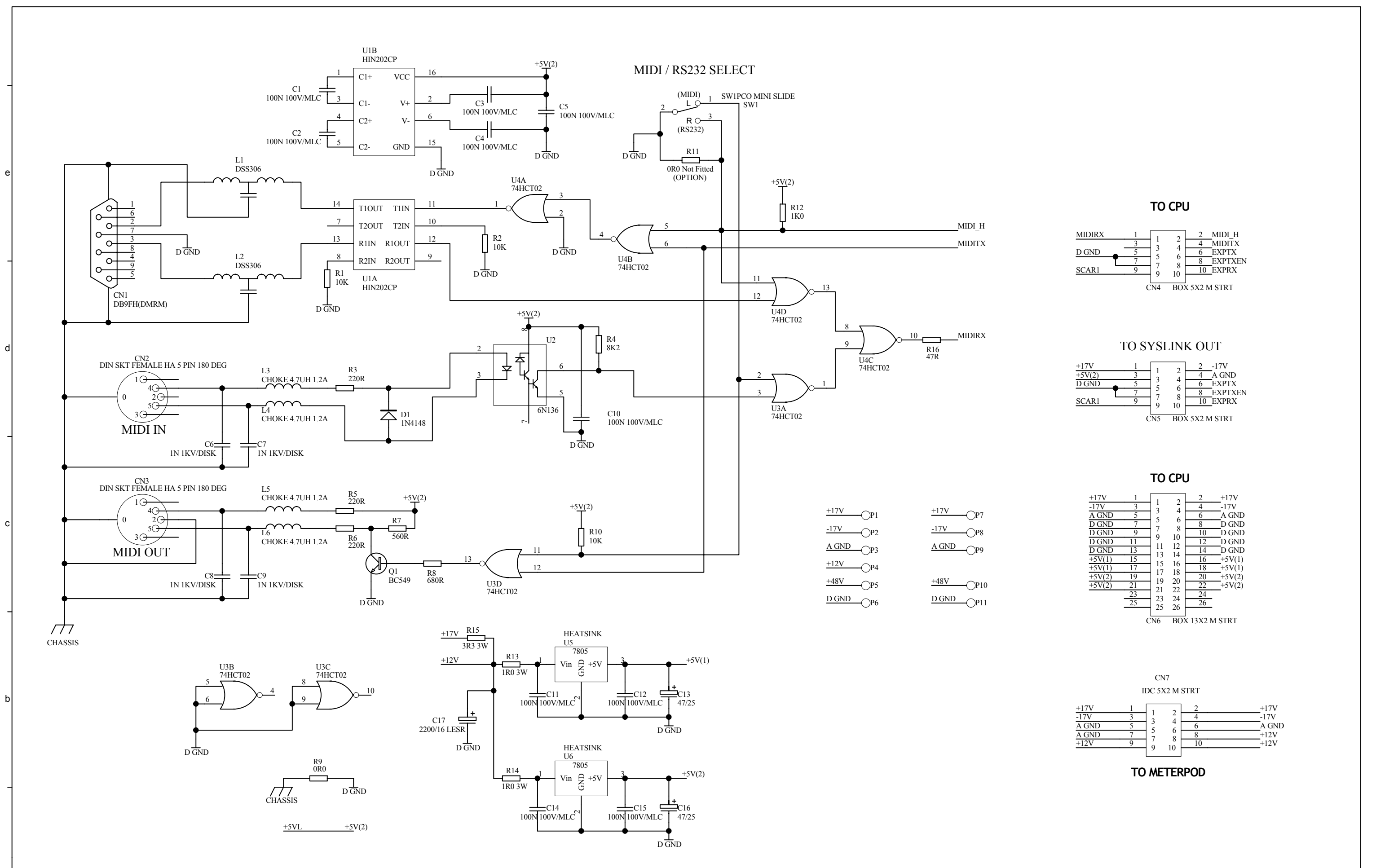

<b>ALLEN&amp;HEATH</b> Kernick Industrial Estate, Penryn, Cornwall, England. TR10 9LU Tel: +44 (0)8707 556250 Fax: +44 (0)8707 556251	ISSUE	BY	DATE	TITLE: ML3000 MIDI POWER PAGE: DRG No: AG4622 ISSUE: 1.2 SHEET: 1 OF 1
	A	JB	03/09/01	
	1	MG	05/10/01	
	1.1	AAT	27-10-01	
	1.2	DWD	11-01-02	
	FILE: C4622_1.2.Sch	PRINTED: 16:57:20	11-Jan-2002	

ML CPU PCB AG3718 issue 4

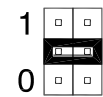
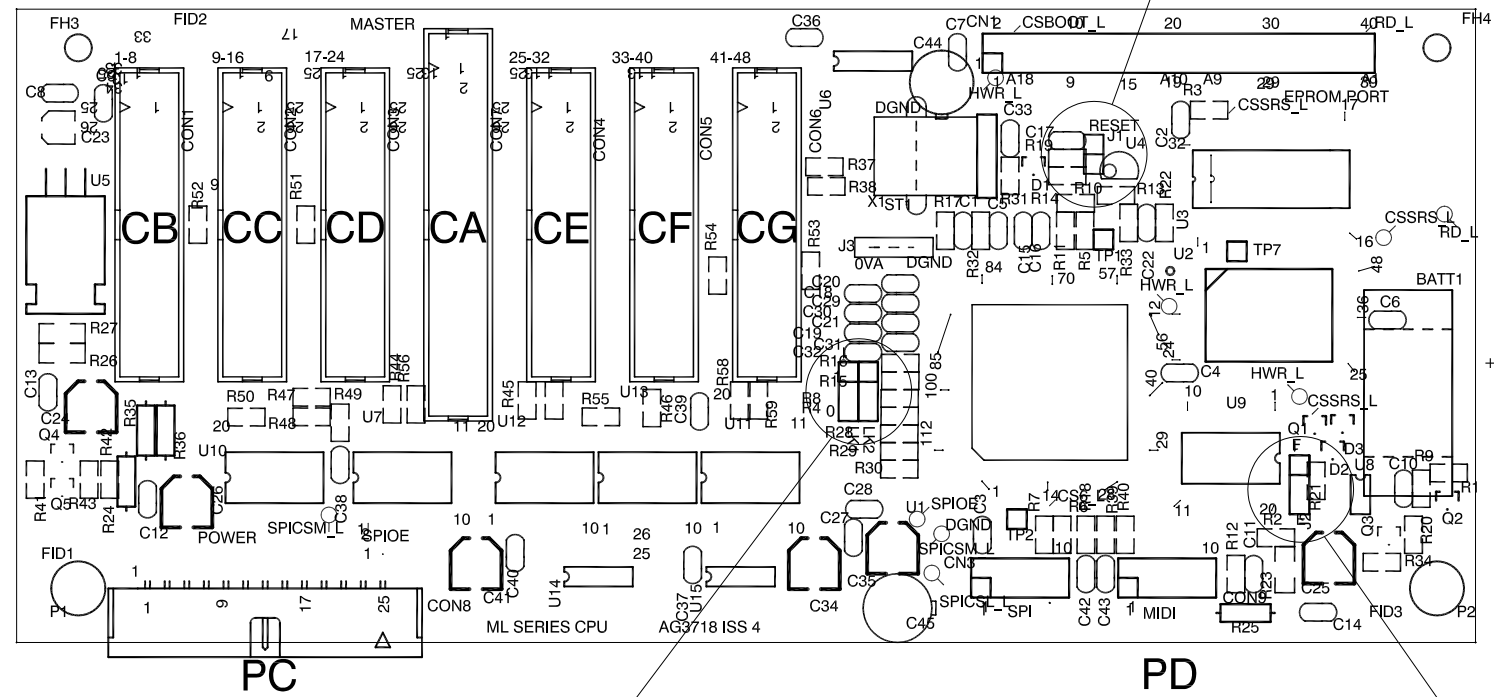

ML3000 CONSOLE

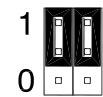

ML4000 SIDECAR

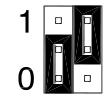

ML4000 CONSOLE

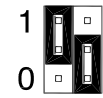

ML5000 SIDECAR

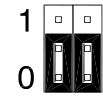

ML5000 CONSOLE

LK1  
LK2



FLASH (NORMAL)



EPROM (BOOT LOAD)

12

ASSIGN LINKS ACCORDING TO CONSOLE TYPE

**ALLEN & HEATH**

Kernick Industrial Estate,  
Penryn, Cornwall,  
England. TR10 9LU

Tel: +44 (0)8707 556250  
Fax: +44 (0)8707 556251

TOP OVERLAY

.GTO

TITLE: **ML SERIES CPU PCB**

DRG No: **AG3718** ISSUE: **4**

FILE: .Pcb\_File\_Name\_No\_Path

PRINTED: .Print\_Time .Print\_Date



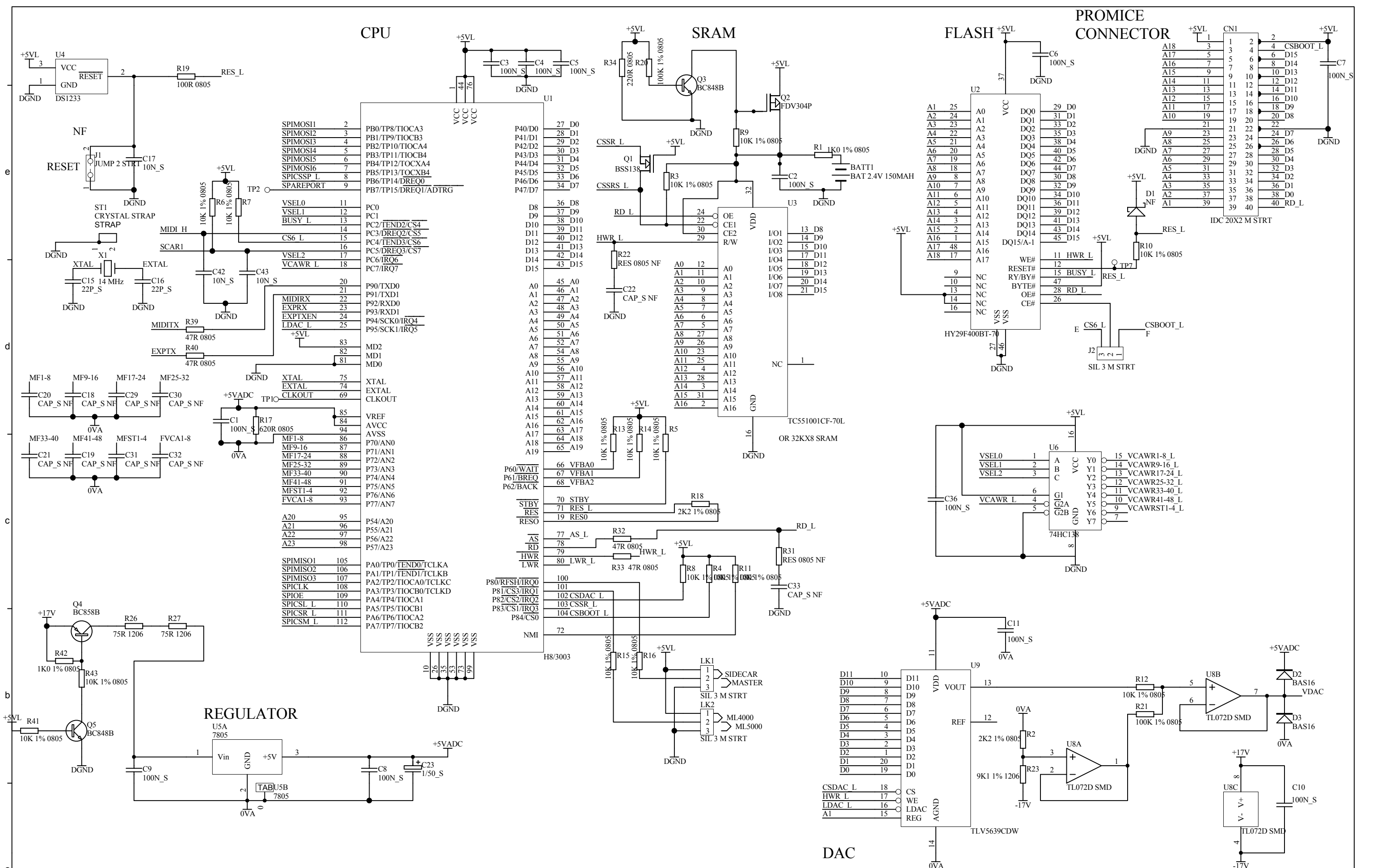

**ALLEN&HEATH**  
 Kernick Industrial Estate,  
 Penryn, Cornwall,  
 England. TR10 9LU  
 Tel: +44 (0)8707 556250  
 Fax: +44 (0)8707 556251

ISSUE	BY	DATE
ISS 3	AAT	07-12-00
ISS 3.1	AAT	26-01-01
ISS 3.2	AAT	26-10-01
ISS 4	AAT	20-11-01

FILE: AG3718\_4P2.SCH  
 PRINTED: 15:42:23 7-Jan-2002

TITLE: ML3/4/5000 CPU PCB  
 PAGE: CPU & MEMORY  
 DRG No: AG3718 ISSUE: 4 SHEET: 2 OF 4

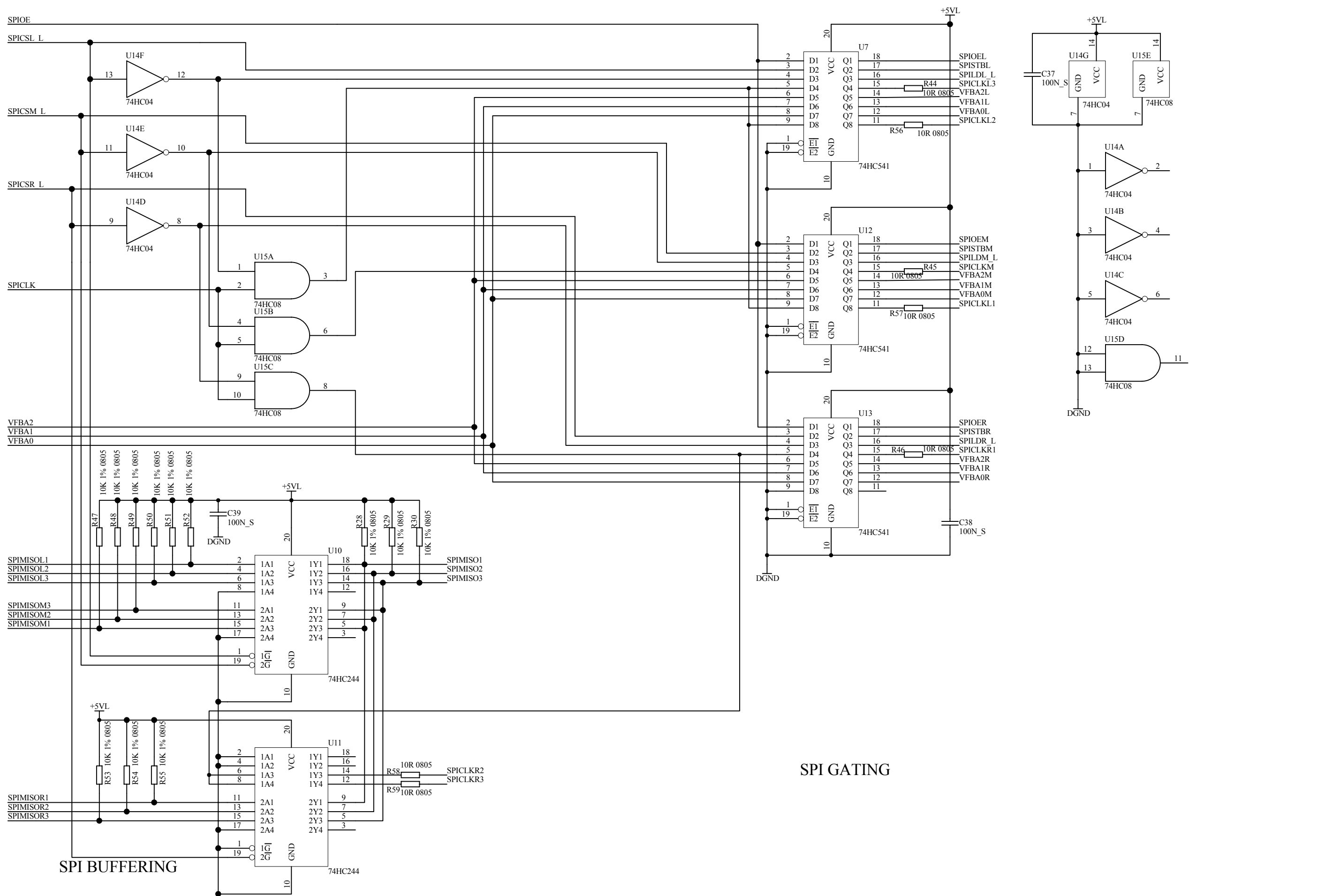

SPI GATING

SPI BUFFERING

**ALLEN&HEATH**  
 Kernick Industrial Estate,  
 Penryn, Cornwall,  
 England. TR10 9LU  
 Tel: +44 (0)8707 556250  
 Fax: +44 (0)8707 556251

ISSUE	BY	DATE
ISS 3	AAT	07-12-00
ISS 3.1	AAT	26-01-01
ISS 3.2	AAT	26-10-01
ISS 4	AAT	20-11-01

FILE: AG3718\_4P3.SCH

PRINTED: 15:43:06 7-Jan-2002

TITLE: ML3/4/5000 CPU PCB  
 PAGE: SPI & BUFFERING

DRG No: AG3718 ISSUE: 4 SHEET: 3 OF 4

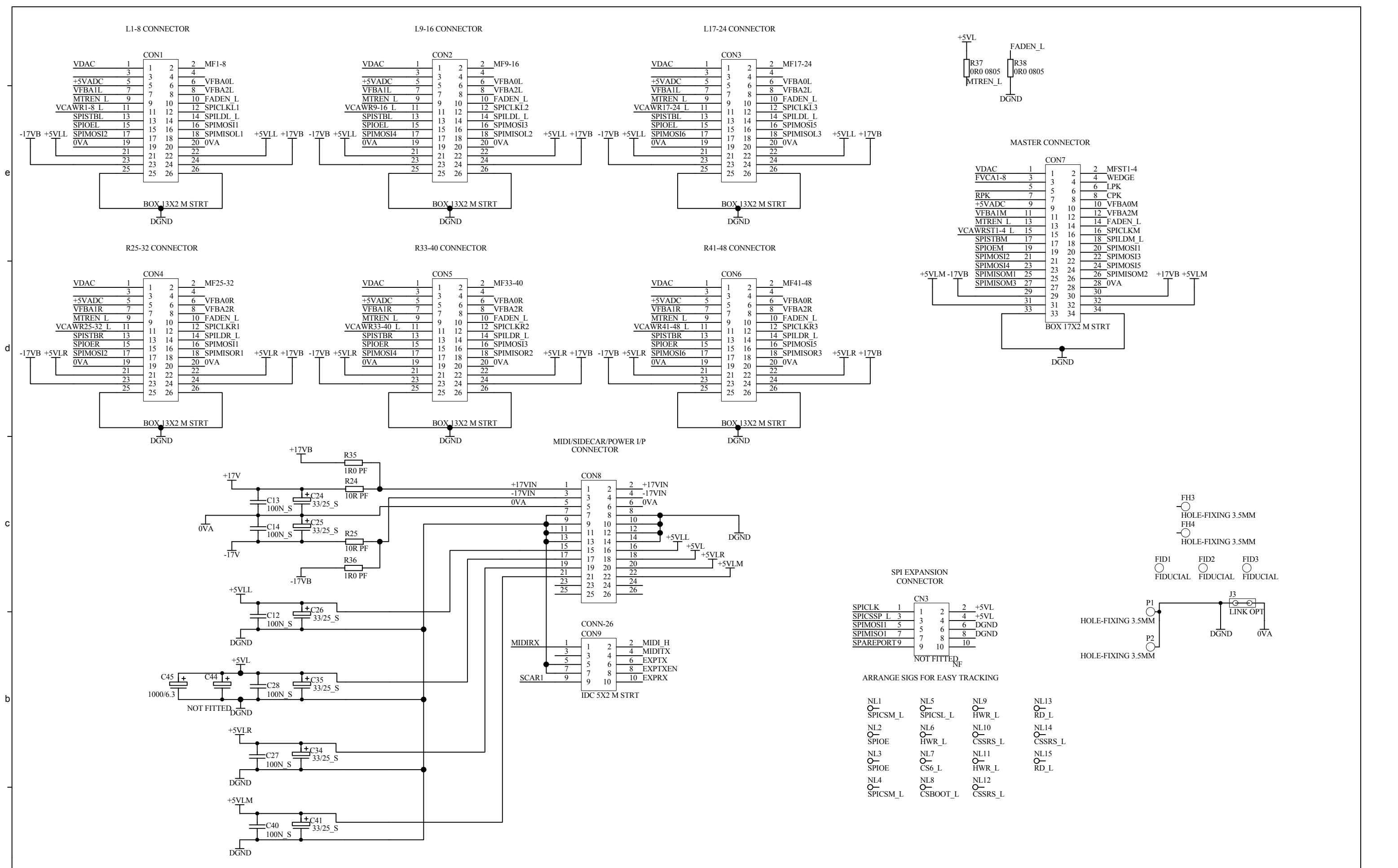

**ALLEN&HEATH**  
 Kernick Industrial Estate,  
 Penryn, Cornwall,  
 England. TR10 9LU  
 Tel: +44 (0)8707 556250  
 Fax: +44 (0)8707 556251

ISSUE	BY	DATE
ISS 3	AAT	07-12-00
ISS 3.1	AAT	26-01-01
ISS 3.2	AAT	26-10-01
ISS 4	AAT	20-11-01

FILE: AG3718\_4P4.SCH      PRINTED: 15:43:48 7-Jan-2002

TITLE: **ML3/4/5000 CPU PCB**  
 PAGE: CONNECTORS  
 DRG No: AG3718    ISSUE: 4    SHEET: 4 OF 4

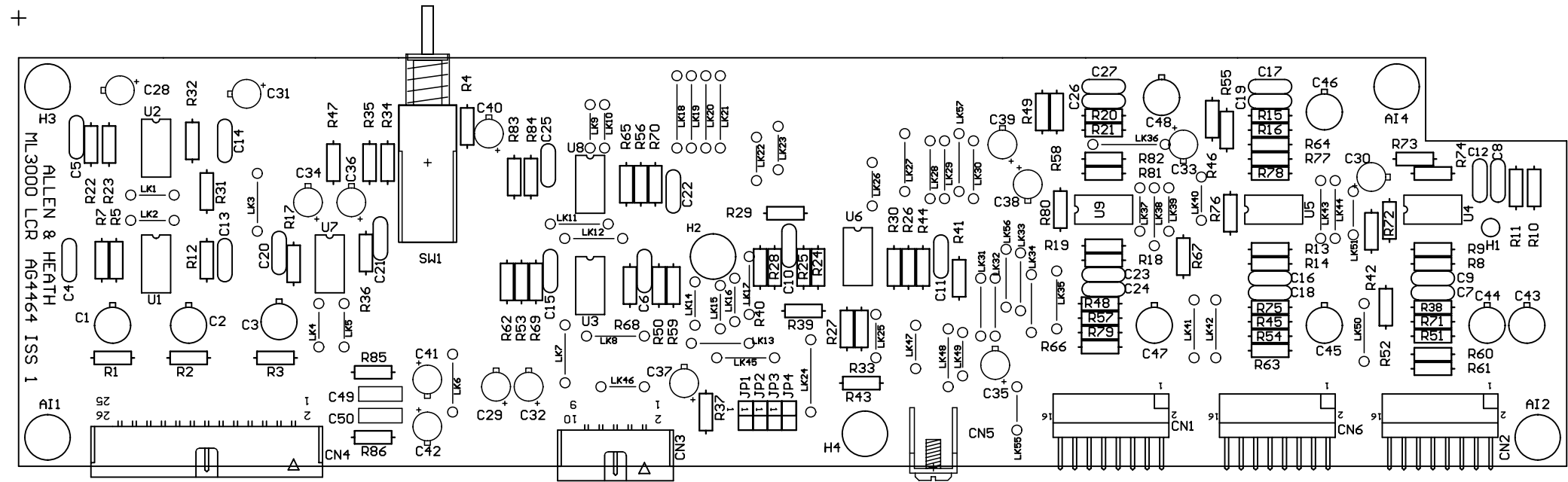

**ALLEN & HEATH**  
 Kernick Industrial Estate,  
 Penryn, Cornwall,  
 England. TR10 9LU  
 Tel: +44 (0)8707 556250  
 Fax: +44 (0)8707 556251

FILE: AG4464\_1.PCB

PRINTED: 16:32:00 7-Jan-2002

TITLE: ML3000 LCR PCB

DRG No: AG4464 ISSUE: 1

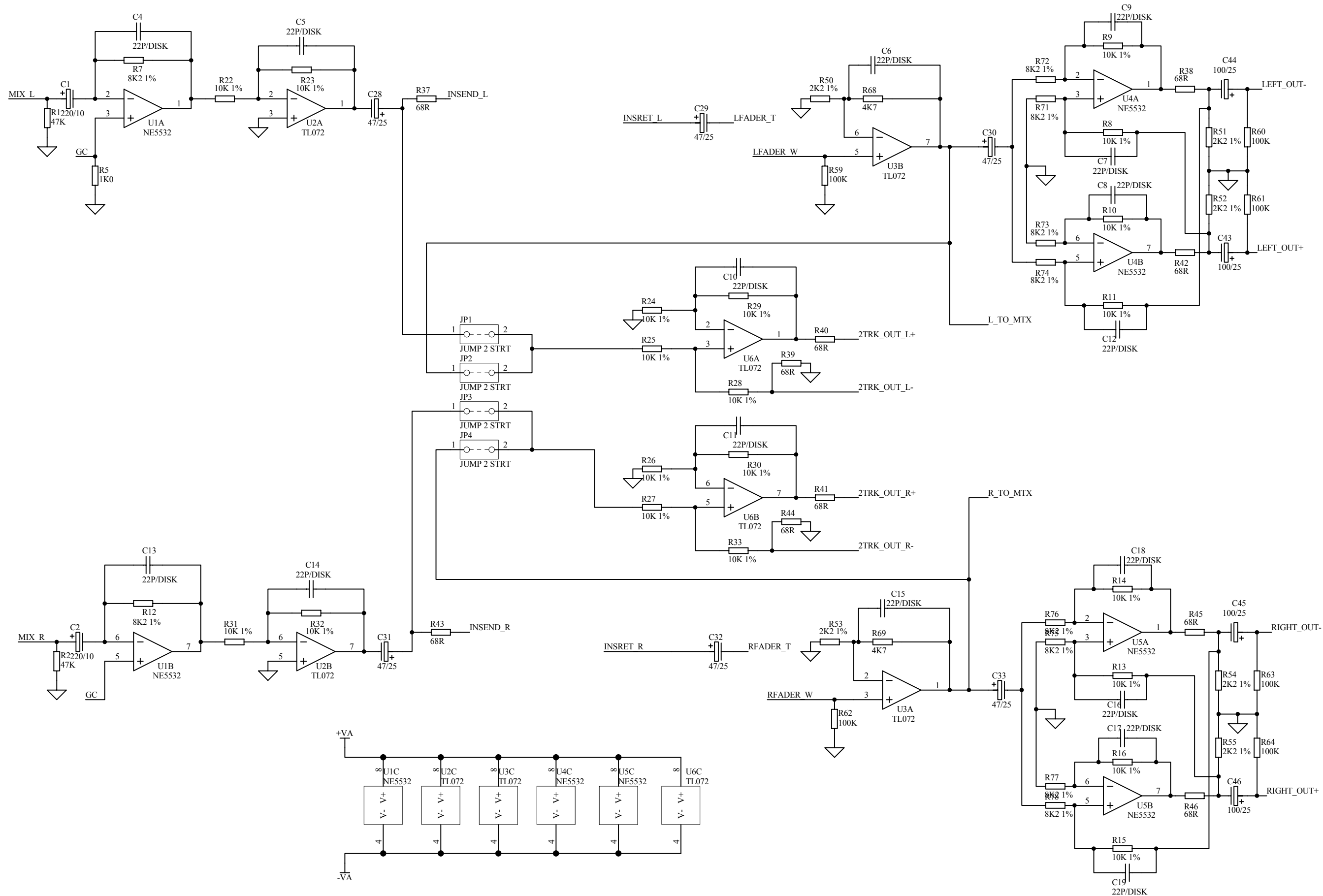

**ALLEN&HEATH**  
 Kernick Industrial Estate,  
 Penryn, Cornwall,  
 England. TR10 9LU  
 Tel: +44 (0)8707 556250  
 Fax: +44 (0)8707 556251

ISSUE	BY	DATE

FILE: C4464\_1P1.Sch    PRINTED: 13:55:41    17-Jan-2002

TITLE: ML3000 LCR PCB  
 PAGE:

DRG No: 4464    ISSUE: 1    SHEET: 1 OF 2

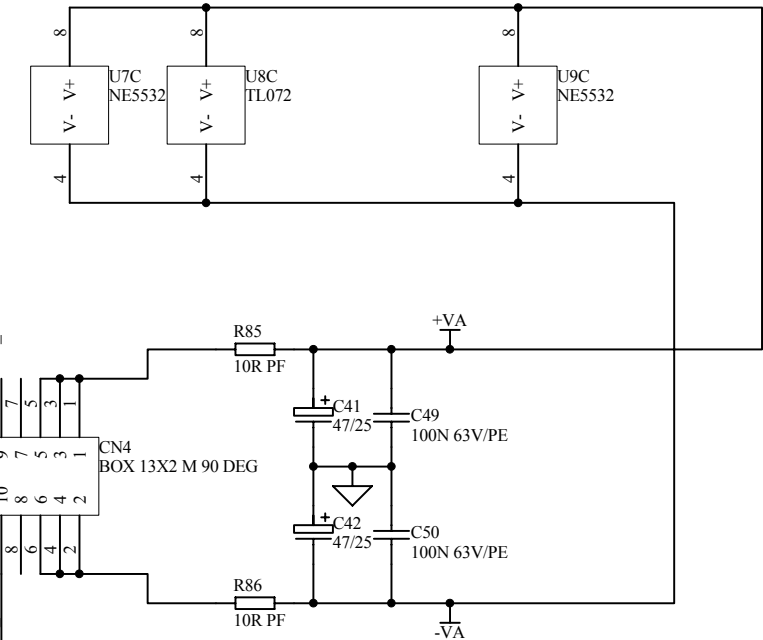
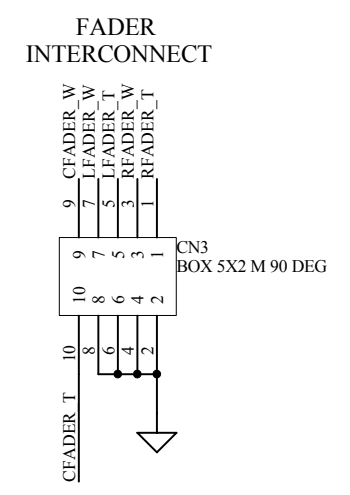
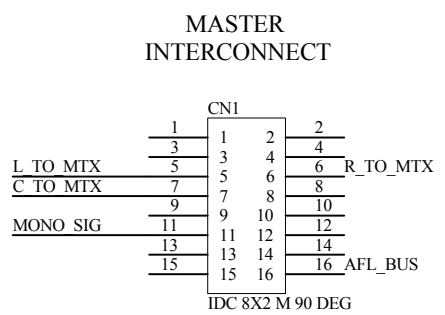
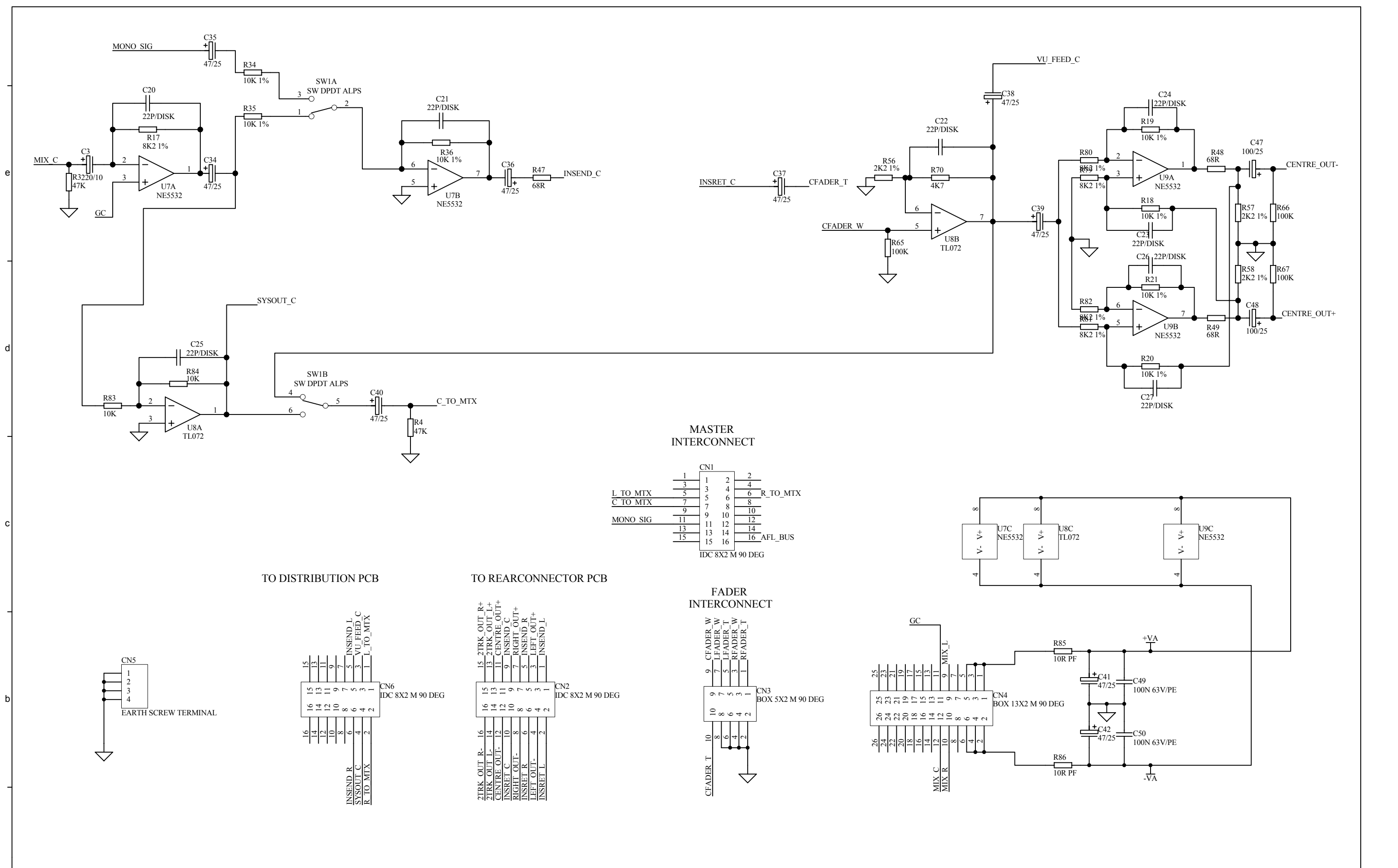

TO DISTRIBUTION PCB

TO REARCONNECTOR PCB

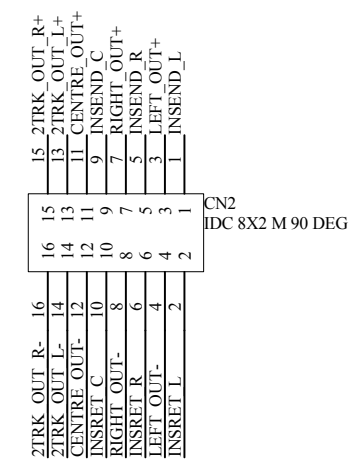
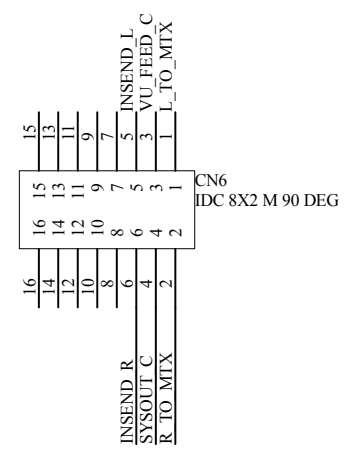
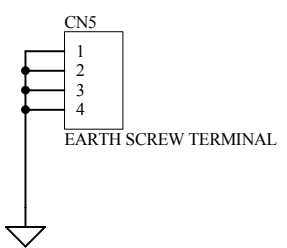

**ALLEN&HEATH**  
Kernick Industrial Estate,  
Penryn, Cornwall,  
England. TR10 9LU  
Tel: +44 (0)8707 556250  
Fax: +44 (0)8707 556251

ISSUE	BY	DATE

FILE: C4464\_1P2.Sch PRINTED: 16:37:16 7-Jan-2002

TITLE: ML3000 LCR PCB  
PAGE:    
DRG No: 4464 ISSUE: 1 SHEET: 2 OF 2

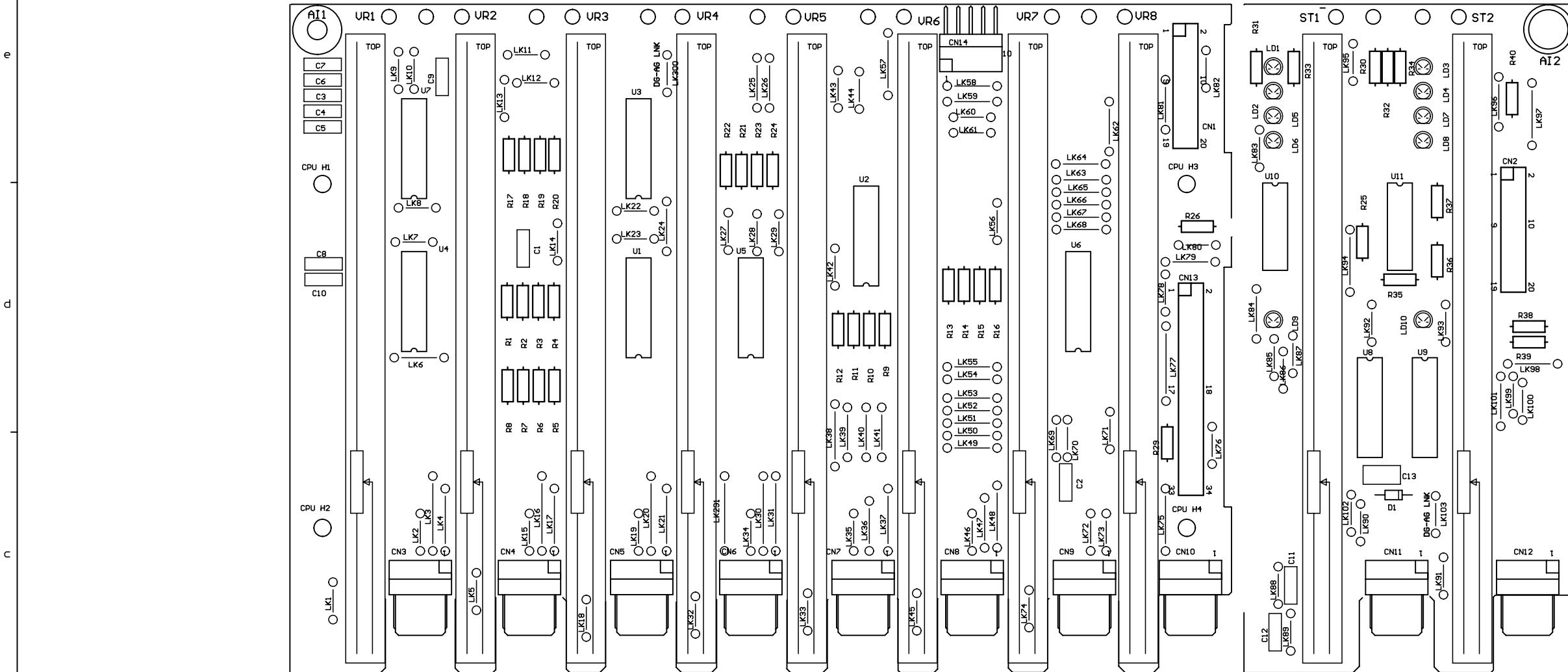

.GTO

**ALLEN & HEATH**  
 Kernick Industrial Estate,  
 Penryn, Cornwall,  
 England. TR10 9LU  
 Tel: +44 (0)8707 556250  
 Fax: +44 (0)8707 556251

FILE: AG4458\_1.PCB

PRINTED: 13:37:10 8-Jan-2002

TITLE:  
**ML3 MASTER FADER/STEREO FADER**  
 DRG No: AG4458 ISSUE: 1

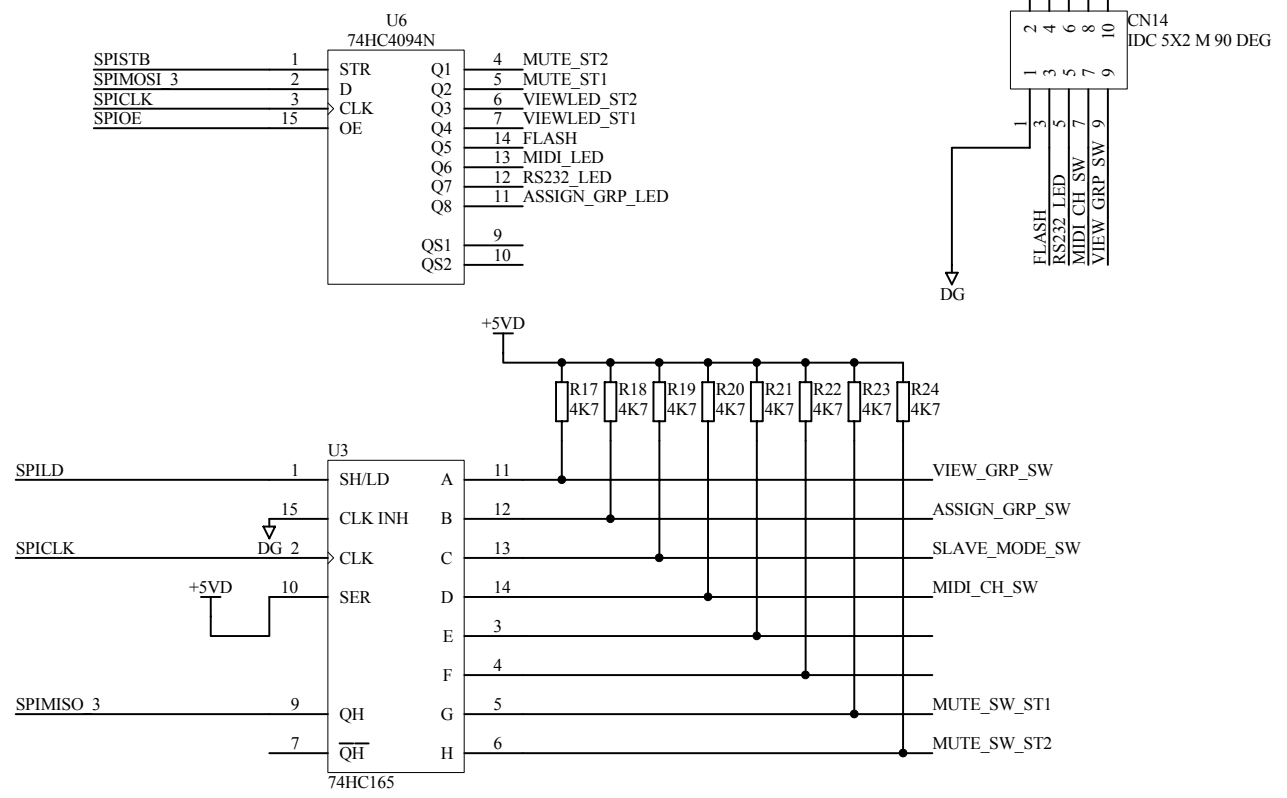
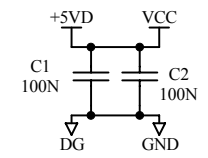
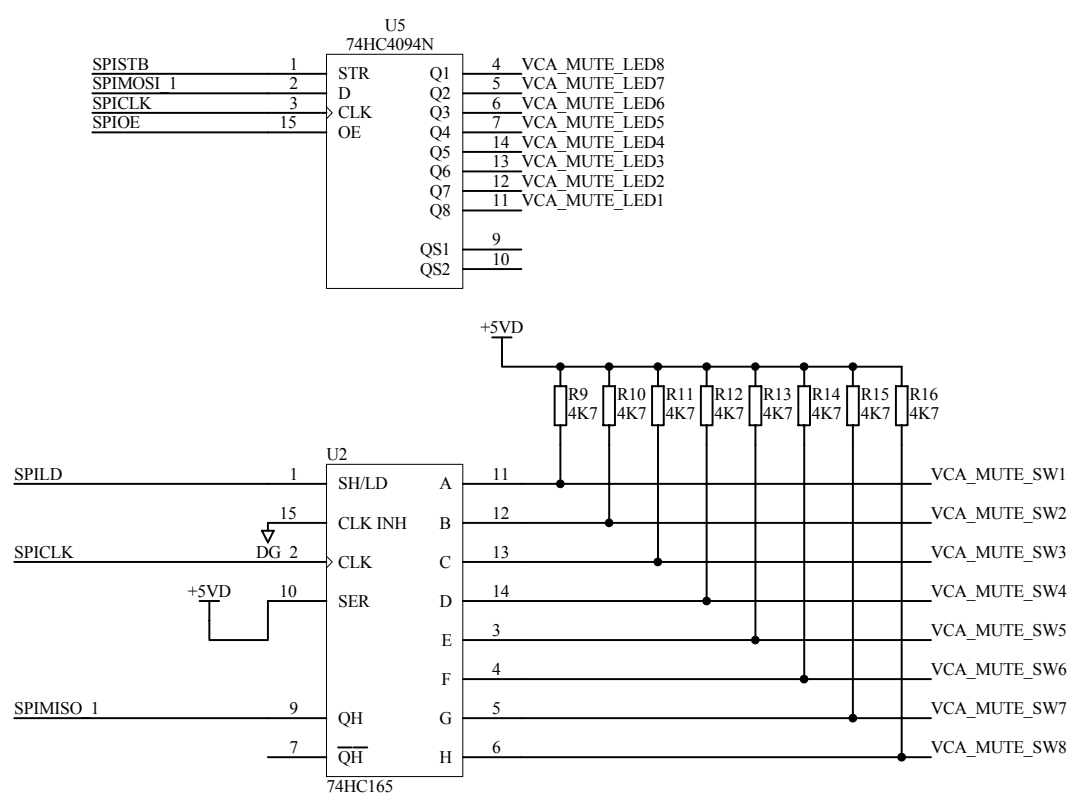
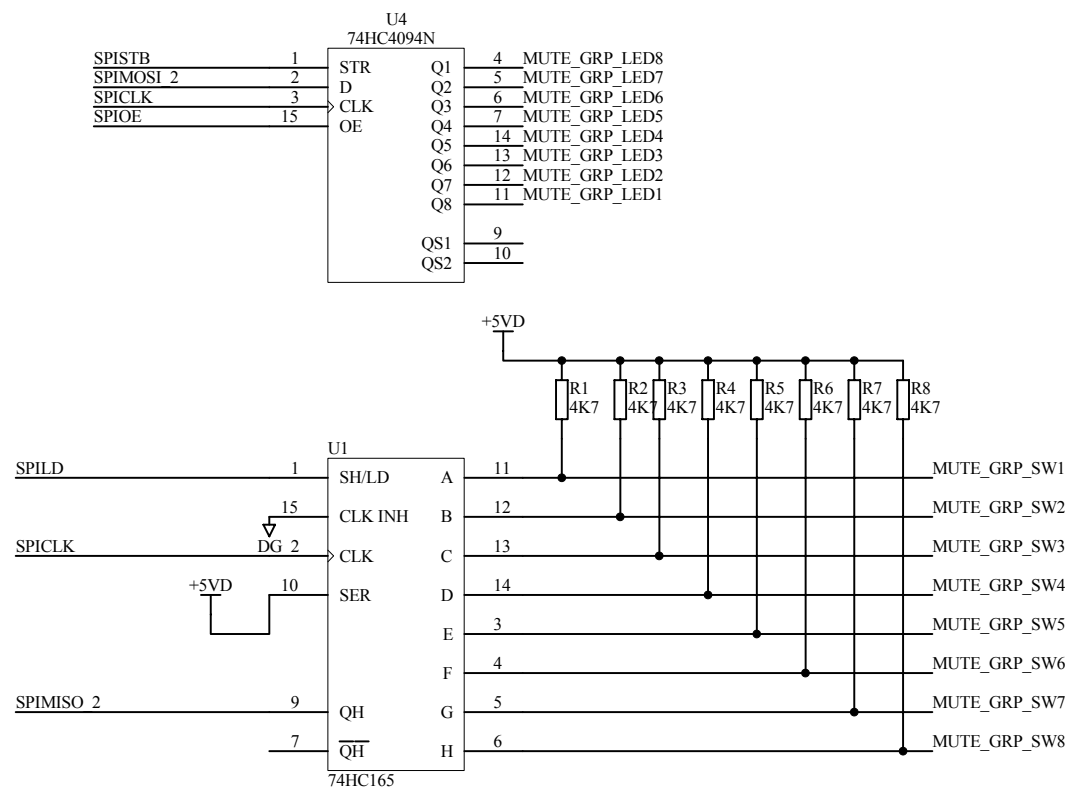

**ALLEN&HEATH**  
 Kernick Industrial Estate,  
 Penryn, Cornwall,  
 England. TR10 9LU  
 Tel: +44 (0)8707 556250  
 Fax: +44 (0)8707 556251

ISSUE	BY	DATE

FILE: C4458\_AP1.Sch      PRINTED: 13:51:51 8-Jan-2002

TITLE: **ML3000 MASTERFADER**  
 PAGE: 1  
 DRG No: **C4458**    ISSUE: 1    SHEET: 1 OF 3



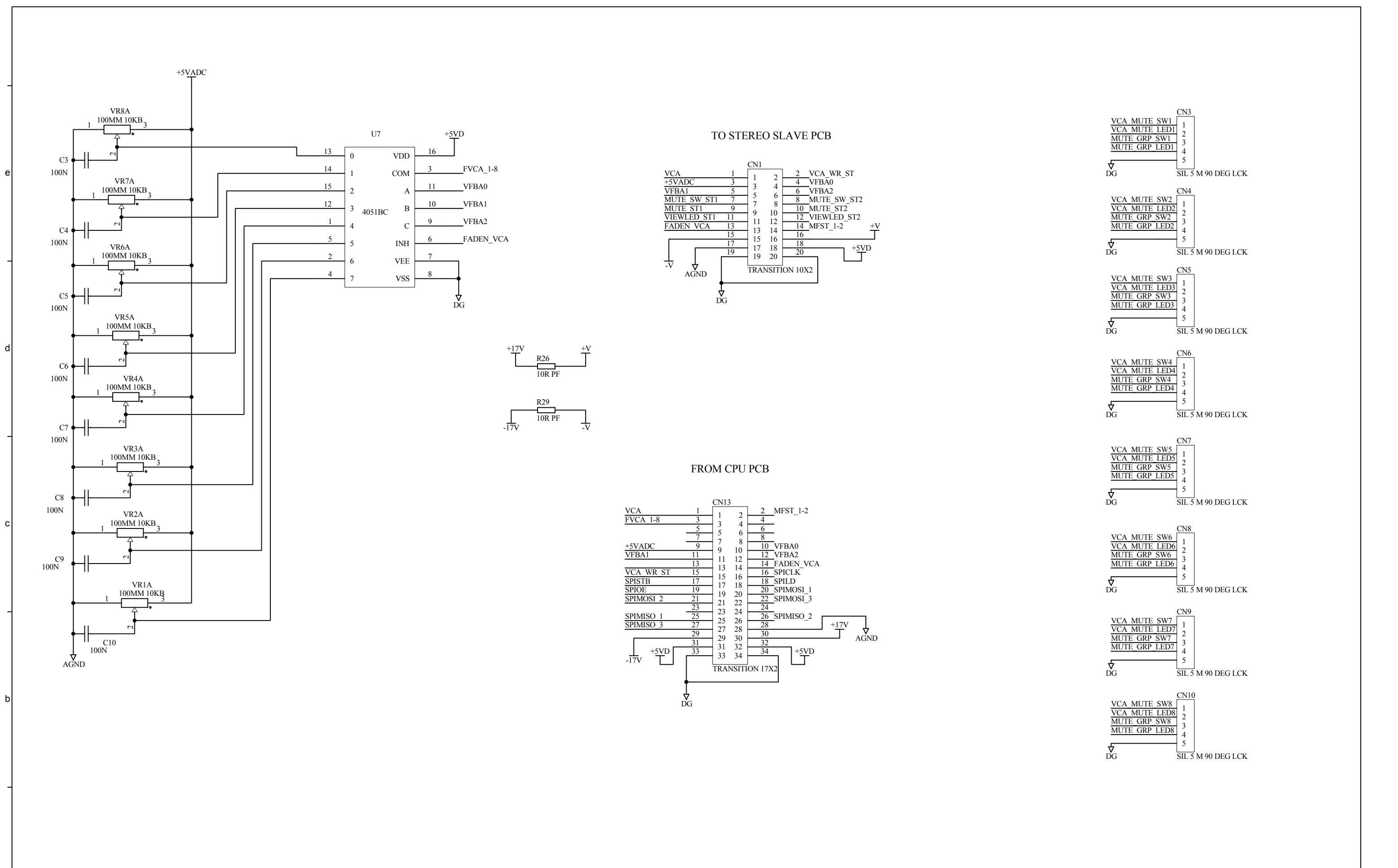

**ALLEN&HEATH**  
 Kernick Industrial Estate,  
 Penryn, Cornwall,  
 England. TR10 9LU  
 Tel: +44 (0)8707 556250  
 Fax: +44 (0)8707 556251

ISSUE	BY	DATE

100MM 10KB	100MM 10KB	100MM 10KB	100MM 10KB	100MM 10KB	100MM 10KB	100MM 10KB	100MM 10KB
FILE: C4458_AP2.Sch	PRINTED: 13:53:59 8-Jan-2002						

TITLE: **ML3000 MASTERFADER**  
 PAGE:    
 DRG No: **C4458** ISSUE: 1 SHEET: 2 OF 3

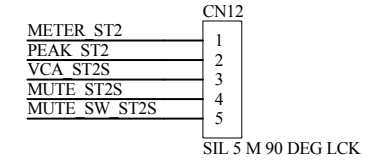
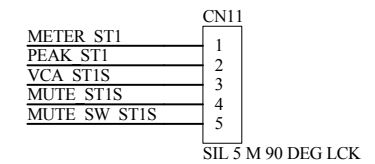
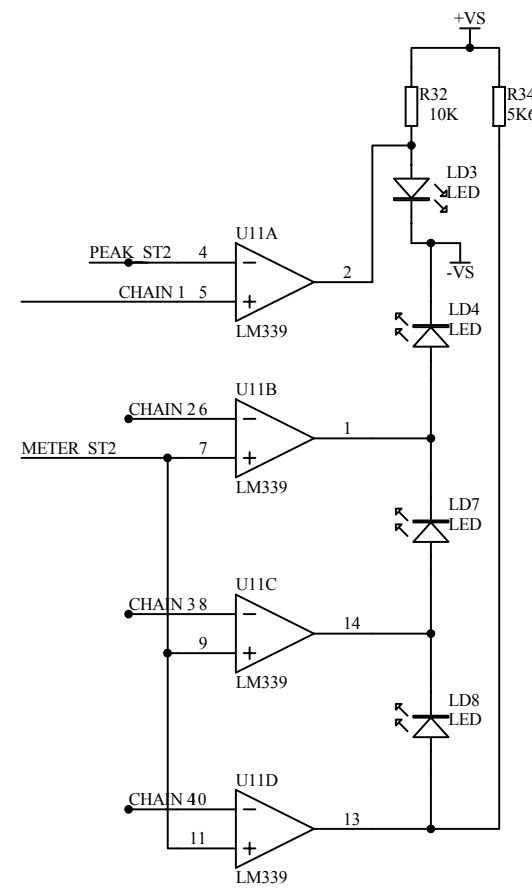
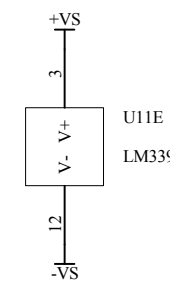
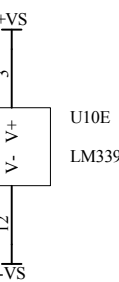
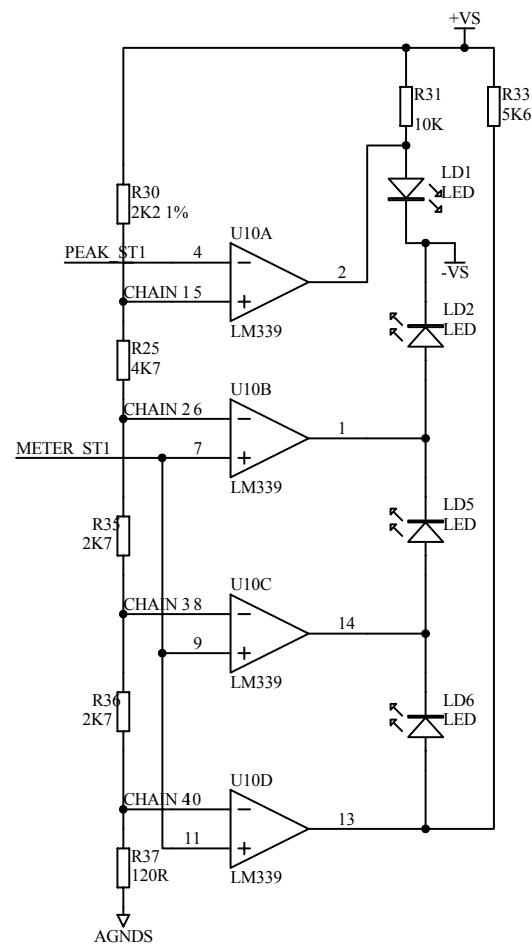
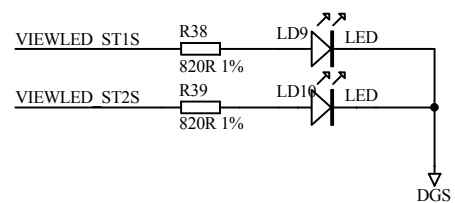
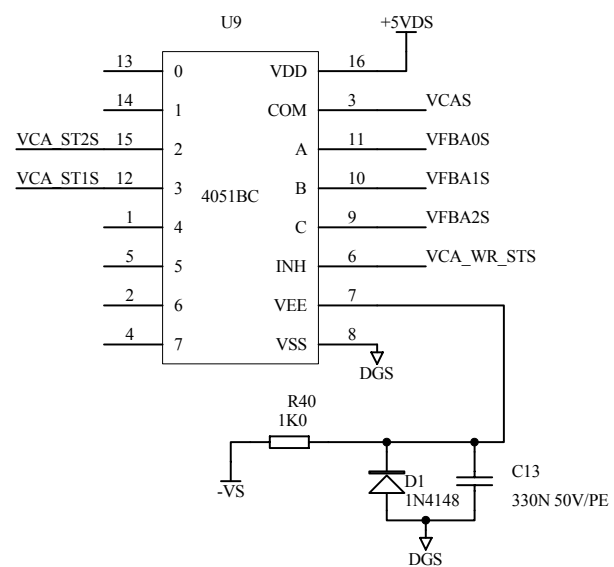
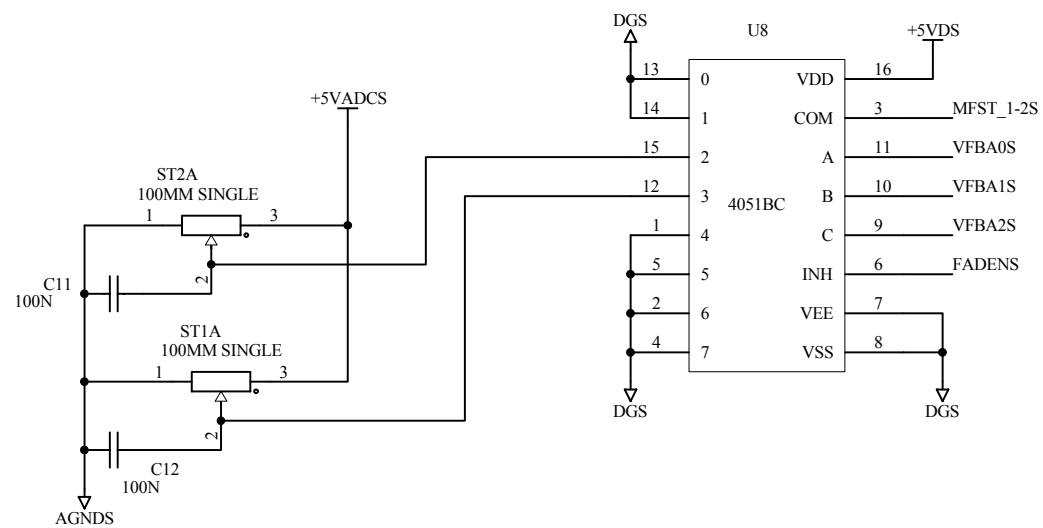

FROM MASTER SLAVE PCB

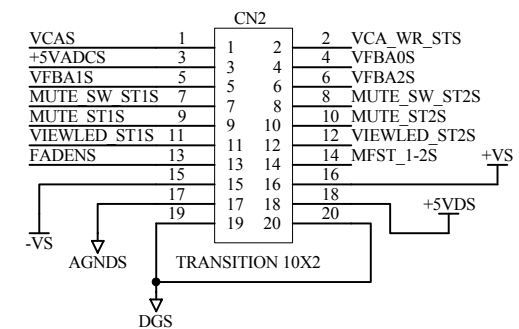

**ALLEN&HEATH**

Kernick Industrial Estate,  
Penryn, Cornwall,  
England. TR10 9LU  
Tel: +44 (0)8707 556250  
Fax: +44 (0)8707 556251

ISSUE	BY	DATE



ST1B  
FADER ALPS 100MM SINGLE PCB



ST2B  
FADER ALPS 100MM SINGLE PCB

FILE: C4458\_AP3.Sch

PRINTED: 14:10:34 8-Jan-2002

TITLE: ML3000 MASTERFADER

PAGE:

DRG No: C4458 ISSUE: 1 SHEET: 3 OF 3

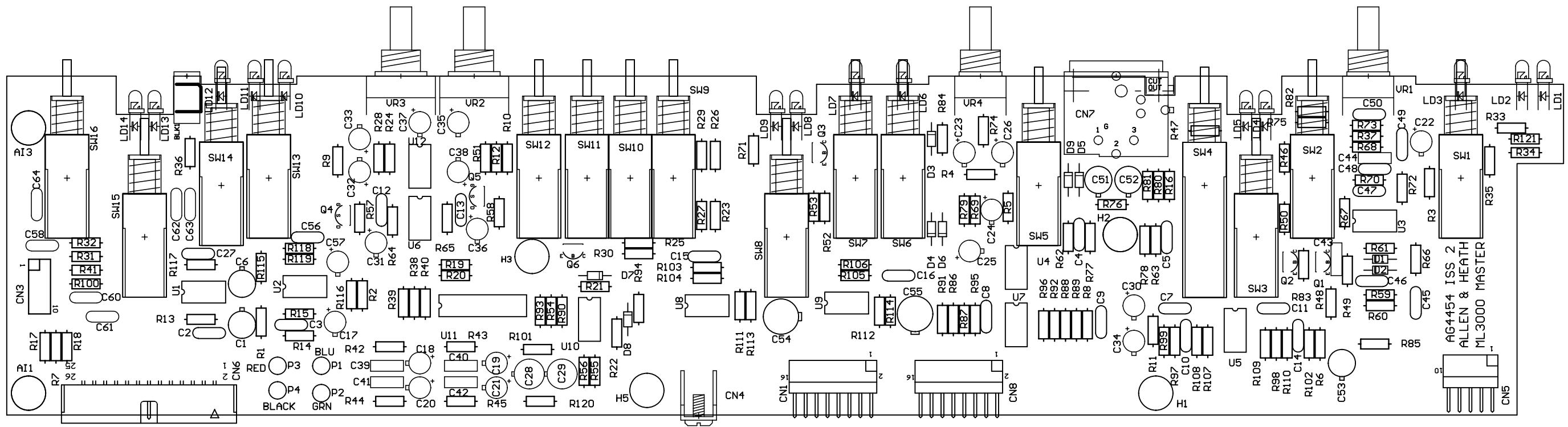

**ALLEN & HEATH**

Kernick Industrial Estate,  
Penryn, Cornwall,  
England, TR10 9LU

Tel: +44 (0)8707 556250  
Fax: +44 (0)8707 556251

FILE: AG4454\_2.PCB

CTO  
PRINTED: 14:45:02 8-Jan-2002

TITLE: ML3000 MASTER PCB

DRG No: AG4454 ISSUE: 2

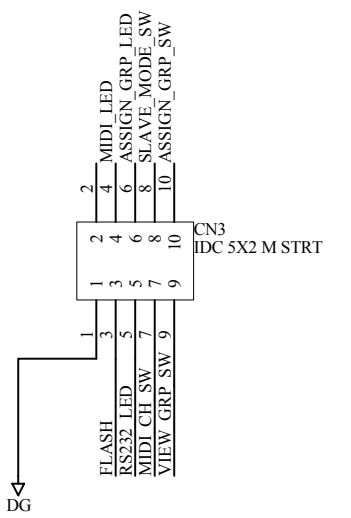
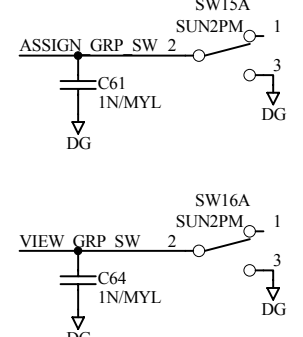
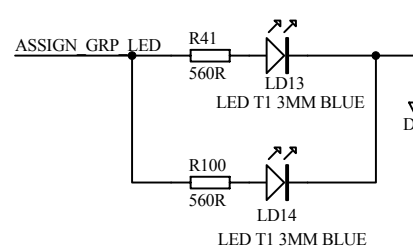
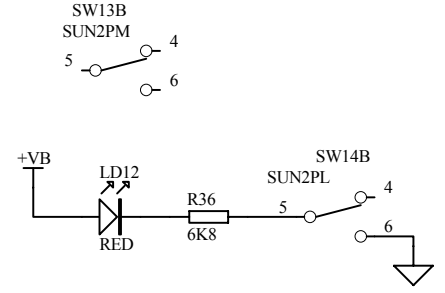
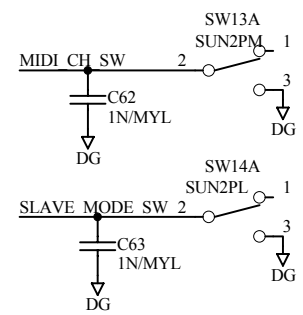
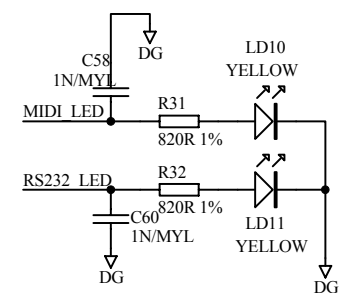
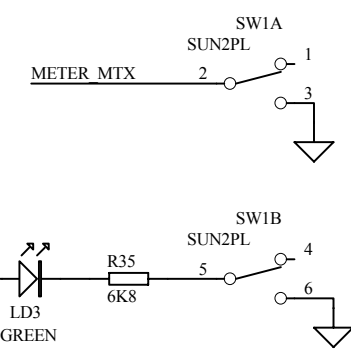
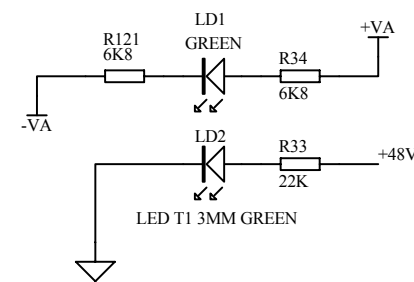
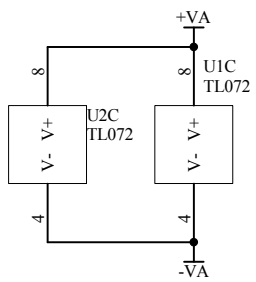
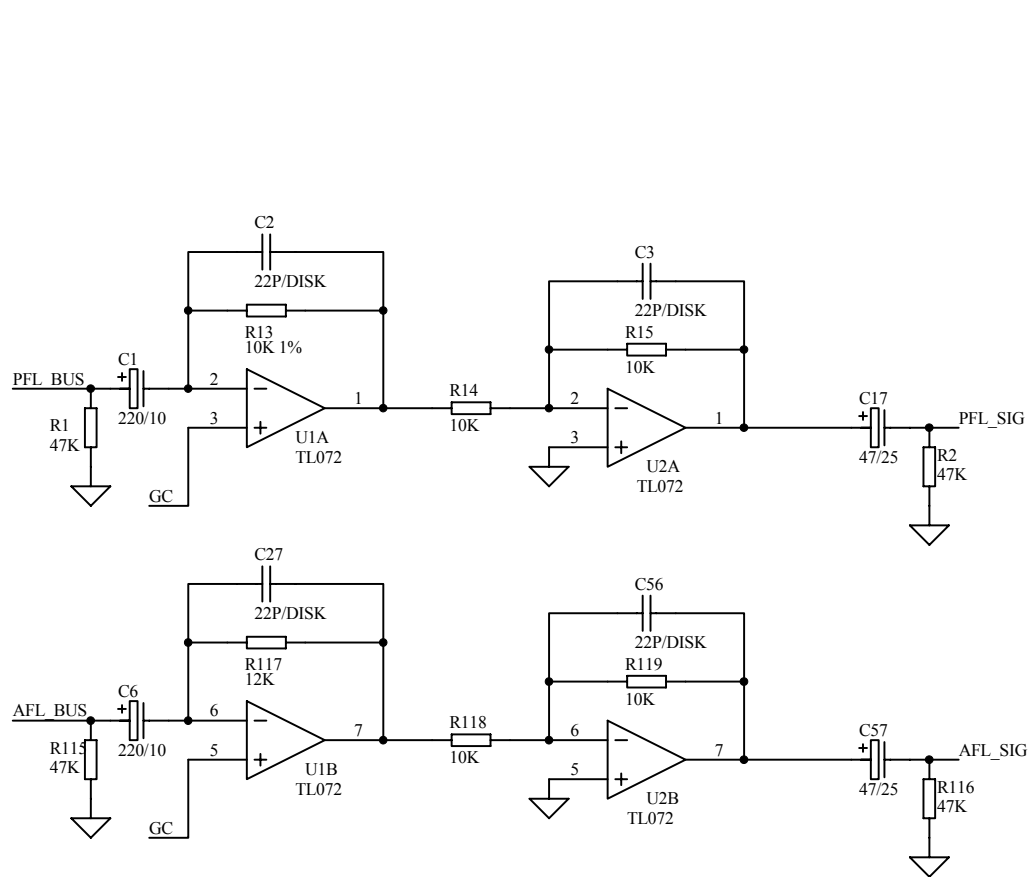

**TO DISTRIBUTION PCB**

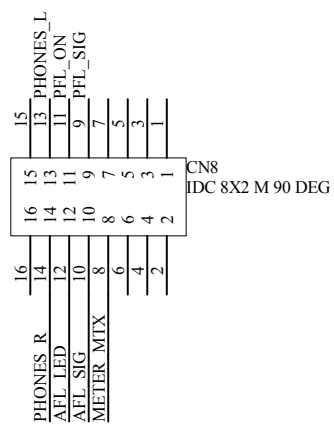

**MASTER INTERCONNECT**

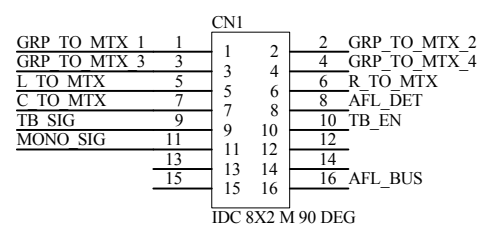

**TO REARCONNECTOR PCB**

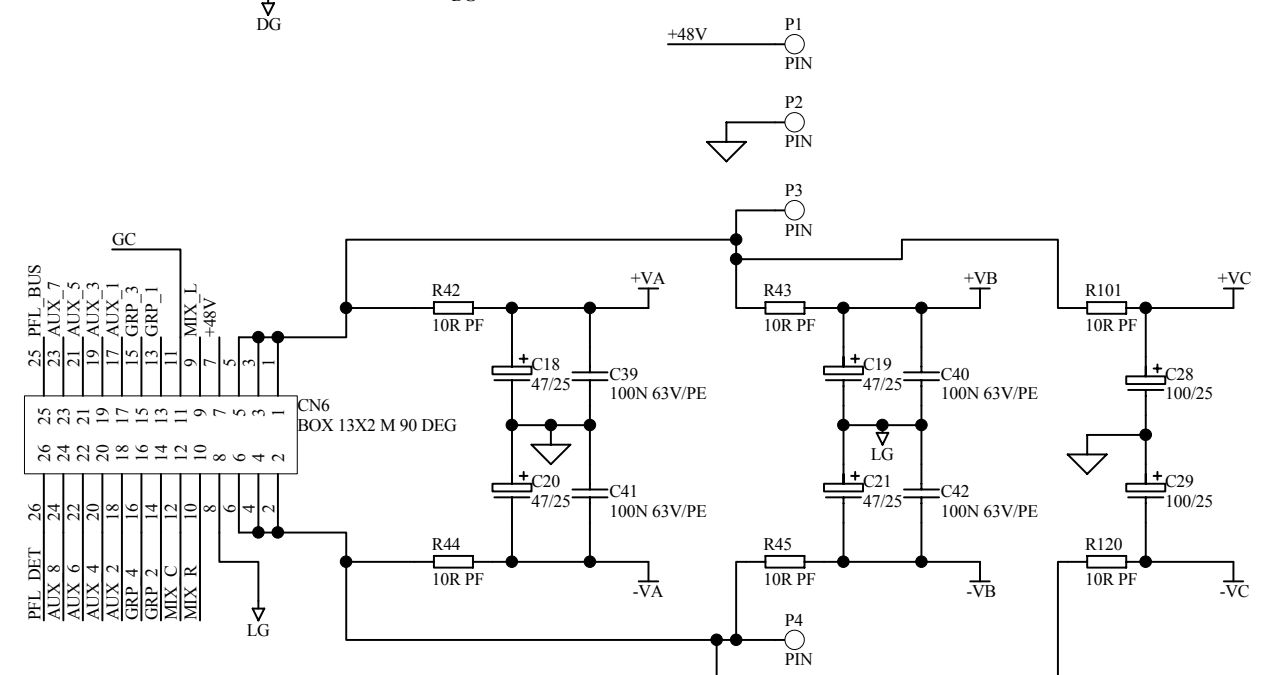
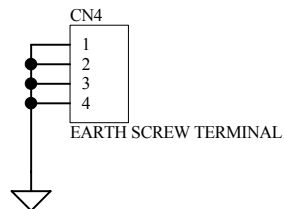
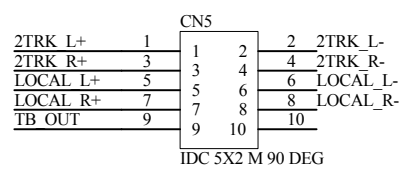

**ALLEN&HEATH**

Kernick Industrial Estate,  
Penryn, Cornwall,  
England. TR10 9LU  
Tel: +44 (0)8707 556250  
Fax: +44 (0)8707 556251

ISSUE	BY	DATE
2.1	DWD	14-01-02

FILE: C4454\_2P1.Sch PRINTED: 10:12:28 14-Jan-2002

TITLE: **ML3000 MASTER**

PAGE:

DRG No: 4454 ISSUE: 2.1 SHEET: 1 OF 3

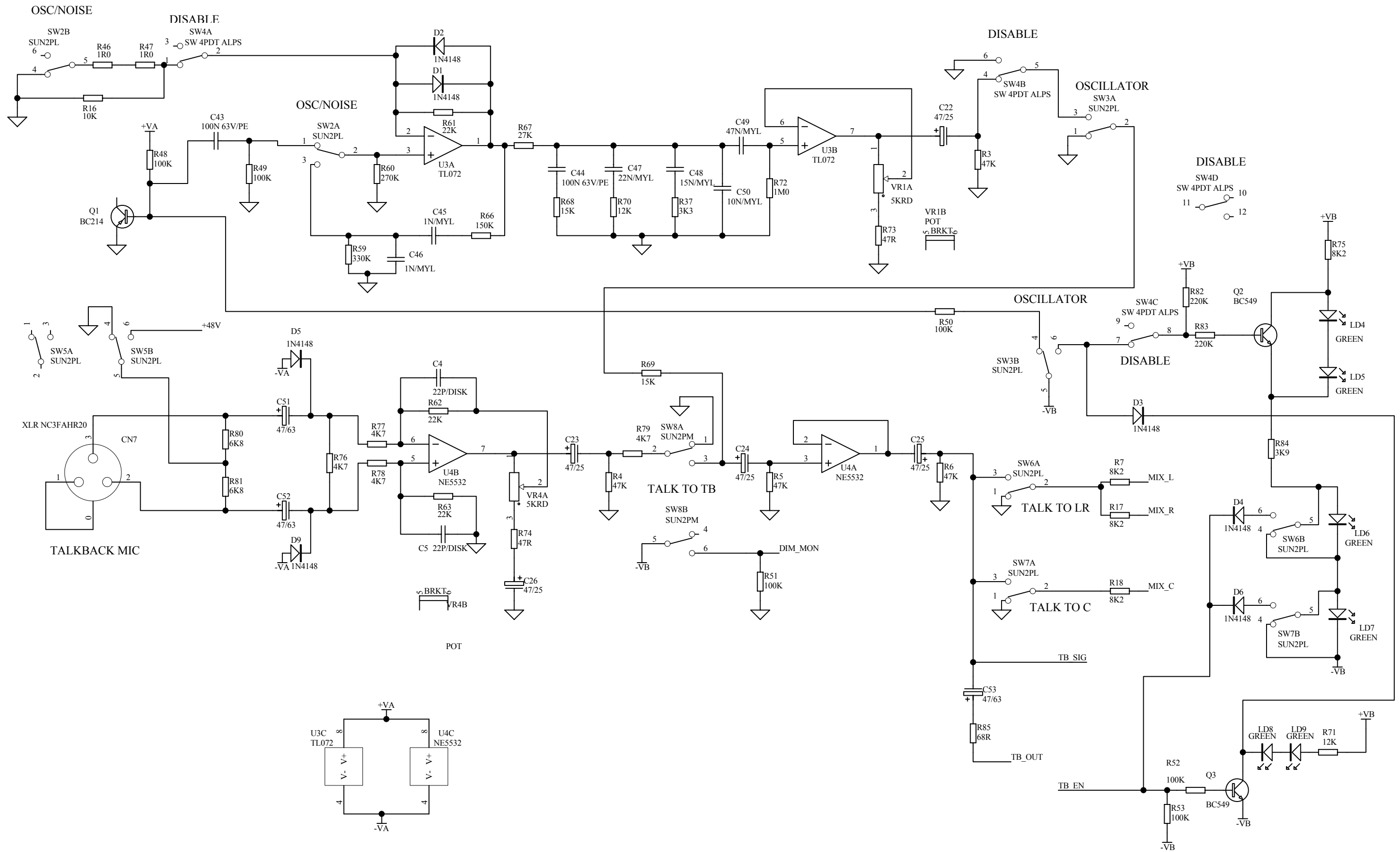

**ALLEN&HEATH**

Kernick Industrial Estate,  
Penryn, Cornwall,  
England. TR10 9LU  
Tel: +44 (0)8707 556250  
Fax: +44 (0)8707 556251

ISSUE	BY	DATE
2.1	DWD	14-01-02

FILE: C4454\_2P2.Sch

PRINTED: 10:13:30 14-Jan-2002

TITLE: ML3000 MASTER

PAGE:

DRG No: 4454

ISSUE: 2.1 SHEET: 2 OF 3

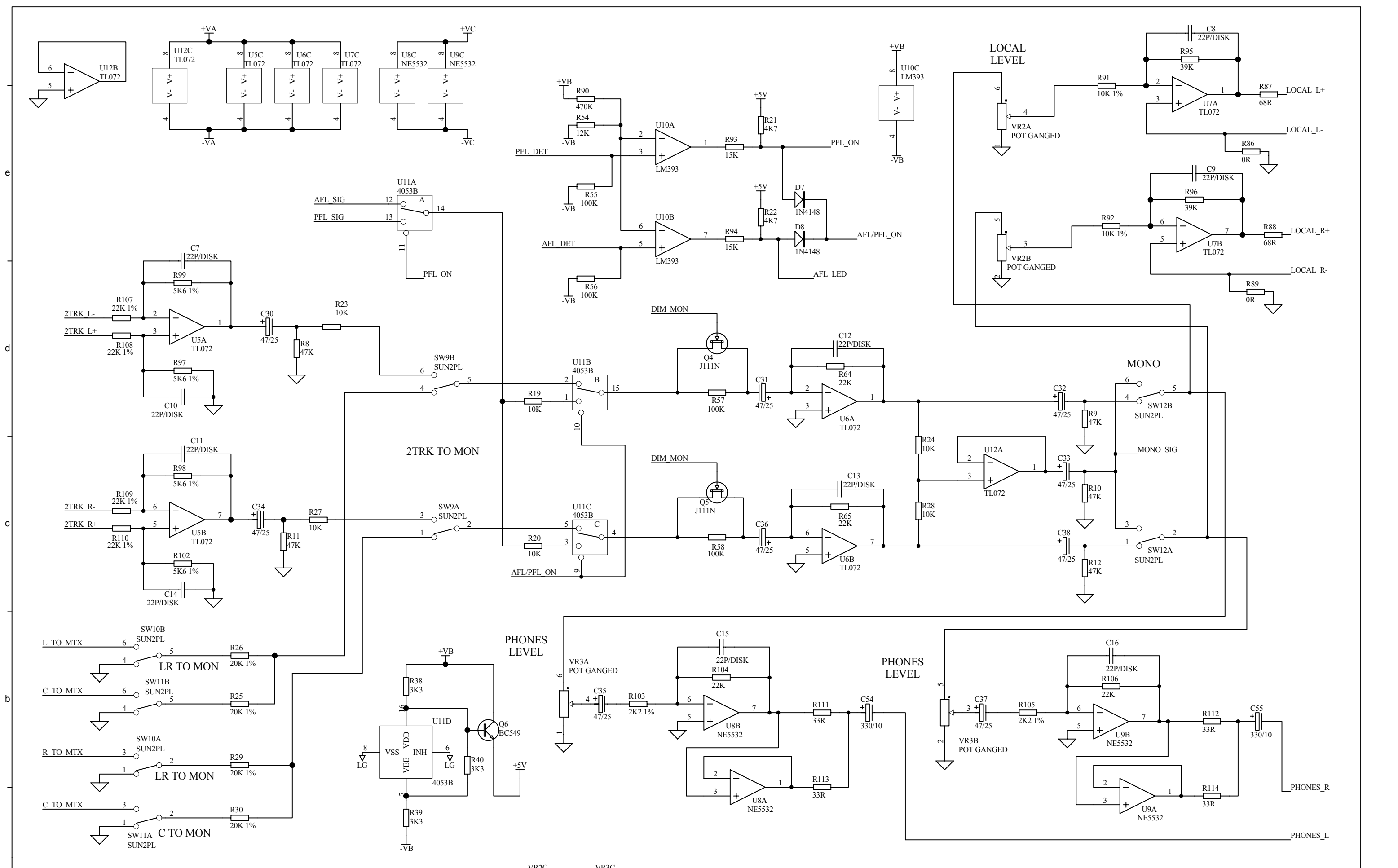

<b>ALLEN&amp;HEATH</b> Kernick Industrial Estate, Penryn, Cornwall, England. TR10 9LU Tel: +44 (0)8707 556250 Fax: +44 (0)8707 556251	ISSUE	BY	DATE	FILE: C4454_2P3.Sch PRINTED: 10:14:18 14-Jan-2002	TITLE: <b>ML3000 MASTER</b> PAGE:
	2.1	DWD	14-01-02		

a b c d e

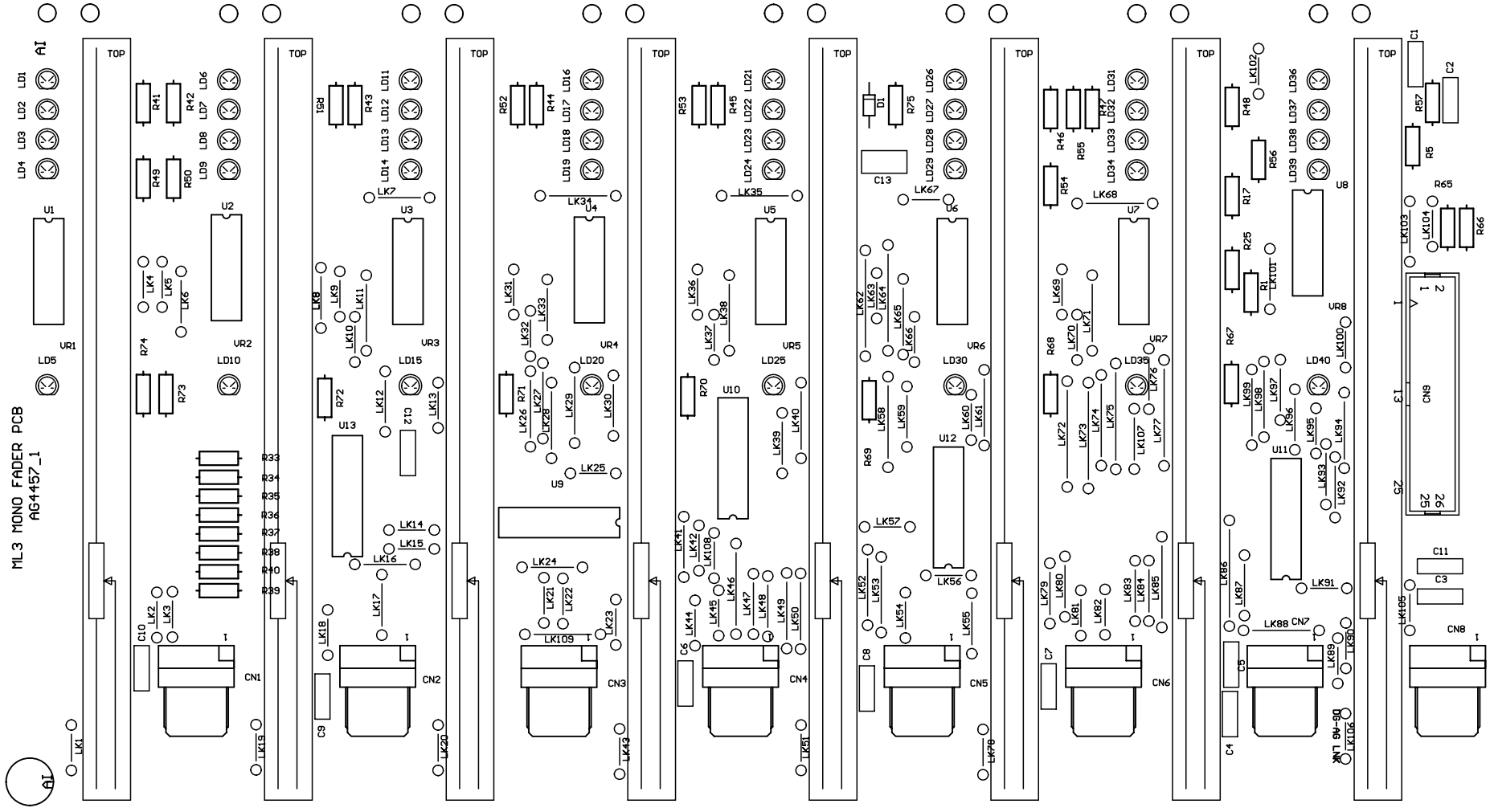

**ALLEN & HEATH**  
 Kernick Industrial Estate,  
 Penryn, Cornwall,  
 England, TR10 9LU  
 Tel: +44 (0)8707 556250  
 Fax: +44 (0)8707 556251

FILE: AG4457\_1.PCB  
 PRINTED: 13:36:44 17-Jan-2002

TITLE: ML3 MONO FADER PCB  
 DRG No: AG4457 ISSUE: 1

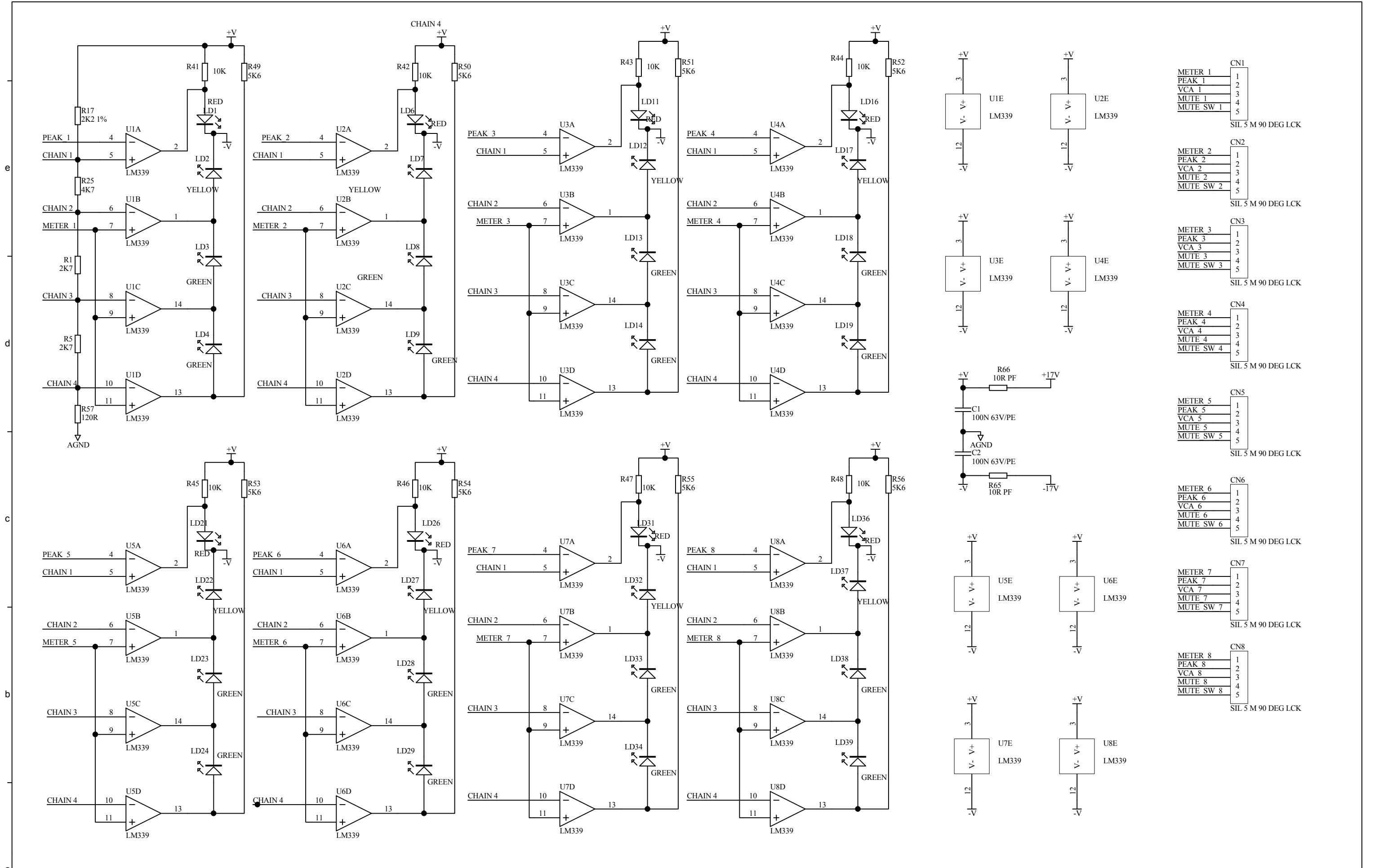

- CN1  
METER 1  
PEAK 1  
VCA 1  
MUTE 1  
MUTE SW 1  
SIL 5 M 90 DEG LCK
- CN2  
METER 2  
PEAK 2  
VCA 2  
MUTE 2  
MUTE SW 2  
SIL 5 M 90 DEG LCK
- CN3  
METER 3  
PEAK 3  
VCA 3  
MUTE 3  
MUTE SW 3  
SIL 5 M 90 DEG LCK
- CN4  
METER 4  
PEAK 4  
VCA 4  
MUTE 4  
MUTE SW 4  
SIL 5 M 90 DEG LCK
- CN5  
METER 5  
PEAK 5  
VCA 5  
MUTE 5  
MUTE SW 5  
SIL 5 M 90 DEG LCK
- CN6  
METER 6  
PEAK 6  
VCA 6  
MUTE 6  
MUTE SW 6  
SIL 5 M 90 DEG LCK
- CN7  
METER 7  
PEAK 7  
VCA 7  
MUTE 7  
MUTE SW 7  
SIL 5 M 90 DEG LCK
- CN8  
METER 8  
PEAK 8  
VCA 8  
MUTE 8  
MUTE SW 8  
SIL 5 M 90 DEG LCK

**ALLEN&HEATH**  
 Kernick Industrial Estate,  
 Penryn, Cornwall,  
 England. TR10 9LU  
 Tel: +44 (0)8707 556250  
 Fax: +44 (0)8707 556251

ISSUE	BY	DATE

FILE: C4457\_1P1.Sch    PRINTED: 14:05:07 17-Jan-2002

TITLE: **ML3000 MONO FADER PCB**  
 PAGE:  
 DRG No: **C4457**    ISSUE: 1    SHEET: 1 OF 2



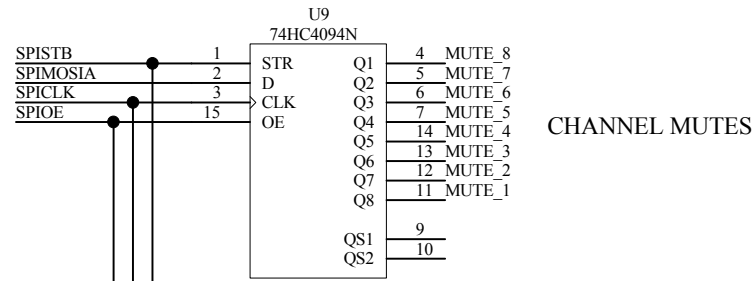

CHANNEL MUTES

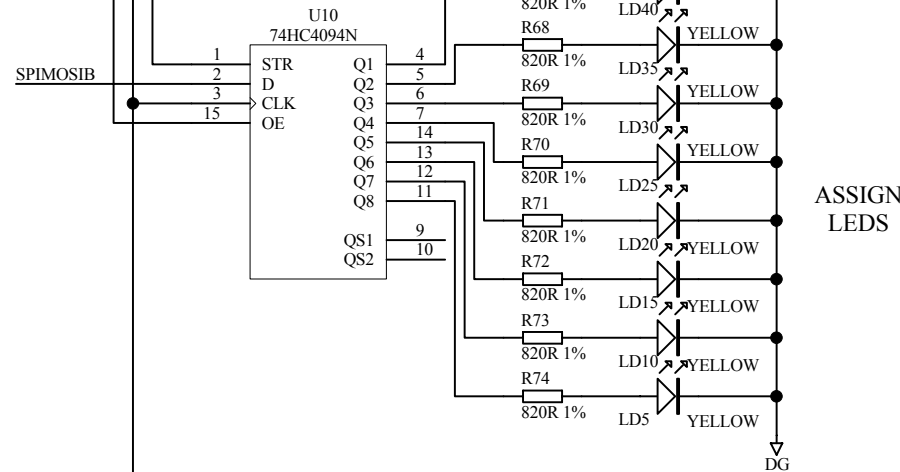

ASSIGN LEDES

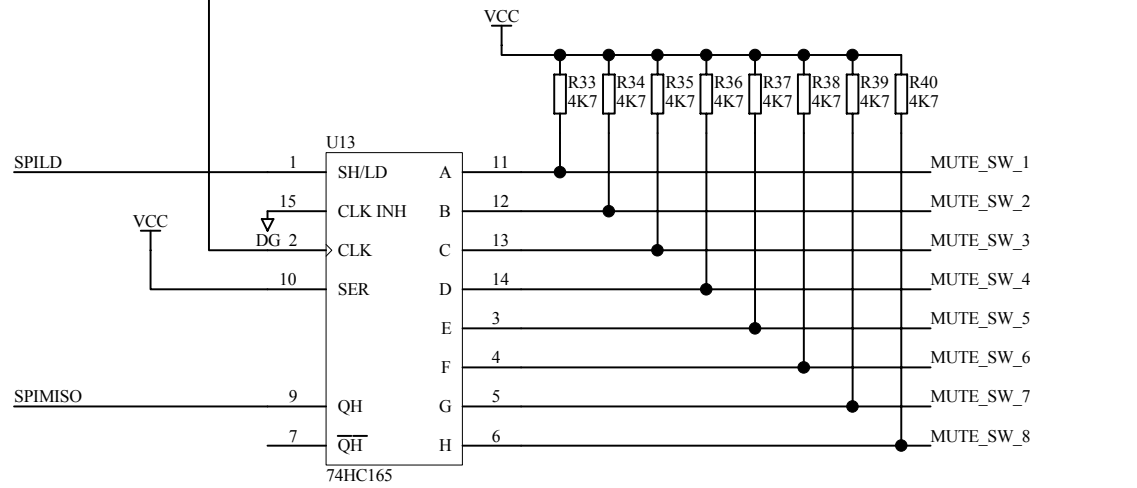

FROM CHANNEL MUTE SWITCHES

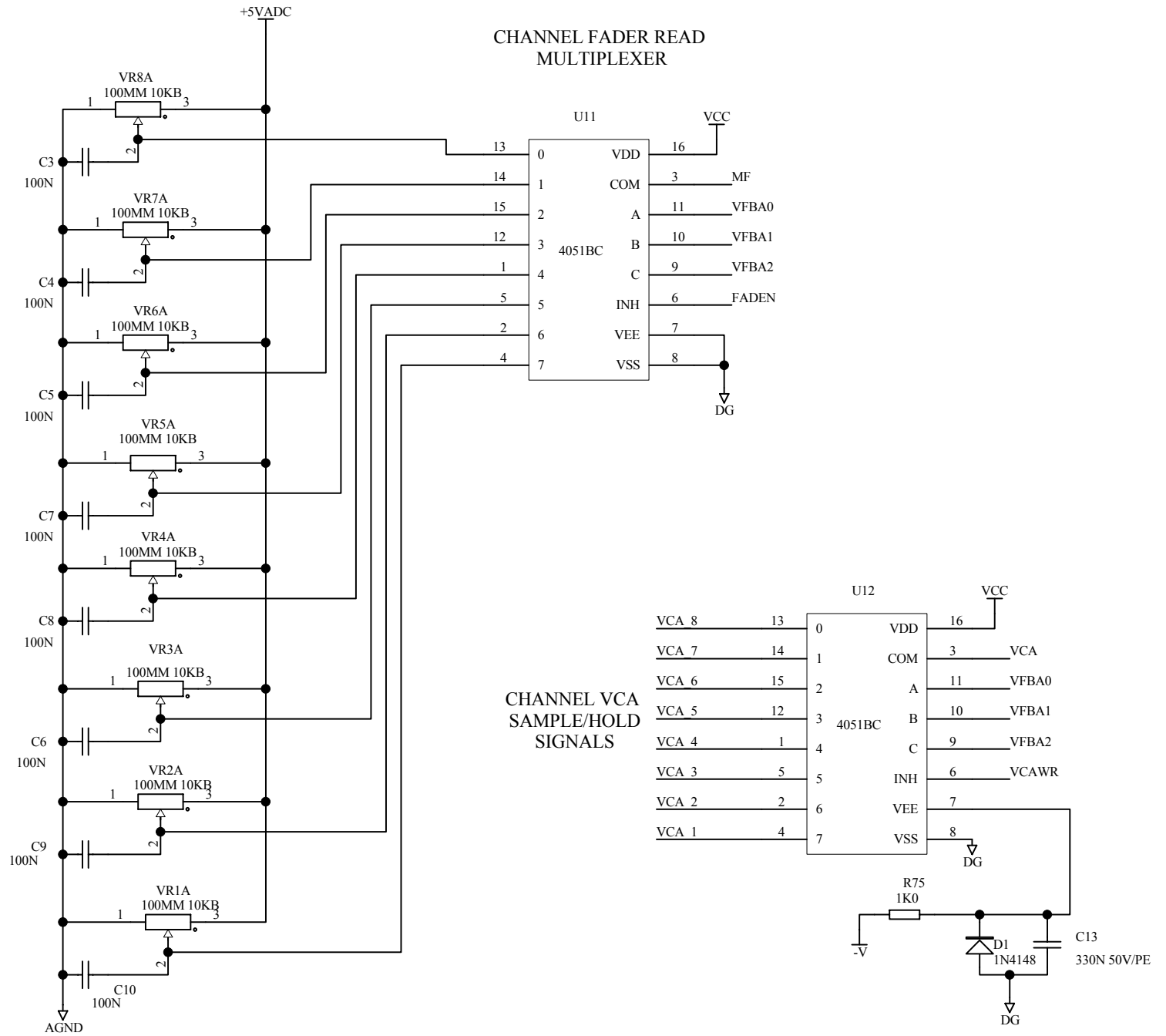
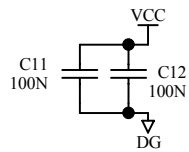

CHANNEL VCA SAMPLE/HOLD SIGNALS

FROM CPU PCB

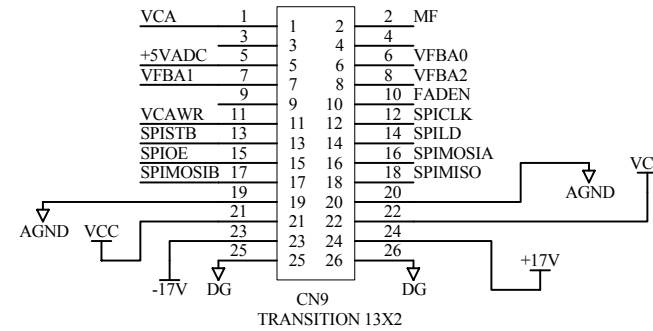

**ALLEN&HEATH**

Kernick Industrial Estate,  
Penryn, Cornwall,  
England. TR10 9LU  
Tel: +44 (0)8707 556250  
Fax: +44 (0)8707 556251

ISSUE	BY	DATE



FILE: C4457\_1P2.Sch PRINTED: 14:08:03 17-Jan-2002

TITLE: **ML3000 MONO FADER**

PAGE:

DRG No: **C4457** ISSUE: 1 SHEET: 2 OF 2

e  
d  
c  
b  
a

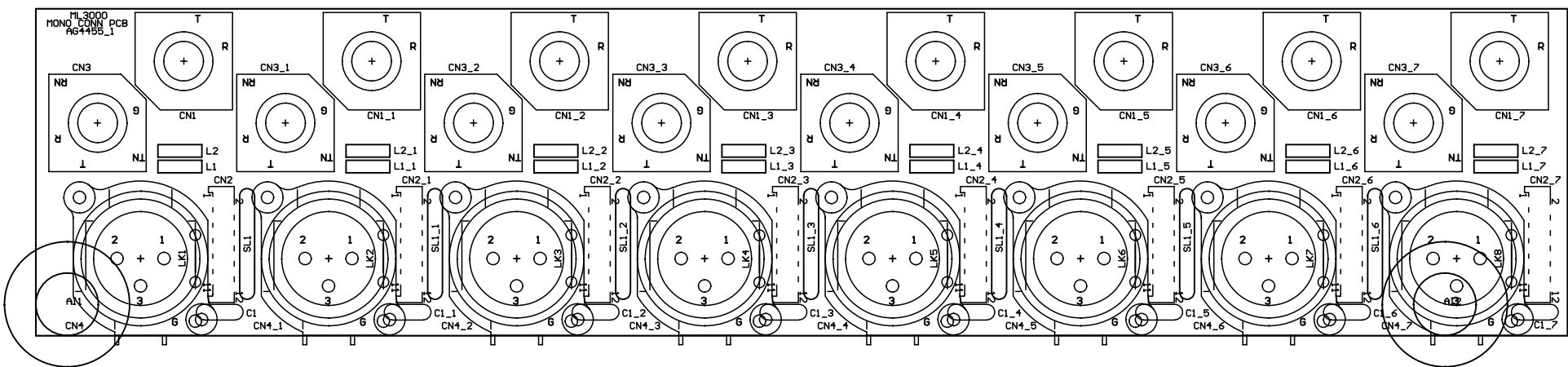

**ALLEN&HEATH**  
Kernick Industrial Estate,  
Penryn, Cornwall,  
England,TR10 9LU  
Tel: +44 (0)8707 556250  
Fax: +44 (0)8707 556251

TOP OVERLAY .GTO

FILE: AG4455\_1.PCB

PRINTED: 13:09:30 9-Jan-2002

TITLE: ML3000 MONO CONN PCB

DRG No: AG4455 ISSUE: 1

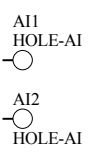
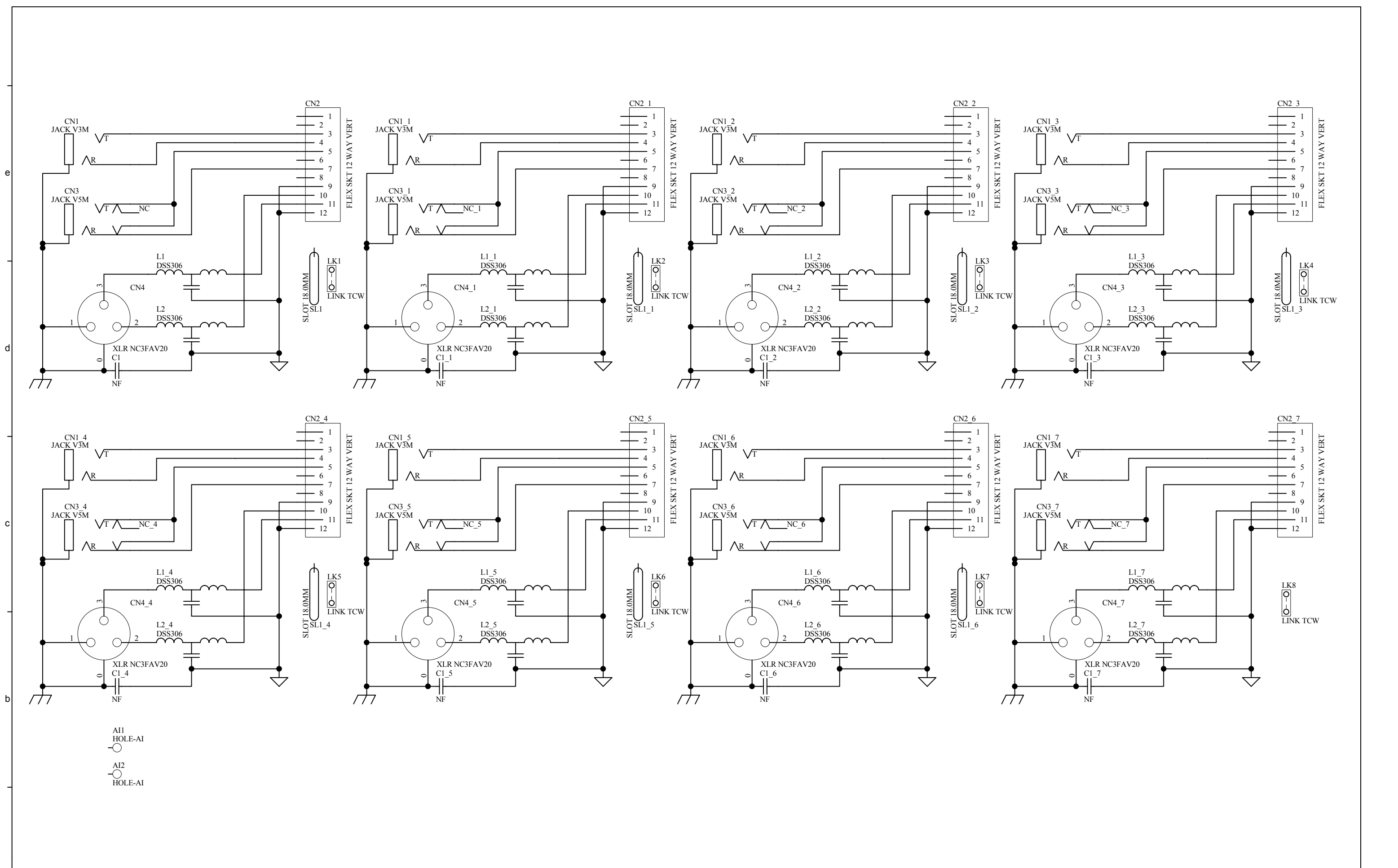

<b>ALLEN&amp;HEATH</b> Kernick Industrial Estate, Penryn, Cornwall, England. TR10 9LU Tel: +44 (0)8707 556250 Fax: +44 (0)8707 556251	ISSUE	BY	DATE	TITLE: ML3000 MONO CONNECTOR PCB PAGE: DRG No: C4455 ISSUE: 1.1 SHEET: 1 OF 1
	A	AAT	29-05-01	
	B	AAT	14-06-01	
	1	AAT	16-08-01	
	1.1	DWD	14-01-02	
FILE: C4455_1.1P1.Sch		PRINTED: 09:26:22 14-Jan-2002		

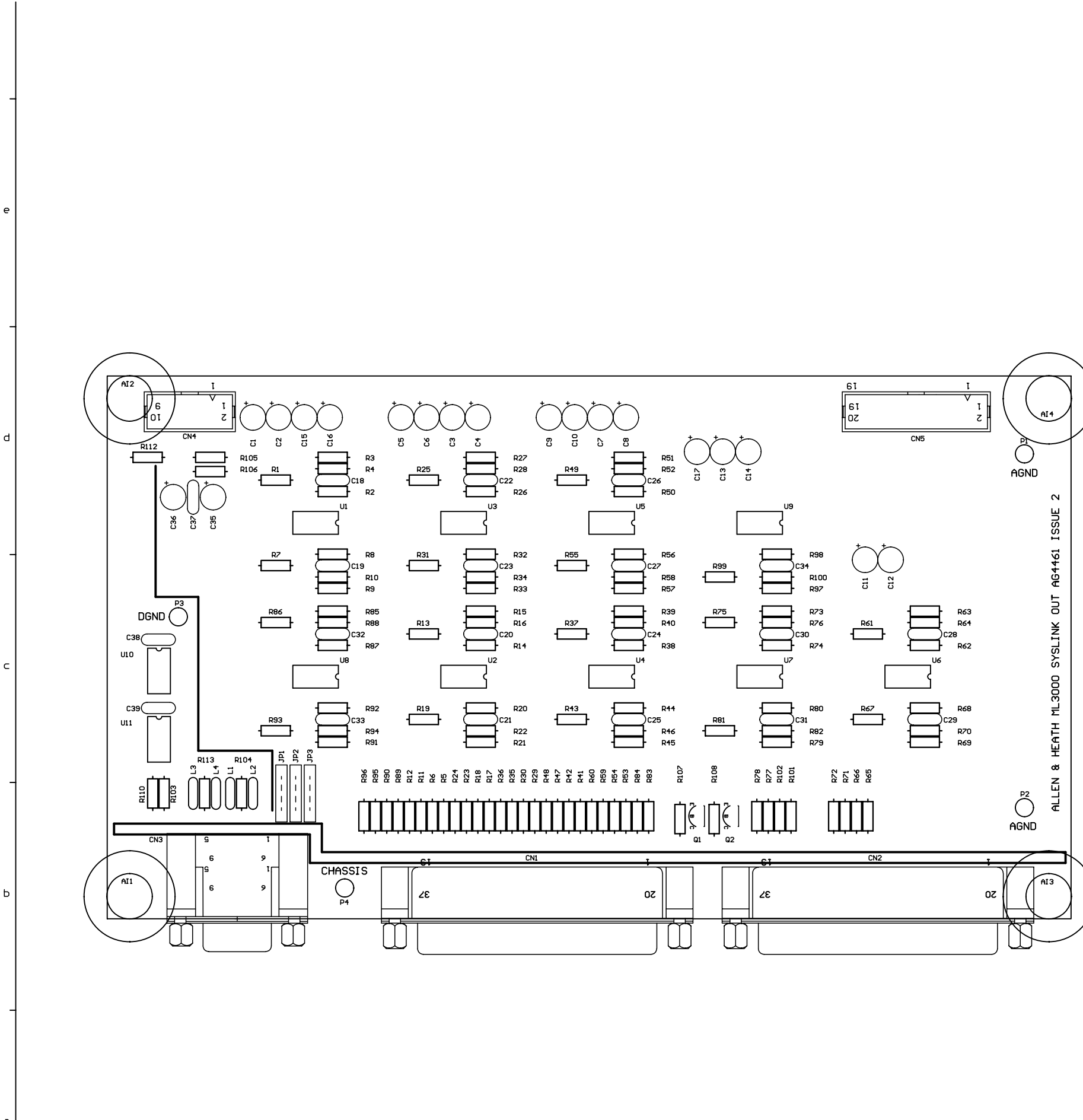

ALLEN & HEATH ML3000 SYSLINK OUT AG4461 ISSUE 2

**ALLEN & HEATH**  
 Kernick Industrial Estate,  
 Penryn, Cornwall,  
 England, TR10 9LU  
 Tel: +44 (0)8707 556250  
 Fax: +44 (0)8707 556251

TOP OVERLAY .GTO

FILE: AG4461\_2.PCB

PRINTED: 13:23:20 9-Jan-2002

TITLE:  
**ML3000 SYSLINK OUT PCB**

DRG No: AG4461 ISSUE: 2

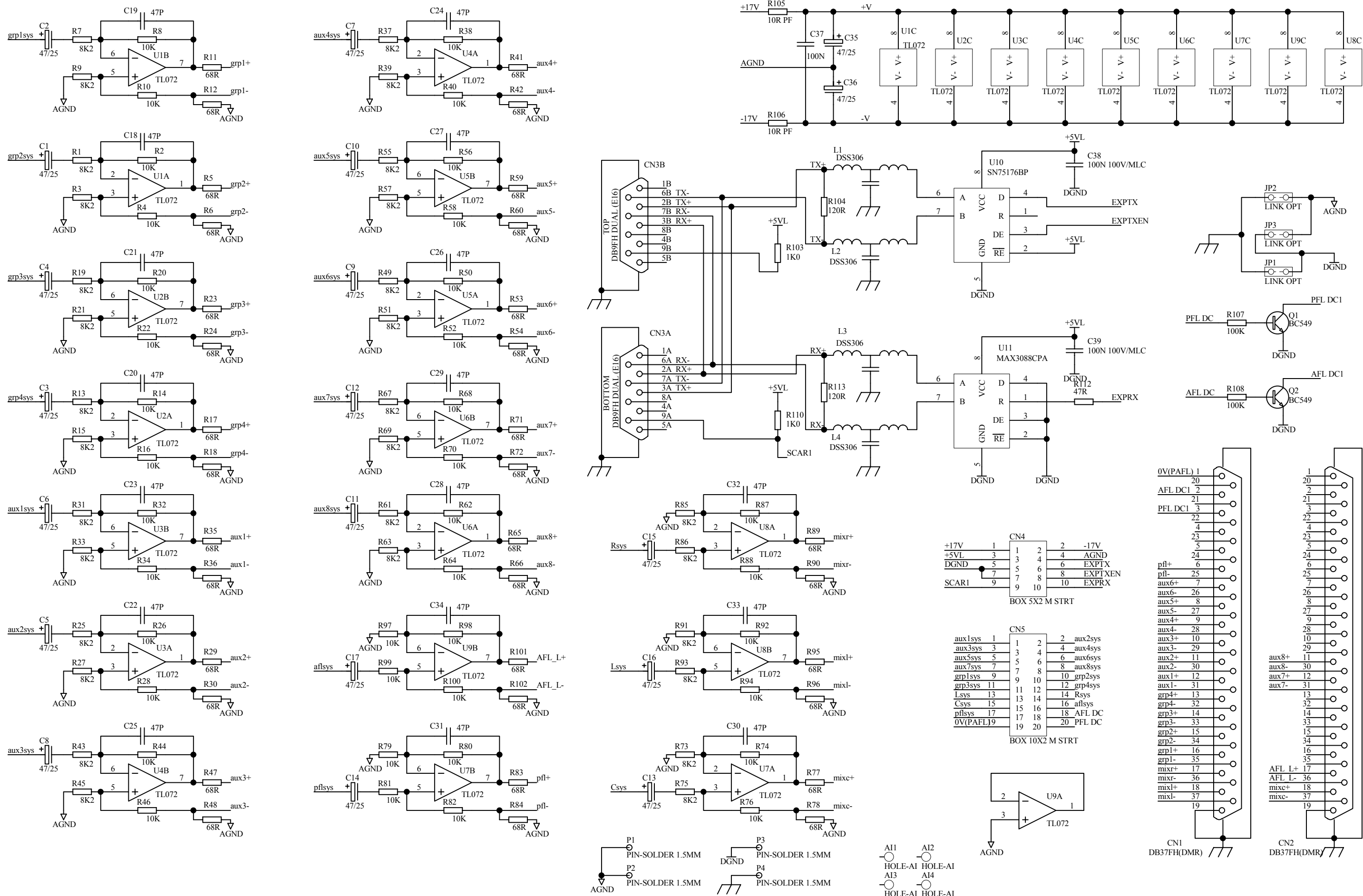

**ALLEN & HEATH**  
 Kernick Industrial Estate,  
 Penryn, Cornwall,  
 England. TR10 9LU  
 Tel: +44 (0)8707 556250  
 Fax: +44 (0)8707 556251

ISSUE	BY	DATE
A	JB	26/7/01
1	JB	11/10/01
2	AAT	31/10/01

FILE: C4461_2.Sch	PRINTED: 13:36:02	9-Jan-2002
-------------------	-------------------	------------

TITLE: **ML3000 SYSLINK OUT**  
 PAGE:  
 DRG No: **AG4461** ISSUE: **2** SHEET: **1 OF 1**

e  
d  
c  
b  
a

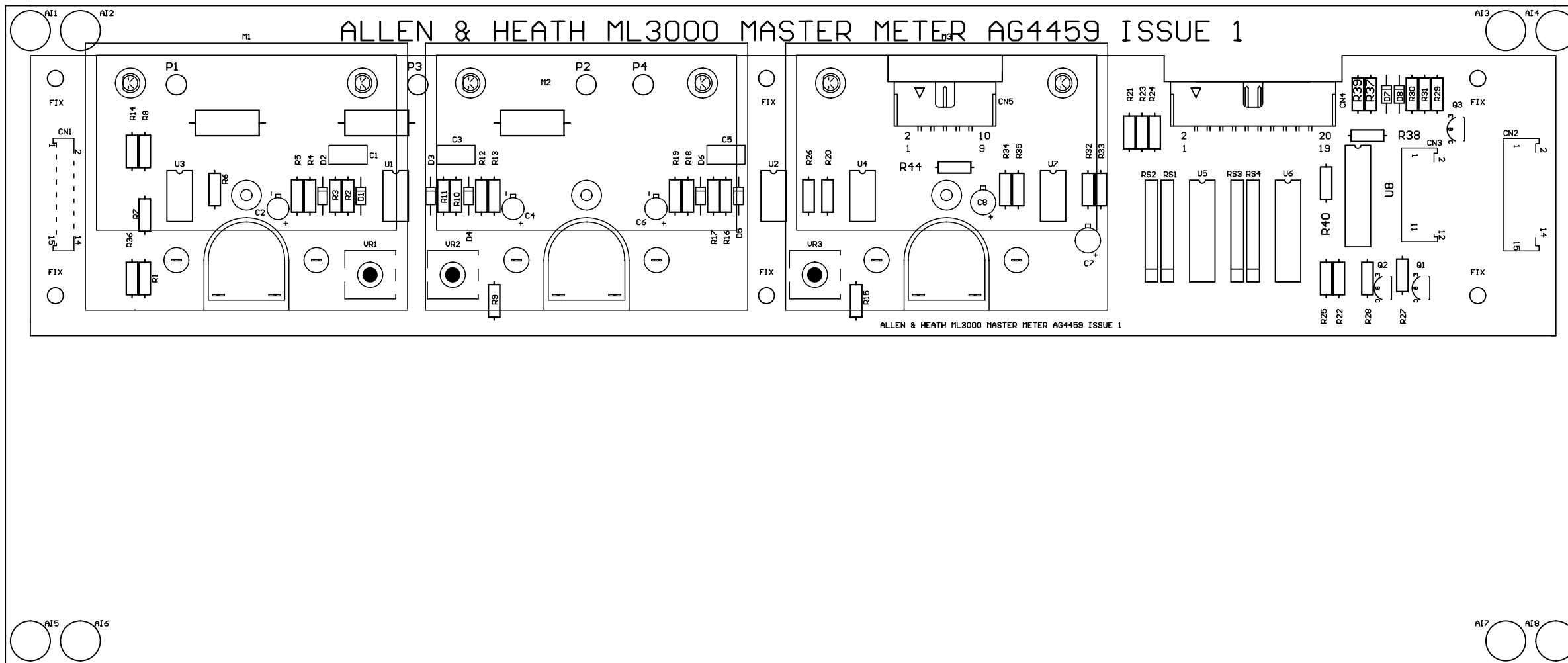

**ALLEN & HEATH**  
 Kernick Industrial Estate,  
 Penryn, Cornwall,  
 England. TR10 9LU  
 Tel: +44 (0)8707 556250  
 Fax: +44 (0)8707 556251

FILE: AG4459\_1.PCB

PRINTED: 14:21:33 10-Jan-2002

MECHANICAL DRAWING .DWG

TITLE: ML3000 MASTER METER

DRG No: AG4459 ISSUE: 1

ALLEN&HEATH ML3000 SERVICE MANUAL

D45

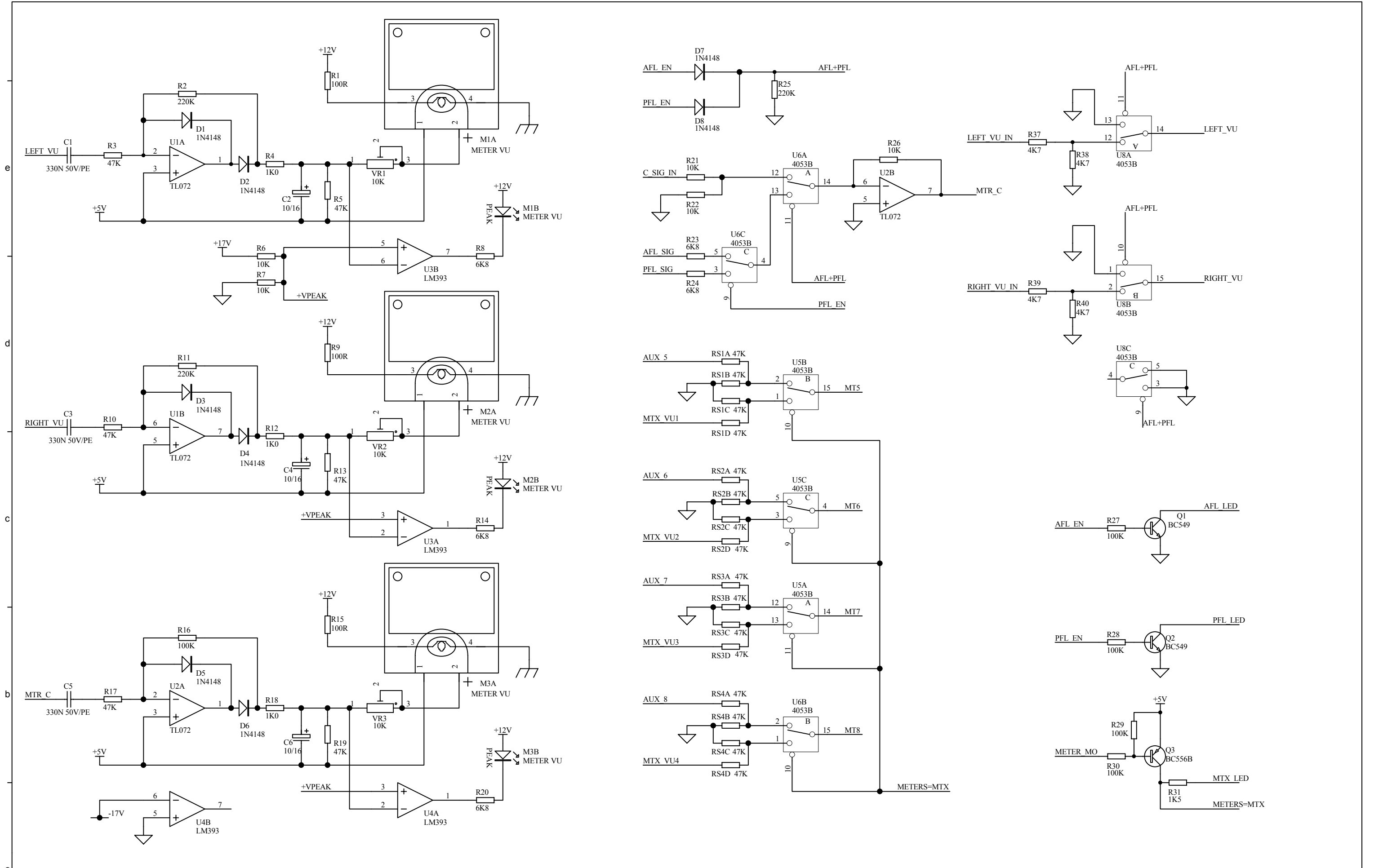

<b>ALLEN&amp;HEATH</b> Kernick Industrial Estate, Penryn, Cornwall, England. TR10 9LU Tel: +44 (0)8707 556250 Fax: +44 (0)8707 556251	ISSUE	BY	DATE	CONNECTOR CHANGES & CHANGES TO SIGNALS AT CN1  FILE: C4459_1P1.Sch    PRINTED: 09:37:07    14-Jan-2002	TITLE: <b>ML3000 MASTER METER PCB</b>
	A	JB	03-07-01		PAGE:
	B	JB	22-08-01		DRG No: <b>4459</b>
	1	MG	??-11-01		ISSUE: 1.1 SHEET: 1 OF 2
	1.1	DWD	14-01-02		

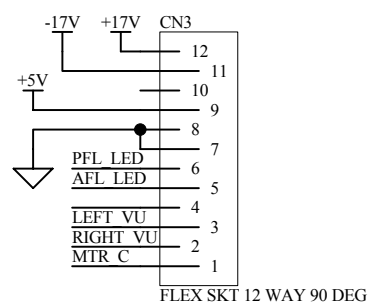
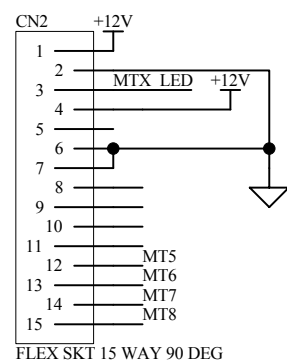
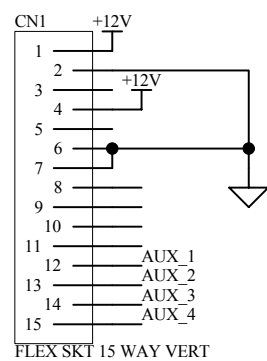
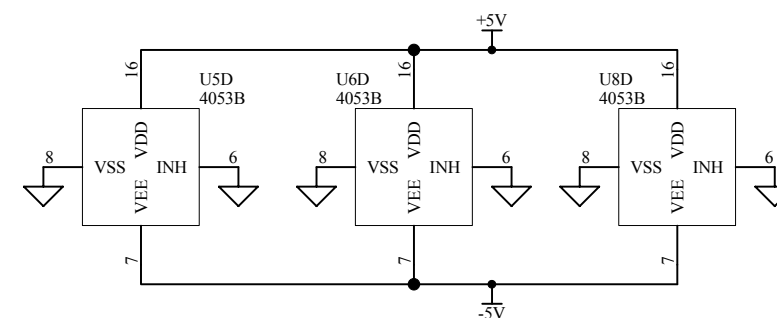
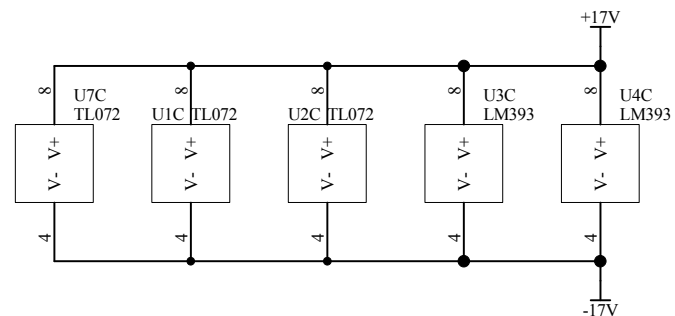
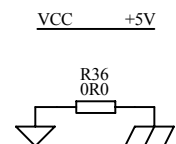
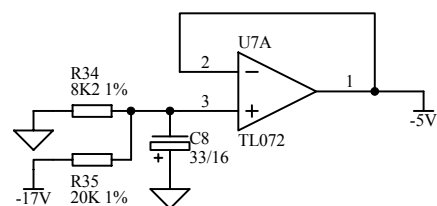
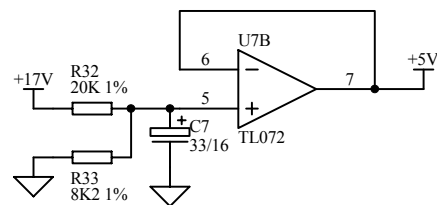

CN4  
BOX 10X2 M 90 DEG

AUX 1	1	2	AUX 2
AUX 3	3	4	AUX 4
AUX 5	5	6	AUX 6
AUX 7	7	8	AUX 8
LEFT VU IN	9	10	RIGHT VU_IN
C SIG IN	11	12	AFL SIG
PFL SIG	13	14	AFL EN
PFL EN	15	16	METER MO
MTX VU1	17	18	MTX VU2
MTX VU3	19	20	MTX VU4

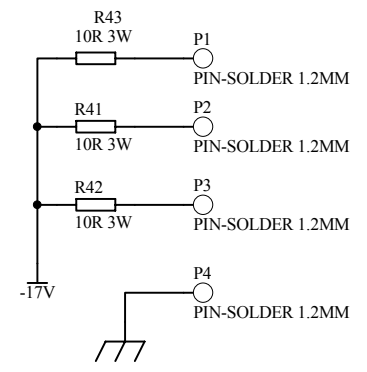
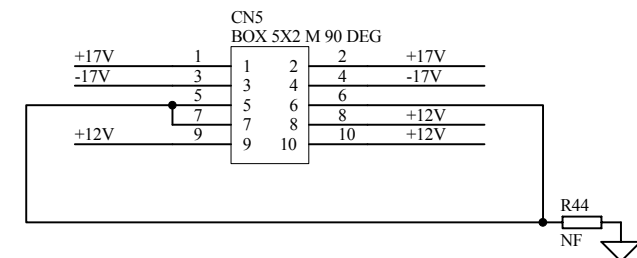

**ALLEN&HEATH**  
Kernick Industrial Estate,  
Penryn, Cornwall,  
England. TR10 9LU  
Tel: +44 (0)8707 556250  
Fax: +44 (0)8707 556251

ISSUE	BY	DATE
A	JB	03-07-01
B	JB	22-08-01
1	MG	??-11-01
1.1	DWD	14-01-02

CONNECTOR CHANGES & CHANGES TO SIGNALS AT CN1

FILE: C4459\_1P2.Sch    PRINTED: 09:38:09    14-Jan-2002

TITLE: **ML3000 MASTER METER PCB**  
PAGE:  
DRG No: **4459**    ISSUE: 1.1    SHEET: 2 OF 2



# ALLEN & HEATH ML METERS VER2 AG4676 ISS 2

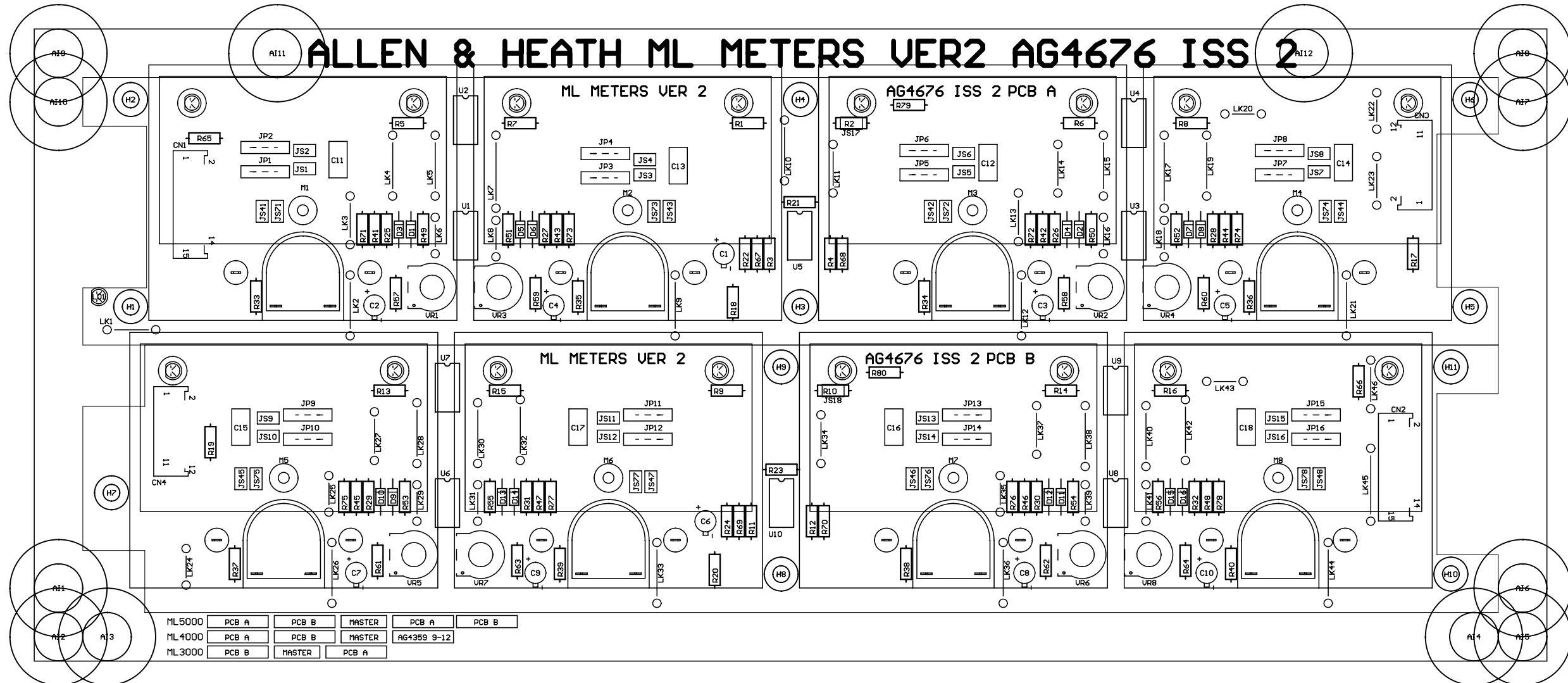

**ALLEN & HEATH**  
 Kernick Industrial Estate,  
 Penryn, Cornwall,  
 England, TR10 9LU  
 Tel: +44 (0)8707 556250  
 Fax: +44 (0)8707 556251

TOP OVERLAY .GTO

FILE: AG4676\_2.PCB

PRINTED: 12:21:00 13-Feb-2002

TITLE: ML METERS VER2 PCB

DRG No: AG4676 ISSUE: 2

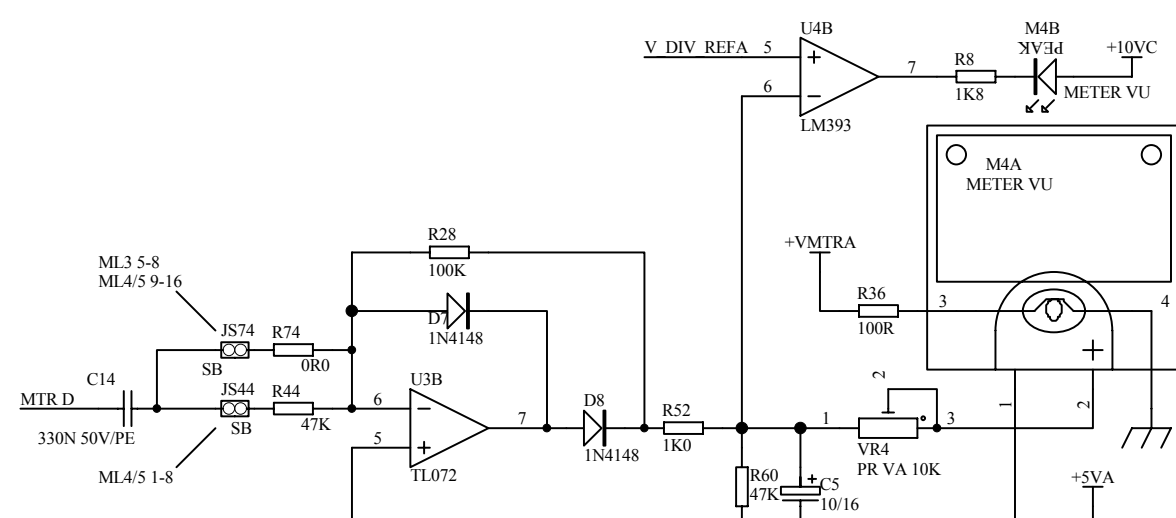
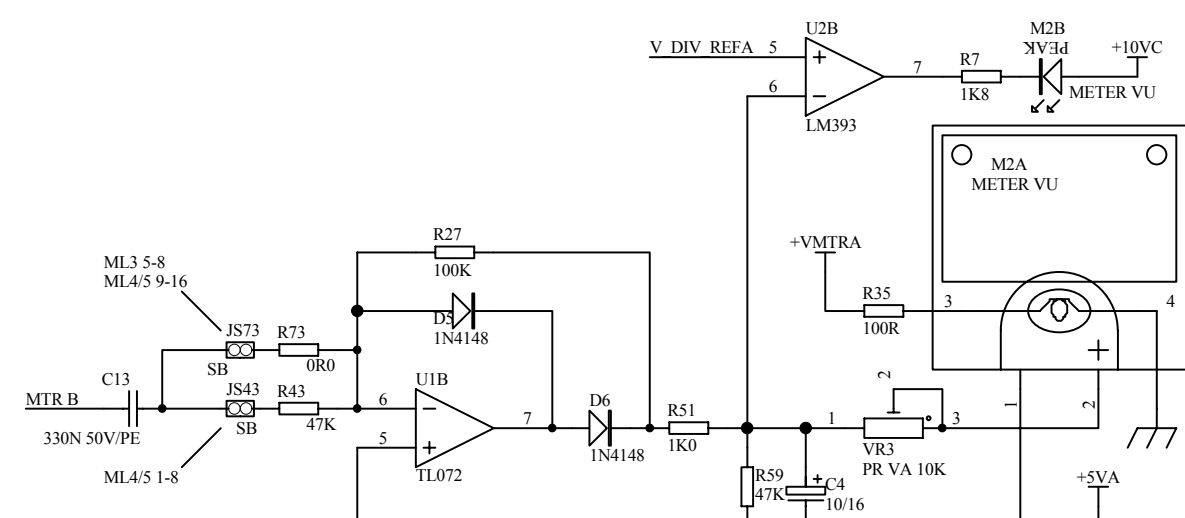
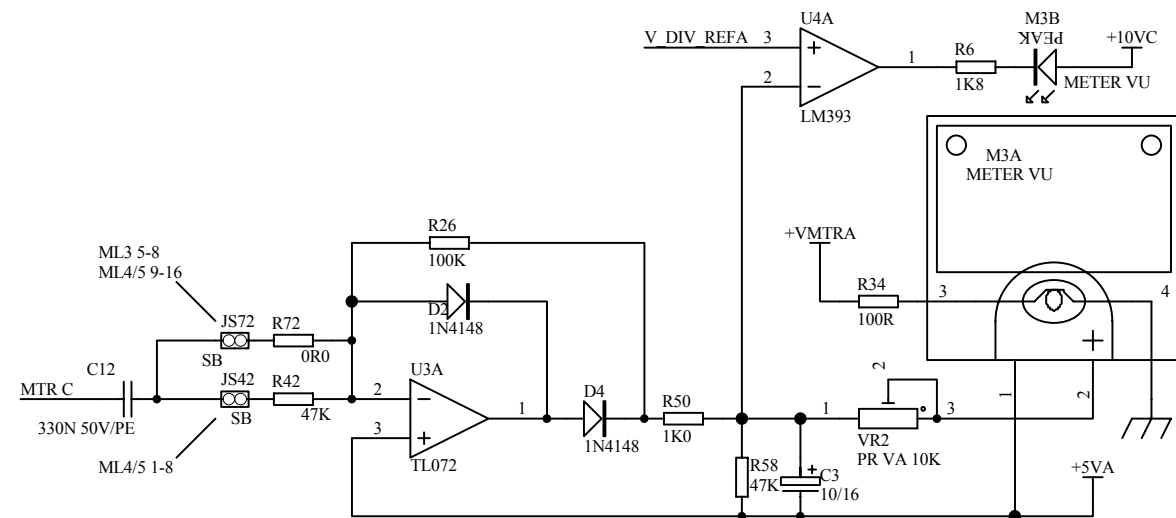
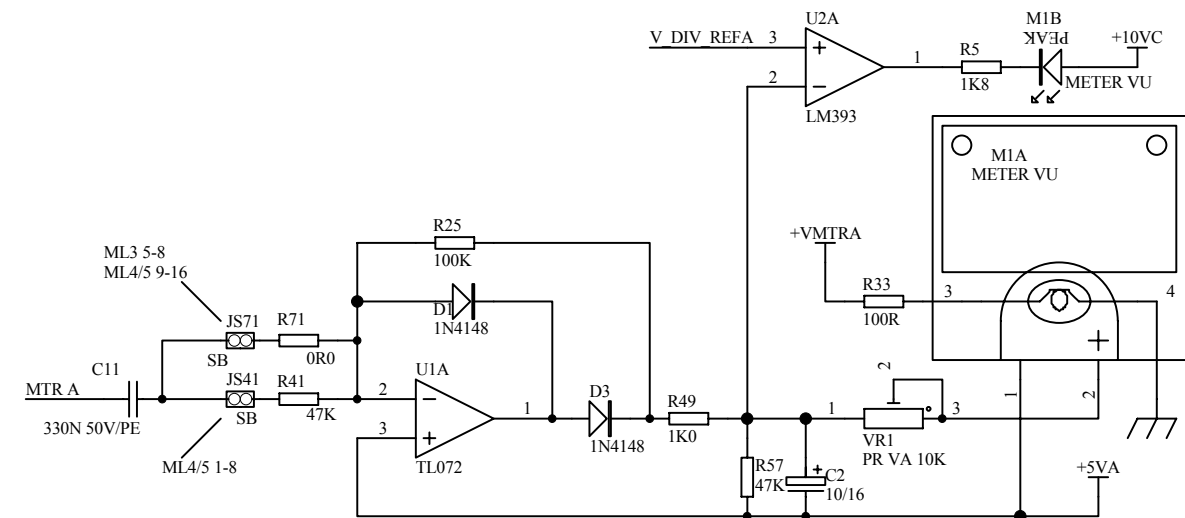
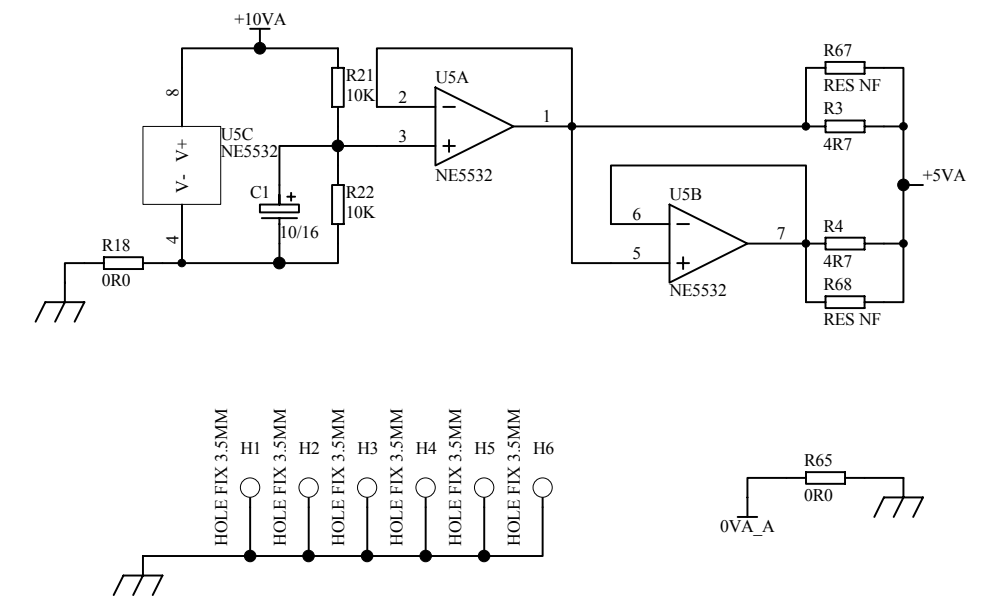
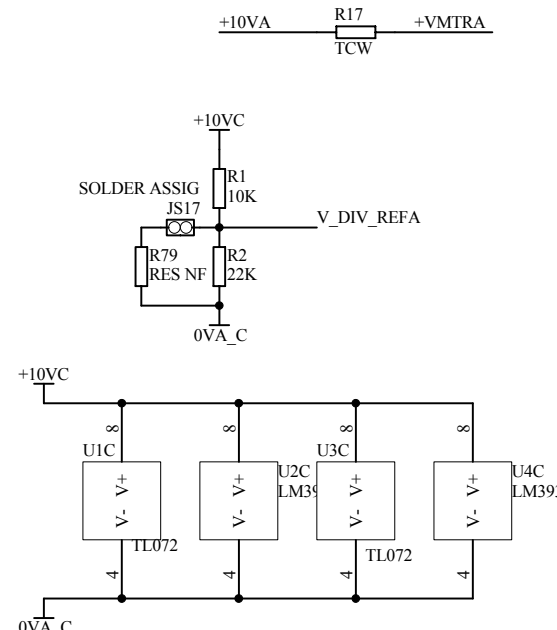
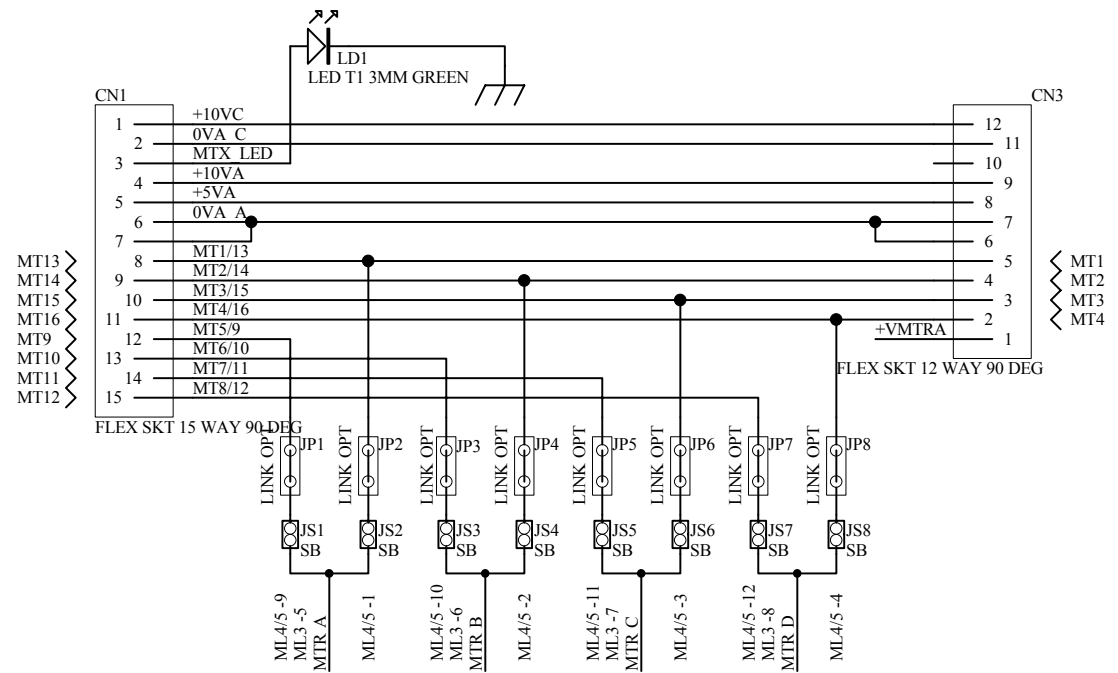

**ALLEN&HEATH**  
 Kernick Industrial Estate,  
 Penryn, Cornwall,  
 England. TR10 9LU  
 Tel: +44 (0)8707 556250  
 Fax: +44 (0)8707 556251

ISSUE	BY	DATE
1	AAT	05-10-01
2	AAT	31-10-01

FILE: C4676P2\_2.Sch PRINTED: 16:58:58 10-Jan-2002

TITLE: ML METERS 1-8 & 9-16 VER2  
 PAGE:  
 DRG No: C4676 ISSUE: 2 SHEET: 2 OF 4

METERS 1-4 & 9-12

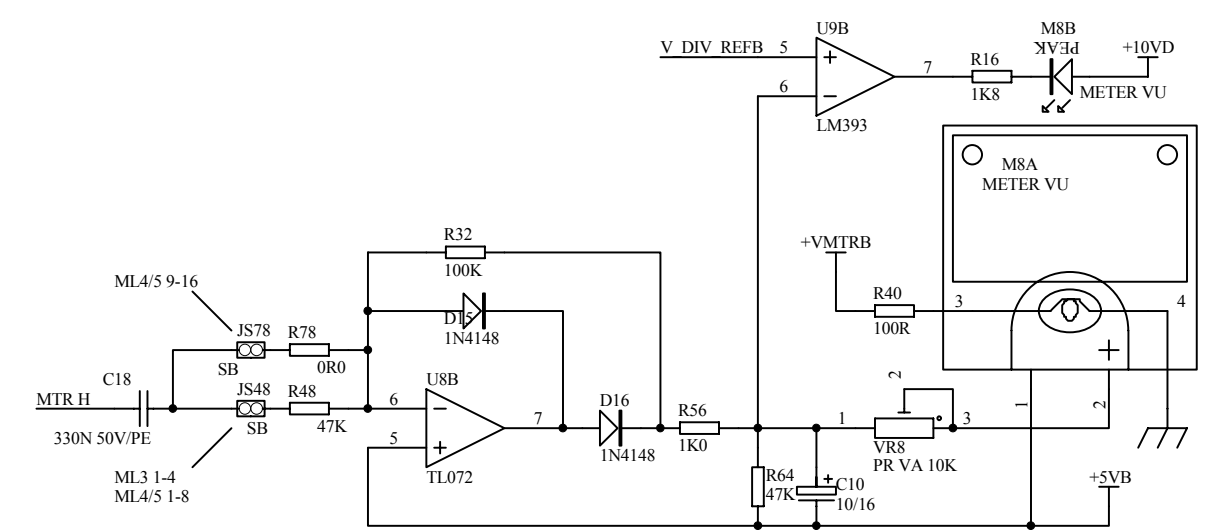
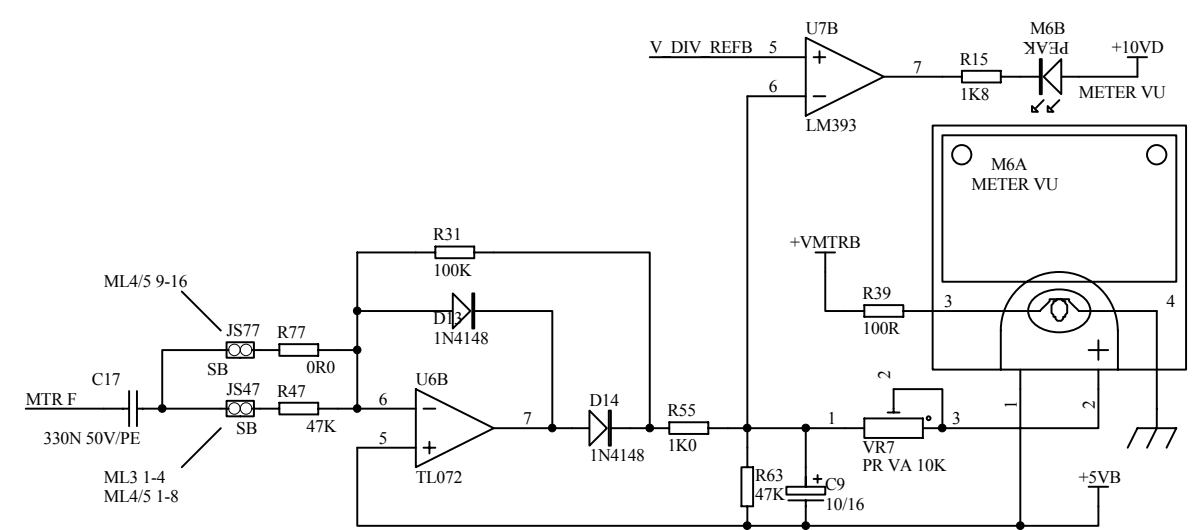
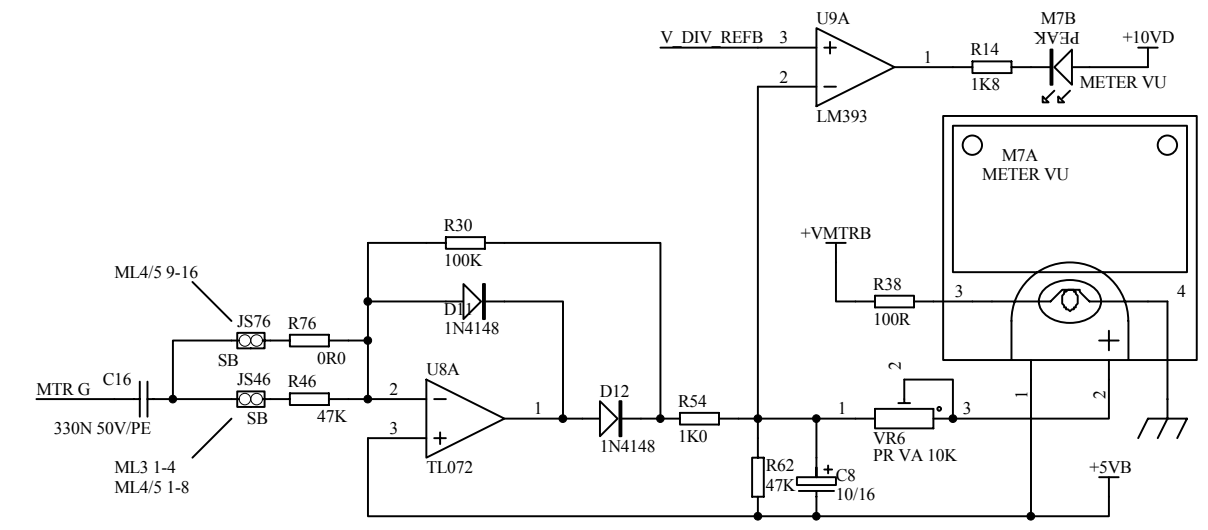
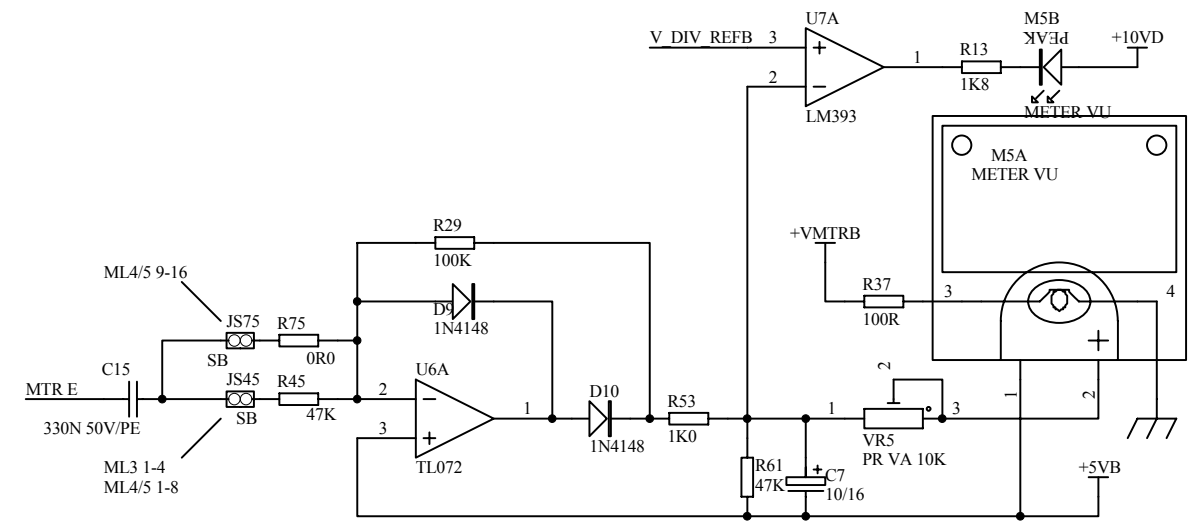
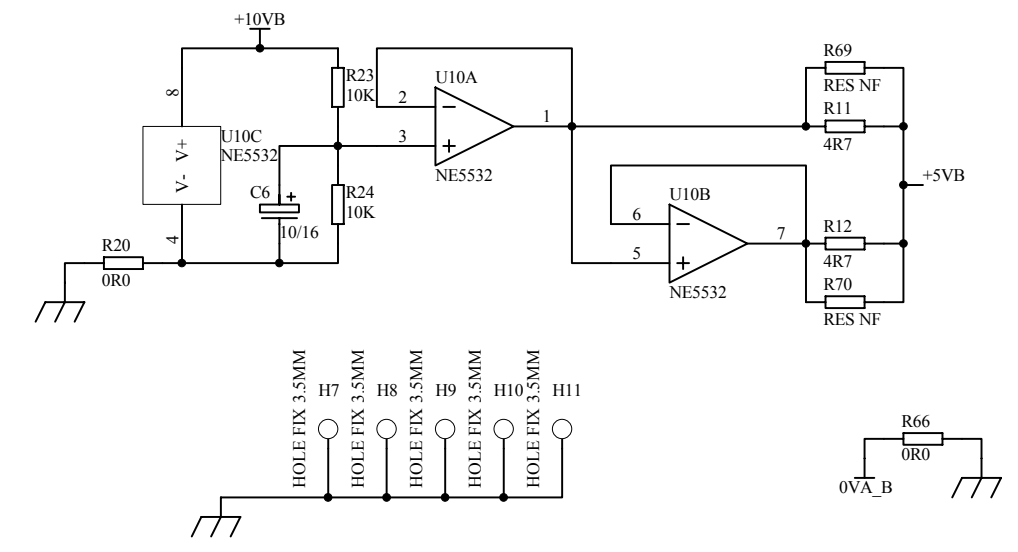
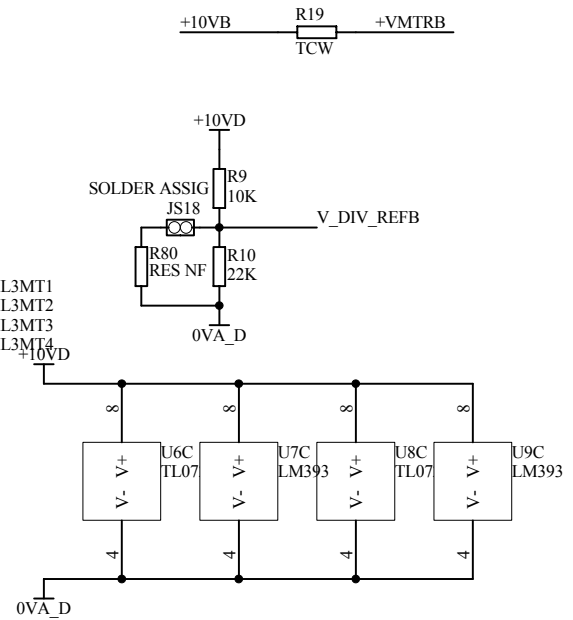
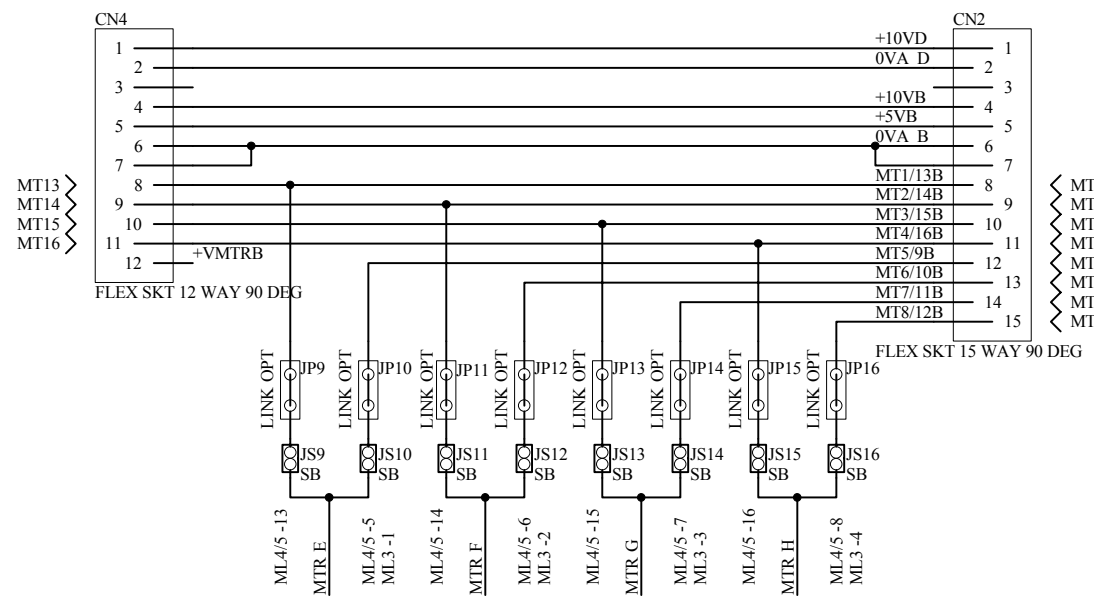

**ALLEN&HEATH**  
 Kernick Industrial Estate,  
 Penryn, Cornwall,  
 England. TR10 9LU  
 Tel: +44 (0)8707 556250  
 Fax: +44 (0)8707 556251

ISSUE	BY	DATE
1	AAT	05-10-01
2	AAT	30-10-01

FILE: C4676P3\_2.Sch    PRINTED: 17:00:27    10-Jan-2002

TITLE: ML METERS 1-8 & 9-16 VER2  
 PAGE:  
 DRG No: C4676    ISSUE: 2    SHEET: 3 OF 4

METERS 5-8 & 13-16

# ML METER LEDBARS PCB AG4356 issue 1

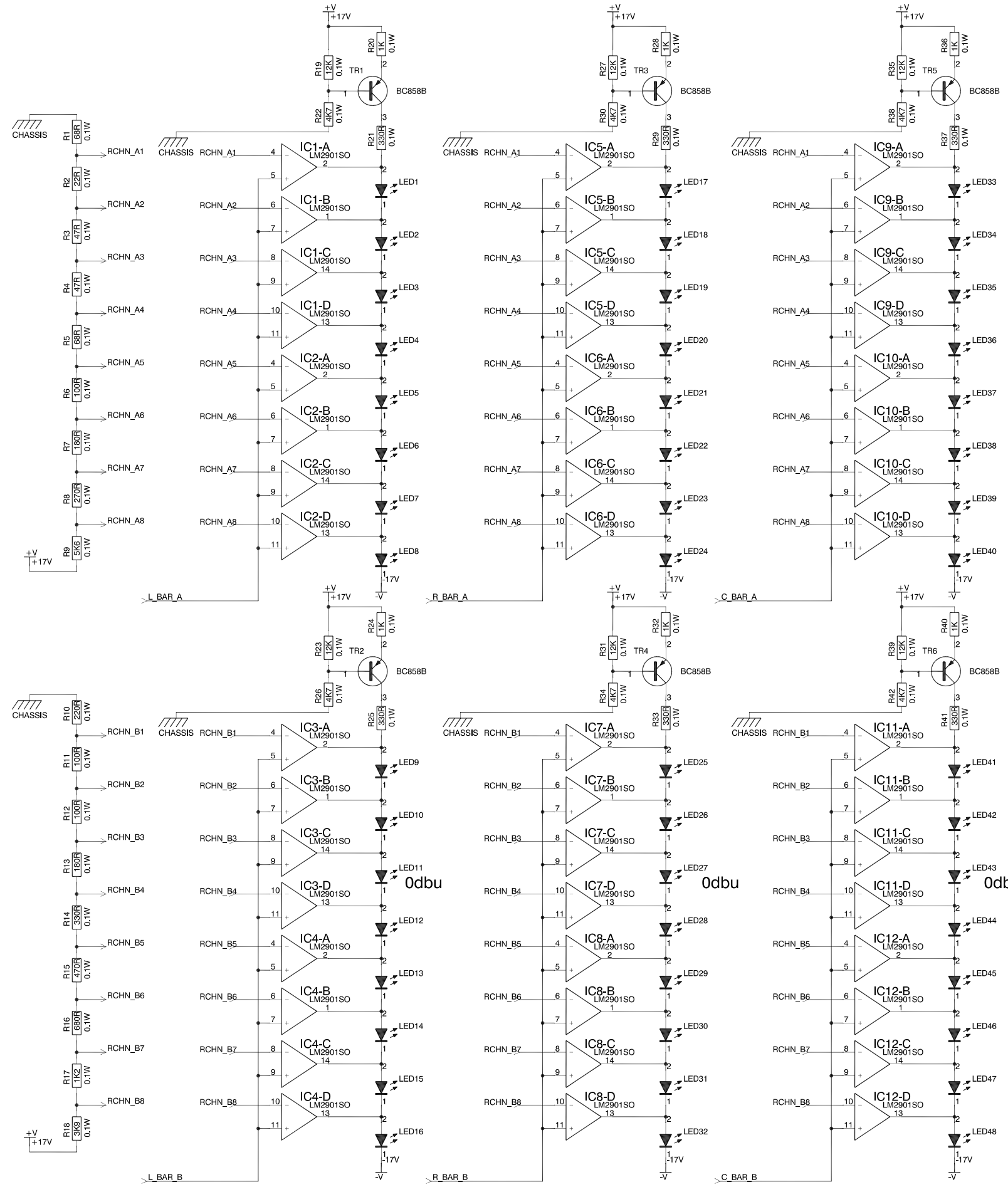
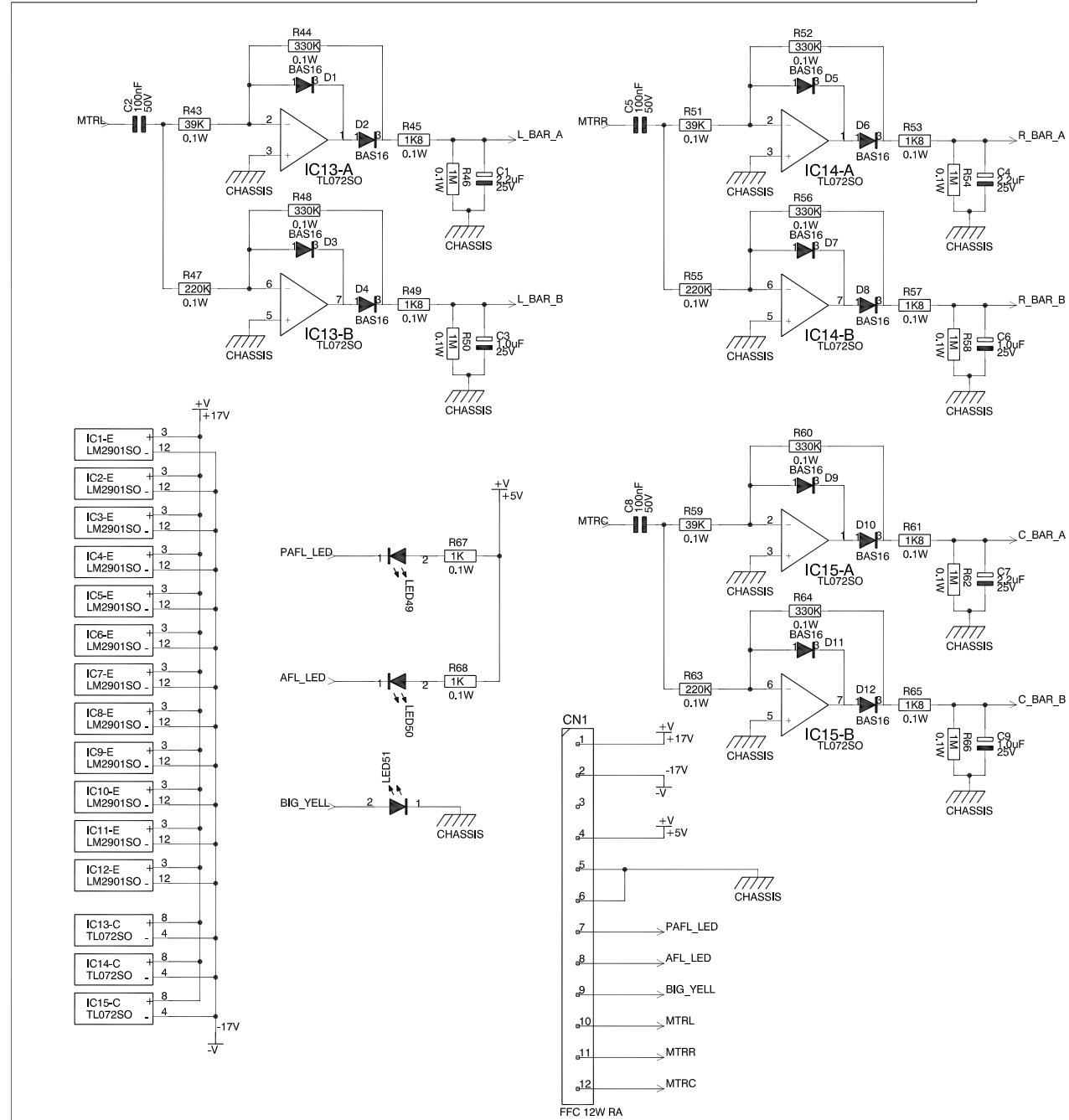
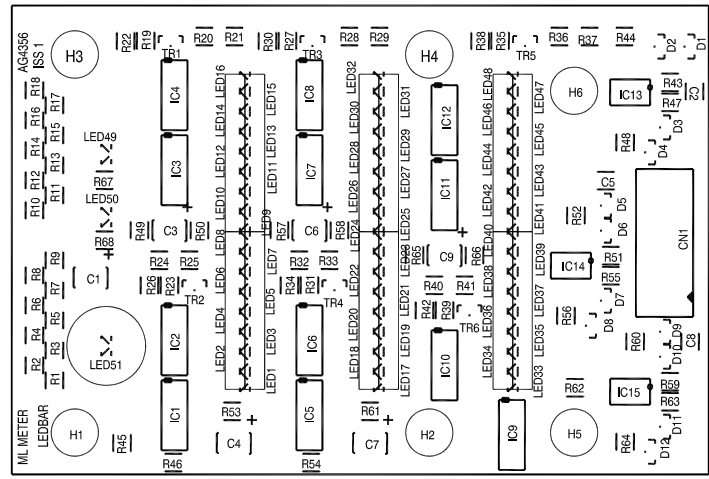

**ALLEN&HEATH**  
 Kernick Industrial Estate,  
 Perryn, Cornwall  
 England, TR10 9LU  
 Tel: (44) (0) 1326 372070 Fax: (44) (0) 1326 365736

ISS	REVISION	BY	DATE
A	ORIGIN PRODUCTION	AAT	03-01-01
		AAT	08-02-01

ML METER LEDBARS CIRCUIT C4356 issue 1 SHEET 1 of 1

A

B

C

D

E

F

G

H