

**ML  
4000**

**ALLEN&HEATH**



**Dual Function Live Sound Console**

# **SERVICE MANUAL**

Publication AP4316

# Introduction

This service manual provides technical information on the Allen & Heath **ML4000** audio console. Included is the technical specification, system block diagram, circuit schematics with board layouts, and a spare parts list. Information on the power supply is available in a separate publication. Only technically qualified service personnel should carry out service work on the console and its power supply.

Whilst we believe the information in this manual to be reliable we do not assume responsibility for inaccuracies. We also reserve the right to make changes in the interest of further product development.

We are able to offer further product support through our world-wide network of approved dealers and service agents. You can also access our Web site on the Internet for information on our product range and further technical support. To help us provide the most efficient service please keep a record of the console serial number, and date and place of purchase to be quoted in any communication regarding this product. The serial number is located on the rear panel.

Check out our home site for information on the company and its pedigree, our full product range and our design philosophy. We also have a site dedicated to the **ML Series** consoles.

[www.allen-heath.com](http://www.allen-heath.com)

[www.mlseries.com](http://www.mlseries.com)

## ML4000 Service Manual AP4316 Issue 3

Copyright © 2002 Allen & Heath. All rights reserved



This product complies with the European Electromagnetic Compatibility directives 89/336/EEC & 92/31/EEC and the European Low Voltage Directives 73/23/EEC & 93/68/EEC.

This product has been tested to EN55103 Parts 1 & 2 1996 for use in Environments E1, E2, E3, and E4 to demonstrate compliance with the protection requirements in the European EMC directive 89/336/EEC. During some tests the specified performance figures of the product were affected. This is considered permissible and the product has been passed as acceptable for its intended use.

Allen & Heath has a strict policy of ensuring all products are tested to the latest safety and EMC standards. Customers requiring more information about EMC and safety issues can contact Allen & Heath.

**NOTE:** Any changes or modifications to the console not approved by Allen & Heath could void the compliance of the console and therefore the users authority to operate it.

# ALLEN&HEATH

Manufactured in the United Kingdom by Allen & Heath

Kernick Industrial Estate, Penryn, Cornwall, TR10 9LU, UK

<http://www.allen-heath.com>

# Contents

---

Important Safety Instructions .....	4	BLOCK DIAGRAM.....	M1
Mains Plug Wiring Instructions.....	5	INTERNAL ASSEMBLY MAP .....	M2-M3
General Precautions.....	5	MONO INPUT .....	D1-D4
<b>ML4000</b> Key Features .....	6	STEREO INPUT .....	D5-D8
Front Panel Layout .....	7	MASTER CONNECTOR.....	D9-D10
Rear Panel Layouts.....	8	GROUP 1,3,5,7 .....	D11-D13
Technical Specifications.....	9	GROUP 2,4,6,8 .....	D14-D17
System Block Diagram .....	10	AUX 9 .....	D18-D21
Installation Details.....	12	AUX 10 .....	D22-D25
Earthing.....	13	AUX 11 .....	D26-D29
Audio Connector Types and Wiring .....	14	AUX 12 .....	D30-D33
Gain Structure.....	15	MASTER DISTRIBUTION.....	D34
MIDI.....	16	LRC VU METERS.....	D35-D36
Console Computer and Operating Software ....	19	LRC LED METERS.....	D37
Internal Option Links .....	20	1-12 VU METERS.....	D38-D40
Internal assembly assignments.....	20	SYSLINK INPUT.....	D41
The Range .....	21	MIDI/PSU .....	D42-D43
Ordering Spares .....	21	DC POWER WIRING.....	D44
Technical Drawings .....	22	CPU.....	D45-D48
		GRAUX SLAVE.....	D49-D50
		VCA MASTER SLAVE .....	D51
		LRC SLAVE .....	D52-D53
		MASTER FADER.....	D54
		MUTE GROUP .....	D55
		MONO FADER SLAVE.....	D56-D57
		MONO FADER .....	D58
		FADER BISCUIT (misc) .....	D59
		SYSLINK OUTPUT .....	D60-D61

# Important Safety Instructions

**WARNINGS** - Read the following before proceeding :



**ATTENTION: RISQUE DE CHOC ELECTRIQUE – NE PAS OUVRIR**

- Read instructions:** Retain these safety and operating instructions for future reference. Adhere to all warnings printed here and on the console power unit. Follow the operating instructions printed in this user guide and the power unit user guide.
- Do not remove covers:** Operate the power unit with its covers correctly fitted. Refer any service work to competent technical personnel only.
- Power sources:** Connect the power unit to a mains power only of the type described in this User Guide and marked on the rear panel. Use the power cord with sealed mains plug appropriate for your local mains supply as provided with the console. If the provided plug does not fit into your outlet consult your service agent for assistance.
- Power cord routing:** Route the power cord so that it is not likely to be walked on, stretched or pinched by items placed upon or against it.
- Grounding:** Do not defeat the grounding and polarisation means of the power cord plug. Do not remove or tamper with the ground connection in the power cord.



**WARNING: This equipment must be earthed.**

- Water and moisture:** To reduce the risk of fire or electric shock do not expose the power unit or console to rain or moisture or use it in damp or wet conditions. Do not place containers of liquids on it which might spill into any openings.
- Ventilation:** Do not obstruct the ventilation slots or position the console or power unit where the air flow required for ventilation is impeded. If the console is to be operated in a flightcase ensure that it is constructed to allow adequate ventilation.
- Heat and vibration:** Do not locate the power unit in a place subject to excessive heat or direct sunlight as this could be a fire hazard. Locate the console and its power unit away from any equipment which produces heat or causes excessive vibration.
- Servicing:** Switch off the equipment and unplug the power cord immediately if it is exposed to moisture, spilled liquid, objects fallen into the openings, the power cord or plug become damaged, during lightening storms, or if smoke, odour or noise is noticed. Refer servicing to qualified technical personnel only.
- Installation:** Install the console in accordance with the instructions printed in this User Guide. Do not connect the output of power amplifiers directly to the console. Use audio connectors and plugs only for their intended purpose.



## Important Mains Plug Wiring Instructions.

The power unit is supplied with a moulded mains plug fitted to the AC mains power lead. Follow the instructions below if the mains plug has to be replaced.

The mains lead wires are coloured in accordance with the following code:

TERMINAL		WIRE COLOUR	
		European	USA/Canada
L	LIVE	BROWN	BLACK
N	NEUTRAL	BLUE	WHITE
E	EARTH GND	GREEN & YELLOW	GREEN

The wire which is coloured Green and Yellow must be connected to the terminal in the plug which is marked with the letter E or with the Earth symbol.

**This appliance must be earthed.**

The wire which is coloured Blue must be connected to the terminal in the plug which is marked with the letter N.

The wire which is coloured Brown must be connected to the terminal in the plug which is marked with the letter L.

Ensure that these colour codes are followed carefully in the event of the plug being changed.

## General Precautions

---

- Damage :** To prevent damage to the controls and cosmetics avoid placing heavy objects on the control surface, scratching the surface with sharp objects, or subjecting the console to rough handling and vibration.
- Environment :** Protect from excessive dirt, dust, heat and vibration when operating and storing. Avoid tobacco ash, smoke, drinks spillage, and exposure to rain and moisture. If the console becomes wet, switch off and remove mains power immediately. Allow to dry out thoroughly before using again.
- Radiation :** To avoid induced noise and interference pickup do not operate the console close to strong sources of electromagnetic radiation such as power supplies, video monitors, lighting cables and dimmers.
- Cleaning :** Avoid the use of chemicals, abrasives or solvents. The control panel is best cleaned with a soft brush and dry lint-free cloth. Stubborn marks can be removed using a cloth dampened with isopropyl alcohol. Do not leave marking tape stuck to the console for long periods of time as the adhesive can degrade and leave a sticky residue. The faders, switches and potentiometers are lubricated for life. The use of electrical lubricants on these parts is not recommended. Refer to the power unit user guide for instructions on cleaning its ventilation filters.
- Transporting :** The console should be transported in the original packing or purpose built foam lined flightcase. Protect the control surface from damage during transit. The console is a large and heavy item. To avoid injury ensure adequate man power and precaution when lifting or moving the console.

# ML4000 Key Features

---

The Allen & Heath **ML4000** is a large format VCA equipped dual function live sound console providing many of the features of its larger brother the **ML5000**. It can be quickly configured for front-of-house (FOH) or stage monitor mixing. As one console suitable for both applications it is equally well suited to installation, rental and touring. It offers an IO capability and feature set that satisfies the latest trends in live sound engineering, in particular the growing number of inputs and outputs for multi-speaker house and monitor systems, demands of stereo in-ear monitoring, 3 speaker LCR imaging, advanced grouping and automation. The design ensures on-the-road durability, a clear layout for easy walk up and go operation, and no-compromise audio performance.

## Inputs and Outputs

- 3 Standard frame sizes: 32+2, 40+2, 48+2 (mono + dual stereo channels)
- 32, 40, 48 mono mic/line inputs with inserts and direct outputs
- 2 dual stereo line inputs
- 24 input sidecar to expand to a maximum 96 inputs
- Main Left, Right and Centre outputs with inserts, Centre configurable as the engineers monitor
- 8 Groups, 12 Auxes: Group/Aux 1-8 and Aux 9-12 with faders and inserts, Aux 1-8 with rotaries
- 11x4 Matrix
- 2-Track monitor input and recording send
- Stereo headphones and local monitors
- Talkback mic input
- ClearCom compatible intercom interface

## Groups and Automation

- 8 VCA groups with mutes and PAFL monitoring
- 8 audio groups with LCRplus™ sub grouping
- 8 mute groups
- MIDI accessible snapshot memories
- MIDI mute on/off, snapshot recall and dump in/out control
- Channels can be made safe from the automation

## Processing and Control

- 4-Band full sweep mono EQ with switched Q mids, 4-band fixed frequency stereo EQ
- Sweepable high pass filter
- LCRplus™ 3 speaker imaging system
- Protected mode switching to configure the console for FOH or monitor application
- Intelligent PAFL system with all-clear, PFL/in-place AFL, priority, auto-cancel/add mode...
- Assignable talkback and intercom
- 1kHz tone and pink noise generator for system line-up and testing
- Full console monitoring and extensive metering of inputs, mix busses and outputs

# Front Panel Layout

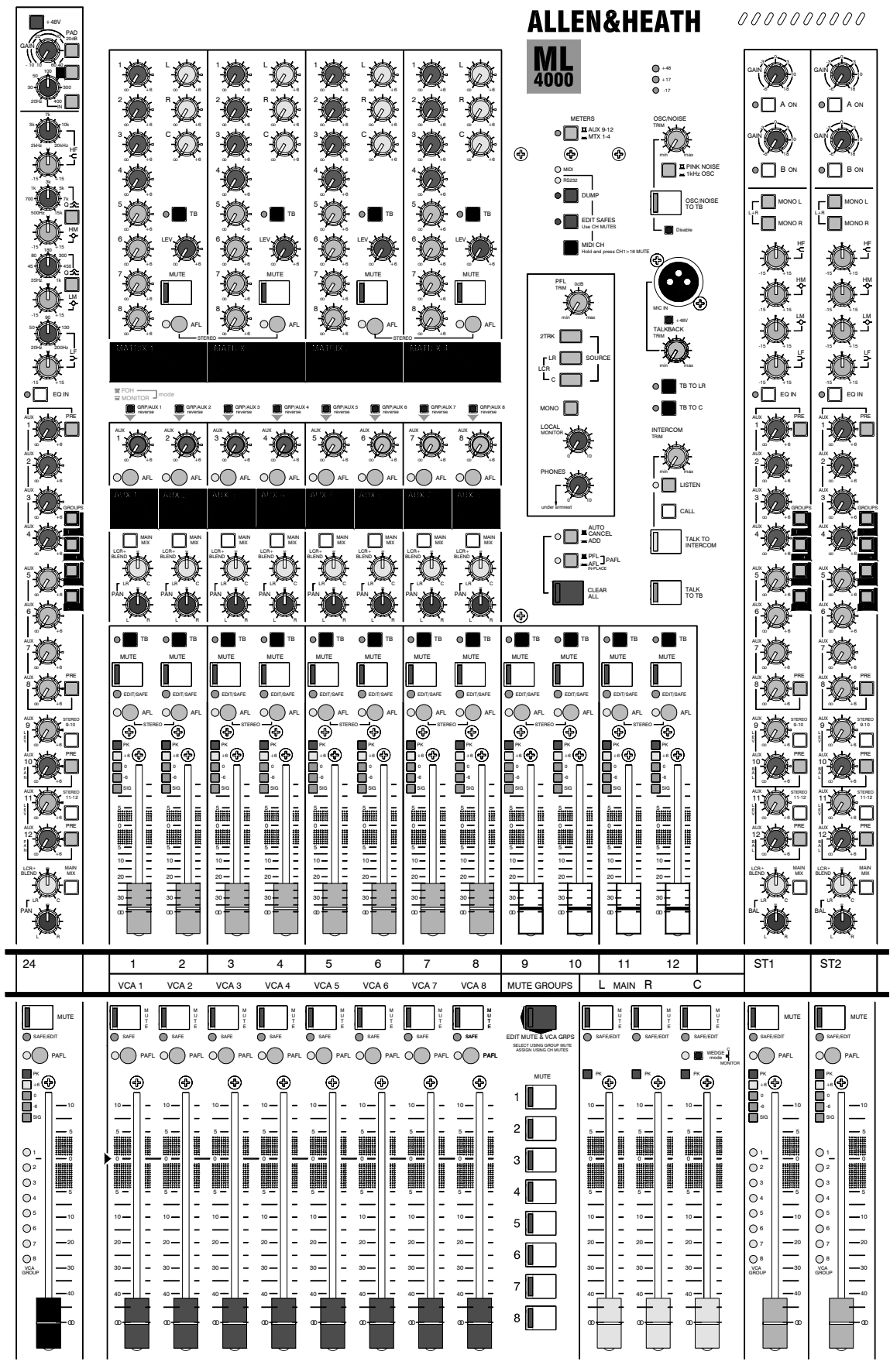

# Rear Panel Layouts

**Meterpod** Gooseneck lamp connectors.

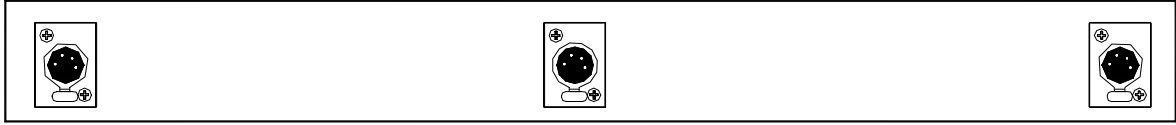

**Console** Audio, expander, intercom, power, MIDI and logic connectors.

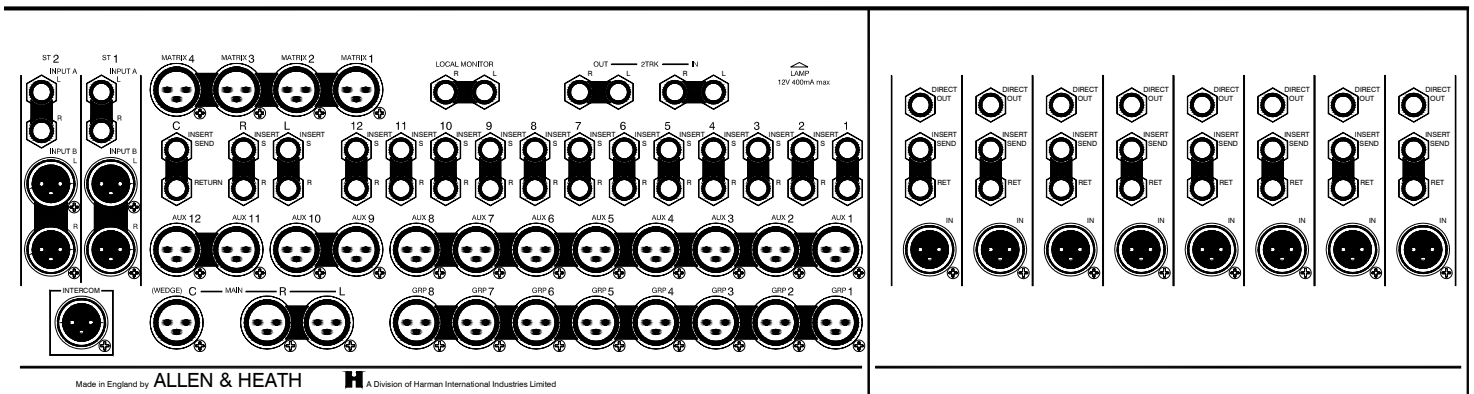
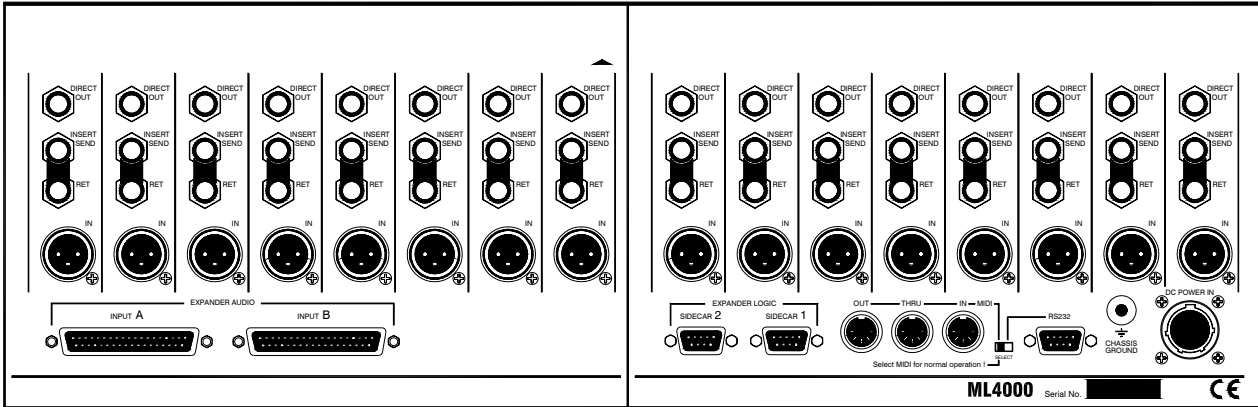

**Expander Sidecar** Audio, link to main console, power and logic connectors.

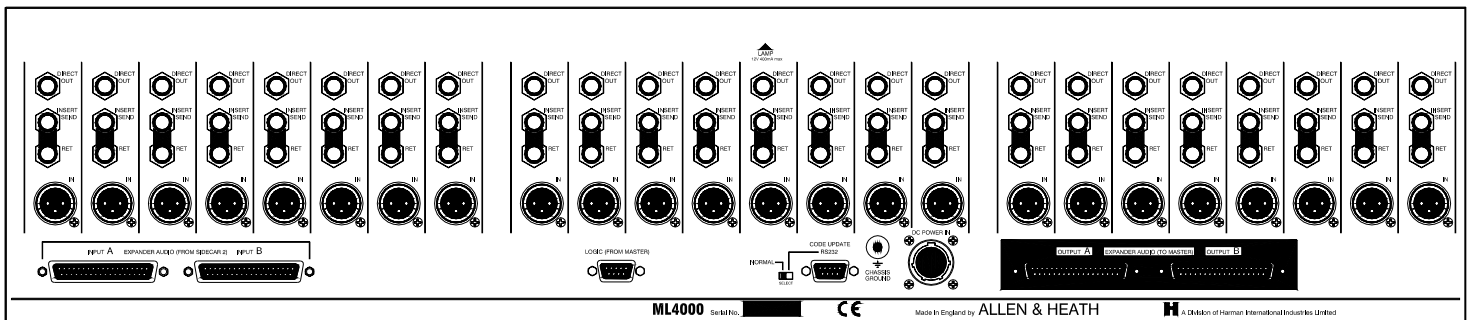



# Technical Specifications

0dBu = 0.775 Vrms, +4dBu = 1.23 Vrms

## Operating Levels

Channels ..... 0dBu Headroom +21dB  
 Mix ..... -2dBu Headroom +23dB  
 Max XLR output ..... +23dBu

## Frequency Response Referred to 1kHz at +4dBu

Mic to main output (+40dB) ..... 20Hz to 30kHz +0/-0.5dB  
 Line to main output (0dB) ..... 20Hz to 30kHz +0/-0.5dB

## Distortion @1kHz +14dBu

THD+noise ..... < 0.02%

## CMRR Common mode rejection @1kHz

Mic (+40dB) ..... > 80dB  
 Mic + Pad (0dB) ..... > 50dB

## Crosstalk Referred to driven channel @1kHz

Channel to channel ..... < -95dB  
 Mute shutoff ..... < -90dB  
 Fader shutoff ..... < -90dB

## Noise Performance Measured rms 22Hz to 22kHz unweighted

Mic EIN with 150 ohm source ..... -128dB  
 Residual output noise ..... < -98dBu  
 Mix noise, nothing routed ..... < -94dBu  
 Mix noise, 24 channels routed ..... < -84dBu

## Metering

Reading 0 ..... 0dBu at XLR outputs  
 LED meters ..... Peak reading, 3 colours  
 VU meters ..... Ave reading, illuminated moving coil  
 Peak indicators ..... 5dB before clip, multi-point sensing  
 Input meters ..... 5 bar LED (signal, -6, 0, +6, peak)  
 Group mix meters ..... 5 bar LED (signal, -6, 0, +6, peak)  
 Group/Mtx meters ..... VU  
 L,R,C meters ..... VU and 16 bar LED

## Lamp Connectors x3

Connector ..... XLR-F 4pin  
 Rating ..... 12V 400mA max

## Channel Filters

Slope ..... 12dB/oct high pass  
 Frequency ..... 20Hz to 400Hz

## Mono Equaliser

HF ..... +/-15dB, 2kHz to 20kHz shelf  
 HM ..... +/-15dB, 500Hz to 15kHz bell, Q = 1 or 2  
 LM ..... +/-15dB, 35Hz to 1kHz bell, Q = 1 or 2  
 LF ..... +/-15dB, 20Hz to 200Hz shelf

## Stereo Equaliser

HF ..... +/-15dB, 12kHz shelf  
 HM ..... +/-15dB, 2.5kHz bell  
 LM ..... +/-15dB, 250Hz bell  
 LF ..... +/-15dB, 60Hz shelf

## Power Supply Model MPS14

Type ..... External 2U rack or floor mount  
 Mains input ..... 100-230V 50/60Hz universal input  
 Power consumption ..... 500W  
 Full protection and fan cooling  
 Built-in combiner for redundant supply

## Dimensions

	Width	Depth	Height
24 Channel	1196 (47")	781 (30.7")	282 (11.1")
32 Channel	1451 (57")	781	282
40 Channel	1706 (67")	781	282
48 Channel	1961 (77")	781	282
Sidecar	831 (33")	781	282
MPS14 psu	483 (19")	260 (10.2")	

## Weights

24 Channel	53 kg (116 lbs)
32 Channel	65 kg (143 lbs)
40 Channel	75 kg (165 lbs)
48 Channel	87 kg (191 lbs)
24 Sidecar	40 kg (88 lbs)
MPS14 psu	2.5 kg (5 lbs)

## INPUTS:

Mic (Pad out) ..... XLR ..... balanced, pin2+ ..... 2k ohm ..... variable -60 to -10dBu ..... Max +11dBu  
 Mic (Pad in) ..... >20k ohm ..... variable -40 to +10dBu ..... Max +31dBu  
 Stereo A ..... TRS jack ..... balanced, tip+ ..... >20k ohm ..... variable -18 to +6dBu ..... Max +27dBu  
 Stereo B ..... XLR ..... balanced, pin2+ ..... >20k ohm ..... variable -18 to +6dBu ..... Max +27dBu  
 2-Track ..... TRS jack ..... balanced, tip+ ..... >20k ohm ..... +4dBu ..... Max +25dBu

## INSERTS:

Input send ..... TRS jack ..... ground comp, tip+ ..... <50 ohm ..... 0dBu ..... Max +21dBu  
 Input return ..... TRS jack ..... balanced, tip+ ..... >20k ohm ..... 0dBu ..... Max +21dBu  
 Output send ..... TRS jack ..... ground comp, tip+ ..... <50 ohm ..... -2dBu ..... Max +21dBu  
 Output return ..... TRS jack ..... balanced, tip+ ..... >20k ohm ..... -2dBu ..... Max +21dBu

## OUTPUTS:

L,R,C ..... XLR ..... balanced, pin2+ ..... <75 ohm ..... 0dBu ..... Max +23dBu  
 Grp/Aux 1-12 ..... XLR ..... balanced, pin2+ ..... <75 ohm ..... 0dBu ..... Max +23dBu  
 Matrix 1-4 ..... XLR ..... balanced, pin2+ ..... <75 ohm ..... 0dBu ..... Max +23dBu  
 Direct out ..... TRS jack ..... ground comp, tip+ ..... <50 ohm ..... 0dBu ..... Max +21dBu  
 2-Track ..... TRS jack ..... ground comp, tip+ ..... <50 ohm ..... 0dBu ..... Max +21dBu  
 Local Monitor ..... TRS jack ..... ground comp, tip+ ..... <50 ohm ..... 0dBu ..... Max +21dBu  
 Headphones ..... TRS jack ..... tip left, ring right ..... for stereo headphones >30 ohms

# System Block Diagram

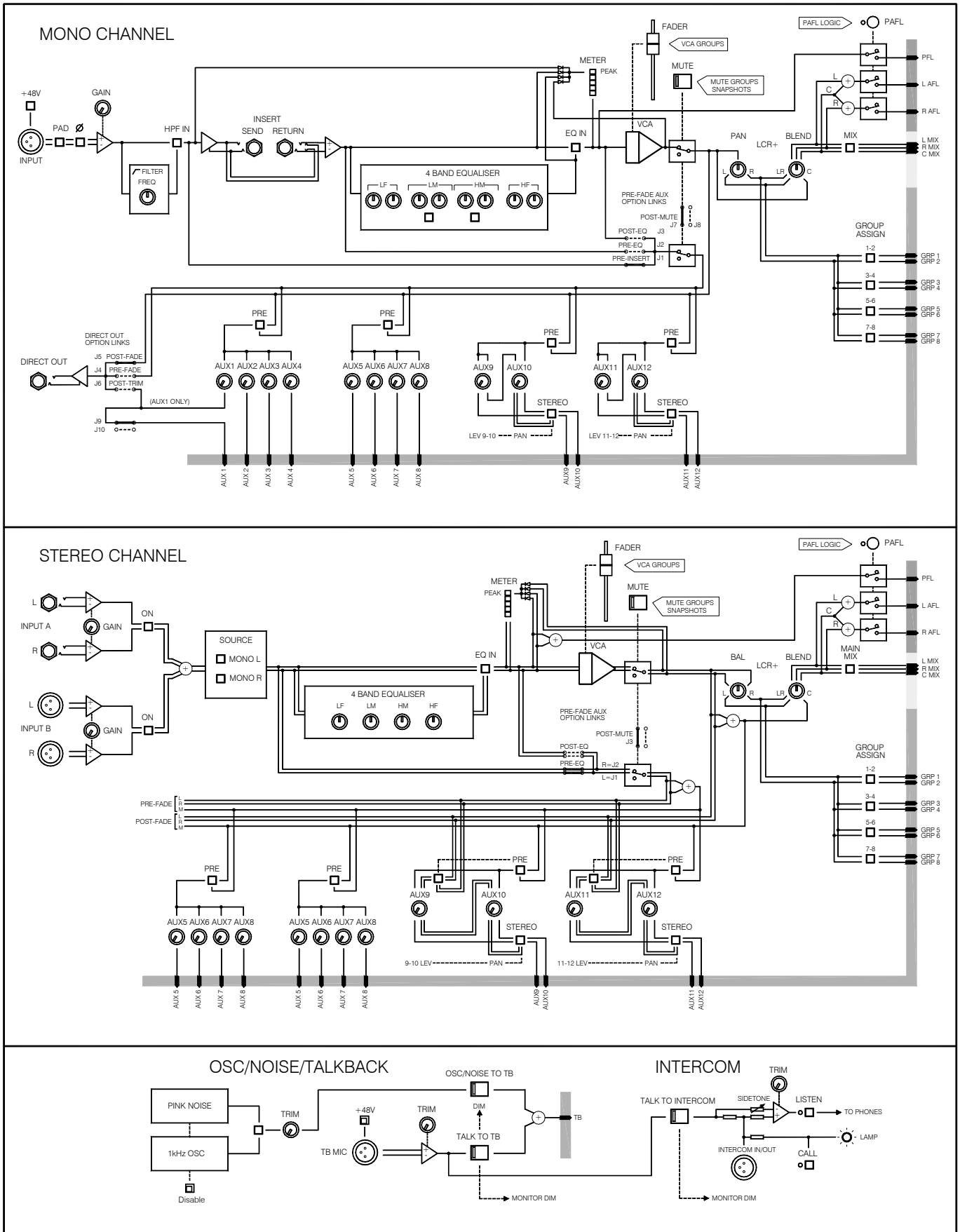

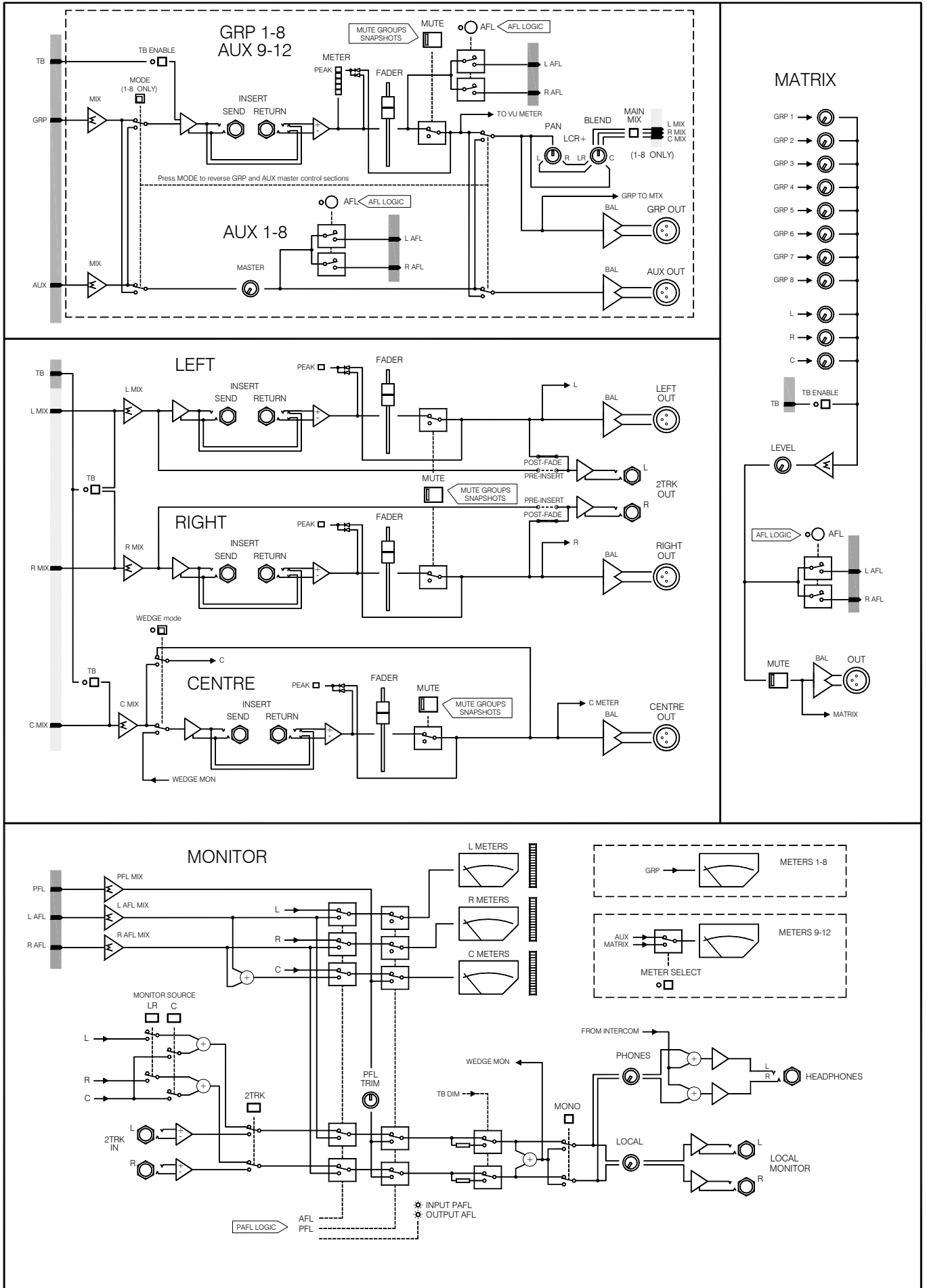

# Installation Details

Weights	24 Channel	53 kg (116 lbs)
	32 Channel	65 kg (143 lbs)
	40 Channel	75 kg (165 lbs)
	48 Channel	87 kg (191 lbs)
	24 Channel sidecar	40 kg (88 lbs)
	MPS14 psu	2.5 kg (5 lbs)

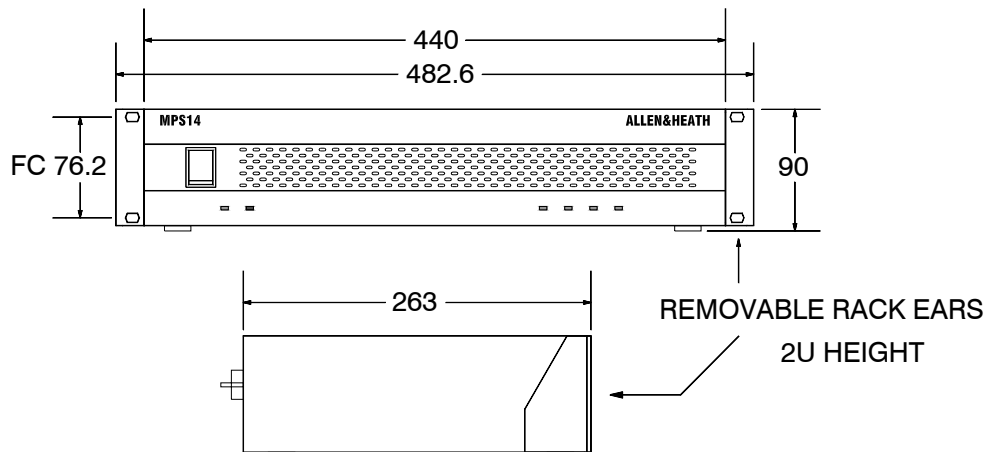
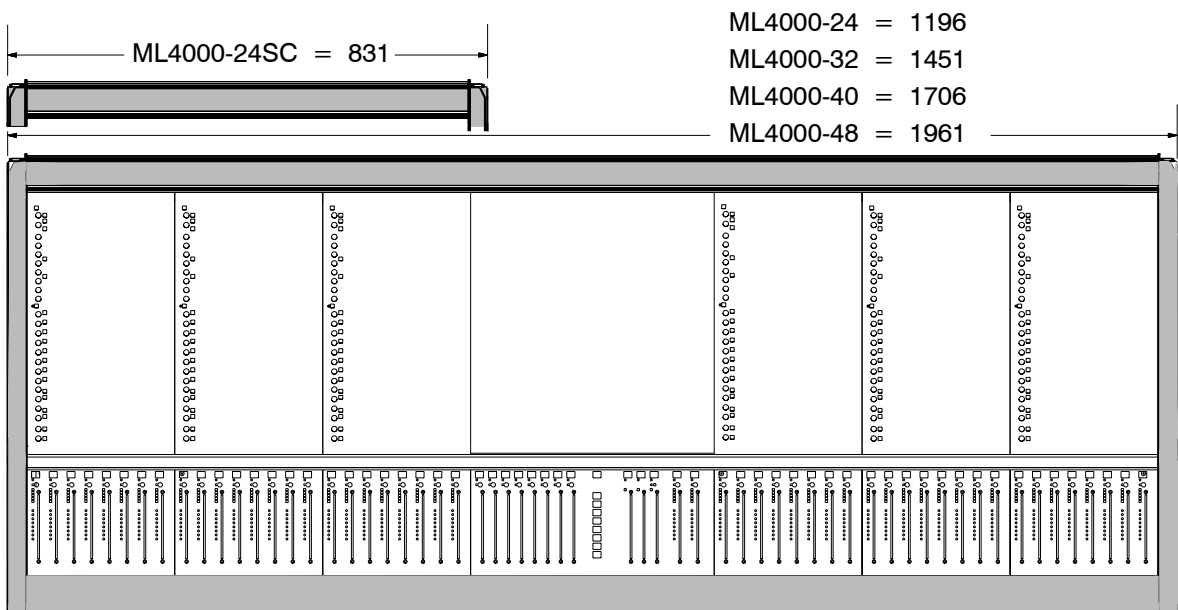
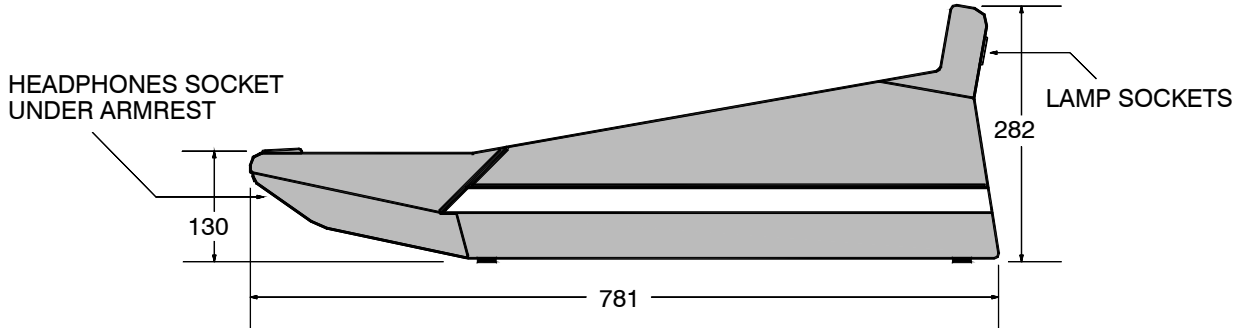

Refer to the power supply user guide for safety and installation instructions. **Heed all warnings printed in the user guide and on the power unit.**

Refer to the sidecar user guide for instructions on connecting the sidecar expander to the console.



The connection to earth (ground) in an audio system is important for two reasons:

1. **SAFETY** - To protect the operator from high voltage shock, and
2. **AUDIO PERFORMANCE** - To minimise the effect of earth (ground) loops which result in audible hum and buzz, and to shield the audio signals from interference.

For safety it is important that all equipment earths are connected to mains earth so that exposed metal parts are prevented from carrying high voltage which can injure or even kill the operator. It is recommended that the engineer check the continuity of the safety earth from all points in the system including microphone bodies, guitar strings, connector cases, equipment panels and so on.

The same earth is also used to shield audio cables from external interference such as the hum fields associated with power transformers, lighting dimmer buzz, and computer radiation. Problems arise when the signal sees more than one path to mains earth. An earth loop results causing current to flow between the different earth paths. This condition is usually detected as a mains frequency audible hum or buzz.

To ensure safe and trouble-free operation we recommend the following:

**Use a clean mains outlet for the audio system.** Keep the audio equipment mains feed separate from that powering 'dirty' equipment such as air conditioning and lighting systems, motors and vending machines.

**Use star point earthing.** It is best to install a 'star point' system where the individual earths to the equipment racks and equipment areas are separately run from a solid central reference earth point.

**Have your mains system checked by a qualified electrician.** If the supply earthing is solid to start with you are less likely to experience problems.

**Do not remove the earth connection from the console mains plug.** The console chassis is connected to mains earth through the power cable to ensure your safety. Audio 0V is connected to the console chassis internally. If problems are encountered with earth loops operate the audio 'ground lift' switch on the power supply or connected equipment, or disconnect the cable screens at one end, usually at the destination.

**Avoid induced interference.** To prevent interference pickup keep audio cables away from mains power units, cables and distribution boards, motors, lighting and computer cables and equipment, and any other heavy duty electrical equipment. Where this cannot be avoided cross the audio and 'dirty' equipment cables at right angles to minimise interference.

**Use low impedance sources** such as microphones and line level equipment rated at 200 ohms or less to reduce susceptibility to interference. The console outputs are designed to operate at very low impedance to minimise interference problems.

**Use balanced connections where possible** as these provide further immunity by cancelling out interference that may be picked up on long cable runs. To connect an unbalanced source to a balanced console input, link the cold input (XLR pin 3 or jack ring) to 0V earth (XLR pin 1 or jack sleeve) at the console. To connect a balanced console output to an unbalanced destination, link the cold output to 0V earth at the console.

**Use good quality cables and connectors** and check for correct wiring and reliable solder joints. Allow sufficient cable loop to prevent damage through stretching.

# Audio Connector Types and Wiring

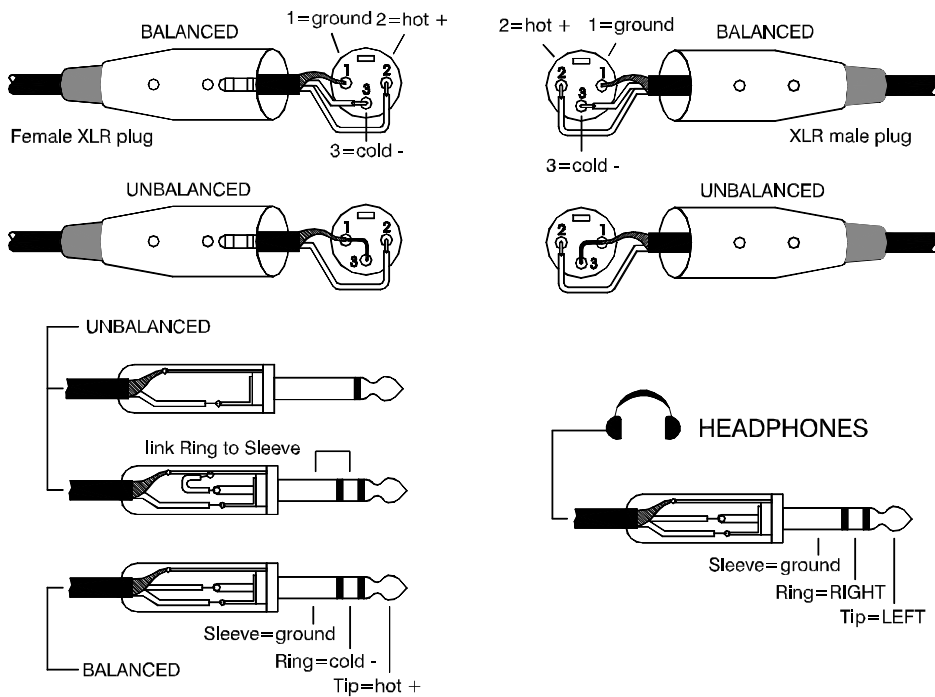
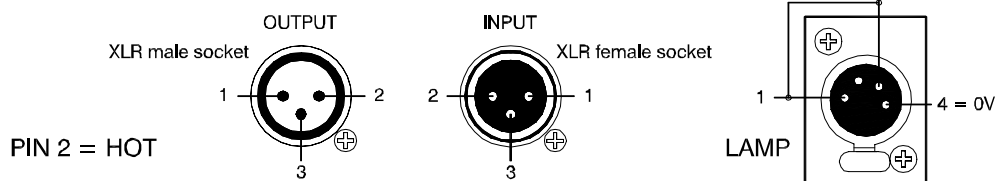
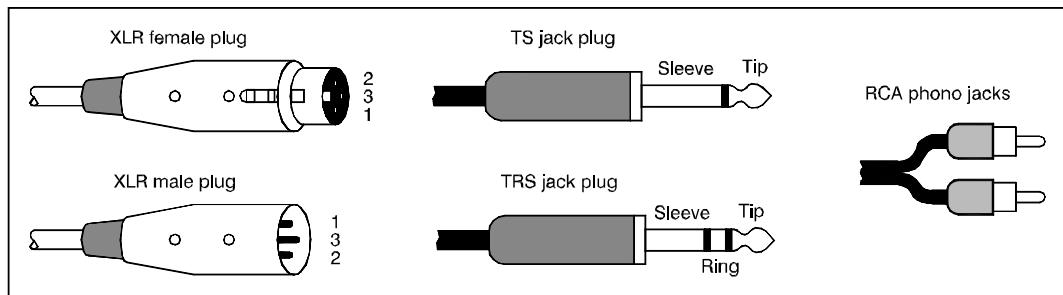

## EXPANDER INPUT

SYS-LINK II

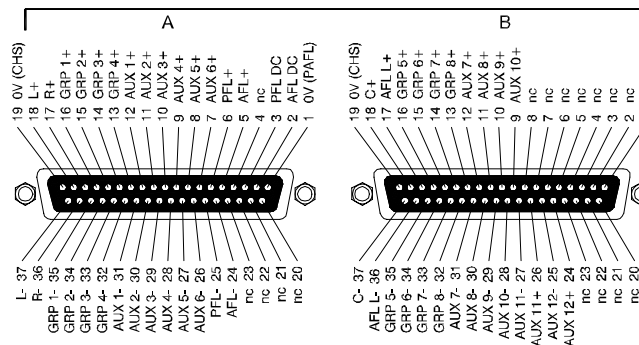

How the levels between the different signal stages are set up is referred to as the gain structure. For best performance it is important that the connected source signals are matched to the 'normal operating level' of the console. Similarly the levels of the connected amplifiers and destination equipment should be correctly matched to the console outputs. If set too high then the signal peaks will be clipped resulting in distortion, and if set too low then the signal-to-noise performance will be degraded resulting in excessive background hiss and noise.

**Using the Meters.** The **ML4000** provides metering at all important stages through the signal chain. For best results operate the console with the LED bar meters averaging around '0' allowing the loudest moments to reach '+6'. Reduce the gain if the red peak LEDs start to flash. Note that the peak leds light 5dB before actual clipping to warn that you are nearing distortion and should reduce gain. The LED bar meters have a peak response with fast attack and slow release so that fast musical transients are accurately displayed. The VU meters have a slower attack so that the average levels are better displayed. Both types of metering are useful in live sound mixing.

**Matching a Source to the Console.** Start by turning down the channel fader and send levels to prevent unexpected loud volumes reaching the main speakers and monitors. Adjust the GAIN control for an average '0' reading on the channel meter. Press PAFL (in PFL mode) to listen to the signal using headphones, local or wedge monitor, and to view its level on the main LED and VU meters. Once the gain is correctly set you can raise the levels to bring the channel into the mix. Note that you may need to adjust the gain if you make significant changes to the EQ. Make sure that any equipment inserted into the channel is set to operate around 0dBu line level. It is best to first set the gain with inserted signal processors such as compressors switched to bypass.

**Matching the Console to Destination Equipment.**

The console produces a standard XLR output level of 0dBu for a meter reading of '0'. It can produce a maximum of +23dBu and is therefore well suited to driving equipment operating at nominal 0dBu or +4dBu while providing plenty of headroom. If you are connecting directly to a sensitive power amplifier it is advisable to turn down its input trim control if the normal console level is too high. Simply turning down the console output faders degrades the output stage noise performance and reduces the resolution of the fader movement. The output faders are best operated around '-10' to '0' for loudest average volume required. This allows plenty of additional headroom if you need it.

**Terminology.** The **normal operating level** is the optimum signal level for best console performance, indicated by '0' meter readings and resulting in the 0dBu output level. The channels operate at 0dBu and the mix stages at -2dBu for extended headroom. **Headroom** is the extra level available above normal to allow for loud peaks before the signal becomes **clipped** resulting in audible distortion. The **signal-to-noise ratio** (SNR) is the difference measured in dB between normal level and residual noise floor (hiss) produced by the console electronics. The **dynamic range** is the sum of headroom and SNR representing the maximum signal range possible from quietest to loudest.

**Using the VCA Groups.** Assigning a channel to one or more VCA groups lets those group faders control the level of its VCA element. Each fader provides up to +10dB boost. Note that the channel VCA allows a maximum combined fader boost of +10dB. Any more is simply ignored. It is best to operate the VCA group faders around their nominal '0' position. You can also use a VCA group to reduce the overall level of a hot mix without having to adjust all the channel faders.

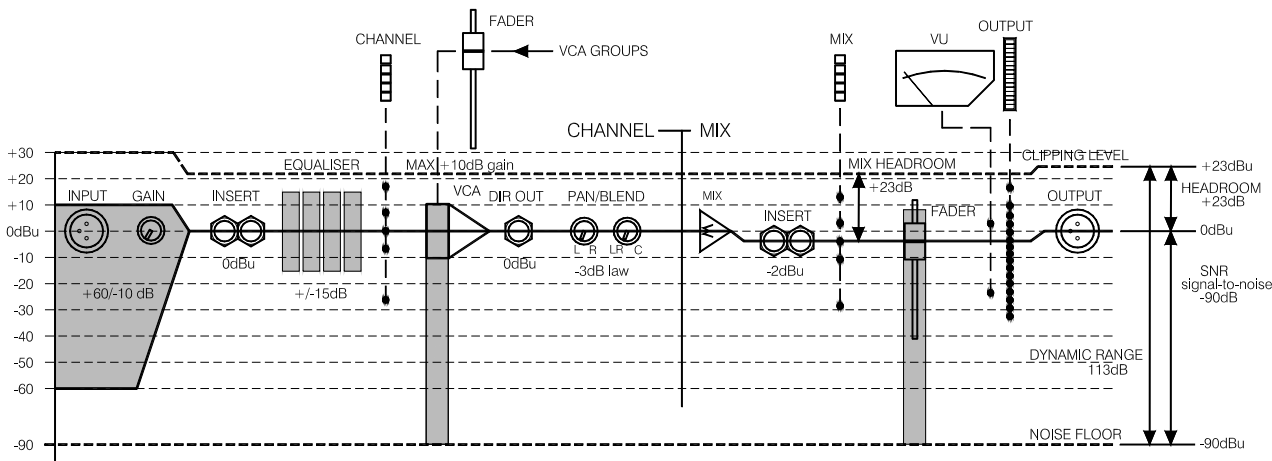

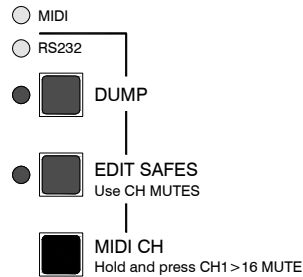

## The MIDI Cables

Use standard 5-pin 180 degree DIN type male-to-male MIDI cables. These should be available from your local audio dealer or music shop. The cables should not exceed 15 meters (50 feet) in length.

To control external equipment plug console MIDI OUT to external equipment MIDI IN. To control the console plug external equipment MIDI OUT or THRU to console MIDI in. To pass MIDI through the console to other equipment plug console MIDI THRU to equipment MIDI IN.

Make sure the same MIDI channel number is selected on the console and external equipment you want the console to communicate with.

## MIDI Overview

The **ML4000** includes a Musical Instrument Digital Interface (MIDI) port. Standard 5-pin IN, THRU and OUT sockets allow connection to external MIDI equipment such as computer show control systems, sequencers, instruments and data archiving devices. Applications include sophisticated 'hands-off' scene control, effects and instrument patch control, switching of signal processing remote controllers, and archiving of the console settings and memories for later re-use.

### What the console MIDI can do :

- ✓ Turn channel mutes on and off
- ✓ Recall snapshot memories
- ✓ Snapshot program change messages
- ✓ AFL SysEx messages for BSS & dbx controllers
- ✓ Archive console settings and memories

### What the console MIDI cannot do :

- ✗ Turn Mute Groups on and off
- ✗ Turn VCA group mutes on and off
- ✗ Assign channels to VCA groups
- ✗ Control VCA fader levels

The capabilities of the console automation system are subject to continual development and new features may be added in time. The latest operating software is available on the Allen & Heath Internet site together with loading instructions.

## Selecting MIDI Operation

For MIDI operation make sure the rear panel switch is set to the MIDI position. The RS232 setting is only used when updating the console operating software to a new version, or with the Allen & Heath ML4 Archiver utility for the PC.

## Changing the MIDI Channel Number

Hold down the master section MIDI CH key. The current MIDI channel number is displayed on one of the CH1 to 16 SAFE/EDIT LEDs. The LED flashes to attract your attention. Simply press one of the CH1 to 16 MUTE keys while holding down MIDI CH to change the MIDI channel number. The channel mute is not affected during this operation.



## Channel Mutes

Pressing any input or output channel MUTE switch transmits a MIDI Note On message. Similarly, receiving a MIDI Note On message will turn the associated channel mute on or off, unless the channel has been made automation safe.

Console mutes are mapped to MIDI Note numbers as shown in the table. Running status is supported on receive and transmit.

**Transmit.** Pressing a channel MUTE switch transmits the following Note On messages:

9n cc vv 9n cc 00

Where n = console MIDI channel number  
cc = input or output channel number  
vv = 3FH for mute off, 7FH for mute on

**Receive.** The console responds to the following MIDI Note On message:

9n cc vv (00 is ignored)

Where vv < 40 = mute off,  
40 <= vv <= 7F = mute on

## Snapshot Memories

Recalling a snapshot will transmit a MIDI Program Change message. Receiving a Program Change message will recall a snapshot.

Snapshot numbers 1 to 128 are mapped to MIDI Program Change numbers 0 to 127. Running status is supported on receive and transmit.

**Transmit and Receive.** The message format is:

Cn pp

Where n = console MIDI channel number  
pp = console snapshot number 00 to 7F

## MIDI AFL Messages

SysEx message strings are transmitted each time an output channel AFL switch is selected or released. These are for use with **BSS** and **dbx** speaker management systems to automatically select the remote control surface associated with the output being AFL monitored.

### BSS Omnidrive

F0 00 20 18 7F 20 tx\_event F7

### dbx Drive Rack

F0 00 01 1E 7F 7F 20 tx\_event F7

These messages are subject to further development and addition. Please check the Allen & Heath Web site for the latest information.

HEX	MUTE
00	GRP/AUX 1
01	GRP/AUX 2
02	GRP/AUX 3
03	GRP/AUX 4
04	GRP/AUX 5
05	GRP/AUX 6
06	GRP/AUX 7
07	GRP/AUX 8
08	AUX 9
09	AUX 10
0A	AUX 11
0B	AUX 12
0C	
0D	
0E	
0F	
10	MATRIX 1
11	MATRIX 2
12	MATRIX 3
13	MATRIX 4
14	
15	
16	
17	

HEX	MUTE
50	STEREO 1
51	STEREO 2
52	
53	
54	MAIN L
55	MAIN R
56	MAIN C

HEX	MUTE
20	CH 1
21	CH 2
22	CH 3
23	CH 4
24	CH 5
25	CH 6
26	CH 7
27	CH 8
28	CH 9
29	CH 10
2A	CH 11
2B	CH 12
2C	CH 13
2D	CH 14
2E	CH 15
2F	CH 16
30	CH 17
31	CH 18
32	CH 19
33	CH 20
34	CH 21
35	CH 22
36	CH 23
37	CH 24

HEX	MUTE
38	CH 25
39	CH 26
3A	CH 27
3B	CH 28
3C	CH 29
3D	CH 30
3E	CH 31
3F	CH 32
40	CH 33
41	CH 34
42	CH 35
43	CH 36
44	CH 37
45	CH 38
46	CH 39
47	CH 40
48	CH 41
49	CH 42
4A	CH 43
4B	CH 44
4C	CH 45
4D	CH 46
4E	CH 47
4F	CH 48

## Archiving the Console Settings

The console settings can be saved to an external device such as a MIDI sequencer or data archiver using the dump out facility. Saved settings can be loaded back into the console using dump in. This is ideal when you want to archive the settings to use at a later date, for example a re-run of a previous performance. You can also use the dump facility to program additional **ML4000** consoles, for example when setting up duplicate shows or swapping consoles around. Simply link MIDI OUT from one to MIDI IN of the other and action the dump out facility.

### Settings which are archived :

- ✓ Current mute settings
- ✓ Current Mute group assignments
- ✓ Current VCA group assignments
- ✓ Automation safes
- ✓ All snapshot memories

### Settings which are not archived :

- ✗ Current console operating mode
- ✗ Current PAFL selection and settings

## MIDI Dump Out

Connect the console to a suitable MIDI archiving device. Set the same MIDI channel number on both. Check the rear switch is set to MIDI. Press the DUMP key. The console dumps the current settings and memory contents using a SysEx message string. During this time the DUMP and MIDI LEDs light to show that data is being sent via the MIDI port. Note that this operation can take up to 10 seconds during which time the console mutes, assignment and P/AFL operations are interrupted.

## MIDI Dump In

Connect the console to the MIDI archiving device. Set the same MIDI channel number on both. Check the rear switch is set to MIDI. Start the process using the MIDI archiver. The console current settings and memory contents are overwritten. During this time the DUMP and MIDI LEDs light to show that data is being received by the console. Note that this operation can take a while during which time the console mute, assignment and PAFL operations are interrupted.

If you are using a MIDI sequencer to record the dump out data string then make sure you play it back at the same speed you recorded it. If you dump it back into the console faster than it was recorded some data may not load correctly.

## MIDI Dump Message Format

The format for dump out and in is identical. The dump data string is made up of multiple System Exclusive messages (known as packets) which contain the console information.

**Transmit and Receive.** The format for a single packet is as follows:

F0 <SysEx header> <packet type> <packet number> <data> <checksum> F7

<SysEx header> = 00 00 1A 50 07 VV vv nn

Where VV = software version number – unit  
vv = software version number – decimal  
nn = console MIDI channel number

<packet no.> = packet number from 0 to 127

<data> = block of console data (7-bit format)

<checksum> = checksum to allow error detection

## MIDI Dump Errors

If the console or connected equipment fails to respond to a MIDI dump then check:

The MIDI cable is good and correctly plugged

The same MIDI channel number is selected

The rear panel switch is set to MIDI

Try again

## Allen & Heath ML4 Archiver

The ML4Archiver Windows™ utility for the PC can be downloaded from the Allen & Heath Internet site. This can be used to archive data to and from the PC via MIDI or RS232.

The program also includes the useful Snapshot Manager which lets you store and recall the console mute settings and VCA group assignments from the 128 internal snapshot memories. The snapshots cannot be accessed from the console control panel itself. The archiver provides this extra feature.

Check the Allen & Heath Web site for further details and loading instructions.

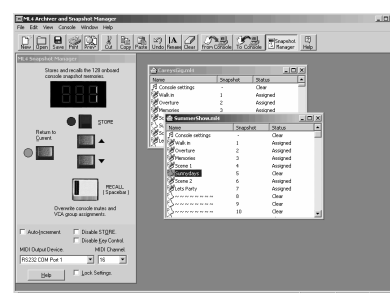

# Console Computer and Operating Software

---

## Operating Software Version Number

You can check the current version number of the **ML4000** software running on the console using a PC connected via RS232. Instructions for this are provided on the Allen & Heath Internet site.

## Loading New Operating Software

Check the Allen & Heath Web site for the latest version of console software. New software is loaded from a PC via the RS232 port.

**IMPORTANT ! The current console settings and snapshots may be lost when you load new operating software.** If you wish to keep your settings and snapshot contents, first archive them using the dump out facility. Restore these after loading the new software by using dump in.

Download the software from the Allen & Heath Web site to your PC computer. Connect the PC RS232 port to the console RS232 port using a standard pin-to-pin (not null modem) 9-pin serial cable. Set the console rear panel switch to the RS232 position. Power up the console. The console awaits data from the PC. Follow the instructions provided on the Web site for loading the new software into the console. When completed make sure you set the console rear panel switch back to its normal operating position, typically MIDI.

## Power Up and Power Down

The console settings are saved when power is removed. On power up these settings are restored.

## To Reset the Console Settings

Hold down the MIDI CH and EDIT SAFES keys together while turning on the console to reset all current settings. This does not affect the contents of the snapshot memories. The default settings are restored:

- Selects normal console operating mode
- Clears all current Mute Group assignments
- Clears all current VCA Group assignments
- Clears all channel automation safes

## To Reset the Snapshot Memories

Hold down the MIDI CH and DUMP keys together while turning the console on to clear all the snapshot memories. This does not affect the current console settings. For all snapshots reset:

- Clears all stored mutes
- Clears all stored VCA Group assignments

## To reset all Settings and Memories

Hold down the MIDI CH, the EDIT SAFES and DUMP keys together while turning the console on to clear all current settings and the memories.



### Important Note:

1. If a sidecar expander is used with the **ML4000** make sure it is running the same version of software as the master console.
2. If it is necessary to replace the CPU assembly make sure the jumper links are correctly set on the replacement assembly. These are set differently for the master and sidecar consoles. Refer to drawing D44 for details.
3. If it is necessary to replace the MIDI/PSU assembly make sure the jumper links are correctly set on the replacement assembly. These are set differently for the master and sidecar consoles. Refer to drawing D42 for details.

## Internal Options Links

---

The **ML4000** is designed to offer the utmost flexibility to satisfy the application without modification. However, the following internal link options are provided to allow customisation to satisfy the more specialist applications or personal preferences. Remember to set these internal links according to the user requirement if replacing assemblies while carrying out service work:

**Mono channel AUX options** The pre-fade sends are set pre-insert, pre-EQ, post-mute as standard. Jumper links on the mono circuit cards can be replugged to configure post-insert, pre-EQ and/or pre-mute. Refer to drawing D1 and D3.

**Stereo channel AUX options** The pre-fade sends are set pre-EQ, post-mute as standard. Jumper links on the stereo circuit cards can be replugged to configure post-EQ and/or pre-mute. Refer to drawing D5 and D7.

**Mono channel DIRECT outputs** These are derived post channel fader as standard. A jumper link on each card can be replugged to configure pre-fader or post-fade with level trim. The direct out pre-fade source is the same as that configured to feed the aux sends. The level trim option disables the channel Aux1 send and uses its send as the direct out level control. Two links need to be set in this case, one to send the direct output signal through the send control, the other to disable the Aux1 send from the channel. Refer to drawing D1.

**2-track output source** These are set post master insert and fader as standard. Two pairs of jumper links can be replugged to derive the output pre-insert, pre-fader. Refer to drawing D18 and D20.

## Internal Assembly Assignments

---

The following assignment links need to be set according to assembly position in the console. These should not need changing unless a replacement assembly has been fitted.

**Group 1,3,5,7 buss assignment** Zero ohm links determine which busses feed the group and aux mix amps. Refer to drawing D11 and D12.

**Group 2,4,6,8 buss assignment** Zero ohm links determine which busses feed the group and aux mix amps. Refer to drawing D14 and D15.

**VU meters 1-8** The same assembly type is used for meters 1-4 and 5-8. The position in the console is determined by soldered links. Refer to drawings D38, D39 and D40.

**MIDI/PSU assignment** Position two pairs of links according to whether the assembly is fitted to a console or a sidecar. Refer to drawing D42.

**CPU assignment** Position the three links according to the console type as shown on drawing D44

## The Range

---

ML4000-24	24 mono, 2 dual stereo input - Live sound console
ML4000-32	32 mono, 2 dual stereo input - Live sound console
ML4000-40	40 mono, 2 dual stereo input - Live sound console
ML4000-48	48 mono, 2 dual stereo input - Live sound console
ML4000-24SC	24 mono input - Expander sidecar
MPS14	2U power supply unit - For ML5000 console
002-583	2.8 metre DC power lead – To connect MPS14 power supply to console
002-584	0.5 metre DC combiner lead - To link two MPS14 power supplies
002-617	2.8 metre 37way Audio cable - To link sidecar to console
AL4155	2.8 meter 9way Logic cable - To link sidecar to console
AP4314	ML4000 Console User Guide
AP4373	ML4000 Sidecar User Guide
AP4316	ML4000 Console Service Manual
AP3898	MPS14 Power Supply User Guide
AP4143	MPS14 Power Supply Service Manual
AL4061	Gooseneck lamp 18"

## Ordering Spares

---

Spare parts and replacement assemblies can be ordered from Allen & Heath. When doing this please provide full details including console size and model, serial number and description of the part.

If you are ordering replacement assemblies please quote the channel position in the console. Several assemblies need to be link assigned according to position. Failure to observe the correct link setting may result in incorrect console operation. Details of these link assignments are printed on the relevant circuit diagrams later in this manual.

If you have any queries about the automation system please quote the console operating system version number.

Technical support is available through the Allen & Heath distribution network or direct from Allen & Heath. Many resources are available from the Allen & Heath Internet Web site:

[www.allen-heath.com](http://www.allen-heath.com)  
[spares@allen-heath.com](mailto:spares@allen-heath.com)

## **ORDERING AN ML4000 SPARES KIT**

It is recommended that the spares kit order code **002-699** is held and maintained by the service agent to enable in-field service repairs to the **ML4000** independent of the ALLEN & HEATH factory. Commonly available items such as resistors, capacitors, tools and soldering equipment are not included. The contents of the kit are listed below and are supplied in a cabinet of drawers. Individual spare parts may be ordered. Please quote the description and order code for the part required.

### **Fixings:**

<b>DESCRIPTION</b>	<b>ORDER CODE</b>	<b>QTY</b>
Screw 4AB x 5/16" CSK Pozi Black	AB0059	10
Screw M3 x 6 Pan Torx Black	AB0072	5
Screw M3 x 8 Pan Torx Black	AB0073	10
Screw M3 x 8 CSK Torx Black	AB0074	10
Nylock Nut M3	AB0102	20
Nylock Nut M4	AB0105	10
Screw M3 x 4 Pan Torx Black	AB0233	10
Screw 4AB x 1/2" Pan Torx Black	AB0250	10
Screw M6 x 20 CSK Torx Black	AB0310	5
Screw 6B x 3/8 CSK Pozi Zinc	AB2082	20
Screw 6B x 1/4" CSK Pozi Zinc	AB2083	10
Screw 8B x 3/8 CSK Pozi Black	AB2085	10
Screw M4 x 12 CSK Torx Black	AB2086	5
Screw 3.5 x 25 Chipboard Pan Pozi	AB2647	5
Screw M4 x 8 CSK Torx Black	AB2777	5
Screw 6B x 5/16 Pan Torx Black	AB2809	20
Screw M3 x 4 CSK Torx Black	AB2811	20
Screw M2 x 4 CSK Pozi Black	AB3329	10
Screw M3 x 4 TT Hex Head Black	AB3837	20
Screw M6 x 12 CSK Torx Zinc	AB4036	5
Screw 6B x 3/8 Flange Headed Pozi Black	AB4037	10
Washer M4 Finishing	AB4376	5
Spacer LED 10.7mm	AB4383	1
Pot Nut 9mm	AB8050	50

### **Knobs and caps:**

<b>DESCRIPTION</b>	<b>ORDER CODE</b>	<b>QTY</b>
Knob Red & Grey 11mm	AJ2074	10
Knob Blue & Grey 11mm	AJ2075	30
Knob Light Blue & Grey 11mm	AJ2076	30
Knob Green & Grey 11mm	AJ2077	15
Knob Dark Grey & Grey 11mm	AJ2078	15
Knob Yellow & Grey 11mm	AJ2079	10

Knob Brown & Grey 11mm	AJ2080	10
Button 10x5mm Rectangular Grey	AJ2865	2
Button 10x5mm Rectangular Black	AJ3228	1
Button 5mm Square Red	AJ3488	15
Fader Knob 11mm Black + White Line	AJ3503	15
Switch Cap Light Blue/Grey Offset	AJ3863	20
Button Illuminated Red	AJ3949	2
Switch Cap Light Blue/White Offset	AJ3950	15
Button 6x6mm Square White	AJ3951	10
Button 6x6mm Square Light Grey	AJ3952	5
Button 6x6mm Square Red	AJ3953	2
Button 6x6mm Square Black	AJ3954	5
Button 8mm Round Light Grey	AJ3955	10
Fader Knob 11mm White+Black Line	AJ8078	5
Fader Knob 11mm Red+Black Line	AJ8079	10
Fader Knob 11mm Blue+Black Line	AJ8081	10
Button Illuminated White	AJ8107	10

### **Faders, Potentiometers, Switches and connectors:**

Pot 10KC x 2 (103C 14mm wide)	AI0150	2
Fader 10KA Dust 60mm	AI3497	5
Pot 20KK (203K 11mm wide)	AI8003	10
Pot 20KB C/D (203B 11mm wide)	AI8004	10
Pot 200KC x 2 (204C 11mm wide)	AI8005	5
Pot 20KB x 2 centre click (14mm wide)	AI8006	3
Pot 20KK x 2 (203K 14mm wide)	AI8007	1
Pot 10K (103AC 14mm wide)	AI8008	5
Pot 200KC x 2 (204C 14mm wide)	AI8009	5
Fader 10KSPE 100mm	AI8109	3
Pot 5K (502RD 11mm wide)	AI8111	5
Fader 10KB 100mm	AI8175	10
Switch 2PCO Latching	AL0162	15
Jack Socket Headphone	AL0328	1
Switch 4PCO Latching	AL0333	10
Switch 2PCO Momentary	AL0374	10
XLR 3 Pin Female Vertical PCB Mount	AL2410	5
XLR 3 Pin Male Vertical PCB Mount	AL2411	5
Switch Slide MINI SPDT PCB	AL3081	1
Jack Socket ¼" Stereo Unswitched	AL3407	15
Jack Socket ¼" Stereo Switched	AL3410	20
Switch 2PCO Latching 90 Deg	AL8065	10

**LEDs and Semiconductors:**

Transistor BC549 NPN	AE0020	10
IC TLO72 Op-Amp	AE0046	10
Transistor J111N FET T092B	AE0083	10
LED 3mm T1 Yellow	AE0084	10
LED 3mm T1 Green	AE0085	10
LED 3mm T1 Red	AE0086	10
IC CMOS 4053B	AE0117	10
IC CMOS 4051B	AE0118	1
IC NE5532N Op-Amp	AE0221	10
IC 6N136 Opto-Isolator	AE0222	1
IC TTL 74LS00	AE0243	1
IC Opto-Isolator 4N35V	AE0266	2
IC 7805 Regulator	AE0308	3
IC RS232 HIN202CP	AE2742	1
IC CMOS 74HC165	AE2749	3
IC CMOS 74HC4094N	AE2755	5
IC Comparator LM393N	AE2818	5
Transistor BC556B PNP	AE3001	5
Crystal 14MHz	AE3007	1
LED Square Red	AE3489	3
Transistor Mosfet BSS138	AE3498	1
IC CMOS 74HCT02	AE3988	1
IC SN75176BP	AE3989	1
LED Rect. Red 5 x 2.5mm Flat Top	AE4015	3
LED Rect. Yellow 5 x 2.5mm Flat Top	AE4016	3
LED Rect. Green 5 x 2.5mm Flat Top	AE4017	3
IC THAT2155 VCA	AE4279	5
Transistor 2SB737 PNP	AE8069	10

**Miscellaneous:**

Preset 10K Carbon Vertical Mini	AC0250	5
Preset 22K Carbon Horizontal Adjust	AC3980	5
Meter bulb 8V	AD0013	5
VU Meter + 8V Bulb	AD3321	2
Flex Cable 12 Way 90mm	AH2228	2
Flex Cable 15 Way 90mm	AH4091	3
Battery 2.4V 70mAh NI-MH	AP3334	1



## ORDERING AN MPS14 SPARES KIT

It is recommended that the spares kit order code **002-632** is held and maintained by the service agent to enable in-field service repairs to the **MPS14** independent of the ALLEN & HEATH factory. Commonly available items such as resistors, capacitors, tools and soldering equipment are not included. The contents of the kit are listed below and are supplied in a cabinet of drawers. Individual spare parts may be ordered. Please quote the description and order code for the part required.

### Power supply:

DESCRIPTION	ORDER CODE	QTY
Insulating Kit TO220	AA3514	5
Insulating Pad TDA7294 IC	AA3645	4
Screw M3x 6mm Pan Torx Black	AB0072	10
Screw M3 x 8mm Pan Torx Black	AB0073	3
Screw M3 x 10 Pan Torx Black	AB0076	10
Nylock Nut M3	AB0102	5
Pillar M4 x 10 Nylon Tap	AB0257	3
Screw M4 x 5 Pan Slotted Zinc	AB0261	10
Screw M4 x 8 Countersunk Torx Black	AB2777	5
Screw 6B x 5/16 Pan Torx Black	AB2809	10
Screw 4 x 5/16 Poly Pan Torx Black	AB2810	10
Clip TO220 Type 4426	AB3547	3
Clip TO247 Type 4597	AB4148	3
Res W/Wound 0R33 2.5W 5%	AC3014	3
Preset 1K Carbon Vertical Adjust	AC3958	1
Res Planar 10R 10W	AC4002	2
Zener Diode BZX85 5V6 1.3W	AE0012	3
IC TL072 Dual Op-Amp	AE0046	3
IC 7815 Regulator	AE0047	2
Transistor BC637 NPN TO92H	AE0068	2
IC LM339N Comparator	AE0071	3
IC Regulator 783	AE0214	2
IC Op-Amp NE5532N	AE0221	3
Zener Diode BZX55C2V7 400mW	AE0231	2
Zener Diode BZX79C 12V 250mW	AE0232	2
IC Regulator 7818	AE3155	2
Diode BYW81P-200 15A	AE3468	2
Diode BYV27-400 2A	AE3469	3
Diode BYV26E 1A 1000V	AE3470	3
Diode P6KE200A	AE3471	3
Transistor Mosfet STP4NB80FP	AE3472	3
IC SMPS UC3842AN	AE3473	2
Bridge Rectifier 2KBP06M	AE3477	2

Thermistor 100K	AE3499	2
LED Rect. Green 5 x 2mm Flat Top	AE3501	2
LED Rect. Red 5 x 2mm Flat Top	AE3502	3
IC Regulator 7812	AE3588	2
Zener Diode BZV85 20V 1.3W	AE3815	2
Diode 1N5819 1A 40V	AE3914	3
Bridge Rectifier RBV2506	AE3921	2
Transistor Mosfet IRF540N	AE3924	2
Transistor Mosfet IRF9540N	AE3925	2
Transistor Mosfet IRFP450A	AE3926	3
Diode RURP3060 30A 600V	AE3933	3
Diode SQ045 8A 45PIV	AE3934	3
Diode FE6D 6A 35NSEC	AE3935	3
IC SG3525AN PWM Control	AE3938	3
IC UC3854AN PFC Control	AE3939	3
Transistor Mosfet ZVN2106A	AE3940	2
Transistor Mosfet ZVP2106A	AE3941	2
Transistor MPSA92 PNP	AE8119	1
Transistor MPSA42 NPN	AE8138	1
Inrush Supressor	AE8143	1
Fastfoot	AK0102	4
Foam Filter 80 x 80mm	AK4070	3
Fuse 6.3A Anti-Surge 20mm	AL0395	5
Fuse 1.6A Anti-Surge 20mm	AL0466	5
Fuse 5A Anti-Surge 20mm	AL2270	5
Fuse Holder 10A 20mm PCB	AL3447	1
Fuse 500mA Anti-Surge 20mm	AL3534	5
Switch 2PCO Latching Vertical	AL8057	1
Inductor 4.7uH 600mA	AM3467	5
Inductor Ferrite Sleeve	AM3657	3
Inductor 5MH 5A CMC	AM3900	1
Inductor 330UH 1A	AM3901	1
Inductor 150UH	AM3902	1
Inductor 10UH	AM3903	1
Inductor 1MH	AM3904	1
Transformer HF Pulse PCB	AM4006	1
Fan 80x80x25.5 12V	AM4474	1

## Technical Drawings

The following section includes the full set of technical drawings associated with the **ML4000**.

The **BLOCK DIAGRAM** is the same as printed in the User Guide and illustrates the signal flow through the console.

The **MAP DRAWINGS** show the interconnection between the various circuit assemblies. These are marked with letter references to help you find the associated connectors on the circuit diagrams.

The **PCB** and **CIRCUIT** drawings show the details for each assembly. Option and assignment links are marked where appropriate. The drawings included are listed in the contents at the start of this manual.

If you have any queries or require further information please contact Allen & Heath.

h  
g  
f  
e  
d  
c  
b  
a

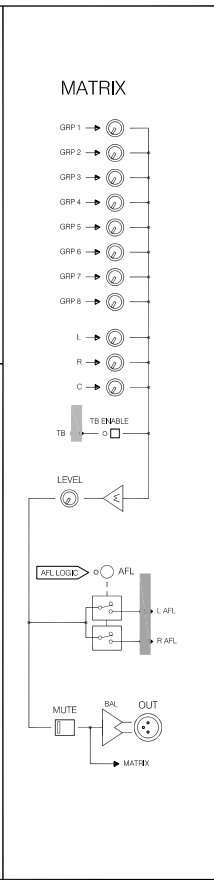
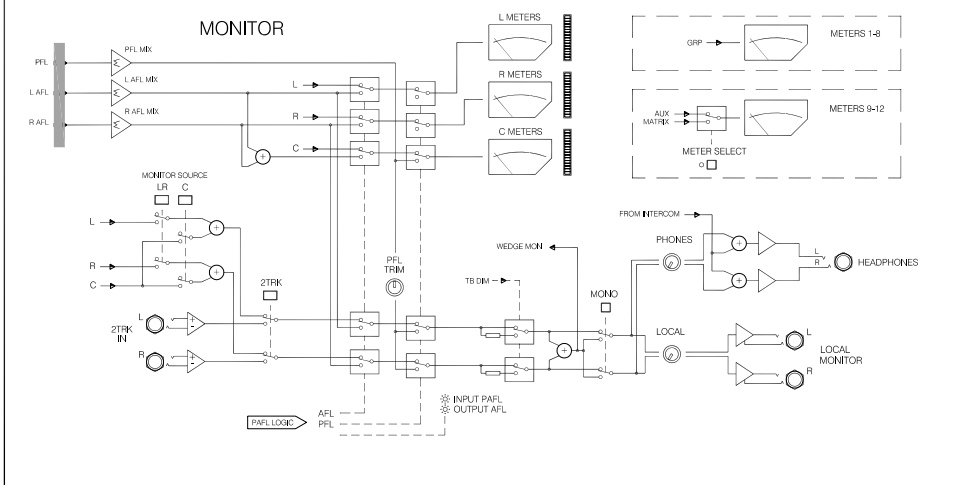
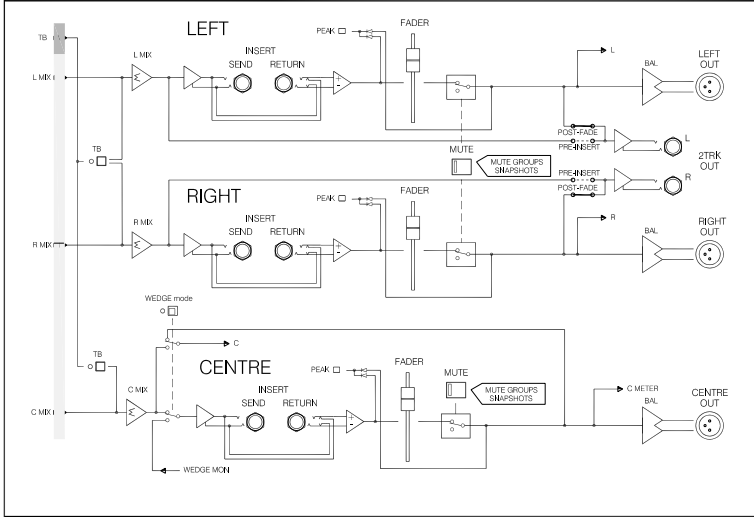
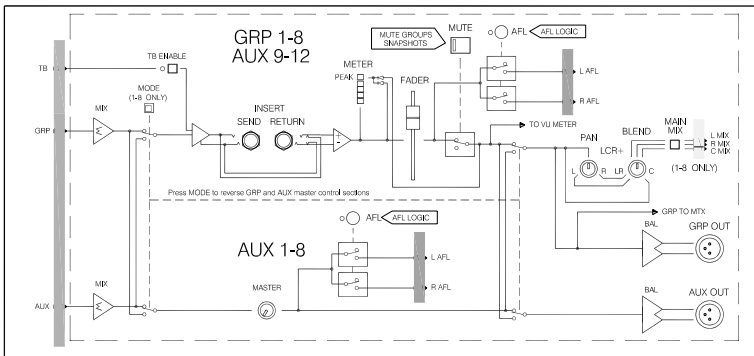
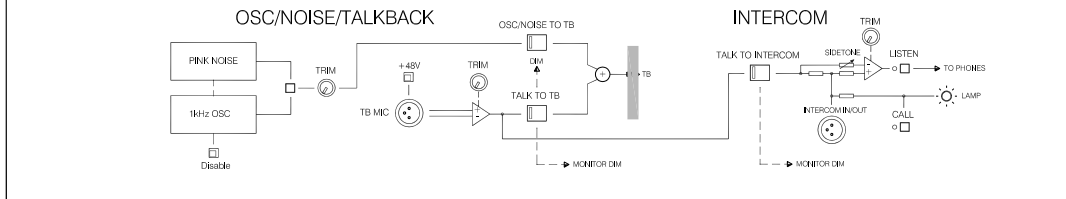
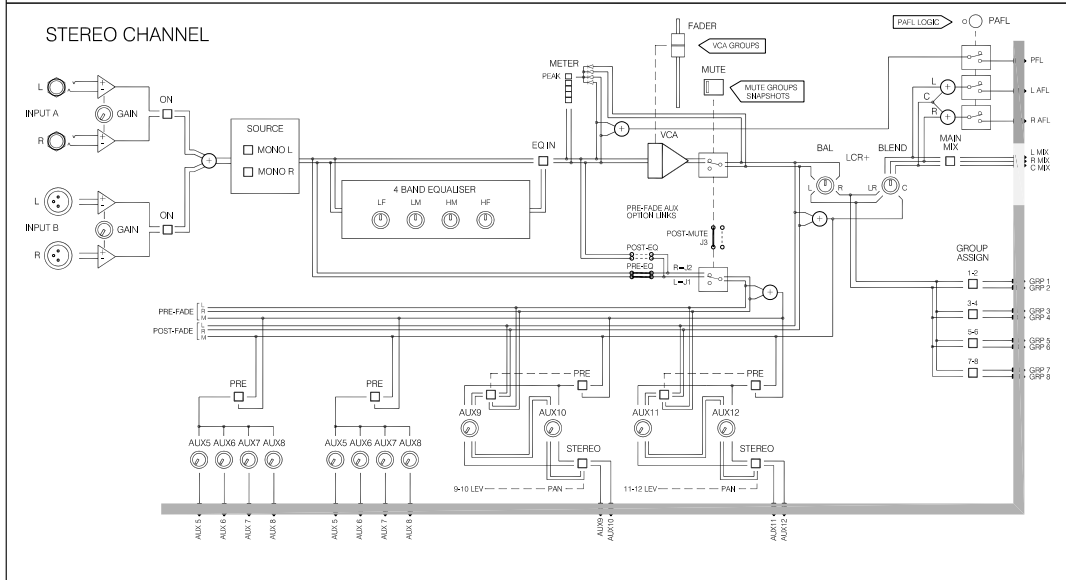
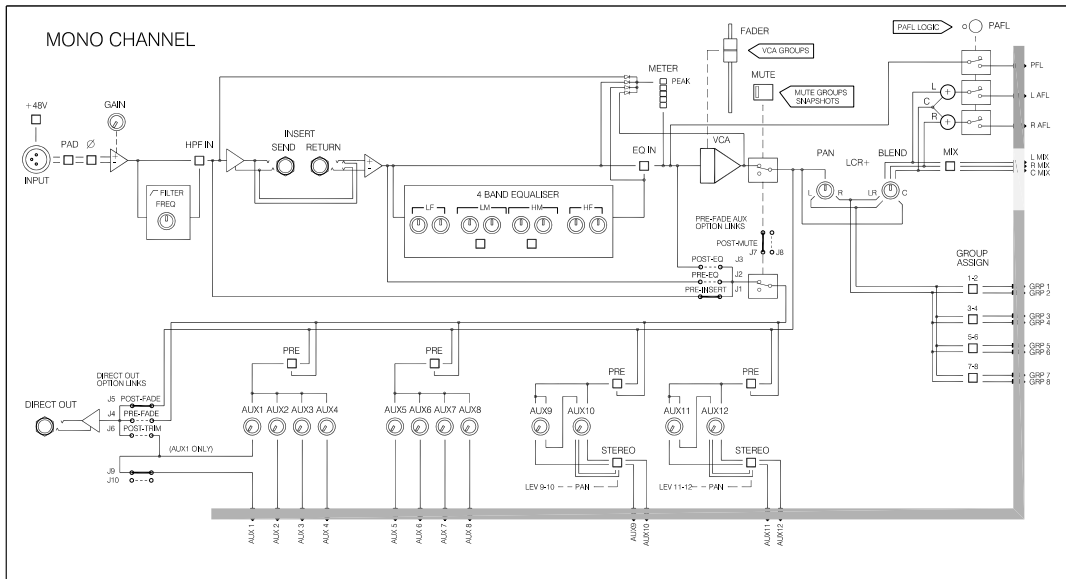

ML4000 BLOCK DIAGRAM

FROM CONNECTORS

INTERNAL VIEW WITH BASE REMOVED

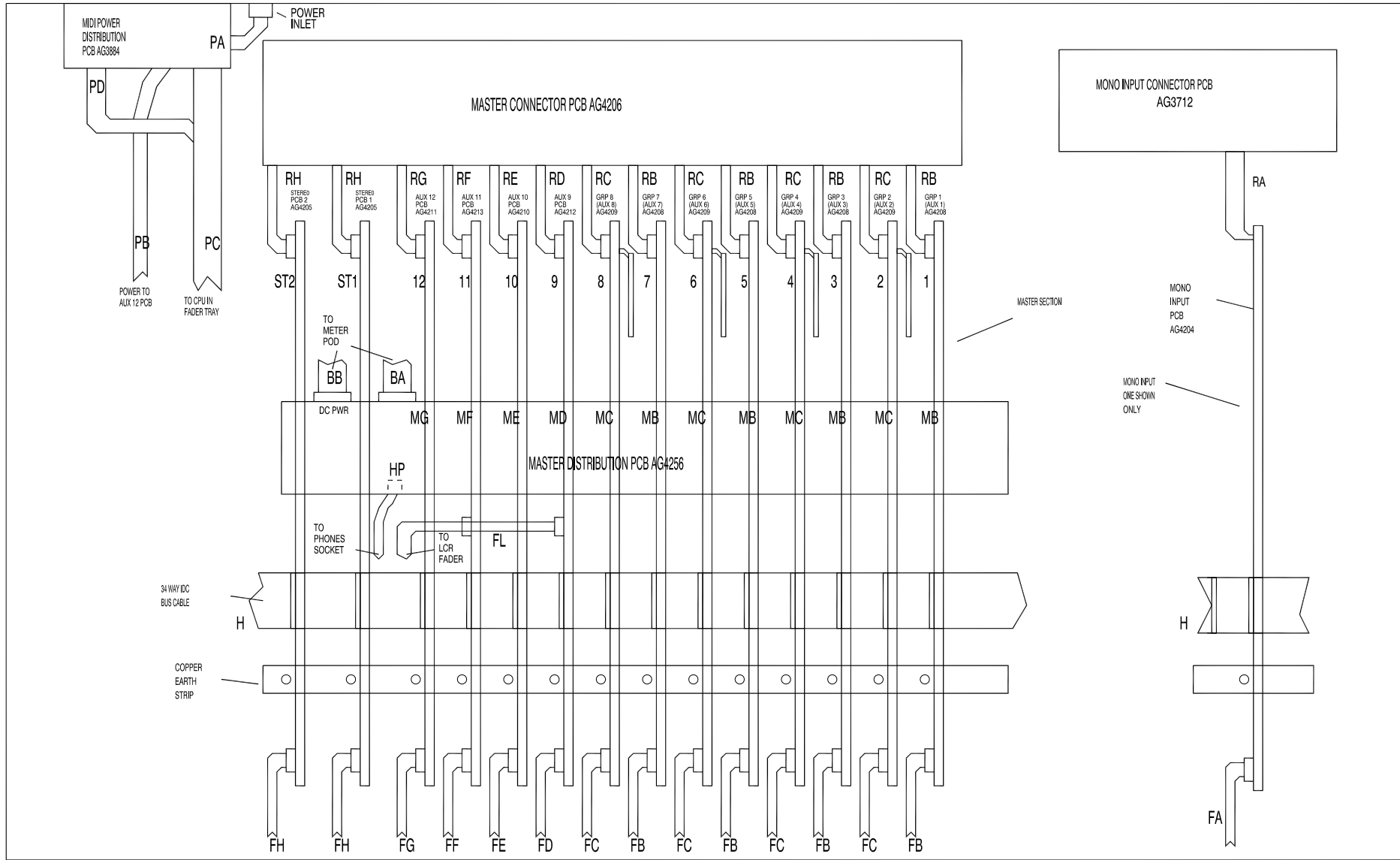

TO FADER BAY

ML4000 INTERNAL ASSEMBLIES AND CONNECTIONS SHEET 1 of 2

A

B

C

D

E

F

h  
g  
f  
e  
d  
c  
b  
a

METERPOD PCB VIEW FROM REAR

WARNING: Do not reverse these two connectors!

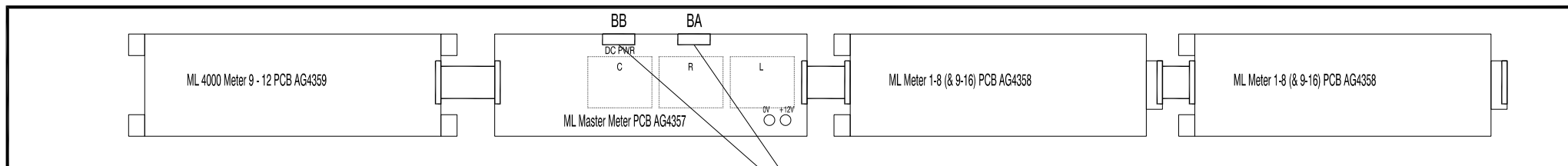

FADER MODULE UNDERSIDE VIEW

CF = 33-40  
CG = 41-48

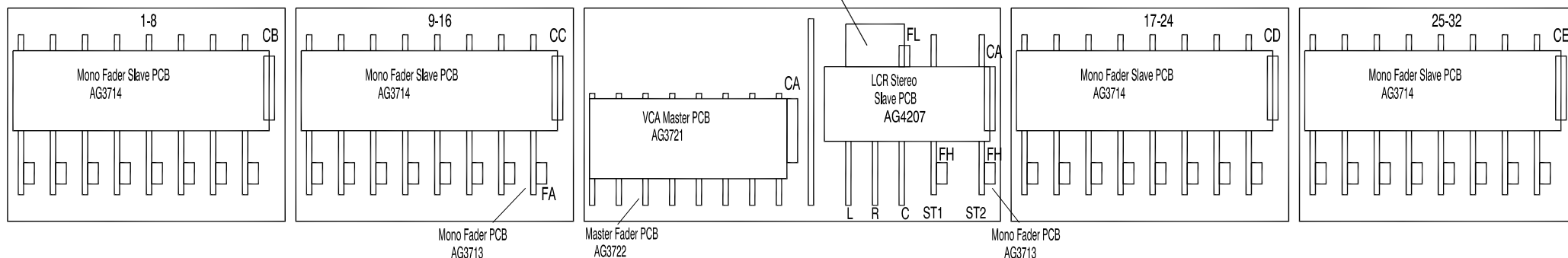

FADER TRAY TOP VIEW

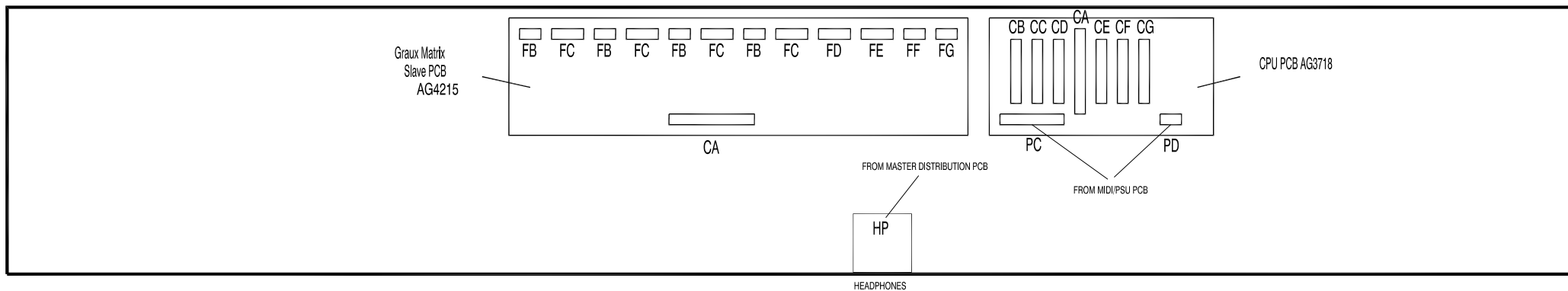

ML4000 INTERNAL ASSEMBLIES AND CONNECTIONS SHEET 2 of 2

MONO INPUT PCB AG4204 issue 2

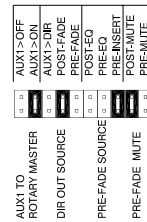
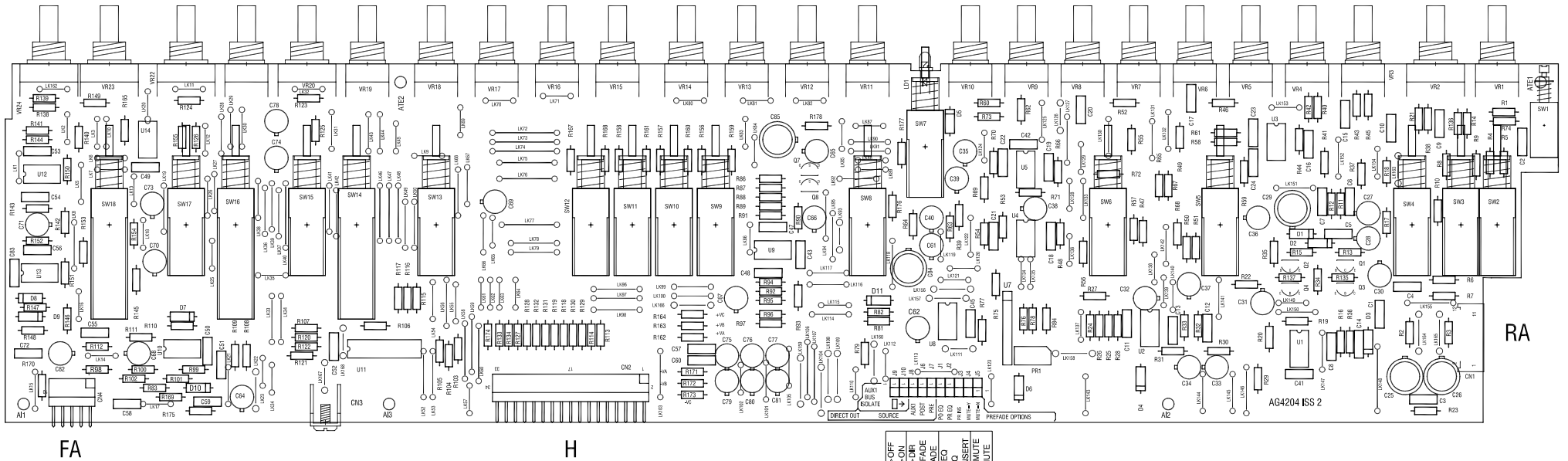

OPTION LINKS

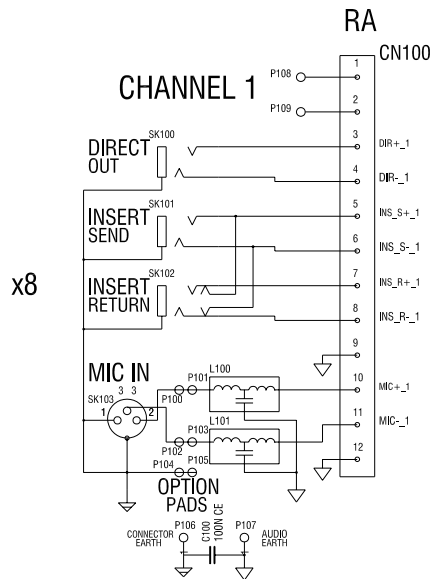

From DRAWING No. C3712 ISSUE 3

RA

MONO CONNECTOR PCB AG3712 issue 3

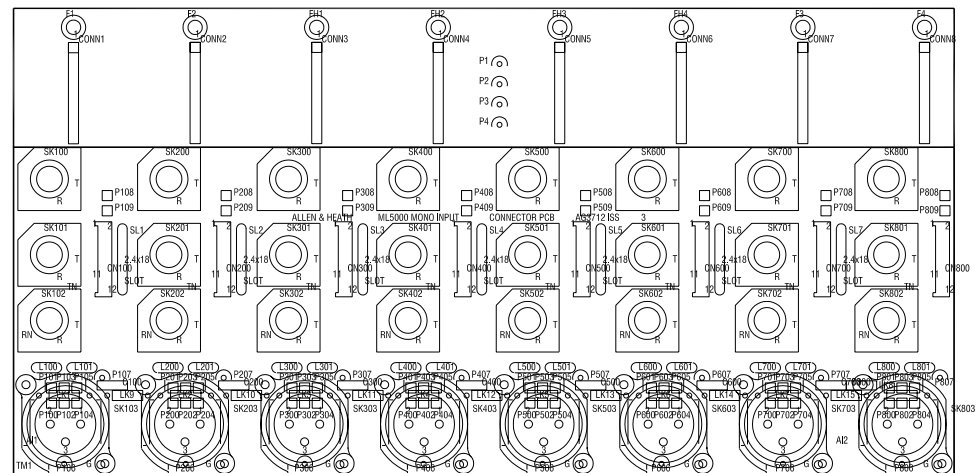

h  
g  
f  
e  
d  
c  
b  
a

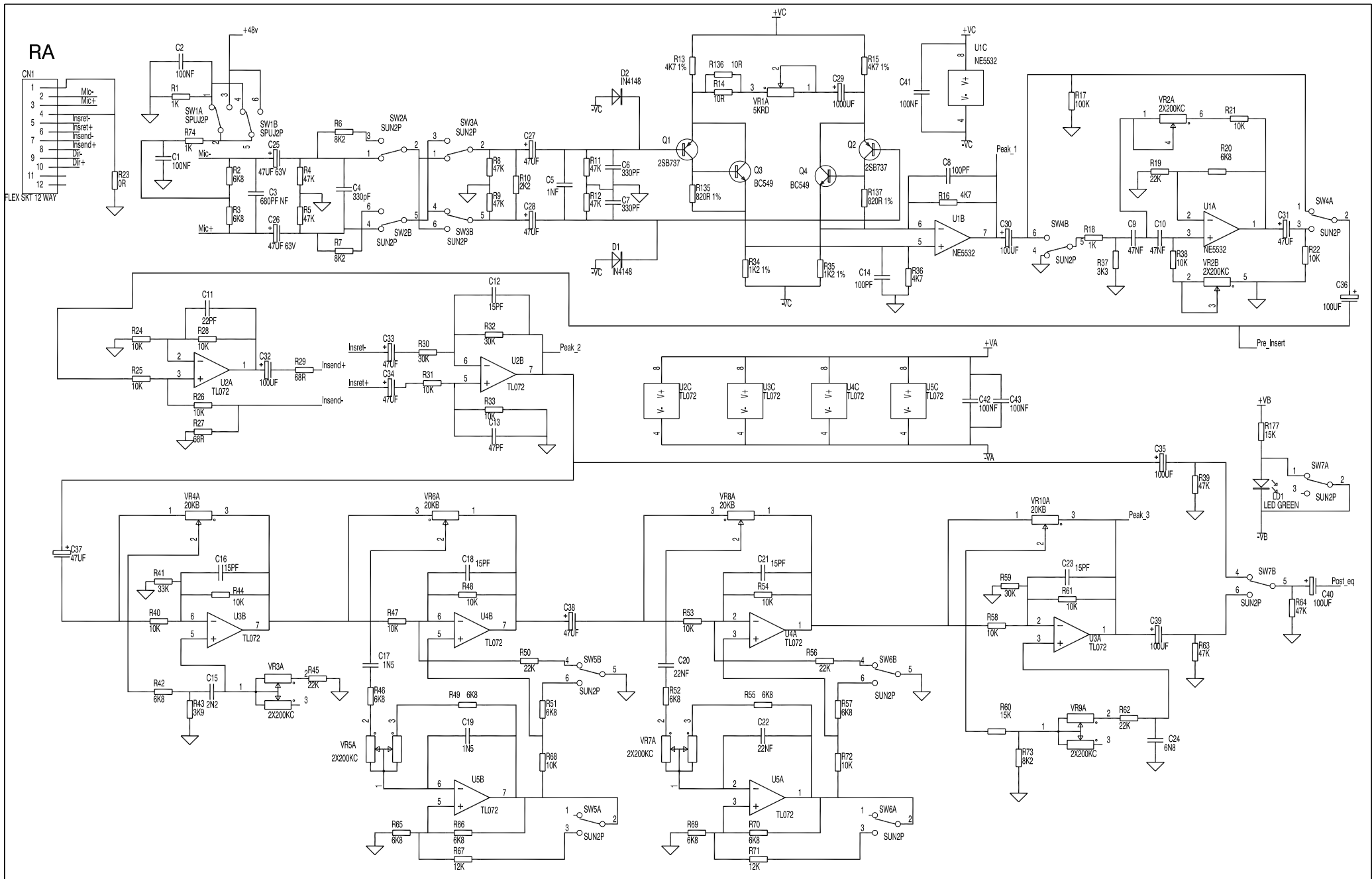

ML4000 MONO INPUT CIRCUIT C4204 issue 2 SHEET 1 of 3

ISSUE	BY	DATE
A1	MG	21-6-00

**ALLEN&HEATH**  
 Kennick Industrial Estate,  
 Penryn, Cornwall,  
 England, TR10 9LU  
 Tel: (44) (0) 1326 372070 Fax: (44) (0) 1326 365736



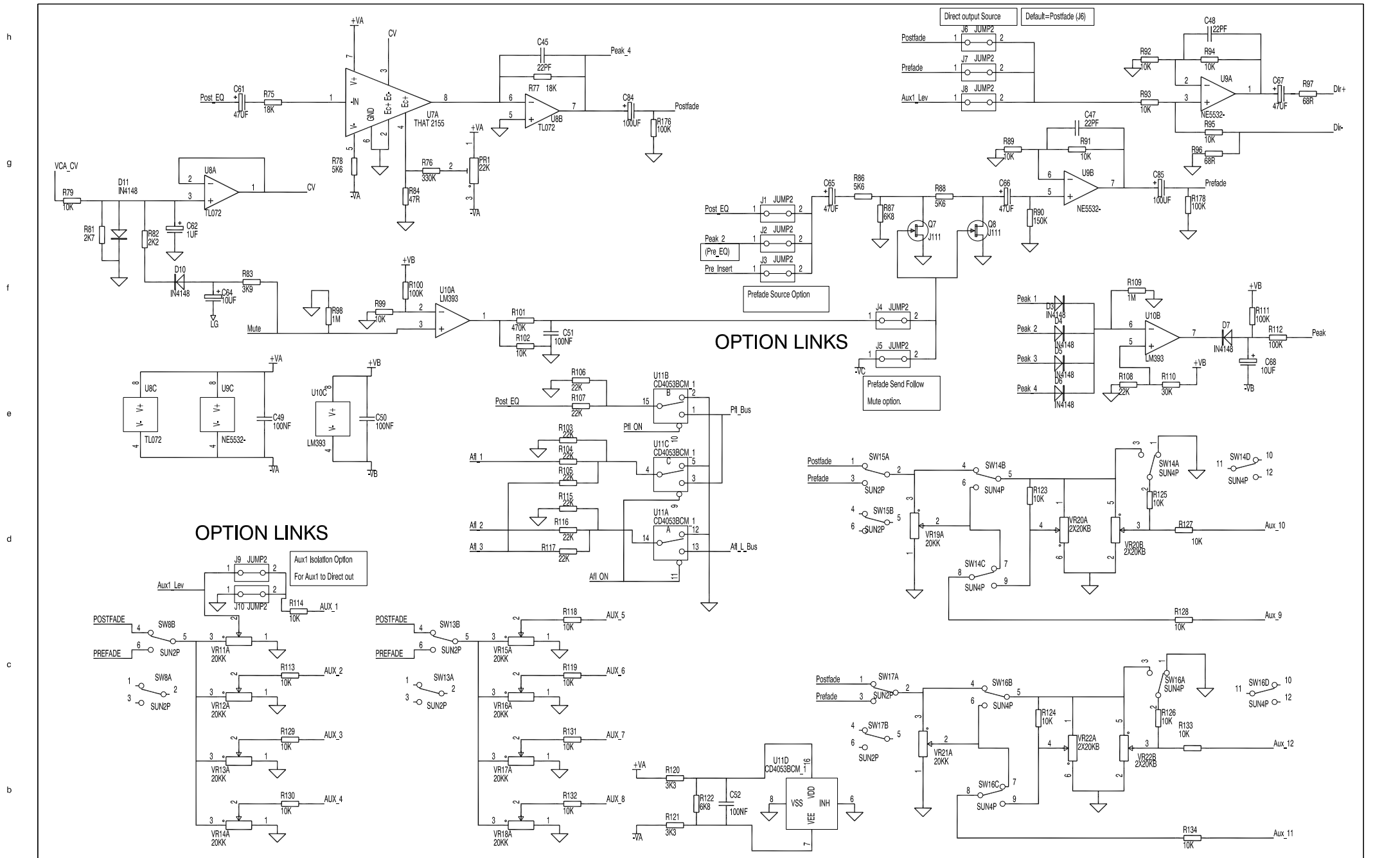

ISSUE	BY	DATE
A1	MG	21-6-00

ML4000 MONO INPUT CIRCUIT C4204 issue 2 SHEET 2 of 3

**ALLEN&HEATH**  
 Kernick Industrial Estate,  
 Penryn, Cornwall,  
 England, TR10 9LU  
 Tel: (44) (0) 1326 372070 Fax: (44) (0) 1326 365736

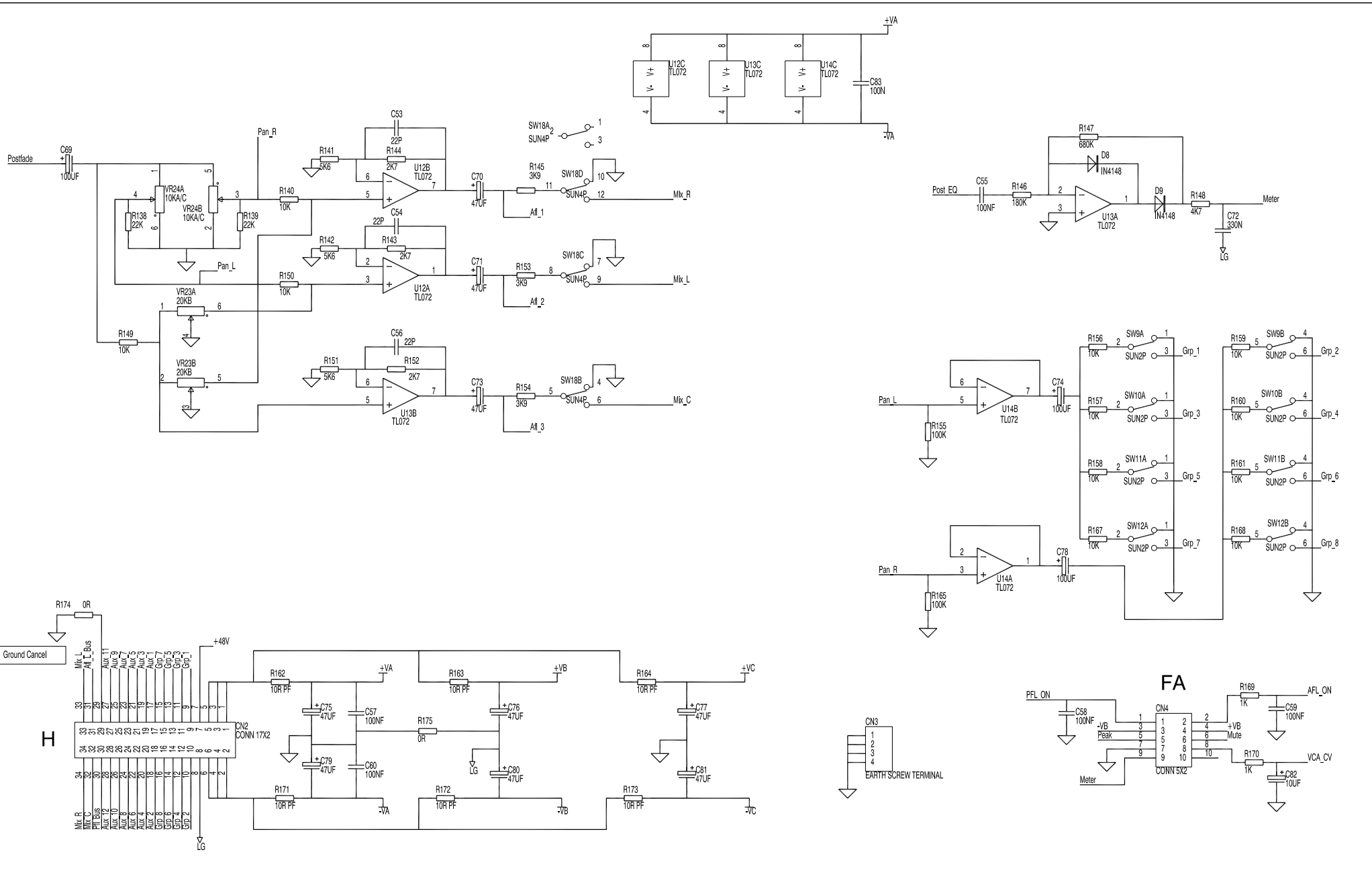

ISSUE	BY	DATE

ML4000 MONO INPUT CIRCUIT C4204 issue 2 SHEET 3 of 3

**ALLEN&HEATH**  
 Kernick Industrial Estate,  
 Penryn, Cornwall,  
 England, TR10 9LU  
 Tel: (44) (0) 1326 372070 Fax: (44) (0) 1326 365736

STEREO INPUT PCB AG4205 issue 2

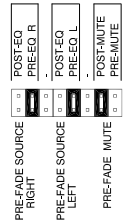
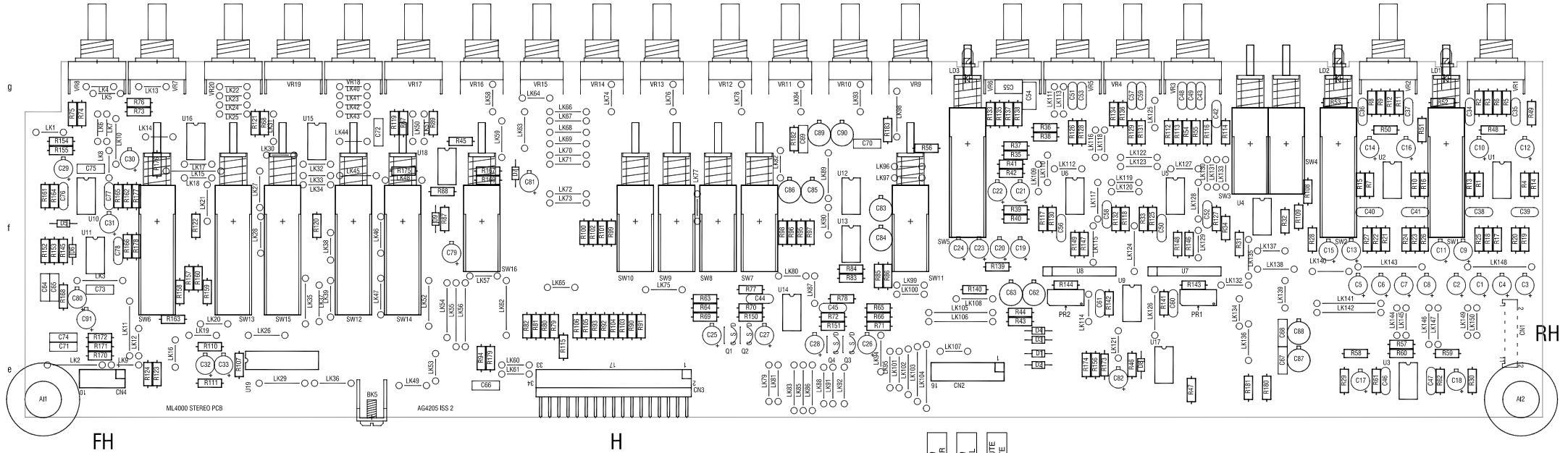

OPTION LINKS

STEREO INPUT CONNECTORS ARE ON MASTER CONNECTOR PCB AG4206

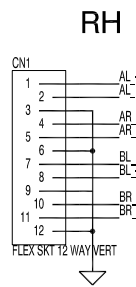
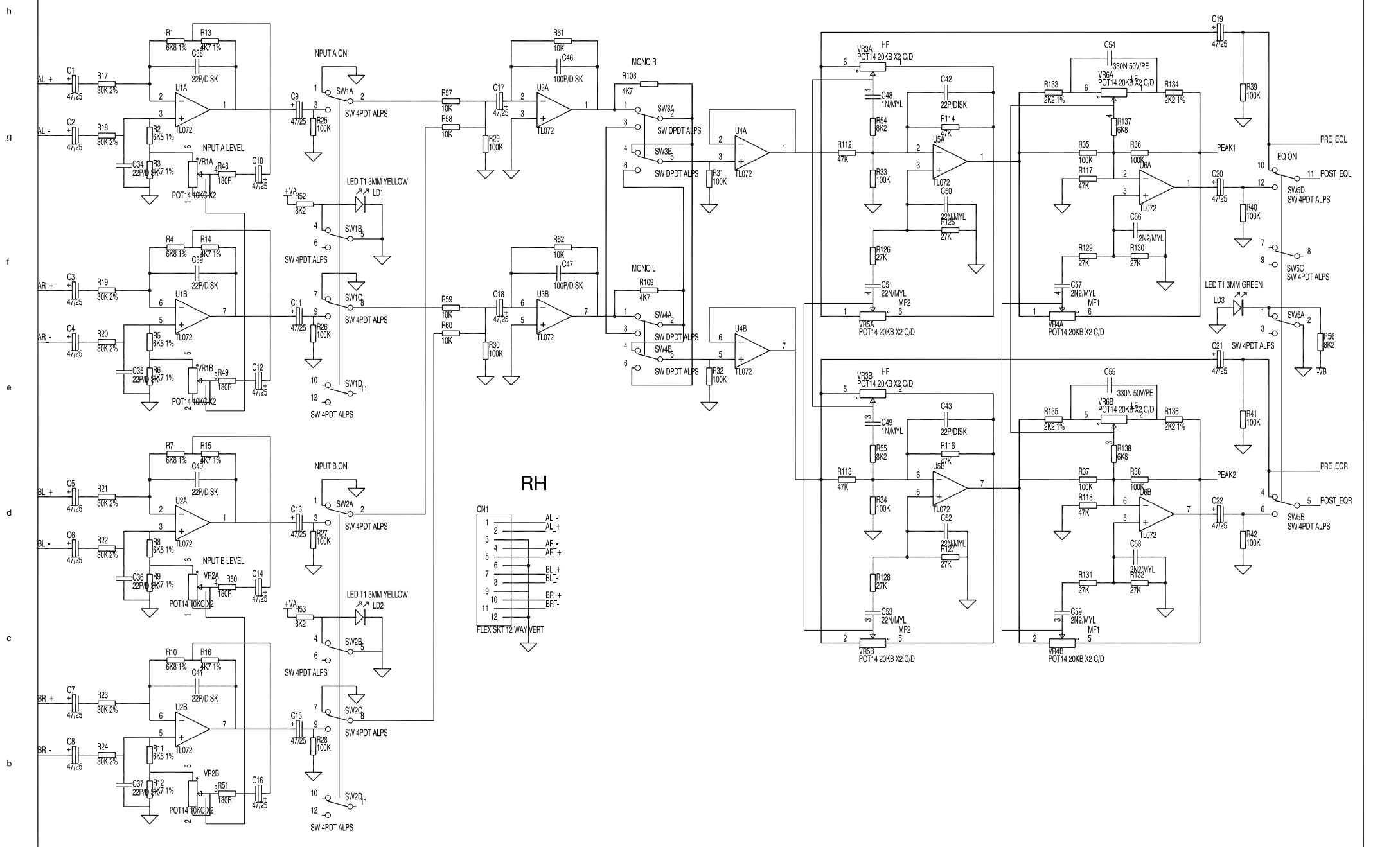

ISSUE	BY	DATE
A	AAT	21-09-90
1	AAT	21-10-90
2	AAT	11-09-91

**ML4000 STEREO INPUT CIRCUIT C4205 issue 2 SHEET 1 of 3**

**ALLEN&HEATH**  
 Kernick Industrial Estate,  
 Penryn, Cornwall,  
 England, TR10 9LU  
 Tel: (44) (0) 1326 372070 Fax: (44) (0) 1326 365736

h  
g  
f  
e  
d  
c  
b  
a

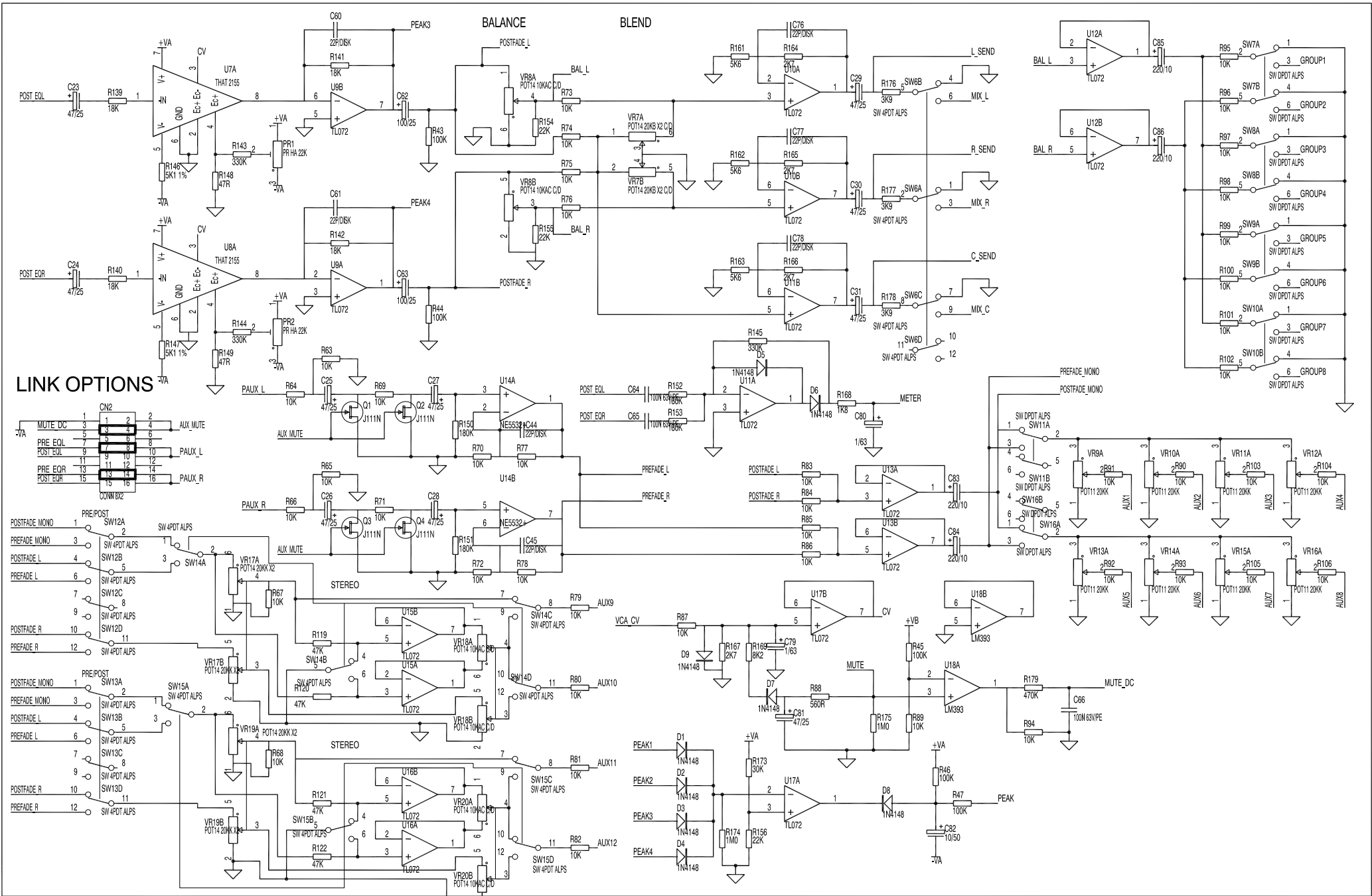

ISSUE	BY	DATE
A	AAT	25/09/00
1	AAT	25/10/00
2	AAT	11/09/01

ML4000 STEREO INPUT CIRCUIT C4205 issue 2 SHEET 2 of 3

**ALLEN&HEATH**  
 Kernick Industrial Estate,  
 Penryn, Cornwall,  
 England, TR10 9LU  
 Tel: (44) (0) 1326 372070 Fax: (44) (0) 1326 365736

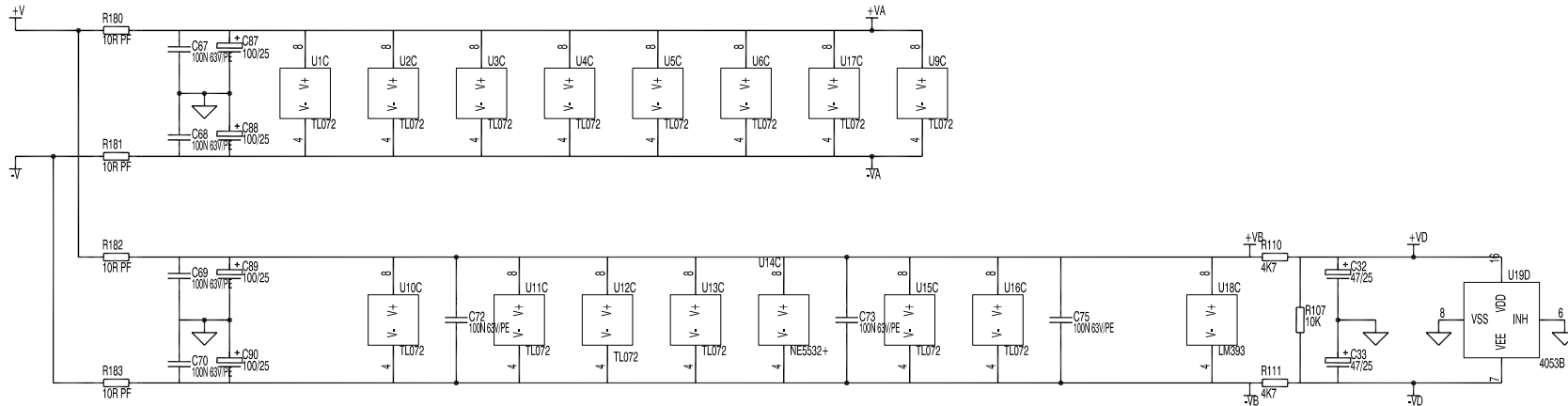

**FH**

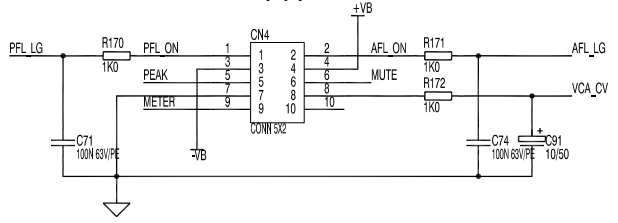

**H**

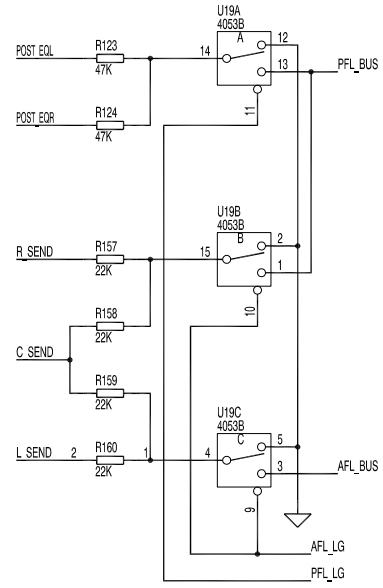
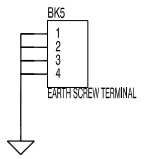
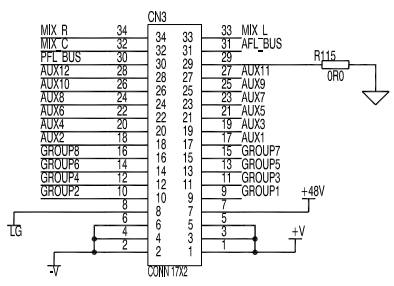

ISSUE	BY	DATE
A	AAT	21-09-00
1	AAT	21-11-00
2	AAT	11-09-01

**ML4000 STEREO INPUT CIRCUIT C4205 issue 2 SHEET 3 of 3**

**ALLEN&HEATH**  
 Kernick Industrial Estate,  
 Penryn, Cornwall,  
 England. TR10 9LU  
 Tel: (44) (0) 1326 372070 Fax: (44) (0) 1326 365736

ML4000 MASTER CONNECTOR PCB AG4206 issue 2

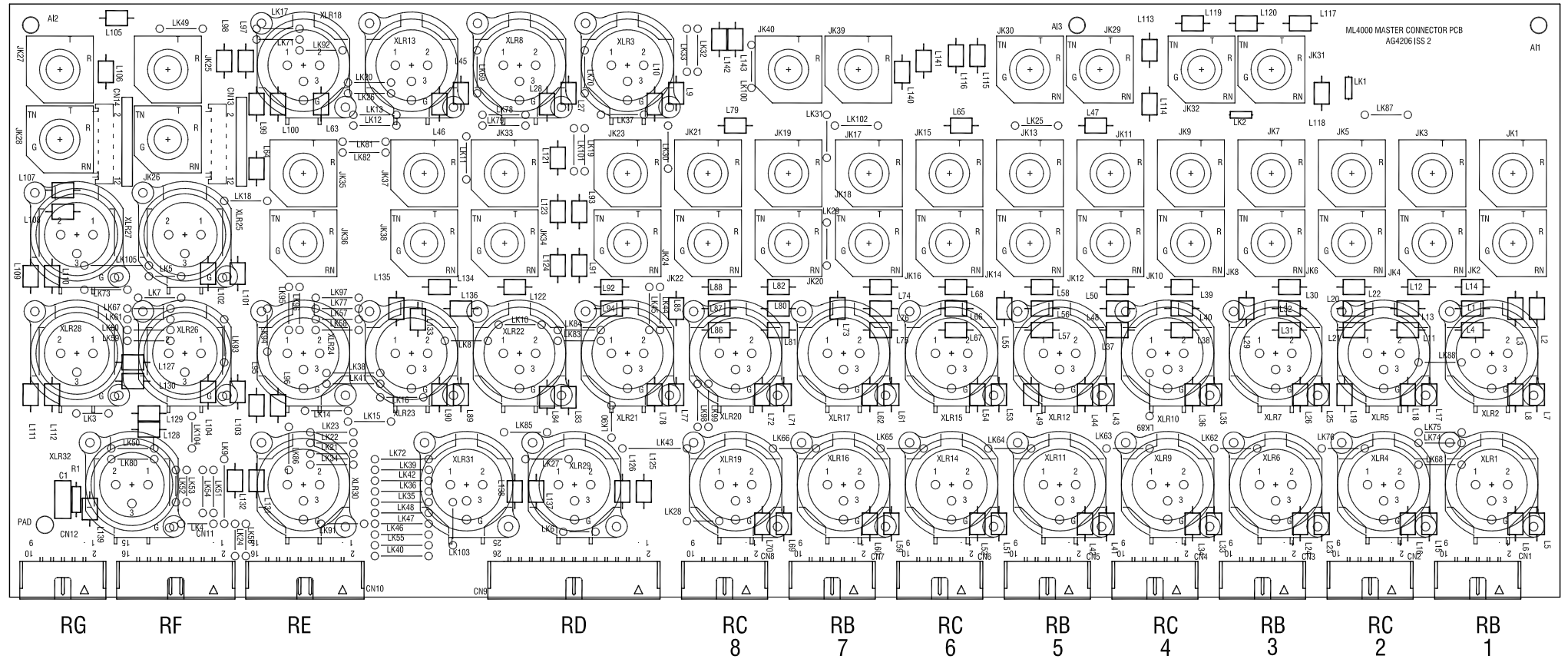

A

B

C

D

E

F

h  
g  
f  
e  
d  
c  
b  
a

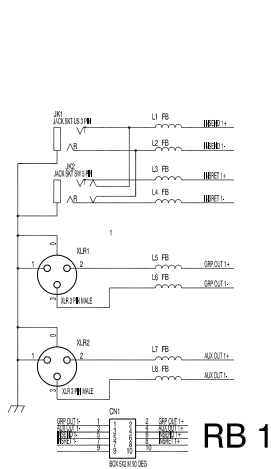

RB 1

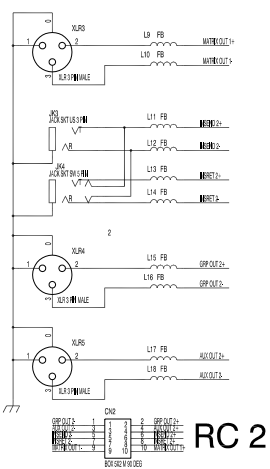

RC 2

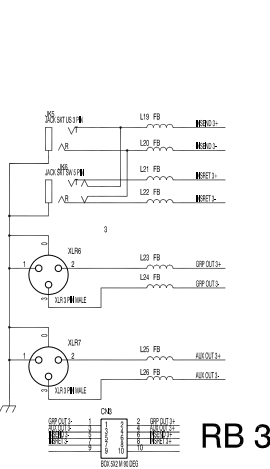

RB 3

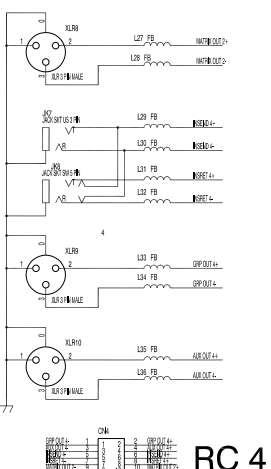

RC 4

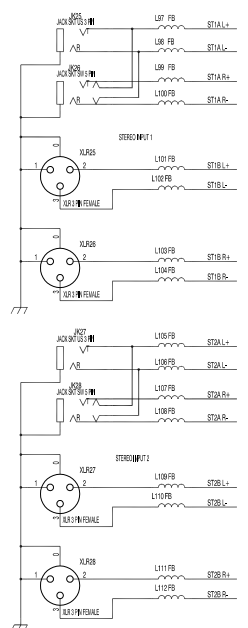

RH 1

RH 2

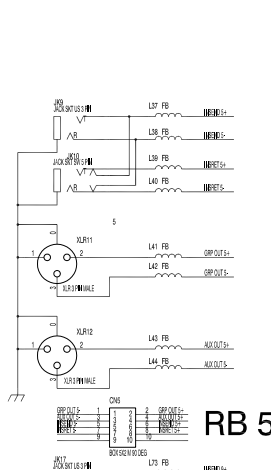
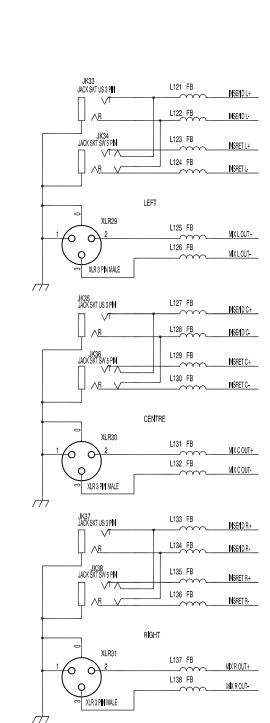

RB 5

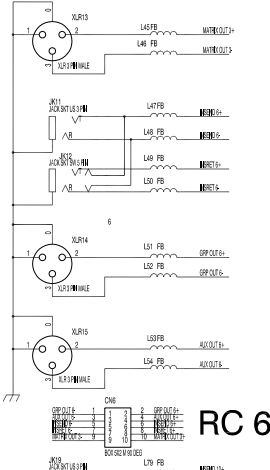

RC 6

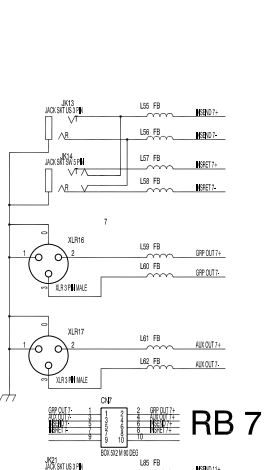

RB 7

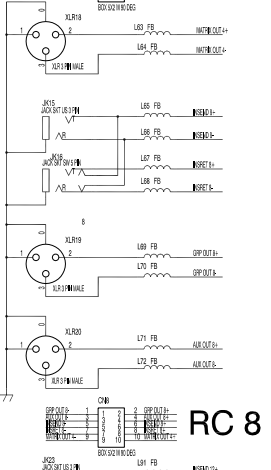

RC 8

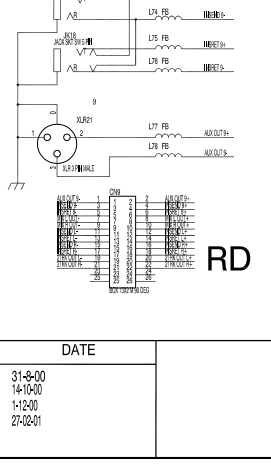
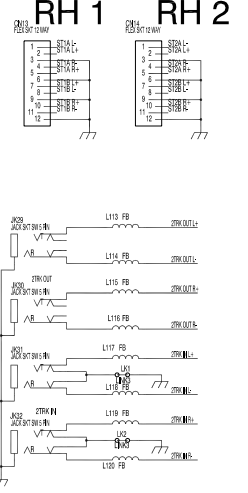

RD

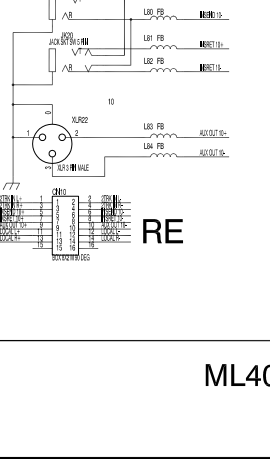

RE

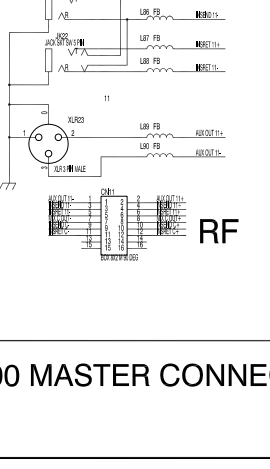

RF

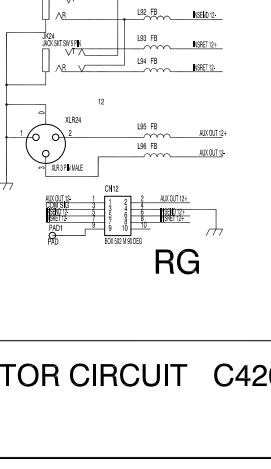

RG

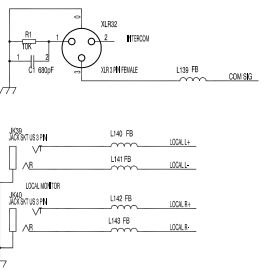

ISSUE	BY	DATE
A	JB	31-5-00
1	JB	14-10-00
1.1	JB	14-12-00
2	JB	22-02-01

ML4000 MASTER CONNECTOR CIRCUIT C4206 issue 2

**ALLEN&HEATH**  
Kernick Industrial Estate,  
Pennyn, Cornwall,  
England, TR10 9LU  
Tel: (44) (0) 1326 372070 Fax: (44) (0) 1326 365736



ODD GROUP PCB (1,3,5,7) AG4208 issue 5

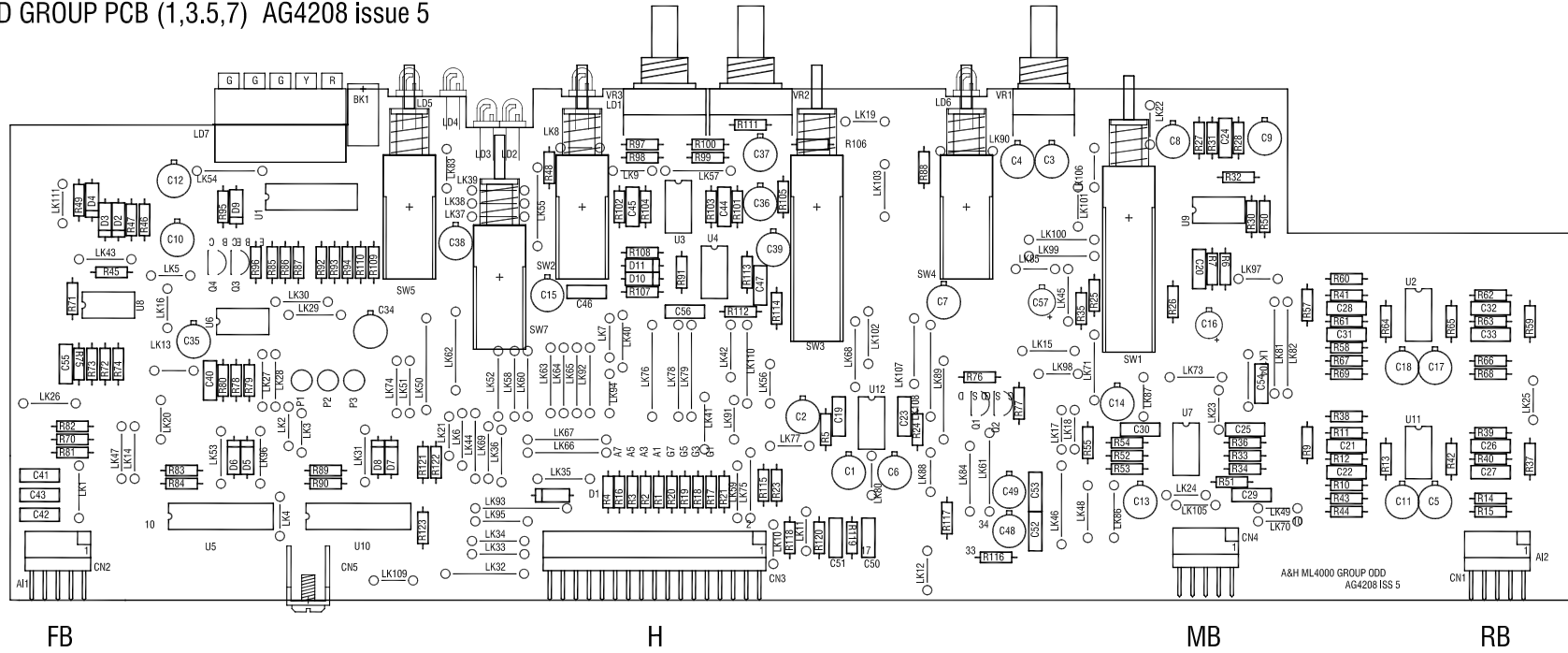

CONNECTORS ARE ON MASTER CONNECTOR PCB AG4206

h  
g  
1  
3  
5  
7  
f  
1  
3  
5  
7  
e  
1  
3  
5  
7  
d  
c  
b  
a

**BUSS ASSIGN - Fit 2 links per board**

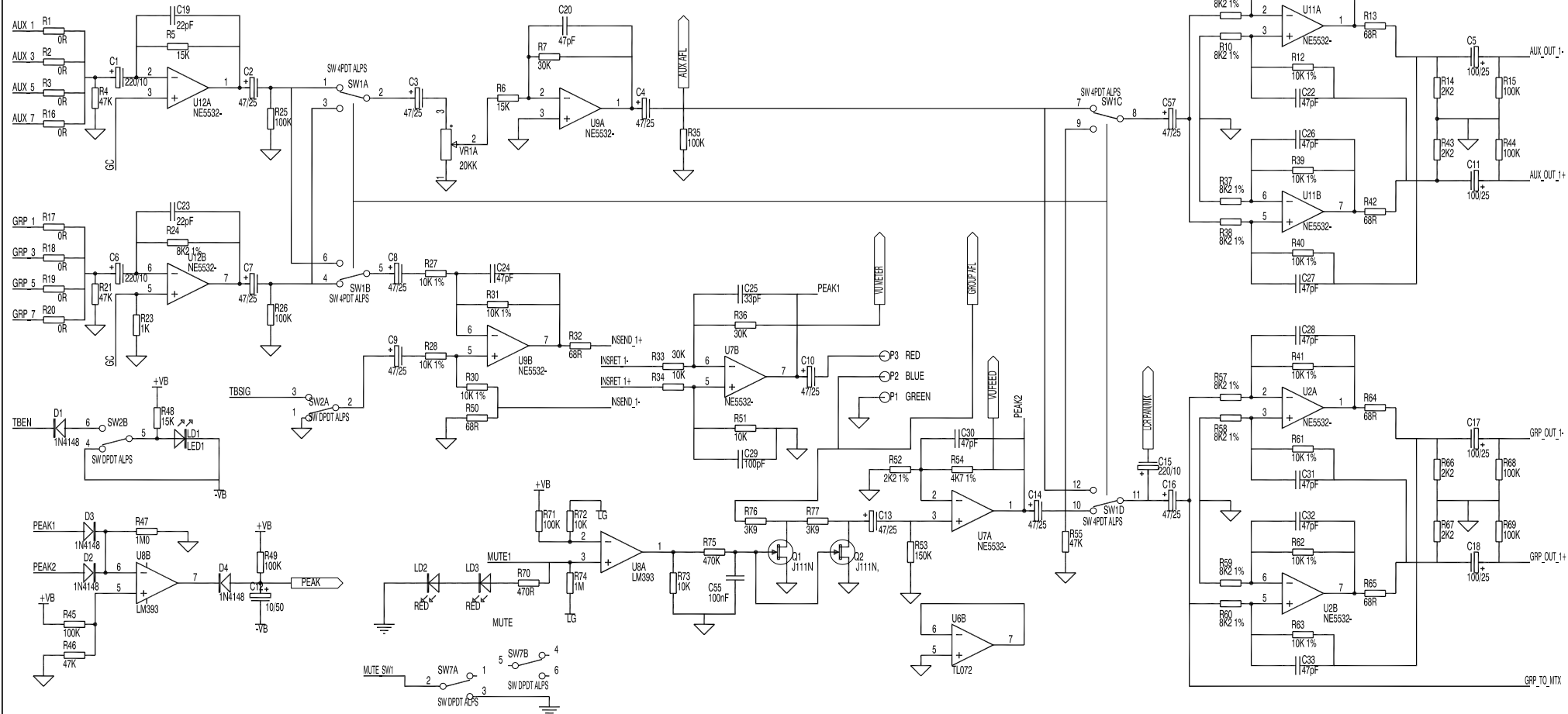

**RB**

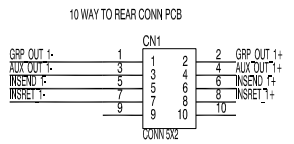

**ML4000 ODD GROUP (1,3,5,7) CIRCUIT C4208 issue 5 SHEET 1 of 2**

ISSUE	BY	DATE
A	AAT	ORIGIN
B	JB	2-10-00
1	JB	10-14-00
2	JB	21-14-00
3	AAT	08-12-00
4	AAT	30-04-01
5	AAT	21-03-01

**ALLEN & HEATH**  
 Kemlock Industrial Estate,  
 Pennyn, Cornwall,  
 England, TR10 9LU  
 Tel: (44) (0) 1326 372070 Fax: (44) (0) 1326 365736



EVEN GROUP PCB (2,4,6,8) AG4209 issue 4

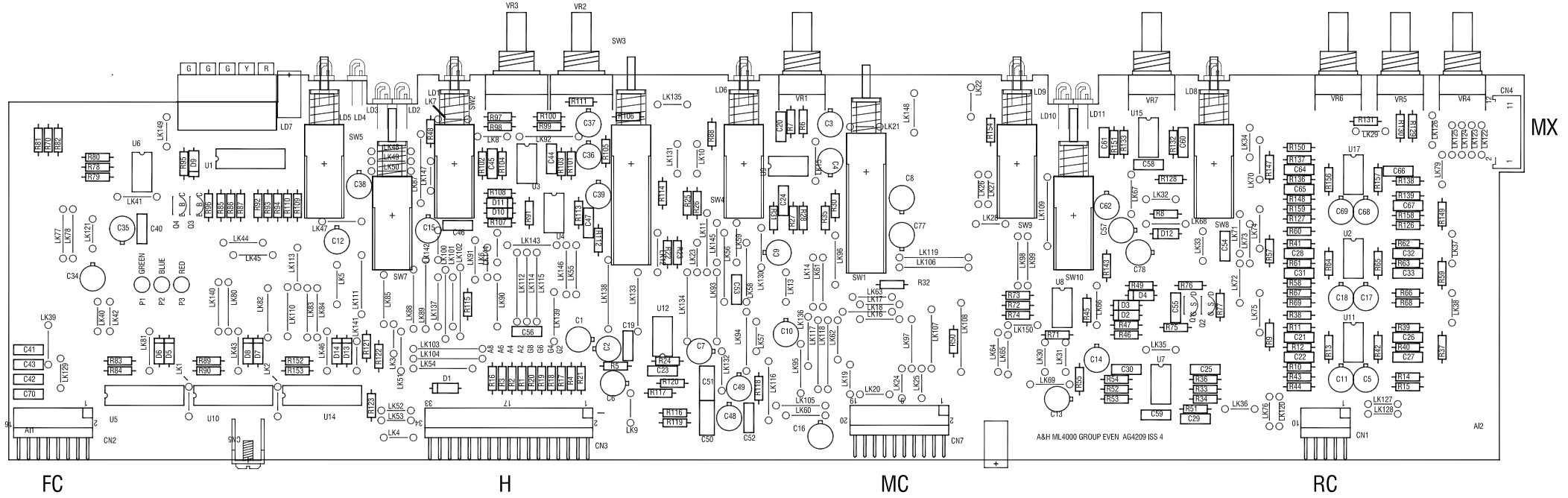

CN1  
12 WAY FFC  
TO MAIN PCB  
MX

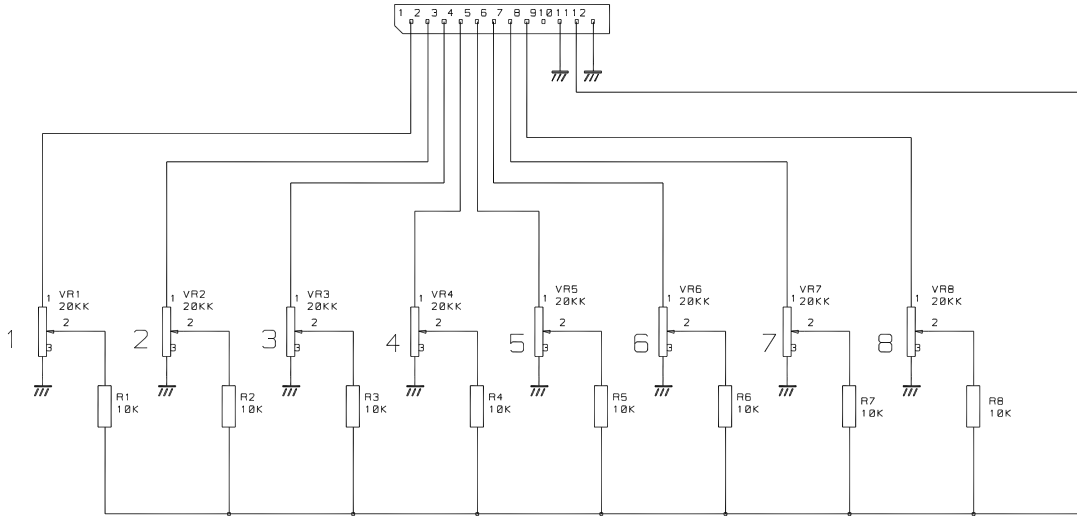

GROUP SUB2 PCB AG3719 issue 1

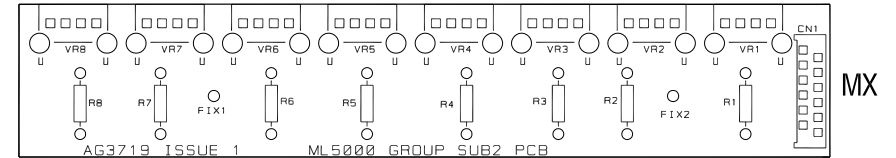

h

# RC

10 WAY TO REAR CONN PCB

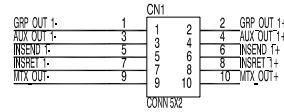

## BUSS ASSIGN - Fit 2 links per board

g

2

4

6

8

f

2

4

6

8

e

2

4

6

8

d

2

4

6

8

c

2

4

6

8

b

2

4

6

8

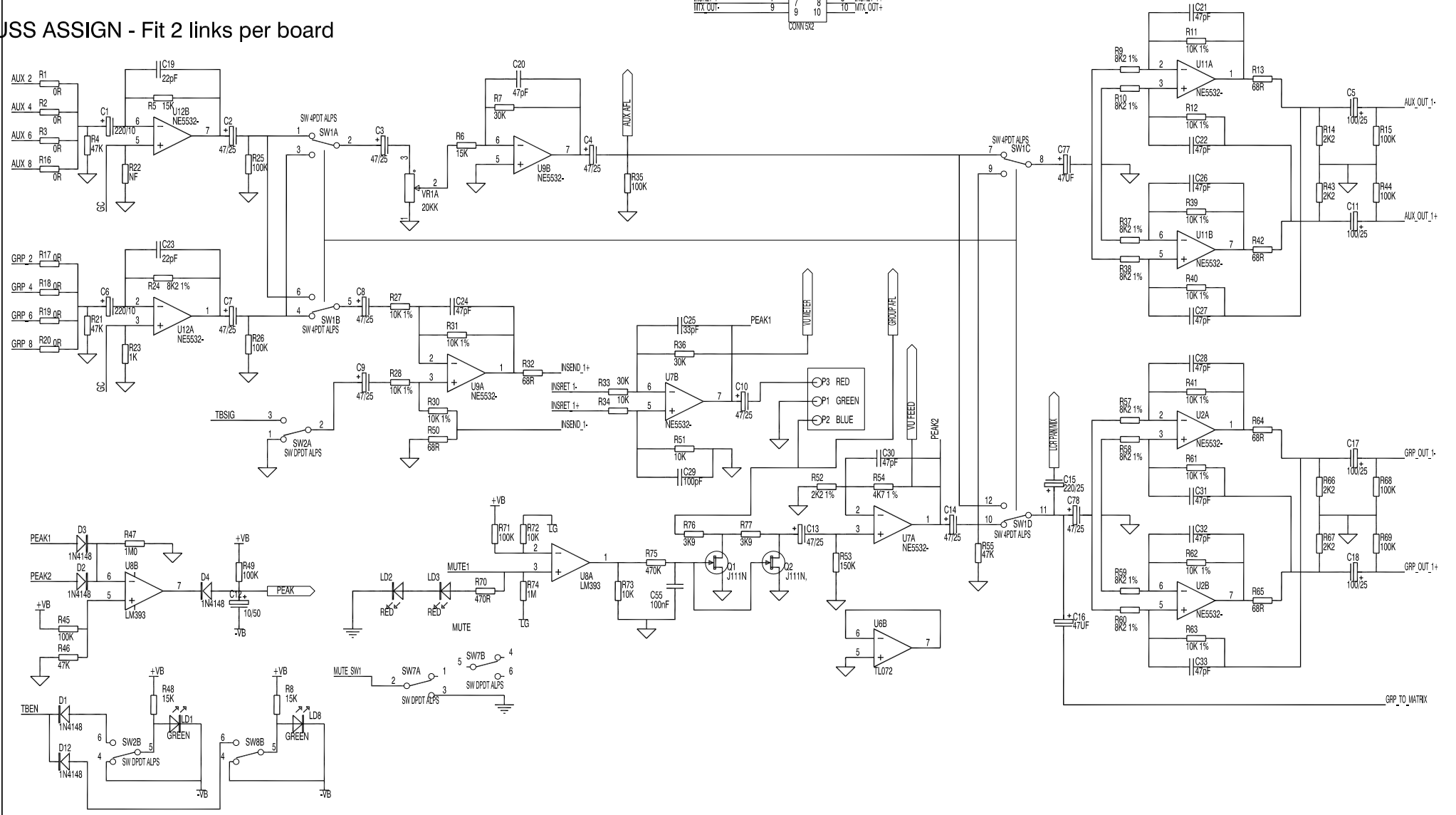

g

2

4

6

8

f

2

4

6

8

e

2

4

6

8

d

2

4

6

8

c

2

4

6

8

b

2

4

6

8

a

## ML4000 EVEN GROUP CIRCUIT C4209 issue 4 SHEET 1 of 3

**ALLEN&HEATH**  
 Kernick Industrial Estate,  
 Penryn, Cornwall,  
 England, TR10 9LU  
 Tel: (44) (0) 1326 372070 Fax: (44) (0) 1326 365736

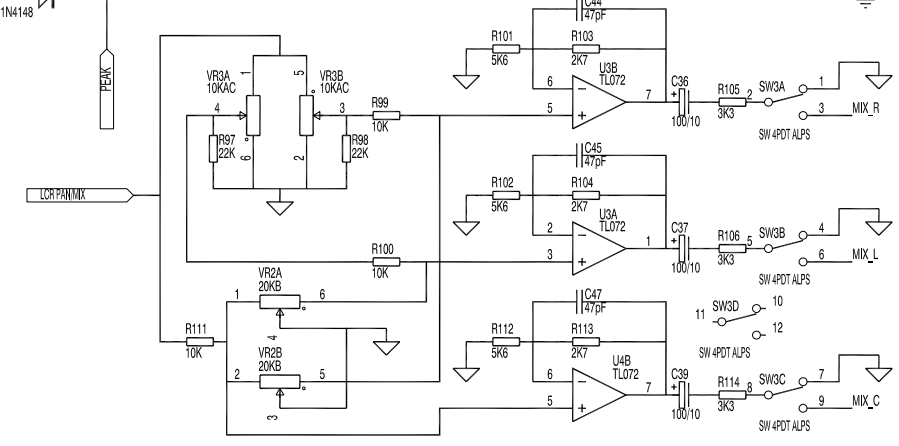
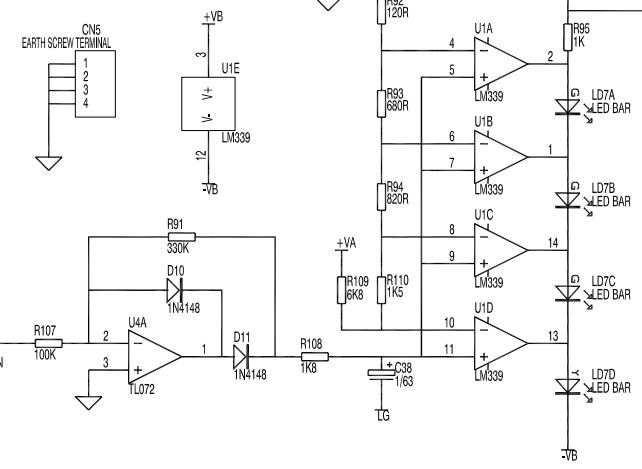
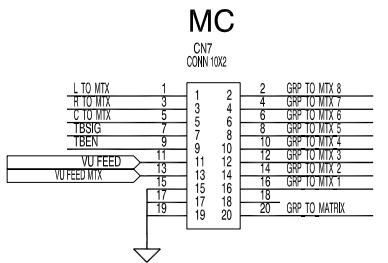
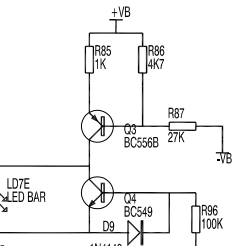
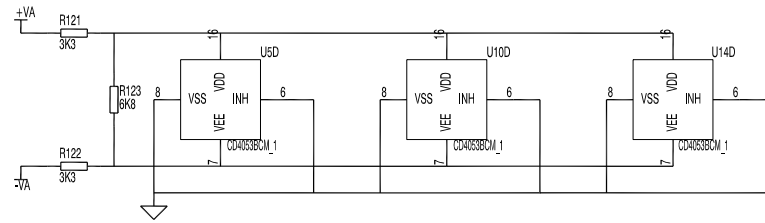
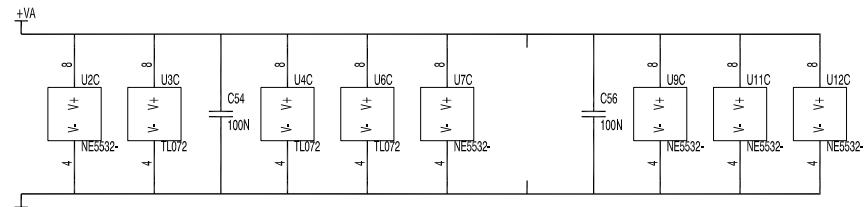
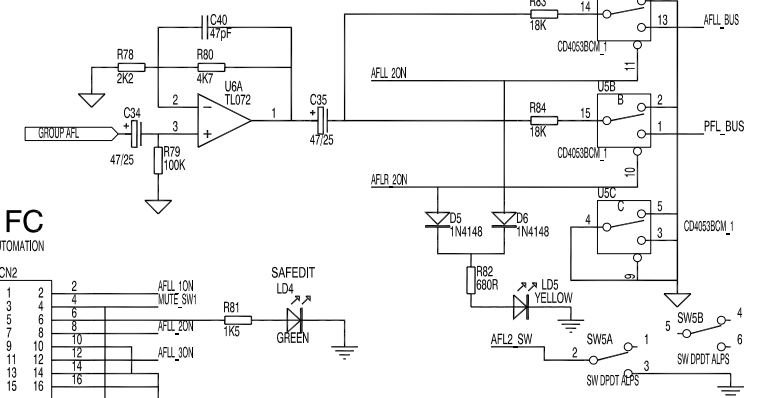
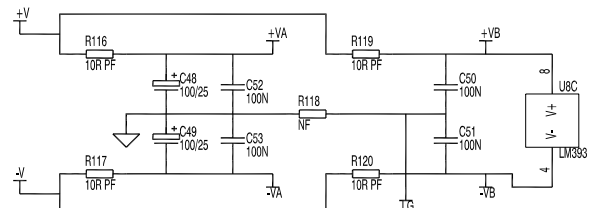
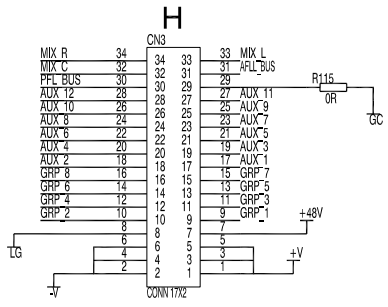

ISSUE	BY	DATE
A	AAT	22-08-00
B	JB	2-10-00
1	JB	10-11-00
2	JB	20-11-00
3	MC	08-12-00
4	AAT	30-01-01

ML4000 EVEN GROUP CIRCUIT C4209 issue 4 SHEET 2 of 3

**ALLEN&HEATH**  
 Kennick Industrial Estate,  
 Penryn, Cornwall,  
 England, TR10 9LU  
 Tel: (44) (0) 1326 372070 Fax: (44) (0) 1326 365736

h  
g  
f  
e  
d  
c  
b  
a

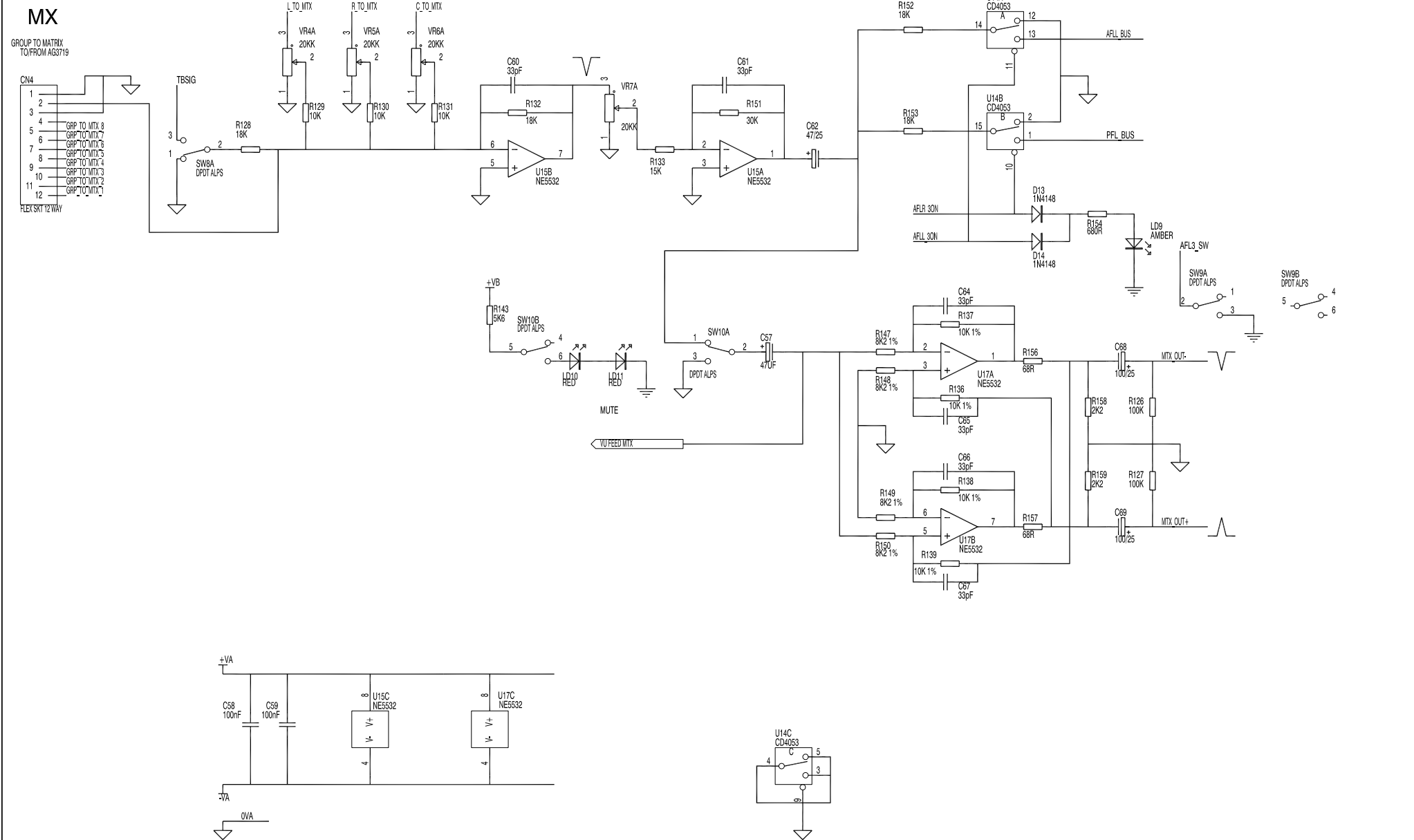

ISSUE	BY	DATE
A	AAT	22-08-00
B	JB	2-10-00
1	JB	10-11-00
2	JB	20-11-00
3	MC	08-12-00
4	AAT	30-01-01

ML4000 EVEN GROUP CIRCUIT C4209 issue 4 SHEET 3 of 3

**ALLEN & HEATH**  
 Kennick Industrial Estate,  
 Penryn, Cornwall,  
 England, TR10 9LU  
 Tel: (44) (0) 1326 372070 Fax: (44) (0) 1326 365736

ML4000 AUX9 PCB AG4212 issue 3

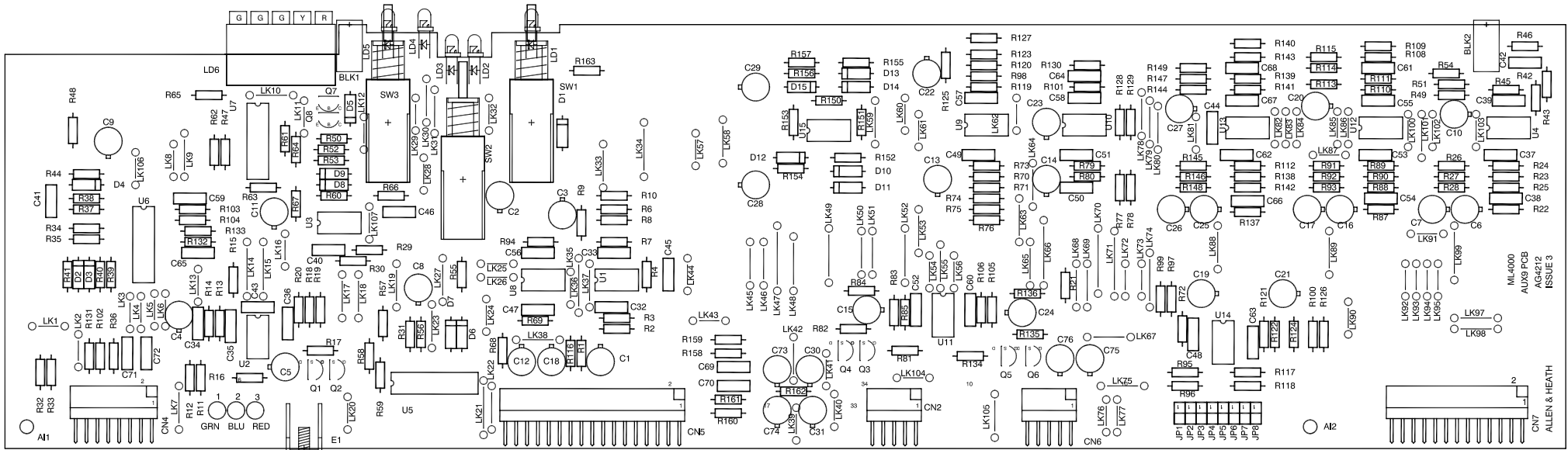

ML4000  
AUX9 PCB  
AG4212  
ISSUE 3

ALLEN & HEATH  
CN7

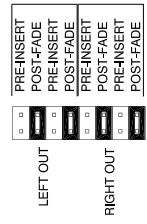

2TRK SOURCE LINK OPTIONS



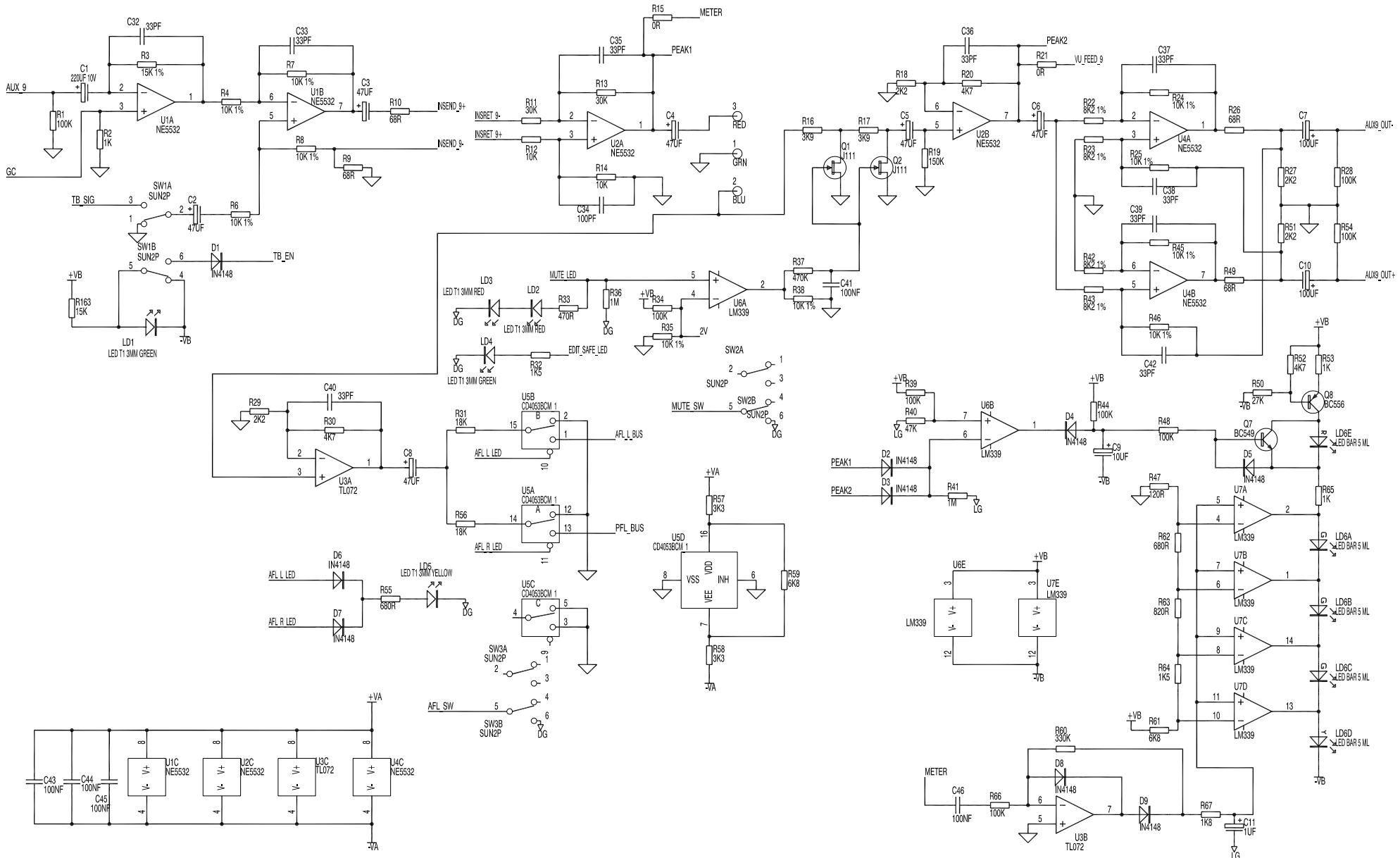

ISSUE	BY	DATE

ML4000 AUX9 CIRCUIT C4212 issue 3 SHEET 1 of 3

**ALLEN&HEATH**  
 Kernick Industrial Estate,  
 Penryn, Cornwall,  
 England, TR10 9LU  
 Tel: (44) (0) 1326 372070 Fax: (44) (0) 1326 365736

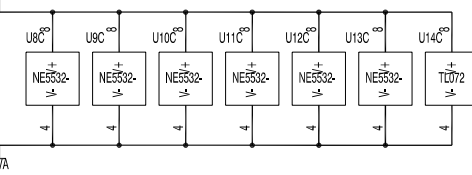
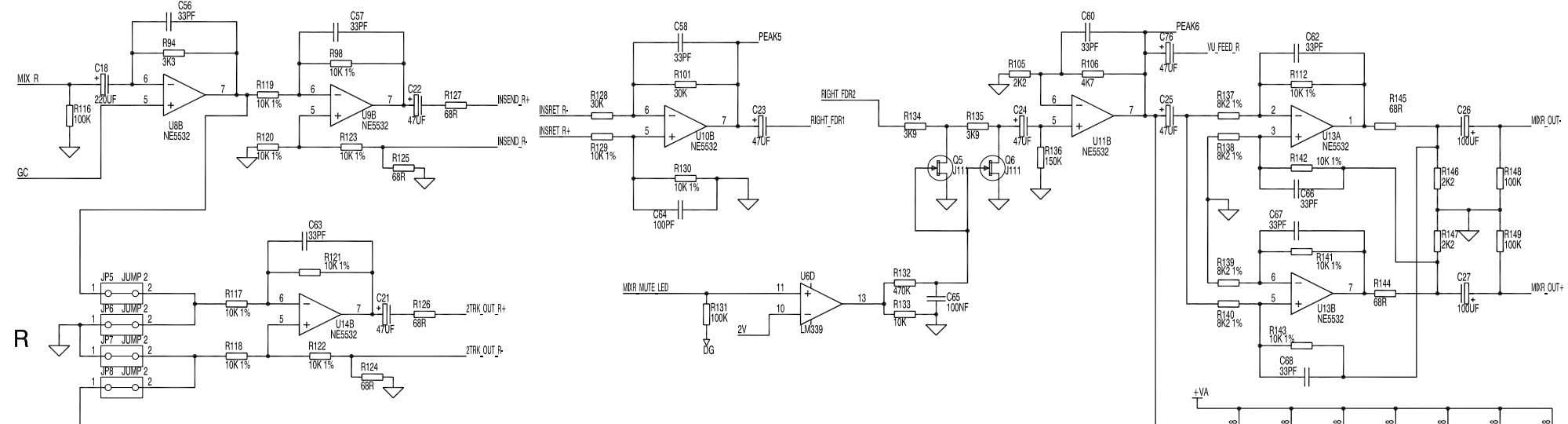
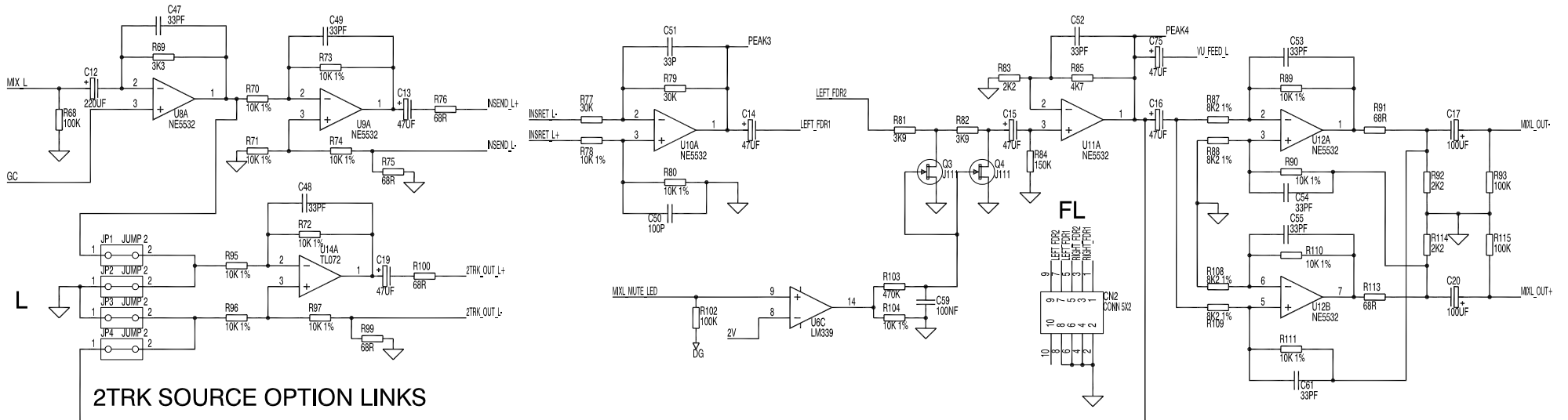

ISSUE	BY	DATE

ML4000 AUX9 CIRCUIT C4212 issue 3 SHEET 2 of 3

**ALLEN&HEATH**  
 Kernick Industrial Estate,  
 Penryn, Cornwall,  
 England, TR10 9LU  
 Tel: (44) (0) 1326 372070 Fax: (44) (0) 1326 365736

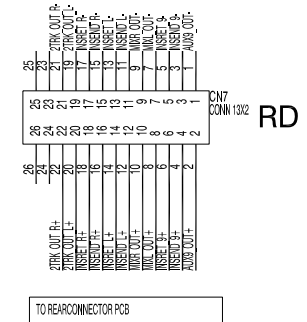
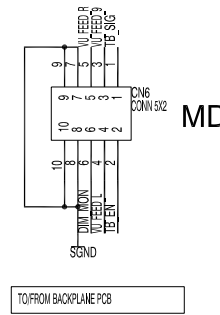
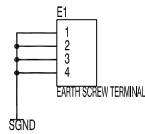
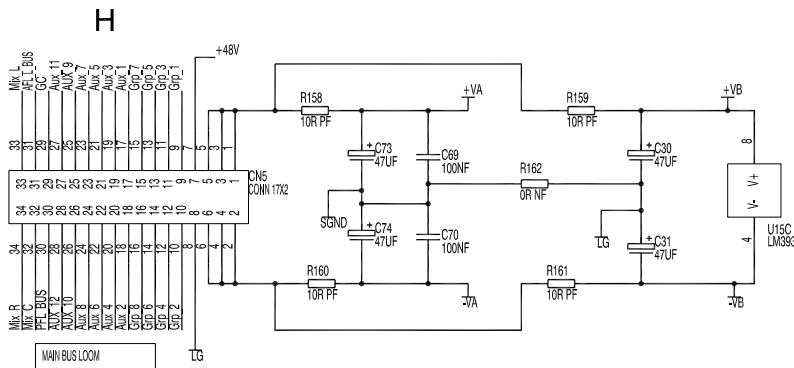
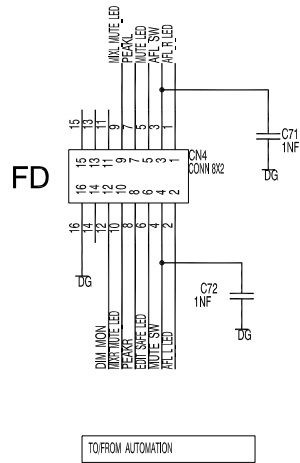
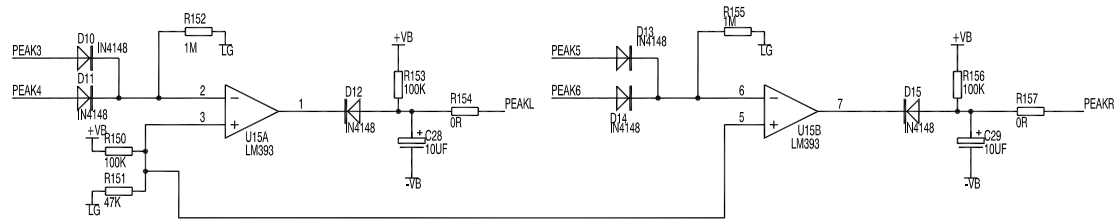

ISSUE	BY	DATE

ML4000 AUX9 CIRCUIT C4212 issue 3 SHEET 3 of 3

**ALLEN&HEATH**  
 Kennick Industrial Estate,  
 Penryn, Cornwall,  
 England, TR10 9LU  
 Tel: (44) (0) 1326 372070 Fax: (44) (0) 1326 365736

ML4000 AUX10 PCB AG4210 issue 3

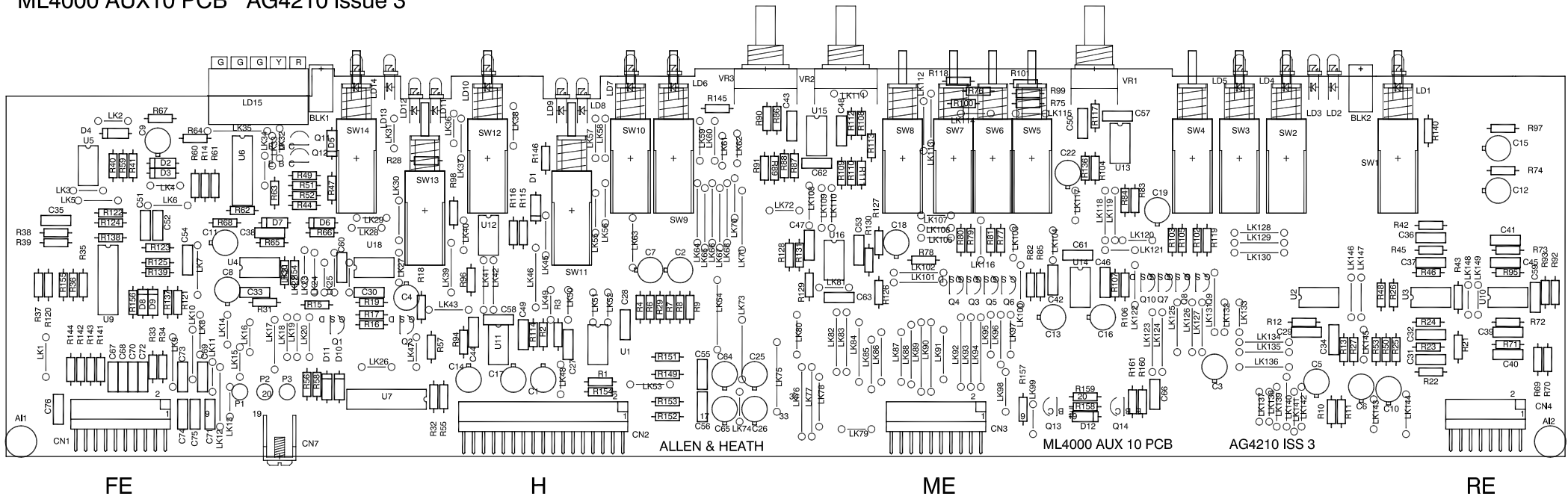

A

B

C

D

E

F

G

H

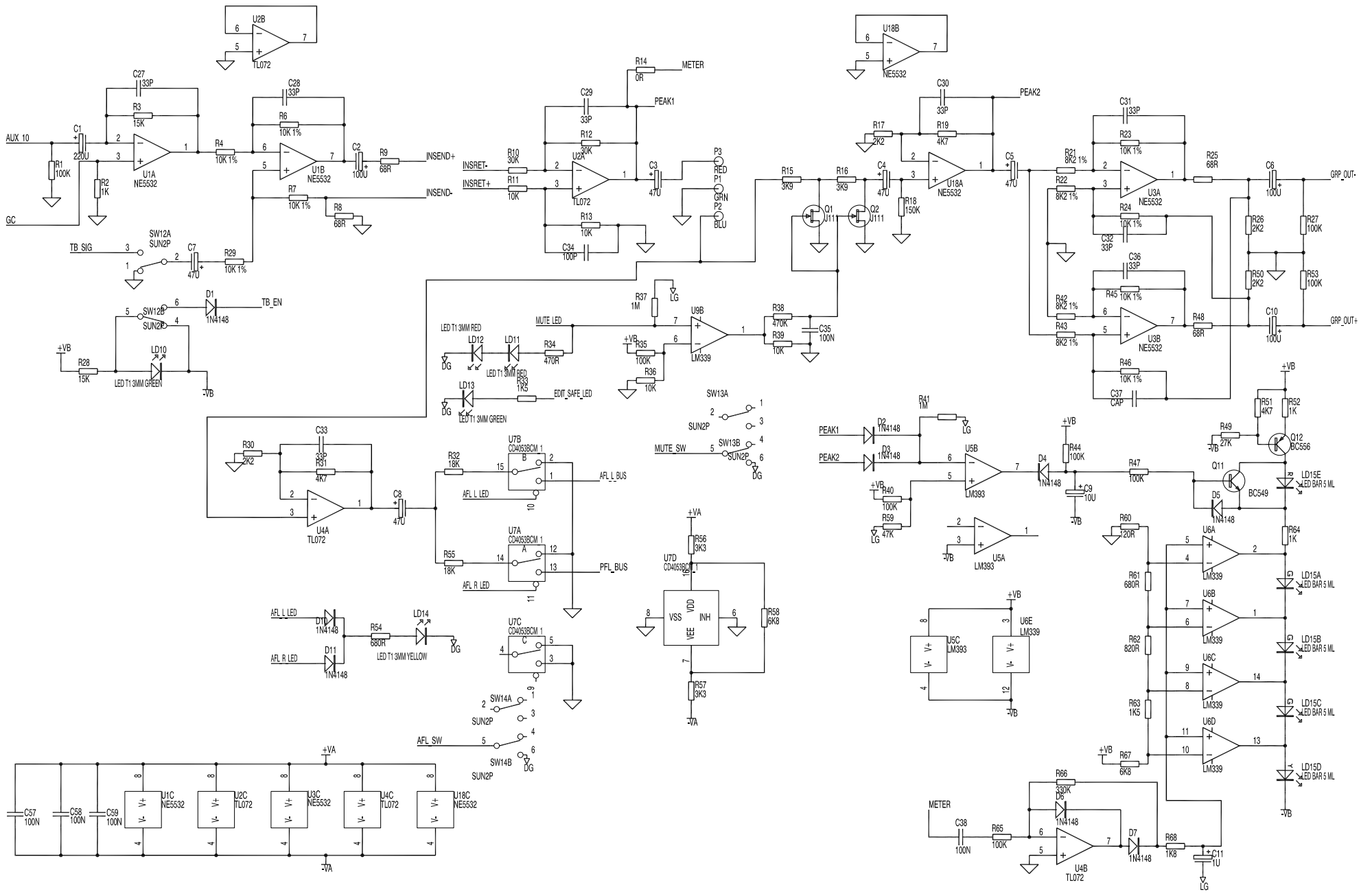

ISSUE	BY	DATE

ML4000 AUX10 CIRCUIT C4210 issue 3 SHEET 1 of 3

**ALLEN&HEATH**  
 Kernick Industrial Estate,  
 Penryn, Cornwall,  
 England, TR10 9LU  
 Tel: (44) (0) 1326 372070 Fax: (44) (0) 1326 365736

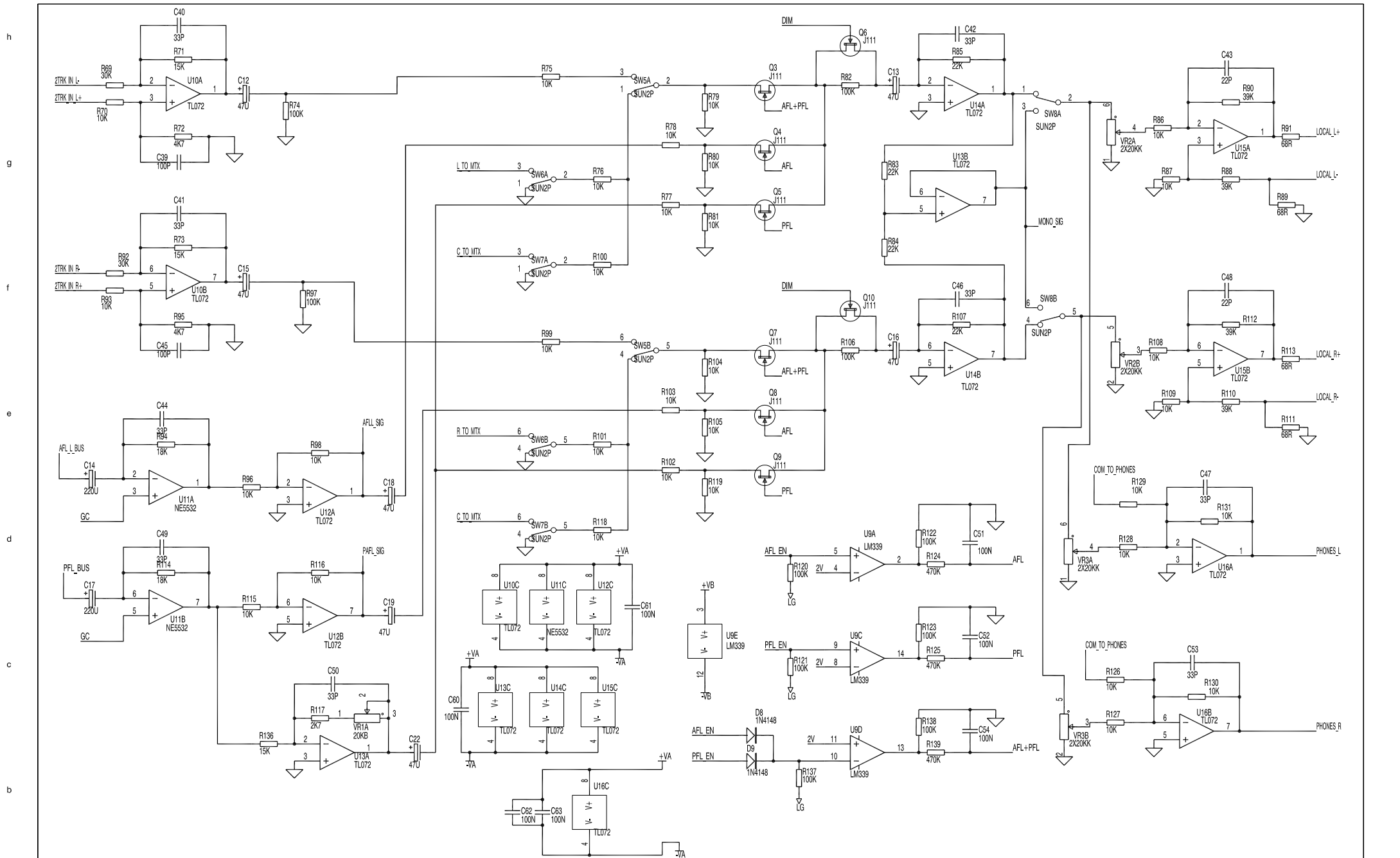

ISSUE	BY	DATE

ML4000 AUX10 CIRCUIT C4210 issue 3 SHEET 2 of 3

**ALLEN&HEATH**  
 Kernick Industrial Estate,  
 Penryn, Cornwall,  
 England, TR10 9LU  
 Tel: (44) (0) 1326 372070 Fax: (44) (0) 1326 365736

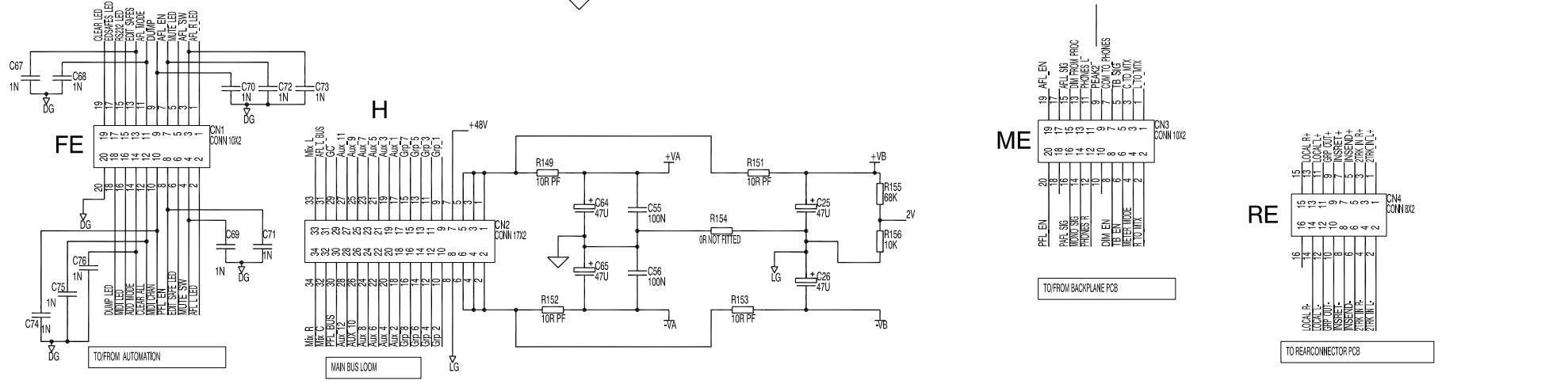
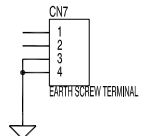
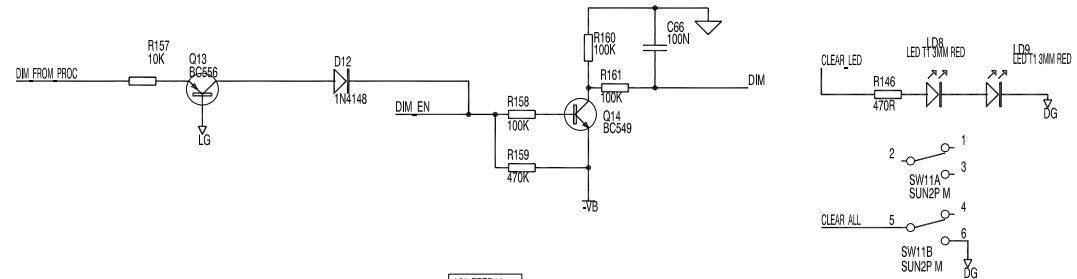
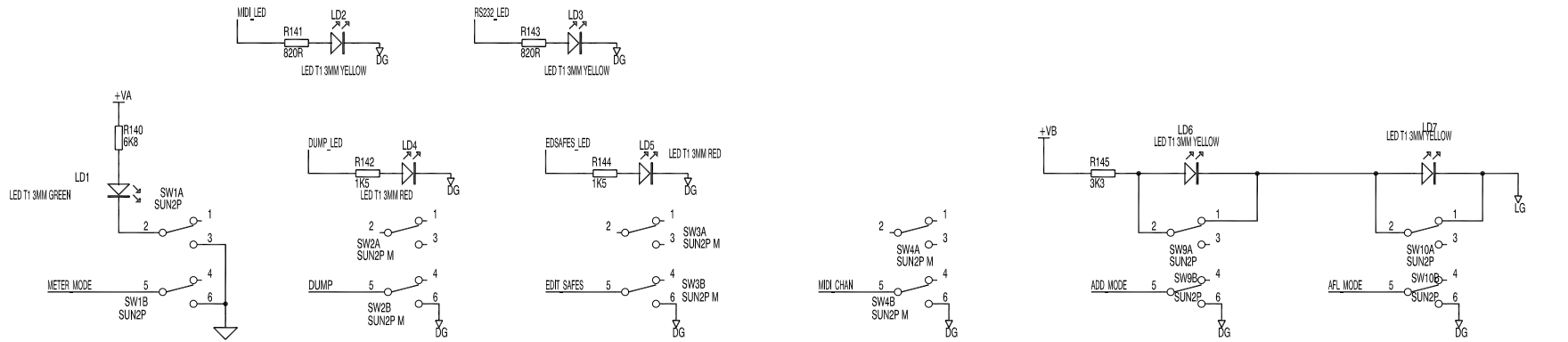

ISSUE	BY	DATE

ML4000 AUX10 CIRCUIT C4210 issue 3 SHEET 3 of 3

**ALLEN&HEATH**  
 Kernick Industrial Estate,  
 Penryn, Cornwall,  
 England, TR10 9LU  
 Tel: (44) (0) 1326 372070 Fax: (44) (0) 1326 365736

ML4000 AUX11 PCB AG4213 issue 3

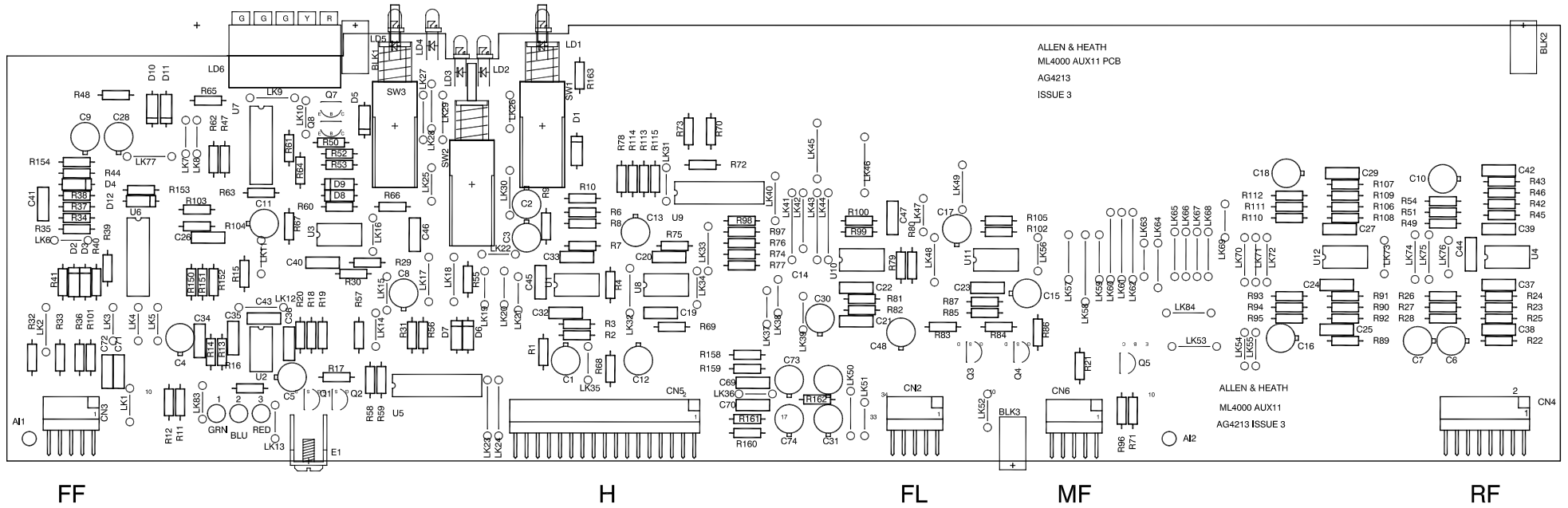



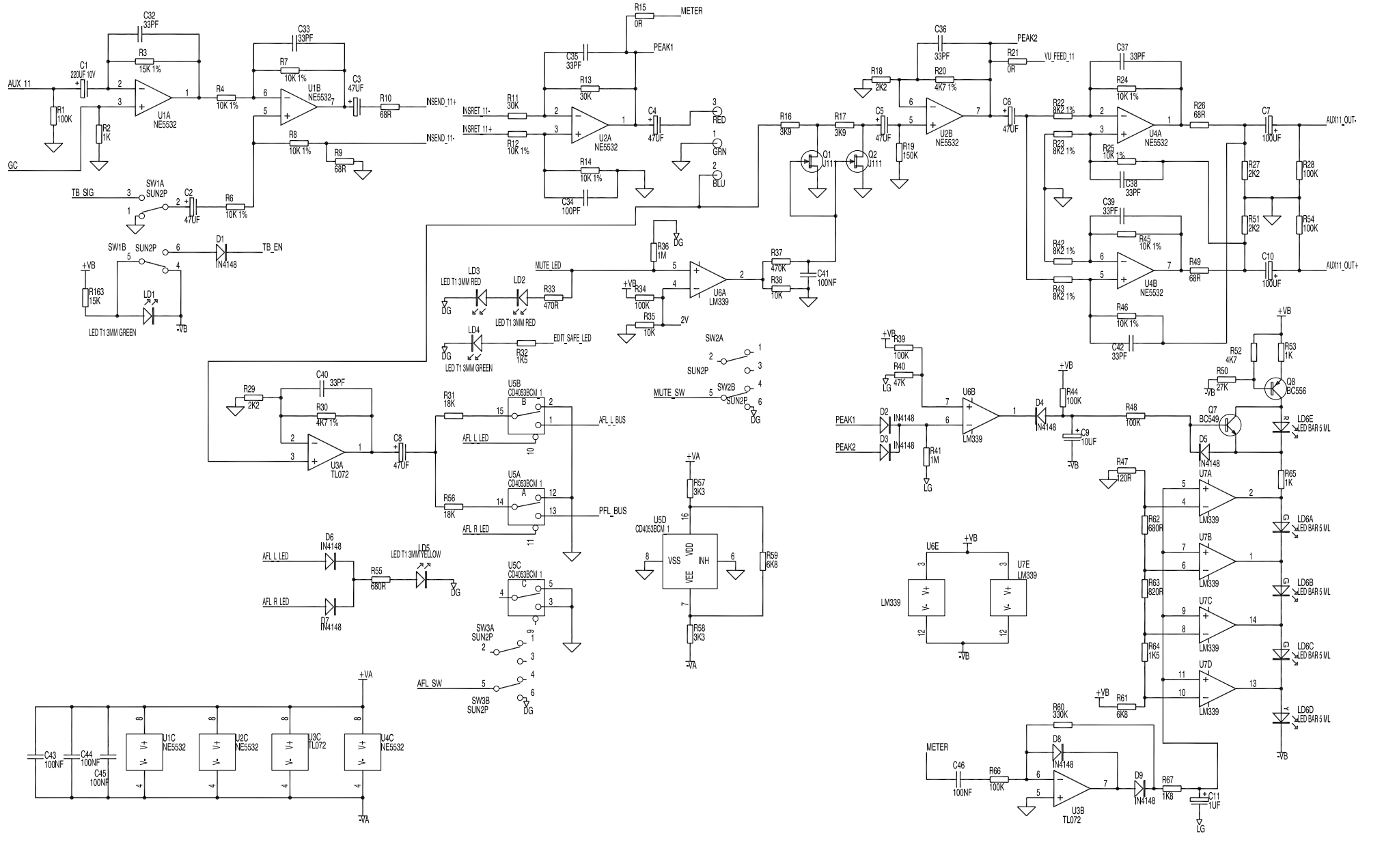

ISSUE	BY	DATE

ML4000 AUX11 CIRCUIT C4213 issue 3 SHEET 1 of 3

**ALLEN&HEATH**  
 Kernick Industrial Estate,  
 Penryn, Cornwall,  
 England, TR10 9LU  
 Tel: (44) (0) 1326 372070 Fax: (44) (0) 1326 365736

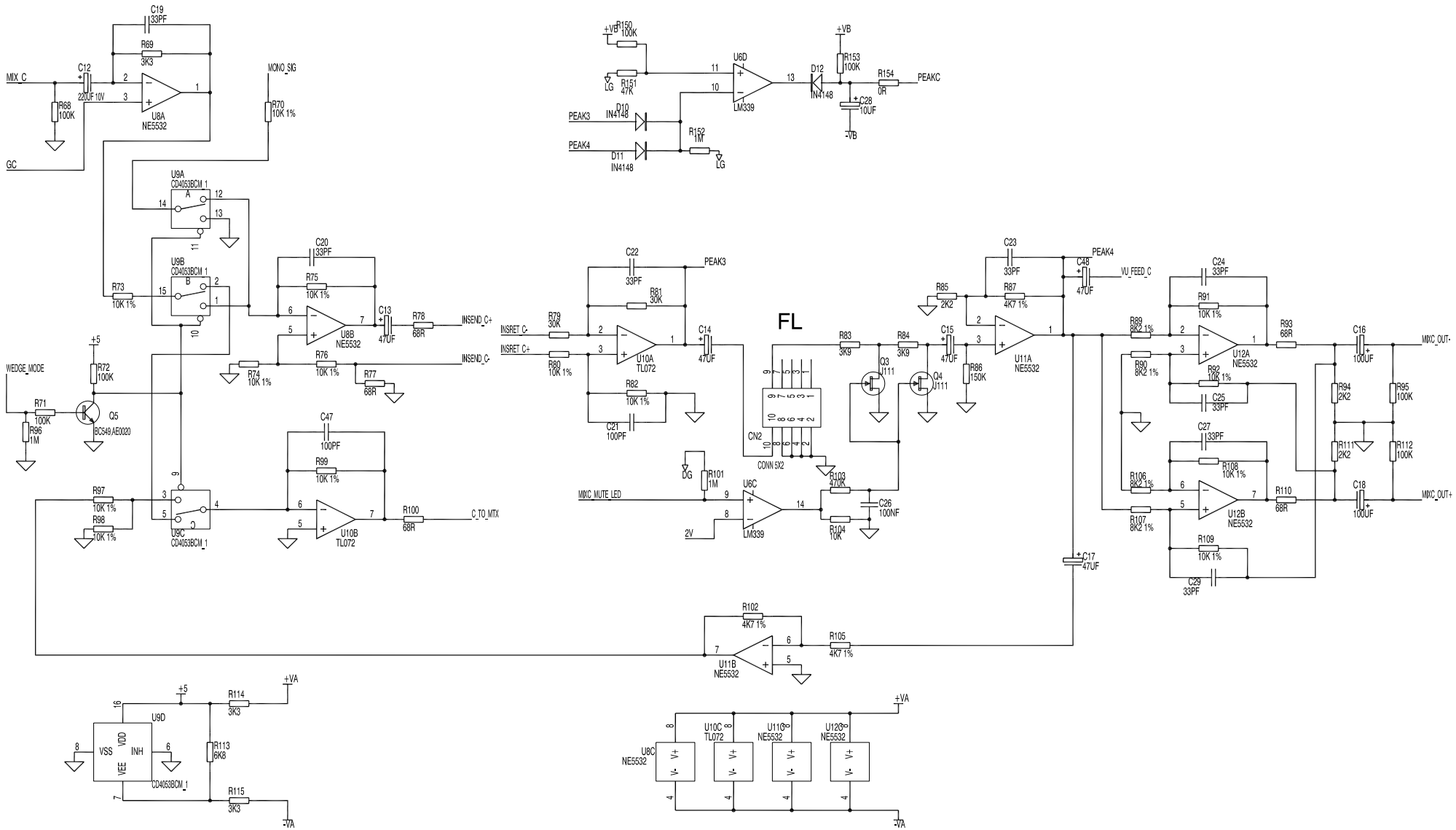

ISSUE	BY	DATE

ML4000 AUX11 CIRCUIT C4213 issue 3 SHEET 2 of 3

**ALLEN&HEATH**  
 Kernick Industrial Estate,  
 Penryn, Cornwall,  
 England, TR10 9LU  
 Tel: (44) (0) 1326 372070 Fax: (44) (0) 1326 365736

h  
g  
f  
e  
d  
c  
b  
a

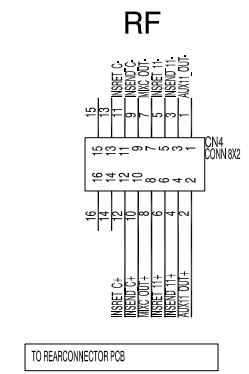
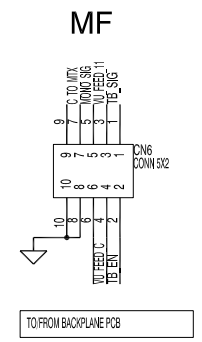
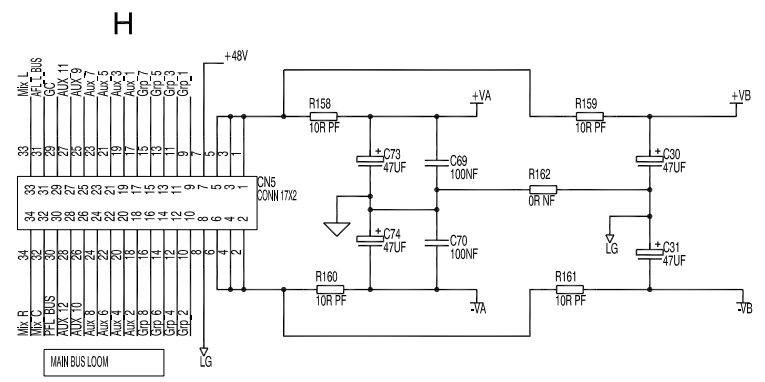
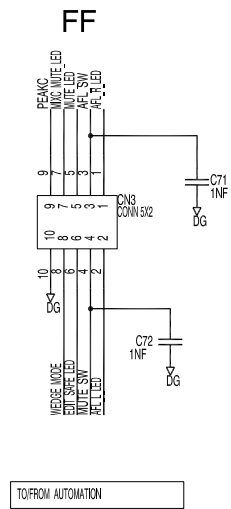

ISSUE	BY	DATE

ML4000 AUX11 CIRCUIT C4213 issue 3 SHEET 3 of 3

**ALLEN & HEATH**  
 Kernick Industrial Estate,  
 Penryn, Cornwall,  
 England, TR10 9LU  
 Tel: (44) (0) 1326 372070 Fax: (44) (0) 1326 365736

ML4000 AUX12 PCB AG4211 issue 3

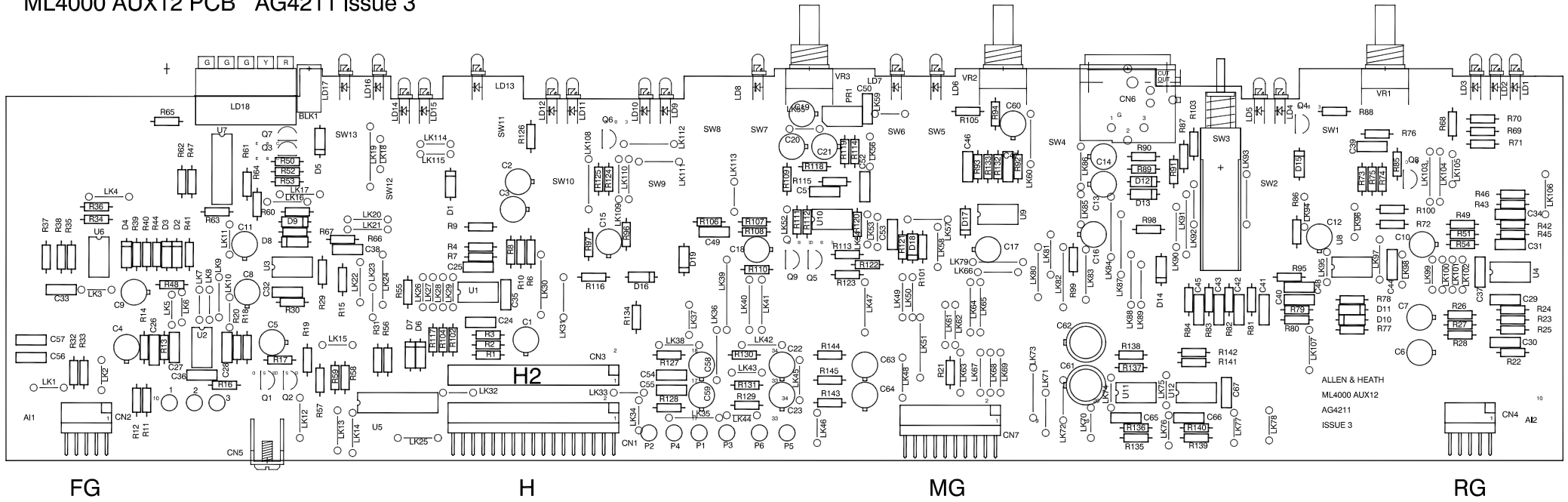

A

B

C

D

E

F

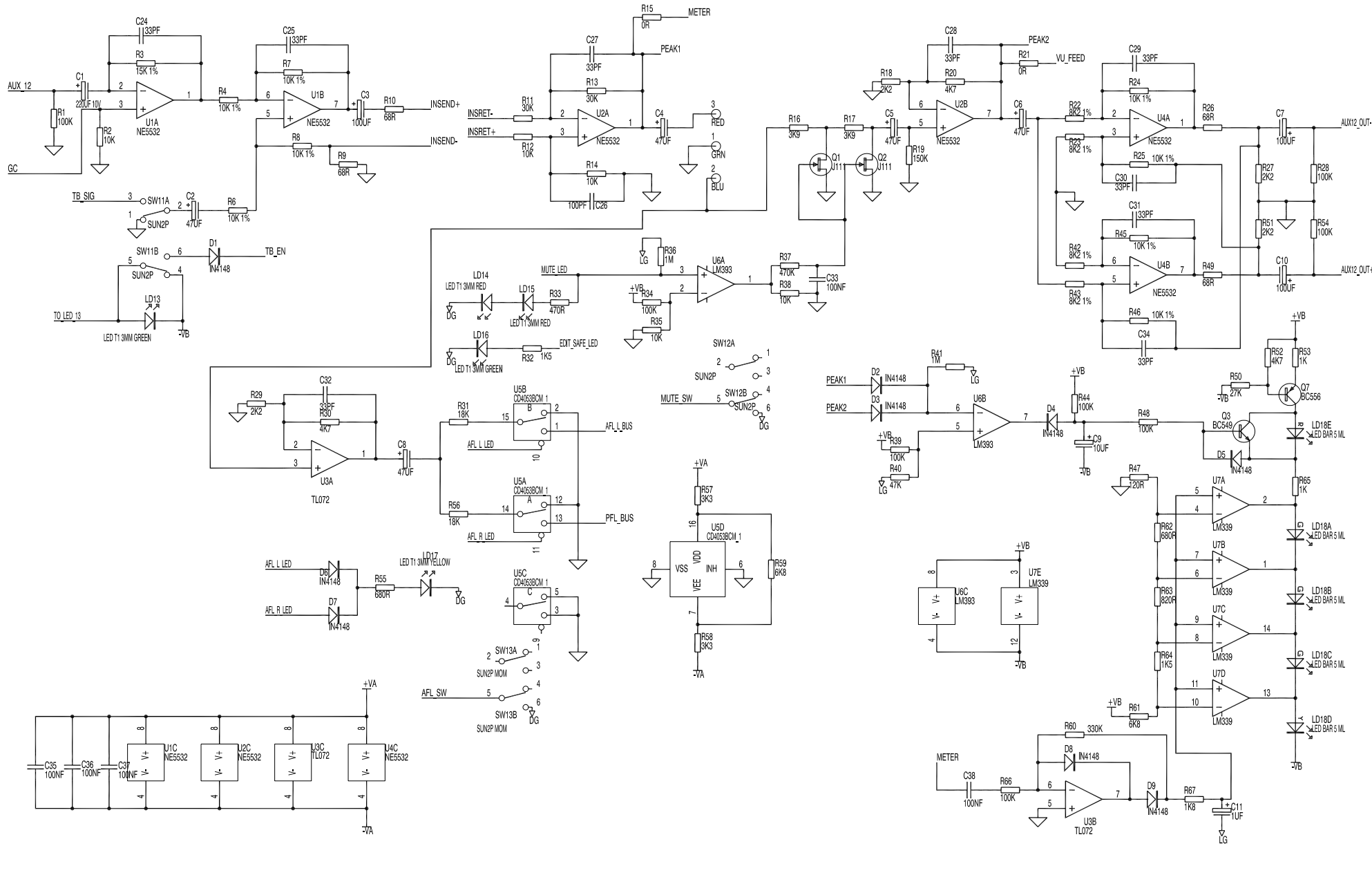

ISSUE	BY	DATE

ML4000 AUX12 CIRCUIT C4211 issue 3 SHEET 1 of 3

**ALLEN&HEATH**  
 Kernick Industrial Estate,  
 Penryn, Cornwall,  
 England, TR10 9LU  
 Tel: (44) (0) 1326 372070 Fax: (44) (0) 1326 365736

h  
g  
f  
e  
d  
c  
b  
a

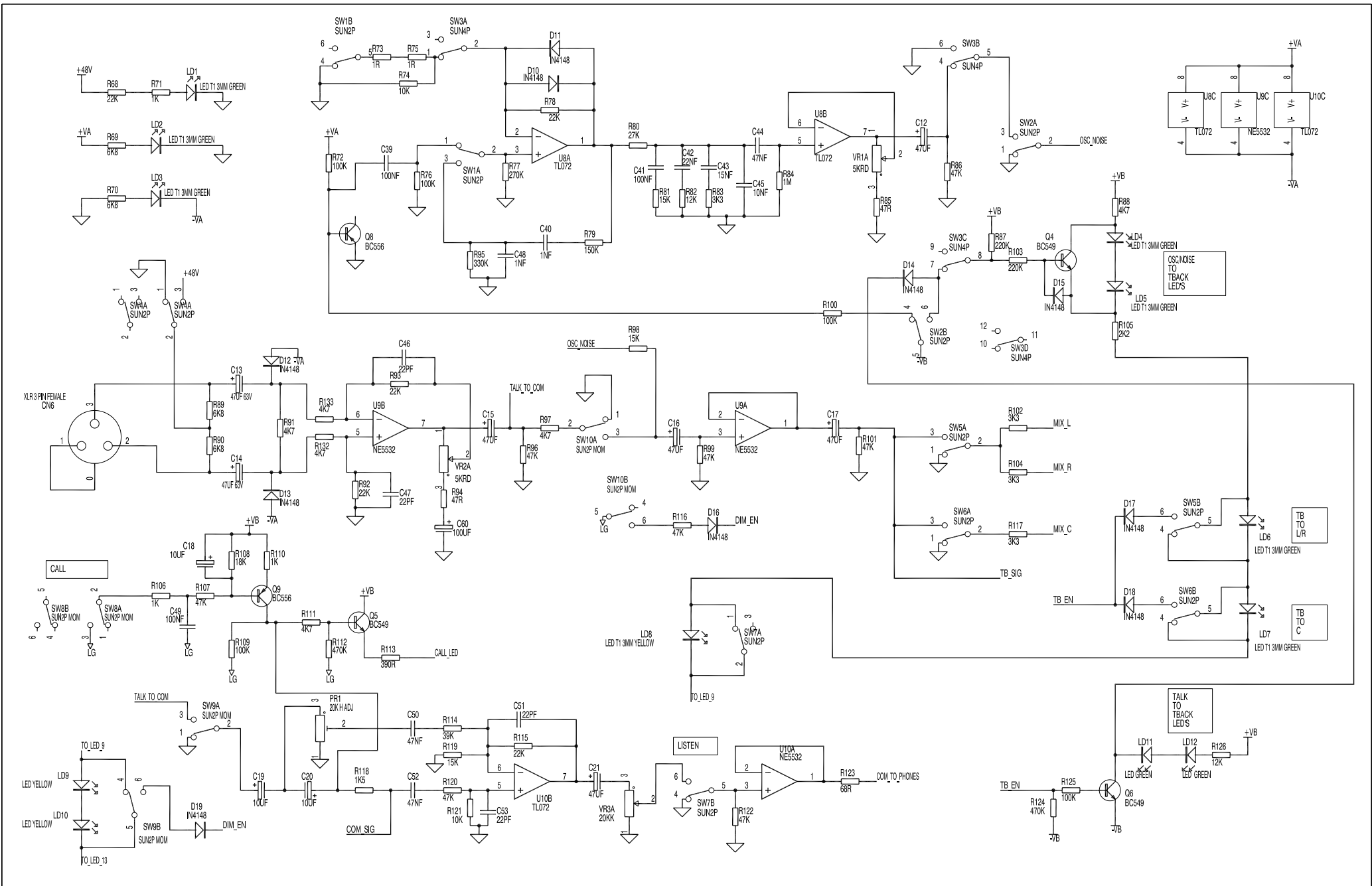

ISSUE	BY	DATE

ML4000 AUX12 CIRCUIT C4211 issue 3 SHEET 2 of 3

**ALLEN&HEATH**  
 Kernick Industrial Estate,  
 Penryn, Cornwall,  
 England, TR10 9LU  
 Tel: (44) (0) 1326 372070 Fax: (44) (0) 1326 365736

h  
g  
f  
e  
d  
c  
b  
a

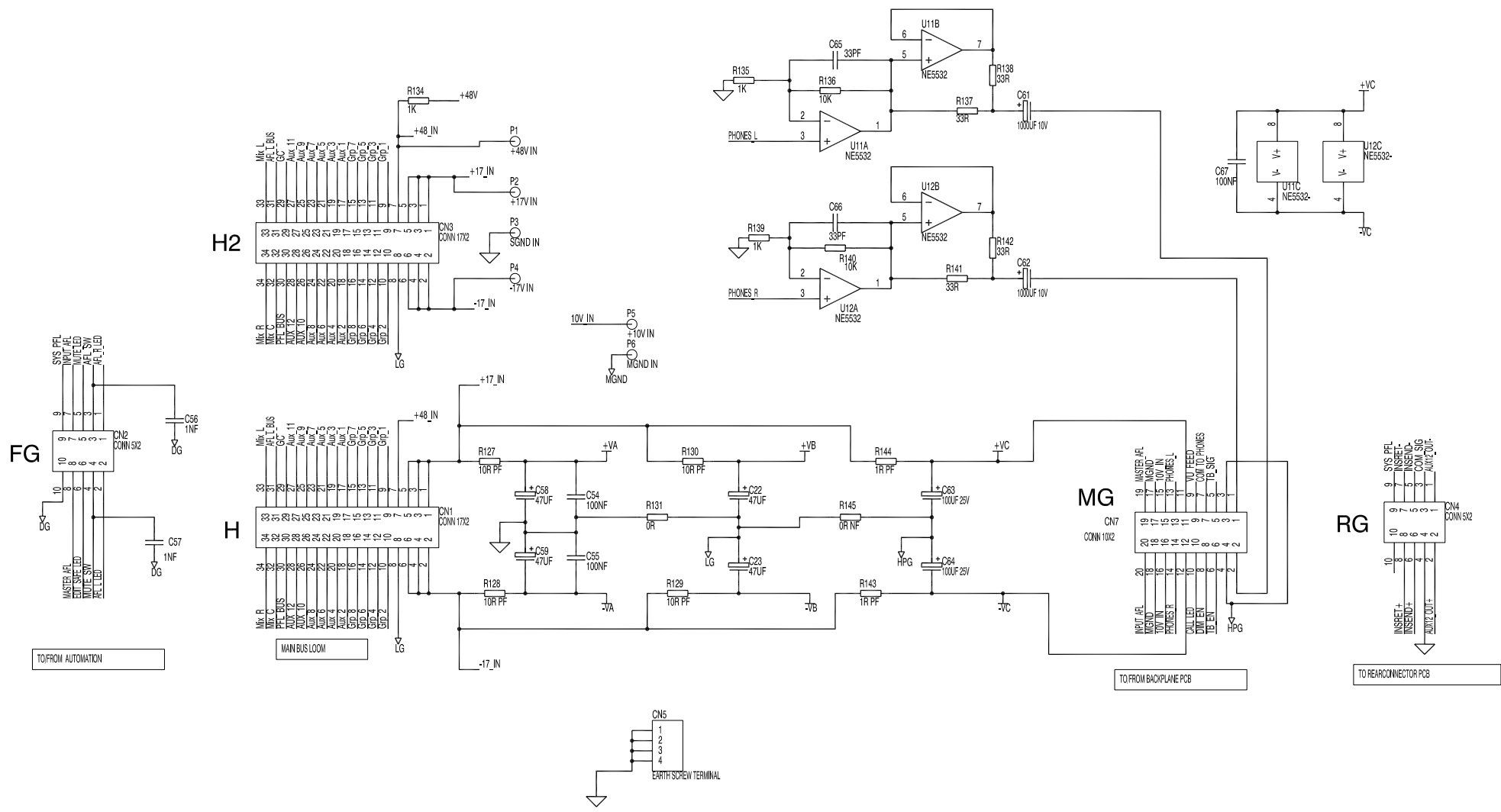

ISSUE	BY	DATE

ML4000 AUX12 CIRCUIT C4211 issue 3 SHEET 3 of 3

**ALLEN&HEATH**  
 Kernick Industrial Estate,  
 Penryn, Cornwall,  
 England, TR10 9LU  
 Tel: (44) (0) 1326 372070 Fax: (44) (0) 1326 365736

h  
g  
f  
e  
d  
c  
b  
a

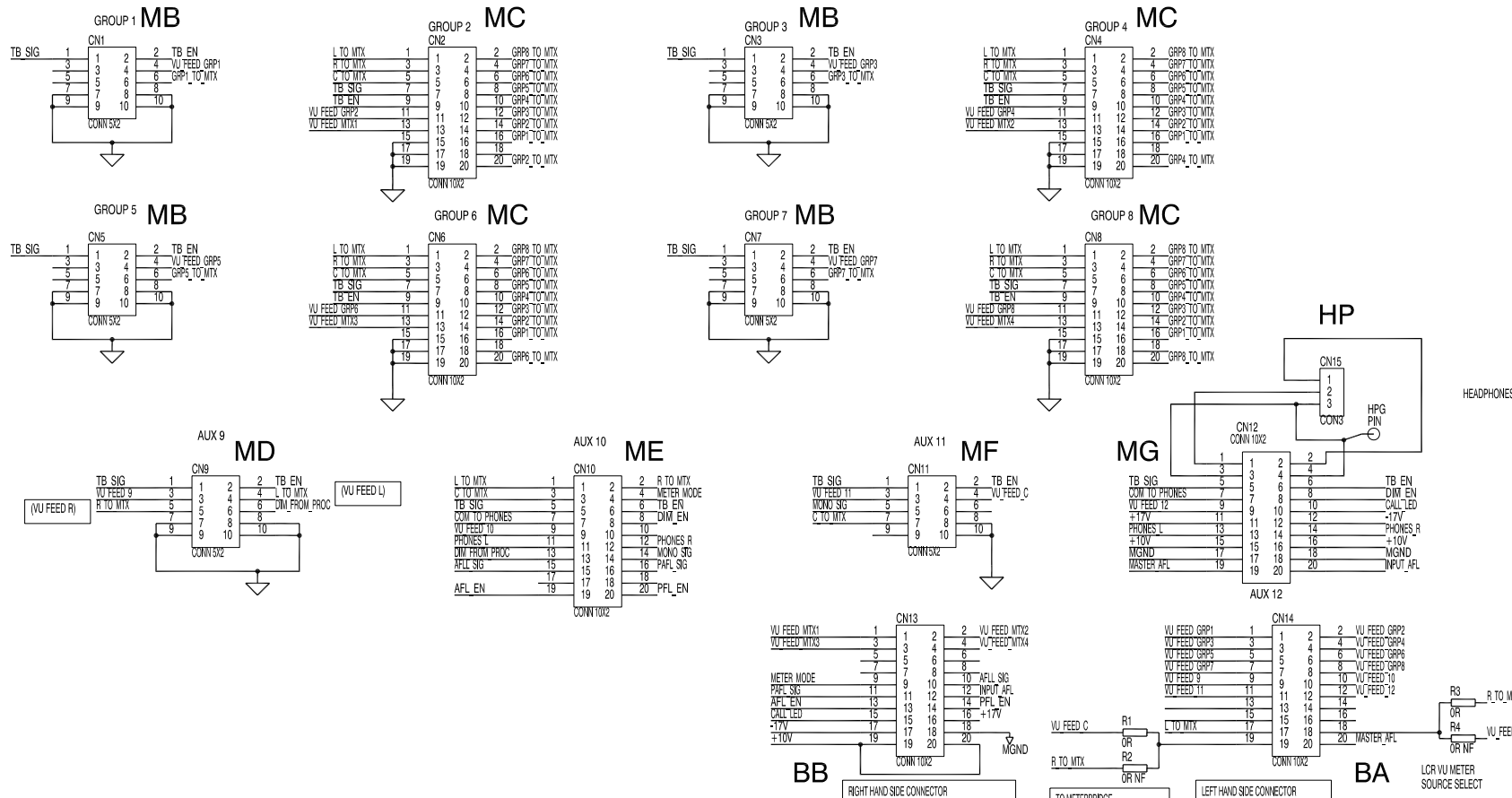
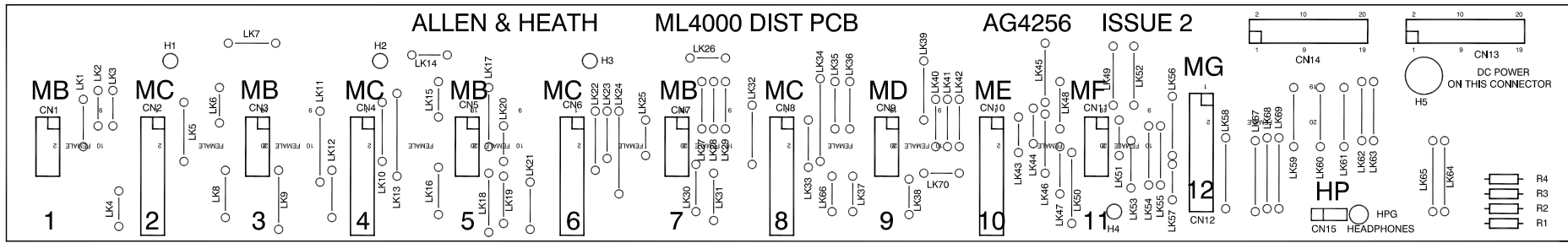

ISSUE	BY	DATE	ML4000 MASTER DISTRIBUTION CIRCUIT C4256 issue 2 SHEET 1 of 1		ALLEN & HEATH Kernick Industrial Estate, Penryn, Cornwall, England, TR10 9LU Tel: (44) (0) 1326 372070 Fax: (44) (0) 1326 365736



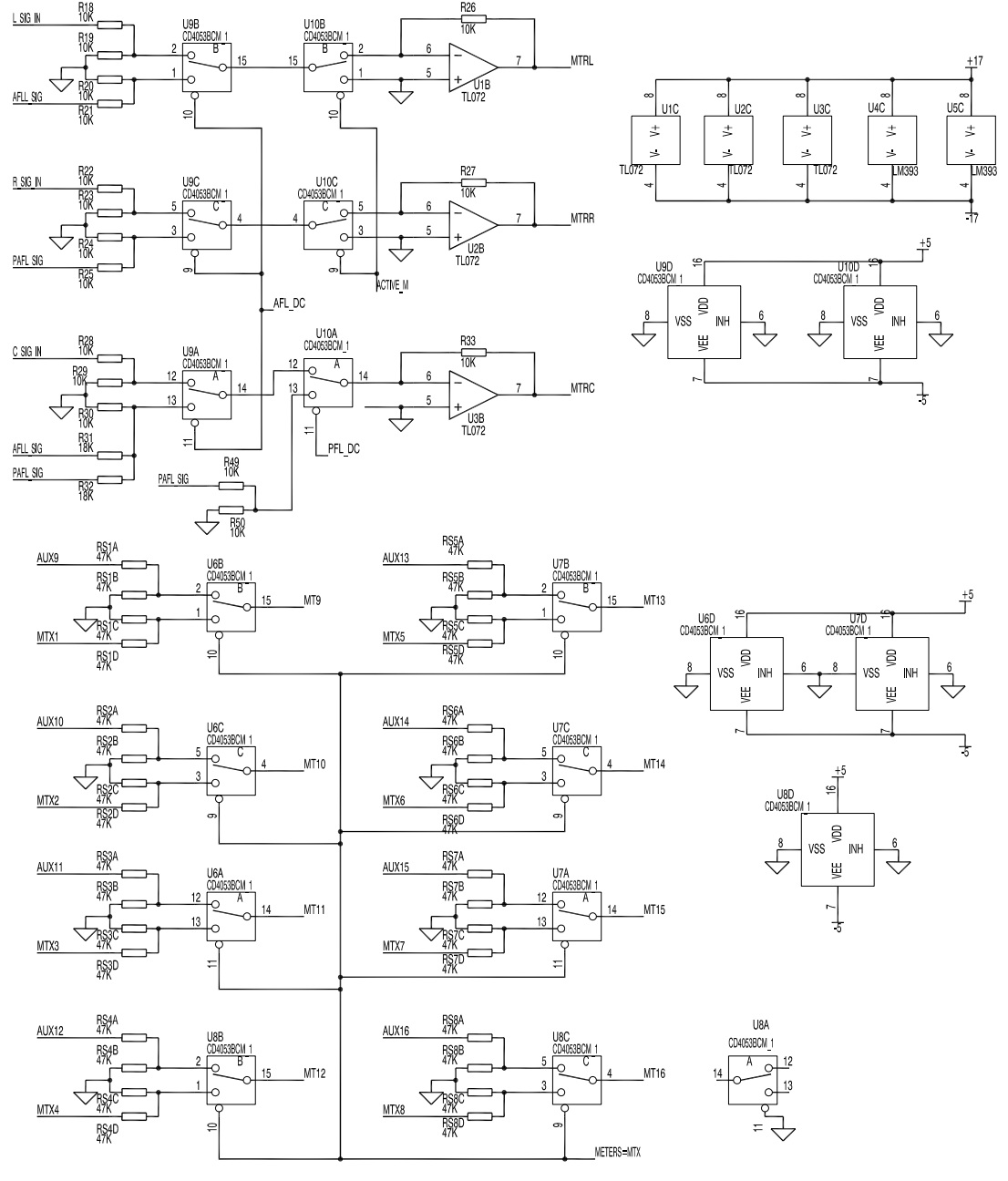
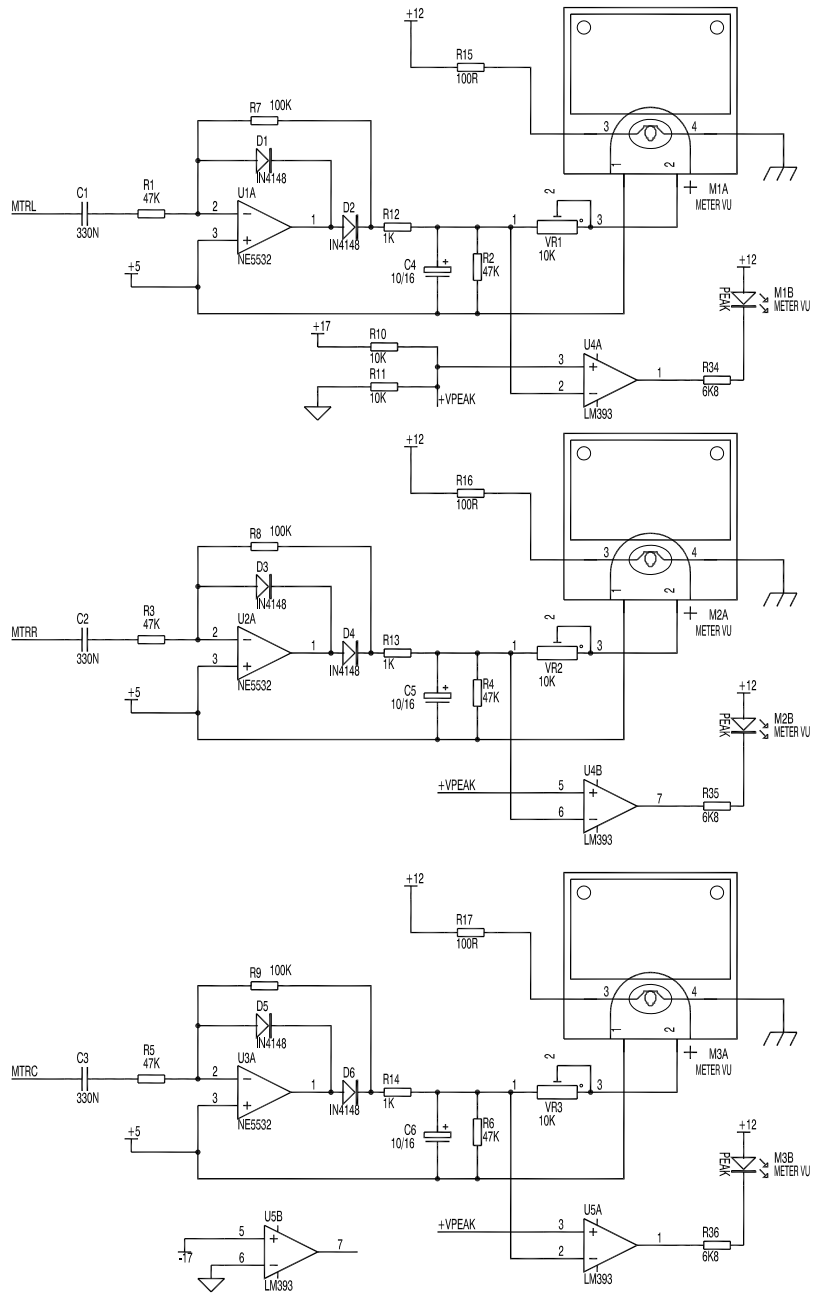

ISSUE	BY	DATE
A 1	JB JB	12/01/01 06/02/01

ML MASTER METERS CIRCUIT C4357 issue 1 SHEET 1 of 2

**ALLEN&HEATH**  
 Kennick Industrial Estate,  
 Penryn, Cornwall,  
 England, TR10 9LU  
 Tel: (44) (0) 1326 372070 Fax: (44) (0) 1326 365736

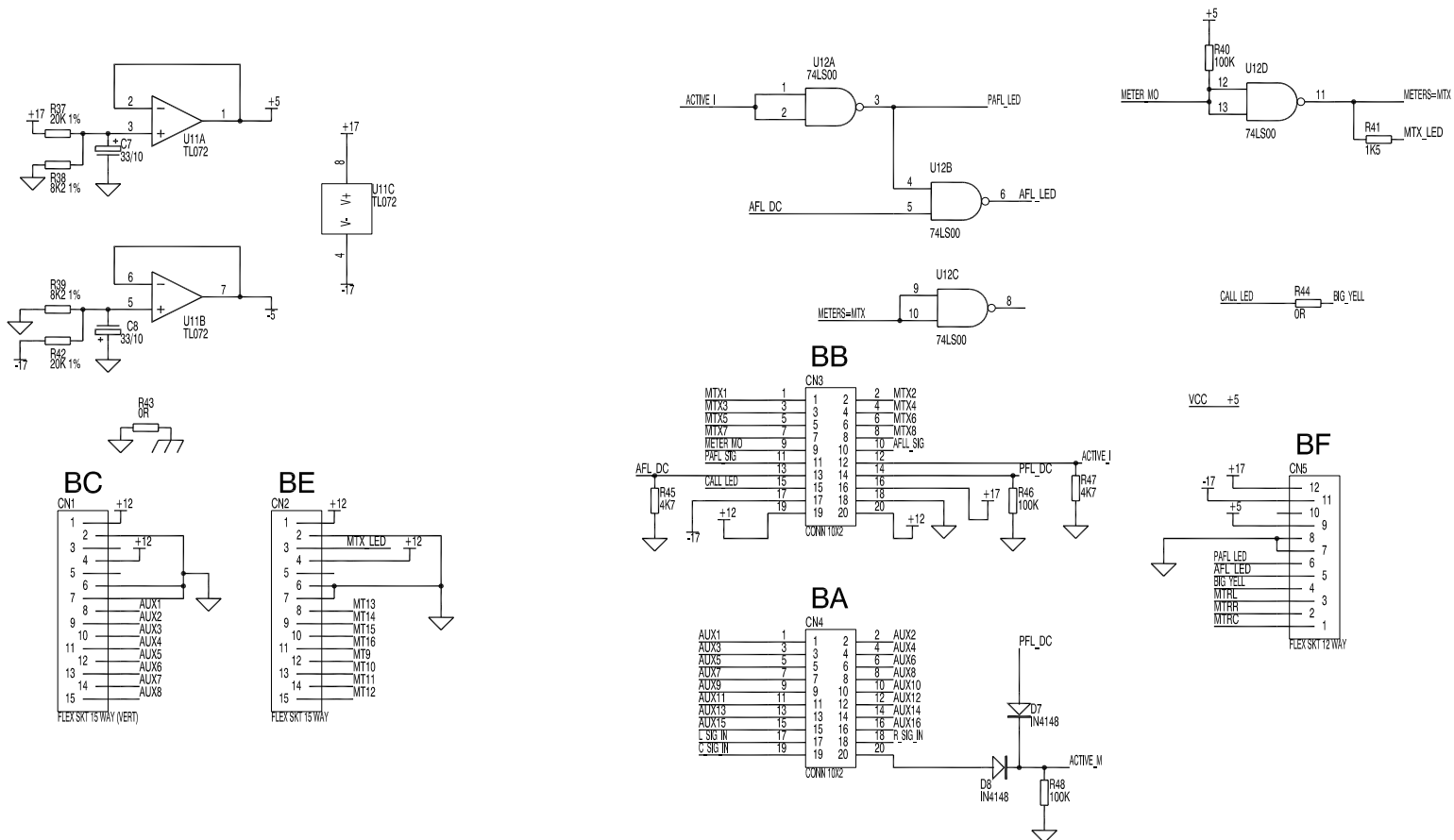
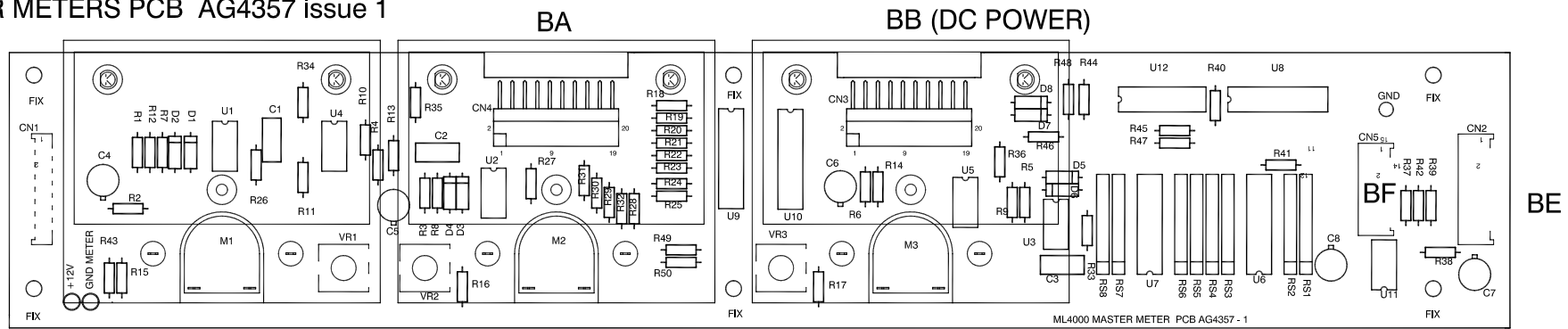

ISSUE	BY	DATE
A 1	JB JB	12/01/01 08/02/01

ML MASTER METERS CIRCUIT C4357 issue 1 SHEET 2 of 2

**ALLEN&HEATH**  
 Kennick Industrial Estate,  
 Penryn, Cornwall,  
 England, TR10 9LU  
 Tel: (44) (0) 1326 372070 Fax: (44) (0) 1326 365736

h  
g  
f  
e  
d  
c  
b  
a

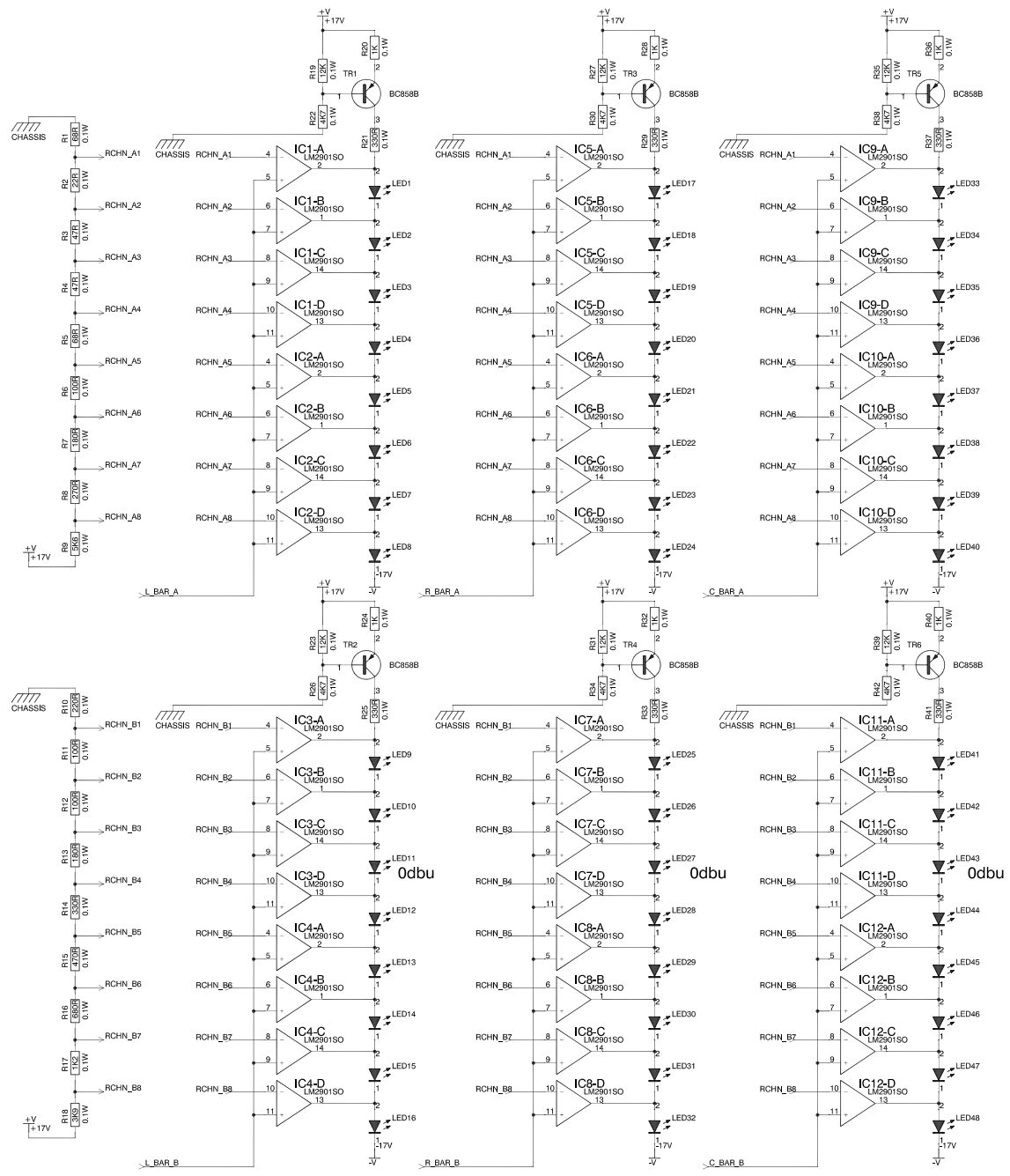
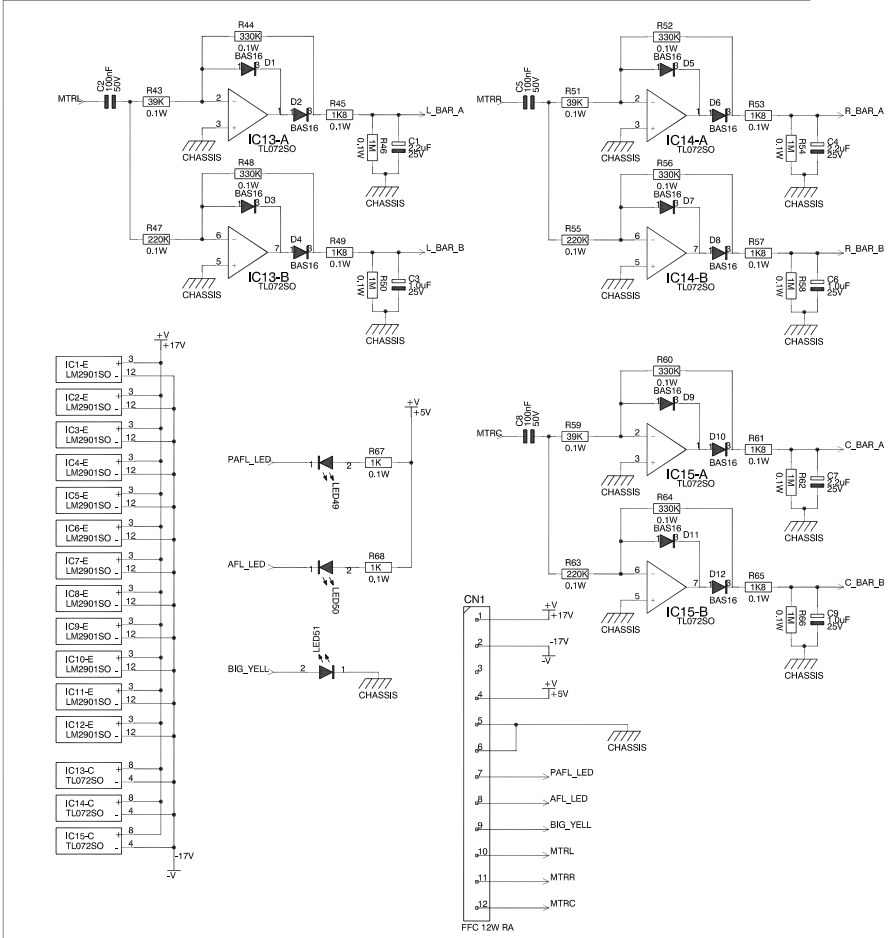
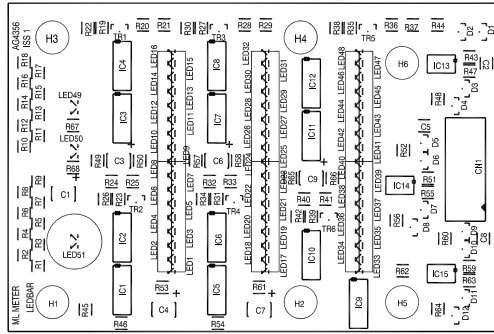

ML METER LEDBARS CIRCUIT C4356 issue 1 SHEET 1 of 1

ISS	REVISION	BY	DATE
A	ORIGIN PRODUCTION	AAT	03-01-01
1		AAT	08-02-01

**ALLEN & HEATH**  
 Kemick Industrial Estate,  
 Ferny, Cornwall,  
 England, TR10 5LU  
 Tel: (44) (0) 1326 372070 Fax: (44) (0) 1326 365736

ML METERS 1-8 PCB AG4358 issue 1

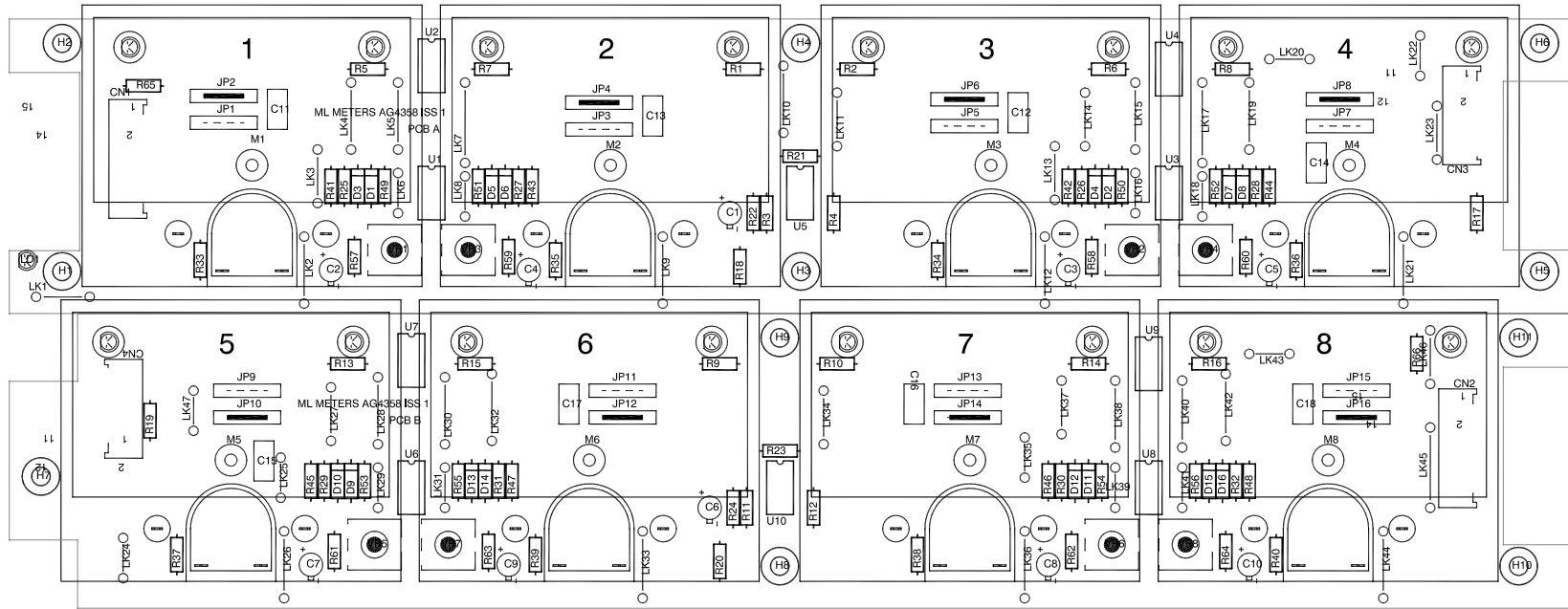

ML METERS 9-12 PCB AG4359 issue 1

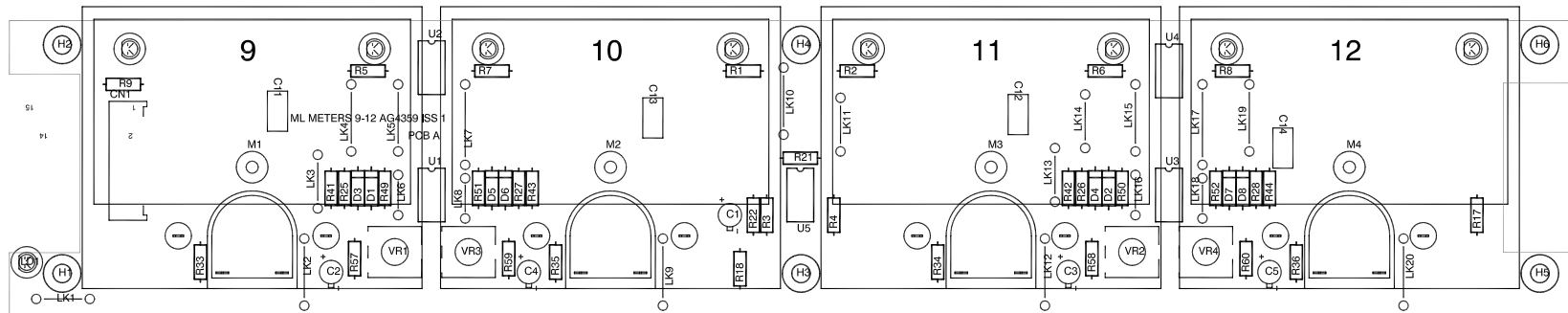

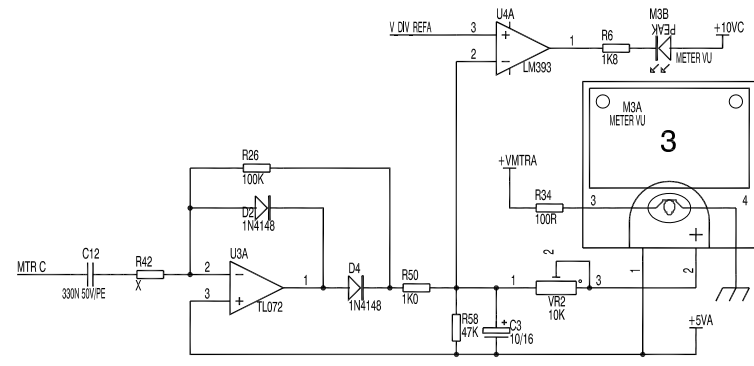
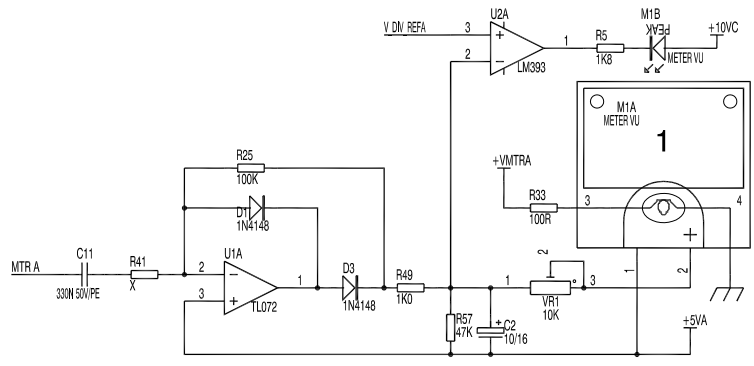
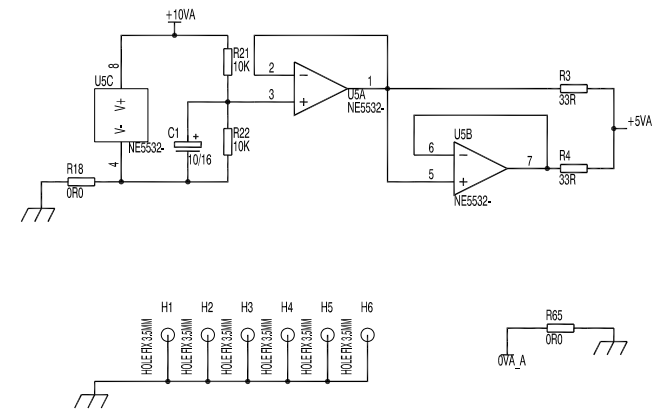
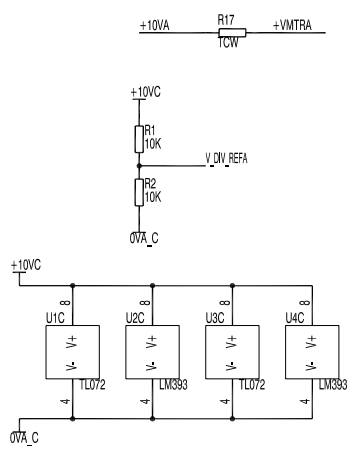
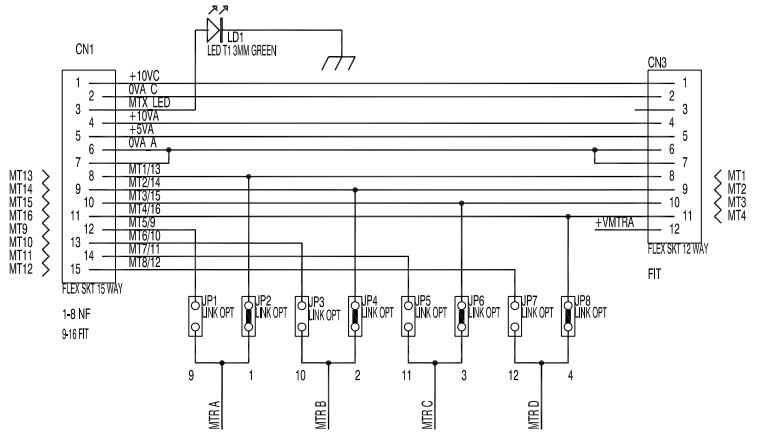

FOR METERS 1-8 R41, R42, R43, R44, R45, R46, R47, R48 X=47K

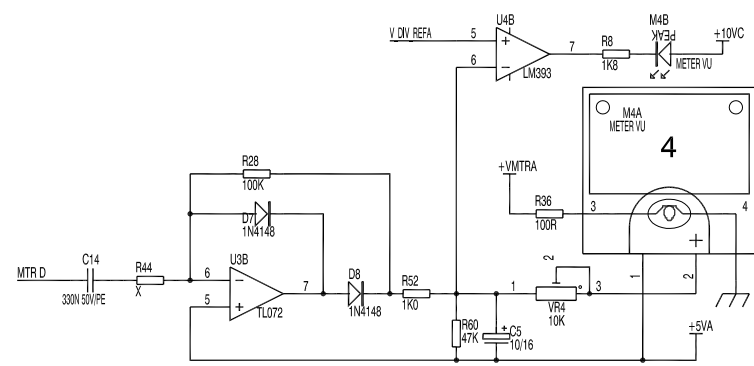
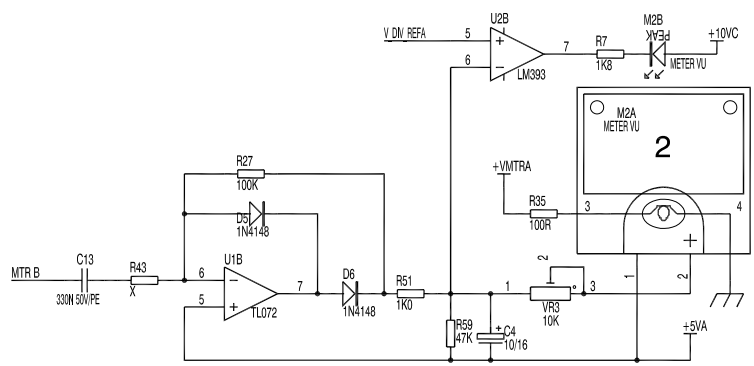

ISSUE	BY	DATE
A 1	AA1 AAT	08-21-01 01-02-01

ML METERS 1-8 CIRCUIT C4358 issue 1 SHEET 1 of 2 (POSITIONS 1-4)

**ALLEN&HEATH**  
 Kennick Industrial Estate,  
 Penryn, Cornwall,  
 England, TR10 9LU  
 Tel: (44) (0) 1326 372070 Fax: (44) (0) 1326 365736

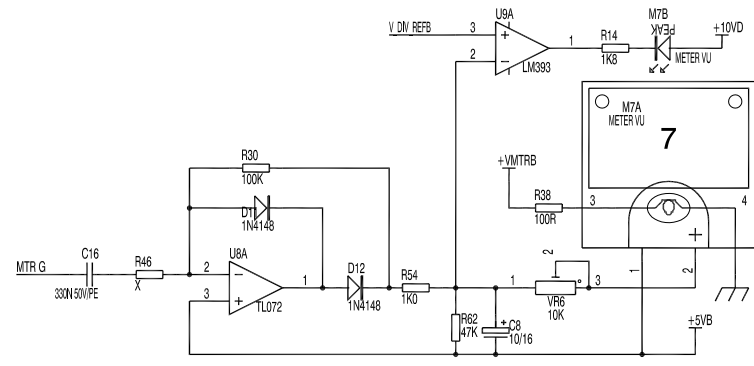
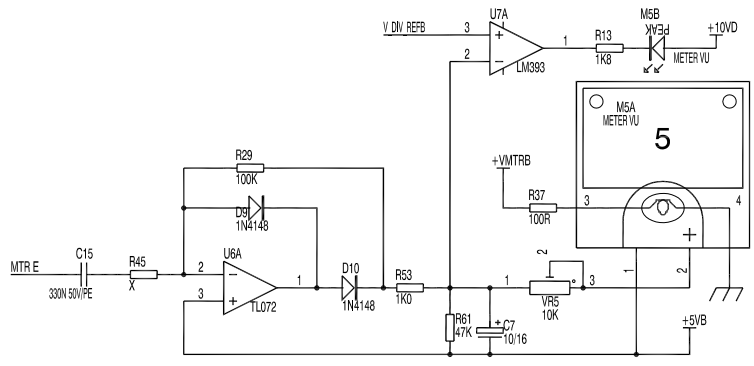
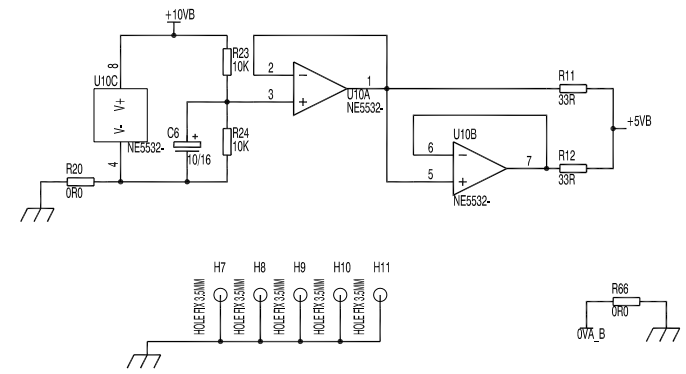
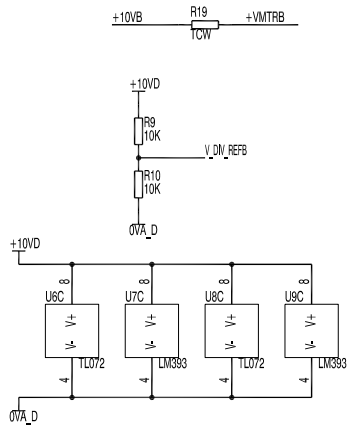
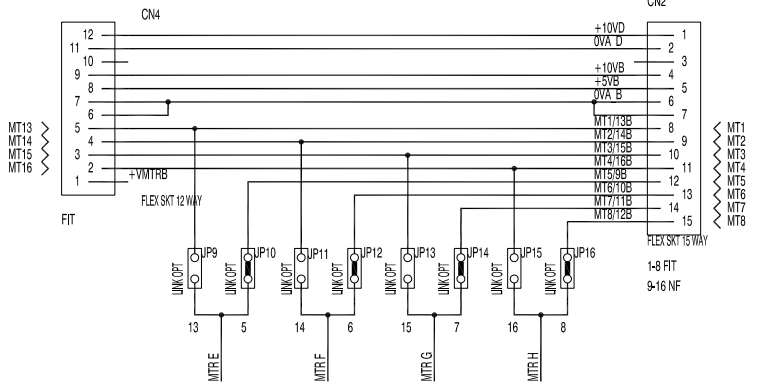

FOR METERS 1-8 R41,R42,R43,R44,R45,R46,R47,R48 X=47K

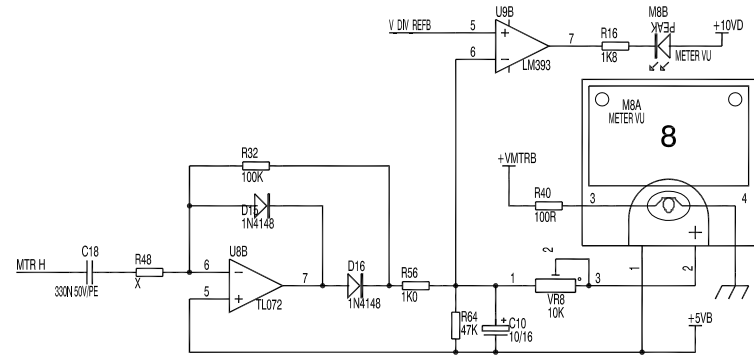
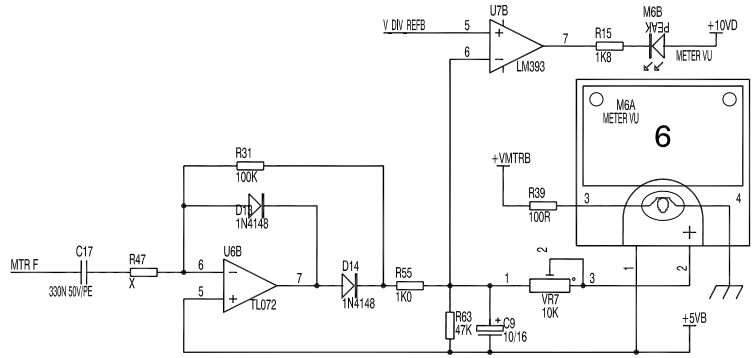

ISSUE	BY	DATE
A 1	AAT AAT	08-01-01 01-02-01

ML METERS 1-8 CIRCUIT C4358 issue 1 SHEET 2 of 2 (POSITIONS 5-8)

**ALLEN&HEATH**  
 Kernick Industrial Estate,  
 Penryn, Cornwall,  
 England, TR10 9LU  
 Tel: (44) (0) 1326 372070 Fax: (44) (0) 1326 365736

h  
g  
f  
e  
d  
c  
b  
a

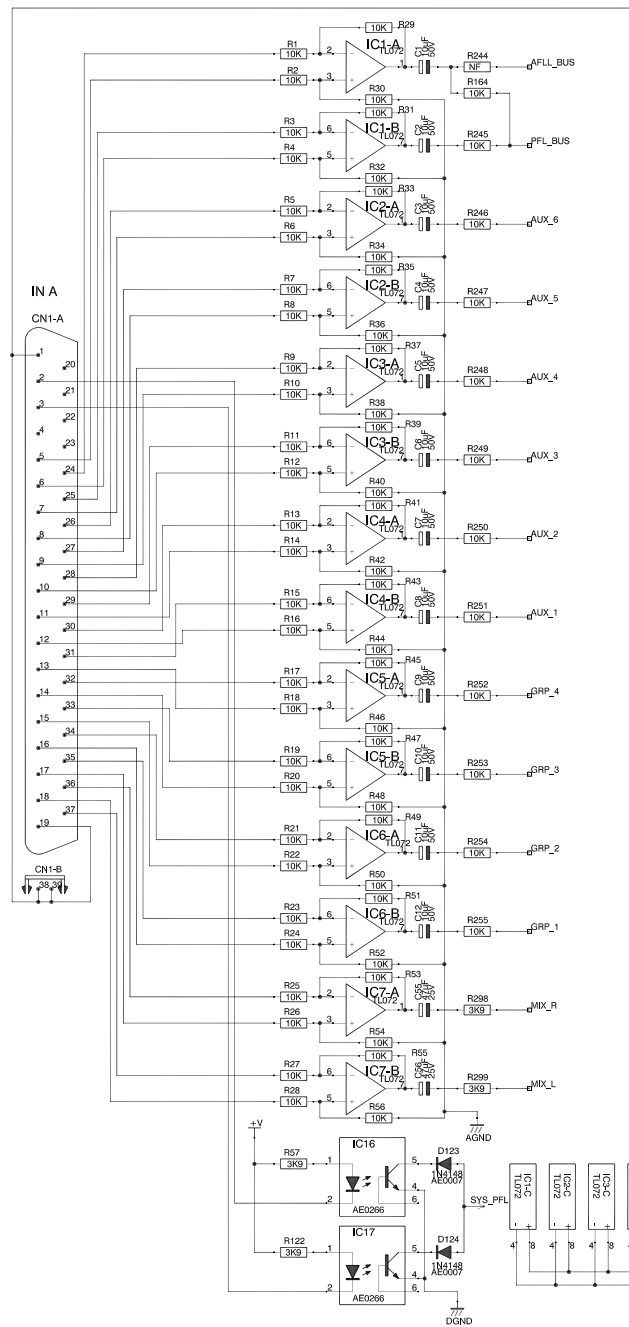

NOTE:- (CGND)CN6 PIN8 SHORTED TO (AGND)WITH TRACK STUB AT CN6P8  
(DGND)IC16, IC17 PINS4 SHORTED TO (AGND)WITH TRACK STUB AT IC16,17

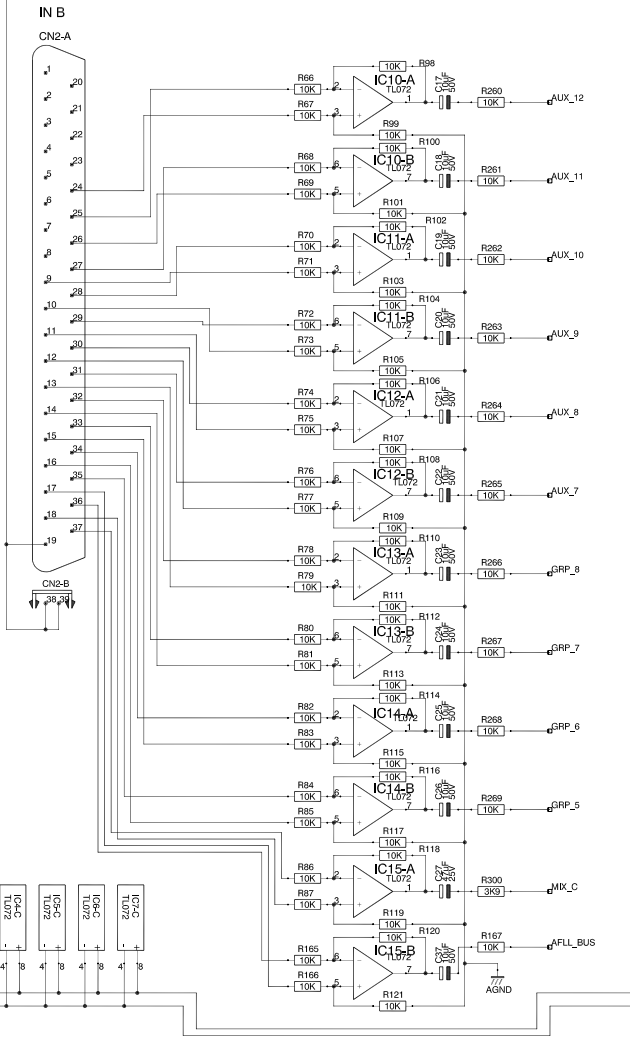

### ML4000 SYSLINK INPUT PCB AG4259 issue 1

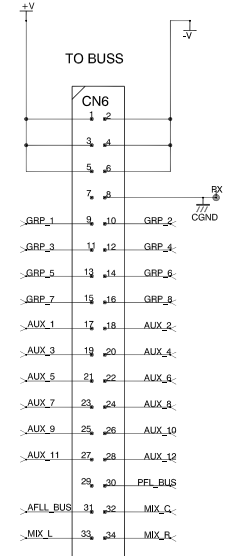
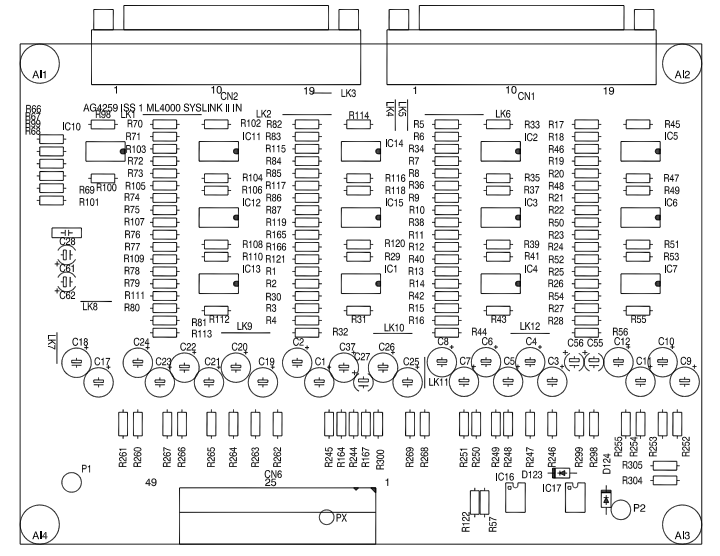

### ML4000 SYSLINK INPUT CIRCUIT C4259 issue 1 SHEET 1 of 1

ISS	REVISION	BY	DATE
A	ORIGIN	AAT	14/11/00
1		AAT	22/02/01

**ALLEN&HEATH**  
 Kemble Industrial Estate,  
 Pennon, Cornwall,  
 England TR10 5LU  
 Tel: (44) (0) 1326 372070 Fax: (44) (0) 1326 365736

h  
g  
f  
e  
d  
c  
b  
a

### ML5000 MIDI POWER PCB AG3884 issue 2

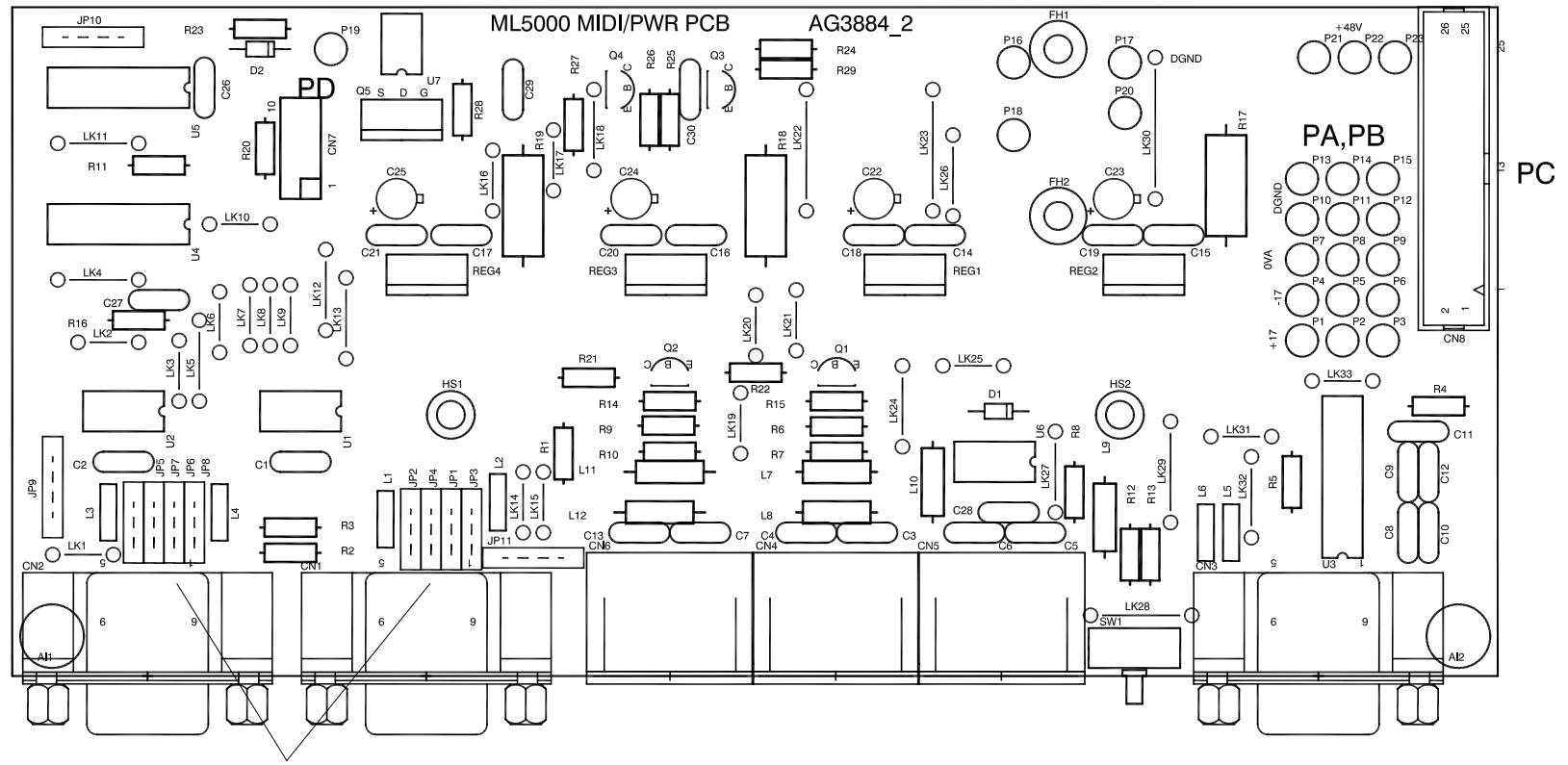

CONSOLE/SIDECAR ASSIGN LINKS



# CONSOLE/SIDECAR ASSIGN LINKS

M = FIT ON MAIN CONSOLE  
S = FIT ON SIDECAR

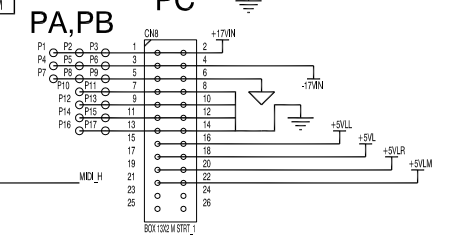
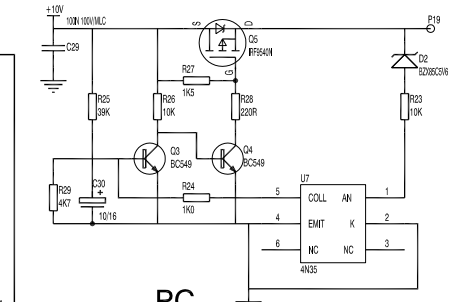
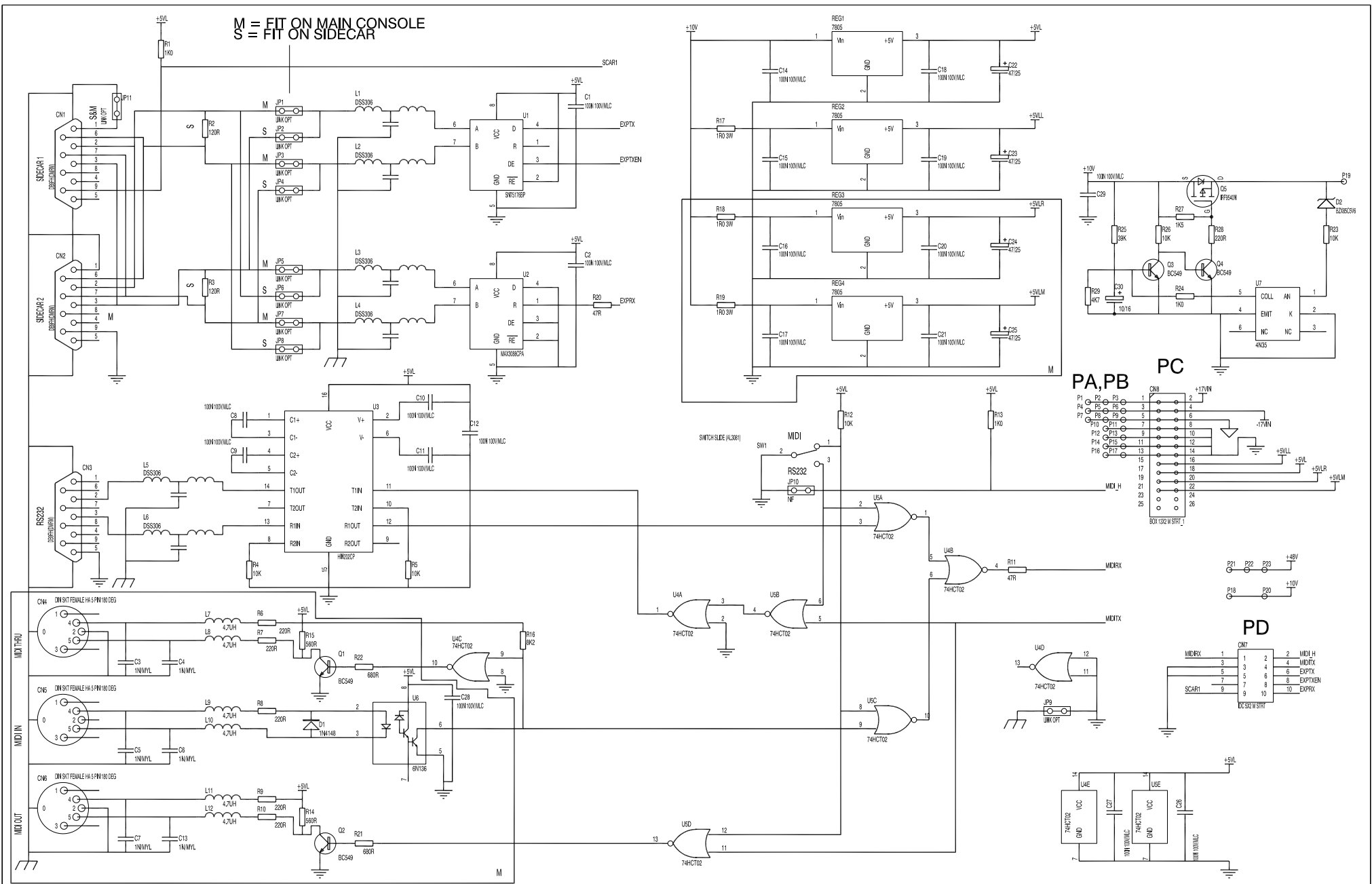

ISSUE	BY	DATE
2	AAT	24/6/01
2.1	AAT	30/10/01

ML5000 (ML4000) MIDI POWER CIRCUIT C3884 issue 2.1 SHEET 1 of 1

**ALLEN & HEATH**  
Kernick Industrial Estate,  
Bemmel, Cornwall  
England PL10 5LU  
Tel: (44) (0) 1326 372070 Fax:

h  
g  
f  
e  
d  
c  
b  
a

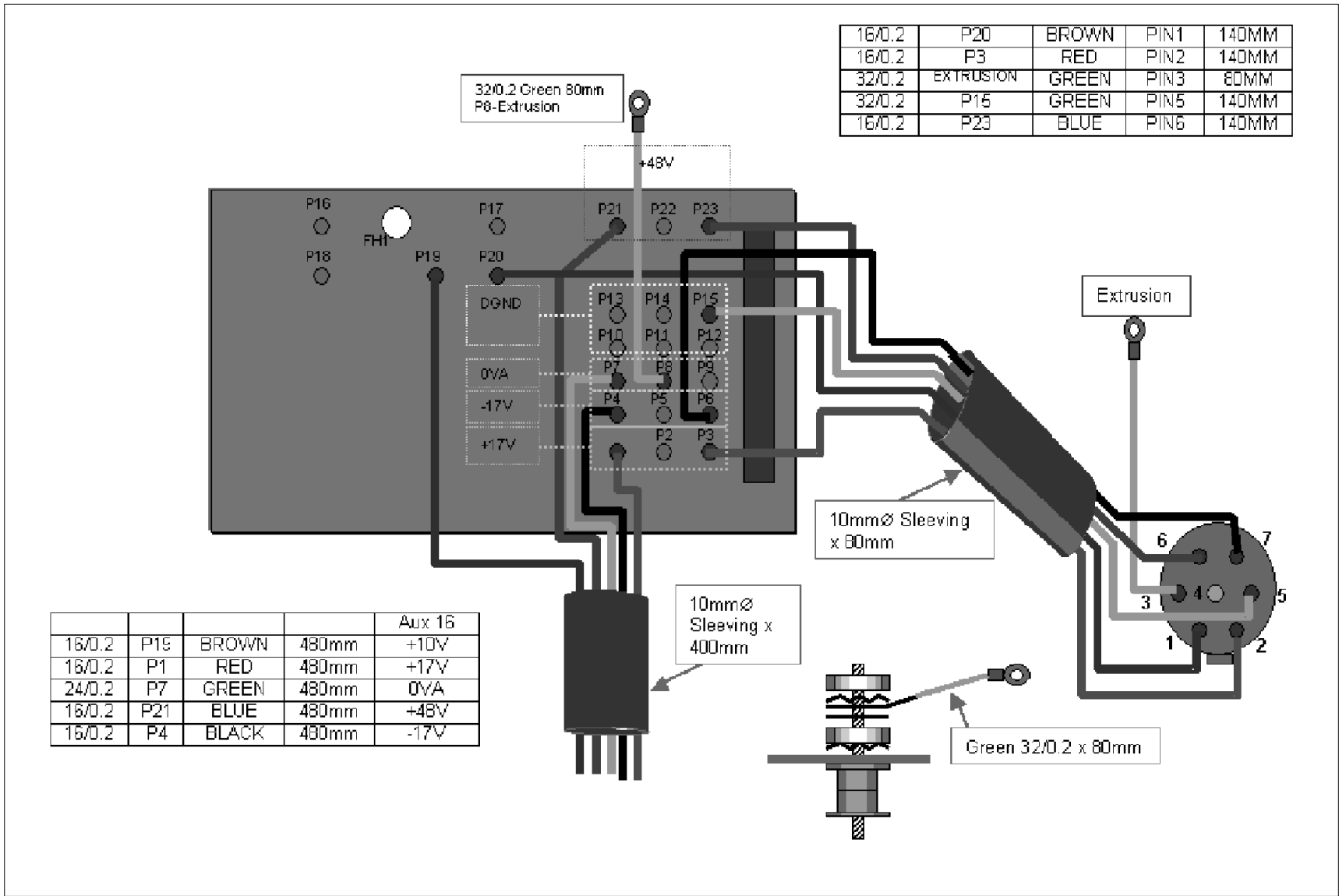

ML4000 DC POWER WIRING

ML5000 (ML4000) CPU PCB AG3718 issue 3

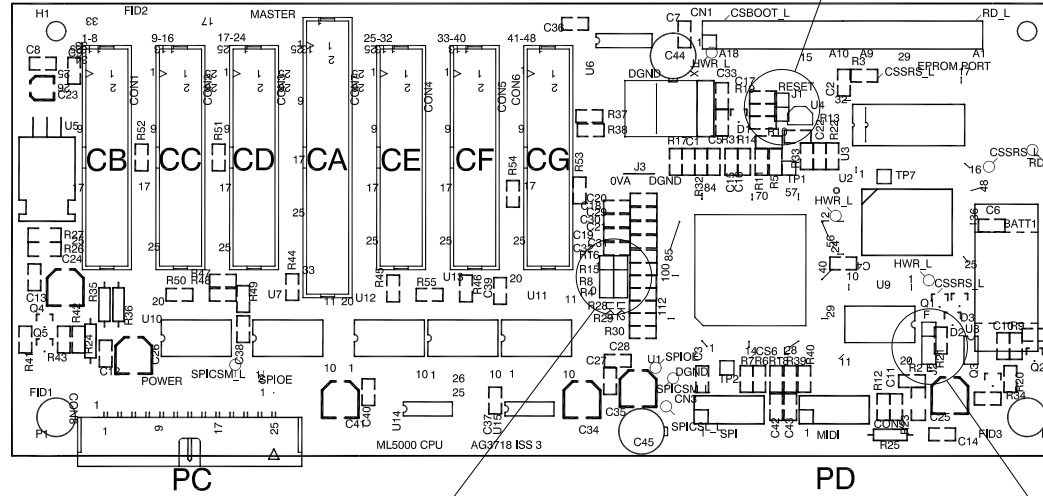

ML4000 SIDECAR



ML4000 CONSOLE



ML5000 SIDECAR



ML5000 CONSOLE



FLASH (NORMAL)



EPROM (BOOT LOAD)

ASSIGN LINKS ACCORDING TO CONSOLE TYPE

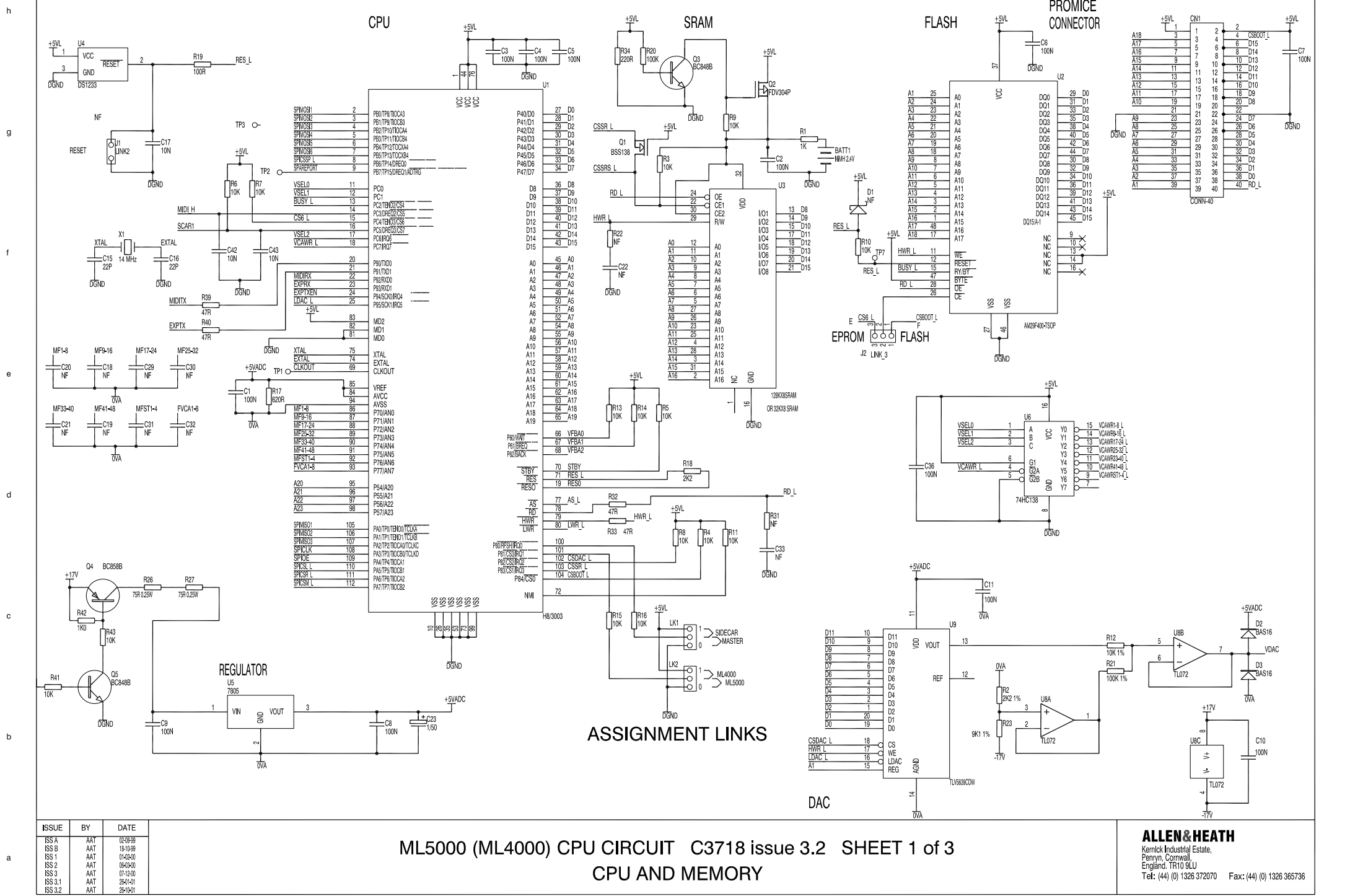

ISSUE	BY	DATE
ISS A	AAT	02/98
ISS B	AAT	18-10-98
ISS 1	AAT	04-02-00
ISS 2	AAT	06-03-00
ISS 3	AAT	07-12-00
ISS 3.1	AAT	26-01-01
ISS 3.2	AAT	28-10-01

**ML5000 (ML4000) CPU CIRCUIT C3718 issue 3.2 SHEET 1 of 3**  
**CPU AND MEMORY**

**ALLEN&HEATH**  
 Kernick Industrial Estate,  
 Pennyn, Cornwall,  
 England. TR10 9LU  
 Tel: (44) (0) 1326 372070 Fax: (44) (0) 1326 365736

h  
g  
f  
e  
d  
c  
b  
a

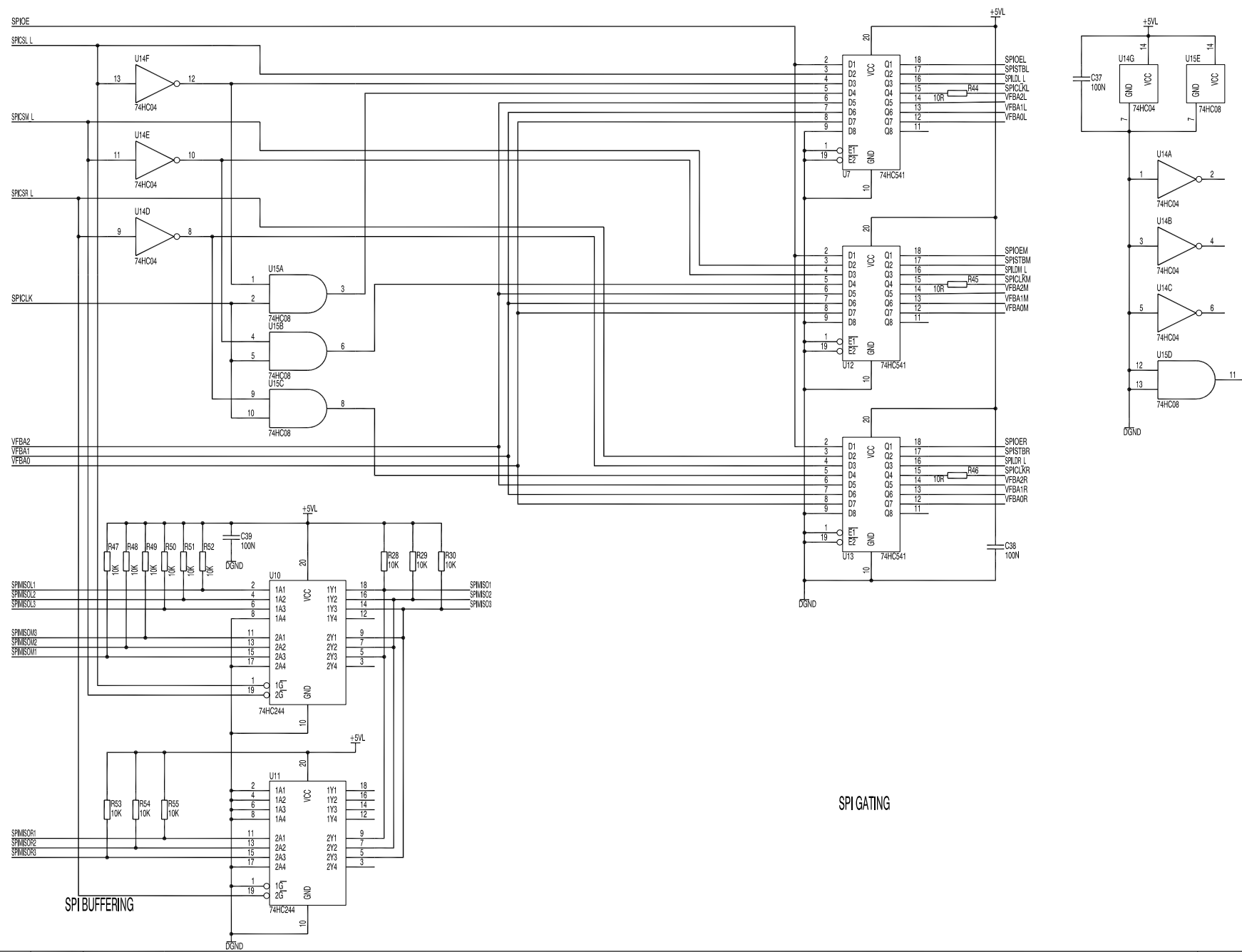

ML5000 (ML4000) CPU CIRCUIT C3718 issue 3.2 SHEET 2 of 3  
SPI AND BUFFERING

**ALLEN&HEATH**  
Kernick Industrial Estate,  
Penryn, Cornwall,  
England, TR10 9LU  
Tel: (44) (0) 1326 372070 Fax: (44) (0) 1326 365736

ISSUE	BY	DATE
ISS A	AAT	02/08/99
ISS B	AAT	18/10/99
ISS 1	AAT	01/02/00
ISS 2	AAT	06/03/00
ISS 3	AAT	07/12/00
ISS 3.1	AAT	26/01/01
ISS 3.2	AAT	28/10/01



h  
g  
f  
e  
d  
c  
b  
a

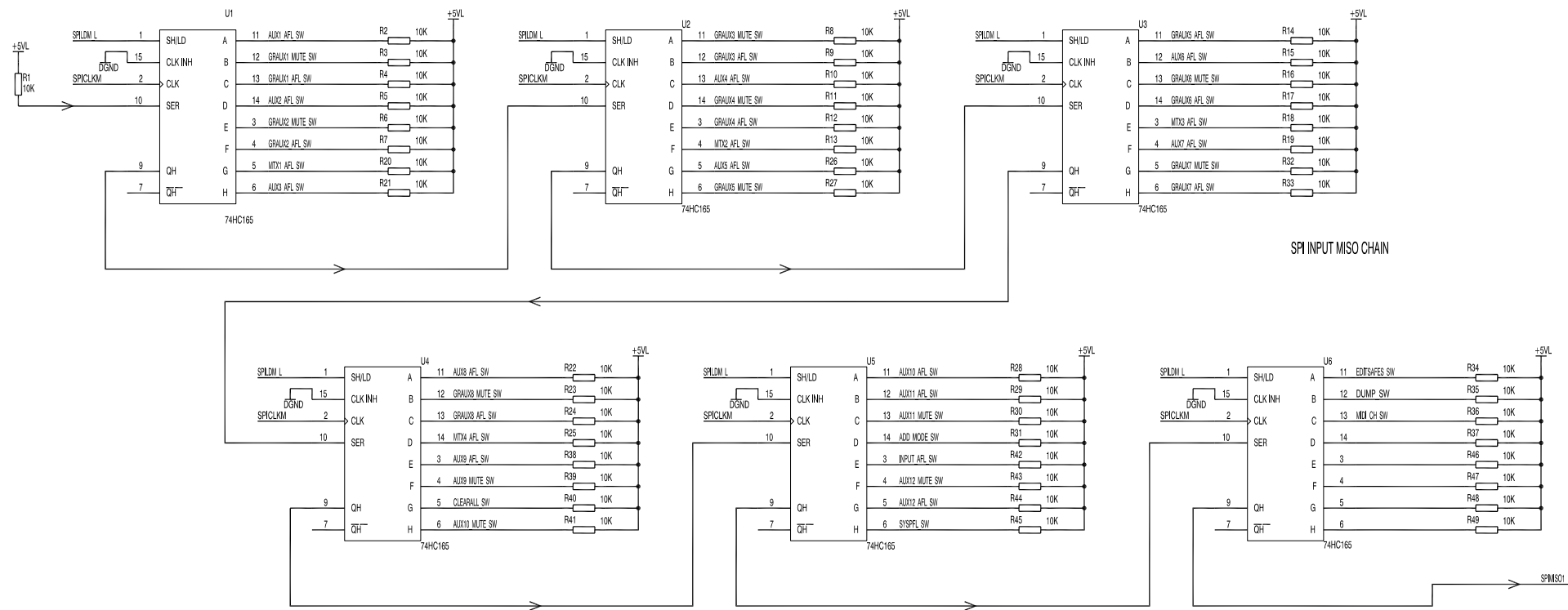
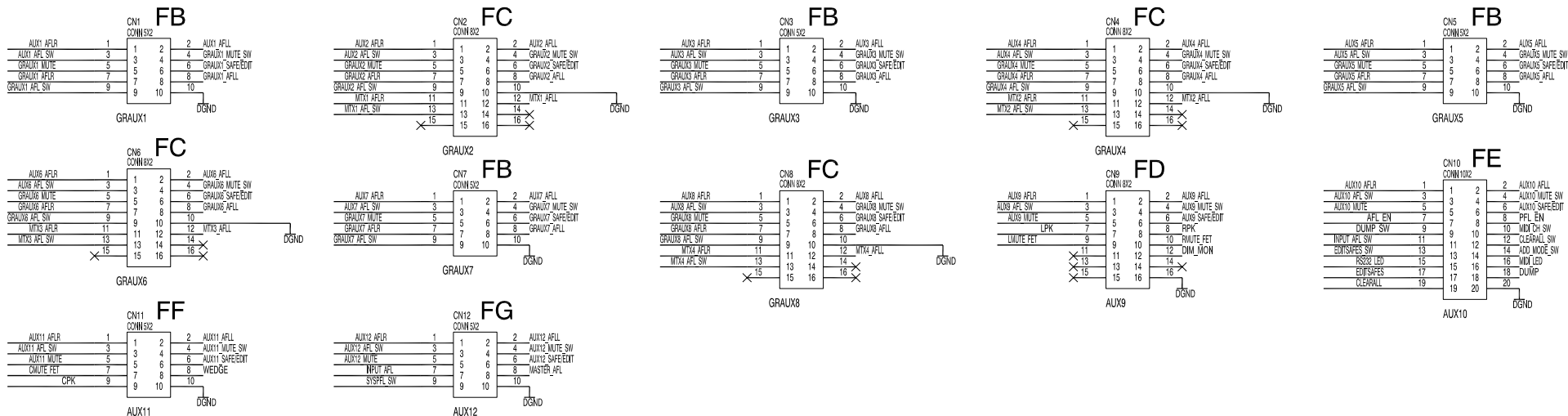

ISSUE	BY	DATE
A	DLP	17/8/00
1	AAT	16/11/00
2	JB	7/3/01

ML4000 GRAUX SLAVE CIRCUIT C4215 issue 2 SHEET 1 of 2

**ALLEN&HEATH**  
 Kennick Industrial Estate,  
 Penryn, Cornwall,  
 England, TR10 9LU  
 Tel: (44) (0) 1326 372070 Fax: (44) (0) 1326 365736

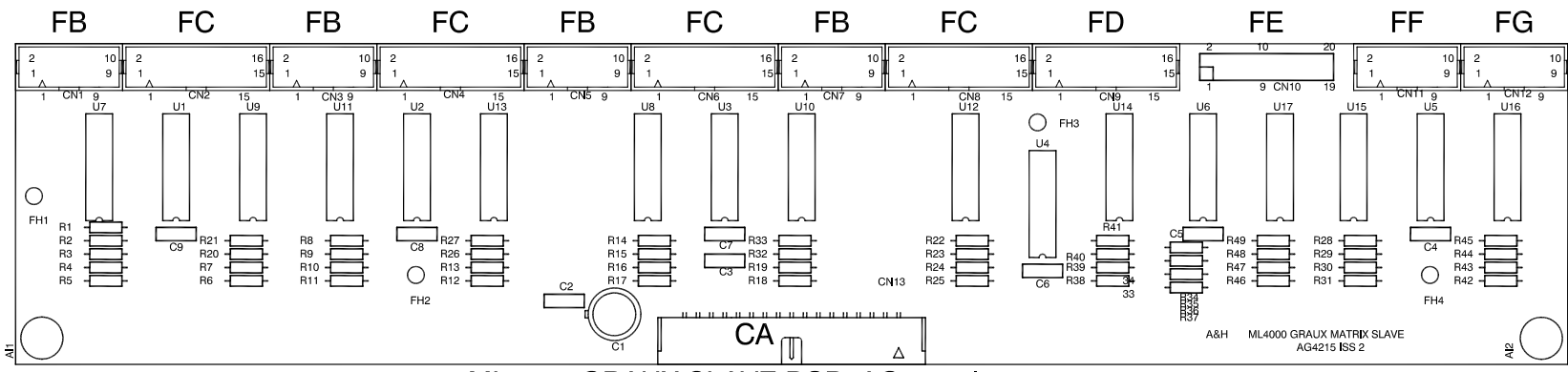

ML4000 GRAUX SLAVE PCB AG4215 issue 2

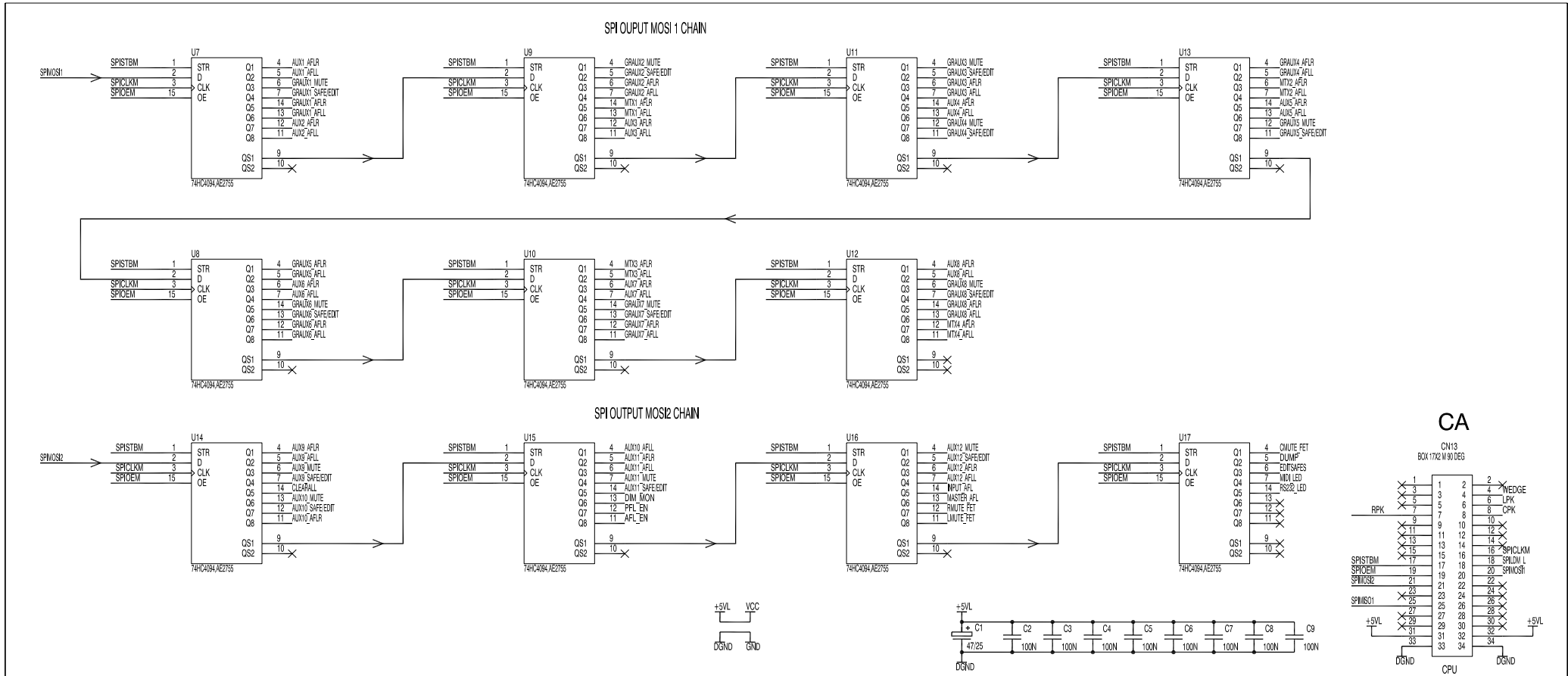

ISSUE	BY	DATE
A	DLP	17/8/00
1	AAT	15/11/00
2	JB	7/3/01

ML4000 GRAUX SLAVE CIRCUIT C4215 issue 2 SHEET 2 of 2

**ALLEN&HEATH**  
 Kennick Industrial Estate,  
 Penryn, Cornwall,  
 England, TR10 9LU  
 Tel: (44) (0) 1326 372070 Fax: (44) (0) 1326 365736



h  
g  
f  
e  
d  
c  
b  
a

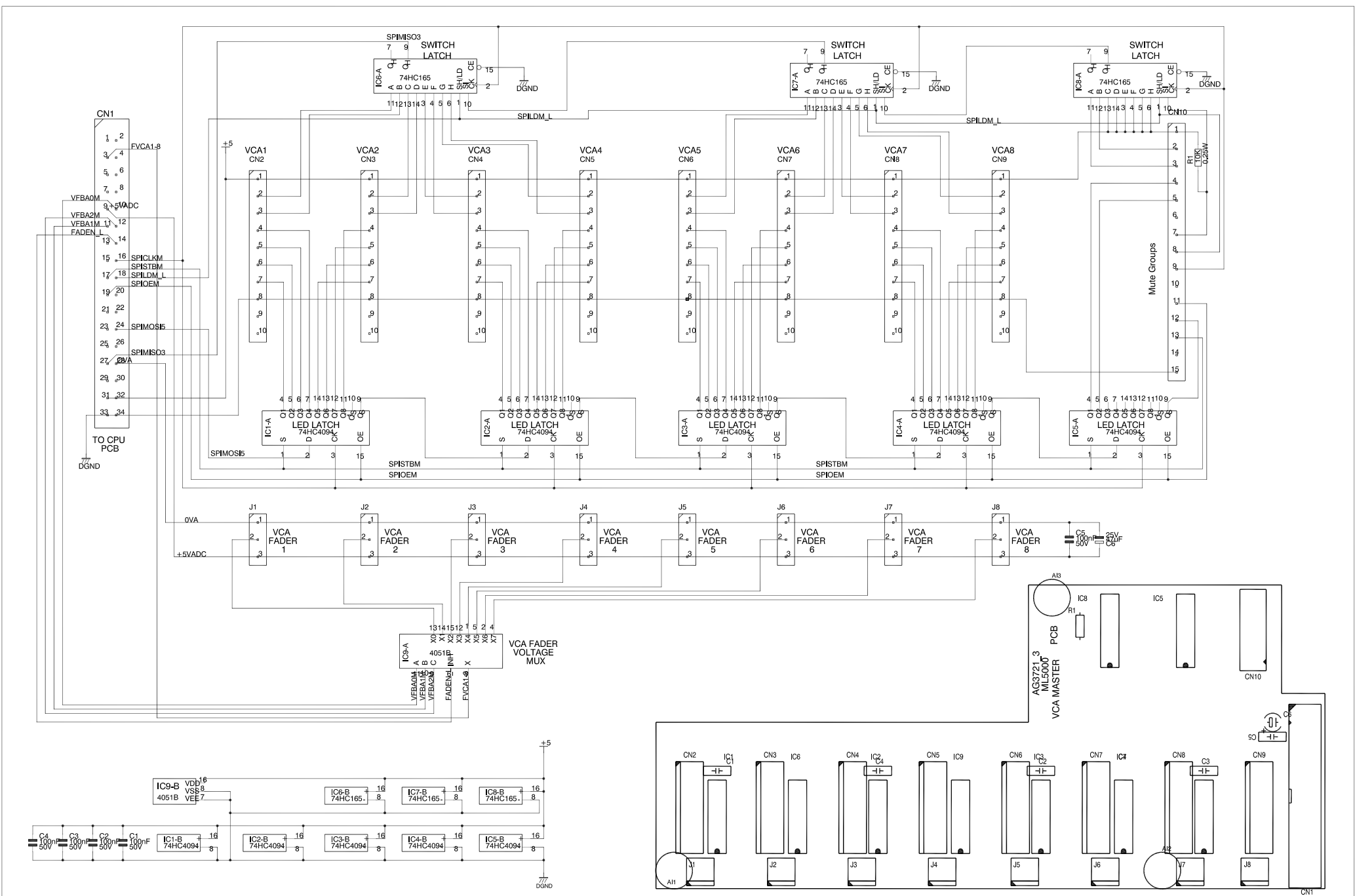

ISS	REVISION	BY	DATE
A	ORIGIN	GMR	11/18/99
B	IDC CHG + OTHER	AAT	13/10/99
1	GROUND PLANE ADDED TO PCB MOUNT	AAT	03-12-99
2	FADER CONN WIRING	AAT	28-02-00
3	PROFILE CHANGE FOR ML4000 FIT	AAT	20-11-00

## ML4000 VCA MASTER SLAVE CIRCUIT C3721 issue 3 SHEET 1 of 1

**ALLEN & HEATH**  
 Kemble Industrial Estate,  
 Perryng, Cornwall,  
 England, TR10 9LU  
 Tel: (44) (0) 1326 372070 Fax: (44) (0) 1326 365736

h  
g  
f  
e  
d  
c  
b  
a

### ML4000 LRC STEREO SLAVE PCB AG4207 issue 2

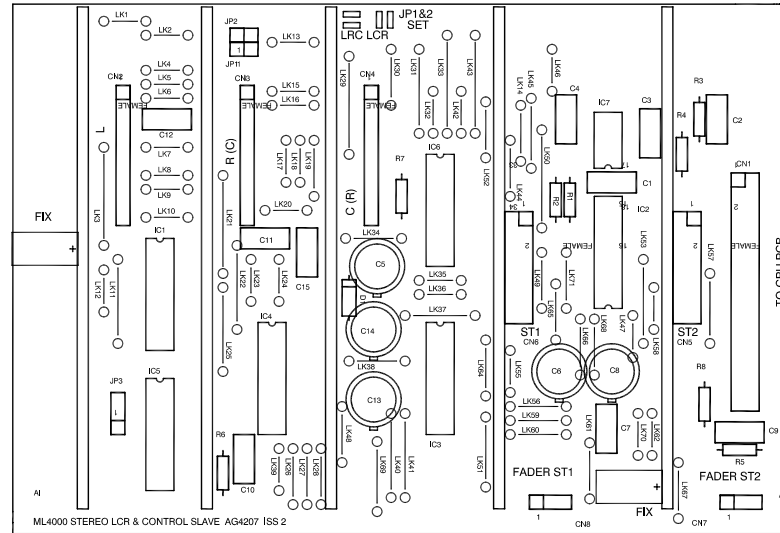

h  
g  
f  
e  
d  
c  
b  
a

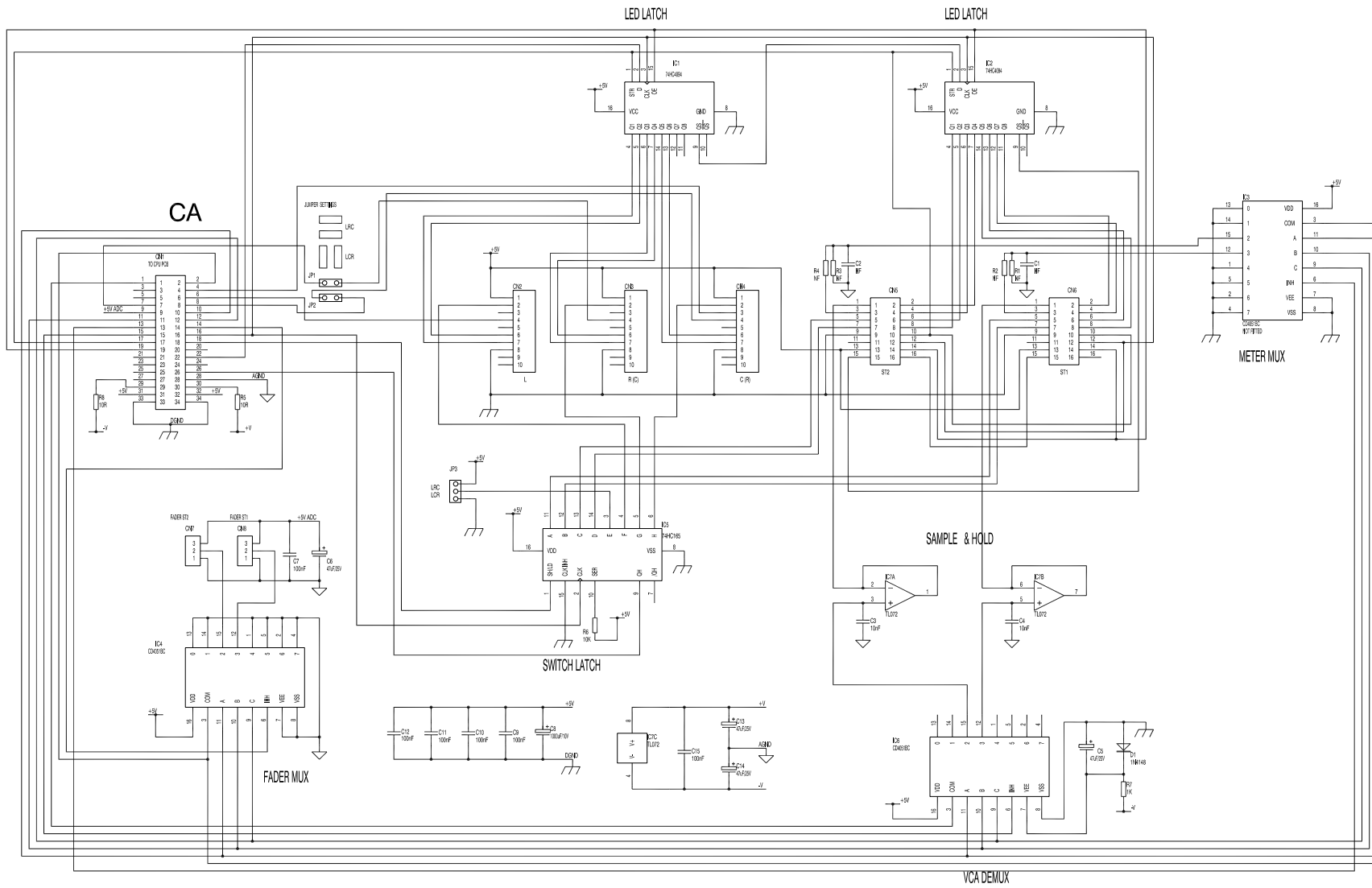

ISSUE	BY	DATE
A	JB	24/1/00
1	JB	16/1/00
1.1	JB	28/1/00
2	JB	12/3/01

ML4000 LRC STEREO SLAVE CIRCUIT C4207 issue 2 SHEET 1 of 1

**ALLEN & HEATH**  
 Kemick Industrial Estate,  
 Fernhill, Cornwall,  
 England, TR10 3LU  
 Tel: (44) (0) 1326 372070 Fax: (44) (0) 1326 365736

h  
g  
f  
e  
d  
c  
b  
a

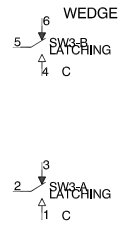
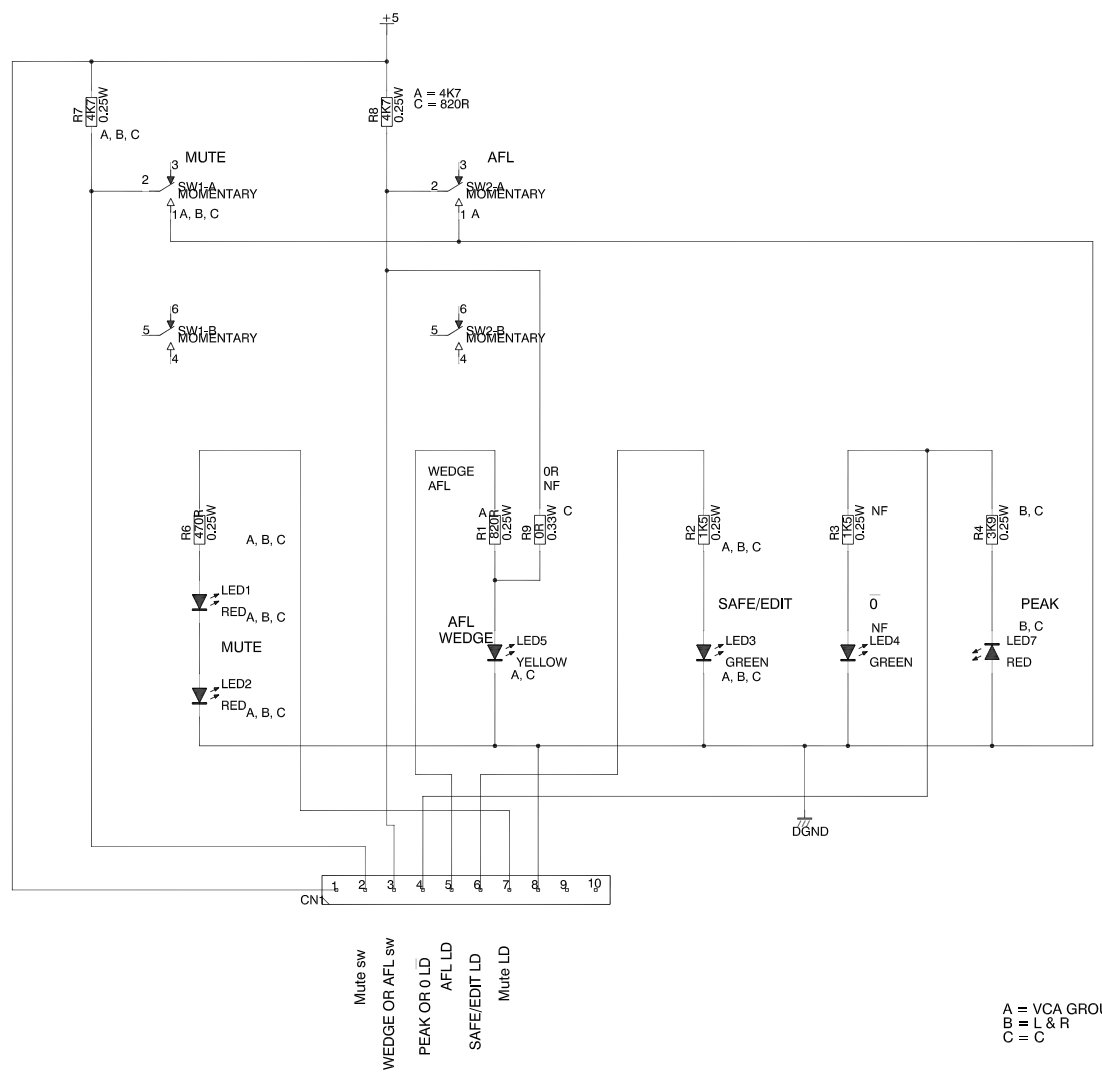

ML4000 MASTER FADER PCB AG3722 issue 3.1

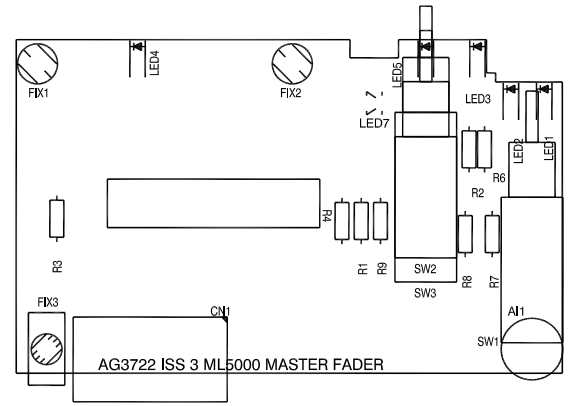

A = VCA GROUP 1-8  
B = L & R  
C = C

ML4000 MASTER FADER CIRCUIT C3722 issue 3 SHEET 1 of 1

ISS	REVISION	BY	DATE
1	ORIGIN SWAP PINS 4,7 ON CN1 GROUND PLANE ADDED (DGND) TO MOUNTINGS	GMR AAT	30/7/99 04-11-99 02-11-99
2	VALUES / ANNOTATION	AAT	28-02-00
3	FIXING HOLE ADJUSTMENT	AAT	30-05-00

**ALLEN & HEATH**  
 Kemtek Industrial Estate,  
 Ferryhill, Co. Durham,  
 England, TR10 9LU  
 Tel: (44) (0) 1326 372070 Fax: (44) (0) 1326 365736

ML4000 MUTE GROUP PCB AG3723 issue 2

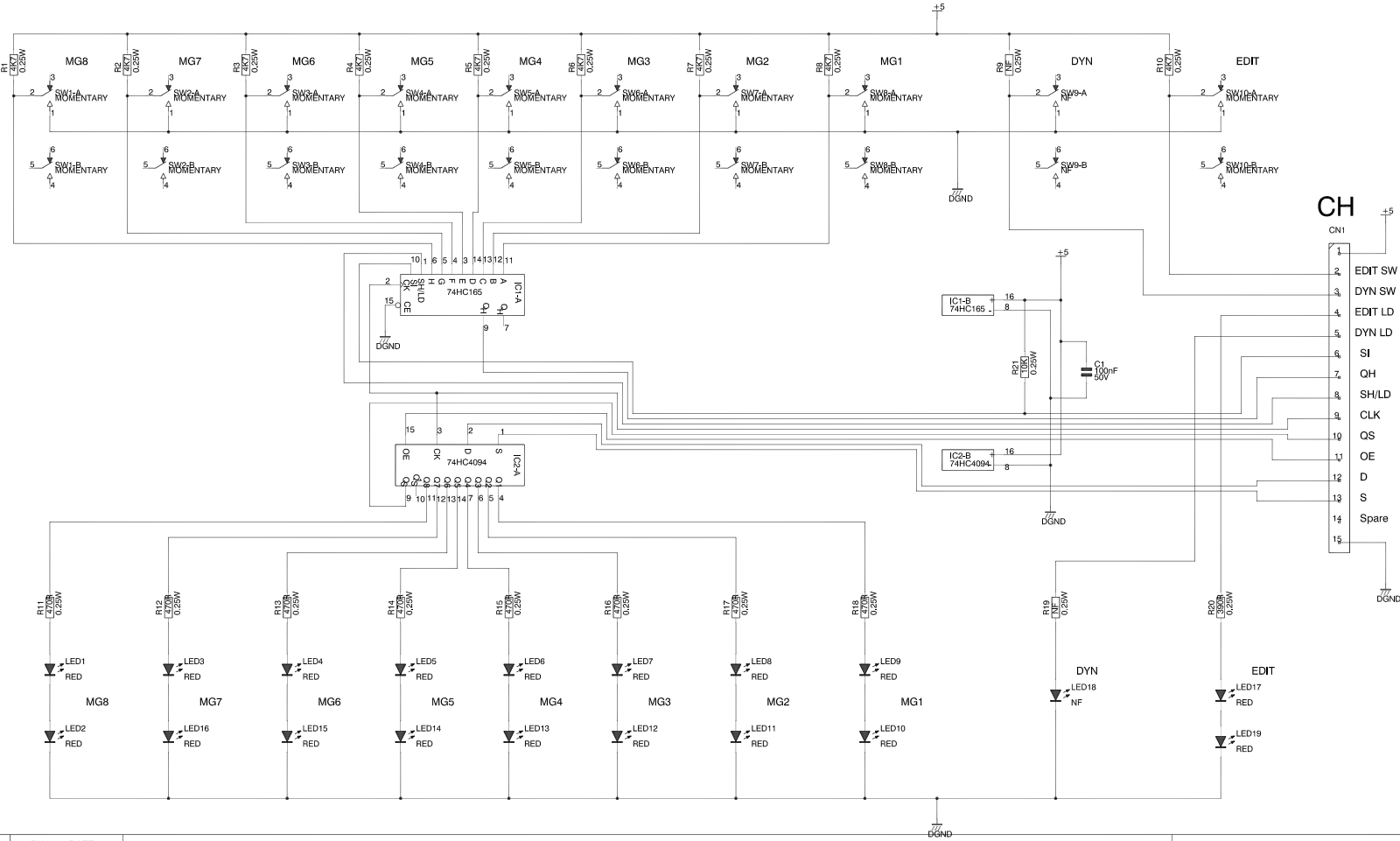
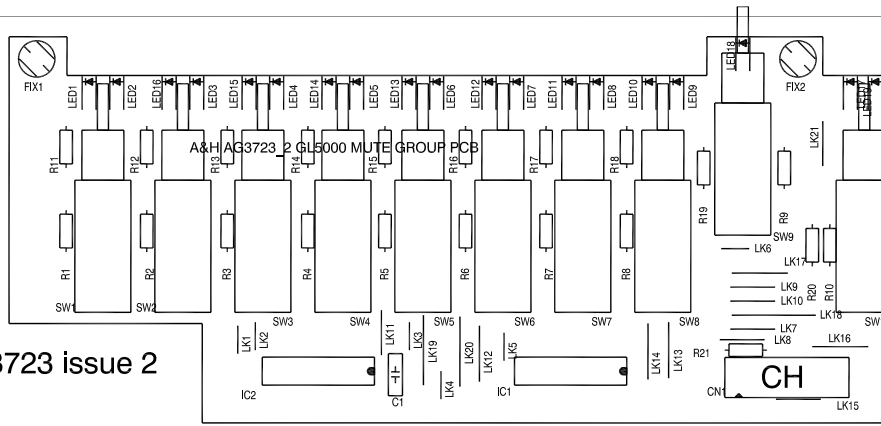

ML4000 MUTE GROUP CIRCUIT C3723 issue 2 SHEET 1 of 1

ISS	REVISION	BY	DATE
A	ORIGIN	GMR	30/7/99
1	GROUNDING PLANE ADDED TO MOUNTINGS	AAT	02-12-99
2	VALUE CHANGES & (LED HEIGHT)	AAT	22-02-00

**ALLEN & HEATH**  
 Kemlock Industrial Estate,  
 Ferryhill, Cornwall,  
 England, TR10 5LU  
 Tel: (44) (0) 1326 372070 Fax: (44) (0) 1326 365736

ML4000 MONO FADER SLAVE PCB AG3714 issue 1

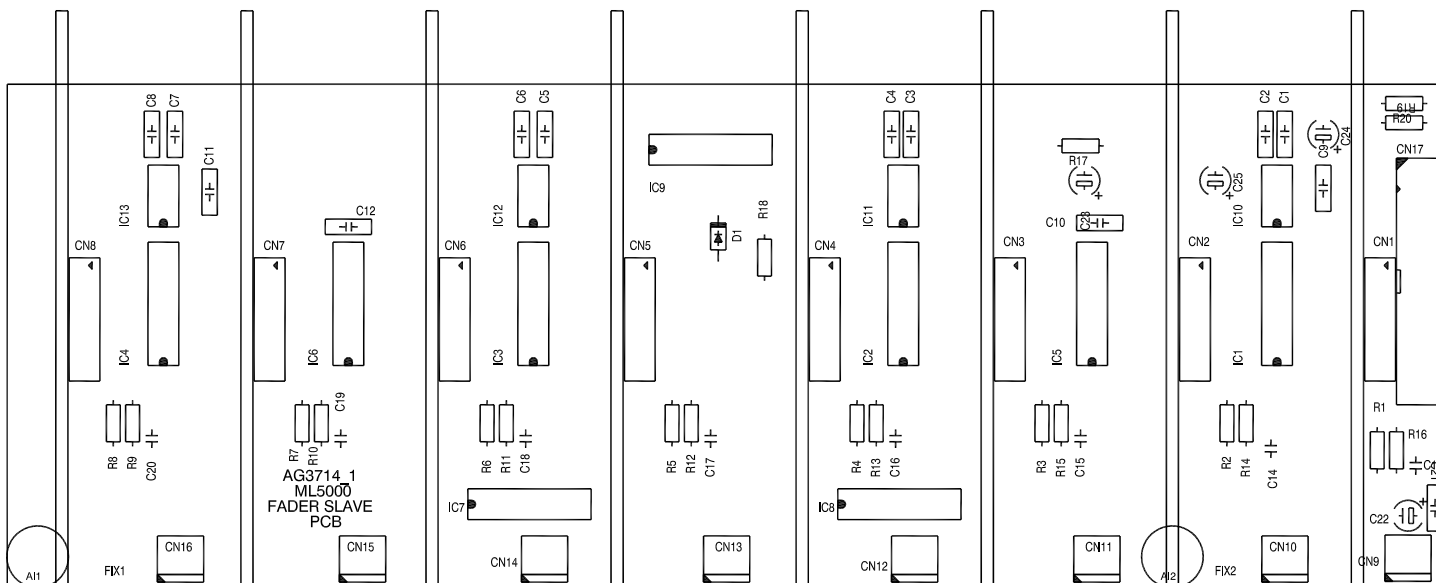

h  
g  
f  
e  
d  
c  
b  
a

CB=1-8  
CC=9-16  
CD=17-24  
CE=25-32  
CF=33-40  
CG=41-48

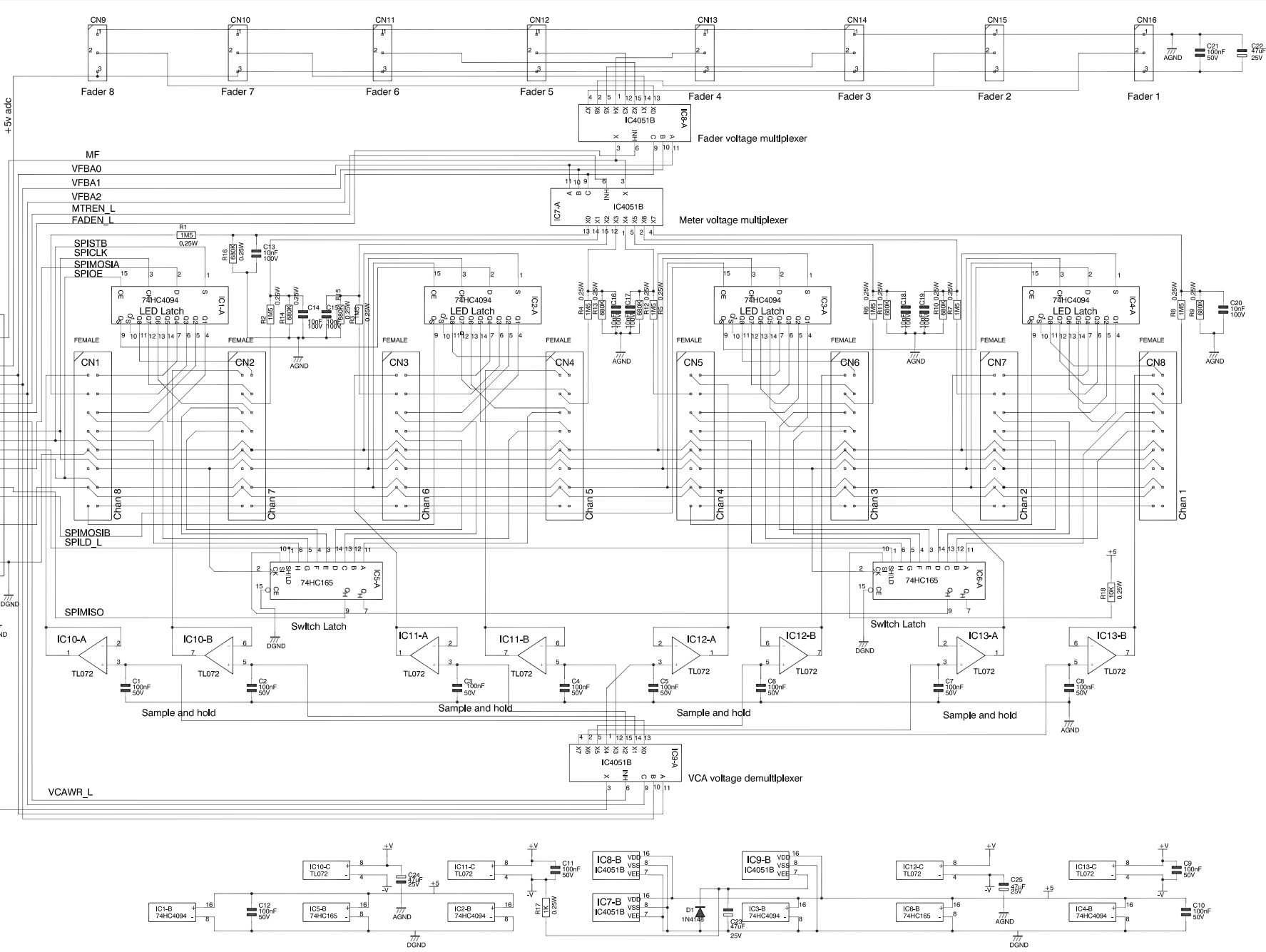

ML4000 MONO FADER SLAVE CIRCUIT C3714 issue 1 SHEET 1 of 1

ISS	REVISION	BY	DATE
A	ORIGIN	CMR	24-07-00
1	Serial data flow changes	AAT	02-12-09
1.1	GROUND PLANE ADDED C1-8 Change to 100N MLC	AAT	25-07-00

**ALLEN & HEATH**  
Kernick Industrial Estate,  
Penny, Cwmwell, England, TR10 9LU  
Tel: (44) (0) 1326 372070 Fax: (44) (0) 1326 365736

ML4000 MONO FADER PCB AG3713 issue 5

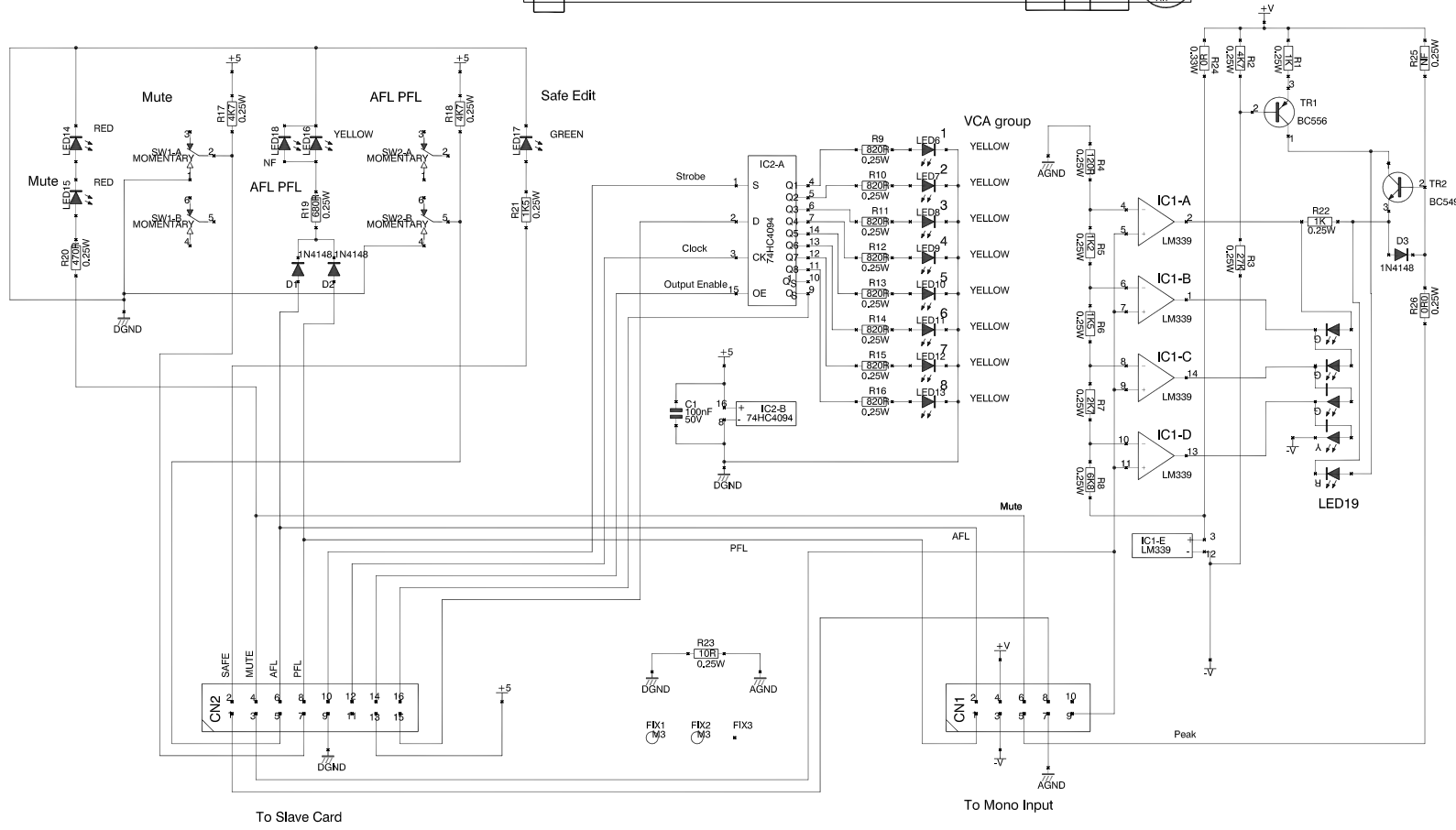
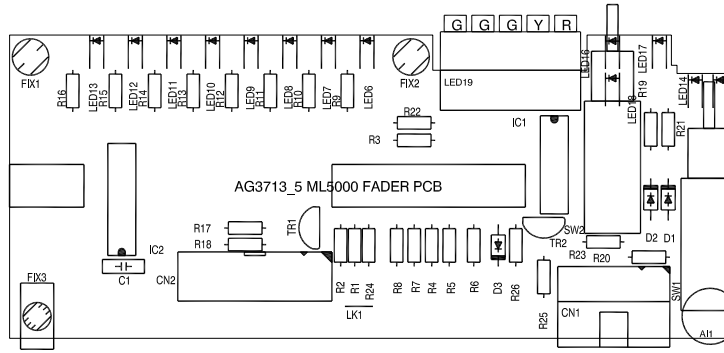

ML4000 MONO FADER CIRCUIT C3713 issue 5 SHEET 1 of 1

ISS	REVISION	BY	DATE
A	ORIGIN	GMR	19/7/99
1	GROUND PLANE ADDED (DGND) TO PCB	AAT	02-12-99
2	TR1, LEDS MOVED - VALUES	AAT	29-02-00
3	SQUARE LED HOUSING	AAT	13-07-00
4	LED HOUSING POSITION CORRECTION	AAT	14-11-00
5	EARTHING CORRECTION	AAT	17-11-00

**ALLEN & HEATH**  
 Komtek Industrial Estate,  
 Penryn, Cornwall  
 England, TR10 9LU  
 Tel: (44) (0) 1326 372070 Fax: (44) (0) 1326 365736



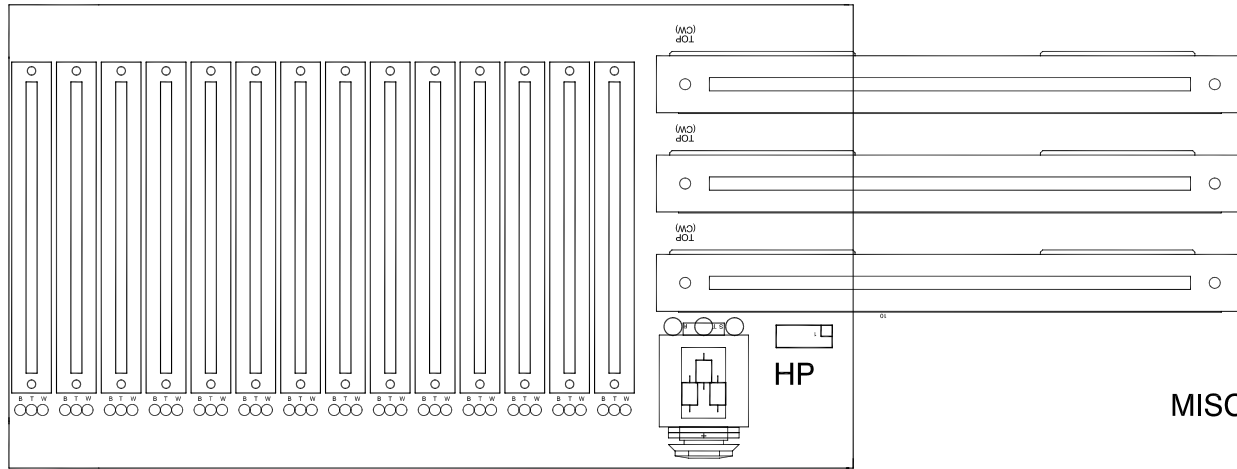

MISC BREAKOFF PCBs

14 X ALPS 60MM FADERS

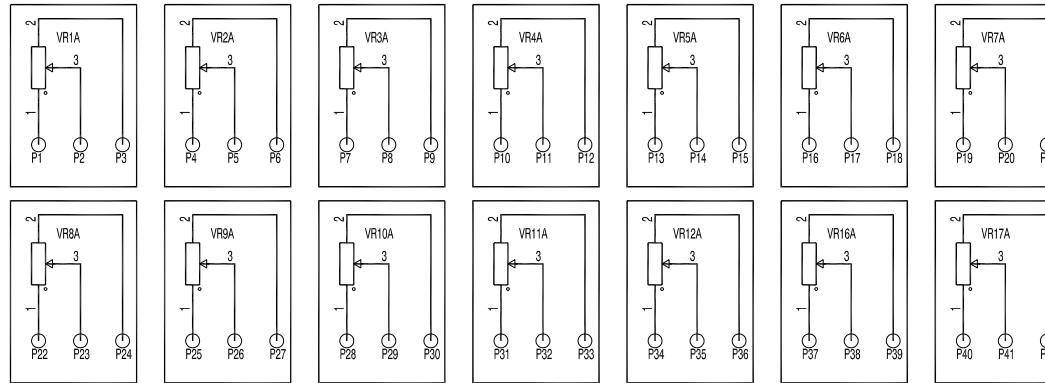

3 X ALPS 100MM FADERS

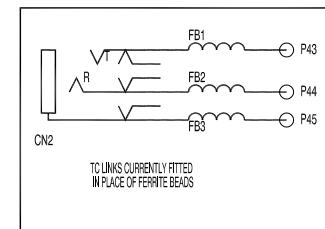
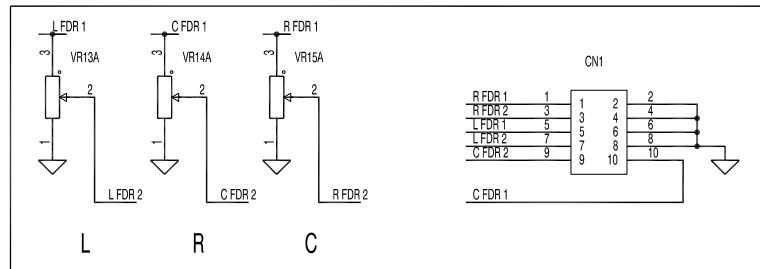

HEADPHONE CONNECTOR

ISSUE	BY	DATE
A	JB	26-10-00
1	JB	24-11-00
2	JB	18-12-00
3	JB	21-02-01

ML4000 FADER BISCUIT CIRCUIT C4299 issue 3 SHEET 1 of 1

**ALLEN&HEATH**  
 Kernick Industrial Estate,  
 Penryn, Cornwall,  
 England, TR10 9LU  
 Tel: (44) (0) 1326 372070 Fax: (44) (0) 1326 365736

# ML4000 SYSLINK OUT PCB AG4325 issue 1

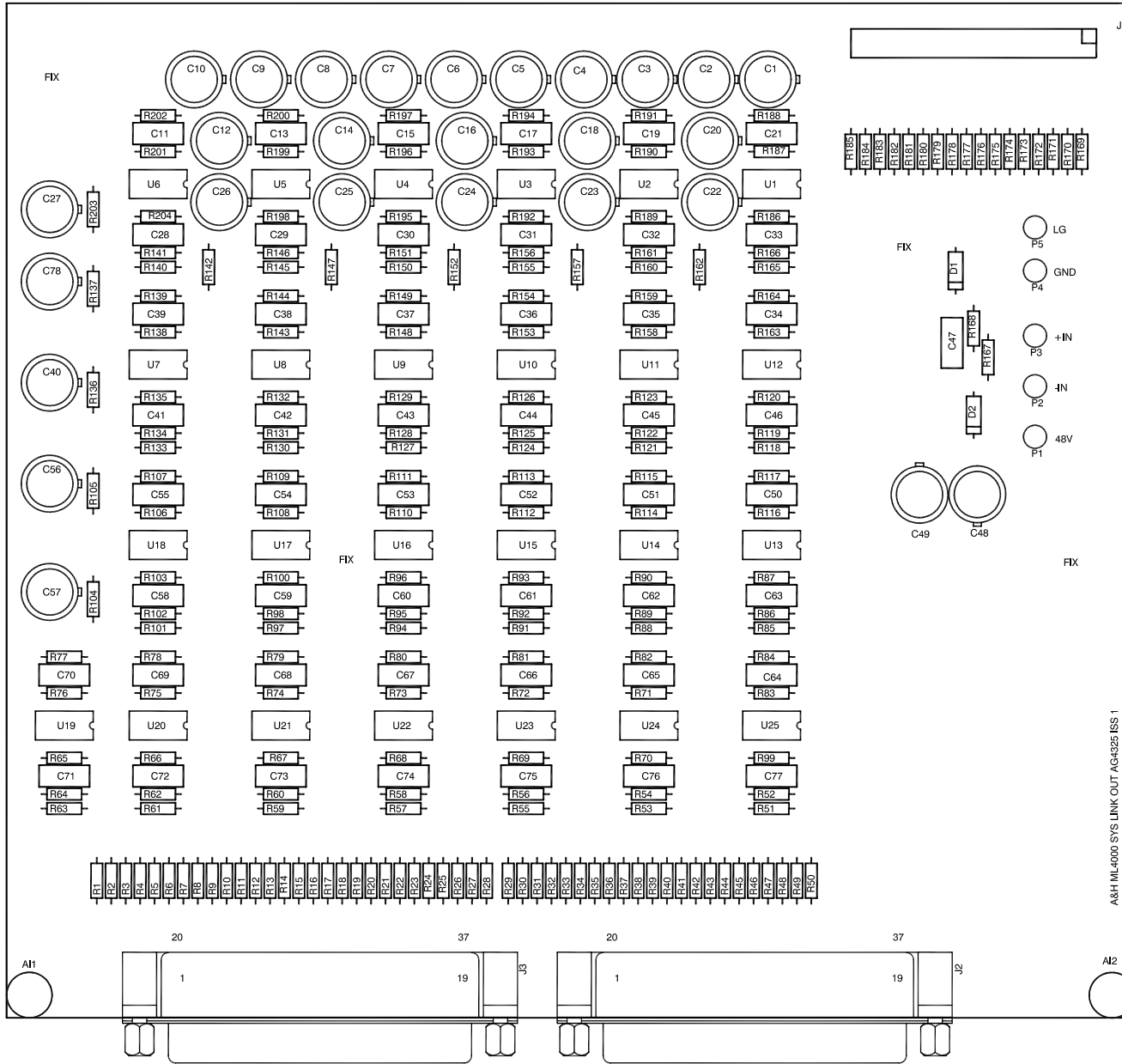

A&H ML4000 SYSLINK OUT AG4325 ISS 1

h  
g  
f  
e  
d  
c  
b  
a

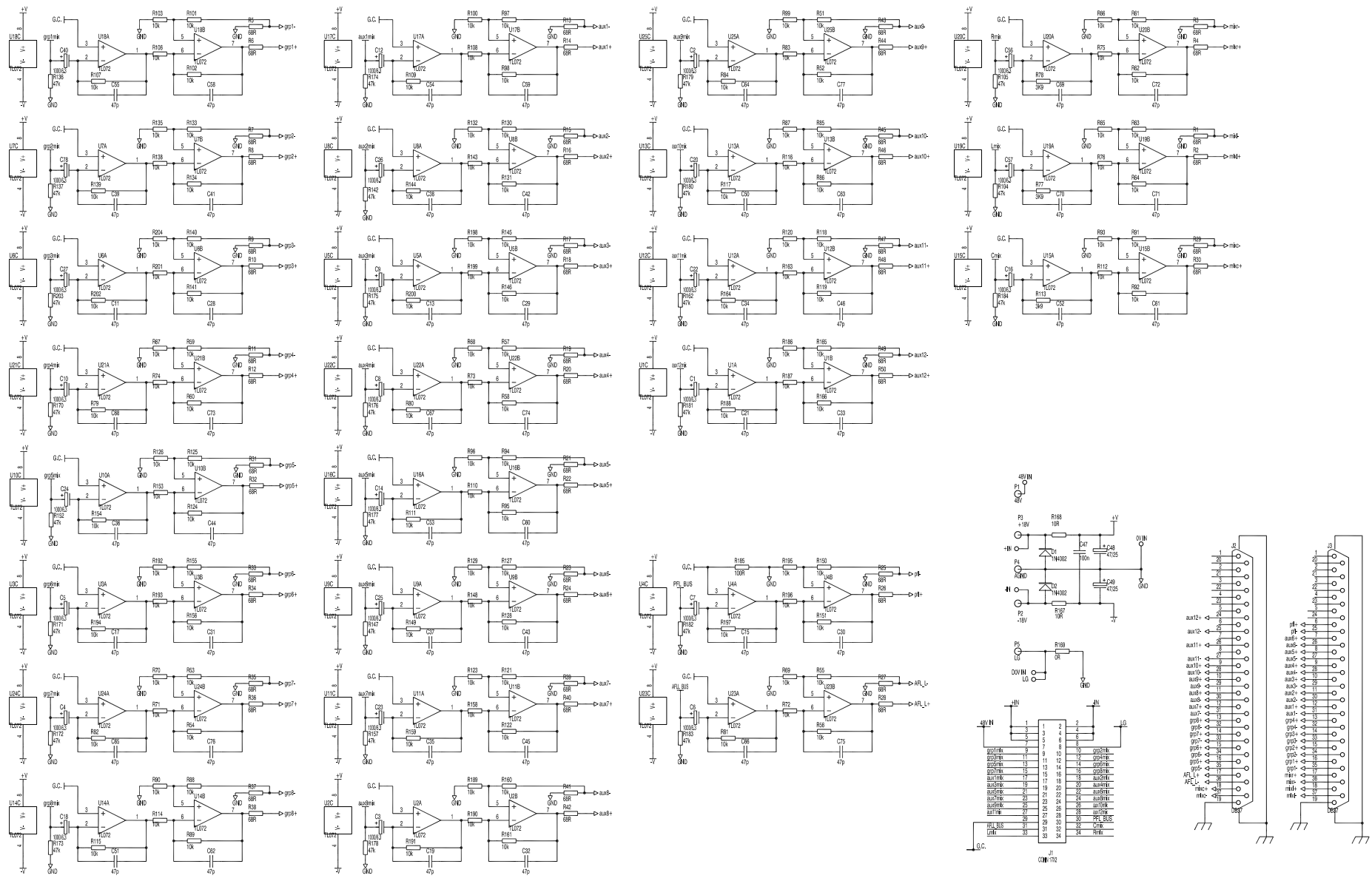

ISSUE	BY	DATE
A	JB	06-14-08
1	JB	148201

ML4000 SYSLINK OUTPUT CIRCUIT C4325 issue 1 SHEET 1 of 1

**ALLEN&HEATH**  
 Kernick Industrial Estate,  
 Fernyng, Cornwall,  
 England. TR10 5LU  
 Tel: (44) (0) 1326 372070 Fax: (44) (0) 1326 365736