

ALLEN & HEATH



WARNING – HIGH VOLTAGES

Power Supply Unit (PSU) work should only be carried out by qualified personnel.

We recommend that you use an approved Allen & Heath service centre for all power supply work.

Please contact your local Allen & Heath distributor for more details.

<http://www.allen-heath.com/>

ALLEN & HEATH



 **XONE:56**

SERVICE INFORMATION

Publication AP6297

Introduction

This publication provides technical information on servicing the Allen & Heath **Xone:S6** rotary club mixer. Included are internal layout drawings, block diagrams and circuit schematics with board layouts. Also included is technical information on the **Xone:V6** EQ Isolator and Crossfader modules, which are compatible with the **Xone:S6**. Please note that the valve circuits from the **Xone:V6** are not compatible with the **S6** and fitting of these parts should not be attempted. The **Xone:S6 MPS7** power supply unit should be used only to power a **Xone:S6** console.

Whilst we believe this information to be reliable we do not assume responsibility for inaccuracies. We also reserve the right to make changes in the interest of further product development.

Additional Resources

Allen & Heath web site	www.allen-heath.com	Product information Technical downloads Distribution contacts Company contacts
Technical support	support@allen-heath.com	See web for local contact
Xone:S6 user guide	AP6296	Operating instructions Performance specification User jumper link options Meter bulb replacement
Xone:V6 options user guide	AP5377	Operating instructions Performance specification

Xone:S6 Service Information

Issue status: **xones6_ap6297_1.doc**

Print date: **14 June 2005**

Copyright © 2005 Allen & Heath. All rights reserved

ALLEN&HEATH

Manufactured in the United Kingdom by Allen & Heath

Kernick Industrial Estate, Penryn, Cornwall, TR10 9LU, UK

<http://www.allen-heath.com>



Servicing Precautions – General Notes

- Service personnel:** Service work should be carried out by technically qualified service personnel only. Mains power is dangerous and can kill. Do not attempt to work on a linear or switched mode power supply if you are not suitably qualified to do so. Do not attempt to repair surface mount circuit assemblies unless you are suitably qualified and have the necessary facilities to do so. Replacement circuit assemblies can be ordered.
- Service facilities:** Ensure a suitably sized work surface is available. Ensure this is clear of dirt, debris and obstructions which may damage the equipment surfaces. Ensure adequate lighting. Use the correct tools for the job and ensure they are in good working order. Ensure all workshop safety requirements are adhered to.
- Service information:** Check that you have all the information you need before starting the service job. Refer to the Allen & Heath web site or contact Allen & Heath technical support for details on the latest information. Full technical information can be downloaded from the web site Distributor Zone (password required).
- Mains power:** Connect the equipment to mains power only of the type described in the user guide and marked on the rear panel. The power source must provide a good ground connection. Ensure you always use an isolation transformer when working on any mains power supply unit.
- Mains cord and fuse:** Use the correct power cord as supplied with the equipment. Do not remove or tamper with the ground connection in the power cord. Heed the Important Mains Plug Wiring Instructions printed in the user guide if it is necessary to rewire the mains cord. Always replace the equipment mains fuse with the correct type and rating as described in the user guide and marked on the equipment panel.
- Opening the unit:** Switch off and remove the mains power cord before opening the equipment. Ensure all power supply covers and safety shields are in place before applying power with the unit open for diagnostic fault finding.
- Closing the unit:** Before finishing, check the quality and accuracy of the service work carried out. Remove any dirt or debris as this may cause equipment failure in the future. Ensure all assemblies, harnesses and connectors are correctly aligned and plugged in. Ensure that jumper settings and control configurations are correctly set according to the requirements of the customer.
- Testing the unit:** Before operating the equipment, read and adhere to the Important Safety Instructions printed in the user guide. Test that the service work has been successfully carried out.
- Shipping the unit:** Use adequate packing such as the original packaging or purpose designed flight case if you need to ship the unit. To avoid injury to yourself or damage to the equipment take care when lifting, moving or carrying the equipment.



Servicing Notes – Xone:S6

- User maintenance:** There are several user configurable jumper links inside. These are described in the user guide together with instructions on how to change the default settings.
- Technology:** The **Xone:S6** uses conventional thru-hole PCB technology with high grade discrete transistor audio circuits. It has an external linear power supply which should be serviced only by suitably qualified personnel.
- Operation:** The **Xone:S6** is an audiophile rotary club mixer. To ensure optimum performance and reliability it should be connected and operated as described in the user guide.
- Fault finding:** Refer to the system block diagram and circuit drawings to follow through the signal path during fault diagnosis. Replace suspected faulty components only with those specified by Allen & Heath. The use of lower grade alternatives may degrade the performance. Ensure the RCA phono insert jumper links are pressed fully in if fitted. If a fault with the power unit is found, make sure it has been positioned according to the instructions in the user guide when installed. VU meter bulb replacement is described in the user guide.

Contents Log

Internal Layout drawing	xones6_layout_1.pdf
.....	xonev6_options_layout_1.pdf
Surface and Main Parts.....	xones6_parts_1.pdf
.....	xonev6_options_parts_1.pdf
System Block Diagram	xones6_blockdiagram_1.pdf
Input PCB	xones6_003-050_090_input_1.1.pdf
Master PCB	xones6_003-051_master_2.pdf
Mic PCB.....	xones6_003-052_mic_1.1.pdf
Booth PCB.....	xones6_003-053_booth_1.pdf
Phones PCB.....	xones6_003-054_phones_1.pdf
Meter PCB	xones6_003-471_meter_1.pdf
Slave PCB	xones6_003-472_slave_1.pdf
Power Supply PCB.....	xones6_003-470_power_1.pdf
Crossfader Option PCB	xonev6_options_003-154_xfader_2.pdf
EQ Isolator Option PCB	xonev6_options_003-156_eqiso_2.pdf

XONE:S6 Internal Layout

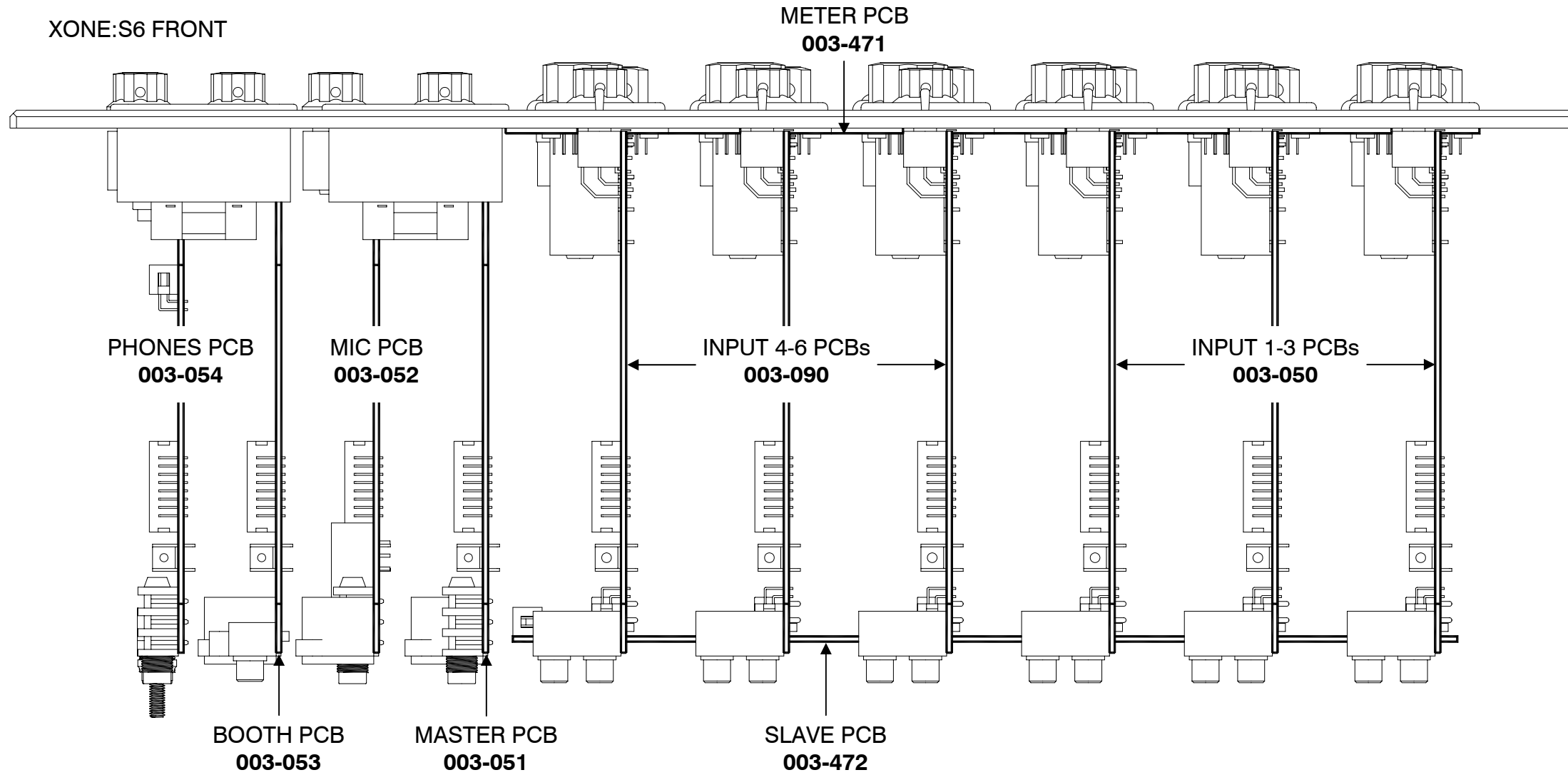

Product.....XONE:S6

Power Supply VersionsMPS7-100
MPS7-120
MPS7-220
MPS7-240

DC Cable Assembly 002-583
 Pack Assembly 003-465
 Main Assembly 003-466
 Panel Assembly Front 003-467
 Chassis Assembly 003-468
 PSU Assembly 003-469
 Cue Switch Cable Assembly ... 003-089
 Fader Assembly 003-109
 VU Meter Assembly..... 003-110

Input 1-3 PCB..... 003-050
 Input 4-6 PCB..... 003-090
 Master PCB 003-051
 Mic PCB 003-052
 Booth PCB..... 003-053
 Phones PCB..... 003-054
 Meter PCB..... 003-471
 Slave PCB 003-472
 Power PCB..... 003-470

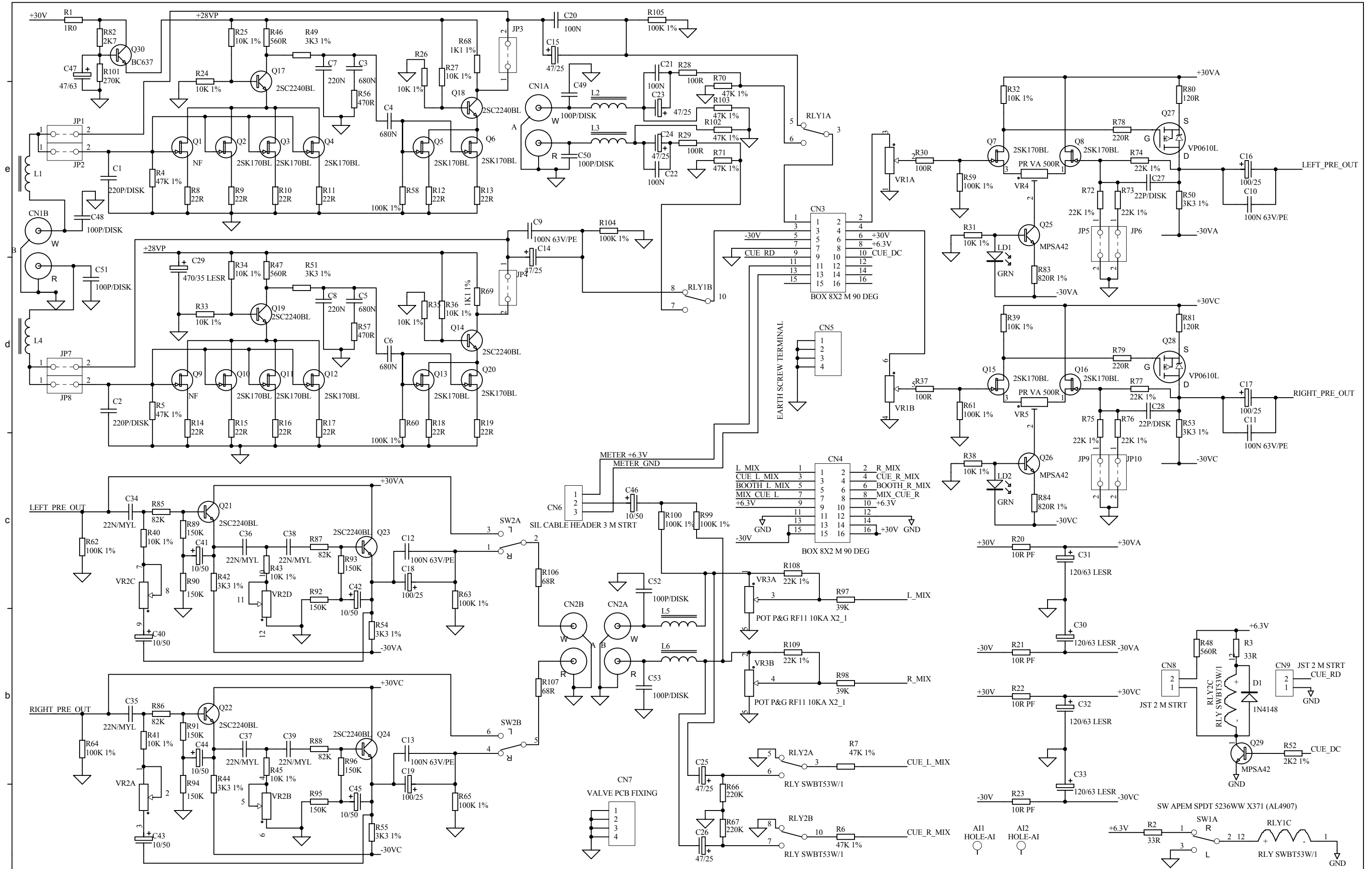

ALLEN&HEATH
 Kernick Industrial Estate,
 Penryn, Cornwall,
 England. TR10 9LU
 Tel: +44 (0)8707 556250
 Fax: +44 (0)8707 556251

ISSUE	BY	DATE
1	ARJ	27-08-02
1.1	ARJ	26-11-02

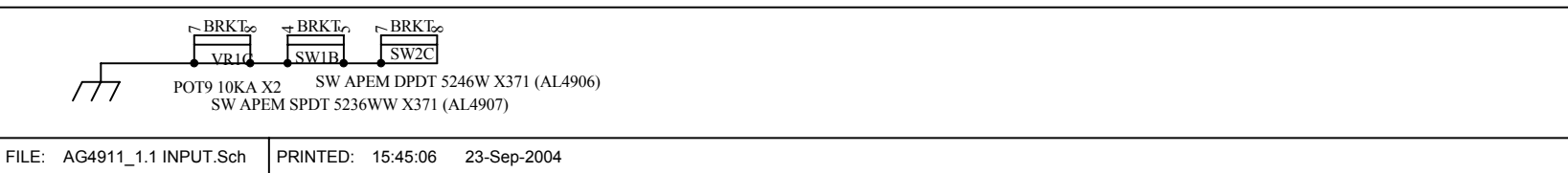

TITLE: **XONE S6 INPUT PCB**
 PAGE:
 DRG No: C 4911 ISSUE: 1.1 SHEET: 1 OF 1

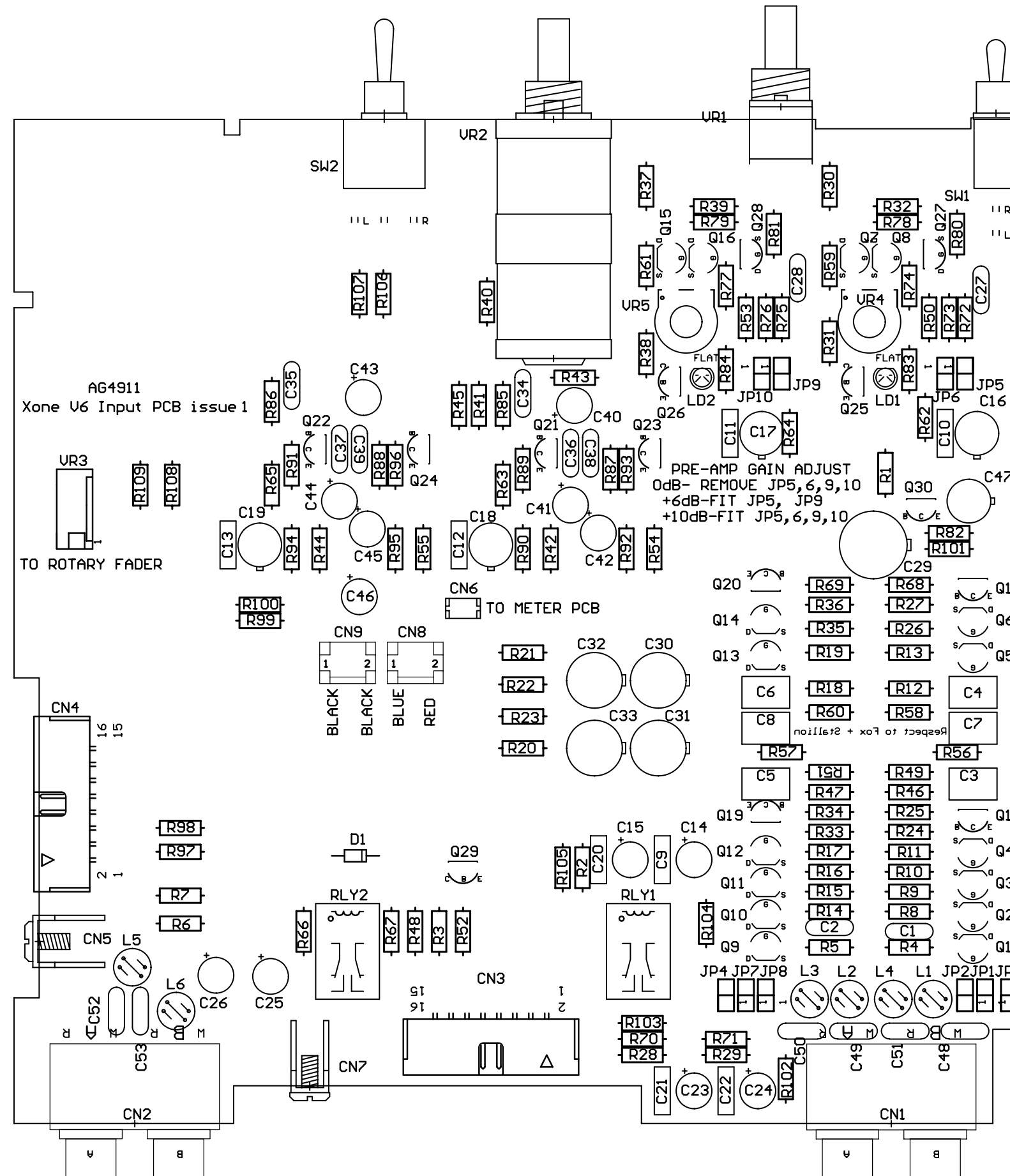

RIAA disable

CH1-3. For RIAA gain and equalisation JP2, JP3, JP4 and JP8 are fitted. This is the factory default setting. To disable RIAA and use these inputs with line sources, remove those jumpers and fit JP1 and JP7 instead.

Gain setting

CH1-6. The maximum preamp gain available is set using these jumpers. For +10dB gain all four jumpers JP5, JP6, JP9 and JP10 are fitted. This is the factory default setting. To change this to +6dB gain fit JP5 and JP9 only. For 0dB gain remove all four jumpers.

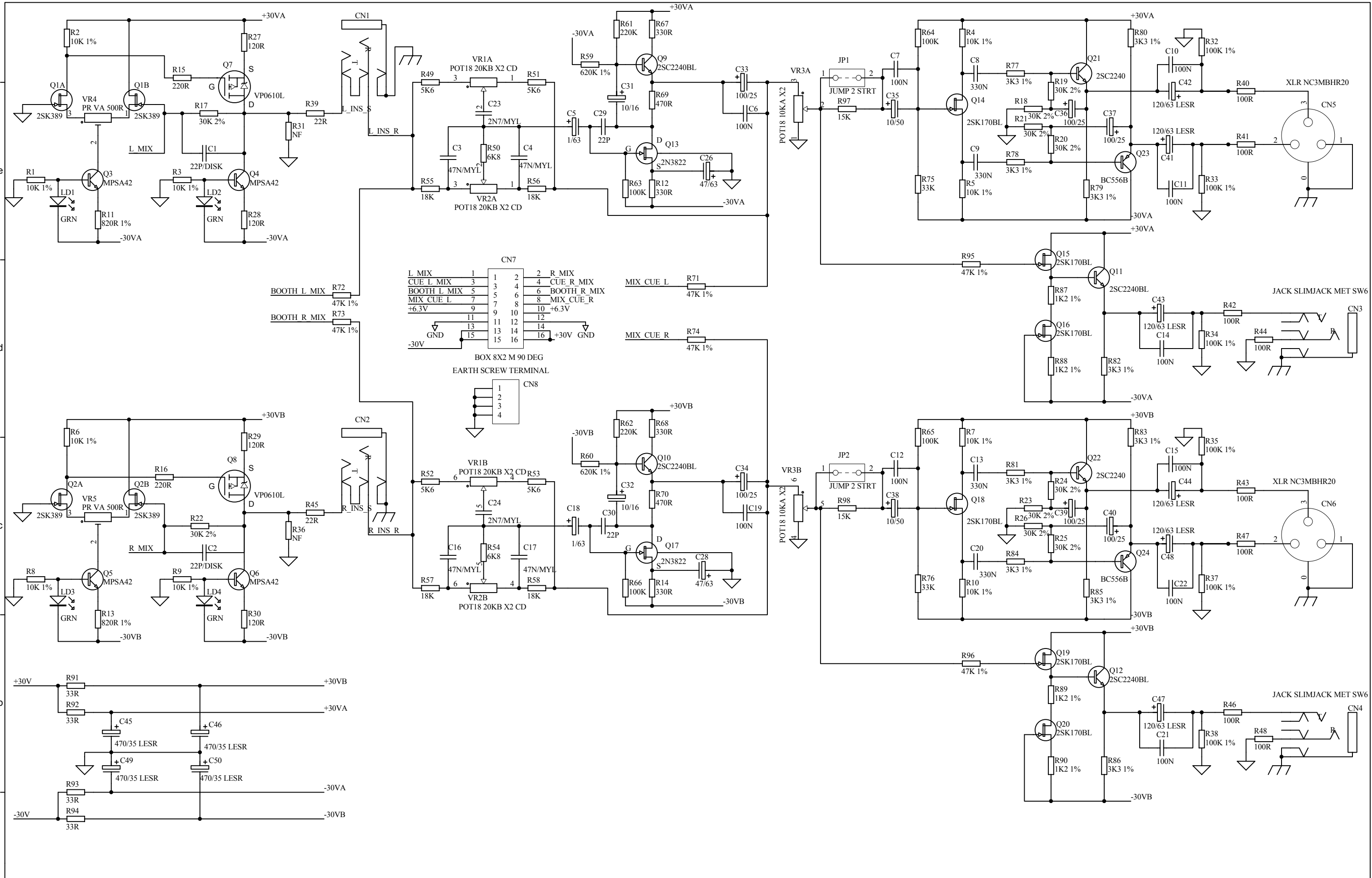

ALLEN&HEATH Kernick Industrial Estate, Penryn, Cornwall, England. TR10 9LU Tel: +44 (0)8707 556250 Fax: +44 (0)8707 556251	ISSUE	BY	DATE	A11	A12	TITLE: XONE S6 MASTER PCB PAGE:
	1	ARJ	2-09-02	HOLE-A1	HOLE-AI	
	2	ARJ	31-10-02			ISSUE: 2 SHEET: 1 OF 1
FILE: AG4912 iss 2 Master.Sch		PRINTED: 13:58:36 23-Sep-2004				

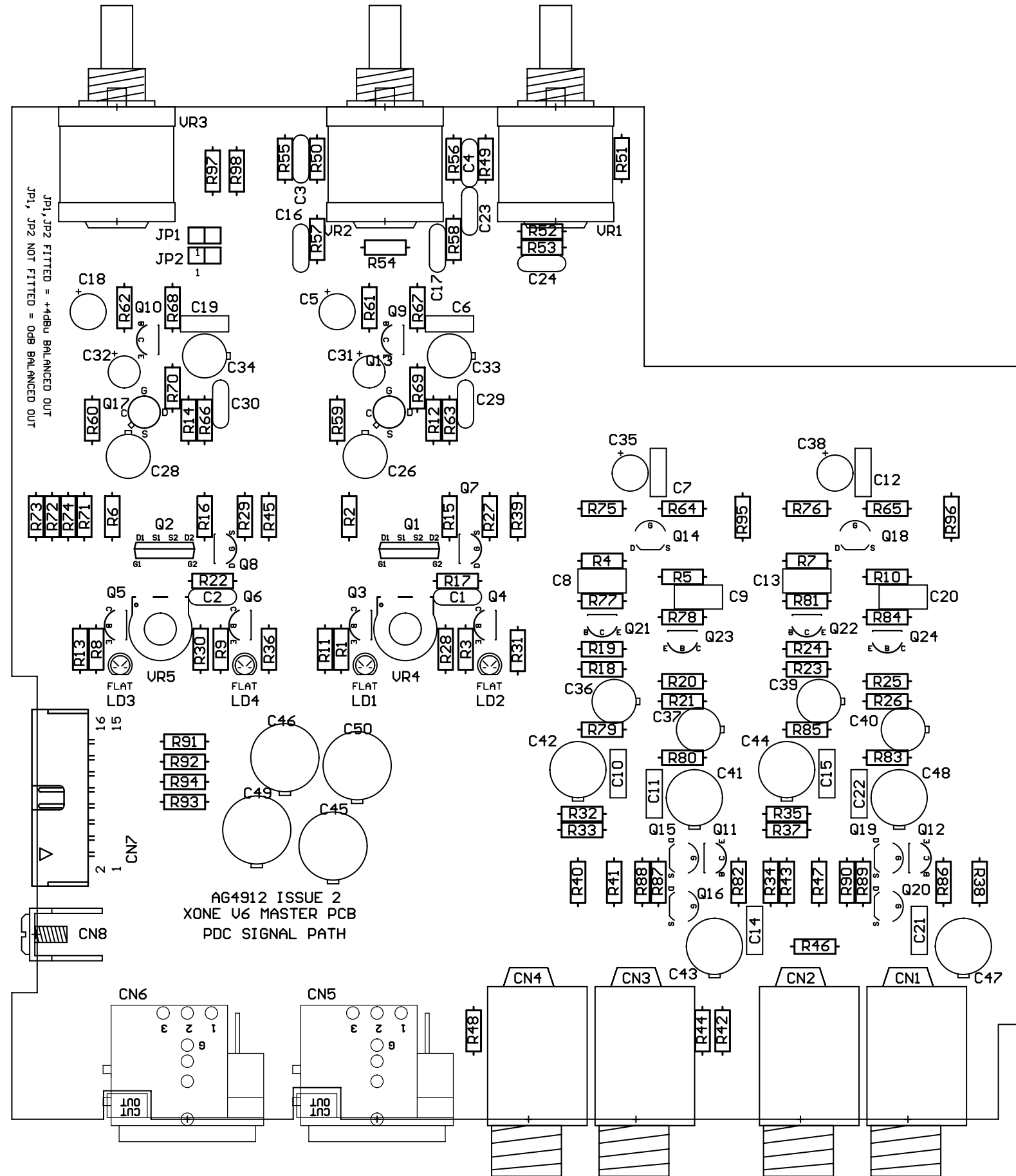

Master output level

The output level with MASTER control at maximum position and VU meters reading '0' is +4dBu with JP1 and JP2 fitted. This is the default factory setting. To change this to 0dBu remove JP1 and JP2. Access these jumpers from below the console.

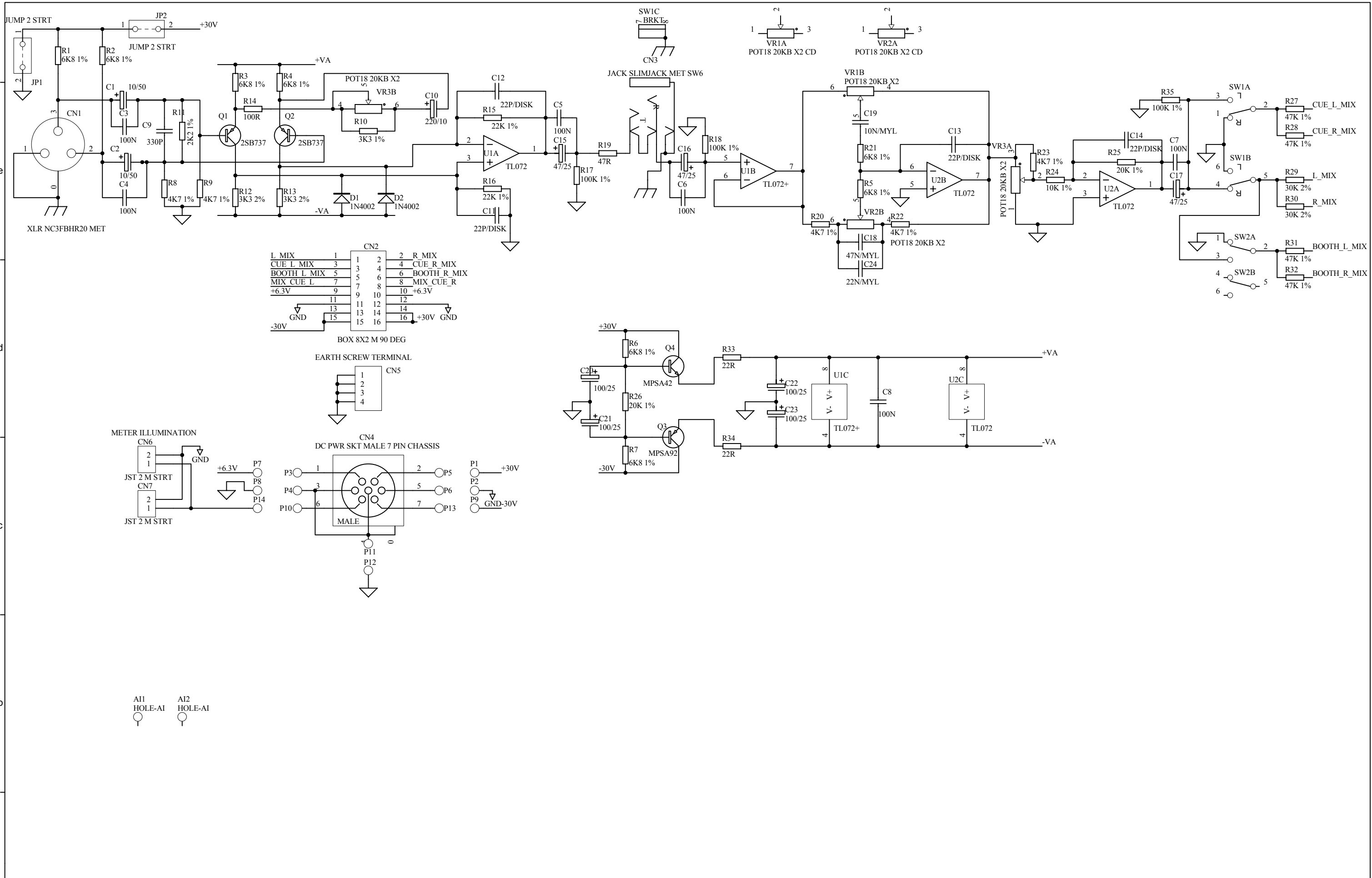

ALLEN&HEATH Kernick Industrial Estate, Penryn, Cornwall, England. TR10 9LU Tel: +44 (0)8707 556250 Fax: +44 (0)8707 556251	ISSUE	BY	DATE	TITLE: XONE S6 MIC PCB PAGE:
	1 1.1	ARJ ARJ	20-09-02 14-05-03	
FILE: AG4913 ISS 1.1 Mic.Sch PRINTED: 13:44:03 23-Sep-2004				

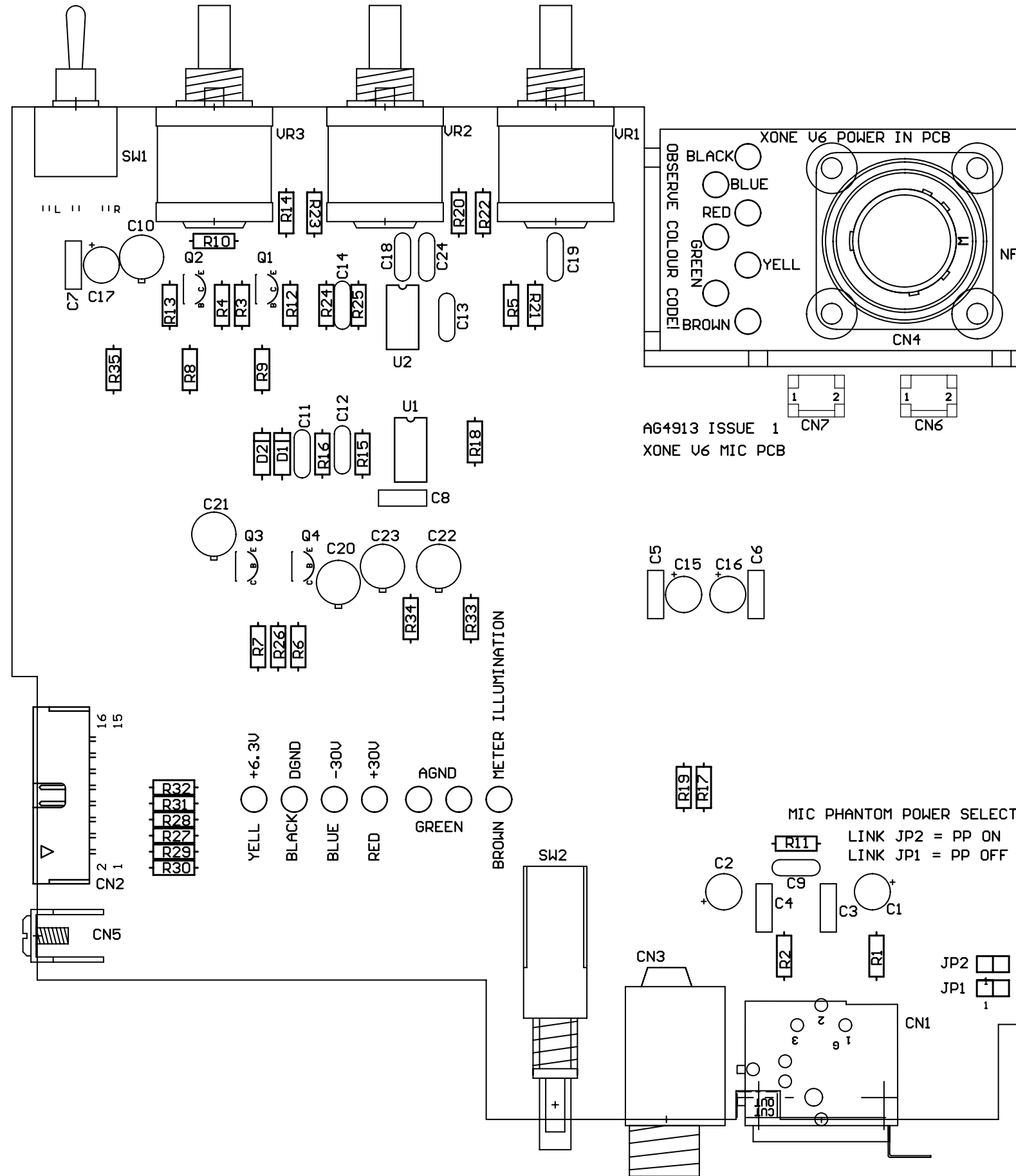

Phantom power

30V phantom power is disabled when JP1 is fitted. This is the default factory setting. Plug the jumper on to JP2 instead if you wish to turn phantom power on.

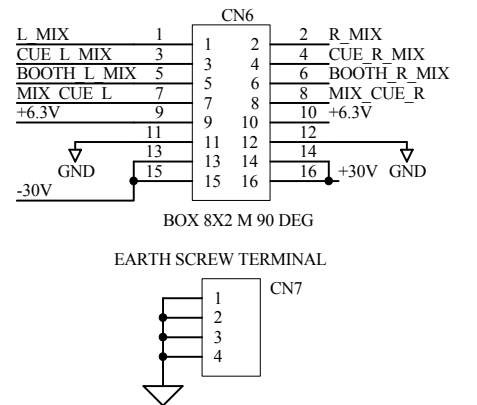
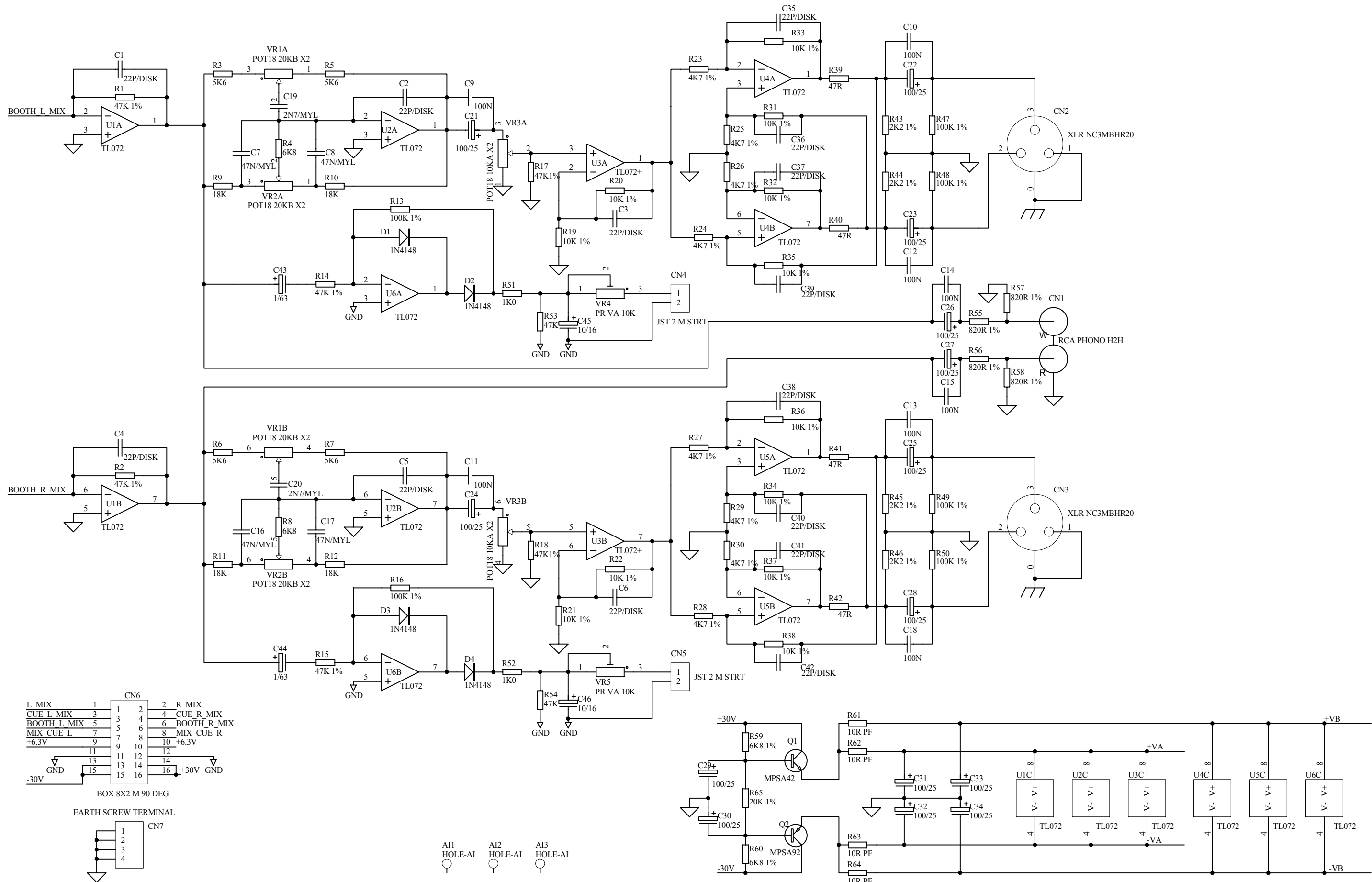

ALLEN&HEATH Kernick Industrial Estate, Penryn, Cornwall, England. TR10 9LU Tel: +44 (0)8707 556250 Fax: +44 (0)8707 556251	ISSUE	BY	DATE	TITLE: XONE S6 BOOTH PCB		
	1	ARJ	30-08-02	PAGE:		
FILE: AG4914 iss 1 Booth.Sch		PRINTED: 14:00:03 23-Sep-2004		DRG No: C4914		ISSUE: 1 SHEET: 1 OF 1

003-053 iss.1

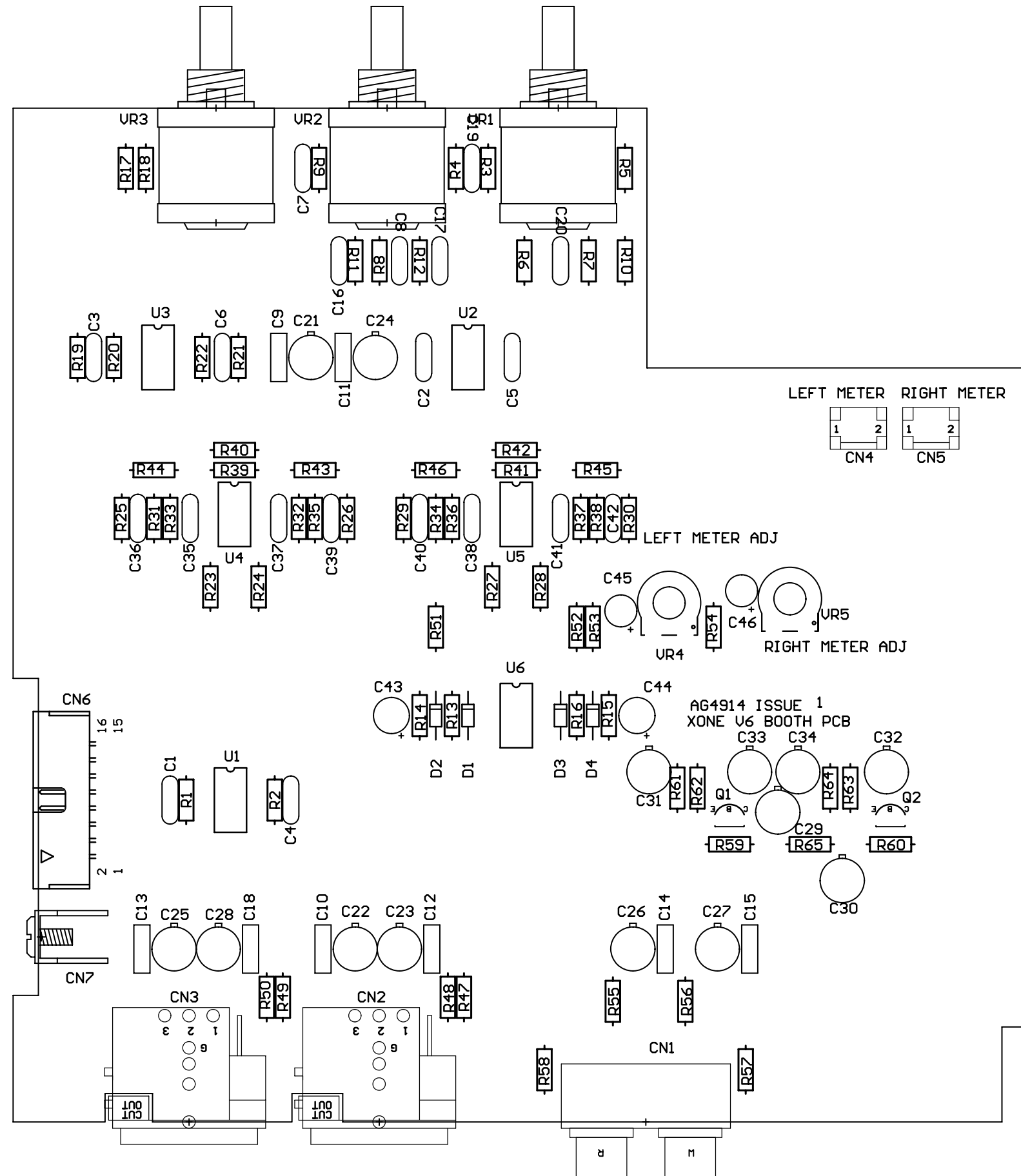

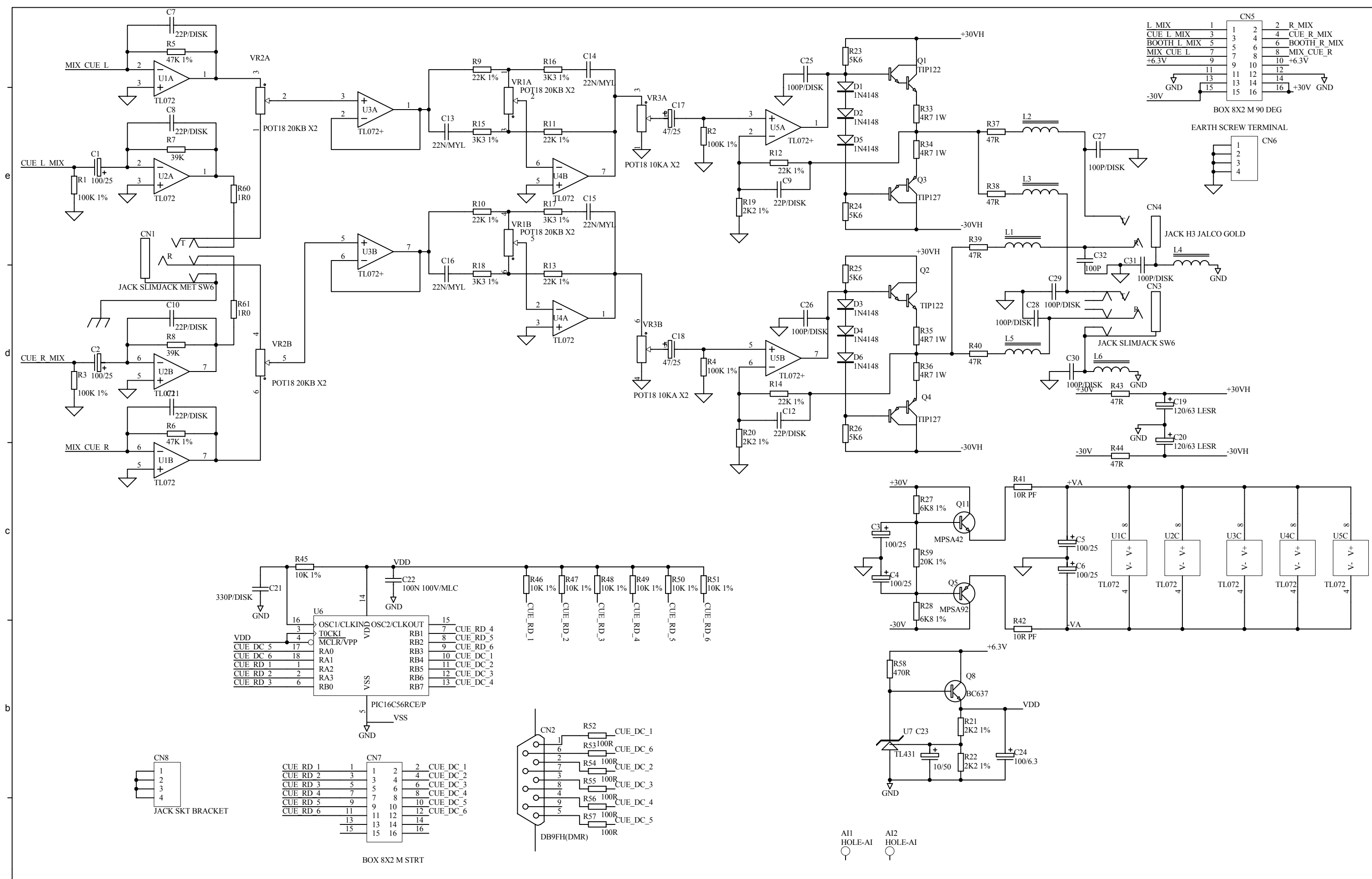

ALLEN&HEATH Kernick Industrial Estate, Penryn, Cornwall, England. TR10 9LU Tel: +44 (0)8707 556250 Fax: +44 (0)8707 556251	ISSUE	BY	DATE	TITLE: XONE S6 PHONES PCB PAGE:
	1	ARJ	02-09-02	
FILE: AG4915 ISS 1 Phones.Sch		PRINTED: 14:05:28 23-Sep-2004		

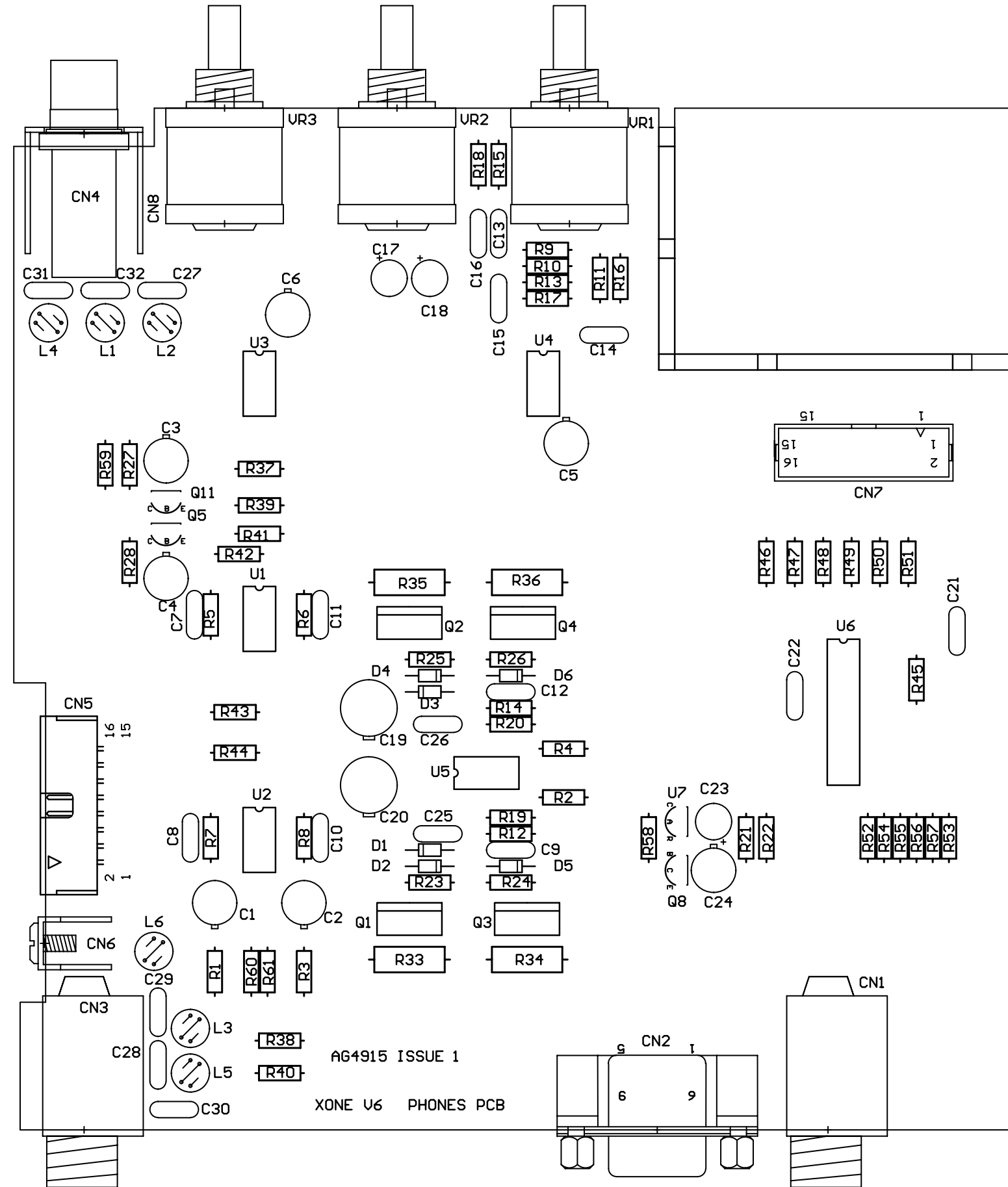

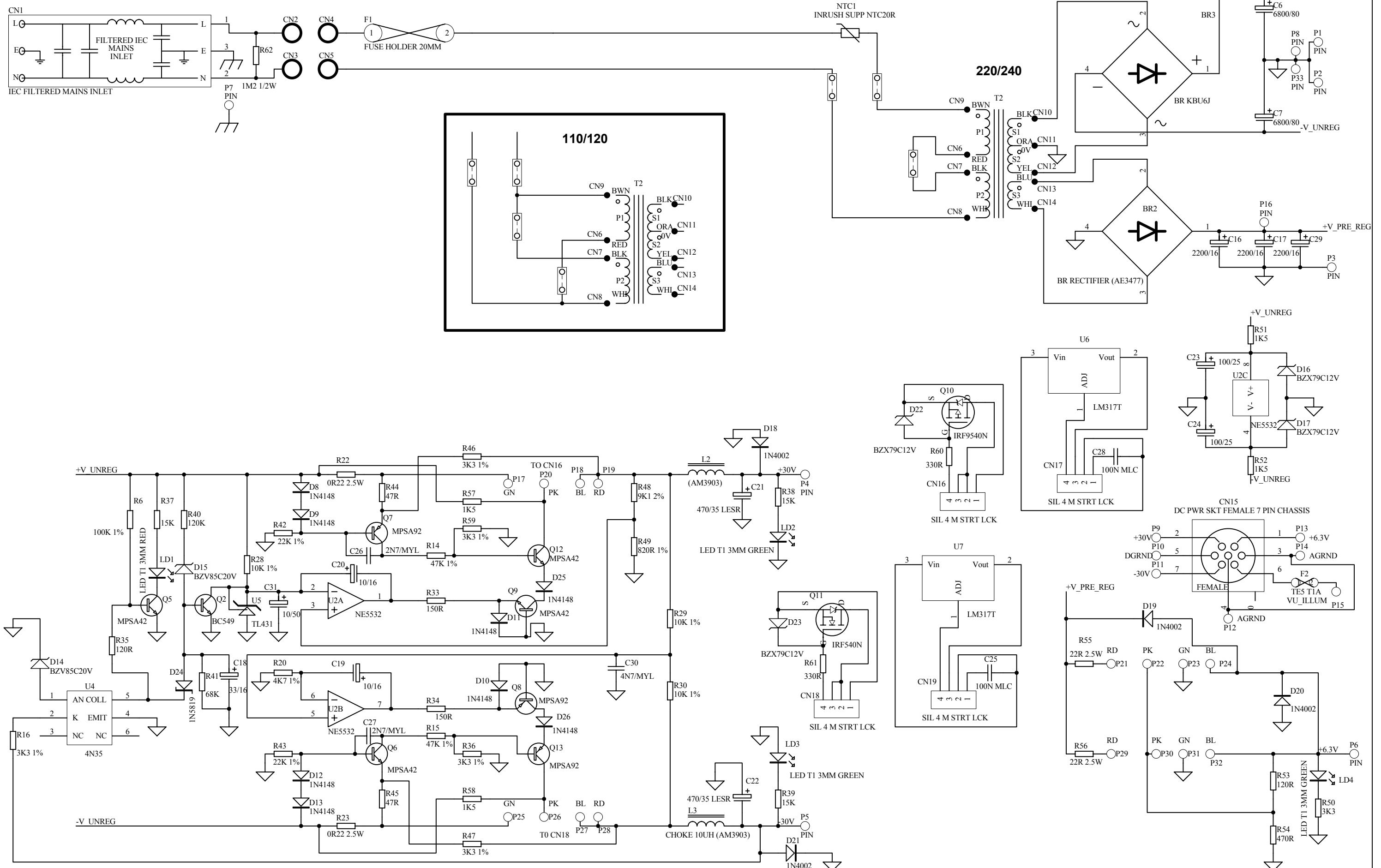

ALLEN&HEATH
 Kernick Industrial Estate,
 Penryn, Cornwall,
 England. TR10 9LU
 Tel: +44 (0)8707 556250
 Fax: +44 (0)8707 556251

ISSUE	BY	DATE
1	ARJ	27-05-05

FH1	FH4	FH7
○	○	○
○	○	○
○	○	○
○	○	○

NOTE
 TO IMPROVE HOT START WITH ALL OPTIONS CHANGE
 R44/R45 FROM 47R TO 33R
 R46/R47 FROM 3K3 TO 4K7

FILE: AG4918 EDIT ISS 1 Power supply.Sch

PRINTED: 10:18:10 14-Jun-2005

TITLE: **XONE S6 POWER SUPPLY**
 PAGE:
 DRG No: C4918 ISSUE: 1 SHEET: 1 OF 1

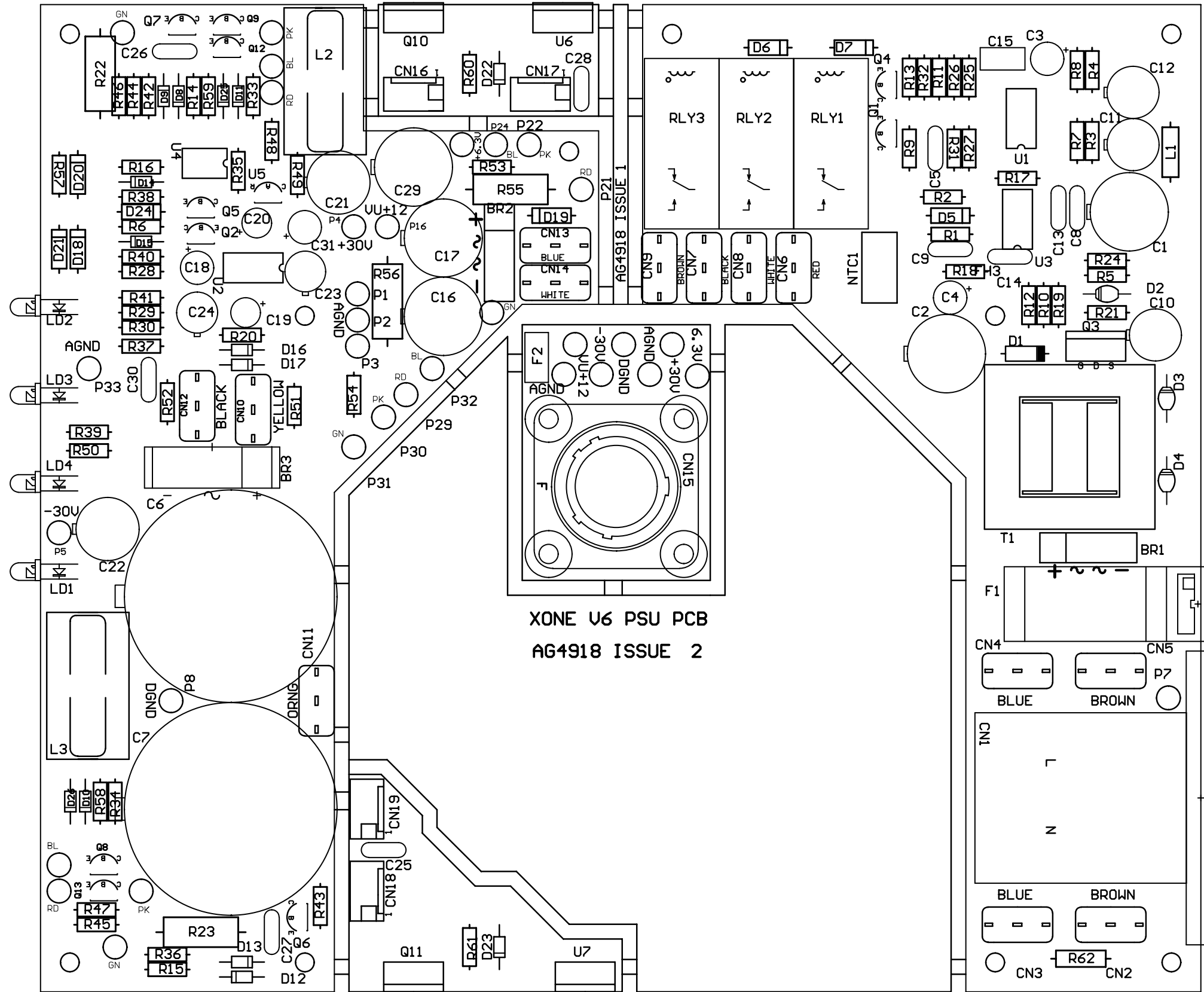

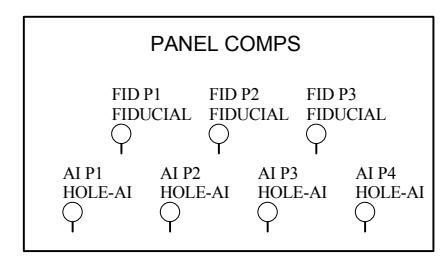
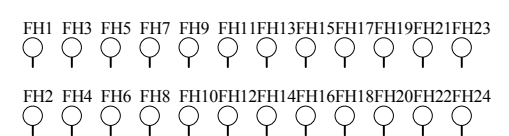
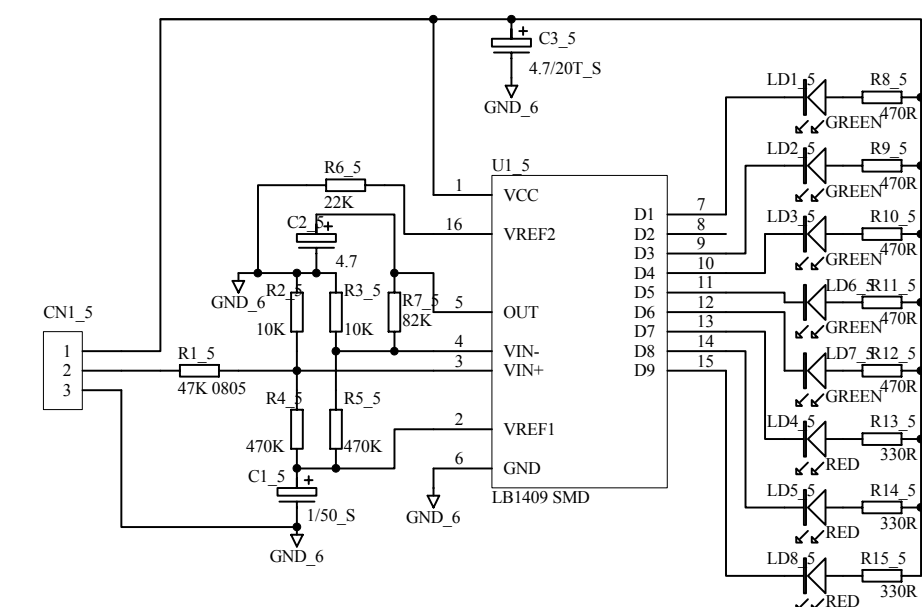
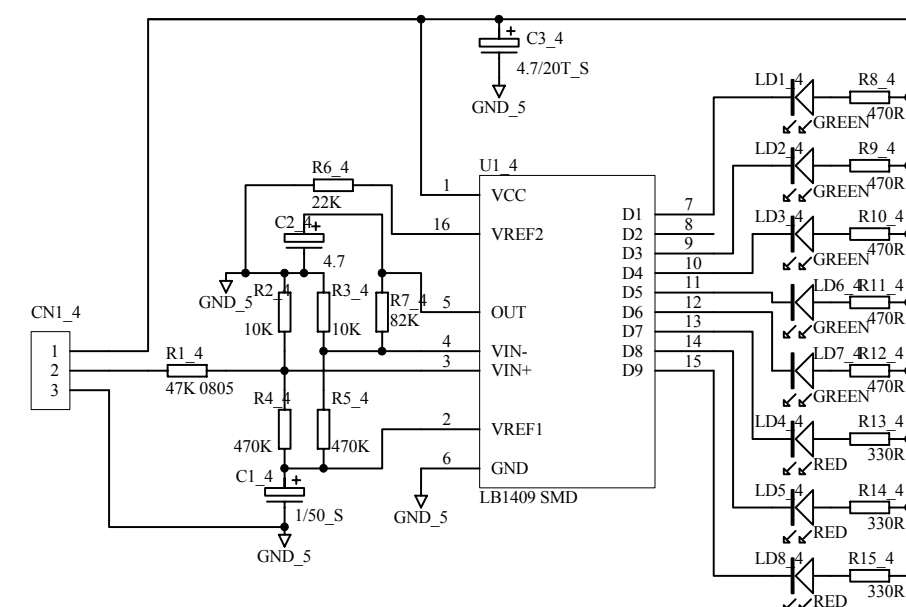
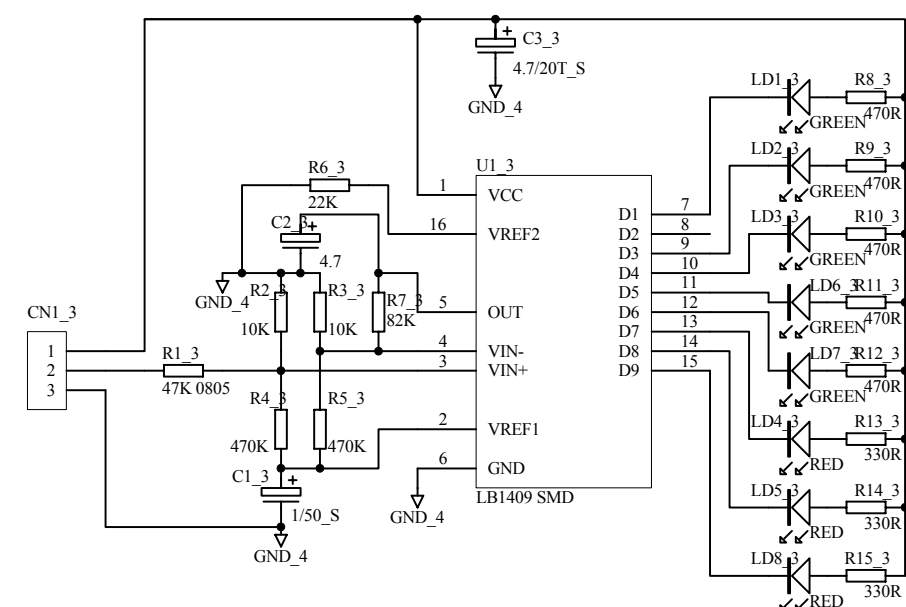
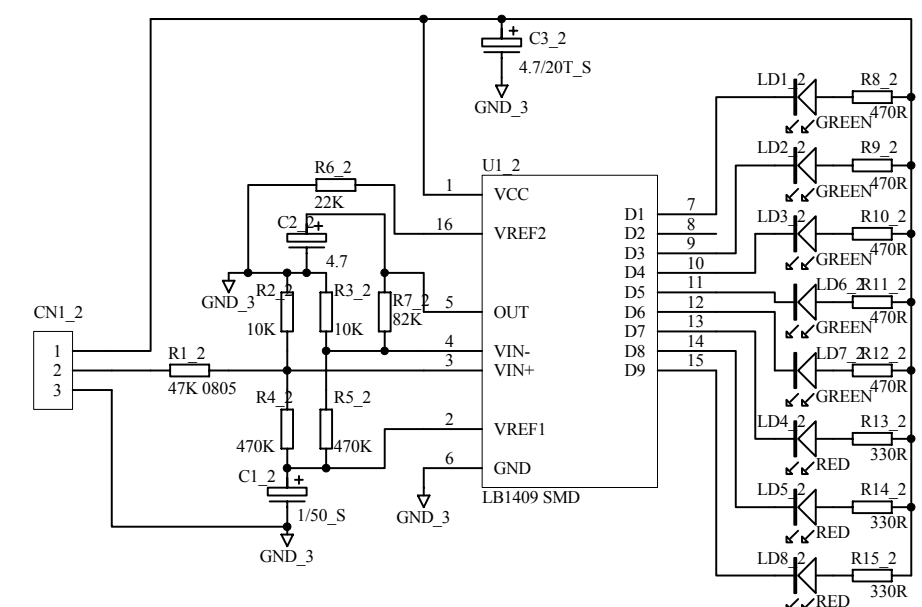
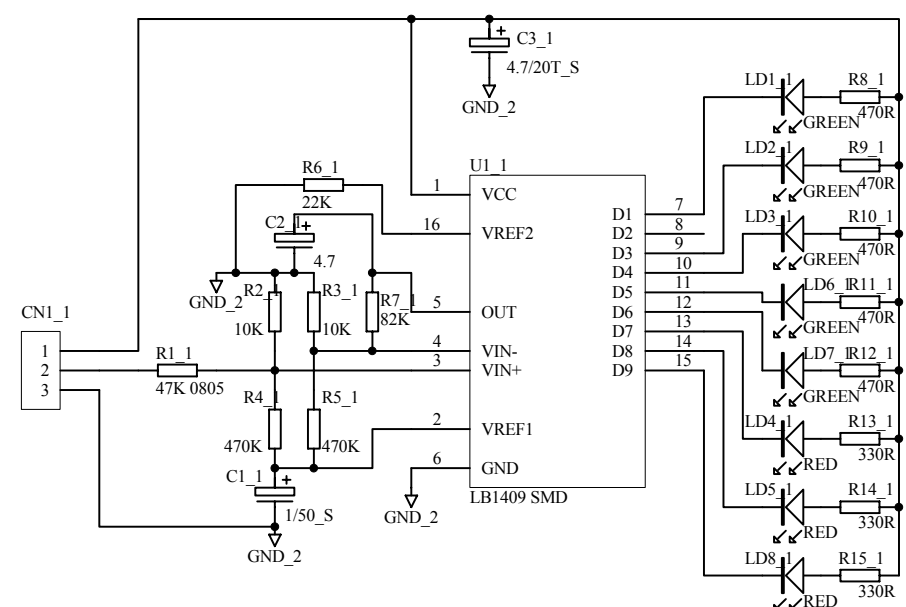
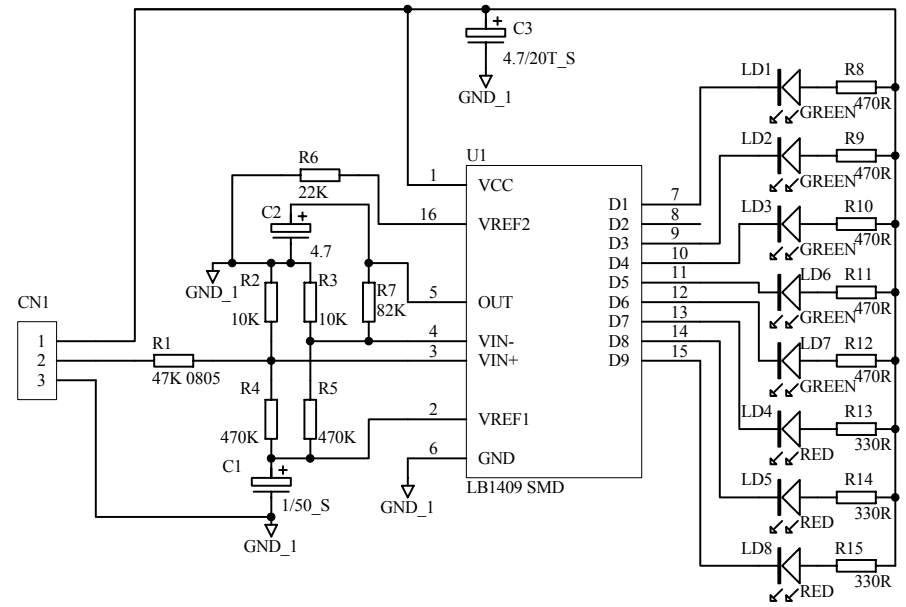

ALLEN&HEATH
 Kernick Industrial Estate,
 Penryn, Cornwall,
 England. TR10 9LU
 Tel: +44 (0)8707 556250
 Fax: +44 (0)8707 556251

ISSUE	BY	DATE	CHK BY
1	ARJ	27-05-05	

FILE: C4916_2 S6 LED METER.Sch

PRINTED: 09:55:53 14-Jun-2005

TITLE: XONE S6 LED METERS PCB
 PAGE:
 DRG No: C4916 ISSUE: 1 SHEET: 1 OF 1

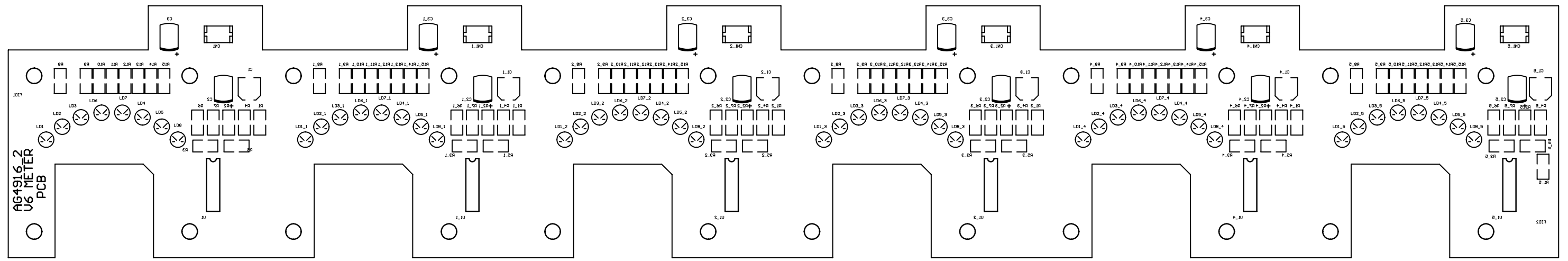

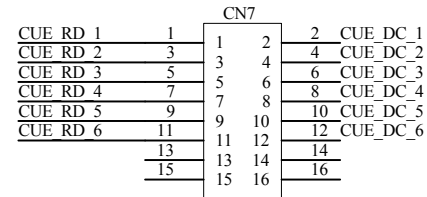
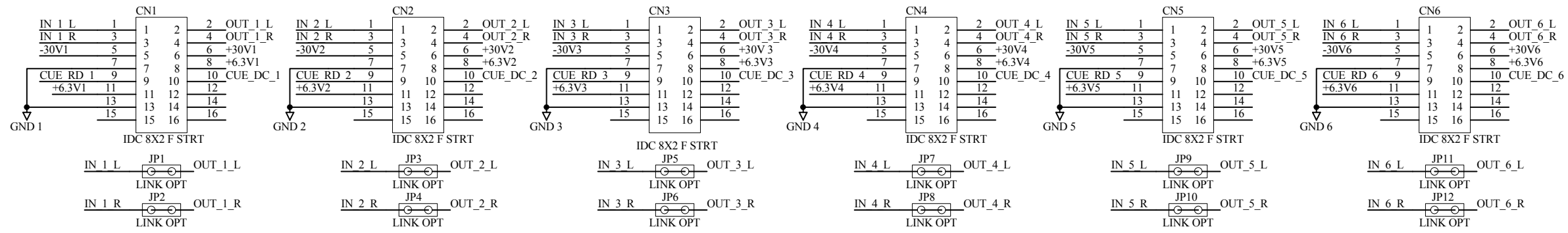

BOX 8X2 M STRT

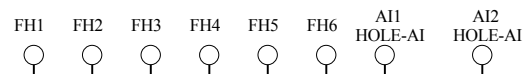

ALLEN&HEATH
 Kernick Industrial Estate,
 Penryn, Cornwall,
 England. TR10 9LU
 Tel: +44 (0)8707 556250
 Fax: +44 (0)8707 556251

ISSUE	BY	DATE
1	ARJ	27-05-05

Value changes
FILE: AG4917 ISS 1 EDIT S6 SALVE CARD.Sch
PRINTED: 09:32:45 14-Jun-2005

TITLE: XONE S6 SLAVE PCB
PAGE:
DRG No: C4917 ISSUE: 1 SHEET: 1 OF 1

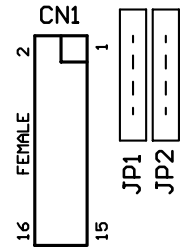

FH1

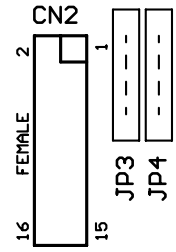

FH2

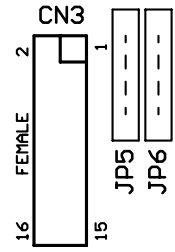

FH3

AG4917 ISSUE 1
XONE U6 VALVE CARD

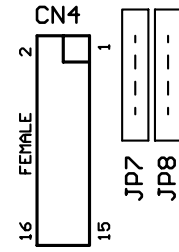

FH4

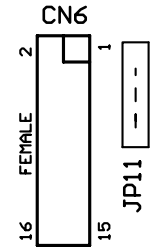
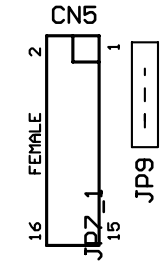

FH6

