

PSU not included in public version. Please see distributor version.

ALLEN & HEATH

GL4000

Dual Function Audio Mixing Console

SERVICE MANUAL

PUBLICATION: AP2640

INTRODUCTION

The information presented in this manual is intended for competent technical personnel to carry out service and product support for the **GL4000**. It is assumed that the reader is familiar with the related electronic theory and audio terminology, and is able to carry out basic servicing, fault-finding and repair of audio equipment of this type. Service personnel should also be familiar with audio systems, mains earthing and power requirements, as well as handling precautions.

For further information on the operation and application of the **GL4000** please refer to the **USER GUIDE** publication **AP2642** supplied with each console.

Whilst we believe the information in this manual to be reliable we do not assume responsibility for inaccuracies. We also reserve the right to make changes in the interest of further product development.

SERVICE AND TECHNICAL SUPPORT

Under normal conditions the **GL4000** does not require user maintenance or internal calibration. Any service work required should be carried out by qualified technical personnel only.

We are able to offer further product support through our worldwide distribution network. To help us provide the most efficient service please would you quote the console serial number in any communication regarding this product.

SAFETY WARNING !

Mains electricity is dangerous and can kill. Mains voltage is present within the console power supply unit. Do not remove the top cover with mains connected. Do not carry out any work within the unit while it is powered. High voltage components are insulated for safety but should not be touched with power applied. The mains voltage setting is factory set and is indicated on the rear panel. Check that this matches your local mains supply. Check your mains wiring and earthing before switching on.

DO NOT REMOVE THE MAINS EARTH CONNECTION!

The console chassis is always connected to mains earth.

This manual is printed in four sections:

SECTION A provides all the technical information and service procedures. It also details how to order spare parts for the **GL4000** console and **meterpod**, the **RPS11** power supply unit and the **RPSD2** dual supply combiner/monitor. The contents of the **GL4000** spares kits is also listed.

SECTION B contains the fitting instructions for the **expander and add-on** options.

SECTION C contains all the technical diagrams for the **GL4000** console, the **meterpod** option and the **SYS-LINK** option. Any technical bulletins are also in this section. Technical information for the console power supply is given in Section D.

SECTION D contains all the technical diagrams and information for the console power supply unit. Spare parts and assemblies for the power supply are listed in Section A.

SECTION E contains all the technical diagrams and information for the **RPSD2** dual supply combiner/monitor. Spare parts and assemblies for the **RPSD2** are listed in Section A.

CONTENTS

SECTION A

TECHNICAL DESCRIPTION	2
STANDARD CONSOLE FORMATS & OPTIONS	3
GL4000 DIMENSIONS FOR FLIGHT CASING	4
GL4000M DIMENSIONS FOR FLIGHT CASING	5
SPECIFICATION	6
CONNECTIONS	7
REMOVING A CHANNEL, GROUP, L/R, MONO or MASTER CIRCUIT BOARD	8
REMOVING THE MICRO CIRCUIT BOARD	9
REMOVING A CONNECTOR CIRCUIT BOARD	10
ASSIGNING AN INPUT CONNECTOR BOARD (CHANNEL MUTE ASSIGNMENT)	11-12
INTERNAL LINK OPTIONS	13
ORDERING SPARE PARTS AND ASSEMBLIES	14-15
ORDERING A SPARES KIT	16-18

SECTION B

GL4000-8M/4SM EXPANDER FITTING INSTRUCTIONS	
GL4000 SYS-LINK FITTING INSTRUCTIONS	
GL4000 SYS-LINK APPLICATIONS NOTE	
METER BRIDGE FITTING INSTRUCTIONS	

SECTION C

TECHNICAL BULLETIN	AHTB96010
FRONT PANEL LAYOUT	
REAR PANEL LAYOUT	
BLOCK DIAGRAM - MONO / STEREO INPUT & TALKBACK	
BLOCK DIAGRAM - GROUP / AUX / MATRIX / LR / MONO / 2 TRACK	
BLOCK DIAGRAM - MUTE MICROPROCESSOR	
INTERNAL LAYOUT	
MONO INPUT PCB COMPONENT IDENT	AG2621
MONO INPUT PCB CIRCUIT DIAGRAM	C2621
MONO INPUT CONNECTOR PCB COMPONENT IDENT	AG2622
MONO INPUT CONNECTOR DIAGRAM sheet 1	C2622
MONO INPUT CONNECTOR DIAGRAM sheet 2	C2622
STEREO INPUT PCB COMPONENT IDENT	AG2619
STEREO INPUT PCB CIRCUIT DIAGRAM	C2619
4 MONO 4 STEREO INPUT CONNECTOR PCB COMPONENT IDENT	AG3122
4 MONO 4 STEREO INPUT CONNECTOR CIRCUIT DIAGRAM sheet 1	C3122
4 MONO 4 STEREO INPUT CONNECTOR CIRCUIT DIAGRAM sheet 2	C3122
STEREO INPUT CONNECTOR PCB COMPONENT IDENT	AG3123
STEREO INPUT CONNECTOR CIRCUIT DIAGRAM sheet 1	C3123
STEREO INPUT CONNECTOR CIRCUIT DIAGRAM sheet 2	C3123
4 STEREO 4 MONO INPUT CONNECTOR PCB COMPONENT IDENT	AG2620
4 STEREO 4 MONO INPUT CONNECTOR DIAGRAM sheet 1	C2620
4 STEREO 4 MONO INPUT CONNECTOR DIAGRAM sheet 2	C2620
GROUP LEFT/RIGHT PCB COMPONENT IDENT	AG2623

GROUP LEFT/RIGHT CIRCUIT DIAGRAM sheet 1	C2623
GROUP LEFT/RIGHT CIRCUIT DIAGRAM sheet 2	C2623
MASTER PCB COMPONENT IDENT	AG2626
MASTER CIRCUIT DIAGRAM sheet 1	C2626
MASTER CIRCUIT DIAGRAM sheet 2	C2626
MONO PCB COMPONENT IDENT	AG2625
MONO CIRCUIT DIAGRAM sheet 1	C2625
MONO CIRCUIT DIAGRAM sheet 2	C2625
MASTER CONNECTOR PCB COMPONENT IDENT	AG2627
MASTER CONNECTOR DIAGRAM sheet 1	C2627
MASTER CONNECTOR DIAGRAM sheet 2	C2627
MPU & 3 DIGIT METER PCB COMPONENT IDENT	AG2624+B
MPU CIRCUIT DIAGRAM	C2624
MPU 3 DIGIT METER CIRCUIT DIAGRAM	C2624
SLAVE PCB COMPONENT IDENT	AG2628
SLAVE CIRCUIT DIAGRAM	C2628
GL4000 METER PCB COMPONENT IDENT	AG2092
GL4000 METER CIRCUIT DIAGRAM	C2092
GL4000M METER PCB COMPONENT IDENT	AG3601
GL4000M METER CIRCUIT DIAGRAM	C3601
SYS-LINK PCB COMPONENT IDENT	AG2792
SYS-LINK CIRCUIT DIAGRAM sheet 1	C2792
SYS-LINK CIRCUIT DIAGRAM sheet 2	C2792
SYS-LINK WIRING	M002-211
CONSOLE POWER WIRING	

SECTION D

TECHNICAL DESCRIPTION	2
FUSE RATING & MAINS VOLTAGE SETTING	3
SERVICE ACCESS	
RPS11 ASSEMBLY & WIRING	M002-199A
RPS PCB COMPONENT IDENT	AG0256
RPS11 CIRCUIT DIAGRAM	C002-199

SECTION E

RPSD2 DUAL SUPPLY COMBINER / MONITOR	
RPSD2 FRONT & REAR PANEL LAYOUTS	
RPSD2 SPECIFICATION	
RPSD2 INSTALLATION	
RPSD2 PCB COMPONENT IDENT	AG2255
RPSD2 PCB CIRCUIT DIAGRAM sheet 1	C2255
RPSD2 PCB CIRCUIT DIAGRAM sheet 2	C2255

SECTION A

A

SERVICE PROCEDURES

CAUTION !

TO AVOID DAMAGE TO INTERNAL COMPONENTS BY MISHANDLING AND/OR MISCONNECTION, ONLY TECHNICALLY COMPETENT PERSONNEL SHOULD ATTEMPT SERVICE WORK ON THIS CONSOLE.

TECHNICAL DESCRIPTION

The ALLEN & HEATH *GL4000* is an 8 bus Front-of-House and 10 bus On-stage Monitor mixer. It can also be configured for full 8 track, stereo and mono recording. Standard formats are 24, 32, 40 and 48 channels with optional *SYS-LINK* expander system and *RPSD-2* dual supply combiner / monitor.

CONSTRUCTION

All metal chassis with aluminium extrusions to provide rigidity along the console length. The front panels are non modular with 8 channel input blocks and a master panel incorporating 8 groups, left, right, mono and master sections. The connectors are rear panel mounted with input connectors mounted on circuit boards in blocks of 8. The connectors in the master section are mounted on a single circuit board. The chassis base can easily be removed to gain service access. The soft touch front armrest is incorporated into the front extrusion running along the length of the console.

THE CIRCUIT COMPONENTS

The *GL4000* is manufactured using high performance industry standard linear op-amp, digital and discrete semiconductor circuit devices. In particular the switches and potentiometers have proven to be durable and problem free. When operated correctly the normal performance of the unit introduces no noticeable audio signal degradation.

AUDIO INPUTS AND OUTPUTS

All XLR connector inputs and outputs are balanced. All unbalanced connections are line level 3-pole ¼" jack sockets with low impedance outputs and high impedance inputs. The channel mic and line inputs, and the L-R and Mono outputs are electronically balanced (differential). The outputs can be used with unbalanced equipment by linking the -ve signal to 0V in the cable or input connector. All outputs are low impedance and thus capable of driving several high impedance inputs simultaneously. All inputs and outputs are in phase except for the 2 track Return inputs.

THE PFL/AFL SYSTEM

The console stereo PFL (AFL) switches send pre- (post)-fade signals to the PFL (AFL) mix buses. These signals are switched with 4053 CMOS gates located on the MASTER circuit board (PCB No: AG2626). The supply for the 4053 is $\pm 7.5V$ DC and is derived locally from the $\pm 16V$. The gates are switched when a PFL or AFL switch is selected.

EARTHING THE AUDIO SYSTEM

The console chassis is connected to mains earth via the DC power cable. **FOR SAFETY REASONS NEVER REMOVE THE EARTH WIRE FROM THE POWER SUPPLY UNIT MAINS PLUG.** The console audio 0V is connected to the console chassis. An additional chassis 0V terminal is located on the console rear panel for extra earth bonding if required. Multiple earth paths cause earth (ground) loops which may result in audible hum and interference. These may be avoided by making sure that there is only one path to earth from each piece of equipment, disconnecting audio cable screens at one end if necessary.

INTERCONNECTIONS

Where possible use balanced connections for the CHANNEL inputs, AUX SENDs, L/R and MONO outputs to minimise noise pick-up. Avoid running audio cables near to mains or lighting cables, thyristor dimmer units or power supplies etc. These may cause audible hum and buzz. The use of low impedance sources significantly reduces interference pick-up. Check the cables for correct wiring to avoid problems with phase reversal and unreliable connection. The *GL4000* follows the convention for XLR pin 2 and jack tip = signal hot (+).

Always use balanced cables when connecting to phantom powered microphones.

MAKE SURE THAT THE +48V SWITCHES ARE OFF WHEN THE CHANNEL INPUT XLRs ARE CONNECTED TO NON-PHANTOM POWERED MICROPHONES OR LINE SOURCES.

If ground loops cause problems, connect the cable screen at one end only. Balanced outputs may be connected to unbalanced inputs and vice versa by linking the signal cold (-) to 0V ground.

STANDARD CONSOLES

All consoles supplied with separate RPS11 rack mount power unit.

Optional RPSD dual supply combiner / monitor.

Optional VU meterpod and optional SYS-LINK expander system.

GL4000-824S GL4000M-824n

M24 VU METER BRIDGE			
CHANS 1-8	CHANS 9-16	MASTER	CHANS 17-24

GL4000-832S GL4000M-832n

M32 VU METER BRIDGE				
CHANS 1-8	CHANS 9-16	MASTER	CHANS 17-24	CHANS 25-32

GL4000-840S GL4000M-840n

M40 VU METER BRIDGE					
CHANS 1-8	CHANS 9-16	CHANS 17-24	MASTER	CHANS 25-32	CHANS 33-40

GL4000-848S GL4000M-848n

M48 VU METER BRIDGE						
CHANS 1-8	CHANS 9-16	CHANS 17-24	MASTER	CHANS 25-32	CHANS 33-40	CHANS 41-48

GL4000-8M

8x MONO CHANS

GL4000-4SM

4x MONO 4x STEREO CHANS

GL4000 DIMENSIONS (consoles up to serial number 403420)

The diagrams below give the dimensions for flightcasing the console and power supply unit.

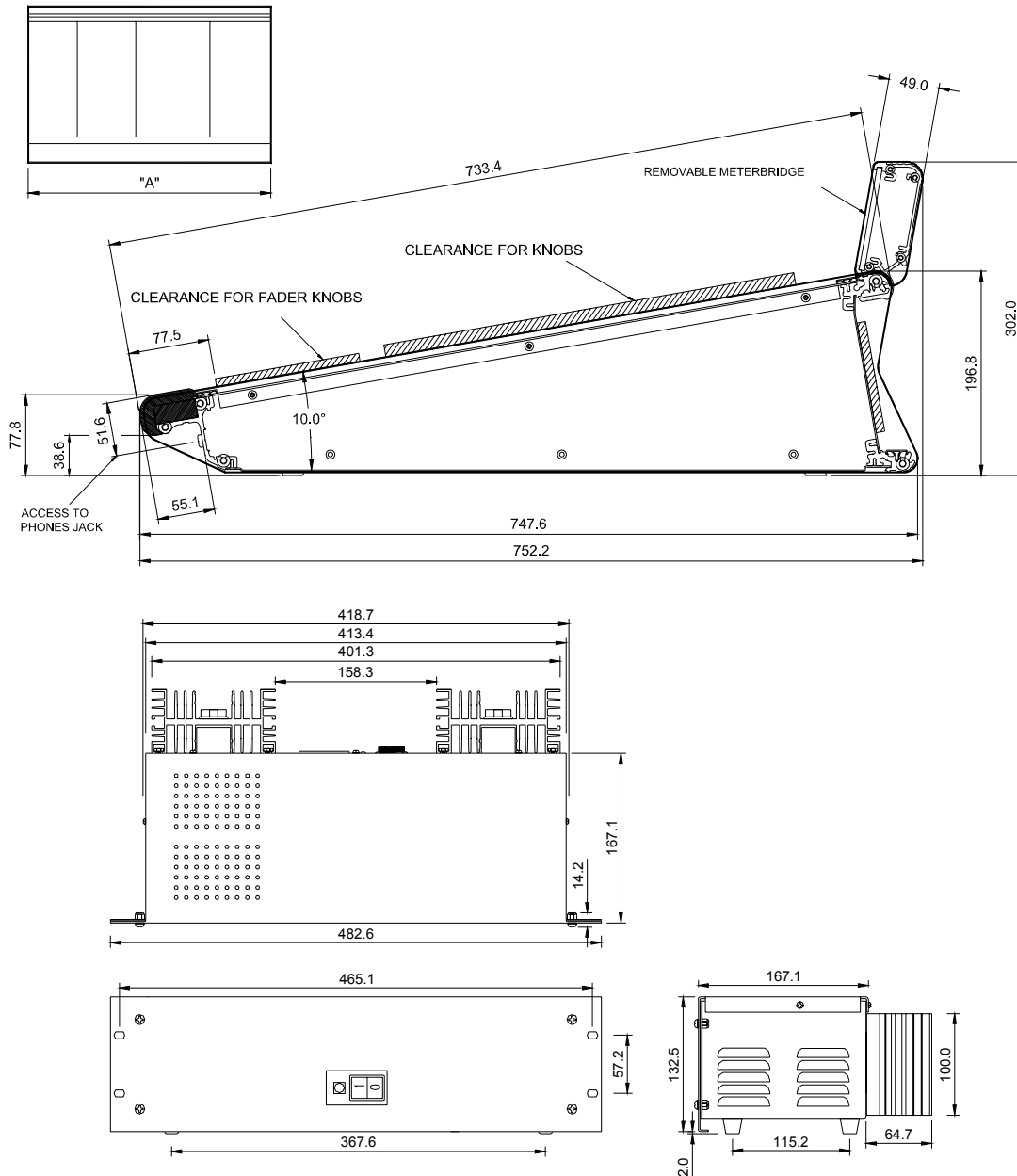

The RPS11 is supplied with a 2m mains lead with a moulded mains plug and IEC socket. A 3m DC output cable is also supplied to connect the RPS11 to the GL4000.

MECHANICAL DETAILS

UNPACKED	Width	Depth	Height	Wt
GL4000-824	1166	748	197	43 kg
GL4000-832	1421	748	197	52 kg
GL4000-840	1676	748	197	61 kg
GL4000-848	1931	748	197	70 kg
GL4000-8M	255	748	197	9 kg
Meterpod	1154-1664	+56	+106	
RPS11	483 (19")	232	135 (3U)	10 kg
RPSD2	483 (19")	180	45 (1U)	4.5kg

PACKED	Width	Depth	Height	Wt
GL4000-824	1702	900	390	76 kg
GL4000-832	1702	900	390	84 kg
GL4000-840	1950	900	390	92 kg
GL4000-848	2205	900	390	120 kg
GL4000-8M	480	830	260	12 kg
Meterpod	1290-1800	130	230	6-8 kg
RPS11	575	295	175	11 kg
RPSD2	570	340	75	6 kg

GL4000M DIMENSIONS (consoles from serial number 403421)

The diagrams below give the dimensions for flightcasing the console and power supply unit.

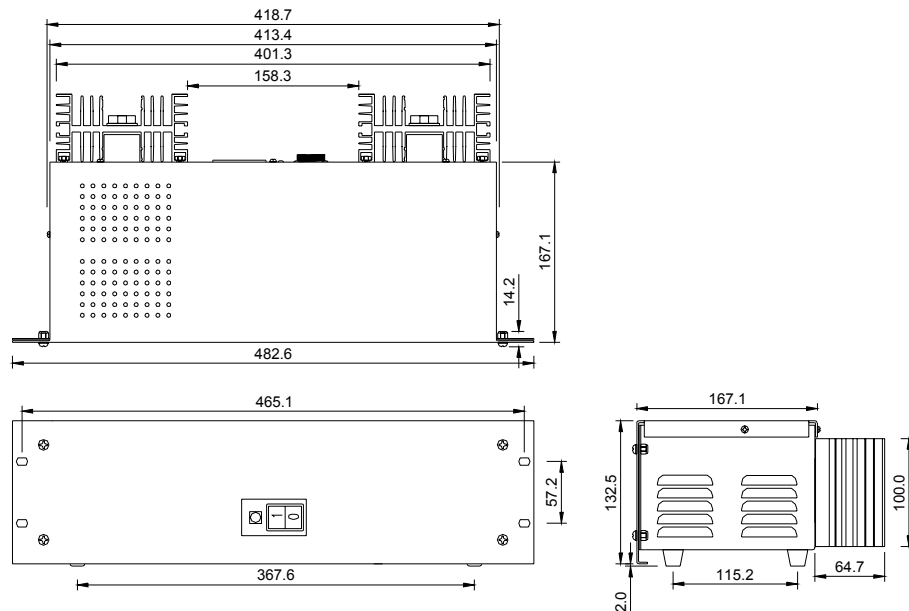
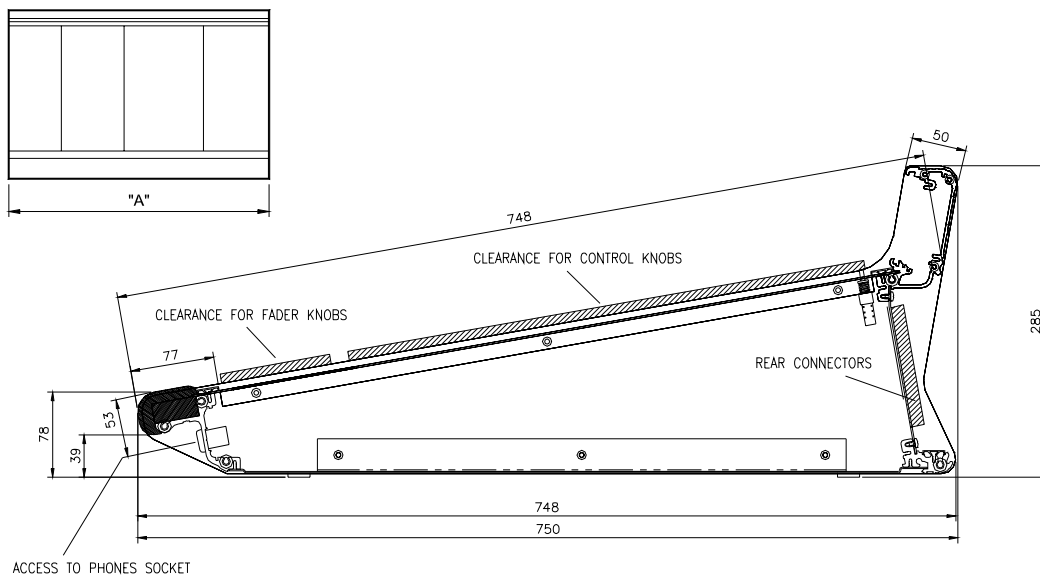

The RPS11 is supplied with a 2m mains lead with a moulded mains plug and IEC socket. A 3m DC output cable is also supplied to connect the RPS11 to the GL4000.

MECHANICAL DETAILS

UNPACKED	Width	Depth	Height	Wt
GL4000M-824	1166	748	285	47 kg
GL4000M-832	1421	748	285	57 kg
GL4000M-840	1676	748	285	67 kg
GL4000M-848	1931	748	285	77 kg
GL4000-8M	255	748	285	9 kg
RPS11	483 (19")	232	135 (3U)	10 kg
RPSD2	483 (19")	180	45 (1U)	4.5kg

PACKED	Width	Depth	Height	Wt
GL4000M-824	1702	900	390	82 kg
GL4000M-832	1702	900	390	91 kg
GL4000M-840	1950	900	390	100 kg
GL4000M-848	1931	900	390	129 kg
GL4000-8M	480	830	260	12 kg
RPS11	575	295	175	11 kg
RPSD2	570	340	75	6 kg

SPECIFICATIONS

0dBu=0.775 Vrms
1.23 V
0dBV=1 Vrms
0VU meter reading = +4dBu at XLR outputs

Reference for high level equipment +4dBu =
Reference for low level equipment -10dBV = 310 mV

Input Gain

Mic/Line Input	+6dB to +60dB variable
Mic/Line + Pad	-14dB to +40dB variable
Line Input	-14dB to +40dB variable
Stereo Line Input	off to +10dB variable
2-track Return	off to +10dB variable

Maximum Output Level

Main Outputs	+27dBu into load of >600 ohm
Jack Outputs	+21dBu into load of >2K ohm
Internal headroom	+21dB

Frequency Response

Measured 20Hz to 20kHz ref 1kHz

Mic to mix (+40dB)	+0/-0.5dB
Line to mix (0dB)	+0/-0.5dB

Distortion

THD + noise measured @ 1kHz +20dBu

Mic to mix (+40dB)	0.006%
Line to mix (0dB)	0.006%

Crosstalk

Referred to driven channel @ 1kHz

Channel to channel	> 100dB
Mute shutoff	> 85dB
Fader shutoff	> 90dB

Noise Performance

Measured rms 22Hz to 22kHz bandwidth

Mic EIN	-128dB 150 ohm source
Line pre-amp (0dB)	< -91dBu
Residual output noise	< -98dBu (-102dB S/N)
Mix noise, nothing routed	< -87dBu (-91dB S/N)
Mix noise, 24 channels routed	< -81dBu (-85dB S/N)

Metering

Input meters	4 segment LED (signal, 0, +6, peak)
Mix meters	4 segment LED (signal, 0, +6, peak)
Output meters	12 segment LED
LED meter response	peak reading
Peak indicators	on 5dB before clipping
Signal indicators	on -20dBu
VU meterpod	Illuminated VU moving coil meters

CONNECTIONS

INPUTS:

MIC/LINE IN	XLR	pin 2 hot, 3 cold	balanced	2 kohms	variable -60 to -6dBu
MIC/LINE IN +PAD	XLR	pin 2 hot, 3 cold	balanced	10 kohms	variable -40 to +14dBu
LINE IN	1/4" JACK	tip hot, ring cold	balanced	10 kohms	variable -40 to +14dBu
STEREO LINE IN	1/4" JACK	tip hot, ring cold	balanced	10 kohms	-10dBu or +14dBu
CHANNEL INSERTS	1/4" JACK	tip hot, ring cold	balanced	10 kohms	0dBu
OUTPUT INSERT RET	1/4" JACK	tip hot, ring cold	balanced	10 kohms	-2dBu
2-TRACK INPUT	1/4" JACK		unbalanced	10 kohms	variable -10dBV

OUTPUTS:

L, R, MONO OUT,	XLR	pin 2 hot, 3 cold	balanced	75 ohms	+4dBu
GROUP OUT,	XLR	pin 2 hot, 3 cold	balanced	75 ohms	+4dBu
AUX OUT,	XLR	pin 2 hot, 3 cold	balanced	75 ohms	+4dBu
MATRIX A, B, C, D	1/4" JACK	tip hot, ring cold	impedance bal	50 ohms	+4dBu
DIRECT OUT	1/4" JACK	tip hot, ring cold	impedance bal	50 ohms	0dBu or variable
MONITOR	1/4" JACK	tip hot,	unbalanced	2 kohms	0dBu variable
2-TRACK OUTPUTS	1/4" JACK	tip hot,	unbalanced		0dBu variable
HEADPHONES OUT	1/4" JACK	tip L, ring R			for stereo headphones 8 to 400 ohms
(2 SOCKETS)	1/4" JACK	tip L, ring R			for stereo headphones 8 to 400 ohms

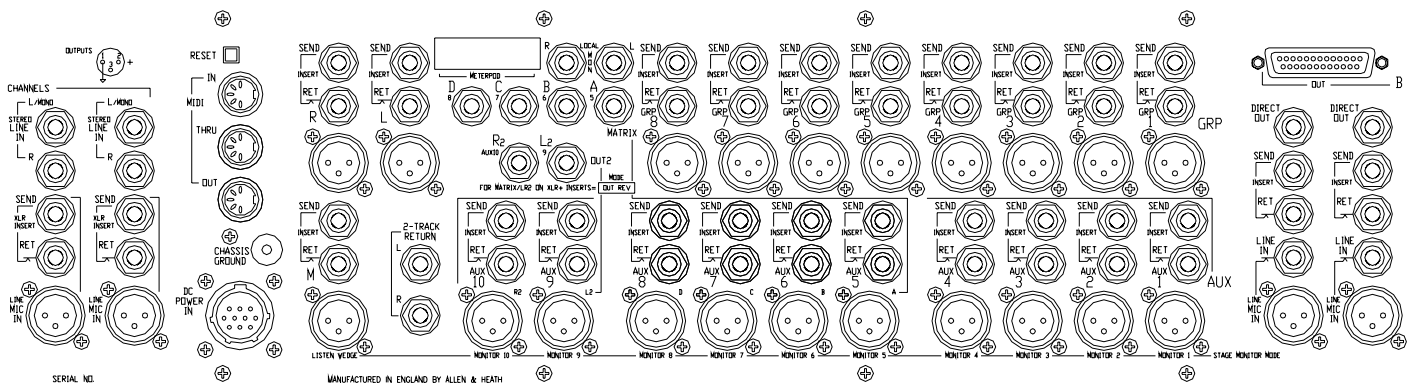
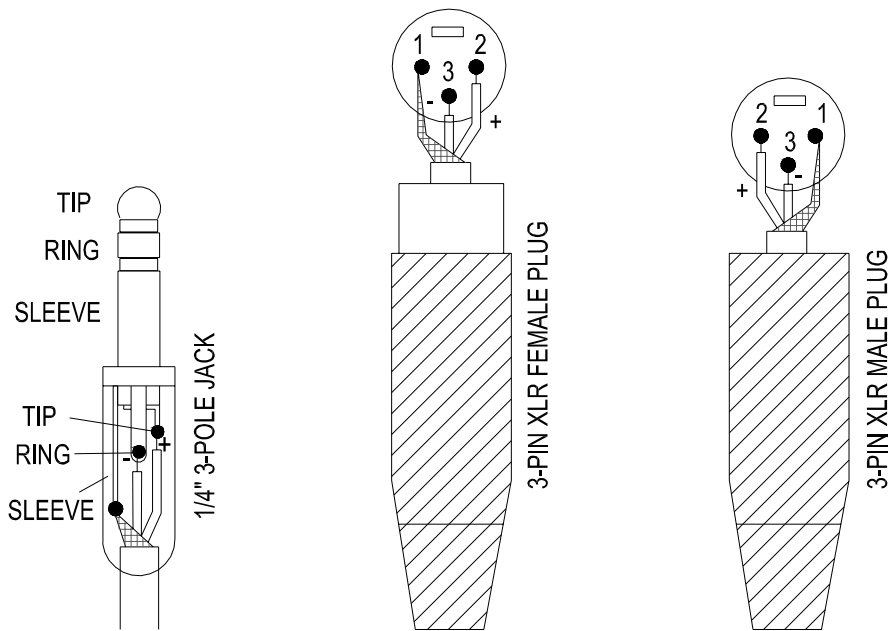

GL4000 REAR PANEL CONNECTORS

REMOVING A CHANNEL, GROUP, LEFT / RIGHT, MONO or MASTER

CIRCUIT BOARD ASSEMBLY

Before beginning any service work, remove all power to the console and disconnect any signal cables where necessary. Service work is best carried out with the console inverted or positioned upright on its rear with the connectors removed. Ensure adequate lighting and use the correct tools. Access to the CHANNEL, GROUP, LEFT/RIGHT, MONO or MASTER circuit board is as follows:

- 1.) Before inverting the console, pull off the knobs and remove the pot nuts from the circuit assembly to be removed. The switch caps can remain in place.
- 2.) With the console inverted or on its rear, remove the base and identify the circuit board to be removed.
- 3.) Disconnect the harness (A) plugged into the connectors mounted along the edge of the circuit boards..
- 4.) Carefully unplug the flat flexible cable (B) plugged into the circuit board assembly to be removed.

WHEN REMOVING A CHANNEL CIRCUIT BOARD ASSEMBLY

Cut the Earth buss wire (G) on each side of the channel circuit board to be removed. Remember to resolder the Earth buss wire (G) wire when channel circuit board has been replaced.

WHEN REMOVING A GROUP, LEFT/RIGHT or MONO CIRCUIT BOARD ASSEMBLY

The SLAVE circuit board assembly mounted across the GROUP, LEFT, RIGHT and MONO circuit board assemblies in the master section of the console will have to be removed along with harness (D).

ALSO WHEN REMOVING THE RIGHT CIRCUIT BOARD ASSEMBLY

Harness (E) will have to be disconnected from the MONO circuit board along with harness (D).

ALSO WHEN REMOVING THE MONO CIRCUIT BOARD ASSEMBLY

Harness (E) and the flexible flat cable (F) will have to be disconnected from the MONO circuit board along with harness (D). Take care not to stretch the DC power harness and fader wires still connected to the circuit board assembly.

WHEN REMOVING THE MASTER CIRCUIT BOARD ASSEMBLY

The SLAVE circuit board assembly can remain in place, only harness (C) requires removal from both the SLAVE and MASTER circuit board assemblies. The flexible flat cable, (F) and the green wire soldered onto the trackside of the circuit board will also need to be disconnected. Take care not to stretch the headphone socket wires that are still connected.

- 5.) The circuit board can now be removed, take care not to stretch the fader wires that are still connected.

When all service work is complete, remove all debris such as solder, component legs and wire clippings from inside the console and check your work carefully before reassembly. To refit the circuit assembly follow the above procedure in reverse order. Make sure all harnesses are correctly aligned and plugged on. Test for correct operation.

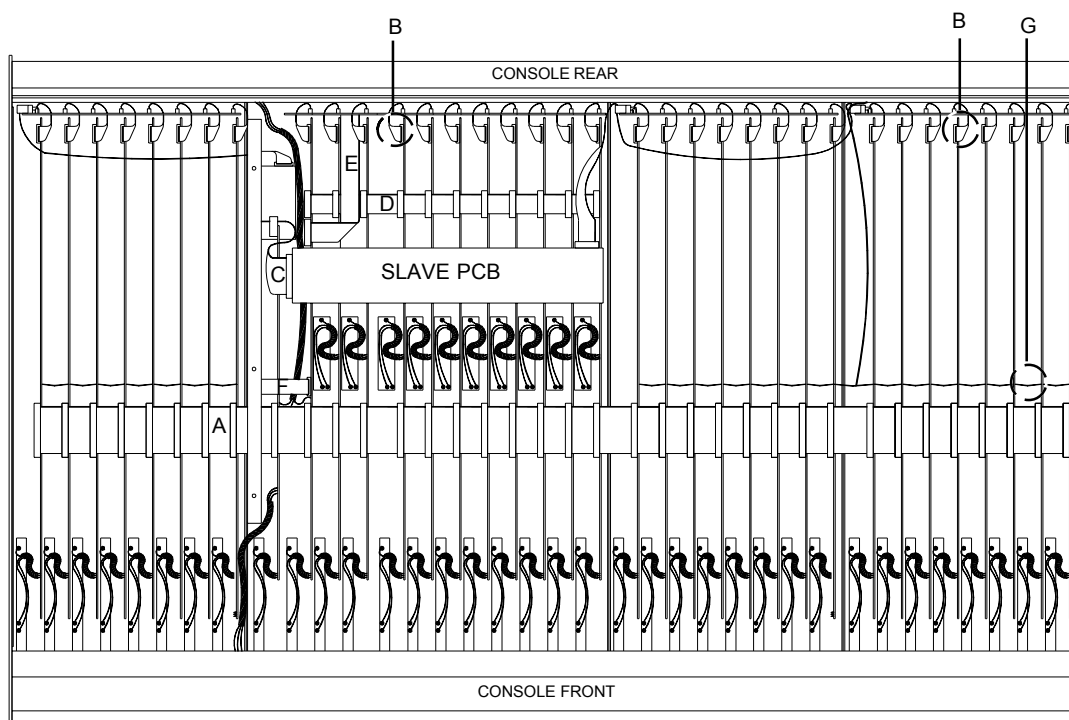

GL4000-824 inverted with the base cover removed.

REMOVING THE MICRO CIRCUIT BOARD ASSEMBLY

Before beginning any service work remove all power to the console and disconnect any signal cables where necessary. Service work is best carried out with the console inverted or positioned upright on its rear with the connectors removed. Ensure adequate lighting and use the correct tools. Access to the MICRO circuit board is as follows:

- 1.) Working from the rear of the console, remove the screw (A) near to the CHASSIS GROUND terminal on the rear connector panel.
- 2.) With the console inverted or on its rear, remove the base, identify the MICRO circuit board assembly and then disconnect the ribbon harnesses plugged into the connectors mounted along the edge of the circuit board. Also disconnect the flat flexible cable.
- 3.) The circuit board can now be removed by first squeezing the tops of the mounting pillars and lifting the circuit board clear of the pillars. Then carefully manoeuvre the circuit board assembly into a suitable position to carry out service work. Take care not to stretch the wires soldered onto the circuit board

When all service work is complete, remove all debris such as solder, component legs and wire clippings from inside the console and check your work carefully before reassembly. To refit the MICRO circuit board assembly follow the above procedure in reverse order. Make sure all harnesses are correctly aligned and plugged on. Test for correct operation.

rear panel view

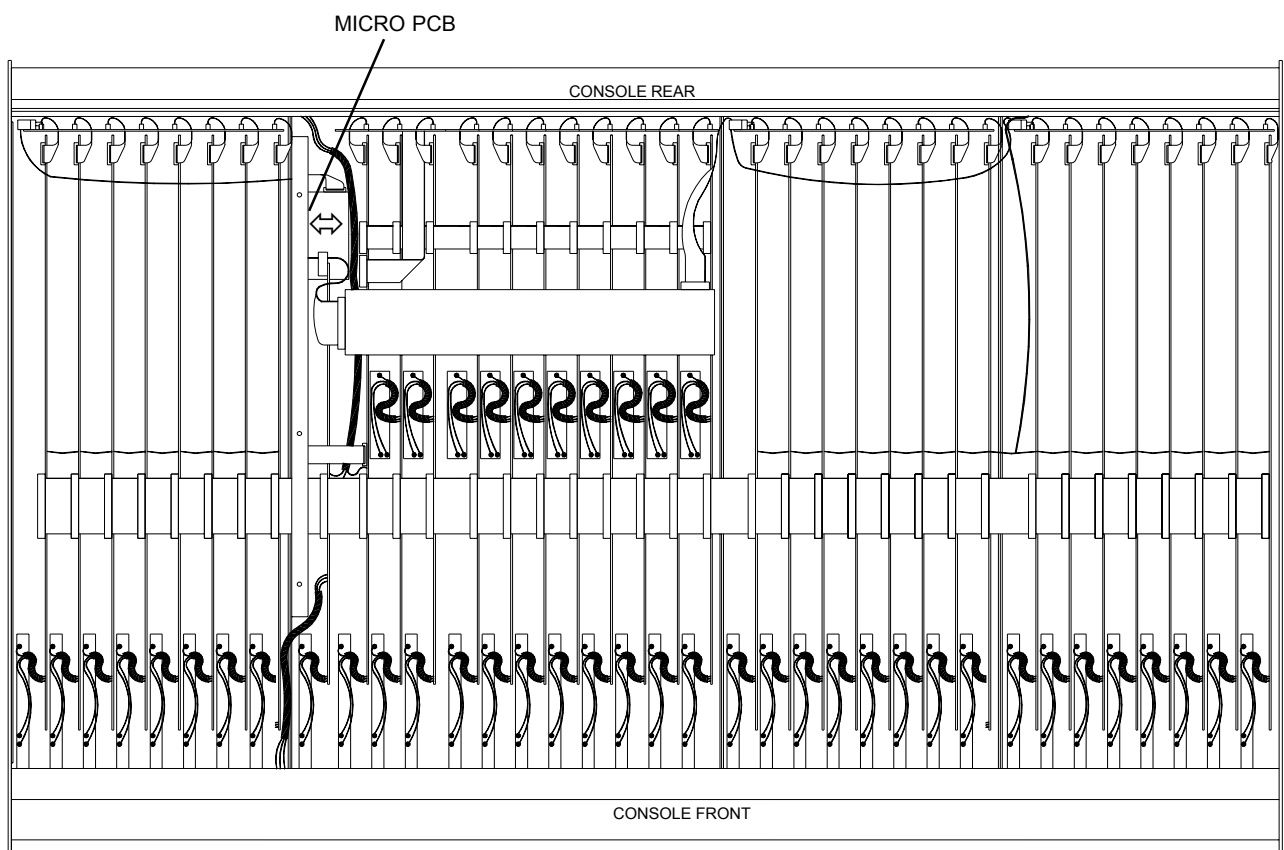
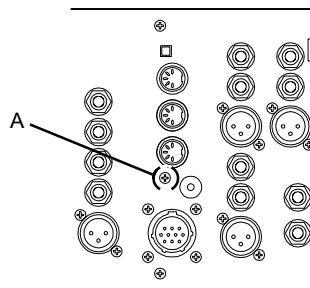

GL4000-824 inverted with the base cover removed.

REMOVING A CONNECTOR CIRCUIT BOARD ASSEMBLY

Before beginning any service work, remove all power to the console and disconnect any signal cables where necessary. Service work is best carried out with the console inverted on a clean work surface suitably covered to protect the console cosmetics. Ensure adequate lighting and use the correct tools. Access to the connector circuit boards is as follows:

- 1.) With the console inverted, remove the base. Identify which connector board is to be removed and then disconnect the flat flexible cables and ribbon harnesses to it.
- 2.) Working from the rear of the console remove the screws (A) fixing the XLR connectors to the panel but do not remove the screws (B) fixing the panel to the chassis. Remove the 12mm hex jack nuts (C) with a suitable tool.
- 3.) The circuit board assembly can now be removed from the rear panel.

NOTE: if removing a master connector circuit board assembly, unscrew the green earth wires connecting the circuit board assembly to the chassis extrusion before lifting the circuit board clear.

When all service work is complete, remove all debris such as solder, component legs and wire clippings from inside the console and check your work carefully before reassembly. To refit the connector circuit assembly follow the above procedure in reverse order. Make sure all harnesses are correctly aligned and plugged on. Test for correct operation.

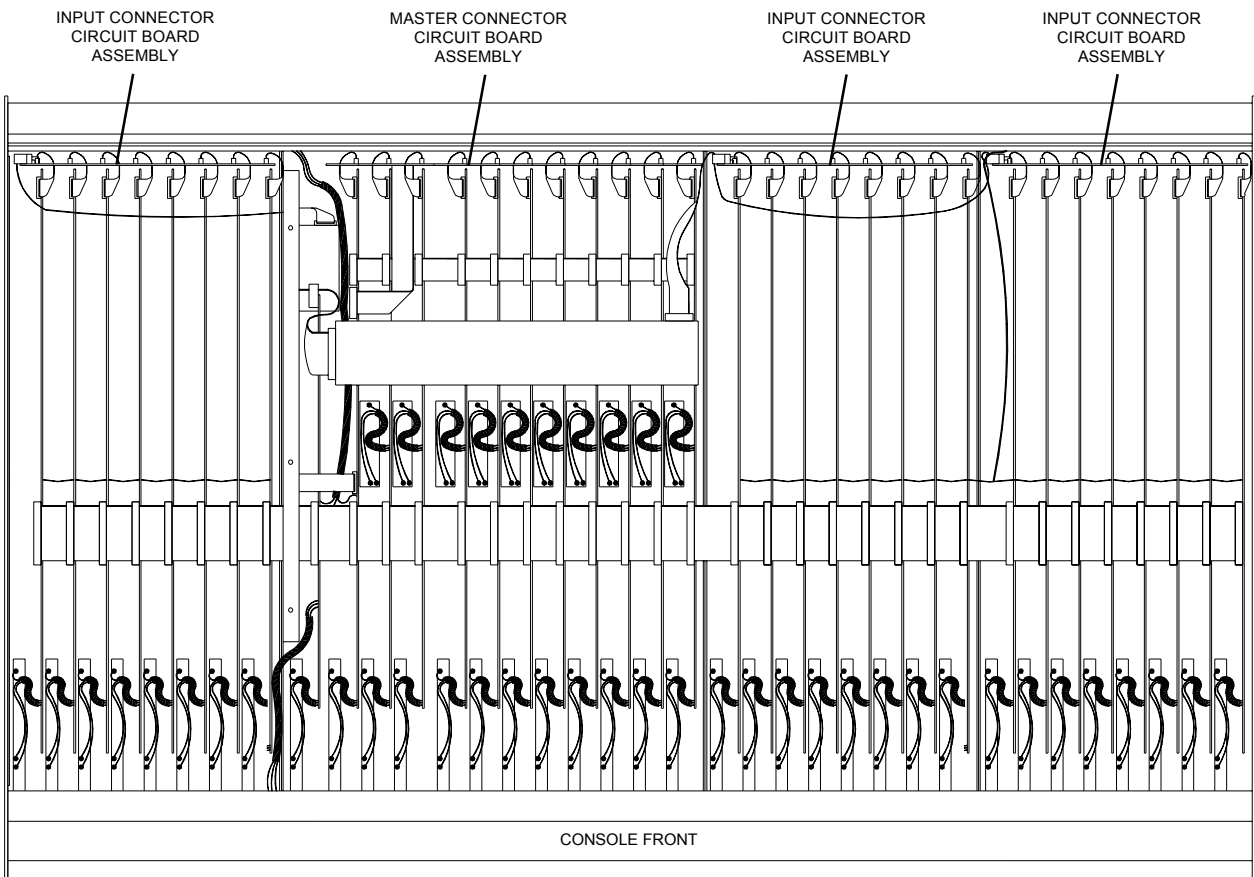

GL4000-824 inverted with the base cover removed.

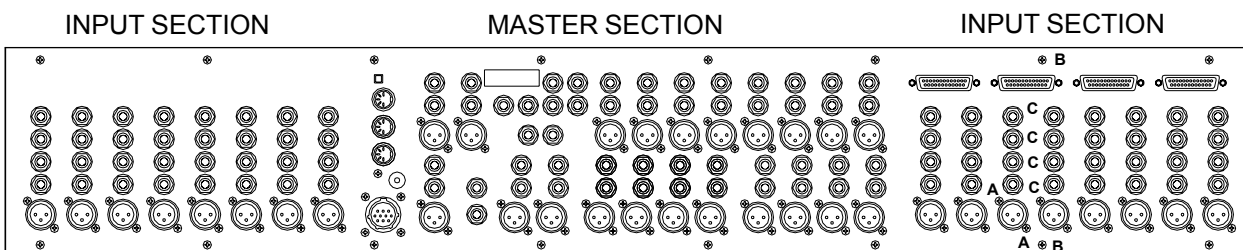

GL4000 Rear Panel View.

ASSIGNING AN INPUT CONNECTOR CIRCUIT BOARD ASSEMBLY

Before fitting a replacement input connector circuit board assembly, check the assignment of the channel mutes is correct. If possible check the circuit board assembly with the one that has been removed.

The assignment links are zero ohm (0R) resistors and are located near to the ribbon harness connector on the input connector board.

The channel mute assignment is set by soldering a 0R resistor into one of four locations. see below

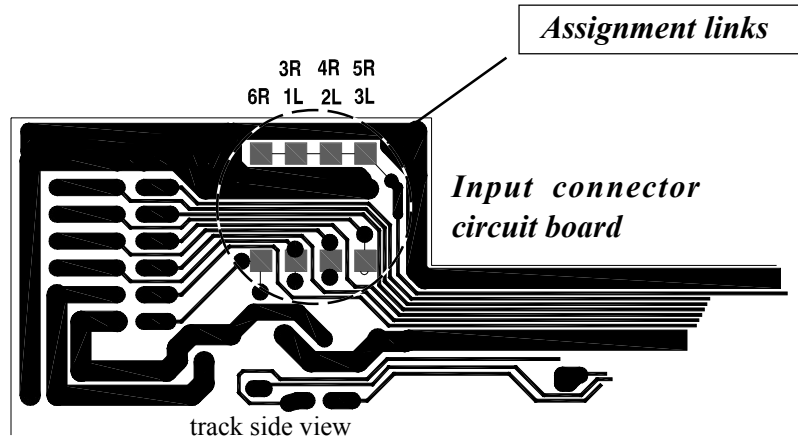

The diagrams below show the channel mute link assignments for the input connector circuit board assemblies for each console format.

Remember when adding an expander to the console the assignment of the links in the console may also require reassigning. Refer to the expander fitting instructions (AP2794).

GL4000-824S GL4000M-824n

(Stereo configurations differ)

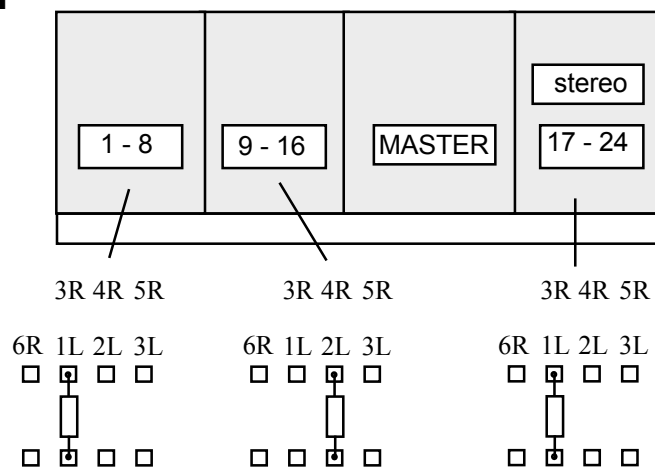

GL4000-832S

GL4000M-832n

(Stereo configurations differ)

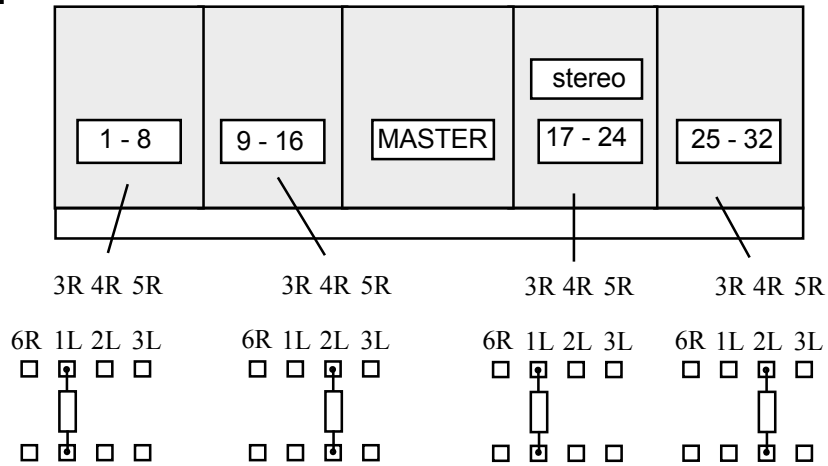

GL4000-840S

GL4000M-840n

(Stereo configurations differ)

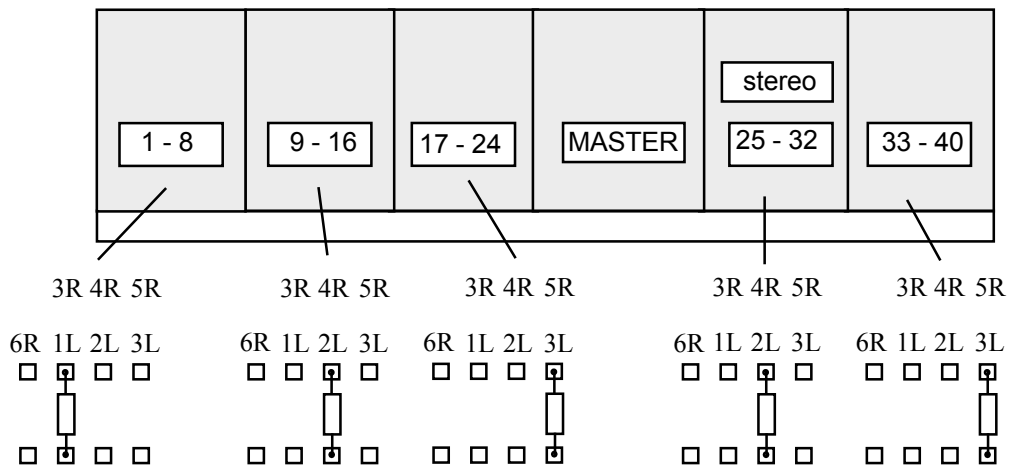

GL4000-848S

GL4000M-848n

(Stereo configurations differ)

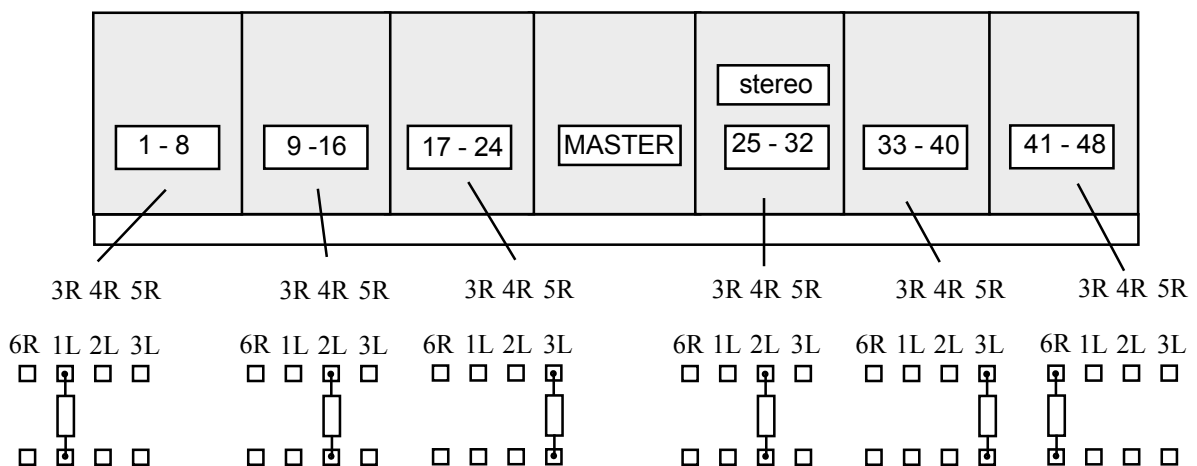

INTERNAL LINK OPTIONS

The **GL4000** is configured to satisfy most of the applications that are likely be encountered. However, the following internal link options are offered for those applications that may require alternative settings. These options require access to the internal circuit assemblies and resoldering of circuit board links. This work should be carried out by technically competent personnel. Further information is available in the separately available service manual and from your Allen & Heath agent.

MONO CHANNEL

Set individual aux sends to be permanently pre-fader or post-fader rather than switched. Re-position wire links. Set the pre-fade aux sends to be pre-EQ rather than post-EQ. Re-position a wire link. Set the pre-fade aux links to be pre-mute rather than post-mute. Re-position a wire link. Disable +48V phantom power so that the panel switch has no effect. Cut out the wire link.

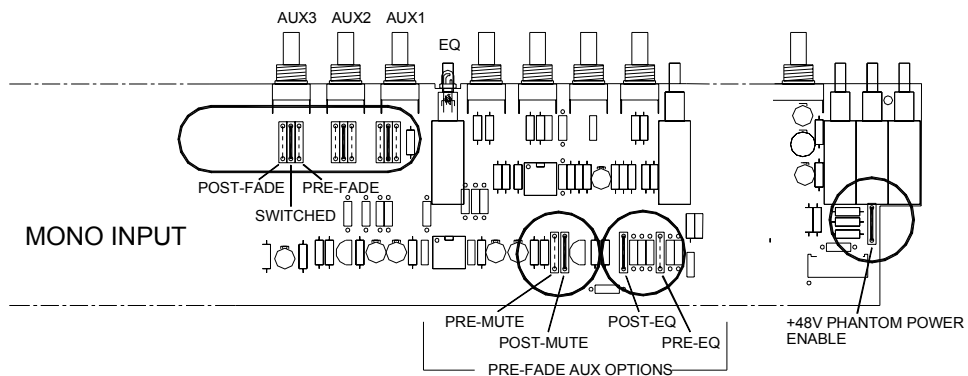

STEREO CHANNEL

Set individual aux sends to be permanently pre-fader or post-fader rather than switched. Re-position wire links. Set the pre-fade aux sends to be pre-EQ rather than post-EQ. Re-position 2 wire links. Set the pre-fade aux links to be pre-mute rather than post-mute. Re-position a wire link. Disable +48V phantom power so that the panel switch has no effect. Cut out the wire link.

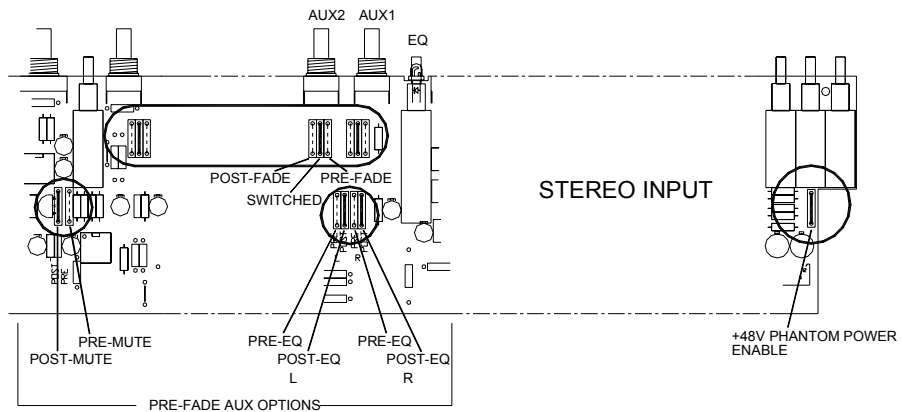

TALKBACK MIC +48V

Disable +48V phantom power from the TB mic input XLR. Remove a jumper link (fit on 1 pin to keep in console).

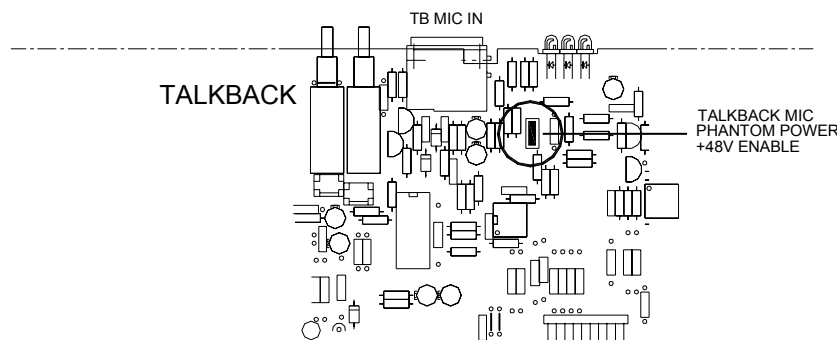

ORDERING SPARE PARTS

ORDERING A CONSOLE

To order a new console please specify the model number required. Refer to the section: Standard Consoles for more detail

MODEL	DESCRIPTION	ORDERCODE
<i>GL4000M-824A/B/C/D</i>	24 Input channels with integral meterbridge + Power Supply	GL4000M-824n
<i>GL4000M-832A/B/C/D/E</i>	28 Input channels with integral meterbridge + Power Supply	GL4000M-832n
<i>GL4000M-840A/B/C/D</i>	36 Input channels with integral meterbridge + Power Supply	GL4000M-840n
<i>GL4000M-848A/B/C/D/E/F</i>	44 Input channels with integral meterbridge + Power Supply	GL4000M-848n

ORDERING AN OPTION

To order an option please specify the model number required:

<i>GL4000-M24</i>	Meterpod to fit 24 channel console	GL4000-M24
<i>GL4000-M32</i>	Meterpod to fit 32 channel console	GL4000-M32
<i>GL4000-M40</i>	Meterpod to fit 40 channel console	GL4000-M40
<i>GL4000-M48</i>	Meterpod to fit 48 channel console	GL4000-M48
<i>GL4000-8M</i>	8 Mono Input channel expander	GL4000-8M
<i>GL4000-4SM</i>	4 Mono + 4 Stereo Input channel expander	GL4000-4SM
<i>GL4000-SL1</i>	GL4000SYS-LINKkit	GL4000-SL1
<i>RPSD2</i>	Dual supply Combiner / Monitor	RPSD-2

MANUALS AND SUPPORT DOCUMENTATION

DESCRIPTION	ORDER CODE
<i>GL4000</i> Brochure	AP2641
<i>GL4000</i> User Guide	AP2642
<i>GL4000</i> Service Manual	AP2640
<i>GL4000</i> Meterpod Fitting Instructions	AP2126
<i>GL4000</i> SYS-LINK Fitting Instructions	AP2786
<i>GL4000</i> SYS-LINK Application Note	AP2787
<i>GL4000-8M / 4SM</i> Fitting Instructions	AP2794
<i>RPS11</i> User / Installation Guide	AP2725
<i>RPSD-2 & RPSD</i> User / Installation Guide	AP2263

SOFTWARE EPROM

To order a replacement EPROM, please contact ALLEN & HEATH and notify us of your console serial number, its present EPROM version and code number and reason for the replacement.

GL4000 software

SERVICE TOOLS

The tools required to service the *GL4000* are standard to an electronics service workshop and are easily obtainable. The following items are necessary for disassembly and service access:

4mm Hexagon (Allen) key (M6 side trim)	AT0033
1-point Crosshead screwdriver (M3, 4AB)	AT0004
2-point Crosshead screwdriver (M4, 6AB)	AT0004
11mm Nutdriver (potentiometer nuts, headphone socket nuts)	
12mm Nutdriver (jack nuts)	
Torx-headed screw drivers	

ORDERING AN ASSEMBLY

The following assemblies are supplied fully tested. Please note that several of these need to be assigned according to their position in the console. This is done by soldering wire links or assignment pads. It is best to check the assignment settings of the assembly you are replacing before removing it from the console. Please quote the description and order code for the part required.

Printed circuit (PCB) assemblies:

Mono Input Connector IN-8M CONN PCB assembly*	002-161
Mono Input PCB assembly	002-160
Stereo Input Connector IN-4SM CONN PCB assembly*	002-196
Stereo Input PCB assembly	002-195
Group 1-4 PCB assembly*+	002-162
Group 5-8 PCB assembly*+	002-163
Left / Right PCB assembly*+	002-197
Master PCB assembly	002-165
Master connector PCB assembly	002-166
Mono PCB assembly	002-164
Slave PCB assembly	002-167
MPU & 3 digit display PCB assembly	002-198
RPS11 PCB assembly	002-047
GL4000 Meterpod PCB assembly LEFT	002-039
GL4000 Meterpod PCB assembly RIGHT	002-040
GL4000M Meterpod PCB assembly LEFT	002-464
GL4000M Meterpod PCB assembly RIGHT	002-465

* Requires assignment +Quote Group Number, Left or Right

IDC connector harnesses:

GL4000-824/32/40&48	40 way Main harness	AL2636
GL4000-824 & 832	16 way left hand harness	AL2763
GL4000-840 & 848	16 way left hand harness	AL2764
GL4000-816 & 824	16 way right hand harness	AL2760
GL4000-832 & 840	16 way right hand harness	AL2761
GL4000-848	16 way right hand harness	AL2762
GL4000 (all formats)	16 way Master harness	AL2759
GL4000 (all formats)	16 way Meter harness	AL2733
GL4000 (all formats)	26 way MPU harness	AL2732

THE CHASSIS TRIM

GL4000 (all formats)	Left & Right Chassis side trims	AA2089L/R
GL4000M (all formats)	Left & Right Chassis side trims	AA3584-L/R
	Write-on strip 10'	AK0327
GL4000-824 & 832	Ident strip CHAN 1-16	AK2637
GL4000-824 & 832	Ident strip CHAN 1-16 Rear	AK3112
GL4000-840 & 848	Ident strip CHAN 1-24	AK2638
GL4000-840 & 848	Ident strip CHAN 1-24 Rear	AK3113
GL4000-824 & 832	Ident strip GRP 1- CHAN 32	AK2639
GL4000-824 & 832	Ident strip GRP 1- CHAN 32 Rear	AK3114
GL4000-840 & 848	Ident strip GRP 1- CHAN 40	AK2703
GL4000-840 & 848	Ident strip GRP 1- CHAN 40 Rear	AK3115
GL4000-848	Ident strip CHAN 41-48	AK2704
GL4000-848	Ident strip CHAN 41-48 Rear	AK3116
GL4000 Meterpod	Left & Right Meterpod side trims	AA2090L/R

ORDERING A SPARES KIT

It is recommended that the spares kit order code **002-177** is held and maintained by the service agent to enable in-field service repairs to the **GL4000** independent of the ALLEN & HEATH factory. If you are an existing ALLEN & HEATH service agent who already stocks the spares kit for the ALLEN & HEATH **GL4**, you may already stock some of the common parts. A TOP-UP kit **002-178** is available which provides just the parts unique to the **GL4000** range. Commonly available items such as resistors, capacitors, tools and soldering equipment are not included. The contents of the kit is listed below and is supplied in a cabinet of drawers. Individual spare parts may be ordered. Please quote the description and order code for the part required.

- A - GL4000 STANDARD SPARES KIT**
- B - GL4 TO GL4000 TOP-UP KIT**

DESCRIPTION	ORDER CODE	A QTY	B QTY
-------------	------------	----------	----------

Fixings:

Screw 4AB x 5/16" Pan Pozi Black	AB0057	10	-
Screw 4AB x 5/16" CSK Pozi Black	AB0059	10	-
Screw 6B x 5/16" Pan Pozi Black	AB2084	10	-
Screw 8B x 5/16" CSK Pozi Black	AB2085	10	-
Screw 6B x 1/4" CSK Pozi zinc	AB2083	10	-
Screw 6B x 3/8" CSK Pozi zinc	AB2082	10	-
Screw M6 x 20mm CSK Allen Black	AB0310	5	-
Screw M3 x 5mm CSK Pozi Black	AB0070	10	-
Screw M3 x 8mm Pan Pozi Black	AB0073	10	-
Screw M3 x 8mm CSK Pozi Black	AB0074	5	-
Nylock Nut M3	AB0102	5	-
Fixing for D type connector	AB2189	10	-
Joint Block	AB0253	2	-
Plastic pillar snap-in	AB2233	4	4

Knobs and caps:

Knob Yellow & Grey 11mm D	AJ2079	10	-
Knob Dark Grey & Grey 11mm D	AJ2078	10	-
Knob Green & Grey 11mm D	AJ2077	10	-
Knob Blue & Grey 11mm D	AJ2075	10	-
Knob Brown & Grey 11mm D	AJ2080	10	-
Knob Red & Grey 11mm D	AJ2074	10	-
Knob Pale blue & Grey 11mm D	AJ2076	10	10
Fader Knob 11mm White+Black line Jungpoon*	AJ2231	10	10
Fader Knob 11mm Red+White line Jungpoon*	AJ2230	5	5
Fader Knob 11mm Yellow+Black line Jungpoon*	AJ2232	5	5
Fader Knob 11mm Blue+White line Jungpoon*	AJ2663	5	5
Fader Knob 11mm White+Black line Alps*	AJ8078	10	-
Fader Knob 11mm Red+Black line Alps*	AJ8079	5	-
Fader Knob 11mm Yellow+Black line Alps*	AJ8080	5	-
Fader Knob 11mm Blue+Black line Alps*	AJ8081	5	-
Button 5.5mm Square Grey	AJ0363	10	-
Button 5.5mm Square Red	AJ0364	10	-
Button 5.5mm Square White	AJ0373	10	-
Button 10x5mm Rectangular Grey	AJ0093	10	-
Button 10x5mm Rectangular White	AJ0094	10	-
Button 10x5mm Rectangular Black	AJ0096	5	-
Button large illuminated white	AJ8107	10	10

*TO FIND OUT IF JUNGPOON OR ALPS KFADERS/FADER KNOBS CHECK CONSOLE SERIAL NUMBER WITH FACTORY

Faders, Potentiometers, switches, and connectors:

10KA fader 100mm Jungpoon*	AI2665	5	5
10KA x 2 fader 100mm (stereo) Jungpoon*	AI2664	2	2
10KA fader 100mm Alps K*	AI8109	5	5
10KA x 2 fader 100mm (stereo) Alps K*	AI8110	2	2
10KA fader 60mm	AI8054	5	-
20KK (203K)	AI8003	5	-
20KB x 2 (203B 14mm wide)	AI8006	3	3
20KK x 2 (203K 14mm wide)	AI8007	5	-
20KB (203B) centre click	AI8004	5	-
20KB x 2 (203B 14mm wide) centre click	AI8064	3	-
10KC x 2 (103C 14mm wide)	AI0150	5	-
10KAC x 2 (103AC 14mm wide)	AI8008	5	-
200KC x 2 (204C)	AI8005	5	-
200KC x 2 (204C 14mm wide)	AI8009	5	-
Pot Nut 9mm	AB8050	10	-
Switch 2PCO Latching	AL0162	5	-
Switch 2PCO Momentary	AL0374	5	-
Switch 4PCO Latching	AL0333	5	-
Switch 6PCO Latching	AL0354	2	2
Jack Socket Vertical PCB Mount + Hex nut	AL8082	5	-
Jack Socket Headphone	AL0328	1	-
XLR 3 Pin Female Vertical PCB Mount	AL8074	5	-
XLR 3 Pin Male Vertical PCB Mount	AL8077	5	-
XLR 4 Pin Female Chassis Mount	AL8104	-	-

* TO FIND OUT IF JUNGPOON OR ALPS K FADERS/FADER KNOBS CHECK CONSOLE SERIAL NUMBER WITH FACTORY

LEDs and Semiconductors:

LED 5mm T1¾ Red	AE0001	2	2
LED 3mm T1 Green	AE0085	5	-
LED 3mm T1 Yellow	AE0084	5	-
LED 3mm T1 Red	AE0086	5	-
LED Bar 4way 2Gn+1Yel+1Rd	AE2702	2	2
LED Bar 12way 8Gn+3Yel+1Rd	AE2701	2	2
Transistor 2SB737 PNP	AE8069	5	-
Transistor BC549 NPN	AE0020	3	-
Transistor 2N4403 PNP	AE0273	5	-
Transistor BC214 PNP	AE0031	3	-
Transistor J111N FET	AE0083	5	-
Transistor BC637 NPN	AE0068	2	2
Transistor BC638 PNP	AE0037	2	2
IC NE5532N Dual Op Amp	AE0221	5	-
IC TL072CP Dual Op Amp	AE0046	5	-
IC LM339N Quad Comparator	AE0071	2	-
IC CMOS 4051B	AE0118	1	-
IC CMOS 4053B	AE0117	1	-
IC CMOS 4099B	AE0238	1	-
IC CMOS 74HC259	AE2727	1	1
IC 6N136 Opto isolator	AE0222	1	-
IC TTL 74LS373N	AE0140	1	-
IC TTL 74LS138N	AE0248	1	-
IC Regulator 7805 (+5V DC)	AE0308	2	-

POWER SUPPLY:

Lamp Neon	AL0200	2	-
Mains Fuse 20mm T3.15A (UK, EC)	AL0464	5	-
Mains Fuse 20mm T5A (USA)	AL2270	5	5
Mains Fuse 20mm T8A (DC)	AL0487	5	5
Transformer 320VA	AM2720	-	-
Bridge Rectifier 25A 200V	AE0239	1	-
Transistor MJ3001	AE0240	2	-
Transistor cover (inc. split washers)	AK2767	2	2
Thyristor TIC126M	AE0272	1	-
IC Adjustable Regulator 783 (+48V DC)	AE0214	2	-
IC Regulator UA723CN (+/-16V DC)	AE0056	2	-
Fuseholder 20mm Panel Mount	AL0578	1	-
DC cable assembly (10pin plug to 10pin socket)	002-223	-	-
DC cable assembly (10pin plug to 5pin XLR)	002-225	-	-

RPSD2:

Mains Fuse 20mm T8.0A	AL0487	-	-
Mains Filter IEC 10A	AL2260	-	-
Mains Outlet IEC 3 Pin	AL2261	-	-
Mains Switch Rocker 0-1	AL0587	-	-
LED 5mm T1¼ Tri-colour	AE2258	-	-
Zener Diode BZX85 5V6	AE0012	-	-
RPSD2 / RPSD Packing assembly	002-058	-	-
RPSD DC Supply cable (8pin Cinch - 5pin XLR)	002-060	-	-
RPSD2 DC Supply cable (8pin Cinch-10pin fem)	002-227	-	-
IEC Mains Lead 3pin male to female	AH2262	-	-

METERPOD:

Preset 10K (calibrate)	AC0250	-	-
Meter VU+bulb	AD3321	2	-
Bulb (VU meter)	AD0013	5	-
Spacer PCB M3	AB0331	-	-
Screw M6 x 12mm SKT Hex Black (Grub)	AB2087	3	-
Screw M4 x 12mm CSK Hex Black	AB2086	10	-

Miscellaneous:

GL4000M-824 Packing assembly	002-474	-	-
GL4000M-832 Packing assembly	002-475	-	-
GL4000M-840 Packing assembly	002-476	-	-
GL4000M-848 Packing assembly	002-477	-	-
Facia 3 digit display	AA2726	-	-
Flex cable 12 way 90mm	AH2228	5	-
Flex socket 12 way 90deg	AL2226	-	-
Flex socket 12 way straight	AL2227	-	-
Ferrite Bead Axial	AF0610	-	-

SECTION B

B

FITTING INSTRUCTIONS

CAUTION !

TO AVOID DAMAGE TO INTERNAL COMPONENTS BY MISHANDLING AND/OR MISCONNECTION, ONLY TECHNICALLY COMPETENT PERSONNEL SHOULD ATTEMPT SERVICE WORK ON THIS CONSOLE.

GL4000 Expander Fitting instructions

ALLEN&HEATH

The GL4000 expander options are designed to attach to either side of the GL4000 console depending on console format. The expander can be fitted to consoles with the integral meterbridge as well as those consoles that do not have the integral meterbridge. The expander modules allow a GL4000 console to be expanded up to a maximum of 48 channels.

Please read the following instructions carefully before attempting to fit the module.

1. Check contents of pack to ensure all parts have been supplied.

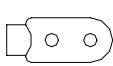

A
CATCHPLATE
QUANTITY 1
PART NO. AB0336

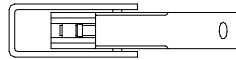

B
ADJUSTABLE FASTENER
QUANTITY 1
PART NO. AB0335



C
SCREW M6X8 SKT HEX
QUANTITY 2
PART NO. AB2421



D
SCREW M3X6 HEX
QUANTITY 3
PART NO. AB2813

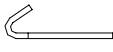

E
SCREW 6BX5/16
QUANTITY 40
PART NO. AB2810



F
SCREW M4X10
QUANTITY 4
PART NO. AB0271



G
NUT LOCK M4
QUANTITY 4
PART NO. AB0188



H
STUD M6X38.5
QUANTITY 5
PART NO. AB0325

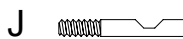

J
STUD SLOTTED
QUANTITY 2
PART NO. AB2406

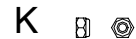

K
NUT LOCK M3
QUANTITY 3
PART NO. AB0102



P
SHAKEPROOF WASHER
QUANTITY 3
PART NO. AB0244

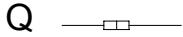

Q
OR LINK
QUANTITY 5
PART NO. AC0335

M
BASE BRACKET
QUANTITY 1
PART NO. AA2191

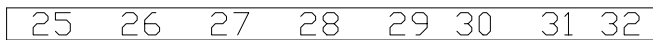

L
IDENT STRIP
QUANTITY 1 SET
PART NO.s AK2637 AK2638 AK2639 AK2703 AK2704
AK3112 AK3113 AK3114 AK3115 AK3116

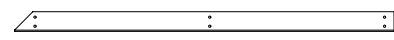

N
EARTH STRAP
QUANTITY 1
PART NO. 002-237

R
SIDE PLATES
QUANTITY 1 PAIR
PART NO: AA3849L&R

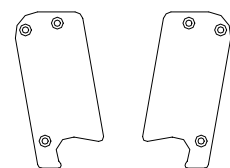
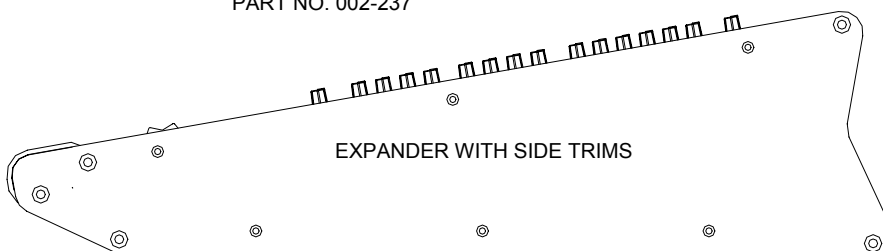

EXPANDER POSITIONING

2. The Expander unit must be fitted in the position shown in the diagrams below.

GL4000-824 + Expander

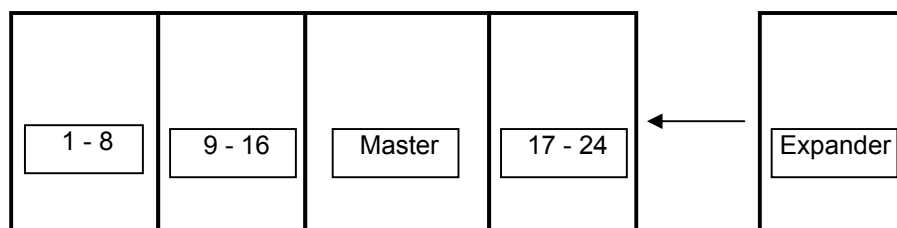

GL4000-832 + Expander

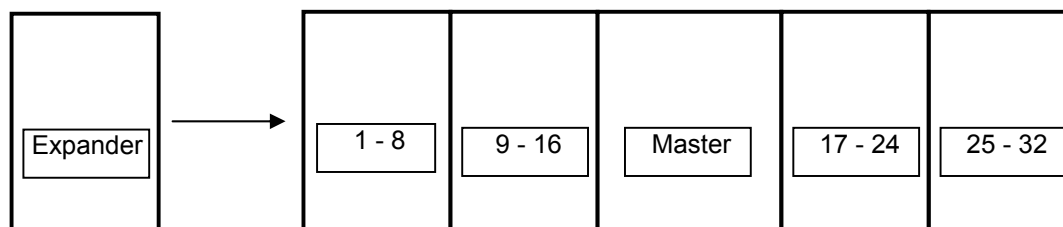

GL4000-840 + Expander

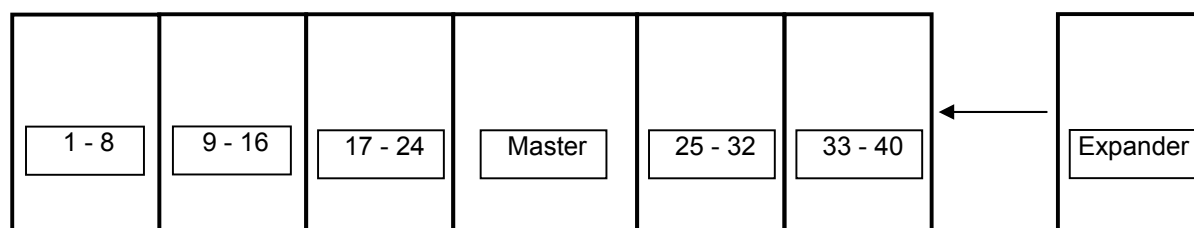

TOOLS REQUIRED:

The following tools are required to fit the expander module.

- 1x 2.5mm Hex key
- 1x 4mm Hex key
- 1x 1-point Pozi screwdriver
- 1x flat point screwdriver
- 1x long nose pliers
- 1x 5.5mm AF spanner
- 1x wire cutters
- 1x small tipped soldering iron and solder

INSTALLATION

Only technically competent personnel should attempt to fit the expander module. Disconnect the Power Supply Unit and cables from the console before fitting the expander module

3. Ensure you have a good work surface and clear area before starting work. Carefully invert the console and remove the base panel by removing all screws along the edges of the base panel. Also remove the 3 screws in the centre of the large base panel. Note; do not rest the console on the meterbridge.

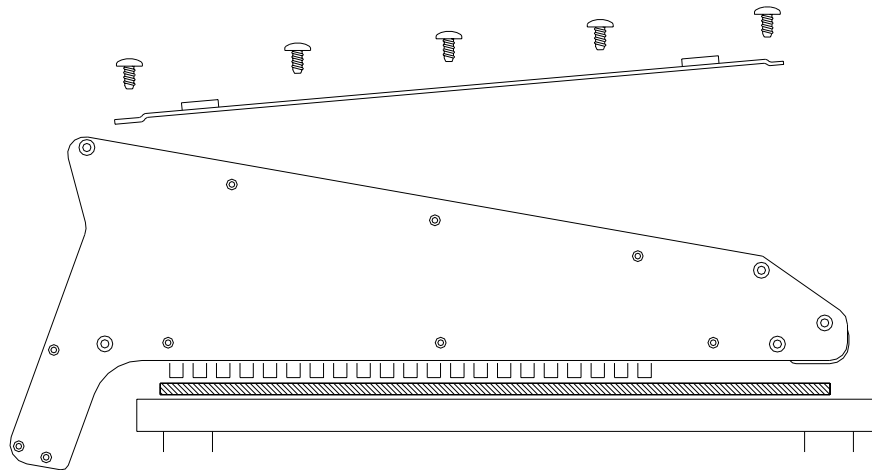

4. Remove the side trim and bracket from the side of the console that is to have the expander fitted. Similarly; remove the side trim and bracket from the side of the expander that is to be joined to the console.

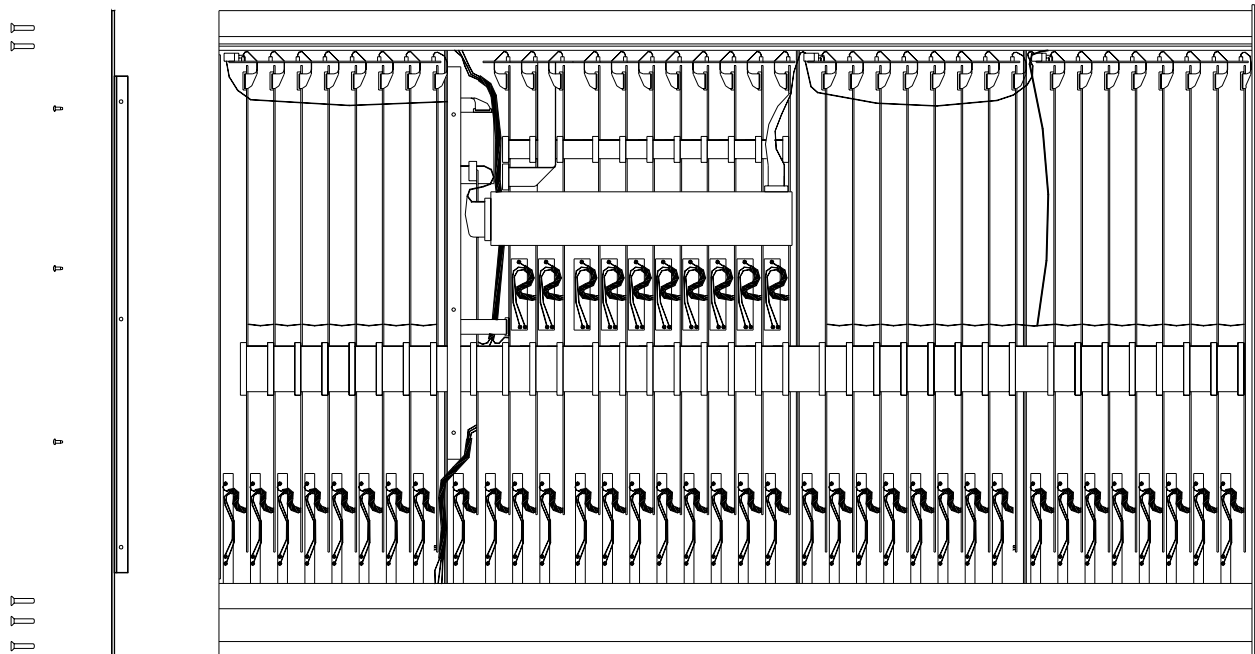
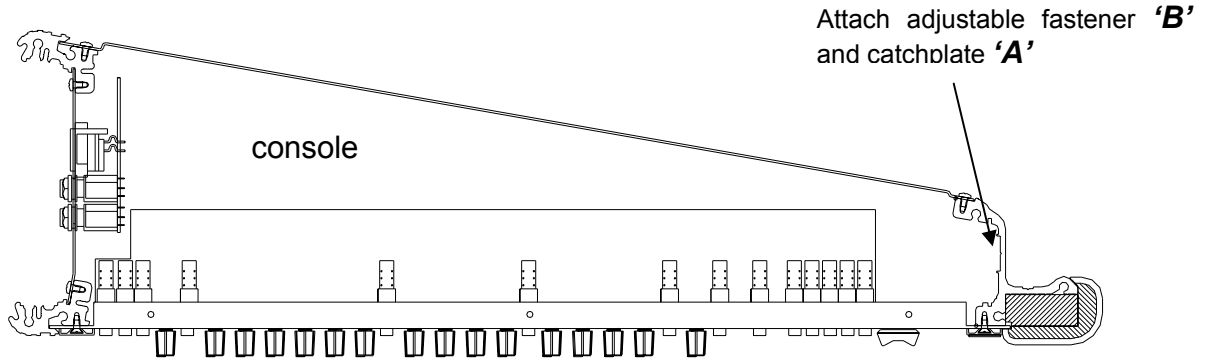
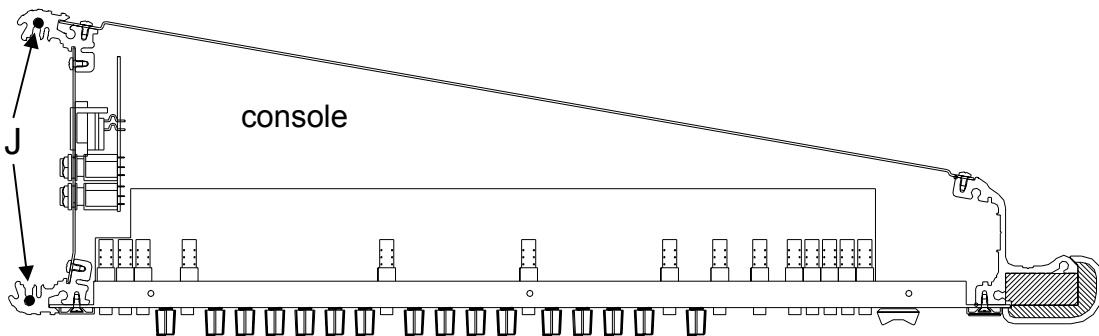

Figure shows console to be expanded on right hand side

- Attach the adjustable fastener **'B'** to the inside of the front extrusion of the console and catchplate **'A'** to the inside of the expander using screws **'F'** and nuts **'G'**. The mounting holes are located under the front armrest of each unit and are pre-drilled for the adjustable fastener and catchplate. Make sure the movement of the fastener lever does not interfere with the input channel circuit board assemblies.



- Screw the 2 slotted studs **'J'** into the upper and lower rear extrusions of the console. Rotate the studs until the flat is visible in the slots.



Console with integral meterbridge

- Screw the single slotted stud **'J'** into the lower rear extrusion of the console. Rotate the stud until the flat is visible in the slot.

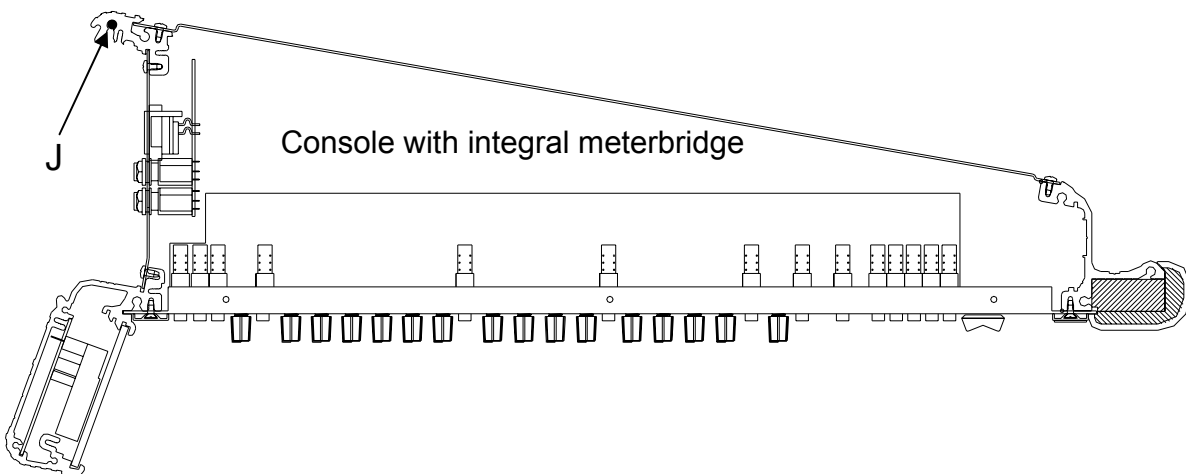

7. Screw the 5 plain studs **'H'** into the extrusion holes of the expander as shown below.

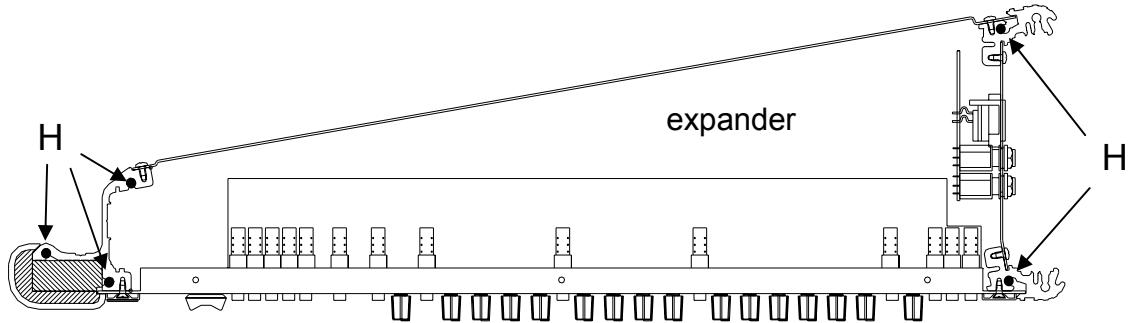

8. Slide the expander module onto the 7 studs and close the adjustable fastener **'B'** over the catchplate **'A'**, see 5. The fastener can be adjusted to ensure a good join. Screw in the locking screws **'C'** into the pre-tapped holes of the expander. Make sure the locking screws **'C'** engages with the flat of the slotted studs **'J'**, see diagram below.

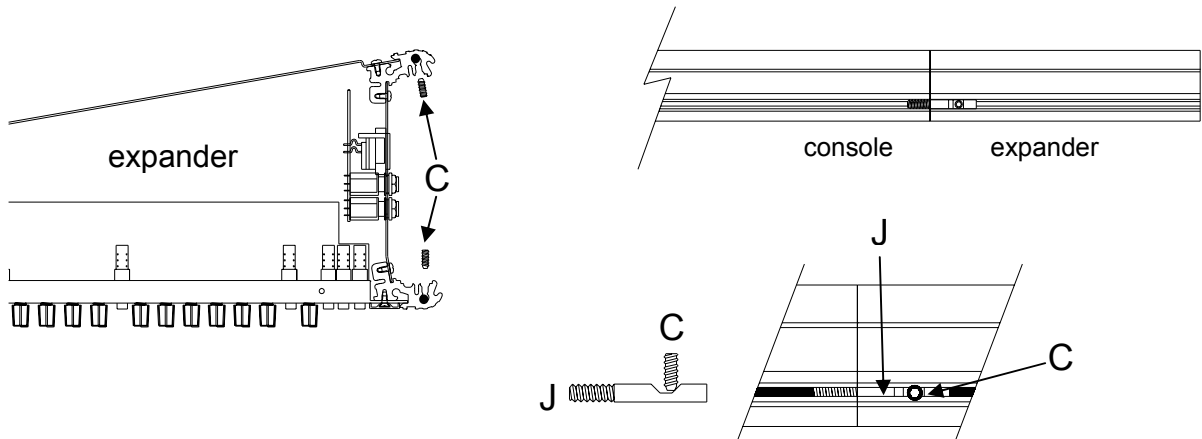

Console with integral meterbridge

8a. Slide the expander module onto the 6 studs and close the adjustable fastener **'B'** over the catchplate **'A'**, see 5. The fastener can be adjusted to ensure a good join. Screw in the locking screw **'C'** into the pre-tapped hole of the expander. Make sure the locking screw **'C'** engages with the flat of the slotted stud **'J'**, see diagram below.

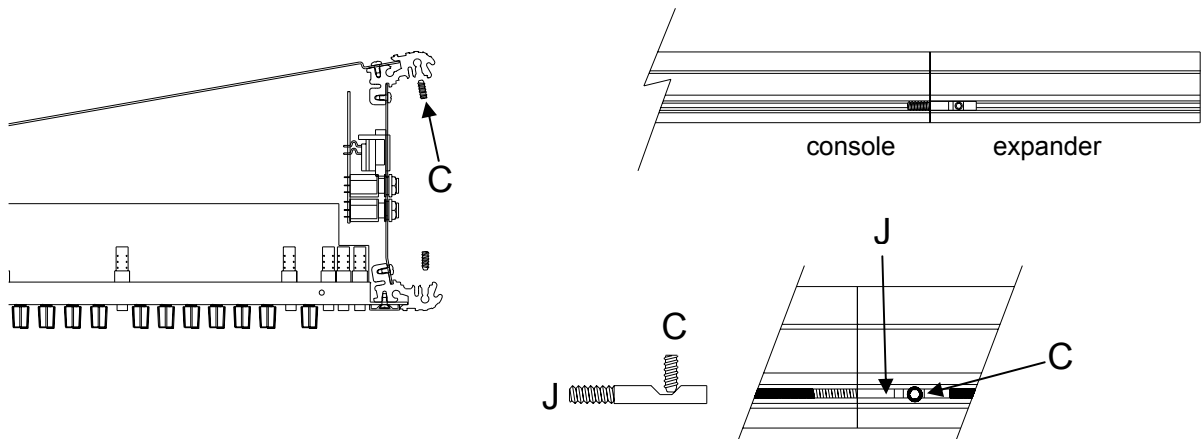

9. With the expander module and console securely clamped together, bolt the expander and console front panels together using bolts 'D' and lock nuts 'K' with a 5.5mm spanner. The input channel circuit board assembly nearest the panel flanges will have to be removed to gain access to the fixing holes.
10. Disconnect the main harness from the end input channel circuit board on the console. Connect the male connector on the expander harness to the console main harness. Re-connect the end Input circuit board with the extra connector on the expander harness.
11. The 16 way ribbon harness is factory fitted for attaching the expander onto the right hand side of the main console as shown. Connect the 16 way ribbon harness in same way as the main harness. If the expander is fitted on the left hand side then the 16 way ribbon harness will have to be repositioned accordingly.
12. Connect the expander green wire back to the console main extrusion using screw 'E' and washer 'P'. **Do not connect the wire back to the expander extrusion.**
13. Connect the short green wire strap 'N' across the join in the rear chassis extrusions of the console and expander module using screws 'E' and washers 'P'.

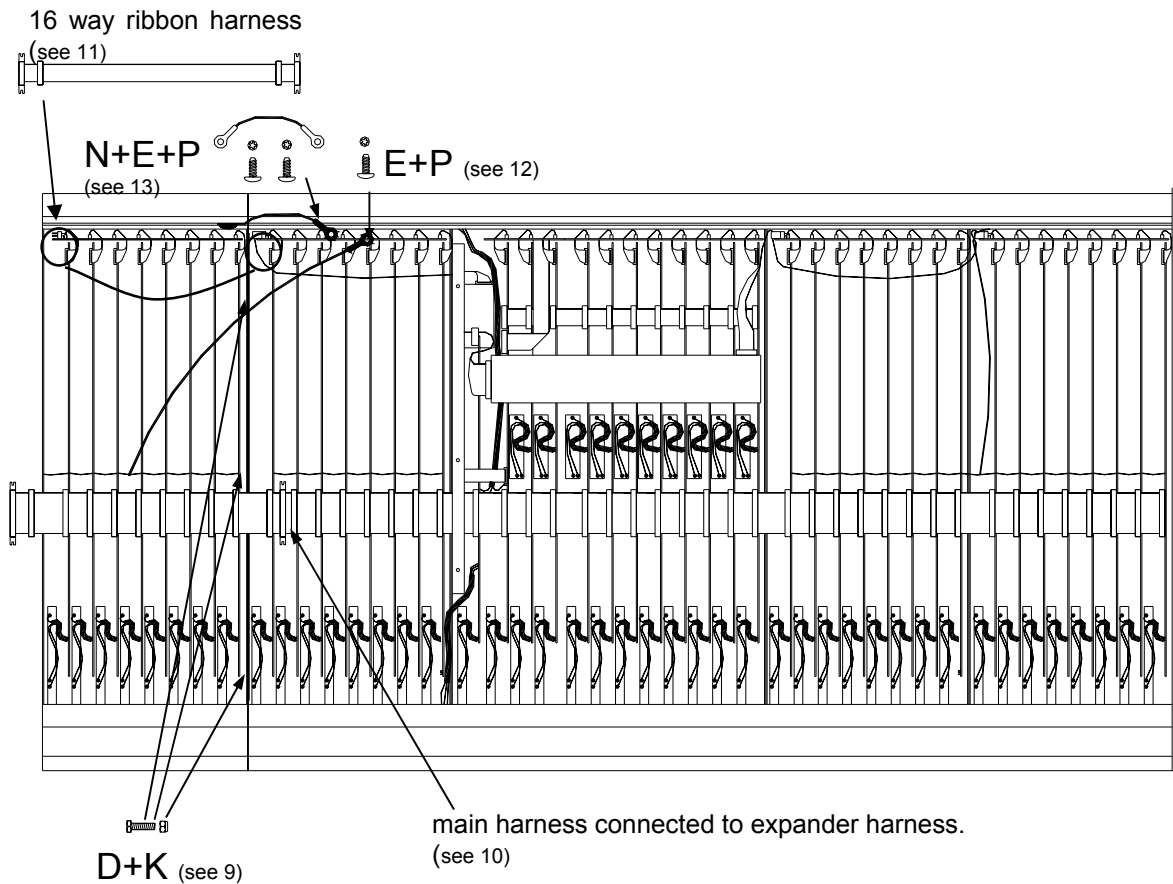

Console inverted and expanded on the right side.

EXPANDER ASSIGNMENT

14. Depending on whether the expander is positioned on the left or right hand side of the main console, one or more of the input connector circuit boards (AG2622) will have to be assigned to enable the channel mutes to function correctly.

For consoles that have the expander on the right hand side of the console (e.g. expanded GL4000-824S and GL4000-840S consoles) only the expander requires assignment.

For consoles that have the expander on the left hand side (e.g. expanded GL4000-832S consoles), all of the input connector circuit boards will have to have the existing assignment links removed and re-assigned. Refer to the assignment diagrams below.

The assignment links are 0R resistors 'Q', located next to the 16 way ribbon harness connector on the input connector circuit board. Fitting the links in various positions determines the assignment for each block of 8 input channel mutes.

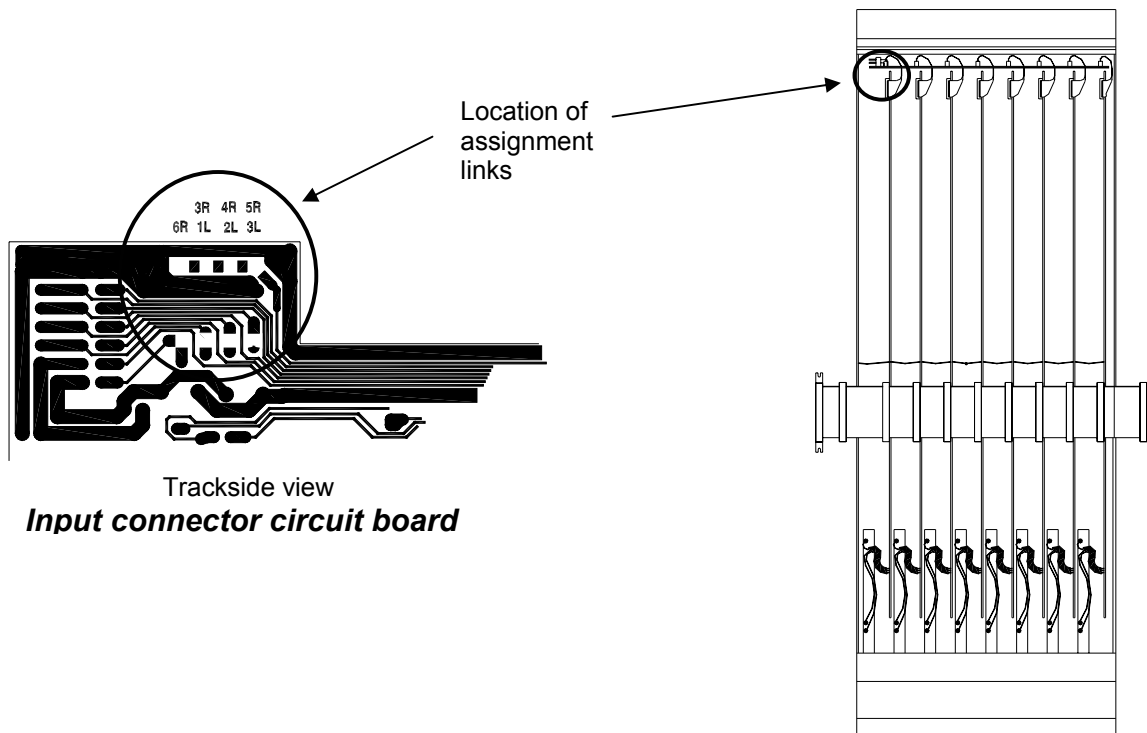

Link assignments for each input connector circuit board

To avoid having to remove the input connector circuit board, fit the links onto the track side of the circuit board

GL4000-824 + Expander

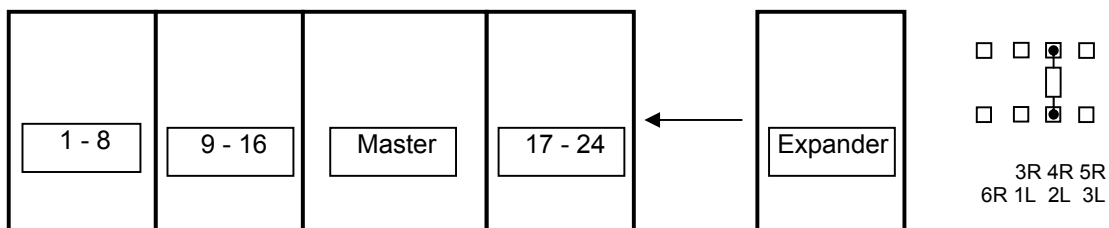

GL4000-832 + Expander

Note: remove existing assignment links on all connector circuit boards before re-assignment.

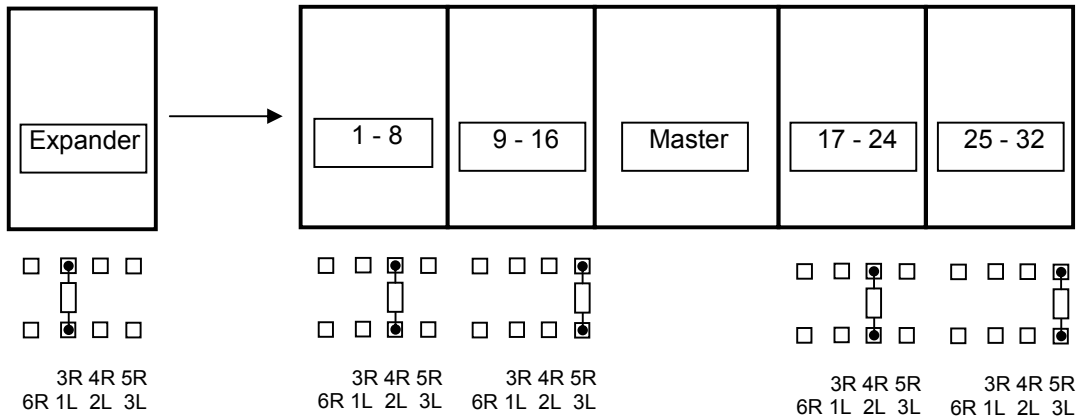

GL4000-840 + Expander

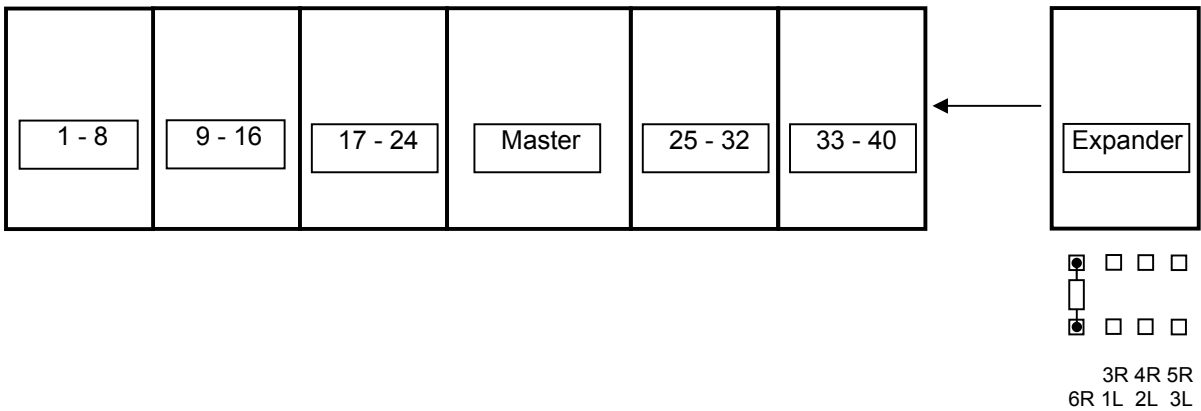

Attaching the base panels

15. Attach the base panel joining bracket '**M**' to the console base using screws '**E**'. Refit the base panels onto the expanded console using screws '**E**'.

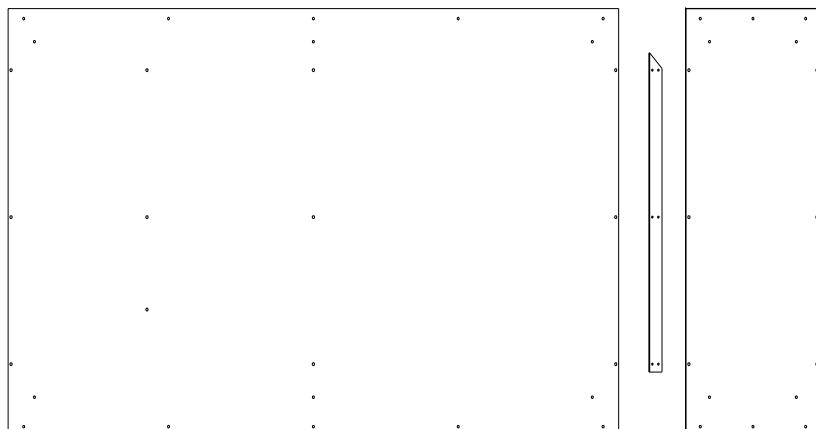

Console with integral meterbridge.

Fit the meterbridge side plate '**R**' using the screws from the original side trim.

NUMBER STRIP POSITIONING

16. Carefully turn the console the correct way up and fit the new number strips. A complete set of number strips 'L' is supplied with the Expander kit. The diagrams below show the combination of strips to be fitted to the expanded consoles.

GL4000-824 + Expander

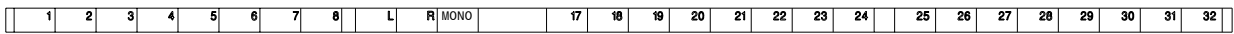
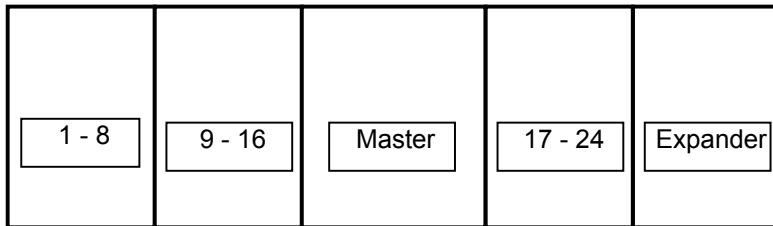

GL4000-832 + Expander

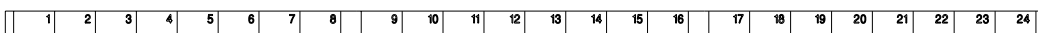
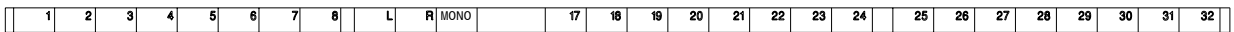
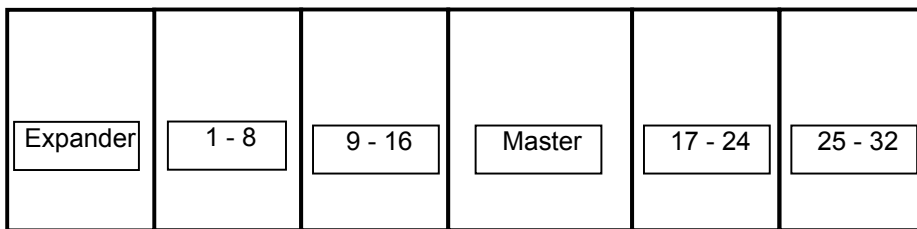

GL4000-840 + Expander

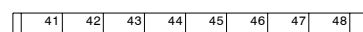
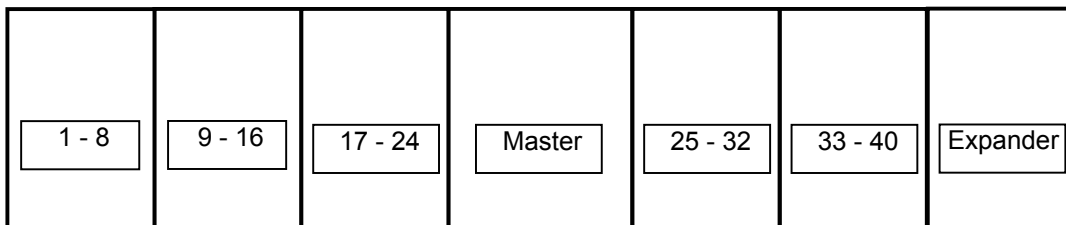

TESTING THE CONSOLE

17. The fitting of the expander module is now complete. Before re-plugging the console, apply power and check for correct operation e.g. mutes & PFL LEDs illuminate.

Please note; to prevent damage to the console chassis, the expanded console must be supported along its entire length.

Should you experience any difficulties in fitting this module or have any queries regarding your **GL4000** console please contact your **ALLEN & HEATH** agent. Include the console serial number in any correspondence.

ALLEN&HEATH

GL4000

MIXING CONSOLE

SYS-LINK

EXPANDER OPTION

This option connects a GL4000 console as a channel expander to a second console with just one or two interconnecting cables.

Kit GL4000-SL1 = SINGLE

Single option to install SYS-LINK to one GL4000 console to allow interconnection to a second console already fitted with SYS-LINK.

Kit GL4000-SL2 = DUAL (2x GL4000-SL1)

Dual option to install SYS-LINK to two GL4000 consoles.

Interconnecting cables not supplied.

For information on using SYS-LINK please refer to APPLICATIONS NOTE AP2787

FITTING INSTRUCTIONS

Publication AP2786

Issue 2 July 01

FITTING THE GL4000 SYS-LINK EXPANDER OPTION

1 CHECK THE CONTENTS :

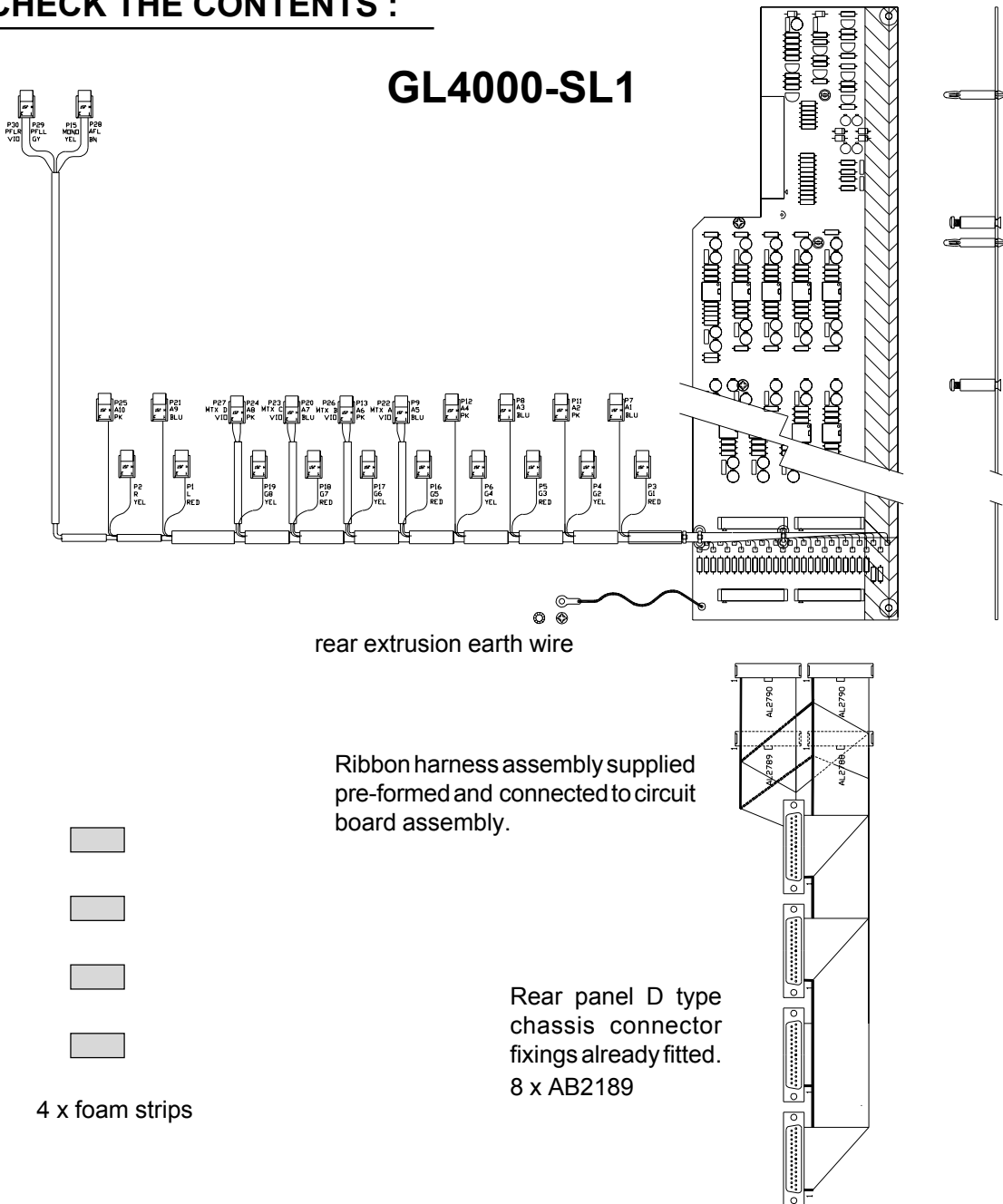
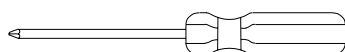

fig. 1

Contents:

- 1x SYS-LINK circuit board assembly with interconnecting harness and mountings already fitted.
- 1x SYS-LINK ribbon harness assembly with D type chassis connector fixings already fitted.
- 1x SYS-LINK Fitting Instructions (AP2786)
- 1x SYS-LINK Application notes (AP2787)
- 4x self adhesive foam pads (AK0332)

2 TOOLS REQUIRED :



1pt & 2pt CROSS POINT

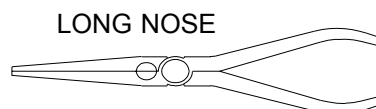

LONG NOSE

Only technically competent personnel should attempt to fit the SYS-LINK option. Disconnect the Power Supply Unit and cables from the console before fitting the expander module.

③ PRELIMINARY:

To fit the SYS-LINK option it is necessary to partially remove the INPUT CHANNEL circuit board assembly next to the GROUP 1 circuit board to enable access to the SYS-LINK circuit board mounting holes. The INPUT CONNECTOR circuit board assembly behind the SYS-LINK D type connector mounting holes on the rear panel will also have to be removed. It is not necessary to remove any other circuit board assemblies as access to the SYS-LINK connections can be made with a pair of long nose pliers.

④ REMOVE THE KNOB CAPS:

Pull off the knob caps and unscrew the nuts from the INPUT CHANNEL next to GROUP 1 channel. The switch caps can remain in place.

Remove the optional Meterbridge if fitted.

⑤ REMOVE THE CONSOLE BASE :

Carefully invert the console and remove the base panel by removing all screws along the edges of the base panel. Also remove the 3 screws in the centre of the largest panel

⑥ REMOVE THE INPUT CONNECTOR CIRCUIT BOARD ASSEMBLY:

The INPUT CONNECTOR circuit board assembly (A) directly behind the SYS-LINK connector mountings on the rear panel must be removed to gain access to the SYS-LINK D type connector mounting holes.

Follow the procedure below:

- 1 Unscrew the 16 XLR mounting screws and remove the 32 jack socket nuts on the rear connector panel.
- 2 Disconnect the 8 flexible flat cables (C) from the INPUT CHANNEL circuit board assemblies.
- 3 Disconnect the ribbon harness (D)
- 4 Carefully remove the INPUT CONNECTOR circuit board assembly (A) and place to one side.
- 5 Now remove the SYS-LINK blanking plate.

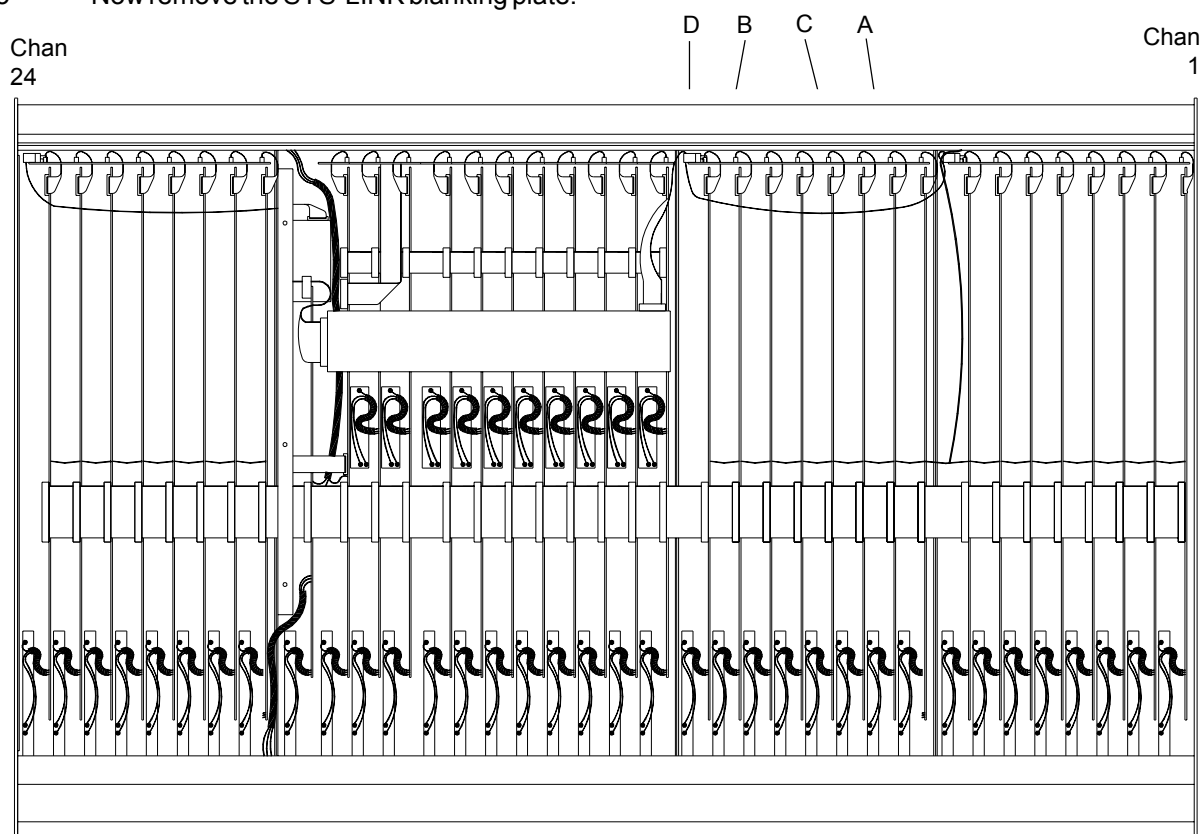

GL4000-824 inverted with the base cover removed.

fig. 2

- 7 Referring to fig. 2, disconnect the MAIN HARNESS (E) plugged into the connectors mounted along the edge of the circuit boards from INPUT CHANNEL 1 to GROUP 2.
- 8 The Input channel circuit board assembly next to GROUP 1 circuit board can now be removed and placed on the adjacent Input channels. Take care not to stretch the fader wires that are still connected.
- 9 Remove the 8 screw fixings already partly screwed into the D type connectors on the SYS-LINK ribbon harness assembly and place to one side.
- 10 Referring to fig. 3, fit the 4 self adhesive foam pads (F) in the positions indicated next to the front panel flange.

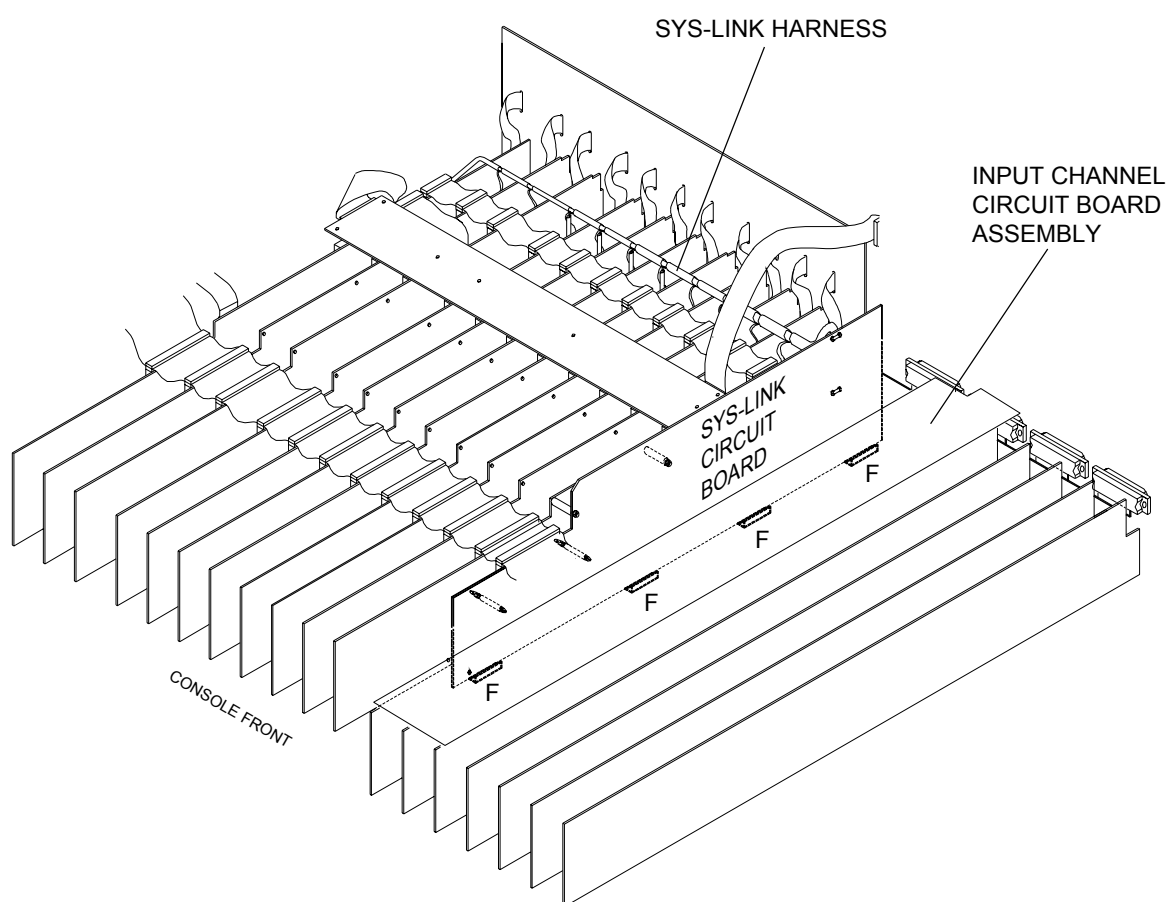

GL4000-824 inverted with the input connector circuit board assembly removed.

fig. 3

11 FITTING THE SYS-LINK RIBBON HARNESSES :

Place the SYS-LINK circuit board assembly next to the GROUP 1 circuit board with the harness and ribbon cables to the rear of the console. see fig. 3.

Slide the pre-formed SYS-LINK ribbon harnesses toward the back of the console and down the gap between the Channel Input circuit boards and the back panel. Check the connectors are mounted into the correct apertures on the rear panel.

Mount the 4 D type connectors using the 8 hex screws provided. see 9

12 FITTING THE SYS-LINK HARNESS ASSEMBLY :

Referring to fig. 4, use a pair of long nosed pliers to fit the connectors onto GROUPS 1 - 8 and the LEFT RIGHT and MONO circuit board assemblies in the following order:

GROUP 1 to GROUP 8, then LEFT, RIGHT and then finally the MONO circuit board assembly.

SYS-LINK ribbon harnesses removed for clarity.

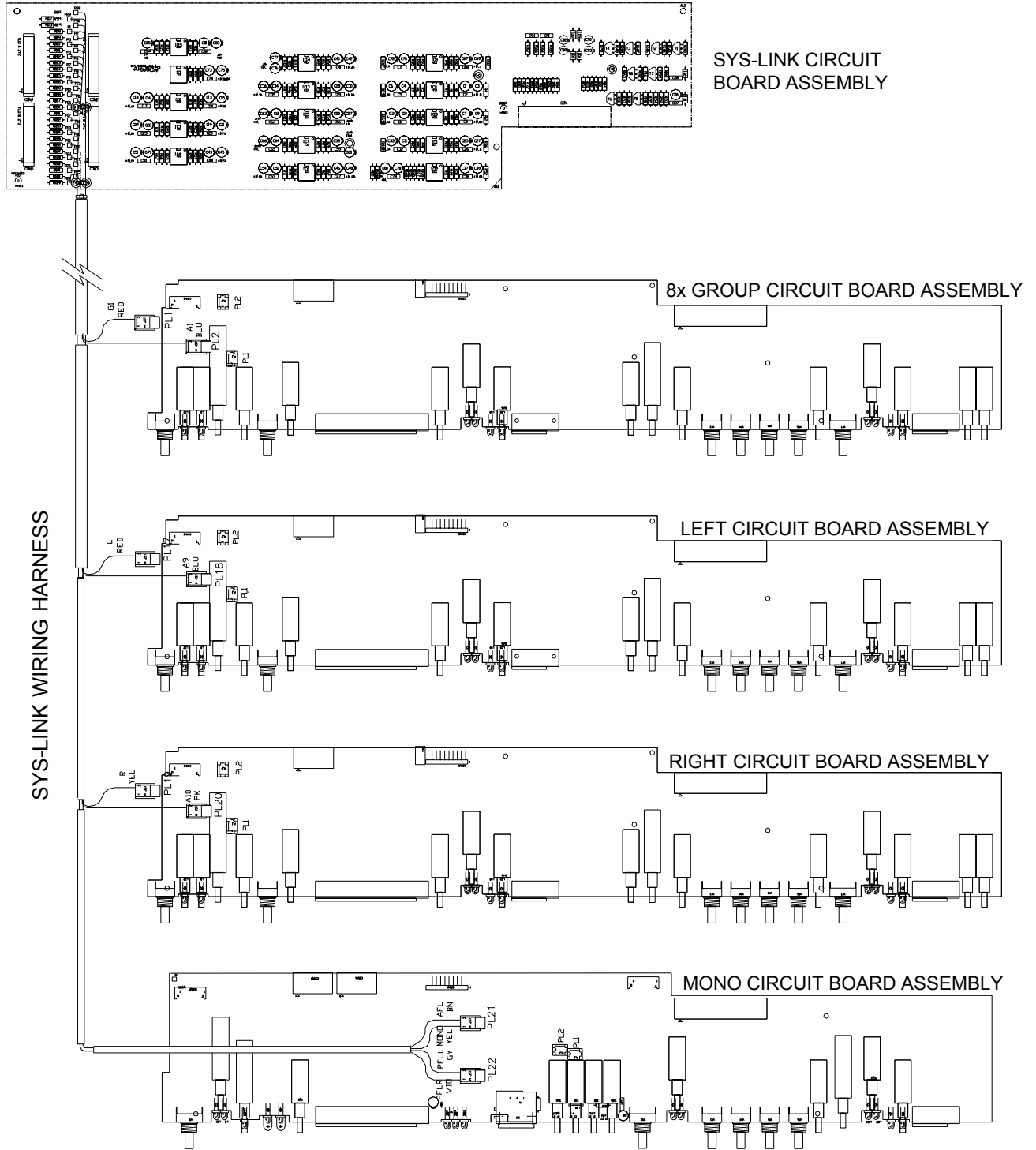

SYS-LINK harness circuit board interconnections

fig. 4

13 MOUNTING THE SYS-LINK CIRCUIT BOARD:

The SYS-LINK circuit board mounts onto the GROUP 1 circuit board using the 4 pillars already fitted to the circuit board assembly. Two of the mounting pillars are fixed with screws (G) and two are 'snap-fit' (H).

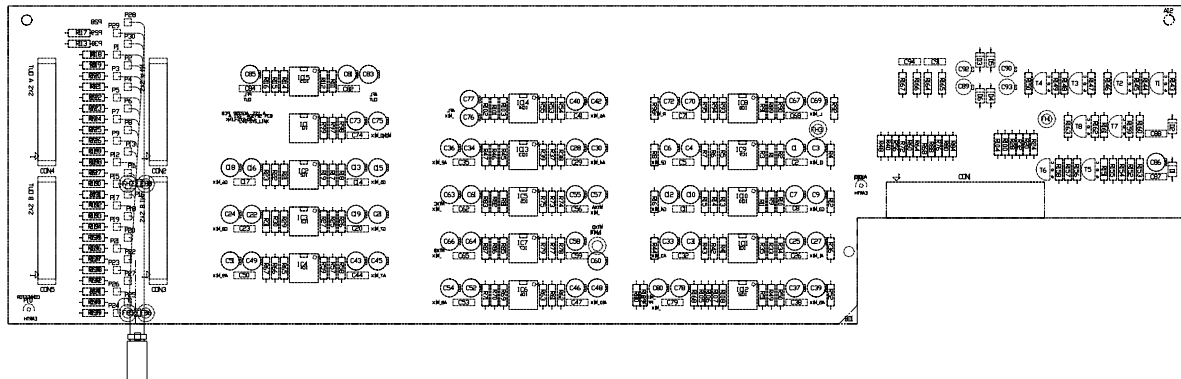

fig. 5

To fit the SYS-LINK circuit board to the GROUP circuit board, unscrew the 2 screws already partly screwed into the mounting pillars (G) and align all 4 pillars with the holes in the GROUP circuit board. Press the two pillars (H) onto the GROUP circuit board assembly and fix the two pillars (G) with the screws provided.

- 14 Refit the INPUT CHANNEL circuit board assembly. Do not fit the channel nuts or knobs at this stage. see 18

15 REFITTING THE INPUT CONNECTOR CIRCUIT BOARD ASSEMBLY

To refit the INPUT CONNECTOR circuit board into the console. Follow the procedure below referring to fig. 2:

- 1 Locate the circuit board assembly into the rear panel of the console.
- 2 Replace the 16 XLR mounting screws and the 32 jack socket nuts.
- 3 Reconnect the 8 flexible flat cables (C) into the sockets on the input channel circuit board assemblies
- 4 Plug on the ribbon harness (D).

- 16 Screw the SYS-LINK green earth wire onto the rear extrusion of the console with the screw and shakeproof washer provided

- 17 Referring to fig. 2, re-fit the MAIN HARNESS (E) onto all circuit boards. Check the harnesses are correctly aligned onto the circuit board connectors with pin 1 aligned with the red stripe of the ribbon harness.

18 REFITTING THE BASE :

Refit the base. Turn the console the correct way up and fit the pot nuts and knobs to the INPUT CHANNEL replaced in 14

19 PLUG ON THE INTERCONNECTING CABLES:

SYS-LINK connectors are female 25way D-type. Use 25way D-type male to male connector cables. Connect pin one to pin one on all connectors. Connect shield (screen) to 0V. Standard cables are available from electronic suppliers or computer shops. It is advised that the cable is a screened type less than 10 metres. Use professional quality locking connectors.

When connecting to equipment other than the GL Series link all unused audio inputs to 0V earth at the SYS-LINK input.

20 TEST THE SYSTEM:

Test all SYS-LINK inputs and outputs for correct signal level and quality by probing the D-connector pins or by interconnecting two consoles with SYS-LINK fitted. Test the PFL & AFL system for correct DC buss switching.

The SYS-LINK circuit diagram and technical details are included for reference.

The SYS-LINK Applications Note AP2787 is included separately with these fitting instructions. Provide this note to the user as applicable.

Please refer any queries to your Allen & Heath appointed service agent.

ALLEN & HEATH

GL4000

MIXING CONSOLE

THE BENEFITS OF USING SYS-LINK

The **GL4000** SYS-LINK option allows console to console interconnection by means of just one or two cables. By connecting two **GL4000** consoles together the number of input channels may be increased. One console acts as a channel expander (slave) to the second (master). Up to 3 consoles may be 'daisy-chained' in this way. The system is also directly compatible with other A&H consoles fitted with SYS-LINK.

Plugging consoles together using SYS-LINK connects the signals directly to the console busses so avoiding the use of the main console outputs and channel inputs for the master / slave connection. All the console channels are available to the user for input sources.

SYS-LINK CONNECTIONS

SYS-LINK connects all the console main busses including L, R, Mono, 8 Groups, 10 Aux sends, and 4 matrices. The PFL & AFL systems are also interconnected such that operating PFL or AFL on the slave console activates the master console monitor system. Operating PFL or AFL on the master does not activate the slave monitor system which may be used for 'local' monitoring if required. SYS-LINK connects the PFL & AFL audio mix and DC control buss. SYS-LINK outputs are taken **pre-fader** so that the slave console output connectors may be used for sub-mix or 'zone' feeds if required. All output signals are unbalanced, low impedance and operate at a line level of -2dBu to prevent problems with audio interference and to maintain a headroom of 23dB.

SYS-LINK inputs are unbalanced, operate line level at -2dBu and are high impedance to prevent loading the connected source.

SYS-LINK is presented on two pairs of 25way female D-type connectors, one for the console buss inputs and the other for the outputs. Several pins are provided for audio 0V earth.

USING SYS-LINK

Connect consoles using two standard 25way male to male D-type cables, available from electronic suppliers or computer shops (25line male to male). It is advised that this cable is a screened type if longer than 1 metre, no longer than 10 metres in total, and that professional quality locking connectors are used. Connect all pins one to one with the screen to 0V.

Connect the slave console SYS-LINK output to the master console SYS-LINK input.

SYS-LINK may also be used to connect the **GL4000** to other audio equipment. Make sure that all unused inputs (except the PFL & AFL DC inputs) are linked to 0V earth at the SYS-LINK input to prevent audible interference from connected audio signals. Connect line level signals of around -2dBu. The **GL4000** PFL & AFL systems may be activated by switching the PFL or AFL DC inputs to 0V earth through a 15k ohm resistor.

For information on fitting SYS-LINK please refer to FITTING INSTRUCTIONS AP2786

SYS-LINK APPLICATIONS NOTE

Publication **AP2787**

Issue 2 July 01

CONSOLE TO CONSOLE CONNECTION USING SYS-LINK

SYS-LINK connectors are 25way D-type female.
 Use 25way D-type male to male connector cable.
 Use screened cable, connect all pins.

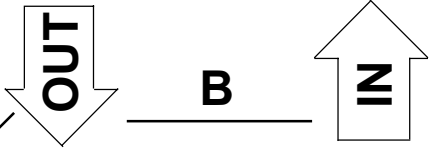
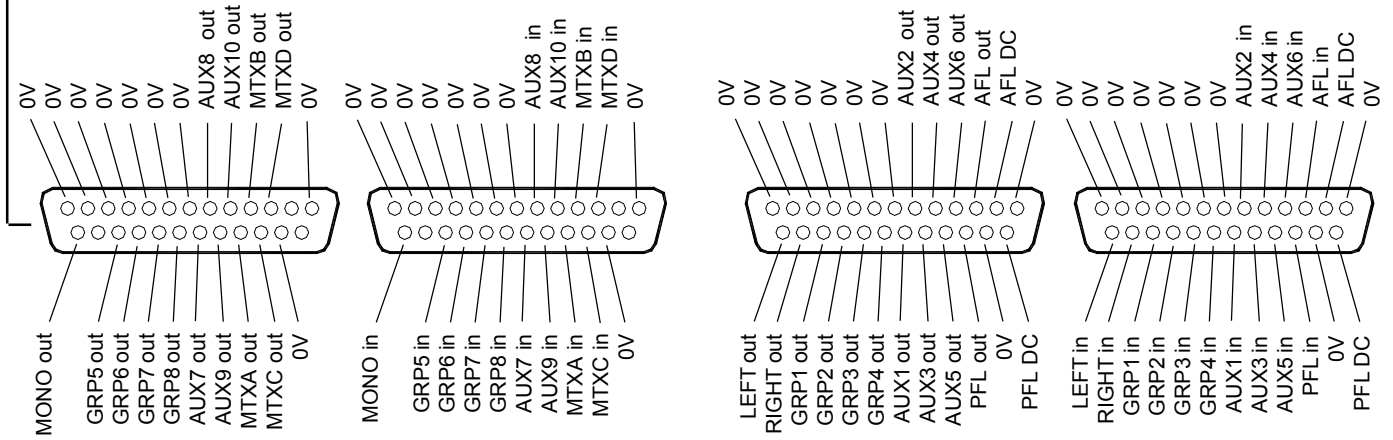

Line level output at -2dBu
 Unbalanced, in-phase
 Low impedance <75 ohm
 P/AFL DC output is open collector sink to 0V through 15k.
 All outputs are **pre-fader**

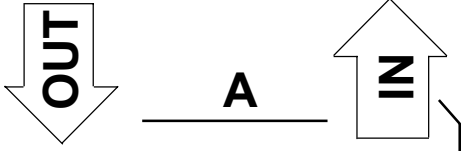

Line level input at -2dBu
 Unbalanced, buffered in-phase
 High impedance > 10k ohm
 P/AFL DC input for pulldown to 0V through 15k resistor.
When connecting to equipment other than GL Series link all unused audio inputs to 0V earth at the SYS-LINK connector.

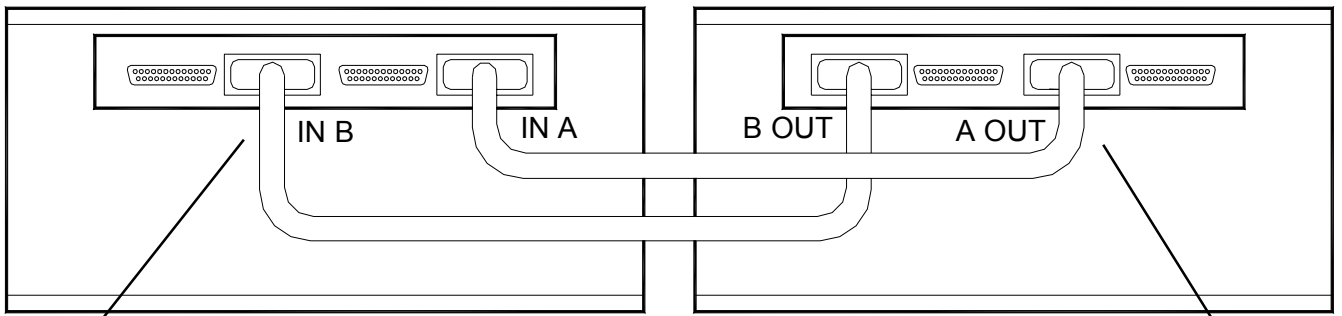

B to link GRP 5-8, AUX 7-10, MTX A-D

A to link GRP 1-4, AUX 1-6, L, R, PFL & AFL

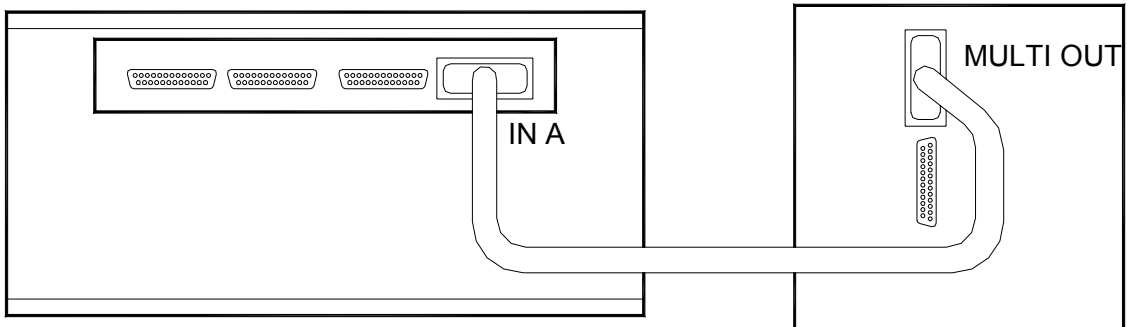

MASTER GL4000 ← **SLAVE GL2**

METERBRIDGE FITTING INSTRUCTIONS

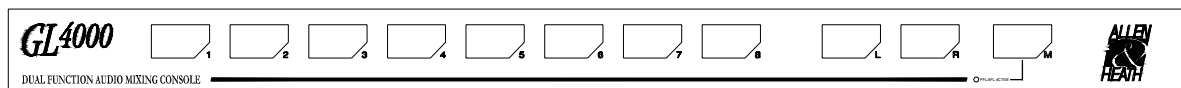

GL4000 meterbridge shown

The meterbridge has been designed to compliment the Allen & Heath **GL** series of Live consoles. Its purpose is to monitor the programme signal at the console main outputs i.e; Groups 1 to 8, Left, Right and Mono. The meterbridge is available in various sizes to fit each console size and runs full length.

Connecting the meterbridge to a console is very easy and only requires plugging in the meterbridge harness and tightening the three "grub" screws in the lower lip of the meterbridge.

To fit the meterbridge:

- 1.) Carefully unpack the meterbridge and fit it over the console rear extrusion (A) as shown in fig 1. Make sure all of the grub screws (B) are fully withdrawn from the meterpod extrusion (C) before fitting.
- 2.) Once the meterbridge is in place, tighten the grub screws (B) to secure the meterbridge in place.
- 3.) Plug in the meterbridge harness (D) into the connector marked **METERPOD** on the rear panel of the console. See fig. 2.

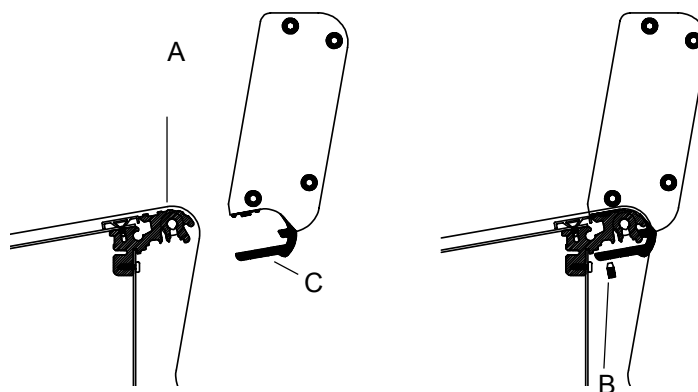

FIG. 1

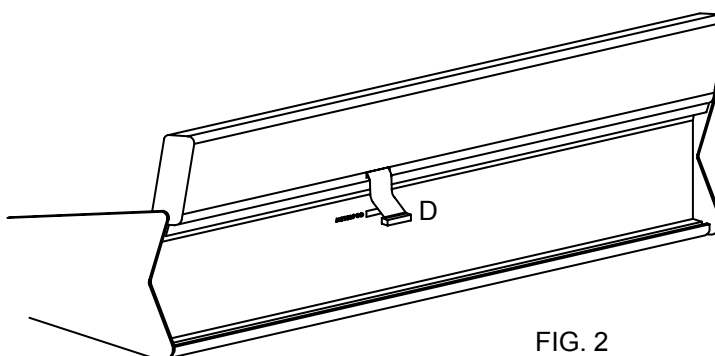

FIG. 2

Please note; the PFL LED indicator illuminates when any PFL is selected with the PFL signal level displayed on the MONO meter.

Manufactured in the UK by:
 Allen & Heath Limited
 Kernick Industrial Estate,
 Penryn,
 Cornwall. TR10 9LU.
 tel: 44 (0) 870 755 6250
 fax: 44 (0) 870 755 6251
<http://www.allen-heath.com>

Publication AP2126 Issue 4
 copyright©2001 ALLEN& HEATH. All
 rights reserved.

SECTION C

C

TECHNICAL DIAGRAMS

CAUTION !

TO AVOID DAMAGE TO INTERNAL COMPONENTS BY MISHANDLING AND/OR MISCONNECTION, ONLY TECHNICALLY COMPETENT PERSONNEL SHOULD ATTEMPT SERVICE WORK ON THIS CONSOLE.

Attention Service Departments

TECHNICAL BULLETIN

Ref.: AHTB96010	Issue No 1	Date 16/01/97	Page 1 of: 1
Title: New fader specified for GL4000			Authorisation: CD

The following information applies to all GL4000 consoles after serial number 401300.

Origin of the change:

In accordance with Allen & Heath's policy of continual product development, a new fader has been specified for GL4000 consoles. The fader offers a custom taper that has been designed to match the needs of engineers using the consoles in today's live environment.

Details:

GL4000's with serial numbers which precede the cut-off number stated above have been fitted with Jung Poon faders. The order codes for these are:

AI2665 - Mono Fader

AI2664 - Stereo Fader

GL4000's from Serial No 401300 onwards will be fitted with the Alps K-fader which has a special taper. The numbers for these are as follows:

AI8109 - Mono Fader

AI8110 - Stereo Fader

Note that since the tapers of the two faders are different, it will be necessary to check that the correct fader is ordered whenever replacements are needed. Otherwise, the channel gain will not correspond to the fader panel silk-screen.

Please note however that the audio performance of the console will not be compromised by inadvertently fitting the 'wrong' fader type. The channel will perform equally well with either fader type.

FRONT PANEL LAYOUT

FRONT PANEL LAYOUT

OPERATING MODES FRONT-BY-HOUSE

STAGE MONITOR

RECORDING LIVE

2TRK

ALLEN & HEATH GL4000

PATCH DISPLAY

QUICK SOLID STATE EDIT

EDIT SAFES

PREVIEW

RECALL

PATCH

ALL CHANNEL MUTE

808 PFL TRIM

L-R MIX

STEREO MONO

LOCAL LEV

PHONES

1 2 3 4 5 6 7 8 9 10

GROUP

24 1 2 3 4 5 6 7 8 L R MONO 25

The image shows a detailed front panel layout for the Allen & Heath GL4000 console. It features 24 channels, each with a mixer section, a monitor section, and a pan section. The mixer section includes a mute button, a safe/preview button, a level knob, and a pan knob. The monitor section includes a meter, a main level knob, and a solo button. The pan section includes a pan knob and a solo button. The console also features a central control section with 10 meters, a patch display, and various control buttons. The right side of the console includes a stereo section with a 2TRK button, a return knob, and a stereo/mono button. The bottom of the console is labeled with channel numbers 24, 1, 2, 3, 4, 5, 6, 7, 8, L, R, MONO, and 25.

REAR PANEL LAYOUT

INPUT SECTION

MONO

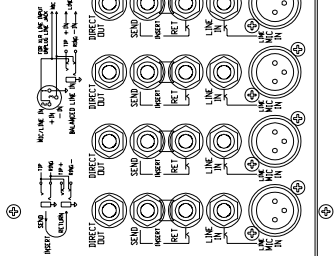

MASTER SECTION

STEREO

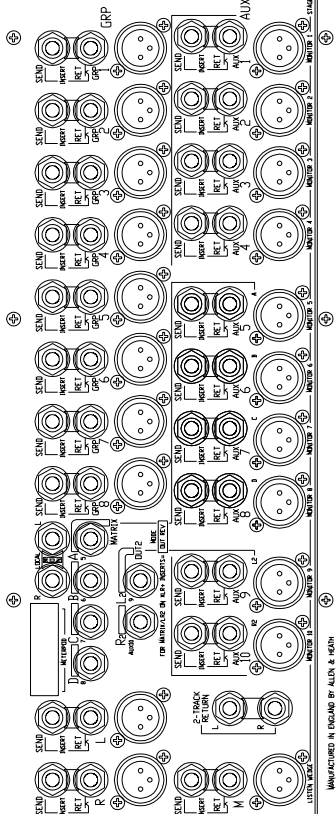

INPUT SECTION

STEREO

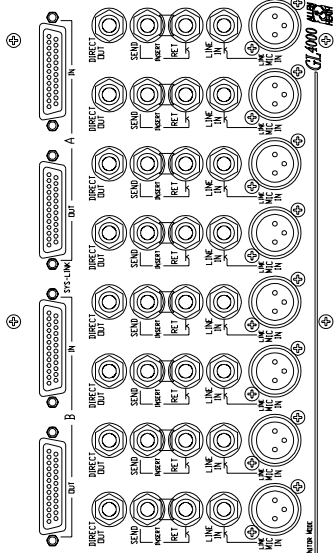

MANUFACTURED IN ENGLAND BY ALIX & HEATH

SERIAL NO.

CT 4009 P25 1967

MONO / STEREO INPUT & TALKBACK

SHEET 1 OF 3

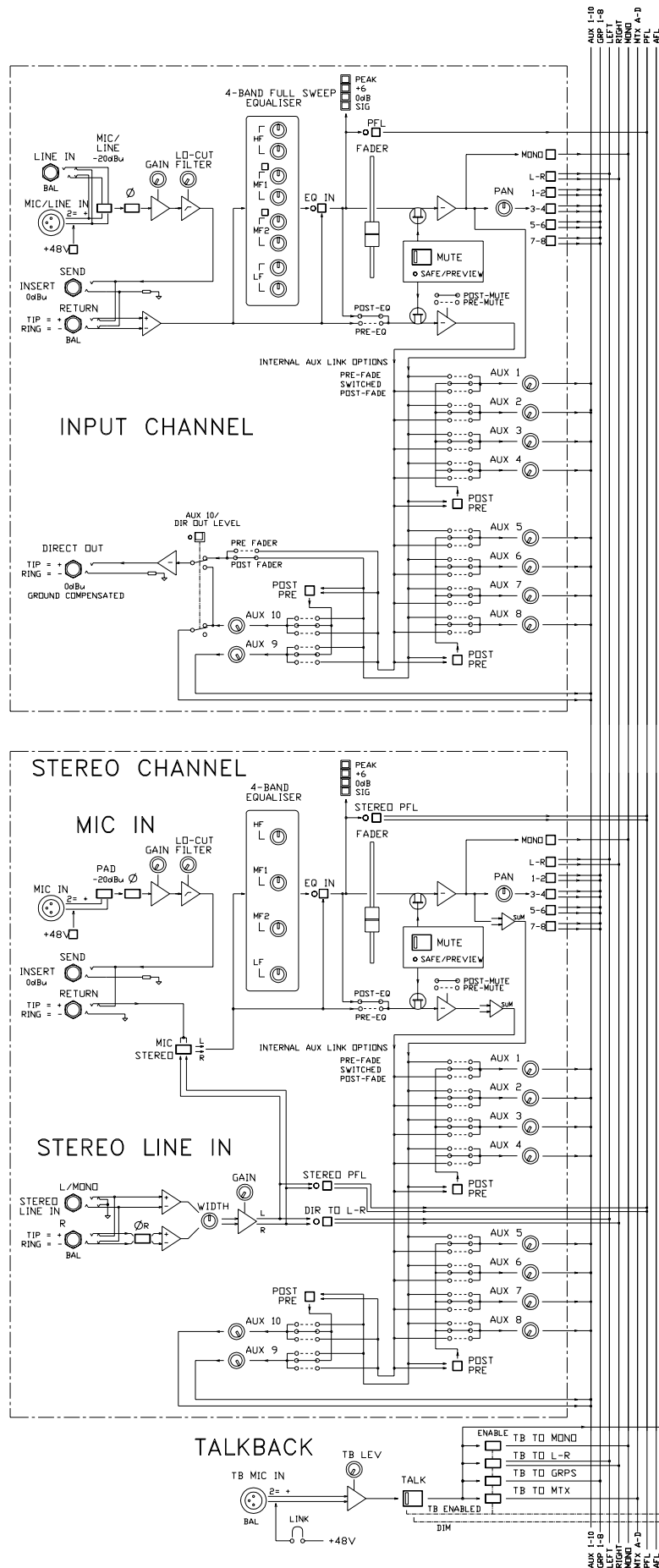

GROUP / AUX / MATRIX / LR / MONO / 2 TRACK

SHEET 2 OF 3

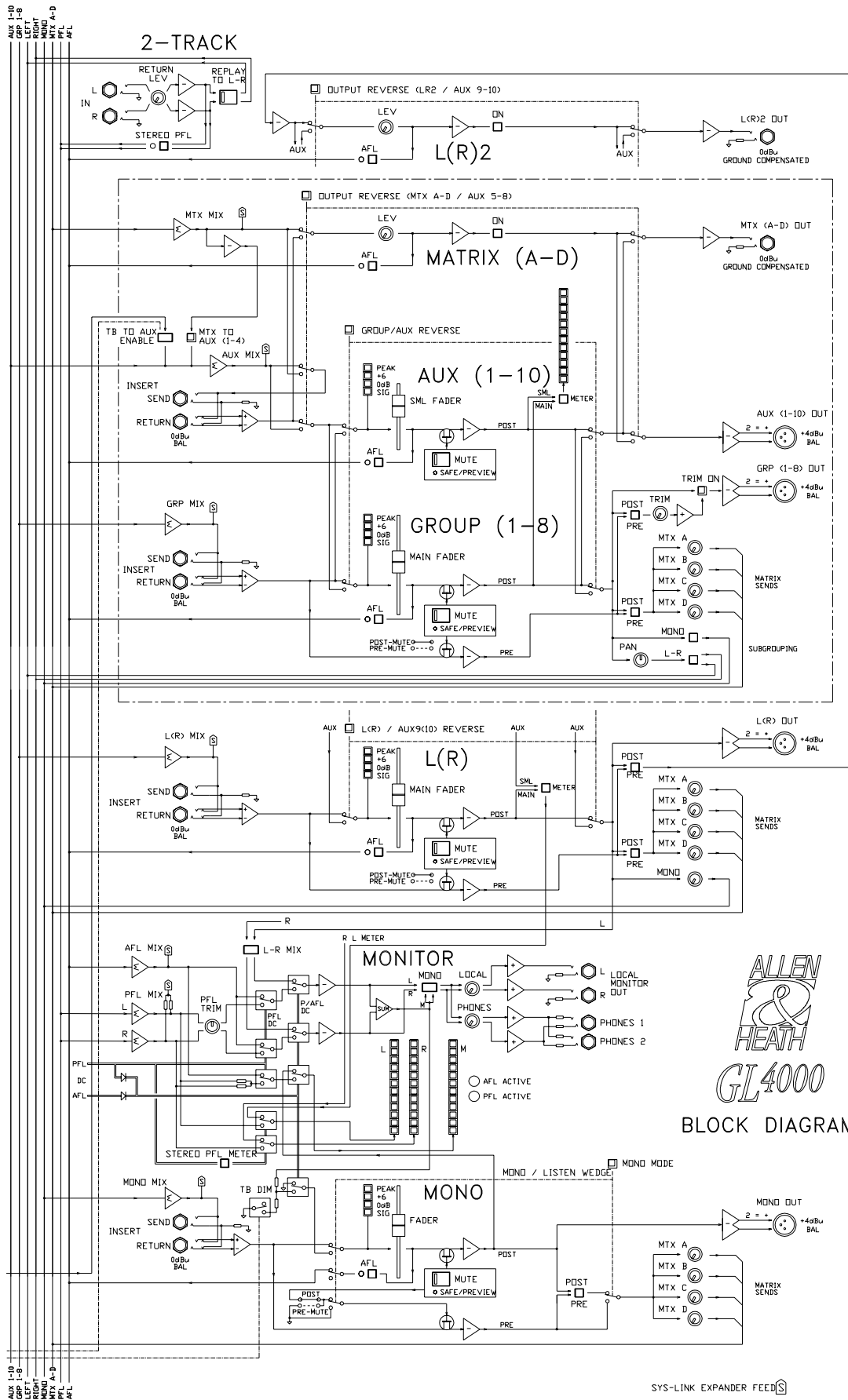

MUTE AUTOMATION

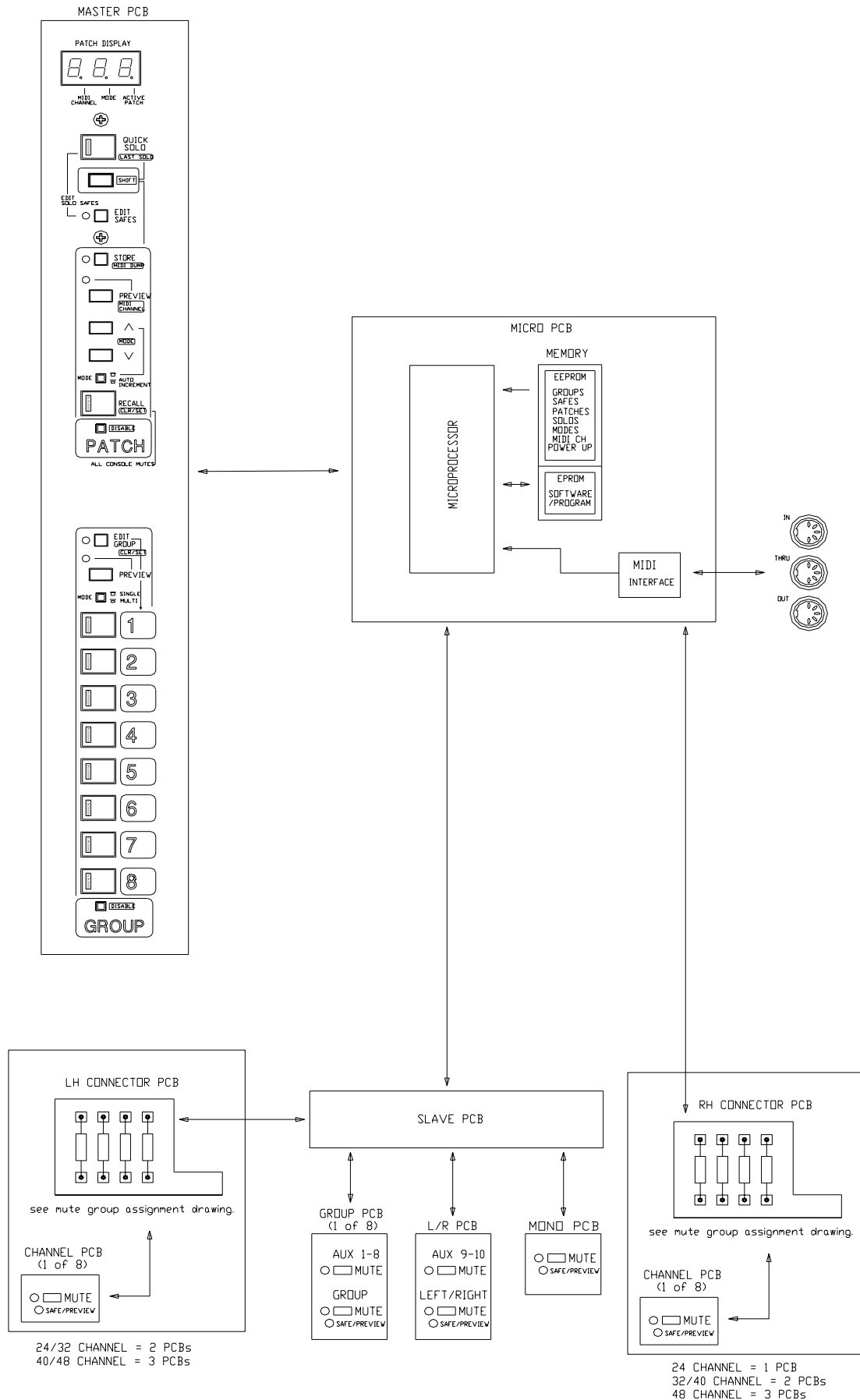

GL4000-824 INTERNAL LAYOUT

Console inverted with the base removed.

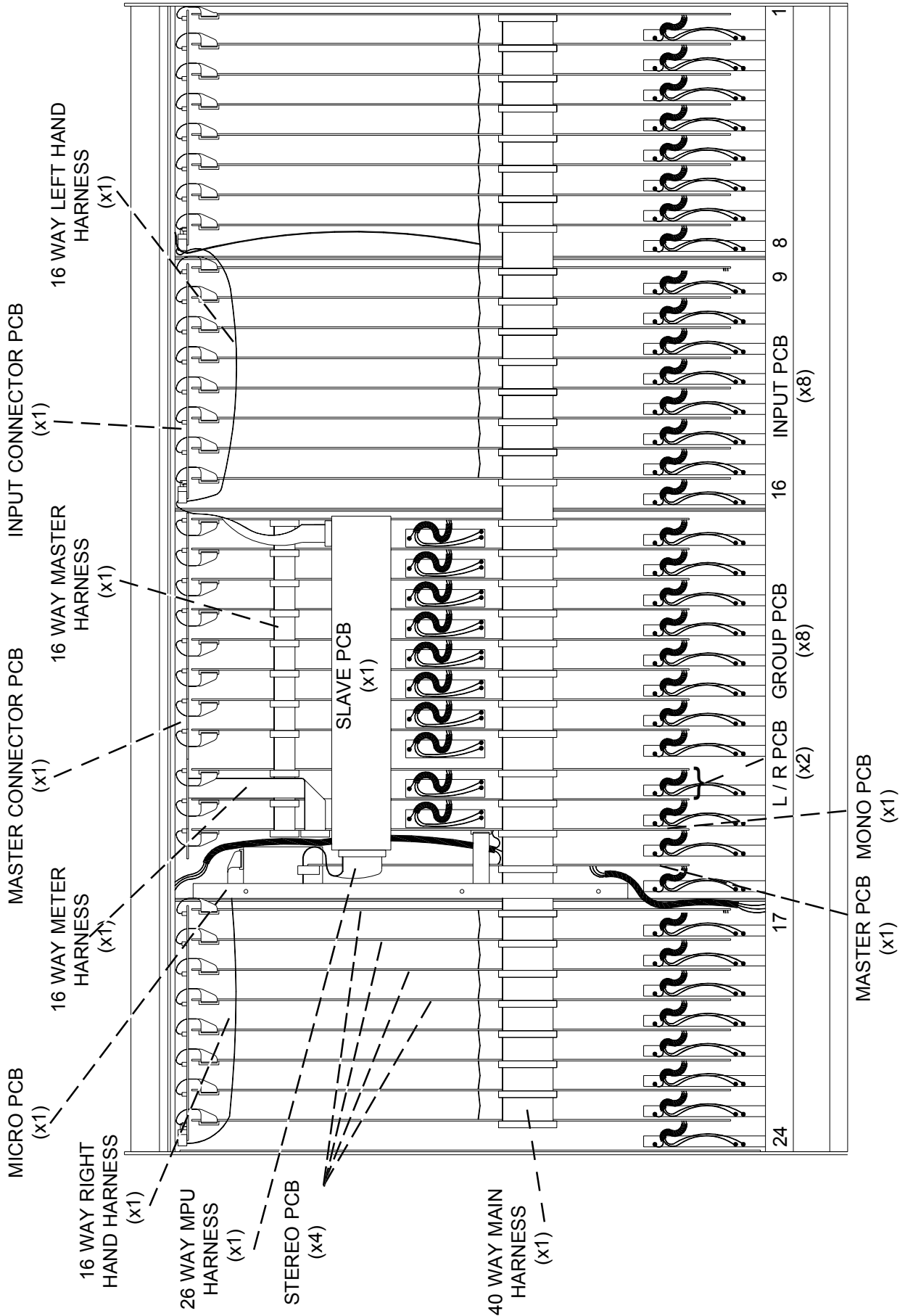

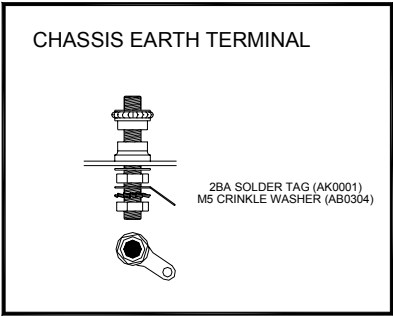

CONSOLE POWER WIRING

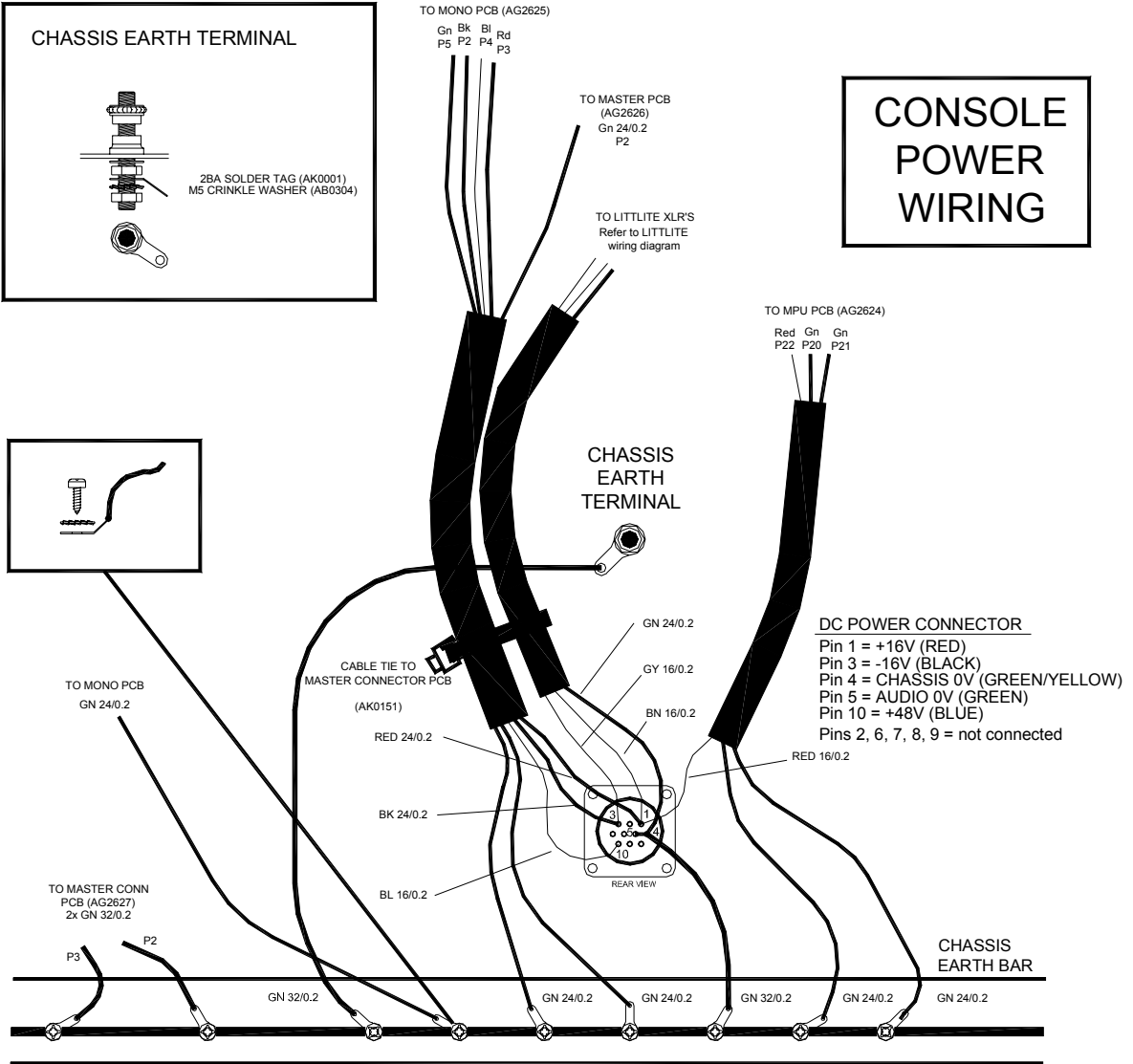

LITTLITE 4 PIN XLR WIRING

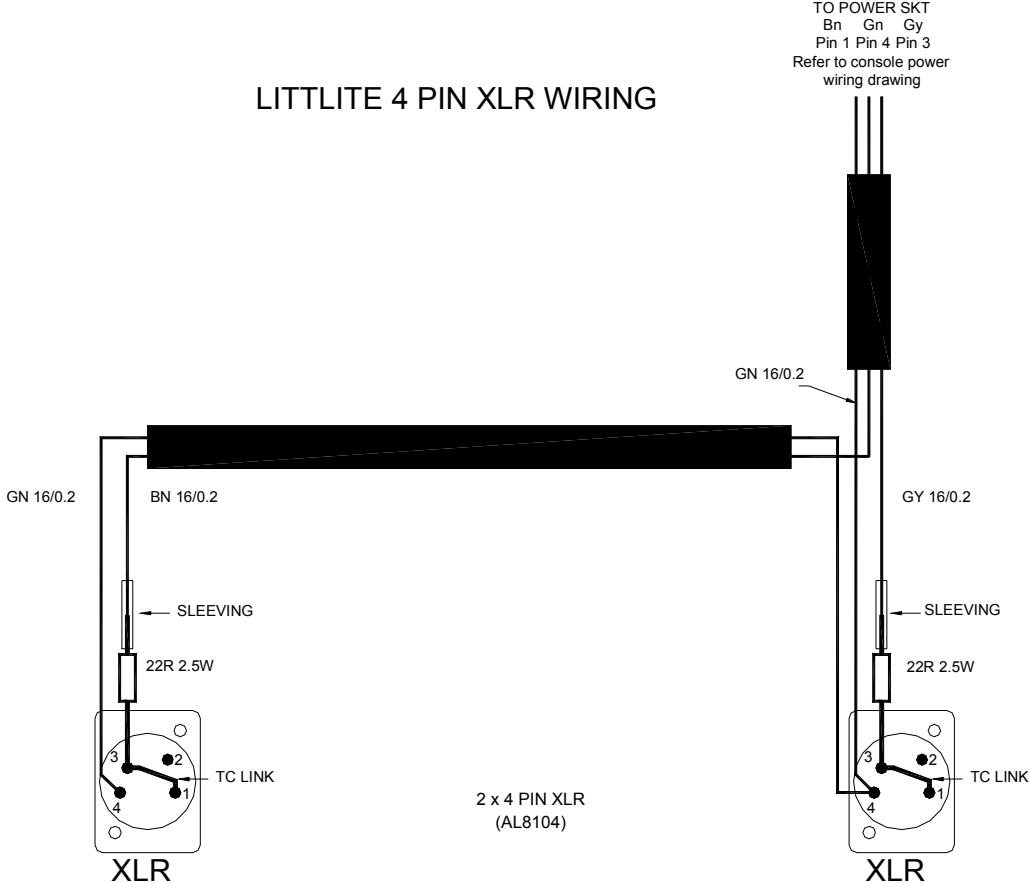

VIEW FROM BEHIND FRONT PANEL (CONSOLE UPSIDE DOWN)

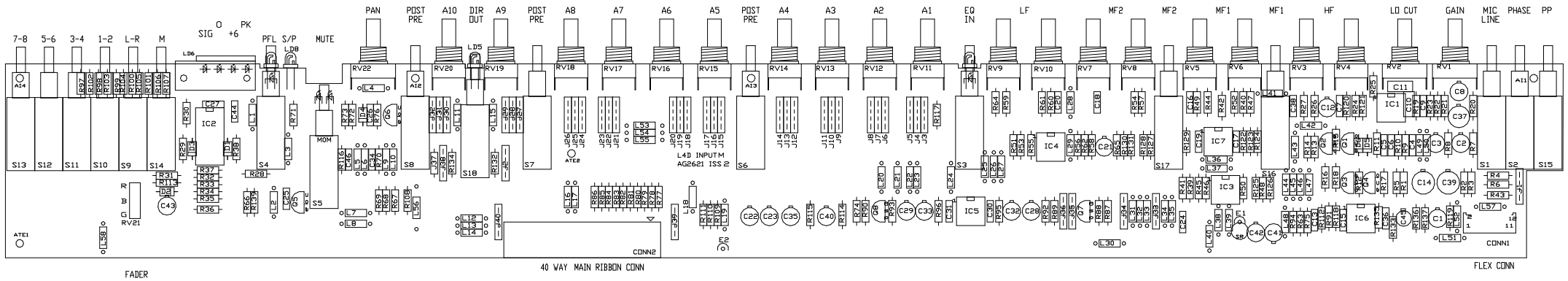

FADER

40 WAY MAIN RIBBON CONN

FLEX CONN

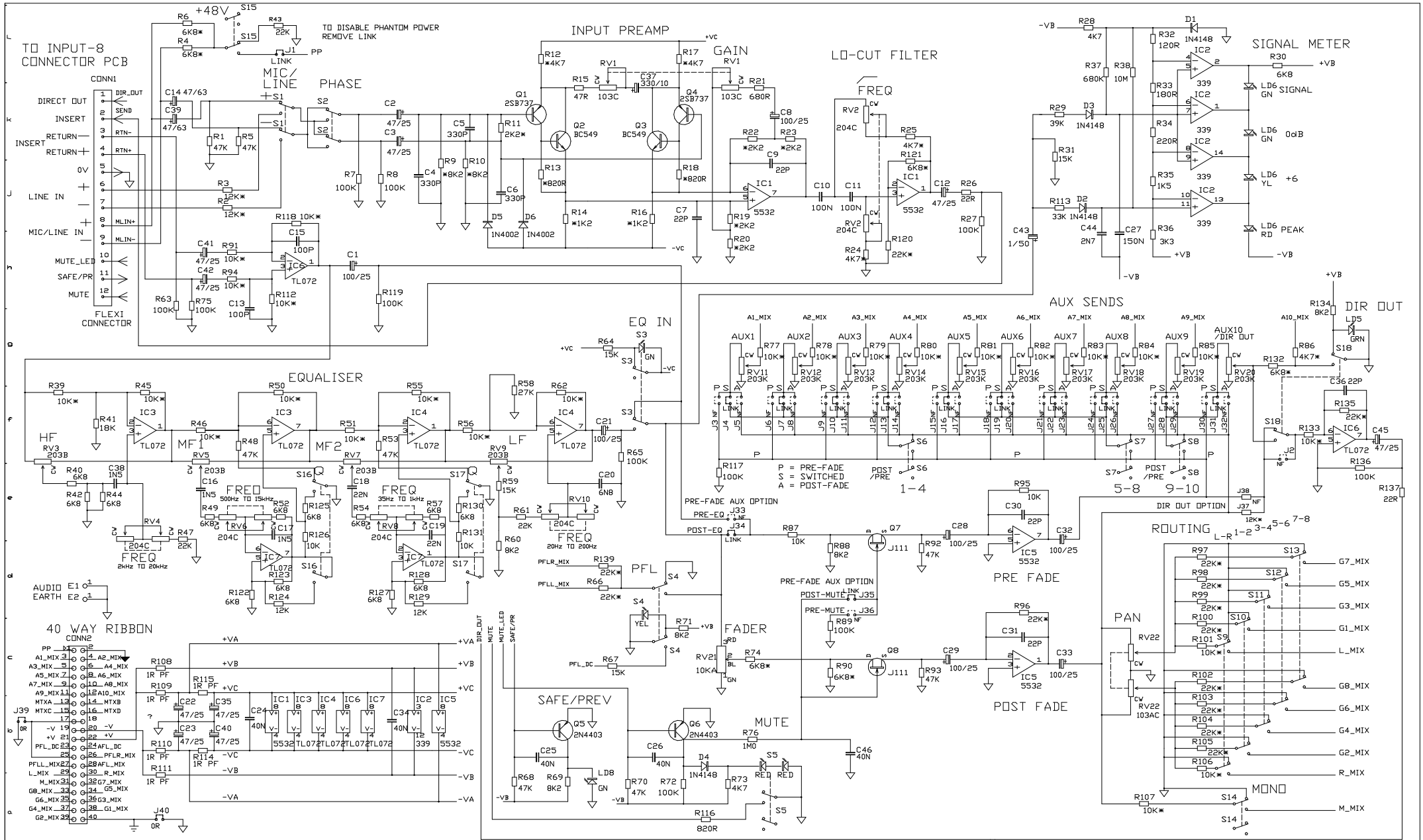

ISS	REVISION	BY	DATE	NOTES
A	DPICN	DRP	26-6-96	
B	UPDATES	DRP	17-7-96	
C	R32 WAS 100R	DRP	20-8-96	
1	S5 ALL SHOWN	DRP	17-10-96	
2	VALUE CORRECTION	DWD	29-10-96	

NOTES

- RESISTORS MARKED * ARE 1% ALL OTHERS ARE 5% 1/4W UNLESS OTHERWISE MARKED
- ELECTROLYTIC CAPACITORS ARE 7% VOLTS

UNIT TITLE
L4D

DRAWING TITLE
INPUT CIRCUIT DIAGRAM
PCB TYPE AG2621

MANUFACTURED IN ENGLAND BY
ALLEN & HEATH

DRAWING No. C2621 ISSUE 2 A1

AG2622 ISS 2 L4DINC8

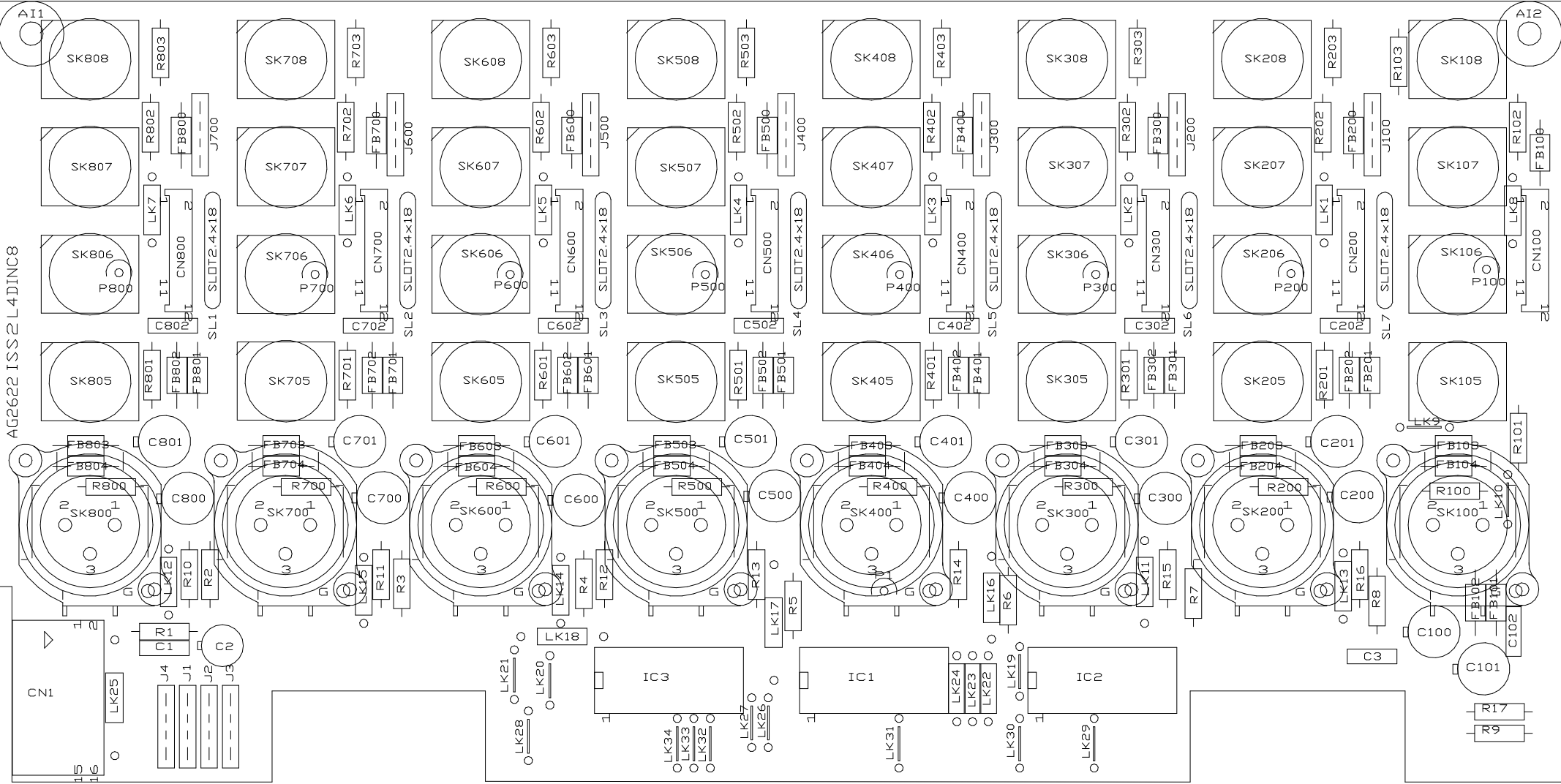

6R3R4R5R
 1L2L3L
 ASSIGNMENT
 LINKS

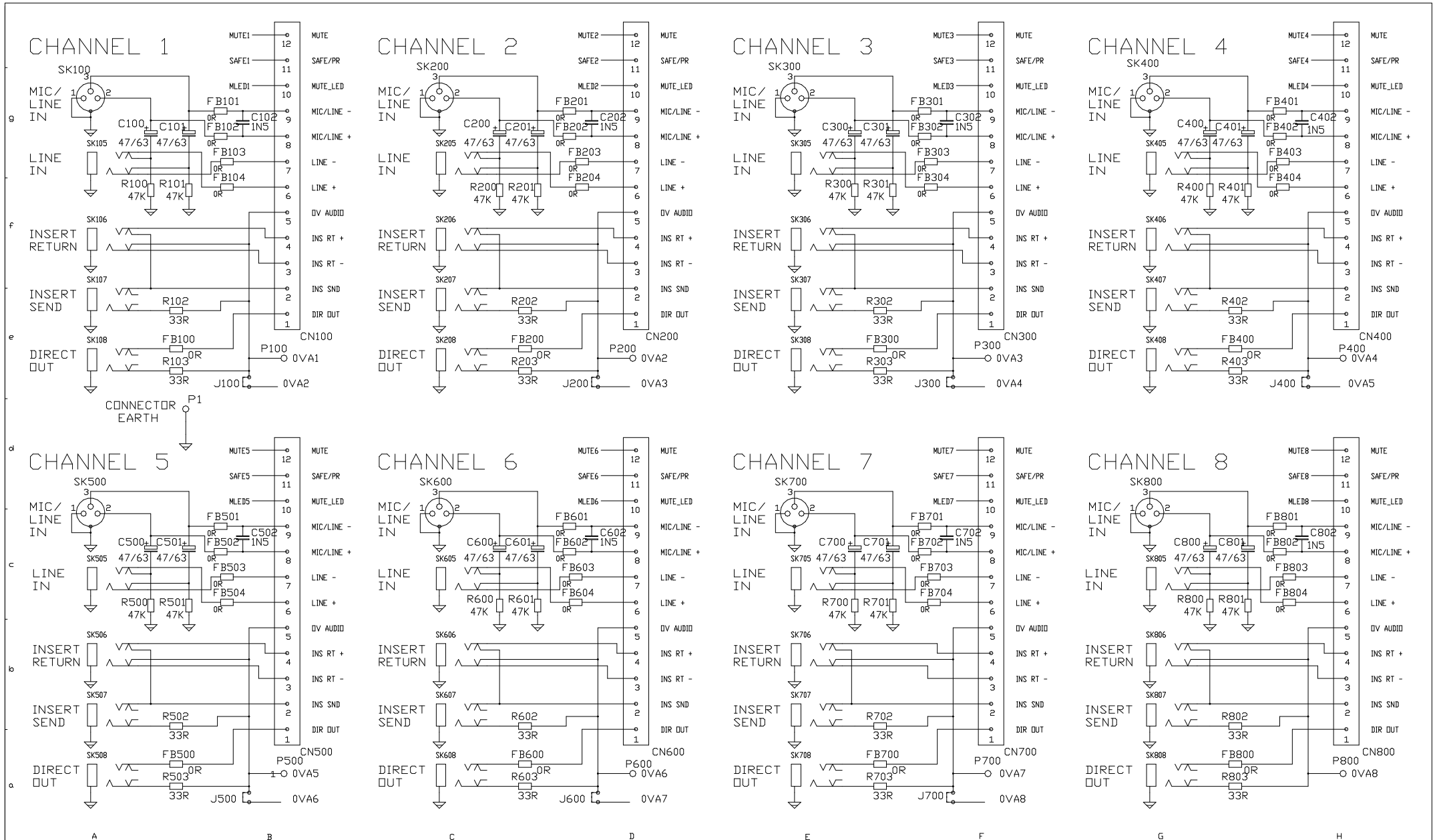

ISS.	REVISION	BY DATE	NOTES	UNIT TITLE	MANUFACTURED IN ENGLAND BY
A	ORIGIN	DLP 28-6-96	1. RESISTORS MARKED * ARE 1% ALL OTHERS ARE 5% 1/4W UNLESS OTHERWISE MARKED	L4D SHEET 1 OF 2	RG240
1	PRODUCTION	DRP17-10-96	2. ELECTROLYTIC CAPACITORS ARE 1% VOLTS	DRAWING TITLE	ALLEN & HEATH
2	C3 REF ADDED	DRP23-10-96		INPUT 8M CONNECTOR BOARD	DRAWING No. C2622
				CIRCUIT DIAGRAM	ISSUE 2
				PCB TYPE AG2622	A2

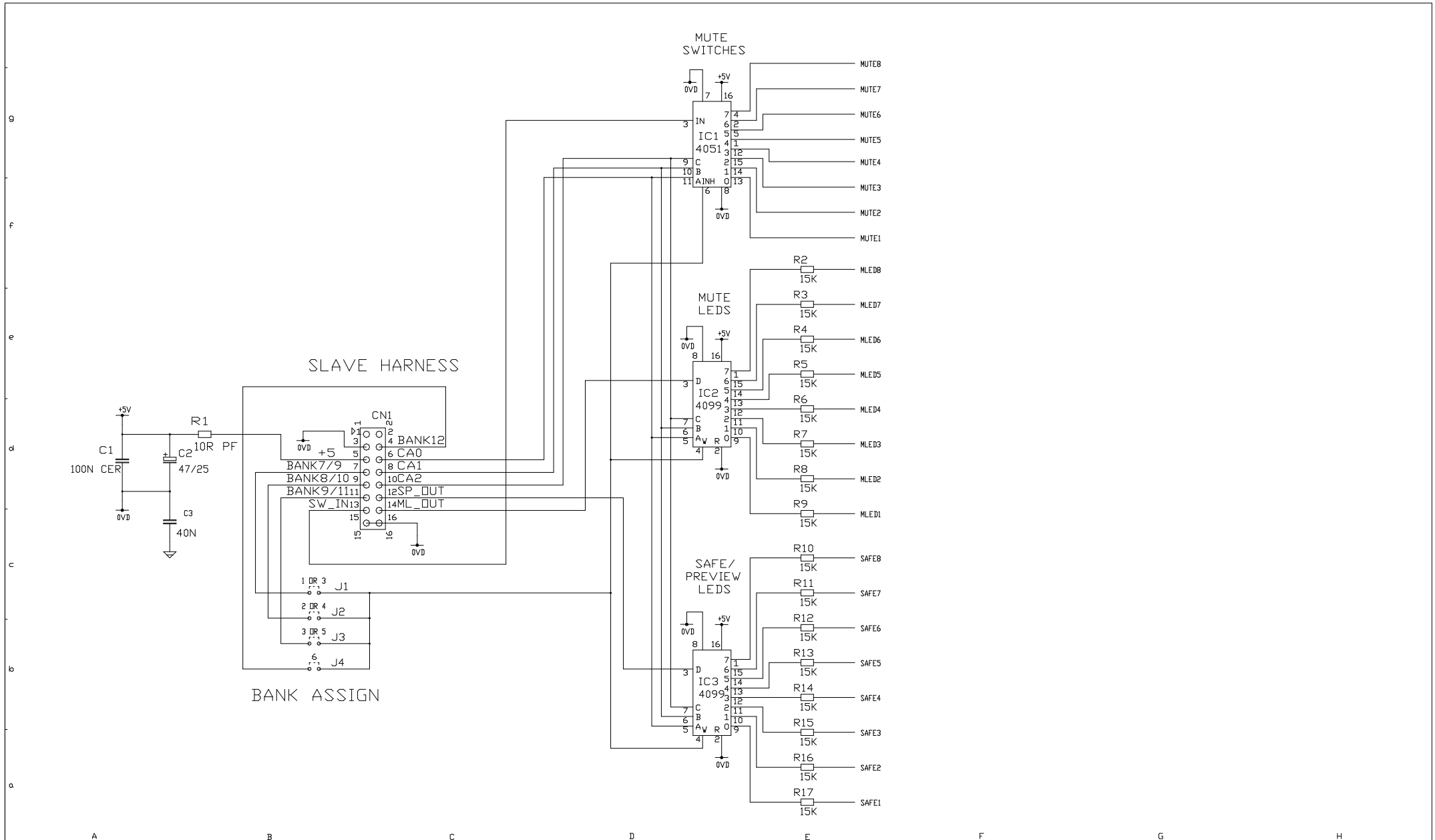

ISS.	REVISION	BY DATE	NOTES	UNIT TITLE	MANUFACTURED IN ENGLAND BY
A	ORIGIN	DLP 28-6-96	1. RESISTORS MARKED * ARE 1/2	L4D SHEET 2 OF 2	RG240
1	PRODUCTION	DRP17-10-96	ALL OTHERS ARE SZ 1/4W UNLESS OTHERWISE MARKED	DRAWING TITLE	ALLEN & HEATH
2	C3 REF ADDED	DRP23-10-96	2. ELECTROLYTIC CAPACITORS ARE 10V/VOLTS	INPUT 8M CONNECTOR BOARD	DRAWING No. C2622
				CIRCUIT DIAGRAM	ISSUE 2
				PCB TYPE AG2622	A2

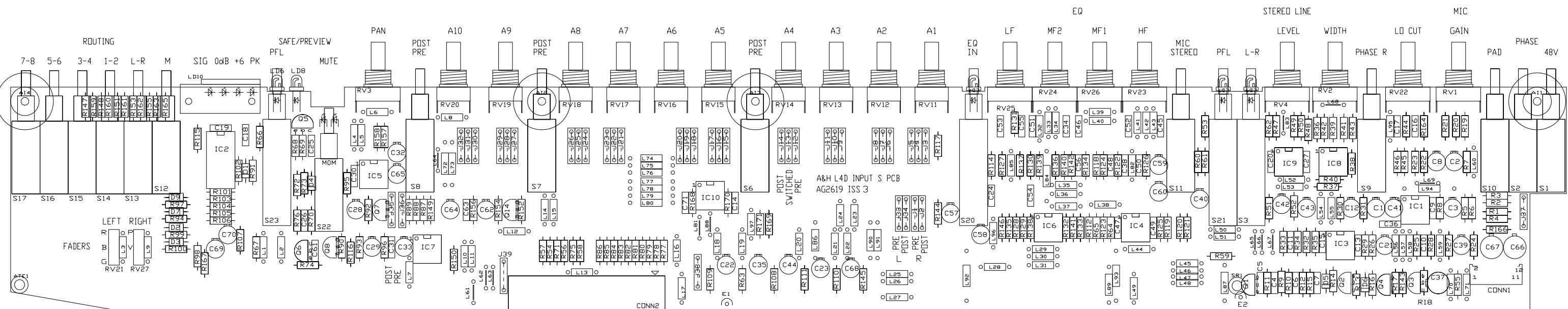

PRE-FADE AUX PRE/POST MUTE
LINK OPTION

40 WAY MAIN RIBBON

AUX PRE/POST
LINK OPTIONS

PRE-FADE AUX PRE/POST EQ
LINK OPTION

+48V PHANTOM POWER
LINK OPTION

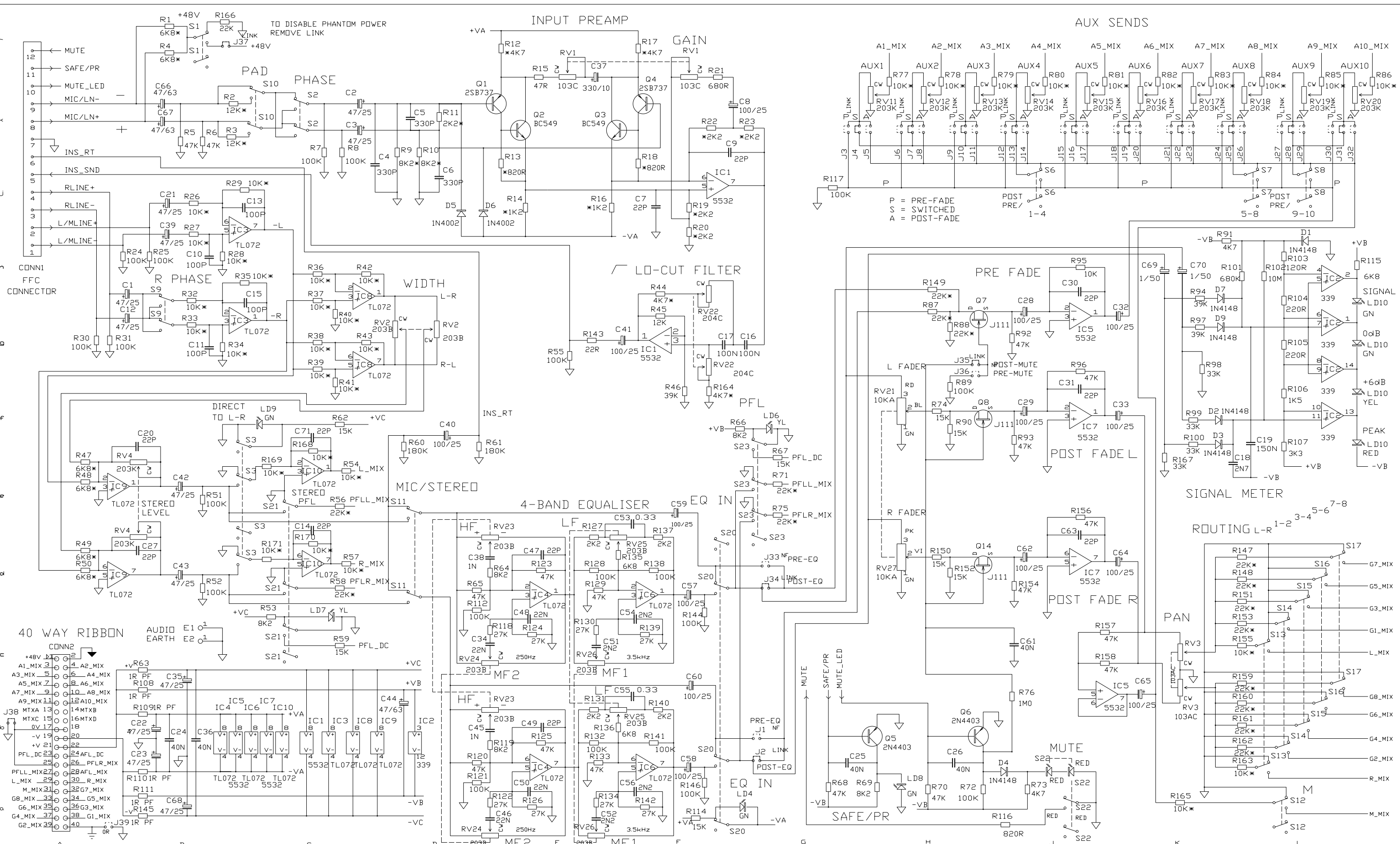

ISS	REVISION	BY	DATE	NOTES
A	ORIGIN	DLP	19-7-96	1. RESISTORS MARKED * ARE 1% ALL OTHERS ARE 5% 1/4W UNLESS OTHERWISE MARKED
B	VALUE CHANGES IC10+R+C ADDED	DRP	6-9-96	
C	PRODUCTION	DRP	17-10-96	2. ELECTROLYTIC CAPACITORS ARE 7V/VOLTS
D	BAR LED COLOURS ADDED	DRP	23-10-96	
E	PCB CHANGE	AAT	17-12-01	

UNIT TITLE	L4D	MANUFACTURED IN ENGLAND BY	RG240
DRAWING TITLE	STEREO INPUT CIRCUIT DIAGRAM		
PCB TYPE	AG2619		
DRAWING No.	C2619	ISSUE	3
			A1

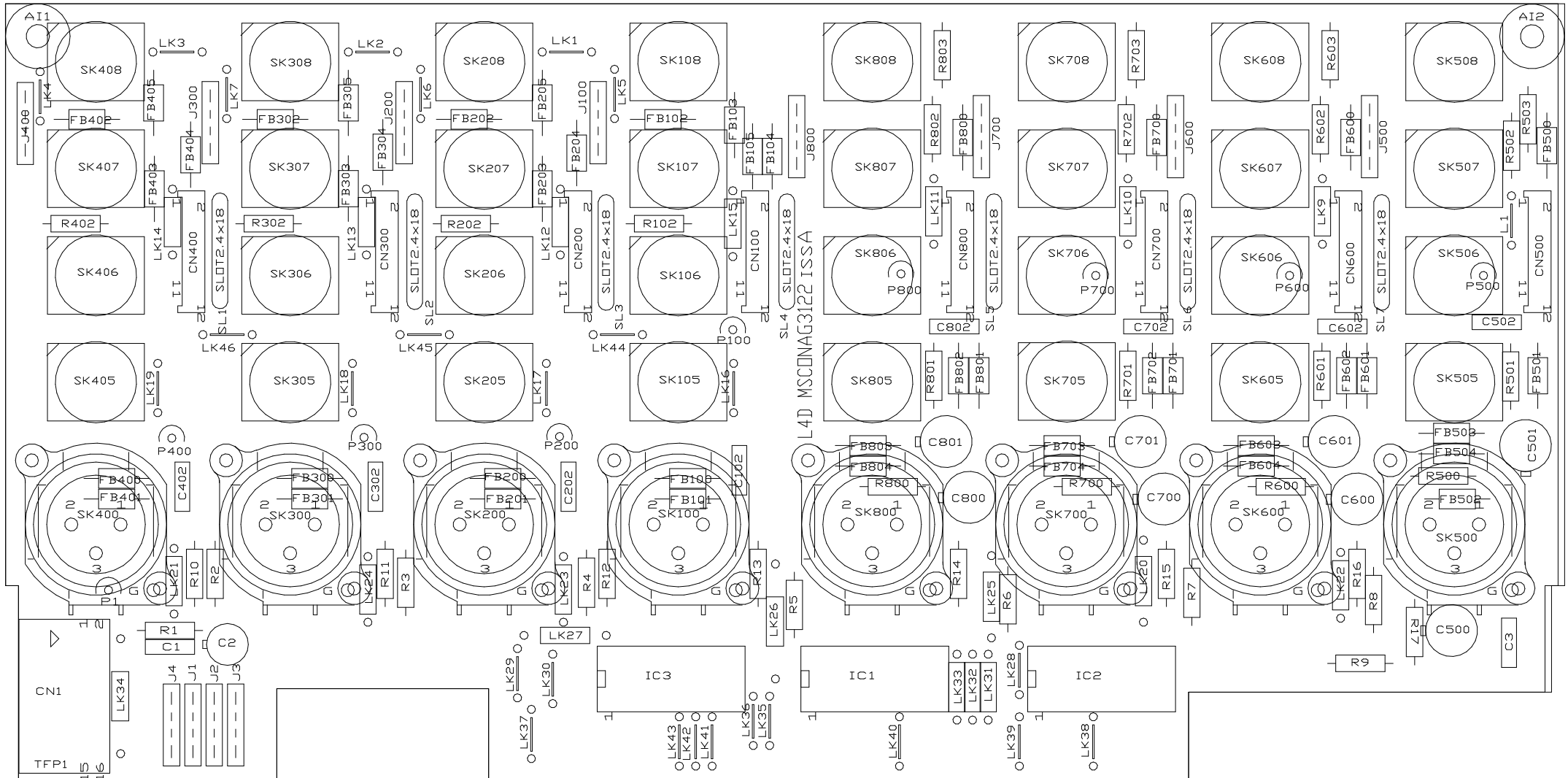

6R3R4R5R
 1L2L3L
 ASSIGNMENT LINKS

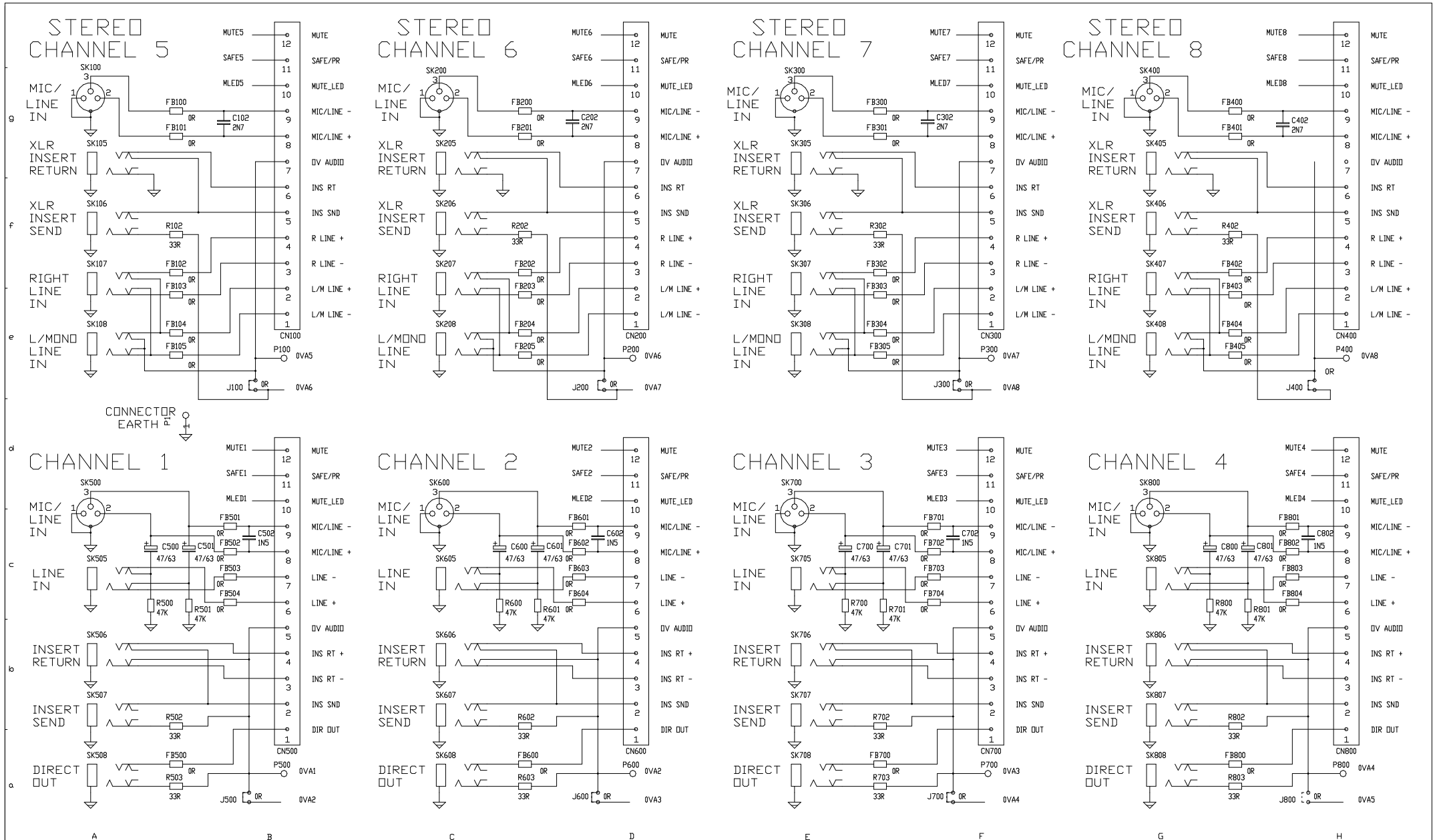

ISS.	REVISION	BY DATE	NOTES	UNIT TITLE	MANUFACTURED IN ENGLAND BY
A	ORIGIN	DRP 22-5-97	1. RESISTORS MARKED * ARE 1% ALL OTHERS ARE 5% 1/4W UNLESS OTHERWISE MARKED 2. ELECTROLYTIC CAPACITORS ARE 10V/VOLTS	L4D SHEET 1 OF 2 DRAWING TITLE INPUT 4MS CONNECTOR BOARD CIRCUIT DIAGRAM	RG240 ALLEN & HEATH DRAWING No. C3122 ISSUE A A2

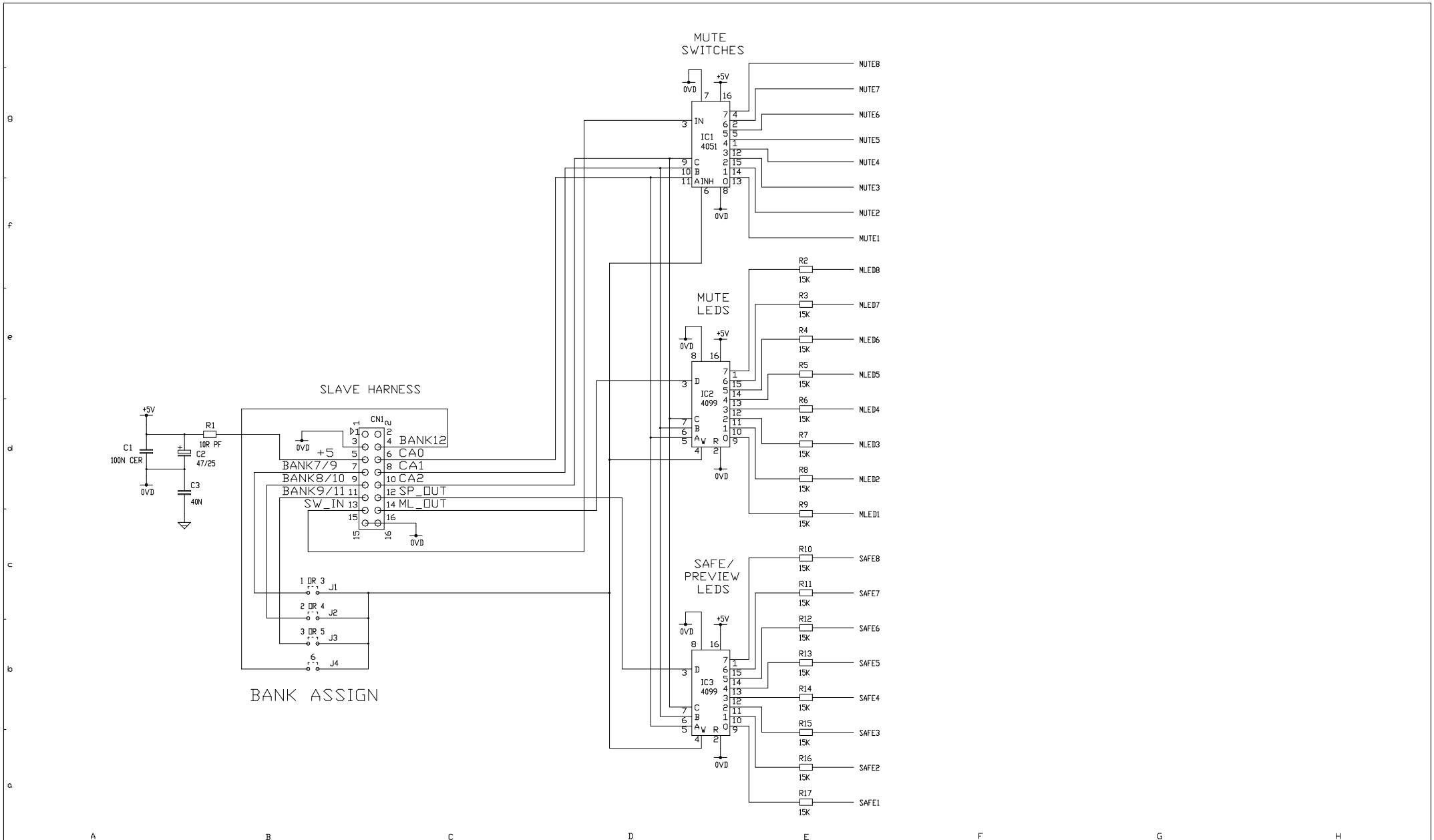

ISS.	REVISION	BY DATE	NOTES	UNIT TITLE	MANUFACTURED IN ENGLAND BY
A	ORIGIN	DRP 22-5-97	1. RESISTORS MARKED * ARE 1/2 ALL OTHERS ARE SZ 1/4W UNLESS OTHERWISE MARKED 2. ELECTROLYTIC CAPACITORS ARE 16V/VOLTS	L4D SHEET OF 2 DRAWING TITLE INPUT 4MS CONNECTOR BOARD CIRCUIT DIAGRAM AG3122	ALLEN & HEATH DRAWING No C3122 ISSUE A A2

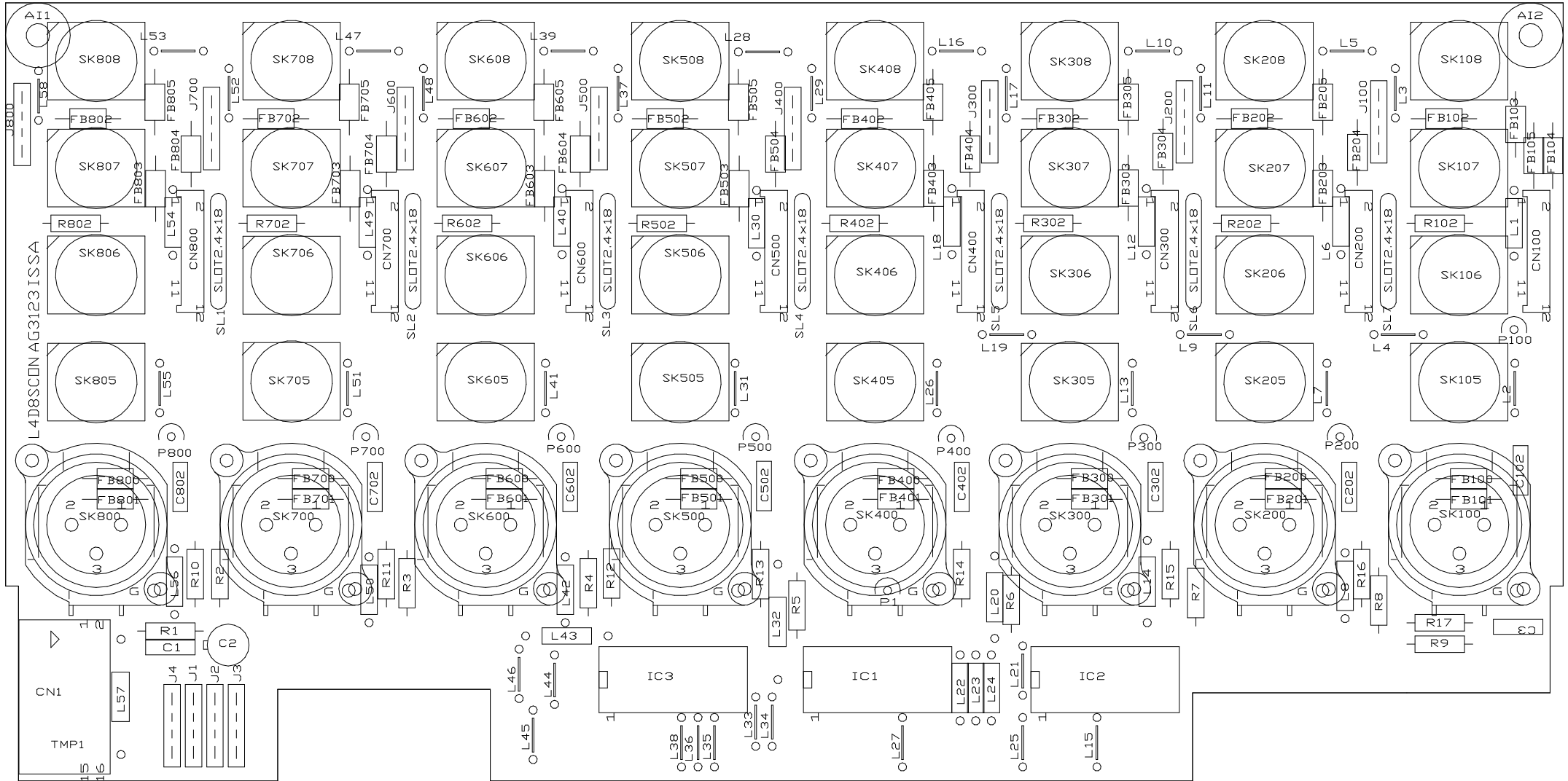

6R3R4R5R
 1L2L3L
 ASSIGNMENT LINKS

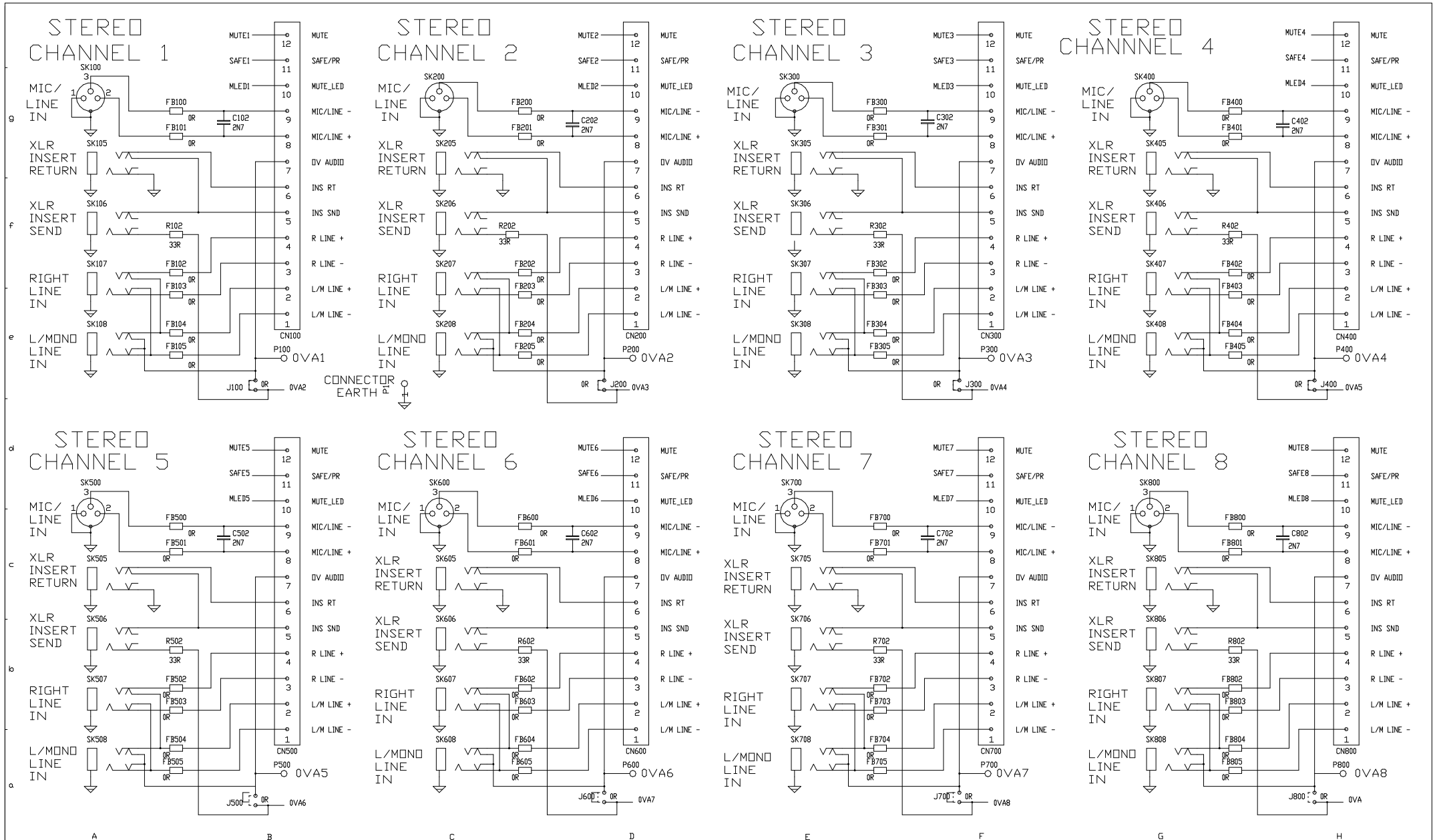

ISS.	REVISION	BY DATE	NOTES	UNIT TITLE	MANUFACTURED IN ENGLAND BY
A	ORIGIN	AAT23-05-97	1. RESISTORS MARKED * ARE 1% ALL OTHERS ARE SZ 1/4W UNLESS OTHERWISE MARKED 2. ELECTROLYTIC CAPACITORS ARE 1%VOLTS	L4D SHEET 1 OF 2	RG240
				DRAWING TITLE	ALLEN & HEATH
				INPUT 8S CONNECTOR BOARD	DRAWING No. C3123 ISSUE A A2
				CIRCUIT DIAGRAM	PCB TYPE AG3123

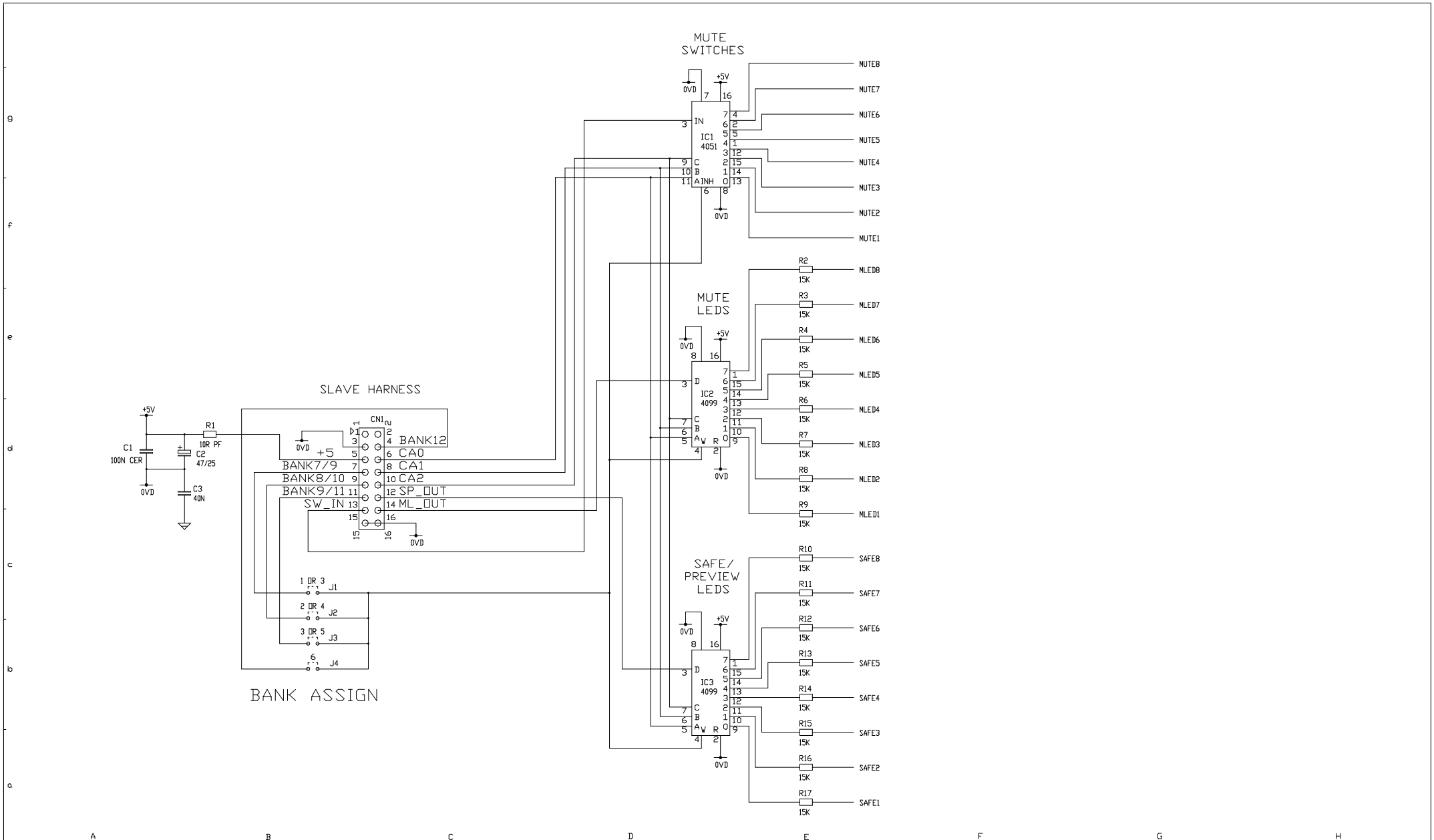

ISS.	REVISION	BY DATE	NOTES	UNIT TITLE	MANUFACTURED IN ENGLAND BY
A	ORIGIN	AAT23-05-97	1. RESISTORS MARKED * ARE 1/2 ALL OTHERS ARE SZ 1/4W UNLESS OTHERWISE MARKED 2. ELECTROLYTIC CAPACITORS ARE 16V/VOLTS	L4D SHEET OF 2 DRAWING TITLE INPUT 8S CONNECTOR BOARD CIRCUIT DIAGRAM PCB TYPE AG3123	RG240 ALLEN & HEATH DRAWING No. C3123 ISSUE A A2

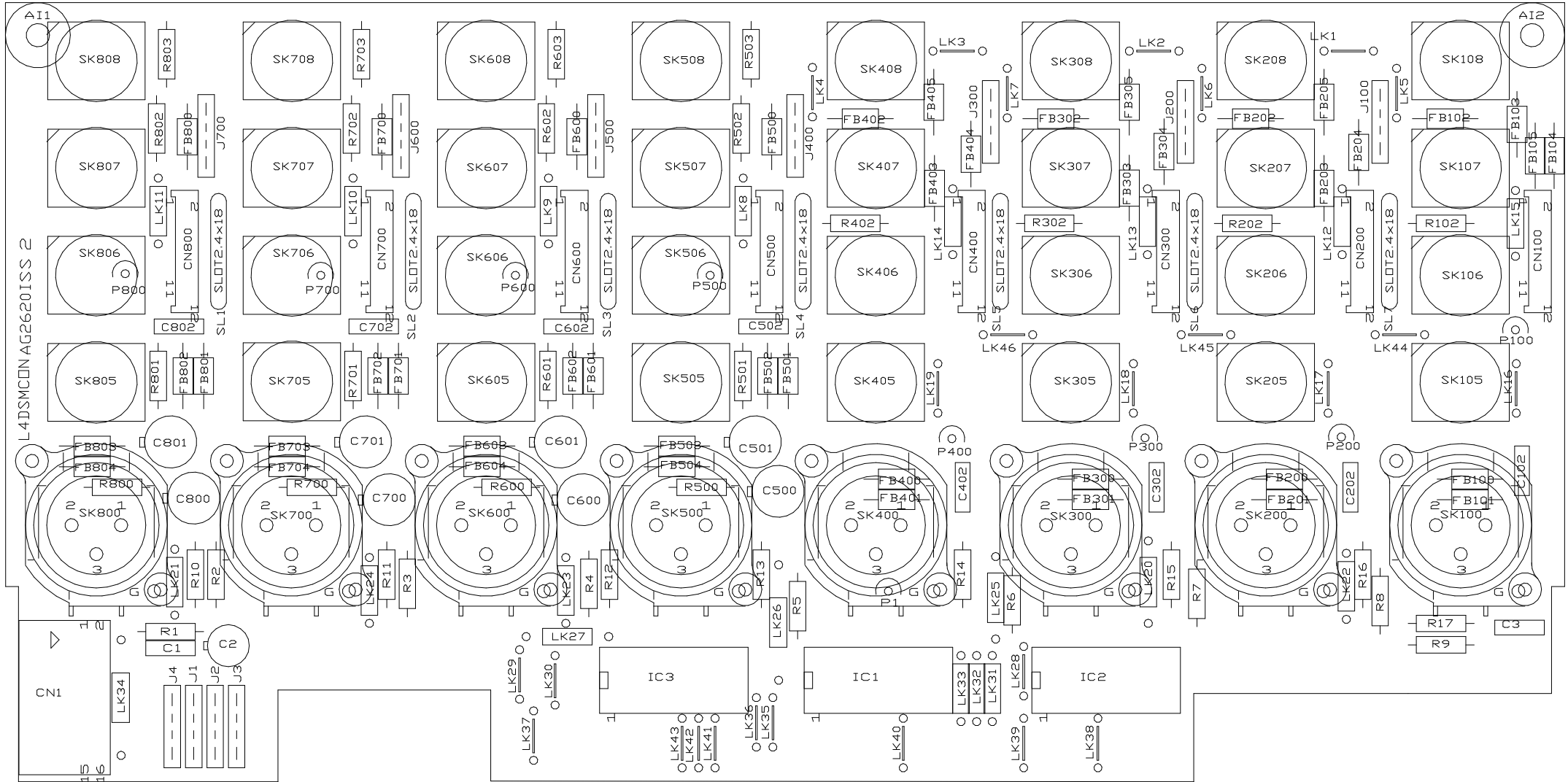

L4DSMCONAG2620ISS 2

6R3R4R5R
1L2L3L
ASSIGNMENT LINKS

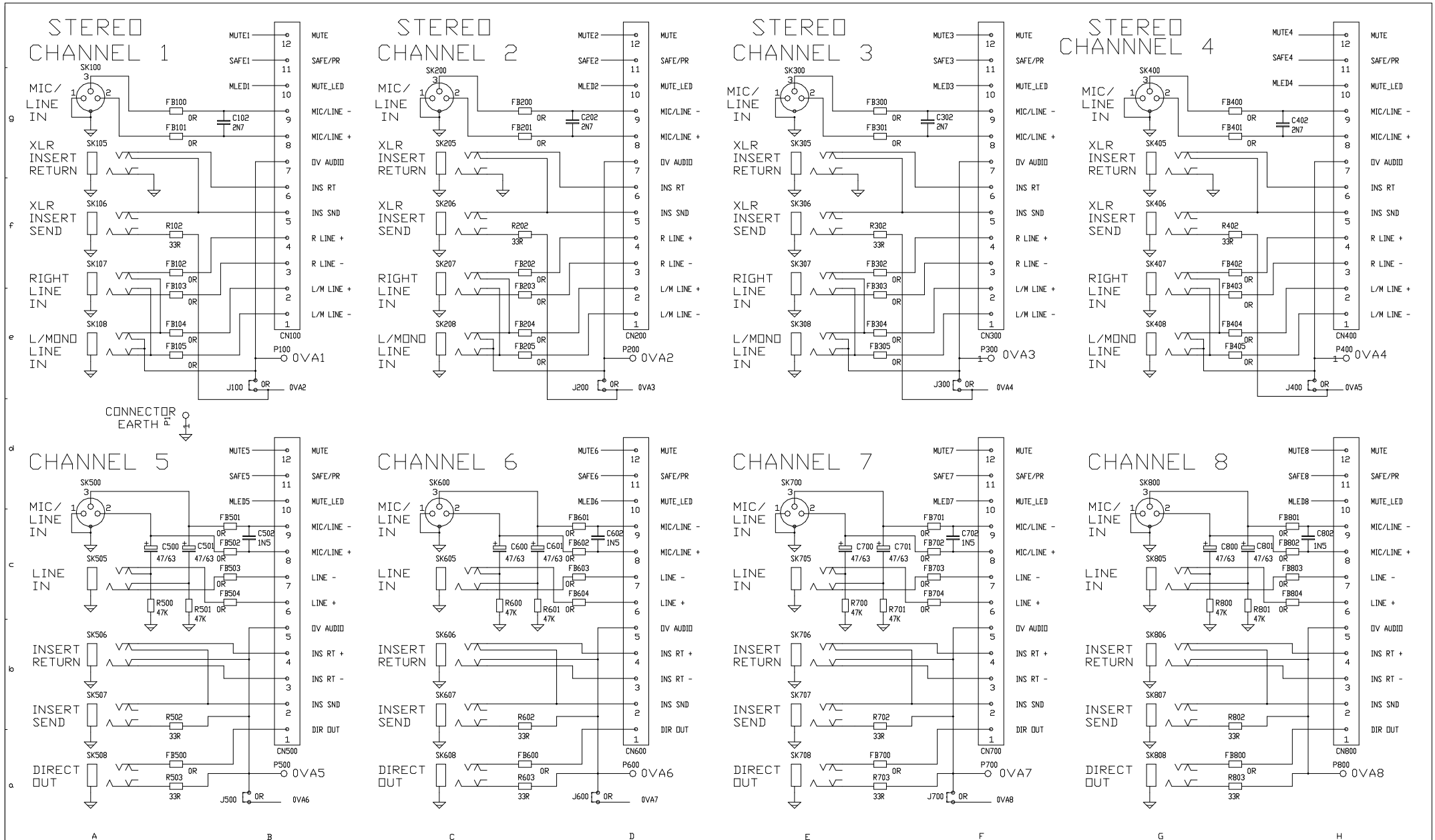

ISS.	REVISION	BY DATE	NOTES	UNIT TITLE	MANUFACTURED IN ENGLAND BY
A	ORIGIN	DLP 3/7/96	1. RESISTORS MARKED * ARE 1% ALL OTHERS ARE 5% 1/4W UNLESS OTHERWISE MARKED	L4D SHEET 1 OF 2	RG240
1	PRODUCTION	AAT18-10-96	2. ELECTROLYTIC CAPACITORS ARE 10V/VOLTS	DRAWING TITLE	ALLEN & HEATH
2	C3 ADDED TO 40N CAP	DRP23-10-96		INPUT 45M CONNECTOR BOARD CIRCUIT DIAGRAM PCB TYPE AG2620	DRAWING No. C2620 ISSUE 2

A2

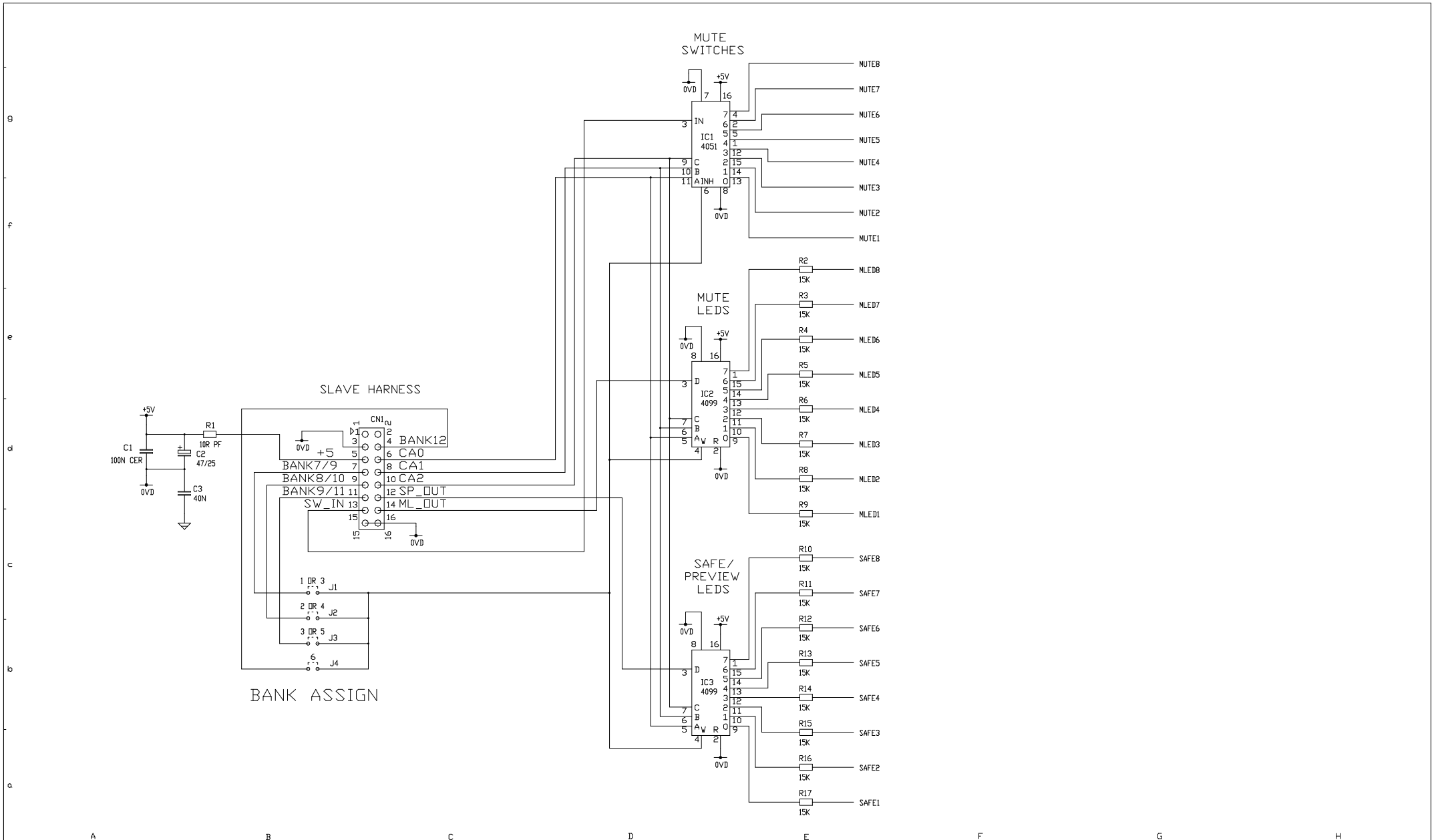

ISS.	REVISION	BY DATE	NOTES	UNIT TITLE	MANUFACTURED IN ENGLAND BY
A	ORIGIN	DLP 3/7/96	1. RESISTORS MARKED * ARE 1% ALL OTHERS ARE SZ 1/4W UNLESS OTHERWISE MARKED	L4D SHEET OF 2	RG240
1	PRODUCTION	AAT18-10-96	2. ELECTROLYTIC CAPACITORS ARE 16V/VOLTS	DRAWING TITLE	ALLEN & HEATH
2	C3 ADDED TO 40N CAP	DRP23-10-96		INPUT 4SM CONNECTOR BOARD CIRCUIT DIAGRAM PCB TYPE AG2620	DRAWING No. C2620 ISSUE 2

A2

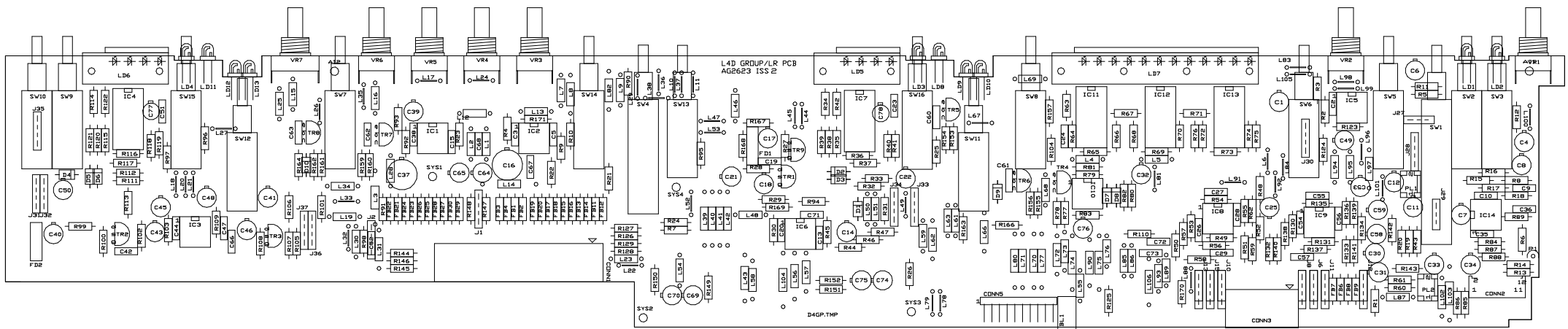

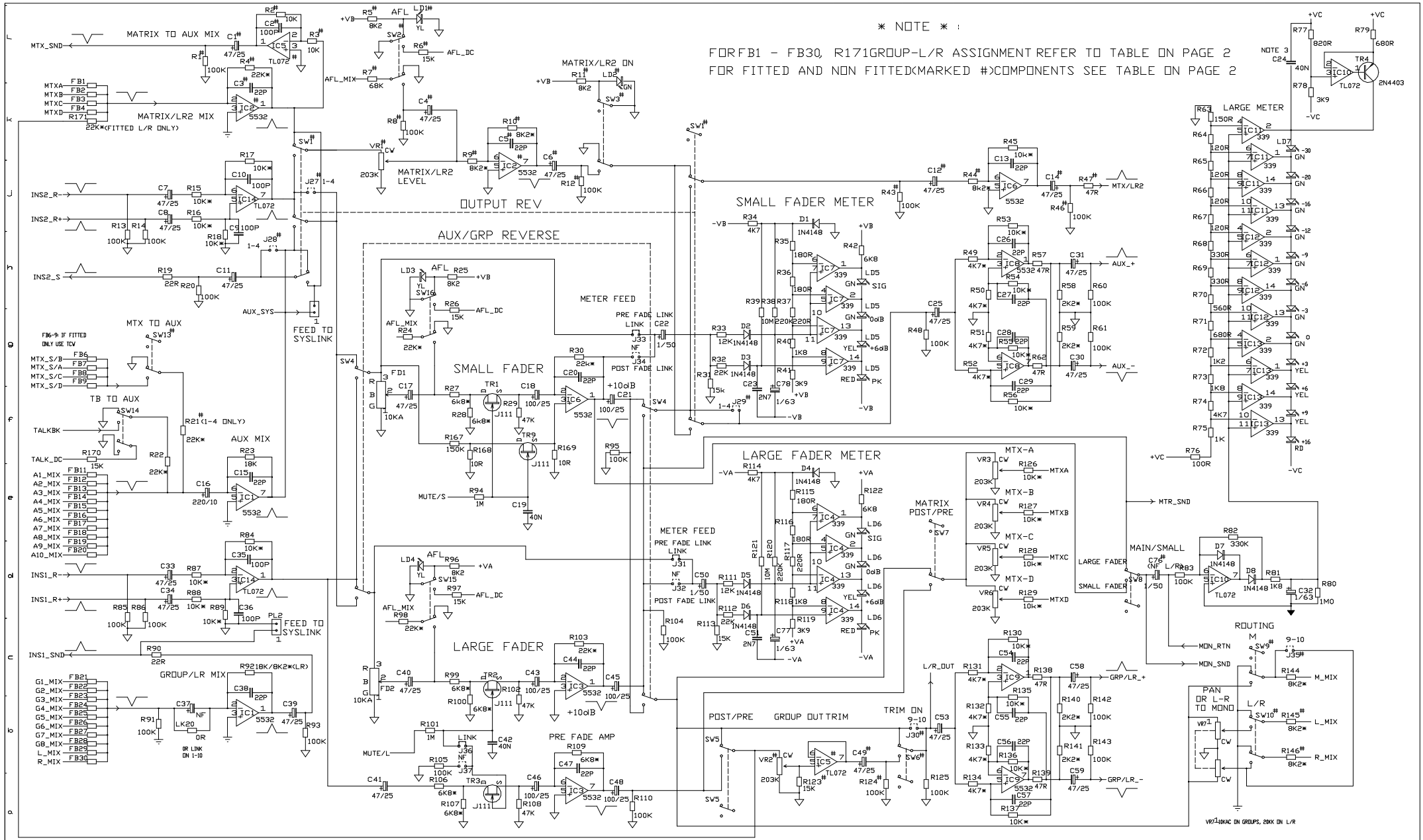

ISS.	REVISION	BY	DATE	NOTES
1	PRODUCTION	DRP	18-10-96	1. RESISTORS MARKED * ARE 1% ALL OTHERS ARE 5% 1/4W UNLESS OTHERWISE MARKED
2	LD7 COLOURS CHANGED	DRP	30-10-96	
3	R145, R150 FROM 100PF TO 1R PF	DWD	30-03-99	2. ELECTROLYTIC CAPACITORS ARE 10% TOL
4	C37 NF	DWD	21-01-00	3. CAP FITTED TO SOLDER SIDE ISSUE C PCB
5	R252 FROM 120R TO 100R	DWD	16-02-00	
6	METER GLD/W MOD.	DWD	20-06-00	

A	B	C	D	E	F	G	H	J	K	L
UNIT TITLE										
DRAWING TITLE										
PCB NUMBER										

UNIT TITLE	L4D		SHEET 1 OF 2
DRAWING TITLE	GROUP L/R PCB		
PCB NUMBER	PCB A2623		
MANUFACTURED IN ENGLAND BY	ALLEN & HEATH		
DRAWING No.	C2623	ISSUE	3.3 A1

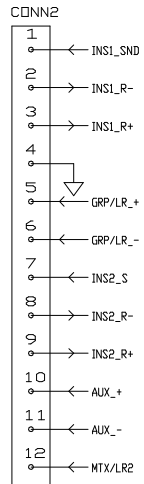

12 WAY FLEXILINK TO MASTER CONNECTOR PCB

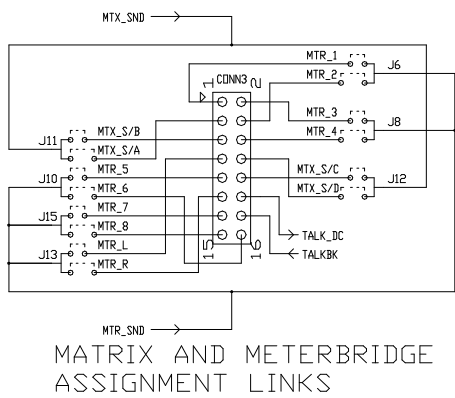

MATRIX AND METERBRIDGE ASSIGNMENT LINKS

GROUP BOARD ASSIGNMENT			
COMPONENT	1 - 4	5 - 8	9 - 10 (L+R)
FB1	NF	PDS 5 ONLY	NF
FB2	NF	PDS 6 ONLY	NF
FB3	NF	PDS 7 ONLY	NF
FB4	NF	PDS 8 ONLY	NF
FB6	PDS 2 ONLY	NF	NF
FB7	PDS 1 ONLY	NF	NF
FB8	PDS 3 ONLY	NF	NF
FB9	PDS 4 ONLY	NF	NF
FB11	PDS 1 ONLY	NF	NF
FB12	PDS 2 ONLY	NF	NF
FB13	PDS 3 ONLY	NF	NF
FB14	PDS 4 ONLY	NF	NF
FB15	NF	PDS 5 ONLY	NF
FB16	NF	PDS 6 ONLY	NF
FB17	NF	PDS 7 ONLY	NF
FB18	NF	PDS 8 ONLY	NF
FB19	NF	NF	PDS 9 ONLY
FB20	NF	NF	PDS 10 ONLY
FB21	PDS 1 ONLY	NF	NF
FB22	PDS 2 ONLY	NF	NF
FB23	PDS 3 ONLY	NF	NF
FB24	PDS 4 ONLY	NF	NF
FB25	NF	PDS 5 ONLY	NF
FB26	NF	PDS 6 ONLY	NF
FB27	NF	PDS 7 ONLY	NF
FB28	NF	PDS 8 ONLY	NF
FB29	NF	NF	PDS 9 ONLY
FB30	NF	NF	PDS 10 ONLY
R171	NF	NF	22K
J1	LINK	LINK	LINK
J2	NF	NF	NF
J6	PDS 1S - 2L	NF	NF
J8	PDS 3S - 4L	NF	NF
J10	NF	PDS 5S - 6L	NF
J11	NF	PDS 5L - 6S	NF
J12	NF	PDS 7S - 8L	NF
J13	NF	NF	PDS 9S - 10L
J15	NF	PDS 7S - 8L	NF
J27	LINK	NF	NF
J28	LINK	NF	NF
J29	LINK	NF	NF
J30	NF	NF	LINK
J31	LINK	LINK	LINK
J32	NF	NF	NF
J33	LINK	LINK	LINK
J34	NF	NF	LINK
J35	NF	NF	LINK
J36	LINK	LINK	LINK
J37	NF	NF	NF

	1-4	5-8	9-10
L8	NF	NF	NF
C1	NF	NF	NF
C2	NF	NF	NF
C3	NF	NF	NF
C4	NF	NF	NF
C5	NF	NF	NF
C6	NF	NF	NF
C12	NF	NF	NF
C14	NF	NF	NF
C37	NF	NF	NF
C49	NF	NF	NF
C67	NF	NF	NF
C76	NF	NF	NF
IC2	NF	NF	NF
IC5	NF	NF	NF
L9	NF	NF	NF
L13	NF	NF	NF
L74	NF	NF	NF
L75	NF	NF	NF
L82	NF	NF	NF
L83	NF	NF	NF
L86	NF	NF	NF
L94	NF	NF	NF
L97	NF	NF	NF
L100	NF	NF	NF
L101	NF	NF	NF
L102	NF	NF	NF
L103	NF	NF	NF
L104	NF	NF	NF
L105	NF	NF	NF
L106	NF	NF	NF
L107	NF	NF	NF
L108	NF	NF	NF
L109	NF	NF	NF
L110	NF	NF	NF
L111	NF	NF	NF
L112	NF	NF	NF
R1	NF	NF	NF
R2	NF	NF	NF
R3	NF	NF	NF
R4	NF	NF	NF
R5	NF	NF	NF
R6	NF	NF	NF
R7	NF	NF	NF
R8	NF	NF	NF
R9	NF	NF	NF
R10	NF	NF	NF
R11	NF	NF	NF
R12	NF	NF	NF
R21	NF	NF	NF
R43	NF	NF	NF
R44	NF	NF	NF
R46	NF	NF	NF
R47	NF	NF	NF
R123	NF	NF	NF
R124	NF	NF	NF
R145	NF	NF	NF
R146	NF	NF	NF
SW1	NF	NF	NF
SW2	NF	NF	NF
SW3	NF	NF	NF
SW6	NF	NF	NF
SW9	NF	NF	NF
SW10	NF	NF	NF
SW13	NF	NF	NF
VR1	NF	NF	NF
VR2	NF	NF	NF

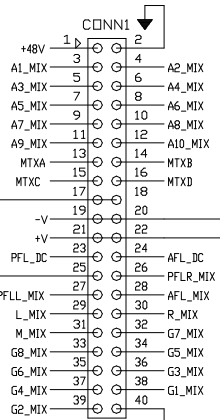

MAIN 40WAY CONNECTOR

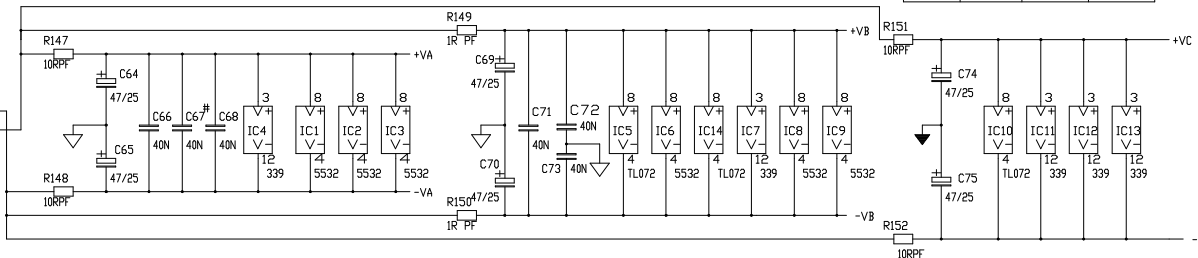

POWER SUPPLY FILTERING

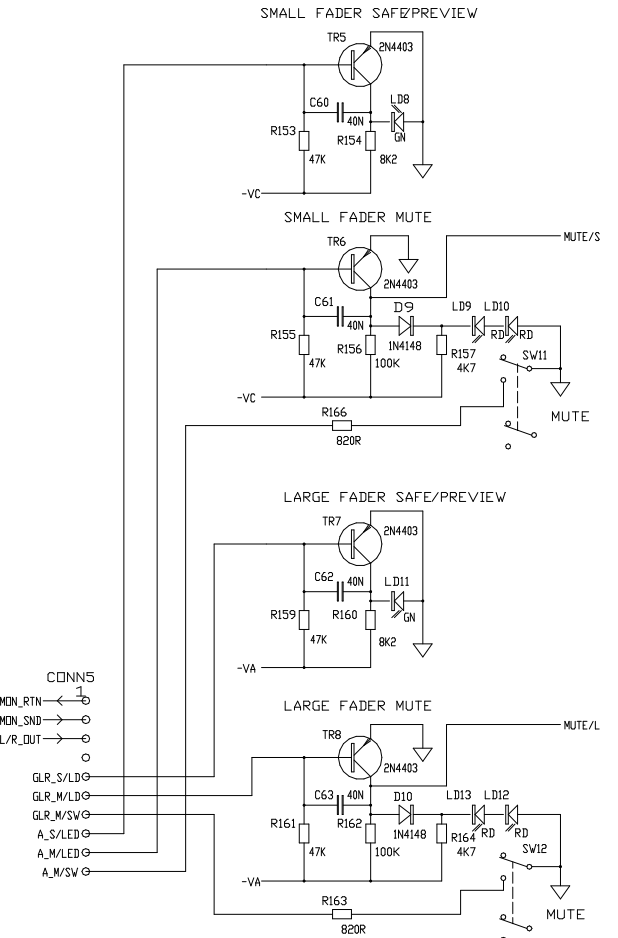

MUTE/SAFE CIRCUIT CONTROL FROM SLAVE CARD

ISS.	REVISION	BY DATE	NOTES	UNIT TITLE	SHEET 2 OF 2	MANUFACTURED IN ENGLAND BY	
1	PRODUCTION	DRP 18-10-96	1. RESISTORS MARKED * ARE 1% ALL OTHERS ARE 5% 1/4W UNLESS OTHERWISE MARKED	L4D		RG273	
2	LD7 COLOURS CHGD	DRP 30-10-96				ALLEN & HEATH	
3	R149, R150 FROM 10RPF TO 1R PF	DWD 30-03-99				DRAWING No. C2623	
3.1	C37 NF	DWD 21-01-00				ISSUE 3.3	
3.2	R35, R115 FROM 120R TO 180R	DWD 16-02-00				A2	
3.3	METER GLOW MOD.	DWD 20-06-00					

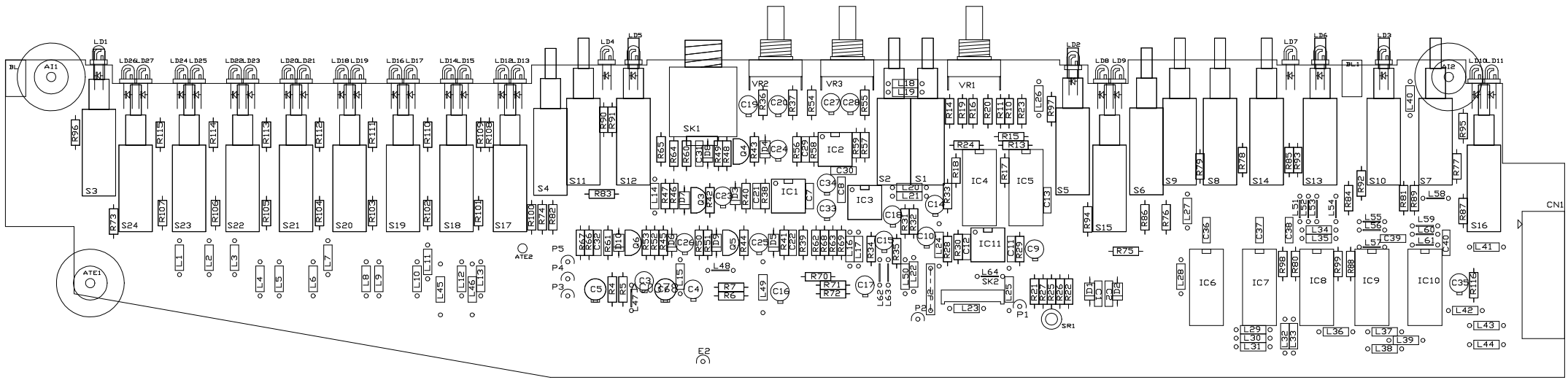

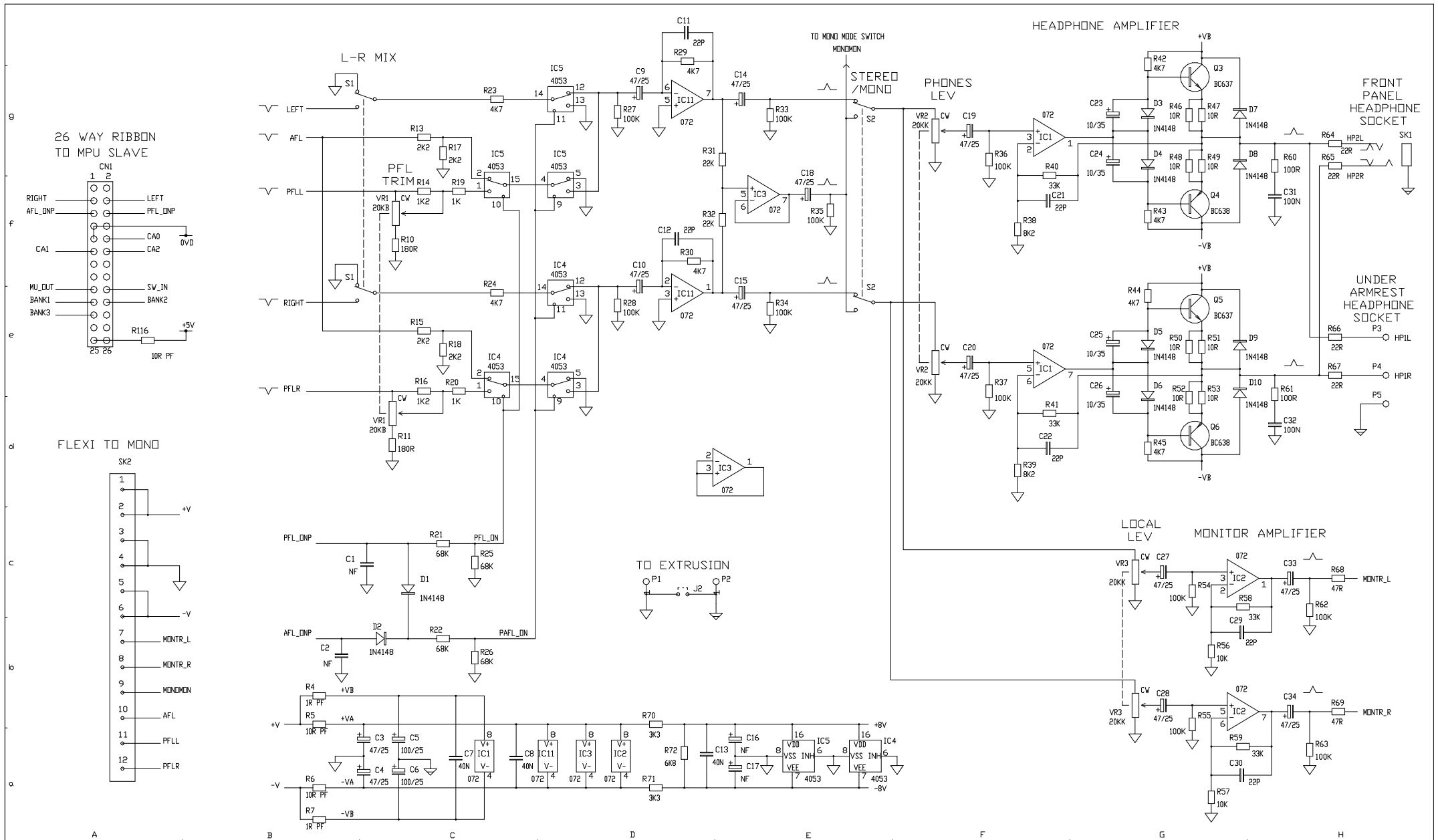

ISS.	REVISION	BY DATE	NOTES	UNIT TITLE	MANUFACTURED IN ENGLAND BY
A	ORIGIN	DLP 6-8-96	1. RESISTORS MARKED * ARE 1% ALL OTHERS ARE SZ 1/4W UNLESS OTHERWISE MARKED	L4D	ALLEN & HEATH
1	PRODUCTION	AA721-10-96	2. ELECTROLYTIC CAPACITORS ARE 7% VOLTAGE	MASTER CIRCUIT DIAGRAM	DRAWING No. C2626
2	VALUE CHANGES	DWD20-03-97		PCB TYPE AG2626	ISSUE 2

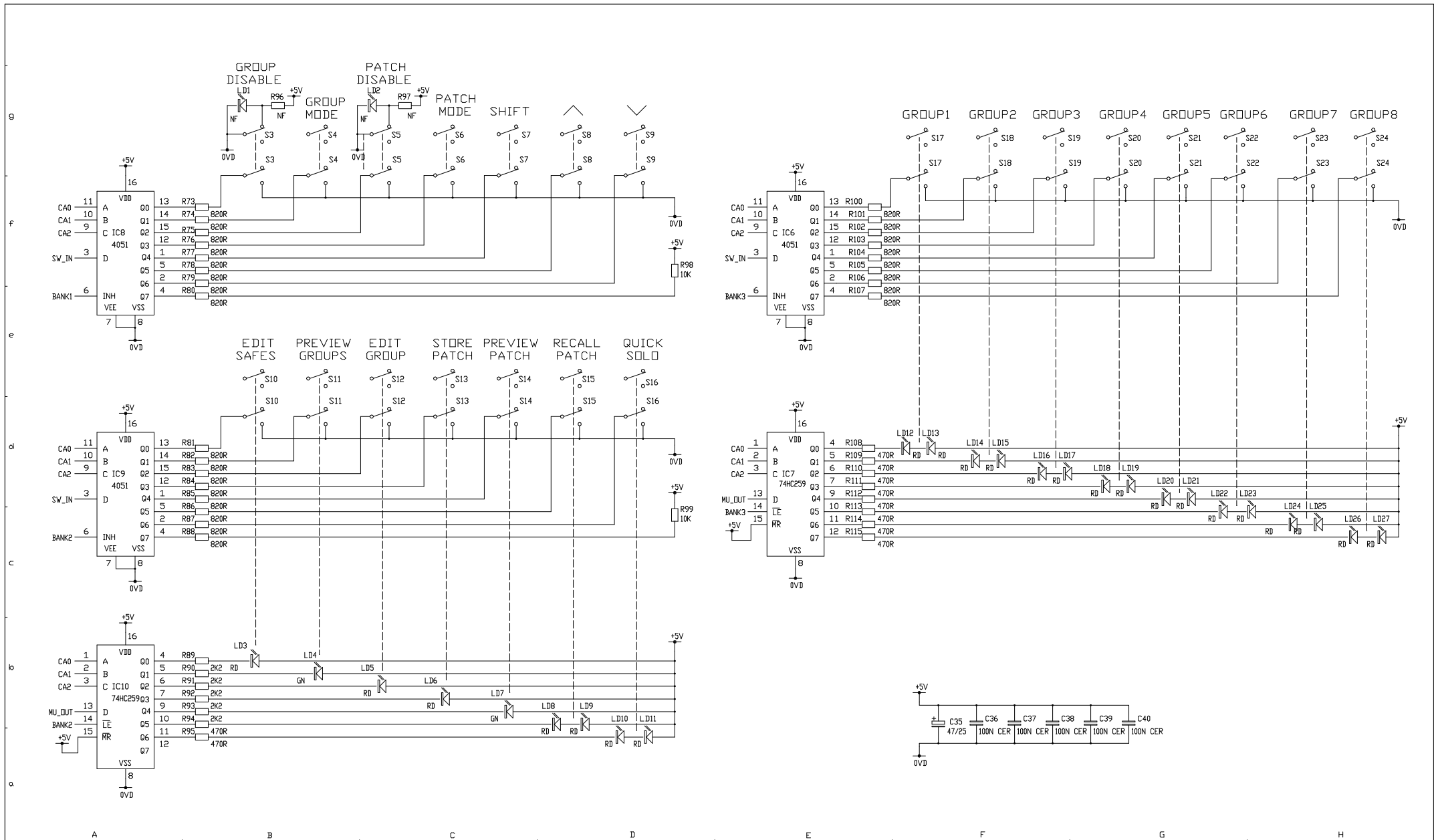

ISS.	REVISION	BY DATE	NOTES	UNIT TITLE	MANUFACTURED IN ENGLAND BY
A	ORIGIN	DLP 6-8-96	1. RESISTORS MARKED * ARE 1% ALL OTHERS ARE 5% 1/4W UNLESS OTHERWISE MARKED	L4D	ALLEN & HEATH
1	PRODUCTION	AA121-10-96	2. ELECTROLYTIC CAPACITORS ARE 1% VOLTS	PAGE 2 OF 2	
2	VALUE CHANGES	DWD20-03-97		DRAWING TITLE	DRAWING No. C2626 ISSUE 2
				MASTER CIRCUIT DIAGRAM	A2
				PCB TYPE AG2626	

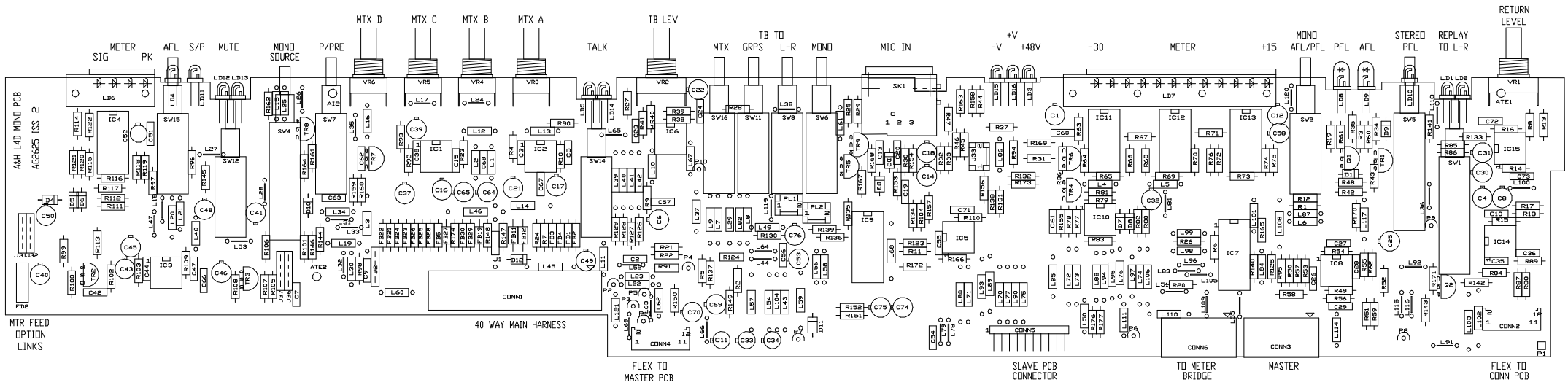

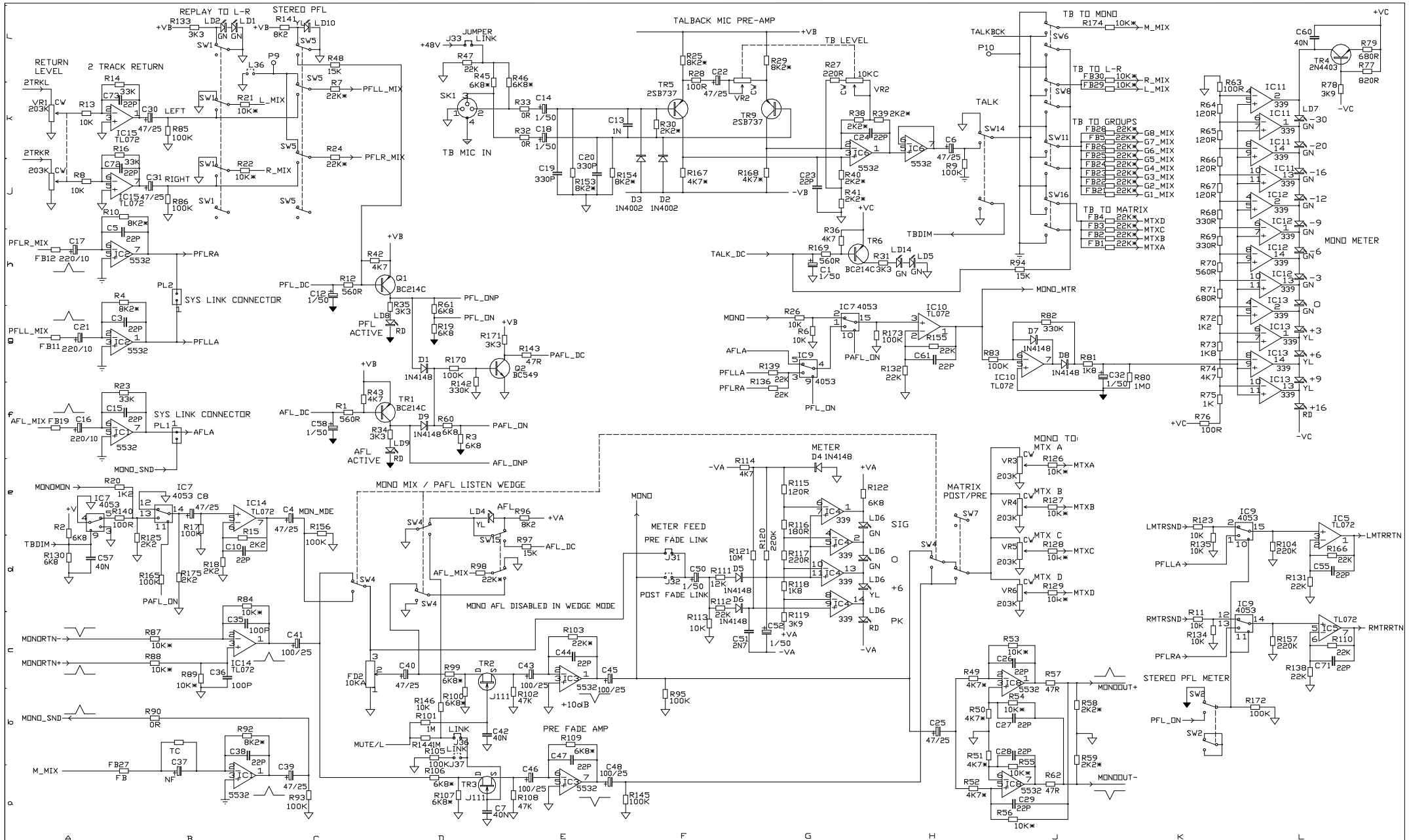

ISS	REVISION	BY	DATE	NOTES
1	PRODUCTION	DRP18-10-96		1. RESISTORS MARKED * ARE 1% ALL OTHERS ARE 5% 1/4W UNLESS OTHERWISE MARKED
2	UPDATES	DLP26-11-96		
3	VALUE CHANGES	DWD20-03-97		2. ELECTROLYTIC CAPACITORS ARE 7F/VOLTS
3.1	C37 NF	DWD21-01-00		

UNIT TITLE	SHEET 1 OF 2	MANUFACTURED IN ENGLAND BY
L4D		ALLEN & HEATH
DRAWING TITLE	MONO PCB	DRAWING No. C2625 ISSUE 3.1A1
	PCB TYPE AG2625	

UNIT TITLE	SHEET 1 OF 2	MANUFACTURED IN ENGLAND BY
L4D		ALLEN & HEATH
DRAWING TITLE	MONO PCB	DRAWING No. C2625 ISSUE 3.1A1
	PCB TYPE AG2625	

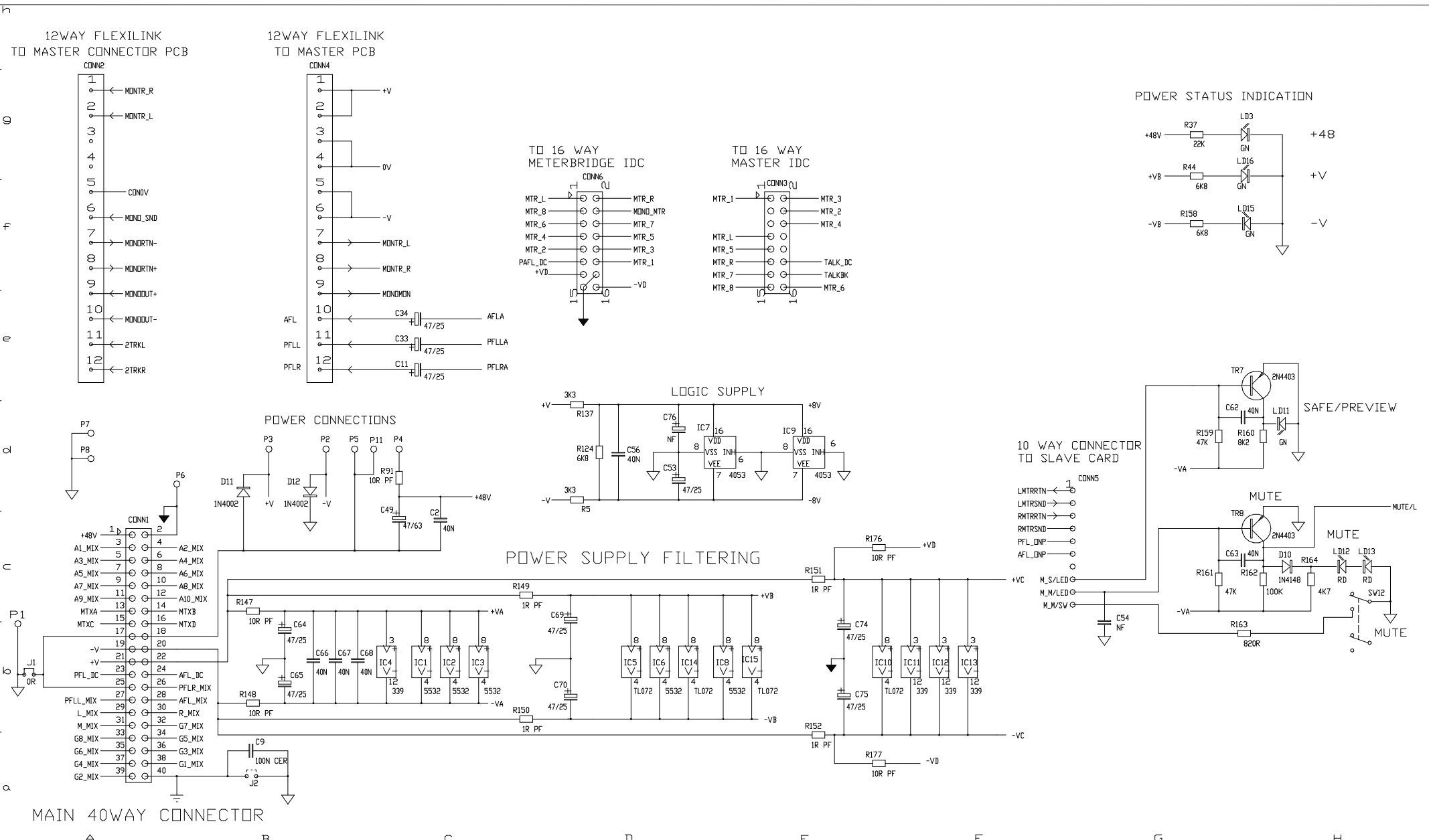

ISS.	REVISION	BY DATE	NOTES	UNIT TITLE	SHEET 2 OF 2	MANUFACTURED IN ENGLAND BY
1	PRODUCTION	DRP18-10-96	1. RESISTORS MARKED * ARE 1%	L4D		ALLEN & HEATH
2	UPDATES	DLP26-11-96	ALL OTHERS ARE 5% 1/4W UNLESS OTHERWISE MARKED	DRAWING TITLE		
3	VALUE CHANGES	DWD20-03-97	2. ELECTROLYTIC CAPACITORS ARE ?F/VOLTS	MONO PCB	PCB TYPE AG2625	DRAWING No. C2625 ISSUE 3.1 A2
3.1	C37 NF	DWD21-01-00				

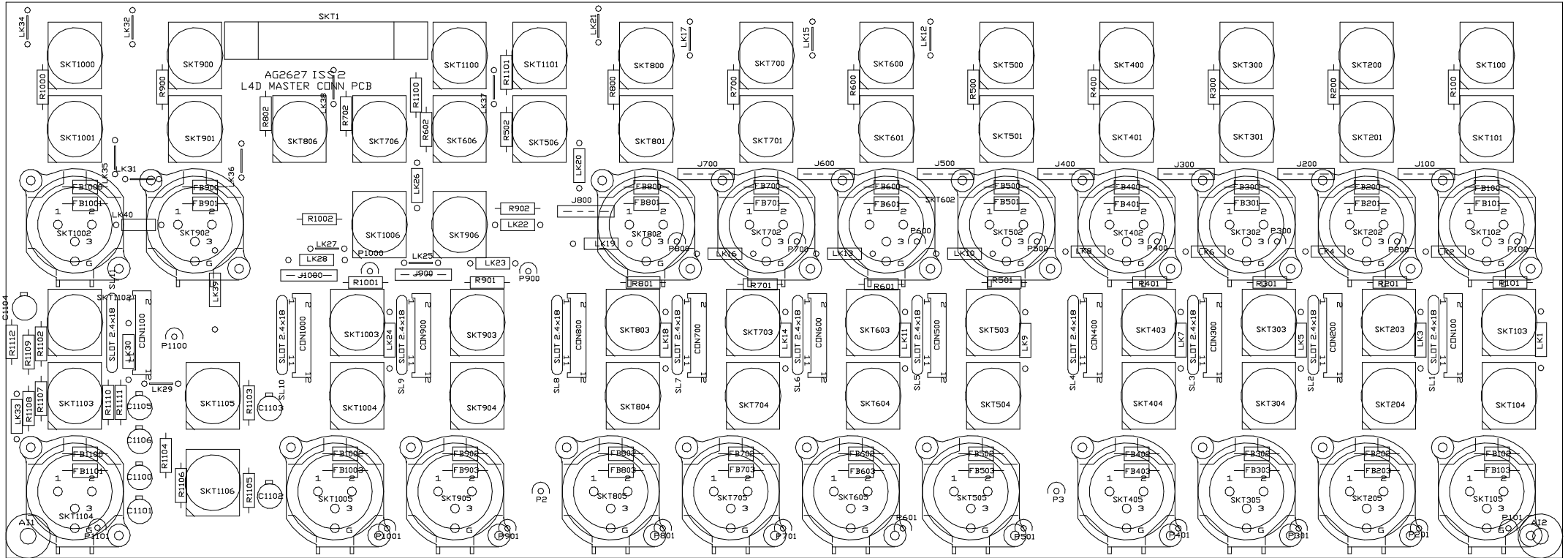

GROUP CHANNEL 1

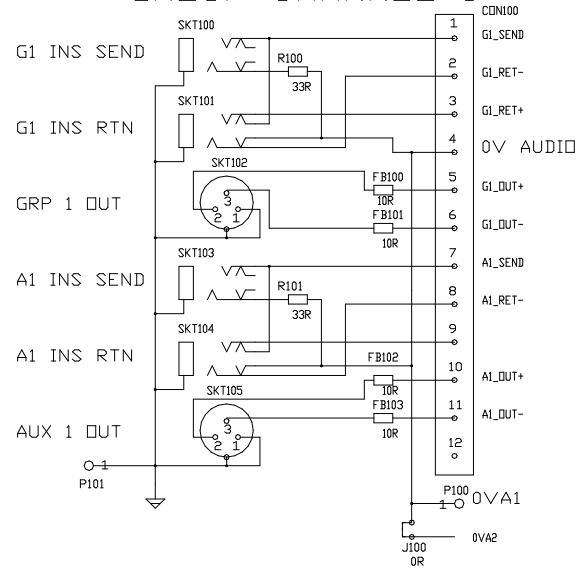

GROUP CHANNEL 2

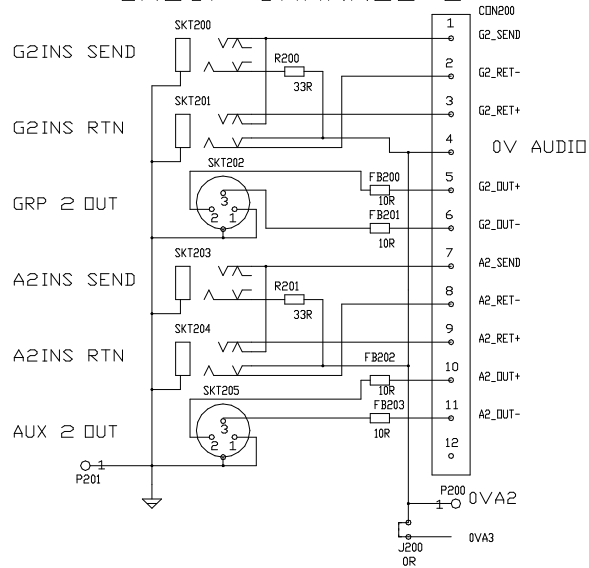

GROUP CHANNEL 3

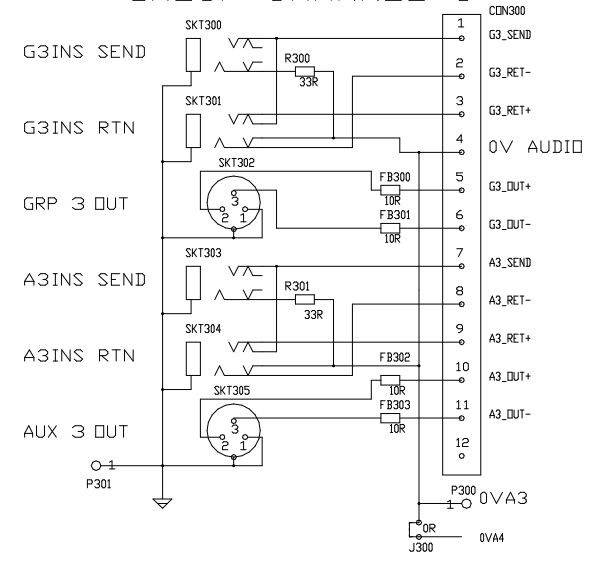

GROUP CHANNEL 4

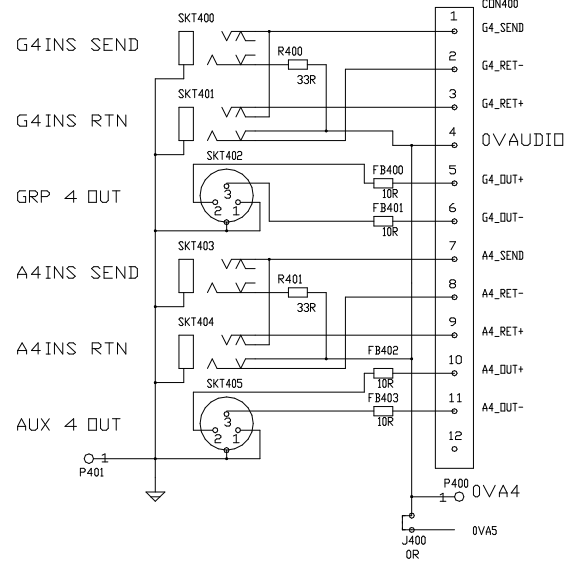

GROUP CHANNEL 5

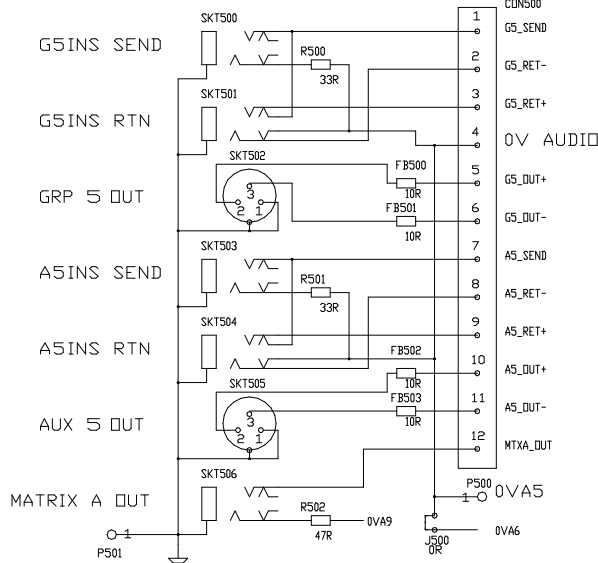

GROUP CHANNEL 6

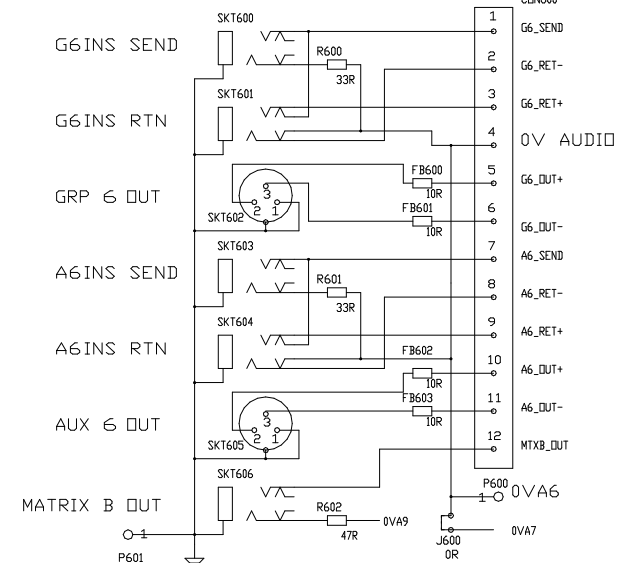

ISS.	REVISION	BY	DATE
A	ORIGIN	AAT	19-07-96
1	EARTHING CHANGES	AAT	17-10-96

NOTES

- RESISTORS MARKED * ARE 1% ALL OTHERS ARE SZ 1/4W UNLESS OTHERWISE MARKED
- ELECTROLYTIC CAPACITORS ARE 2F/VOLTS

UNIT TITLE
L4D SHEET 1 OF 2

DRAWING TITLE
MASTER CONNECTOR PCB
PCB TYPE AG2627

MANUFACTURED IN ENGLAND BY
ALLEN & HEATH

DRAWING No. C2627 ISSUE 1

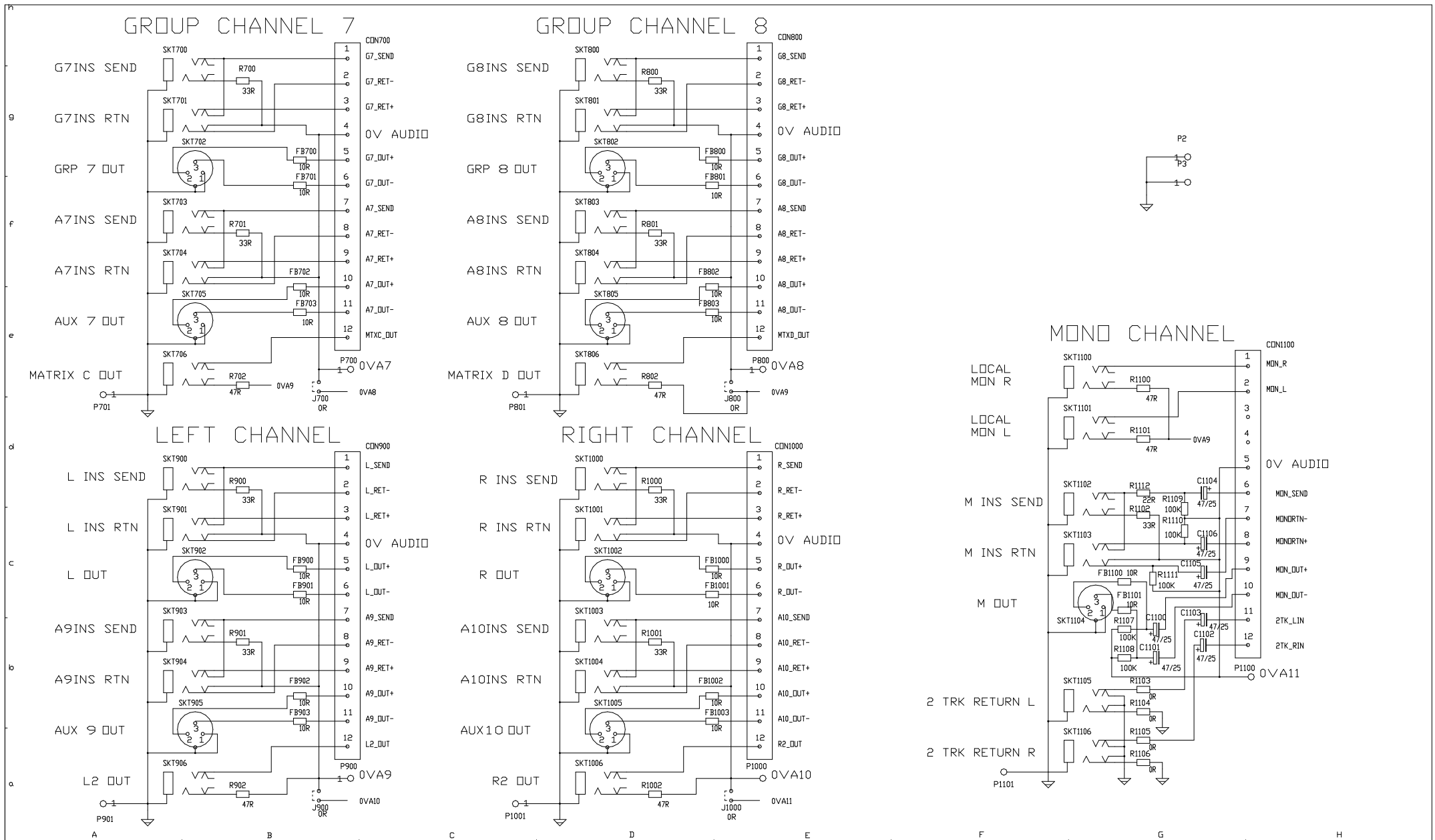

ISS.	REVISION	BY	DATE	NOTES	UNIT TITLE	MANUFACTURED IN ENGLAND BY
A	ORIGIN	AAT19-07-96		1. RESISTORS MARKED * ARE 1% ALL OTHERS ARE SZ 1/4W UNLESS OTHERWISE MARKED 2. ELECTROLYTIC CAPACITORS ARE 16V/50µF	L4D SHEET OF 2	ALLEN & HEATH
1	EARTHING CHANGES	AAT17-10-96			DRAWING TITLE	DRAWING No. C2627 ISSUE 1
					MASTER CONNECTOR PCB	
					PCB TYPE AG2627	

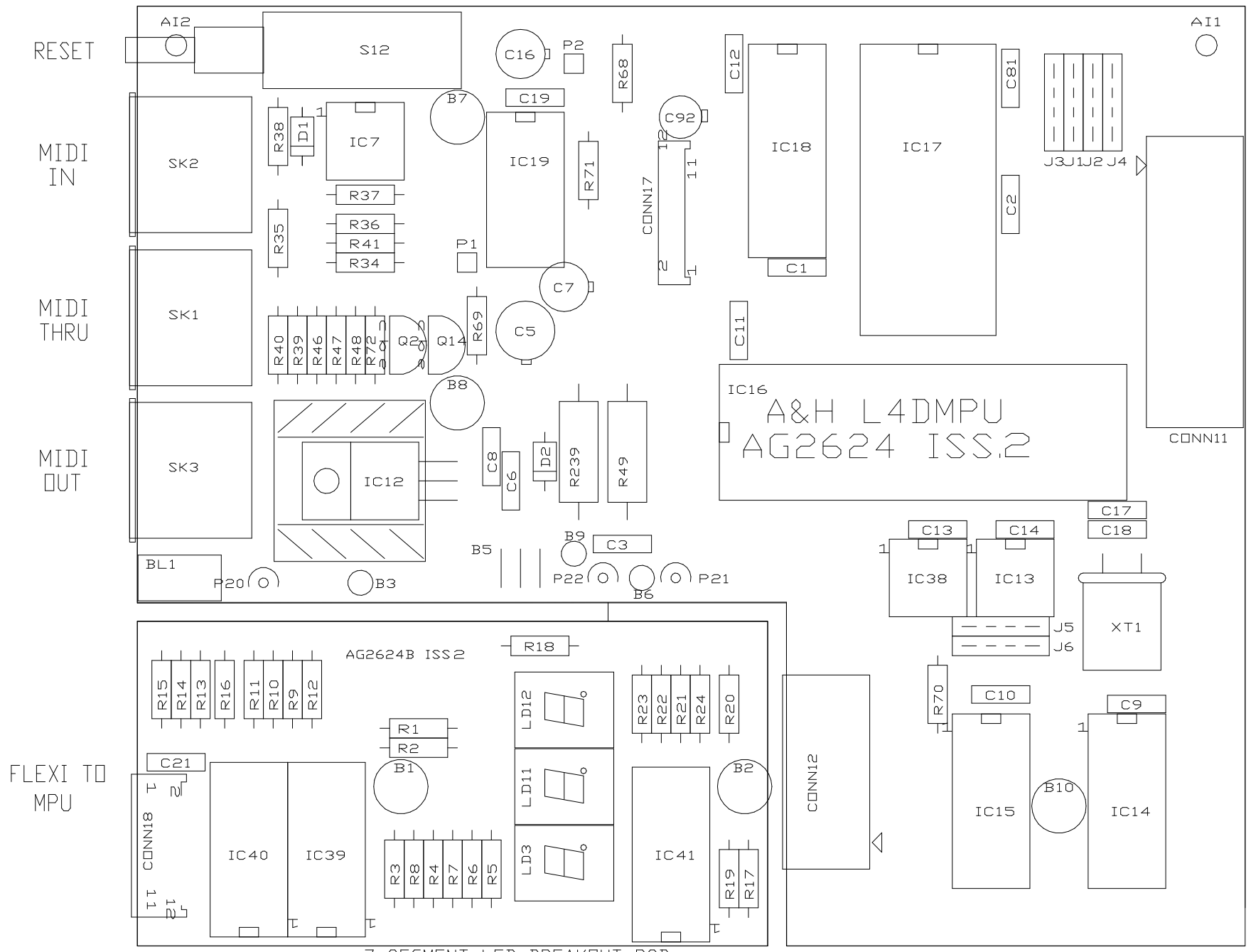

IDC TO MASTER AND SLAVE

IDC TO RH ICB's

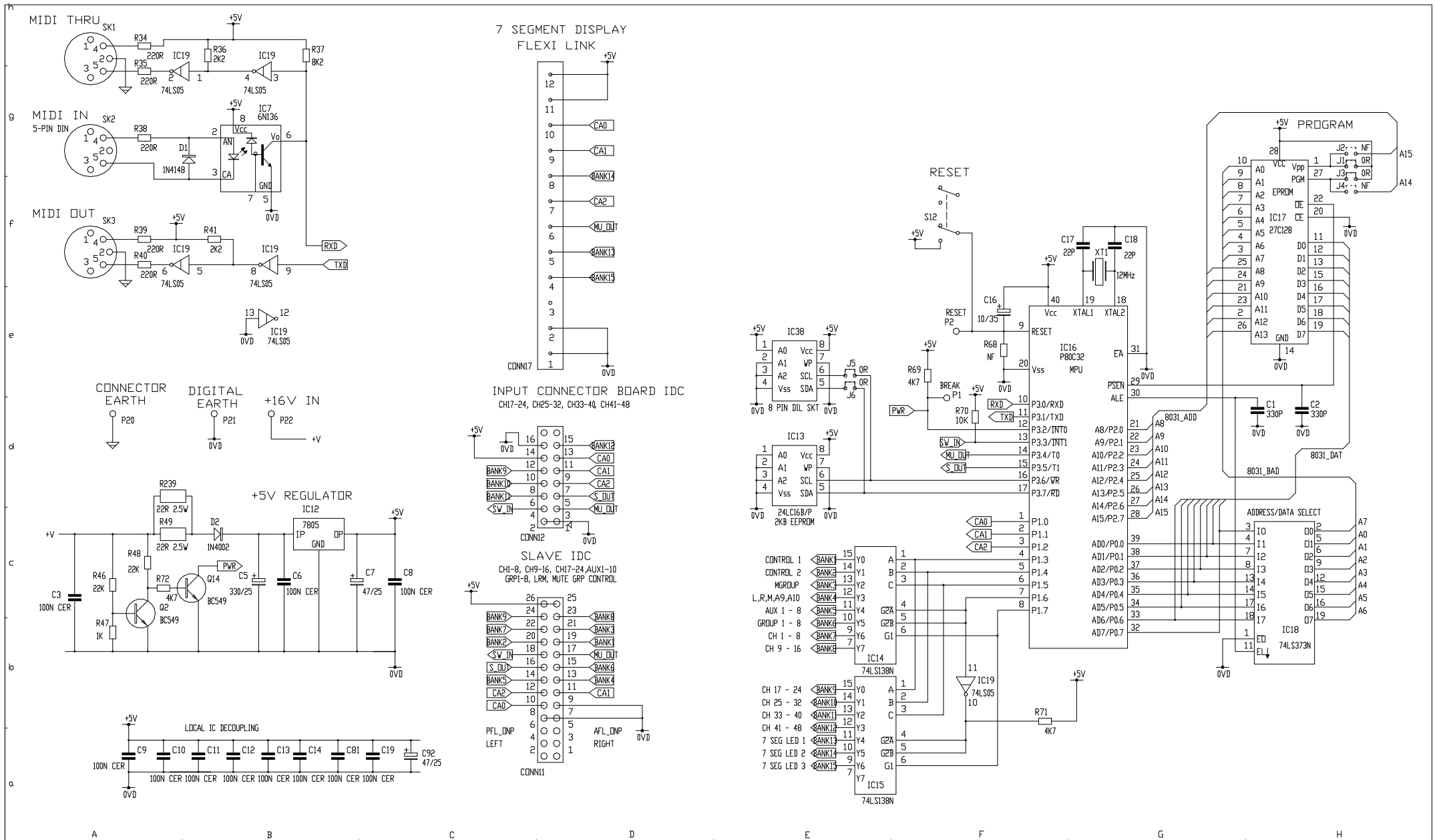

ISS.	REVISION	BY DATE	NOTES	UNIT TITLE	MANUFACTURED IN ENGLAND BY
A	ORIGIN	DLP 13/8/96	1. RESISTORS MARKED * ARE 1% ALL OTHERS ARE 5% 1/4W UNLESS OTHERWISE MARKED	L4D PAGE 1 OF 2	ALLEN & HEATH
B	R1-24 WERE 470R C16 WAS 1/50 IC14,15,16,18 VALUE CHANGED	DRP 9-9-96	2. ELECTROLYTIC CAPACITORS ARE 1%V/DLTS	DRAWING TITLE	DRAWING No.
1	PRODUCTION	AAT25-09-96		MPU CIRCUIT DIAGRAM PCB TYPE AG2624	ISSUE 1 A2

7 SEGMENT LED BOARD AG2624B

(BREAK OUT FROM MPU)

FLEXI FROM MPU BOARD

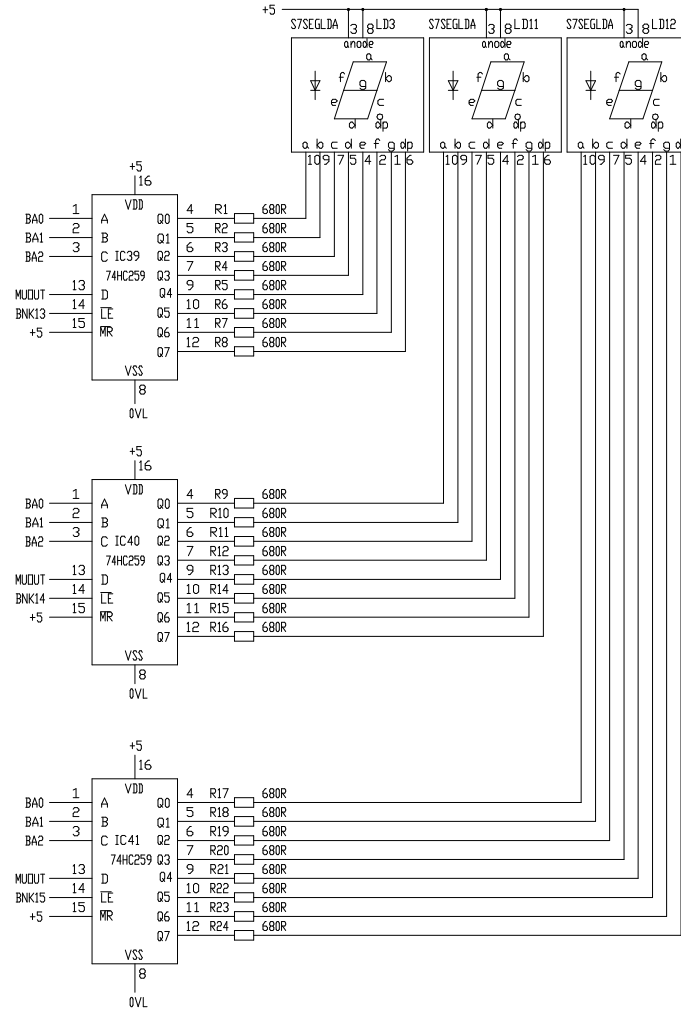
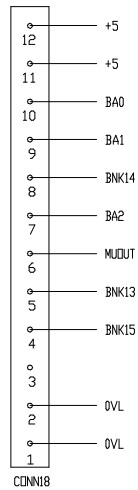

ISS.	REVISION	BY DATE	NOTES	UNIT TITLE	PAGE OF 2	MANUFACTURED IN ENGLAND BY	RG273
A	ORIGIN	DLP 13/8/96	1. RESISTORS MARKED * ARE 1% ALL OTHERS ARE 5% 1/4W UNLESS OTHERWISE MARKED	L4D		ALLEN & HEATH	
B	R1-24 WERE 470R C16 WAS 1/50 IC14,15,16,18 VALUE CHANGED	DRP 9-9-96	2. ELECTROLYTIC CAPACITORS ARE 10% VOLTAGE	MPU CIRCUIT DIAGRAM		DRAWING No.	ISSUE
1	PRODUCTION	AAT25-09-96		PCB TYPE AG2624		C2624	1 A2

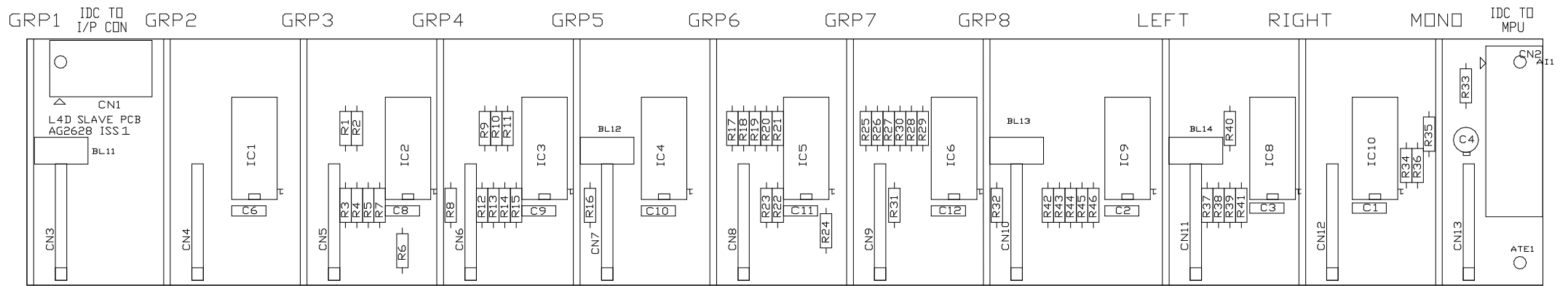

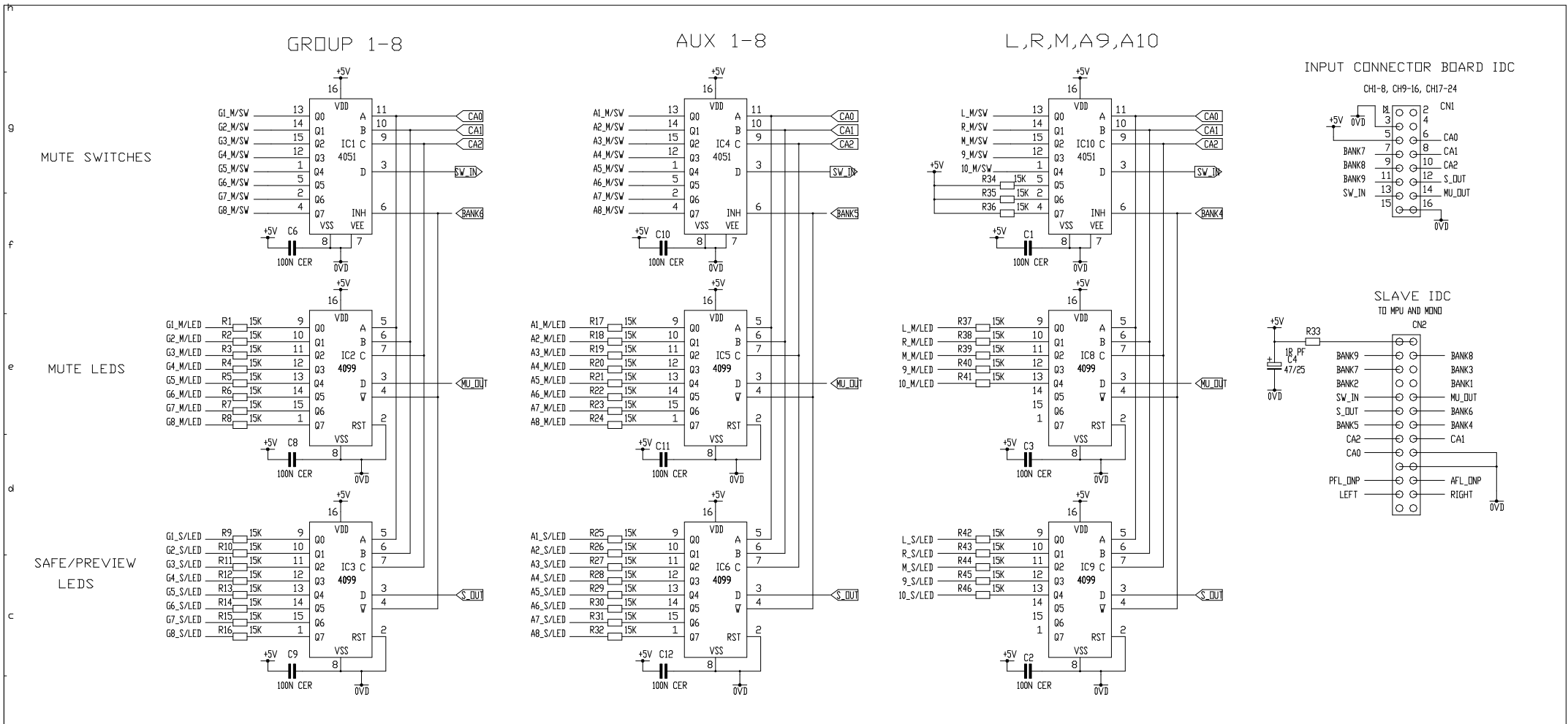

	A	B	C	D	E	F	G	H														
	GROUP 1 PCB	GROUP 2 PCB	GROUP 3 PCB	GROUP 4 PCB	GROUP 5 PCB	GROUP 6 PCB	GROUP 7 PCB	GROUP 8 PCB	LEFT PCB	RIGHT PCB	MOND PCB											
CN3	1	CN4	1	CN5	1	CN6	1	CN7	1	CN8	1	CN9	1	CN10	1	CN11	1	CN12	1	CN13	1	
	G1_M/LED	G2_M/LED	G3_M/LED	G4_M/LED	G5_M/LED	G6_M/LED	G7_M/LED	G8_M/LED	L_S/LED	R_S/LED	PFL_DNP	G1_M/LED	G2_M/LED	G3_M/LED	G4_M/LED	G5_M/LED	G6_M/LED	G7_M/LED	G8_M/LED	L_M/LED	R_M/LED	AFL_DNP
	G1_M/SW	G2_M/SW	G3_M/SW	G4_M/SW	G5_M/SW	G6_M/SW	G7_M/SW	G8_M/SW	L_M/SW	R_M/SW		A1_M/LED	A2_M/LED	A3_M/LED	A4_M/LED	A5_M/LED	A6_M/LED	A7_M/LED	A8_M/LED	9_S/LED	10_S/LED	M_S/LED
	A1_M/LED	A2_M/LED	A3_M/LED	A4_M/LED	A5_M/LED	A6_M/LED	A7_M/LED	A8_M/LED	9_S/LED	10_S/LED		M_S/LED	M_M/LED	M_M/LED	M_M/LED	M_M/LED	M_M/LED	M_M/LED	M_M/LED	9_M/LED	10_M/LED	M_M/LED
	A1_M/SW	A2_M/SW	A3_M/SW	A4_M/SW	A5_M/SW	A6_M/SW	A7_M/SW	A8_M/SW	9_M/SW	10_M/SW												

ISS.	REVISION	BY DATE	NOTES	UNIT TITLE	MANUFACTURED IN ENGLAND BY
A	ORIGIN PRODUCTION	DLP 30/7/96 AAT 25/9/96	1. RESISTORS MARKED * ARE 1% ALL OTHERS ARE 5% 1/4W UNLESS OTHERWISE MARKED 2. ELECTROLYTIC CAPACITORS ARE 16V/100µF	L4D SLAVE CARD	ALLEN & HEATH
1					DRAWING No. C2628 ISSUE 1
				PCB TYPE AG2628	A2

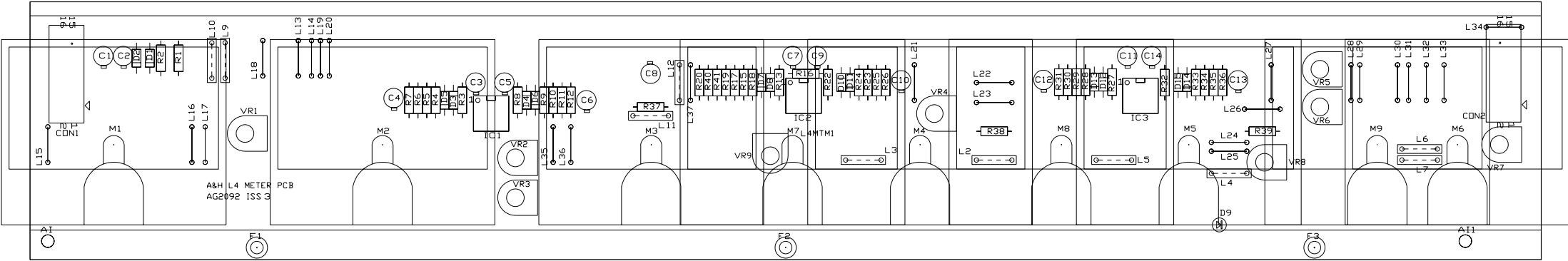

INPUT = -2dBu
FROM GL4 CONSOLE

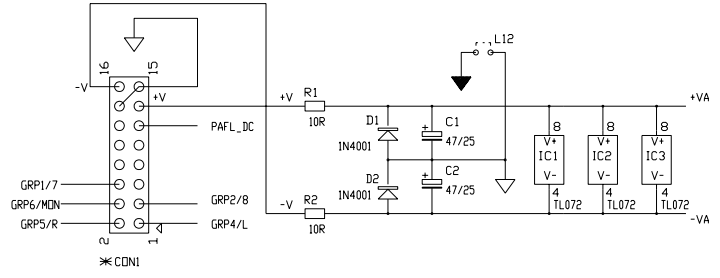
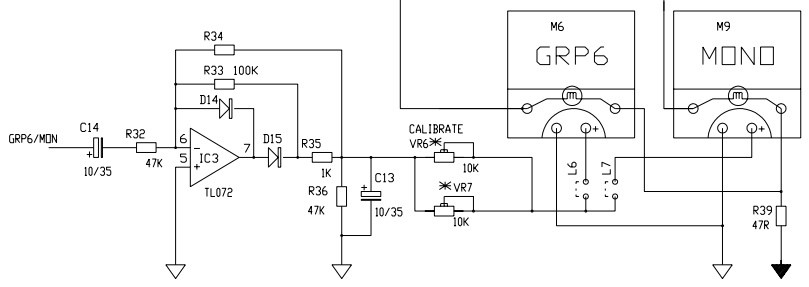
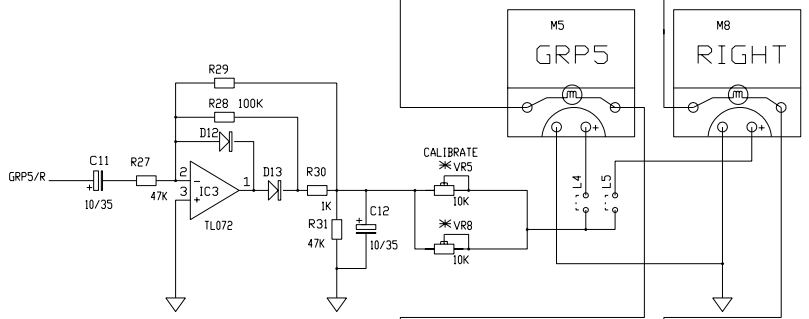
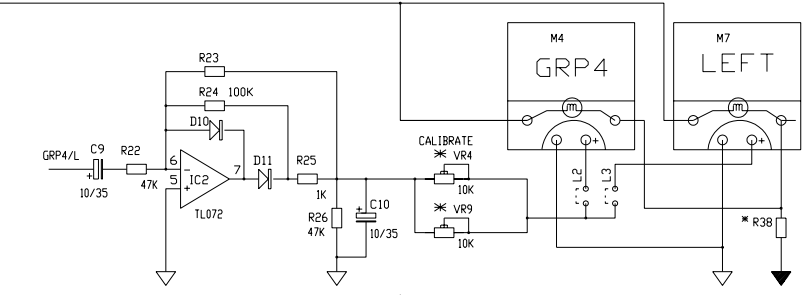
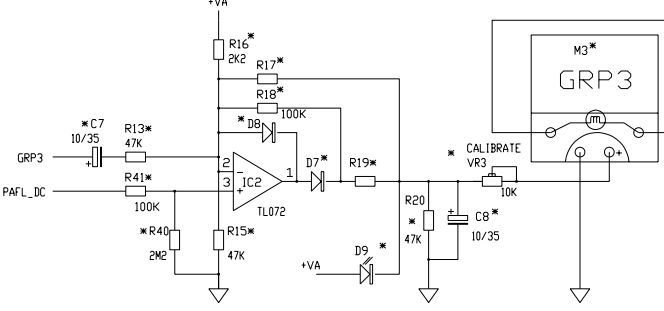
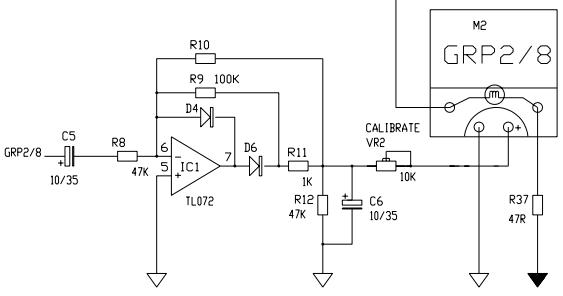
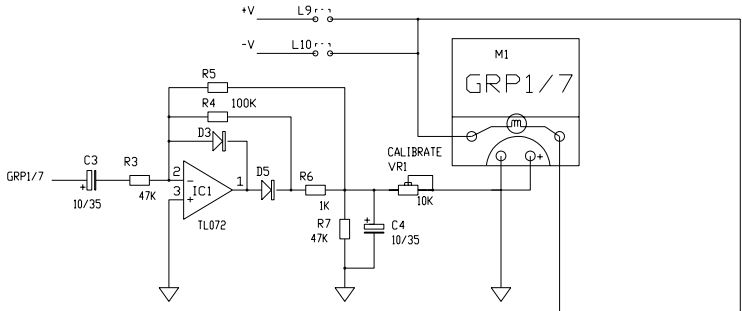

*** PCB CONFIGURATION**

R/H PCB
 FITTED L3,5,7,9,11, R15,16,19,41, D9, VR7,8,
 NOT FITTED L2,4,6,10, C7,8, R13,17,18,20,40,
 D7,8, VR3,5,6, M3,4,5,6, CON1
 VALUES R38=180R, R19=8K2
 L/H PCB
 FITTED VR9
 NOT FITTED L3,5,7,9,11, R15,16,41, D9, VR4,
 M7,8,9, CON2
 VALUES R38=47R, R19=1K

METER CALIBRATION

SET VR1-9 FOR METER READING
 0VU FOR INPUT LEVEL OF -2dBu
 i.e. CONSOLE XLR OUTPUT = +4dBu

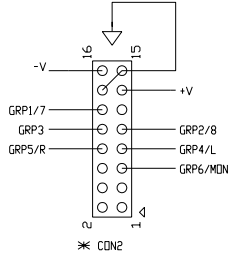

ISS.	REVISION	BY DATE	NOTES	UNIT TITLE	GL4	MANUFACTURED IN ENGLAND BY
A	ORIGIN PRODUCTION	ARJ1-8-94 DRP16-9-94	1. ALL RESISTORS ARE 5% 1/4W UNLESS OTHERWISE MARKED 2. ELECTROLYTIC CAPACITORS ARE 2F/VOLTS 3. ALL DIODES 1N4148 UNLESS OTHERWISE MARKED	DRAWING TITLE	CIRCUIT DIAGRAM METER PCB FOR PCB AG2092	ALLEN & HEATH
						DRAWING No. C2092 ISSUE 1 A2

A&H AG4535 ISS 1 GL SERIES METERS

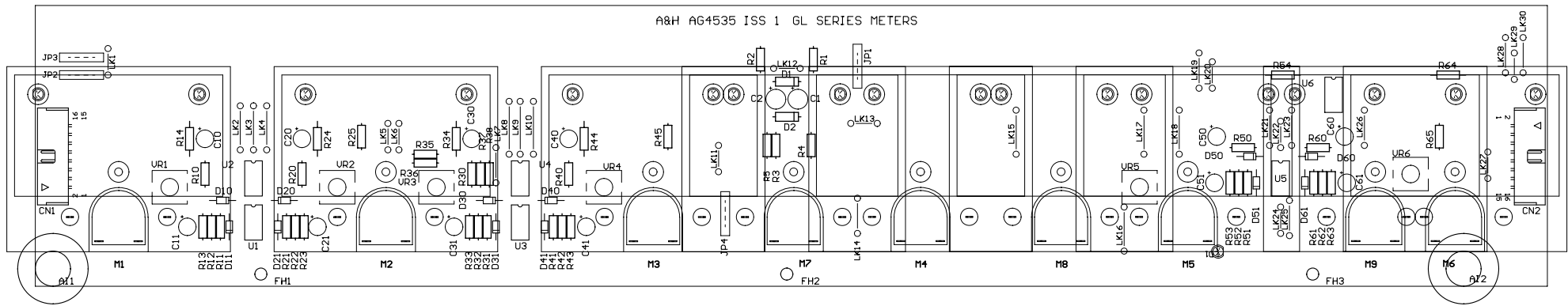

ALLEN & HEATH
 Kernick Industrial Estate,
 Penryn, Cornwall,
 England, TR10 9LU
 Tel: +44 (0)8707 556250
 Fax: +44 (0)8707 556251

TOP OVERLAY .GTO

FILE: AG4535_1.PCB PRINTED: 11:45:10 1-Oct-2001

TITLE: GL SERIES METERS PCB

DRG No: AG4535 ISSUE: 1

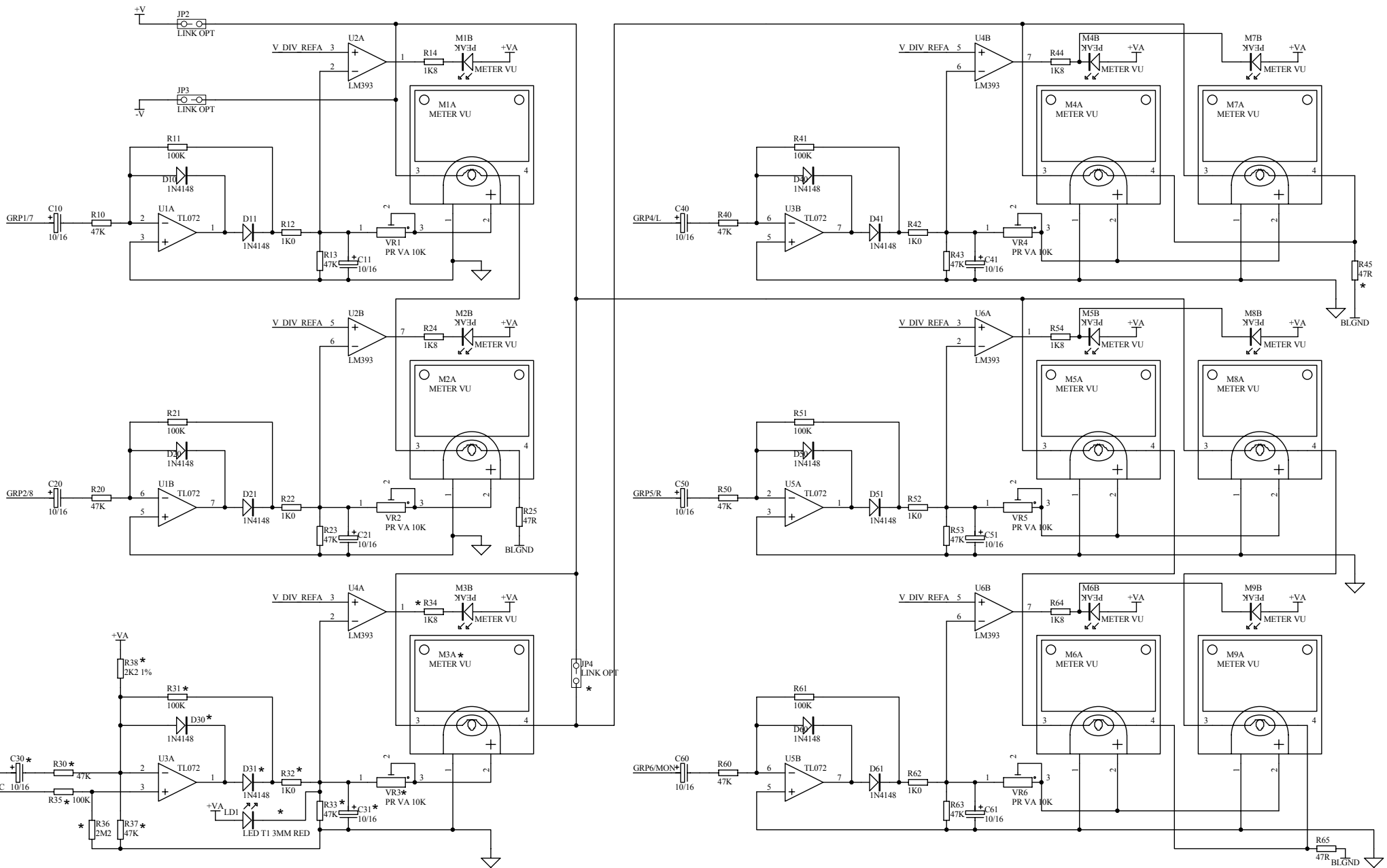

ISSUE	BY	DATE
A 1	AAT AAT	19-07-01 14-08-01

FILE: C4535_1P2.Sch
 PRINTED: 13:53:33 3-Oct-2001

TITLE: GL SERIES METERS
 PAGE: METERS AND DRIVERS
 DRG No: C4535
 ISSUE: 1
 SHEET: 2 OF 3
 A3

ALLEN&HEATH
 Kernick Industrial Estate,
 Penryn, Cornwall,
 England. TR10 9LU
 Tel: +44 (0)8707 556250
 Fax: +44 (0)8707 556251

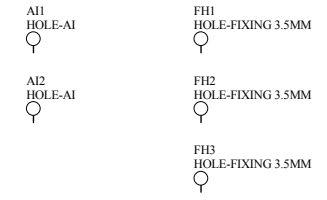
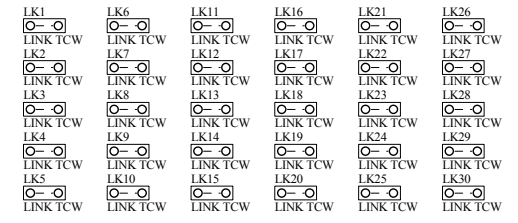
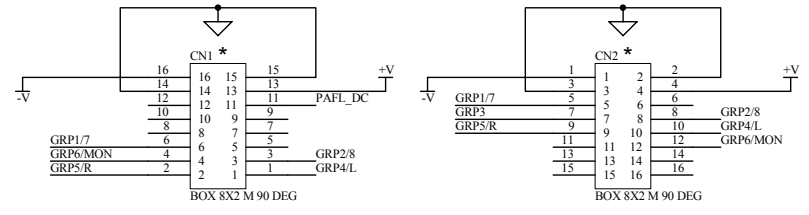
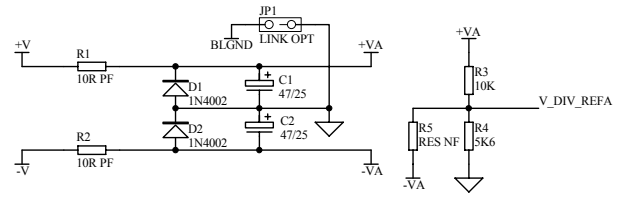
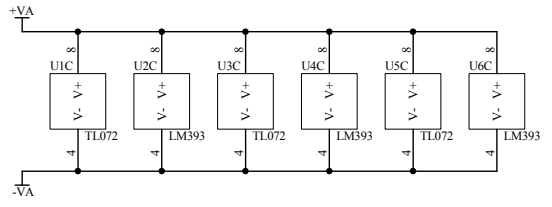

ISSUE	BY	DATE
A 1	AAT AAT	19-07-01 14-08-01

FILE: C4535_1P3.Sch	PRINTED: 14:10:13 3-Oct-2001
---------------------	------------------------------

TITLE: GL SERIES METERS	PAGE: POWER AND CONNECTORS
DRG No: C4535	ISSUE: 1
SHEET: 3 OF 3	A3

ALLEN&HEATH
 Kernick Industrial Estate,
 Penryn, Cornwall,
 England. TR10 9LU
 Tel: +44 (0)8707 556250
 Fax: +44 (0)8707 556251

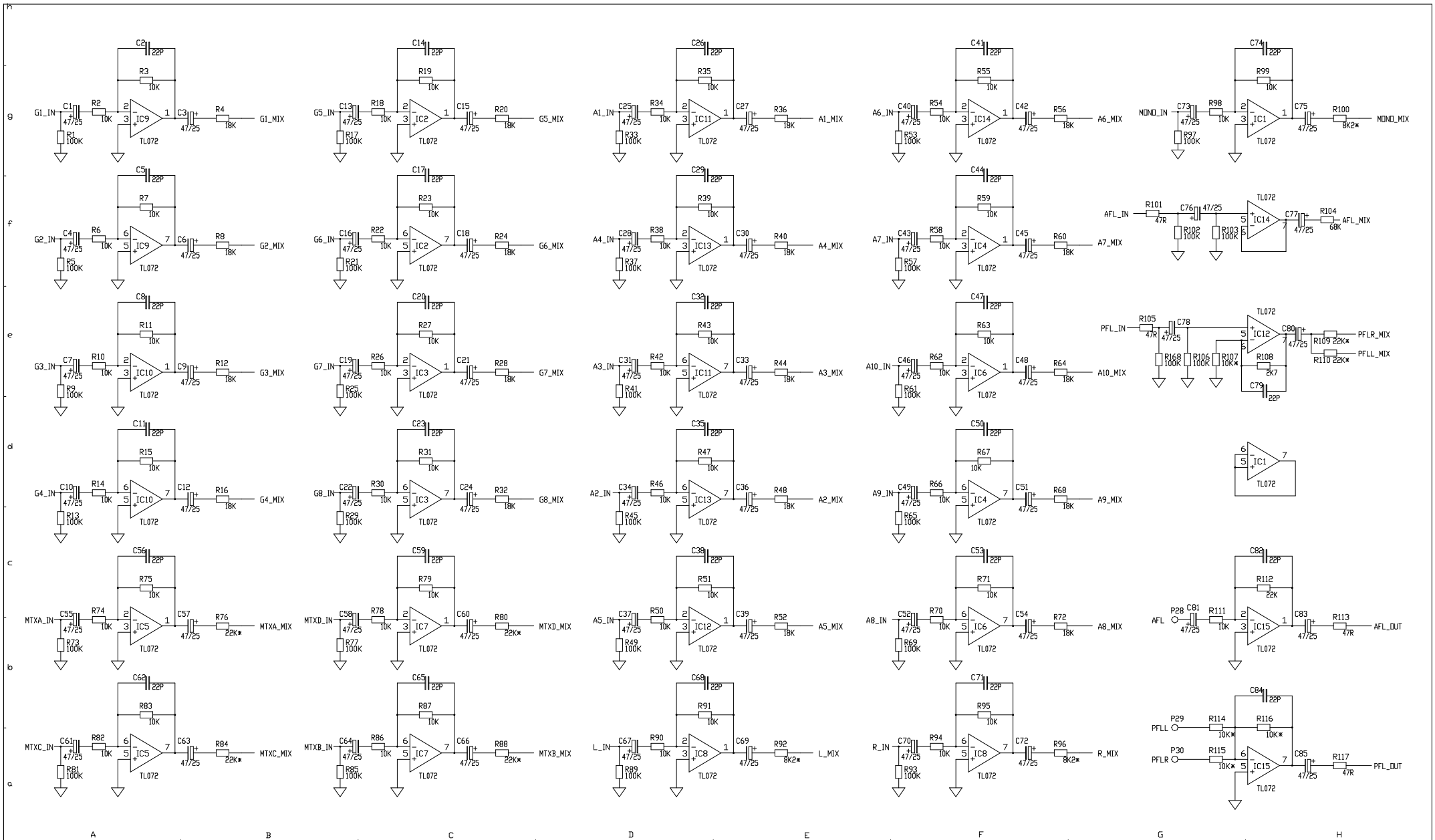

ISS.	REVISION	BY DATE	NOTES	UNIT TITLE	MANUFACTURED IN ENGLAND BY
A 1	ORIGIN PRODUCTION	AAT16-09-96 AAT13-11-96	1. RESISTORS MARKED * ARE 1% ALL OTHERS ARE 5% 1/4W UNLESS OTHERWISE MARKED 2. ELECTROLYTIC CAPACITORS ARE 10V/VOLTS	L4D SYS_LINK PCB TYPE AG2792	ALLEN & HEATH
				DRAWING TITLE	DRAWING No. C2792 ISSUE 1
					A2

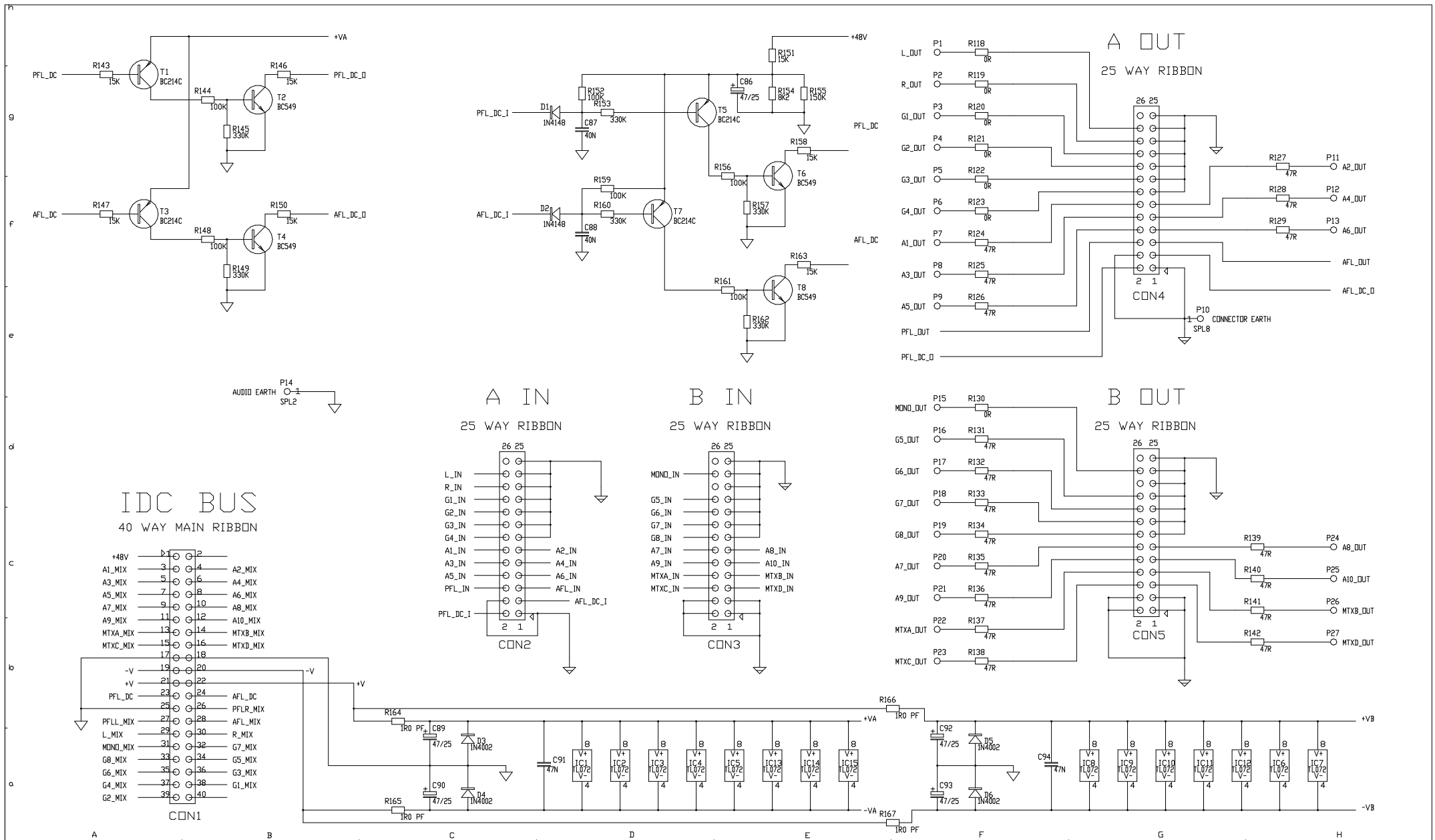

ISS.	REVISION	BY DATE	NOTES	UNIT TITLE	MANUFACTURED IN ENGLAND BY
A	1	ORIGIN PRODUCTION	AAT16-09-96 AAT13-11-96	L4D SYS_LINK PCB TYPE AG2792	ALLEN & HEATH
1. RESISTORS MARKED * ARE 1% ALL OTHERS ARE SZ 1/4W UNLESS OTHERWISE MARKED 2. ELECTROLYTIC CAPACITORS ARE 10V/VOLTS				DRAWING No. C2792 ISSUE 1	
				A2	

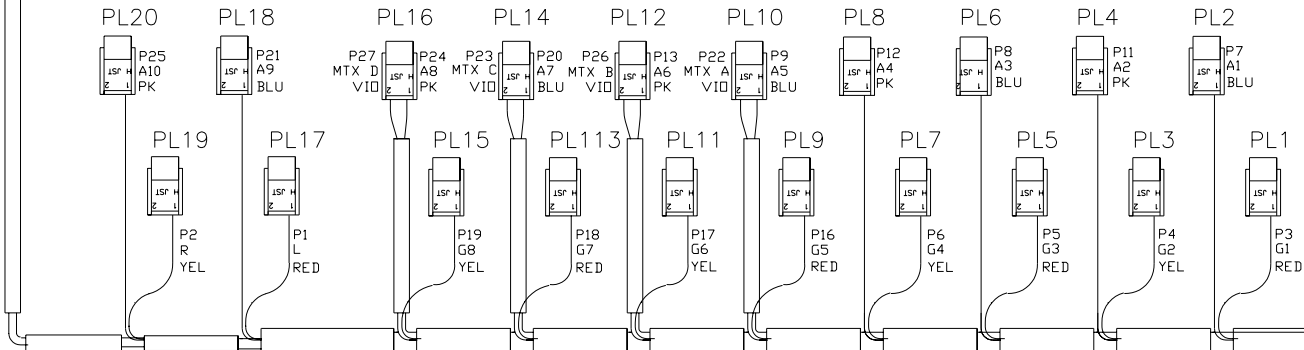
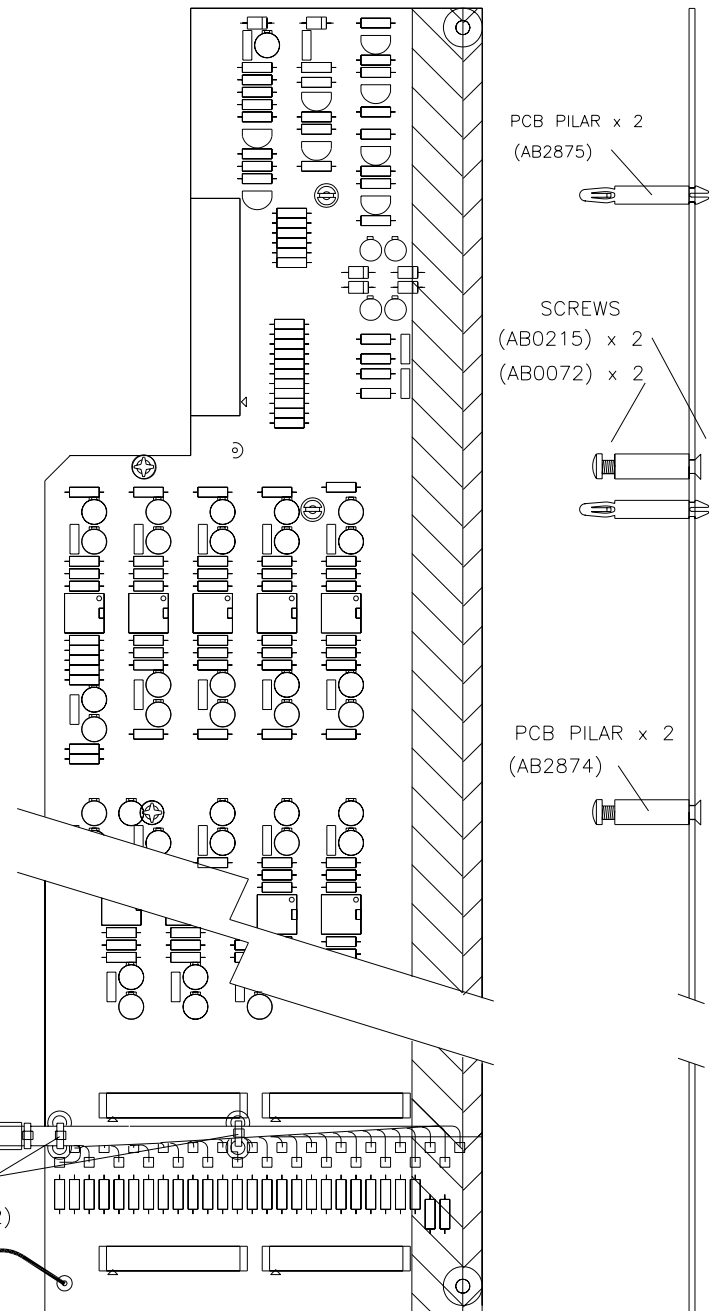
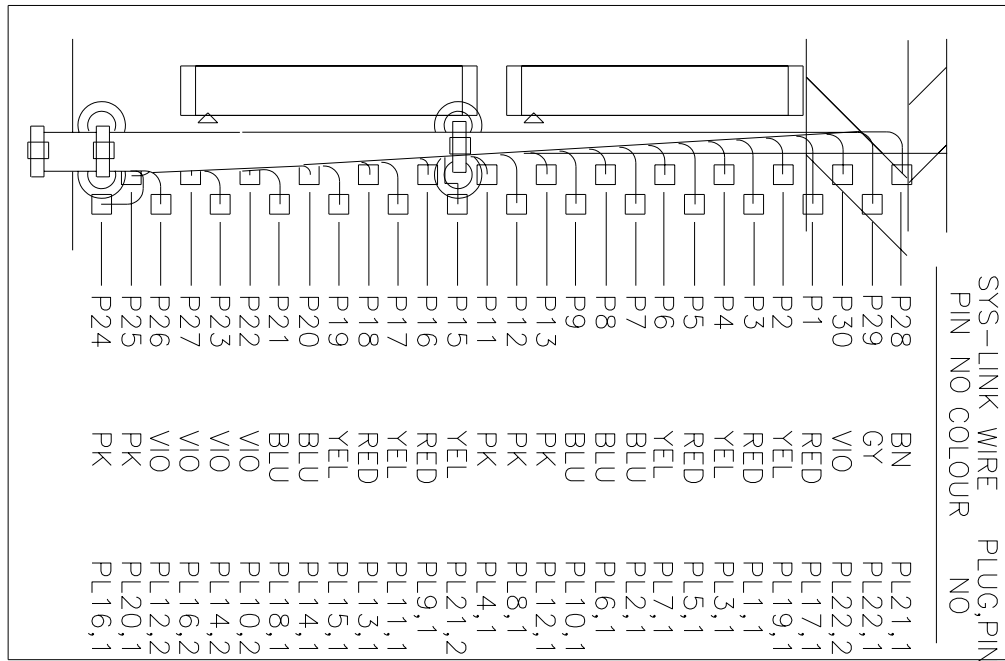
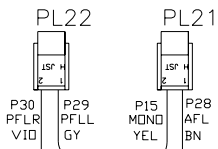

SCREW SELF TAP (AB2084)
 CRINKLE WASHER (AB0244)
 CABLE TIES (AK0151)
 SOLDER TAG (AK0002)

WIRE 32/02 GREEN (AH2274) x 80 mm

ISSUE	REVISION	BY	DATE	STANDARD NOTES
A	ORIGIN	AAT	22-10-96	ALL DIMENSIONS IN mm
1	PRODUCTION	AAT	13-11-96	DO NOT SCALE DRAWING
				THIRD ANGLE PROJECTION

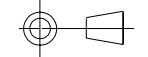

DRAWING TITLE L4D SYS-LINK PCB/WFM ASSY
 STOCK CODE 002-211

ALLEN & HEATH
 ALLEN & HEATH
 KERNICK INDUSTRIAL ESTATE,
 PENRYN, CORNWALL TR10 9LU.
 TEL. 01326 372070
 FAX. 01326 377097

DRAWING No M002-211 Sheet 1 OF 2 ISSUE 1 A2

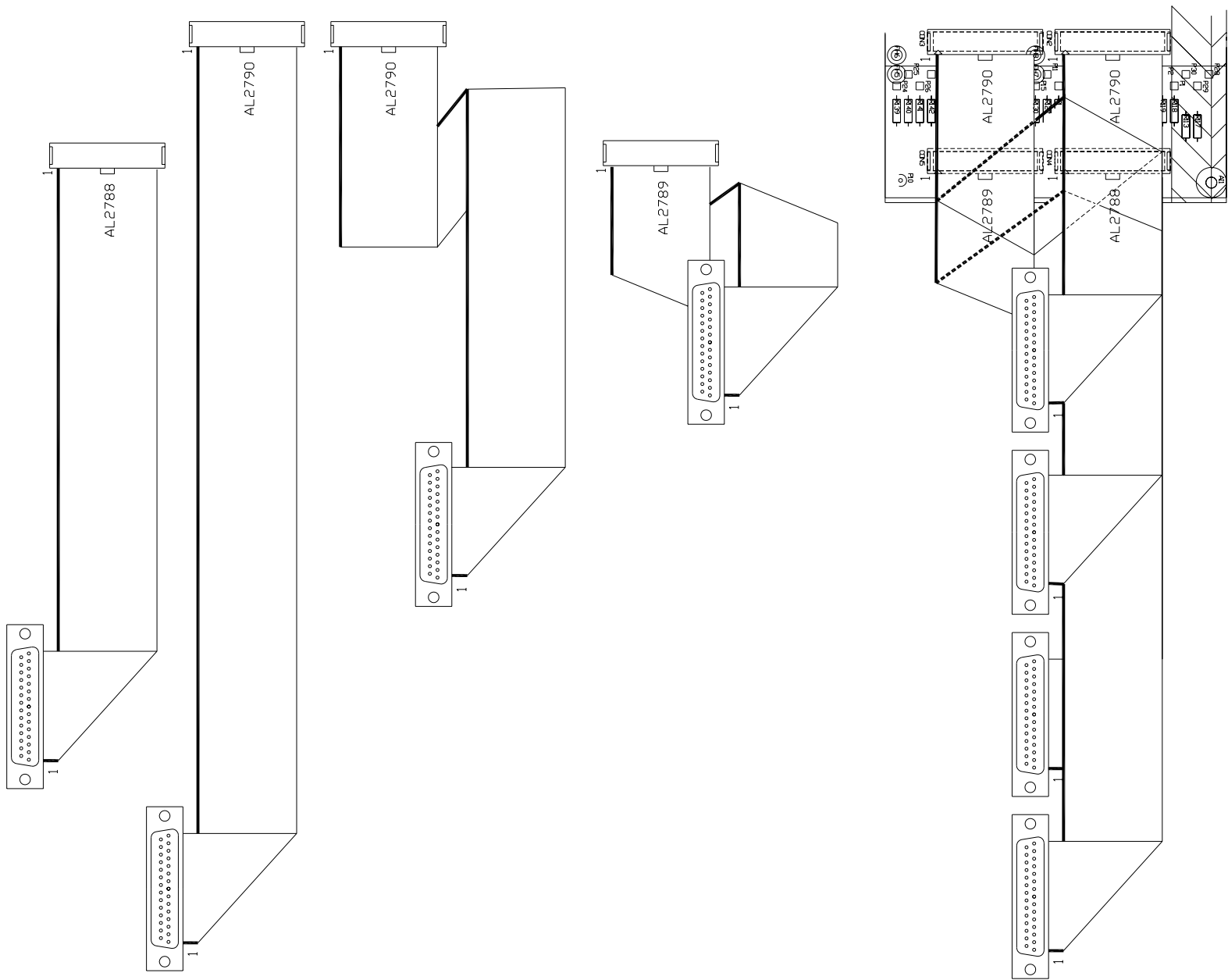

ISSUE	REVISION	BY	DATE
1	ORIGIN	AAT	15-11-96

STANDARD NOTES
 ALL DIMENSIONS IN mm
 DO NOT SCALE DRAWING
 REMOVE ALL BURRS & SHARP EDGES
 THIRD ANGLE PROJECTION

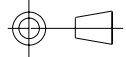

TOLERANCES	
GENERAL	+/- 0.25
HOLE CENTERS	+/- 0.15
HOLE SIZES	+/- 0.10
SCALE APPROX:	1 : 1

MATERIAL

FINISH

DRAWING TITLE
 L4D SYS-LINK
 PCB/IDC WFM ASSY

STOCK CODE
 M002-211

	ALLEN & HEATH LTD KERNICK INDUSTRIAL ESTATE, PENRYN, CORNWALL TR10 9LU. TEL. 0326 372070 FAX. 0326 377097
	DRAWING No M002-211 Sheet 2 OF 2 ISSUE 1 A2

SECTION D

D

POWER SUPPLY

CAUTION !

TO AVOID DAMAGE TO INTERNAL COMPONENTS BY MISHANDLING AND/OR MISCONNECTION, ONLY TECHNICALLY COMPETENT PERSONNEL SHOULD ATTEMPT SERVICE WORK ON THIS UNIT.

TECHNICAL DESCRIPTION

The ALLEN & HEATH *RPS11* power supply is purpose designed for the *GL4000* range of sound reinforcement consoles.

CONSTRUCTION

All metal chassis for rack mounting in a 19" by 3U space. The unit comprises of a 16swg steel front panel with integral top cover and a separate 16swg steel chassis base on which all the main components are mounted.

INSTALLATION

The *RPS11* is designed to occupy 3U (5.25 inches) of rack space. An important consideration when rack mounting the unit is the need for natural convection of air flow over the whole unit. Good ventilation below the unit, in the floor or back of the rack, will ensure a path for continuous air flow. Other equipment in the rack which is known not to produce a significant amount of heat should be mounted below the unit. Equipment which also relies on good air flow within the rack (i.e. most power amplifiers and other power supplies) should be given due consideration and some space should be provided between such units and between the *RPS11* unit. Forced convection, by means of a fan-tray, may be desirable in this situation.

The *RPS11* can be operated as a free standing unit without requiring any special cooling arrangement, but should not be covered in any way. Always stand the unit on a firm flat surface well away from any soft furnishings.

THE POWER SUPPLY AND CONSOLE EARTHING

The *RPS11* is a linear power supply which, like other linear supplies, produces DC voltages by rectifying, smoothing and regulating AC voltages from the secondary windings of a mains transformer. This unit connects to the local AC mains supply and provides the regulated DC operating voltages required by the *GL4000* console. The *RPS11* DC output lead is terminated at both ends with an inline 10 pin round connector. A male connector at one end and a female connector which plugs into the console DC INPUT at the other. Near to the console DC INPUT connector is an earth terminal labelled CHASSIS GROUND. This terminal is connected to mains earth via the DC power cable of the *RPS11*.

THE CHASSIS METALWORK IS ALWAYS CONNECTED TO MAINS EARTH VIA THE EARTH WIRE IN THE MAINS PLUG. DO NOT REMOVE THE EARTH WIRE CONNECTION IN THE MAINS PLUG !

SPECIFICATION

AC MAINS INPUT VOLTAGE RANGES:	100V - 120V, 220V - 240V @ 47Hz to 63Hz single phase
POWER CONSUMPTION:	320VA 300W
DC OUTPUTS:	+16V @ 5A, -16V @ 5A, +48V @ 200mA
OUTPUT NOISE & RIPPLE:	< 1mV (peak to peak)

DC Output Socket Pin Connections

Pin 1	= +16 Volts
Pin 3	= -16 Volts
Pin 4	= CHASSIS 0V
Pin 5	= AUDIO 0V
Pin 10	= +48 Volts

Pins 2, 6, 7, 8, 9, = not connected

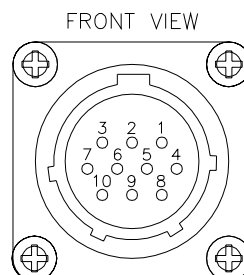

Overall Dimensions

Front Panel
19 inch 3U (482mm x 133mm)

Weight : 9.5Kg (21 pounds)

Chassis (Maximum External)
Height: 135mm including feet (5.31 inches)
Width: 419mm (16.50 inches)
Depth: 235mm (9.25 inches)

FUSE RATING & REPLACEMENT

The AC mains fuse is located on the rear of the *RPS11* unit next to the AC mains connector. In the event of a mains surge or under-rated fuse value, the mains input fuse will rupture. Switch the unit mains “on/off” switch to the off position and remove the mains lead plug from the “AC MAINS IN” socket on the rear of the unit. Lever out the fuseholder square top with a suitable tool and pull the fuse carrier assembly clear of the body. Replace the fuse and push the fuse carrier back into place. Check that the AC mains input voltage setting is correct for the mains supply in your area before switching the unit on again.

Check the correct fuse is fitted for the selected mains input voltage.

Voltage Setting	Fuse
220/230 VAC	T 3.15A / 250V 20mm
100/120 VAC	T 5.0A / 250V 20mm

MAINS VOLTAGE SETTING

The *RPS11* is capable of operating over a wide range of AC mains input voltages by means of a comprehensive set of selectable voltage settings. It is important to check that the *RPS11* has the correct voltage setting as marked on the rear panel of the power supply. Confirm that the voltage setting matches the local AC mains supply in your area.

Check the arrow indicates the correct AC mains voltage setting for your local AC mains supply

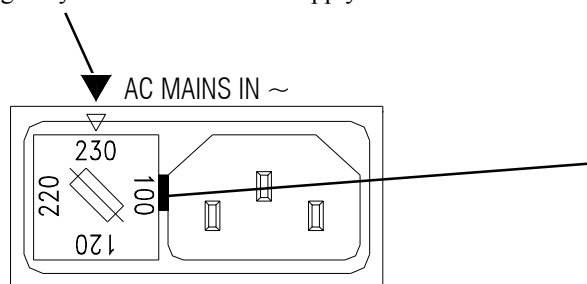

FUSE TYPE	AC SUPPLY	47-63Hz
T 3.15A 20mm	220 - 240V~	320VA MAX
T 5.0A 20mm	100 - 120V~	300W MAX

To alter the AC mains input voltage setting, lever out the fuseholder square top with a suitable tool. Pull the fuse carrier assembly clear of the body, rotate the fuse carrier body until the required voltage aligns with the arrow and push the fuse carrier back into place.

Check the correct fuse is fitted for the selected mains input voltage.

Set:

100 V marking for ac mains input 100-115 V ac

120 V marking for ac mains input 115-125 V ac

220 V marking for ac mains input 210-230 V ac

230 V marking for ac mains input 230-264 V ac

DO NOT ATTEMPT TO USE THE POWER SUPPLY IF IT IS SET TO A DIFFERENT AC MAINS INPUT VOLTAGE TO THE LOCAL AC MAINS SUPPLY IN YOUR AREA