

ALLEN & HEATH



WARNING – HIGH VOLTAGES

Power Supply Unit (PSU) work should only be carried out by qualified personnel.

We recommend that you use an approved Allen & Heath service centre for all power supply work.

Please contact your local Allen & Heath distributor for more details.

<http://www.allen-heath.com/>



SABER

*Modular Sound Mixing
Consoles*

building on success

The latest Saber builds on the unique success of the original Saber series launched in 1988.

Although the highly successful visual design has been retained there are many advances and added facilities beneath Saber's quality finish.

Saber is for 16 and 24 track recording studios and for live sound, both installed and touring. The new matrix module further enhances Sabers claim as a leading PA console, while significant improvements in sound transparency further enhance its role in the digital multitrack studio.

The fully modular range is designed to allow maximum flexibility now and in the future.

Every Saber is complete with a user friendly MIDI based mute automation system.

SABER FEATURES

- MIDI mute processor providing independent control of individual mutes as well as "scene change" memories.
- Four frame sizes and choice of VU or Bargraph meterbridge on recording consoles.

- Three signal sources per fader: mic/ tape/ line for channels, group/tape/line for monitors. Up to 56 inputs and 4 returns for mixdown.
- Patchbay option for large frame recording console.
- Unique checking system providing PFL and Solo In Place as set by master status switch.
- Mic, line, tape, inputs and mono, stereo and group outputs electronically balanced.
- Console stand included on recording formats, optional for PA.
- Ergonomic control layout with EQ close to hand.
- Four band equalizer with two swept, overlapping mid frequency controls plus switchable shelf high and low frequency controls.
- Low cut filter selectable independently of the equalizer.
- Industry standard high quality amplifiers and 100mm Alps faders.
- Direct interface to two separate intercom systems on PA monitor module.
- Provision for 12V gooseneck lamps on PA formats.
- 24 track monitoring now available by specifying four of the recently introduced M335 modules plus 24 track metering. Outputs 1-8 are repeated

on XLRs for connection to tracks 17-24.

- Matrix output module M326 for multi speaker distributed sound reinforcement now available on Saber PA consoles.
- Extra large frame version for twenty four track studio applications now includes a twenty four track patchbay and gives 36:16:24 format. (Available Spring 1990)
- Extra large frame PA version gives 48:8:8 format including matrix output facilities (Available Spring 1990).
- MIDI mute processor provides independent control of individual mutes, "scene change" snap shot memory of mutes, and song-position-pointer MIDI sync of mute events. Choice of Control Change or Note on-off operation. Automatic sync to drop-in point using external sequencer memory and song position pointer.
- EQ and fader reverse on multitrack monitors for use as remix return inputs.
- Channel aux send options include pre fader with mute facility for full control of live sound foldbacks.

MUTE PROCESSOR

■ Allen & Heath's latest generation of mute control computers is included as standard on all Saber consoles.

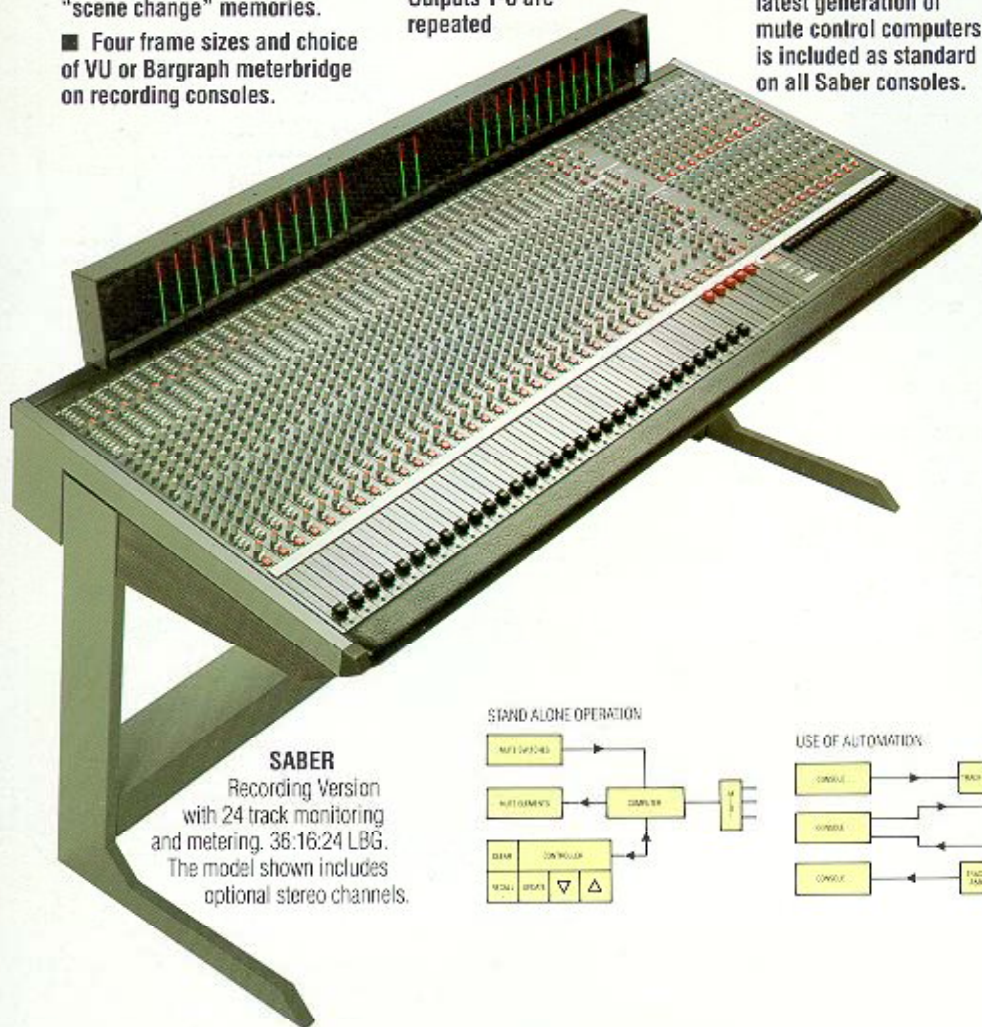

SABER
Recording Version
with 24 track monitoring
and metering. 36:16:24 LBG.
The model shown includes
optional stereo channels.

STAND ALONE OPERATION

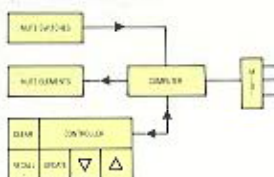

USE OF AUTOMATION

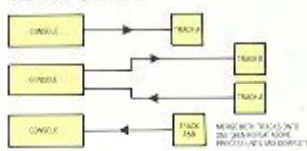

SEQUENCER WITH MIDI

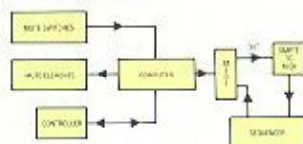

MIDI Specification: MCM v3.1 P/R

Function	Default Channel	Transmitted	Recognized	Remarks
Basic Channel	16	1-16	1-16	
Mode	Default Messages Altered	3 X X	X X X	No Mode Command Transmitted or Received
Note Number	True	0-7FH 0-7FH	0-7FH 0-7FH	Band Width disabled by console format
Velocity	Note ON Note OFF	X X	0-Note off X	40H Transmitted, otherwise ignored except for 0-Note on
Alter Touch	Key's Ch's	X X	X X	
Pitch Bender		X	X	
Control Change		0	0	External auto update. Block ID's. Console Mute abort. 60H-70H 74H & 75H
Prog Change	True #	0 0-1FH	0 0-7FH	Mod 32
System Exclusive		0	0	
System	:Song Pos :Song Sel	X X	0 X	
Common	:Tune	X	X	
System	:Clock Real Time:Commands	X X	0 0	
Aux Messages	:Local ON/OFF :All Notes Off :Active Sense :Reset	X X X X	X X X X	
Notes				Local Mode Front Panel Switchable

Mode 1: OMNI ON, POLY Mode 2: OMNI ON, MONO Mode 3: OMNI OFF, POLY Mode 4: OMNI OFF, MIXED C=Yes X=No

INPUT M310**+48V PHANTOM POWER SWITCH**

For microphone powering

PAD

Microphone input attenuator 20dB actively reduces gain and noise.

TAPE

Balanced tape input selector switch (input paralleled with monitor on groups 1-16)

LINE

Balanced line input selector switch

Ø SWITCH

Phase reverse on all sources

GAIN

For input level adjustment

ASSIGN:Multitrack routing selector bank and L-R routing switch
SHIFT selects outputs 1-8 or 9-16**AUX SENDS:**

Pre/post selector for Aux sends 1 & 2

Aux send level controls 1-6 for setting up various cue and echo/reffect mixes

Internal links are provided for pre-eq, pre fade or post fade sends and pre fader with mute

PA consoles are shipped with the pre-fader source internally preset "pre-fade with mute"
Recording consoles are shipped "pre-fade without mute"**HF EQ**

Corner frequency selector switch 6kHz/12kHz

Cut boost control ± 12 dB with shelving characteristic**HIGH MF EQ**High mid peaking characteristic eq with cut/boost control ± 12 dB and frequency range 1kHz-10kHz**LOW MF EQ**Low mid peaking characteristic eq with cut/boost control ± 12 dB and frequency range 200Hz-2kHz**LF EQ**Cut/boost control ± 12 dB with shelving characteristic
LF corner frequency switch 70Hz/140Hz**EQ ON**

Eq on switch to allow instant comparison

LOW CUT FILTER

To attenuate frequencies below 80Hz at 12dB/oct

PAN CONTROL

Used with routing selector to assign tracks and position in L-R mix

CHECK

PFL or SOLO IN PLACE set by master control (with indicator LED)

MUTEMIDI programmable FET mute with LED cuts all post fade signal sends and pre-fader mute
Aux send option**PEAK**

LED illuminates 3dB before overload. Detects post eq pre-fader signal level

CHANNEL FADER100 mm Alps fader with ± 10 dB boost available**INPUT MODULE M310X**

As M310 with added circuitry to mute the control room monitor output when the fader is opened. The Mute Control connector interfaces with external equipment for control of ON AIR lights and other monitor loudspeakers.

STEREO INPUT M360**INPUT SELECTOR**

Selects stereo input 1 or 2. Input 1 may be ordered with RIAA equalisation, M360X

Ø SWITCH

Allows phase on left signal path to be reversed

STEREO SIGNAL SELECTOR

Operates after the input selector.

Release both switches for normal operation. L selects L input to both channels. R selects R input to both channels. L+R gives mono mix on both channels

GAIN

For input level adjustment

ASSIGN:Multitrack routing selector bank and L-R routing switch
L = odd numbers, R = even numbers**AUX SENDS:**

Pre/post selector for Aux sends 1&2

Level and balance control for mix Aux 1 & 2 for cue. L=1, R=2

Level and balance control for Aux 3 & 4. L=3, R=4

Send level controls for Aux 5 & 6. L+R = 5, L-R = 6

Internal links are provided for pre fade or post fade sends

HF EQ

Corner frequency switch 6kHz/12kHz

Cut/boost control ± 12 dB with shelving characteristic**MF1**Cut/boost control ± 12 dB peaking characteristic at a centre frequency of 2.5kHz**MF2**Cut/boost control ± 12 dB peaking characteristic at a centre frequency of 250Hz**LF EQ**Cut boost control ± 12 dB with shelving characteristic
Corner frequency switch 70/140Hz**EQ ON**

Eq on switch to allow instant comparison

BALANCE CONTROL

Adjusts the relative levels of L and R channel signals from the fader to the assign section

SOLO SAFE

Disconnects channel from solo bus, allowing use as an echo return input.

CHECK

PFL or SOLO IN PLACE set by master control (with indicator LED)

CHANNEL ON

Combined Audio on-off and remote start function. When ON, fader open = start, fader closed = stop. When OFF and fader open, then ON = start, OFF = stop. Used for remote control of programme sources

PEAK

LED illuminates 3dB before overload. Detects post eq pre-fader signal level

CHANNEL FADER100mm Alps stereo fader with ± 10 dB boost available**MONITOR MODULE**

Master output/monitor system; four module widths. Left hand half is identical for Recording and PA versions

AUX MASTER SECTION

Contains master controls for each of Aux 1-6 outputs. All axes identical

LEVEL

Level control for Aux Output

PFL

Prelade listen switch with LED

MUTEOutput mute with LED indicator
Not programmable**RETURNS 1-4**

Are mono line level inputs for external effects or to bring other consoles into the mix. They are not muted by SOLO IN PLACE

RETURN INPUT 1(2)**ASSIGN:**

Multitrack routing selector bank and L/R routing switch

HF CONTROLShelving characteristic with ± 12 dB cut/boost at 10kHz**LF CONTROL**Shelving characteristic with ± 12 dB cut/boost at 100Hz**AUX SENDS:**

Aux send level controls 1 & 2 for cue mix

LEVEL CONTROL

Return signal level to assigned outputs

PAN CONTROL

Used with routing selector to assign tracks and position in L-R mix

PFL

Prelade listen switch with LED

MUTEMIDI programmable FET mute with LED cuts all postfade signal sends.
Not muted by SOLO IN PLACE**RETURN INPUT 3(4)****AUX SENDS:**

Aux send level controls 1 & 2 for cue mix

LEVEL CONTROL

Return signal level to L-R

ASSIGN:

L-R routing switch

PAN CONTROL

To position signal in L-R mix

PFL

Prelade listen switch with LED

MUTEMIDI programmable FET mute with LED cuts all postfade signal sends
Not muted by SOLO IN PLACE**L(R) PEAK LED**

LED illuminates 3dB before overload. Detects pre-fader signal level

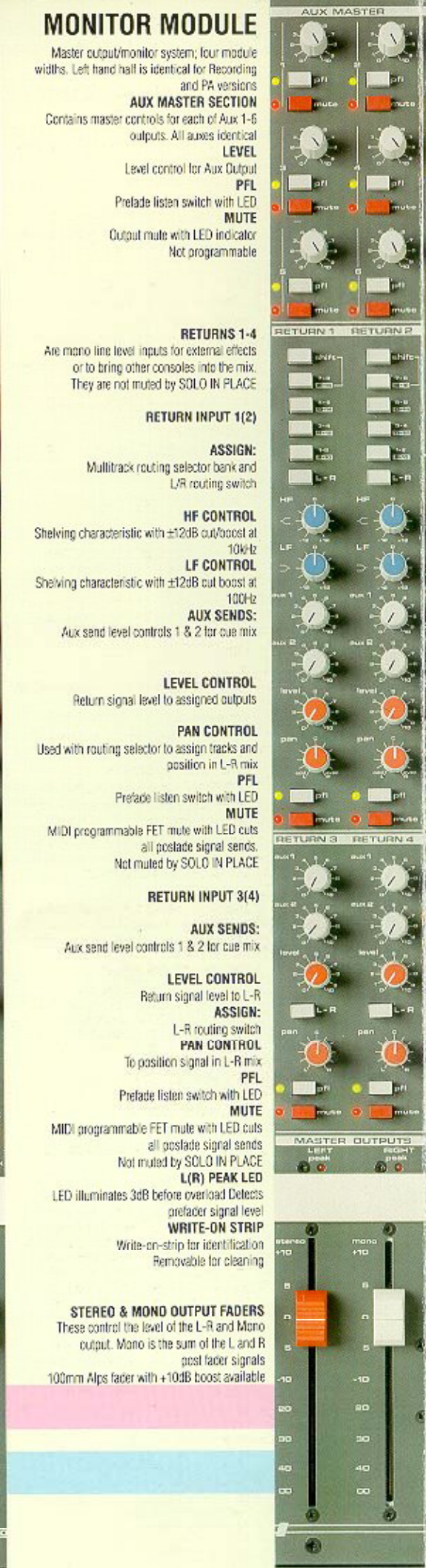
WRITE-ON STRIPWrite-on-strip for identification
Removable for cleaning**STEREO & MONO OUTPUT FADERS**These control the level of the L-R and Mono output. Mono is the sum of the L and R post fader signals
100mm Alps fader with +10dB boost available

PA MONITOR M355

TALKBACK MIC

XLR mic input (balanced with internal phantom power option)

L-R METERS

Illuminated VU meters for the L-R Master outputs, PFL level and Ext monitor input level

TALKBACK PRESELECT

Sends talkback signal to any or all of Aux 1, Aux 2 and L-R mix

TWO STATION INTERCOM SYSTEM

Compatible with Clearcom and Tecpro systems. Can speak to two systems selected by Station selectors. Listen to selected system(s) on control room monitor. Call lights indicate call function from external stations. Call button mutes incoming intercom and sends talkback mic to selected system(s)

EXT MONITOR

Source select switch for monitor output. Normally the L-R output, alternatively an external stereo source, eg dummyhead

MONO

Monos monitor signal

DIM

LED indicates monitors dimmed by active talkback

MUTE

Mutes monitor output

MONITOR LEVEL

Monitor output level control

HP LEVEL

Headphone level control HP programme is the same as monitor

'PFL IN USE' INDICATOR LED CHECK MODE

Selector switch between PFL or SOLO IN PLACE for check switches. PFL interrupts monitor LS and meters. Solo In Place mutes inputs which are not soloed

SOLO ON

Illuminated master solo enable with protective cover, prevents accidental operation during the performance

SOLO ENABLE CONTROLS

Master enable switches for channel and monitor SOLO IN PLACE. LINK combines channel and monitor SOLO IN PLACE operations. The separation of the solo systems allows SOLO IN PLACE to be accompanied by echo returns via monitors

TB LEVEL

Talkback microphone level control

HEADPHONE SOCKET

TALK SWITCH Press to activate talkback

MUTE PROCESSOR CONTROL PAD AND DISPLAY

Control keys RECALL, UPDATE, UP/DOWN manipulate storage and recall of mutes using on board memory organised as 33 patches. CLEAR wipes the current mute status. SHIFT selects the functions LOCAL, AUTO, DUMP and Channel no, which set up the MIDI interface for real time or time code based operation. Used with a MIDI sequencer all mute events can be replayed, the 33 memories are available for repeated or complex 'scene change' events. DUMP outputs memory contents to the sequencer using the Allen & Heath System Exclusive code, to create a library of MIDI data for the console. All mute events are output via MIDI in real time. RECALL events are also transmitted real time. MIDI is encoded with mute events in an additional compressed form which when replayed updates the console to the correct point in the song within two seconds. This permits drop-in recording. On replay the AUTO mode responds to the sequencer output and selects the correct mode following the drop-in point. MIDI data and a system overview are given on the introduction page of this literature.

PA MATRIX OUTPUT M326

SYSTEM OVERVIEW

Matrix output systems are a powerful tool for successful operation of the distributed loudspeaker packages often employed for theatre, tour and conference work. Creativity and control are the twin benefits of output matrixing; creative freedom for the sound designer to provide tailored sound coverage to distributed loudspeakers, and control where it is needed in the hands of the operator. SABER'S matrix outputs each derive programme from the eight group outputs, the main L-R output and an external line input. Standard systems have eight M326 matrix output modules.

OUTPUT METER

Switched between Group or Matrix output. Twenty segment LED bargraph having peak (fast rise, fast decay) characteristics and 45dB indicating range. 0dB reference level is +4dBu output level. Post fader group or matrix signal is displayed, refer also to Options.

GROUP TO L-R

LEVEL AND PAN controls for mixing the group output into the main L-R output. The on-off switch has green LED "on" indication. Group post-fader source is factory standard, refer also to Options.

MATRIX CONTROLS

Ten source level controls adjust the balance of the matrix output. Overall control of the output is made with the LEVEL control. EXT IN adjusts the contribution from the rear panel input jack (one per module). L-R adjusts the contribution from the main L-R mix (in mono). Controls 1-8 adjust the contributions of each group output to the matrix output. Group post-fader source is the factory standard, refer also to Options. External processors such as equalizers can be patched into the matrix via the pre-fader insertion point. Each matrix output receives operator talk back from the console M355 master module for cueing purposes. Each matrix has an individual TB ENABLE pushbutton for this function. PFL gives headphone and master meter indication of each matrix mix sourced before the Level control. MUTE switches the matrix output on or off and is programmable using the on-board Mute Processor memory system. Creative advances such as snap-shot scene change mutes and MIDI synchronisation to show tapes are easily achieved. The mute is achieved with high reliability solid state switching and is silent in operation.

GROUP CONTROLS

Inputs are routed to groups 1 to 8, are summed, pass via the rear panel insertion point connector to the GROUP FADER and then to the balanced XLR output panel connector. Above the write on strip is Group control CHECK (with LED indicator) which is dual function PFL or Solo-in-Place. PEAK indicates group pre-fader level. Operation of MUTE cuts the XLR output and the post fader sends to the mix, to the meter and matrix controls. Group Mute is programmable, like Matrix mute. The standard fader is 100mm Alps type calibrated with 10dB boost available.

USER CONFIGURABLE OPTIONS

Internal solderless jumper links allow reconfiguration of the system to individual requirements.

SYSTEM	STANDARD	OPTION
Group meter	post fader	pre fader
Group to L-R	post fader	pre fader
Group to Matrix	post fader	pre fader
Matrix meter	post fader	pre fader

In all cases post fader is also post-mute and pre fader is pre-mute.

CONNECTOR PANELS

The panels illustrated below are fitted at the rear of the console behind the appropriate modules

M301

Connector panel for eight M310 (M310X) input modules

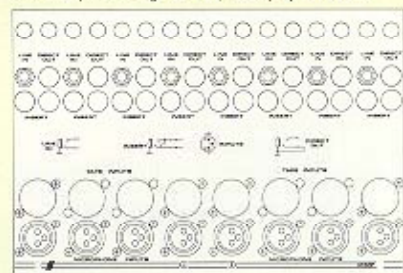

M300

Connector panel for eight M326 PA Matrix Output modules

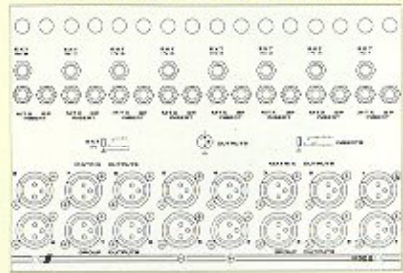

M306

Connector panel for four M360 stereo input modules.

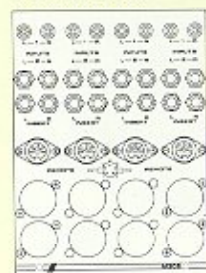

M305

Connector panel for the M355 PA monitor module



Not illustrated:

M307 For four M310 (M310X) modules.

Module blank four module width.

Single module blank

Connector blank eight module width

PART FILLED FRAMES are available by subtraction of input modules in multiples of four. The module blank is fitted and a fully wired M301 connector panel is fitted to permit subsequent module addition. Unless specified blanks are positioned in place of the highest numbered inputs. If eight module positions are required blank then a connector blank (no wiring) can be supplied.

Patchbay consoles are available prewired for M310 (M310X) at all input module positions only.

CONNECTIONS SUMMARY

MIC IN XLR female, balanced, pin 2 hot.

TAPE IN XLR female, balanced, pin 2 hot parallel with group monitor tape input.

LINE IN 1/4" jack, balanced, tip hot.

GROUP OUT L,R, MONO OUT, XLR male, balanced, pin 2 hot.

INSERT 1/4" jack, tip-send, ring-return.

DIRECT OUT, AUX OUT, MONITOR LS OUT, RETURN IN, STEREO TAPE IN, all 1/4" jack, unbalanced.

PA VERSIONS ONLY; COMMS IN/OUT, XLR pin 1 ground, pin 2 loop DC, pin 3 audio.

LAMP DC, connection to console BNC sockets.

RECORDING VERSIONS ONLY; MUTE CONTROL, locking 5 pin DIN connector output from module option M310X.

M306 ONLY: Input 1, RCA phono L & R inputs, unbalanced, either 300mV (std) or RIAA equalised (module M360X option).

REMOTE, locking 5 pin DIN connector, start/stop interface.

Input 2, 1/4" jack, balanced, L & R inputs.



OSCILLATOR/TALKBACK

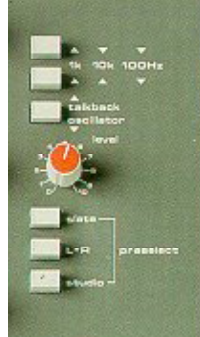

RECORDING MONITOR M350

TALK BACK/OSCILLATOR SECTION OSCILLATOR FREQUENCY SELECTOR

100Hz 1kHz 10kHz sinewave
TALKBACK/OSCILLATOR
Sends selected source to PRE-SELECTED outputs
LEVEL CONTROL

For oscillator/talkback level
PRESELECT
Output selector to slate, L-R and studio (OSC does not feed studio) Any or all may be selected

STUDIO

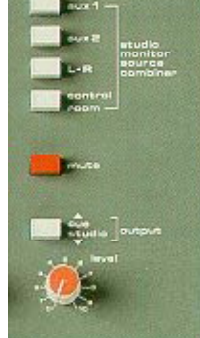

**STUDIO MONITOR SECTION
STUDIO SOURCE COMBINER**
Source combiner sums together the selected sources. Aux 1 and Aux 2 = Aux 1 > L Aux 2 > R; L-R selects output in stereo. Control room selects the same source as Control Room section below
MUTE
Mutes program to selected output, talkback still active
OUTPUT SELECT
Sends to CUE (normally headphones) or STUDIO (normally loudspeakers) rear panel sockets
LEVEL CONTROL
Cue/studio output level control

CONTROL ROOM



**CONTROL ROOM MONITOR SECTION
CONTROL ROOM SOURCE SELECTOR**
Selects control room monitor source, one of TAPE 1 (2 Track recorder), TAPE 2 (2 track recorder), STUDIO source or L-R output; all stereo. Also selects the source for L-R monitor meters
MONO Monos monitor signal
DIM
Dims Monitor output level (also activated by talk switch)
AUTOMUTE
'Fader open' mute of monitor output. Requires optional M310X input modules
MUTE Mutes monitor outputs
LS OUTPUT Main/alternate output selector
LEVEL CONTROL Monitor output level adjust
HP LEVEL CONTROL
Headphone level control not muted follows CR source

'PFL IN USE' INDICATOR LED
CHECK MODE
Selector switch between PFL or SOLO IN PLACE for CHECK switches. PFL interrupts monitor LS and meters Solo In Place mutes inputs which are not soloed.
SOLO ENABLE CONTROLS
Master enable switches for channel and monitor SOLO IN PLACE. LINK combines channel and monitor SOLO IN PLACE operations. The separation of the solo systems allows SOLO IN PLACE to be accompanied by echo returns via monitors
TALKBACK MIC Internal mic capsule for talkback
HEADPHONE SOCKET
TALK SWITCH Press to activate talkback
MUTE PROCESSOR CONTROL PAD AND DISPLAY
Control keys RECALL, UPDATE, UP/DOWN manipulate storage and recall of mutes using on board memory organised as 33 patches. CLEAR wipes the current mute status. SHIFT selects the functions LOCAL, AUTO, DUMP and channel no which set up the MIDI interface for real time or time code based operation. Used with a MIDI sequencer all mute events can be replayed, the 33 memories are available for repeated or complex 'scene change' events.
DUMP outputs memory contents to the sequencer, using the Allen & Heath System Exclusive code, to create a library of MIDI data for the console. All mute events are output via MIDI in real time. RECALL events are also transmitted real time. MIDI is encoded with mute events in an additional compressed form which when replayed updates the console to the correct point in the song within two seconds. This permits drop-in recording. On replay the AUTO mode responds to the sequencer output and selects the correct mode following the drop-in point. MIDI data and a system overview are given on the introduction page of this literature.



MON



DUAL GROUP M330 ODD MONITORS SECTION

One on each of 8 group modules
TAPE/LINE SELECTORS
Both up - Odd Group Output > L-R mix
Odd Group Output > Meter
Tape down - Multitrack Tape Return > L-R mix
Multitrack Tape Return > Meter
LINE down - Line Input > L-R mix
Source selected by TAPE switch > Meter
Used to bring an extra line level source into the L-R mix during re-mix
HF CONTROL
Shelving characteristic with ± 12 dB cut/boost at 10kHz corner frequency
LF CONTROL
Shelving characteristic with ± 12 dB cut/boost at 100Hz corner frequency
AUX SENDS:
Sends selected monitor source to Aux outputs. Pre/post selector for Aux sends 1&2
Aux send level controls 1&2 for cue mix
Aux 3/4 selector switch for Aux send level control for echo/effect
Internal links are provided for pre and post fade send
LEVEL CONTROL
Monitor signal level control to the L-R mix
PAN CONTROL
To position signal in L-R mix
CHECK
PFL or SOLO IN PLACE set by master control (with indicator LED)
MUTE
MIDI programmable FET mute with LED cuts all monitor post fade signal sends
EVEN MONITORS SECTION
One on each of 8 group modules. All functions as described above. Even Group Output, Tape or Line input is monitored

FADER REV
Reverses even group fader and even monitor level control.
FADER REV
Reverses odd group fader and odd monitor level control
8 TRACK SYSTEMS
Four M330 modules are supplied, giving eight outputs and eight monitors for eight track operation. Consoles are prewired to accept a further four M330 modules at a later date to give sixteen outputs and sixteen monitors, one four way module blank covers the space required at the right of the console. The choice of 16 track VU or Bargraph meterbridge is the same as for standard sixteen track systems.
16 TRACK SYSTEMS
Eight M330 modules are fitted giving 16 outputs and monitors with 16 VU or LED meters.
24 TRACK SYSTEMS
Eight M330 and four M335 modules are fitted giving 16 outputs and 24 monitors with 24 track meters. Connections are included for all 24 tracks in and out, XLR for non patchbay, multipin for patchbay version.

RECORDING MODULE SET (Patch Bay overleaf)
ODD & EVEN GROUP FADERS
100mm Alps fader with +10dB boost available



RECORDER SECTION
Four modules are supplied in addition to eight M330 modules and provide monitoring for tracks 17 to 24. Channel Tape Inputs 17 to 24 are internally parallel connected to these modules. Chose whether you mix tracks via channels or monitors by pushbutton selection. Eight rear jack sockets provide alternative Line inputs to the mix. When not used for track mixing these monitor sections provide inputs for synths, drum machines or echo return. Eight rear XLR sockets are provided (panel M308) for connection to recorder inputs 17 to 24. These outputs are duplicates of group outputs 1 to 8. Assignment to track 17 is achieved simultaneously with track 1 using channel routing switch 1-2. The recorder tracks 1 or 17 are switched between record and solo as required. The level to tracks 17 to 24 is controlled during recording with group faders 1 to 8. An insertion point is provided pre-fader for each monitor section.
The controls for odd number (17-23) and even number (18-24) monitors are identical.
LINE
Up selects Tape Input to the monitor section and meter.
Down selects Line Input to the mix. The meter continues to show Tape In.
HF CONTROL
Shelving characteristic EQ with ± 12 dB cut/boost at 10kHz corner frequency.
LF CONTROL
Shelving characteristic EQ with ± 12 dB cut/boost at 100Hz corner frequency.
AUX SENDS
Sends the selected monitor source to the Aux outputs
Pre/post selector for Aux sends 1 and 2
Aux send level controls 1 and 2
Aux 3/4 selector switch for the send control below Aux 3/4 send level control. Factory set post fader
Internal links allow alternative selection of pre or post fader send for the 3/4 level control
LEVEL CONTROL
Monitor signal level control to the L-R mix
PAN CONTROL
To position the signal in the L-R mix
CHECK
PFL or SOLO IN PLACE set by master control (with indicator LED)
MUTE
MIDI programmable FET mute with LED cuts all monitor post fade signal sends.

RECORDER SECTION
Four modules are supplied in addition to eight M330 modules and provide monitoring for tracks 17 to 24. Channel Tape Inputs 17 to 24 are internally parallel connected to these modules. Chose whether you mix tracks via channels or monitors by pushbutton selection. Eight rear jack sockets provide alternative Line inputs to the mix. When not used for track mixing these monitor sections provide inputs for synths, drum machines or echo return. Eight rear XLR sockets are provided (panel M308) for connection to recorder inputs 17 to 24. These outputs are duplicates of group outputs 1 to 8. Assignment to track 17 is achieved simultaneously with track 1 using channel routing switch 1-2. The recorder tracks 1 or 17 are switched between record and solo as required. The level to tracks 17 to 24 is controlled during recording with group faders 1 to 8. An insertion point is provided pre-fader for each monitor section.
The controls for odd number (17-23) and even number (18-24) monitors are identical.
LINE
Up selects Tape Input to the monitor section and meter.
Down selects Line Input to the mix. The meter continues to show Tape In.
HF CONTROL
Shelving characteristic EQ with ± 12 dB cut/boost at 10kHz corner frequency.
LF CONTROL
Shelving characteristic EQ with ± 12 dB cut/boost at 100Hz corner frequency.
AUX SENDS
Sends the selected monitor source to the Aux outputs
Pre/post selector for Aux sends 1 and 2
Aux send level controls 1 and 2
Aux 3/4 selector switch for the send control below Aux 3/4 send level control. Factory set post fader
Internal links allow alternative selection of pre or post fader send for the 3/4 level control
LEVEL CONTROL
Monitor signal level control to the L-R mix
PAN CONTROL
To position the signal in the L-R mix
CHECK
PFL or SOLO IN PLACE set by master control (with indicator LED)
MUTE
MIDI programmable FET mute with LED cuts all monitor post fade signal sends.

RECORDER SECTION
Four modules are supplied in addition to eight M330 modules and provide monitoring for tracks 17 to 24. Channel Tape Inputs 17 to 24 are internally parallel connected to these modules. Chose whether you mix tracks via channels or monitors by pushbutton selection. Eight rear jack sockets provide alternative Line inputs to the mix. When not used for track mixing these monitor sections provide inputs for synths, drum machines or echo return. Eight rear XLR sockets are provided (panel M308) for connection to recorder inputs 17 to 24. These outputs are duplicates of group outputs 1 to 8. Assignment to track 17 is achieved simultaneously with track 1 using channel routing switch 1-2. The recorder tracks 1 or 17 are switched between record and solo as required. The level to tracks 17 to 24 is controlled during recording with group faders 1 to 8. An insertion point is provided pre-fader for each monitor section.
The controls for odd number (17-23) and even number (18-24) monitors are identical.
LINE
Up selects Tape Input to the monitor section and meter.
Down selects Line Input to the mix. The meter continues to show Tape In.
HF CONTROL
Shelving characteristic EQ with ± 12 dB cut/boost at 10kHz corner frequency.
LF CONTROL
Shelving characteristic EQ with ± 12 dB cut/boost at 100Hz corner frequency.
AUX SENDS
Sends the selected monitor source to the Aux outputs
Pre/post selector for Aux sends 1 and 2
Aux send level controls 1 and 2
Aux 3/4 selector switch for the send control below Aux 3/4 send level control. Factory set post fader
Internal links allow alternative selection of pre or post fader send for the 3/4 level control
LEVEL CONTROL
Monitor signal level control to the L-R mix
PAN CONTROL
To position the signal in the L-R mix
CHECK
PFL or SOLO IN PLACE set by master control (with indicator LED)
MUTE
MIDI programmable FET mute with LED cuts all monitor post fade signal sends.

RECORDER SECTION
Four modules are supplied in addition to eight M330 modules and provide monitoring for tracks 17 to 24. Channel Tape Inputs 17 to 24 are internally parallel connected to these modules. Chose whether you mix tracks via channels or monitors by pushbutton selection. Eight rear jack sockets provide alternative Line inputs to the mix. When not used for track mixing these monitor sections provide inputs for synths, drum machines or echo return. Eight rear XLR sockets are provided (panel M308) for connection to recorder inputs 17 to 24. These outputs are duplicates of group outputs 1 to 8. Assignment to track 17 is achieved simultaneously with track 1 using channel routing switch 1-2. The recorder tracks 1 or 17 are switched between record and solo as required. The level to tracks 17 to 24 is controlled during recording with group faders 1 to 8. An insertion point is provided pre-fader for each monitor section.
The controls for odd number (17-23) and even number (18-24) monitors are identical.
LINE
Up selects Tape Input to the monitor section and meter.
Down selects Line Input to the mix. The meter continues to show Tape In.
HF CONTROL
Shelving characteristic EQ with ± 12 dB cut/boost at 10kHz corner frequency.
LF CONTROL
Shelving characteristic EQ with ± 12 dB cut/boost at 100Hz corner frequency.
AUX SENDS
Sends the selected monitor source to the Aux outputs
Pre/post selector for Aux sends 1 and 2
Aux send level controls 1 and 2
Aux 3/4 selector switch for the send control below Aux 3/4 send level control. Factory set post fader
Internal links allow alternative selection of pre or post fader send for the 3/4 level control
LEVEL CONTROL
Monitor signal level control to the L-R mix
PAN CONTROL
To position the signal in the L-R mix
CHECK
PFL or SOLO IN PLACE set by master control (with indicator LED)
MUTE
MIDI programmable FET mute with LED cuts all monitor post fade signal sends.

MON



DUAL MONITOR M335

RECORDER SECTION
Four modules are supplied in addition to eight M330 modules and provide monitoring for tracks 17 to 24. Channel Tape Inputs 17 to 24 are internally parallel connected to these modules. Chose whether you mix tracks via channels or monitors by pushbutton selection. Eight rear jack sockets provide alternative Line inputs to the mix. When not used for track mixing these monitor sections provide inputs for synths, drum machines or echo return. Eight rear XLR sockets are provided (panel M308) for connection to recorder inputs 17 to 24. These outputs are duplicates of group outputs 1 to 8. Assignment to track 17 is achieved simultaneously with track 1 using channel routing switch 1-2. The recorder tracks 1 or 17 are switched between record and solo as required. The level to tracks 17 to 24 is controlled during recording with group faders 1 to 8. An insertion point is provided pre-fader for each monitor section.
The controls for odd number (17-23) and even number (18-24) monitors are identical.
LINE
Up selects Tape Input to the monitor section and meter.
Down selects Line Input to the mix. The meter continues to show Tape In.
HF CONTROL
Shelving characteristic EQ with ± 12 dB cut/boost at 10kHz corner frequency.
LF CONTROL
Shelving characteristic EQ with ± 12 dB cut/boost at 100Hz corner frequency.
AUX SENDS
Sends the selected monitor source to the Aux outputs
Pre/post selector for Aux sends 1 and 2
Aux send level controls 1 and 2
Aux 3/4 selector switch for the send control below Aux 3/4 send level control. Factory set post fader
Internal links allow alternative selection of pre or post fader send for the 3/4 level control
LEVEL CONTROL
Monitor signal level control to the L-R mix
PAN CONTROL
To position the signal in the L-R mix
CHECK
PFL or SOLO IN PLACE set by master control (with indicator LED)
MUTE
MIDI programmable FET mute with LED cuts all monitor post fade signal sends.

ODD and EVEN INPUT FADERS
100mm Alps fader with 10dB boost available
There are no fader reverse switches. The faders are always input faders to the mix.

M303

Connector panel for eight M330 group modules.

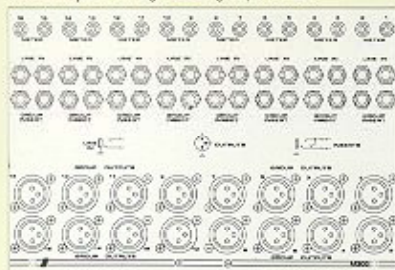

M308

Connector panel for four M335 dual monitor modules. On patchbay consoles, XLR and Insert connectors are not fitted, these facilities are provided on the patchbay.

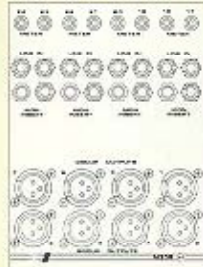

M302

Connector panel for the M350 Recording monitor module. For Patchbay consoles the L and R insertion points are transferred to the patchbay, all other connections remain as illustrated.

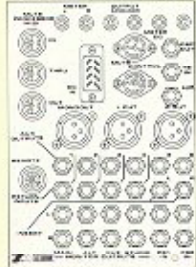

M301 PB

Connector panel for eight M310 input modules in Patchbay consoles. Not illustrated M307PB connector panel for four M310 input modules in Patchbay consoles.

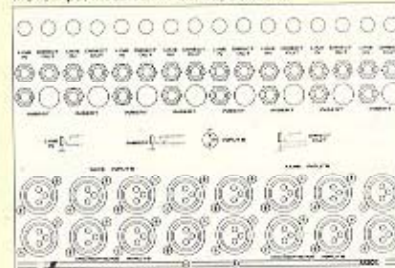

M303 PB

Connector panel for eight M330 group modules in Patchbay consoles.

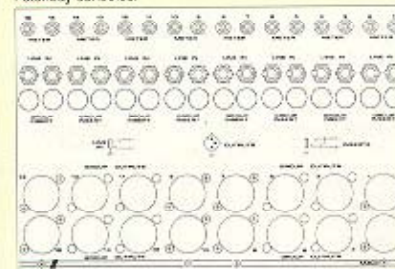

M309

Connector panel for Patchbay consoles.

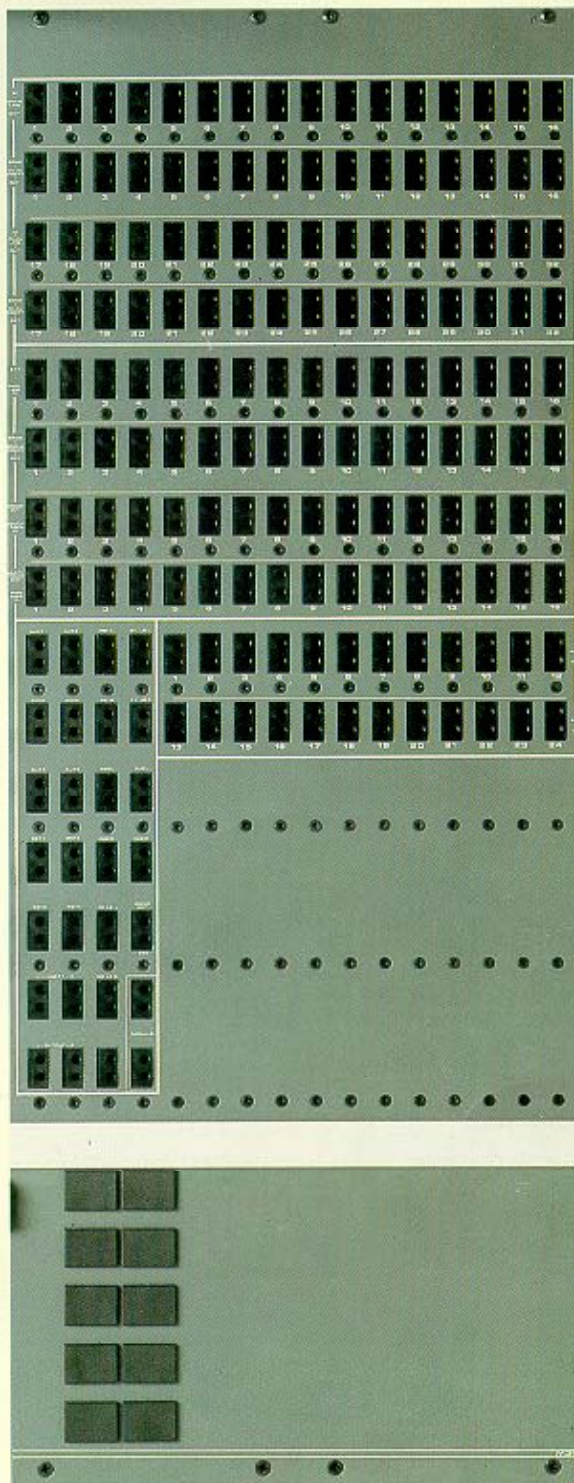
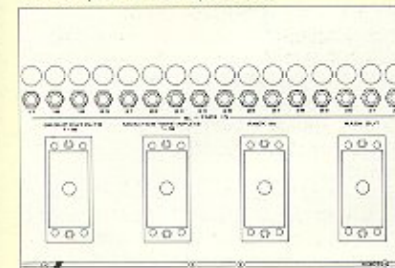

RECORDING PATCH BAY

CONNECTIONS

Tape Inputs for channels 17 to 32 1/4" jack, balanced. Group Outputs 1 to 16 EDAC 516 90 pin connector, balanced replacing XLR connectors. Outputs 1 to 8 are repeated on circuits 17 to 24 for connection to recorder inputs 17 to 24.

Monitor Tape Inputs 1 to 16, EDAC 516 90 pin connector, balanced takes the function of Tape Inputs on M301 input connector panels. These inputs are internally connected via the Patchbay to appear on input and group monitor sections of the console. Inputs 17 to 24 are provided on the multipin. These pass via the 1/4" jack sockets above and appear on Inputs and Monitors 17 to 24.

Rack In, Rack Out EDAC 516 90 pin connectors for patchbay circuits Rack In-Out 1 to 24. Multiway mating connectors and crimp or solder pins must be specified when required.

RECORDING PATCH BAY SYSTEM M390

In-board patchbay system for 16 track recording applications which occupies eight module spaces at the right hand end of the large frame only. Uses tip-ring-sleeve TT gauge system (Bantam jacks).

Line input, multitrack in/out, rack in/out, left, right and mono outputs are balanced. The remainder are unbalanced. Normally made internal connections are broken when a jack is inserted.

CHANNEL LINE IN 1-16 from channel line in rear panel sockets normally connected internally to the line select switch on input sections.

CHANNEL LINE OUT 1-16 from channel direct output.

CHANNEL INSERT SEND 1-16 from channel insert point output normally connected internally via:

CHANNEL INSERT RETURN 1-16 to the channel insert point input.

CHANNELS 17-32 Channels 17-32 are identical to channels 1-16.

EXT 1-16 from group line in rear panel sockets normally connected internal via:

MON LINE IN 1-16 to the line select switch on the group monitor section

GROUP INSERT SEND 1-16 from the group insert point output normally connected internally via:

GROUP INSERT RETURN 1-16 to the group insert point input.

GROUP OUT signal from main group outputs normally connected internally via:

MULTI-TRACK IN to the associated tape tracks from rear panel multi-pin connector.

MULTI-TRACK OUT outputs from the tape tracks from rear panel multi-pin connector normally connected internally via:

MON TAPE IN to the tape selector switches on the group monitor section and input section.

AUX 1-6 outputs from auxiliary masters normally connected internally via:

AUX 1-6 to the rear panel connectors.

PB1/PB2 rear panel sockets for stereo tape playback normally connected internally via:

PB1/PB2 to the tape inputs on monitor module M350.

ST LS/CUE signals for studio monitoring from monitor module normally connected internally via:

ST LS/CUE to studio LS and cue LS rear panel connectors

RET 1-4 sockets on rear of mixer normally connected internally via:

RET 1-4 to the return input section of monitor module.

CR LS signals from main control room loudspeaker outputs of monitor, normally connected internally via:

CR LS to the main LS rear panel connectors.

L/R INSERT signals from L-R mix, normally connected internally via:

L/R INSERT to the insert return on the monitor L-R section.

OUTPUT L/R from the L-R main outputs normally connected internally via:

OUTPUT L/R to the rear panel sockets.

MONO OUT from the mono sum output connected in parallel with the rear panel MONO connector.

OSC output from oscillator connected in parallel with the rear panel OSC connector.

PARALLEL is four jacks paralleled together to allow a signal to be split and sent to more than one location.

RACK IN 1-24 goes to rear panel multi-pin connector to connect to inputs of external effects equipment.

RACK OUT 1-24 goes to rear panel multi-pin connector to connect to outputs of external effects equipment. There is a normal connection between rack in and rack out.

USER DEFINED REMOTE SWITCH POSITIONS

Space is provided in the fader area below the patchbay for up to ten user installed switches.

24 TRACK PATCHBAY

(available Spring 1990)

Extra large frame versions of Saber are available having the 24 track version of the standard patchbay. Extra features provided on the panel are: eight input jacks normalised to eight monitor line input jacks 17 to 24; eight multitrack output jacks normalised to eight monitor tape input jacks 17 to 24; eight insert send jacks normalised to eight insert return jacks 17 to 24.

The connector system at the rear of the patchbay is as illustrated for 16 track patchbays. Output and input for tracks 17 to 24 are included on the multipins.

SPECIFICATION & AUDIO PERFORMANCE

ELECTRONIC PERFORMANCE

0dBu = 0.775 Vrms
0VU = +4dBu (1.23V) or -8dBu (300mV)
Reference Frequency = 1kHz

GAIN

Input to Group L-R or Mono Outputs
Channel Mic In: 10dB (PAD IN) to +70dB
Line In: -4dB to +36dB
Tape In: -12dB to +28dB
Monitor Tape In: 0dB or 12dB (linkable)
See connector illustrations for further data

FREQUENCY RESPONSE

Referred to 1kHz @ +4dBu, EQ Out
Mic In to Group Out, 40dB gain:
20Hz-20kHz +0/-1dB
Line/Tape In to L-R Out, 0dB gain:
20Hz-20kHz +0/-0.5dB

OUTPUTS

Balanced L, R, Mono, Group 1-16
Outputs: max level +27dBu with balanced termination of 600 ohms or more, +21dBu unbalanced.
Unbalanced Direct, Aux and monitor outputs: max level +21dBu with load of 2k ohms or more, +18dBu with 600 ohm load. Operating Level: 4dBu or -8dBu (linkable)

DISTORTION

THD+ Noise @ -20dBu output level, typical

Gain 1kHz 10kHz

Mic In to Group 70dB <0.01% <0.01%
Out:
Line/Tape to 0dB <0.007% <0.007%
L-R Out

EQUALISER

See module descriptions

CONNECTIONS

See panel drawings inside

POWER SUPPLY

Type RPS4, rack mounted unit including 48Vdc for phantom powered microphones.
AC input: 110V, 120V, 220V, 240V, 50/60Hz

NOISE PERFORMANCE

RMS Noise, 20kHz bandwidth, ref 0VU
Mic in, equivalent input noise -127dBm (200 ohm source)

Group Out, 1 input open, unity gain, EQ IN flat: -66dB
Group Out, 24 inputs routed, faders closed: -80dB
L-R Out, 1 input open, unity gain, EQ IN flat: -85dB
L-R Out, 24 inputs & 16 monitors routed, faders closed: -82dB

CROSSTALK

Referred to driven output 1kHz 10kHz
Muted, Input to L-R Out -95dB -80dB
On, Input to un-routed Group -95dB -80dB
L-R Separation -68dB -63dB

METERING

Standard meterbridge for all recording models includes 16 track meters plus L&R meters, optionally:
VU type: 18 or 26 illuminated analogue VU meters
BG type: 18 or 26 20-segment LED PPM bargraphs, -24 to +12dB
PA Versions have metering incorporated in modules.
M326 Group: 20-segment LED Peak bargraph, -36 to +15dB
M355 Monitor: illuminated analogue VU meters

CONSTRUCTION

All steel frame with grey eggshell stove enamel finish.
Recording versions supplied with rugged cantilever stand.
PA versions for table-top use, stand optional.
Padded arm rest and solid wood trims.
Modules individually modular, constructed of stove enamelled aluminium with stoved epoxy screen printed graphics.
Complete mixer serviceable from top and rear.



SABER PA Version including optional stand, lamp and microphone. 24:8:8 SPX + stand S.



SABER Recording Version including VU meters. 32:16:16 MVU



SABER Recording Version including patchbay and Bargraph meters. 32:16:16 LBGPB

DIMENSIONS mm (ins)

MODEL	WIDTH	FRONT-BACK	HEIGHT
S Frame, 36 module capacity:	1243(48.9)	800(31.5)	1060(41.75)
M Frame, 44 module capacity:	1503(59.2)	800(31.5)	1060(41.75)
L Frame, 52 module capacity:	1763(69.4)	800(31.5)	1060(41.75)
XL Frame, 60 module capacity:	2023(79.6)	800(31.5)	1060(41.75)
PA Versions	S,M,L	800(31.5)	230(9)
Power Supply RPS4	18inch rack	170(7)	3U

STANDARD MODELS

Recording versions: including meterbridge and stand, and RPS4;

Small Frame	Medium Frame	Large Frame	Extra Large Frame (available Spring 1990)	
24:8:8 SVU	32:8:8 MVU	40:8:8 LVU	48:8:8 XLVU	[See Note 1
24:8:8 SBG	32:8:8 MBG	40:8:8 LBG	48:8:8 XLBG]See Note 1
24:16:16 SVU	32:16:16 MVU	40:16:16 LVU	48:16:16 XLVU	
24:16:16 SBG	32:16:16 MBG	40:16:16 LBG	48:16:16 XLBG	
-	28:16:24 MVU	36:16:24 LVU	44:16:24 XLVU	
-	28:16:24 MBG	36:16:24 LBG	44:16:24 XLBG	
Recording Patchbay Versions				
-	-	32:16:16 LVUPB	40:16:16 XLVUPB	
-	-	32:16:16 LBGPB	40:16:16 XLBGPB	
-	-	28:16:24 LVUPB	36:16:24 XLVUPB	
-	-	28:16:24 LBGPB	36:16:24 XLBGPB	
P.A. Versions: including RPS4, and meters on output modules. Excluding stand.				
24:8:8 SPX	32:8:8 MPX	40:8:8 LPX	48:8:8 XLPX	

Note 1: 8-track version having 4 x M330, prepared for 8 x M330.

SABER BLOCK SCHEMATICS

M310/M310X

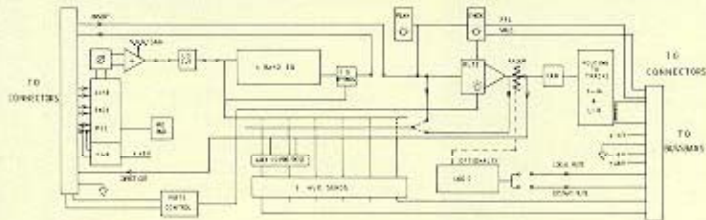

M360

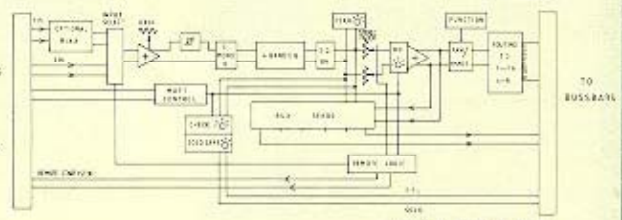

M326

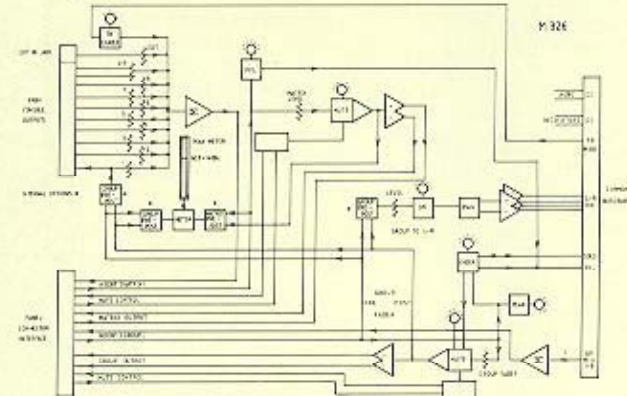

L(R) M350/M355

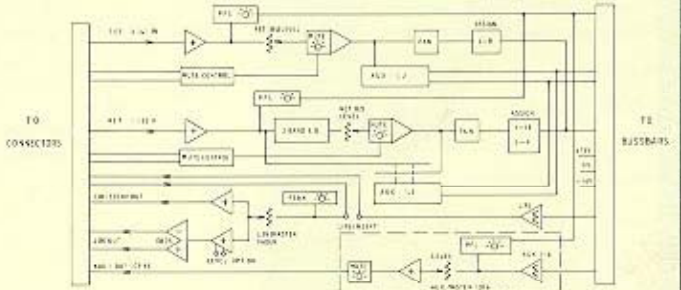

M335

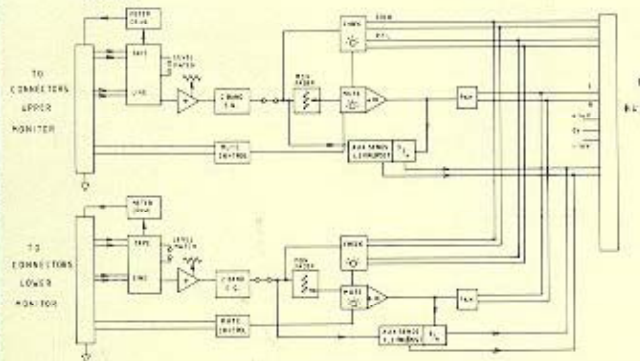

M330

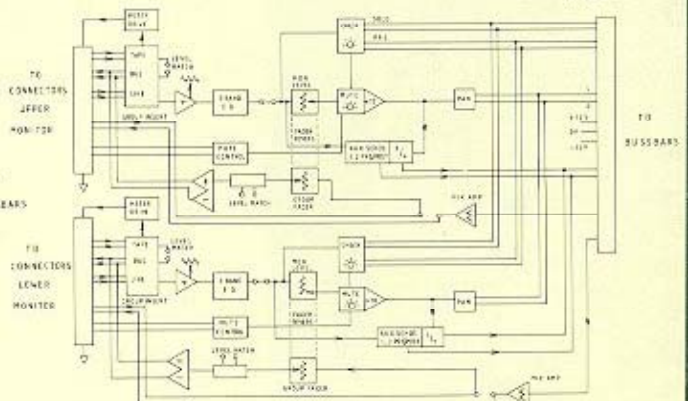

SYSTEM

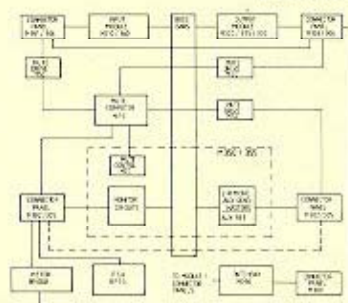

M350

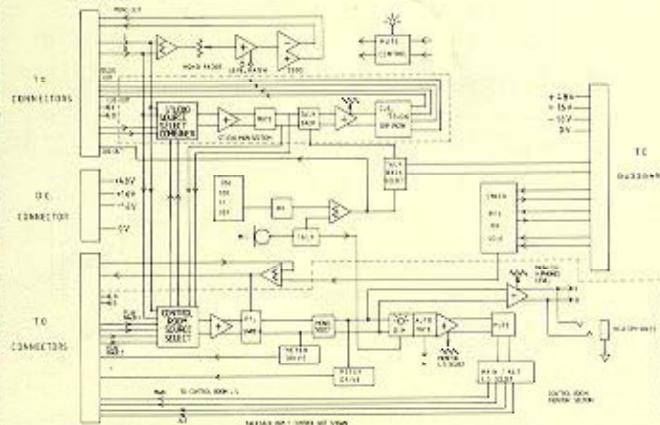

M355

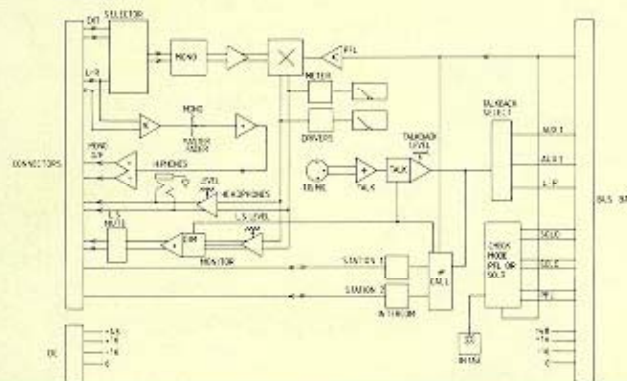

UK
 Head Office
 69 Ship Street
 Brighton BN1 1AE
 Tel: 0273 23346
 Fax: 0273 821767

USA
 5 Connair Road
 Orange
 Connecticut 06477
 Tel: 203 795 3594
 Fax: 203 795 6814

In line with our policy of continuous product improvement, we reserve the right to amend the design and specification of equipment without notice.

Designed by Bernie James West Associates Limited. Printed in England.



A102-4M1150

ALLEN & HEATH SABER SERVICE MANUAL

Table of Contents

1.0 Introduction

- 1.1 Maintenance programme
- 1.2 Service record
- 1.3 Technical bulletins
- 1.4 Guarantee and service policy
- 1.5 Accessories and options
- 1.6 Spare parts
- 1.7 Specification
- 1.8 Dimension drawings
- 1.9 Frame cross section

2.0 Module exchange

- 2.1 Module addition
- 2.2 Module removal and replacement
- 2.3 Customer options

M310
M320
M330
M350
M325
M355
M360

3.0 Adjustments

- 3.1 Meter calibration
- 3.2 Balanced output symmetry
- 3.3 Module assignment

4.0 Technical description

- 4.1 Console outline technical description
- 4.2 Check system PFL and solo
- 4.3 Audio mute element
- 4.4 Metering, VU
- 4.5 Metering, LED
- 4.6 Mute Processor system including MIDI
- 4.7 Power supply RPS3

5.0 Fault diagnosis - basic console fault finding

- 5.1 DC distribution
- 5.2 Smoke, fuses and sparks
- 5.3 Audio signal and DC measurements
- 5.4 LED meter fault diagnosis
- 5.5 Mute Processor fault diagnosis

Stock Issue
No. No.

Saber Service Manual
January 1989

AP0083 1

ALLEN & HEATH SABER SERVICE MANUAL

6.0 Schematics and circuit diagrams

Title	Dwg No	Issue No
Allen & Heath Component references		
Power supply RPS3 connection details	679	2
RPS3 pcb component identification	BW222	1
RPS3 regulator pcb circuit diagram	694	1
Saber mainframe wiring diagram	664	1
Saber meterbridge wiring diagram	665	1
LED meter circuit diagram	MBD189	4
LED master pcb component identification	BW223	1
LED display pcb component identification	BW223	1
LED rectifier pcb component identification	BW223	1
Mute processor computer pcb component identification	BW224	1
Mute processor computer pcb circuit diagram	MBD190	2
Mute processor keyboard pcb component identification	BW225	1
Mute processor keyboard pcb circuit diagram	698	1
Mute processor slave pcb component identification	BW226	1
Mute processor slave pcb circuit diagram	A164	2
Mute processor wiring	663	1
Input module M310(X) component identification	BW323	1
Input module M310(X) circuit diagram	667	1
Input module M360 component identification	BW324	1
Input module M360 circuit diagram	668	1
Output module M320 component identification	BW325	1
Output module M320 circuit diagram	669	1
Output module M325 component identification	BW326	1
Output module M325 circuit diagram	686	1
Output module M325 meter component identification	BW327	1
Output module M325 meter circuit diagram	666	1
Output module M330 component identification	BW328	1
Output module M330 circuit diagram	687	1
Monitor master module M350 L/R component identification	BW329	1
Monitor master module M350 L/R circuit diagram	688	1
Monitor master module M350 monitor component identification	BW330	1
Monitor master module M350 monitor circuit diagram	689	1
Monitor master module M355 L/R, refer to M350		
Monitor master module M355 monitor component reference	BW331	1
Monitor master module M355 monitor circuit diagram	690	1
Balanced output detail for M320, M325, M330	691	1
Balanced output circuit, EBO, for M350, M355	A137	2
E.B.O. Component identification	BW192	2
M360 RIAA module component identification	MBD111	1
M360 RIAA module circuit diagram	MBD111	1
Patchbay M390 assembly diagram	702	1
Patchbay M390 pcb assembly drawing	703	1
Patchbay M390 pcb circuit types 1 and 2	681	1
Patchbay M390 pcb circuit type 3	682	2
Patchbay M390 pcb circuit type 4	684	1
Patchbay M390 pcb circuit type 5	683	1

NOTE: Module M335 is a derivative of M330. For service purposes refer to M330 details.

1.0 INTRODUCTION

1. Scope

This manual contains technical information for purposes of adjustment, fault diagnosis, fault repair, and identification of replacement spare parts.

The contents apply to SABER RECORDING and SABER PA versions of the finished product.

When additions are made to the range of components there will be additional text released for technical purposes.

From time-to-time Technical Bulletins will be issued that are intended for addition to this manual. Because these may affect service procedures the Technical Bulletin section is located at the beginning of this manual.

During the production life of the components of the SABER series it may be necessary from time-to-time to vary details of assembly to maintain performance, enhance performance or introduce variations. Should you find that the hardware in-field differs from the details shown here consider seeking verification from Allen & Heath direct prior to major service operations.

2. Method of Use

This manual is written for use by service personnel having skill in the use of the following equipment and techniques:

- Hand Soldering tools and techniques
- Voltage, current, and resistance measurement by multimeter instrument
- Identification of components by reference code, colour code and function
- Voltage measurement of audio and noise signals by precision AC meter
- Voltage measurement using oscilloscope
- Audio amplifier basic principles
- Logic gate basic principles
- Audio interconnection basic principles

Each component is illustrated in this manual by circuit diagram and component overlay drawing for pcbs. There is a technical description of common systems and systems unique to the SABER series.

In order to comply with warranty terms service work may be undertaken only by authorised Allen & Heath service agents during the period of warranty.

1.1 MAINTENANCE PROGRAMME: SABER, all versions

1. **Routine maintenance schedule**
 - a) preventative maintenance to minimise wear and tear. Refer to Service Policy.
 - b) replacement of Mute Processor RAM back-up battery. Recommended after 5 years operation. Refer to illustrations for Mute Processor Computer.
2. **Performance proving and adjustment**
 - a) Meter calibration . Refer to section 3.1.
 - b) Output symmetry. Refer to section 3.2.
 - c) Audio system test. Refer to operators manual. Section "Check out".
 - d) Verification of power supply operation. Refer to section 4.7.
3. **Service Repair Schedule**
 - a) Electro mechanical parts as wear occurs, eg. faders and switches. No fixed schedule.
 - b) Electromechanical and electronic component replacement in the event of failure.

ALLEN & HEATH SABER SERVICE MANUAL

1.2

SERVICE RECORD

Fault	Action	Date	Operator
-------	--------	------	----------

ALLEN & HEATH SABER SERVICE MANUAL

1.3 TECHNICAL BULLETINS



*Professional
Audio Equipment*

69 Ship Street,
Brighton BN1 1EA
United Kingdom. **23346**
Telephone: (0273) 24928
Telex: 878235 MBI AHB G
Fax: (0273) 821767

TECHNICAL BULLETIN

0326-372070

ATTENTION SERVICE DEPARTMENT

Ref: SABER 02

Aid to fault diagnosis : global excess noise fault.

There have been two reports of excess noise which degrades all audio outputs and the 16 group outputs. Two different causes have been identified:

1. RPS3 regulator pcb regulator IC UA723 defective. In this case the noise is present on only one DC output and is of a continuous nature. The noise quality is typical for a noisy linear amplifier. Replacement of the IC corrects the fault.
2. RPS3 DC output terminals "microphonic". In this case deflection of the RPS3 bottom panel provokes the noise, which can be intermittent. The noise quality has a greater low frequency content than a typical op amp noise fault. The cause is very small resistance changes in the crimp blade termination. To correct the fault solder the wire to the crimp blade. Remove the blade and apply contact lubricant to the sliding surfaces.

Ted Rook
Allen & Heath, Brighton

25th January 1989



*Professional
Audio Equipment*

69 Ship Street,
Brighton BN1 1EA
United Kingdom.

Telephone: (0273) ~~24020~~ 23346
Telex: 878235 MBIAHB G
Fax: (0273) 821767

22nd May 1989

TECHNICAL BULLETIN 06

Saber component change and documentation update.

On PCB type MONITOR which is part of modules type M350 and M355 the following component change took place on 10th May 1989, serial number M31093:

<u>Reference</u>	<u>Previous Type</u>	<u>New Type</u>
Q9	ZTX109C (NPN)	BC637
Q10	BC214 (PNP)	BC638

Pin outs



Failure of either or both transistors causes loss of + and - 7.5v DC bias to logic gate ICS in the monitor audio path. Logic functions 'DIM' 'MONO' 'PFL' are lost. Audio is absent or breaks through distorted at high amplitude.

If either or both transistors are found to have failed then fit the new types in locations Q9 and Q10.

These parts are not included with the standard spares kit. Two of each component are included free of charge with this bulletin. Unless of course your console has a serial number greater than M31093.

TECHNICAL BULLETIN

ATTENTION SERVICE DEPARTMENT

Ref: SABER 07 CORRECTIONS TO OWNER MANUAL.

Section 1.4 page 1, Check out

- Para 3) Add at the end: Release OSC L-R.
- Para 4) Use the monitor mutes to turn off each in turn rather than closing each group fader. At the end of the test there should be 16 muted monitors.
- Para 5) Routing to groups 9 to 16 requires use of the SHIFT pushbutton.
- Para 6) Add at the beginning; Release OSC SLATE and check that monitors 1-16 are muted.

Section 2.1.1. Page 2 Solo - in - place:
The first paragraph should be ignored . Solo - in - place is correctly described in the second paragraph.

Section 3.1 Page 3 Multipin connector part numbers:
for plug body 516 040 000 301
read 516 090 301

Ted Rook
Allen & Heath, Brighton

31st. August 1989

ALLEN & HEATH SABER SERVICE MANUAL

1.4 GUARANTEE

Saber products are made in the U.K. by ALLEN & HEATH BRENELL LTD, and are guaranteed against defective parts and workmanship for a period of ONE YEAR from the date of purchase by the original owner.

The defective component or module should be returned to Allen & Heath or its authorised agent and subject to the following conditions will be repaired or at our option replaced free of charge for labour and materials.

Conditions:

- 1) The equipment has been installed and operated in accordance with the instructions in the Operators Manual
- 2) The equipment has not been subject to abuse, neglect or alteration other than described in the Operators Manual
- 3) Any necessary adjustment, alteration or repair has been made by Allen and Heath or its authorised agent
- 4) The defect must be notified promptly
- 5) The defective item is to be returned carriage prepaid to Allen and Heath or its authorised agent and proof of purchase made available on request

Units to be returned should only be packed in the original AHB packing and be accompanied by the Power Unit

These terms of guarantee apply to U.K. sales. In other territories, the terms may vary according to legal requirements.

ALLEN & HEATH SABER SERVICE MANUAL

Sales Headquarters:

ALLEN & HEATH
69 Ship Street
Brighton
BN1 1AE
United Kingdom

Tel: +44 (0) 273 23346
Tlx: 878235 MBI G
Fax: +44 (0) 273 821767

ALLEN & HEATH USA
5 Connair Road
Orange
Connecticut 06477
United State of America

Tel: +1 203 795 3594
Fax: +1 203 795 6814

Factory:

ALLEN & HEATH
Kernick Industrial Estate
Penryn
Falmouth
Cornwall
TR10 9LU
United Kingdom

Tel: +44 (0) 326 72070
Fax: +44 (0) 326 77097

ALLEN & HEATH SABER SERVICE MANUAL

Service Policy and Spare Parts

Allen & Heath products are designed to give trouble free service with the minimum of attention. Repair under warranty is the responsibility of the selling agent who has been equipped with spare parts and technical manuals, and has the relevant repair equipment and service personnel.

In territories outside the U.K. refer to the selling agent for details of service and repair procedures.

Outside warranty, owners may use the services of the service agent or undertake service themselves. Spare parts and manuals are chargeable.

Service item availability:

- | | |
|-------------------|-----------------------------------------------------------------------------------------------------------------------|
| Owner manual | - order Saber Recording Owner Manual
OR Saber P.A. Owner Manual |
| Technical Manual | - order Saber Service Manual
same for all models |
| Spare Parts | - order Saber Spares Kit
see contents overleaf
order Spare Modules and PSU
contact sales agent |
| Technical Support | - contact Sales Agent first if problems arise
contact Allen & Heath |
| Packing | - cartons for module shipping are available on request |

Preventive Maintenance

Owners can prolong the service life of the equipment and minimise service costs by attention to a few simple points:

Protect the operating surface of the console from liquid spillage

During building/moving operations, cover the console to protect it from dust entry and accidental damage

Clean the controls and panels using a cloth dampened with a little dilute detergent. Avoid the use of aerosol and liquid solvent cleaners. Avoid the use of abrasive cleaning materials. The white write-on strip slides off for cleaning purposes

Ensure that your power supply is installed with adequate support and free air flow from below to provide ventilation for cooling. Do not expect a power supply sitting on carpeted floor to remain at normal operating temperature indefinitely. Do not use any other type of power supply than the one supplied with the console, type RPS3.

1.5 Accessories and Options

	Description	Order Code
	4 way module blank	ZX300-049
M301	8 way input connector panel	ZX300-004
M301PB	8 way input connector panel for PB	ZX300-055
M306	4 way stereo connector panel	ZX300-058
M307	4 way input connector panel	ZX300-066
M307PB	4 way input connector panel for PB	ZX300-061
	8 way connector blank panel	ZX300-060
M310	Input module	ZX300-601
M310X	Input module	ZX300-602
M320	Group Module (single group)	ZX300-603
M325	Group Module (live sound group)	ZX300-606
M330	Group Module (dual group)	ZX300-604
M350	Recording Master Module	ZX300-603
M355	Live Sound Master Module	ZX300-616
M360	Stereo Input Module	ZX300-620

Mute Buttons

Spare input and group modules are supplied without the numbered mute buttons. These should be ordered separately if required.

Order within the following code sequence - Saber mute button No. 1 AJ0301

Saber mute button No. 32 AJ0332

IE. Mute button no. 3 has part no. AJ0303

Write-on strip 655/2 - Small Frame (36 way)	AK0327/S
Medium Frame (44 way)	AK0327/M
large Frame (52 way)	AK0327/L
Small Frame Stand	ZX300-036
Medium Frame Stand	ZX300-037
Large Frame Stand	ZX300-038
RPS3 Rack Mounting Power Supply - 220/240 Vac	ZX300-607
110 Vac	ZX300-608
EDAC 90 pin Connector - Complete	ZX300-065
Service Manual	AP0083
Saber Standard Spares Kit	Order by description

WITH STANDARD FORMAT THE DIMENSION SHOWN HERE IN mm ARE USED TO CLEAR AUX 1/2 CONTROLS.

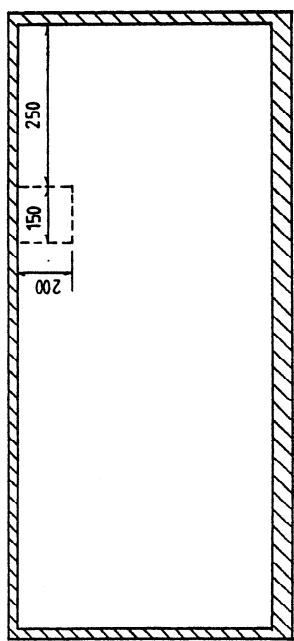

SHADED AREA SHOWS LOAD BEARING SURFACES FOR LID OF FLIGHT CASE FOAM TO REST ON. AVOID LOADS ON CONTROL SURFACE.

HIGHEST CONTROL FOUND ON MASTER MODULE M355 AUX 1/2 AVOID FOAM PRESSURE ON THESE TWO CONTROLS. SEE PLAN VIEW.

WIDTH OF LOAD BEARING SURFACE.

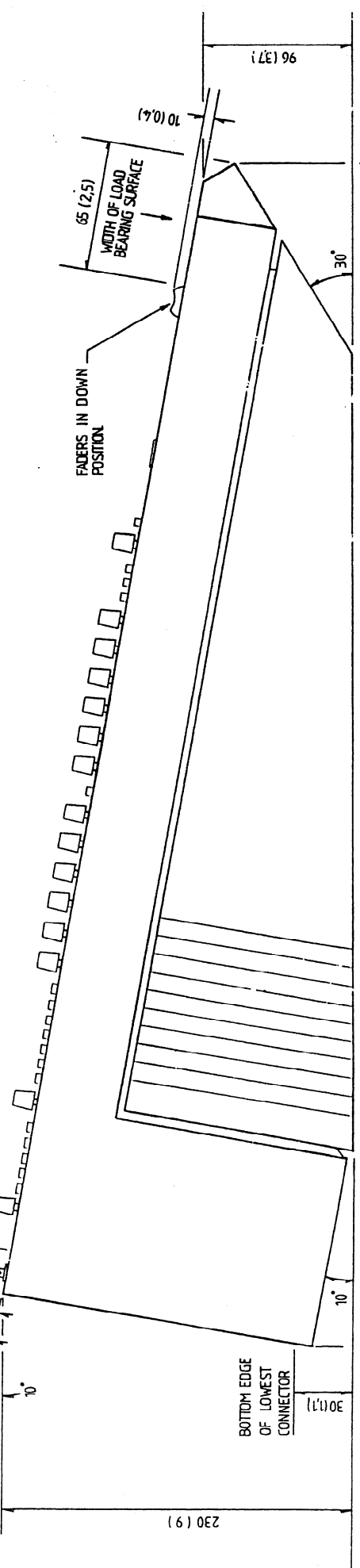
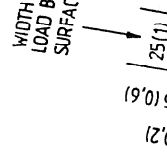

WIDTH OF LOAD BEARING SURFACE.

WIDTH OF LOAD BEARING SURFACE.

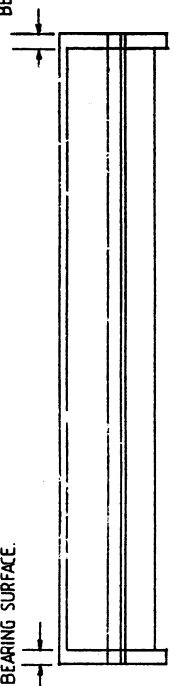

SABER SERIES P.A. VERSION FOR FLIGHT CASE CONSTRUCTION.

**DIAGRAM SHOWING INTERNAL ARRANGEMENT
AND FIXING POINTS.**

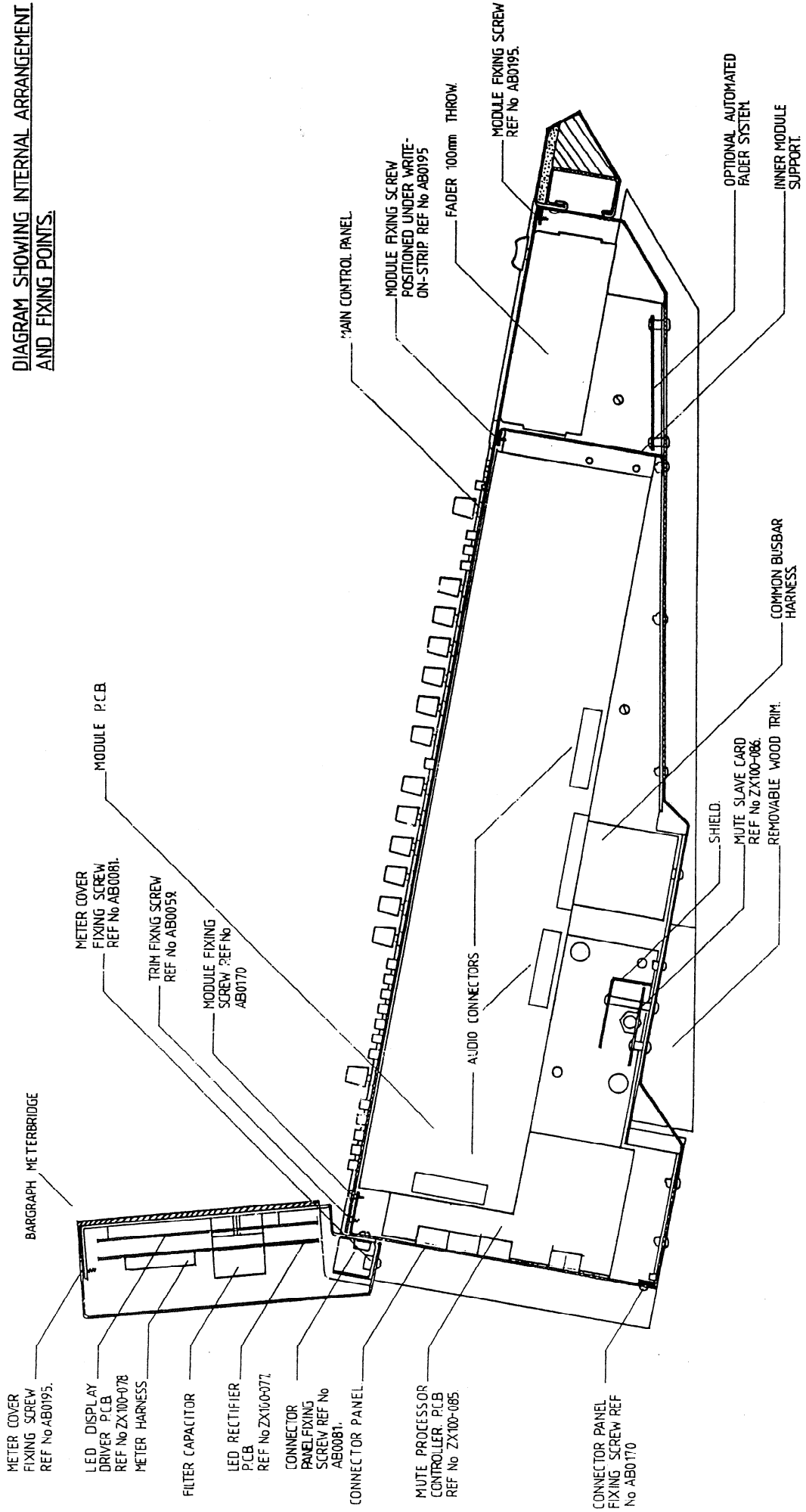

ALLEN & HEATH SABER SERVICE MANUAL

1.6 Ordering Spare Parts

- 1) Standard Saber Spares Kit: order code - **SABER STANDARD SPARES**. All items listed below are included in a cabinet of drawers. The purpose is to enable in-field service repairs to recording and live sound versions by component replacement independent of Allen & Heath's factory. Common resistors, capacitors and soldering equipment are not supplied.
- 2) Individual spare parts from the list may be ordered. Please include order reference code for the part required.
- 3) This list replaces the list in the owner manuals dated October 1988.

Description	Order Code	Qty
Fader, Alps 100 mm, 10 k, log	AI0091	5
Fader Knob	AJ0048	5
Fader Screw, M3 CSK	AB0215	10
Module Fixing Screws - Countersunk Head 6AB	AB0195	10
Pan Head 6AB	AB0170	10
Spire Clip (Nut clip) 6AB	AB0258	10
Pan Head 4AB, module assy	AB0057	10
Joint block, Nylon, A138	AB0253	5
Pots - GAIN, Alps 10k C AHB 3	AI0053(+Nut)	5
- LEVEL, Alps 100k AHB 4	AI0054 ..	5
- STEREO LEVEL, Alps 100k Ax2 AHB5	AI0055 ..	5
- HF, LF, EQ, Alps 100k B, CC AHB 2	AI0052 ..	5
- MF, SWEEP, Alps, 100k Cx2 AHB 15	AI0130 ..	5
- LEVEL, Alps 10k A, AHB 16	AI0131 ..	5
- PAN, Alps 10k B, CC ABH 1	AI0051 ..	5
Knobs - Knob Body, TP110-006 Grey	AJ0058	10
Knob Cap - RED C111	AJ0063	10
- GREY C111	AJ0066	10
- GREEN C111	AJ0061	10
VU Meter Complete, SQ10 Type	AD0011	2
VU Meter Lamp Complete, SQ10 Type	AD0013	10
Jack Socket, 1/4" 3-pole, switched, metal bush	AL0369	5
Mute processor Battery, NICAD 6.3V, MP3	AP0019	1

ALLEN & HEATH SABER SERVICE MANUAL

Tools -	Ring Spanner M6 (10mm AF)	AT0003	1
	Screw Driver No. 2	AT0002	1
	Screw Driver No. 1	AT0004	1
Switches -	MUTE, PCB 2PCO, momentary	AL0374	5
	GENERAL, PCB 2PCO, latched	AL0162	5
	GENERAL, PCB 4PCO, latched	AL0333	5
LEDS -	T1 Single RED	AE0086	5
	T1 Single YELLOW	AE0084	5
	Display, 10 Green	AE0257	1
	Display, 7 Red 3 Green	AE0258	1
ICs -	TL072P Dual Operational Amplifier	AE0046	10
	NE5532 Dual Operational Amplifier	AE0221	10
	4051B CMOS Gate	AE118	5
	4052B CMOS Gate	AE0139	5
	4066B CMOS Gate	AE0116	5
	4071B CMOS Gate	AE0251	2
	4099B CMOS Gate	AE0238	2
	4518B CMOS Gate	AE0259	2
	LM3915 LED Driver	AE0136	2
	6N136 Opto isolator	AE0222	1
	LM339 Quad Comparator	AE0071	2
Transistors -	ZTX109c	AE0020	10
	BC214c	AE0031	10
	J111 FET	AE0083	5
Fuses -	20 x 5mm AC 1A Anti-surge for 220/240 V operation	AL0305	5
	20 x 5mm AC 4A Anti-surge	AL0394	5
	20 x 5mm DC 0.5A Anti-surge	AL0297	5

Additional Items (Not included with Standard Spares)
Complete tested pcb assemblies

Led Bargraph master pcb	ZX100 079
Led Bargraph Display + Rectifier combination	ZX100 078 + ZX100 077
EBO balanced output module +6dB Version	ZX100 111
RPS3 regulator pcb ± 16 v 3A DC	ZX300 020
Mute processor pcb	ZX100 085
Mute processor Slave pcb	ZX100 086
Mute processor Remote pcb	ZX100 087

1.7 Specification

Electronic Performance

0dBu = 0.775 Vms
 0 VU = +4dBu (1.23 V) or -8dBu (300 mV)

Reference Frequency = 1kHz

Gain

Input to Group L-R or Mono outputs
 Channel Mic In: 10dB (PAD IN) to +70dB

Line In: -4dB to +36dB

Tape In: -12dB to +28dB

Monitor Tape In: 0dB or 12dB (linkable)

See connector illustrations for further data

Frequency Response

Referred to 1kHz @ +4dBu, EQ out

Mic In to Group Out, 40dB gain:

20Hz - 20kHz +0/-1dB

Line/Tape In to L-R Out, 0dB gain:

20Hz - 20kHz +0/-0.5dB

Outputs

Balanced L, R, Mono, Group 1-16

Outputs: max level +27dBu with balanced termination of 600 ohms or more. +21dBu unbalanced

Unbalanced Direct, Aux and monitor outputs: max level +21dBu with load of 2K ohms or more, +18dBu with 600 ohm load. Operating

Level: 4dBu or -8dBu (linkable)

Distortion

THD + Noise @ +20dBu output level, typical

	Gain	1kHz	10kHz
Mic In to Group Out:	40dB	<0.02%	<0.03%
Line/Tape to L-R Out:	0dB	<0.01%	<0.02%

Equaliser

See module descriptions

Connections

XLR phase :
 1/4" jack :

Noise Performance

RMS Noise, 20kHz bandwidth, ref 0 VU
 Mic in, equivalent input noise -127dBu (200 ohm source)

Group Out, 1 input open, unity gain EQ IN/flat: -80dB

Group Out, 24 inputs routed, faders closed: -79dB

L-R Out, 1 input open, unity gain, EQ IN/flat: -77dB

L-R Out, 24 inputs routed, faders closed: -76dB

Crosstalk

Referred to driven output 1kHz 10kHz

Muted, Input to L-R Out -80dB -63dB

On, Input to L-R Out -70dB -65dB

L-R Separation -65dB -60dB

Metering

Standard meterbridge for all recording models includes 16 track meters plus L&R meters, optionally:
 VU type: 18 illuminated analogue VU meters

BG type: 18 20 segment LED PPM bargraphs, -24 to +12dB

PA Versions have metering incorporated in modules:

M325 Group: 20 segment LED Peak bargraph, -36 to +15dB

M355 Monitor, illuminated analogue VU meters

Power Supply

Type RPS3, rack mounted unit including 48 Vdc for phantom powered microphones
 AC input: 110V, 120V, 220V, 240V, 50/60Hz

pin 2 +, pin 3 -, pin 1 ground.
 balanced tip +, ring -, case ground.
 unbalanced tip +, ring and case ground.
 stereo tip left, ring right.
 insert tip send, ring return.

SABER SERIES OVERALL DIMENSIONS
52 WAY CHASSIS

mm (inches)

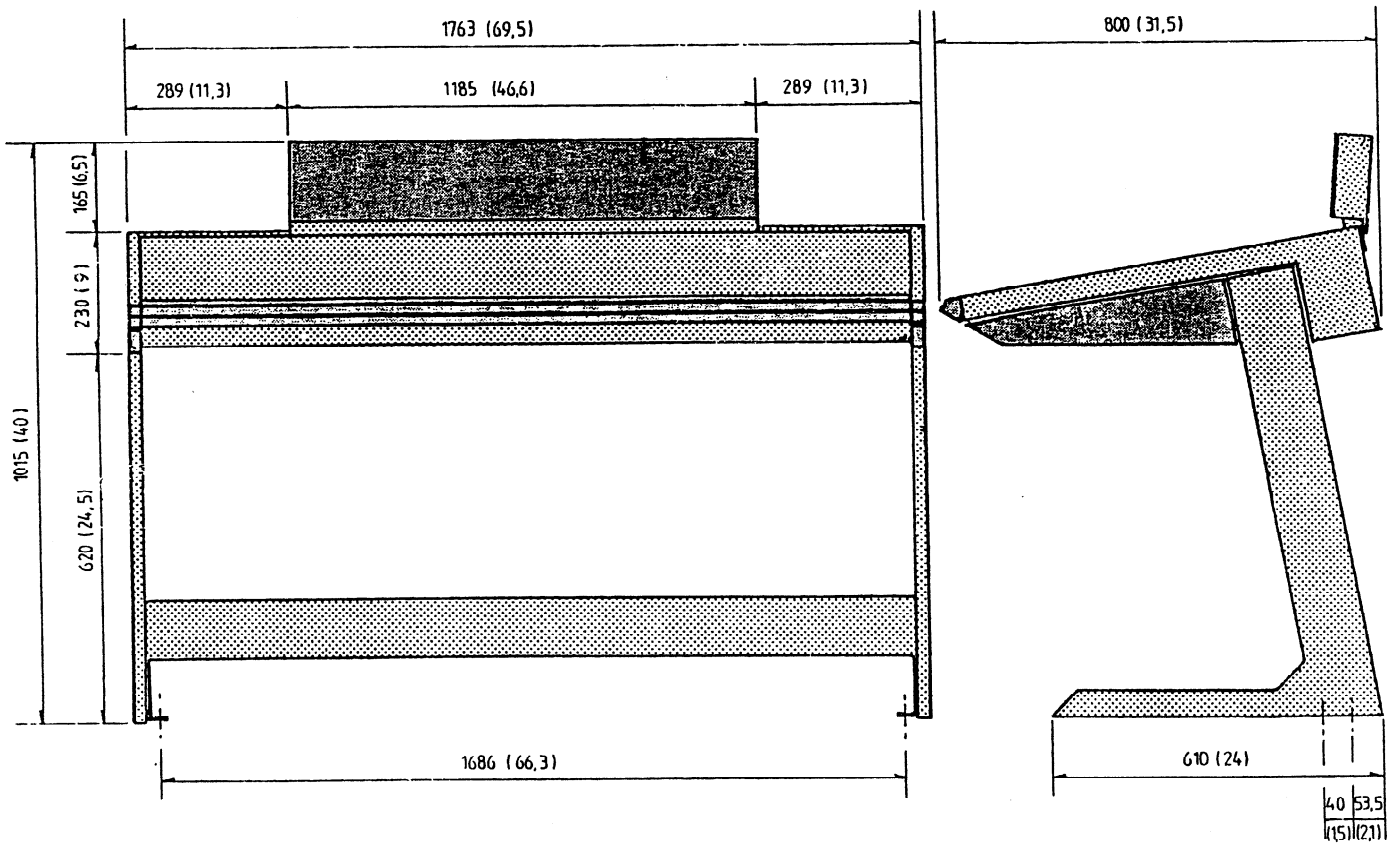

44 WAY CHASSIS

mm (inches)

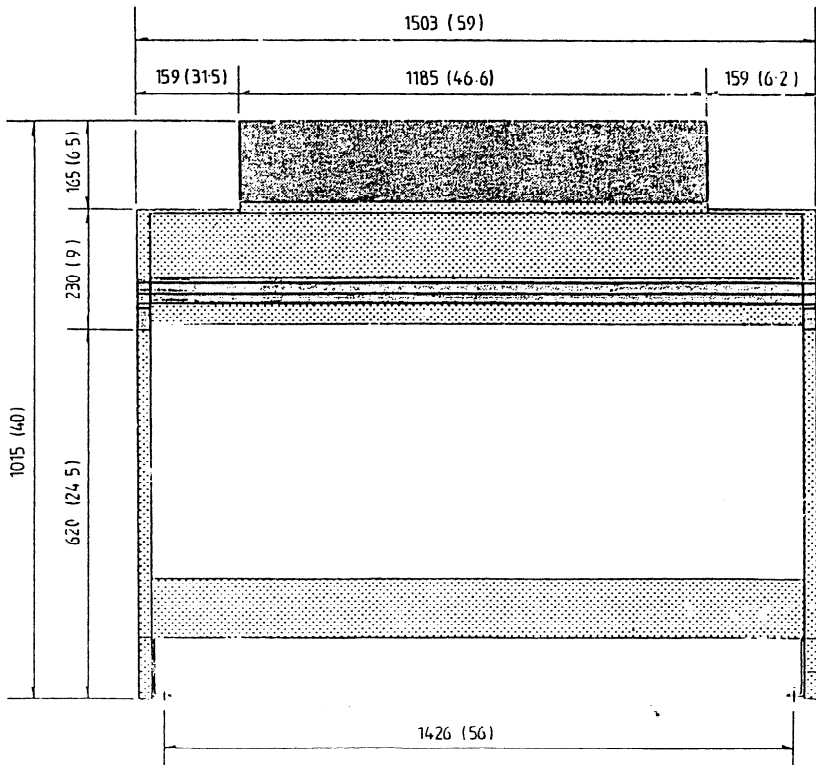

36 WAY CHASSIS

mm (inches)

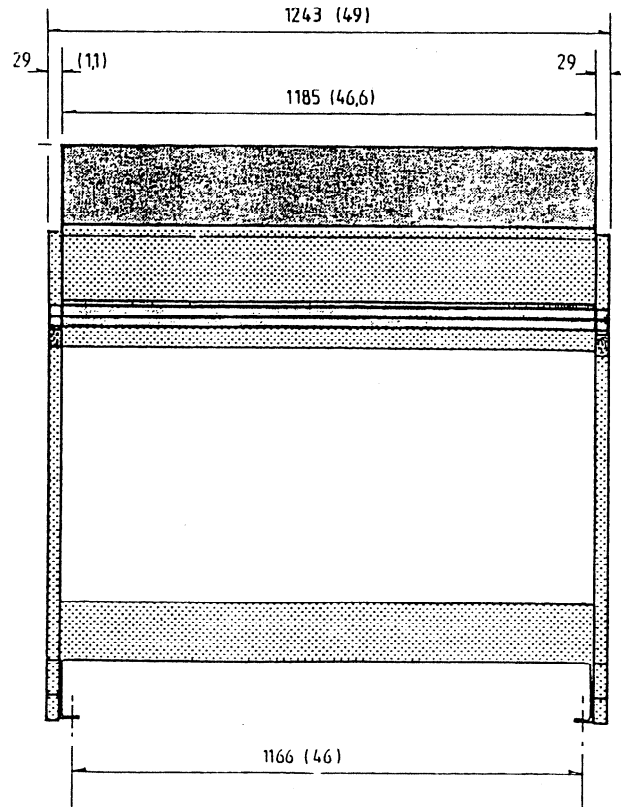

2.0 Module Exchange

Inputs

M310, M360 - all modules are identical except for the numbered mute buttons.

When ordering service exchange modules order module only (without mute button) and transfer the mute button from the faulty module to the replacement module. When undertaking this work inspect the OPTIONS available for the module and make the exchange module agree with the faulty module prior to installation. This will avoid operation problems due to optional variations.

Outputs

M320, M325, M330, M350, M355. Modules are unique in requiring the correct OUTPUT ASSIGNMENT to be set prior to installation in the console.

Service exchange modules will be shipped with no assignment or mute button.

When the module is used for service exchange it is necessary to set up the correct assignment. Refer to section "Module Assignment" and the illustrations for module options.

In the case of M350 and M355 complete modules the L,R and Aux 1-6 outputs are assigned prior to despatch.

In the case of M350 or M355 Left or Right PCB ASSEMBLIES these are NOT assigned prior to despatch.

It is necessary to undertake assignment when replacing a Left or Right pcb assembly. Refer to the component identification dwg AG0202 iss 3.

Metering

Exchange of any Output module including M350, but excluding M355, requires correct setting of the meter mode selector plug-on links. These are shown on the module pcb component overlays.

2.1 Module Addition

1) Input Modules

This is permissible up to the maximum capacity of the frame. At present (October 1988) the maximum capacity of inputs is 40 modules of type M310 and/or M360.

This assumes there are also 8 output modules M320/M325/M330 and one master module M350/M355 and a meterbridge.

The limitation on module capacity is two fold:

- i) Power supply rating
- ii) Internal DC cable rating

Allen & Heath accepts no responsibility for the consequences of attempts to increase module capacity beyond the limits of the standard main frame and power supply.

When adding input modules to a console it is necessary to make connections to the rear panel. There are two provisions.

- i) Console supplied part filled, rear connector panel included for expansion. In this case it is only necessary to remove the module blanks and install the input modules with connections to the busbar and connector panel harness included with the console.
- ii) Console supplied part filled, rear connector blank panel fitted. In this case addition of input modules also involves addition of a matching connector panel assembly. Telephone Allen & Heath for advice. The connector panel will be supplied complete and should be installed as follows:
 - a) remove the connector blank, release fixing screws internal and external.
 - b) fit connector panel. Replace fixing screws.
 - c) Connect 4 pin harnesses to main frame Mute Processor Slave pcb assemblies. Refer to illustrations 664 and MBD193.

The modules may now be installed and connected to the busbar harness and connector panel harnesses.

Input module M310 can be added in multiples of eight. The blank module will usually be fitted in place of the highest number input modules.

Eg. Saber 32:8:16 MVU with only 24 inputs will have module positions 25 to 32 inclusive filled with two four way blank panels. Unless specified at time of order connections for modules 25 to 32 will be included for expansion at a later date.

Input module M360 can be added in multiples of four. Connector panel M306 accepts connections for four modules and is accompanied by connector panel M307 which accepts connections for four standard M310 modules.

There is no wiring in the fader bay of STANDARD consoles which would limit module addition. However should fader automation be fitted this may affect later alterations.

PATCHBAY consoles are supplied prewired at all 32 input module positions. When a part filled patchbay console is supplied it will include connections for the modules omitted. These may be added at a later date by simple connection of the module to the prewired harnesses.

2) Output Modules

Standard 16x16 models already include the maximum number of output modules for the system. The 8x8 M325 PA module system and the 8x16 M320 recording module system can be expanded.

M325 expansion: within the limitations of the largest frame (52) size it is permissible to substitute group output modules for an equivalent number of input modules. This exploits the existence of output mix buses 9 to 16 which are unused in the standard PA console. Such a variation is only possible if specified at the time of order so that internal harnesses from TAPE INPUT circuits are correctly connected between M301 and M304 panels.

M320 expansion: again within the limitation of the largest frame (52) size it is permissible to substitute group output modules for an equivalent number of input modules. This exploits the existence of output mix buses 9 to 16 which are unused in the standard 8:16 format console. The result would be a format 32:16:32. There is not (October 1988) a meterbridge giving 32 track meters however.

On consoles having less than 8 output modules of any type, eg. 4 x M330 giving 8:8 format then the standard connector panel for 8 modules is supplied plus a four way module blank. Addition of the remaining modules may take place using the prewired connections to the busbars and connector panel. It would be necessary to order the additional modules pre-assigned to the correct output numbers and order the corresponding mute buttons for group monitor mutes.

ALLEN & HEATH SABER SERVICE MANUAL

All meterbridges are prewired and connected to the output connector panels for operation of 16 "track" meters and the L,R monitor pair. Refer also to section 2.3 for details of module assignment.

M330 expansion: no additional outputs are available however additional monitors 17 to 32 can be provided by fitting 8 additional M330 modules and a connector panel, which will carry the numbers 1-16 repeated.

These monitors can be operated permanently in "fader reverse" mode. There would be no group output from the module. If specified at the time of order then Tape Inputs 17-32 can be prewired in parallel with M310 Tape Inputs as per Tape Inputs 1-16 on the standard console. This additional work is chargeable.

M335 expansion: Each M335 provides two signal paths for TAPE input and LINE input to the stereo mix. There are no group outputs. The two faders are permanently in the monitor input paths to the stereo mix. Four M335 modules with connector panel M308 when added to eight M330 creates monitors for 24 track operation.

2.2 MODULE REMOVAL AND REPLACEMENT

Module Identity

Input Modules have no identity. They will take up the position related to their location in the frame. They may be replaced or interchanged without affecting their function.

Group Modules have a unique identity signified by their module numbers. IE. wherever group 3/4 may be placed in the frame, it will always be group 3/4. Therefore they cannot be interchanged or replaced without care. Groups may be internally connected to match a different module position, but this requires changing a soldered link on the PCB. Refer to module assignment.

Metering Group modules from VU and Bar Graph consoles are not interchangeable without altering pluggable jumpers on the PCB. Interchange of these modules will result in mis-operation of the metering system.

Module Preset Trimmers

M320/M330/M350 modules contain factory preset trimmers for meter calibration and output balance adjustment. Do not alter these without suitable test equipment and a copy of the service manual.

Removal

- 1) Switch off the console power supply.
- 2) Slide the write-on strip out of the left or right-hand sides of the console
- 3) Remove the module retaining screws. Most modules have three fixing screws. The patchbay has 12 fixing screws and the M350 module six fixing screws. Do not forget to remove the central screws beneath the write-on strip.
- 4) Lift the module carefully upward. To change the links described in section 2.3, it is not necessary to remove the wiring harnesses. If the module must be removed completely from the frame, unplug the wiring harnesses from the various connectors. Carefully note the orientation of the harness connectors to facilitate replacement.
- 5) Remove the module completely from the frame.

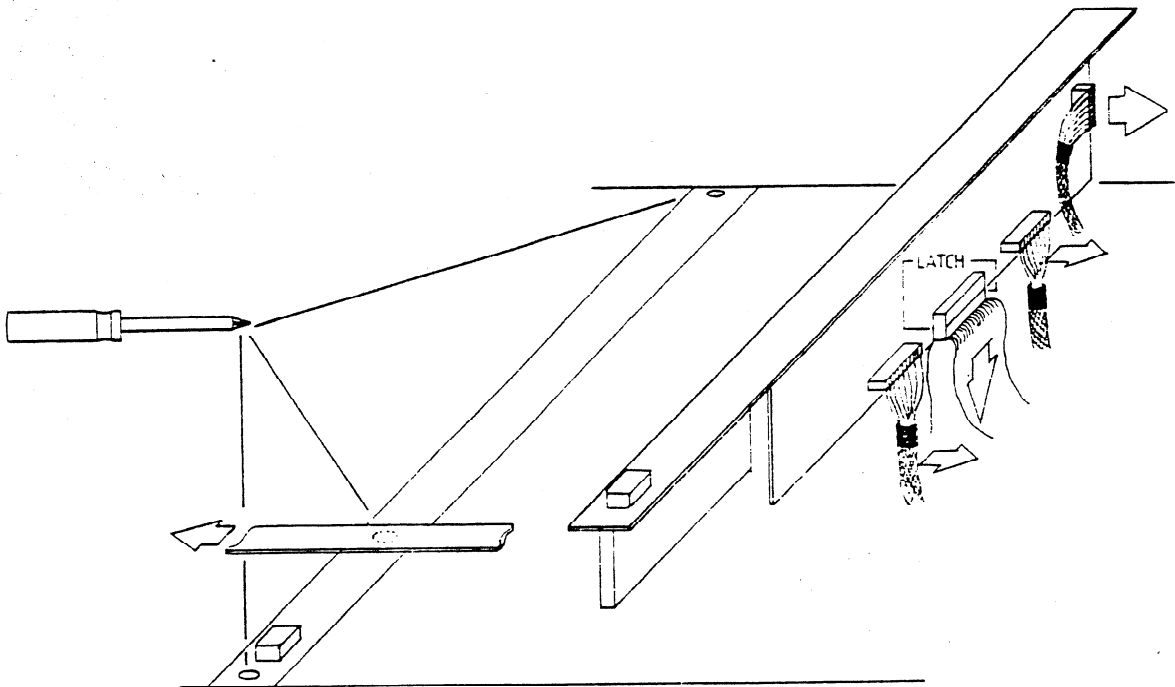
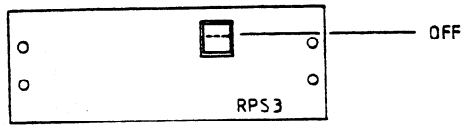

Replacement

- 1) Perform the above steps in reverse order.
- 2) Carefully dress the harness into position as the module is settled into the frame - **DO NOT FORCE.**
- 3) Replace ALL screws, problems may result from operation with the module improperly fixed into the frame.

Mute Button Removal and Replacement

The numbered mute buttons are a snap-fit on the switch shaft. They may be removed, following module removal from the frame, by applying pressure from beneath to push the button off the shaft. A replacement button is simply pushed on from above and snaps into place.

Module Fault Finding

It is permissible to fault find a module while it is connected to the frame wiring and powered up.

Take precautions to avoid accidental short circuits to the exposed connections

2.3 CUSTOMER OPTIONS

The following pages show the location and details of options for these functions:

- Auxiliary send pre/post selection
- Output high/low level selection
- Group assignment
- Monitor input high/low level selection
- Automute local/distant selection

ALLEN & HEATH SABER SERVICE MANUAL

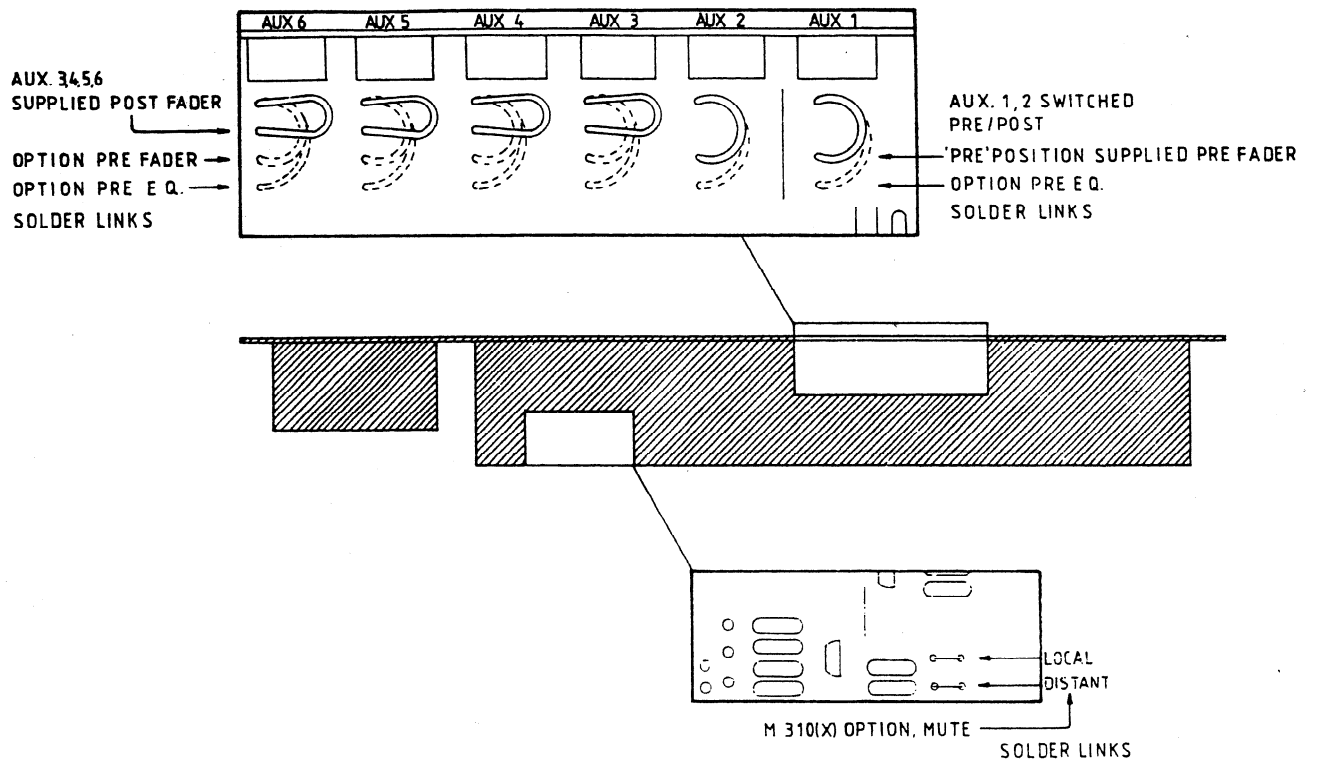

M310 MODULE PCB AG 0200

ALLEN & HEATH SABER SERVICE MANUAL

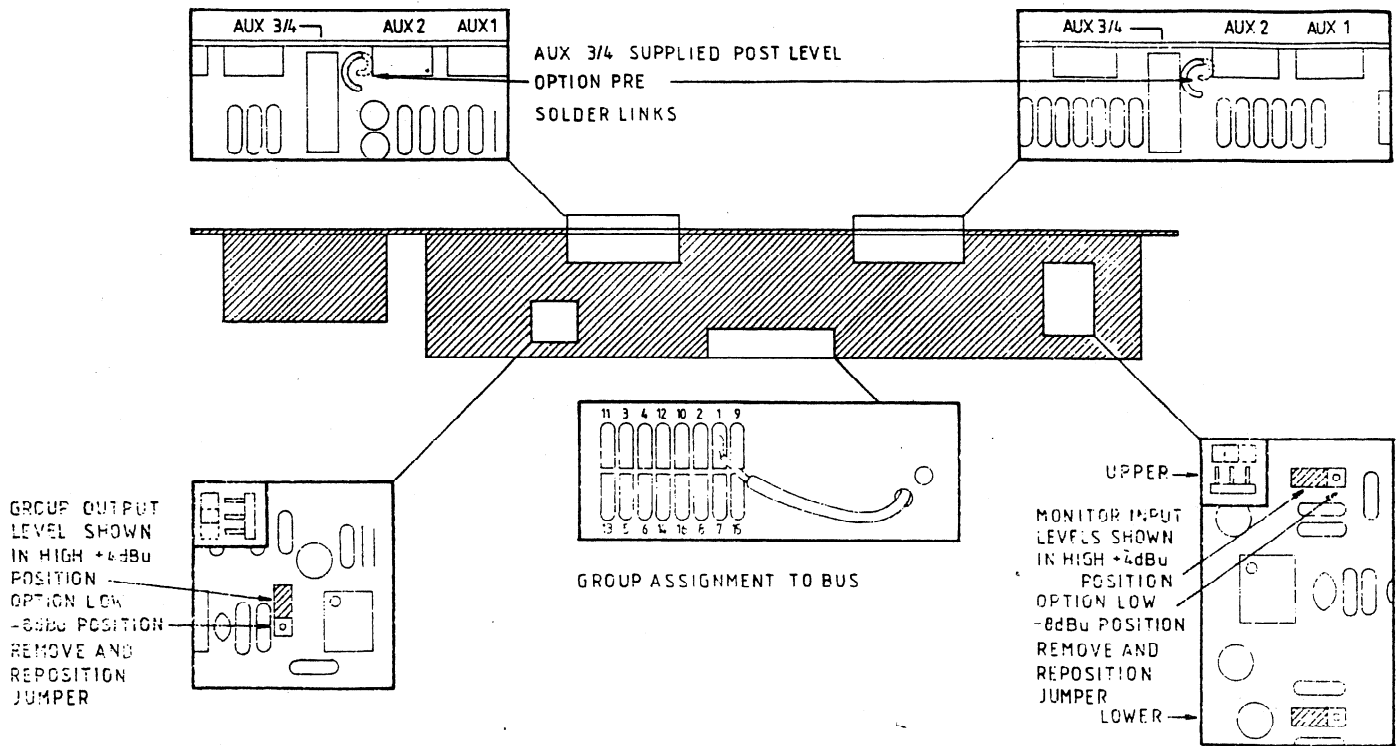

M320 MODULE PCB AG 0201

ALLEN & HEATH SABER SERVICE MANUAL

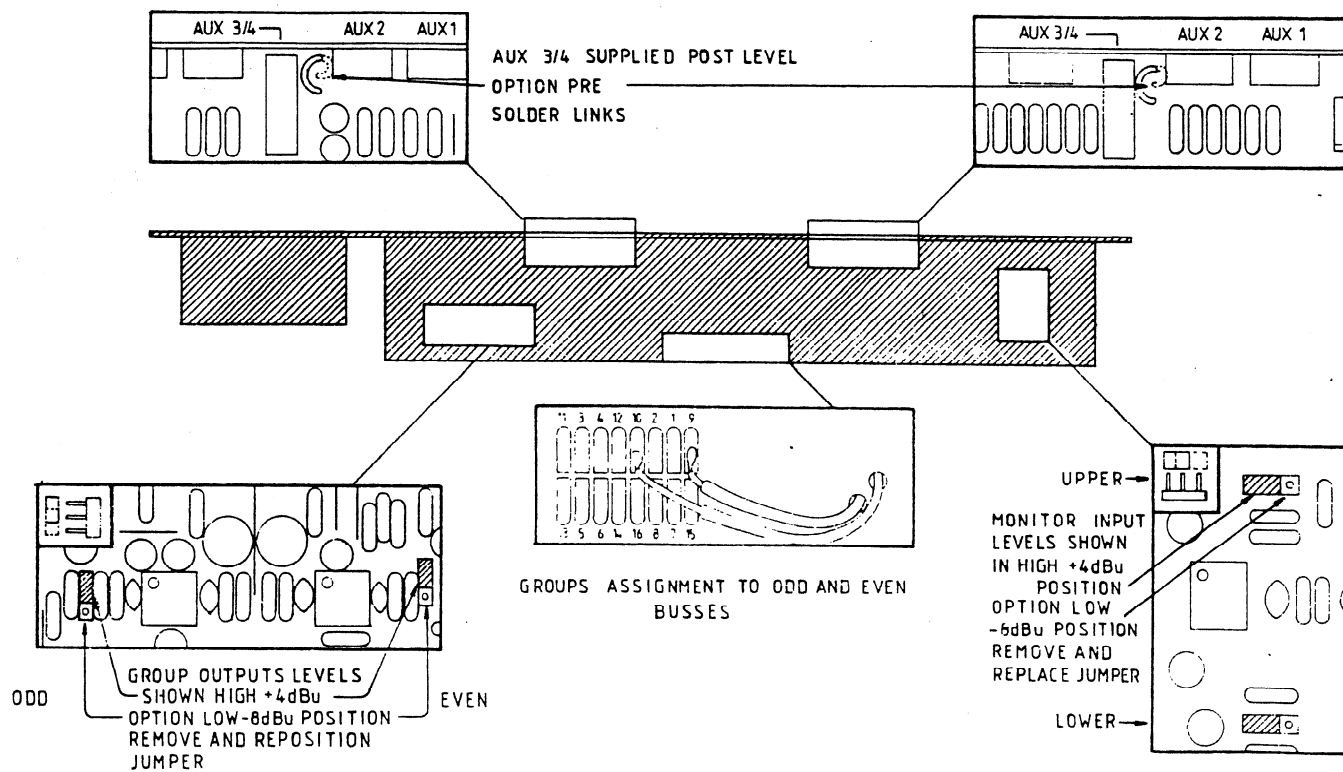

M330 MODULE PCB AG 0201

ALLEN & HEATH SABER SERVICE MANUAL

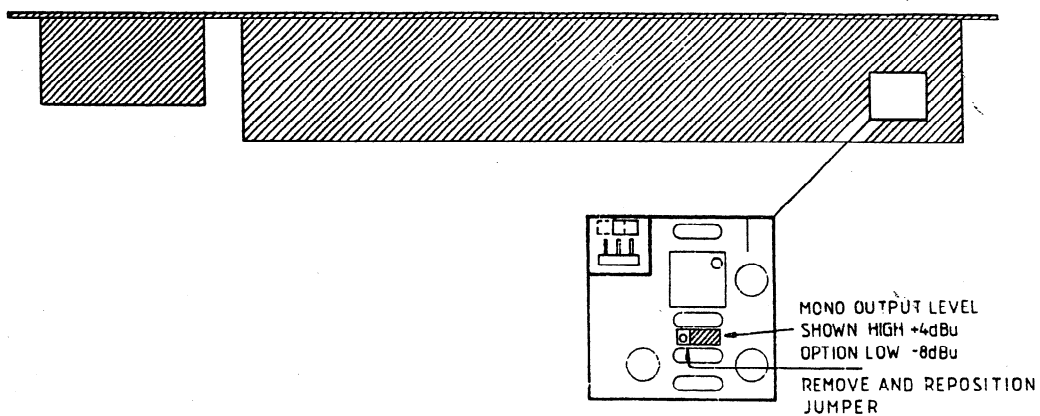

M350 MODULE (MONITOR) PCB. AG 0203

ALLEN & HEATH SABER SERVICE MANUAL

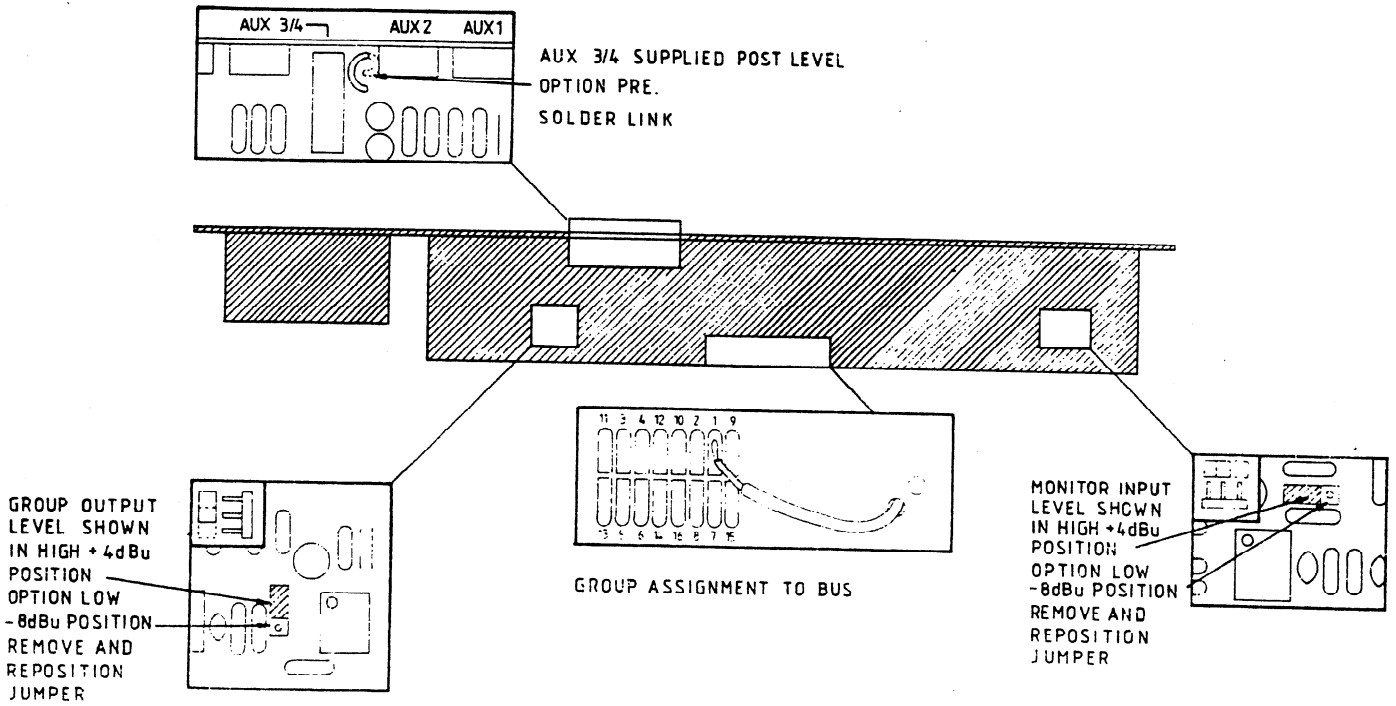

M 325 MODULE PCB. AG 0201

ALLEN & HEATH SABER SERVICE MANUAL

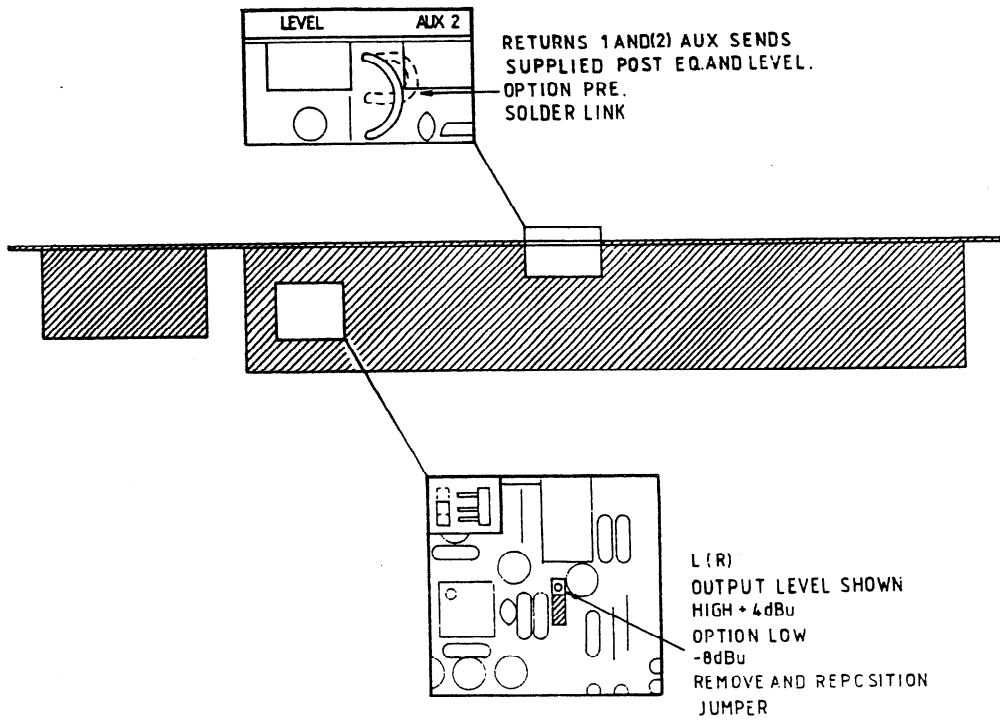

M3505 MODULE L(R) PCB. AG 0202

ALLEN & HEATH SABER SERVICE MANUAL

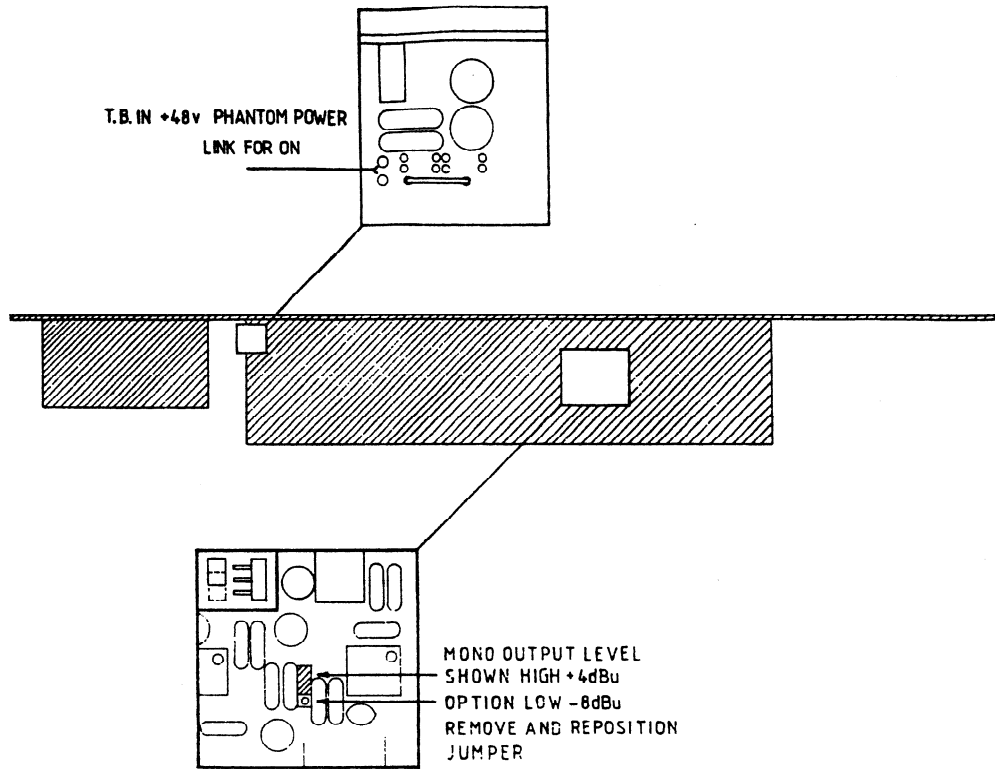

M355 MODULE (MONITOR) PCB. AG 0207

ALLEN & HEATH SABER SERVICE MANUAL

3.0 ADJUSTMENTS

1. M310(X) modules Optional functions have already been described.
There are no other adjustments relevant to this module.
2. M320 modules)
M325 modules) Optional functions have already been described.
M330 modules)

3. METER CALIBRATION

Group outputs (also multitrack meters)

Module types M320 M325 M330

Adjustment to reference level calibration may be necessary for the following reasons:

replacement of meter assembly VU or LED type
replacement of module assembly
repair of module assembly meter drive circuit

Modules and meters are calibrated in the factory in sets, each module is adjusted for the individual meter installed at the time of manufacture. Nominal calibration is 0 Vu and 0dB = +4dBu (1.23v RMS) or -8dBu (300mV, -10dBV).

LED Bargraph Meters

LED Bargraph Meters supplied with Bargraph meterbridge consoles derive their calibration from the LED MASTER PCB ASSEMBLY which is part of the meterbridge. A faulty item will introduce apparent faults or calibration errors on all LED meters. Replacement of the LED MASTER PCB ASSEMBLY should be followed by re-calibration of all meter circuits. Refer also to the CIRCUIT DESCRIPTION for METERS.

Procedure

Turn on the console oscillator and select 1kHz. Connect a 1/4" jack to XLR cable into OSC output (M302 panel). With PA consoles use an external signal generator in place of the console oscillator.

On each module (M320 M325 or M330) select TAPE monitor source. Plug the oscillator into TAPE input XLR socket for channel 1. Adjust the oscillator for output level +4dBu (1.23VRMS) or -8dBu (300mV RMS also -10dBV) if the console has been set out for low level tape machine operation.

ALLEN & HEATH SABER SERVICE MANUAL

Inspect meter 1. A reading of 0VU \pm 0.5dB is correct. If the reading falls outside this limit adjustment is necessary, see below. LED meters will indicate 0dB = first red LED ON with the test input. If the RED LED is out or the second one on, then adjustment is needed. Check by selecting 100Hz and 10kHz frequencies that the meter indication is constant with frequency.

Release the module from the console, power down to avoid accidental electrical short circuit while handling the module. Follow instructions shown earlier. Power up, with the module pcb accessible and all connections in place.

Locate the meter calibration adjusters. These are horizontal carbon trimmers located on the module PCB in the area illustrated below. Use a preset trim to adjust the meter for correct indication.

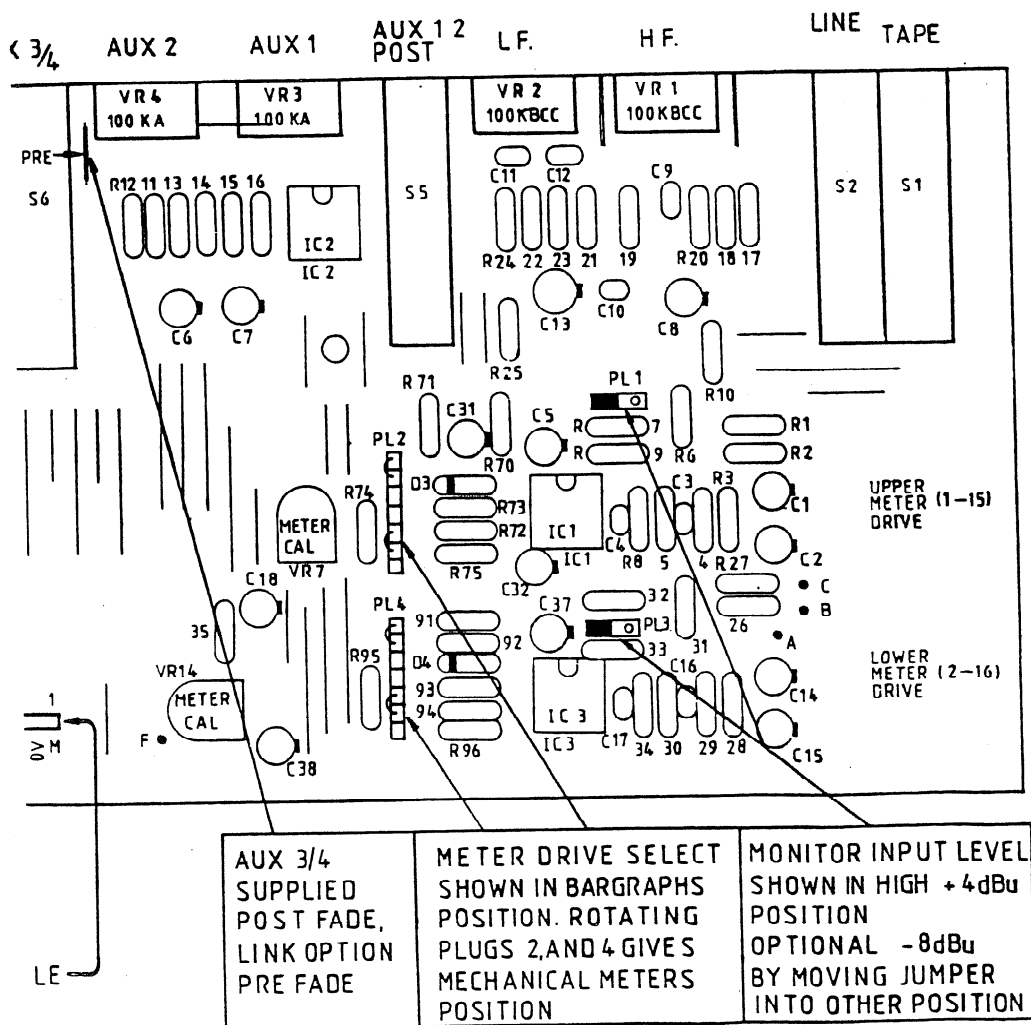

ALLEN & HEATH SABER SERVICE MANUAL

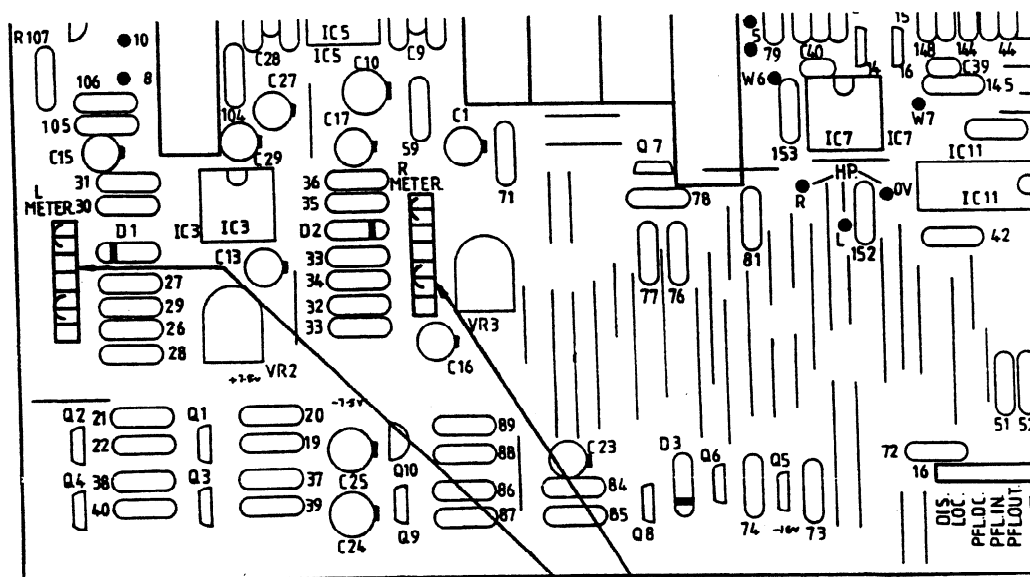

ALLEN & HEATH SABER M350
 MONITOR PCB. AG0203 ISSUE 3
 DRAWING NO. BW 330 ISS 1

METER DRIVE SELECT SHOWN
 IN BARGRAPH POSITION.
 ROTATE PLUGS TO GIVE
 MECHANICAL METERS
 POSITION.

While the module is out re-connect the oscillator to TAPE INPUT XLR channel 2 and check meter 2. If necessary adjust the corresponding module PCB trimmer.

When M320 Modules are in use test meter 1 and 9 in place of 1 and 2.

When M325 Modules are in use there is only one LED meter per module.

Repeat the test for all group modules and meters.

Alternative calibration

Bargraph meters may be recalibrated within the range of the adjusting trimmer. This range is approximately: +6dBu to 0dBu for 0dB indication

Vu meters may be recalibrated within the range -2 dBu to +12dBu for 0VU indication.

These figures apply when the +4dBu operating level is selected. When 300mv operating level is selected the figures are lowered by 12dB.

L-R Monitor

The central L - R monitor meters are adjusted using the same general procedure with the following variations.

Recording Consoles: Connect the oscillator to jack inputs PBI L and R on the M302 panel. Select source TAPE 1 and inject +4dBu. Module PCB trimmers are located on the M350 Monitor PCB.

PA Consoles: Connect the oscillator to jacks inputs EXT L and R on the M305 panel. Select source EXT and inject +4dBu. Module PCB trimmers are located on the M355 monitor PCB.

VU or LED metering

Module internal preselector. The illustration shows the location of the meter-type preselector for module types M320, M330, M350. Module M325 is always supplied set for the LED meter integral with the module, no alteration is required. Module M355 is always supplied set for use with the integral L and R VU meters.

Modules M320, M330. When interchanging modules for service purposes examine the preselector position on the original console module. Reset the preselector on the exchange module to match. The preselector has two positions: in the VU position the output to the meterbridge is rectified audio via the calibration trimmer. In the LED position the output to the meterbridge is buffered (but not rectified) audio via the calibration trimmer. Correct calibration is obtained when the calibration trimmer is loaded with the 10K ohm input impedance of the LED meter input amplifier.

Module M350 operates the same way as M320 and M330, the same preselector for VU or LED meters is required if module exchange is undertaken. The preselectors are located on the M350 monitor pcb as illustrated.

ALLEN & HEATH SABER SERVICE MANUAL

3.2 Output Symmetry

Applicable to electronic balanced outputs (EBO) which on SABER are:

GROUP OUTPUTS 1-16, "on-board" amplifier components in M320, 325, 330
 LEFT OUTPUT, plug in amplifier module "EBO" in M350, M355
 RIGHT OUTPUT, plug in amplifier module "EBO" in M350, M355
 MONO OUTPUT, plug in amplifier module "EBO" in M350, M355

During normal service adjustment should not be necessary.

To verify correct operation measure the amplitude of pin 2 and pin 3 with respect to pin 1 (chassis) of the XLR outputs. Make the measurement with 1kHz sine wave signal of approximately 0VU amplitude using an oscilloscope or precision AC volt meter. The signal present on pin 2 is the "in-phase" component. The signal on pin 3 should be of identical amplitude and opposite phase (180°). If the amplitude is too large or small adjust the internal variable preset shown on the component identification drawing "SYMMETRY" and obtain equal amplitudes. These measurements should be made "off-load", disconnect external equipment from the output in question. Refer to circuit diagram A137 issue 2 for EBO and diagram 691 for Group Outputs.

Note that Saber uses the +6dB gain variation of EBO. R1 is normally 10k ohm. For Saber and Sigma M470 applications R1 is replaced by a link.

Note

Balanced outputs are active ground compensating types. For correct operation into unbalanced loads then pin 2 or pin 3 must be connected to pin 1.

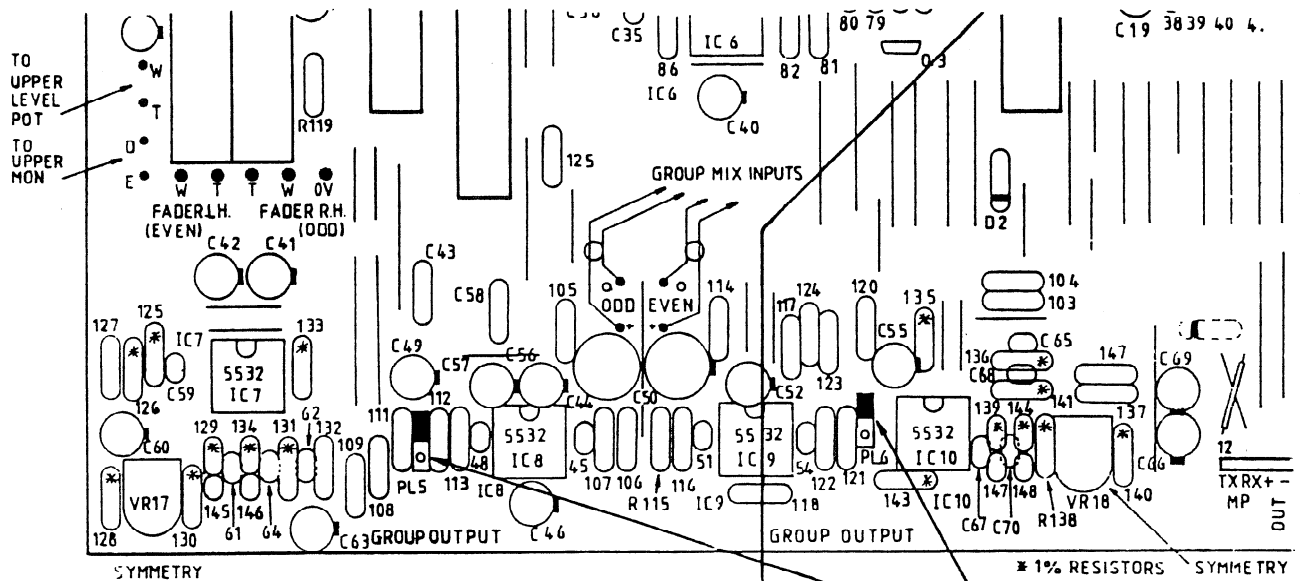

ALLEN & HEATH SABER M330
 GROUP PCB AG0201 ISSUE 3
 DRAWING NO. BW 328 ISS. 1

AUX 3/4 SUPPLIED POST FADE. LINK OPTION PRE FADE	GROUP OUTPUT LEVEL PL. 6. PL. 5. SHOWN IN HIGH +4dBu POSITION. OPTIONAL -8dBu BY MOVING JUMPER INTO OTHER POSITION
--------------------------------------------------	--------------------------------------------------------------------------------------------------------------------

3.3 Module Assignment

Module types M320, M325, M330, M350, M355

These modules provide outputs from the internal mix buses. Each output is created by a unique connection between the console common busbars (the busbar harness) and an amplifier input on a pcb assembly within a module.

Output Name	Module Type	Connection Type
Groups 1-8	M320	Solder joint selection
Groups 1-8	M325	Solder joint selection
Groups 1-16	M330	Two solder joint selections
Left	M350 left pcb	Solder joint selection
Left	M355 left pcb	Solder joint selection
Right	M350 right pcb	Solder joint selection
Right	M355 right pcb	Solder joint selection
Aux 1,3,5	M350 & M355 left pcb	Solder joint selection
Aux 2,4,6	M350 & M355 right pcb	Solder joint selection

Service exchange of any of these module types must include inspection and confirmation of correct assignment.

Refer to the module option illustrations for the location of the selections.

Note: APPARENT FAULT CONDITION: two console outputs having extremely high level output noise and low signal level. This is the result when two modules have been given the same bus assignment, eg. there are two module assigned to group bus 3. Both outputs will be noisy, 6dB low in level and sound quality will be degraded. Upon removal of one module (either one) output 3 magically cleans up.

REMEDY: Find the other module that is incorrectly assigned.

Refer also to the section:- module exchange and addition.

4.1 Outline Technical Description

1. Saber audio systems are manufactured using industry standard linear op-amp, logic gate and discrete semiconductor designs. There are no electro mechanical relay contacts in the audio signal path.
2. The console has a universal DC supply system for all amplifiers and logic and indicator subsystems. The external power supply type RPS3 operates from single phase 50/60Hz AC input and provides the three regulated DC outputs required for console operation: +16v, -16v, +48v DC. Indicator and logic systems use several combinations of +16v DC supplies. The computer system uses the +16v DC supply.
3. Audio amplifiers are supplied with +16v DC and all are centre biased types having negligible offset voltage at input and output terminals. This offset voltage is typically less than +1v with respect to chassis (0v DC).
4. Within the M350 (and M355 PA) monitor master module audio is switched by 4066 CMOS gates between op-amp stages. These gates and the associated op-amps are biased from a +7.5 DC supply which is generated locally on the pcb.
5. All pots faders and switches are isolated from the residual DC offset by coupling capacitors. Appearance of loud clicks and crackles during control operation is a fault symptom. Not however that the input preamp design includes switch contacts which are followed immediately by high gain amplification. Operation of input Tape, Line and phase reverse switches introduces a slight switch click which is not a fault.
6. Audio inputs are a mixture of balanced (differential) and unbalanced types. Input impedances are high, greater than 5k ohms.
7. Audio outputs are a mixture of balanced (active electronic type) and unbalanced types. Output impedances are low, to drive loads down to 600 ohm total (balanced outputs) or 2k ohms (unbalanced outputs).
8. All audio inputs and outputs are phase coherent except for group insertions points which are phase reversed (180°).
9. Module assemblies are tested for performance prior to final test of complete consoles.
10. Routine adjustments are not necessary to maintain operation.

4.2 Check System

There are subsections to this system as follows:

i) Check System "PFL"

Bus 28	DC control from "PFL" pushbuttons (M350 and M355 only) to PFL detector circuit.	
Buses 24 and 26	respectively ENABLE and DC buses for M310 channel modules.	
Buses 23 and 25	respectively ENABLE and DC buses for M320, M325 and M330 modules.	
Check Mode Switch, S7, master console mode selector.		
PFL detector circuit	M350 pcb AG0203	Q5, Q6, Q7
	M355 pcb AG0207	Q5, Q6
PFL audio summing amp	M350 pcb AG0203	IC5 pins 5,6,7
	M355 pcb AG0207	IC4 pins
Bus 34	audio mix bus for channel and monitor CHECK switch outputs. Connects to PFL summing amp via PFL/SOLO mode switch.	
Bus 32	audio mix bus for Aux 1-6 and Return 1-4 PFL switch outputs. Connects permanently to PFL summing amp input.	
PFL interrupt logic	M350 pcb AG0203	IC10 (IC3) 4066 CMOS gates
	Configured as changeover switches in the audio path. Either IC4 (IC2) or IC5 (IC4) outputs connected to meter driver circuits and monitor output circuits. (In brackets IC numbers for M355 monitor pcb).	
TB IN	M350 system only:- uses PFL summing amp and switching to inject an external audio source over the monitor loudspeaker circuits.	
COMMS 1 and 2	M355 system only:- same as TB IN in principle.	

The two modes of the PFL system are as follows:

Normal; PFL OFF: All check and PFL pushbutton volts are released. Buses 28, 24, 23 self bias to zero volts DC, Q6 is turned on, control point A holds IC10 gates 1/2 and 11/10 on, low resistance. Control point B holds IC10 gates 4/3 and 8/9 off, high resistance. PFL LED is off.

PFL ON: One check pushbutton selected. Buses 28, 24, 23 pulled low, Q6 is turned off, control points A and B toggle and PFL LED is turned on. IC10 gates 1/2 and 11/10 go high resistance. IC10 gates 4/3 and 8/9 go low resistance. IC5 output is connected to the meter drivers IC3 and monitor level control VR4.

Note: Changing mode from PFL to SOLO will inhibit CHECK PFL. However PFL from Aux 1-6 and RET 1-4 remains active.

ii) Check System Solo

The subsections of the SOLO system are as follows:

Buses 24 and 26 respectively enable and DC buses for M310 channel modules.

Buses 23 and 25 respectively enable and DC buses for M320, M325 and M330 modules.

Check mode switch S7 master console mode selector. In the following description assumed to be in SOLO position (pressed):

Enable switch S9 for M310 channels. When selected connects bus 24 and Q8 emitter and also illuminates the LED "chan".

Enable switch S10 for M320, M325 and M330 modules. Operates as S9 for bus 23 and LED "mon".

Q8 and R84,85 C23 form a current source for the enable buses.

Link switch S8 when selected connects together DC buses 25 and 26. LED "link" is turned on.

Check switches on modules, when selected connect together buses 24 and 26 (M310) or 23 and 25 (M320, M325, M330).

ALLEN & HEATH SABER SERVICE MANUAL

Transistor switches on modules M310 (Q10) M320, M325, M330 (Q1 and Q3) which are connected to the DC buses via the check switch. The transistor controls the module audio mute FET.

The three modes of the check solo system are as follows:

- | | |
|--------------------------|--------------------------------------------------------------------------------------------------------------------------------------------------------------------------------------------------------------------------------------------------------------------------------|
| Normal, SOLO NOT enabled | operation of a check switch connects DC and enable buses together and isolates that module from the DC bus. Enable buses are biased to the negative supply and the voltage on the DC bus does not change, module transistors therefore remain biased off and no muting occurs. |
| Normal, SOLO enabled | the enabled bus is biased negative by Q8 to approximately -11v. |
| Enable, SOLO | operation of a check switch connects DC and enable buses together and isolates that module from the DC bus. The enabled bus bias current pulls the DC bus up to approximately -12.5v and module transistor switches are turned on. Audio mutes occur on all modules NOT solo. |

4.3 Audio Mute Element

This is a common circuit element used extensively throughout Saber modules and other Allen & Heath products. The design has three important qualities:

- i) the audio switch is a special design of electronic solid state switch that employs a field effect transistor (FET), this component has practically infinite operating life and requires negligible power.
- ii) the operation of the switch is by a DC control voltage which may originate locally within the module or from a remote location such as a computer memory.
- iii) operation of the switch introduces negligible degradation to the audio signal. In particular noise, control feedthrough (click), harmonic distortion and shut off are all excellent.

The switch comprises the following sub sections:

1. An input amplifier; this op amp provides a defined impedance and level for the FET drain-source channel.
2. An FET; this n-channel junction FET is chosen for large ratio of "on-to-off" resistance, low "on" resistance, optimum pinch off voltage and low control feed through.
3. An output amplifier; this op-amp is configured so that the FET drain-source channel is at the summing mode where no voltage exists, this achieves many of the high quality performance characteristics required.
4. A DC control system; the gate of the FET must be biased negative with respect to the drain-source in order to pinch off the drain-source and mute the audio path.

The FET gate is connected by the control transistor to the console negative DC supply (audio off) or allowed to float (audio on). The transistor also provides increased flexibility in the DC control input arrangements.

The DC control system includes a method of "latching" the panel switch output to create a persistent on or off status. In the Saber application panel switches are momentary action type, the output pulse of which is converted into a steady state by the central mute processor system acting via the slave bus system.

Successful continued operation of the audio mute element relies on both the FET and the control system. The FET is operated within its maximum ratings and is a high reliability component. The circuit board area around the FET gate is at a very high impedance and should not be allowed to become contaminated with any dirt or grease which could conduct electrically.

The control voltage on the FET gate may be measured using ordinary test instruments with no risk of damage. The audio signal path includes the output amp summing mode (op-amp - input terminal). No audio signal voltage is measureable at this point or on the FET drain-source when audio is on.

When fault finding it may be helpful to force the base of the control transistor high using a temporary connection between the base and ground. This turns the transistor on and causes the FET to pinch off = audio off. Alternatively force the base low (to -ve supply) to turn audio on. The temporary connections should be made with a 1/4w resistor 1k ohm for example, as the connecting conductor.

Circuit Description: Metering

4.4 VU Metering

Moving coil VU type indicators are supplied with VU consoles and in PA console M355 modules.

The meter movement is a DC microammeter which is supplied with rectified audio programme from the console modules. The interconnecting 'phono' cable carries the rectified drive signal from the module to the meter movement. Meters are illuminated with internal 'festoon' miniature lamps which are replaceable by removal of the meter and opening the case. Lamps are soldered in place. For replacement lamps refer to the SPARE PARTS LIST. Lamps are rated at 8v DC and the lamps for two meters are connected in series to the console 15v supplies. Refer to circuit diagram 665. In normal service VU meters will give trouble free service and will not require recalibration unless module repair or exchange takes place.

4.5 LED Metering

Recording Bargraph (BG) console metering

Sets of pcb assemblies in the meterbridge provide the following functions:

Pcb Type	Function	Circuit Ref
LED master (one off)	reference scale generation, scan clock generation, address code generation, address & scale multiplex output.	MBD 189iss4
LED rectifier	audio rectification to DC, rise and fall time constant, comparison of scale with rectified audio.	MBD 189iss4
LED display	Scale demultiplex, LED display drivers.	MBD 189iss4

This pcb set receives DC supply from the console RPS3 unit via dedicated cables in the DC harness. There is no connection within the console frame and modules between audio and LED meter DC supplies. This is deliberate to avoid supply induced crosstalk and noise.

Logic ICs and LEDs draw current from the negative DC supply and zero volts.

Op-amps (TL072) and comparators (LM339) draw current from both positive and negative DC supplies.

The reference scale for the meters is created on the MASTER PCB with reference to zener diode ZD1. This scale is multiplexed with a 3 bit address code and transmitted to all rectifier and display pcb sets. The transmission rate of the scanned addresses is approximately 1000Hz. Each rectifier and display pcb set carries four channels of meter display. Each channel has its own audio rectifier and time constant components. The four outputs of the rectifier pcb pass to the display pcb and are compared with the reference scale received from the master pcb. The LED display for each channel is turned on for all LEDs "lower" than the instantaneous audio amplitude. LEDs "higher" in amplitude remain off. An equivalent current passes through transistor ZTX109 on the display pcb instead of through the LED. Refer to circuit diagrams MBD 189 issue 4.

Alternative calibration levels

Alternative calibration:	1kHz sinewave		
Vu versions:	0Vu =	-2 dBu	minimum
		+12 dBu	maximum
Bargraph versions:	0dB =	0dBu	minimum
		+6dBu	maximum

4.6 Mute Processor System:

Refer to the schematics and frame wiring diagram.

DC for the mute processor is obtained from the console +ve supply via +5v DC regulator. DC for the controller and slave pcbs is distributed on the data harness.

MUTE PROCESSOR CENTRAL COMPUTER (MPC). This is part of the SABER master connector panel assembly M302 or M305. Data is received from MIDI IN and from console module MUTE pushbuttons. The MPC is also in two way communication with the MCC control surface, part of the M350 or M355 module panel. MPC transmits data to MIDI OUT and to console module mute amplifiers. An 8 way common bus, plus extra address connections, carries address and data information from the MPC to SLAVE pcb assemblies in the frame. Each pcb has capacity to interface with 8 audio mute pushbuttons. Each has two connections; TX which is the module pushbutton logic output to the MPC, and RX which is the logic voltage from MPC to the module mute amplifier. The SLAVE pcb latches the mute status data from the MPC.

The MPC runs a program which has the following functions:

WRITE data received from MIDI IN into the working memory (console real time mute status memory)

SCAN console mute pushbuttons and MCC panel for mute or de-mute events and RECALL events

WRITE the result of each SCAN cycle into the working memory

WRITE the working memory out to module mute amplifiers

WRITE the working memory to MIDI OUT with RECALL event PATCH number

WRITE the working memory to MIDI OUT in AUTO UPDATE code format

MUTE PROCESSOR SLAVE PCB. Each pcb connects to the mute processor computer card MPC via a common bus and a unique address wire X. It also connects to each audio channel one wire connects the module switch (TX) and the second connects to the audio mute amplifier (RX). Refer to component ident BW226 and circuit diagram A164 iss2.

Operation of slave pcb:

MUTE IN 1-8 receive logic low signals from console mute switches, these are step signals from non locking switch type.

MUTE OUT 1-8 are latched open collector outputs to console audio mute amplifiers. Logic high = audio mute.

ALLEN & HEATH SABER SERVICE MANUAL

IC2 scans eight mute switches and sends data down pin 8 DI.

During power up IC2 is inhibited and "all mutes clear" data is sent to all channels via IC1.

During operation a mute switch step is detected by the computer as it scans DI. This data is written into the MP working memory and output via MIDI according to the MP mode and protocol in force. At the same time the switch status data is sent out over D0 with the appropriate address code and IC1 latch is toggled to the new switch status. Refer also to 5.5 Mute Processor fault diagnosis.

5.0 Basic console fault finding. Saber, all versions

The console normal operation can be confirmed by these quick and simple tests.

1. Power supply panel indicators for the three DC supplies (±16v, +48v) should be illuminated.
2. VU meters should be illuminated or Bargraph meters operational (use 1kHz oscillator and slate L/R).
3. On any module select pushbutton CHECK or PFL. The adjacent LED should light.

These three tests prove that DC power is being generated, is reaching the console and the modules.

If these tests cannot be passed then there may be major DC malfunction which must be repaired before attempting repair to individual sections.

Examples of possible faults:

	REASON/CHECK
1. Power supply indicators OFF	AC power off Power supply fuse blown Power supply component fault Short circuit on DC outputs
2. Meters not illuminated	Power supply OFF Meter DC connector not fitted properly All lamps faulty!
3. Module LEDs not working	Internal module edge connector missing Power supply fault Module component fault
4. No Mute Processor display (2 digit LED display)	Internal connection to MP keyboard pcb missing Keyboard pcb component fault Central mute processor fault
5. Module mute buttons do not respond	Mute Processor in "local off" mode and external MIDI equipment not echoing back MIDI to the console. Central mute processor fault
One module only, mute buttons do not respond	4 pin connector from module to MP slave pcb missing/faulty. Module pcb component fault.

It is not difficult to overlook replacement of a connector after service repair.

The tests above 1 to 5 should be made at the end of any repair work in order to check that all is well.

Service Procedure

When installed in a typical system the Saber console is a major component. A report of a console fault should always be treated seriously however, it is necessary to complete diagnosis of the fault and identify the location within the system. Only when tests have been made to eliminate faults in equipment connected to the console and in the connection cables is it appropriate to attempt repair of the console.

Use Substitution of known good circuits to aid identification of the faulty circuit.

In order of frequency of occurrence faults on installed systems can be ranked as follows:

1. External interconnections; cable termination breakdown or connection error.
2. Internal interconnections; wiring termination problem.
3. Electromechanical defect; pot switch or fader broken or worn.
4. Electronic component defect; IC transistor, capacitor, resistor defective.

Faults may be of a permanent or intermittent nature. Reports of intermittent faults demand provocation by thermal cycling, mechanical vibration and flexure as an aid to location.

5.1 DC Distribution

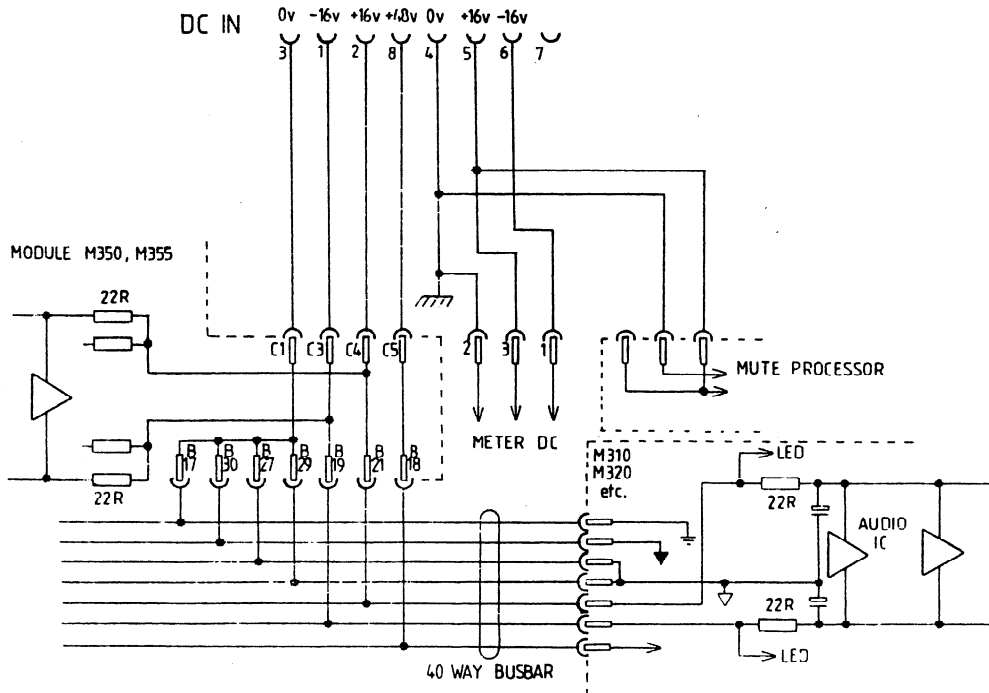

Note that the METER DC and MUTE PROCESSOR DC internal connections draw DC power from pins 4, 5 and 6 of the DC connecting cable. All other circuits of the console draw DC power via pins 1, 2, 3 and 8. Pins 3 and 4 are separate grounds.

5.2 Smoke, Fuses and Sparks or what happens when there is a short circuit somewhere

The purpose of this note is to provide useful information. The failure modes described are not unique to Allen & Heath products and may be encountered on many types of electronic equipment.

Every pcb assembly has series resistors between the local components and the main DC busbar connectors. In the event of a local short circuit these resistors pass excessive current and reach high temperature very quickly accompanied by smoke and the smell of burning paint! Usually the resistor burns out and disconnects the DC power, however while this taking place the DC voltage may be pulled low temporarily and the console malfunction. The causes of this phenomenon are:

- a) spontaneous random semiconductor IC failure, the IC also burns out and ceases to function.
- b) IC placed on the pcb 180 rotated causing reverse DC connections.
- c) Accidental short circuit +DC to ground, +DC to -DC or -DC to ground, caused by repair tool, broken wire or foreign matter,

The series resistors are 22 ohm 1/4 watt and should be replaced by an identical component.

Fuses:

The power supply includes fuse protection as follows:

- | | |
|----------------|-------------------------------------------------------------|
| AC panel fuse: | protection against short to earth and secondary failure. |
| AC pcb fuses: | protection against rectifier failure and regulator failure. |

The power supply output is protected against damage from short circuit by internal fold-back current-limit protection. Under short circuit load conditions the output voltage falls to a small value.

Accidental damage, where the +48v output is connected to other part of the PSU assembly, may cause damage to power supply components since the voltage ratings of some components will be exceeded.

In the event of power supply regulator pass-transistor failure the following symptoms could apply:

excessively bright lamps and LEDs
loud hum (due to ripple on DC) on all audio outputs
power supply running hotter than normal

Since the maximum power supply current is controlled then, depending on the particular console and its current demand, the PSU output voltage may be high normal or even low.

If such a fault is suspected take immediate action to switch off the PSU. In the event of a fail-high output voltage the console audio ICs are at risk of damage from excess supply voltage.

When repairing the PSU assembly always conclude with measurements of DC voltage, and also ripple if at all possible, for ALL outputs.

5.3 Audio and DC Measurements

1. DC Conditions, typical audio op-amp

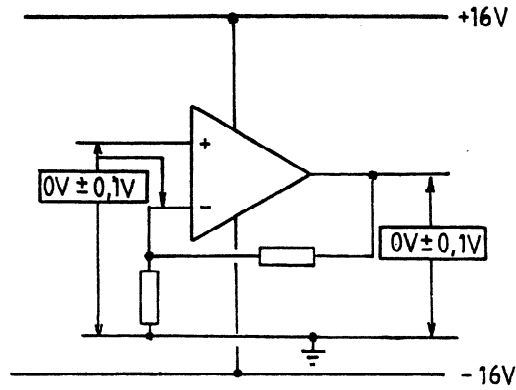

2. Audio signal measurements; typical audio op-amp, 1kHz sine wave.

Non inverting

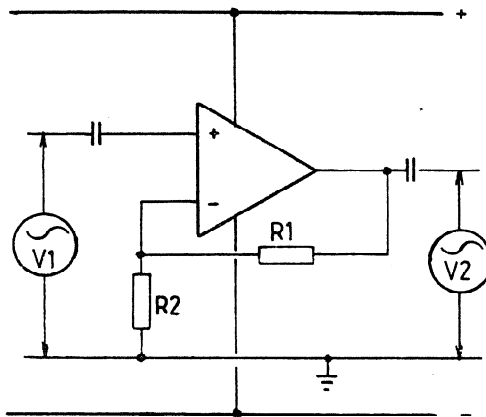

$$\text{GAIN} = \frac{V_2}{V_1} = 1 + \frac{R_1}{R_2}$$

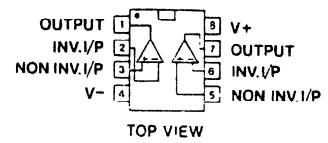

Inverting

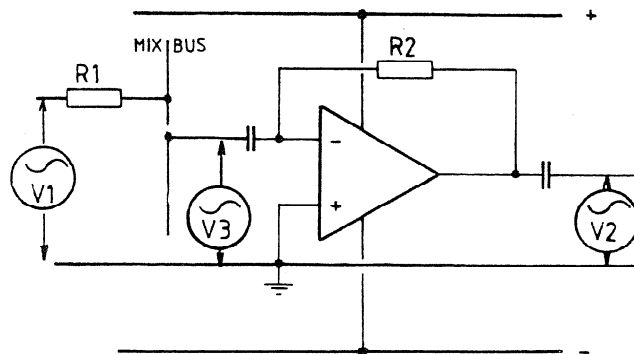

$$\text{GAIN} = \frac{V_2}{V_1} = \frac{R_2}{R_1}$$

$$V_3 \approx \frac{V_2}{10,000}$$

$$\text{VOLTAGE GAIN dB} = 20 \log \frac{V_2}{V_1}$$

5.4 LED Meter

Fault Diagnosis:

Symptom

Possible Cause

All 18 meters show same fault)
)
 Every fourth meter shows same)
 fault, eg. 3,7,R,11,15)

DC supply fault. Wrong type of meter
 selected on ALL output modules
 Master pcb connection fault
 Master pcb component fault

One meter faulty

Audio connection fault from output module
 to rectifier pcb. Wrong type of meter
 selected on output module. Rectifier pcb
 component fault. Display pcb component
 fault. Connection fault between
 rectifier and display pcbs.

Four meters faulty
 (1-4, 13-16, etc)

DC connection fault to rectifier/display
 pcb set. Busbar harness fault.
 Connection fault between rectifier and
 display pcbs.

One meter fails to indicate
 higher than a certain level

LED open circuit.

Response time of LED column
 too fast or too slow

Rectifier pcb component fault.

Mechanical assembly:

After replacing on LED pcb assembly check
 the visual alignment of the LEDs with the
 acrylic window. Obtain full scale meter
 indication and ensure the top and bottom
 LEDs are not obscured and that the LED
 column is central in the window. Perfect
 alignment may require slackening and
 adjustment of the positions of the LED
 rectifier and display pcbs.

5.5 Mute Processor Fault Diagnosis

Step 1: Confirm operation of console MIDI IN.
Select MP mode LOCAL "ON" using the SHIFT page.
Remove any connection to SABER MIDI "IN".
Test any mute switch for correct operation.
If the result is OK proceed with step 2.
If the result is no mute LED and audio switching then an internal console fault may have occurred. Refer to section xxx.

Step 2: Use the SHIFT page to turn LOCAL "OFF".
Repeat the test of any mute switch.
There should be no result, the audio and LED are "frozen" or locked in the position set before the LOCAL was switched off.
Connect SABER MIDI "OUT" to MIDI "IN".
Repeat the test of mute switches. Normal operation is expected.
If mute switches remain locked then an internal console fault may have occurred. Failure of the MIDI IN opto coupler IC is more likely to occur than failure of the MIDI OUT gate IC.
Test the MIDI IN opto coupler by measuring forward and reverse bias resistance of the opto coupler LED.

Test MIDI OUT by connecting pin 4 to pin 5.
Connect an oscilloscope to display the signal on the two pins 4 and 5 with respect to 0v (pin 2).
MIDI data is logic square wave pulse trains with peak to peak amplitude approx 2v and a switching rate of approx 30kHz.

Battery back up of the memory contents relies upon the on-board Ni-Cad cell. This is recharged while the console is powered. Failure of the cell would result in loss of memory contents following power down. On power up the memory contents would be random.

Service replacement of the cell requires removal of the Mute Processor computer pcb from the M302 (PA M305) rear connector panel.

ALLEN & HEATH SABER SERVICE MANUAL

6.0 Schematics and circuit diagrams

Title	Dwg No	Issue No
Allen & Heath Component references		
Power supply RPS3 connection details	679	2
RPS3 pcb component identification	BW222	1
RPS3 regulator pcb circuit diagram	694	1
Saber mainframe wiring diagram	664	1
Saber meterbridge wiring diagram	665	1
LED meter circuit diagram	MBD189	4
LED master pcb component identification	BW223	1
LED display pcb component identification	BW223	1
LED rectifier pcb component identification	BW223	1
Mute processor computer pcb component identification	BW224	1
Mute processor computer pcb circuit diagram	MBD190	2
Mute processor keyboard pcb component identification	BW225	1
Mute processor keyboard pcb circuit diagram	698	1
Mute processor slave pcb component identification	BW226	1
Mute processor slave pcb circuit diagram	A164	2
Mute processor wiring	663	1
Input module M310(X) component identification	BW323	1
Input module M310(X) circuit diagram	667	1
Input module M360 component identification	BW324	1
Input module M360 circuit diagram	668	1
Output module M320 component identification	BW325	1
Output module M320 circuit diagram	669	1
Output module M325 component identification	BW326	1
Output module M325 circuit diagram	686	1
Output module M325 meter component identification	BW327	1
Output module M325 meter circuit diagram	666	1
Output module M330 component identification	BW328	1
Output module M330 circuit diagram	687	1
Monitor master module M350 L/R component identification	BW329	1
Monitor master module M350 L/R circuit diagram	688	1
Monitor master module M350 monitor component identification	BW330	1
Monitor master module M350 monitor circuit diagram	689	1
Monitor master module M355 L/R, refer to M350		
Monitor master module M355 monitor component reference	BW331	1
Monitor master module M355 monitor circuit diagram	690	1
Balanced output detail for M320, M325, M330	691	1
Balanced output circuit, EBO, for M350, M355	A137	2
E.B.O. Component identification	BW192	2
M360 RIAA module component identification	MBD111	1
M360 RIAA module circuit diagram	MBD111	1
Patchbay M390 assembly diagram	702	1
Patchbay M390 pcb assembly drawing	703	1
Patchbay M390 pcb circuit types 1 and 2	681	1
Patchbay M390 pcb circuit type 3	682	2
Patchbay M390 pcb circuit type 4	684	1
Patchbay M390 pcb circuit type 5	683	1

NOTE: Module M335 is a derivative of M330. For service purposes refer to M330 details.

Allen&Heath Component References

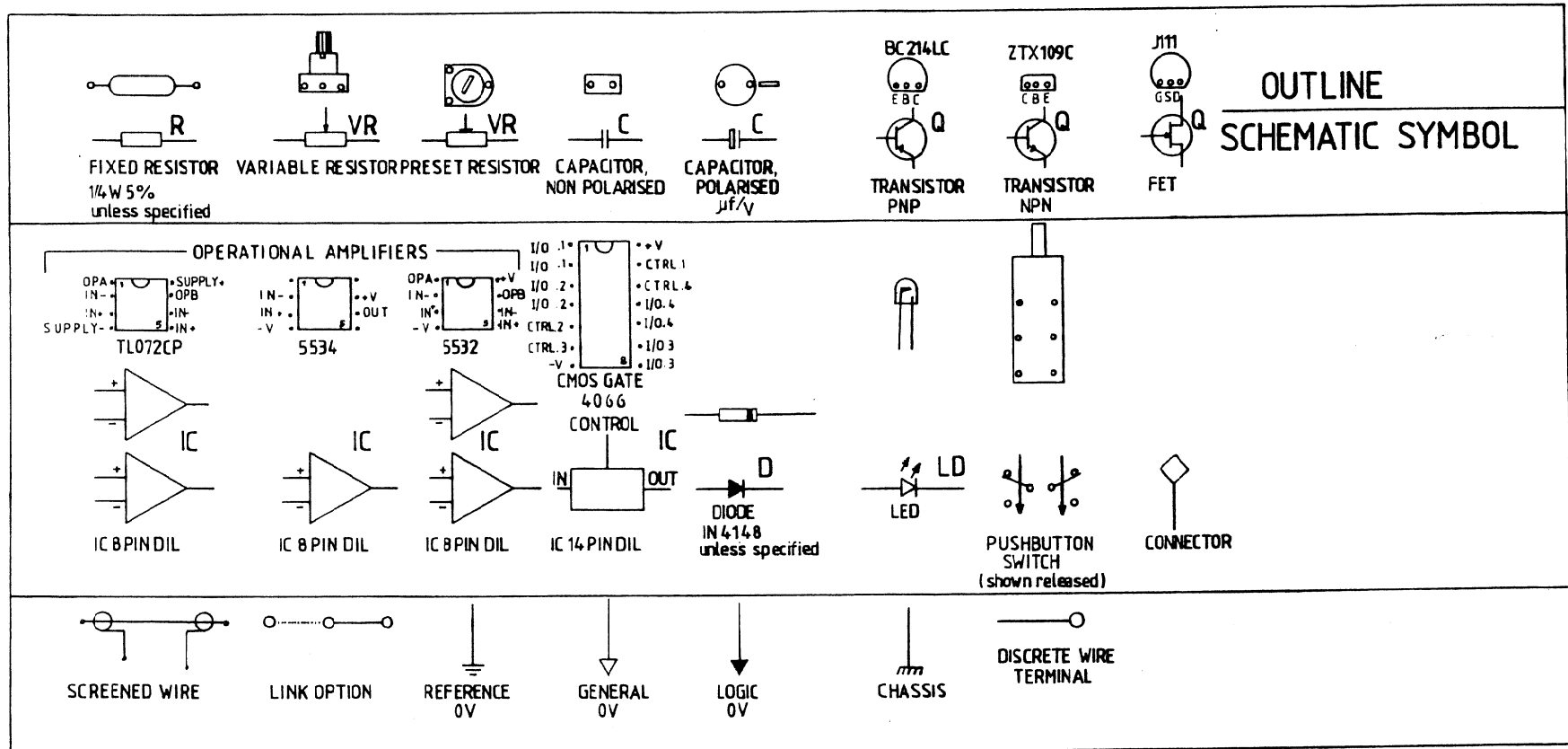

PLAN VIEW

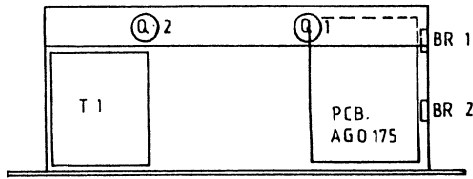

T1 225 VA AHB. DWG NO.A153 P3204/2

BR 1,2 8A 200V_{RRM} KBPC 802

Q 1,2 10A 80V T03 MJ3001

AC. FUSE 110-120v 1.25" 3AT.
220-240v 20mm 1AT.

F 1 SECONDARY AC. 20mm 0.5AT.

F 2,3 SECONDARY AC. 20mm 4AT.

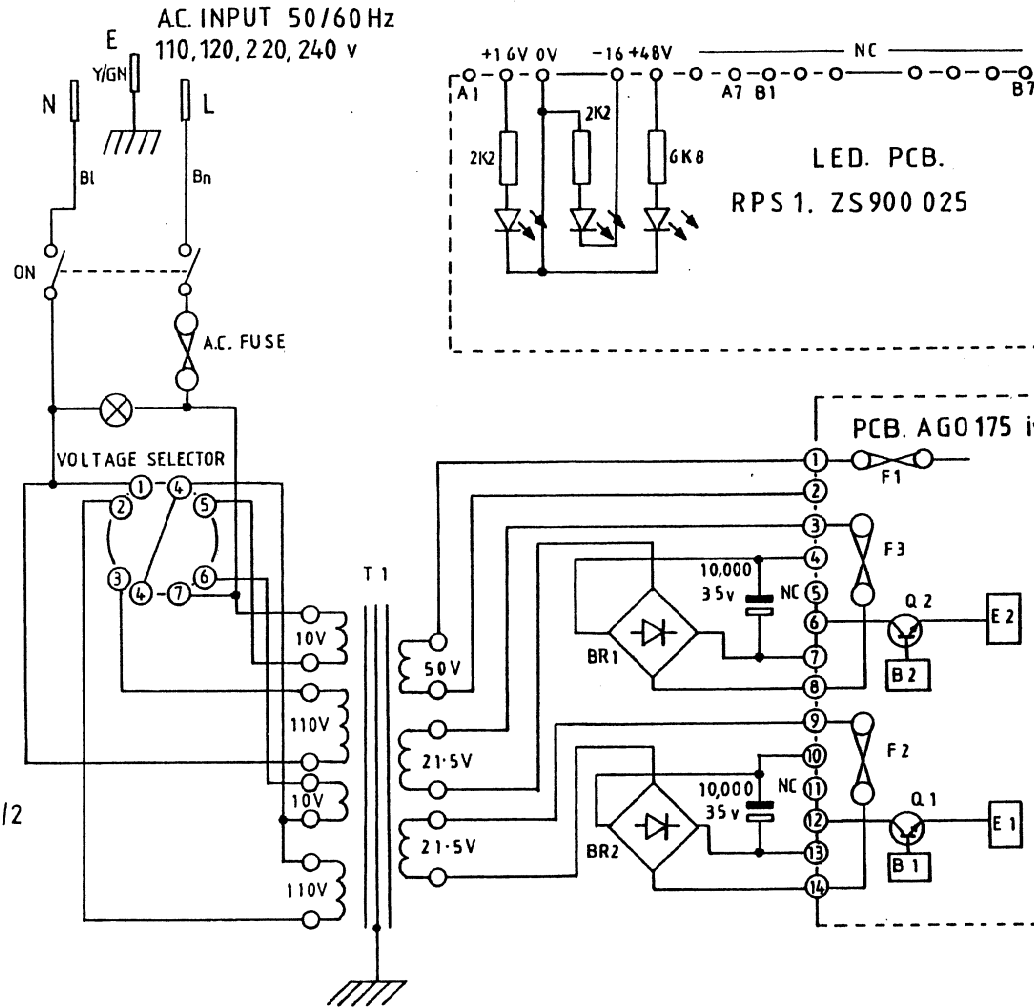

PRODUCTION	7/88
REVISION	
DATE	CH/ED

STANDARD NOTES	
ALL DIMENSIONS IN mm	
DO NOT SCALE DRAWING	
THIRD ANGLE PROJECTION	
REMOVE ALL BURRS & SHARP EDGES	
SCALE	

MATERIAL	TOLERANCES
	GENERAL ± 0.25 mm
	HOLE CENTRES ± 0.15 mm
	HOLE SIZES ± 0.10 mm
UNLESS STATED OTHERWISE	

FINISH	NOTES

UNIT TITLE	ALLEN & HEATH RPS3
DRAWING TITLE	CONNECTION DETAIL

DESIGN DEPT	DESIGNER	DATE
FACTORY	MANUFACTURE	ISSUE
DRAWING NO.	679	2

AHB ALLEN & HEATH BREMELL LTD
PROFESSIONAL AND SHIPMENT MANUFACTURERS
100175 0000
FACTORY REPAIRS DEPARTMENT, ST. PENELOPE COLLEGE, 100175 0000
DRAWING NO. 679 ISSUE 2
ARTWORKER PDS 080451

- 1 PINK
- 2 PINK ~ 50V
- 3 BROWN 2
- 4 GREY 1
- 5 N.C. +
- 6 RED C
- 7 MAUVE C
- 8 BROWN 2
- 9 ORANGE 2
- 10 BLACK 1
- 11 N.C. +
- 12 RED C
- 13 RED C
- 14 ORANGE ~

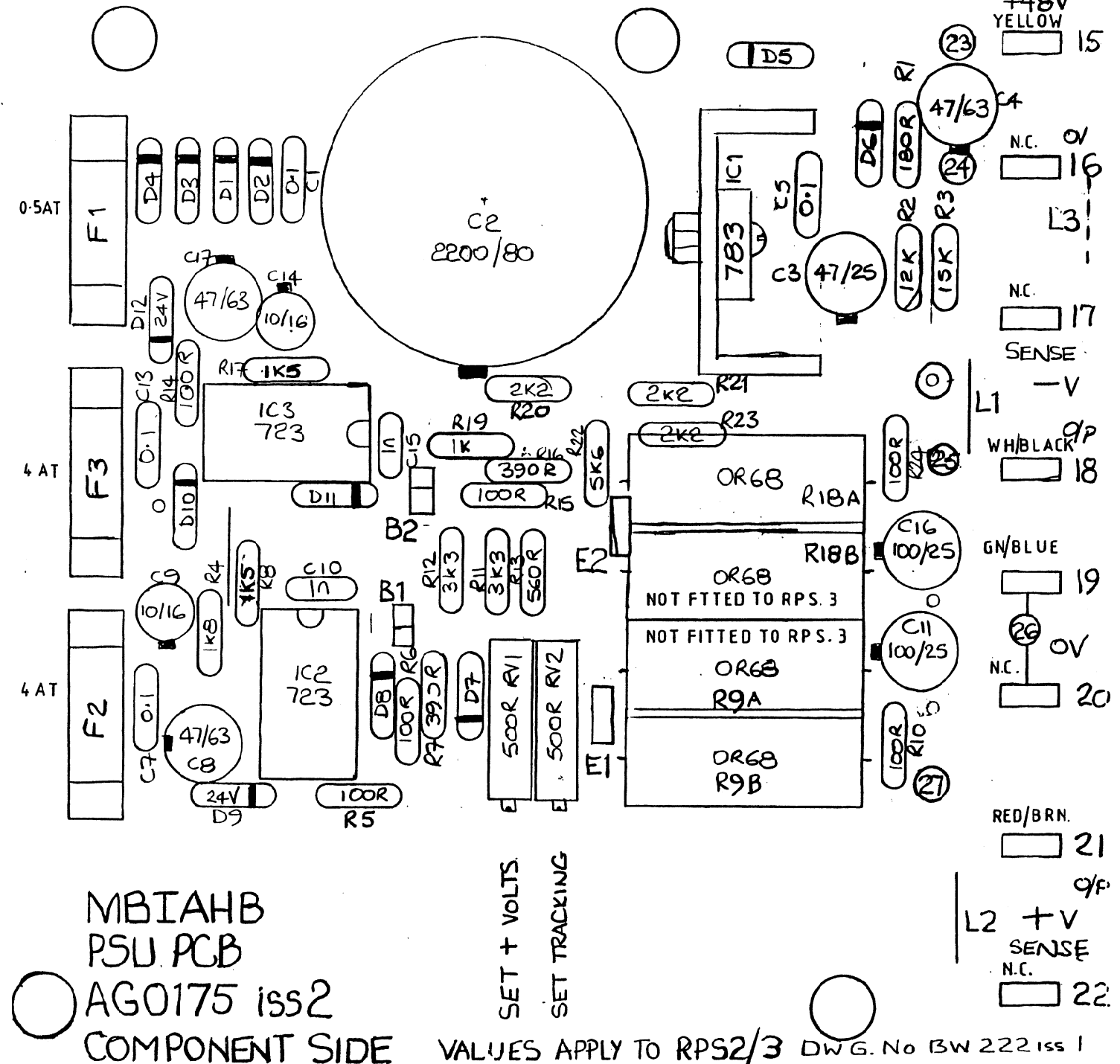

MBIAHB
PSU PCB
AG0175 iss2

COMPONENT SIDE

SET + VOLTS.
SET TRACKING

VALUES APPLY TO RPS2/3 DWG. No 13W 222 iss 1

ON DIMENSIONS

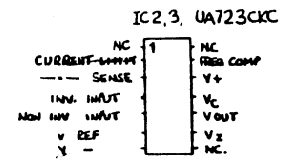
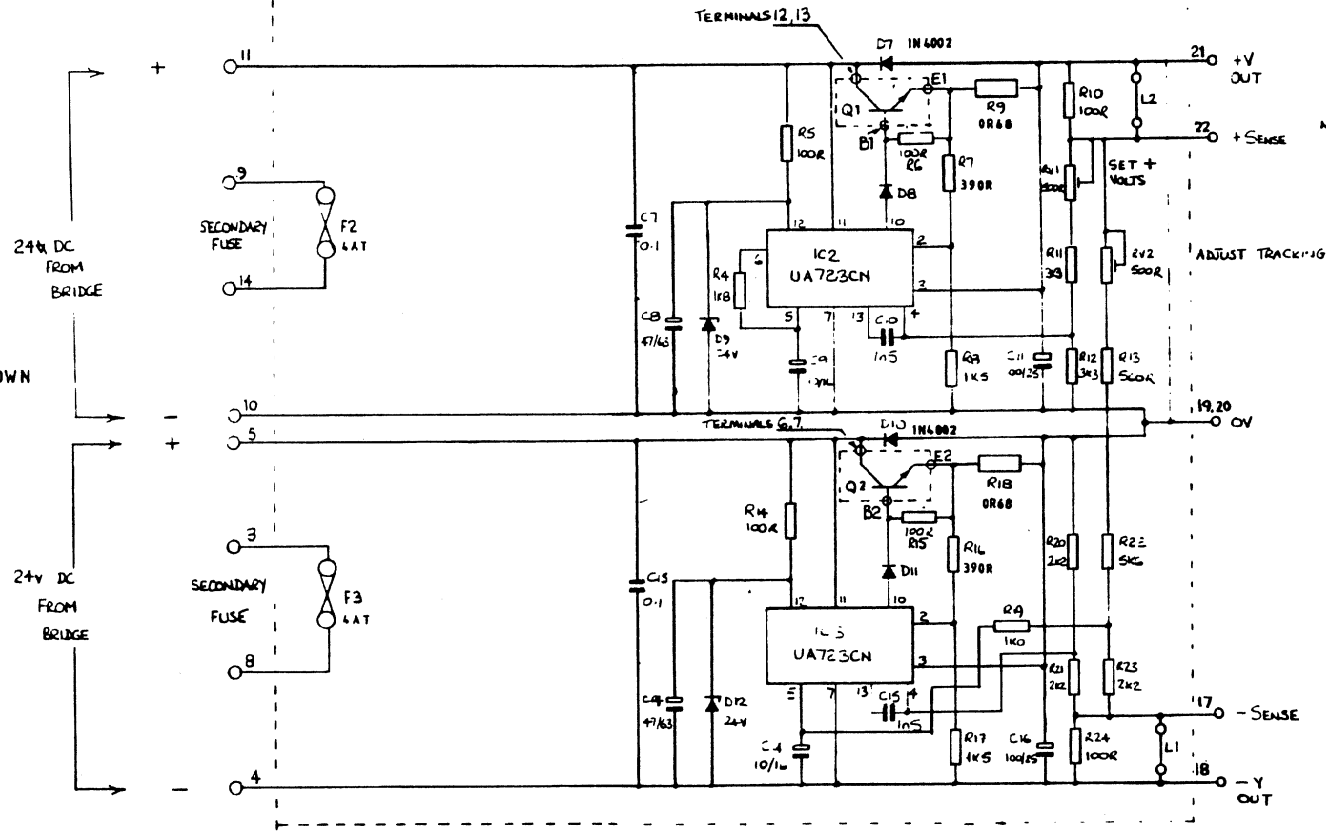
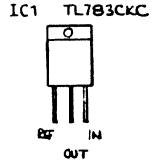
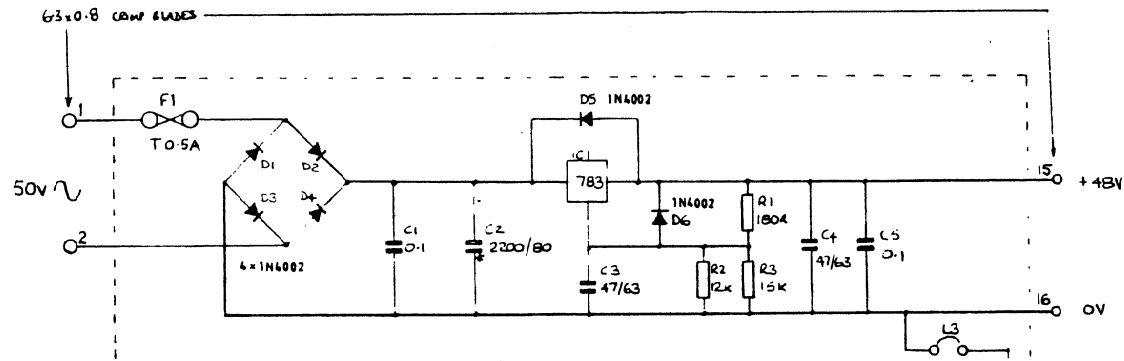

AC INPUT SHOWN ON DRAWING 679

24V DC FROM BRIDGE

24V DC FROM BRIDGE

OUTPUT CURRENT	3A
CURRENT (CIRCUIT CURRENT) LIMIT	1A
D 8, 11	LINK
Q1, 2	HJ3001

STANDARD NOTES ALL DIMENSIONS IN MM DO NOT SCALE DRAWING THIRD ANGLE PROJECTION REMOVE ALL BLURBS & SHARP EDGES	MATERIAL	TOLERANCES GENERAL ±0.25 mm HOLE CENTRES ±0.15 mm HOLE SIZES ±0.10 mm	FINISH	NOTES	ALLEN & HEATH RPS3 PSU PCB AG0175 ISS 2 CCT. DIAGRAM	<p>ALLEN & HEATH INDUSTRIAL LTD PROFESSIONAL AND CUSTOMER PRODUCTS DESIGN DEPT. 80, BAY STREET, BRISTOL ON 16 FACTORY: HENRIETTA INDUSTRIAL, ONE FERRIS, BRISTOL, G1 5 2JH DRAWING No. 694</p>
SCALE		UNLESS STATED OTHERWISE				Issue 1

POWER SUPPLY
RPS 3
DRAWING 679

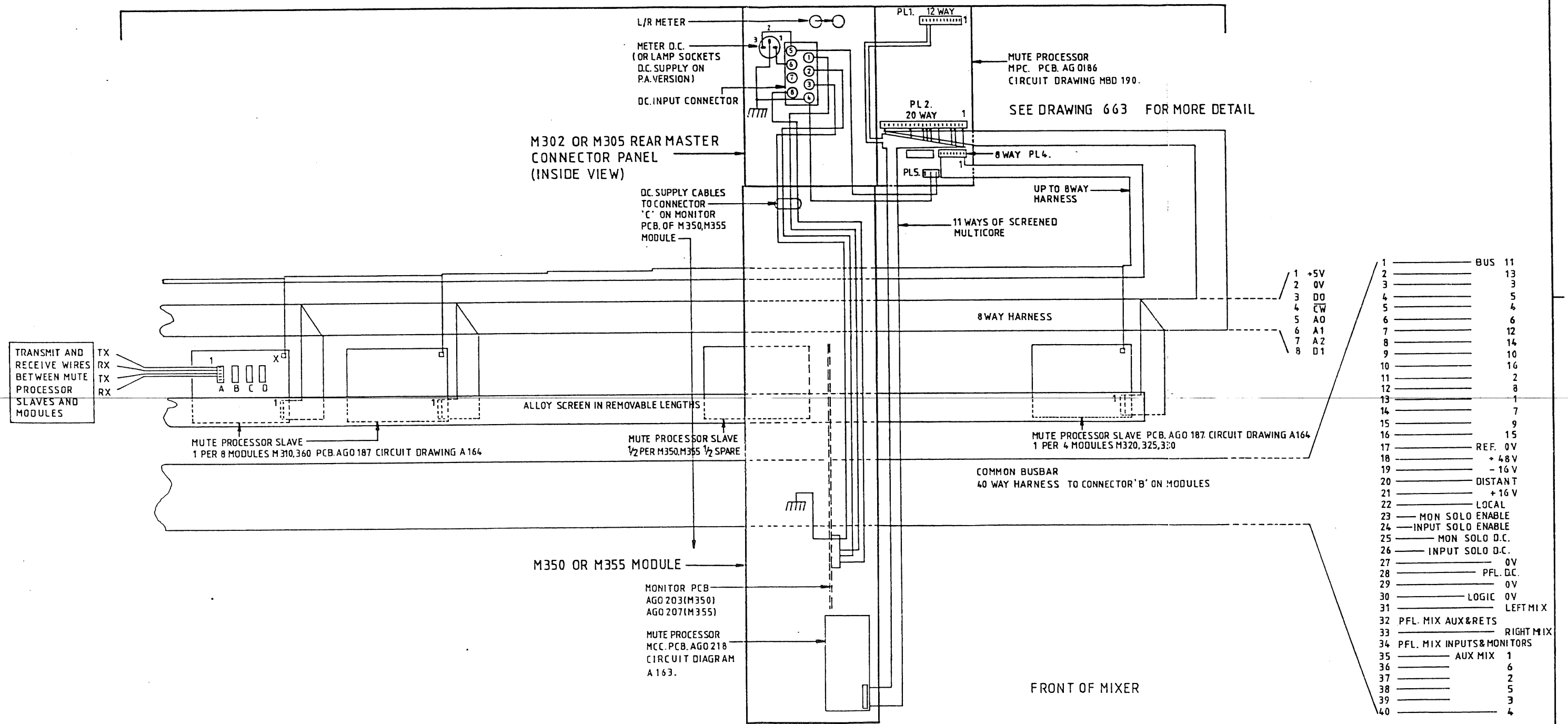
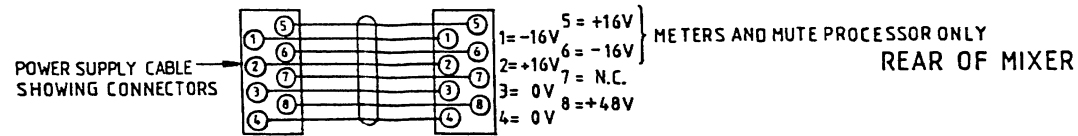
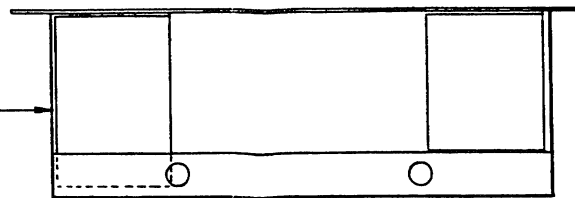

1	+5V	11
2	0V	13
3	0V	3
4	0V	5
5	0V	4
6	0V	6
7	0V	12
8	0V	14
9	0V	10
10	0V	16
11	0V	2
12	0V	8
13	0V	1
14	0V	7
15	0V	9
16	0V	15
17	REF. 0V	
18	+48V	
19	-16V	
20	DISTANT	
21	+16V	
22	LOCAL	
23	MON SOLO ENABLE	
24	INPUT SOLO ENABLE	
25	MON SOLO D.C.	
26	INPUT SOLO D.C.	
27	0V	
28	PFL. D.C.	
29	0V	
30	LOGIC 0V	
31	LEFT MIX	
32	PFL. MIX AUX&RETS	
33	RIGHT MIX	
34	PFL. MIX INPUTS&MONITORS	
35	AUX MIX 1	
36	6	
37	2	
38	5	
39	3	
40	4	

STANDARD NOTES ALL DIMENSIONS IN mm DO NOT SCALE DRAWING THIRD ANGLE PROJECTION REMOVE ALL BURRS & SHARP EDGES SCALE UNLESS STATED OTHERWISE	MATERIAL	TOLERANCES GENERAL ±0.25 mm HOLE CENTRES ±0.15 mm HOLE SIZES ±0.10 mm	FINISH	NOTES SEE DRAWING 663 AND DRAWING 693	UNIT TITLE SABER SYSTEM	AHB ALLEN & HEATH BRENNELL LTD. PROFESSIONAL AUDIO EQUIPMENT MANUFACTURERS DESIGN DEPT. 89, SHIP STREET, BRIGHTON BN1 1AE Tel: 01273 24028 FACTORY: KENWICK INDUSTRIAL EST. PENRYN CORNWALL Tel: 01326 72070
					DRAWING TITLE FRAME WIRING	
E. J. DRAWN	10.8.81 DATE CHECKED					

BARGRAPH METER POD, REAR VIEW, COVER REMOVED

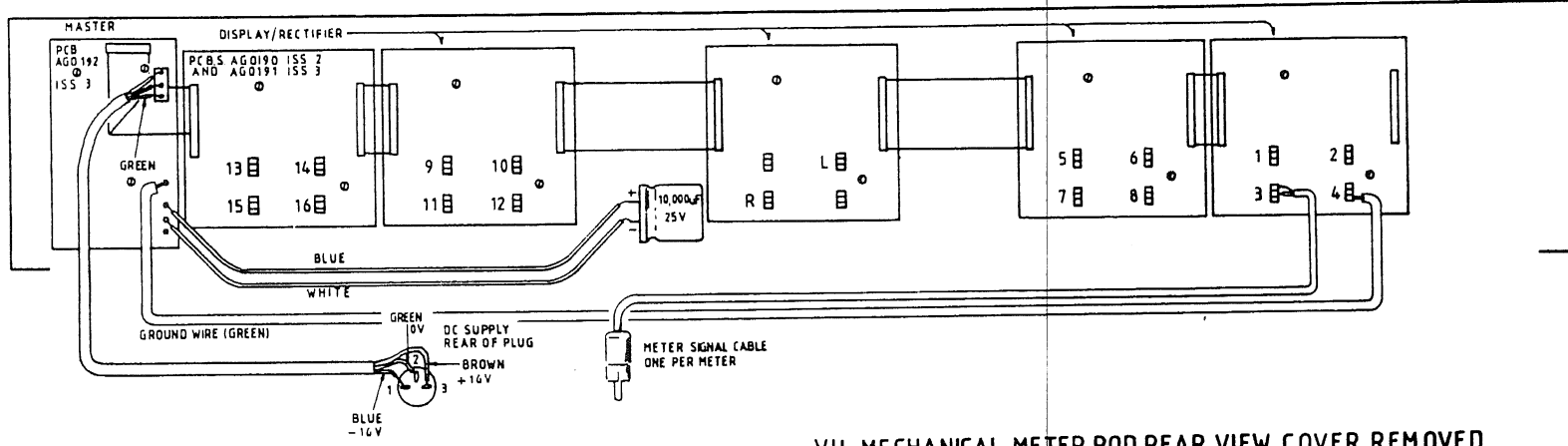

VU. MECHANICAL METER POD, REAR VIEW, COVER REMOVED

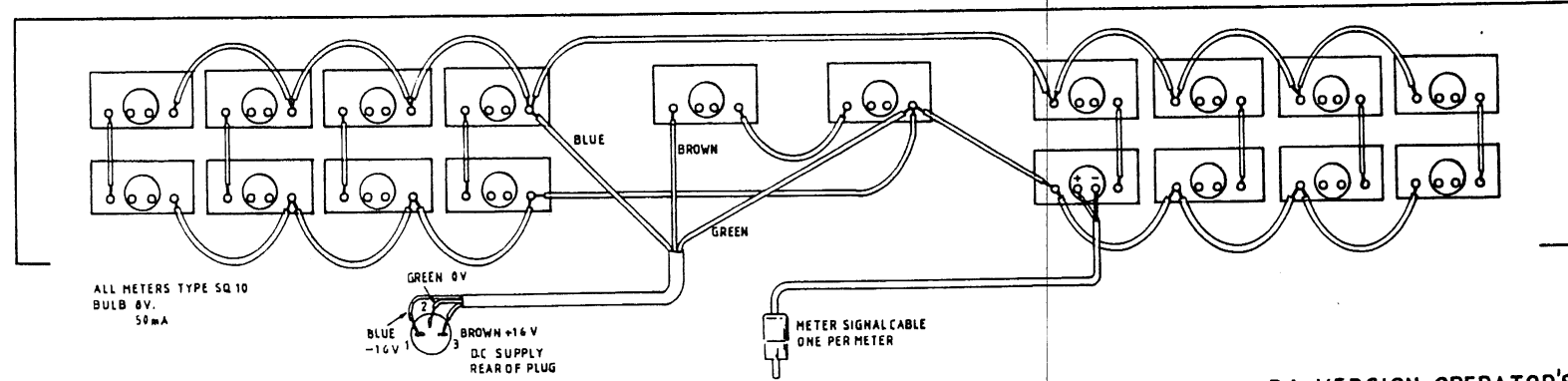

P.A. VERSION OPERATOR'S LAMP WIRING

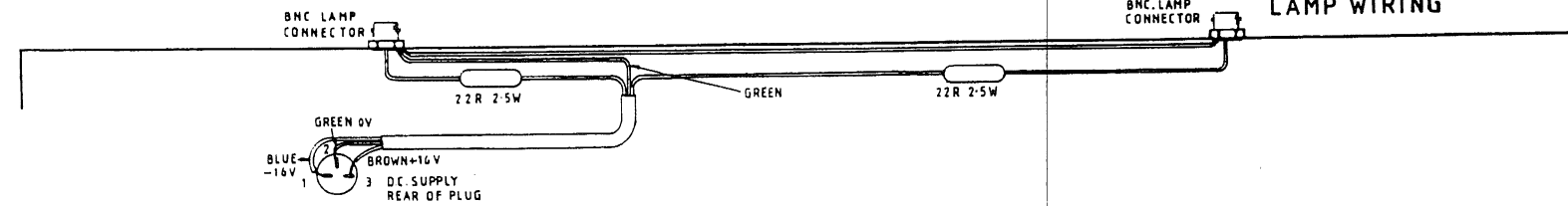

DESIGN	REVISION	DATE	CHECKED
E J		1088	

STANDARD NOTES
 ALL DIMENSIONS IN mm
 DO NOT SCALE DRAWING
 THIRD ANGLE PROJECTION
 REMOVE ALL BURRS & SHARP EDGES

SCALE

MATERIAL

TOLERANCES
 GENERAL ±0.25 mm
 HOLE CENTRES ±0.15 mm
 HOLE SIZES ±0.10 mm

UNLESS STATED OTHERWISE

FINISH

NOTES

UNIT TITLE
 ALLEN & HEATH SABER

DRAWING TITLE
 METERPOD WIRING AND
 P.A. LAMP WIRING

AHB ALLEN & HEATH SABER LTD
 PROFESSIONAL AUDIO EQUIPMENT
 MANUFACTURERS

40 BURN HAY, 40 BURN HAY, BRISTOL, GLOS, ENGLAND BS20 7JH
 FACTORY: HENNING ROAD, 1ST FLOOR, CROMFORD, LEICESTERShire LE10 2JH

DRAWING No. 665 Rev. 1

ARTWORKER: PGB 05/84

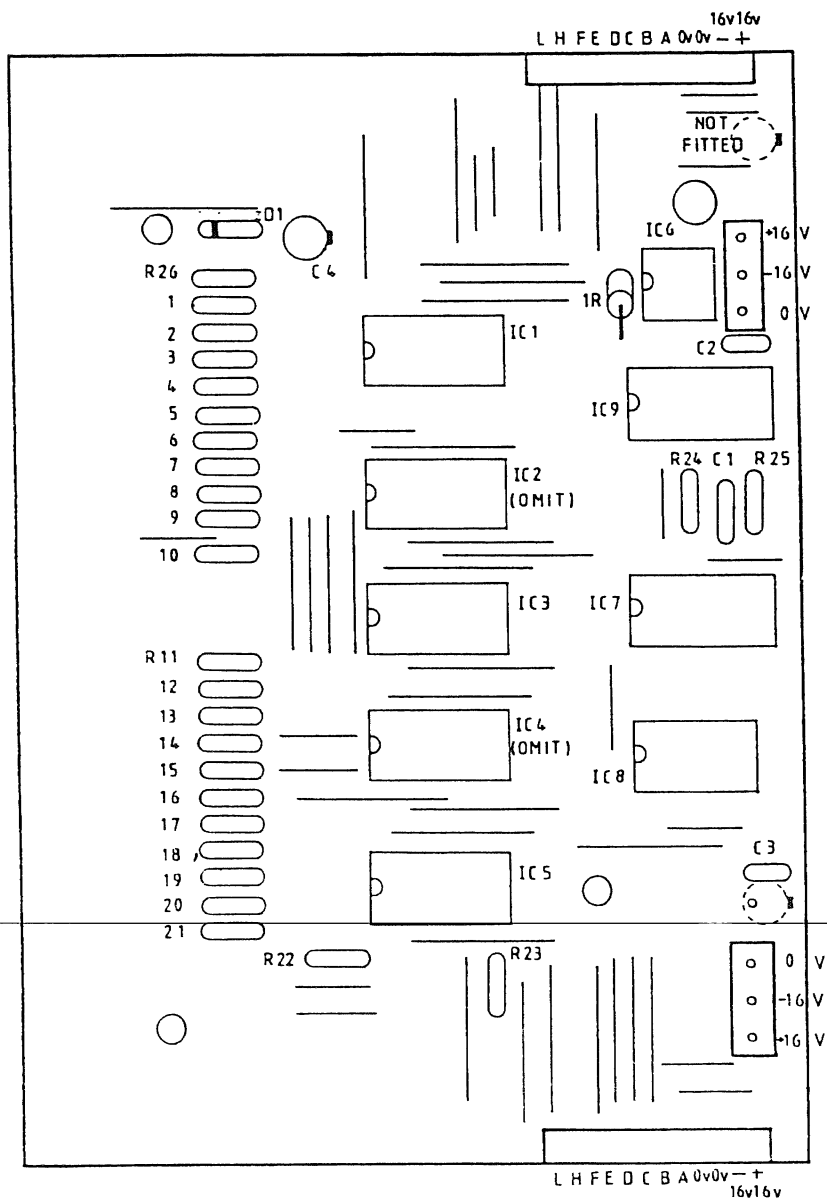

MASTER PCB. AG 0192 ISS. 3

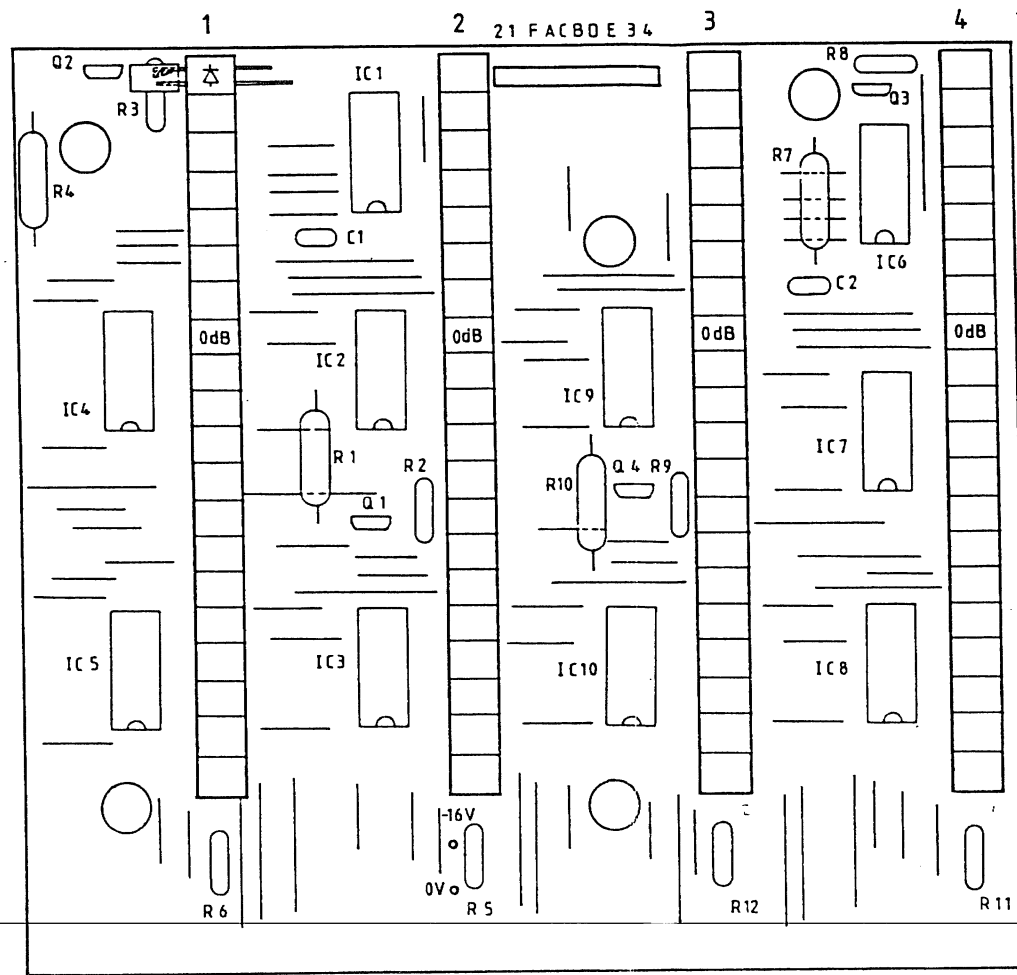

DISPLAY PCB. AG 0190 ISS. 2

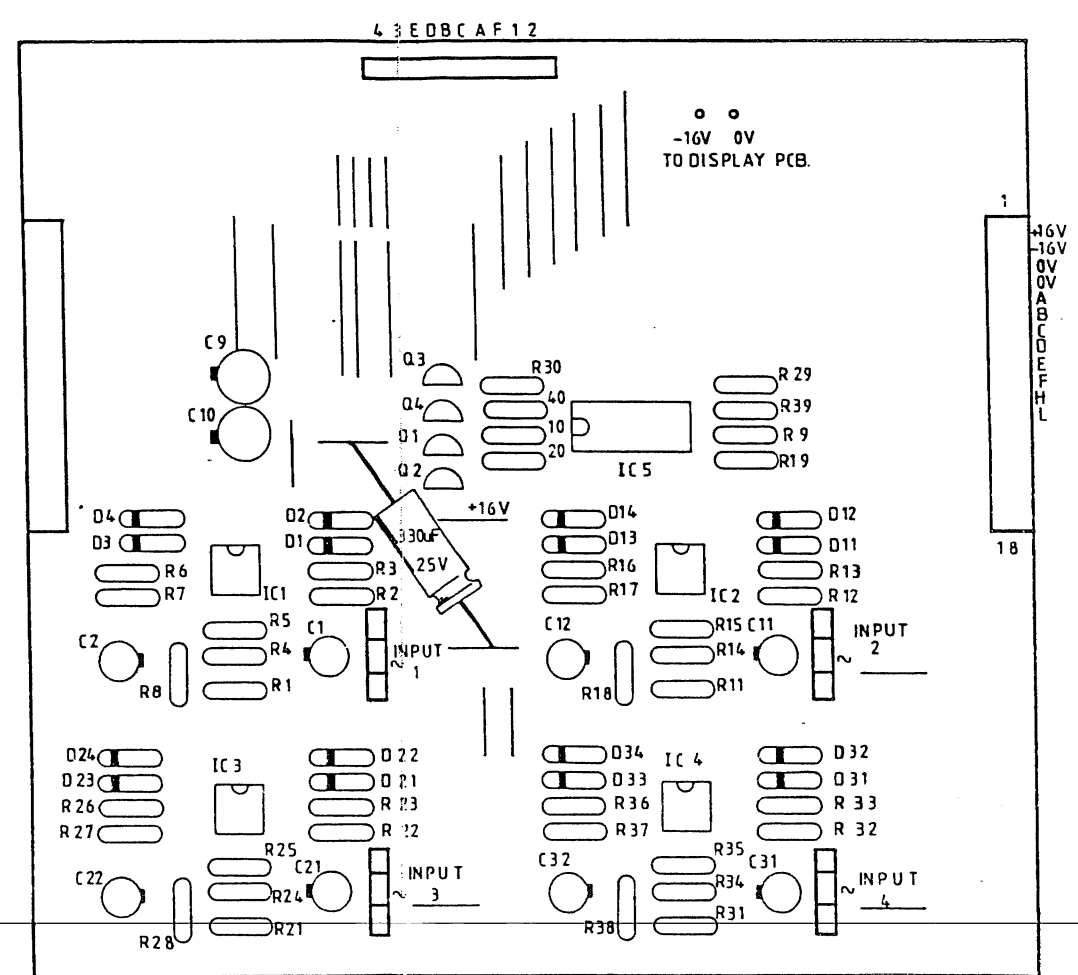

RECTIFIER PCB. AG 0191 ISS. 3

ALLEN & HEATH
 BAR GRAPH METERS
 DRAWING NO. BW 223 ISS. 1

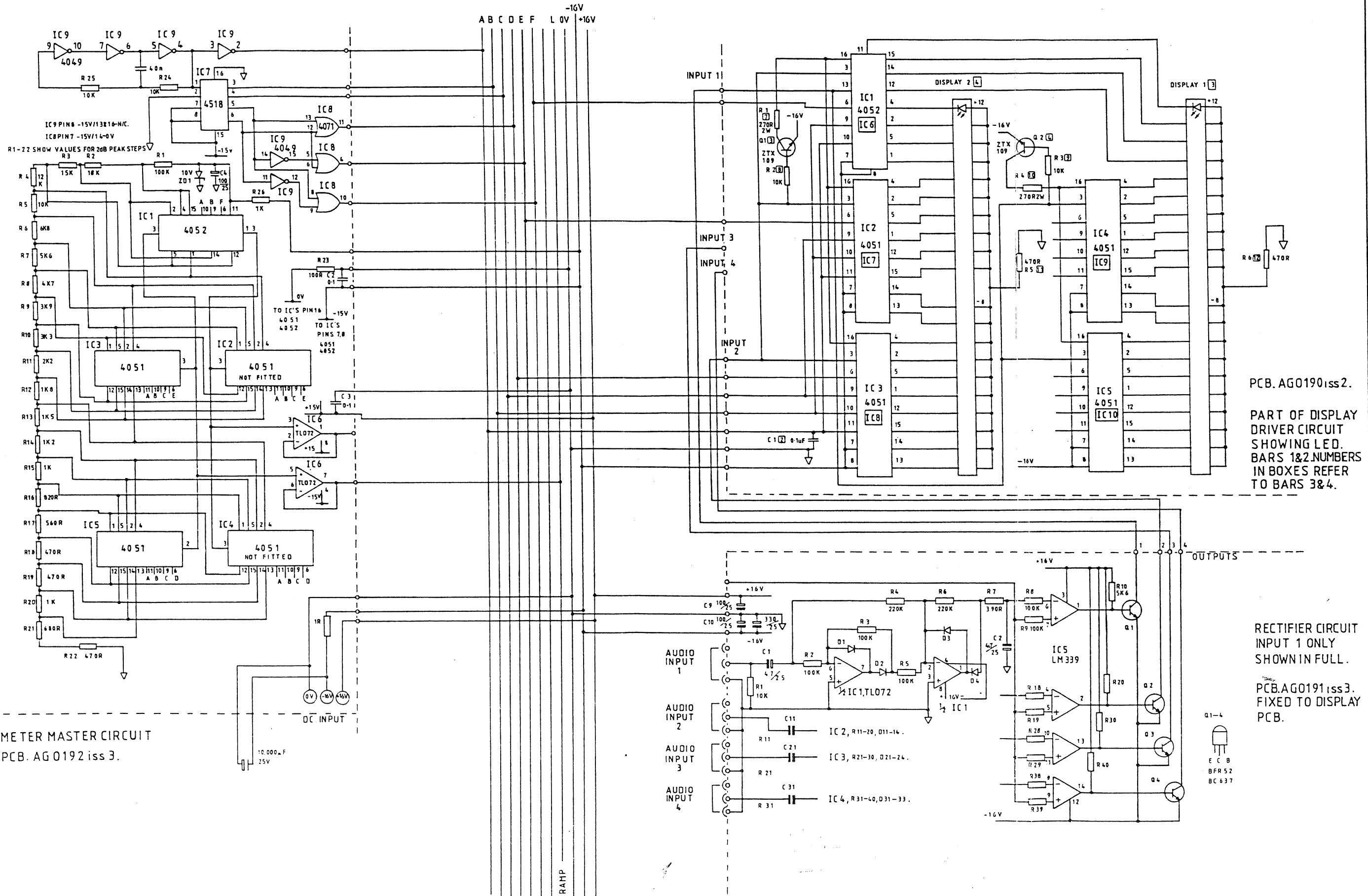

PCB. AG0190 iss2.

PART OF DISPLAY DRIVER CIRCUIT SHOWING LED BARS 1&2 NUMBERS IN BOXES REFER TO BARS 3&4.

RECTIFIER CIRCUIT INPUT 1 ONLY SHOWN IN FULL.

PCB. AG0191 iss3. FIXED TO DISPLAY PCB.

METER MASTER CIRCUIT
PCB. AG 0192 iss 3.

STANDARD NOTES
ALL DIMENSIONS IN mm
DO NOT SCALE DRAWING
THIRD ANGLE PROJECTION
REMOVE ALL BURRS & SHARP EDGES

MATERIAL

TOLERANCES
GENERAL ±0.25 mm
HOLE CENTRES ±0.15 mm
HOLE SIZES ±0.10 mm

FINISH

NOTES
APPLIES TO PCB TYPES:
MASTER - AG0192 iss. 3
RECTIFIER - AG0191 iss. 3
DISPLAY - AG0190 iss. 2

UNIT TITLE
ALLEN & HEATH

DRAWING TITLE
BARGRAPH METER CIRCUIT

AHB ALLEN & HEATH BRENNELL LTD.
PROFESSIONAL AUDIO EQUIPMENT MANUFACTURERS

DESIGN DEPT. 88 SHIP STREET BRIGHTON BN1 1AE TEL 0273 24828
FACTORY: HERRICK INDUSTRIAL EST. PENNYRILL CORNWALL TR 0228 70770

DRAWING No. MBD 189 ISSUE 4

E. J.	1188	DATE	CHECKED
DRAWN	REVISION	DATE	CHECKED

UNLESS STATED OTHERWISE

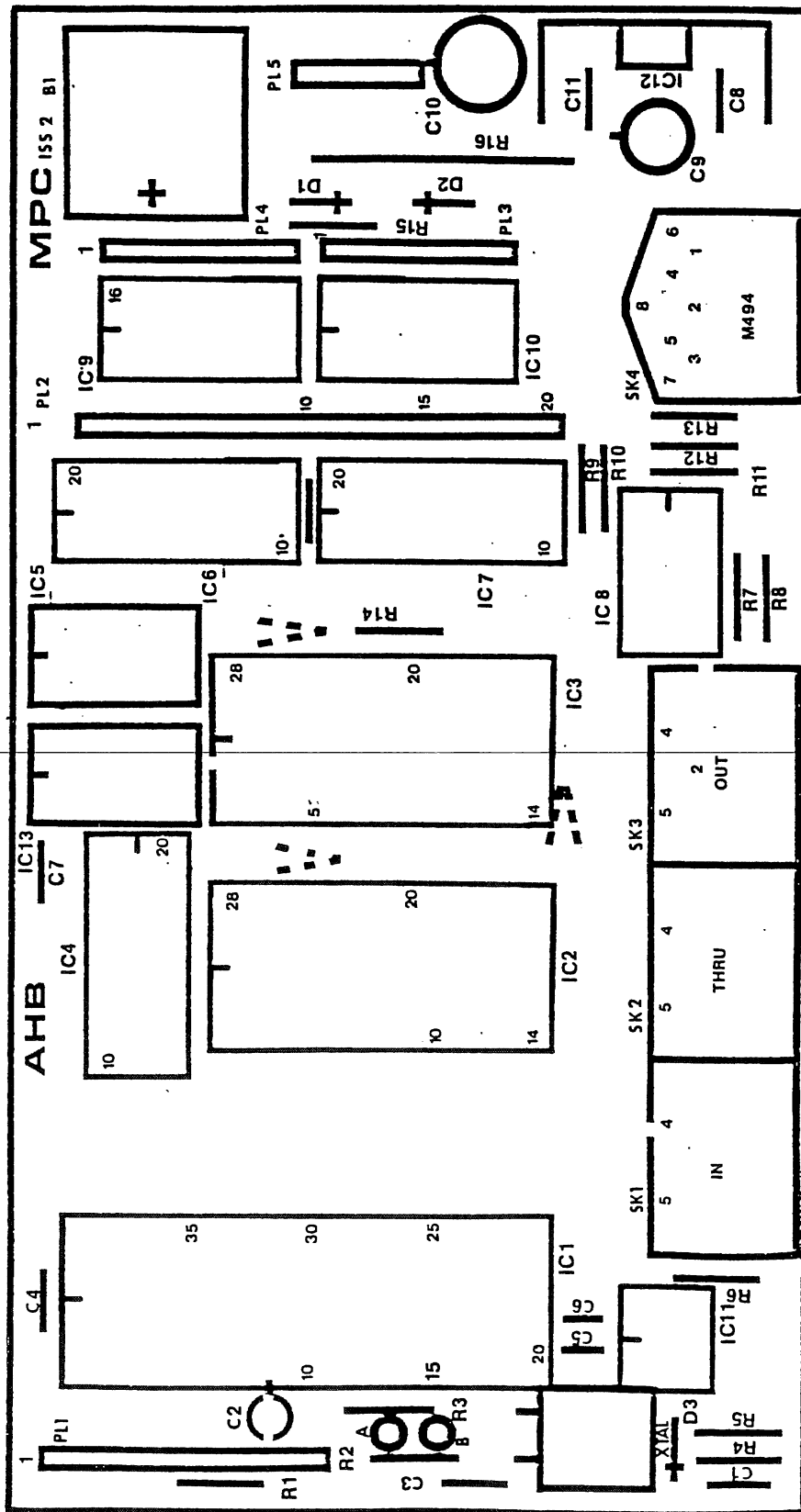

AHB

ALLEN & HEATH BRENELL LTD.

PROFESSIONAL AUDIO EQUIPMENT
MANUFACTURERS

'DESIGN DEPT' 69 SHIP STREET, BRIGHTON BN1 1AE Tel (0273) 24928
'FACTORY' KERNICK INDUSTRIAL EST, PENRYN, CORNWALL Tel (0326) 72070

DRAWING No.

BW 224

Issue

1

MUTE PROCESSOR COMPUTER PCB. ASSEMBLY

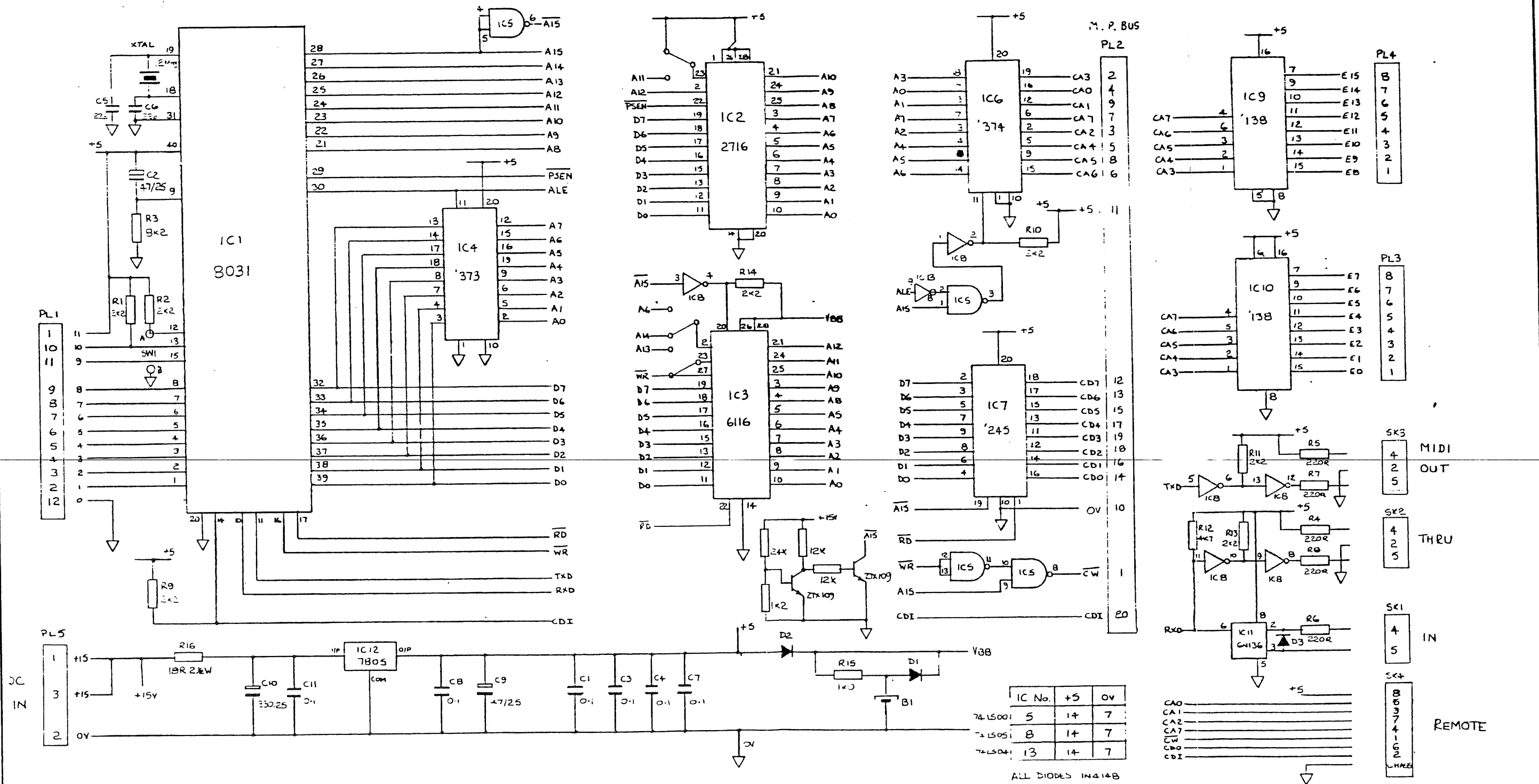

DATE	REVISION	CHECKED

STANDARD NOTES
 ALL DIMENSIONS IN mm
 DO NOT SCALE DRAWING
 THIRD ANGLE PROJECTION
 REMOVE ALL BURRS & SHARP EDGES
 SCALE

MATERIAL

TOLERANCES
 GENERAL ±0.25 mm
 HOLE CENTRES ±0.15 mm
 HOLE SIZES ±0.10 mm
 UNLESS STATED OTHERWISE

FINISH

NOTES
 PCB AHB MPC AG 0186

UNIT TITLE
 AHB MUTE PROCESSOR
DRAWING TITLE
 AHB MUTE PROCESSOR CARD

AHB ALLEN & HEATH ORNELL LTD
 PROFESSIONAL AUDIO EQUIPMENT MANUFACTURERS
 DESIGN DEPT. 64-66P STREET, BRADFORD BD9 4JF
 FACTORY: WERNICK INDUSTRIAL EST., PENNYL, COVINGHAM, W. SUSSEX BN20 7JN
 DRAWING No. MBD 190 Issue 2

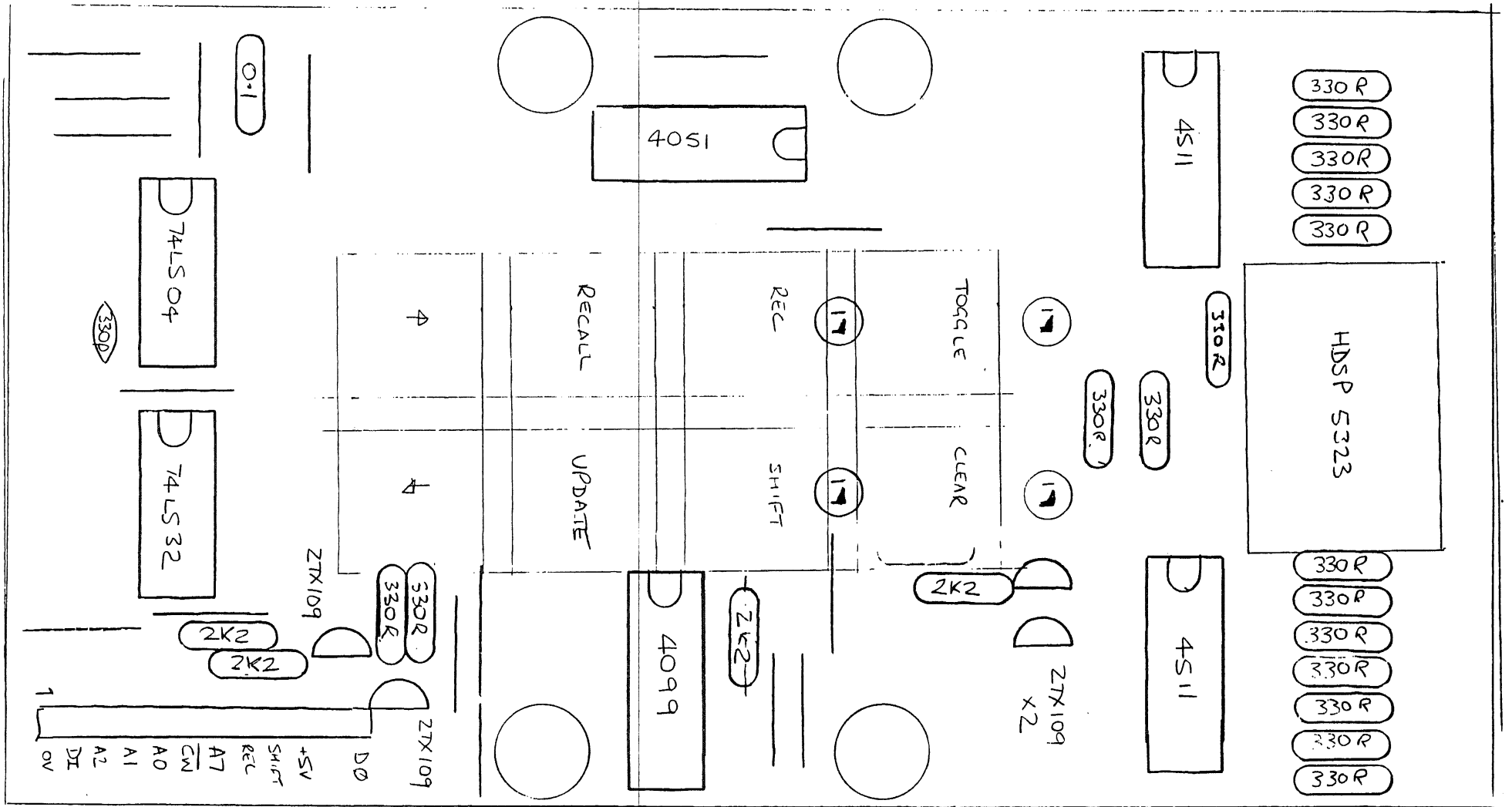

MUTE PROCESSOR KEYBOARD PCB. AGO21B 1ss 1

DRAWING NO. BW225 1ss 1

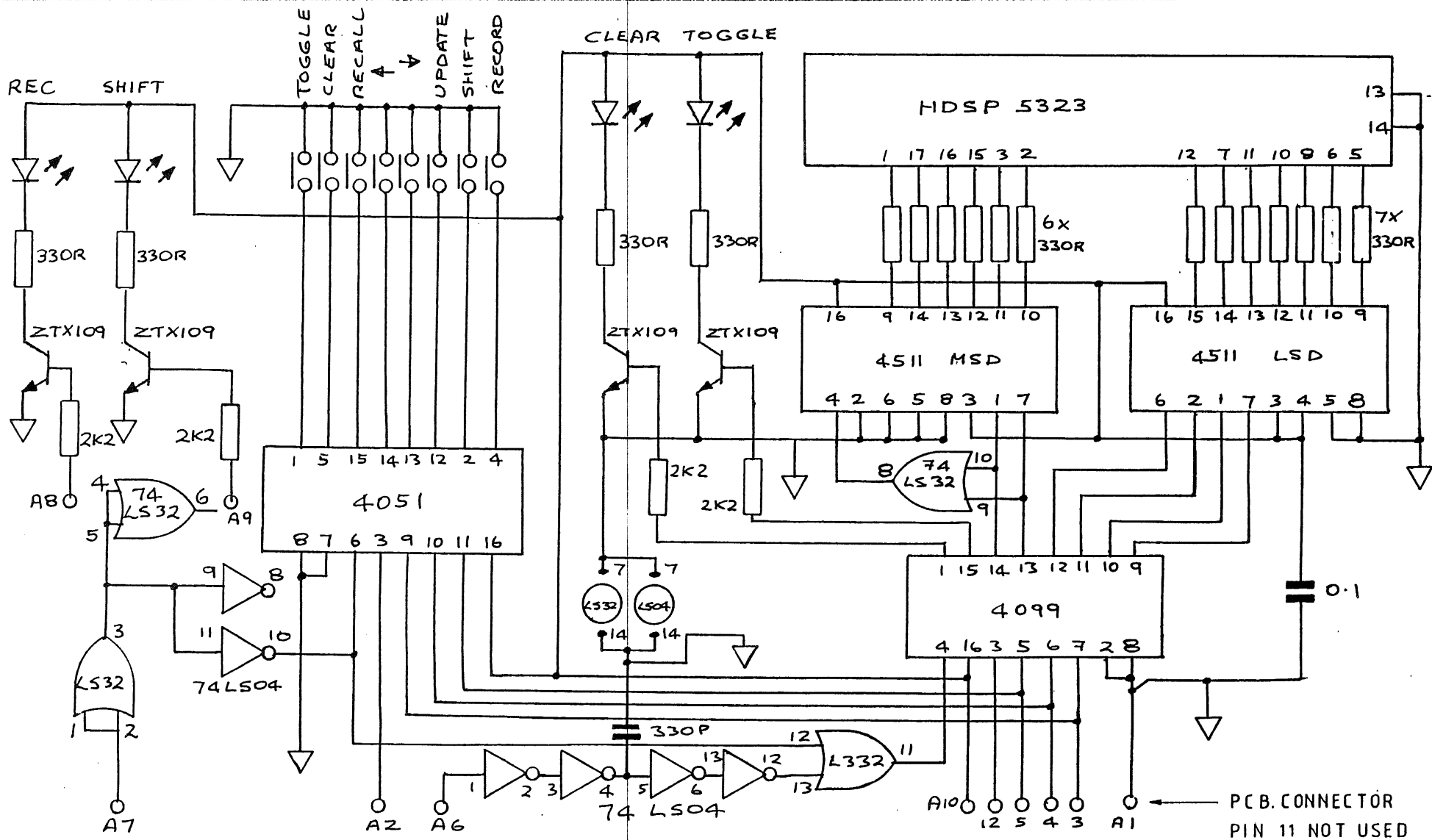

AHB

ALLEN & HEATH BRENELL LTD.
 PROFESSIONAL AUDIO EQUIPMENT
 MANUFACTURERS

'DESIGN DEPT' 69, SHIP STREET, BRIGHTON BN1 1AE Tel (0273) 24928
 'FACTORY' KERFACK INDUSTRIAL EST, PENRYN, CORNWALL. Tel (0326) 72070

TITLE

MUTE PROCESSOR

KEYBOARD PCB. AG0218 ISSUE 1
 CIRCUIT DIAGRAM

DRG.No. 698. ISS. 1.

DRAWING No. 698

ISSUE 1

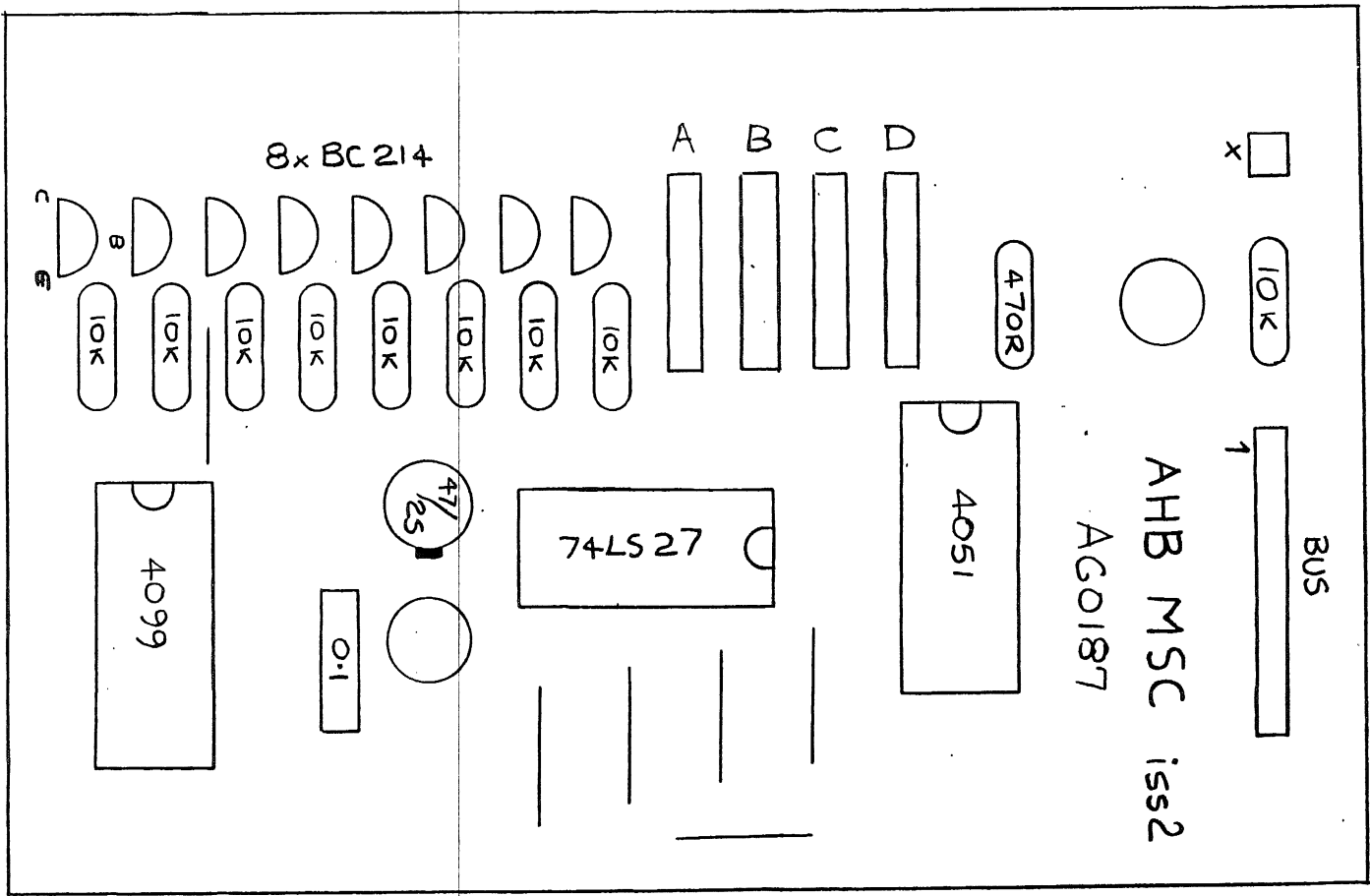

MUTE PROCESSOR SLAVE PCB :

DRAWING NO. BW226 Iss. 1

MUTE OUT (TX) — 1
 MUTE IN (RX) — 2
 MUTE OUT (TX) — 3
 MUTE IN (RX) — 4
 NOT USED — 5

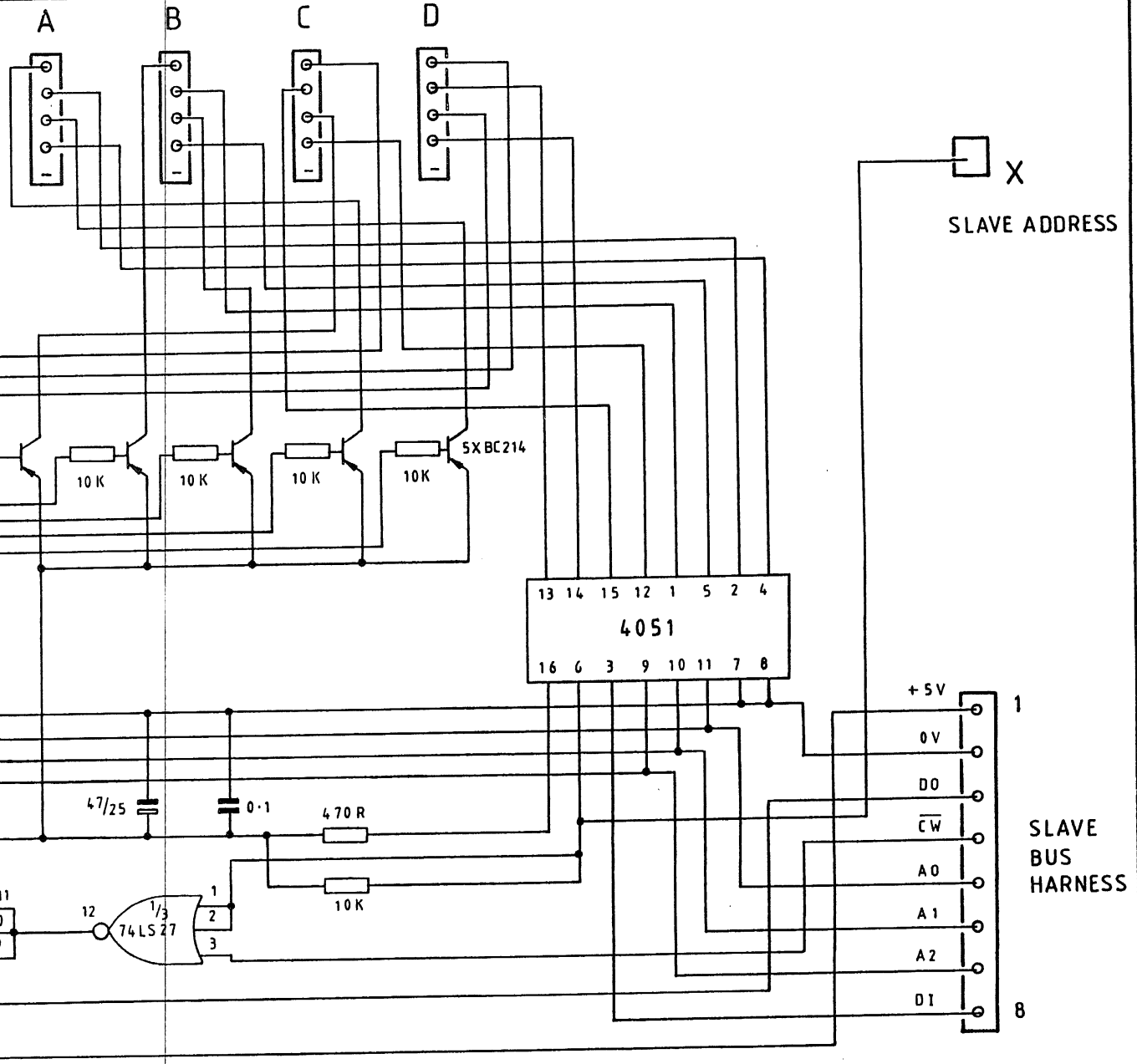

DATE	189	CH/REV	1
REVISION			
DRAWN	E. J.		

STANDARD NOTES
 ALL DIMENSIONS IN mm
 DO NOT SCALE DRAWING
 THIRD ANGLE PROJECTION
 REMOVE ALL BURRS & SHARP EDGES

SCALE

MATERIAL

TOLERANCES
 GENERAL ± 0.25 mm
 HOLE CENTRES ± 0.15 mm
 HOLE SIZES ± 0.10 mm

UNLESS STATED OTHERWISE

FINISH

NOTES
 74LS27 PIN 7=0V
 PIN 14=+5V

UNIT TITLE
 MUTE PROCESSOR SLAVE

DRAWING TITLE
 CIRCUIT FOR PCB. AGO 187 ISS.2

AHB ALLEN & HEATH ENGINEERS LTD
 PROFESSIONAL AUDIO EQUIPMENT MANUFACTURERS
 DESIGN DEPT. 45 SHIP STREET, BRISTOL, GLOUCESHIRE, BS1 3BN
 FACTORY WAREHOUSE INDUSTRIAL ESTATE, REDDING, OXFORDSHIRE, OX20 2JN

DRAWING NO. A 164

2

ARTWORKER PDS 880451

MUTE PROCESSOR
 MPC. PCB. AG0186
 CIRCUIT DRAWING MBD 190.
 PART OF M302 & M305 CONNECTOR
 PANEL ASSEMBLIES

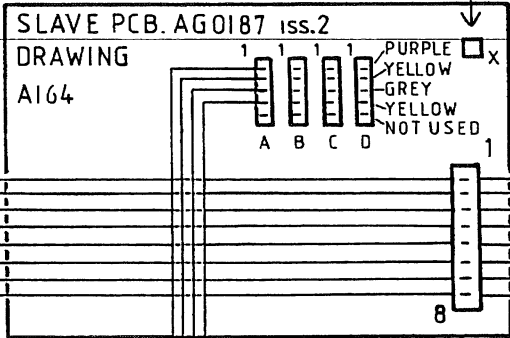
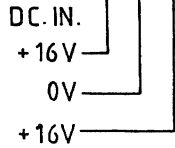
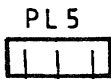
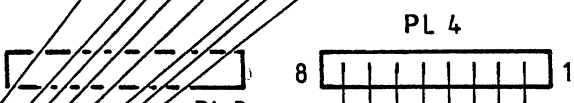
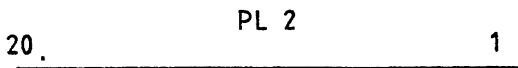
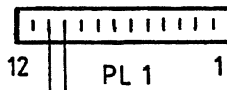

SLAVE BUS
 HARNESS

SLAVE
 ADDRESS HARNESS
 ONE LINE TO EACH
 SLAVE CARD

TO MODULES M310, M320, M325, M330,
 M350, M355
 AUDIO HARNESS CONNECTORS 'A&C'

TX. RX. TX. RX.

REMOTE SOCKET
 ON REAR PANEL
 IN PARALLEL
 WITH MCC
 KEYBOARD

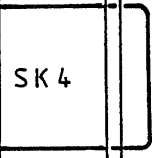

HARNESS
 CONTINUES
 TO OTHER
 SLAVES

KEYBOARD MCC.
 PCB. AG0218 iss.1
 DRAWING A163
 PART OF M350
 & M355 MODULES

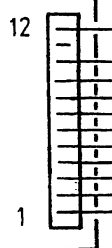

DRAWING NO.

AHB ALLEN HEATH BRENELL LTD MANUFACTURERS OF AUDIO EQUIPMENT 100, THE STREET, BARNET, Herts. EN4 3PH TEL: 0452 373333 FAX: 0452 373333 DRAWING NO. 663 REVISED 1	
UNIT TITLE SABER MUTE PROCESSOR	DRAWING TITLE WIRING
NOTES SEE FRAME WIRING DRAWING 664 DRAWING 693	FINISH TOLERANCES GENERAL ±0.25 mm HOLE CENTRES ±0.15 mm HOLE SIZES ±0.10 mm UNLESS STATED OTHERWISE
MATERIAL	STANDARD NOTES ALL DIMENSIONS IN mm DO NOT SCALE DRAWING THIRD ANGLE PROJECTION REMOVE ALL BURRS & SHARP EDGES SCALE
DATE 1/1/77 DRAWN E.J. CHECKED APPROVED REVISION	DATE 1/1/77 DRAWN E.J. CHECKED APPROVED REVISION

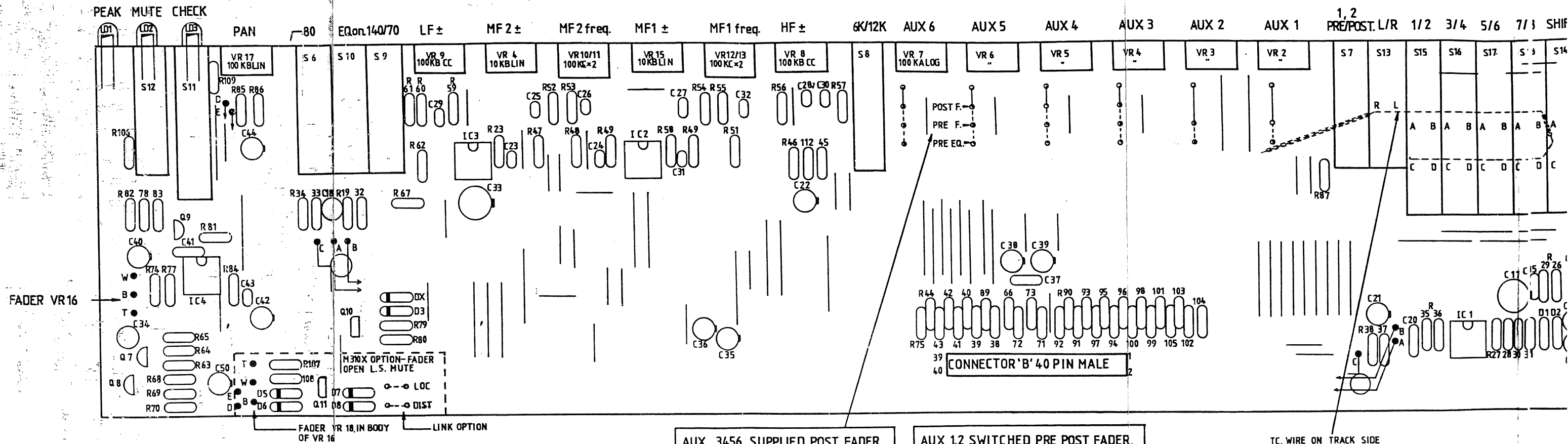

AUX 3,4,5 SUPPLIED POST FADER,
LINK OPTIONS—PRE FADE, PRE EQ.

AUX 1,2 SWITCHED PRE POST FADER,
LINK OPTION PRE EQ. " "

ALLEN & HEATH SABER INPUT M 310(X)
PCB. AGO200 ISSUE 3.

DRAWING NO. BW 323 ISS. 1

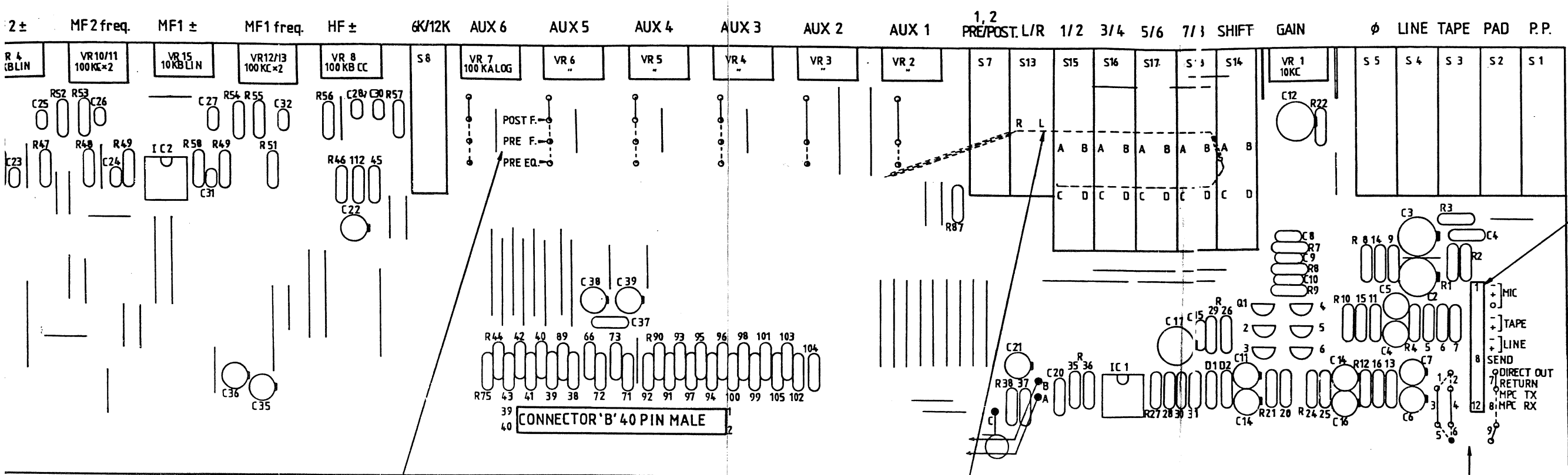

AUX 3,4,5,6 SUPPLIED POST FADER,
LINK OPTIONS—PRE FADE, PRE EQ.

AUX 1,2 SWITCHED PRE POST FADER,
LINK OPTION PRE EQ. " "

TC. WIRE ON TRACK SIDE

INSERT OPTIONS	
PRE 80Hz. PRE EQ. FIT LINKS	1,5,4,8 ONLY
POST " " " "	3,2,6,8 "
" " POSTEQ. " "	3,4,7,9 "

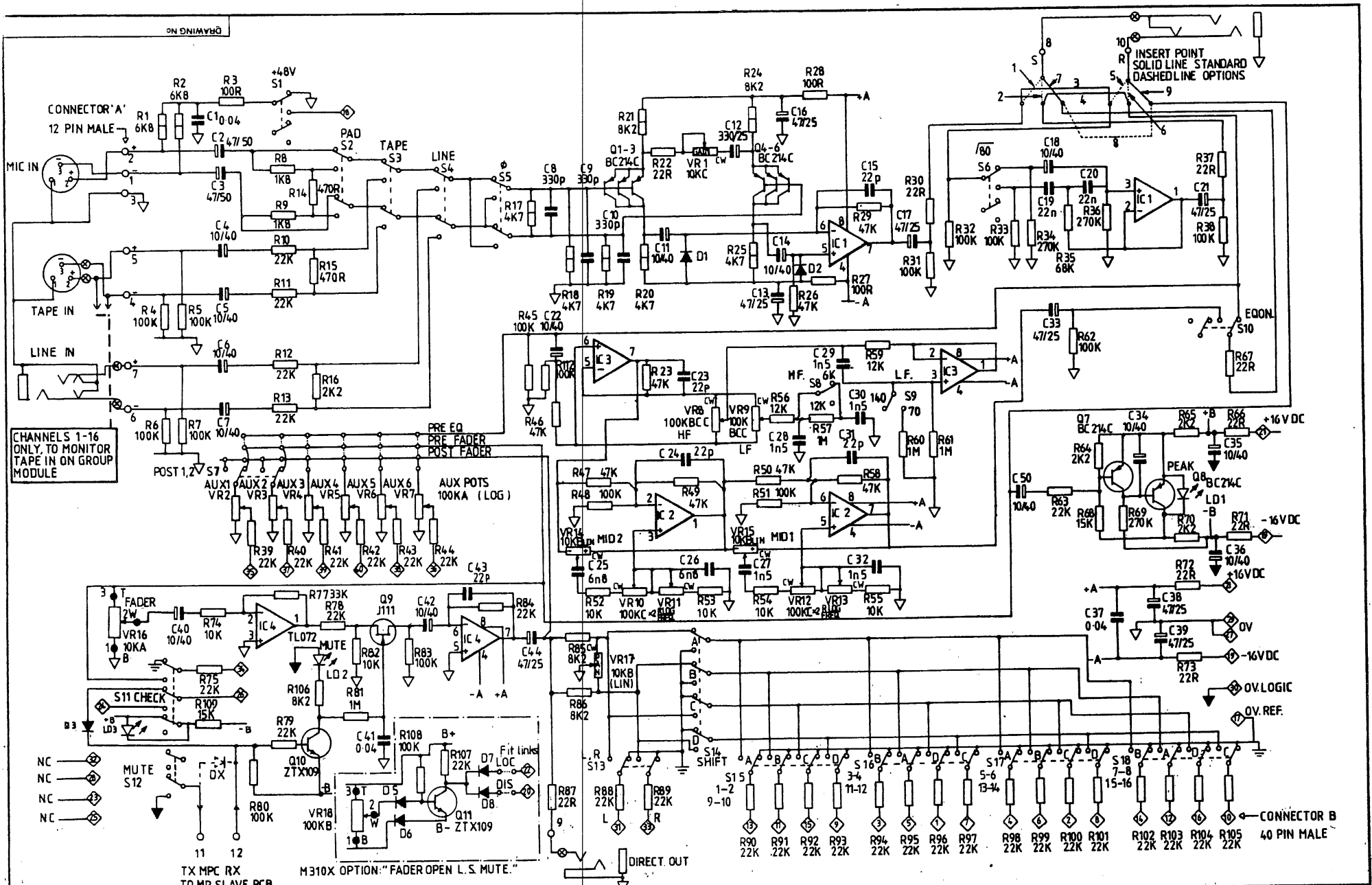

<p>E:2 PRODUCTION GMA © 1978</p>	<p>STANDARD NOTES ALL DIMENSIONS IN mm DO NOT SCALE DRAWING THIRD ANGLE PROJECTION REMOVE ALL BURRS & SWAMP EDGES</p>	<p>MATERIAL</p>	<p>TOLERANCES GENERAL ±0.25 mm HOLE CENTRES ±0.15 mm HOLE SIZES ±0.10 mm</p>	<p>FINISH UNLESS STATED OTHERWISE</p>	<p>NOTES REFER TO COMPONENT REFERENCE SHEET □ 1% RESISTOR ○ PATCHBAY INTERFACE OPTIONAL</p>	<p>UNIT TITLE ALLEN & HEATH SABER M310X INPUT MODULE DRAWING TITLE Circuit Detail PCB AG0200 iss 3</p>	<p>AHB ALLEN & HEATH SABER LTD. PROFESSIONAL AUDIO EQUIPMENT MANUFACTURERS 667</p>
--------------------------------------	-------------------------------------------------------------------------------------------------------------------------------------------	-----------------	------------------------------------------------------------------------------------------	-------------------------------------------	---------------------------------------------------------------------------------------------------------	--------------------------------------------------------------------------------------------------------------------------------	-------------------------------------------------------------------------------------------------------

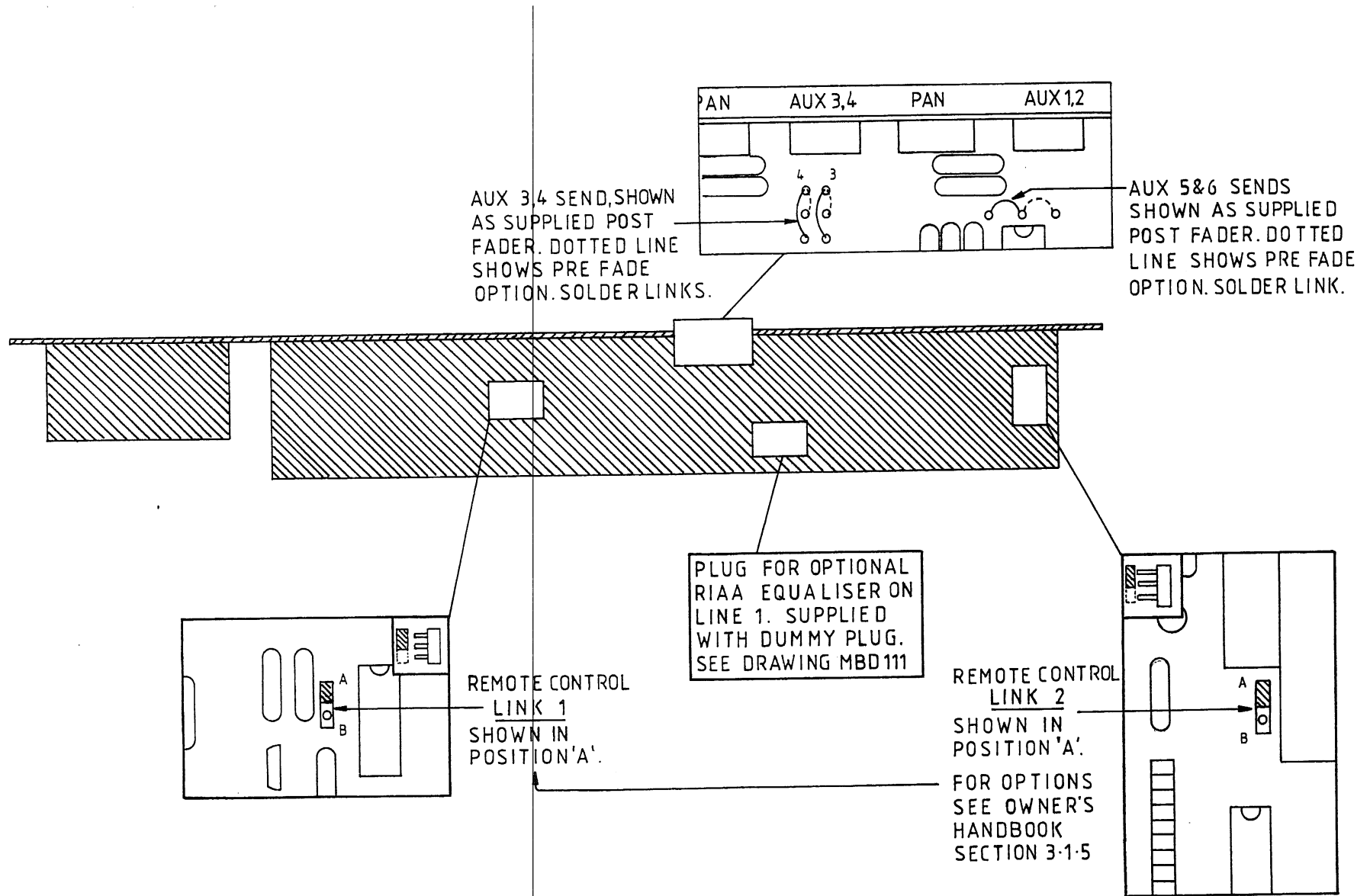

M360 MODULE PCB. AG0205

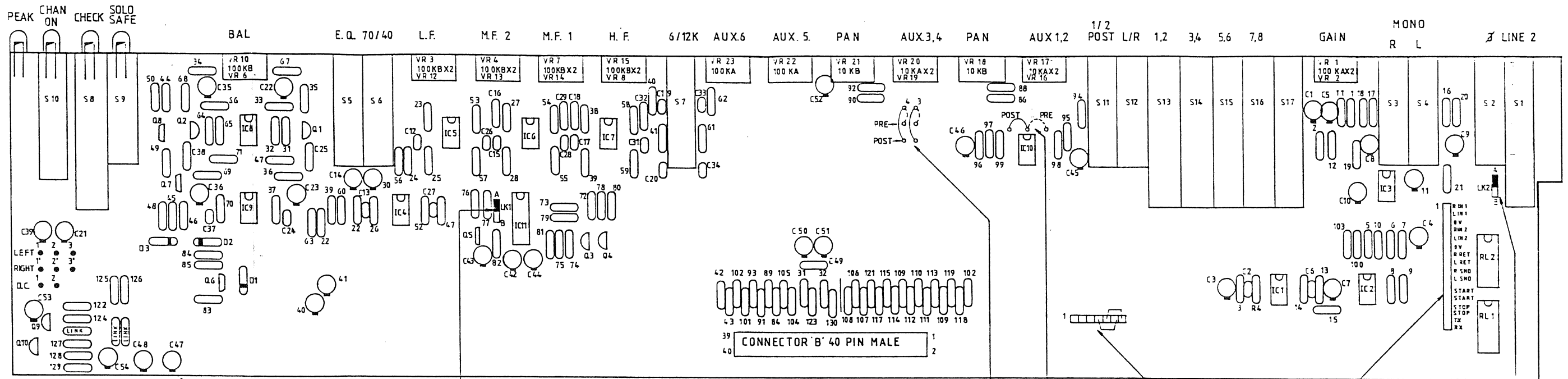

ALLEN & HEATH SABER M360
 STEREO INPUT PCB. AG0205 ISSUE 1

DRAWING NO. BW 324 ISS. 1

LINK 1. POSITION 'A'. REMOTE SWITCHING LATCHED
 POSITION 'B'. REMOTE SWITCHING MOMENTARY

AUX 3/4 SEND SUPPLIED POST FADER. LINK OPTION PRE FADER	AUX 5&6 SENDS SUPPLIED POST FADER. LINK OPTION PRE FADER	7 PIN CONNECTOR FOR OPTIONAL RIAA EQUALISER ON LINE 1. DUMMY PLUG SHOWN	CONNECTOR 'A' 16 PIN MALE	LINK 2. POSITION 'A'. REMOTE SOCKET ACTIVE FOR LINE 1&2. POSITION 'B'. REMOTE SOCKET ACTIVE FOR LINE 1 ONLY.
---------------------------------------------------------	----------------------------------------------------------	-------------------------------------------------------------------------	---------------------------	--------------------------------------------------------------------------------------------------------------

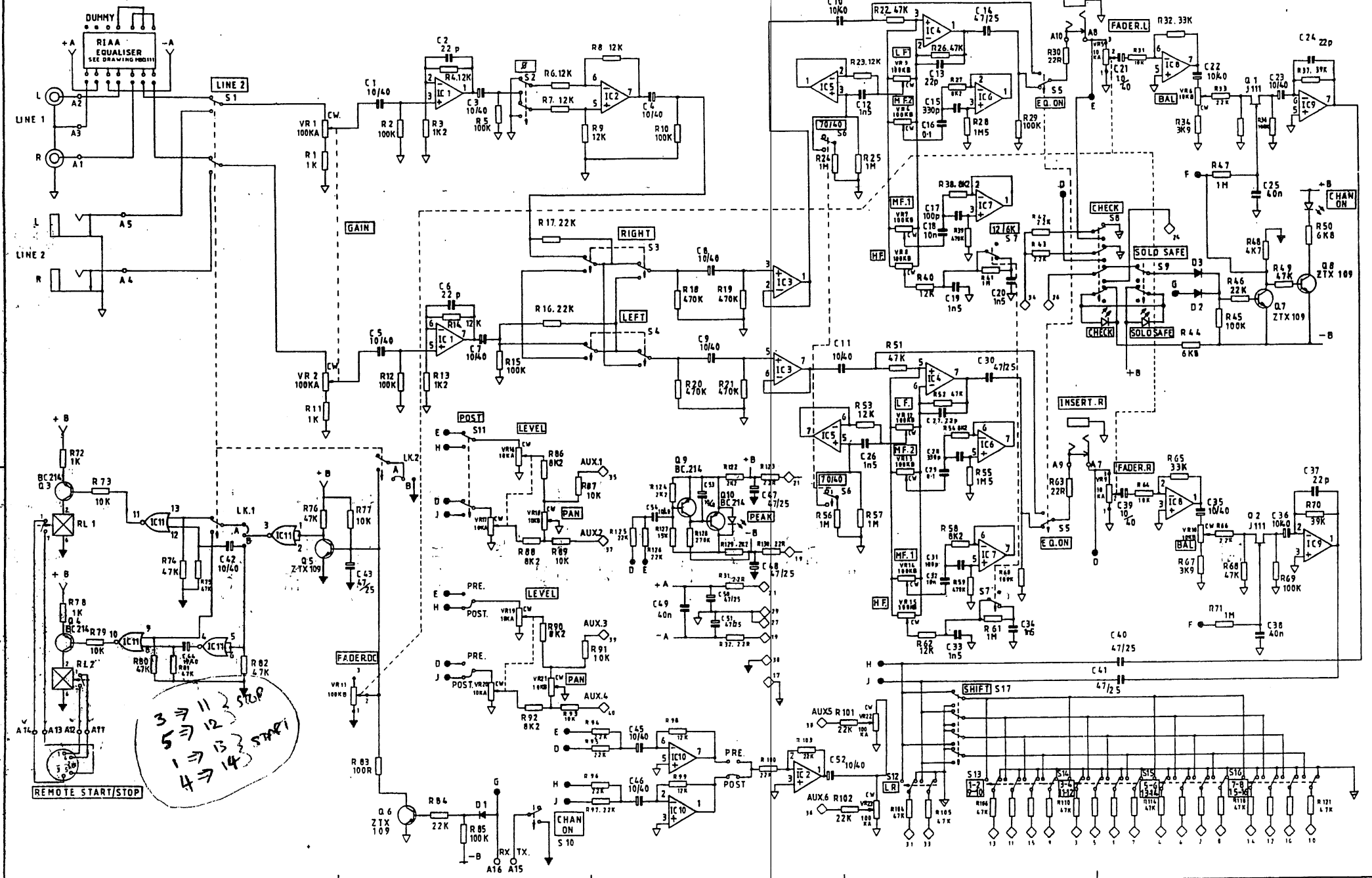

PRODUCTION	1-4-89
REVISION	2/11/89
DATE	2/11/89
DESIGNED BY	
CHECKED BY	
APPROVED BY	

STANDARD NOTES
 ALL DIMENSIONS IN mm
 DO NOT SCALE DRAWING
 THIRD ANGLE PROJECTION
 REMOVE ALL BURRS & SHARP EDGES

SCALE

MATERIAL

NOTES
 REFER TO COMPONENT REFERENCE SHEET

NOTES
 RELAYS SHOWN RELAXED.
 THIS SYMBOL SHOWS PARTS OF THE CIRCUIT WHICH ARE COMMONED ACCORDING TO LETTERS.

NOTES
 ICs 1 TO 10 TL072
 SUPPLY 'A' TO PIN 4, -PIN 8
 IC 11 4066
 SUPPLY 'A' TO PIN 7, -PIN 16
 ONE PIN OF PCB CONNECTOR B
 VIA PCB CONNECTOR 'A'

UNIT TITLE
 ALLEN & HEATH SABER M360 STEREO MODULE

DRAWING TITLE
 PCB AG0205 ISSUE 1.

AHB ALLEN & HEATH BRENELL LTD
 PROFESSIONAL AUDIO EQUIPMENT MANUFACTURERS
 DESIGN DEPT. BRUSH STREET, BRIDGTON BN 1 3JF TEL 01273 20001
 FACTORY NETWORK INDUSTRIAL EST. PERDUE CROSSING, TEL BR008 7200

DRAWING No. 668

ISSUE 1

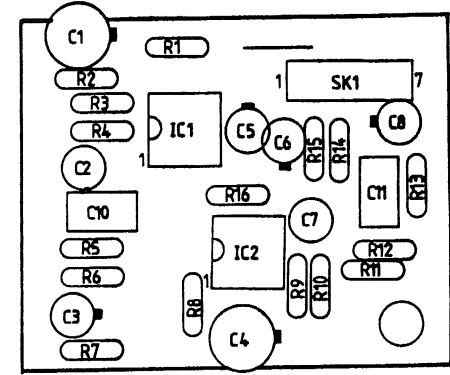
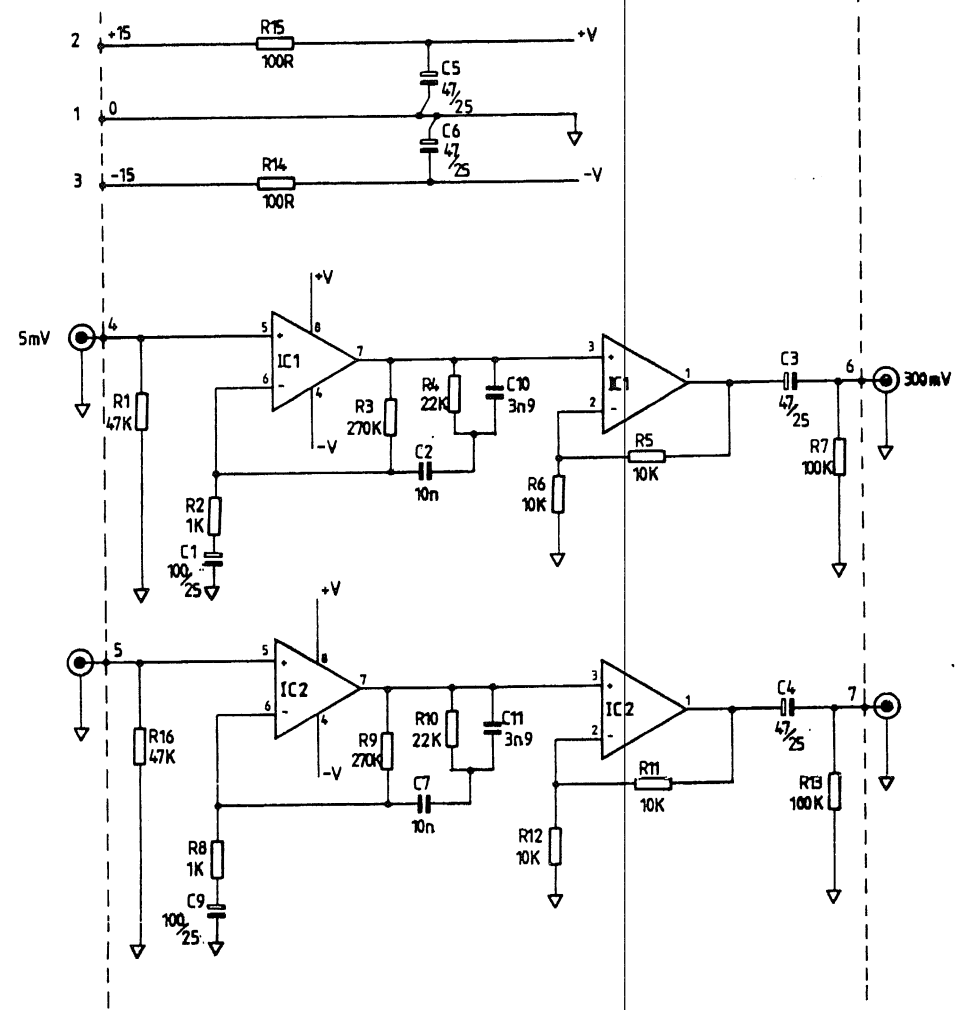

RIAA COMPONENT OVERLAY

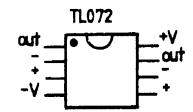

CAPACITORS SHOWN VALUE/VOLTAGE

ALTERATIONS			
No.	DESCRIPTION	CHK'D APP'D	DATE
GMR	ORIGIN		26-2-85

CMC SERIES
 RIAA EQUALISED PRE-AMP
 RIAA PCB AG0102 iss 1

AHB
 69 SHIP STREET,
 BRIGHTON
 BN1 1AE
 Tel 0273 24928

DRAWN	TRACED	CHECKED	APPROVED	DATE	SCALE
GMR	KRP	TR		26-2-85	

DRAWING No. MBD111 iss1

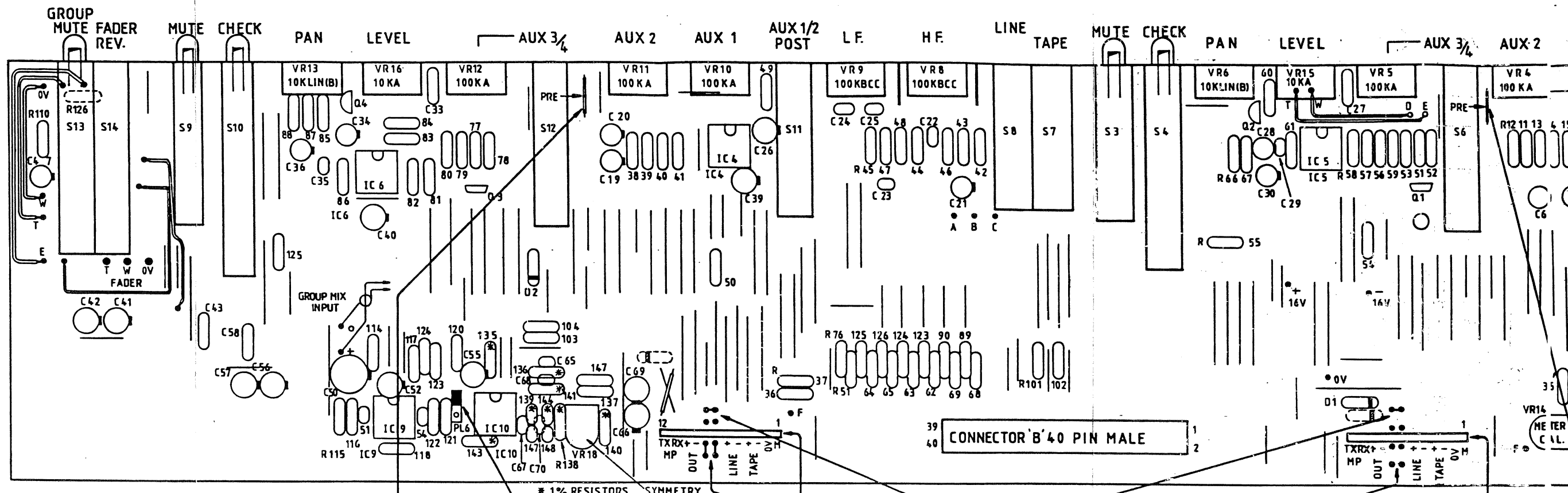

ALLEN & HEATH SABER M320
 GROUP PCB AG0201 ISSUE 3
 DRAWING NO. BW 325 ISS. 1

AUX 3/4
 SUPPLIED
 POST FADE.
 LINK OPTION
 PRE FADE

GROUP OUTPUT
 LEVEL PL. 6.
 SHOWN IN HIGH
 +4dBu POSITION
 OPTIONAL -8dBu
 BY MOVING JUMPER
 INTO OTHER POSITION

CONNECTOR 'C' 12 PIN MALE

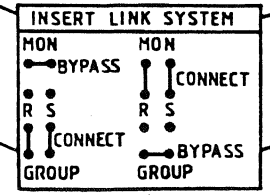

CONNECTOR 'A' 12 PIN MALE

* 1% RESISTORS SYMMETRY

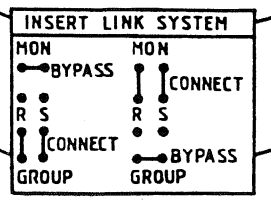
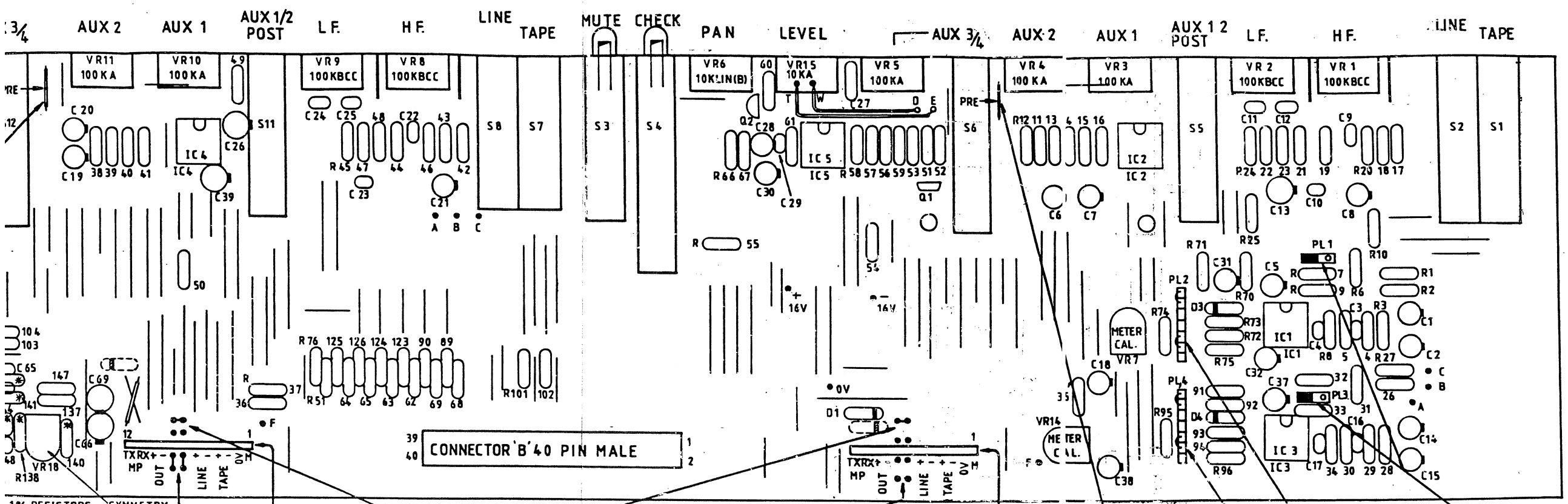

<p>AUX 3/4 SUPPLIED POST FADE, LINK OPTION PRE FADE</p>	<p>METER DRIVE SELECT SHOWN IN BARGRAPHS POSITION. ROTATING PLUGS 2, AND 4 GIVES MECHANICAL METERS POSITION</p>	<p>MONITOR INPUT LEVEL SHOWN IN HIGH +4dBu POSITION OPTIONAL -8dBu BY MOVING JUMPER INTO OTHER POSITION</p>
---------------------------------------------------------	-----------------------------------------------------------------------------------------------------------------	-------------------------------------------------------------------------------------------------------------

ER
ITION

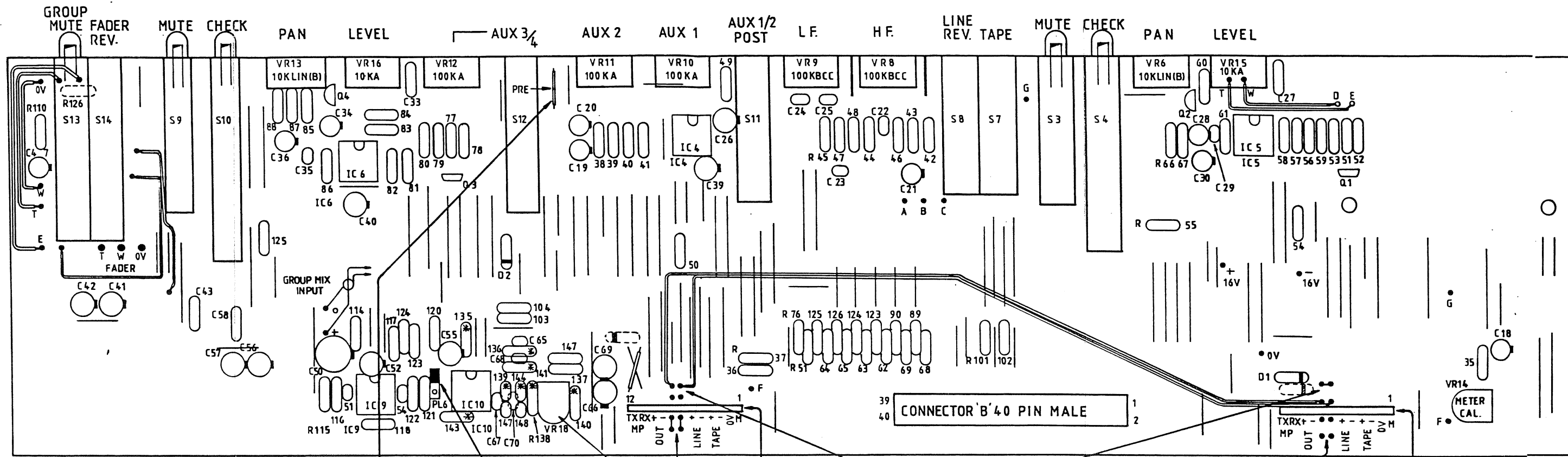

ALLEN & HEATH SABER M325
 GROUP PCB AG0201 ISSUE 3
 DRAWING NO. BW 326 ISS. 1

AUX 3/4 SUPPLIED POST FADE. LINK OPTION PRE FADE

GROUP OUTPUT LEVEL PL. 6. SHOWN IN HIGH +4dBu POSITION. OPTIONAL -8dBu BY MOVING JUMPER INTO OTHER POSITION

CONNECTOR 'C' 12 PIN MALE

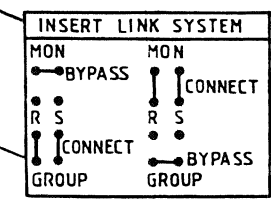

CONNECTOR 'A' 12 PIN MALE

CONNECTOR 'B' 40 PIN MALE

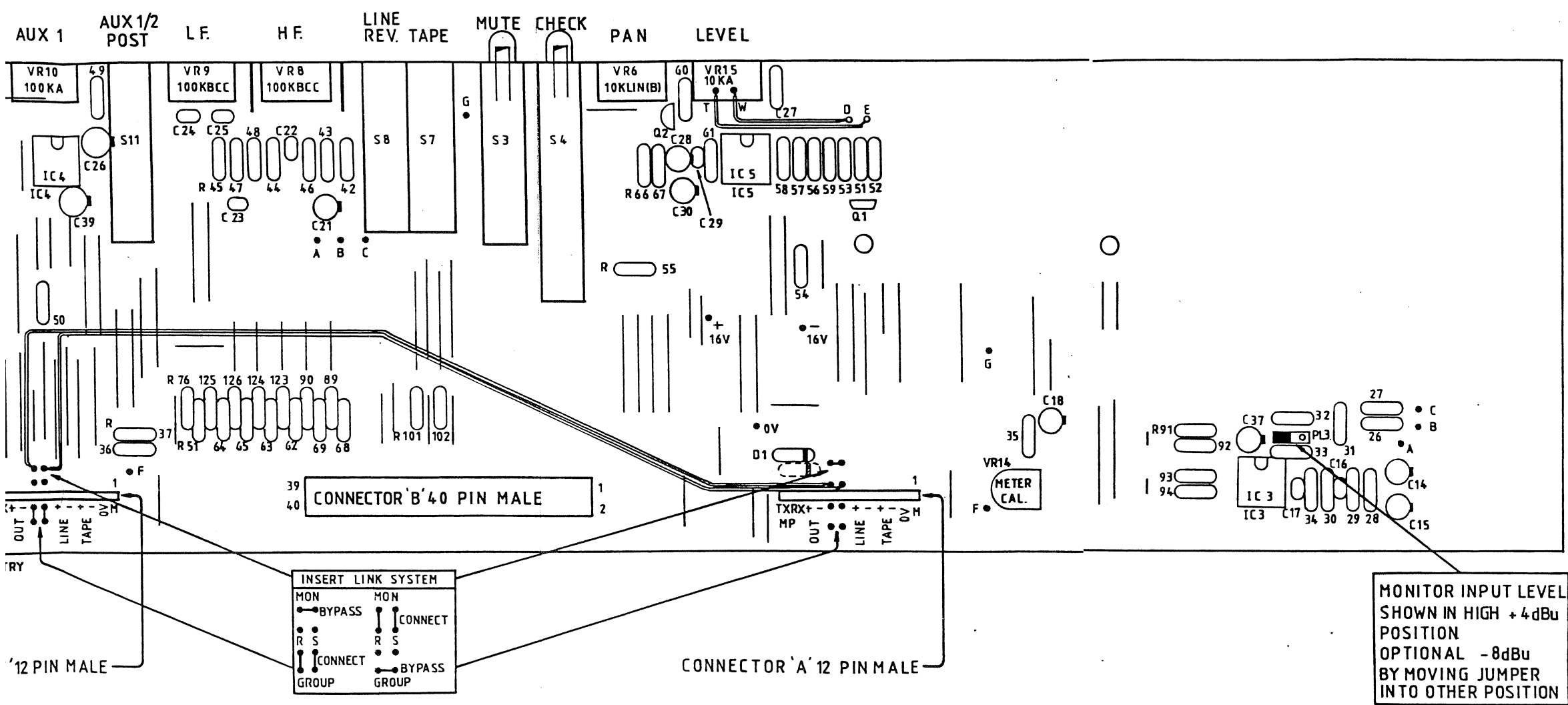

MONITOR INPUT LEVEL
 SHOWN IN HIGH +4dBu
 POSITION
 OPTIONAL -8dBu
 BY MOVING JUMPER
 INTO OTHER POSITION

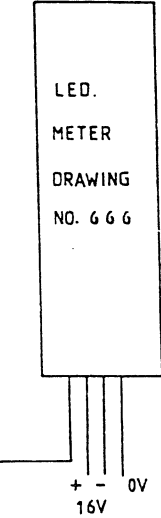
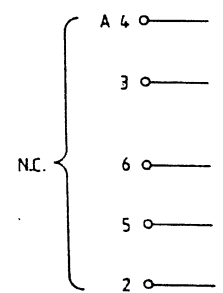
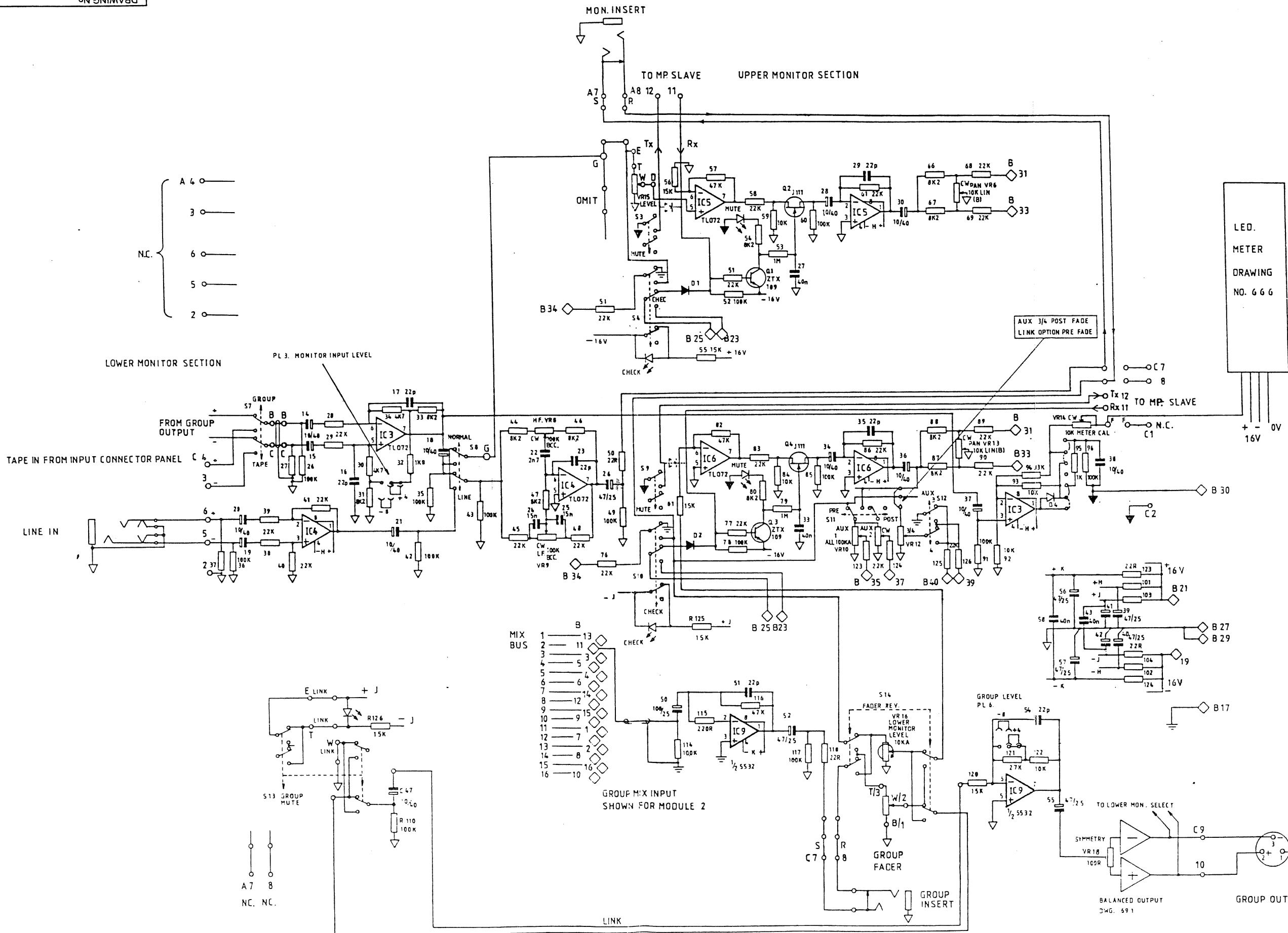

GMR ORIGIN	10.87	STANDARD NOTES ALL DIMENSIONS IN mm DO NOT SCALE DRAWING THIRD ANGLE PROJECTION REMOVE ALL BURRS & SHARP EDGES	MATERIAL	TOLERANCES GENERAL ±0.25 mm HOLE CENTRES ±0.15 mm HOLE SIZES ±0.10 mm	FINISH	NOTES REFER TO COMPONENT REFERENCE SHEET	UNIT TITLE ALLEN & HEATH SABER M325 GROUP MODULE (PA)	ALLEN & HEATH BRENNELL LTD. PROFESSIONAL AUDIO EQUIPMENT MANUFACTURERS DESIGN DEPT 89 SHIP STREET, BRIGHTON BN1 1AE Tel 01273 24928 FACTORY KERRICK INDUSTRIAL EST PENNYRN CORNWALL Tel 01326 72070
E J PRODUCTION	19.1.89							
DRAWN	REVISION	DATE	CHECKED	UNLESS STATED OTHERWISE			DRAWING TITLE CIRCUIT DIAGRAM FOR PCB AGO 201 Iss 3	DRAWING No. 686



1 +15 +12 +9 +6 +3 +15 0 -15 -3 -6 1-9 -12 -15 -18 -21 -24 -27 -30 -33 -36

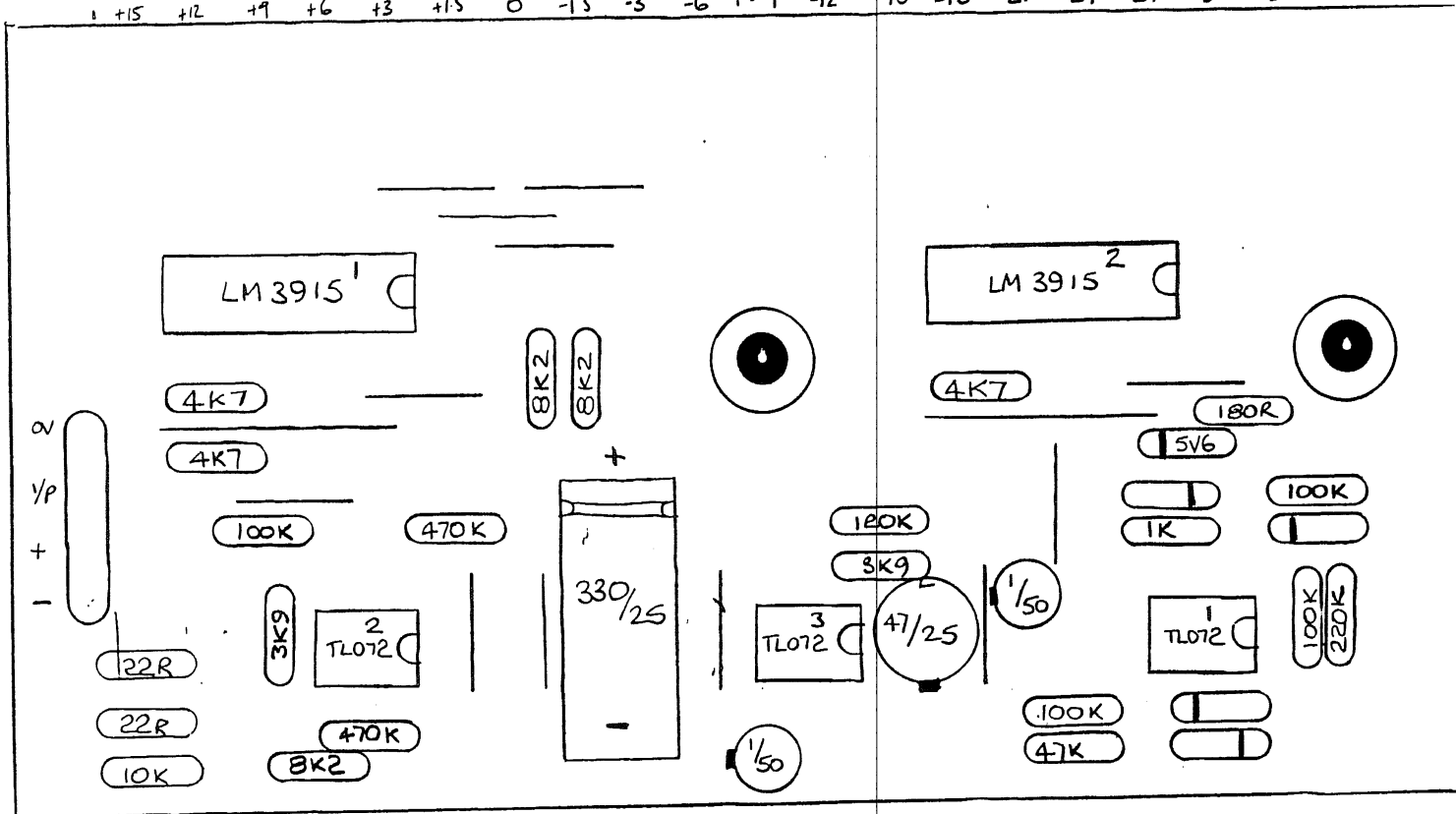

M325 MODULE, METER
PCB. AGO217 Iss 1

DRAWING NO. BW327 Iss 1

DRAWING No

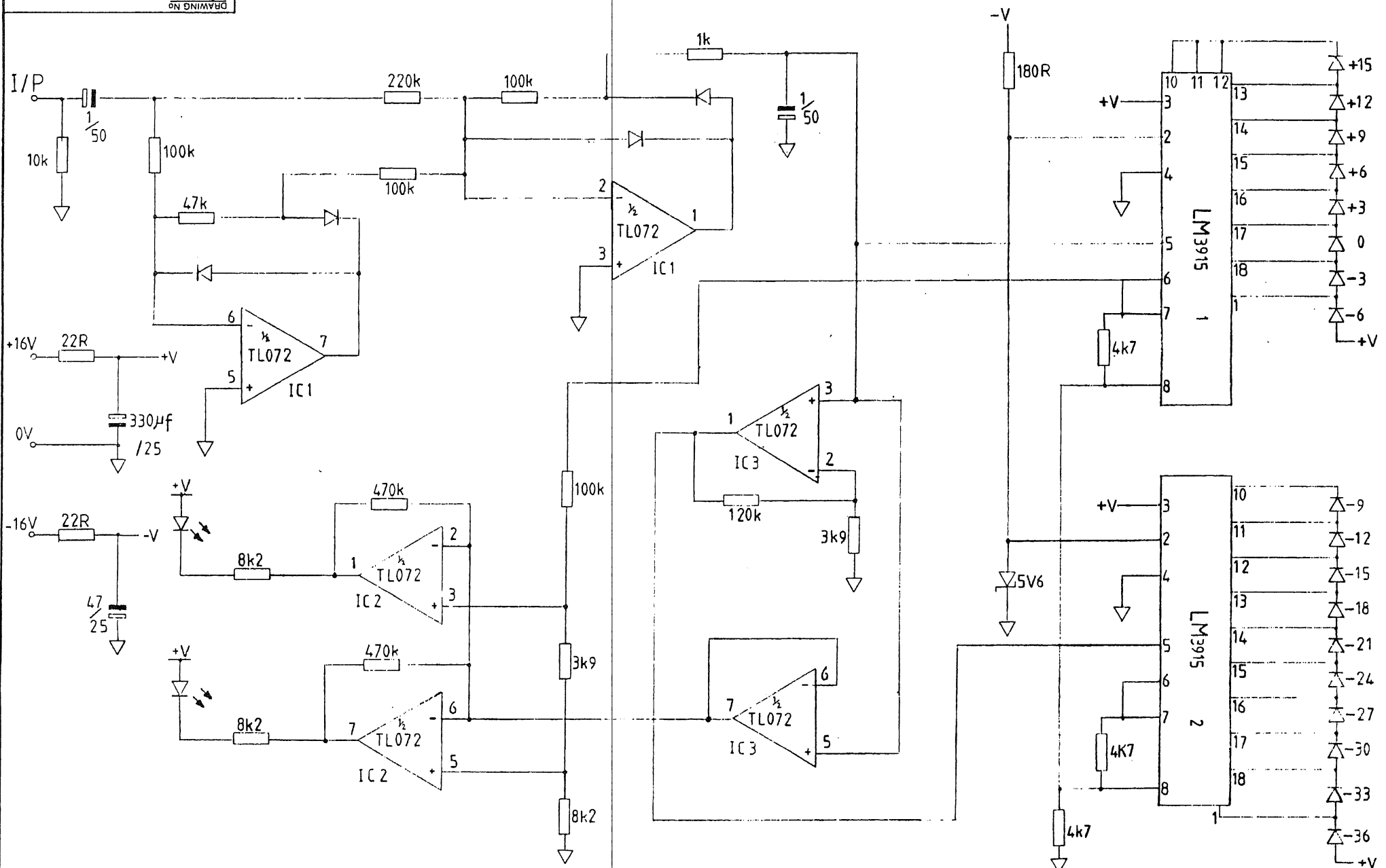

REV	DATE	BY	CHECKED

STANDARD NOTES
 ALL DIMENSIONS IN mm
 DO NOT SCALE DRAWING
 THIRD ANGLE PROJECTION
 REMOVE ALL BURRS & SHARP EDGES

SCALE

MATERIAL

TOLERANCES
 GENERAL ±0.25 mm
 HOLE CENTRES ±0.15 mm
 HOLE SIZES ±0.10 mm

UNLESS STATED OTHERWISE

FINISH

NOTES

UNIT TITLE ALLEN & HEATH
SABER M325 METER
DRAWING TITLE CIRCUIT
PCB. AGO 217

AHB ALLEN & HEATH BIRMINGHAM LTD
 PROFESSIONAL METER MANUFACTURERS

57 HIGH DEPT 99 SHIP STREET BRIMPTON OXF OX4 1LQ
 FACTORY APPROX INDUSTRIAL EST. PERWIS (OXFORD) OX1 2JH

500000 0000
DRAWING No 666 **ISSUE** 1

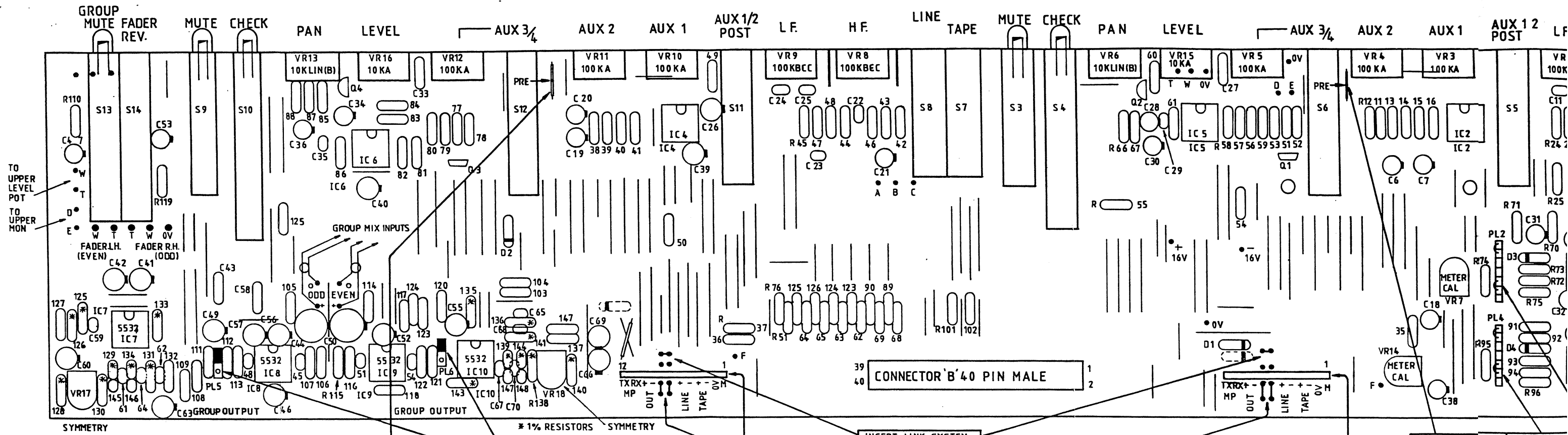

ALLEN & HEATH SABER M330
 GROUP PCB AG0201 ISSUE 3
 DRAWING NO. BW 328 ISS. 1

AUX 3/4 SUPPLIED POST FADE. LINK OPTION PRE FADE

GROUP OUTPUT LEVEL PL. 6. PL. 5. SHOWN IN HIGH +4dBu POSITION
 OPTIONAL -8dBu BY MOVING JUMPER INTO OTHER POSITION

CONNECTOR 'C' 12 PIN MALE

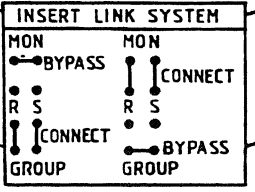

CONNECTOR 'A' 12 PIN MALE

AUX 3/4 SUPPLIED POST FADE. LINK OPTION PRE FADE

METER SHOWN IN POSITION PLUGS 2 MECHAN POSITION

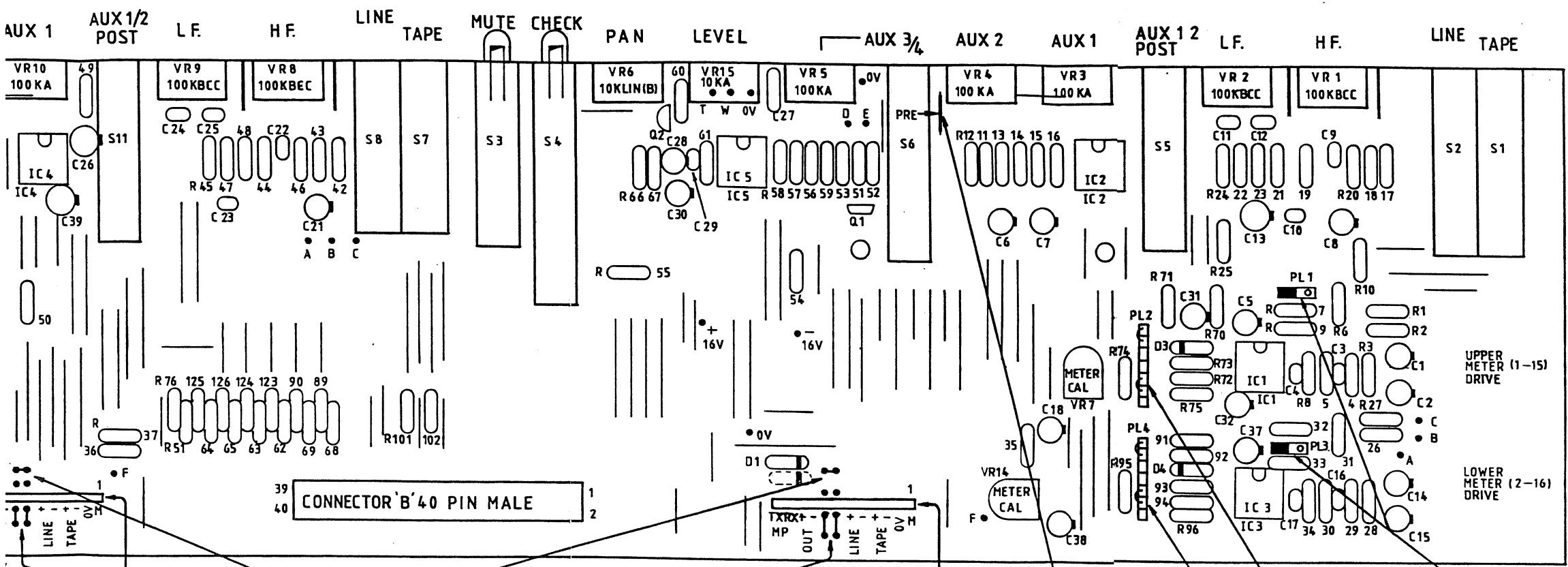

CONNECTOR 'B' 40 PIN MALE

CONNECTOR 'A' 12 PIN MALE

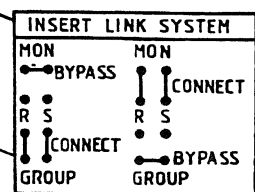

AUX 3/4 SUPPLIED POST FADE, LINK OPTION PRE FADE	METER DRIVE SELECT SHOWN IN BARGRAPHS POSITION. ROTATING PLUGS 2, AND 4 GIVES MECHANICAL METERS POSITION	MONITOR INPUT LEVEL SHOWN IN HIGH +4dBu POSITION. OPTIONAL -8dBu BY MOVING JUMPER INTO OTHER POSITION
--------------------------------------------------	----------------------------------------------------------------------------------------------------------	-------------------------------------------------------------------------------------------------------

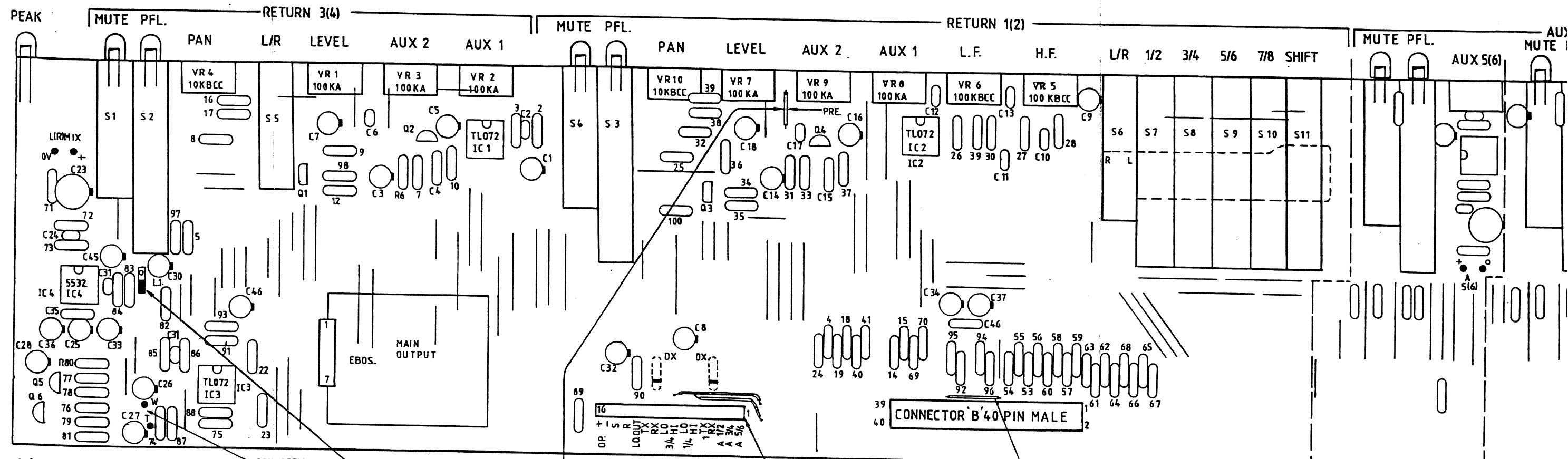

ALLEN & HEATH SABER
L (R) PCB. AG0202 ISS. 2.
PART OF M350 AND 355 MODULES

DRAWING NO. BW 329 ISS. 1

CONNECTIONS
TO MASTER
FADER

XLR OUTPUT LEVEL
L 1. SHOWN HIGH +4dBu
OPTION LOW -8dBu
REPOSITION JUMPER

RETURNS 1(2) SUPPLIED
AUX SENDS POST EQ.
AND LEVEL, OPTION PRE.

CONNECTOR 'C' 16 PIN MALE

CONNECTOR 'B' 40 PIN MALE

LINK FROM 17 TO 27 ON TRACK SIDE

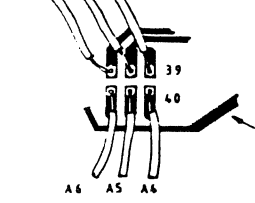

DRAWING OF TRACKSIDE OF CONNECTOR 'B' SHOWING AUX. ASSIGNMENT CABLES TO A 5(6) A 3(4)

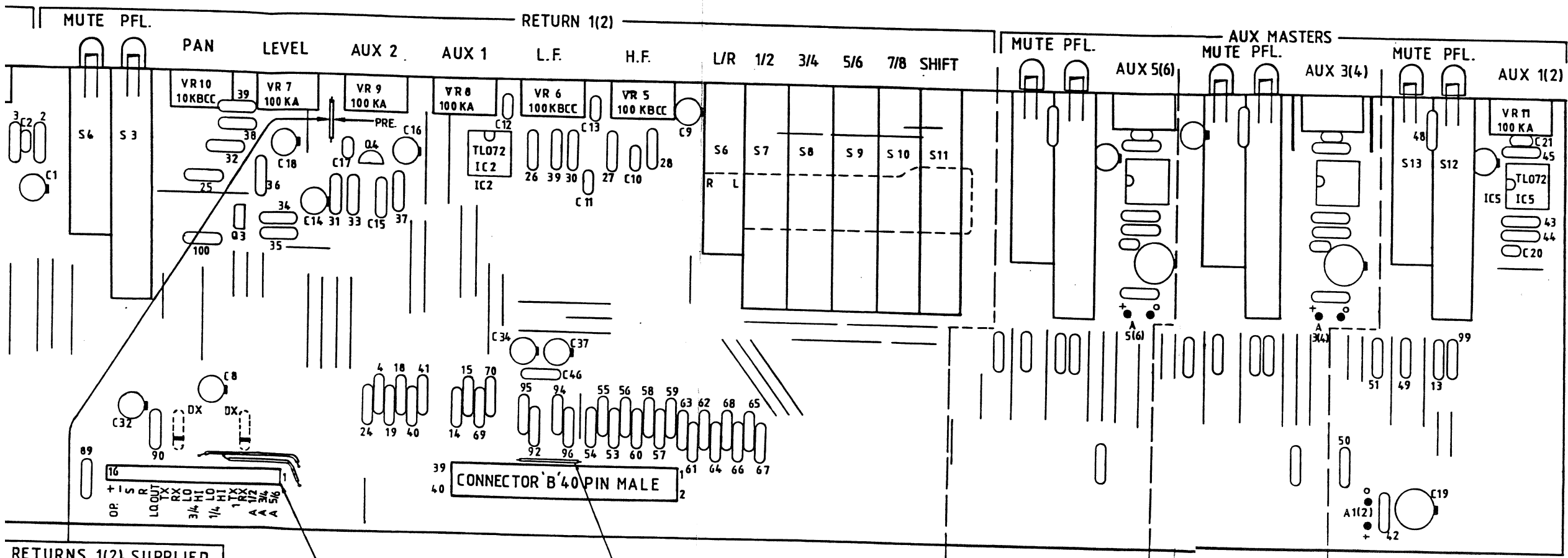

RETURNS 1(2) SUPPLIED
AUX SENDS POST EQ.
AND LEVEL, OPTION PRE.

CONNECTOR 'C' 16 PIN MALE

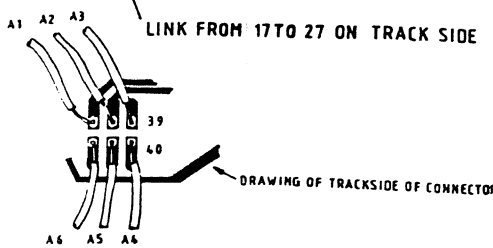

CIRCUIT REPEATED

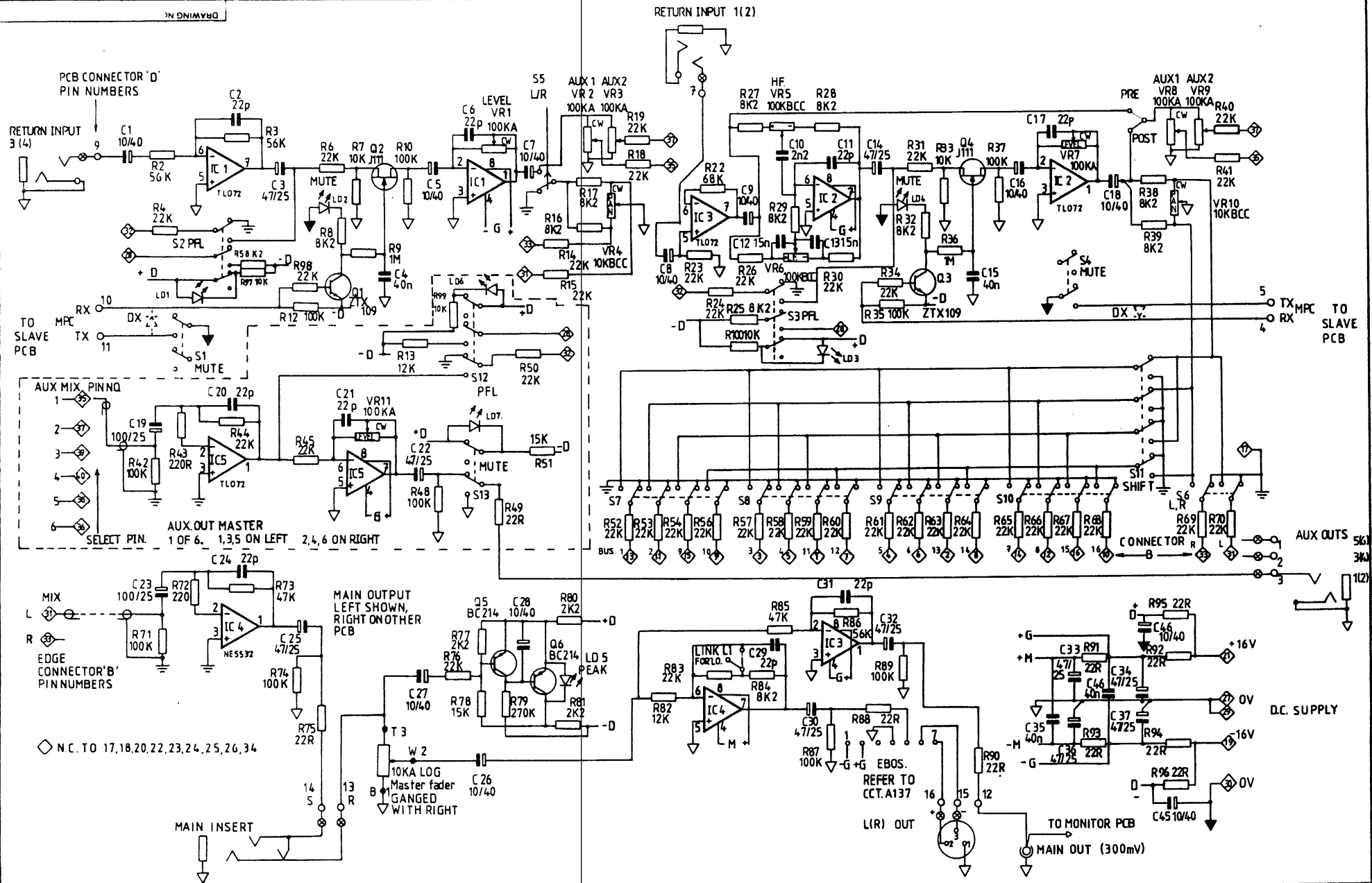

STANDARD NOTES ALL DIMENSIONS IN mm DO NOT SCALE DRAWING THIRD ANGLE PROJECTION REMOVE ALL BURRS & SHARP EDGES SCALE		MATERIAL	TOLERANCES GENERAL ±0.25 mm HOLE CENTRES ±0.15 mm HOLE SIZES ±0.10 mm	FINISH	NOTES PATCHBAY INTERFACE OPTION REFER TO COMPONENT REFERENCE SHEET	UNIT TITLE ALLEN & HEATH SABER M35Q/5 MODULE DRAWING TITLE L(R) 1 of 2 PCB AGO 202 ISSUE 2	AHB ALLEN & HEATH ELECTRONICS LTD. WATFORD, HERTS. ENGLAND TEL: 0494 414141 FAX: 0494 414142 DRAWING No. 688 Issue 1
--------------------------------------------------------------------------------------------------------------------------------------------	--	-----------------	---------------------------------------------------------------------------------------	---------------	---------------------------------------------------------------------------------	---------------------------------------------------------------------------------------------------------------	--------------------------------------------------------------------------------------------------------------------------------------

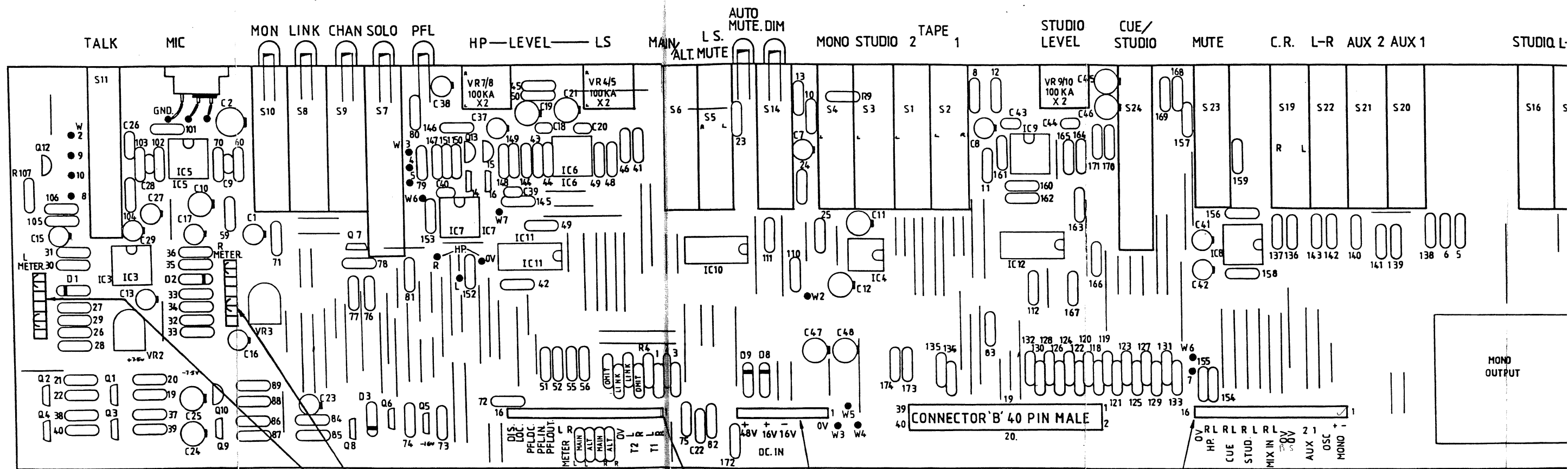

ALLEN & HEATH SABER M350
 MONITOR PCB. AG0203 ISSUE 3
 DRAWING NO. BW 330 ISS 1

METER DRIVE SELECT SHOWN
 IN BARGRAPHS POSITION.
 ROTATE PLUGS TO GIVE
 MECHANICAL METERS
 POSITION.

CONNECTOR 'D' 16 PIN MALE. CONNECTOR 'C' 5 PIN MALE

CONNECTOR 'A' 16 PIN MALE

MUTE CONTROL LOCKING DIN 5 F. 180°

PLAYBACK INPUTS SUPPLIED AS SHOWN +4dBu HIGH PB1, -8dBu LOW PB2. EITHER INPUT CAN BE +4dBu USING R1,2,3,4, OR -8dBu USING LINKS 1 OMIT 2

DC CONDITIONS WITH RESP TO 20K V. Table with columns: NOT PFL, PFL, and rows for Q & L-R, D, and D.

DC CONDITIONS WITH RESP TO 20K V. Table with columns: NOT ENABLE, ENABLE, SOLO and rows for INPUT SOLO ENABLE, PFL DC, and MONITOR SOLO ENABLE.

DC CONDITIONS WITH RESP TO 20K V. Table with columns: NEGATIVE SUPPLY, NO CHANGE, and SOLO and rows for INPUT SOLO DC and MONITOR SOLO DC.

107 -> 637

EBC EOB

214 -> 635

635 -> 214

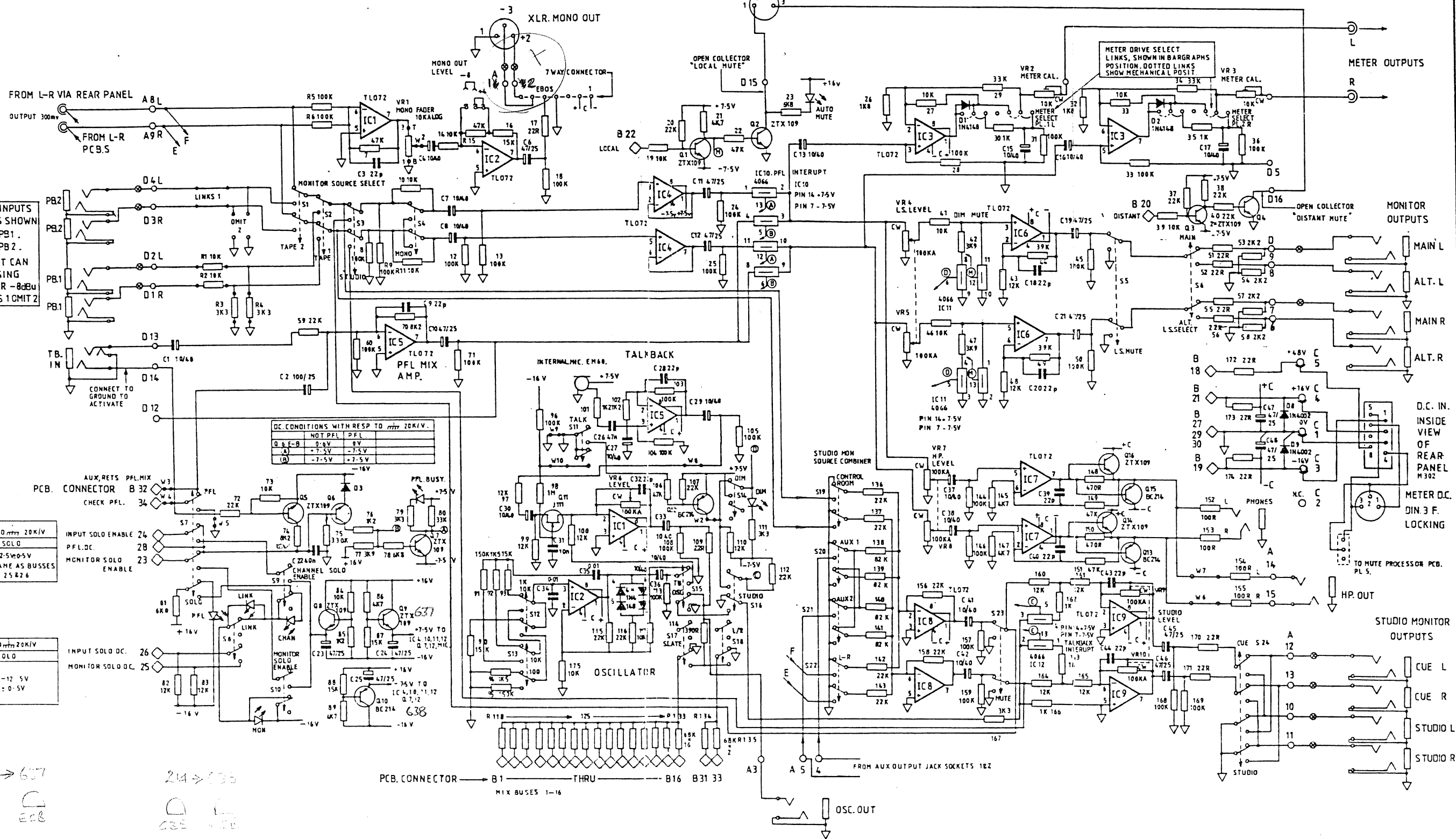

PCB CONNECTOR B1 MIX BUSES 1-16 THRU B16 B31 33

FROM AUX OUTPUT JACK SOCKETS 1B2

OSC. OUT

Production table with columns: E J, PRODUCTION, 18 189, and DATE CHECKED.

STANDARD NOTES: ALL DIMENSIONS IN mm, DO NOT SCALE DRAWING, THIRD ANGLE PROJECTION, REMOVE ALL BURRS & SHARP EDGES. SCALE

MATERIAL

TOLERANCES: GENERAL ±0.25 mm, HOLE CENTRES ±0.15 mm, HOLE SIZES ±0.10 mm. UNLESS STATED OTHERWISE

FINISH

NOTES: OPTIONAL PATCHBAY INTERFACE, REFER TO COMPONENT REFERENCE SHEET, AUTOMATED DC CONTROL LINE FROM Q1 TO IC11

UNIT TITLE: ALLEN & HEATH SABER M 350 MODULE MONITOR PCB. DRAWING TITLE: CIRCUIT DIAGRAM PCB. AGO 203 ISS. 3

AHB ALLEN & HEATH BRENNELL LTD. PROFESSIONAL AUDIO EQUIPMENT MANUFACTURERS. DESIGN DEPT. 10, SHIP STREET, BROMFORD, STAFFS. B6 7JH. TEL: 0277 34000. FACTORY: KERRICK INDUSTRIAL EST. PENNYW. CORNWALL. TEL: 0206 72070. DRAWING No. 689 Issue 1

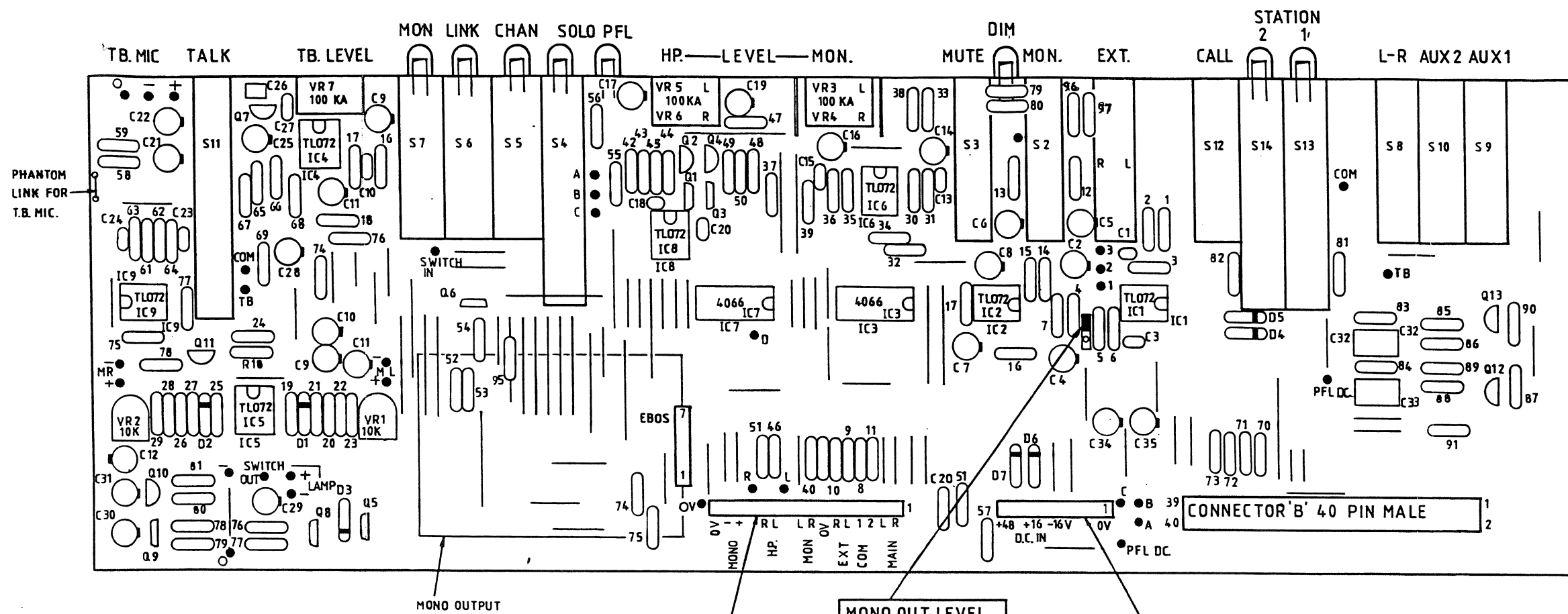

ALLEN & HEATH SABER M 355
 MONITOR PCB AG0207 ISSUE 2
 DRAWING NO. BW331 ISS. 1

MONO OUTPUT

CONNECTOR D' 16 PIN MALE

MONO OUT LEVEL
 SHOWN HIGH +4dBu,
 OPTION LOW -8dBu
 REPOSITION
 JUMPER

CONNECTOR C' 5 PIN MALE

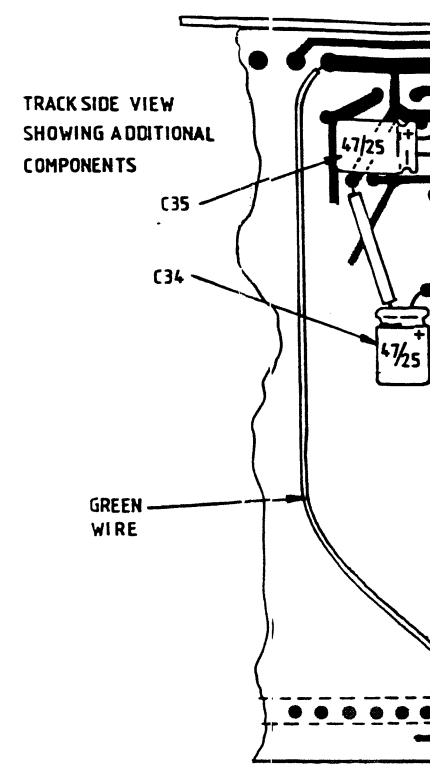

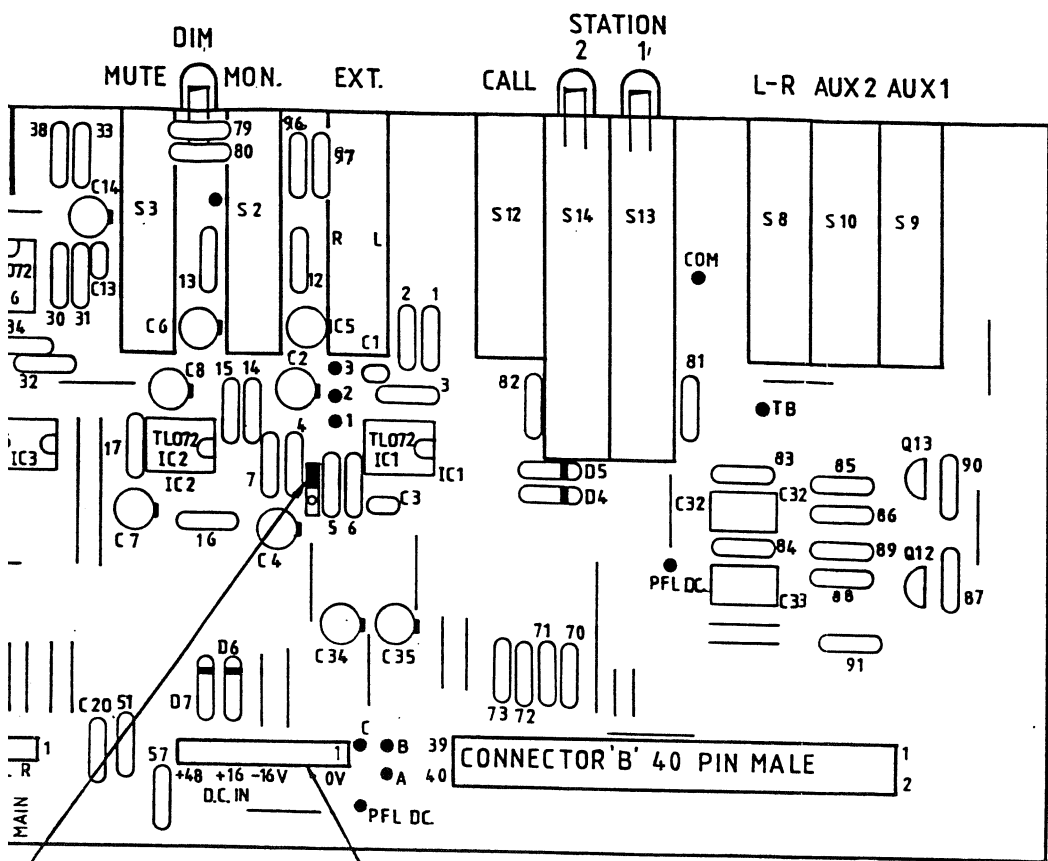

) OUT LEVEL
 VN HIGH +4dBu,
 ON LOW -8dBu
)SITION
 PER

CONNECTOR 'C' 5 PIN MALE

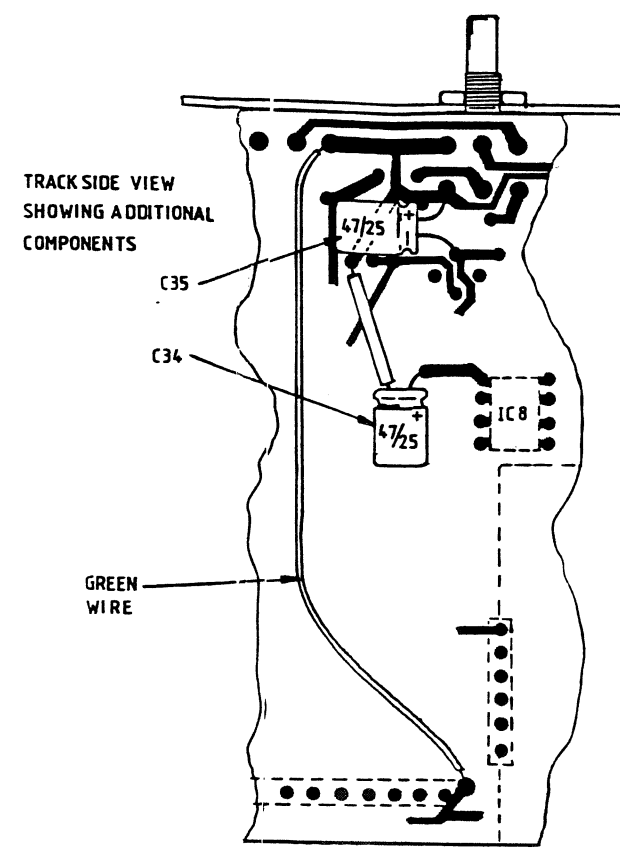

DRAWING No

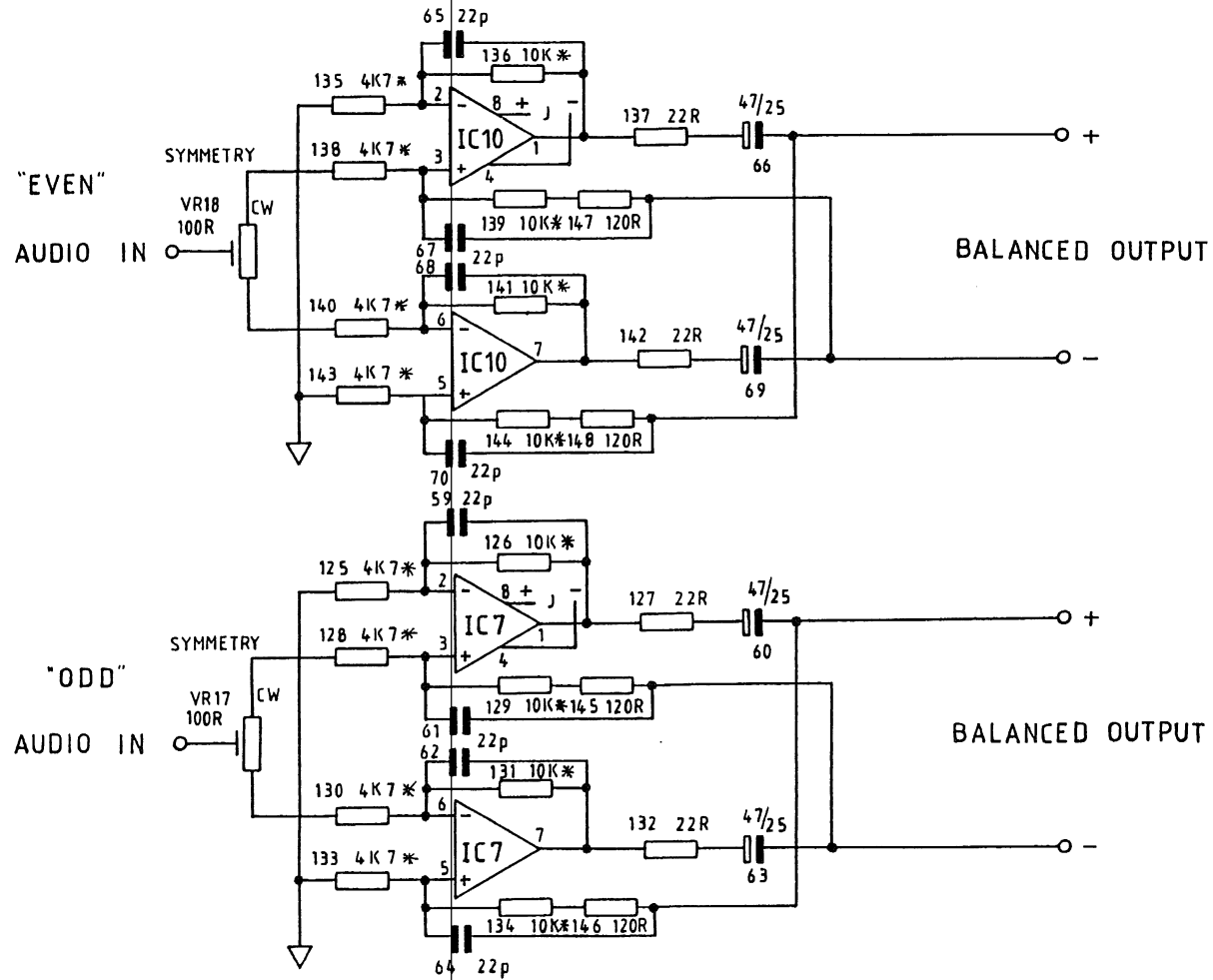

PRODUCTION	7/88	✓

STANDARD NOTES
 ALL DIMENSIONS IN mm
 DO NOT SCALE DRAWING
 THIRD ANGLE PROJECTION
 REMOVE ALL BURRS & SHARP EDGES

SCALE

MATERIAL

TOLERANCES
 GENERAL ±0.25 mm
 HOLE CENTRES ±0.15 mm
 HOLE SIZES ±0.10 mm

UNLESS STATED OTHERWISE

FINISH

NOTES
 * 1% RESISTOR
 IC.7,10 NE5532

UNIT TITLE ALLEN & HEATH
 SABER M320,325,330

DRAWING TITLE
 BALANCED OUTPUT - PART OF
 AG0201

AHB ALLEN & HEATH BRENELL LTD
 PROFESSIONAL AUDIO EQUIPMENT MANUFACTURERS

DESIGN DEPT 60 SHIP STREET BRISTOL BN1 1AB TEL 0272 24420
 FACTORY REPAIRS DEPARTMENT EST, PENYRHOE CORNWALL TR 0776 7276

DRAWING No 691 **ISSUES** 1

ARTWORKER PDS 880451

ALL RESISTORS ARE 1/4 WATT 5% UNLESS MARKED OTHERWISE

FOR LO INPUT FIT R1 IN POSITION SHOWN BY DOTTED LINE.

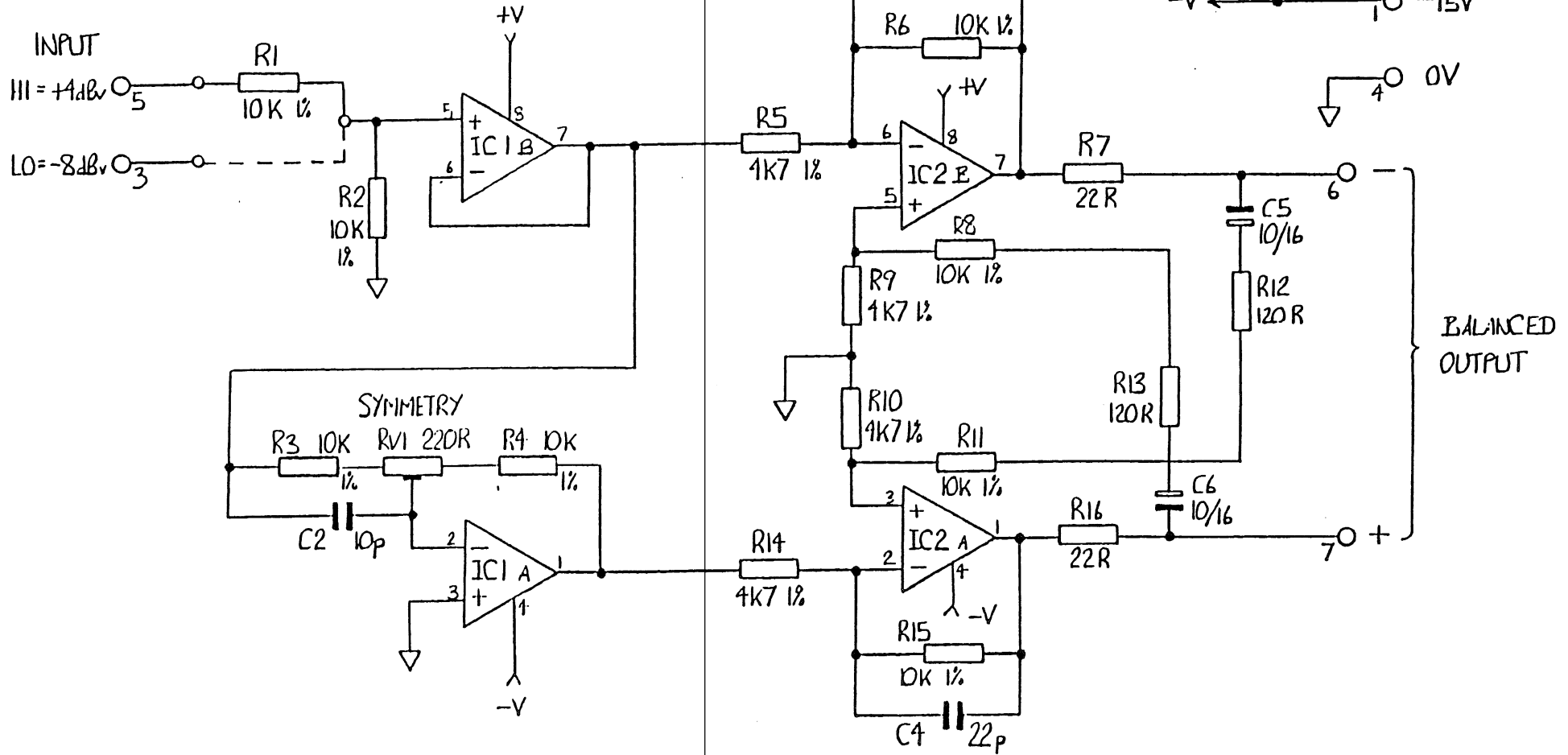

AHB

ALLEN & HEATH BRENELL LTD
PROFESSIONAL AUDIO EQUIPMENT
MANUFACTURERS

'DESIGN DEPT' BRUSH STREET, BRIGHTON BN1 1AE Tel 01273 21828
'FACTORY' KENNICK INDUSTRIAL EST, PENNYTH, CORNWALL Tel 01324 72070

DRAWING No. A137

ISSUE 2

TITLE

EBOS - OPTION PCB CIRCUITS

PCB TYPE AG0117 ISSUE 2

ELECTRONICALLY BALANCED OUTPUT SYSTEM

DRAWN BY CD 29-7-86

DRG. No.

A137 ISSUE 2

EBOS COMPONENT SIDE

AG0117 ISSUE 2

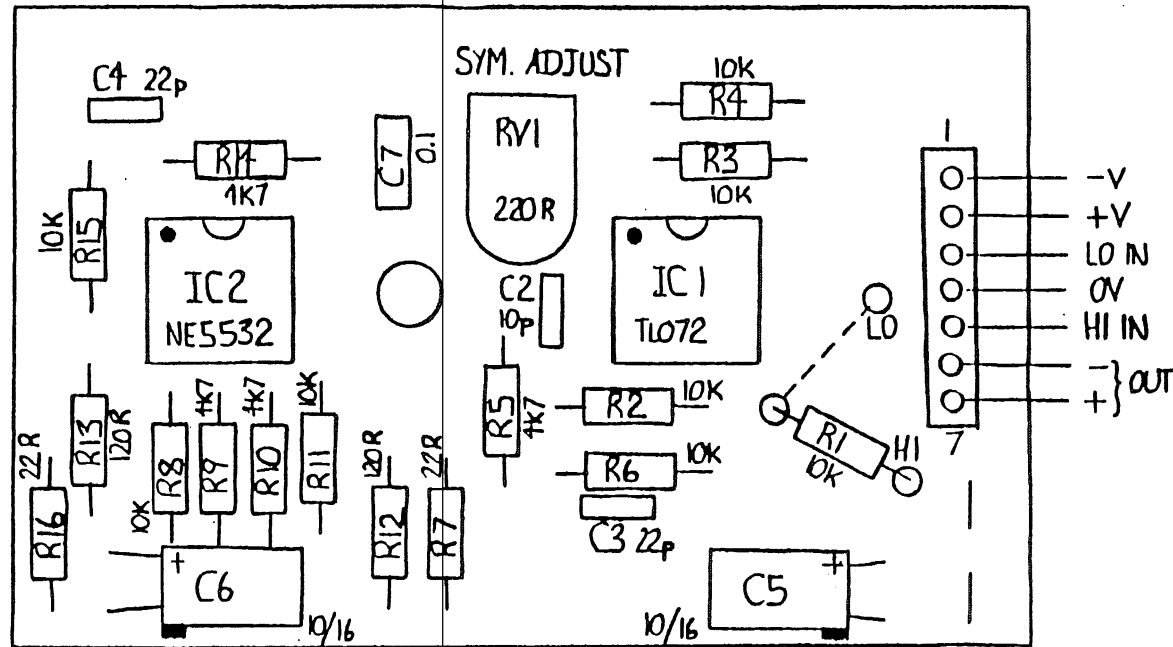

AHB

ALLEN & HEATH BRENNELL LTD.

PROFESSIONAL AUDIO EQUIPMENT
MANUFACTURERS

'DESIGN DEPT' 69, SHIP STREET, BRIGHTON BN1 1AE Tel (0273) 24928

'FACTORY' KERNICK INDUSTRIAL EST, PENRYN, CORNWALL. Tel (0326) 72070

DRAWING No.

BW 192

| ISSUE 2

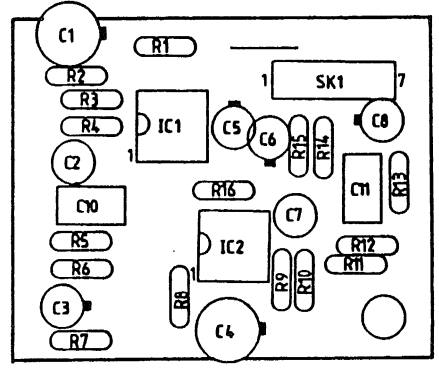
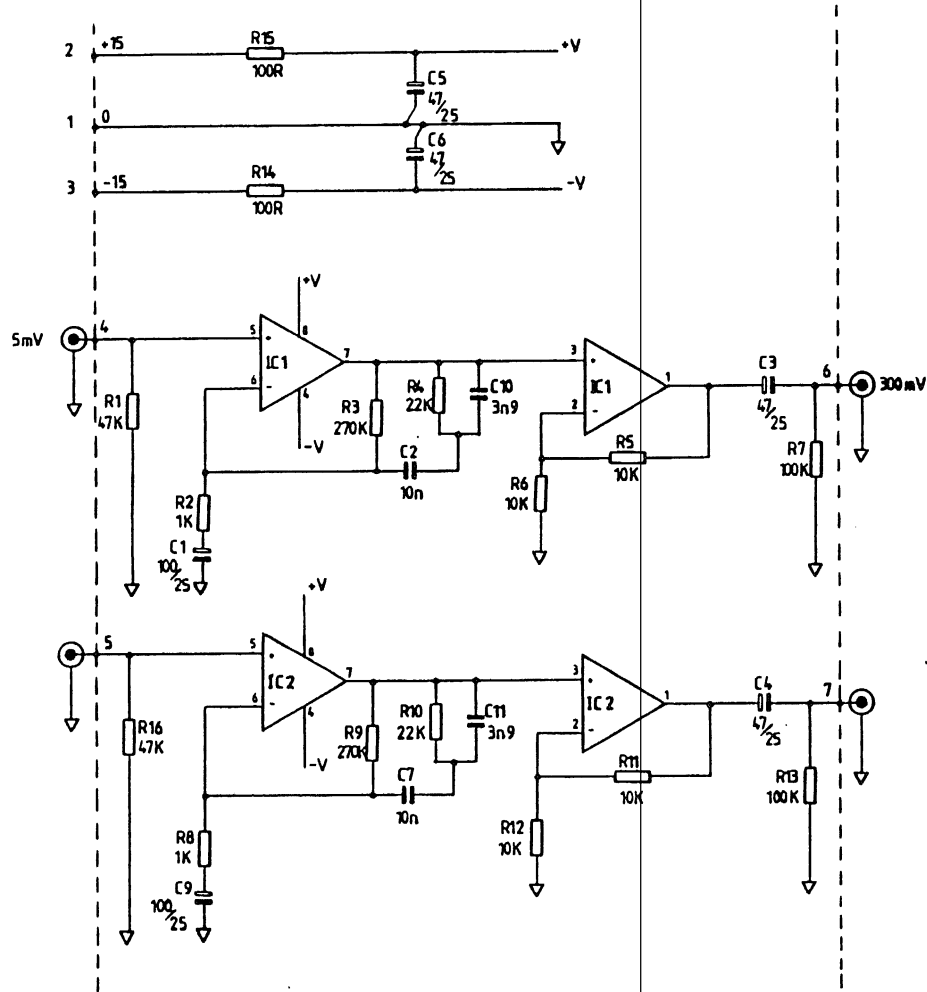

RIAA COMPONENT OVERLAY

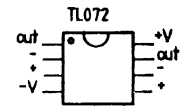

CAPACITORS SHOWN VALUE/VOLTAGE

GMR	ORIGIN	26-2-85
No.	DESCRIPTION	CHK'D APP'D DATE
ALTERATIONS		

CMC SERIES
 RIAA EQUALISED PRE-AMP
 RIAA PCB AG0102 iss 1

AHB
 69 SHIP STREET,
 BRIGHTON
 BN1 1AE
 Tel 0273 24928

DRAWN	TRACED	CHECKED	APPROVED	DATE	SCALE
GMR	KRP	TR		26-2-85	
DRAWING No. MBD111 iss 1					

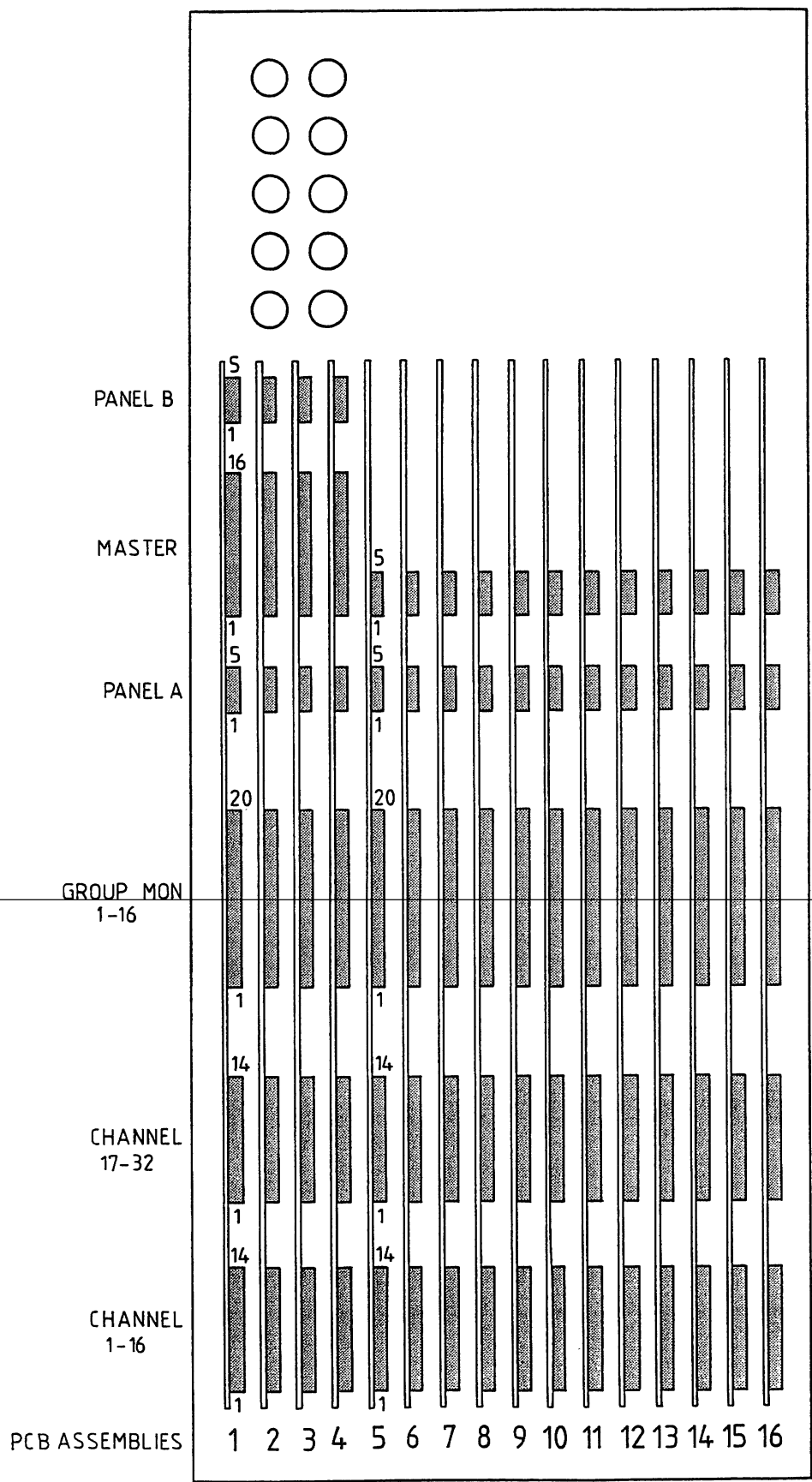

INTERNAL VIEW

SABER PATCHBAY ASSEMBLY M390 16 TRACK 32 CHANNEL

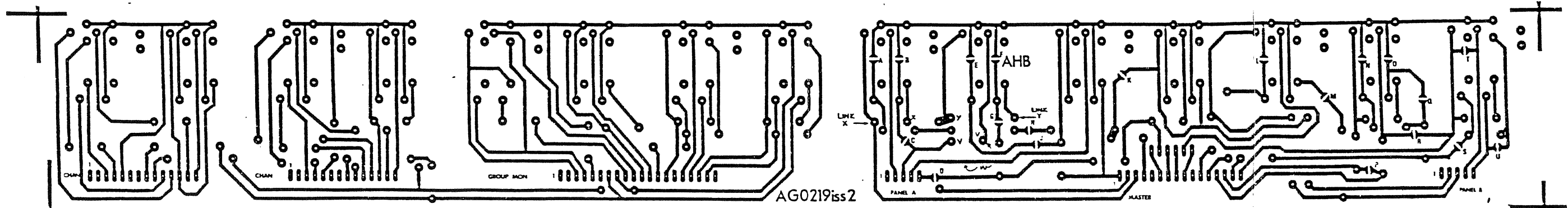

AG0219iss2

SABER PATCHBAY PCB ASSEMBLY LINK VARIATIONS SHOWN THUS  DRAWING NO. 703

<p>STANDARD NOTES</p> <p>ALL DIMENSIONS IN mm DO NOT SCALE DRAWING THIRD ANGLE PROJECTION REMOVE ALL BURRS & SWAMP EDGES</p>	<p>TOLERANCES</p> <p>GENERAL 10.25 mm HOLE CENTRES 10.15 mm HOLE SIZES 10.10 mm</p> <p>UNLESS STATED OTHERWISE</p>	<p>FINISH</p>	<p>NOTES</p> <p>PCB BOARD REF No AG0219 ISS 2 BOARD TYPE 1 FOR CH 1/17 AND L TYPE 2 FOR CH 2/18 AND R</p>	<p>UNIT TITLE</p> <p>SABER SERIES</p> <p>PATCHBAY BOARD CIRCUIT</p>	<p>DATE</p> <p>BY</p> <p>CHECKED</p>	<p>PRODUCTION</p>
----------------------------------------------------------------------------------------------------------------------------------------------	----------------------------------------------------------------------------------------------------------------------------	---------------	-------------------------------------------------------------------------------------------------------------------	---------------------------------------------------------------------	--------------------------------------	-------------------

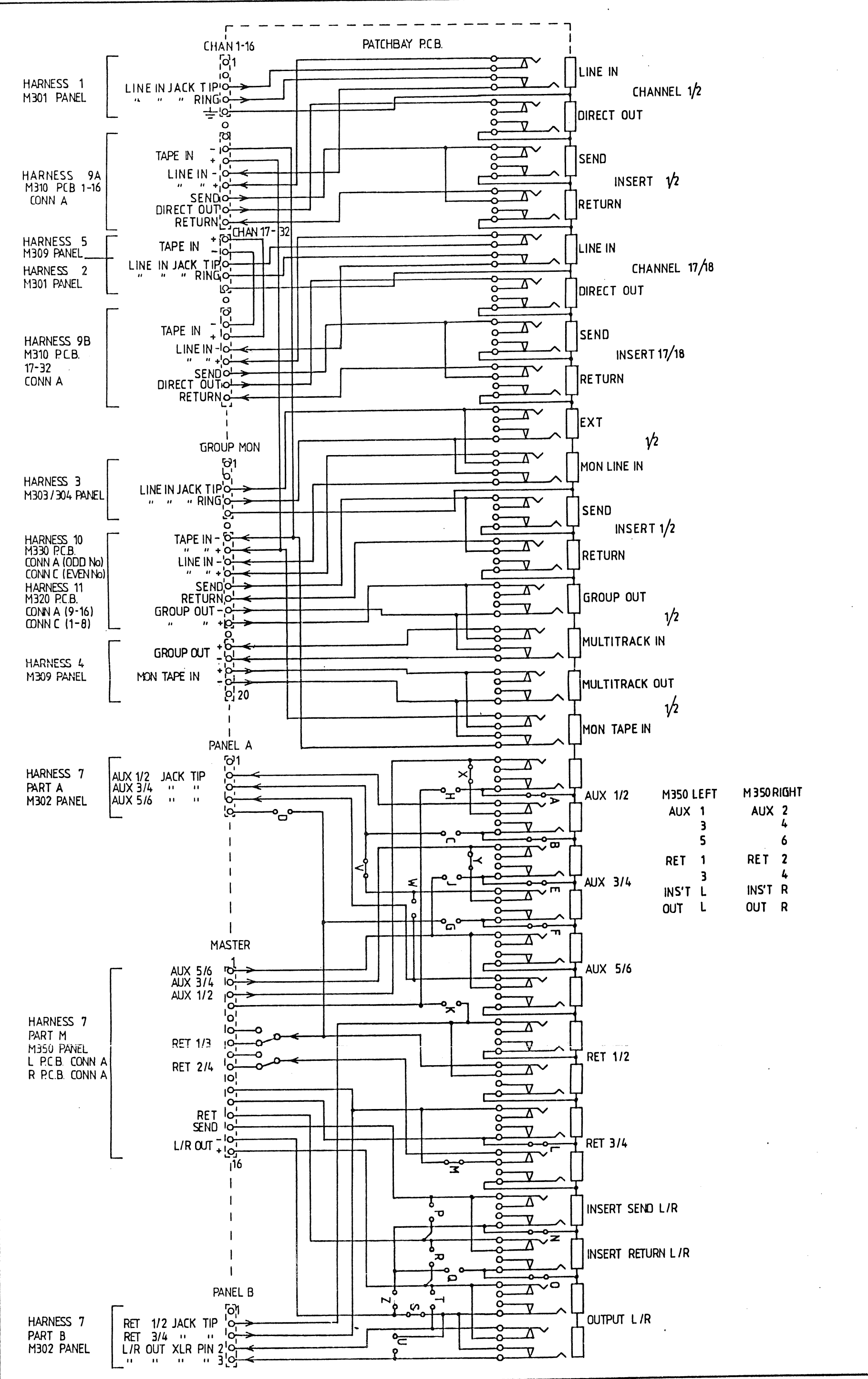

AHB
 ALLEN & HEATH BRENELL LTD
 MANUFACTURERS
 1000 WEST STREET, BIRMINGHAM B11 1JF
 TEL: 0121 425 2000
 FAX: 0121 425 2001
 DRAWING No. 681
 ISSUE 1

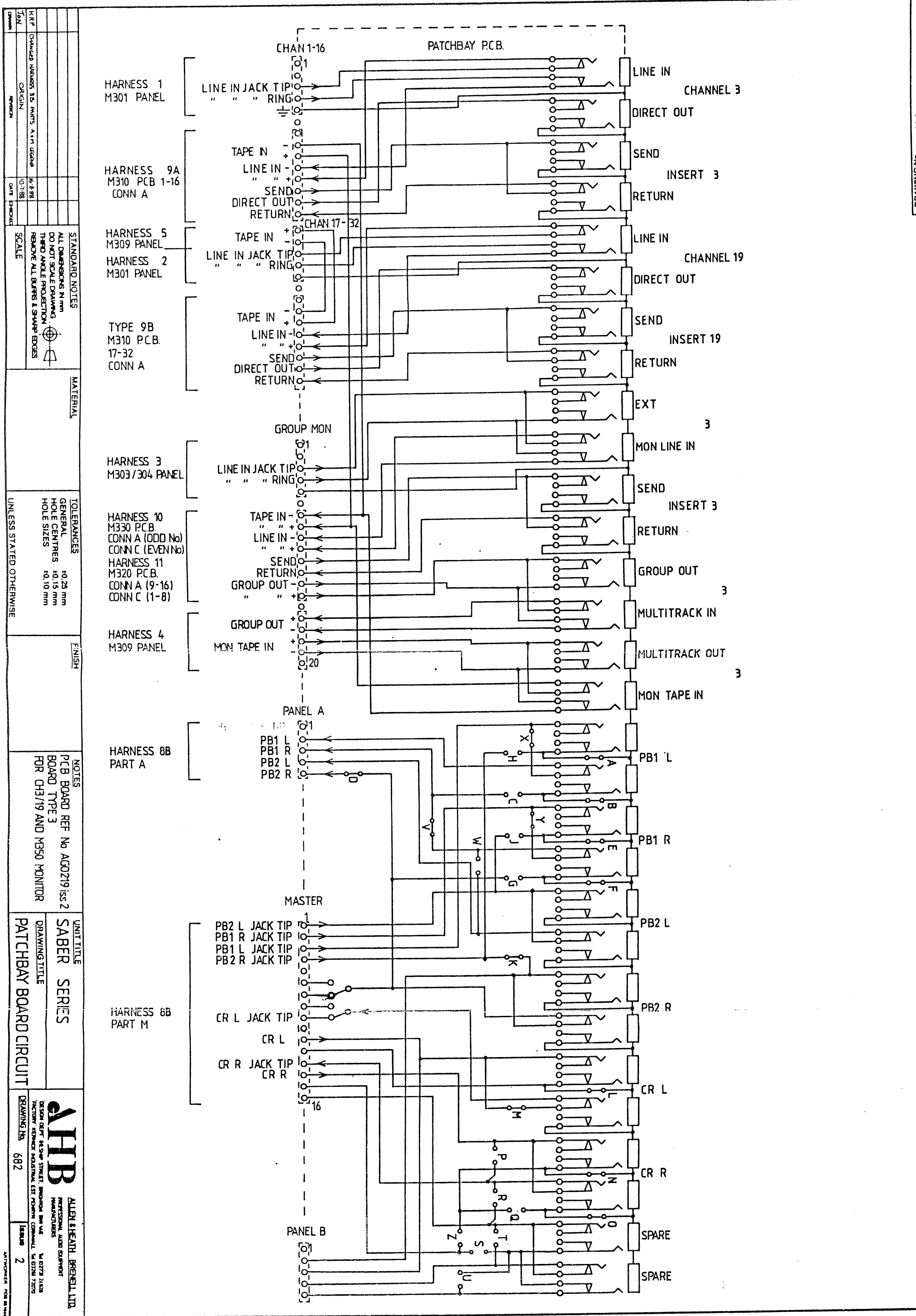

HARNESS 1
M301 PANEL

HARNESS 9A
M310 PCB 1-16
CONN A

HARNESS 5
M309 PANEL
HARNESS 2
M301 PANEL

TYPE 9B
M310 PCB
17-32
CONN A

HARNESS 3
M303/304 PANEL

HARNESS 10
M330 P.C.B.
CONN A (ODD No)
CONN C (EVEN No)
HARNESS 11
M320 P.C.B.
CONN A (9-16)
CONN C (1-8)

HARNESS 4
M309 PANEL

HARNESS 8B
PART A

HARNESS 6B
PART M

<p>STANDARD NOTES</p> <p>ALL DIMENSIONS IN mm</p> <p>DO NOT SCALE DRAWING</p> <p>THIRD ANGLE PROJECTION</p> <p>REMOVE ALL BURRS & SHARP EDGES</p>	<p>MATERIAL</p>	<p>FINISH</p>	<p>NOTES</p> <p>PCB BOARD REF No AG0219 ISS 2</p> <p>BOARD TYPE 3</p> <p>FOR CH/19 AND M50 MONITOR</p>	<p>UNIT TITLE</p> <p>SABER SERIES</p> <p>DRAWING TITLE</p> <p>PATCHBAY BOARD CIRCUIT</p>	<p>DESIGN DEPT</p> <p>FACTORY</p> <p>DESIGNING No. 682</p> <p>ISSUED 2</p>
<p>UNLESS STATED OTHERWISE</p> <p>TOLERANCES</p> <p>GENERAL +0.25 mm</p> <p>HOLE CENTRES +0.15 mm</p> <p>HOLE SIZES +0.10 mm</p>					<p>ALLEN HEATH BRENNELL LTD.</p> <p>PROFESSIONAL AUDIO EQUIPMENT MANUFACTURERS</p> <p>14 DITTON ROAD</p> <p>WIMBORNE DORSET BH20 7JN</p>

<p>STANDARD NOTES</p> <p>ALL DIMENSIONS IN mm DO NOT SCALE DRAWING THIRD ANGLE PROJECTION REMOVE ALL BURRS & SHARP EDGES</p>	<p>TOLERANCES</p> <p>GENERAL: ±0.25 mm HOLE CENTRES: ±0.15 mm HOLE SIZES: ±0.10 mm</p> <p>UNLESS STATED OTHERWISE</p>	<p>FINISH</p>	<p>NOTES</p> <p>PCB BOARD REF No AG0219 ISS 2 BOARD TYPE 4 FOR CH 4/20 AND M350 MONITOR</p>	<p>UNIT TITLE</p> <p>SABER SERIES PATCHBAY BOARD CIRCUIT</p>	<p>ALLEN & HEATH BROS. LTD. PROFESSIONAL AUDIO EQUIPMENT MANUFACTURERS DEPT. DESIG. 14, SLOAN STREET, BROMFORD, LANC. FACTORY, ROYAL INDUSTRIAL EST., FORTWYTH, CHESTER, CH1 1 2JG</p> <p>DRAWING NO. 684</p> <p>REVISED 1</p>
----------------------------------------------------------------------------------------------------------------------------------------------	-------------------------------------------------------------------------------------------------------------------------------	---------------	-----------------------------------------------------------------------------------------------------	------------------------------------------------------------------	------------------------------------------------------------------------------------------------------------------------------------------------------------------------------------------------------------------------------------------------

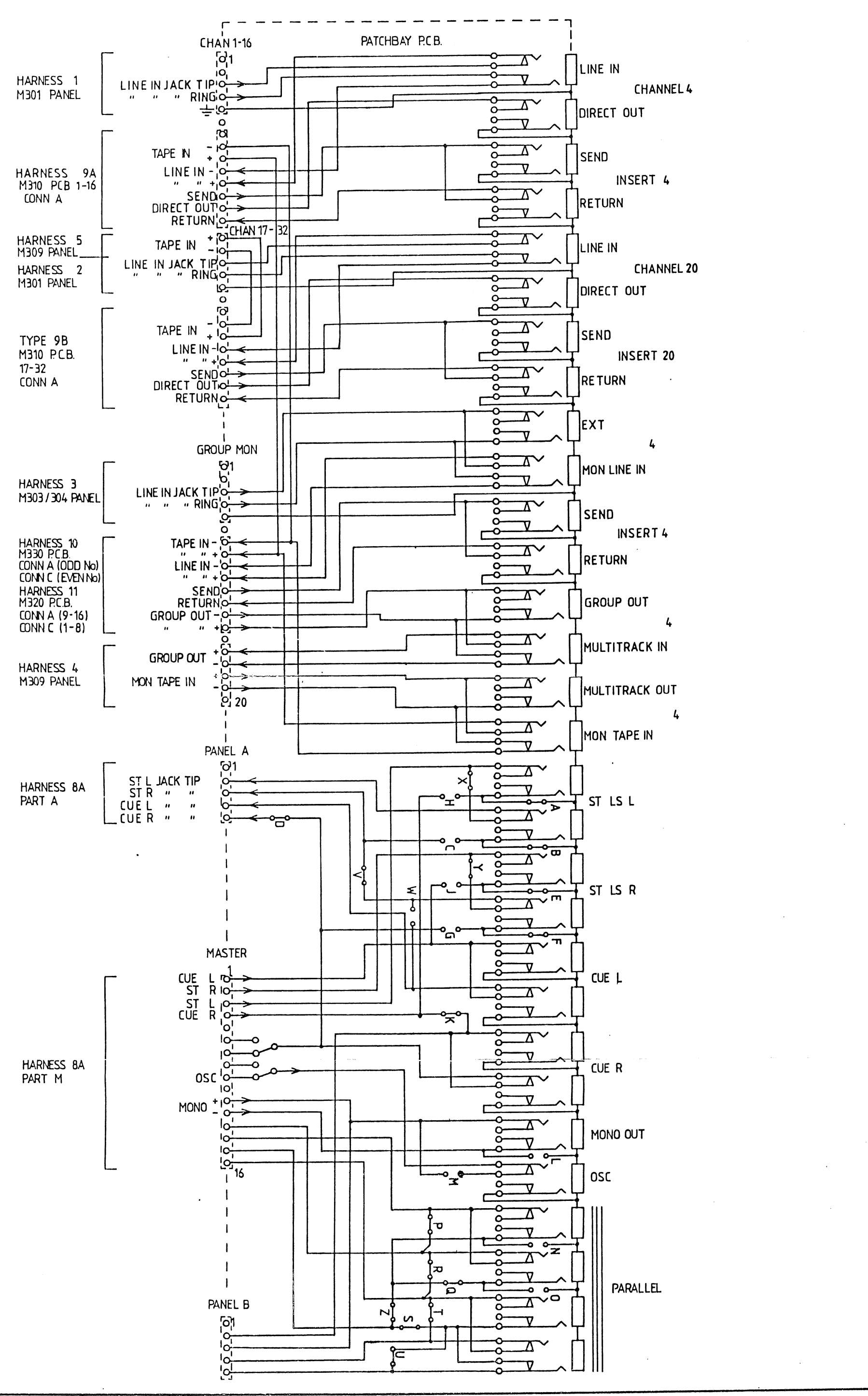

HARNESS 1
M301 PANEL

HARNESS 9A
M310 PCB 1-16
CONN A

HARNESS 5
M309 PANEL
HARNESS 2
M301 PANEL

TYPE 9B
M310 PCB
17-32
CONN A

HARNESS 3
M303/304 PANEL

HARNESS 10
M330 PCB
CONN A (ODD No)
CONN C (EVEN No)
HARNESS 11
M320 PCB
CONN A (9-16)
CONN C (1-8)

HARNESS 4
M309 PANEL

HARNESS 8A
PART A

HARNESS 8A
PART M

CHAN 1-16

PATCHBAY PCB.

CHAN 17-32

GROUP MON

PANEL A

MASTER

PANEL B

LINE IN

CHANNEL 4

DIRECT OUT

SEND

INSERT 4

RETURN

LINE IN

CHANNEL 20

DIRECT OUT

SEND

INSERT 20

RETURN

EXT

4

MON LINE IN

SEND

INSERT 4

RETURN

GROUP OUT

4

MULTITRACK IN

MULTITRACK OUT

4

MON TAPE IN

ST LS L

ST LS R

CUE L

CUE R

MONO OUT

OSC

PARALLEL