

# ALLEN & HEATH

## VISION OWNER'S MANUAL

ISSUE 1.0 JUNE 91  
For Vision Mixers Ser # C00XXX and above

<b>CONTENTS</b>		<b>PAGE</b>
<i>INTRODUCTION</i>	General Information	2
	Service & Warranty	3-5
	Electronic Performance	6
<i>PANEL CONTROL DIAGRAMS</i>		
	Input Channels	8-9
	L/R Section	10-11
	Master Section	12-13
	Rear Panel	14-15
<i>USE OF FACILITIES</i>		
FRONT PANEL CONTROLS	Input Channel	16-18
	L/R Section	19
	Master Section	20
REAR PANEL CONNECTORS	Input Channels	21
	L/R Section	21
	Master Section	22-23
<i>USER CONFIGURED OPTIONS</i>		
	Access to Mixer Circuits/Disassembly	23
	Chan Aux Sends	24
	Stereo Rtn Aux Sends	25
	Mono Output	26
	User Options Table	27
	Chassis Ground Isolation	28
<i>DIAGRAMS</i>		
SERVICE INFORMATION		
	Ribbon Connector	30
	Dimensions Diagram	31
	Block Diagram	33
SCHEMATIC DIAGRAMS		
	Input Parts and Option Placement	34
	Input Circuit Diagram	35
	L / R Parts and Option Placement	36
	L/R Circuit Diagram	37
	Master Parts and Option Placement	38
	Master Circuit Diagram	39
	Power Supply	41

## INTRODUCTION

The Allen & Heath VISION is a versatile and easy-to-use general purpose mixer intended for stereo and mono PA applications as well as stereo recording. The quality of design, construction and components employed will ensure high performance in these applications when correctly used. Operators and installers are encouraged to study the contents of this handbook.

### Construction:

1. Aluminum top panel, stove enamel, enamel silk-screened legend.
2. Steel Chassis, black stove enamel finish.
3. Individual Channel assemblies secured to Top and Rear panels.
4. Internal busbar circuits employ removable IDC harness.
5. Glass-epoxy circuits cards for strength and reliability
6. All audio path ICs are socketed for ease of service.
7. IC op-amp and discrete component circuit design.

### AC Power Requirements:

Allen & Heath power supplies MPS8-R (Supplied), MPS8-P, MPS9, and RPS-1 provide the necessary DC for the mixer and are the only power supplies recommended for use with this product. Use of power supplies other than those specified may void the mixer warranty. All Allen & Heath power supplies operate on the following mains voltages/frequencies -

220-240V AC 50/60 Hz 50VA Europe

110-120V AC 50/60 Hz USA

NOTE: The MPS-8R power supply is provided as standard, providing +15 Volts and -15 Volts for mixer operation, and +48 Volts for Phantom Power microphone operation. Though it is configured as a Rack Mount Power Supply, the 19" Panel may be removed to enable remote mounting.

Further details on mains voltages are available within the SERVICE section of this manual.

## USER SERVICE INFORMATION

There are no adjustments or alignment procedures required to maintain the performance standards of this Allen & Heath product.

To preserve the working life of the unit and its presentation, avoid the use of chemicals, abrasives and solvents. The control panel is best cleaned with a soft brush and a damp cloth. Switches and potentiometers are lubricated for life; the application of electrical lubricants to these parts is not recommended.

In the event of a failure, refer the work to your Allen & Heath Sales or Service Agent. They have the information and staff to make an effective repair, and in many cases are authorized to make repairs under warranty or give you the name of our local service agent. In the unlikely event the equipment must be returned to a service agent, always include the model and serial number and as much information as possible as to the nature of the problem. See additional information under Limited Warranty below.

A number of user options are possible. These are changes to the functions of various controls and outputs which can be modified by the user by moving internal jumpers or adding wire links. The details of these modifications are covered under the USER OPTIONS SECTION of this manual. Any modifications to the unit other than those specifically listed will automatically void the warranty on the portion of the circuit to which a modification has been performed.

## LIMITED WARRANTY

Allen & Heath warrants this product to be free from defects in materials or workmanship for a period of one year (90 days in the case of light bulbs) from the date of original purchase under normal use and maintenance conditions, and agrees to repair or, at our option, replace any defective unit at no charge for either parts or labor for the duration of the warranty period, provided that the product is returned to Allen & Heath or its authorized service station, shipping prepaid. To ensure proper validation and handling of warranty services, the prepaid warranty card enclosed must be returned to Allen & Heath within 10 days of the original purchase.

All parts and services provided during the warranty period are warranted only for the balance of the warranty period.

This warranty shall not apply if the defect or malfunction was caused by neglect, abuse, alteration, electrical currency fluctuation or accident, or damage resulting from operation not within manufacturers specification. This warranty does not cover any defect caused as a result of any repair or modification made by anyone other than Allen & Heath or its authorized service representative.

Repair or replacement as provided under this warranty is the exclusive remedy of the consumer. No other warranties are expressed or implied, including, but not limited to the implied warranties of merchantability and fitness for a particular purpose. Allen & Heath will not be liable for personal injury or property damage (unless caused solely by Allen & Heath's negligence), loss of profit or other incidental or consequential damages arising out of the use or inability to use the product.

Some States do not allow the exclusion or limitation of incidental or consequential damages, or allow limitations on how long an implied warranty lasts, so the above limitations may not apply to you. This warranty gives you specific legal rights, and you may have other legal rights that vary from State to State.

In line with our policy of continuous product improvement, Allen & Heath reserves the right to amend the design and specification of equipment without notice.

## IMPORTANT - PLEASE READ AND UNDERSTAND!

---

### EARTHING / GROUNDING

Mains electricity is dangerous and can kill. Most pieces of mains powered equipment have an earth wire running from the case to the mains plug. (Some are “double insulated” and do not need this.) This earth wire is there for safety. It is common practice in studios to disconnect some of these earth wires for sound quality reasons. This can be dangerous!

**EQUIPMENT WILL STILL WORK EVEN IF IT IS NOT EARTHED. THIS DOES NOT MEAN IT IS SAFE! GOVERNMENT AND INSURANCE UNDERWRITERS' ELECTRICAL CODES MUST BE OBSERVED. THESE CODES TAKE PRECEDENCE OVER ANY SUGGESTIONS CONTAINED IN THIS MANUAL!**

The sound quality problems mentioned are hum and interference, caused when there are several paths to earth (along the audio screens and down all the mains earths). The problem can be overcome by having just one piece of equipment connected to mains earth (usually the power amplifier).

Do not leave the earth wire loose in a mains plug as it may touch the live terminal.

Having only one item connected to mains earth means that all the others rely on the audio screen or ground for safety. It is important to remember this. Test regularly that all exposed metal gear including microphones, guitar strings and D.I. boxes have a low resistance to mains earth.

This Allen & Heath mixer case **IS NOT** connected to mains earth, for the audio reasons mentioned. The mixer is supplied with low voltage DC from the power supply; there are no hazardous voltages within the mixer case. The mixer power supply, however, **IS** connected to this third wire earth ground because there are dangerous voltages present inside the power supply. This third wire is designed to shunt to ground any voltages that may be present on the case because of a defective part. ***THIS EARTH WIRE MUST NOT BE REMOVED!***

It is best to plan ahead and have your installation checked by a competent engineer before you commence. Do not trust equipment and installations modified by others before you.

*ELECTRONIC PERFORMANCE*

0dBu = 0.776 Volts RMS 1kHz  
0VU = +4dBu = 1.23 Volts RMS  
Unreferenced dB represents Voltage Gain

MAX VOLTAGE GAIN: Figures include 10dB input fader boost

MIC IN to L/R Out	+70dB
LINE IN to L/R Out	+50dB
L/R to Mono Out	+ 6dB
INPUT PAD	-18dB
INPUT GAIN CONTROL RANGE	51dB

FREQUENCY RESPONSE:

Equalizer set to flat response or switched out 20Hz to 20kHz +0, -1dB.

INTERNAL OPERATING LEVEL: -2dBu

**ALL OUTPUTS AND INSERTS IN-PHASE REF TO XLR PIN 2 INPUT AND 1/4" TIP CONNECTOR.**

OUTPUTS: LEFT - RIGHT - MONO  
Self Compensating Electronically Balanced  
Capable of Balanced or Unbalanced operation  
Max level +27dBu Bal, +21dBu Unbal  
Recommended load 600 ohms or greater  
Connectors - 3 pin XLR Type  
Pin 1 = Gnd  
Pin 2 = +  
Pin 3 = -

When pin 2 or 3 grounded, Opposite output pin gain is increased by 6dB  
Optional transformer output available.

ALL OTHER MONO OUTPUTS  
Unbalanced; Max level +21dBu  
Recommended load 600Ω or more:  
2kΩ or more for Channel Insert  
Connector - 1/4" Phone Jack  
Tip is +, Ring and Sleeve= ground

DISTORTION:

THD typically better than 0.04%  
20Hz-20kHz at normal levels and gain settings

NOISE PERFORMANCE:

RMS noise 20kHz bandwidth

L or R Output(all input faders closed)	-87dBu
L or R Output(1 input @ unity gain)	-85dBu
Aux Outputs(Unity gain)	-92dBu
Microphone Input equivalent noise	-129dBu (200 Ω Source)
Line input pre-amp noise at 10dB gain	-85dBu

*PANEL  
DIAGRAMS*

## FRONT PANEL CONTROLS - INPUT CHANNEL

1. **GAIN**  
Adjusts the gain of the input pre-amplifier to suit various input levels. Control range is +18 to +66 (mic) and -4 to +43dB (line).
2. **LINE**  
Selects between Microphone and Line input sources. With the switch engaged, Line input is selected.
3. **PAD**  
When selected, reduces the input signal level by approximately 16dB.
4. **AUX SENDS A,B,C,D**  
Allows the operator to create up to four different mixes to be used as foldback, effects or cue mixes as desired. The VISION mixer is delivered from the factory with AUX SENDS A and B set for PRE-FADER operation. AUX SENDS C and D are set for POST-FADER operation. Internal jumpers are provided to allow custom configuration of all Aux buses.(SEE USER OPTIONS)
5. **HIGH FREQUENCY EQUALIZER**  
Boosts or cuts the High Frequencies by up to 16dB at the corner frequency of 10kHz with Shelving characteristics.
6. **MID FREQUENCY SWEEP CONTROL**  
Selects the center frequency affected by the mid frequency gain control. Continuously variable from 250Hz to 6 kHz.
7. **MID FREQUENCY EQUALIZER**  
Boost or cuts the Mid Frequency by up to 12dB. Approximately 1 octave around the center frequency with Peak/Dip characteristics
8. **LOW FREQUENCY EQUALIZER**  
Boost or cuts the Low Frequencies by up to 16dB at the corner frequency of 120Hz.
9. **EQ IN**  
With this switch engaged, the EQ section is active in the channel. With the switch released the EQ section is bypassed.

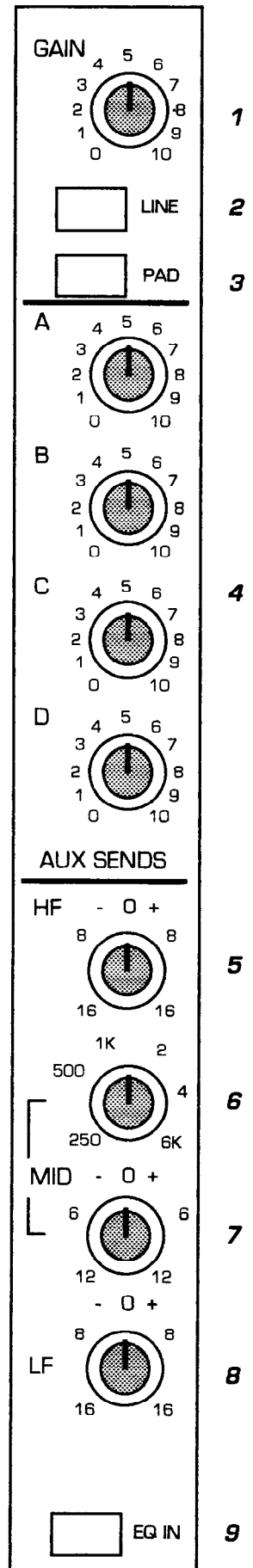



## FRONT PANEL CONTROLS - INPUT CHANNEL (CONT)

10. **PAN CONTROL**  
Positions input signal anywhere between the Left and Right outputs of the stereo mix. Full counter-clockwise routes all of the input signal to the left channel. Full clockwise routes all of the input signal to the right channel. With this control centered, an equal amount(-3dB) is routed to both the Left and Right channels
11. **MUTE SWITCH (with LED Indicator)**  
Cancels or "mutes" the channel and all of its auxiliary sends (SEE USER OPTIONS), but does not affect PFL or peak and signal present indicators. The mute LED illuminates when the channel is MUTED.
12. **PFL SWITCH**  
Allows the operator to monitor channel levels prior to the fader, regardless of fader level or channel mute status. Used with the input gain control (1) and peak indicator (15) and signal present indicator (16) to accurately set input signal levels. With PFL selected, the peak indicator(15) will come on at half intensity.
13. **PEAK INDICATOR LED (Red)**  
Illuminates 3dB before the onset of actual channel clipping and is affected by the INPUT GAIN, EQ Settings, and CHANNEL FADER settings. If any circuit is approaching overload, the LED indicator will illuminate.
14. **SIGNAL PRESENT INDICATOR (Green)**  
Illuminates when input signal in the channel is above -30dBu. Green LED indicator will vary in intensity with normal signal input variations.
15. **CHANNEL FADER**  
Controls the level of the input channel to the Left/Right and Mono outputs and any POST fader auxiliary sends. The fader marking "0" is normal operating position, indicating unity gain between input and output sections. There is an extra 10dB boost available at the fader which is obtained by raising the fader to its full up position.

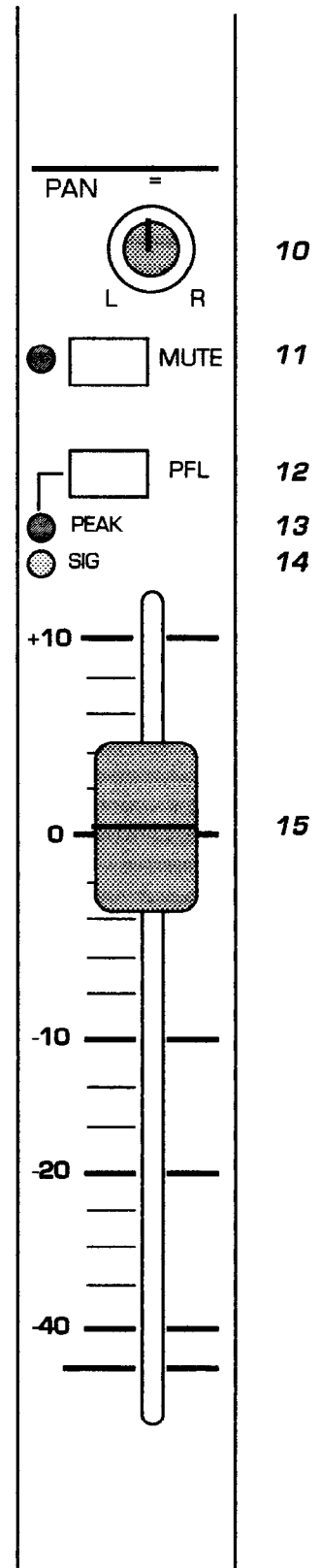

**FRONT PANEL CONTROLS**  
**LEFT/RIGHT SECTION (Left is Shown)**  
References in ( ) are for Right Master

1. **L(R) MONITOR METERS**

These multipurpose meters monitor any source selected by the Monitor section of the Master Module. When no switch is selected within the monitor section, Left and Right outputs are displayed. When any PFL switch on the mixer is engaged, these meters automatically display the signal that is present at that position. Ref level is +4dBu; range is from -21dB to +6dB with VU type response.

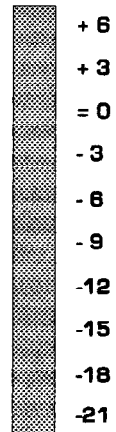

1

**MONITOR L**