

# SECTION II

## INSTALLATION

This section contains information about unpacking and inspection, equipment connectors and cabling, mounting configurations, accessory installation, initial adjustments and lubrication, and conversion for use with different tape widths and reel sizes.

### UNPACKING AND INSPECTION

Upon receipt, examine shipping crate for any signs of damage. Unpack the equipment and inspect for physical damage. Using packing list, verify that all items have been received.

#### NOTE

The plug-in electronic modules and associated equalizer printed wiring assemblies (PWA's) are mounted behind a cover on the front panel of the record/reproduce units. The power supply/bias oscillator PWA is mounted in the power supply assembly, which is located on the underside of the tape transport.

Immediately report any equipment damage and/or missing items to the transportation company and local Ampex distributor. Remove all materials (adhesive tape, rubber bands, etc.) used to secure certain movable components of the recorder/reproducer during shipment.

### CONSOLE-MOUNTED EQUIPMENT

Equipment ordered with the console is mounted and interconnected at the factory. The console is shipped lying on its back with the tape transport

located 90° to a horizontal position. To unpack the recorder/reproducer proceed as follows:

1. Open shipping container completely.
2. Check that all casters are fully inserted in the bottom of the console. Any caster that is not fully inserted might have its shaft bent when the console is set upright.
3. Place a board in front of the two rear casters of the console.
4. Grasp console vertical-support channels (Figure 2-1) and tilt console up and forward until it rests on all four casters.
5. Facing front of console, manually stabilize transport, loosen knurled knob on left inner side (facing console) of console base, rotate transport to the horizontal position, and retighten knob to secure transport in position.

### UNMOUNTED AND PORTABLE EQUIPMENT

Unmounted equipment or equipment mounted in portable cases is shipped packaged separately. Use special care in unpacking unmounted equipment to prevent damage to such critical components as the capstan, head assembly, and takeup tension arm.

### MOUNTING UNITS

Equipment ordered with the console or with portable cases is mounted in position at the factory. Unmounted equipment can be mounted in a standard 19-inch rack or in a custom cabinet. Mounting dimensions are shown in Figure 2-2. Ensure that adequate ventilation space is provided between units.

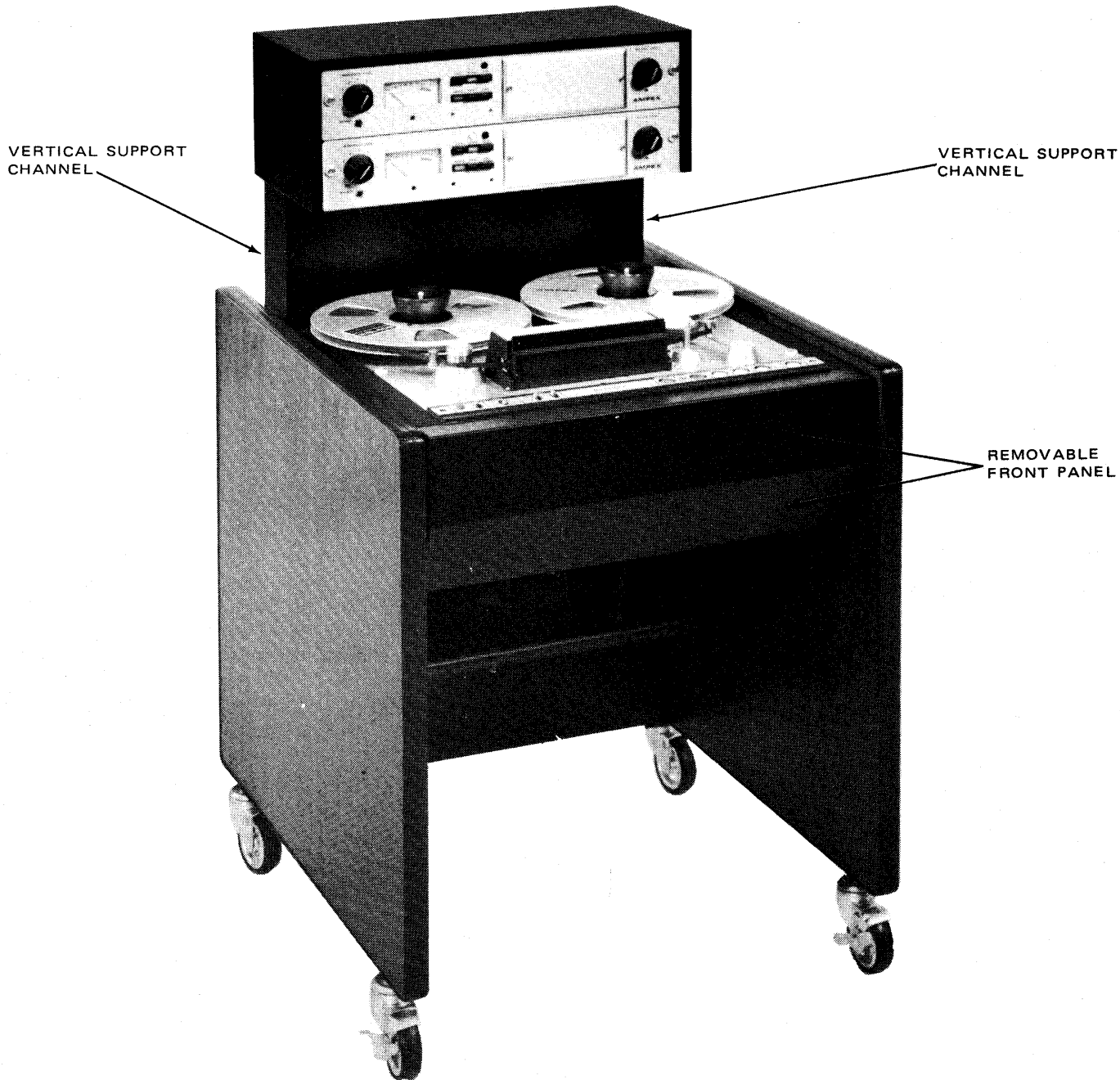

13037-3

Figure 2-1. Console-Mounted Recorder/Reproducer

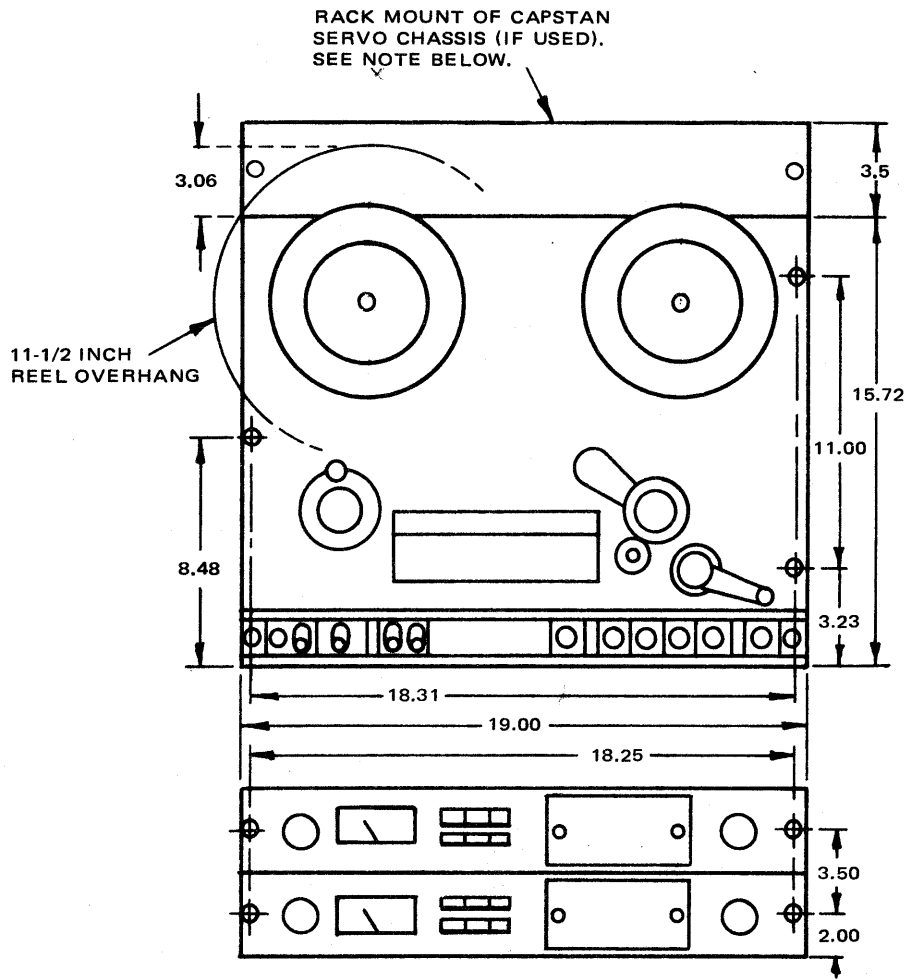

ALL DIMENSIONS IN INCHES

SPACE REQUIRED BEHIND MOUNTING (INCLUDING CONNECTORS):

TRANSPORT:	10.50 INCHES
ELECTRONICS:	9.50 INCHES

NOTE: IN A RACK MOUNT INSTALLATION, THE CAPSTAN SERVO MAY BE MOUNTED IN ANY CONVENIENT POSITION IN THE RACK. HOWEVER, BECAUSE OF HUM RADIATION FROM THE SERVO POWER TRANSFORMER, THE SERVO CHASSIS SHOULD BE MOUNTED A MINIMUM OF 3-1/2 INCHES AWAY FROM THE ELECTRONICS CHASSIS.

Figure 2-2. Mounting Dimensions

## CONSOLE FRONT-PANEL REMOVAL AND INSTALLATION

The console has a front panel (Figure 2-3) that extends down and around the bottom of the control panel. This panel must be removed to perform some installation procedures.

To remove the panel, proceed as follows:

1. Release the two captive thumbscrews at the far corners of the panel (under transport).
2. Press up on the angled portion of the panel to remove the cover lip from the transport frame slot.
3. Move the panel clear of the transport frame. Then lower the panel until the duct clears the fan (AC capstan drive motors only).

To install panel:

1. Position the duct around the drive motor fan (if equipped).
2. Insert the lip of the panel into the slot of the transport.
3. Press the lip firmly into position. Then engage and tighten the two captive thumbscrews.

## INTERCONNECTING CABLES

Equipment in a console is intercabled at the factory. However, always ensure that cable connectors are firmly seated and cables are undamaged. (Refer to paragraph on *Checking Cables and Components*.)

Portable equipment must be intercabled each time the recorder is set up in the field. Always route power and control cables as far as possible from the input/output cables and head cables to avoid electrical interference. To intercab a portable unit, proceed as follows:

1. Open rear covers of electronics case and the side panel of the transport case.
2. Remove all of the cables from the transport cable storage area.
3. Connect one of the electronic power cables (10 pin connectors) to J11 of each of the record/reproduce electronic units (Figure 1-4). Any of the power cables may be connected to any of the record/reproduce electronic units.
4. Connect the head cables (captive) to the corresponding receptacles (RECORD, ERASE, REPRO) of the record/reproduce unit(s).

### NOTE

On multi-channel equipment, the head cables are marked with the track number. The top track is designated as track 1.

## CHECKING CABLES AND COMPONENTS

Connectors on the tape transport control box are shown in Figure 2-4. Before attempting to operate the AG-440C Recorder/Reproducer, check the following cables and components for security and proper installation:

1. Captive cable from takeup motor to connector J603S on tape transport control box.
2. Captive cable from rewind motor to connector J607S on tape transport control box.
3. Captive cable from capstan drive motor to J602S on tape transport control box.
4. Captive cable from 39-Vdc power supply box on tape transport to J606S on tape transport control box.

REMOVABLE  
PANEL

CAPTIVE  
THUMB SCREW

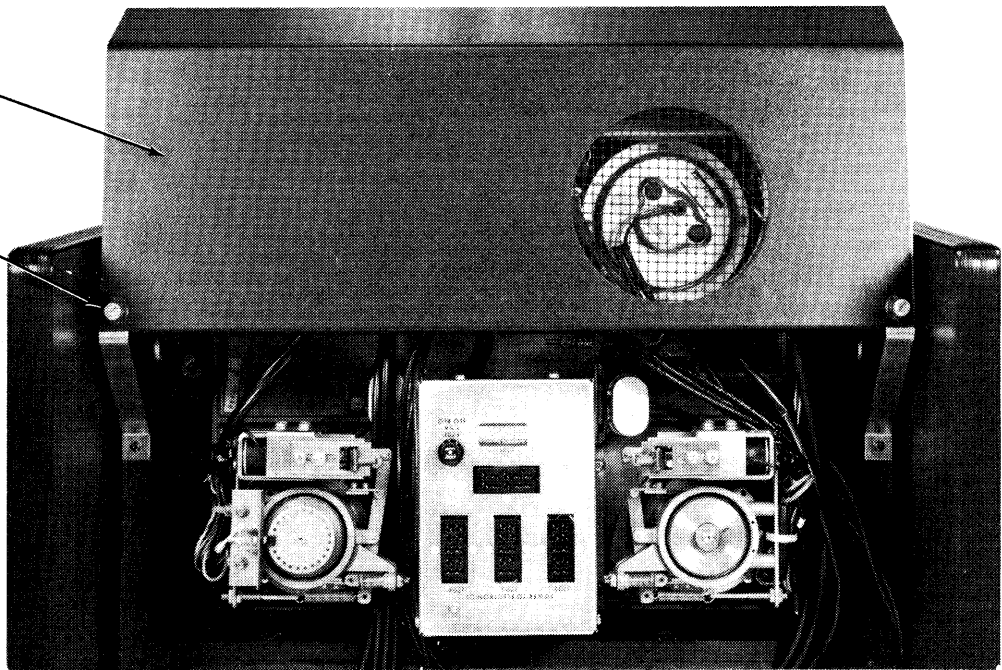

13079-2

Figure 2-3. Tape Transport Removable Panel

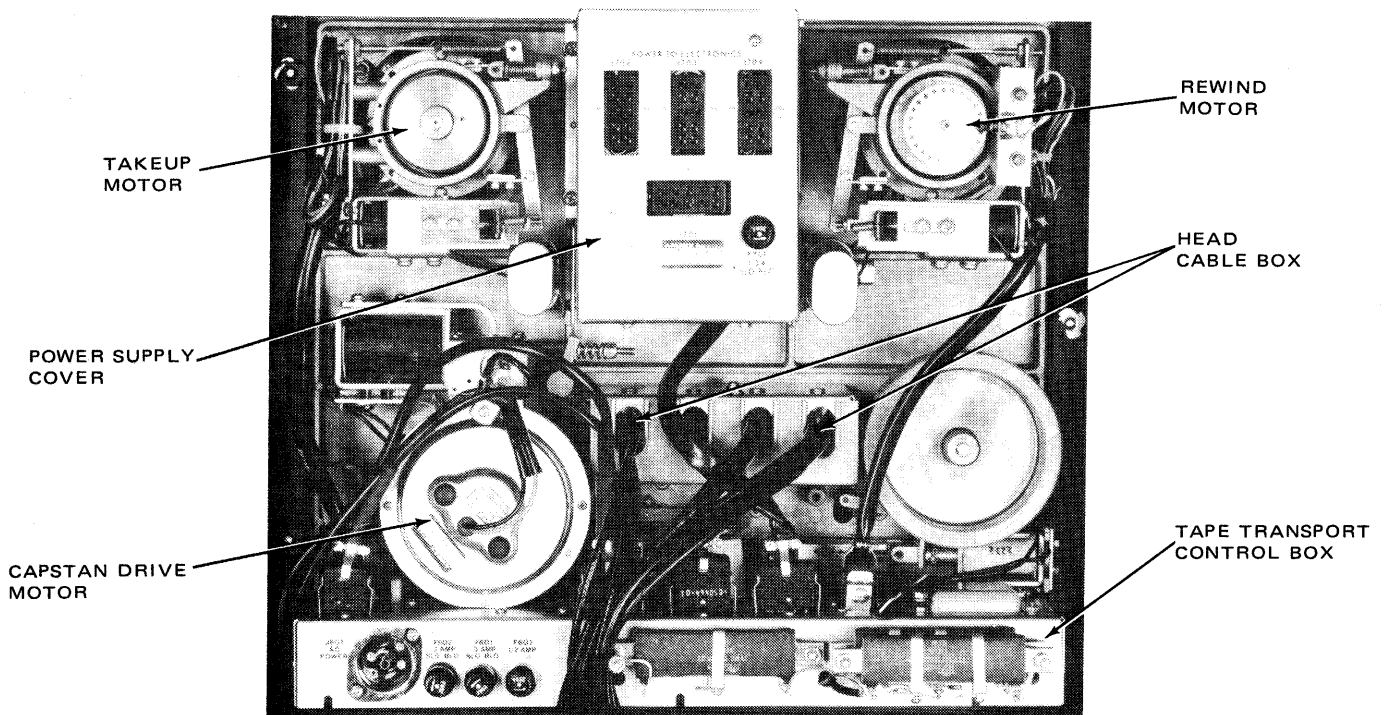

13037-19

Figure 2-4. Tape Transport (Underside View)

5. Plug-in equalizer PWA in each record amplifier module and reproduce amplifier module (Figure 2-5). Ensure that these PWA's are firmly seated in their connectors.

6. Plug-in assemblies of record/reproduce unit(s). Check that the bias amplifier, record amplifier, and reproduce amplifier modules are firmly seated in their connectors.

7. Three fuses on tape transport control box, one fuse on 39-Vdc power supply box, one fuse on rear panel of each record/reproduce unit. Verify that correct fuses are installed and serviceable.

8. Four plug-in relays on tape transport control box and one on rear panel of each record/reproduce unit.

9. 39-Vdc regulator/bias oscillator PWA (in 39-Vdc power supply box). Ensure that this PWA is firmly seated in its connector.

10. Interconnect cables from power supply box to each record/reproduce unit.

11. Head cables at each record/reproduce unit.

#### NOTE

The power-supply cover (Figure 2-4) must be opened to gain access to regulator/bias oscillator PWA.

#### INITIAL LUBRICATION

When the reproducer is first received, the AC capstan motor and the capstan idler may require lubrication. (The servo controlled DC capstan motor is permanently lubricated.)

#### AC CAPSTAN MOTOR

The AC capstan motor sleeve bearing might be dry even though there is oil in the wick reservoir. To

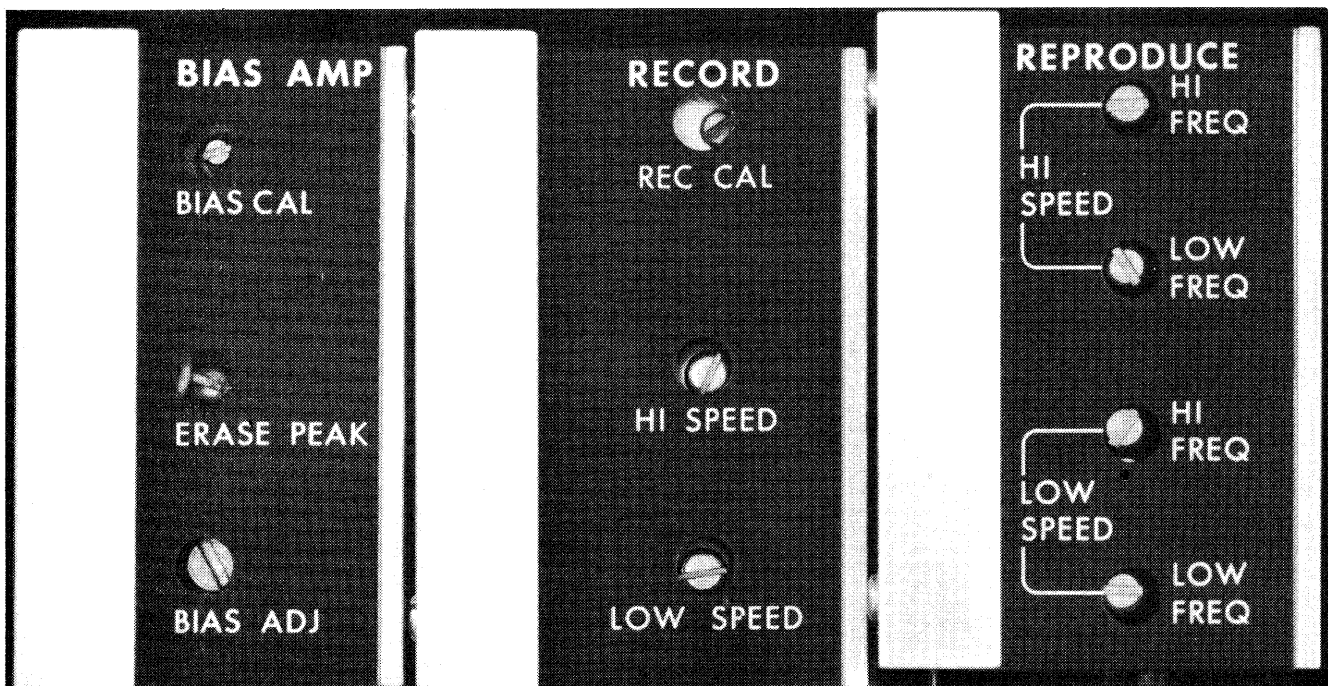

13037-15

Figure 2-5. Bias, Record, and Reproduce Modules

prevent possible damage, lubricate the bearing as follows:

1. Using a knife blade or similar tool, gently pry up the metal dust cover from around the capstan shaft (Figure 2-6).
2. Manually rotate the capstan while applying four or five drops of oil around the capstan shaft where it enters the motor. Use Ampex Lubricating Oil, Catalog No. 4010825 or 087-579. (Equivalent oils are Esso Standard Oil Co., Teresso No. 47; and Socony Mobil Co., Mobiloil DTE Medium.)
3. Wipe oil off the capstan shaft and surrounding parts. Then replace the metal dust cover.

### CAUTION

BE CERTAIN TO CLEAN CAPSTAN SHAFT THOROUGHLY. THE LUBRICATING OIL MAY DAMAGE THE CAPSTAN IDLER AND MAGNETIC TAPE.

## CAPSTAN IDLER

Check that the capstan idler has sufficient lubrication as follows:

1. Using a knife blade or similar tool, gently pry up the dust cap (Figure 2-6) from the hub of the capstan idler to expose the felt washer.
2. Apply sufficient oil to *just* saturate the felt washer. Use the same type of oil used for the AC capstan motor lubrication.

### CAUTION

REMOVE ANY EXCESS OIL FROM THE HUB OR THE CAPSTAN IDLER. IF NECESSARY, CLEAN THE IDLER WITH ISOPROPYL ALCOHOL.

3. Replace the dust cap.

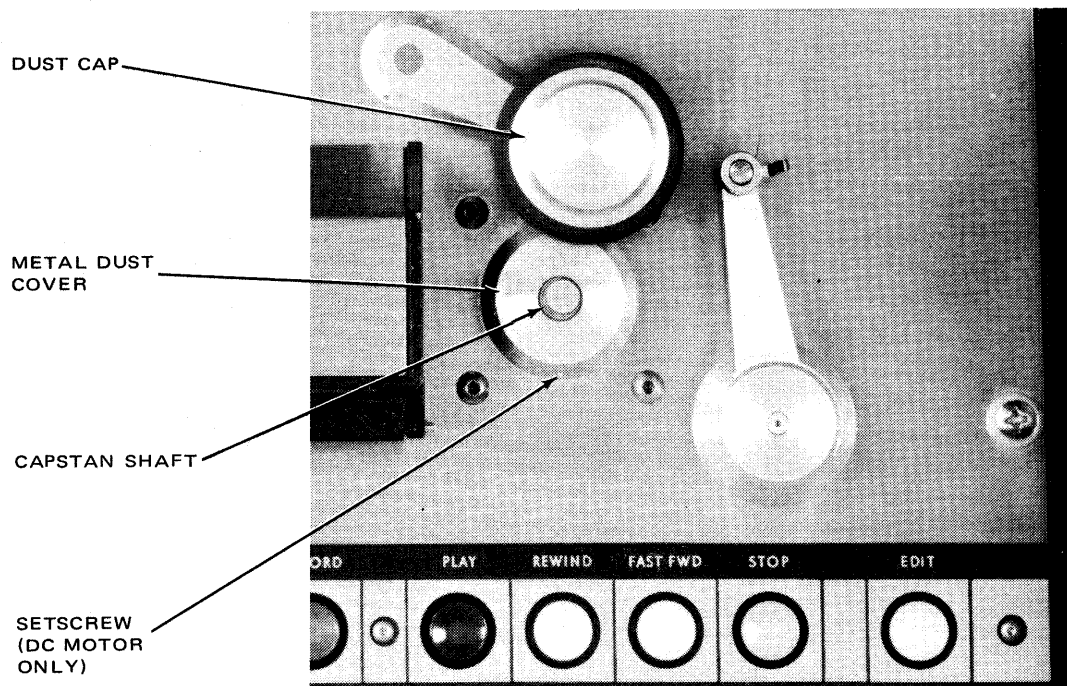

13037-16

Figure 2-6. Capstan and Associated Parts

## CONNECTING AC POWER

The power requirements of the AG-440C Recorder/Reproducer are listed in Table 1-5. To supply power to the recorder/reproducer, connect power cable between appropriate facility power source and the AC POWER connector on the tape transport control box.

## AUDIO SIGNAL CONNECTIONS

### INPUT/OUTPUT CONNECTORS

The audio signal INPUT and OUTPUT connectors of the recorder/reproducer are located on the rear panel of each record/reproduce unit. The INPUT connector is a standard female XL connector, and the OUTPUT connector is a standard male XL connector. Mating XL connectors for both the INPUT and OUTPUT rear-panel connectors are supplied with the recorder/reproducer.

#### Input-Connector Wiring

For balanced inputs, wire male XL connector as follows:

1. Connect signal leads of two-conductor shielded cable to pin 3 (high) and pin 2 (low) of connector.
2. Connect cable shield to pin 1.

For unbalanced inputs, wire male XL connector as follows:

1. Connect center conductor of single-conductor shielded cable to pin 3 of connector.
2. Connect cable shield to pins 2 and 1.

#### Output-Connector Wiring

For balanced outputs, wire female XL connector as follows:

1. Connect signal leads of two-conductor shielded cable to pin 3 (high) and pin 2 (low) of connector.

2. Connect cable shield to pin 1.

For unbalanced outputs using two-conductor shielded cable, wire female XL connector as follows:

1. Connect signal leads of cable to pin 3 (high) and pin 2 (low) of connector.
2. Connect cable shield to pin 1 of connector.
3. Connect jumper from pin 1 to pin 2 of connector.

For unbalanced outputs using single-conductor shielded cable, wire female XL connector as follows:

1. Connect center conductor cable to pin 3 of connector.
2. Connect cable shield to pin 2 of connector.
3. Connector jumper between pins 1 and 2 of connector.

### INPUT SIGNAL SETUP

The AG-440C Recorder/Reproducer is shipped with a dummy plug in the INPUT ACCESS receptacle on the back panel of each record/reproduce unit. This plug provides input impedance for an unbalanced line with a nominal impedance of 100,000 ohms. An accessory plug-in transformer must be used for balanced-line inputs. Input impedance of a record/reproduce unit using a bridging transformer is 20,000 ohms. Input impedance using a matching transformer is 600 ohms, and the voltage step up is 14 dB. A microphone preamplifier must be plugged into the INPUT ACCESS receptacle when the input signal comes from a microphone.

#### Balanced Line Inputs

Prepare recorder/reproducer for balanced-line inputs as follows:

1. Install appropriate accessory plug-in transformer in INPUT ACCESS socket on rear



panel of each record/reproduce unit requiring a balanced input.

2. Connect male connector of two-conductor shielded cable to INPUT connector on rear panel of each record/reproduce unit requiring a balanced input.

### Unbalanced Line Inputs

Prepare recorder/reproducer for unbalanced-line inputs as follows:

1. Install dummy plug-in INPUT ACCESS socket on rear panel of each record/reproduce unit requiring an unbalanced input.
2. Connect male connector of single-conductor shielded cable to INPUT connector on rear panel of each record/reproduce unit requiring an unbalanced input.

### Microphone Inputs

Prepare recorder/reproducer for microphone inputs as follows:

1. Install accessory microphone preamplifier in INPUT ACCESS socket on rear panel of each record/reproduce unit requiring a microphone input.
2. Connect microphone cable to INPUT connector on rear panel of each record/reproduce unit requiring a microphone input.

### OUTPUT SIGNAL SETUP

Prepare recorder/reproducer for balanced-line or unbalanced-line output(s) as follows:

1. Connect appropriate output cable assembly to OUTPUT connector on rear panel of each record/reproduce unit requiring an output. Refer to *Output-Connector Wiring* paragraph for information about output cables.
2. Set the LINE TERM switch of each record/reproduce unit to appropriate position. This switch should be set to OFF when the record/reproduce unit is driving loads of

600 ohms or less. Set the switch to ON for all other loads.

## ACCESSORIES

### INPUT TRANSFORMER OR MICROPHONE PREAMPLIFIER

A 600-ohm matching input transformer and a microphone preamplifier are available as optional accessories. Installation and application of these accessories are discussed in the *Input Signal Setup* paragraphs.

### REMOTE CONTROL UNIT

Except for the stop/edit and play/edit modes, all operational modes of the AG-440C Recorder/Reproducer can be controlled from a remote location with an accessory remote control unit (Catalog No. 4010080). To use this accessory, remove the dummy plug from the REMOTE CONT connector of the tape transport control box and plug the connector of the remote control unit in its place. The recorder/reproducer will not operate without a dummy plug or a remote control unit plugged into the REMOTE CONTROL connector on the tape transport control box.

### CONSOLE REAR COVERS

Rear covers for console-mounted equipment consist of a cover for the console base and individual covers for each record/reproduce unit. The optional rear covers are secured to the console back uprights by captive spring-loaded thumbscrews, which mate with threaded holes in the uprights.

### SCRAPE-FLUTTER IDLER

The scrape-flutter idler accessory (Catalog No. 4010069-02) mounts between head positions 2 and 3. This accessory is larger in diameter than the idler furnished with the recorder/reproducer and, therefore, is not interchangeable with the furnished idler. Installation instructions for the scrape-flutter idler are presented in this section.

## INITIAL ADJUSTMENTS

The AG-440C Recorder/Reproducer is set up at the factory to have the operational configuration given in Table 2-1.

Table 2-1. Factory-Shipped Operational Configuration

ITEM	SETTING
Output Impedance	600 ohms
Line Output Level	+8 dBm
LINE TERM Switch	ON
Operating Level	260 nWb/m (0 on vu meter), which is 3 dB higher than the 185 nWb/m operating level of Ampex Standard Tapes, Catalog No. 01-31325-01 for 7-1/2 in/s and 01-3135-01 for 15 in/s.
Bias and Equalization	Biased and equalized using Ampex 406 high-output, low-noise tape, Catalog No. 173111.

Some applications of the AG-440C Recorder/Reproducer require operational adjustments that differ from those established at the factory. For example, the use of conventional tape requires change of operating level, change of bias, and changing of record equalization. These changes can be accomplished using alignment procedures provided in the Maintenance section. However, if it is known that the recorder/reproducer is correctly aligned for a given set of conditions, these conditions may be changed by using the short-cut adjustment procedures presented in subsequent paragraphs.

### TEST EQUIPMENT

The only test items required to perform any of the conversion procedures presented in the following paragraphs are a sine wave signal generator (Hewlett-Packard, Model 204C or equivalent) and a suitable roll of blank tape. Refer to Table 5-1 in the Maintenance section for a complete list of required test equipment and test equipment characteristics.

If the blank recording tape to be used is a high-output, low-noise tape, a 260 nWb/m operating level is recommended. For conventional

tapes, an operating level of 185 nWb/m should be used. If the operating level adjustment of the AG-440C is in doubt, a quick verification can be made using a standard alignment tape. Simply reproduce the 185 nWb/m operating level tone, with the REPRODUCE LEVEL control set to the CAL position. If the VU meter indicates -3, the operating level is adjusted for 260 nWb/m. If the VU meter reading is 0 (zero), the operating level is 185 nWb/m.

### BIASING FOR DIFFERENT TAPE

To change the recording bias level adjustments proceed as follows:

1. Perform bias adjustment as presented in the Maintenance section of this manual (see heading *Bias Adjustment*).
2. Perform bias metering calibration adjustment as presented in the Maintenance section (see heading *Bias Metering Calibration* in Section V).

### EQUALIZING FOR A DIFFERENT TAPE

Perform the record high-frequency equalization adjustment as presented in the Maintenance section (see heading *Record High Frequency Equalization* in Section V). Readjustment of low frequency equalization is not required when changing tapes.

#### NOTE

In the short cut procedures that follow, make adjustments at the tape speed that is most commonly used.

### SHORT CUT PROCEDURES

#### Changing From 260 nWb/m To 185 nWb/m (At +8 VU Line Level)

To change operating level proceed as follows:

1. Rotate the RECORD LEVEL and REPRODUCE LEVEL controls fully counter-clockwise to CAL.
2. Press READY and INPUT pushbuttons.

3. Adjust the level of the signal generator output signal (700 Hz signal) for a 0 indication on VU meter.
4. Press READY and REPRO pushbuttons.
5. Press PLAY and then RECORD pushbuttons.
6. Use screwdriver to adjust the input level calibrate control (under RECORD LEVEL control) for a -3 indication on VU meter.
7. Use screwdriver to adjust reproduce-level calibrate control (under REPRO pushbutton) for a 0 indication on VU meter.
8. Press READY and INPUT pushbuttons.
9. Use screwdriver to adjust record calibrate control (on record plug-in module) for a 0 indication on VU meter.

#### **Changing From +8 VU To +4 VU Line Level (At 260 nWb/m Operating Level)**

To change line levels, proceed as follows:

1. Rotate the RECORD LEVEL and REPRODUCE LEVEL controls fully counter-clockwise to CAL.
2. Set METER SENSITIVITY switch to +4.
3. Press READY and INPUT pushbuttons.
4. Adjust the level of signal generator output signal (700 Hz) for a 0 indication on VU meter.
5. Press READY and REPRO pushbuttons.
6. Press PLAY and then RECORD pushbuttons.
7. Adjust RECORD LEVEL control for a 0 indication on VU meter.
8. Use screwdriver to adjust reproduce-level calibrate control (under REPRO pushbutton) for a -4 indication on VU meter.
9. Return RECORD LEVEL control to CAL position.

10. Use screwdriver to adjust the input calibrate adjustment (under RECORD LEVEL control) for a 0 indication on VU meter.
11. Press READY and INPUT pushbuttons.
12. Use screwdriver to adjust record-level calibrate control (on record plug-in module) for a 0 indication on VU meter.

#### **Changing From +8 VU To +4 VU Line Level and From 260 nWb/m To 185 nWb/m Operating Level**

To change levels, proceed as follows:

1. Rotate the RECORD LEVEL and REPRODUCE LEVEL controls fully counter-clockwise to CAL.
2. Set METER SENSITIVITY switch to +4.
3. Press READY and INPUT pushbuttons.
4. Adjust the level of signal generator output signal (700 Hz) for a 0 indication on VU meter.
5. Press READY and REPRO pushbuttons.
6. Press PLAY and then RECORD pushbuttons.
7. Adjust RECORD LEVEL control to obtain a 0 indication on VU meter.
8. Use screwdriver to adjust reproduce-level calibrate control (under REPRO pushbutton) to obtain a -1 indication on VU meter.
9. Return the RECORD LEVEL control to CAL position.
10. Use screwdriver to adjust the input level calibrate control (under RECORD LEVEL control) for a 0 indication on VU meter.
11. Press READY and INPUT pushbuttons.
12. Use screwdriver to adjust record calibration control (on record plug-in module) for a 0 indication on VU meter.

## Changing From Nominal (600-Ohm To 150-Ohm) Output Impedance

To change output impedance proceed as follows:

1. Rotate the RECORD LEVEL and REPRODUCE LEVEL controls fully counter-clockwise to CAL.
2. Connect the load that will normally be used with the recorder/reproducer to the audio OUTPUT connector of desired record/reproduce unit.

### NOTE

The LINE TERM switch on each record/reproduce unit can be used to connect a 680-ohm load across the audio output of the unit. To connect the 680-ohm load, set the LINE TERM switch to ON.

3. Press READY and REPRO pushbuttons.
4. Press PLAY and RECORD pushbuttons.
5. Adjust the level of signal generator output signal (700 Hz) for a 0 indication on VU meter.
6. Set OUTPUT impedance switch to 150.
7. Use screwdriver to adjust reproduce-level calibrate control (under REPRO pushbutton) for a 0 indication on the VU meter.
8. Press READY and INPUT pushbuttons.
9. Use screwdriver to adjust record calibrate control (on record plug-in module) for a 0 indication on VU meter.

### VERIFICATION OF OPERATING LEVEL USING TAPE SATURATION

Tape-saturation testing may be used to check the results of the procedures concerned with changing the operating levels. For a conventional tape, the maximum level of a 700-Hz signal at 15 in/s is

about 12 to 14 dB above the normal 185 nWb/m output. For a high output tape, the saturation normally occurs 12 to 14 dB above the 260 nWb/m output. The 20% index on the VU meter may be used as a rough indication of a signal 14 dB below 0 VU.

To verify operating level, proceed as follows:

1. Rotate the RECORD LEVEL and REPRODUCE LEVEL controls fully counter-clockwise to CAL.
2. Press READY and REPRO pushbuttons.
3. Press PLAY and then RECORD pushbuttons.
4. Adjust output signal level of signal generator to obtain a 0-VU indication on VU meter (at 700 Hz for 15 in/s or 350 Hz for 7-1/2 in/s).
5. Adjust REPRODUCE LEVEL control to obtain a 20% indication on VU meter.
6. Turn RECORD LEVEL control clockwise until a maximum VU indication is obtained. There is no gross operating-level error if the VU indication is between -3 and 0. If the zero-adjust setting of the VU meter is inaccurate, the 20% mark can be in error.

### CONVERSION

#### TURNTABLE REPOSITIONING FOR DIFFERENT REEL SIZE

The takeup and rewind assemblies, including turntables, are secured to the reel guards through slots in the top plate. These slots permit the takeup and rewind assemblies to be adjusted to accommodate different size reels. Before the AG-440C Recorder/Reproducer is shipped from the factory, the takeup and rewind assemblies are positioned as close together near the center of the transport as possible. This position of the assemblies allows the use of reels up to 10-1/2 inches in diameter. If 11-1/2 inch CCIR reels are to be used, the assemblies can be repositioned as follows.

## NOTE

When the takeup and rewind assemblies are positioned to accommodate 11-1/2 inch CCIR reels, transports cannot be mounted side-by-side on standard 19-inch racks because the reels protrude beyond the edges of the racks.

1. At the rear of the transport, loosen the three self-locking nuts that secure the takeup assembly to the reel guard. Then, loosen the three self-locking nuts that secure the supply assembly to the reel guard.
2. Slide the takeup and rewind assemblies as far as possible from the center of the transport.
3. Verify that the reel-guard flats are parallel to the top edge of the transport and that the turntables are centered in the guards. Then, tighten the six nuts loosened in step 1.

## TAPE-WIDTH CONVERSION

Setting up the tape transport to accommodate 1/2-inch or 1/4-inch tape is accomplished by rotating two tape guides in their mountings and changing head assemblies. One guide is located on the reel idler and the other is located on the takeup tension arm. Head alignment of the replacement head assembly must be performed (see Maintenance section).

## Rotating Tape Guides

To rotate the tape guides to accommodate different tape widths, proceed as follows:

1. Lift the reel-idler guide against the spring pressure and turn it until the desired-size guide is in the tape path.
2. While supporting the takeup tension arm to prevent bending, lift the tension arm guide against the spring pressure and turn the guide to the desired guide width in the tape path.

## NOTE

The guides snap down into position when correctly aligned.

## Changing Heads

To remove head assembly, proceed as follows:

1. Loosen the captive screw on the slanted rear surface of the head assembly. Then, remove the stainless steel head cover.

## NOTE

For a four-position head, the switching knob must be unscrewed to free the cover. The switching knob is located at the center of the head cover.

2. Disconnect all head connectors carefully (Figure 2-7).

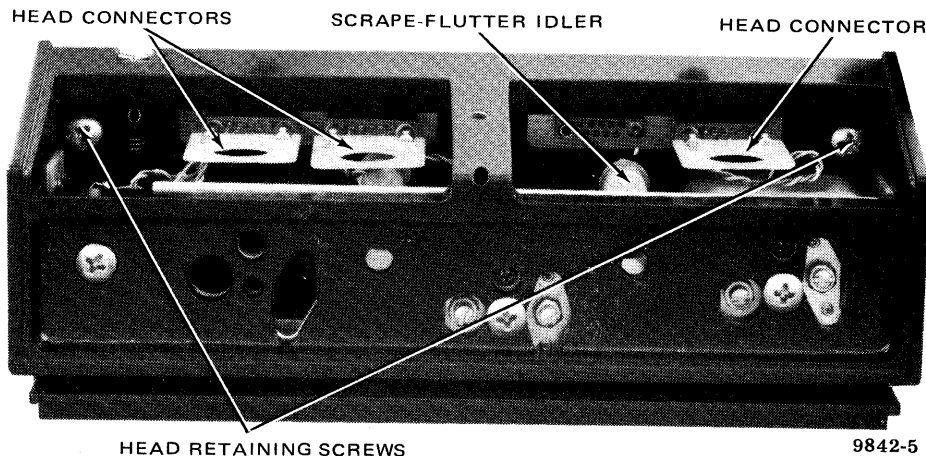

Figure 2-7. Head Assembly (Top View)

3. Remove the two screws holding the head to the top plate.
4. Being careful to avoid bumping or scratching the scrape-flutter idler, lift head assembly up and off.

To install head assembly, proceed as follows:

1. If the head cable box is to be changed, change it before reinstalling the head assembly. (Refer to the following section.)
2. Being careful to avoid bumping or scratching the scrape-flutter idler, mount desired head assembly in place.
3. Install two screws that retain head assembly to top plate.
4. Connect all head connectors.
5. Install stainless steel head cover. Tighten captive screw on slanted rear surface of head assembly.
6. For a four-position head, install switching knob at the center of the head cover.

### Changing Head Cable Box

The head cable box must be changed when adding channels (if the existing box is not adequate) or when adding a two-channel four-track (2-Ch 4-Tr) head. Ampex catalog numbers of various head cable boxes are contained in the Parts Lists section of this manual.

To remove head cable box, proceed as follows:

1. Remove head assembly. (Refer to *Changing Heads* text.)
2. Disconnect all head cables from the rear of the record/reproduce electronics unit(s).
3. Manually support head cable box (Figure 2-4) and remove the screws located behind the head assembly. Then remove the box.

To install head cable box, proceed as follows:

1. Situate head cable box in its mounting position. While manually supporting it, secure box with two retaining screws.
2. Install head assembly. (Refer to *Changing Heads* text.)
3. Connect all head cables to the record/reproduce electronics unit(s).

### SCRAPE-FLUTTER IDLER ADDITION

The optional tape scrape-flutter idler kit (Catalog No. 4010069) contains the idler, a mounting screw, and a lockwasher. The standard-equipment idler with 3/8-inch roller is mounted between head positions 3 and 4 at the factory. The optional idler with 15/32-inch roller mounts between head positions 2 and 3. Install the optional idler as follows:

1. Remove head assembly. (Refer to *Changing Heads* paragraph.)
2. Mount optional idler on locating pin and boss. Then, secure idler with screw and washer.
3. Replace head assembly. (Refer to *Changing Heads* paragraph.)

### CHANNEL ADDITION

The AG-440C Recorder/Reproducer can accommodate up to four record/reproduce channels. To add channels, change the head assembly and head cable box if required. (Refer to *Changing Heads* and *Changing Head Cable Box* paragraphs.) Then, add one record/reproduce unit for each added channel as follows:

#### NOTE

**One interconnecting cable (Catalog No. 4050442) must be connected to each added record/reproduce unit. Optional plug-in input units such as a balanced-line transformer, microphone preamplifier, etc., may be added.**

1. For mounting in portable cases, secure unit(s) in each case with two 12-24 X 3/4 oval-head Phillips screws. Place white nylon cup-washers under the head of each screw.

#### NOTE

Two types of portable cases are available for record/reproduce units. One type is a two-unit case (Catalog No. 4150330) and the other is a four-unit case (Catalog No. 4150331). Two two-unit cases, stacked on top of each other, may be used for four-channel portable systems. For one-channel systems, a blank panel (Catalog No. 4290620) is available to fill the empty space.

2. For mounting in racks or custom consoles, mount the added record/reproduce unit(s) above or below the existing record/reproduce unit(s). (Mounting dimensions are shown in Figure 2-2.) Each additional record/reproduce unit mounted in an Ampex console requires two riser-support castings (Catalog No. 4260404), which are installed as follows:

a. Remove the top cover from over the uppermost installed record/reproduce unit(s). Then remove the unit.

b. Using two 6-32 X 5/8 pan-head screws, two flat washers, two lockwashers, and two 6-32 hex nuts, secure new support castings to the existing supports.

c. Install top cover and unit removed in step a.

d. Mount each added record/reproduce unit between the new support castings and secure with two 12-24 X 3/4 oval-head Phillips screws. Place white nylon cup-washers under the head of each screw.

e. Interconnect the record/reproduce units to the tape transport. (Refer to *Interconnecting Cables* earlier in this section.)

#### NOTE

If the console is equipped with optional rear covers, individual covers (Catalog No. 4040984) should be ordered for each additional record/reproduce unit.

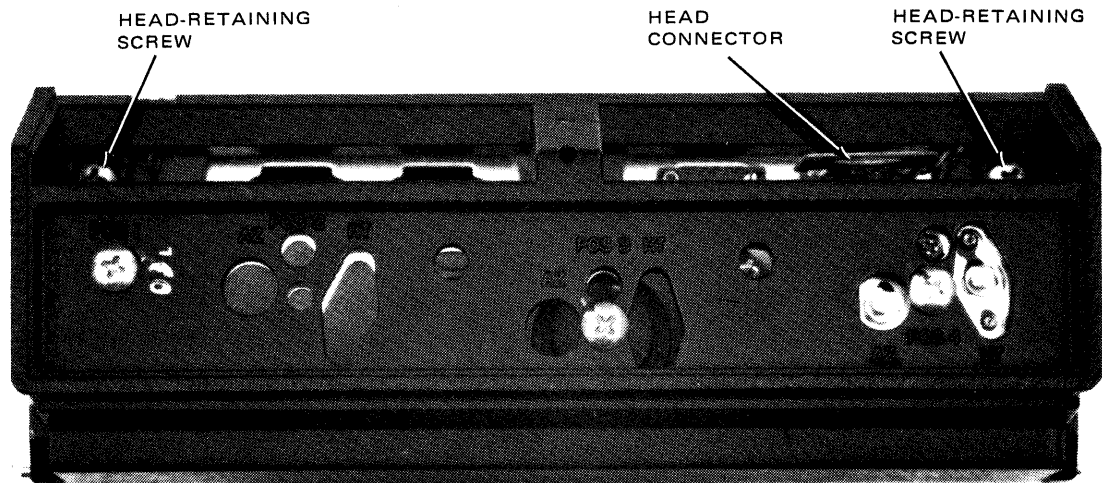

TOP VIEW

13161-7

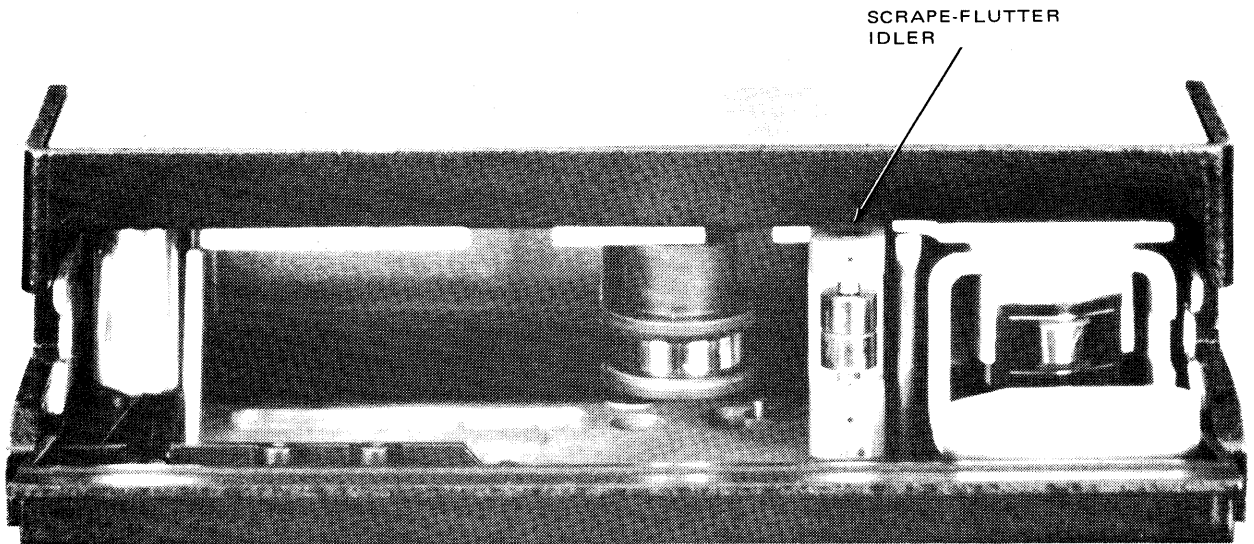

FRONT VIEW

13161-12

**Figure 2-6. Reproduce Head Assembly**

To install the head-cable box, proceed as follows:

1. Situate the head-cable box in its mounting position. While manually supporting the head-cable box, secure the box with the two retaining screws.
2. Install the head assembly.
3. Connect all head cables to the reproduce electronics unit.

### Channel Addition

The reproducer can accommodate up to four reproduce channels. To add channels, change the head assembly and head-cable box if required. (Refer to *Changing Heads* and *Changing Head Cable Box* paragraphs.) Then, add one reproduce unit for each added channel.