

thecarversite.com

This manual is either an original scan from tech's who worked at Carver corp, donated by forum members, or both. These manuals are NOT intended for re-sale. If you purchased a 'Carver Manuals' disc on ebay or another auction site, and it has this material on it, you were ripped off!

Please report any resale of this material to us at thecarversite.com

thecarversite.com

CARVER

M-500 Power Amplifier

SERVICE MANUAL

CONTENTS

	Page
BLOCK DIAGRAM	2
SPECIFICATIONS	2
ALIGNMENT PROCEDURES	3
ALIGNMENT POINTS	3
PCB PS-376 FOIL SIDE VIEW	4
PCB MA-375 FOIL SIDE VIEW	5~6
SCHEMATIC DIAGRAM	7~8
PARTS LIST	9~10

BLOCK DIAGRAM

POWER SUPPLY CONTROL

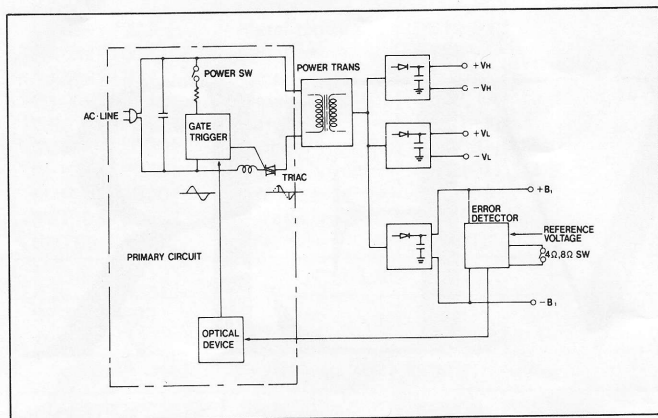

AMPLIFICATION

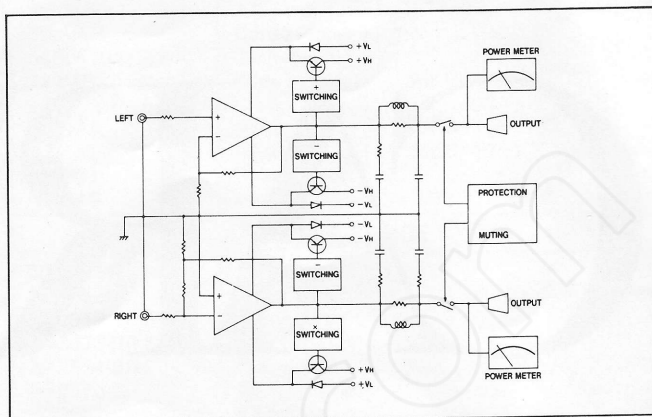

BTL CIRCUIT

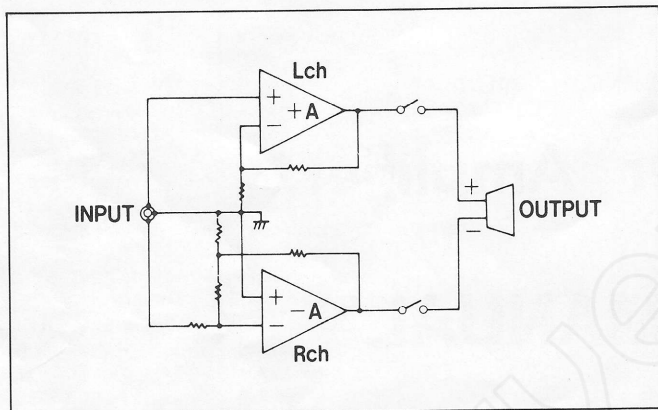

UNIT

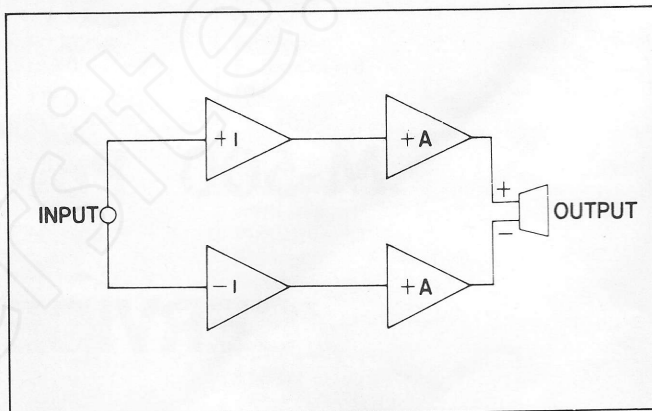

SPECIFICATIONS

- **Sensitivity** 1.4V
Input :1000Hz
Output:200W
- **Output power** more than 200W
Input :Main in
Output:0.05% THD
20Hz-20000Hz continuous both CH. driven
- **IM Distortion factor** less than 0.05%
Input :Aux 60Hz:7000Hz/4.1
Output:200W
- **Frequency response** 20Hz-20000Hz
Input :Main in
Output:1000Hz 20W±0.5dB
- **Signal to noise ratio (IHF-A)** more than 100dB
(Input short) Main in
- **Residual noise(IHF-A)** 200μV
- **Damping factor** more than 30
Input :Aux 150Hz
Output:20W
- **Input impedance** 15 Kohm
at 1000Hz Main in
- **Dynamic head room** stereo 240W(4Ω)
230W(8Ω)
mono 520W(4Ω)
620W(8Ω)
- **Crosstalk**
Between the channels of stereo equipment
Output:20W
Main in (Input:Shorted)
1000Hz more than 80dB
20000Hz more than 60dB
- **Output load**
Speaker output 8ohm
- **Maximum power consumption** 1100watts
- **AC power supply** 220V, 50/60Hz
- **Netweight** 10.5kg
- **Dimension** W=440 H=110 D=348mm

Specifications and design are subject to change without notice.

ALIGNMENT PROCEDURES

Step	Connect	Ajust	Adjust for
POWER SUPPLY			
1	Rotate SVR503 and SVR504 fully counter-clockwise.		
2	<u>VTVM</u> R178 (test point side)	SVR503	74V
5	Set the speaker impedance selector switch to "8Ω".		
BIAS CURRENT			
6	Preheat for more than 5 minutes.		
7	<u>DC digital voltmeter</u> LIVE/GND TP1/TP2 (L) TP3/TP4 (R)	SVR101 (L) SVR102 (R)	6mV±1mV
METER			
8	Confirm that the meters indicate 0 watt at no input.		
9	Input 1kHz to input jacks. Output Speaker out		Speaker out 100W
10		SVR601 (L) SVR602 (R)	Meters 100W

ALIGNMENT POINTS

MA-375 PCB

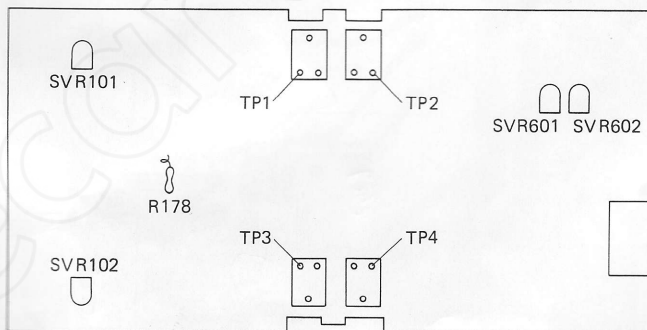

PS-376 PCB

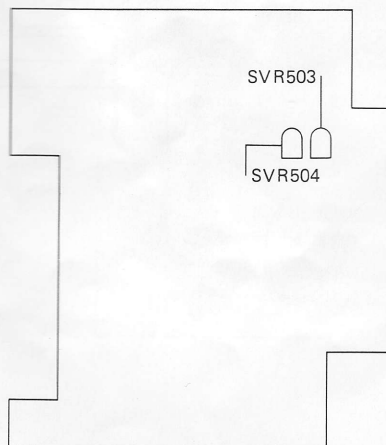

METER UNIT

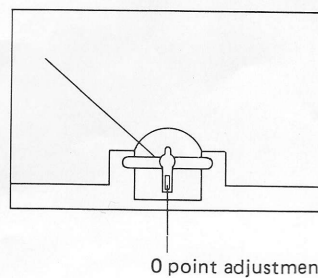

MAIN AMP BOARD (MA-375)

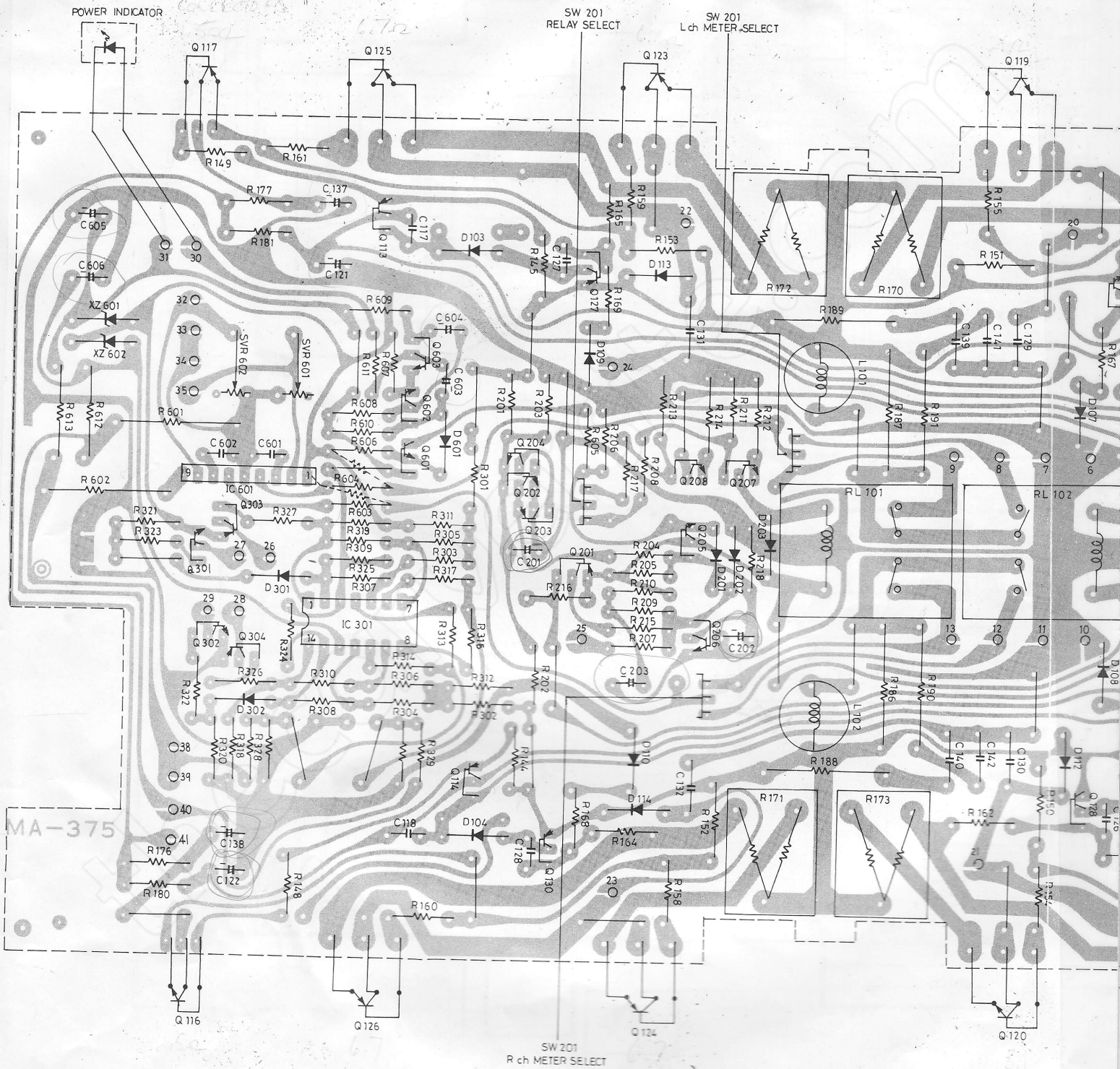

Note: Relay speaker switching and 4Ω → 8Ω rail adjust sw are not available on Model M-500. Front panel on/off sw is also not included on M-500.

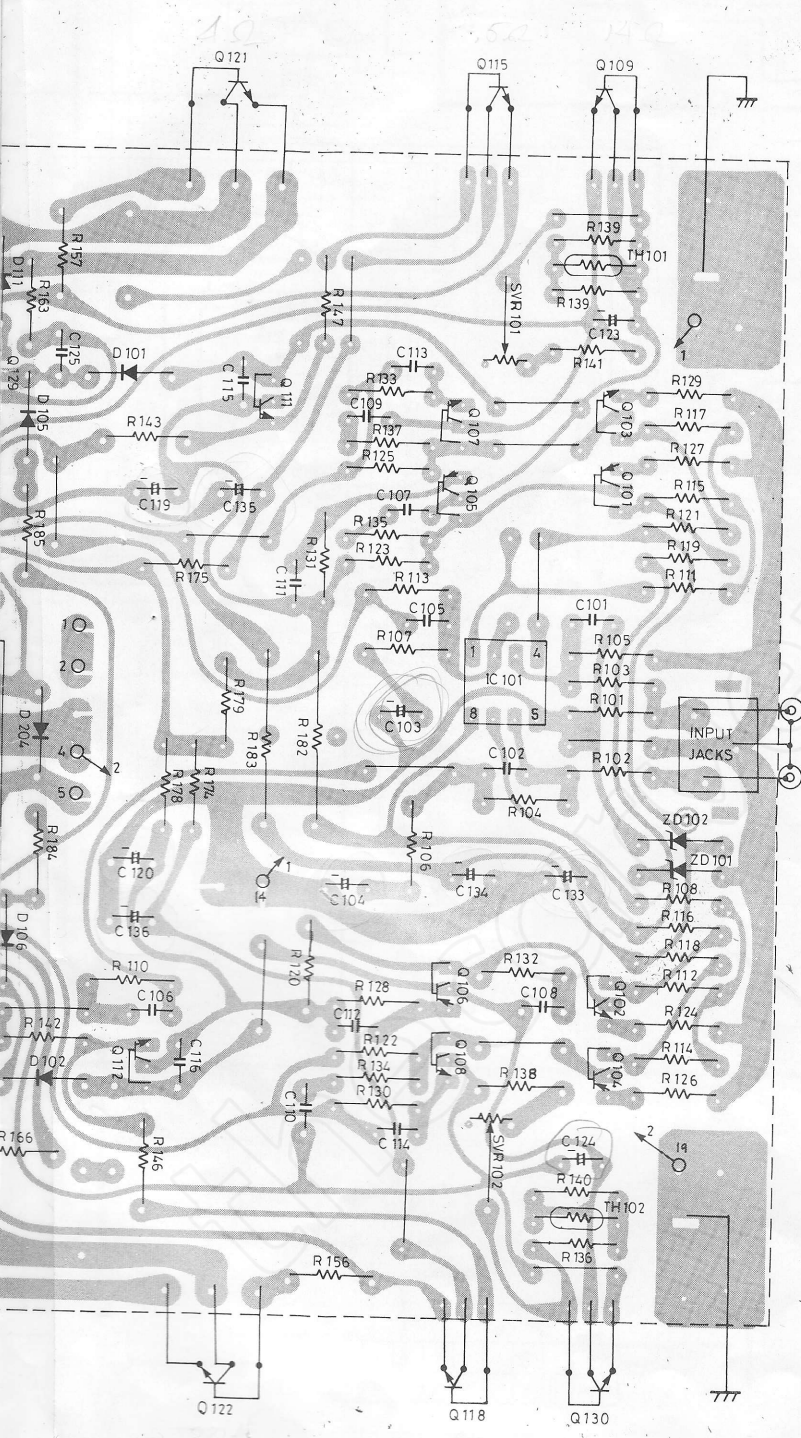

- 1. . . .Thermal relay (to 38)
- 2. . . .Thermal relay (to 5)
- 4. . . .to 19
- 5. . . .Thermal relay (to 2)
- 6. . . .GND
- 7. . . .Speaker A terminal L ch - & R ch +
- 8. . . .Speaker A terminal L ch +
- 9. . . .Speaker B terminal L ch +
- 10. . . .GND
- 11. . . .Speaker B terminal L ch - & R ch +
- 12. . . .Speaker A terminal R ch -
- 13. . . .Speaker B terminal R ch -
- 14. . . .GND (to 17)
- 17. . . .GND (to 14)
- 19. . . .GND (to 4)
- 20. . . .L ch 37.5V/73V
- 21. . . .R ch 37.5V/73V
- 22. . . .L ch -37.5V/-73V
- 23. . . .R ch -37.5V/-73V
- 24. . . .74V
- 25. . . .Muting
- 26. . . .L ch -B Switching
- 27. . . .L ch +B Switching
- 28. . . .R ch -B Switching
- 29. . . .R ch +B Switching
- 32. . . .R ch meter +
- 33. . . .R ch meter -
- 34. . . .L ch meter -
- 35. . . .L ch meter +
- 38. . . .Thermal relay (to 1)
- 39. . . .38V
- 40. . . .-38V
- 41. . . .-74V

SCHEMATIC DIAGRAM

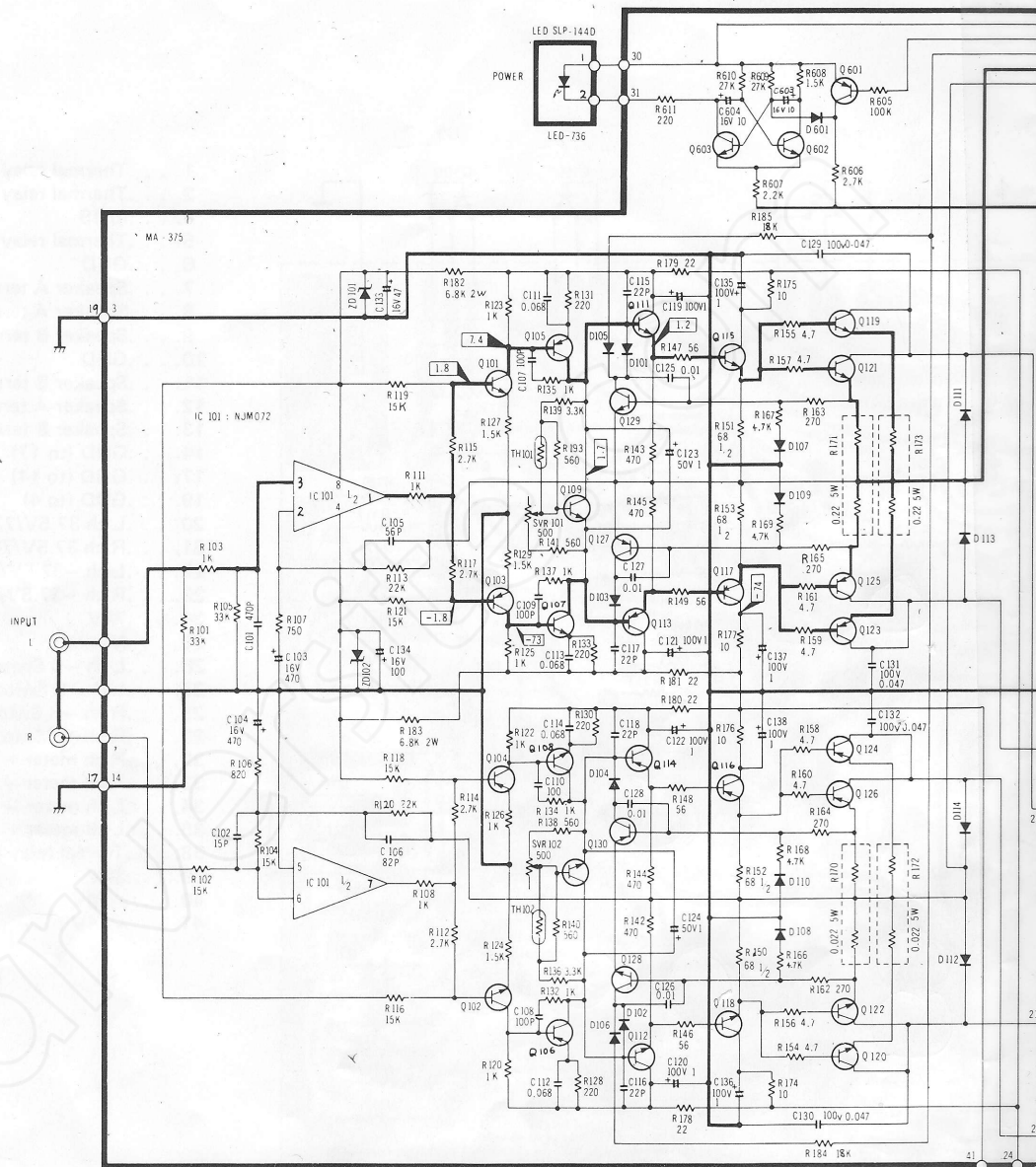

TRANSISTOR

Q 101, 102, 301, 302, 505 : 2SC1980 S.T
 Q 103, 104, 303, 304, 502, 506 : 2SA921 S.T
 Q 105, 106, 113 : 2SA1110 Q.R
 Q 107, 108, 111, 112 : 2SC2550 Q.R
 Q 109, 110 : 2SC1567 Q.R
 Q 115, 118, 403, 404 : 2SC2591 Q.R
 Q 116, 117, 401, 402 : 2SA1111 Q.R
 Q 119, 120, 121, 122 : 2SD745 Q.R
 Q 123~124 : 2SB705 Q.R
 Q 127, 130 : 2SA777 (Q.R)
 Q 128, 129, 207, 208 : 2SC1509 Q.R
 Q 201~223 601 : 2SA722 S.T
 Q 202~206 : 2SC1328 S.T
 Q 405, 406 : 2SD1047 F
 Q 501, 503, 504 : 2SC1688 Q.R
 Q 602, 603 : 2SC536 F,G

ZENER DIODE

ZD 101, 102 : Z147
 ZD 501 : Z2200
 ZD 502 : Z2100
 ZD 503, 504 : Z2765
 ZD 601, 602 : Z2117

DIODE

D 101~110, 507 : 1N4148
 D 111~114, 202~204, 409, 412, 508, 509, 516, 517 : 1N4002
 D 201, 301, 302, 511, 601 : OS 442
 D 401~404 : 30DF 2FC
 D 502~505 : GP30DL
 D 501 : KBPC 25-02
 D 506 : DBA 10C
 D 515 : DBA 10E
 D 518 : DBA 10B

IC 101

IC PIN	1	2	3	4	5	6	7	8
VOLTAGE	0	0	0	-14.7	0	0	0	+14.7

IC 301

IC PIN	1	2	3	4	5	6	7	8	9	10	11	12	13	14
VOLTAGE	0	-11.8	-12	-0.3	4.8	0	-5	0	-5	-0.3	5	12	-11.8	0.5

IC 601

IC PIN	1	2	3	4	5	6	7	8	9
VOLTAGE	0	-8.7	-0.78	0	-8.7	0	-0.79	-8.7	-8.7

() Stands for SEV model

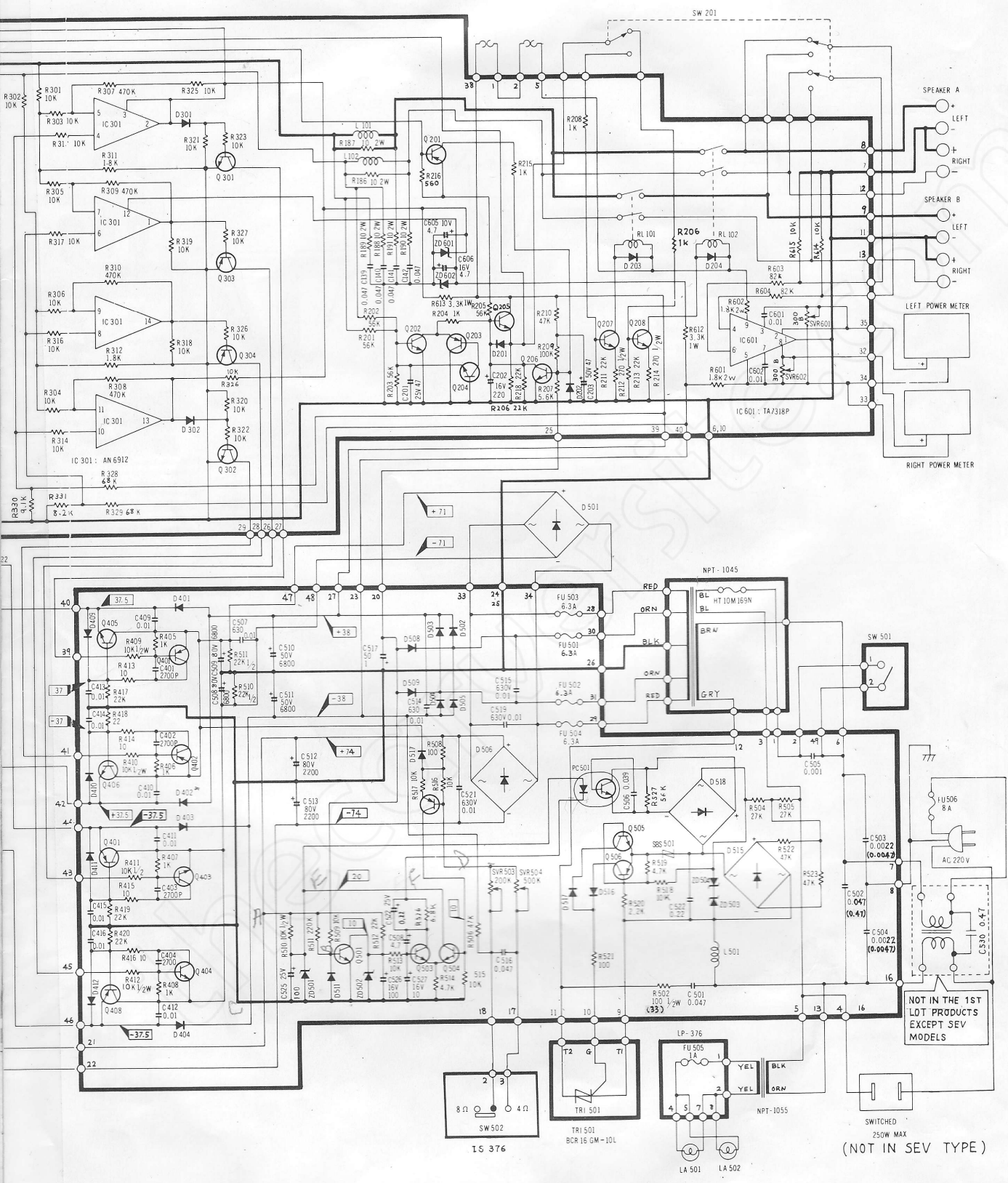

NOT IN THE 1ST LOT PRODUCTS EXCEPT SEV MODELS

SWITCHED 250W MAX (NOT IN SEV TYPE)

PARTS LIST

Parts No.	Description	Symbol No.	Q'ty
SEMICONDUCTORS			
AN6912	IC	IC301	1
TA7318P	IC	IC601	1
TL072 or NJM072	IC	IC101	1
2SA921 (S or T)	Transistor	Q103, 104, 303, 304, 502, 506	6
2SC1685 (Q or R)	Transistor	Q501, 503, 504	3
2SC1980 (S or T)	Transistor	Q101, 102, 301, 302, 505	5
2SA1111 (Q or R)	Transistor	Q116, 117, 401, 402	4
2SB817 (E)	Transistor	Q407, 408	2
2SC2591 (Q or R)	Transistor	Q115, 118, 403, 404	2
2SD1047 (E)	Transistor	Q405, 406	2
2SA722 (S or T)	Transistor	Q201, 203, 601	3
2SC1328 (S or T)	Transistor	Q202, 204 ~ 206	4
2SC1509 (Q or R)	Transistor	Q128, 129, 207, 208	4
2SC536 (F or G)	Transistor	Q602, 603	2
2SA777 (Q or R)	Transistor	Q127, 130	2
2SA1110 (Q or R)	Transistor	Q105, 106, 113, 114	4
2SB705 (Q or R)	Transistor	Q123 ~ 126	4
2SC2590 (Q or R)	Transistor	Q107, 108, 111, 112	4
2SD745 (Q or R)	Transistor	Q119 ~ 122	4
2SC1567 (Q or R)	Transistor	Q109, 110	2
DBA10B	Rectifier bridge	D518	1
DBA10C	Rectifier bridge	D506	1
DBA10E	Rectifier bridge	D515	1
KBPC25-02	Rectifier bridge	D502	1
1N4002	Diode	D111 ~ 114, 202 ~ 204, 409 ~ 412, 507 ~ 509, 516, 517	16
GP30D-L	Diode	D502 ~ 505	4
DS442	Diode	D201, 301, 302, 511, 601	5
1N4148	Diode	D101 ~ 110	10
30DF2FC or RGP30G-5001L	Diode	D401 ~ 404	4
XZ-100	Zener diode	ZD502	1
XZ-200	Zener diode	ZD501	1
XZ-265	Zener diode	ZD503, 504	2
XZ-117	Zener diode	ZD601, 602	2
XZ-147	Zener diode	ZD101, 102	2
SLP-144D	LED	Power indicator	1
SM16JZ41	Triac	TRI501	1
BS08A	SBS	SBS501	1
PC-713	Photo coupler	PC501	1
CAPACITORS			
NP-25TW470M	Electrolytic (non-pole)	C201	1
MS-16TW100M	Electrolytic	C527, 603, 604	3
MS-16TW470M	Electrolytic	C133, 605, 606	3
MS-16TW101M	Electrolytic	C134, 526	2
MS-16TW221M	Electrolytic	C202	1
MS-16TW471M	Electrolytic	C103, 104	2
MS-25TW1ROM	Electrolytic	C522	1
MS-25TW4R7M	Electrolytic	C528	1
MS-25TW101M	Electrolytic	C525	1
MS-50TW1ROM	Electrolytic	C123, 124, 517	3
MS-50TW470M	Electrolytic	C203	1
MS100TW1ROM	Electrolytic	C119 ~ 122, 135 ~ 138	8
LHL1H682QHS	Electrolytic	C510, 511	2
LUB1K222MHS	Electrolytic	C512, 513	2
LHH1K682THH	Electrolytic	C508, 509	2
HE12SJYB103K	Ceramic	C409 ~ 412	4
HE40SJSL150K	Ceramic	C102	1
HE40SJSL560K	Ceramic	C105	1
HE50SJSL820K	Ceramic	C106	1
HE50SJSL101K	Ceramic	C107 ~ 110	4
HE50SJYB102K	Ceramic	C413 ~ 416	4
HM60SJSL220K	Ceramic	C115 ~ 118	4
HE70SJYB272K	Ceramic	C401 ~ 404	4
HE90SJSL471K	Ceramic	C101	1

Parts No.	Description	Symbol No.	Q'ty
MY-50VS103J	Mylar	C125 ~ 128, 601, 602	6
MY-50VS393J	Mylar	C506	1
MY-50VS683J	Mylar	C111 ~ 114	4
PME271Y447	Polyester (SEV)	C503, 504	2
ECQ-U2A222MF	Polyester	C503, 504	2
ECQ-U2A102MF	Polyester	C505	1
ECQ-E2A473MM	Polyester	C501, 502	2
PME271M647	Polyester (SEV)	C502	1
MF-630TD103-M or TDXM-2J103KZBT	Polyester	C507, 514, 515, 519, 521	5
MF-250TD473-M or TDXM-2E473KZBT	Polyester	C516	1
MF-250TD224-M	Polyester	C529	1
ECQ-M1473MZ	Polyester	C129 ~ 132, 139 ~ 142	8
RESISTORS			
KA25SS101J	Carbon	R521	1
KA25SS222J	Carbon	R520	1
KA25SS472J	Carbon	R514, 519	2
KA25SS103J	Carbon	R513, 515 ~ 518	5
KA25SS223J	Carbon	R512	1
KA25SS224J	Carbon	R511	1
KA25ST4R7J	Carbon	R154 ~ 161	8
KA25ST100J	Carbon	R174 ~ 177, 413 ~ 416	8
KA25ST220J	Carbon	R178 ~ 181	4
KA25ST560J	Carbon	R146 ~ 149	4
KA25ST101J	Carbon	R508	1
KA25ST221J	Carbon	R128, 130, 131, 133, 611	5
KA25ST271J	Carbon	R162 ~ 165	4
KA25ST471J	Carbon	R142 ~ 145	4
KA25ST561J	Carbon	R138, 140, 141, 193, 216	5
KA25ST751J	Carbon	R107	1
KA25ST821J	Carbon	R106	1
KA25ST102J	Carbon	R103, 108, 111, 120, 122, 123, 125, 132, 134, 135, 137, 204, 208, 215, 217, 405 ~ 408, 608	20
KA25ST152J	Carbon	R124, 126, 127, 129, 607	5
KA25ST182J	Carbon	R311, 312	2
KA25ST272J	Carbon	R122, 114, 115, 117	4
KA25ST332J	Carbon	R136, 139, 606	3
KA25ST472J	Carbon	R166 ~ 169	4
KA25ST562J	Carbon	R207	1
KA25ST682J	Carbon	R526	1
KA25ST822J	Carbon	R331	1
KA25ST912J	Carbon	R330	1
KA25ST103J	Carbon	R301 ~ 306, 313, 314, 316 ~ 327, 509, 614, 615	23
KA25ST153J	Carbon	R102, 104, 116, 118, 119, 121	6
KA25ST183J	Carbon	R184, 185	2
KA25ST223J	Carbon	R110, 113, 206, 211, 213, 218, 417 ~ 420	10
KA25ST273J	Carbon	R609, 610	2
KA25ST333J	Carbon	R101, 105	2
KA25ST473J	Carbon	R210, 506, 522, 523	4
KA25ST563J	Carbon	R201 ~ 203, 205, 527	5
KA25ST683J	Carbon	R328, 329	2
KA25ST823J	Carbon	R603, 604	2
KA25ST104J	Carbon	R209, 605	2
KA25ST474J	Carbon	R307 ~ 310	4
KA50ST330J	Carbon (SEV)	R502	1
KA50ST680J	Carbon	R150 ~ 153	4
KA50ST101J	Carbon	R502	1
KA50ST271J	Carbon	R212, 214	2
KA50ST103J	Carbon	R409 ~ 412, 510	5
KA50ST223J	Carbon	R524, 525	2

PARTS LIST

Parts No.	Description	Symbol No.	Q'ty
KA50ST273J	Carbon	R504, 505	2
SA-1WT332J	Metal oxide	R612,613	2
SA-2WT100J	Metal oxide	R186~191	6
SA-2WT182J	Metal oxide	R601,602	2
SA-2WT682J	Metal oxide	R182,183	2
ERF-5GEKR22N	Network	R170~173	4
SVR-08T3B301	Carbon trimmer	SVR601,602	2
SVR-08T3B501	Carbon trimmer	SVR101,102	2
SVR-08T3B204	Carbon trimmer	SVR503	1
SVR-08T3B504	Carbon trimmer	SVR504	1
SDT65	Thermistor	TH101,102	2
COILS			
SF-HP-6A-03		L501	1
104001		L101,102	2
FUSES & HOLDERS			
FU-521027T	Fuse	FU505	1
FU-526327T	Fuse	FU501~504	4
FU-528025T	Fuse	FU506	1
or FU-528027T			
FUH-002	Fuse holder		10
FH-033	Fuse holder		1
180008	Relay	RL101,102	2
BF352-53001A	Lamp	LA501	1
BF352-53002A	Lamp	LA502	1
SW-1101072	Power switch	SW501	1
SW-2426081	Speaker selector switch	SW201	1
SS22B-P1907	Impedance selector switch	SW502	1
KL-290D-2	Meter		2
UI2-10005-200A	Thermal relay	RL101,102	2
NPT-1045	Power transformer		1
NPT-1055	Power transformer		1
IB3600	Case		2
ANB-020-AAA	Speaker terminal		1
AJC-056-AAB	RCA jacks		1
S2-729T-100	AC outlet		1
UB-0029-1	GND terminal		1

Parts No.	Description	Symbol No.	Q'ty
ACC-024	AC cord		1
SR-5N-4	Cord stopper		1
59BS4795	Terminal lug		2
1S3MB	Mica	for Q401,405,406,408	4
No.18A	Mica	for Q115~118	4
S-27	Mica	for Q119~126	8
RP-003	Wrapping pin		12
No.24B	Bushing		4
APPEARANCE			
N20821A	Front panel		1
N30552	Meter panel		1
N42650A	Front glass		1
N42573-BR1	Side cap R		1
N42574-BR1	Side cap L		1
N42570-G	Window trim		2
N42647	Trim base		2
N42681	Knob (speaker selector)		1
N42571A	Knob (power)		1
N42572	Knob guide		1
N20824-BR	Cabinet		1
N20823A	Rear panel		1
N30551A	Bottom board		1
T-C	Foot		4
N20822	Front chassis		1
N30553	Center chassis		1
N30554	Power transformer chassis		1
N30555	Joint angle		2
N30556	Fittings for lamp		1
N42388	Fittings for thermal relay		2
N30557	Side heatsink		1
N30582A	Heatsink		2
N30558	Shower glass		1
N42666	Rubber cushion		2
N41960	Cabinet mat		1
N42667	Meter cushion		4
N42669	Lamp shield paper		1
N42710	Meter cushion		2
N42711	Rubber cushion		1
N42789	Rubber spacer		1
N42792	Rubber cushion		1
N42947	Stad		1

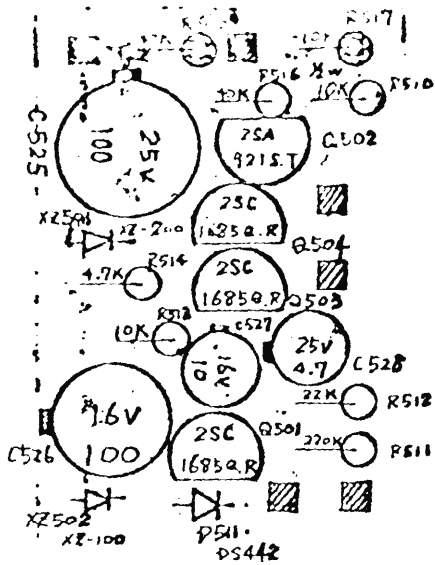

GC-377
Serial Voltage
Regulator

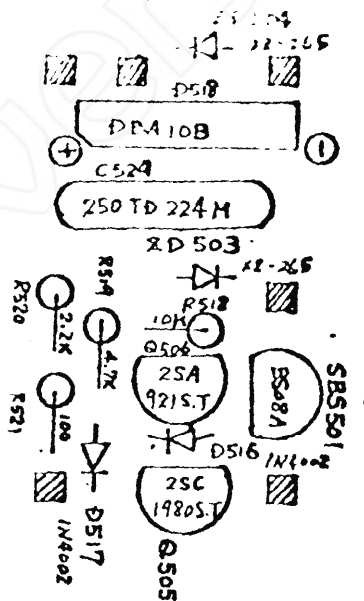

GT-377
Serial Phase
Network

M-500

SUB ASSEMBLY PARTS LOCATION

CARVER CORPORATION

SERVICE BULLETIN

Service Bulletin # M-500-2

Model: M-500

Serial nos. As Needed

REASON:

Date: 2/04/91

To avoid replacing entire GT-377 (Phase Network) Sub Board.

DELETE

Qty 1 BS08A (SBS501)
P/N BS08A

Qty 1 56k 1/4W resistor (R527)
P/N KA25ST563J

ADD

Qty 1 MBS4991 (SBS501)
P/N BS08A

Qty 1 39k 1/4W resistor (R527)
P/N 251-00108-00

PROCEDURE

If the amplifier fails to turn on reliably, or not at all, it may be due to a failure of the Silicon Bidirectional Switch (Diode Thyristor) SBS501 (BS08A), located on the GT-377 Sub Board.

- 1) First try normal troubleshooting techniques to determine if there is a faulty component elsewhere in the amplifier, which is activating the protection circuitry (i.e. shorted output transistors, shorted pre-drivers, shorted bridge rectifier, etc.).

This may be facilitated by shorting across pins T1 and T2 of the triac TRI501. CAUTION: When bypassing the triac, a Variac must be used to apply a line voltage of no more than 50VAC, because the Magnetic Field Coil cannot accept 120VAC without triac control.

- 2) If no shorts are found, try turning SVR503 (located on the power supply board) clockwise a bit. SVR503 adjusts the high rail voltage, and the amplifier will not turn on if the rail voltage is set too low.
- 3) If the amplifier still does not turn on, set SVR503 back to its original position and try replacing R527 (56k 1/4W resistor) with a 39k 1/4W resistor (see Figure 1 next page).
- 4) If the amplifier still fails to turn on, try replacing SBS501. Since the BS08A part is no longer available from Carver, substitute a Motorola MBS4991 in its place. Note that when a MBS4991 is used, R527 should be changed to a 39k 1/4W resistor.
- 5) The amplifier should start with a minimum of 90VAC line voltage. R527 may be decreased in value if necessary until the power supply triggers at 90VAC.

NOTE: When removing and re-installing the GT-377 Sub Board, do not overheat the connecting pins as this can cause the solder connections on the Sub Board to become intermittent.

Engineering approval

John P. Johnson 3-5-91

Service approval

B. Cooper

CARVER CORPORATION SERVICE BULLETIN

Service Bulletin # M-500-2

Model: M-500

Serial nos. See Page 1

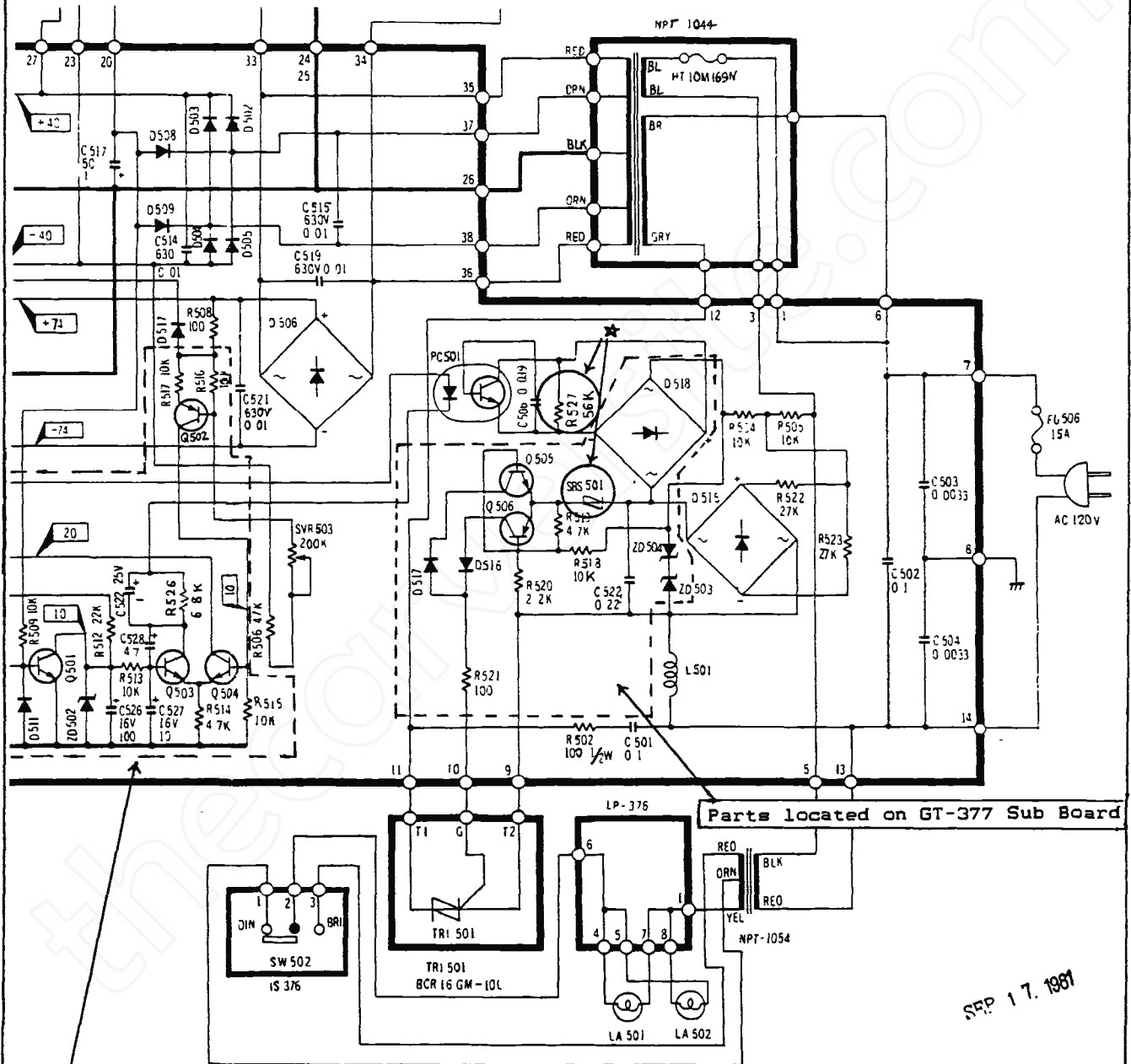

**CARVER Corporation
M-500**

Figure 1