

Changes from:  
 Assembly 80-00600 Rev (B):  
 1. R107, R207 TO 470K.  
 2. PCB AND 80-00100 UNCHANGED.

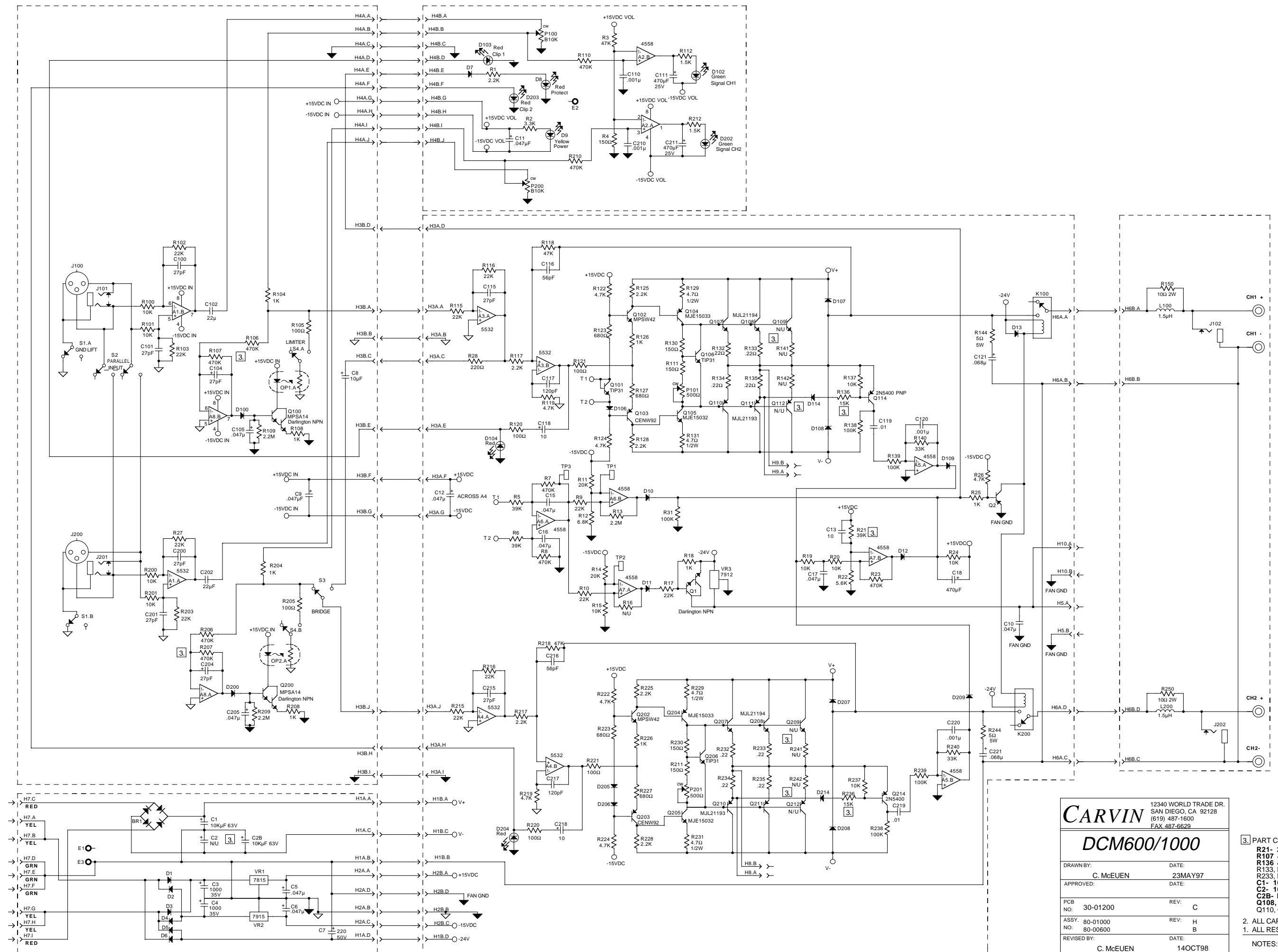

**CARVIN** 12340 WORLD TRADE DR.  
 SAN DIEGO, CA 92128  
 (619) 487-1600  
 FAX 487-6629

**DCM600/1000**

DRAWN BY:	C. McEUEEN	DATE:	23MAY97
APPROVED:		DATE:	
PCB NO:	30-01200	REV:	C
ASSY. NO:	80-01000	REV:	H
REVISED BY:	C. McEUEEN	DATE:	14OCT98

3. PART CHANGES FOR DCM1000 ASSEMBLY: 80-01000
- R21- 27K
  - R107 & R207 - 470K
  - R136 & R236 - 15K
  - R133, R134, R141, R142 - 22Ω 5W
  - R233, R234, R241, R242 - 22Ω 5W
  - C1- 10,000mF 80V
  - C2B- Not Used
  - Q108, Q109, Q208, Q209 - MJL21194 NPN
  - Q110, Q112, Q210, Q212 - MJL21193 PNP
2. ALL CAPACITORS IN MICORFARADS, EXCEPT AS NOTED.  
 1. ALL RESISTORS IN OHMS
- NOTES: UNLESS OTHERWISE SPECIFIED.